

PARTS CATALOG
and
INSTRUCTIONS
for
Installation, Operation and Maintenance
of
MARVEL NO. 2 DRAW-CUT HACK SAW

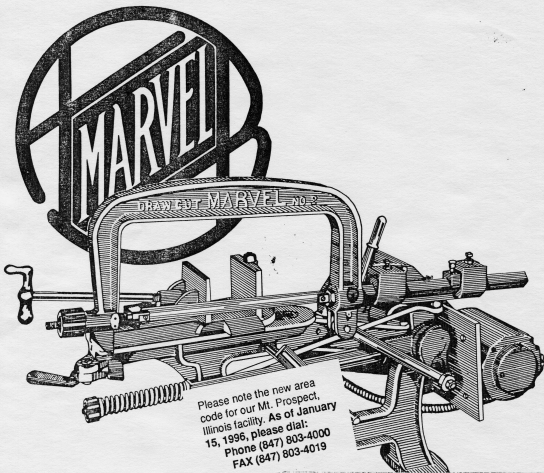

Please note the new area
code for our Mt. Prospect,
Illinois facility. As of January
15, 1996, please dial:
Phone (847) 803-4000
FAX (847) 803-4019



ARMSTRONG-BLUM MFG. CO.

marvel

ARMSTRONG-BLUM MFG. CO.

1441 Business Center Drive • Mount Prospect, IL 60056

Telephone: 1 708 803-4000

FAX: 1 708 803-4019

1-800 4-SAWING (1-800 472-9464) • In Illinois 1-800 4-MARVEL (1-800 462 7835)

EXPLANATION

This parts list is made up of "Exploded Assembly" sheets covering the Belt Driven Machine and the Motor Driven Machine. Each sheet shows only those parts in their relative assembly location, which are functionally related to each other. Any part that we can furnish as an individual or single piece is identified in the isometric drawings by its individual part number and is also listed in the parts list column with its "Description" or part name.

Any part which, due to our manufacturing processes, we permanently attach to other parts by welding, pressing, riveting, or which we finish in matched pairs or sets can be furnished only as an assembly. In such cases only the complete assembly number is shown, which with its listed descriptive name, fully identifies such "inseparable" parts assembly.

Standard stock fasteners (screws, bolts, etc.) are not assigned part numbers, but are identified by quantity, size and abbreviated symbol of type or style. Example: top left corner of page 5 shows (8) - 1/4 x 5/8 RHMS. That means that a total of eight - 1/4" x 5/8" long Round Head Machine Screws are required to attach the gear case cover to the gear case. See list below for symbols of other fasteners. All screws are U.S. Standard (coarse thread) and all set screws are cup point, unless otherwise specified. Special fasteners, such as screws that are not available from local hardware stocks, are assigned a part number because they are available only from us; and the part number is preceded in the drawing by the quantity required, in parentheses.

ABBREVIATED SYMBOLS FOR STANDARD FASTENERS

<u>SYMBOL</u>	<u>TYPE OF FASTENER</u>	<u>SYMBOL</u>	<u>TYPE OF FASTENER</u>
CB	Carriage Bolt	PHCS	Phillister Head Cap Screw
FHCS	Flat Head Cap Screw	PHMS	Phillister Head Machine Screw
FHMS	Flat Head Machine Screw	RHMS	Round Head Machine Screw
FWW	Flat Wrought Washer	SHCS	Socket Head Cap Screw
HHCS	Hex Head Cap Screw	SHSS	Slotted Head Set Screw
HHMS	Hex Head Machine Screw	SQSS	Square Head Set Screw
HHSS	Socket Head Set Screw	TS	Thumb Screw
HJN	Hex Jam Nut	SN	Square Nut
HN	Hex Nut	CHN	Castellated Hex Nut
MB	Machine Bolt	LW	Lock Washer
OHMS	Oval Head Machine Screw	PFHMS	Phillips Flat Head Machine Screw

WHEN ORDERING PARTS ALWAYS SPECIFY,

1 - Quantity required

2 - Part Number

3 - Part Name or Description

INSTRUCTION REFERENCE

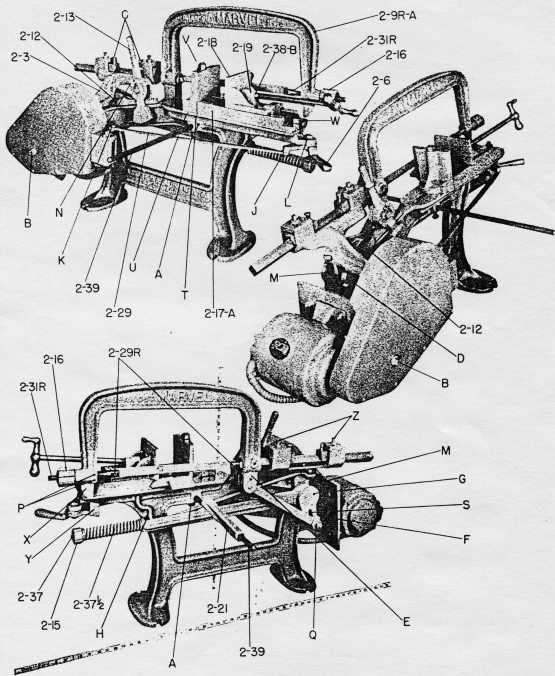

INSTRUCTIONS

FOREWARD

The No. 2 MARVEL Hack Saw is so extremely simple, with the fewest possible number of moving parts, it should be so easily understood that instructions for operation are rarely necessary. However, the following detailed instructions are for the novice who has had little or no experience with even the simplest of machine tools.

INITIAL ASSEMBLY

The machine is always shipped from the factory, whether belt-driven or individually motor-driven, completely assembled and ready for use, with the single exception that for convenience in shipping, the length-gauge rod 2-39 and its gauge-casting 2-21 are removed from the machine and secured to the side of the bed frame. Simply insert gauge rod 2-39 thru hole in bed frame, and secure with thumb-screw "A". This gauge assembly is simply a convenient accessory for duplicating cut-off length whenever you want to consecutively cut off a number of pieces of material to the same length. After setting your work bar for the first cut by measuring from end of work to blade, simply set gauge casting 2-21 in contact with the end of your work. Duplicate length cuts are then repeated by simply pushing your work bar thru the vise to contact the gauge casting. When not in use, simply turn the gauge casting down out of the way.

INITIAL CLEANING

Before connecting the motor leads to your line current, clean the machine thoroughly with a solvent such as kerosene, to remove all anti-rust coatings and such dirt and grit as may have collected during shipment and storage. Then lubricate thoroughly, under the following instructions.

INITIAL LUBRICATION

Before starting the motor, in initial installation:

1. Remove pipe plug "B" from transmission case. This case has been filled with oil to proper operating level at the factory before shipment, but some oil may have leaked out, especially if the machine had been tipped or laid on its side during shipment. Add lubricating oil as necessary to bring oil level to the point where it begins to overflow out the pipe-plugged hole in the case cover, and replace the pipe plug. Use a good grade of medium-body lubricating oil, preferably SAE #30 both in this transmission case and for ALL OTHER LUBRICATION of this machine. If climatic conditions demand corrosion-inhibited lubrication, Fed. Spec. P-10 Grade II, or U.S.A. 2-126 Preservative Engine Oil is recommended.

2. Using the same type of oil as above:

- a. Fill oil cups "C" which are partially filled with wool or felt wicking to retard oil flow.

- b. Fill oil trough "D" that oils the main crankshaft bearings.
- c. Fill oil holes "E", "F", and "G" to over-flowing.
- d. Flood the exposed periphery of cam at "M" with oil.
- e. Put a few drops of oil on the spring rod at "H" on both sides of the guide hole.
- f. Flood feed spring 2-37-1/2 liberally, so that some oil will drip thru the spring onto the threads of the spring rod.
- g. Coat the upper surface of feed wedge 2-12 liberally.
- h. Withdraw chuck screw 2-38-B and liberally coat its threads.
- j. Remove saw blade and liberally coat the entire length of thread of the front blade holder 2-31R.
- k. Put a few drops of oil on the joints of starting rod 2-29 and starting handle 2-6 at "J", "K", and "L".

3. Examine the motor. If it is a sleeve-bearing motor, it will be provided with oil cups which must be filled with oil, preferably a light oil SAE #10 or equivalent. If it is not provided with oil cups, it is a ball bearing motor which has been "permanently" lubricated and should not require re-packing with grease for several years in normal operation.

CRANK-SHAFT ROTATION

An arrow on the face of the crank shows correct direction of rotation which is clockwise when viewed from the crank end of the crank-shaft. Motors are geared direct to crank-shaft and must rotate clockwise when viewed from the shaft end of motor.

INITIAL STARTING

Start the machine running, by starting the motor. During the first few minutes that machine is run initially, and while running, repeat above lubrication operations 2a, 2b, 2c, and 2d. (To re-fill oil hole "G", it is necessary to momentarily stop the machine.) Such extra-liberal lubrication during the first or initial running of this machine will assure long, trouble-free life.

DAILY LUBRICATION

Once each day, or before starting the machine after any idle period of 24 hours or more, lubricate all important moving parts by following above initial lubrication instructions 2a, 2b, 2c, and 2d.

Always use medium-heavy lubricating oil SAE #30 or equivalent for all lubricating purposes. (If climatic conditions demand corrosion-inhibited lubrication, Fed. Spec. P-10 Grade II, or U.S.A. 2-126 Preservative Engine Oil is recommended.)

PERIODIC LUBRICATION

At least once each six months, repeat all the above "initial lubrication" instructions.

OPERATING INSTRUCTIONS

To raise blade frame 2-9R-A to open or starting position, simply lift the blade frame with your right hand. Simultaneously, with your left hand, move feed handle 2-13 forward to drive feed wedge 2-12 under bracket 2-3 to thus keep the saw frame from falling. Saw tightener nut 2-16 provides a convenient grip for lifting the blade frame.

To open vise or chuck, unscrew chuck screw 2-38-B until end of screw no longer projects thru ratchet nut 2-19. Raise the ball handle end of chuck screw and pull towards you, thus lifting ratchet nut out of the ratchet and thus drawing the moveable chuck jaw 2-18 forward.

To clamp or "chuck" your work. First, unscrew chuck screw sufficiently so that its end does not extend thru the ratchet nut. Set work against rear or fixed jaw of the vise. While lifting slightly on the ball handle of chuck screw (to raise the nut free of the ratchet), push entire moveable jaw assembly forward into contact with the work by pushing ONLY on the ball handle. While thus holding the moveable jaw against the work, lower vise screw (to engage the nut with that tooth of the ratchet that is as close-as-possible to the work), using both hands on the ball handle to securely clamp your work. CAUTION: If you had not unscrewed the vise to withdraw its end within the nut before pushing the jaw assembly into contact with your work, you may not be able to drop the nut into a ratchet tooth sufficiently far enough forward to allow enough forward movement of the jaw to actually clamp the work; in which case, the jaw itself may merely become locked between the "heel" of the nut and the end of the vise screw when you tighten the screw. Therefore, until you become familiar with the "feel" of the vise, it is best to always grasp the work and try to lift it, to be sure it is actually clamped before you start sawing.

To start a saw cut. After having clamped your work securely in the vise, throw starting handle 2-6 to the left, which closes the switch and starts the motor and machine running. (On belt driven machine, this handle engages the drive clutch with the pulley.) Before starting, lower blade frame to the point where the blade is just clear of the top of the material to be cut. With feed wedge 2-12 left in, to support the blade frame, saw will feed down slowly to sensitively start the cut and thus prevent ripping out of saw teeth. After the blade has cut about 1/4" into the work, feed wedge can be withdrawn entirely by moving feed handle 2-13 to the rear, to thus allow feed spring 2-37-1/2 to apply its full feed pressure to the blade.

Automatic stop. When saw cut is complete, lug "X" of blade frame will strike finger "Y" of starting handle to thus open the switch and stop the motor and the machine (or will open clutch of belt driven machine).

Feed Adjustment. Normal feed pressure, for average or universal work, is obtained when the threaded end of tension rod 2-37 extends about 1/4" to 3/8" beyond the outer rim of spring rod nut 2-15. One or two turns of the spring rod nut will increase or decrease feed pressure to efficiently adjust pressure for heavy and light work, respectively, when adjustment proves necessary or desirable. For sawing extremely light work such as pipe, angle iron, and small bars, feed wedge 2-12 should be left in to support bracket 2-3 during the sawing operation to reduce

the feed-pressure-effectiveness of feed spring 2-37-1/2; and a slight adjustment of thumb screw "N" in feed handle 2-13 will further vary the feed pressure on the blade. Turning this thumb screw to the right reduces feed pressure by applying friction to the feed wedge to thus retard its working out from under the bracket during sawing; and turning this thumb screw to the left reduces friction and hence increases feed pressure.

To remove the blade always first relieve tension by backing-off Saw Tightener Nut 2-16 before backing-out Blade Holder Screw-Pins 2-29R. Back-out Screw-pins 2-29R only far enough to drop the blade; it is best not to remove them entirely, as they may be dropped and lost.

To insert a blade. Since machine cuts on the "pull" or "draw-stroke", teeth of blade must point to the rear (toward the crank-shaft); blade will not cut if put in backwards. Always be sure Blade Holder Screw-pins 2-29R are first tightened securely to clamp the blade in both holders before tensioning. Then tension the blade by turning Saw Tightener Nut 2-16 with about all the strain the average man can apply with only his right hand (no tools) on the Saw Tightener Nut 2-16.

Adjustment for Blade Alignment. The two 1/4" set screws "P" can be used to rotate the front blade holder slightly to correct blade alignment. If a blade has a tendency to saw "off square", loosen one set screw and tighten the other, to thus slightly twist the blade in the opposite direction from which it showed a tendency to cut off-square. But always leave both set screws tight.

Blade Size or Dimensions. The No. 2 MARVEL Hack Saw Machine can use any length of blade from 12" to 18" of U.S. and European standard catalog lengths. Of course, horizontal capacity of the machine varies in proportion to length of blade. To be sure that the blade in the machine is long enough for the particular size of work to be cut, always watch a few strokes of the machine before the blade starts cutting, to be sure that the front blade holder will not strike the work during any portion of the cutting cycle, from top-to-bottom of the work. If the front blade holder will not clear the work, put in a longer blade, and refer to the following instruction, "Adjustable Stroke". Because of the danger of machine damage that can be caused by attempting to saw work too large for the length of blade, it is strongly recommended that a maximum-length blade be used at all times, on all sizes of work; and that blades of only 14 teeth per inch be used for general or "universal" work. We therefore recommend high speed steel blades 17" x 1" x .050" (or .049") x 14 teeth per inch for this machine. For best results, insist upon genuine MARVEL High-Speed-Edge Hack Saw Blades, MARVEL Stock Number 1714-L. If European blades are your only source of supply and you cannot procure 17", use European Standard 18" x 1" x .050" (or .049") x 14 teeth per inch.

Adjustable Stroke. The No. 2 MARVEL Hack Saw has a slotted crank "S" for convenient change of stroke length. All machines are shipped from the factory with crank-pin-bolt at outer end of slotted crank for longest stroke of approximately 6-3/4"; and with Vise Body 2-17-A set at position "T" so that rear blade holder will not strike it when running on longest stroke. When thus set at longest stroke, and when using a 17" or 18" blade, the No. 2 machine has a capacity to cut thru work not more than 6-5/8" round or 6-1/4" square.

To increase capacity to maximum 8" x 8". Shorten stroke by shifting crank-pin-bolt to bottom of slotted crank "S"; and shift vise body to rear to set at match-line "U". When thus shifting the vise position, be sure rear or fixed jaw is square with the blade before tightening machine-bolt "V". (When cutting more than 6-5/8" capacity do not use machine bolt "W".) Match-line "T" and "U" are 1-1/2" apart.

Swivel the vise to cut at an angle. For angular sawing (other than square or 90 degrees), remove front machine-bolt "W" entirely. Loosen rear machine-bolt "V" and swing the entire vise assembly on the rear bolt to the desired angle, using a protractor on rear vise jaw and blade to set at desired angle. With a wrench on nut of crank-pin-bolt "Q", revolve crank-shaft clockwise to bring the blade frame to its furthestmost forward position, to be sure the rear blade holder will not strike the vise or work when the blade is in its lowest position; and shift the vise forward in the T-slotted bed as necessary to affect such safe clearance before allowing the machine to run. If desired angle is appreciable, such as 45 degrees, it is sometimes more convenient to reverse the position of the vise -- to turn the vise around with fixed jaw forward. Of course, when vise is set off-square, only the long machine-bolt must be depended upon for holding the vise secure, and it must therefore be drawn extremely tight or "home".

MAINTENANCE

The fit of the square slide bar of the blade frame in its V-bearings requires periodic inspection, and adjustment must be made before the fit wears to noticeable looseness. If you can "feel" a noticeable looseness when you "rock" the blade frame sidewise by hand, adjust the V-bearings as follows; observing the following CAUTION:

STAND CLEAR of the blade frame at all times during both adjustment and testing of such adjustment of the V-bearings, as a tight bearing will cause the blade frame to suddenly "jump up" and could injure you. Lift blade frame to the extreme height-stop and lock it in that highest position by means of the feed wedge 2-12, then tighten down friction thumb-screw "N" (with a wrench) so that the blade frame cannot feed downward away from the height-stop. Start the machine running. With two wrenches, one on the head of rear set-screw "Z" and the other wrench on its jam nut, tighten down that rear set-screw very slowly to the point where its clamping action on the V-bearing cap causes the motor to slow down (or the belt to slip on belt-driven machine); and quickly loosen that set-screw very slightly to the point where the motor regains full speed (or belt does not slip) when you have tightened the jam-nut of that set-screw. With the machine still running, and being sure that the feed wedge is still holding the frame locked to its height-stop, make the same adjustment on the front set-screw "Z". Then stop the machine and loosen feed-wedge slightly, to allow a slight freedom of up-and-down or radial movement of the blade frame. Still standing clear, start the machine running. If the blade frame has a tendency to "jump", one of the V-bearings has been set too tight; loosen as necessary to the point where any tendency of the blade to "jump" ceases. Then stop the machine, loosen thumb-screw "N" withdraw feed wedge to lower saw frame, and again "test" or "prove" your bearing adjustment is correct by running the machine in all positions of the saw frame, from top to bottom of its vertical arc. If the saw frame "jumps" in any position, it is necessary to loosen whichever bearing is set too tight.

Normally, other than making repairs for excessive wear or accidental damage, no other periodic maintenance procedures are necessary to maintain this extremely simple machine. But frequent LUBRICATION must not be overlooked. See above Lubrication Instructions.

Speed. Motor driven machine has 1/2 H.P., 1800 RPM motor, geared to run machine at constant speed of approximately 65 strokes per minute.

Belt driven machine has 20" diameter x 3-1/2" face pulley, and must be belted to run at not more than 70 strokes per minute.

MARVEL BUILDS A COMPLETE LINE

The No. 2 MARVEL Hack Saw which this booklet describes is an extremely simple metal-cutting hack saw intended only for intermittent or "occasional" use for maintenance, repair, and tool shops wherein speed of cutting is not as important as is convenience, simplicity, and availability of this inexpensive machine. Although this simple MARVEL machine will cut faster than any other hack saw within its price and capacity class, it is not to be considered a "high-speed" or "production" machine. If you are interested in truly "high speed" and quantity-production sawing, contact your local machine tool dealer or write Armstrong-Blum Mfg. Co., Chicago 39, Ill., for a complete MARVEL catalog describing many models of hack sawing and band sawing machines (even up to 24" x 24" capacity) of truly high-speed, production types. And to make all your hack sawing SAFE, always insist upon genuine MARVEL High-Speed-Edge Hack Saw Blades -- the original, genuine NON-BREAK-ABLE high speed steel blade.

INSTALLATION PLAN NO. 2 BELT DRIVEN MARVEL DRAWCUT HACK SAW

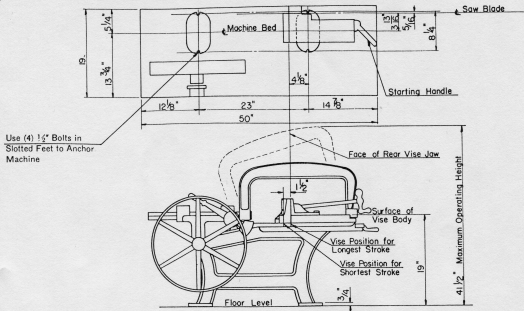

INSTALLATION PLAN NO. 2/MI MOTOR DRIVEN MARVEL DRAWCUT HACK SAW

