

Turning lathes

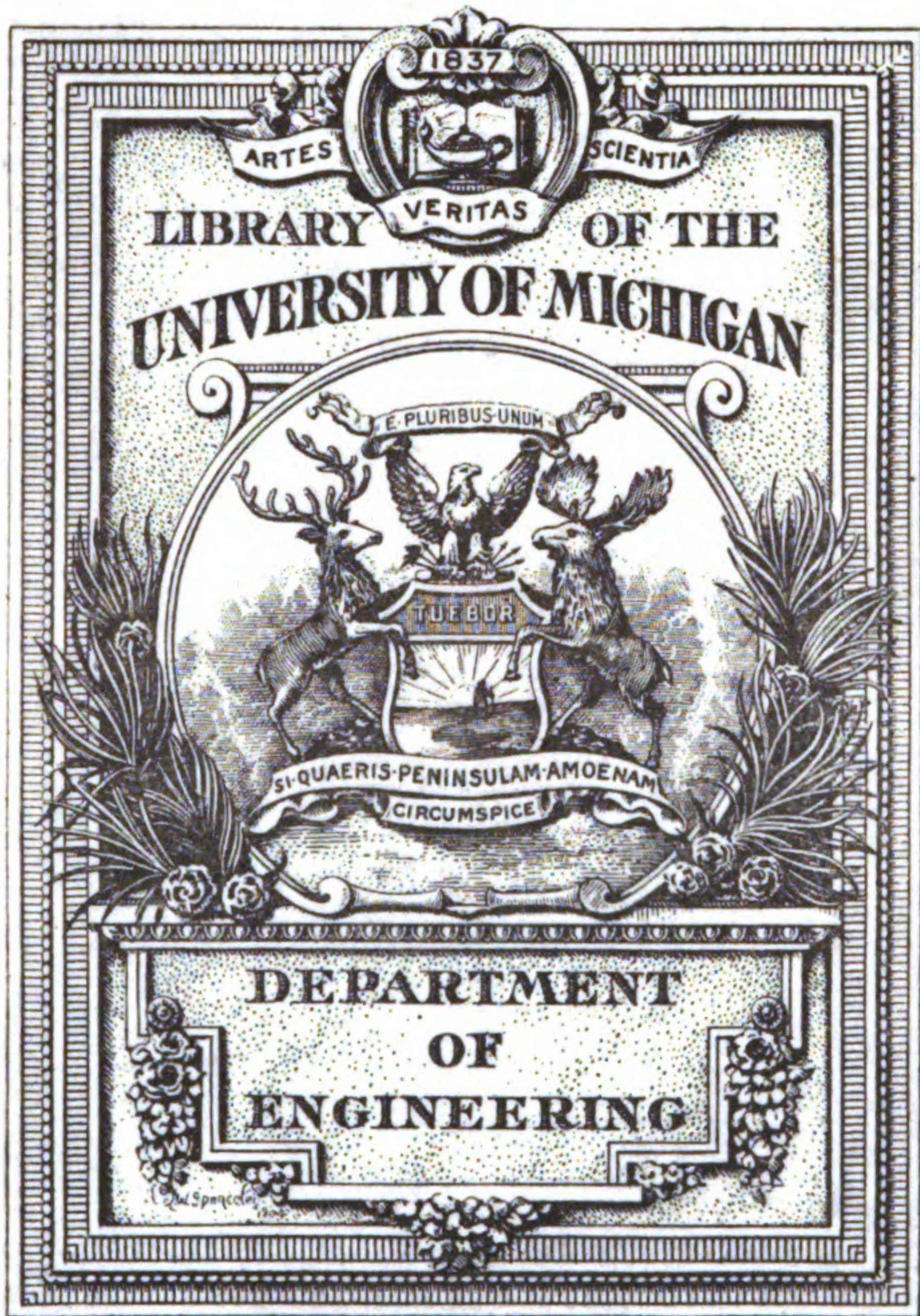

East Engin.
Library



East Eng

Library

TJ

1218

.1.95



TURNING LATHES.

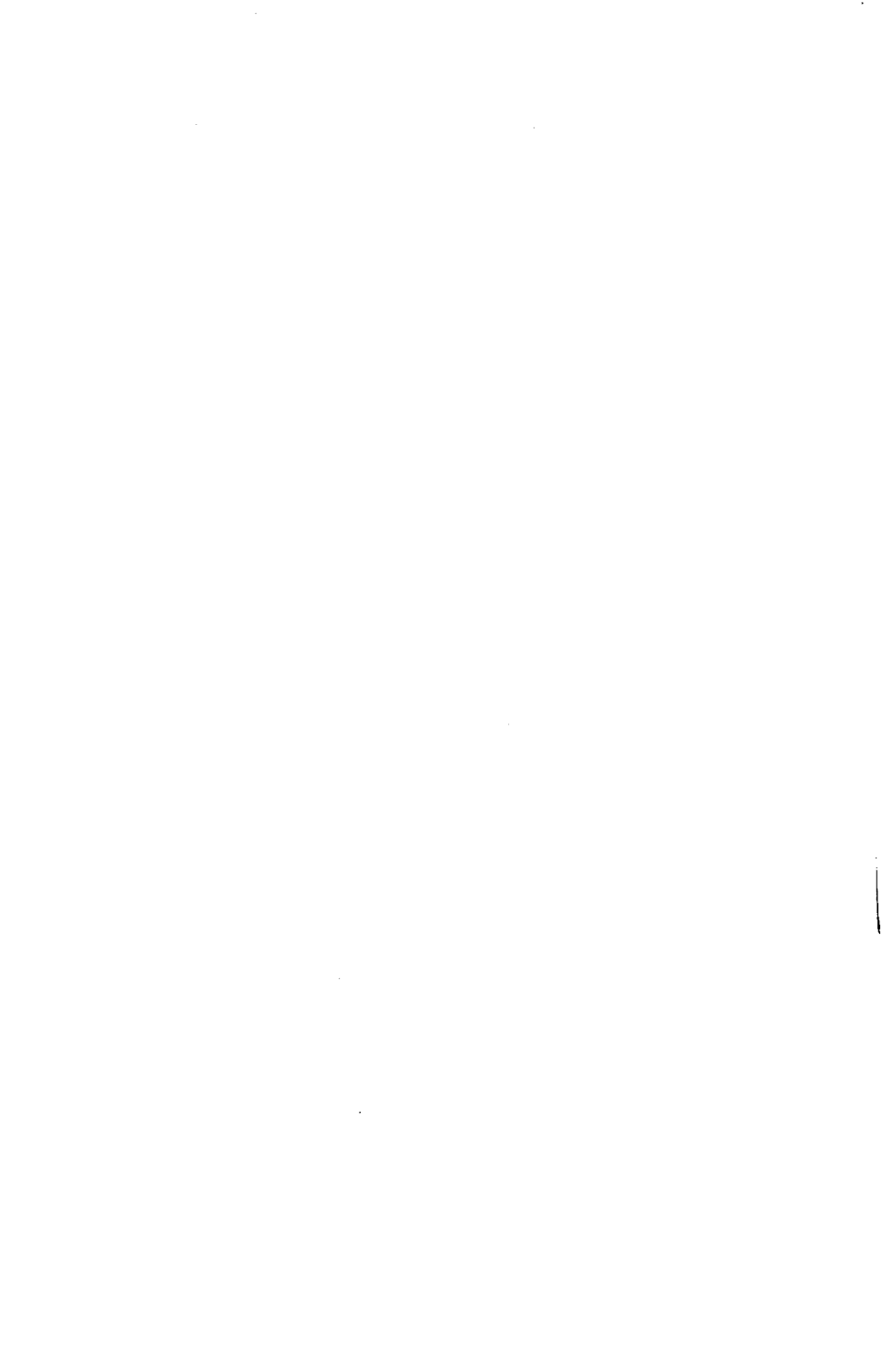

30225

TURNING LATHES:

A MANUAL
FOR TECHNICAL SCHOOLS AND
APPRENTICES.

A GUIDE TO TURNING, SCREW-CUTTING,
METAL-SPINNING, &c., &c.

WITH 194 ILLUSTRATIONS.

EDITED BY JAMES LUKIN, B.A.
"

LONDON:
E. & F. N. SPON, 125, STRAND, W.C.
NEW YORK: 35, MURRAY STREET.

1888.

LONDON :
PRINTED AT THE BAZAAR PRESS, 170, STRAND, W.C.

P R E F A C E .

NOT unnaturally might the question be asked, "Of what use is it to multiply books on the Art of Turning? Holtzapffel and Evans have covered the entire ground, and taught all that it is possible to teach upon the subject; and, for such as cannot afford to purchase the above costly volumes, there are several smaller treatises of a more elementary and less expensive character." All this is true, yet there may exist a demand for more. Just as a new shop is frequently opened in the midst of other old-established ones, and may, and very often does, obtain at least its fair share of patronage, so is our little, unpretending volume presented to the public, and asks very humbly a little of the patronage which the world of Amateur Turners is able to bestow. If it tells a tale already told by others, it may possibly tell it in a different way. If it gives a lesson upon the principles and practice of Turning, it is quite possible that such lesson is more simply and intelligibly conveyed than it has been by previous teachers. This has, indeed, been the special intention and aim of the writer—to meet the frequent complaint that there is no work sufficiently elementary for a tyro who as yet knows nothing at all about a Lathe, and to whom such terms as Mandrel, Headstock, or Chuck, convey no meaning whatever. In the present volume no knowledge of Lathes or tools is pre-supposed, and therefore everything is explained in detail, with the necessary illustrations. The book will suffice to set any tyro to work, and actual practice must do the rest. We give the Alphabet of the Turner's Art, and the work of the reader must be to make the necessary combinations of letters to illustrate the very beautiful language of which it is capable. But it must not be

forgotten that you may put a pen into the hand of a child, and the result may be a blotted and unsightly page; and to show a learner how to hold a brush will not make him an artist. And however carefully we may explain the method of working, we cannot give to the beginner the skill that will make him a Turner—all we can do is to give him a fair start, and guard him against error; and this we have in the following pages endeavoured faithfully to do.

CONTENTS.

CHAPTER	PAGE
I.—DESCRIPTION OF THE LATHE	1
II.—TOOLS, AND HOW TO USE THEM	14
III.—HARD-WOOD TURNING	34
IV.—METAL TURNING WITH HAND TOOLS	53
V.—SLIDE-REST WORK IN METAL	63
VI.—THE SELF-ACTING LATHE	80
VII.—CHUCK-MAKING	96
VIII.—TURNING ARTICLES OF SQUARE SECTION	101
IX.—SCREW-CUTTING BY SELF-ACTING LATHE	104
X.—THE OVERHEAD DRIVING APPARATUS	115
XI.—CHOOSING A LATHE	121
XII.—GRINDING AND SETTING TOOLS	125
XIII.—METAL-SPINNING	129
XIV.—ORNAMENTAL WORK	138
XV.—THE MILLING APPLIANCE	150

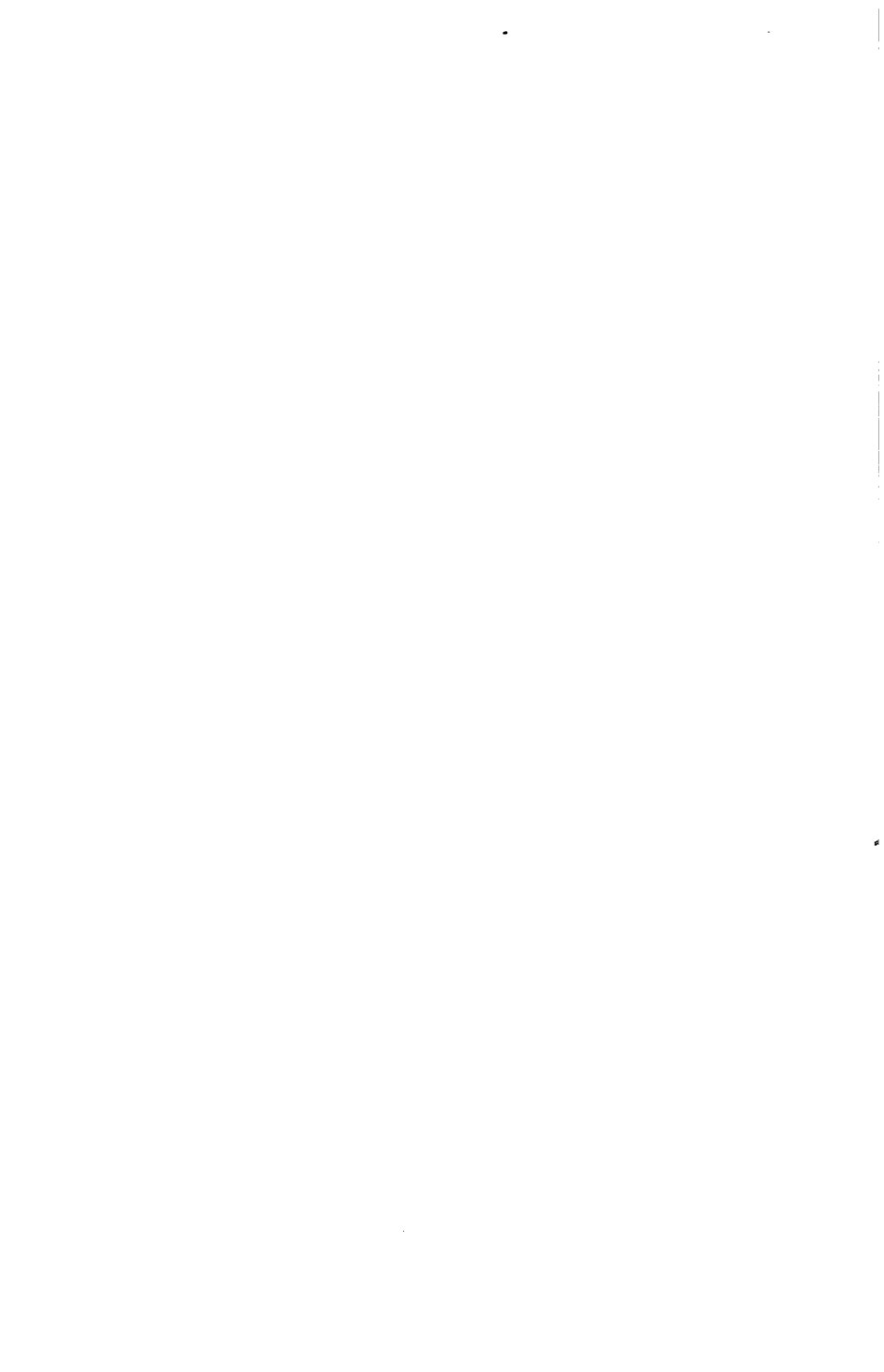

TURNING LATHES.

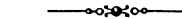

CHAPTER I.

DESCRIPTION OF THE LATHE.

THE novice who has never examined a Lathe, but, having seen others using it, thinks he should also like to try his hand at the work, naturally wants to know its construction. He hears of chucks, and mandrels, and poppets, but the terms convey to his mind nothing but mystery. We shall, therefore, at once enlighten him. Beginning at the stand, he will see two cast-iron uprights, supporting between them parallel bars, nicely planed. These are called the standards, and are sometimes, but not very generally, made of wood. The parallel bars are called the bed, sometimes gantry, which appears to be an American coinage, not very expressive, and decidedly ugly. Half-way between the bed and the floor, the crank axle is suspended, generally upon centres or pointed steel screws; but sometimes this axle runs in brasses, called bearings or bushes, and sometimes it rests upon small turned wheels, called friction wheels, which are supposed to give it an easier motion. At the lowest part is hung a treadle for the foot, and this is connected to the crank by an iron hook, or by crank chain passing over a roller in the treadle bar. This gives a smooth rolling motion. Sometimes the crank hook is called the pitman.

The bed of a Lathe is usually made of two bars in a single casting, planed quite flat on the top and edges. It may be of beech, mahogany, or hard wood, but it is now so easy to obtain complete Lathes of iron, and they are so cheap and convenient, that it is not worth while to build them up at home. In some of the small Lathes, there is no crank axle, but the flywheel is hung upon a short bolt or stud, which screws into the left standard. The crank is then merely a pin fixed into one of the spokes of the wheel. Standing on the bed are two poppets, or, as they are also called, headstocks. The one on the left hand is permanently fixed in place by a strong bolt and nut. This headstock carries a small wheel or pulley, the axle of which is the mandrel. The pulley is turned with grooves for the Lathe cord; that of smallest size giving the greatest speed. This is used for wood, and the slower motion is for metal. Soft wood, like deal, needs the quickest speed of all to make it cut clean. The harder woods, and also bone and ivory, are usually turned at a slower rate.

The mandrel is the most important part of the Lathe. It is made generally with the conical neck passing through a hard steel or gun-metal collar in the headstock, while its other end rests on a hard, pointed screw of steel, which is called the tail pin. By means of the latter, any wear of the neck or collar can be taken up by screwing the tail pin so as to push the mandrel neck forward into its collar. This must always be attended to, as the mandrel must turn very easily, but without the least shake. There are oil-holes drilled in the top of the headstock, and lubrication must never be omitted. The best sewing-machine oil should be used, and a few drops of paraffin will make it still more suitable. Never use vegetable oil, like linseed or olive, Lucca or colza, if it can be avoided. Sperm oil is good, either alone or with paraffin, and if only olive or salad oil is obtainable, always add paraffin to it, as it materially improves it. A good lubricant makes a surprising difference in the running of a Lathe. The crank axle screws, and also the crank hook or chain, must also receive due attention in this respect; likewise, now and then, the bearings of the treadle.

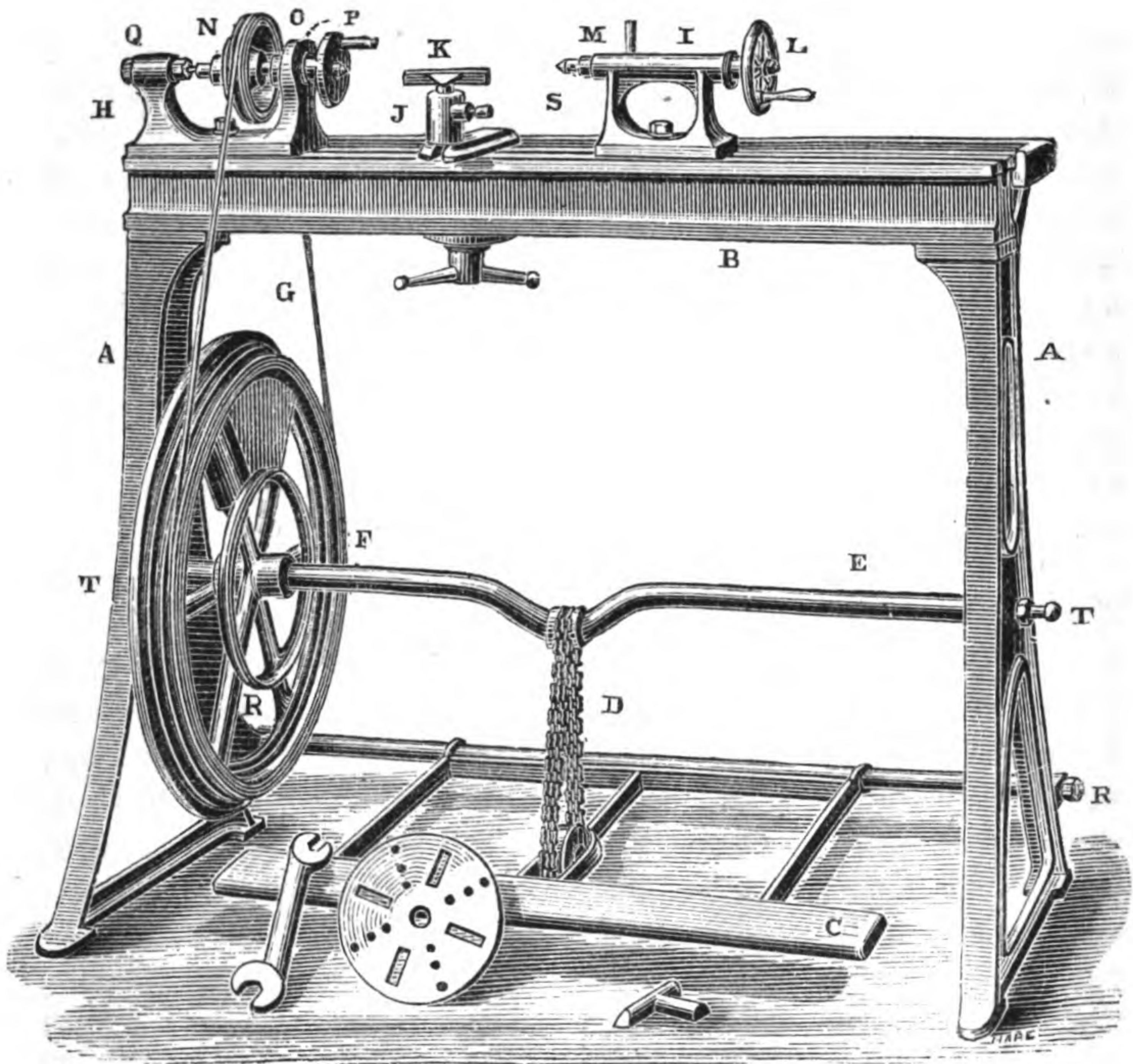

PLATE I.—PLAIN FOOT LATHE.

The second Lathe head, or back poppet as it is usually called, is movable along the bed, and can be fixed at any point by the bolt and nut attached to it. The upper part is bored out accurately to carry the cylinder, or smooth, round bar into which the pointed steel centres fit, which are used to support work while it is being turned. This cylinder is advanced and withdrawn by a hand wheel at the back, which carries a screw working into a nut in the cylinder. All this is out of sight in the upper part of the poppet. Between the poppets stands the hand rest, on which the tool is supported. This can be placed where needed, and the upper part, or tee, can be raised or lowered at pleasure, according to the size of the work that it is proposed to turn. This hand rest is often replaced by the slide rest, if metal is to be turned; but a good deal can be done without this addition to the Lathe, which can be added at any time, after wood turning has been thoroughly mastered.

In the illustration (Plate I.), all the parts above described are lettered as follows:—

- A, A, Standards.
- B, Bed or gantry.
- C, Treadle.
- D, Crank hook, pitman, or chain gearing.
- E, Crank axle.
- F, Flywheel.
- G, Lathe cord.
- H, Fast headstock.
- I, Movable headstock or back poppet.
- J, Hand rest; and K, its T or tee.
- L, Hand wheel to move M, the cylinder.
- N, Mandrel, with its pulley, O.
- P, Screw for chucks.
- Q, Tail pin.
- R, R, Treadle centres or bearings.
- S, Movable back centre.
- T, Bearings or centres of crank axle.

We now come to what are known as chucks. These are contrivances by which the work to be turned is secured to the Lathe mandrel, and they vary according to the size and

nature of the work, such as whether it is long or short, whether to be bored or hollowed out, or solid; and also whether it is of wood, ivory, or metal. Chucks are, therefore, rather numerous, but for general use we may readily make an inexpensive selection. Plate II. gives illustrations of several chucks. Nos. 5 and 6 are main or adapter chucks, into which fit many of the smaller ones, such as No. 1, the fork or prong chuck, for soft wood, used with the back centre to support the work at its other end. No. 2, the cross or blade chuck—a capital one for hard or soft wood. A saw cut is made at the end of the piece, crossed by another at right angles. Into these the blades fall, and the work cannot shift or slip. The back centre is needed as in the last case. No. 3 is the square hole chuck, made to take carpenters' boring bits, or rods of metal squared to fit, and for many similar purposes. This is a very useful chuck. No. 4 is a solid chuck of gun-metal, that can be drilled out to any desired size. No. 7, taper screw, an indispensable chuck, for holding short bits of stuff for boxes and other hollow work. These are also sometimes held by means of No. 8, a plain face plate with holes countersunk at the back. The work is attached by ordinary wood screws. No. 9 is a mandrel for circular saws, emery wheels, buffs, &c. When required for saws, a saw table is needed, which is fitted into the socket of the hand rest, or fastened upon the bed. No. 10, a bell chuck, with clamping screws, for holding short bars of metal. It is less used since the scroll chuck was invented; but is a good contrivance, its only fault being that it is a knuckle-duster. Made with very thick metal, however, the screw heads can be countersunk. Nos. 11 and 12, the amateur's self-centring scroll chuck, often called American, as it has been chiefly developed and perfected there. It has one or two sets of jaws, which draw together concentrically, by means of the key, and hold drills or work truly and securely. Of late years these chucks have come into very general use. They are of all sizes and prices: the 2in., 24s.; 4in., 34s. They are fitted to a face plate screwing on the mandrel; the smaller ones on a cone.

No. 13 is a four-jawed chuck, of which each jaw is inde-

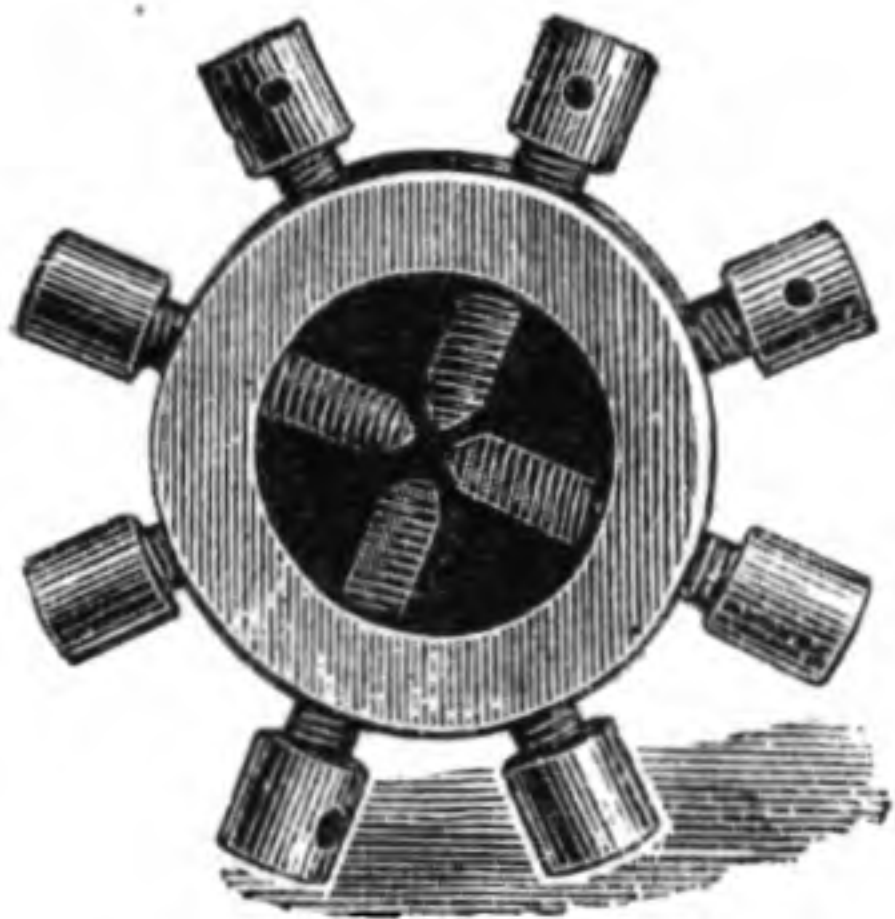
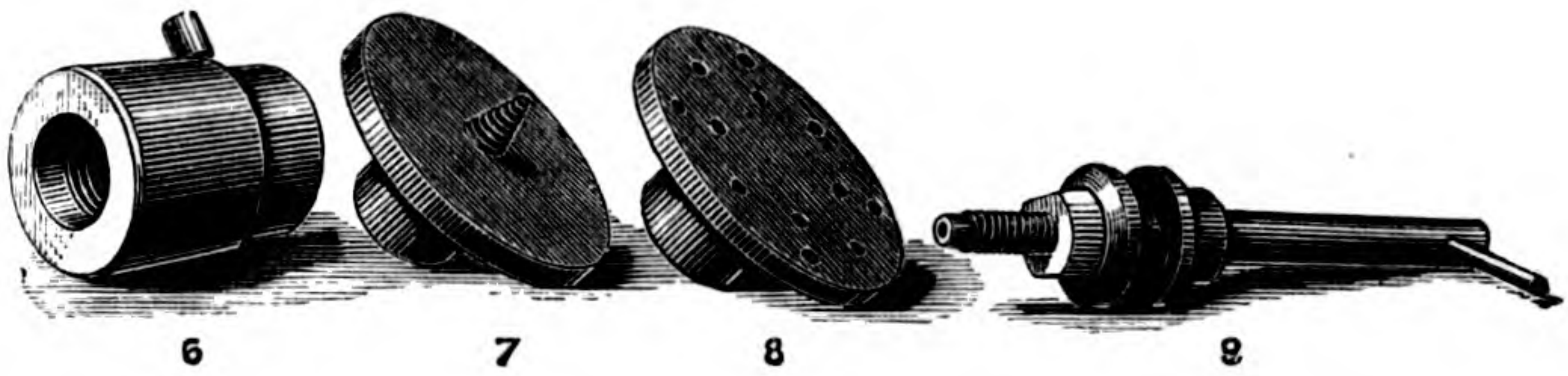
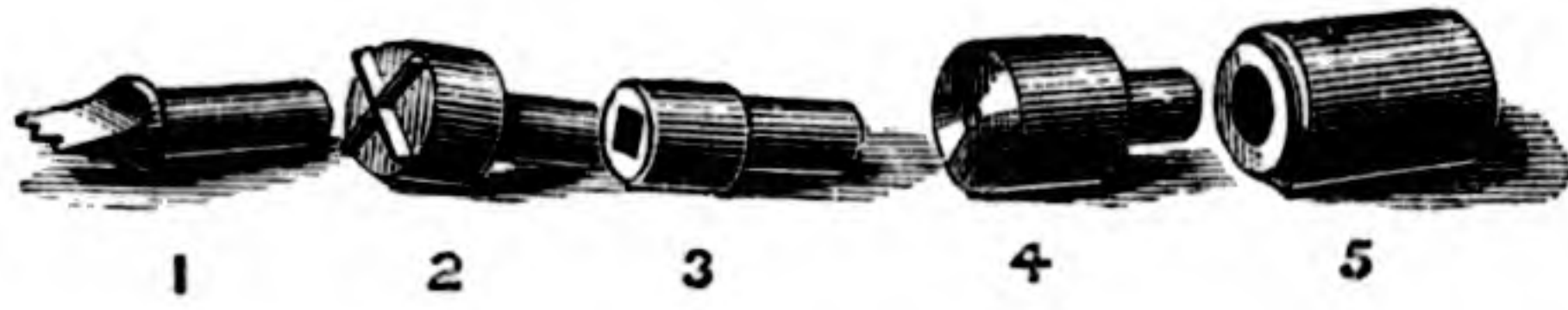

10



11

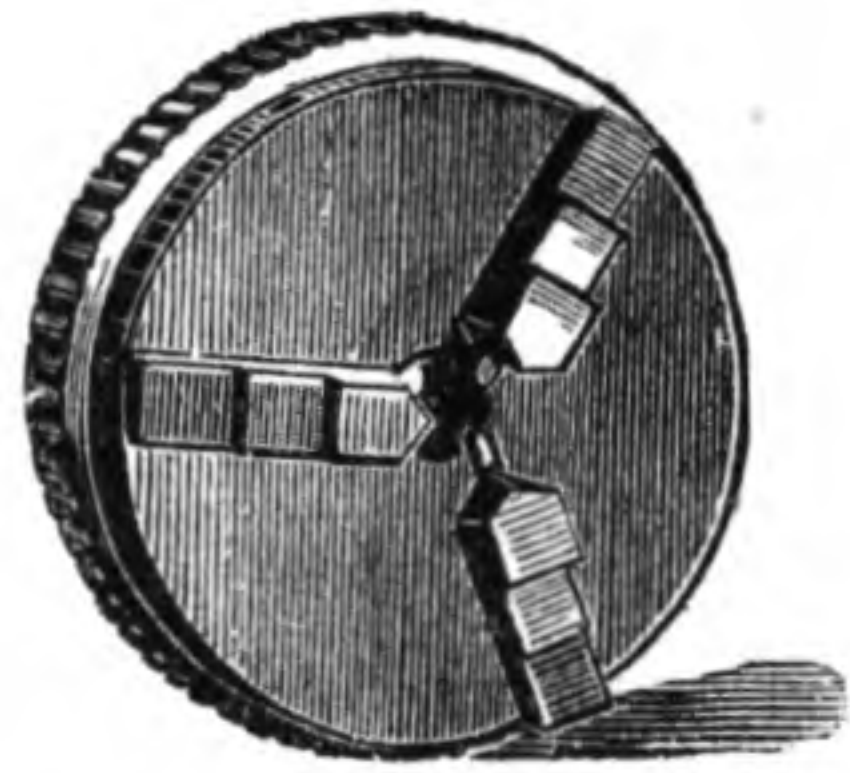

12

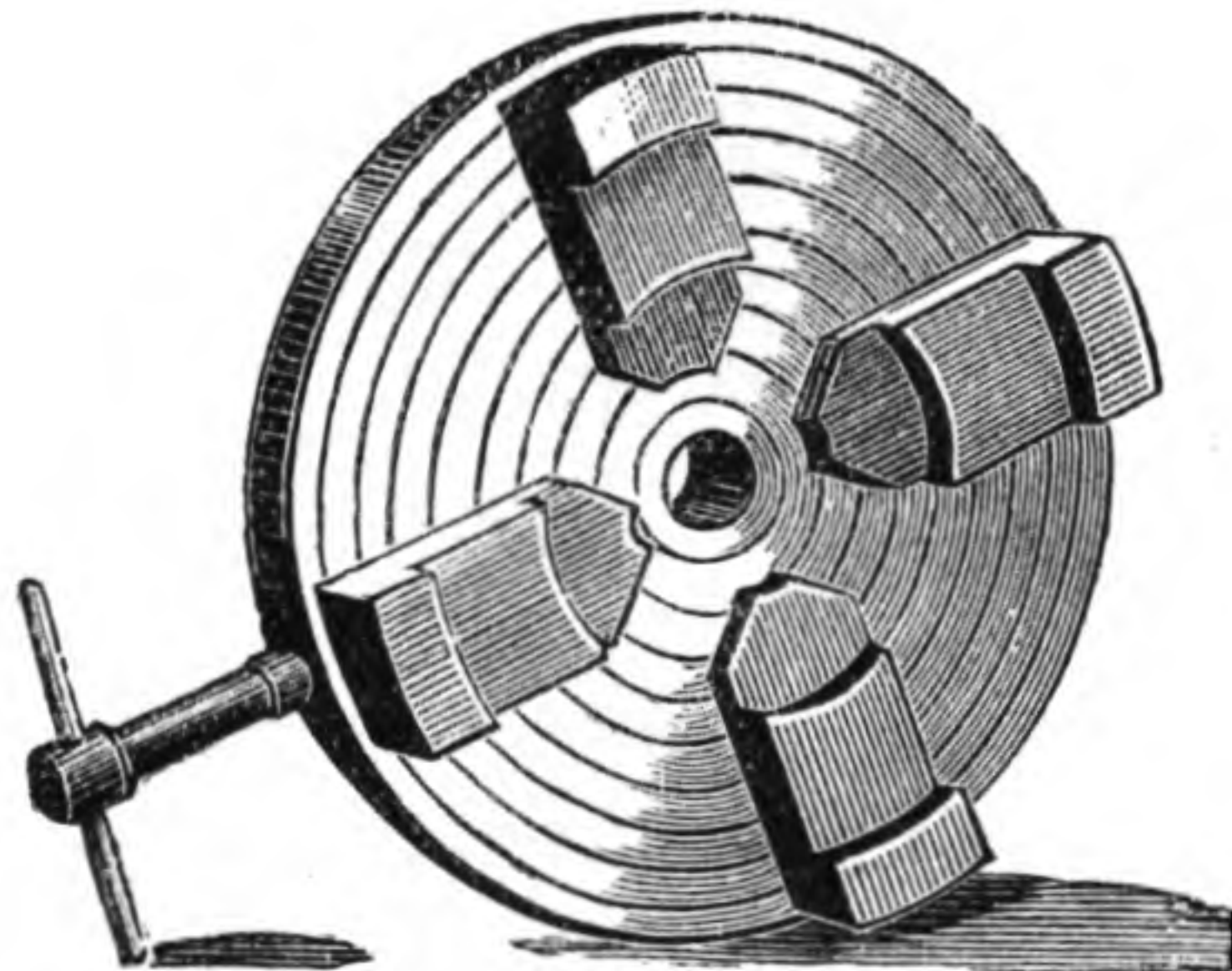

13

PLATE II.—LATHE CHUCKS.

pendent of the others, so that work can be held eccentrically when desired. It is an excellent chuck, holding very firmly; it is, in fact, an engineer's chuck, and is seldom of less diameter than 6in. Fig. 1, cup chuck, made in iron or gun-metal, from 1in. inside diameter upwards. Before self-centreing chucks were invented, every amateur's Lathe was fitted with a dozen or two of these. They are useful as ever, and a few



FIG. 1.—CUP CHUCK.

may well be added; the wood is simply driven into the chuck, and so secured.

The amateur will soon learn to make boxwood cup chucks, which will prevent any necessity for a large supply of metal ones. These are always very largely used, and are hollowed out to suit any work in hand; they soon accumulate, and when used up are easily replaced. A day at chuck-making



FIG. 2.—PLAIN DRILL CHUCK.

affords capital practice; the method is given on a later page. The advantage of a metal chuck is that it always screws up to run truly; it is usually plugged with wood, and this is turned out to the size necessary. Fig. 2, a plain drill chuck, with $\frac{3}{8}$ hole; a smaller one fits inside for drills of less diameter in the shank. Fig. 3, face plate, used for large work, secured to it by variously shaped clamps and bolts; it is of extensive

use for metal-turning. Fig. 4 is a neat little jeweller's chuck for very small saws, circular brushes, and buffs; it also holds drills of small size. Another drill chuck is here shown, called the Essex (Fig. 5). The parts are numbered separately. 1 is the complete chuck with drill. The shank is turned to a

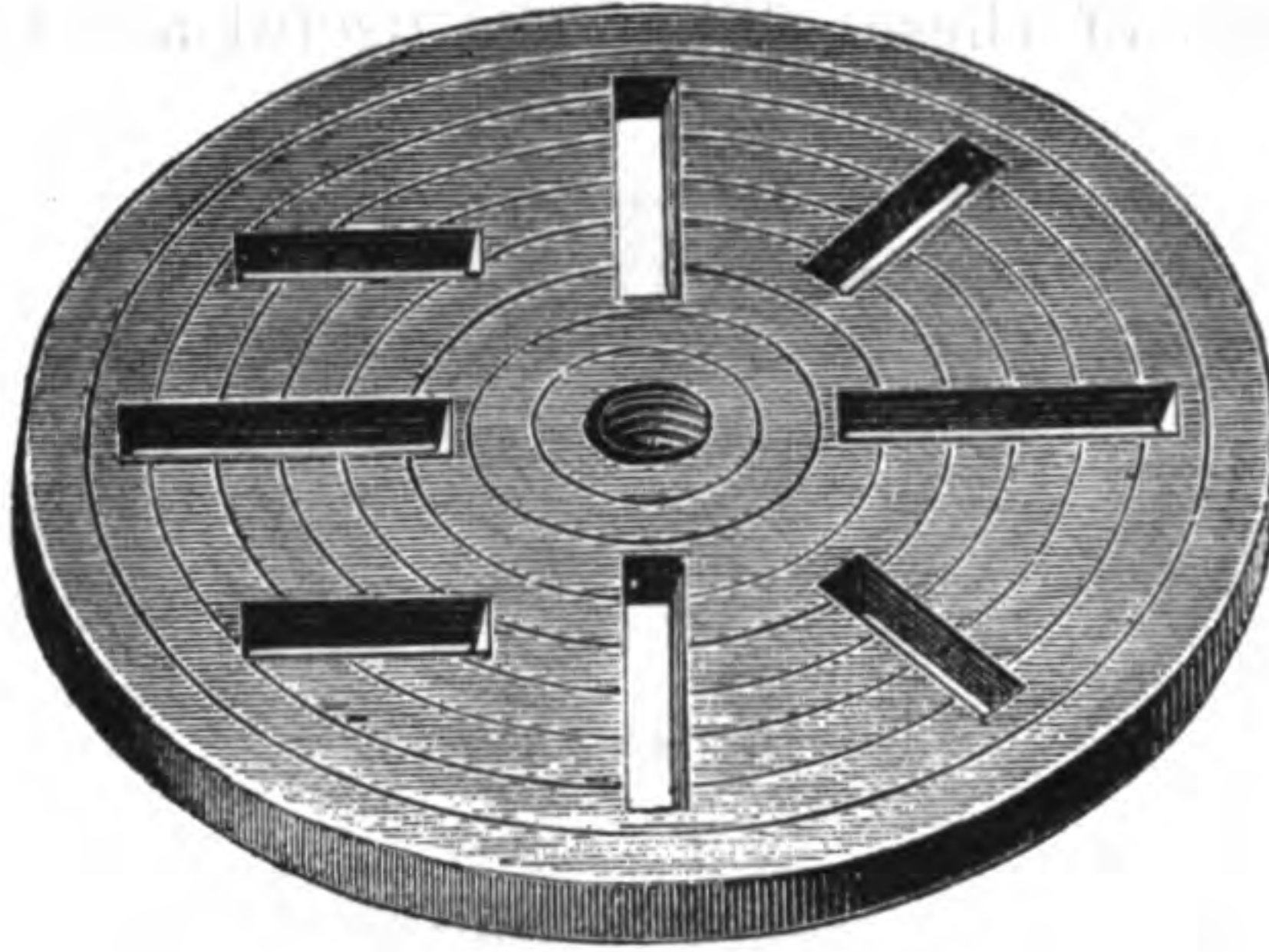

FIG. 3.—FACE PLATE.

gentle taper, or long cone, and fits into a taper hole in a receptacle chuck, truly bored out to a similar angle. 2 is the outer case; 3, the cap, which is conical within, and when screwed on it compresses the jaws (4), of which two sets are supplied, one for very small, and the other for larger drills. 5 is the wrench fitting the hexagonal top of the cap. This is

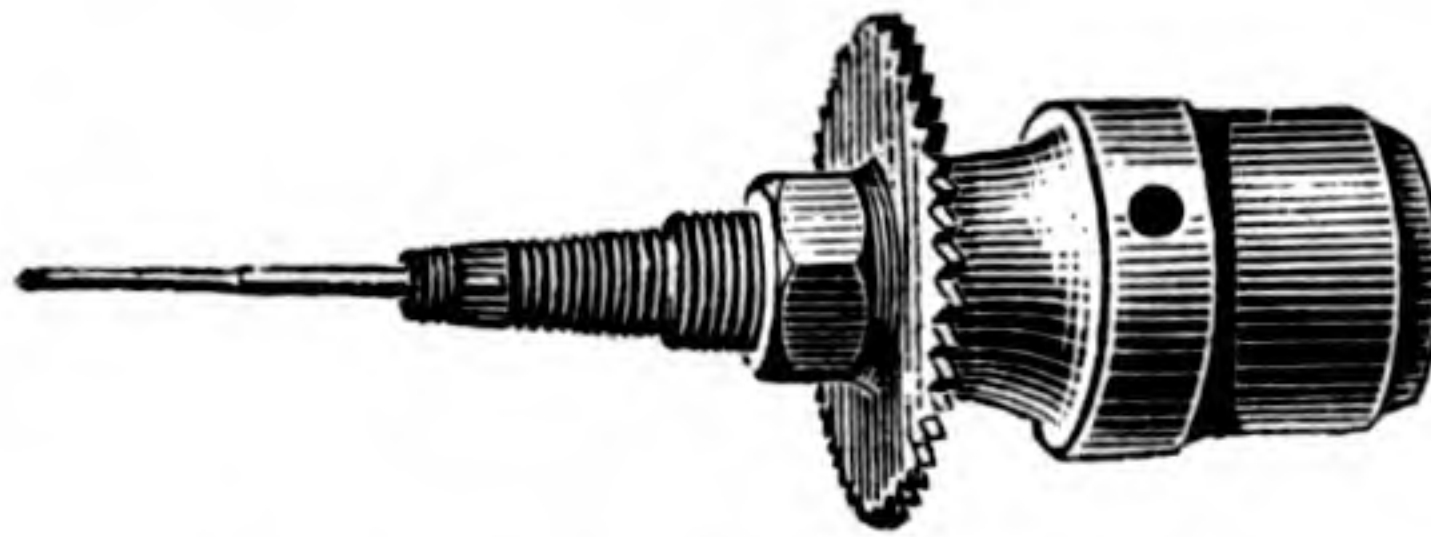

FIG. 4.—THE JEWELLER'S CHUCK.

the cheapest of all the adjustable drill chucks, the price being 10s. 6d. It will hold drills up to $\frac{1}{4}$ in. A larger size is made with four jaws, to take drills of $\frac{1}{2}$ in. diameter in the shank. These are the chucks chiefly used for general work, but there are one or two more needing description. That used for turning bars of metal is called a driver chuck, and is

composed of two essential parts—viz., the carrier plate, or driver chuck, and the carrier, which is of various forms,

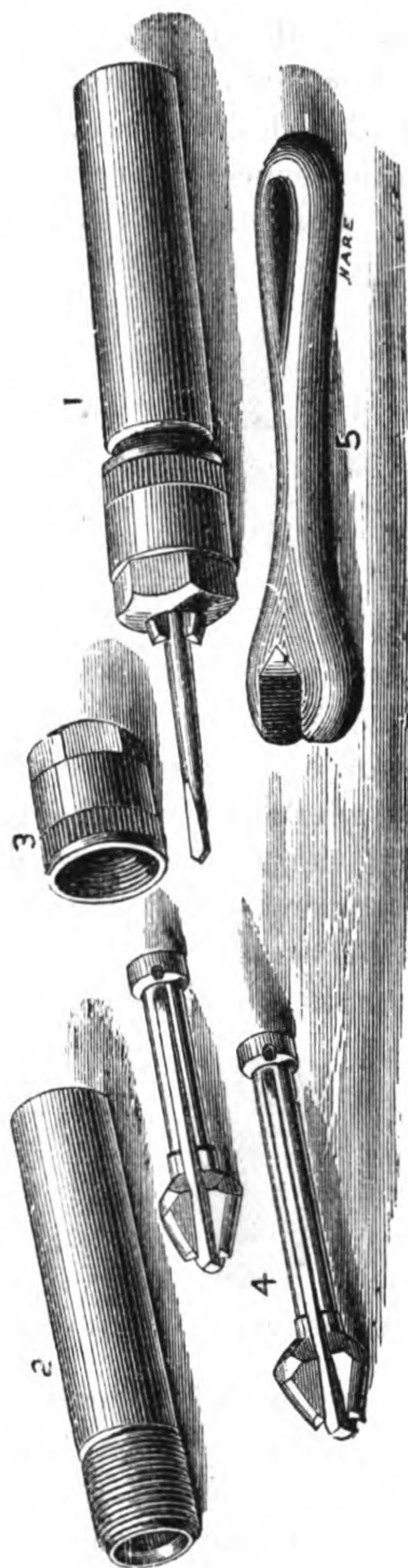

FIG. 5.—THE ESSEX CHUCK.

but usually like that of Fig. 6. The chuck is like the main or receptacle chuck, a centre point fitting into it; but, made

crosswise through it, is a squared hole, receiving a cranked arm, which is secured by a side screw, and is, consequently, adjustable. The bar to be turned is mounted "between centres" — *i.e.*, supported at one end by the point of this chuck, and at the other by the point of the back poppet, shallow holes called hollow centres being drilled at each end, exactly at the respective centres of the ends of the article to be turned. One of the carriers is now selected,

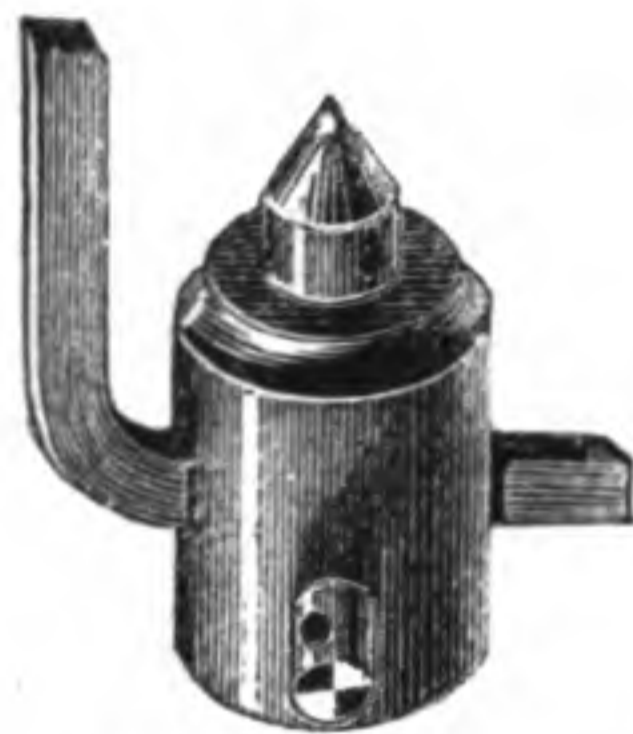

FIG. 6.—DRIVER CHUCK.

which is of suitable size, and this is clamped on the end nearest the mandrel. The tail of this catches the cranked arm of the driver, or pin of the carrier plate, if that form is used, and causes the whole to revolve together. The bar is then turned as far as the tool can reach, and afterwards it is reversed, and the carrier is attached at the finished end, after which that part previously covered by the carrier is turned. When the chuck is made like a face plate with a



FIG. 7.—SELF-CENTREING CHUCK (WOOD).

projecting pin, it is often termed a "catch plate." This is the chuck almost always used for iron bars, and it has this advantage, that, if the hollow centres are left in the ends of the work, it can at any time be re-mounted, and will run as true as before. With other chucks it is always difficult to readjust work centrally.

One other deserves mention in this place, on account of its

convenience, but it must be always used with the back centre. It is of metal, but easily made of boxwood. It is a cup chuck with thicker walls, and is hollowed out conically, and the inside is then grooved to form ridges. A piece of wood placed in it centres itself and is held by the ridges catching any rough parts sufficiently to resist the action of the turning tool. It is shown by Fig. 7. A block of boxwood thus hollowed, with grooves cut by a gouge, will answer just as well. This is a capital chuck for holding bars of wood for tool handles; a finished piece of work can also be centred in it for polishing or altering. Two or three wooden ones, with conical holes of from lin. to 3in. at their largest diameter, will be serviceable. Sometimes, a chuck is made with a square taper hole an inch or more across the face, and then the bars of wood are squared; but the other will take them without preparation.



CHAPTER II.

THE TURNING TOOLS.

FOR wood-turning, which is probably what a novice will, and certainly ought to, commence with, the gouge and chisel are the special tools, and are almost the only ones to be met with in the workshop of an ordinary turner. With these alone may be turned solid work of all kinds, besides a good deal of hollow ware, as it is called. It is true that, for turning hard wood, many others are used, but, for the present, at any rate, we may with advantage pass them by. The gouge is the roughing-down tool, and the chisel is used to level all ridges and give a finish to the surface. After this, a bundle of shavings held against it while it rapidly revolves, is all that should be necessary to polish it; but, for a time, at any rate, fine glass-paper will very likely be found necessary. The finish produced, however, by a sharp chisel, efficiently used, beats all that can be obtained by any amount of papering. The tool, in fact, leaves a high polish.

We will begin by turning a tool handle, which will suffice very well to teach the way of setting to work. Put the prong or fork chuck on the mandrel—or, if preferred, the cross chuck or that last described may be substituted; after a little practice, one or the other will have preference. The fork or prong is not a very sure one to hold, and sometimes the work will slip round, which it cannot do upon the cross or blade chuck.

Now cut a piece of beech or ash, or other suitable wood

—elm will do, but the first-named are better—or a bit of acacia will serve, which is of a yellowish-brown tint, and is a capital turning wood. Saw off a bar about 6in. or 7in. long, and 1½in. in diameter or thereabouts, cutting it off as squarely at the ends as you can; chop off the corners if it is square, so as, in a rough way, to round it slightly. Make a little hole in each end as centrally as possible, just to give a slight entrance to the Lathe centre and the central point of the prong chuck, or make saw cuts if the cross chuck is used. Then loosen the back poppet, and slide it forward until there is just room enough for the wood to be mounted. Screw up the nut so as to hold the poppet securely, and then, turning the hand wheel, secure the work in its place, taking care that the cutting edges of the fork chuck, if it is used, get a good hold by sinking into the wood. If this is very hard, it may be better to make a cut with a saw across the end, to receive the chuck edges; but it will not be necessary to do so with beech, ash, or elm, nor, of course, with deal, lime, sycamore, willow, and other such soft woods. These, however, are not very useful for tool handles. Indeed, of all woods for general turning, beech is most desirable.

Now start the Lathe, causing the work to revolve towards you, and see if the wood runs fairly true, which it is sure to do if the holes in the ends were central. Put just one drop of oil on the point of the back centre. The next thing to do is to place the rest as near as it will go without touching the wood, securing it by the hand nut below the bed, and also setting the tee so high as to stand a little lower than the centre of the work. This is also to be secured by its side screw. The gouge is now to be used thus: grasp the handle firmly with the right hand, palm upwards, and lay it on the rest with its hollow side up, and the whole tool not horizontal but inclined somewhat by lowering its handle. The blade is to be grasped by the left hand with knuckles upwards, and very near the rest, upon which it can thus be held down tightly, while at the same time it is shifted along the rest as the work proceeds. And here will the tyro's first difficulty be met with.

The wood as it revolves will strike the gouge, and cause

it to jump about on the rest, and, when trying to prevent this, he will forget the treadle, and the Lathe will stop or run backwards. But it is a case of "Never say die!" Keep cool. Do not push the gouge too forward, and presently you will get the knack requisite, and the cutting will proceed, not very well at first, but fairly. The best way is not by any means to run the gouge along the rest, as will be done after a little practice, but to hold it so as to cut a little bit at a time, beginning at the end next to the back centre, and so cutting by successive steps till the whole piece is fairly rounded. Then, using the side more than the point of the tool, it will not be difficult still further to level the surface, and, indeed, so nearly to finish it that the chisel, which is far more difficult to use, may be dispensed with, and the work finished by glass-paper.

This is, however, not to be dreamed of after mastering the use of the chisel, but only permitted for one or two introductory essays. And for the first lesson, though I have suggested a tool handle, I would not recommend one requiring a curved shape. It would be better at first to make it like A on Plate IV.—*i.e.*, only a long, straight taper down to the ferrule. This, indeed, is a good form to adopt for files and many hand tools, though seldom used for such as belong specially to the wood-turner. There is, however, great difference of opinion as to the best form, and also as to the length of the handle. Chisels and gouges usually have much longer ones than those used for metal and hard wood or ivory. The ferrule is generally sawn off a piece of brass tube of the requisite size, or from an old gun-barrel, or any bit of thin tube. At some shops they can be bought cut ready for use, but in most towns and villages suitable stuff may be found; and here let me observe that the young turner should be constantly on the look-out for odds and ends of wood, metal, ivory, or bone, of which a well-selected assortment will often supply an unexpected demand. A hack saw, consisting of a steel frame with a thin saw stretched across it by a tightening screw, is used to saw metal. Often an old scythe-blade, roughly notched into teeth, is used, and even preferred; but the real metal saw is the neatest and best. The ferrule being

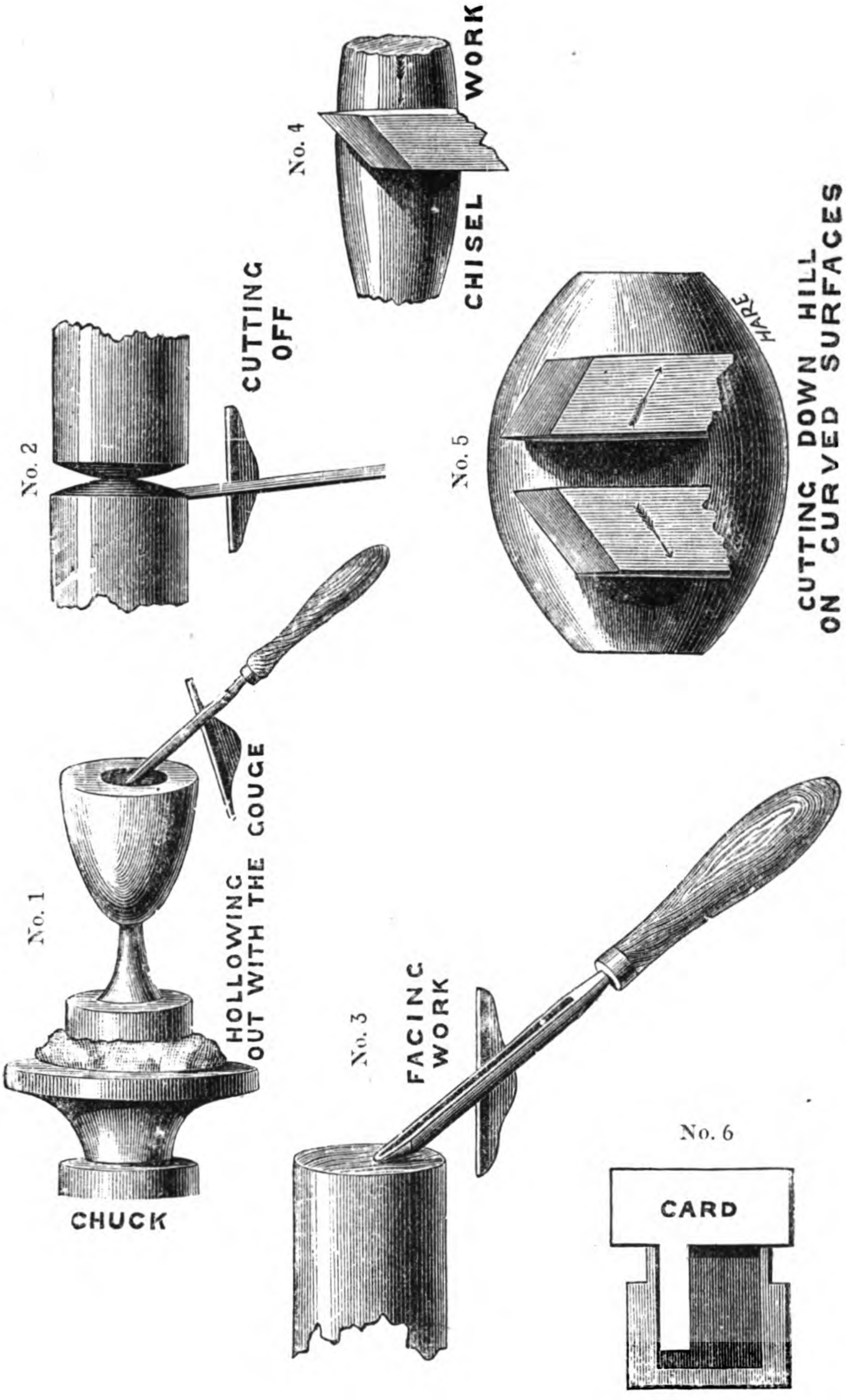

PLATE III.—TURNING WITH GOUGE AND CHISEL.

ready, the end of the tool-handle is reduced to fit it. If the back centre is withdrawn a little, the ferrule can be tried on as the work proceeds, for the wood will run true again when the centre is screwed up as it was before. Ferrules should go on tightly, or they drop off when the wood becomes more thoroughly dry. A little glue or cement of any kind assists to hold them, but it is not absolutely needed. In rounding off the opposite end, the gouge is to be laid on its left side, with the hollow part away from the surface which is being cut. This is the rule: Work down hill when making a moulding or rounding off a surface, and keep the hollow of the tool away from the surface that is being cut (see the Numbers on Plate III.). In turning a ball, for instance, the gouge will lie on its back, when in the diametrical line, and as the cut is carried towards the right hand, it will lie more and more on its right side, the hollow part towards the right hand. Then, starting again down hill the other way, the tool will lie gradually over on its left side; used thus, the tool will leave a clean cut, but otherwise the edge will soon catch in and bite out a chip, or break itself. It is easy enough to cut the piece off with a gouge or chisel (see No. 2, Plate III.) by working a notch, cutting down hill each way till the piece is so far severed as to break off with a touch; after which a pen-knife and glass-paper will finish it off.

THE CHISEL is the plane of the wood-turner, and, rightly managed, will leave a surface so smooth that a touch of glass-paper would spoil it; but it needs to be gripped with a firm hand, and used with decision. Suppose a cylindrical piece of wood to have been turned by a gouge, and that it is desired to finish it to a truer surface than it is possible to produce with a gouge, the chisel is the tool to use. It is not ground straight across, and with the bevel on one side only, as is the case with a carpenter's chisel, but there is a bevel on both sides, and the edge is ground slanting, so that there is formed one sharp point and one blunt one (No. 4, Plate III.). As a rule, the blunt point leads, whether the tool is being worked to right or left (No. 5, Plate III.), and, also, in cutting down hill on a curve or incline. But this tool is not laid flat on the rest, but slightly on edge, for this reason: if laid flat, as

a tyro would probably place it, it could only scrape, and would tear up the fibres of any soft wood. It is, therefore, slightly raised upon edge, care being taken that the upper sharp corner never comes in contact with the wood, or it will hitch in and spoil the work. Only the middle part of the edge, therefore, actually cuts, and this, engaging the fibres at an angle, no longer tears them apart. When there is a rounded surface to be worked, this tool is made to travel, like the gouge, both ways down hill; and so, also, in a hollow, it never sweeps the curve from end to end, but the cuts are carried down each way, meeting at the bottom. It may be conjectured that, just at the point of juncture, the two cuts will not exactly meet, but practice will make them do so. The cut is made so as to reduce the shaving at this point to almost nothing; a slight rub of glass-paper will obliterate any little defect that still remains. After a while, even this will be unnecessary. Of course, a beginner must not expect to succeed all at once with this tool, but I strongly advise him for a long time to work entirely with gouge and chisel, and not to attempt hollow work till he has become an adept at what is solid. Let him turn a set of handles, ninepins, towel-rollers, rolling-pins, ring-stands, chair-rails, and anything else he can think of: drawer-knobs, door-handles, and other articles of curved surface will give him excellent practice, and pave the way for those which require greater skill—a skill only to be gained by steady, consistent, and painstaking practice. I have given drawings here (Plate IV.) of some such articles, including variously shaped tool-handles. The little pilasters will do for rails of book-trays, overmantels, brackets, shelves, and a score of similar articles. A round ruler, well and truly finished by the gouge and chisel alone, may be considered a proof that the young turner has passed his novitiate. Indeed, he may attempt simple hollow work long before his hand and eye are equal to so severe a test of skill.

HOLLOW WARE is chuck work—*i.e.*, the work is held by the chuck alone, the back poppit being pushed entirely out of the way. Very deep or long articles, however, need extra support, by means of a boring collar, of which we need not

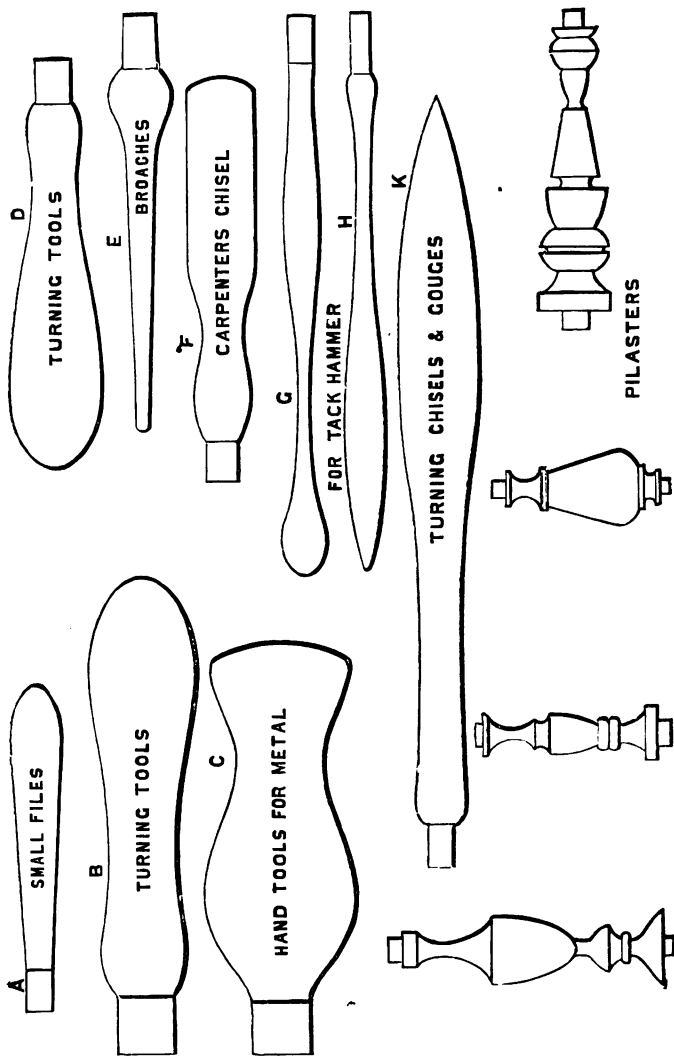

PLATE IV.—TOOL HANDLES AND PILASTERS.

speak further at present. An egg-cup will be a capital thing to begin with. Saw off a bit of beech, birch, or other wood, long enough to serve the purpose, the length and size being easily determined by reference to a pattern. Allow a little more than absolutely necessary, and screw it upon the taper screw chuck, after securing the latter in its place on the mandrel. If care is taken to bore a hole centrally, and not too large, the piece will abut fairly against the face of the chuck, and will run evenly; but to insure this it must be cut off squarely at the end. The back poppet may be brought up to help sustain it while the rougher excrescences are being cut away, and the whole brought into approximate form, after which it must be removed. The outside will present no special difficulty if sufficient practice has been obtained upon solid work, but the hollowing out needs some care, and especially needs a knowledge of how to do it in the best way. The end must be first of all faced nicely, using the gouge, as explained, with its bevelled back against the work, and its hollow outwards towards the right hand (No. 3, Plate III.). The rest is still to remain parallel to the Lathe bed, as in turning the outer surface. Now, keeping the back or bevel as before, bring the point or middle of the edge to the centre of the work, and cause it to penetrate slightly, by moving the right hand, which holds its handle, a little outwards. This will cut a little conical recess. Repeat this, pushing the gouge onwards each time beyond the centre, and also gradually raising the point and rolling the tool over, till, at what may be called the top of the cut, it lies almost face downwards. It is difficult to describe the action, but the shaving should curl out rapidly in little coils, leaving a smooth surface. For deep cuts, it may be necessary to turn the rest round somewhat, so as to bring its tee more across the face of the work (as shown in No. 1, Plate III.), but not entirely so. This is a curious way of using a gouge, causing it to cut *beyond the centre* instead of on the near side; but nothing can exceed the ease with which it will cut when so used, and the hollow can be extended and deepened, within certain limits, with great rapidity: a few minutes will suffice for an egg-cup. It is worth while to risk spoiling one such

article, by turning round the rest to stand across the work—(it is so placed for hard-wood turning)—and then to lay the gouge on its back, and try to hollow out the egg-cup by turning the near side instead of the further one. Probably, any novice would try thus if left to himself. The tool held still will bore a hole of its own size, just as a quill bit would do, if used in a carpenter's brace. But as soon as the attempt is made to enlarge it, the gouge will catch in. Even here, however, something may be done by remembering the rule to keep the back, or bevel, against the surface to be cut. By this, however, it is evident that the tool must be on its side, and not on its back; the hollow being towards the centre, and the cut proceeding from without inwards. There will be no "catch in" in this case, and the hollowing may often be carried forward thus. But as long as the tool can be got to work in the other manner, cutting from the bottom of the recess outwards, this will be found to produce the better work. The egg-cup is so comparatively shallow, and of such small size, that it may be begun and finished thus; but for larger work both methods may be combined—now working from the centre outwards, and now the other way. In fact, a turner can use his tools in all sorts of ways with equal facility, but a learner should not take such liberties.

It may readily be seen that it will be impossible to get a flat bottom with a sharply-defined angle in this way with the gouge; and, therefore, when such is necessary, the last touch must be given by a chisel, held quite flat on the rest. A common carpenter's chisel will answer very well for this. A dozen egg-cups will enable a learner to manage the gouge only, as they do not require to be finished inside to a flat surface; nor, indeed, is it necessary with a match-vase or spill-pot. But it will soon be discovered that a gouge cannot be used as described for deeper work, as the limit of its cutting power is soon reached. For deep work in soft wood, tools called hook tools are used in the trade, but are so difficult to manage as to be seldom found in amateurs' workshops. Round-end tools, chisels, and gouges are therefore used, and the surface finished with inside tools similar to those for hard wood, the finish being given by glass-paper. These

tools will be fully described in treating of hard-wood turning.

BOXES.—These will come next in order as needing a little more skill than egg-cup turning, as the cover has to be fitted nicely. The first thing is to cut off a bit of wood long enough for box and cover, with something extra to allow for the length of the taper screw and for waste—say, 4in. for a 3in. box or 2½in. one. The wood can be held in a cup chuck instead of the taper screw, if preferred; and in that case it is merely trimmed roughly to a cylindrical form, and driven into the chuck about ¼in. To save the mandrel from violence, it may be thus driven in while the chuck stands on the bench, or on a block of wood, although it will most frequently be done after screwing the chuck on the mandrel. In this case, there is no need for heavy blows, which tend to damage the tail pin or mandrel; but a few steady taps from a light mallet will suffice if the wood fits fairly well. The learner will, however, find it necessary to drive the wood in more deeply than an adept, as he is more likely to have a hitch in of the tool, and in that way to throw the wood out of the chuck altogether. Supposing it to be secure, the first thing is to reduce it to a cylinder by gouge and chisel, and for this the back centre may be brought up to steady it. When, however, it is once shaped, the loose poppet is to be slid back, as before, out of the way. The usual way is to hollow out the extreme end for the cover, then to cut this off, and, from what remains in the chuck, to hollow out the box; and this is the best plan, as it enables the turner to try on the cover again and again, until a satisfactory fit results. Following this plan, the cover is to be faced off true with the chisel held quite flat on the rest; or, if it is very rough, the gouge is first used, laid on its back and held horizontally, the rest being, of course, turned round so as to bring the tee across the face of the work. Then, as soon as the surface is made flat, begin as for the egg-cup, only keep the hollow very shallow; and then, with the chisel held flat, square the recess thus made, and especially take care to make the side quite perpendicular to the bottom, and not in the least conical, for on this will the exact fit of the cover chiefly depend—and a

well-fitted cover is a credit to the learner. Light cuts will have to be taken at last, using the more pointed corner of the turning chisel to get into the angle and to finish smoothly the inside. When the cover is done, a tool called a parting tool is generally used to cut it off. It is like a very narrow chisel, with (when meant for soft wood) a groove or notch in it. But this tool is not absolutely necessary. A tenon saw, held against the wood as it revolves, will soon cut it off; or the chisel set on edge and made gradually to cut a deeper and deeper notch till the piece is severed, or used to cut a deep notch, to be followed by the saw. After this, the end of the work is again faced off truly, and the rebate is cut, with the chisel, upon which the cover of a box always rests; but, in this case, it is left a little too large at the present stage, as it will be cut down again, and accurately finished after the box itself has been hollowed out. This is the work to be now taken in hand.

In either case the top of the box will be neither smooth nor level, but that will be rectified presently. The box itself must now be hollowed out as described, using the gouge as far as possible, but finishing with the chisel. Care must be taken not to go too deep, or in cutting it off when done there will not be found enough stuff left for the bottom, and it will come off in the form of a ring. After it is sufficiently hollowed out, and the inside is levelled and smoothed, the rebate or flange is finished till the cover will just go on tightly. This part must be left exactly cylindrical. It will be generally conical in the hands of a beginner, either small at top or at bottom of the rebate. The cover must slide on and fit all the way, and not go on easy at first and then fit tightly when pressed quite down. This accuracy will be found difficult, but patience must be exercised, and a very light cut taken each time after trying on the cover. The latter should fit so well that its junction with the box is only visible as a thin line. When the fit is perfect, the cover is left on, the rest put across the bed, and with the chisel laid flat upon it, the outside of the cover is turned to a dead level. With the sharp angle of the tool a few circles are often cut, by way of ornamentation, both on the top of

the cover and also on the side of the box itself. The work now has to be cut off, just as the cover was severed. If a parting tool is used, it is placed exactly upright on its edge and steadily advanced, keeping it horizontal, or with the point only very slightly raised. This point must not be allowed to get, at any time, below the level of the centres, or the tool will be drawn in. Also, although its edge is so broad as to clear itself as it enters, it is safer to make it cut now a little on this side and now on that, so as slightly to widen its own groove as the cut is made. All danger of a catch in is thus avoided, and the tool can be advanced quite to the centre, when the box will fall off. With care and a little practice the bottom of the box should be quite level, but it will probably be found necessary to re-mount it on a wooden chuck, turned to fit inside it, so as to get at the bottom of the box for a final cut, to finish it. A very common fault to be guarded against is getting the bottom of the box rounded, so as not to stand well when placed on the table. It may be made very slightly hollow, which will not matter, but every care must be taken that the centre shall not project in the least. Of course, the outside of a box need not be of pill-box uniformity, but can be moulded to any shape, and, if so intended to be formed, the sides should be left rather thick when it is hollowed out.

In order to insure the perpendicularity of the rebate of the box, an instrument is used called a turner's square, but it is easy to cut a rectangular notch in a bit of card or tin, and to test with this as shown in No. 6, Plate III. The long edge of the card is to be placed in contact with the top, and the short edge of the notch will test the accuracy of the inside, which it should exactly coincide with. The inside of the cover may be tested with a similar card. These little home-made contrivances are very useful, cost nothing, and can be made in a few minutes. A similar gauge is useful where a number of articles are to be of exactly the same size, either in length or thickness. Cut gauges cannot shift like calipers, which, again, are not practically very easy to use for accurate testing; but such a gauge as that shown, even of card, is of great use, and well worth making.

Suppose, for instance, you wish to make several tool-handles, all of one length and size, with mouldings like No. 1, Plate V. We may make a gauge of its length by two nail-points in a bit of wood (C), and two others a little shorter, which are to mark the highest points of the moulding when the gauge is held against the wood as it revolves after it has been turned to a cylindrical form. Then it can be roughly shaped, and from time to time tested for size by gauge B. This is a far speedier plan than to measure the length by rule or compass and then to use calipers for size, which would have to be set separately to test the hollows and the convex curves.

Carrying on a little further our description of hollow work, we will take that simple article a needle-case or bodkin-case, in which the length very much exceeds the diameter. In this the gouge cannot be used as in larger work, and may advantageously be replaced by an ordinary shell bit or nose bit, such as carpenters use with a brace; or by the twisted or spiral drill used for metal. The latter, held in a tool-handle, answers splendidly, doing its work in a few seconds without undue strain. Drive the bit of wood, as before, into a cup chuck, not of metal but of wood, or wood driven in to plug the metal one and then hollowed out to the necessary size. Turn it with gouge and chisel as before; run the drill in deeply enough to bore the cover, following it up with a narrow chisel or slightly larger drill, and keeping the bore nicely parallel; then cut it off and set it aside for subsequent finish, and go on with the case itself, using the drill, and, if necessary, following it with chisel or with a narrow round-end tool, if in stock, or with a larger bit or drill; only it must be bored out smaller than the cover, to allow of the rabbet on which the latter fits, and which is made long to prevent the cover from dropping off so readily when the case is carried in the pocket. For work of this kind, sycamore will be found very useful if obtainable. Birch, poplar, beech, alder, and many other soft but not splintery woods can also be used; and of those ordinarily found in the country hornbeam is exceedingly useful. Acacia, again, is a nice and also handsome wood, but almost any stuff will do for simple work of this kind.

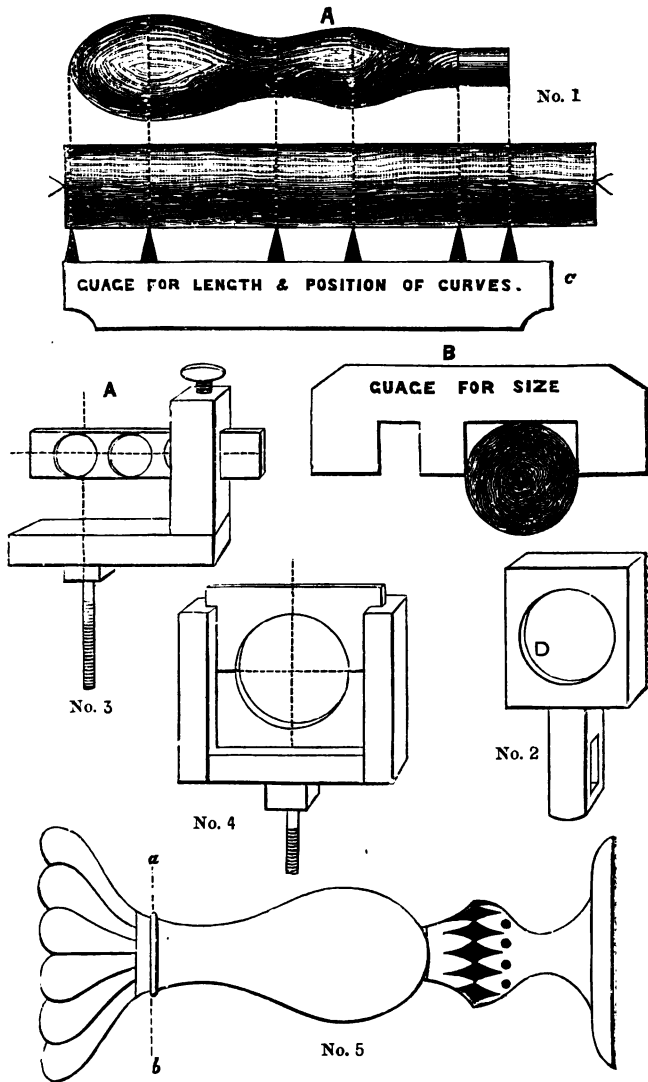

PLATE V.—BORING-COLLARS: USE OF GAUGES.

1901

If the article to be bored is over three or four inches long it will be found difficult to turn and bore it without further support. In such cases, what is known as a cone plate or boring-collar is used, or very frequently a temporary substitute made of wood. The cone plate properly so called consists of a short poppet from which projects a stout pin secured by a nut at the back. Upon this is fitted a circular metal plate, having near its circumference a ring of conical holes of gradually increasing size, the centre of any one of which is exactly level with the Lathe centres when such hole is at its highest point. The largest part of the cone stands towards the mandrel, and that hole is selected which will allow the end of the work to rest in the cone without passing through it. Thus supported, the extreme end of such work as a needle-case or deep spill-pot can be got at by a boring tool, and, being thus supported, there is no danger that the work will be thrown out of centre or forced out of its chuck. In such a cone plate the largest hole cannot be over 2in. diameter or thereabout, and is, in fact, seldom even so large. It is, therefore, hardly suitable for the general work of a wood-turner, and may be advantageously replaced by one of the home-made contrivances on Plate V. The first is merely a piece of plankwood cut with a tenon to fit between the bearers or bed of the Lathe, and fastened with a wedge or bolt—generally the former. The hole is preferably cut in the Lathe, which alone enables a nice cone to be formed, but it is often sawn out and bevelled by the chisel, followed by a cabinet rasp and file. Of course, it is only suited for one size of work; but a wood-turner will arrange his work accordingly, as he generally makes a large number of articles alike, turning them in sets—a dozen or two of one size, and then a dozen of another; so that with two or three such boring-collars he can get along very well. No. 2 D will sufficiently explain this simple arrangement. No. 3 represents another plan in which a mortice in an upright part of a specially made base carries horizontal plates of wood, with one, two, or more conical holes in it. A wooden thumbscrew or plain wedge secures the plate in position. The bottom part stands on the bed,

and a plain bolt and nut will secure it. It is better made with a tenon piece screwed on underneath to fit between the bearers as before. A still more complete and stiffer arrangement is made by having a frame put together firmly with dovetails, in a groove in which the boards containing the conical holes slide. These are also for convenience sawn across, which renders it easier to adjust them to the work. This, shown at No. 4, is far better worth making, because it can often be fitted over a neck or smaller part of the work if not large enough in the bore to fit the larger diameter. It might, for instance, grasp the vase (No. 5, as shown at the narrow part, *a*, *b*), and it will hold it quite steadily for hollowing out.

It would probably not be supposed that a simple cylinder without any mouldings is far more difficult to turn than such a piece as a baluster or pillaret, but so it is. Nevertheless, a wood-turner, skilled in the use of gouge and chisel, will accomplish it readily enough by hand, where an amateur would fall back on the slide rest to give the rectilinear motion to the tool. In short, a slide rest, or other mechanical appliance, is not to be found in a wood-turner's shop, and is, indeed, quite unnecessary, except for ornamental work in hard wood and ivory, and for turning metal.

To turn a cylinder, the top of the rest should be level, and if notched it should be corrected with a file, so that a gouge or chisel may slide along it with regularity. After the wood has been roughened down almost to size, the gouge should be carried along quietly and steadily, using its side more than its point, and the chisel must follow; great care being taken to keep it at the same angle throughout, that it may not cut more deeply in one place than in another. A series of light cuts with a good quick speed will best insure success. Quick speed is absolutely essential in turning soft wood—it can hardly be too high—but for hard wood it may be more moderate. But in all these mechanical arts we can only say how the tool is to be held and used: we cannot give skill, which nothing but long and careful practice can afford. It is no use for a learner to think he will turn out good work; he will turn one handle or egg-cup while a good workman

will turn a couple of dozen, and his work will also be inferior. But that workman also was once a learner, and his acquired skill is likewise attainable by perseverance. In nothing is this so true as in turning soft wood, because in this you are not able to use those mechanical contrivances which insure correct results. With ivory and hard wood, you may turn and hollow out and decorate a true sphere almost with hands in pockets, leaving the Lathe and tool to do their own work. Hence it is that an amateur spends so much and finds turning so costly. He does very little, and that little is expensive. He then goes, perhaps, into such a shop as Oetzmann's or Maple's, and sees overmantels, and cabinets, and tables, and all kinds of serviceable articles of great beauty, to which the Lathe has contributed very largely; and he may rest assured that neither slide rest nor any costly apparatus has been used in the manufacture: only plain Lathes, two or three tools, and a good deal of labour and skill. Turning should cost very little—such turning as the generality of amateurs ought to take up—and Lathes are getting cheaper than ever, so that even a labourer, with spare time upon his hands, might profitably employ himself in turning, and add a few pounds to the family purse. Where most amateurs fail is in the matter of patience. In some of the articles, for instance, just alluded to, there are, perhaps, fifty to a hundred little turned pillarets, all exactly alike, and about 2in. in length. To an amateur, this would be a tedious job; but a professional will go on, day after day, and all day long, till the Lathe bed is piled with pillarets; and although the gouge and chisel alone are used, and, probably no measurements are taken, yet all are alike in size and pattern.

CHAPTER III.

TURNING BOXWOOD AND FOREIGN HARD WOOD.

THE tools used for the above work differ considerably from those used for soft wood, which they will not, in fact, cut so as to produce a good surface. The gouge and chisel are, however, still used, and, generally speaking, the former is the roughing-down tool. But hard wood admits of much finer beads and mouldings, and will take a higher polish, and it can be covered with a network of fine tracery and delicate carving, which is quite impossible in the case of soft wood. Screws, moreover, can be cut upon this material, either coarse or fine, which can only be managed with difficulty on soft wood, on which also, if cut, the pitch must be coarse. All hard-wood tools lie flat on the rest, and are, in consequence, easy to use, and whatever the profile of the edge may be, it is, of necessity repeated on the work, if the tool is held still, such profile being, of course, reversed. The tools are of various shapes for cutting to right and left, turning hollows, and beads and mouldings. The more general ones are illustrated here, so far as their cutting edges are concerned.

A, Plate VI., the flat tool, is sharpened on both sides as well as on the edge; B, C, bevel tools, are sharpened in the same way (the bevels of all the tools shown being supposed to be underneath); D, similarly sharpened, is the round tool, used for turning hollows, and sometimes for roughing-down hard wood and ivory, instead of the gouge; E, the bead tool, is made of all widths for turning beads and small spheres, like those on the head of a chess pawn; F is sharpened only on the

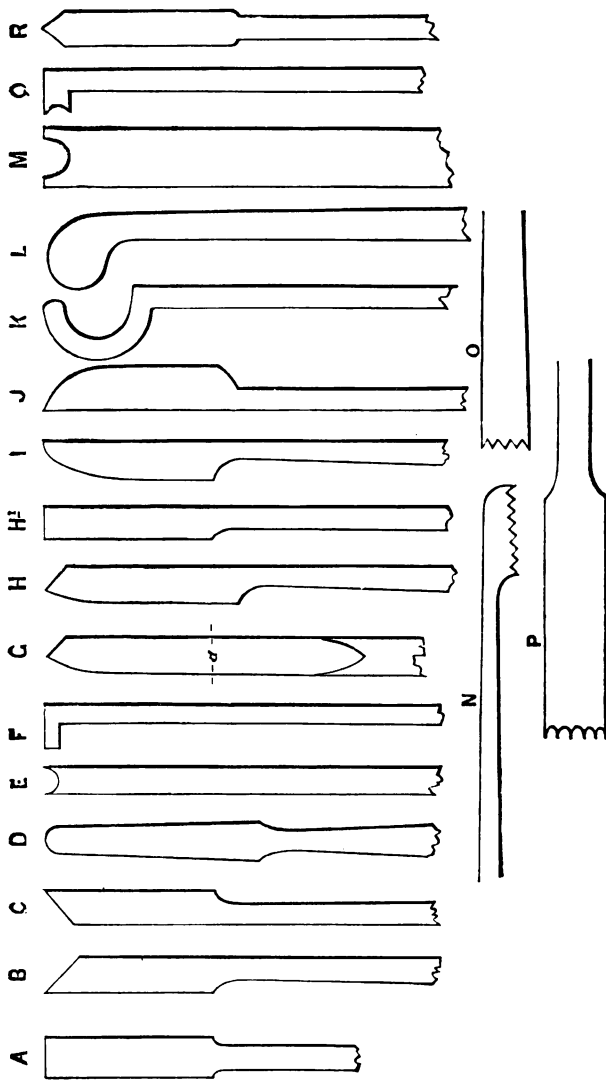

PLATE VI.—TOOLS FOR HARD WOOD AND IVORY.

end of the bent part—it is an inside parting tool, and is made in sets with longer or shorter bent part; G is a side view of an ordinary parting tool—it cuts at the extreme end, and is ground thinner downwards to about A on each side, so as to cut itself clear; H, I, J, are inside, or right and left, tools, cutting on the ends and sides for hollowing out work—they vary in shape as shown; K, is ground all round the outside of the curve, and is used to hollow out bulging or spherical work, like a humming-top—so also is L; M is a bead and astragal, turning a bead with flats on each side; Q is a ring tool—for instance, in turning a curtain ring on wood, E would round it on the outside, and Q on the inner face: all such tools are made of various sizes, and can be had in complete sets; R is a point tool, for turning angular grooves, and, like D, it is often used for roughing-down work; P is a reeding tool, and is practically a row of small beading tools; N, O, are a pair of chasing tools, for cutting outside and inside screws—they are made of various pitches, coarse and fine. The average price of these tools is 1s. 6d. Screw tools vary in price, according to pitch. It is not easy to determine how many to buy, but perhaps three different sizes of D, E, F, and Q, will do for a start, as these can be added to as may prove necessary, and the parcel post now brings all such tools within easy reach of country customers. A slight sketch of the tool required, with size needed, will enable a tool-dealer to supply it. Handles are from one penny each and upwards, and for these beech is preferable to hard wood.

The hard-wood cylinder can be turned wholly with the gouge and chisel, if the latter lies flat on the rest, with the leading angle kept clear, so as not to mark it. But a chisel thus held is so quickly blunted, that the flat tool, which is thicker, and ground with a shorter bevel, is for this purpose superior to it. The leading angle in this case, also, is kept clear. The cylinder must, of course, be first reduced to nearly the required size by the gouge or round tool, or both, leaving the flat tool as little work as possible. With some woods, a very thin tool for the final touches proves the best, and this is held as a mere scraping tool slightly under-

hand—that is, the edge depressed below the level of centres, instead of being applied horizontally. The ends may be trimmed by the parting tool if anything has to be cut off, and finished by a side tool or point tool held at the required angle. All is easier than the manipulation of the soft-wood tools. Hollow work is commenced by drilling a hole with either a twist drill or nose bit, held in a tool handle, or with a round tool, and enlarging it with the latter, or with one of the bevel or inside tools; and if the recess is to be flat at bottom, like that of a box, the flat tool will level it accurately, and with ease.

Bowls and tazzas, egg-cups, vases, &c., are worked also with any of the round end or other suitable tools, held flat on the rest and swept round the curve. The last cuts have to be made slowly and lightly, taking the whole surface, if possible, without stopping, so as to prevent any lines or tool-marks remaining visible.

In turning beads and mouldings, it is almost necessary economy to spare the beautifully made tools by which this kind of work is done. The tools are easily damaged, as the points are fine, and in the smaller sizes the tools are necessarily slender. Hence, it is usual to reduce the parts just as much as possible with point tool, chisel, or bevel tools, and with these to bring the bead or moulding to its approximate size and shape. Then the beading tool has but to clear away the irregularities and finish the bead to a perfect curve. In the use of the above-named tools, the rest is placed just below the level of centres, so as to allow for the thickness of the tool itself. Although, however, the latter is, as a rule, held level and horizontal, it is sometimes tilted up a little in finishing off a surface. All such variations of position must be decided at the time, and their expediency or otherwise will only appear after some amount of practice. Much depends upon the wood, of which some specimens are far more troublesome than others to bring to a good surface. The maximum of such trouble I have found to accrue in the case of a bit of canary wood turned plank-way and cut into a bowl.

With the harder and more costly woods, the highest

perfection of workmanship should always be aimed at, and this mainly consists of sharply defined curves and cleanly cut surfaces, bold and neatly cut mouldings, of which the contour or profile can be plainly seen. Glass-paper tends to obliterate angles, and, if necessary, it must be very carefully kept from attacking acute edges; but if these are damaged by its use, they must be renovated by a fresh touch of the tool. In this sharp, clear definition of outline lies all the difference between good and bad work. It may also be remarked here that although glass-paper is sometimes absolutely necessary to cut down fibres which cannot be cleanly cut by the tool, it will not hide bad cutting. If, for instance, the inside of a bowl, instead of presenting to the eye one uniform, curved surface, shows a series of flat rings when closely examined, the paper will not obliterate these, and they should be honestly looked for in a good light, and not shirked under the impression that polish or varnish will ultimately conceal them. Instead of doing so, it will render them painfully conspicuous; and with those who know what good work is, these common defects will at once condemn the workman. Moreover, he himself, being cognizant of such defects, will feel no pleasure in his own work. Therefore, although we are of course addressing learners who cannot be expected to become suddenly proficient in an art requiring the skill obtained by long practice, it has seemed better to point out such defects and errors as they are most likely to fall into in their early essays, that they may know what to strive after, and what to avoid, and, so far as possible, *how* to avoid. In this very matter of bowls and cup-shaped hollows, it will be found easier to work with a curved tool of a size proportioned to that which it is proposed to form; as a broad tool such as K or L, is more likely to produce a hollow free from flat bands and irregularities than a smaller tool with round end like that illustrated at D.

TURNING THE PLANKWAY OF THE GRAIN.—This has to be frequently done both with soft and hard wood, as it often happens that it is not possible in any other way to get stuff wide enough for the intended purpose. There is no great

difficulty in working this: even with soft wood the gouge and chisel are used flat upon the rest, light cuts being taken generally from the centre outwards; but for final cuts the tool must be keen. The part which it is most difficult to cut smoothly, is just where the fibres begin to crop out endwise. There will be two spots in a circular disc, where this will be the case, and sometimes they give a great deal of trouble, and need alternate cutting and papering to lay them down smoothly. The harder woods seldom present this difficulty. It would, of course, be a wasteful mode of work to turn such an article as a large bowl or tazza, with stem and stand, out of a piece large enough for the bowl itself, and the latter would be turned separately, perhaps out of a piece sawn plankway, and the stem out of a smaller piece; the stand also probably out of a third. This building-up of work is of constant occurrence, the several pieces being tenoned together, or cut with screws, which is the better plan where the workman is skilful enough to manage it.

The pins or tenons are turned at the ends of pedestals or stems, and the other pieces are drilled in the Lathe, to insure centrality and squareness to the surfaces. Glue or other cement is then used to unite them.

CUTTING SCREWS IN WOOD BY THE HAND CHASER.—This somewhat difficult art is well worth all the trouble that it needs to acquire it. As soon as it is gained, it renders the work more independent of all costly apparatus used to render the process easy to such as cannot succeed with hand tools alone, and the screw can be made in a shorter time than it takes to set up even the simplest of such apparatus; but it would be a mistake to suppose the art in question easy of acquirement, and it needs constant practice to keep up the knack of using the chaser.

The directions given by most of our leading authorities are as follows: "Having turned smooth and true the cylinder upon which the screw is to be traced, round off the edge or arris so that it shall not catch into the teeth at starting, and check the traverse of the tool. The rest is placed very near the work, and must have its edge filed smooth and level if it is at all notched from other work. The tool is to

be held by its handle in the right hand, and its blade between the first finger and thumb, so as to cushion it somewhat, and allow it barely to lie on the rest. Then the Lathe is to be set in easy motion, and after a trial or two, without actually touching the work, just to get the swing of it, a steady, decisive cut is to be attempted, traversing the tool without nervousness or hesitation." Exactly so; but, unless the workman is already an adept, the chances are sadly against his hitting off the thread; and, knowing this, he will be as nervous as a skater making his first essay on the ice. Yet there is no royal road to screw-cutting, and the above directions are as good as any. The best way is to cut threads outside chucks, and any odd bits of boxwood, on all occasions: go at it and keep at it, and the skill will not long be wanting.

The inside thread has also to be struck haphazard, only the movement of the tool is now straight forward into the hole. Many use for this purpose an arm rest, which is a ng-handled, flat bar of iron, about $\frac{1}{2}$ in. wide, tapering down to about $\frac{1}{4}$ in. at the extremity. The end is turned up $\frac{1}{4}$ in., and the chaser rests on the end just behind this hook. The T of the rest is now retained in its usual position parallel to the Lathe bed, and the arm rest is held under the left armpit, with the blade of it across the rest. This places the shank and hook at right angles, or nearly so, across the face of the hollowed work, and the tool is laid on it, instead of having to turn round the T of the rest itself. The hands grasp the end of the arm rest as well as the tool, so that the two move as one. A great deal of inside work, besides screw-cutting, is done with this contrivance, as it prevents having to shift round the T of the rest. Inside screws are easier to cut with its aid, as it moves on the T as on a fulcrum, and gives to the tool an easy swing, as if it moved on a ball-and-socket joint. Each cut of the chaser, especially at the commencement, must be very light, and it must carry itself along by the thread first traced, and not be driven in the least until the thread is well and deeply cut.

The great difficulty will be found with the coarse pitches: the finer, from 16 to 24, are easier than from 8 to 16—the traverse of the latter is necessarily so much faster

and more difficult to hit off, as regards speed. Except for chucks and large boxwood cases, it is not often that the coarse pitches will be needed, and 12 to 24 will amply suffice for general purposes. Holtzapffel, in his valuable work, directs that the first stroke of the chaser is to be across the centre of the curve where the sharp angle has been turned off, like Nos. 1 and 2, Plate VII., *a b* showing the first stroke, and *cd* the second. Thus the screw is gradually worked round to the cylindrical part. The traverse is, of course, from right to left, and from the edge to the interior of hollow work. Personally, I have found it quite as easy to begin at once upon the end of the cylindrical part; but it is, I suppose, a question of habit. I have also generally found it better at the commencement to keep the points clear, and to let the tool touch just below them. This will carry it along sufficiently to let the required speed of traverse be seen, after which the tool may be lowered, so as to bring into action its full cutting powers. But there is no sort of doubt about the difficulty of screw-chasing by hand—a difficulty that is only to be overcome by such constant work as falls to the lot of brass-turners and others who are at work with the chaser every day, and, for the most part, confine the chasing to one or two pitches only, of which they thus soon get the exact pace. By way of encouragement, I may add that a fortnight's apprenticeship often makes a lad at an optician's workshop a fair proficient, provided he is kept to one pitch of thread only, as he soon gets used to traverse the tool at one rate of speed.

Considering, however, that screw-chasing is an acknowledged difficulty, we are not surprised to meet with various suggested contrivances for effecting the work in an automatic manner, especially as this can be done without difficulty in more than one way. Naturally, the first idea is to continue the use of the hand chaser, but to arrange some additional apparatus to insure its accurate traverse. No. 3, Plate VII., will serve to illustrate the principle which, variously modified, has been used for the purpose. There is cut outside the chuck B a screw of the required pitch, or a ferrule with such guide-screw cut on it is slipped on the chuck, and prevented by a feather

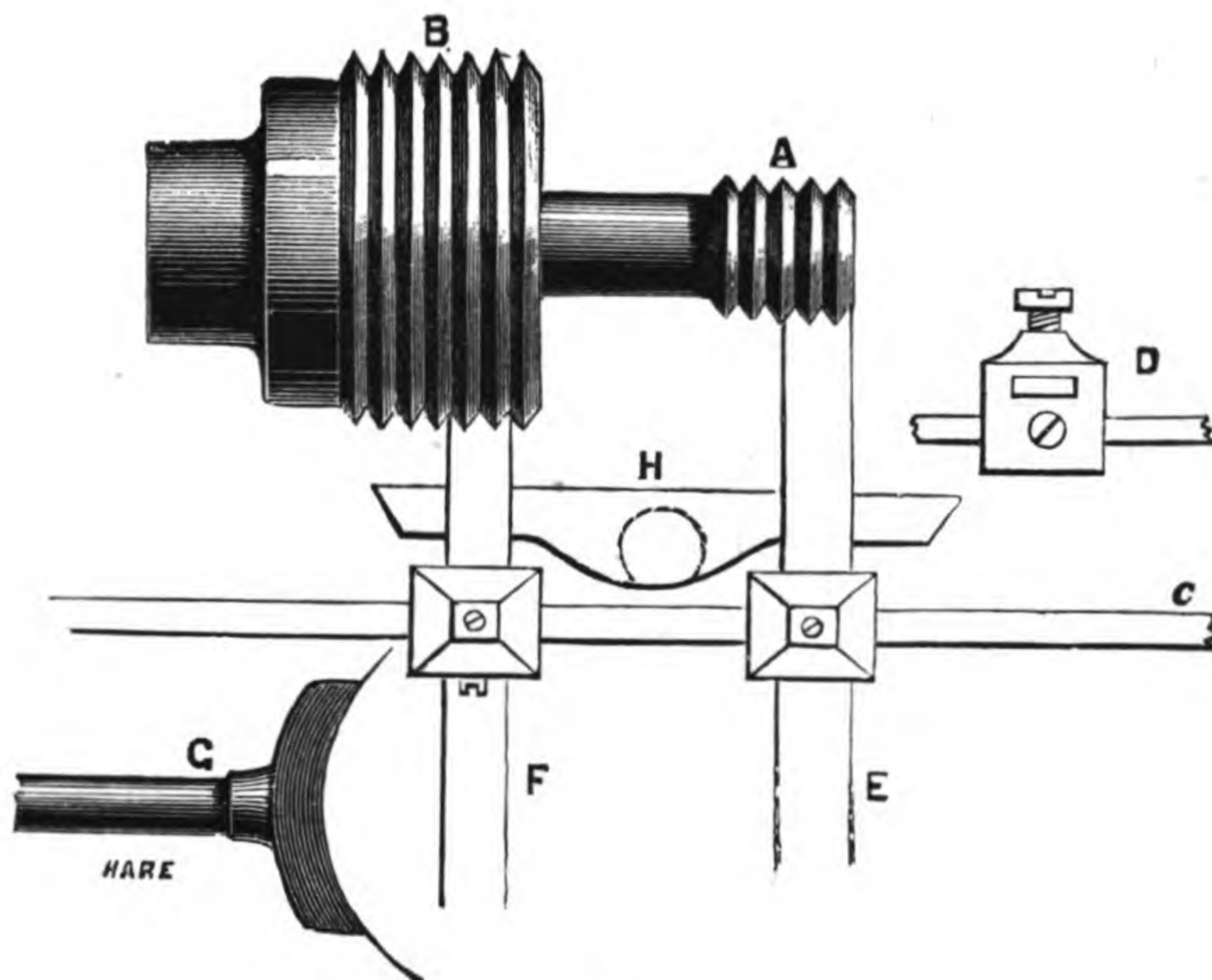
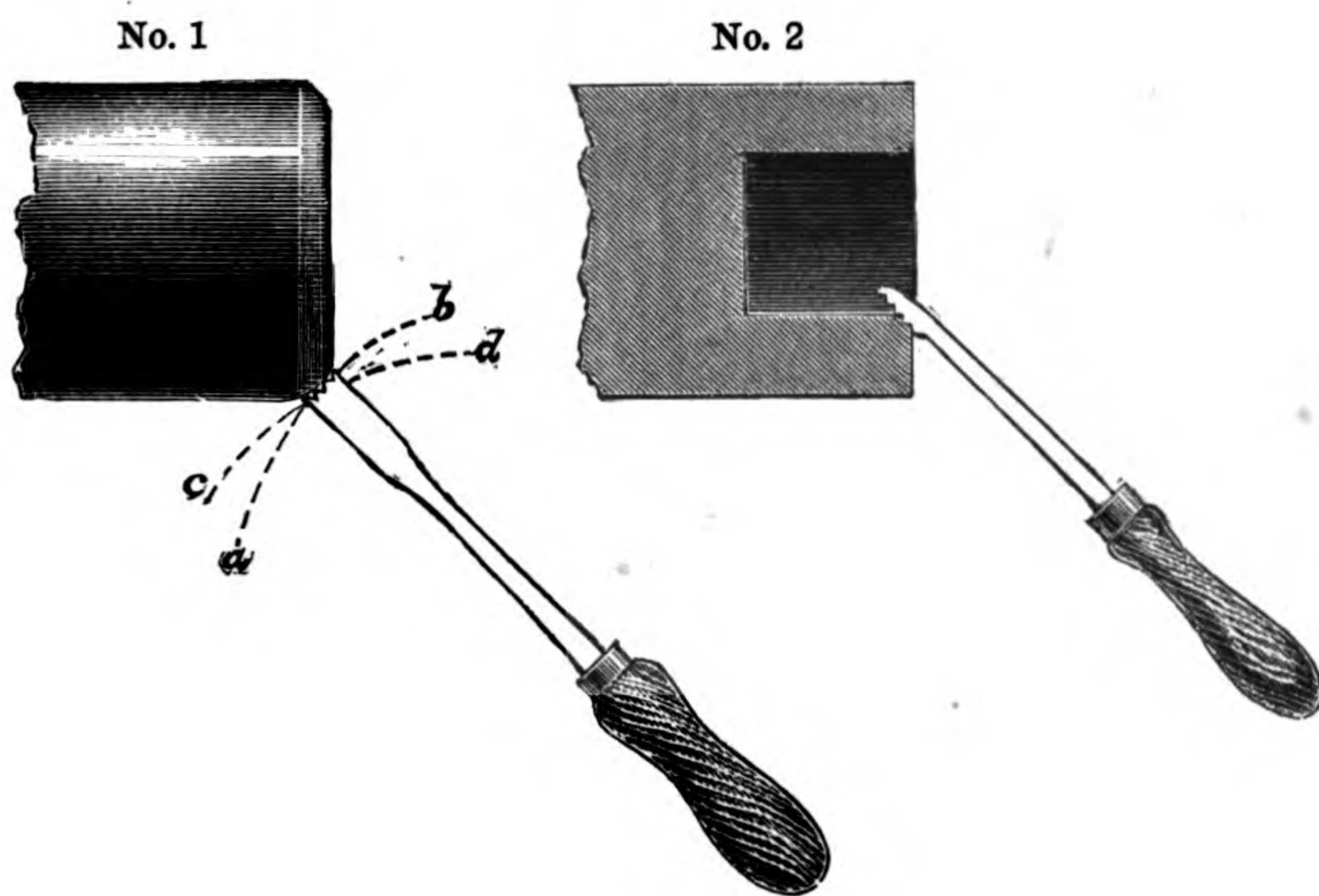

PLATE VII.—SCREW-CHASING APPARATUS.

from revolving upon it. In the latter case, the same chuck will admit of various ferrules, each of different pitch. A is the work upon which a similar screw is required. By means of a bar, C, and a pair of clamps, shown again at D, the chaser, E, is connected with F, a similar chaser, which, however, is not intended to cut, and may be of brass, or even of wood. The tools thus connected at a suitable distance apart, now act as one, and as F is carried along by contact with the screw guide, E, the actual cutting tool will follow at exactly the same rate, tracing a screw on A. Both tools lie upon the rest, H. Theoretically, this is an excellent arrangement, and valuable from its extreme simplicity. In practice, however, it is less satisfactory. The resistance of the cut is apt to throw the guide-chaser out of gear with its ferrule; and, indeed, this chaser needs to embrace a segment of the ferrule, like G, instead of ending merely in one or more points.

Then, again, it is not easy to keep the eye upon both work and guide, especially if they are at all far apart. Hence, without materially altering the original plan, the bar, C, has been made to slide in two suitable sockets, in arms attached to the Lathe—thus steadying the whole arrangement. The sockets, D, are then attached to the bar, C, by screws, but the cutting tool may pass freely through its slot to allow of independent advance. This arrangement has proved to be a perfectly practical one, and is, probably, the best for the purpose, with the sole exception of the traversing mandrel, to be presently described. The supporting arms and sockets need not be in the way, and the bar can be readily unshipped and removed entirely. For inside threads a slightly different arrangement is needed. Suppose E, on the right, to be a plain bar to act as a rest, and the tool to be laid across it, just as it is with the arm rest. If the tool is firmly held, and the bar also gripped, the thread will be cut as before. In practice, this rest arm has a clamp to secure the chaser.

There are several other ways of guiding a tool, but these do not belong here, as they all need a slide rest and gearing by wheels or by cords, and are not to be classed with hand tools and their manipulation. Of all contrivances which admit

the use of hand chasing tools, none equals in simplicity, combined with efficiency, the traversing mandrel of which the old pattern, but without the headstock, is shown in plan in Plate VIII., No. 1. B, B represent in section the collars, which used to be of brass, or even of a softer metal—pewter or type-metal—which were made in two parts, so as to be tightened up when worn. The two ends of the mandrel are cylindrical, that they may be able to slide lengthwise, as well as to revolve in their collars. When used for ordinary turning, a pin—seen on the left-hand collar—or a falling stop entered a groove in the mandrel, preventing longitudinal motion. Upon the mandrel were cut short lengths of screw of various pitches. Only three are shown here, but six or eight were often cut, of which one was usually of the pitch of the mandrel nose, to assist in cutting screws in the wooden chucks.

To cause the traverse a very simple expedient was used. A block of soft but close-grained wood, seen at F, was pressed by a wedge against the selected thread, and the pin or catch in the back collar was removed. As soon as the mandrel was made to revolve, a thread was impressed in the wood block, which thus at once became a stationary nut, or section of a nut; and, as this remained immovable, the mandrel itself was compelled to run forward at the exact rate of the particular screw thread that had been selected. A single point tool, or a chaser of similar pitch, needed only to be held quite still upon the rest, and a screw was cut perfectly identical with that on the mandrel. With this apparatus even a tyro can cut a screw in boxwood or ivory, or other material, and even in soft wood. But, in the latter case, a V tool, as it is called, is used, which is in shape like a narrow strip of writing-paper, folded lengthwise, and sharpened at the end. That for inside work is similar, but cuts at right angles to its length: with these only a single cut is taken, which finishes the screw to its full depth; but with hard wood the chaser is generally allowed to retrace its course two or three times. The old pattern of screw mandrel illustrated is mounted on wooden headstocks, the front and back collars being attached with bolts. They are greatly used at Tunbridge, and abroad,

No. 1

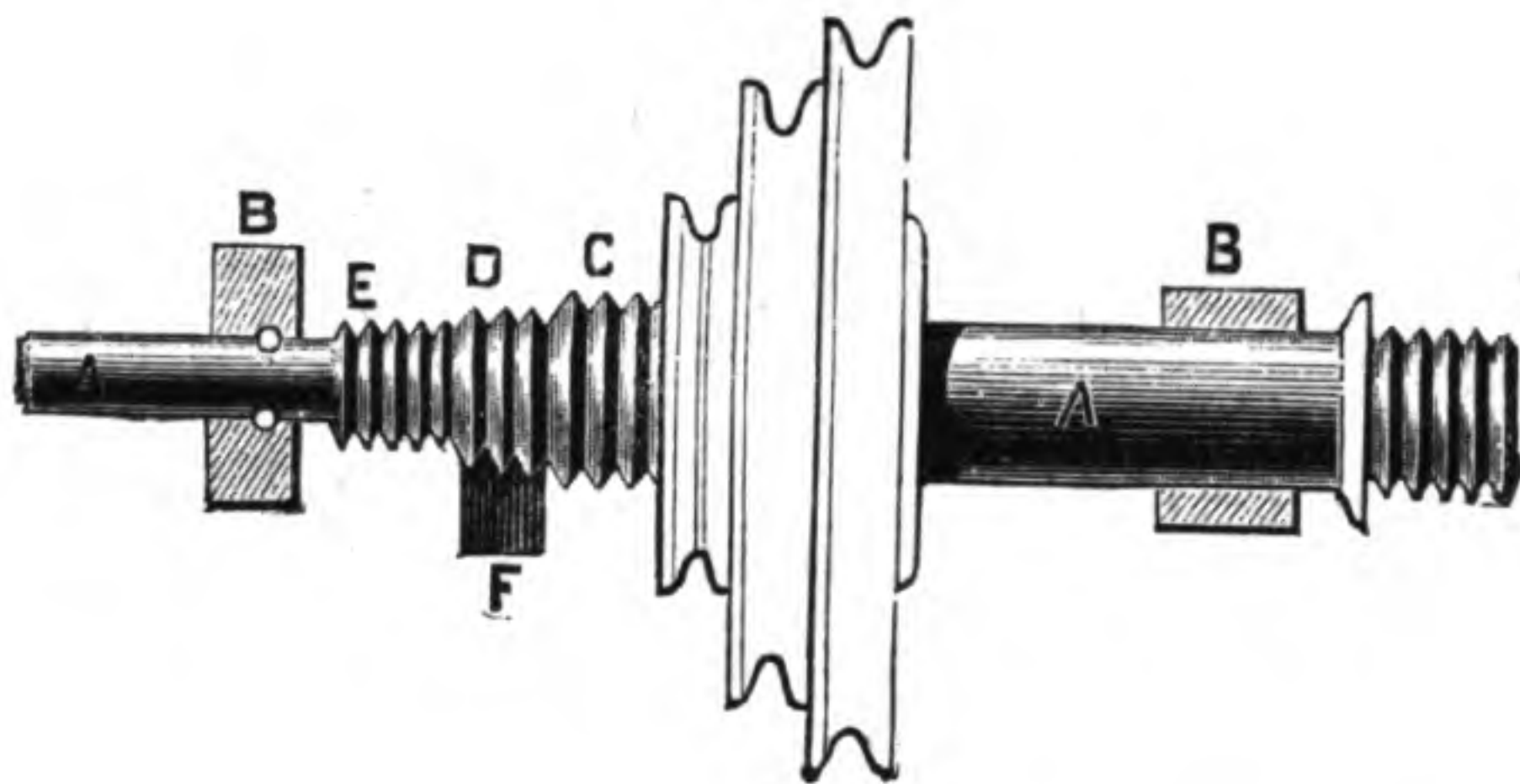

No. 2

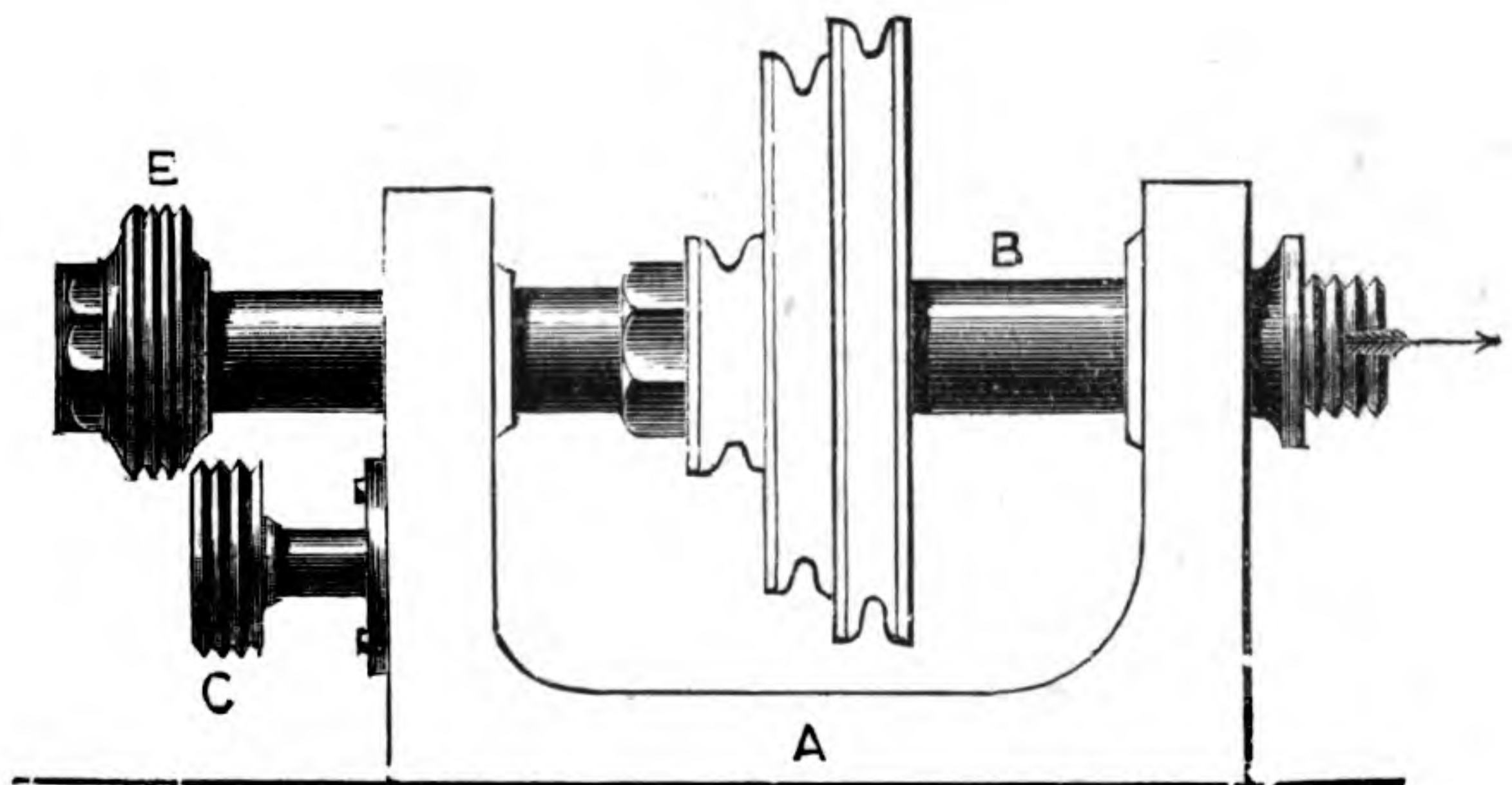
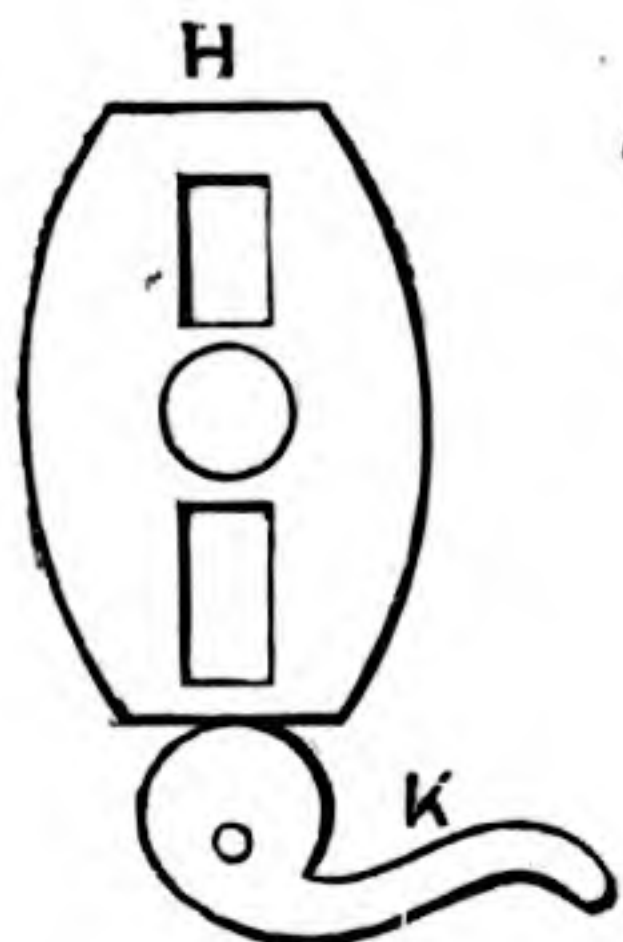
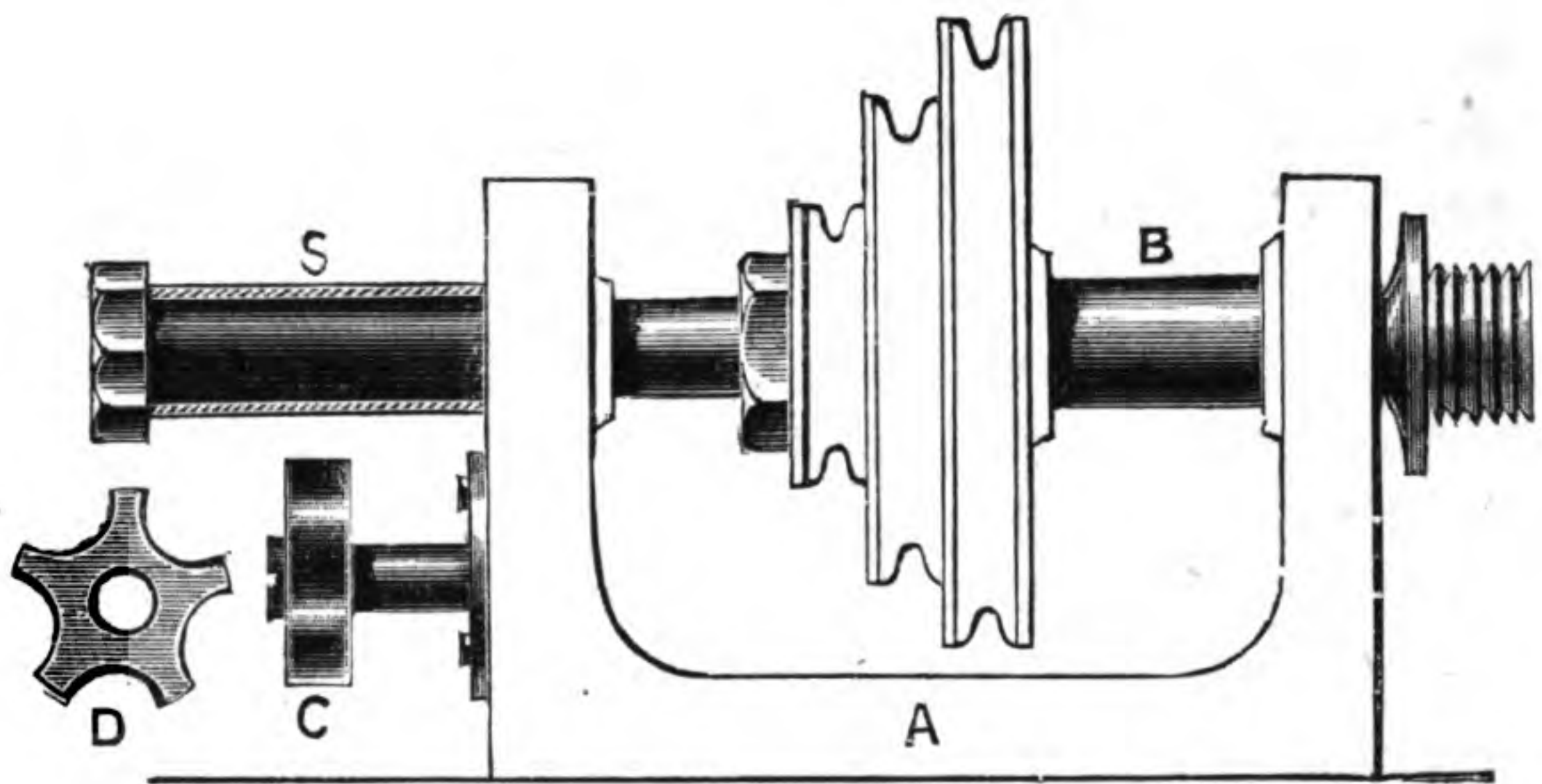

No. 3

PLATE VIII.—THE TRAVERSING MANDREL.



both in Germany and France, but are not now made to any extent in England, having been, in a great measure, displaced by the neater and more expensive form, in which the screws, instead of being cut directly upon the mandrel, are cut upon rings or ferrules of brass or steel, and attached to the back part of the mandrel which projects beyond the collar, and is outside the headstock.

Before explaining in detail this modern arrangement, it may be as well to go a little into the mode of using the traversing mandrel, as this will apply equally well to both forms of it. The work, it will at once be understood, will travel forward towards the right hand; and, therefore, the back poppet cannot be used: it is only for work chucked on the mandrel, that cannot be done without such other support, that this contrivance is available. A screw cannot be cut with it on the end of a long rod. Thus, also, as this traverse will carry the work forward, the rest must be far enough away, when cutting the inside thread, to allow of this forward movement taking place to the full extent required. This must be tested, both for inside and outside work, before the cutting is commenced. Again, when there is, as always is the case with a box, a short tenon with a shoulder, care must be taken to see that the tool will not, at the end of the traverse, come up against this shoulder, which, by causing a sudden shock, would damage the thread; and the same would happen if, in cutting a screw inside the cover of a box, the end of the tool should strike the inside of the top. It is easy to test this before finally setting the tool to its work. The Lathe is also not allowed to get into full motion, the flywheel only taking a half-turn to and fro, which will give, however, several full rotations to the mandrel. The crank must, therefore, not be allowed to go over, or, in all probability, serious damage will occur, as the threads on the guide ferrules will get jammed. The treadle motion is, therefore, kept carefully under control of the foot, and only a gentle to-and-fro swing is given to the crank axle and flywheel.

A beginner generally finds a little difficulty in holding the chasing tool quite still, and is apt to let it be carried along the rest by the advance of the work. An easy way to

prevent this is to drill a hole in the flat-topped rest, and insert a pin on the right of the tool, which will then be kept steadily in its place; or a block of boxwood may be made, with a stem to fit into the socket of the rest, having a groove or channel cut in it for the reception of the chaser, which will be free to move forward into cut, but not to traverse sideways. After a little practice, the difficulty will disappear; but these little aids need never be despised, and may save work, otherwise well turned, from being spoiled. The chief thing is to allow the tool only to take light cuts, so as to present as little resistance as possible to the forward motion of the mandrel.

It is not necessary to finish the thread with the guide-screw in gear, as there is no difficulty after the first cut has been made sufficiently deep to catch fairly the points of the chasing tool. As soon as this is done, it is better to remove the guide, or, at any rate, to throw it out of action, and to finish the thread to its full depth by hand alone. Then, if it is not a good fit, but too tight for its nut or box-cover or other part that is to be attached to it (let it always err on the side of tightness), the chisel can be used, or the flat tool, to take off the tops of the thread, and the chaser can be applied again by hand alone to re-touch and finish the threads again; and this process can be repeated again and again, if necessary, until an accurate fit has been obtained.

In metal-work done with stocks and dies, there is a standard of size for the bore of a nut, to enable it, when tapped, to exactly fit the screw. But in ordinary turned work, in which the traversing mandrel is to be used, a little trying-on of a box-cover is both lawful and very expedient indeed. Suppose the cover to have been just made, and its inside screw cut and finished, the outside of the box tenon must be turned to a diameter equal to that of the inside of the cover, measured to the bottom of the thread cut in it. To measure this is not very easy, because, if done with inside calipers, with points sufficiently fine, you cannot pull them straight out: you may do it with in-and-out calipers if very accurate; but, without pulling them out of the thread, you must, with a second pair of

outside calipers, take the width of the points of the first pair—*i.e.*, of course, the points outside, which are just as wide apart as those buried in the threads; you can then close and remove the latter, and the second pair will gauge the tenon. But it is far more usual to work by guess, trying the screwed cover upon the tenon till it appears to be the required size, but leaving it, if anything, too large. It is then cut with a screw thread, and tried as already explained, and, if necessary, cut down, and the thread renewed as often as may prove necessary until it goes on well. But for boxes and scent-bottle cases, and all work that will be constantly taken apart, do not make too tight a fit. It ends in splitting the cover, or being compelled to use the vice to hold the work while it is being unscrewed; and, although a rub of soap will help the matter as an effective lubricant, it is seldom that the work escapes damage, if not entire destruction. A *tight* fit is not to be called a *good* fit.

The modern screw mandrel (No. 2) is a neater arrangement than the last, but in principle it is exactly the same. A is the poppet, not of wood, but of cast iron; and this is usually japanned black, except in the front face, where it is made bright. Hard steel collars are let into it to receive the cylindrical hardened mandrel (B), which is free to revolve and to slide lengthwise, but is so well fitted as not to have the least atom of side play. Such a mandrel of best quality will wear very many years without running loose in its bearings. The front end has a short conical neck, and the mandrel is put in in that direction. To draw back the conical part into its bearing in the front collar, a sleeve (shown in section at S) is slipped over the projecting part of the mandrel, and secured by a nut and washer at the back. This, which is also hardened at the end, bears against the back collar, and retains the mandrel in its place. This sleeve fits over a short feather or pin, that prevents it from itself rotating upon the mandrel. For ordinary turning, all parts remain in the position indicated. There being no tail pin to take up the end thrust in such operations as drilling and boring, this comes entirely upon the front cone. These Lathes are not, therefore, well suited for such work, and are mostly purchased

by those who practise ornamental turning, in which there is no heavy or detrimental work to be done. The conical neck is, of course, so proportioned that it shall not jamb by the ordinary thrust of the back poppet, when this is in use for turning cylindrical work of such length as to need its support. When it is desired to cut a screw, the box or other article is carefully turned to a form truly cylindrical, the rebate being also accurately rectangular.

The rest is then placed about $\frac{1}{4}$ in. from the work, and (as explained) well towards the right, in which direction the traverse will take place. If the stem of the rest is placed about where the traverse will begin, the hand grasping it and the tool together will be better able to prevent the latter from being carried sideways when the cutting action begins. The sleeve (S) is now removed by unscrewing the nut which holds it, and a ferrule, having been selected, is slipped on in its place. The nut is again attached to secure it (see No. 3). The disc (D C) is turned round by the fingers, to bring uppermost the half-nut matching the ferrule, and then it is raised until it just gears with one or two threads; a drop or two of oil is added, and the mandrel run forward without applying the tool to the work, in order to see that everything works easily and smoothly, as it should.

If all appears satisfactory, the treadle is now used to give half-revolutions to the crank, and the tool is gently but firmly advanced to the work, upon which it will trace an accurate thread, which can be deepened with or without the traversing apparatus, as already stated. In the drawing, the stud, upon which the segment-plate or scalloped disc is mounted, is represented as attached to the headstock by two screws. The plate (seen at H, Plate VIII.), with two slots in it, permits of being slid up and down upon these screws, by which it may also be held when in position. It may be raised by hand, but it is more convenient to do this by an eccentric, like K.



CHAPTER IV.

METAL-TURNING WITH HAND TOOLS.

THE principle of the cutting action of all tools is the same. They are thin wedges, which force apart the substance of the material upon which they are engaged; they must, consequently, be harder than such substance, and their edges must be as thin as is consistent with the necessary strength. They must also be held in the position most favourable for the operation.

The resistance which has to be overcome by a cutting tool is twofold: first, the hardness of the material which it has to penetrate; and secondly, the rigidity of the shaving which has to be separated, and which must be capable of curling away as it is cut, and escaping from the upper surface of the tool. If too deep a cut is attempted, so that the shaving is too thick to curl away and escape, it holds the tool fast by compression, and breaks its edge; or, if strong enough to resist breakage, the machine driving such tool is brought to a standstill. Metal, offering considerably greater resistance than wood, needs tools with stronger edges; and as their strength is, on the other hand, limited by the necessity of keenness, they require careful adjustment in order to enable comparatively keen edges to do their work without breaking. The shaving must be thin enough not to endanger such fracture, and its thinness or the contrary depends upon the angle at which the tool meets the work.

Again, it is essential that metal-turning tools be well supported, owing to the strain which comes upon them in

the act of cutting. They cannot be held like the chisel at A B (Plate IX.), because the direction of the strain is as nearly as possible in a line with the tool, which, in the case of metal-turning, would slip down towards the hand. Hence, a rest with flat top, like C, No. 2, has to be substituted, which supports entirely the heel of the bent tool, such as is used for iron, and of which the edge, thin and sharp, is also supported by the metal below it, the strain tending to fracture it being reduced to a minimum. An exception in the need of a flat-top rest, occurs, however, in the case of the graver, which is seen at E, No. 3. This tool would be placed as shown, ready to cut a shaving from the bar of metal, commencing at the end. It is evident that as the strain is downwards, this tool is perfectly supported by the T of the ordinary rest. The tools for iron always have sharp edges, which are not suitable for those intended for brass and gun-metal. The tool H, No. 5, called a triangular tool, and which, having cutting angles of 60deg., can be made of old saw files ground till the teeth are removed, is the usual tool for inside work; and for turning the ends of cylinders and sides of collars and flanges it is a splendid tool, cutting with great freedom. There is not much light work that cannot be done with this tool and the graver alone, but for heavier cuts the one shown at D of No. 1 is more serviceable. This is made in two forms, O, P, one for smoothing, the other for roughing. The heel is often drawn out a little, to grip the rest more firmly. G is, as a brass-turning tool, what H is for iron and steel. The edges are rectangular, as a sharp edge proves too eager for yellow metal and is apt to catch in and spoil the work. L, No. 6, is a side view, for instance, of such tools as J and K, having an angle of 80deg. or thereabout, which is sharp enough for most purposes. The tools J, K, are almost counterparts of those for hard wood, which, indeed, are not unfrequently pressed into service in default of others. The round-end is the best of all for roughing-down brass. At P is shown a rest which has been greatly used by turners of brass, but is not so often seen now that slide rests have become so general: a few years ago, owing to the cost, they were the exception. The pins are inserted in a flat-top rest,

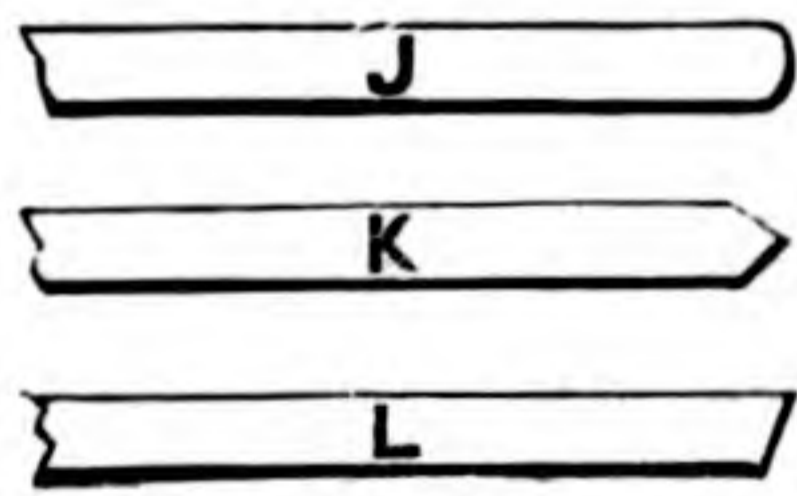
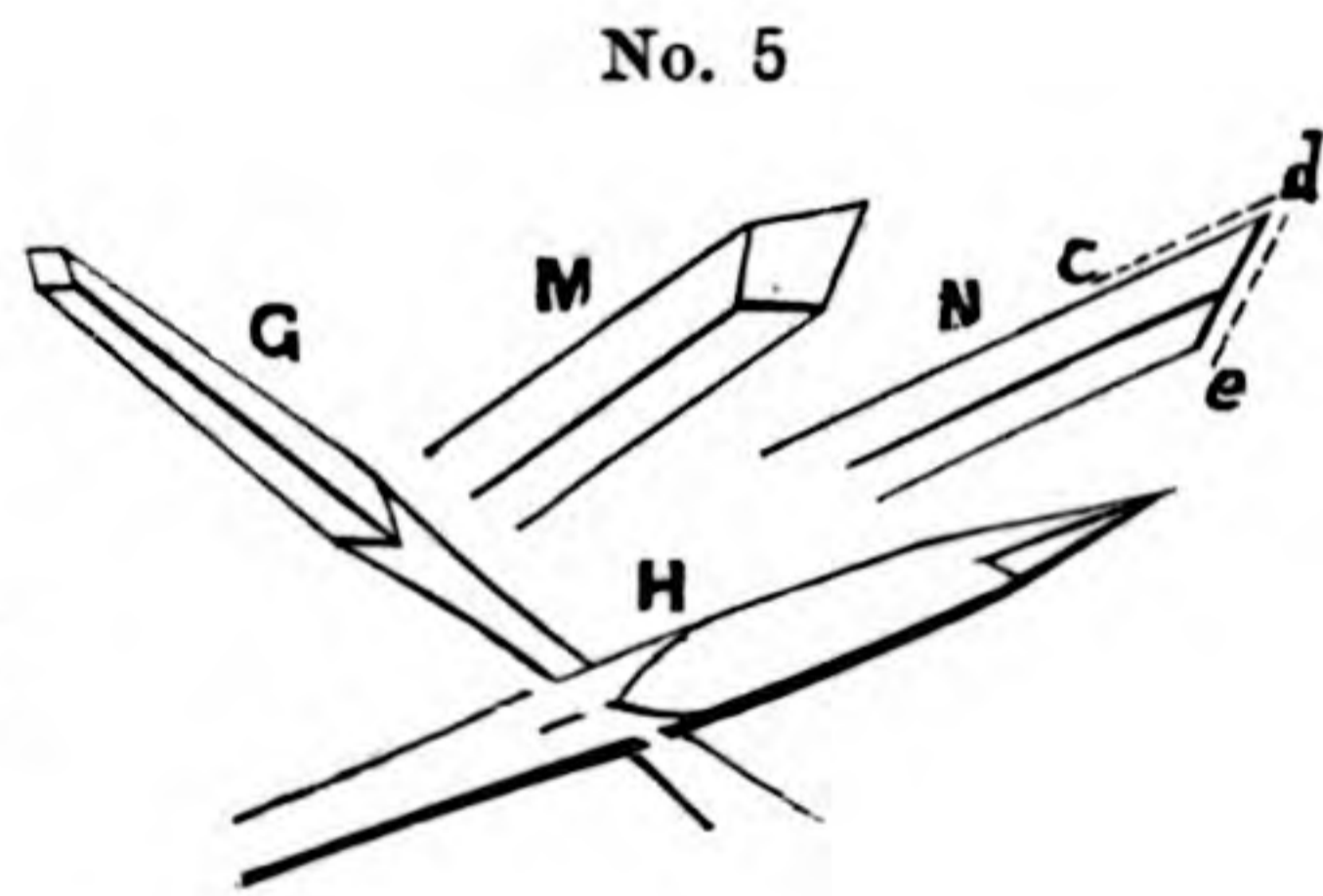
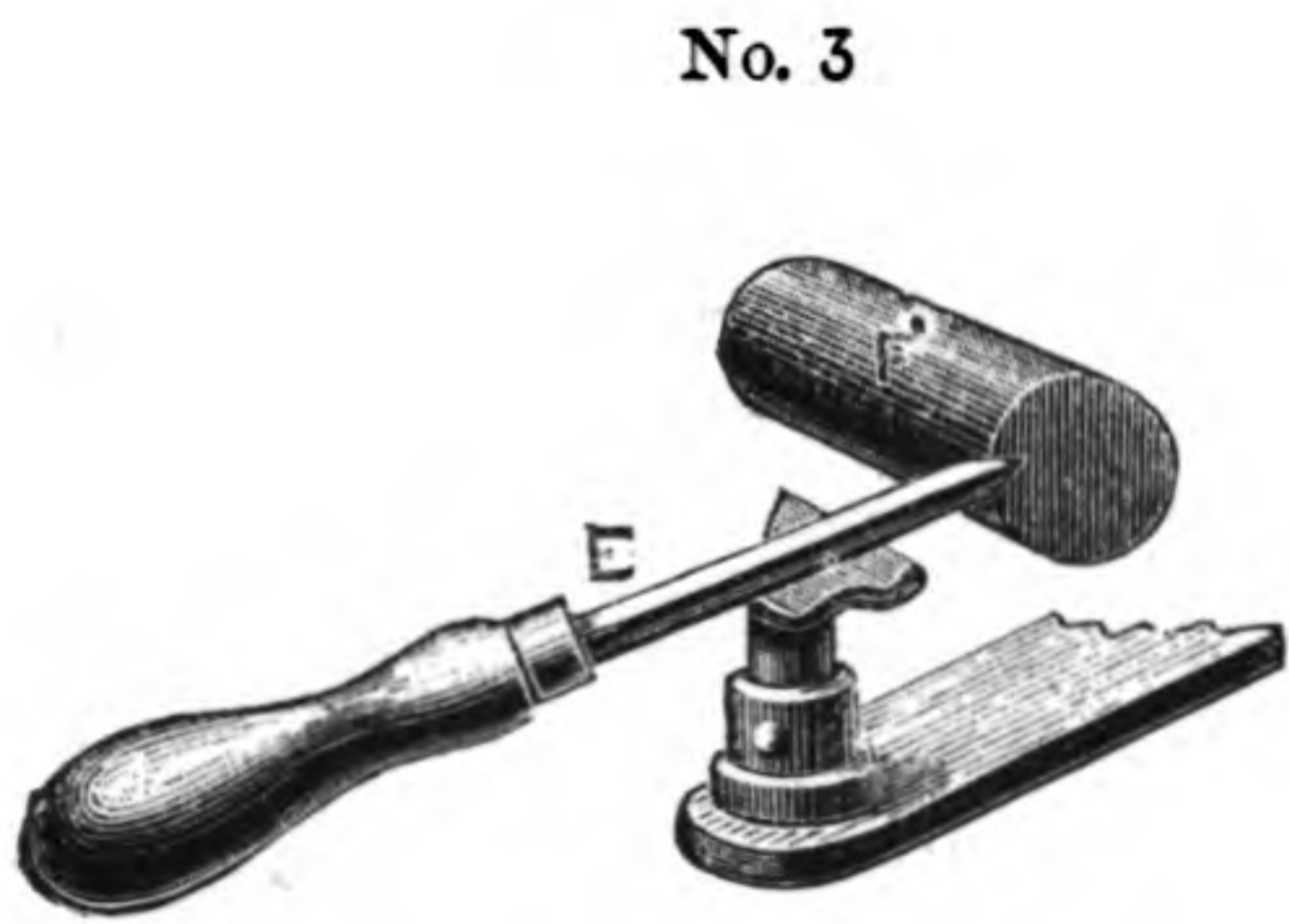
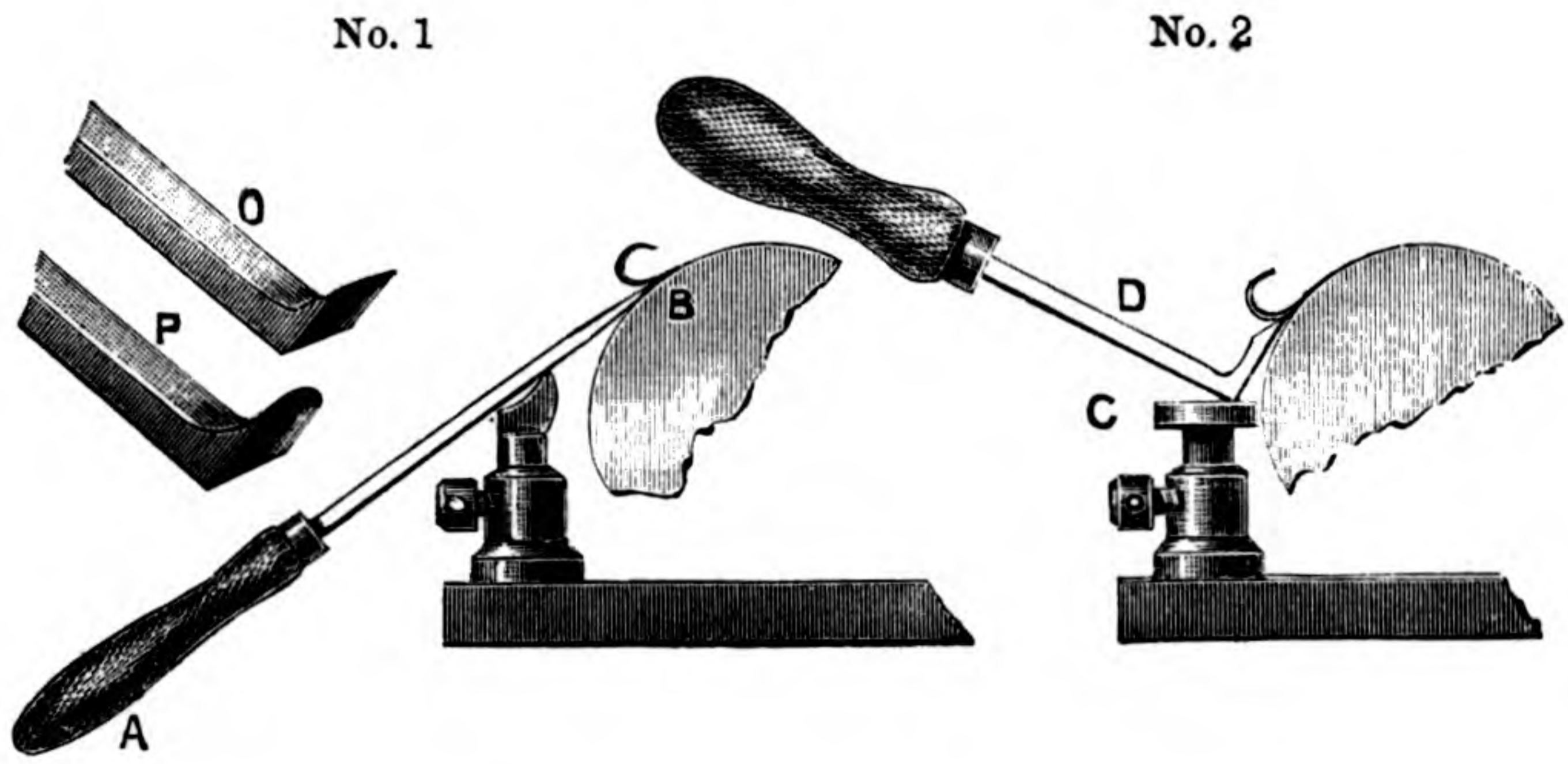

No. 6



No. 4

PLATE IX.—METAL-TURNING BY HAND TOOLS.

as fulcrums to assist in steadying the tools and prevent them from slipping sideways out of cut. They are easily fitted, and will prove of great convenience, saving the muscles of the hand and wrist a good deal of hard work. It will be seen at a glance that metal-turning tools, used by hand, cannot be run along the surface of work as wood-cutting tools are, but must, for the most part, be swept round in short curves, then shifted, and a similar cut made. The ridges between these curves are then attacked and the surface levelled by degrees in stages. But very good work can, nevertheless, be so done, and metal-turning by hand will be found far more interesting and easy than might be supposed; even with a slide rest at hand, it is impossible wholly to lay aside hand tools.

It may, indeed, seem strange to the ambitious tyro, whose heart is bent on a slide rest, to be told that hand tools are easier to use, and that he must not think for a moment that all he has to do is to put a tool in the rest, turn a handle, and produce excellent work. If it were so, a Lathe man would hardly need the apprenticeship which he is called on to serve. But it is equally true that the use of hand tools may be very quickly acquired, and that good work may be done with them. The principle guiding their use is, nevertheless, exactly the same as that which governs the others; and it is, perhaps, accuracy of position which is of more real importance than accuracy of the cutting angle of edge. For instance, if a cutting edge of 60deg. is the best for wrought iron, one of 62deg. or of 59deg. would cut it almost as well; but one of 60deg., though perfectly ground, not placed exactly right, will do far worse work than one of 70deg. placed correctly. The rule, which is so generally applicable that it may be taken as absolute, is to keep the lower face of the tool, or the face which is nearest to the surface of the work, as accurately tangential as is possible while allowing it to cut—in a word, keep it almost in contact, but not quite. The graver will illustrate this better than any other. The back of the tool is seen at E, No. 5, and the front of it is like M, the side view or profile N. Now, in order to set this tool into cut, let it first lie quite flat against the end of the bar—i.e., lay

the bevel, or sloping face, of it in that position. This is technically called "without any clearance." Draw back the tool upon the rest, so as only to let $\frac{1}{16}$ in. of its point overlap, but still keep the face as before. Now tilt up the tool very slightly indeed, giving it a very small clearance angle. It will at once cut the metal beautifully. Increase the clearance more and more, noting the result. It will be found to cut worse and worse. Take up the triangular tool, and try the same. It will shave off quite a broad, thin shaving if the clearance is very small, a thicker one by tilting it a little more; but presently it will be found too much tilted over for good work. Either tool may be held in one hand, easily, with a small clearance, so slight is the resistance. Nothing can teach better than this the fundamental principle of a small amount of clearance. This lesson is preparatory to the right understanding of slide-rest tools, the difficulty with these being the impossibility of thus gently altering the angle of clearance, or of slightly varying the position of their edge, or edges engaged with the work: yet it is this very slight variation that makes all the difference between good cutting and bad. It is the same with the heel tool (D of Plate IX.) The lower face, next the work, must make a very small angle with the bar upon which it is engaged, in order to cut the material easily and smoothly. It is just the same, but is not, perhaps, so plainly perceptible in turning hollow work with the triangular tool. Experiment may here, however, be made with great advantage, because, if the tool fails to cut as it should, it must necessarily be because it is not correctly placed, as its angles are 60deg., and are quite the best for use on wrought iron. We may now go a step further. Suppose D (the heel tool) to be placed correctly in the drawing—which it is—it will be seen that, if the handle is lowered, cutting will cease, and the tool will rub against the work. This, therefore, is our limit in that direction. But what will result if we raise the handle? Not only shall we increase the clearance angle, but we shall also alter the position of the top face of the tool, and shall bring it more nearly into a horizontal position. From this another evil will result. The shaving will be bent up sharply, pressing upon the top face

of the tool, and greatly adding to the resistance; and, at the same time, the edge of the tool will become more of a scraper than a cutting tool. It is just the same as with a knife. If you want to cut a pencil, you lay the blade pretty flat. If you wish to scrape the lead to a point, you set the blade up on edge. In the first case, the clearance angle is very small; in the second case, it is actually 90deg., or a right angle. This will show how we are limited in the position we can give a turning tool.

As regards speed for metal-turning, it may be briefly stated here that cast iron needs a very slow speed, and this is best obtained by back gear, which is very useful also for boring metal. But wrought iron of small size may be turned by means of the slowest speed on the flywheel, and brass can be cut upon the next speed, or the first on the rim of the wheel. Small brasswork, indeed, may be turned at the same speed as hard wood. The finishing touch is given to brass by a planisher, as it is called, which is, in fact, a flat tool, thin at the edge, and ground off square; and if this tool is rubbed with a burnisher after being ground and set, it will in turn, not only cut the metal, but leave upon it a burnished surface, which looks exceedingly well on any fillets or beads which form rings above the general surface. These may also be finished with the milling tool, which acts by pressure, and impresses its own pattern on the work while revolving in close contact with it. Heads of screws to be turned by the finger and thumb are nearly always thus finished, as the minute teeth so formed produce a rough surface, not liable to slip when laid hold of. There is one vexatious tendency in brass which often causes trouble—namely, its tendency to chatter or vibrate under the action of the tool. This causes a series of striæ, or minute undulations, to be cut on its surface, which, once begun, are difficult to check. The only way to prevent the mischief appears to be to move the tool ceaselessly, so as to alter the direction of the vibrations constantly, thereby counteracting them. A similar result may be attained by a pad of sole leather on the rest, or by allowing the tool to bed itself partially against the thumb and finger. But short cuts, with the tool slightly tilted,

and frequently altered in position, are the most general antidotes. It is, however, often necessary to go over the whole surface with a router, or round-end tool, to get rid of striæ formed in a few seconds. Some kinds of brass are more subject to this tendency than others.



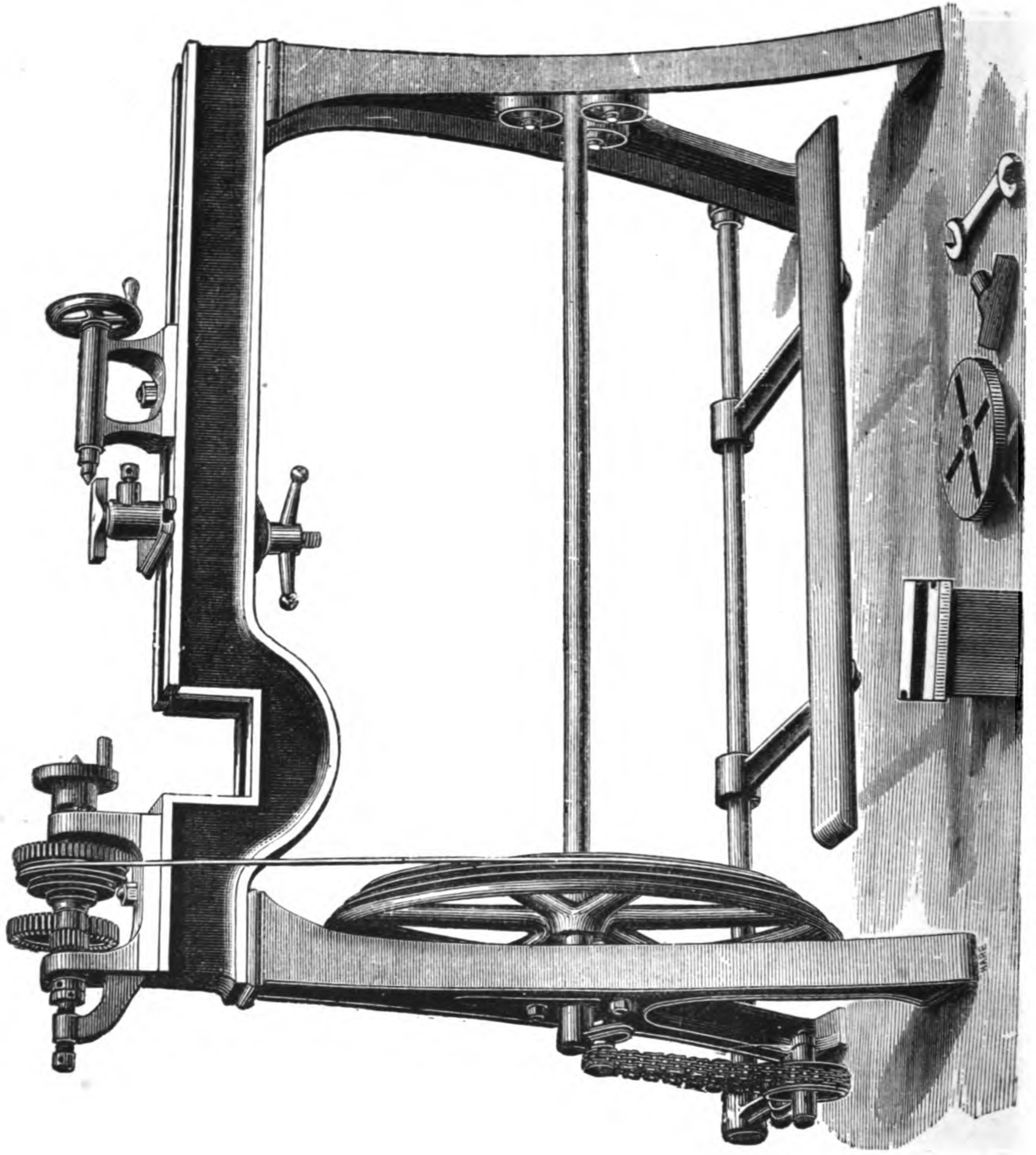

PLATE X.—BACK-GEARED LATHE, WITH GAP FOR METAL.
(Made by Britannia Co.).

CHAPTER V.

SLIDE-REST WORK IN METAL.

IT will be as well to commence this chapter with a description of one or two Lathes more specially suited for metal-work than those already illustrated, which are chiefly for beginners, and for work of small size. The Lathe of which an engraving is given here, is a very strong one, and is made from 4in. to 6in. centre. It has back gear for slow motion, and can be had with extra hard mandrel and steel collars, but is generally made with gun-metal collars. Price, £13 to £18; weight, 4½cwt. The crank shaft runs on friction rollers, and everything is done to prevent the Lathe from working heavily. Such a Lathe as this is powerful enough for metal-work of a tolerably heavy character, and should be fitted with a good strong slide rest. This latter Lathe appliance has gone through many changes of form, but consists mainly of two slides, working at right angles to each other—the lower one moving to and fro across the Lathe bed, the upper moving parallel to it. There is, however, in addition, a quadrant plate, allowing the upper part to swivel round horizontally, so as to adjust the tool for turning cones. Sometimes the upper slide is made to advance or withdraw the tool, and the lower is the one parallel to the Lathe bed; in which case, the whole rest is fitted with a sole plate, or foot, similar to that of a hand rest, and this—which generally slides on a separate cradle, fitted on the Lathe bed, to keep it accurately square to such bed—constitutes a third slide (see Fig. 8). The rest is good for special purposes, but not so

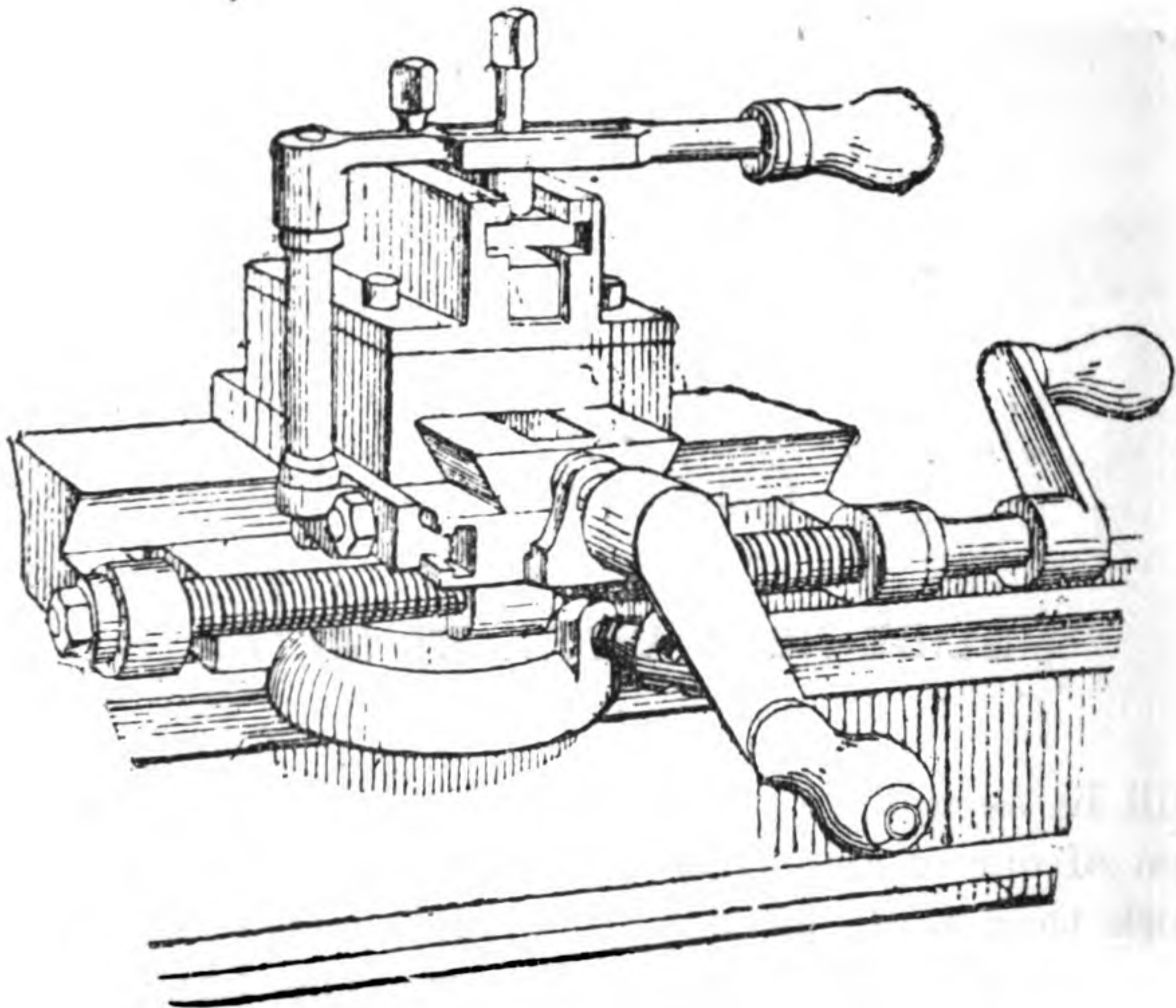

FIG. 8.—W. S. BROWN'S SLIDE REST.
(Made by Britannia Co.).

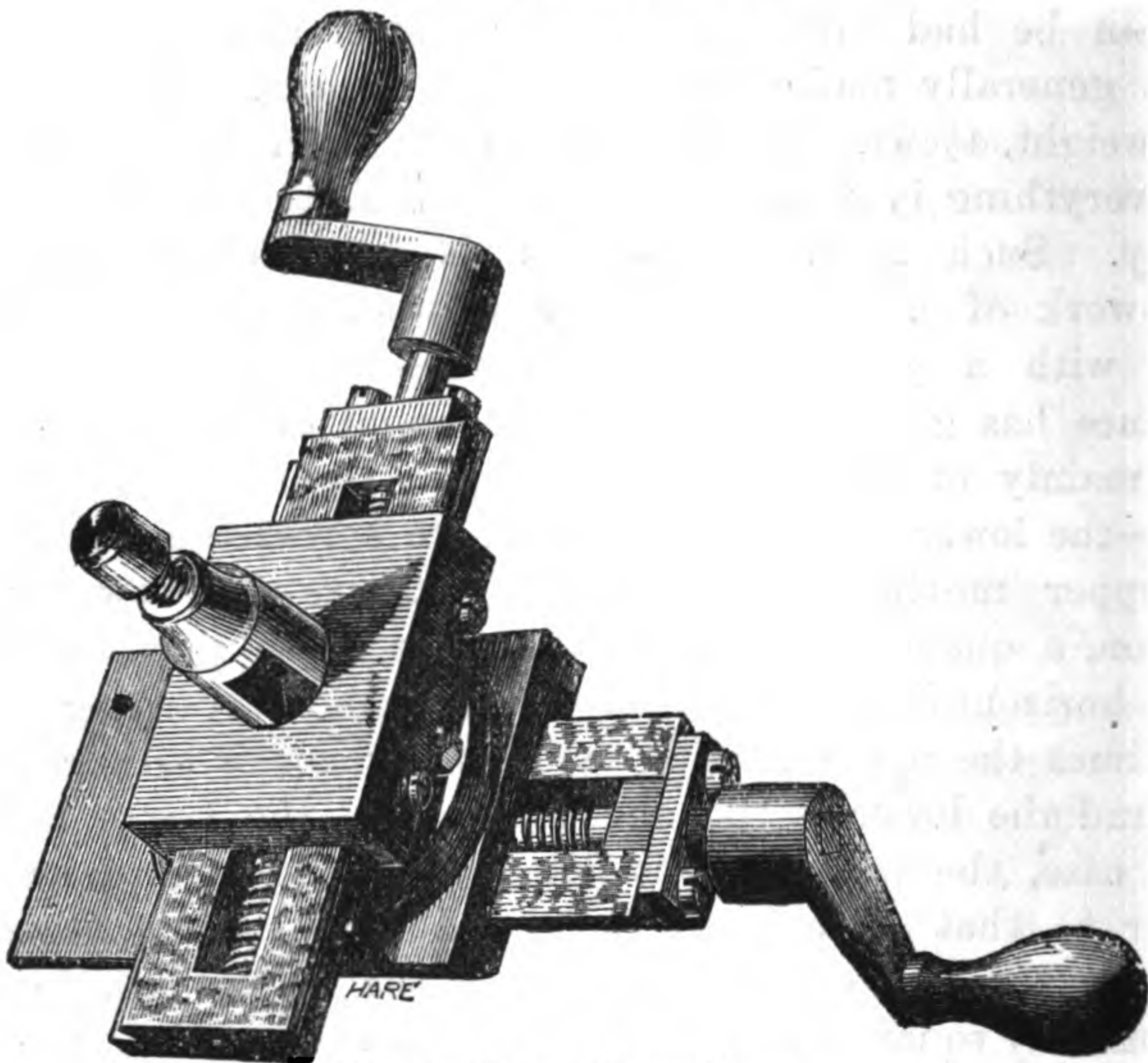

FIG. 9.—SMALL SLIDE REST.

well suited for general metal-work, where the greatest rigidity is needed. A small slide-rest of the ordinary make is

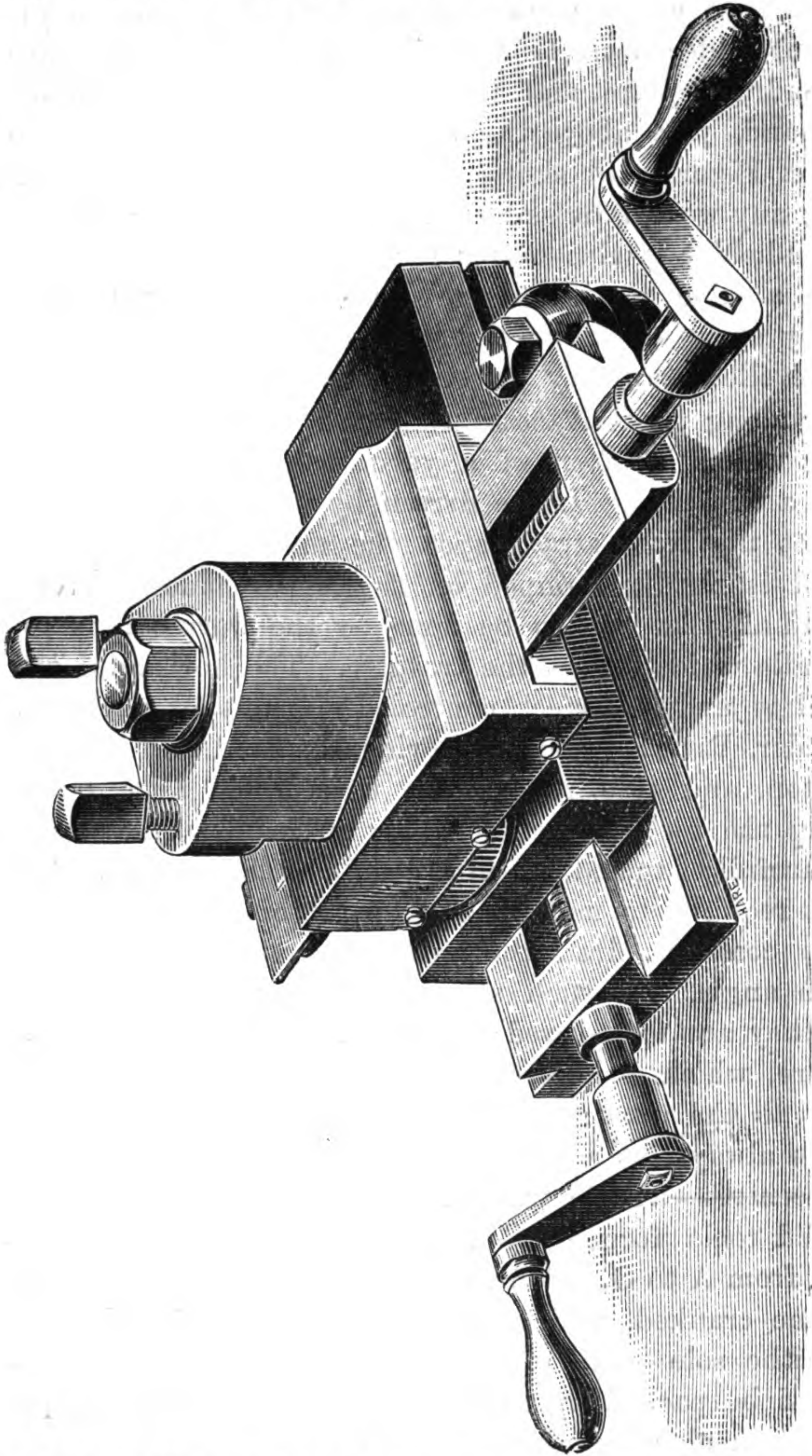

FIG. 10.—STRONG COMPOUND SLIDE-REST.

illustrated at Fig. 9, and is a very useful one for the lighter

D

Lathes to 4in. centre already described. Below, and parallel to the top frame, is a tenon, to fit accurately in the bed of the Lathe, to which it is attached by a bolt and hand nut. The tool-holder swivels round to any horizontal position. The quadrant plate and its clamping nut are seen on the right hand, just above the square plate of the lower slide. The next Figure (10) shows a much stronger rest, suitable for turning any work admissible in a Lathe of 5in. or 6in. centres. The tool-holder is also better for heavy work.

With a slide rest it is no longer necessary to cut the metal by short strokes, which produce inequalities demanding to be levelled down by subsequent cuts. The tools traverse steadily along the surface of the work, removing a continuous shaving which is often of a yard or more in length in the case of a self-acting Lathe driven by steam. There is, moreover, not the least strain upon the muscles of the hand, as the tool is rigidly clamped on the upper plate of the slide rest, and all that has to be done by the workman is to turn the handle which causes the traverse. The horizontal angle of the tool is under perfect control by means of the swivelled tool-holder, but all others are evidently fixed and unalterable; front, top, and side rake being determined once for all in grinding the tool. If the chapter on hand turning tools has been carefully studied, it will not be difficult to understand what is required to make a slide-rest tool act perfectly. We have to consider, first, the cutting edges, which must be of such an angle, and such sharpness, as to suit the metal on which they are to be used; secondly, the low clearance angle, as before, which brings the front face or faces at nearly a tangent to the work; and, thirdly, the height of cutting edge, which is always, as a normal rule, to be at the height of the Lathe centres—a rule which it is rarely necessary to alter. The solid tools forged from steel bar are represented here, Fig. 11, from A to G. Some are straight, some bent to right or left, some cranked, and others for inside work. They stand flat on the sole plate of the rest, always lying horizontally. They can be packed up to exact height of centre by parallel slips of iron placed underneath them.

One of the most common tools for roughing-down work is

the round end or router, Fig. 11, A; bent to the right or left if the work requires it, B. If well ground and correctly placed, it takes a good bite, and gets over its work rapidly, but does not leave a finished surface. It is, in fact, the gouge of the metal-turner. Another tool for the same purpose is the point or diamond point tool, C. This is a more delicate affair, and it leaves on the work a fine spiral line, which is, in fact, a screw of very fine pitch. These tools are, for iron, bent up somewhat, so as to give an inclined upper face, because the tool cannot be held at a tangent like a wood chisel, and the top face must therefore be ground permanently to a suitable top angle. Then, again, if we look down upon the top of the tool and work, as in the plan view, Fig. 12, S, we shall

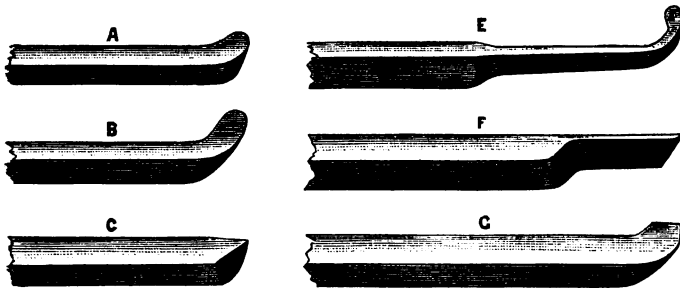

FIG. 11.—SOLID FORGED TOOLS.

see that the cut is made by the left side of the curved end as far as the dotted line, supposing, for the sake of distinctness, that a deep cut is taken. The tool is travelling to the left in the direction of the arrow. The part *a*, therefore, which leads, must have its clearance, or it will rub against the side of the cut; and the point or front must have clearance, or it will rub against the cylinder. To get a good cut out of this tool, the top face or top clearance should be ground in the direction of *a b*, and not straight down towards the shank. This will give what is called "side rake," rendering the tool sharpest where the line *a b* touches the work. This is easier to manage if the end is not only bent up, but bent over towards the left, like B of the set just described.

To make still more clear the principles which guide the action of slide-rest tools, we must recollect that a shaving has to be detached in two directions—viz., from the shoulder *a* of *K*, Fig. 12, and from the surface of the cylinder at *b*. A shaving has to be thus separated at two points, and, to effect this in the best way, it must be cut, and not torn, in either direction. Hence, a perfect tool must evidently have two edges—a front and a side edge; and, as it is the ultimate object of turning to leave a smooth surface upon the work, it is evident that the tool edge which cuts this cylindrical surface must be formed and

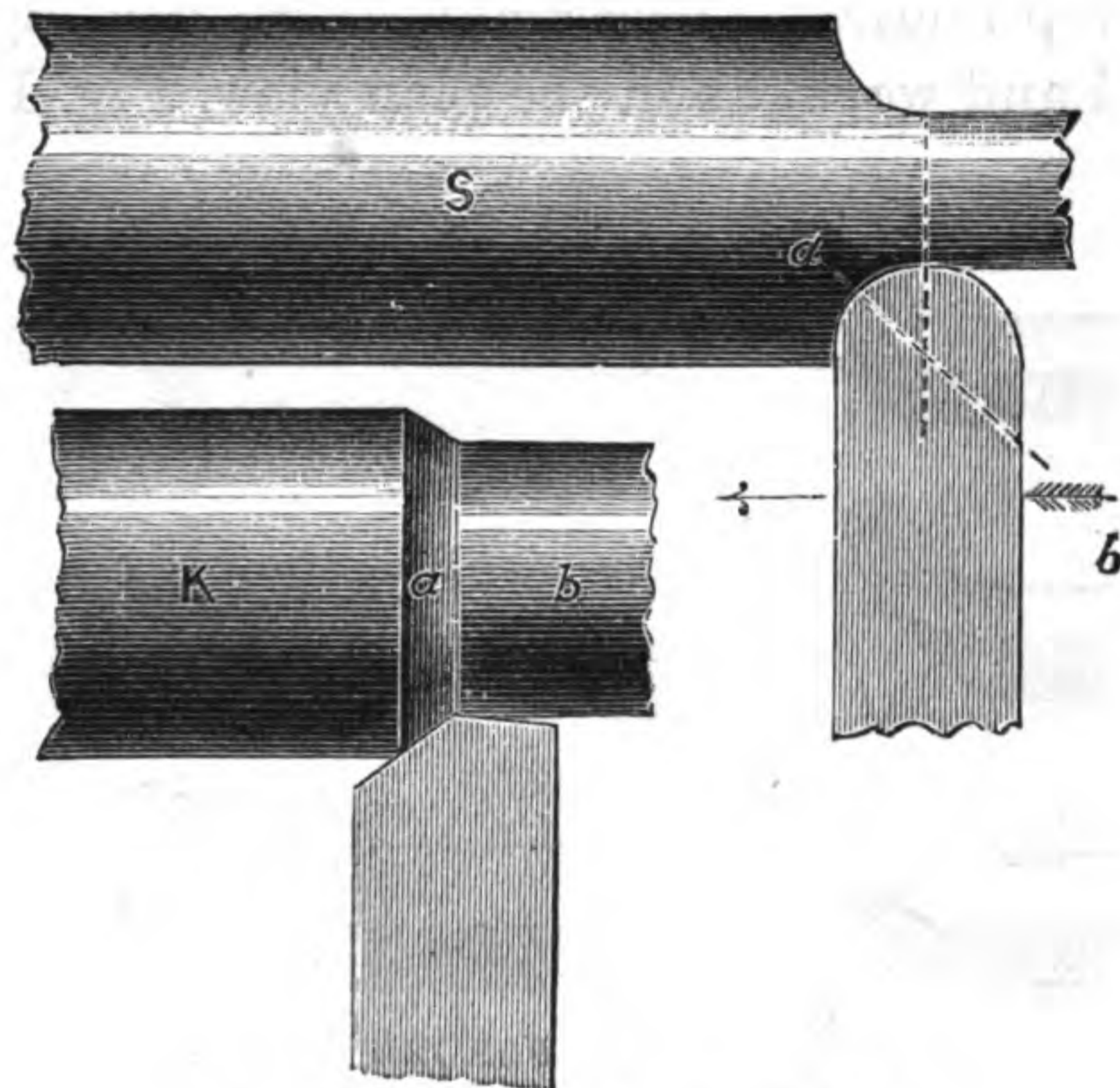

FIG. 12.—SLIDE-REST WORK.

sharpened as carefully at least as the other, although the latter, as the leading edge, has most of the work to do, and, if there is any difference, needs to be sharpest. This is the double-edge principle, which is often regarded as a sort of scientific theory suited only for amateurs, and of no real use to a workman; but it is not so: it is the fundamental principle of slide-rest tools—easy to understand, and equally easy to apply practically; and no chapter on tools would be complete without an explanation of it. In a round-end tool we may take half the edge as the leader and the other half as the follower; as we may suppose it to be, what it practically is, a double-edged tool of very wide angle, with

its extreme point rounded off. It is a very common practice to apply a tool *end on*, whether pointed or rounded (A and B, Fig. 13); but evidently the tools, after having started, cut no further than to the dotted line dividing them centrally, and the part x , x might be cut away altogether. Where, then, is the second edge of the point tool? Nowhere; and hence the shaving is torn, and not cut, in that direction, and a rough line remains on the surface of the work. Power is also

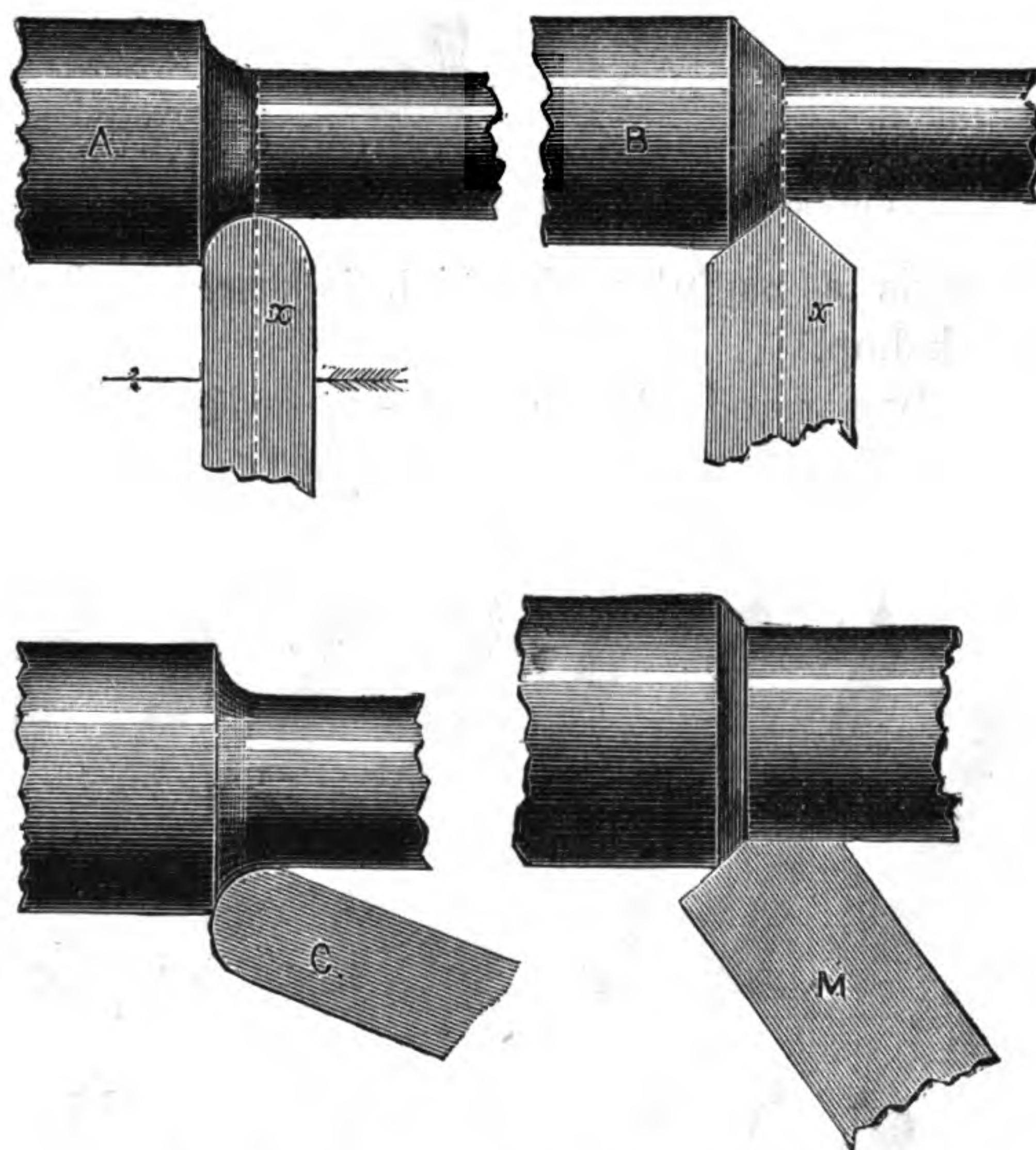

FIG. 13.—PRINCIPLE OF DOUBLE EDGES.

wasted, because it takes more power to tear apart the particles of iron than to cut them cleanly. An "end-on" tool is not, therefore, a scientific one, its proper position being that of M, so as to bring both edges into cut. The same is true of a round-end tool. It is evident that here the extremity is the sharpest part of it, and that the edge gets gradually blunter, as it is situated further and further round the curve; then it is plain, from what has been said, that it should not stand "end on," like x of Fig. 13, because the

blunter part at the side is leading. Placed as at C, or bent to the left, it will cut much better. It is never *quite* satisfactory, owing to the sharpness of edge varying all round the

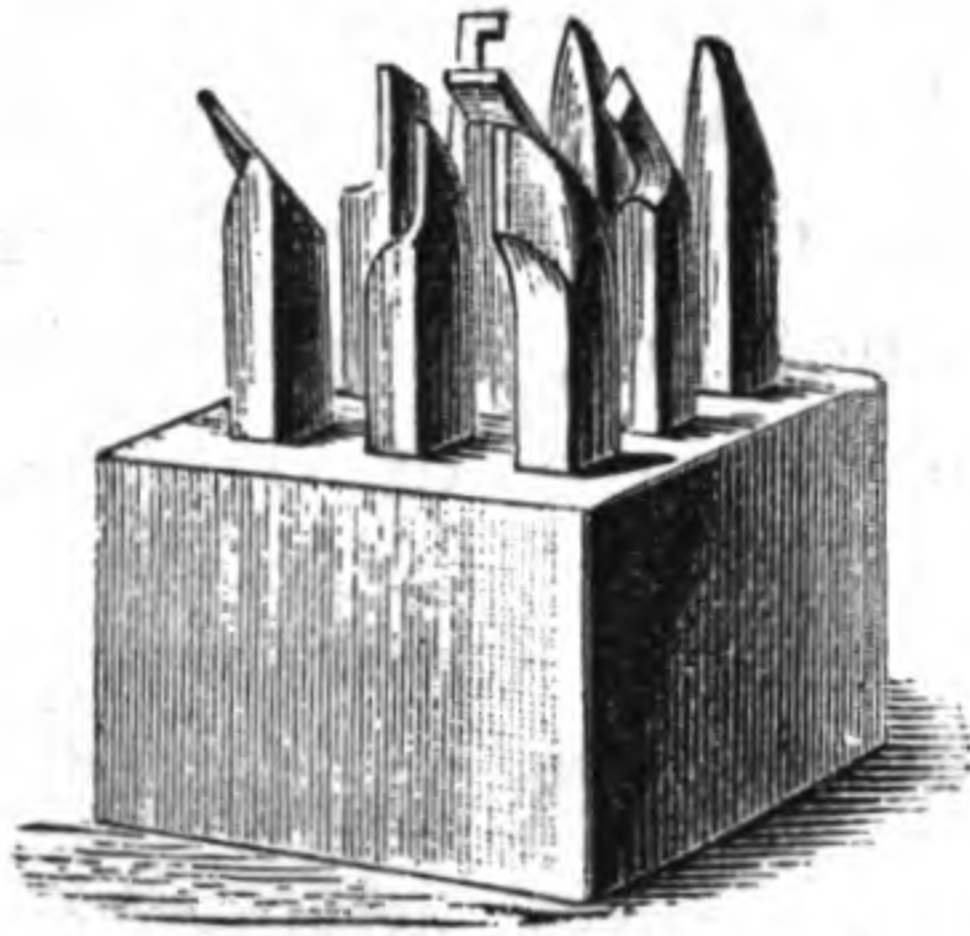

FIG. 14.—SET OF TOOLS FOR SLIDE-REST.

curve, but it is a useful tool which is sure to find a place in every workshop.

The variously formed slide-rest tools ordinarily supplied in



FIG. 15.—VARIOUS SLIDE-REST TOOLS.

complete sets are illustrated together in Fig. 14, set up in a block, and in Fig. 15 they are shown separately; and it would

be difficult to devise other shapes, as there can hardly be any work, hollow or otherwise, which one or more such tools will fail to cut. The three on the right hand of the second row are, however, not solid tools, but bars with loose cutters—the first for outside, and the two others for inside work. Of the first, in all its details, we shall speak very fully under the head of the Haydon Bar. The others have square shanks to lie upon the rest, and are then turned for the remainder of their length. At the end is a small mortice, which is cut slightly conical, and is intended to receive small bits of steel, filed to fit the mortice, and then sharpened and hardened. The mortice is cut either square to the bar or at an acute angle, by which plan the cutting end of the tool is made to project a rifle beyond the end of the bar, for the purpose of

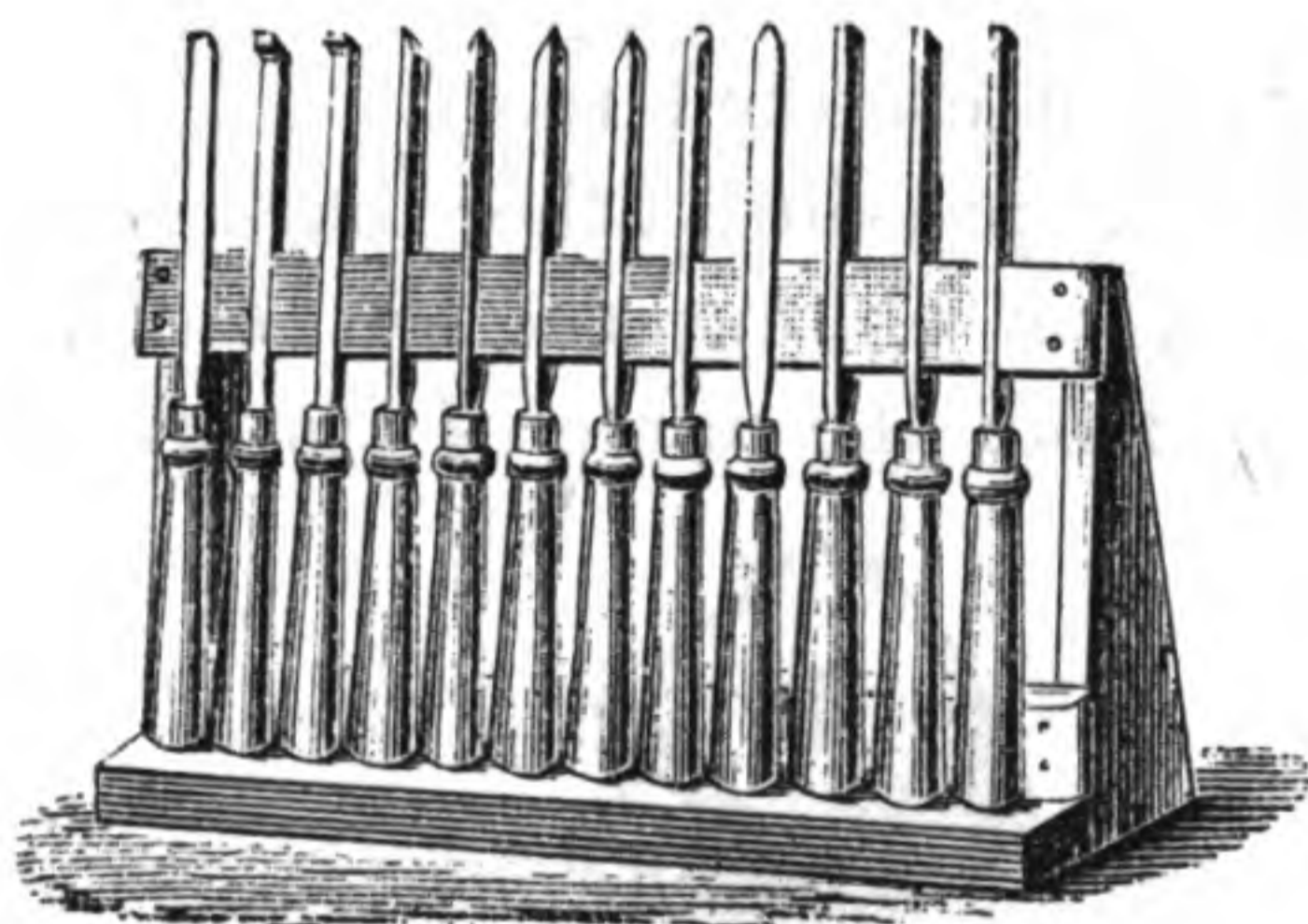

FIG. 16.—STAND FOR TOOLS.

getting into corners. These replace the holing or boring tools, of which E, Fig. 11, is a larger drawing. Third from the right, in the first row, is a drawing of the knife tool. Of these, there are always a pair. The edge is on one side, and the tool is meant to true up the ends of cylinders and sides of collars. It is ground to a very slight clearance angle in the face next the work, and will take off a broad, thin shaving. The left-hand tool of the second row is a spring tool for finishing off a shaft; it acts as a chisel, and cannot possibly hitch in. The edge is placed almost parallel to the work, but so as to keep the angle clear.

Illustrated here (Fig. 16) is a very simple stand for tools which is most useful, as each tool can be seen at a glance. This one is for handled tools for wood.

The further consideration of this important subject will be better carried on in connection with cutter bars, especially as these are fast displacing the solid forged tools of which we have been speaking. Those that are cranked are made on the same principle, but are more convenient to grind, and naturally lead up to the cutter bar, as they may be considered



FIG. 17.—PRINCIPLE OF LOOSE CUTTERS.

as a shank acting as a handle to support a straight bar, ground off at an angle at its upper end (see dotted lines in Fig. 17, representing a cranked tool).

Passing by, for the present, other bars which are made to hold round, square, or oblong section steel, we may go at once to one called, from the name of its inventor, the Haydon

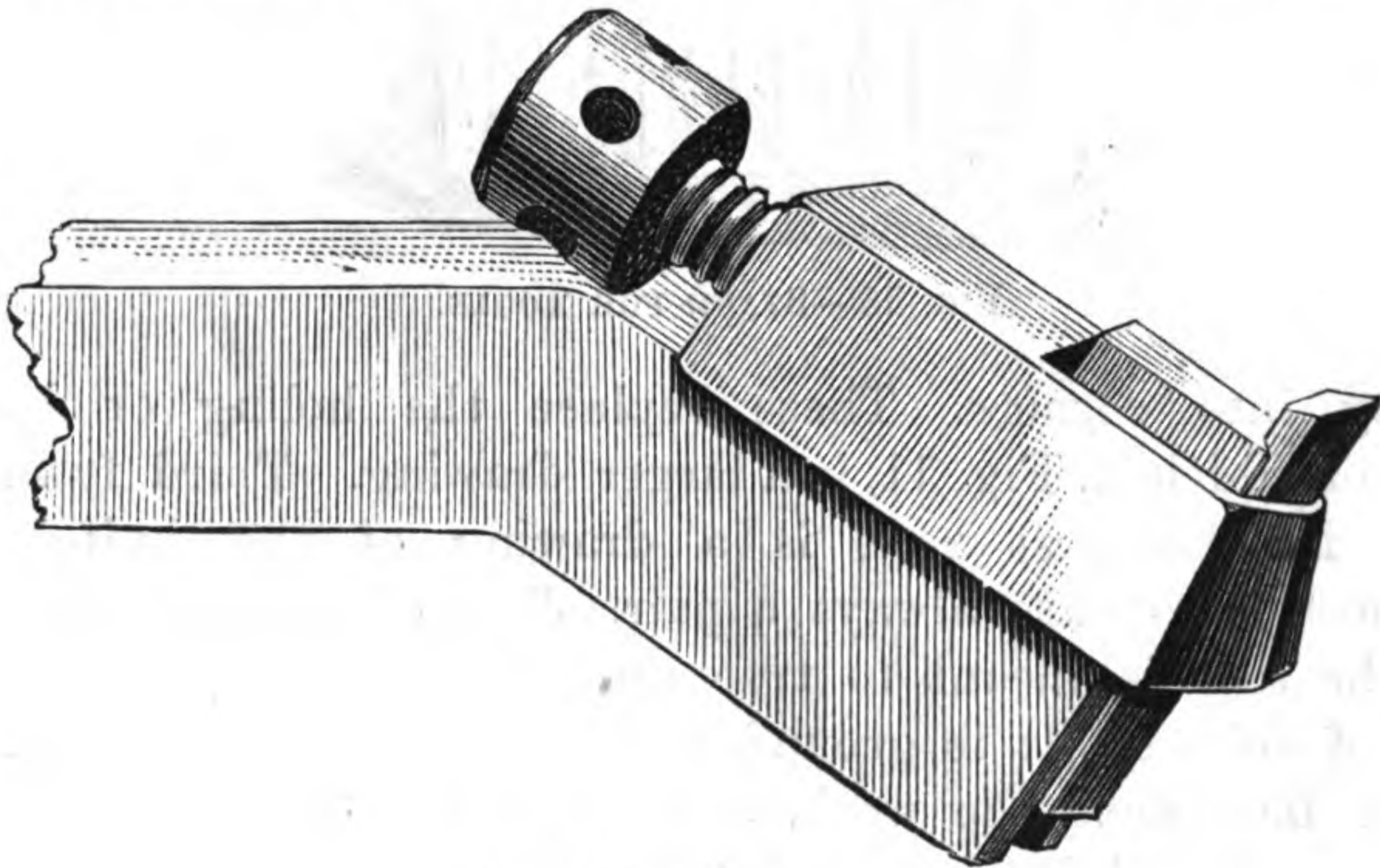

FIG. 18.—HAYDON BAR.

Bar. It was designed to carry out to the utmost the principles of double-edged tools. Intended chiefly for square section bars, it will also hold round ones and gouges—the latter being, of course, broken off into short bits about lin. long. Fig. 18 represents this bar, and its construction is evident

at a glance. It is sold, accompanied by a full printed description, and with directions for grinding the little cutters. The price varies from 9s. 6d. to 17s. 6d., according to size. The top part, or sling, is a separate piece, and the clamping screw, by drawing it up towards the front end of the bent part of the bar, grips the steel cutter firmly. The latter requires to be ground on three faces—two in front, and one on top. This gives full scope to the workman, in shaping the tool, to meet all requirements. The bar can also, for special purposes, be bent to either side, but it is seldom necessary, as the cutters can be shaped to cut in front or sideways. It is not, however, possible to use such bar for boring and inside work. For this a straight one is used, or an ordinary solid boring tool. In the engraving of the bar we see the top face of the cutter, and one of the two lower ones, the other being precisely similar. In these we have to get, not exactly *front* clearance (nor does the front line signify), but the clearance of the one face of the tool, which will lie against the shoulder, and of the other, which will be opposite to the cylinder. The meeting of these two with the top face produces, evidently, the two edges which are to remove the shaving. Naturally, we should first grind the front faces, and for this the tool is pushed up, after slackening the screw of the sling, so that the latter may not come into contact with the grindstone. If the shank of the bar is laid on a wooden block resting on the bearers of the grindstone, and the bar is slewed round so as to bring parallel to the stone the face which is to be first ground, a few turns will grind it. The slope, or clearance angle, will be greater or less, according to the height of the block, and the distance the tool has been pushed up in its sling. The thicker the block, or the higher the tool, the greater will be the clearance produced, because the stone will grind more the heel or lower part of the face on which it is engaged. Take Fig. 19, A, to represent the cutter, held up with its two lower faces towards you, and B, the side view which will, of course, show but one face; this will be ground with not much clearance. Then C and D will be similar views, in which the grinding, carried lower down the tool, has produced longer faces—*i.e.*,

more clearance. But observe, it is the *face*, and not the middle line, of which we are speaking: this front clearance we have nothing to do with so far. The slope of it depends on the grinding of the faces, and may be called accidental.

But now it will come into use in quite another way. As yet we have no edges, the shape being like E, if it is a square tool not ground before. Its side view will, in this case, be represented by F. It has, therefore, to be ground off on about the line x, y , until the square end is obliterated. It is now that the front line comes into service, for, in grinding the top face, it will make a given angle with this line, and according to that angle will the sharpness of the two cutting

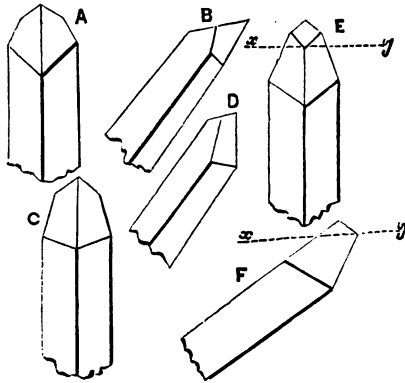

FIG. 19.—GRINDING CUTTERS.

edges be. All this, when it has to be put into words, appears very complicated; but now it has been once explained, it can be summarised in a few words. To grind a cutter: Set the bit of steel up in the sling, to prevent the latter from receiving damage; lay the shank on a block, resting on the bearers of the stone; grind the two lower faces in succession at a tolerably wide angle—90deg. to 120deg., as a rule, will do. Take out the cutter and turn it round in the sling, so as to bring the face which is left to be ground outwards; lay it on the stone, and grind it to the desired angle with the front line. This is not at all complicated, after all; and when the

thing is being actually done, all will be seen clearly enough. Grinding this third or top face will obliterate the square, as it will bring the face to the line xy of this Figure.

Now here is at once seen the handiness of the cutter bar. There is no forging to be done. The little steel rods, $\frac{1}{4}$ in. to $\frac{3}{8}$ in., or in large bars $\frac{1}{2}$ in., square, are readily procured, and can be cut in lengths of an inch or two; and as they are gradually shortened by grinding, they are merely pushed up higher in the sling, so as always to bring the point of the tool to the height of the Lathe centres. After grinding, the steel cutter is not left standing up high, but is pushed down again, so that the point shall never stand above the level of the shank of the tool: if too high, it will have a tendency to chatter; and if it should catch in, it will probably also break.

We may now consider another point connected with the formation of the cutters. It is necessary to know how to obtain the two cutting edges of exactly the angle preferred—say, for instance, 60deg. for wrought iron. Now, this angle depends upon two things conjointly—first, the angle at which the two lower faces meet, called the plan angle of the tool; and then, secondly, upon the angle at which the top face is ground to the front line, formed by the meeting of the aforesaid faces. A graver is a square bar: it has, therefore, a plan angle of 90deg. Grinding off the face at 45deg., with the line formed by the meeting of any two given faces, the edges produced will be 60deg. each, and these are the angles usual with that tool. If we grind the faces of the little cutter, therefore, similarly to make an angle of 90deg., and then grind off the top face at 45deg., we get 60deg. of cutting edge. But an angle of 90deg. gives rather a weak point to the graver or to our cutter, and the latter is preferably ground to a larger angle, the faces meeting at 120deg. The top must be then ground to make 55deg. with the front line, and the result will be two cutting edges of 60deg., as before, but the point of the tool will be strong. The extreme point, even then, is preferably rounded on the oilstone.

One precaution has always to be taken, in order to produce two edges equally sharp, and that is, to keep the front line

formed by the two faces, and which will be upwards when grinding the last face, in the "run" of the grindstone. It does not follow that the line in question will be in the centre of the tool, because it is to be clearly understood that there is no restriction as to the direction of the edges. Fig. 20, A, B, C, may represent the grindstone forming the third, or top, face—the back of the tool, being, of course, seen. Then it may chance that, to get the middle line between the front faces right in the run of the stone, the bar may have to lie like B or C; for it may seem convenient to grind the first edge like the left hand of D, all on one side, so that the second edge, making 120deg. with the first, may lie square across the end of the bar. When the tool is

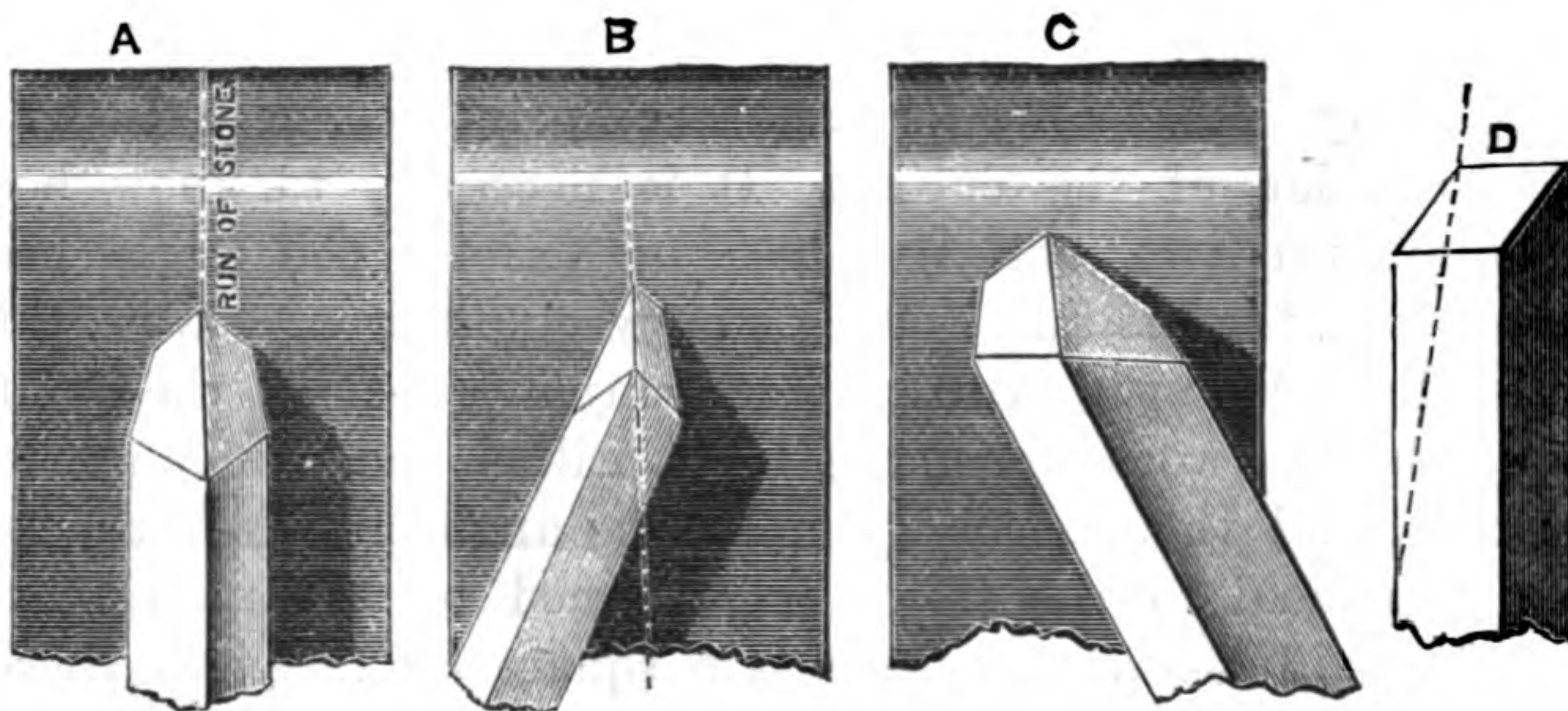

FIG. 20.—GRINDING THE TOP FACE.

reversed, it will have to lie as seen at C, or the edges will not be equally sharp. Such a tool, having its leading edge very much to one side, may be useful on the side of a flange or shoulder. The position of this leading edge is the first consideration. It will depend on the work: is the tool to cut more towards the right or left, or straight ahead? Grind that face to suit the case, and then grind number two at 120deg., 90deg., or, for a small corner, 60deg., or 55deg. for screw-cutting, and then the top face at such a slope or rake as to give the cutting edges desired. Consider, also, if you are likely to find in the way any part of the tool edge that will not be actually engaged. Generally speaking, only a small part of the edge is in cut. Then, if you like, file

away all that is of no use. Never mind the shape thus produced: all you want are the *edges*.

It is very advisable that every turner who wishes to take up this Haydon bar, and to work it thoroughly, should begin by what may be called the normal tool for outside work on cylinders. This is the simplest of the many possible forms; the angles are of a size easily remembered, and the work which it will do is of the very best. The front angle, formed by the meeting of the lower faces, is to be 120deg., and the angle made by the front line with the top face is to be 55deg., giving 60deg. as the angles of the edges. A notch in a sheet of tin, made by two three-square saw files held together, will make a gauge for 120deg.; a second notch made by one such file will be 60deg.; and a third notch, *marked* for 60deg. by a bit of tin filed to fit the 60deg. notch, and then cut a little within the marks, will serve nearly enough to measure the profile of 55deg. Of course, it may be done with mathematical accuracy, by means of a proper protractor, but the plan suggested serves fairly well as a workshop expedient. In grinding the two faces, the clearance may be stated at 3deg., as it has been shown that the smaller this angle is the better. After grinding to gauge, give a rub, face down, on an oilstone, and also take off with it the extreme point, rounding it just visibly and no more. This tool will, if rightly placed, do the finest and most beautiful outside work, needing no further finish of any kind. To place it, gauge height by the Lathe centre, after the bar is fixed in the rest, pushing up the cutter in the sling until it is exact to height; then clamp it by the screw. To adjust it now to the work, remember the principle is to be carried out of two edges—a leader to cut down the shoulder, and a follower to cut the shaving from the cylinder in such a manner as to leave it perfectly smooth, and, if desired, as bright as a looking-glass.

For this the follower is to lie almost parallel to the work, but not quite so. About two-thirds of that edge may, in fact, be allowed to cut. If the result is not a continuous shaving clean cut, examine for the cause, specially for the following—viz., too great clearance angle, and the tool point too high or too low; the latter, having, perhaps, resulted from screwing

down the bar in the tool-holder, after adjusting height of centres, with the bar merely lying upon the rest. Also, see to possible softness of the tool, a defect often overlooked. Nothing has, indeed, been said about hardening and tempering the cutters; but this is a matter of necessity, and a very easy one to accomplish. Just heat each, after forming it, to a full red, and drop it in a basin of water. This gives perfect hardness; and, though brittle, the tools will, with ordinary work, seldom break. But they are easily let down a little by heating a bar of iron, or shovel, red hot, and placing them on it until they take a light straw colour, or deeper straw, beginning to verge into blue. Then drop again into cold water, and they will stand well upon most bars of rolled iron. The latter may itself cause broken and short shavings, owing to cracks and defects; but, after a little practice, it will soon be seen whether this or the tool is at fault.

Never rest satisfied with bad work or hitching, chopping, scraping, or anything but an evidently clean cut. If not obtained, the grinding is faulty, or the tool badly placed. When both these conditions are correctly carried out, the tool cannot possibly fail to work well.

After thoroughly getting hold of both the principle and practice, by the use of the normal tool, another simple form should be tried—*e.g.*, one ground to 90deg. front angle and 45deg. top rake, which is exactly the graver used as a double-edged tool, instead of as a single-edged one, as it is when used by hand in the way already described. Then, taking the normal tool as a foundation, file away one edge almost to nothing, taking a great sweep out with a round file, and you have a tool for the side of a shoulder or an odd corner. File out both sides till you get a parting tool—and, in fact, see how many useful shapes you can obtain out of that one plain tool. You thus learn, step by step, the real value of the cutter-bar system. Even workmen who have never heard of double edges, or who scorn to depart from their ancestral inheritance of rule of thumb, do unconsciously adopt the principle when they give more top rake to that side of a round-end tool that is leading. They set the tool “end on,” at right angles to

the Lathe bed, and then find it cuts badly, unless the leading edge is higher than the other.

It is a rule in double-edged tools that, if any difference of acuteness exist, this extra sharpness of the leading edge shall be secured by leaning the tool slightly over in grinding the top face. But not only is this the case, but, whether recognised by the workman or ignored, it is a fact that nearly all his tools are double edged, and, in fact, must be so, unless he is content to tear off the shaving instead of cutting it. If a shaving has breadth and thickness (and some are of considerable thickness), it must be cut in two directions, and, therefore, two edges are a necessity, although they may be, and are, often disguised by being rounded off into each other. It is much better to admit this fact, and then to think out the result of it.

A workman thus using his intelligence will soon prove a better practical workman than he was before. There has been a vast amount of prejudice in this matter, which still exists to some extent, because a latheman who has learnt practically how to grind a tool, and how to use it, will not listen to any theory of why the tool in question was to be so ground or placed. But the result is that a great deal of Lathe work is very badly done, and that if any unusual job of turning is called for, demanding a special tool, the workman is at his wits' end to produce it; and if any tool works inefficiently, it very often happens that the latheman has no knowledge of where the fault is.

Technical schools are doing something to rectify matters; and probably before long the rule of thumb will find itself deposed, and that workman will get the highest wages who understands the theory of cutting tools, and can reduce it to practice.



CHAPTER VI.

THE SELF-ACTING LATHE.

IT will always be found difficult to turn the handle of the slide-rest so evenly that the work shall be left uniformly smooth and true. If the tool rests too long on one spot a deeper cut is the result, which, although very shallow, shows as a line upon the work; and this always occurs, again and again, when the slide-rest handle receives an intermittent motion, which, more or less, it nearly always does. Hence, for one reason, a self-acting motion is superior to that produced by hand, and this is easily managed by the aid of gearing or cog-wheels, and, with slightly less certainty, by means of cords and pulleys, generally connected to the mandrel through the medium of an overhead shaft.

But another reason for the adoption of self-acting Lathes is that in a factory one man can attend to two or three instead of one—a matter of economy that cannot be disregarded. And, thirdly, this mechanism enables a workman to cut screws of any desired pitch, say from one to sixty threads in an inch, with certainty; and also coarser screws called spirals, having perhaps but one complete turn in six inches. Apart, therefore, from such other uses as the self-acting Lathe may be occasionally put to, the above are ample reasons for its general use where much and varied work is carried on. The general form of these Lathes may be gathered from the accompanying engravings of Lathes, numbered 15 and 16 in the catalogue of the Britannia Company, of Colchester (Plates XI. and XII.). A screw

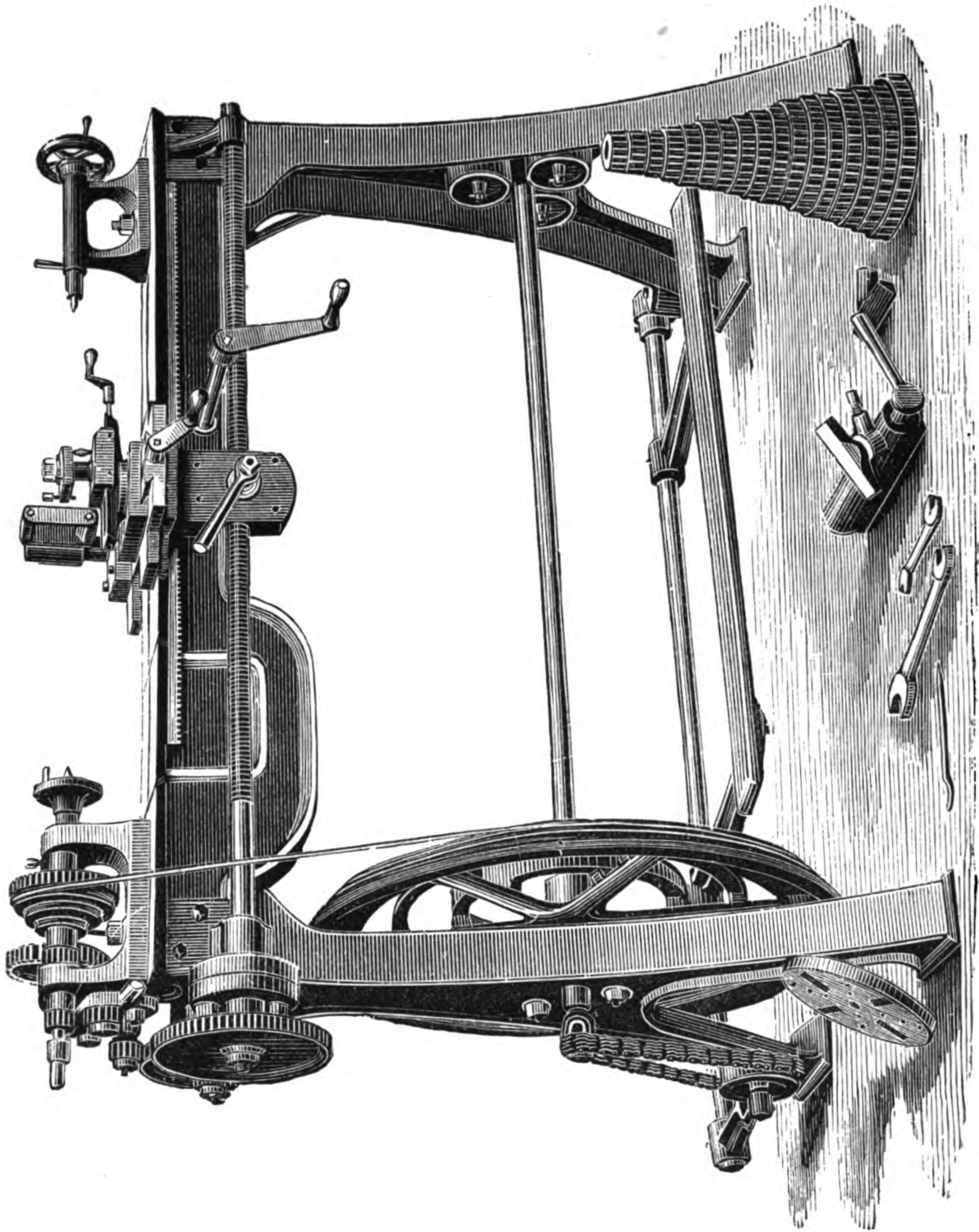
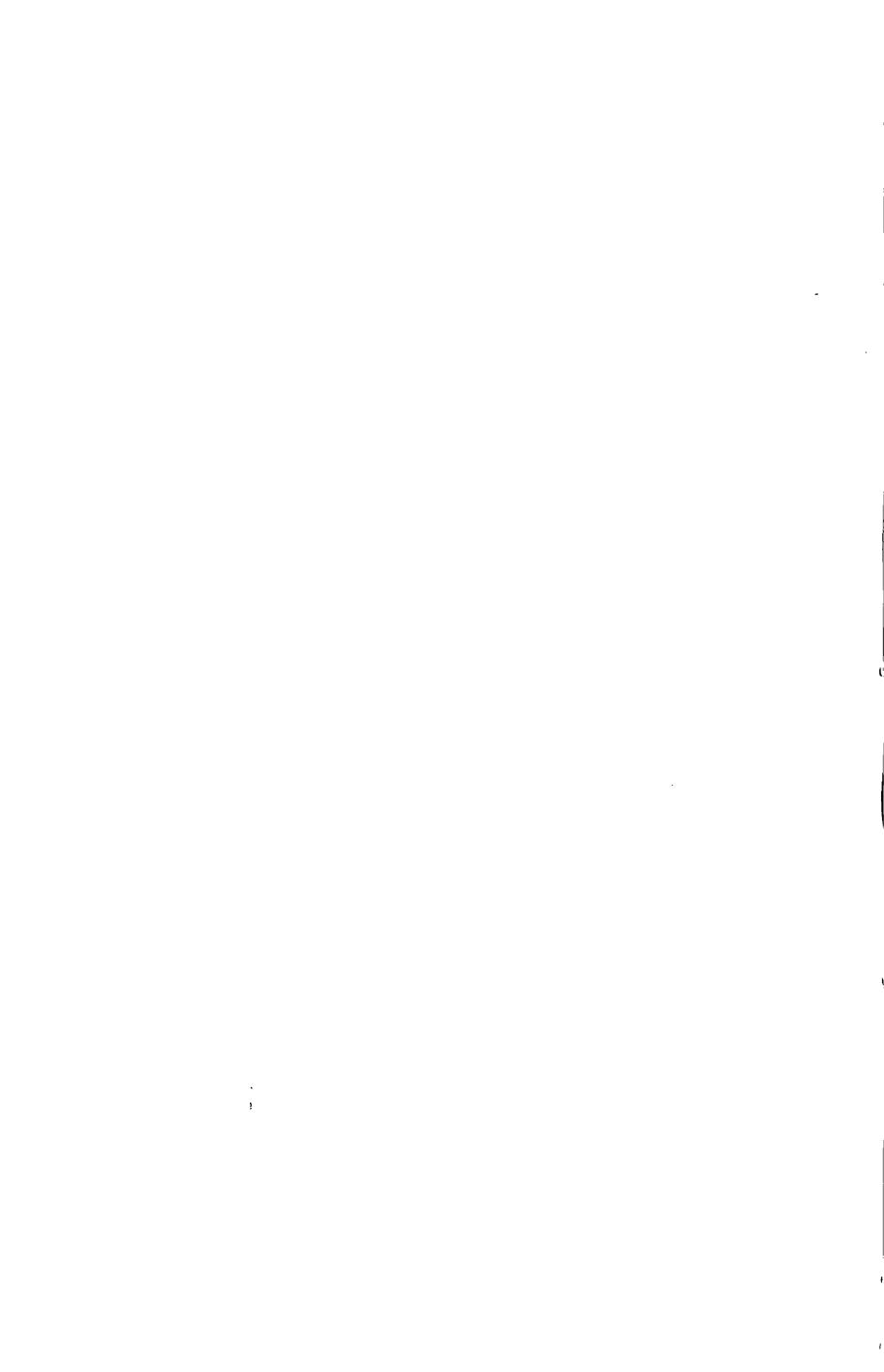

PLATE XI.—SMALL SELF-ACTING AND SCREW-CUTTING LATHE.



runs the whole length of the bed in front, of a quarter pitch—*i.e.*, of four threads to the inch. This passes through a nut in the apron of the slide-rest, just behind the straight handle. The rest is free to move along the bed from end to end, the edges of the bed being planed to a V shape, and being embraced by guide-bars similarly planed, and adjustable to take up wear. Turning the main or “leading” screw, as it is called, in one direction, causes the rest to travel from right to left, and reversing the motion causes it to return. This is the main principle of all self-acting Lathes.

But it is also evident that means will be needed to stop the traverse at any given point, without having at the same time to stop the Lathe. This is accomplished by sawing in half the nut through which the screw passes, and attaching each half to a short, vertical slide working in guides. The handle seen in front carries a plate with two spiral grooves in it, in which pins standing out from the halves of the nut engage, so that by turning the handle on one side the two halves are separated in an instant, leaving the screw free; while turning it back closes the nut upon the screw, and causes the slide-rest to resume its motion. The slide-rest is placed upon a saddle which fits to and slides upon the bed; and it is very often so made that the whole upper part can be removed, leaving the saddle free, so that work can be clamped upon it for boring or planing (if the Lathe has a planing head fitted to it). To the left is seen a large cog-wheel, attached to the screw, and by which, through other changeable wheels and pinions, the rate of motion of the screw can be varied, so as to give to the slide-rest either a quick or slow motion at pleasure. Two small wheels (seen on the left of the headstock below the mandrel) are fitted on the same plate, which is centred on a pin; so that either can be made to gear with the small pinion on the mandrel. This serves to reverse the motion of the screw, while the flywheel still continues to revolve in the same direction as before. Bolted to the back of the saddle, but removable at pleasure, is a die stay, or support for long work liable to bend under the tool. Being carried along the bar as the turning proceeds, and being all the time close to the tool,

it supports the work perfectly, and quite removes all tendency in it to deviate from its proper position. A drip-can, with soap and water, is also similarly mounted, to lubricate the work.

The action of the screw causes a very slow movement of the saddle and its rest, and, therefore, when the cut is finished, and it becomes necessary to run back the rest, to commence a new cut, means are required for doing this with rapidity. For this purpose there is a rack attached to the front of the Lathe bed, into which a pinion gears, which has its bearings near the half-nut slides, in the apron of the saddle. The handle to this is the long one seen in front. The half-nuts being opened, to free the rest and its screw, a few turns of the handle carry the tool back again to its starting-point, ready to commence a fresh cut. The Lathes illustrated have friction wheels to the crank axle, which is straight, a slotted crank being attached outside the left standard, and this is worked by an anti-friction chain motion passing to the treadle. The pile of cog-wheels seen in front, twenty-two in all, are for attaching to a stud, on a radial arm, which is mounted concentrically with the screw, and can be clamped in position after the gear wheels are arranged on screw, mandrel, and stud. These are necessary for automatic screw-cutting. It is evident that, with a given set of wheels and pinions—geared, on the one hand, with the mandrel, and, on the other hand, with the screw—any desired rate of speed can be obtained between the two; thus, while the screw makes one turn, and draws the slide-rest and tool $\frac{1}{4}$ in., the mandrel may be made to revolve either once or twice, or a dozen times, according to the sizes of the wheels and pinions used, as will be fully explained in the chapter on screw-cutting. The slide rest can, therefore, be arranged for merely turning a smooth surface—which is, in reality, an infinitely fine screw—or it can be made to travel so fast in proportion to the speed of the mandrel as to cut a coarse spiral.

The tools required are the same as those already described, and either the solid ones can be used, or the cutter bar; but when once set into cut, nothing is needed but to work the treadle, when the tool will be carried along with a perfectly

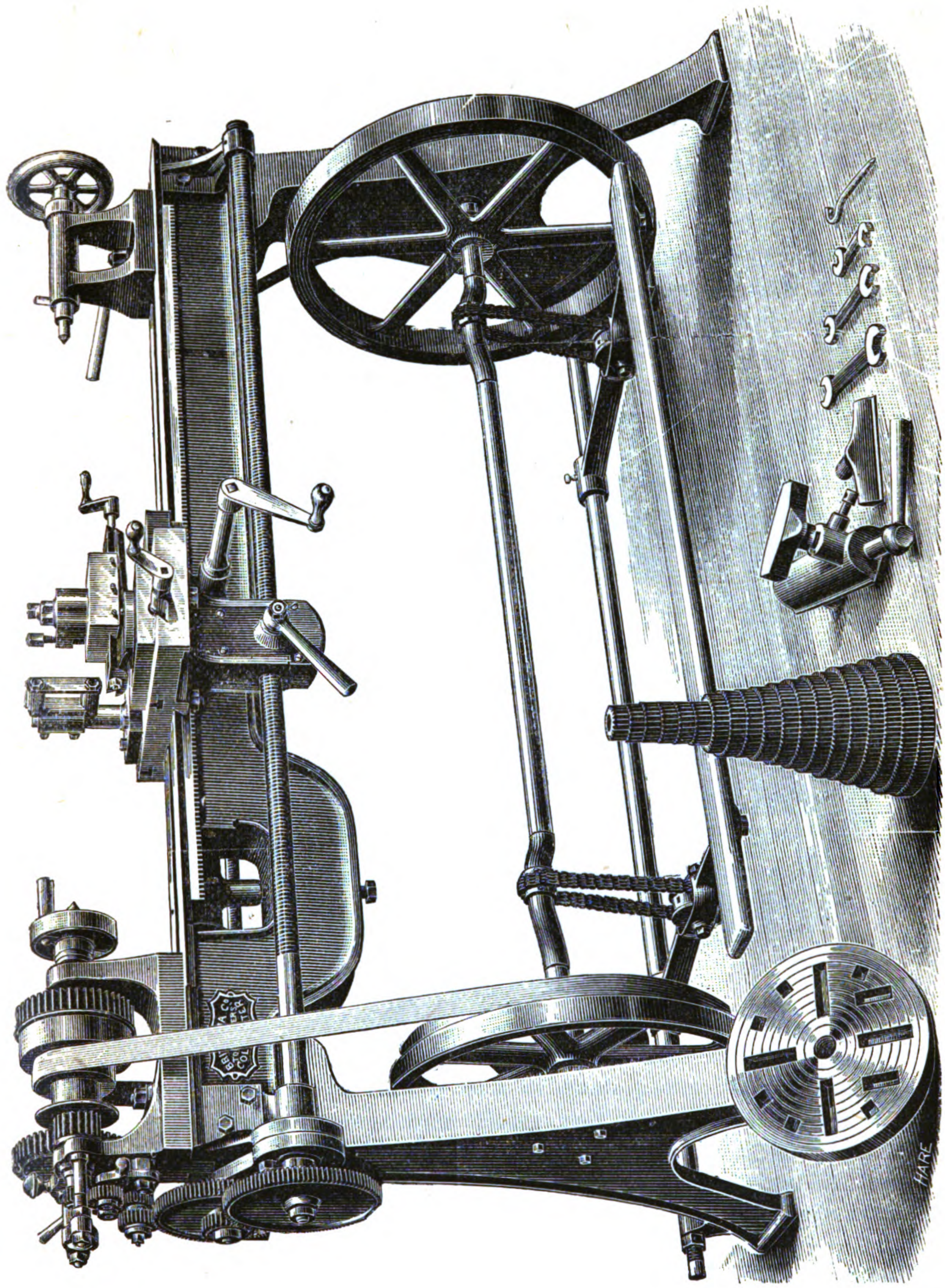
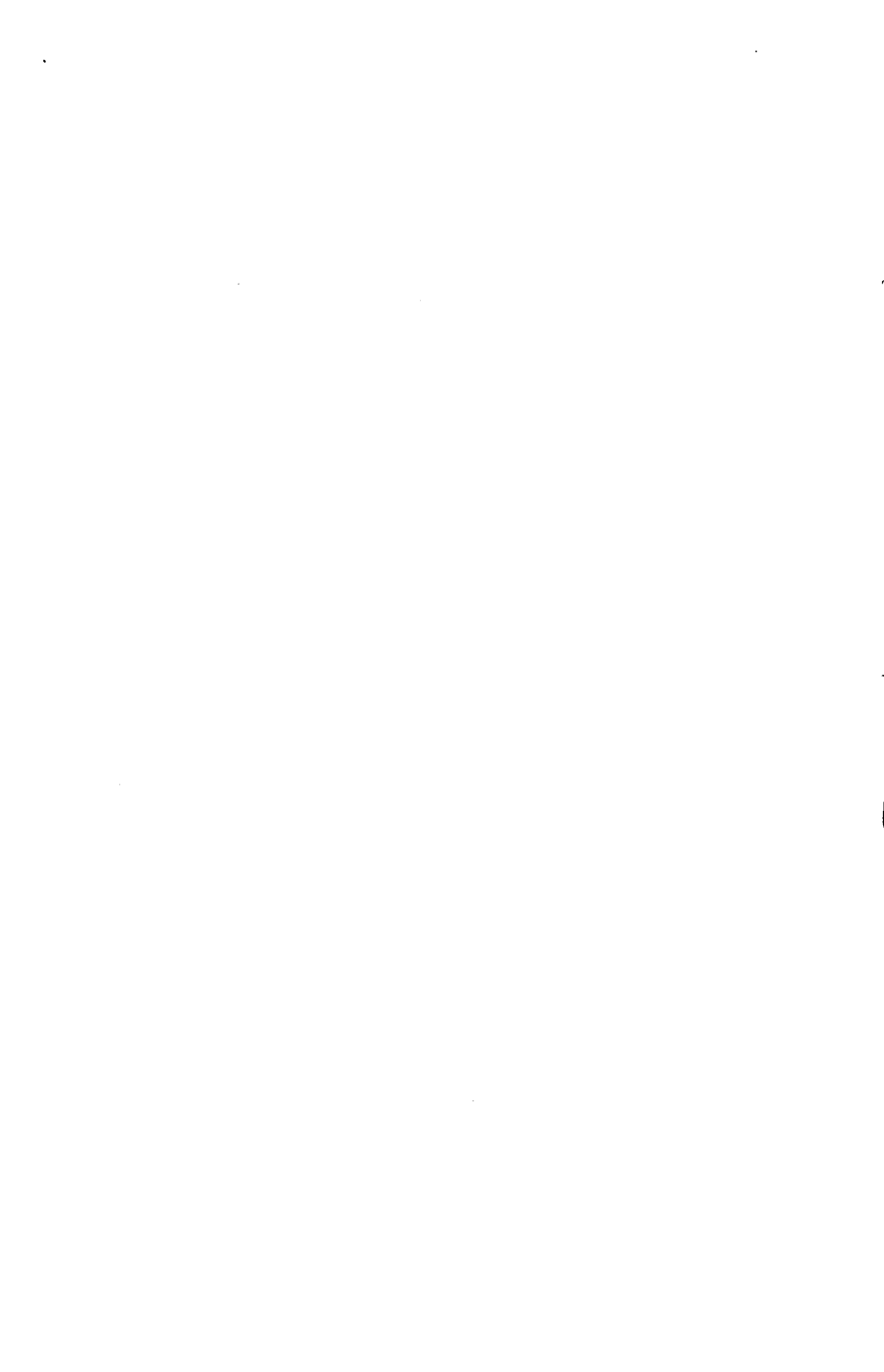

PLATE XII.—LARGE SELF-ACTING AND SCREW-CUTTING LATHE
(No. 16 Lathe, by Britannia Company).



even motion, such as no hand feed can rival. Among Lathe novelties introduced by the Britannia Company, of Colchester, two are well worthy of notice, and they may be taken as extremes of power—viz., their Nos. 13 and 18: the first a small screw-cutting Lathe of 3in. centre only, with 2ft. 6in. or 3ft. bed; and the other a treble-gear Lathe, specially made for the Admiralty for use on shipboard—a Lathe with gap bed, to swing 24in., and with power enough, under treadle

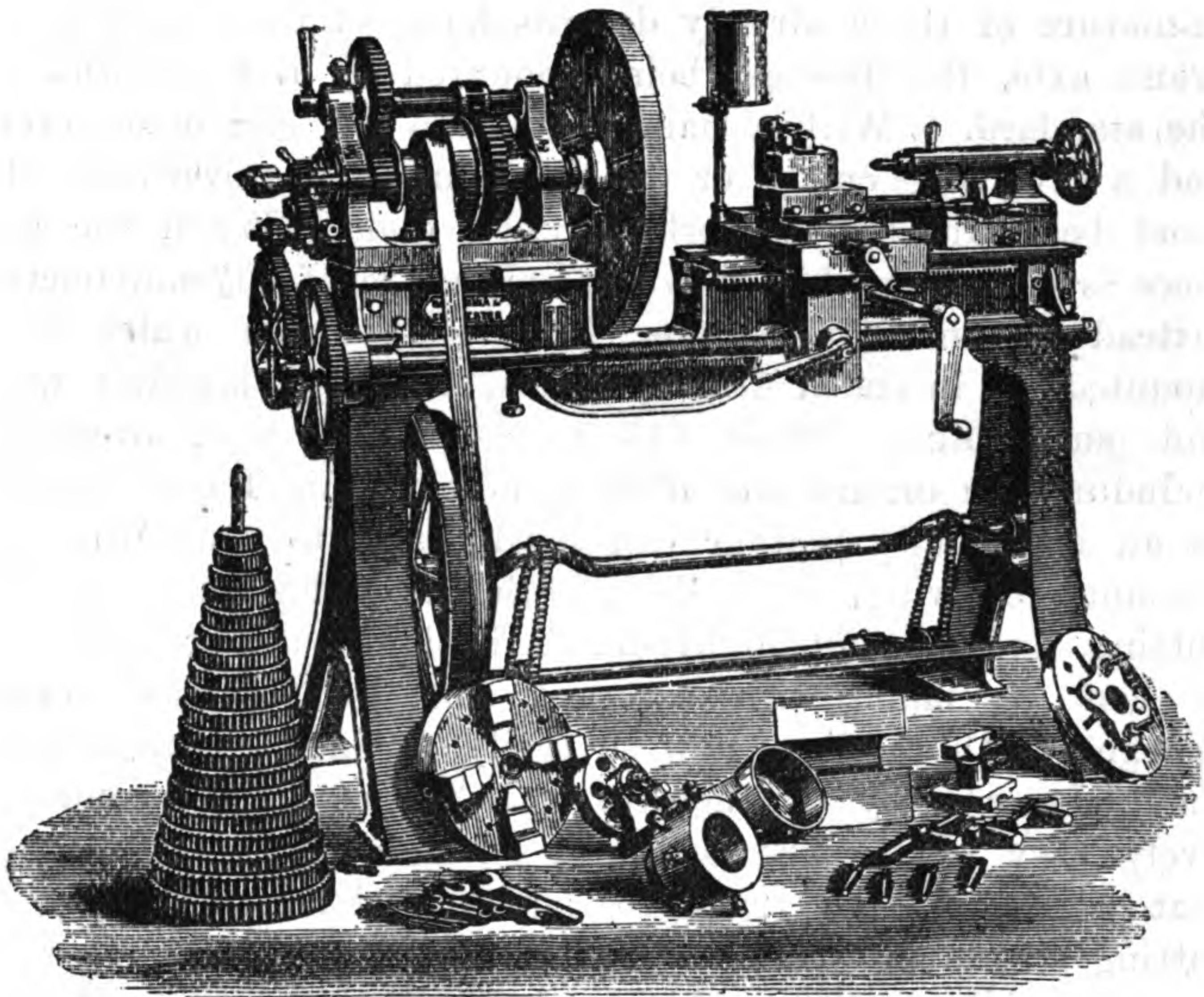

FIG. 21.—TREBLE-GEARED LATHE.

action alone, to take a $\frac{1}{2}$ in. cut off a 2in. or 3in. bar. It would be hard to find a tool of such power more compact, better designed, or better made; and the price—£36 for one of 5in. centre—is marvellously low. That it is possible to turn a pump-cover, or similar article, 24in. diameter, by foot power is, at first sight, incredible; but the treble gear multiplies enormously the power applied. This Lathe is illustrated here in Fig. 21, which gives a good idea of its general

appearance. In a country fitting-shop or agricultural implement maker's where steam is not available, this Lathe would be invaluable.

The No. 13 (*see* Plate XIII.) is the amateur's Lathe *par excellence* for all light work in engineering, such as model-making and the construction of electrical and scientific instruments. Fitted also, however, with overhead, as shown here, it becomes suitable for ornamental and plain turning in wood or ivory. As a screw-cutting Lathe, it is an exact miniature of those already described, except that there is no crank axle, the flywheel being mounted on a fixed stud on the standard. With a handle fitted to the slide-rest screw, and a revolving cutter or drill, driven by the overhead, the most beautiful spiral work can be done. When the gap piece is out of the bed, it will admit a disc of 10½ in. diameter, instead of 6 in. The drawer in the table on which it is mounted is intended for spanners, tommyes, mandrel taps, and such like. Price £15 15s.; or £21 with overhead, including the ornamental drill spindle. This Lathe is such as an ingenious amateur can hardly fail to turn to good account, removing, as it does, both the difficulty of screw-cutting, and also of highly-finished plain turning in metal. It can be made with a crank shaft at a small extra charge. With castings, now so easily obtained, engine-making should become, by the help of this unique Lathe, comparatively easy work. The overhead is, moreover, an advantage that need only be tried to be appreciated, especially in cutting screws in wood. These can be beautifully cut with small, revolving cutters, which make a clean thread far better than is attainable with a fixed tool, owing to the very slow motion of the mandrel, which is not well suited for wood. In fact, wood cannot revolve too quickly against the tool, especially if it is of the kind known as soft wood. A V tool, however, will cut the latter quite cleanly, and make a nice thread, and this can be held in a cutter bar, and fixed on the slide-rest of this Lathe.

It is not to be supposed that the amateur, or anyone not a thorough adept, will succeed in either plain turning or screw-cutting—most decidedly not the latter—merely by

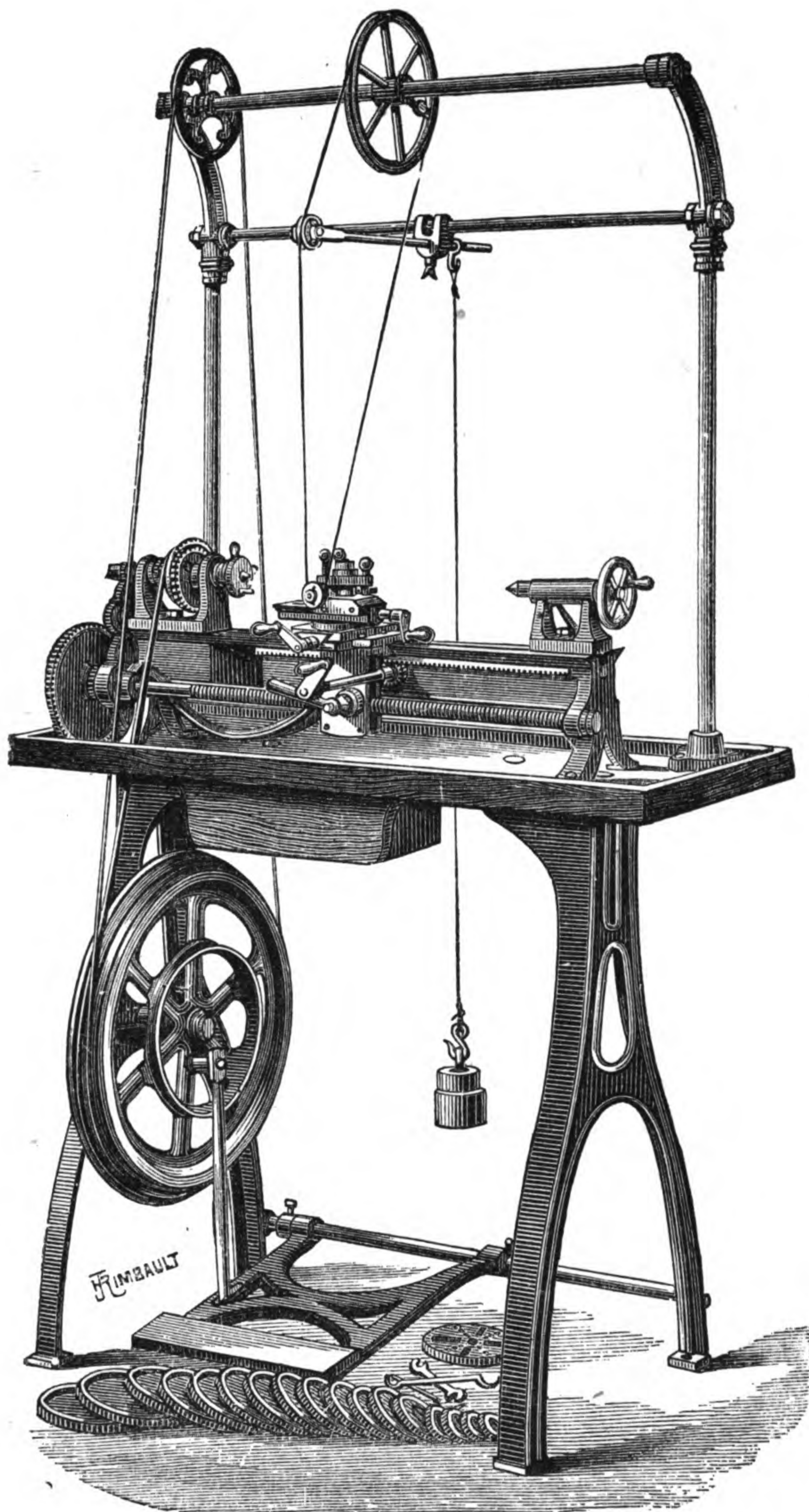
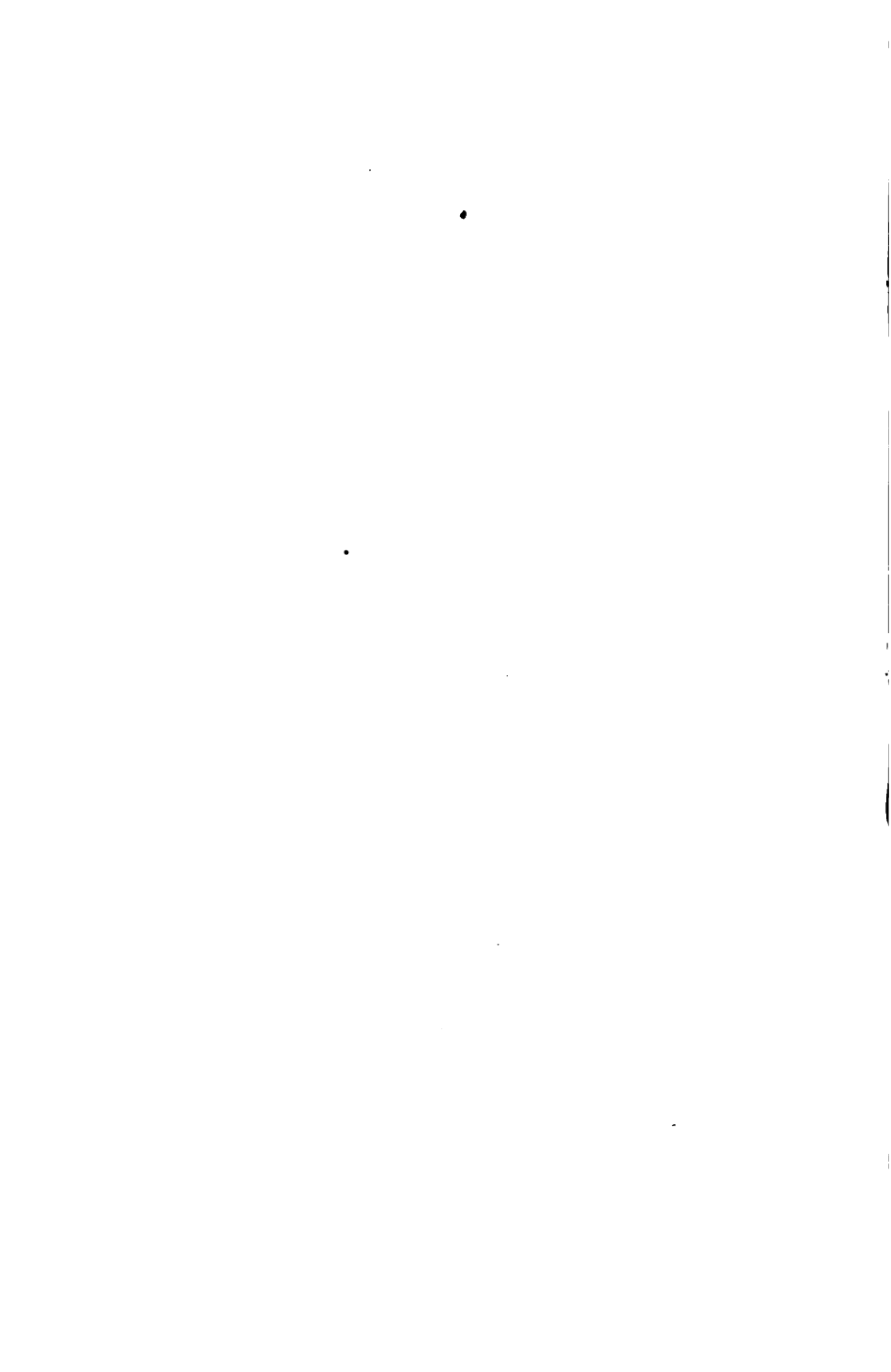

PLATE XIII.—MINIATURE SCREW-CUTTING LATHE.



obtaining one of these handy little machines. A screw-cutting Lathe is a very ingenious bit of mechanism, and its capabilities are not to be learnt in a day. When, therefore, it first comes to hand, it should be thoroughly examined, and its various parts studied until well understood. Let the various wheels be mounted—first, a mere idle wheel, or the stud brought into gear with that or the screw, and with the small one below the two that are on a pivoted plate at the back of the headstock, which two, I have explained, are meant to reverse the motion of the screw for cutting left-handed threads. Then, when the single row of wheels has been thoroughly understood, let the wheel and pinion on the sleeve be mounted on the stud, and the effect of this arrangement tested as regards change of speed. Put a cylinder of wood in the Lathe, to experiment upon; and, with a sharp point tool, try the result of different wheels geared singly and also doubly. This will teach, better than any written description, the nature of screw-cutting, to be hereafter carried out, in metal. It will be found that wheels geared singly—*i.e.*, in one plane—only produce the effect of the first and last; the result, as regards speed, being the same as if these were geared together. But the intermediate one alters the *direction* of motion, and is necessary to fill up the space between the mandrel wheel and that on the leading screw. Any intermediate wheel that is of suitable size may, therefore, be used indifferently, without altering the ratio of speed between the screw and mandrel. In illustration of this, suppose a wheel of sixty teeth on the screw, and one of ten on the mandrel, which is the driver or originator of the motion: it is evident that the rate will be six to one—that is to say, the small wheel will turn six times while the large wheel turns once—and they will turn in opposite directions. Insert between them one of twenty teeth, which will, at the same time, reverse the direction of the driven wheel. The ten wheel (driver) makes one turn, while the twenty on the stud makes *half* a turn—*i.e.*, uses ten of its teeth—and, as six times ten are sixty—the number of teeth on the screw wheel—the latter still makes, as before, six turns, to one of the driver. Instead of an intermediate wheel of twenty cogs, any other

will answer equally well that may be of convenient size. The small wheel under the pair on the plate is of the same size as that on the mandrel, and consequently may be considered the mandrel wheel. Consequently, the wheel placed on its projecting axle may be reckoned as being placed upon the mandrel itself, and is to be considered the first driver of the train. Screw-cutting depends upon the rate at which the slide-rest carrying the tool travels compared with that at which the work revolves. The leading screw is of half or quarter pitch—two or four threads to the inch—the latter in all small Lathes; so that one turn of the screw moves the rest $\frac{1}{4}$ in. along the bed. If the wheels are so arranged, therefore, as to carry the mandrel once round in the same time as the tool takes to travel $\frac{1}{4}$ in., or four times while the tool travels lin., the screw cut will be quarter pitch also—the same as the original leading screw. Here the mandrel and screw make turn for turn, and, therefore, each will need a wheel of equal number of teeth, and to fill up the space, any idle wheel may be placed on the stud.

Plainly, it is not difficult, so long as we can get the proper proportion out of wheels in the same plane, to get any even number of threads to the inch from a leading screw of a quarter pitch. Starting with a pair of the same number of cogs, we have seen that the pitch of the leading screw will be exactly copied. Halve that on the mandrel, and the pitch will be twice as fine, because now the work will turn twice while the screw turns once; and so on—the smaller the mandrel wheel, the greater the number of threads that will be cut in lin. of length. The wheels generally rise by five cogs, from 20, the smallest, to 120, with two of 60 for use to get the equal pitch with that of the screw. It is convenient to keep the one on the screw unchanged, and this is commonly of 60 teeth in small Lathes, which is a convenient size; or, if preferred, that on the mandrel may remain the same, and the screw wheel be the one to change—it is merely a matter of convenience: but, for a time at least, while getting into the way of reckoning, one or the other should be constant. A short Table is annexed, suitable for a 60 wheel on mandrel, unchanged:—

Threads to inch required.	Mandrel Wheel.	Stud Wheel.	Screw Wheel.
1	60	Any of suitable size.	15
2	60		30
3	60		45
4	60		60
5	60		75
6	60		90
7	60		105
8	60		120

And so on for all even numbers, as long as the requisite wheel is in the set, e.g., 24 threads would require four times 90 = 360, which will not be supplied.

But, again, suppose with a 60 wheel we try to find a screw wheel to produce $3\frac{1}{2}$ threads to the inch, we find it would be one with $52\frac{1}{2}$ cogs. We must, therefore, change our 60 mandrel wheel for another—say, of 80 cogs—and with 70 on the screw, the required pitch will be obtained; for 70 bears the same proportion to 80 as $52\frac{1}{2}$ does to 60.

Perhaps the simplest way to get at it is this. Set down the number of threads required, and under it the number of threads to the inch on the leading screw, making it a fraction thus: Required 6 threads to the inch, with a leading screw of 4 to the inch, $\frac{6}{4}$. As we have no wheels of so few cogs, multiply both by the same number—say, 10—we get $\frac{60}{40}$. The bottom figure will be the mandrel wheel, the top one the screw. Both these wheels are in the set. But if we want, instead, to use our 60 wheel on the mandrel, we can manage it, for we have but to multiply the $\frac{6}{4}$ by 15 instead of 10—thus, $\frac{90}{60}$. We now get the 60 on the mandrel, and 90 on the screw, as already set down in the Table. We will now take the fractional pitch, $3\frac{1}{4}$ to the inch. Set it down as before, and multiply by 10, thus $3\frac{1}{4} \times 10 = \frac{35}{4}$; or, if more convenient to use larger wheels, multiply again by 2, and we obtain $\frac{35}{4} \times 2 = \frac{70}{8}$, which is also the same as shown in the table, 80 on the mandrel and 70 on the screw.

When the wheels set in one plane are incompetent to produce the speed required, we have to break up the single fraction into two, and thus get the sizes of the stud wheel

and pinions. I may observe here, that it is of no consequence whether we place the pitch required above or below in the so-called fraction, and for one reason we may perhaps conveniently reverse it in treating of stud wheels. Thus, to cut 6 with a screw of 4 to the inch, $\frac{4}{3} \times 10 = \frac{40}{3}$, or $\frac{6}{4} = \frac{60}{40}$; only we have to remember that the mandrel wheel will be that which we get from the pitch of guide-screw—*i.e.*, in this case, the 40 wheel—a fact easy to remember. To work with the extra wheels, suppose we have to cut 9 to the inch with a screw, as before, of 4, $\frac{4}{3} \times 10 = \frac{40}{3} = \frac{4}{9} \times \frac{10}{9}$. We can multiply $\frac{4}{9} \times 5 = \frac{20}{9}$, which wheels we have at hand, and, as we have a pair of 60, we can multiply $\frac{10}{9} \times 6 = \frac{60}{9}$. We thus get $\frac{20}{9}, \frac{60}{9}$. The top are the drivers, the bottom the driven. So we put 20 on mandrel, driving 45 on stud, on which we also place 60 as driver, and gear it to 60 on the screw. We have worked as before, only we have cut up the one fraction into two. Now, it might have happened that we had but one 60 wheel, in which case, for the sake of practice, we will work differently.

We begin with $\frac{4}{3} \times 10 = \frac{40}{3} = \frac{8}{45} \times \frac{5}{2}$. We may leave the 45 and 5, and multiply the 8 and 2 by 5. We now get $\frac{40}{45}, \frac{5}{10}$, and can again multiply the latter pair by 10, and get $\frac{50}{100}$, or by 6, and get $\frac{30}{60}$. Let us suppose the latter to be found preferable. The whole will stand $\frac{40}{45}, \frac{30}{60}$, and we put 40 on mandrel, to gear with 45 on stud, which also carries 30, to gear with 60 on the screw. To prove it, multiply the drivers together, and also the driven, and the original fraction will recur $\frac{40}{45} \times \frac{30}{60} = \frac{12000}{27000} = \frac{12}{27} = \frac{4}{3}$. Screw-cutting Lathes have attached, generally speaking, a plate, with the numbers engraved, for ordinary Whitworth pitches, to suit the particular guide-screw and set of wheels, rendering calculation unnecessary. But the above has been given to explain the principle, and to enable the workman to calculate for himself in respect of any unusual pitch of screw he may have to cut. It may happen that, with the usual set of twenty-two wheels, it may not be possible to get certain

pitches exactly, and then the nearest that is practicable within a very small fraction must take its place, and will often answer very well for a short length; for the difference in that case will not be perceptible. A nut, *e.g.*, cut with nine threads, may apparently fit a screw of eight or ten, if it has only to go on a few turns. Of course, it is only for such a common, rough job that such fit would pass muster.

The principles here laid down are carried out, in a later chapter, by a practical workman, accustomed to all operations of the kind. A Table is there added, to save, to a certain extent, the trouble of calculation. At the same time, it is of great importance to a latheman to become independent of such Tables, which are rather conducive to laziness. They are, however, useful as a means of checking and verifying calculations previously made by the workman.



CHAPTER VII.

CHUCK-MAKING.

IT will now be as well to fulfil a promise made in one of the earlier pages of this work, by describing the proper method of making a chuck in wood and in metal, because this is a task almost necessary for the amateur, and involves a little screw-cutting, in which he is now supposed to be fairly proficient. To commence with a plain cup chuck of boxwood. Let a piece be sawn from the log, of adequate size, say 2½in. or 3in. in diameter by 3in. in length; care must be taken to saw it off squarely, or there will be unnecessary waste, and boxwood is precious. If a self-centring scroll chuck is at hand that will grasp it, nothing can be more suitable. If not, let a hole be bored centrally, and mount the block on the taper screw chuck. It must bed down fair and true against the plate of the chuck, and be very firmly secured, because it has to stand both turning and boring. Bring up the back centre to help hold it, while the outside is being reduced to a cylindrical surface, and the end cut exactly square to the axis. Of course you can, in this last operation, only carry the cut as far as to the back centre. The poppet head must, therefore, now be removed, and the face of the work finished by means of a chisel, held flat on the rest as before explained; try it with a straight-edge, and see that it is neither hollow nor convex, but truly flat. Now, with a nose bit or gouge, or round-end tool, bore a hole to a depth rather greater than the length of the screw on the mandrel nose; and if the latter is lin. diameter,

let this hole be $\frac{3}{4}$ in., as the thread will be, probably, $\frac{1}{2}$ in. deep; anyhow, don't let it be too large, as it is easy to enlarge it if too small. Here, again, care is needed to prevent the bore from being conical in either direction—it must be quite parallel. An inside tool, or right-hand tool, as it is often called, is the proper one to finish it with. Now bevel slightly, or round off the sharp edge, or “arris,” as directed in the chapter on screw-cutting by hand, which is the next process to carry out; but, unless the turner is an adept at screw-cutting, he had better avail himself of some kind of guide—a traversing mandrel, if he has one; but if not, the best way is to use a special tap, made to cut sharply, so as to make a screw line deep enough to give a lead to the chasing tool. The sort of tap to have is one similar to what is sold with a screw-box. The taps for metal are of no use for this work. The ordinary taper tap will not get a hold, unless you can make the hole a deep one; the plug will not enter, and the intermediate will not have sharp cutting threads near its end. What is needed, and should be sold always with a lathe, is a very short tap, with four sharp edges, and a long stem with a hollow centre made in the end; the cutting part must, of course, taper a little. It is certainly possible to use an ordinary intermediate tap for a cup chuck, because you may bore it as deep as you please; but it is not really suitable. The way to enter it is to bring up the poppet head so that its point may fall into the hollow centre in the end of the stem or shank, a small spanner or hand vice being secured to the square head of the tap, or a proper tap wrench, which is better. The tap is then slowly revolved, a little at a time, while the back centre is screwed up so as to follow it; and this is carried on until the requisite depth is reached. There will now be, on gently withdrawing the tap, by turning it backwards, a clear, sharply-cut screw line, quite sufficient to give a lead to the chaser—and it will be parallel, and true to the lathe centres. The hand rest is now to be set across the end of the chuck, and the inside screw tool is to be gently applied, when its points will be caught at once in the spiral groove, which will carry it forward at the required rate. In this way the thread is to be deepened gradually, until it is

found to be of full depth, and equally cut from end to end of the hole.

To allow of this, it is usual to bore a little deeper than the length of the mandrel nose, and then to take a side parting tool, and with it to cut a groove at the bottom the full depth of the thread. The chaser will then fall partly into this, giving time to withdraw its teeth out of cut, and thus enabling it to cut to the end of the thread without striking the bottom of the hole. Now unscrew the chuck (not the one you are engaged upon), and, turning the latter round, try how it will go on. If it is too tight, do not force it, but put all back, and ease it. The sharp edge of the thread will be better removed, and a chuck should run on quite easily, and bed up well and truly against the face of the mandrel. Try and try again, therefore, until such is the case. All that remains is to screw the wooden chuck in its place on the mandrel, turn up the outside, and bore it out to the size needed; which latter job should be left, of course, until the chuck is actually required for use. It is usual to round off and shape to a nice curve the back end of the chuck, next to the mandrel; but this is a matter of taste. If all has been well done in boring and screwing, the chuck ought, theoretically, to run true at once, when in its place; but this is seldom the case, although the error is often very slight. In any case, a few strokes of gouge and chisel are all that will be needed, and, once true, it will generally so remain for a long time.

To make a similar chuck in metal, the process, roughly speaking, is the same; but here we have to deal with a casting of iron, brass, or gunmetal. This must, of course, be chucked differently, though if of brass, a strong American scroll chuck may possibly suffice; yet it is hardly a safe plan. Preferably I would chuck it *upon*—*i.e.*, outside—a wood chuck, or outside a block of wood driven into a metal cup chuck, and turned to fit it tightly. If it is a good casting, and is mounted to run fairly true, there will be no shocks caused by the tool, even at the first cut—only a steady strain, that should not loosen it, or throw it out of centre. The skin should be ground or worked off with a coarse old

file before mounting it on the lathe, as it will make it much easier for the tool to face it up. Such skin is often exceedingly hard, and will instantly take off the edge of a tool; the latter, however, should always have a clean place to start upon, by filing off the edge of the work to form a slight bevel—it then gets at once underneath the skin. There are face-plate clamps which will also serve our purpose, but on the whole the plan suggested will be the simplest, and therefore the best. The chuck to be turned need not occupy more than an inch of the block on which it is mounted, if it is well fitted. Being rough inside, it will take a secure hold of the wood. The great thing is to drive it on carefully and truly at once, so as not to have to keep on tapping it this way and that, to set it correctly, or it will be loose on the block, and yield to the tool. Supposing the work fairly mounted, a cut should be taken, all over it, either by hand, or, better, by a tool in the slide-rest; a round-end will be the usual one. Then, the end that has to be bored is to be very truly faced; and, if the hole is not cored out in the casting, it will have to be drilled—and in a cup chuck it is generally drilled quite through into the hollow of the chuck. It is not easy to make a 3in. chuck solely by hand, but as regards boring out the hole for the screw no turning is necessary. If not cored out, a little centre hole is first made, by the point of a graver, and then a drill is run in, and the bore enlarged by another; or a little recess is turned, and then a half-round engineer's bit of the exact size needed, bores and completes the hole at one operation. This tool has a centre drilled at its opposite end, and is always advanced into cut by the screw of the back centre. It is a splendid tool if well made, and will cut a clean hole in solid iron; but it will save it to run a drill in first. You must turn a slight recess, however, just to insure a true start. The tap now comes into operation as before, and here again it needs one made sharp to cut a clean line, but a tap a good deal less in size than the mandrel nose, as it will be followed by the chaser, as in the case of the wood chuck. The chief thing is to keep the tap in line with the mandrel, and this is se-

cured always by advancing it by means of the back poppet centre.

All taps of the size of a lathe mandrel have centres left, and are so used in lathe-work. Generally speaking, the screw on the mandrel is not cut clean up to the shoulder against which the chucks abut, and therefore, after finishing the screw to a nice fit as far as it will go, two or three threads must be turned off. It will then bed correctly home, and also run fairly true. As soon as it does this, finish the outside while it is in its place, and, if you like, turn the inside out quite smooth, and *very* slightly taper—so slightly as to leave it almost cylindrical. Such is the proper, orthodox, and best way; but a great many chucks are mounted in the lathe and bored, and then, if a through or thoroughfare hole is allowable, as in the present case, the entire thread is done with ordinary taps, and the chaser wholly dispensed with. It is then screwed on the mandrel; and, as it is rarely that it can run true, the outside is freely cut away to make it run correctly. If the end does not touch the shoulder of the mandrel all round, it is filed till it does, and the result is a badly-fitted chuck, that will again and again work out of truth.



CHAPTER VIII.

TURNING ARTICLES OF SQUARE SECTION.

IT would at first sight be deemed impossible to turn articles in an ordinary lathe of any other form than cylindrical, although, by means of rocking headstocks, actuated by rosettes, or cams, or special appliances, such work is done every day, and wheel spokes, axe handles, and other irregular forms, are shaped by thousands. Nearly a century ago nevertheless, Bergeron published a method of effecting such work by the aid of a sort of chuck, round the periphery of which several bars of material were mounted, so that they might come in succession under the operation of the gouge and chisel. The method was precisely similar to that now to be explained, the chuck and its fittings being, however, improved and simplified. The apparatus is very cheap, and the work produced sufficiently satisfactory to be worth doing. There is also the advantage of being able to make from four to six articles at once, and precisely similar. The apparatus consists: first, of a square bar of iron, with centres drilled at the ends, to be mounted as if for turning. Upon it are fitted a pair of round discs of wood, which can be adjusted at any desired width apart, according to the length of the work. These are backed by smaller flanges of metal, which secure them to the bar by a wedge or screw. In the edges of the wooden discs are cut rectangular notches, to fit the bars of wood which are to be turned. The latter are secured, either by such iron clamps as are shown, or by any other efficient means, such as an iron hoop

slightly larger than the discs, and thin wedges of hard wood.

Whatever may be the mode adopted, it must be capable of easy removal and readjustment. The drawings given, of the

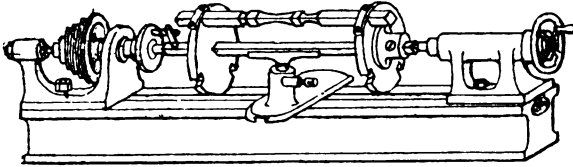

FIG. 22.—TURNING ARTICLES OF SQUARE SECTION.

complete apparatus and its essential details (Figs. 22 and 23), will suffice to explain clearly the arrangement. The square bars thus mounted can now be moulded by turning tools held upon the rest as usual; but as they do not themselves revolve,

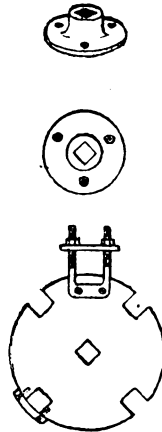

FIG. 23.—CHUCK FOR ARTICLES OF SQUARE SECTION.

except upon an axis common to all, the tools will only reach a small part of their respective surfaces, three-fourths remaining untouched. The bars are now loosened and remounted, with another side outwards, which will enable another fourth

of the surface to be cut, the mouldings running into those previously made. Again the bars are loosened, and the process repeated, and after three readjustments the several bars will be found to have obtained a form of which the cross-section is apparently a square. The faces are, in point of fact, not quite flat, but curved, approaching nearest to a flat if the discs of the chuck are of large size.

This method is also capable of producing work of triangular section, the only alteration requisite being triangular instead of square notches in the discs of the chuck. The work also, or, at any rate, its extreme ends, must be carefully planed with three flat faces, to fit these notches. Other sections, such as octagon, hexagon, or quasi-elliptic, are possible, by different forms of notches to receive the ends of the rods; and, instead of four only, several pieces may be secured and turned at the same time. This kind of work looks very well associated with that of circular form. The top of a candlestick, for instance, may be made cylindrical, and the stem and base, or stem alone, square or triangular. The whole will also stand conspicuous as a turner's puzzle. A half-crown will purchase the whole apparatus, so that it is within the reach of all. This work requires care and sharp tools, taking very light cuts; and in making the discs, it is essential that the notches stand opposite each other. The two should, in fact, be clamped together, so as to enable the pair to be notched as one. Even the square bar may be of wood—so that the whole apparatus might be home made; or it may be purchased, either in the rough parts or finished, of the Britannia Company.



CHAPTER IX.

SCREW-CUTTING BY SELF-ACTING LATHE.

WITH many amateurs it is a source of much perplexity how to manipulate the change wheels and leading screw of a screw-cutting lathe, in order to produce a screw of any desired thread, or "pitch."

It is therefore proposed in this short chapter to present the matter in a very plain and simple manner, which will elucidate the whole mystery.

What we have to do is to traverse the tool along the work revolving between the lathe centres, at such a ratio to the speed of the revolution as shall produce a screw of the desired fineness or coarseness, which is called the "pitch," and usually expressed as of so many threads to the inch in length of screw.

Now it will be obvious that if equal-sized wheels be used to connect the spindle of headstock and the leading screw which traverses the saddle, and with it the cutting tool, along the lathe bed, the speed of the revolution of the spindle (and with it the work driven by it) will be the same as that of the leading screw, and the screw produced will be precisely a counterpart in pitch to the leading screw; and as this may be often required, every set of change wheels is supplied with one pair of equal wheels, usually forty or sixty teeth, and to vary this ratio of speed the other twenty wheels are required.

Our object now is to see how to adjust these various wheels, so as to traverse the tool in such a relative speed to the speed

of the revolution of the headstock spindle as shall cut our desired pitch.

A modern screw-cutting lathe is usually provided with a fixed pinion on the tail end of the spindle, and a second precisely similar pinion on a fixed stud screwed into the headstock below it; and these are geared together by a third and intermediate wheel of the same or any convenient size; while a fourth wheel, precisely a counterpart of the third, is fixed to gear into it, and is running idly so long as the third is being used, but may be brought into gear with the head pinion by disengaging the third, and will thus reverse the motion of the second pinion. These three wheels, which we have called the second, third, and fourth, are fixed on a plate, swivelling on the stud of the second for a centre, and are called the reversing gear, and are used for the purpose of causing the leading screw to revolve in one direction or the other, to traverse the saddle from right to left, or *vice versa*, and thus to cut screws either right or left handed.

Now, as the pinion on the end of the spindle, and that (the second) on the fixed stud below it, are precisely the same, it follows that they will revolve at the same speed, and we may treat them as the same, and the sleeve connected to pinion on stud of reversing gear is now a correct substitute for the spindle of headstock, and in all our subsequent arrangements we shall treat it as the latter, and speak of it as the "spindle."

This sleeve, fixed to and revolving with the second pinion, is prepared with a key to receive the change wheels; and when we say we put such a change wheel on the spindle, we intend putting it on this sleeve.

Now, we have at our disposal for change wheels the "spindle," and the end of the leading screw, similarly prepared with a key for the wheels, and which we will more briefly speak of as the "screw."

But as these two revolve on fixed centres, we must have some adjustable means of connecting them by gearing, and this gearing, we have seen, must vary greatly to produce the results we desire; hence the use of the swing frame, or quadrant plate, which swivels at the end of the screw, and is provided with one or two slots, having a stud and sleeve long

enough to admit of two wheels side by side, and adjustable along this slot. By this means, and the swivelling motion of the swing frame, it will be found that any gearing may be arranged to connect the spindle and the screw.

The sleeve revolving on the sliding stud of swing frame is called the "stud," and the driven wheel on it is called the stud wheel; and should there be occasion to use a second wheel on this sleeve, it would be called the "pinion." So we now have—

Spindle Stud Pinion Screw

or, as they are frequently called—

Driver Driven Driver Driven

We have now to consider the changing of the wheels on these three centres, to give the requisite ratio of speed between spindle and screw.

For simple pitches below twelve threads per inch, a single train of wheels—that is, three—only is needed, viz., one driver, on the spindle; one driven, on the screw; and one intermediate wheel, on the stud. Let it always be borne in mind that a mere idle or intermediate wheel, simply conveying motion, does not affect the ratio. Now the size of the change wheels, that is, the number of teeth, must always bear the same ratio as does the screw to be cut to the leading screw of the lathe; hence we will adopt the following:

Rule 1.—Place the pitch of the leading screw as numerator, and the pitch of the screw to be cut as denominator, in the form of a simple vulgar fraction; multiply both by 5 or 10, and the products will be the wheels required, the numerator being the spindle wheel, or driver, and the denominator the screw wheel, or driven.

Example.—To cut a screw of seven threads per inch with a leading screw of four threads per inch.

$$\left. \begin{array}{l} \text{Leading screw} \\ \text{Screw to be cut} \end{array} \right\} \frac{4}{7} \times 5 = \frac{20}{35} \left. \begin{array}{l} \text{Spindle or driver} \\ \text{Screw or driven} \end{array} \right\} \text{ wheels required.}$$

To cut a screw of twelve threads per inch, with a leading screw of two threads per inch:

$$\frac{2}{12} \times 10 = \frac{20}{120} \text{ wheels required.}$$

Or, if the pitch required be fractional, all we have to do is to reduce the fraction or mixed number to a whole number for a simple denominator, and proceed as before.

Example.—To cut a screw of four and three-quarter threads per inch, with a leading screw of four threads per inch:

$$\frac{4}{4} \times 4 \text{ (denominator of fraction)} = \frac{16}{16} \times 5 = \frac{80}{16} \text{ wheels required.}$$

Pitches above twelve per inch may require, for convenience of gearing or bringing the sizes within the compass of the wheels usually supplied, that a double train (four wheels) be used—usually termed compounding; to effect which we will adopt

Rule 2.—Proceed according to Rule 1, setting forth the ratio of screw to be cut to leading screw in simple fractional form; then assume any two other equal wheels, for second driver and driven, also set forth in fractional form, and divide one driver and one driven by any convenient divisor to bring the figures within the compass of your wheels.

Example.—To cut a screw of twenty-five threads per inch, with a leading screw having four threads per inch:

$$\frac{4}{25} \times 10 = \frac{40}{250}; \text{ assume } \frac{100}{100};$$

divide one driver and one driven by five, and we have

$$\frac{40}{50} \frac{20}{100}, \text{ the four wheels required.}$$

Again.—To cut twenty-two threads per inch, with a leading screw of two threads per inch:

$$\frac{2}{22} \times 10 = \frac{20}{220}; \text{ assume } \frac{100}{100} \div 4 = \frac{20}{25} \frac{25}{100} \text{ wheels required.}$$

Again.—To cut nineteen threads per inch, with a leading screw of four threads per inch:

$$\frac{4}{19} \times 10 = \frac{40}{190}; \text{ assume } \frac{100}{100} \div 2 = \frac{40}{25} \frac{50}{100} \text{ wheels required.}$$

It need only be added, that if any mechanical difficulty arise in gearing any wheels, when once the correct ratio is established, any drivers or driven may be subjected to addition, subtraction, multiplication, or division, without affecting the result, so long as the ratio is maintained.

Thus: $\frac{40}{60} + \text{a quarter} = \frac{50}{72}$, will be the same.

or $\frac{40}{72} - \text{a third} = \frac{40}{90}$ " "

or $\frac{20}{30} \times 2 = \frac{40}{60}$

or $\frac{12}{24} \times 3 = \frac{36}{72}$

or $\frac{20}{120} \div 3 = \frac{20}{360}$, &c., &c.

In order to insure the tool dropping into the same track at each cut, the simplest way is to mark a stop on the bed, or, better, put a stop of wood, or anything convenient, abutting against the front of the poppet, to bring the saddle back to at each cut.

When commencing, have the saddle up to this stop, the nut closed on screw, and all ready to start the first cut. Carefully mark the position of both spindle and screw by chalking the wheels; then proceed.

When the cut is taken, withdraw the tool and disengage the nut; run the saddle back to the stop; turn the lathe till both spindle and screw come to their marked position; close the nut; advance the tool, and it will drop into its correct track for the next cut.

This precaution is not necessary in simple pitches either the same as or multiples of the pitch of leading screw, in which cases our tool will drop into its place correctly without trouble.

In setting up the tool to start each fresh cut, be careful not to be too eager to get the work done, and spoil all; but take just so deep a cut as will best and quickest do the work.

In this adjustment of the tool, the rough-and-ready method prevailing among workmen is to chalk the collar of the slide screw and its bearing, and after withdrawing the tool at the end of each cut by means of the slide screw, to set it up for the next to the chalk mark of the last cut, and so much more

of a revolution of the slide screw as practice shows will give the requisite depth of cut; then wipe out the last chalk mark, and mark afresh. But this method lacks science and system, and is, after all, but a rough method, constantly liable to variation of depth of cut.

To better insure accuracy in this matter, the Britannia Company have patented a little appliance which they call a micrometer. It is made to apply to any ordinary lathe, and consists of a small frame, or bed, attached in a minute to the saddle, and carrying a carefully-cut screw of ten threads per inch, with a collar again divided into ten parts, and a milled head for turning it by thumb and finger. On this is a nut, which can thus be advanced or withdrawn to any desired fixed distance, correctly indicated by the index point of the frame, and read off the graduated collar of the screw. A stop pin is fixed into the transverse slide of the saddle,

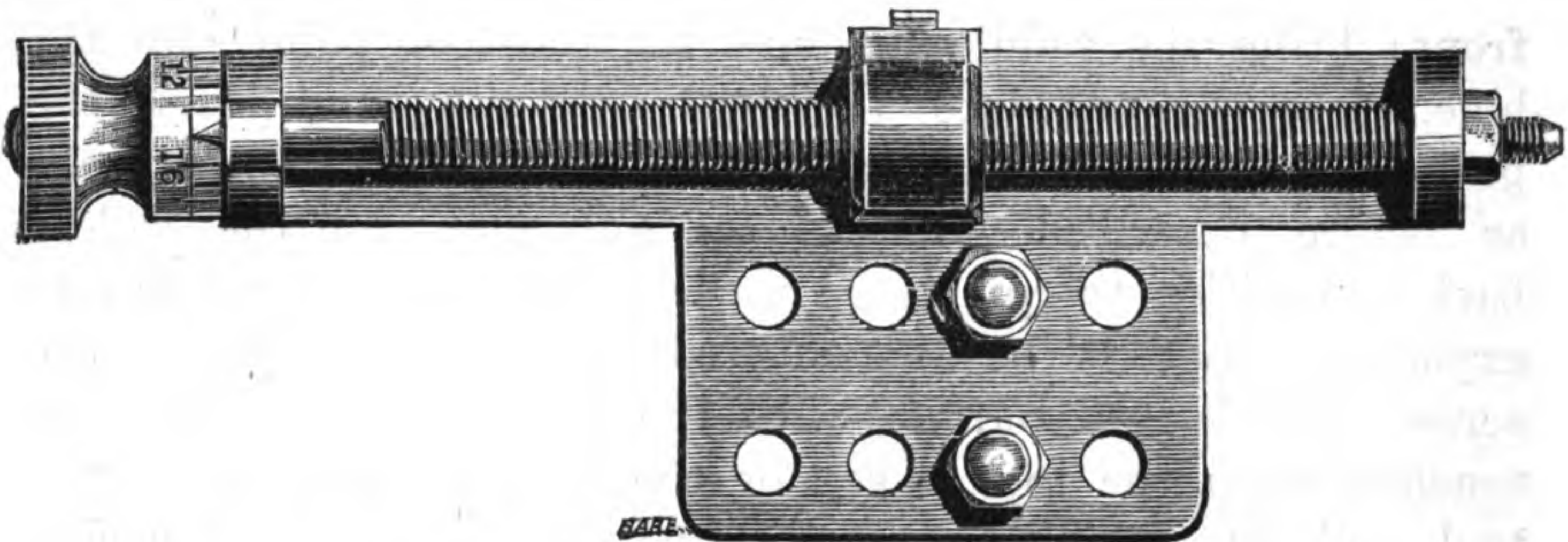

FIG. 24.—BRITANNIA COMPANY'S PATENT MICROMETER GUIDE.

and the nut brought up to this pin; and thus the exact position of the slide, and the tool it carries, is correctly indicated, and any required advance of the tool for a new cut is measured by turning the screw such portion of its revolution as may give the required depth to the one-hundredth part of an inch. It is adapted for inside or outside screw-cutting; and, while one cut is in progress, the tool can be accurately adjusted for the following cut. It can also be applied to any lathe with a slide-rest—for accurately measuring the cut, and so insuring uniformity; and for ornamental drilling and fluting.

For the guidance of the novice, a few useful hints in preparing his work for screw-cutting are added.

He will, by this time, have carefully read and put into practice the operations set forth in Chapter VI., and will be able to turn—or, in workshop parlance, “slide”—a parallel shaft. We will assume this has been done, and it is now desired to cut a thread on the same. When it is practicable, turn the shaft down to the depth of the thread, at the part where the screw will end (as the shank of a tap is), that the tool may run off. But this cannot always be done; the thread may have to end abruptly at a given point, in the full diameter; in this case it is usual to drill a small hole for the tool to run into, and it is safer to stop the lathe about a turn or half a turn before reaching the end, and pull round the rest by hand. In starting a thread to end thus, the work will be set between the centres, with carrier on, and driver of lathe touching, hole for end of thread to front; bring the saddle up, and set the tool point into the hole, close the nut into the leading screw, and mark the position of both spindle and screw, by chalking the wheels, as before described. Release the nut, and run the saddle back to position to commence the cut, and proceed as already explained. Let it be remembered that the handle of the screw of slide-rest, *parallel* with the lathe bed, must not be touched when the tool is set, or the relative position of the tool and nut, which has just been obtained, will be varied. Where a screw has to be cut close up a collar or shoulder a hole may be drilled, or a groove to depth of thread may be permissible for the tool to run into; but the latter is generally objectionable, as it weakens the screw. When both ways are objected to, the lathe must be stopped about a thread from the end, and pulled round the remainder by the left hand, the right hand meantime gradually withdrawing the tool. Practice will soon give the necessary skill for these operations.

The greatest care is necessary to set the tool exactly at right angles to the axis of the work, in order that the thread shall be upright, not sloping like saw teeth, or when the screw and nut are cut, though both of one diameter and

pitch, they will not fit each other. And in grinding the tool, in the case of Whitworth V-shaped threads, see that the correct angle of 55° is maintained. In V threads it is not usual to give the tool any rake or slope; but clearance is necessary, or the under part of the cutting point of the tool may scrape and spoil the thread. But in cutting square threads, especially if coarse or double threads, it is necessary to form the tool with a rake or slope, to follow in the space cut by the edge, either inclining to right or left, as the case may be. To get the correct angle of this rake, draw a right-angled triangle, having the pitch for a base, the circumference of screw for perpendicular, and the hypotenuse will then be the required angle. For all the above purposes, a very useful little gauge is sold, invaluable to screw-cutters, costing only about 3s. It may be observed, that in square threads the depth is usually half the pitch of thread.

Appended are some calculated tables of change wheels which may save time and trouble. To these we have already referred on page 95, pointing out the use or abuse of them. They are certainly an assistance to a young workman, enabling him to set the proper wheels for the job in hand, and to go confidently to work. But if, on trial, some error is found to exist, he will probably be unable to rectify it, and his work may prove to be spoilt, just as it was almost finished. It is a better plan, even where such tables are hung up in a workshop for reference, to make an apprentice work the sum first of all, and then compare the result with the figures given—he will soon find himself independent of such aid, and will leave the tables for those too lazy or too indifferent to make the calculations for themselves.

TABLES OF CHANGE WHEELS.

I.—*Leading Screw having Two Threads per Inch.*

No. of Threads per in.	Drivers.		Driven.		No. of Threads per in.	Drivers.		Driven.		
1	40	—	—	20	7	20	—	—	70	
	50	—	—	25		30	—	—	105	
	60	—	—	30		30	40	—	60	70
1½	40	—	—	25	8	20	—	—	80	
	30	40	—	15		25	—	—	100	
						50	20	—	40	100
1½	40	—	—	30	9	20	—	—	90	
	40	60	—	90		20	50	—	75	60
	40	50	—	25		20	100	—	75	120
1½	40	—	—	35	10	20	—	—	100	
	20	40	—	20		20	40	—	50	80
						30	40	—	75	80
2	40	—	—	40	11	20	—	—	110	
	60	—	—	60		20	50	—	100	55
						20	40	—	55	80
2½	40	—	—	45	12	20	—	—	120	
	20	80	—	30		20	25	—	50	60
						20	50	—	100	60
2½	40	—	—	50	13	20	25	—	65	50
	20	90	—	30		20	30	—	65	60
						20	50	—	65	100
2½	40	—	—	55	14	20	30	—	60	70
	60	40	—	30		20	50	—	100	70
						20	60	—	120	70
3	20	—	—	30	15	20	40	—	50	120
	40	—	—	60		20	30	—	50	90
	25	40	—	20		20	60	—	90	100
	50	40	—	30		100				
3½	20	—	—	35	16	20	50	—	80	100
	40	—	—	70		20	25	—	40	100
	20	80	—	40		30	25	—	60	100
4	20	—	—	40	17	20	50	—	85	100
	40	—	—	80		20	25	—	50	85
	20	60	—	30		20	60	—	85	120
5	20	—	—	50	18	20	40	—	80	90
	30	—	—	75		20	50	—	120	75
	40	—	—	100		20	60	—	120	90
	25	60	—	75		50				
6	20	—	—	60						
	20	50	—	40						
	50	40	—	75						

No. of Threads per in.	Drivers.			Driven.		No. of Threads per in.	Drivers.			Driven.	
				
19	20	40	...	80	95	28	20	30	...	105	80
	20	50	...	95	100		20	45	...	105	120
20	20	40	...	80	100	30	20	25	...	70	100
	20	60	...	120	100		20	30	...	90	100
21	20	25	...	75	70	32	20	25	...	75	100
	20	30	...	90	70		20	40	...	100	120
22	20	40	...	80	110	34	20	25	...	80	100
	20	30	...	120	55		20	30	...	80	120
23	20	50	...	115	100	36	25	30	...	100	120
	20	60	...	115	120		20	30	...	85	120
	20	45	...	90	115	20	25	...	85	100	
24	20	40	...	80	120	38	20	25	...	90	100
	20	30	...	80	90		20	30	...	90	120
	20	45	...	120	90	20	25	...	95	100	
25	20	30	...	75	100	40	20	30	...	100	120
26	20	30	...	120	65	48	20	25	...	100	120
27	20	40	...	120	90	60	20	30	...	120	150
	20	25	...	75	90						

II.—*Leading Screw having Four Threads per Inch.*

1	80	—	...	—	20	2½	80	—	...	—	55
	60	100	...	30	50		40	50	...	25	55
	50	120	...	20	75		50	80	...	110	25
1½	80	—	...	—	25	3	60	—	...	—	45
	40	80	...	20	50		40	—	...	—	30
1½	80	—	...	—	30		3½	50	40	...	20
	40	120	...	30	60	40		—	...	—	35
	40	90	...	30	45	60	50	...	35	75	
1½	80	—	...	—	35	4	80	50	...	35	100
	40	80	...	20	70		40	—	...	—	40
	60	80	...	20	105	60	—	...	—	60	
2	40	—	...	—	20	5	40	—	...	—	50
	50	—	...	—	25		60	—	...	—	75
2½	80	—	...	—	45		60	30	...	25	90
	40	80	...	60	30	6	60	—	...	—	90
2½	80	—	...	—	50		30	—	...	—	45
	40	90	...	30	75						
60	90	...	45	75							

TURNING LATHES.

No. of Threads per in.	Drivers.		Driven.		No. of Threads per in.	Drivers.		Driven.				
7	40	—	...	—	70	22	20	—	...	—	110	
	20	—	...	—	35		20	40	...	55	90	
	45	80	...	90	70		20	50	...	55	100	
8	20	—	...	—	40	23	20	—	...	—	115	
	30	75	...	45	100		30	60	...	115	90	
	30	80	...	60	90		30	80	...	115	120	
9	20	—	...	—	45	24	20	—	...	—	120	
	30	80	...	60	90		25	40	...	75	90	
	30	40	...	60	45		25	20	40	...	50	100
10	30	—	...	—	75	20		60	...	75	100	
	40	—	...	—	100	26		20	40	...	65	80
	30	40	...	60	50		20	35	...	65	70	
11	20	—	...	—	55		20	40	...	60	90	
	30	40	...	60	55	20	80	...	90	120		
	12	20	—	...	—	60	20	70	...	90	105	
30		50	...	45	100	28	20	60	...	70	120	
13		20	—	...	—		65	20	40	...	70	80
	25	40	...	50	65		30	40	...	80	105	
	14	20	—	...	—	70	30	20	40	...	60	100
20		50	...	35	100	30		40	...	100	90	
20		60	...	35	120	20		50	...	75	100	
15	20	—	...	—	75	32	20	30	...	80	60	
	30	40	...	90	50		20	60	...	80	120	
	16	25	—	...	—		100	25	40	...	80	100
30		50	...	60	100	34	20	50	...	85	100	
17		20	—	...	—		85	25	40	...	85	100
	35	40	...	70	85		30	40	...	85	120	
	18	20	—	...	—	90	36	25	40	...	90	100
30		40	...	60	90	30		40	...	90	120	
25		40	...	45	100	38		25	40	...	95	100
19	20	—	...	—	95		30	40	...	95	120	
	25	80	...	100	95		40	20	40	...	80	100
	25	40	...	50	95	20		30	...	75	80	
20	20	—	...	—	100	48		20	25	...	75	80
	25	40	...	50	100		25	30	...	75	120	
	25	60	...	75	100		60	20	25	...	75	100
21	20	—	...	—	105	60		20	25	...	75	100
	20	40	...	70	60							

CHAPTER X.

USES OF THE OVERHEAD.

A BOOK on the Lathe would hardly be complete without an explanation of that attachment briefly called "The Overhead." There are many forms of this, but that shown on the miniature screw-cutting lathe (Fig. 13, page 89) is as good as any other, and is the plan most commonly adopted. The main object of it is to enable a turner to connect the movement of the fly-wheel with the slide-rest, or with various pieces of apparatus held therein, such as drills and revolving cutters. The screw of the slide-rest may also be itself so connected, which will render it self-acting, thus imitating, in a small way, the large screw-cutting lathes. For this purpose the winch handle is removed, and replaced by a pulley of any desired size. The overhead consists of a revolving shaft, supported on a pair of light but firm standards, attached to the backboard of the lathe. Upon this shaft is a pulley like that on the mandrel, and a roller, or second adjustable pulley. A cord from the fly-wheel, or sometimes from the mandrel, passes over the first of these, and a second cord descends from the roller to the pulley of the slide-rest screw, or to that of the drill, or of any revolving cutter which may be in use. It will evidently be necessary to keep this cord tightly strained under all circumstances, whether the driving pulley of the apparatus be large or small, and whether it is advanced nearer to the work or withdrawn by the action of the cross slide of the rest. To attain this end, there is a bar just under the shaft of the overhead,

acting partly as a tie-bar between the standards, but, secondly, as a support to a sliding block, capable of being placed at any part of the bar, about which, also, it can turn as a hinge. Through this block passes a round rod, of stout iron, which carries at one end a pair of pulleys, whose peripheries bear against the cord, the pressure depending upon a weight slung to the opposite end of the bar, as well as upon the leverage. For this reason, the entire affair is called the "tension apparatus." Sometimes a spring arrangement takes the place of the weight; but the latter, being constant in its action, is decidedly preferable, and if it is suspended near the floor there is nothing objectionable about it.

The principle of the overhead having been explained, it will be as well to enter briefly upon some of its uses, although we do not intend to set forth *in extenso* the details of ornamental turning, which, indeed, require an extra volume.

Let us suppose a drilling spindle securely held in the rest, having a round-ended drill in its socket, such drill pointing to a smooth cylinder of boxwood held between centres or in a chuck. Let the height of drill be level with the lathe centres. Now suppose the ordinary lathe cord removed, and that from the fly-wheel to the overhead to be arranged, and a second cord to lead down from the overhead to the driving pulley of the drill. If, by means of the cross slide, the drill is advanced, it will simply bore a hole through the cylinder. But now let us suppose that the cross slide advances the drill only about $\frac{1}{10}$ in., while the other handle of the rest is steadily turned, so as to carry the entire drilling apparatus horizontally along the work, lengthwise. In this case, the result will be a rounded groove, or recess, or *flute*. The mandrel, it will be observed, is not revolving at all, because its cord was removed. In practice it is held fast by an index point, resting in one of the holes of a division plate fixed to the face of the mandrel pulley; the circles of holes for this purpose are, however, very frequently drilled in the face of the pulley itself. By these means we can advance the pulley as many divisions as we please between each traverse of the drill, and make the flutes as near to each other or as far apart as we please.

Now let us substitute for the round-ended drill one with a semicircular hollow at the end, such as would be made with a rat-tail file. This, if gently advanced by the rest, while kept in rapid rotation by the overhead, will not drill a hole, but will form a bead. It must not, however, be traversed along the work, because it would not form a flute. But if now we use the division-plate and index as before, it will be easy to drill a ring of beads round the work, close together, or at any desired distance apart. This is the principle of fluting and beading work, and also of cutting watch and clock wheels, a revolving saw or cutter taking the place of the drill. If this were the sole use of the overhead, it is evident that it would be a very valuable adjunct to the lathe; but there are other uses, to which our attention must be directed. It has been remarked that one great advantage of a self-acting lathe is that it enables a perfectly regular feed to be obtained in making a cut. The tool is advanced evenly and steadily, making a very beautiful finish to the work, if the tool cuts well, and is correctly placed. All that is here needed is a pulley, instead of a winch handle, on the feed-screw of the rest, and that this shall be driven at a suitable rate, by means of a cord from the overhead. The balance-weight of the tension apparatus must be so adjusted as to keep the cord tightly strained, and then there will be no slip, but the action will be as sure as if it was attained by cog wheels or gearing. Now let us go a step further: it was explained in the Chapter on Screw-cutting in the self-acting lathe, that we can obtain any desired pitch of screw by gearing the slide-rest with the mandrel, by means of cog wheels of varying sizes. We can do exactly the same by means of cords and pulleys of proportional size. If we have a pulley on the overhead of exactly the size of any one of those on the mandrel, and connect them by a cord, they will revolve at exactly the same speed; and if we have on the slide-rest screw a pulley equal to the roller in size, the mandrel, and overhead shaft, and slide-rest screw, will revolve exactly together, each turn of the mandrel giving one revolution to the other two, which are thus geared with it. Suppose the screw to have ten threads to one inch of its

length; then, at each turn of the mandrel (and any work attached to it), the tool held in the rest, and actuated by the screw, will advance one-tenth of an inch. If, then, a pointed screw-tool is in the rest, and a cylinder in the chuck, a screw-thread of $\frac{1}{10}$ pitch will be traced upon it, ten turns completing one inch. This will be a screw of ten pitch. Double the size of pulley on the slide-rest, leaving the others as before, and the tool will traverse at half the speed, cutting a twenty-pitch screw. The practical difficulty of this arrangement arises from the nicety required to size the pulleys with accuracy; but it is more theoretical than practical after all, as a little care will overcome it. A greater difficulty arises from the speed with which the mandrel is driven by the fly-wheel. The traverse is proportionally affected, and is correct; but it is too quick for most purposes. The remedy is to have one speed-pulley of the fly-wheel so small that the mandrel shall make but one turn to one of the crank axle, and then to have a large pulley on the overhead, to gear with the smallest on the mandrel. The same thing is done better by having a worm wheel and tangent screw fitted to the rest-screw or mandrel; but this will be more costly, and, unless for exceptional purposes, is not necessary.

We do not, indeed, advocate this plan for screw-cutting in a general way, unless a second shaft can be added, to facilitate the variations of speed. To take down the main shaft, in order to affix a pulley which again needs to be tested several times, and then, after each trial, to replace it, entails a deal of awkward and unsatisfactory work. Hence, in one form of overhead, a short, intermediate shaft has been added, which can be replaced between the lathe centres, in order to turn its pulleys, and again placed in its bearings without having to remove the main shaft at all. The latter is, in fact, too long to be thus mounted between the centres of its own lathe. Sometimes a shaft is added upon two short standards at the back of the lathe, instead of, or in addition to, the high ones which carry the long shaft and its pulleys. In that case, the lower shaft may be quite short, to receive the change wheels, or sized pulleys, which take their place.

From what was said about change wheels in the screw-

cutting lathe, it will be seen that a large variety of threads can be cut with two pulleys only; and here we can do without the intermediate idle wheel, as we can at once change the direction of traverse by merely crossing the driving cord. We can even reckon the sizes of pulleys by the same tables which give us the sizes or number of teeth in the wheels. A wheel of sixty teeth we may match with a pulley of 60in. circumference, or sixty half or quarter inches, and then one of twenty or ten teeth will match a pulley of 20in. or 10in., or half or quarter inches. Thus there will be no guesswork, and the pulley may even be turned accurately to size at once, without repeated testing.

Another use of the overhead is to drive emery wheels or grinders, held in a proper shank, similar to that used for drilling. By this a bar of iron or steel, between centres, can be ground to absolute truth after it has been turned, and even hardened. The lathe centres too, can at any time be ground true, and the points renewed when worn.

From the remarks we have now made, it will be seen that an overhead is such a useful addition to a lathe as to be well worth its original cost. It can, if desired, be also easily rigged up by the amateur with standards of wood, and an axle made of gas pipe, plugged at each end, and with centres drilled and hardened. At the same time, a properly-fitted one, entirely of metal, not only looks neater, but is unquestionably better. The roller should preferably be made hollow, so as to lighten it, and the standards should be substantial enough to check vibration as much as possible.

Before quitting this subject, it may be as well to point out that the drilling spindle, which is supplied with the overhead in the lathes of the Britannia Co., may be fitted to do eccentric work of interlacing circles, by the simple expedient of cranking the drills, so that they shall trace circles as they revolve. According to the length of the cranked part, so will be, of course, the size of circle, each requiring a different drill; but these are so easily made, that the defect in question is unimportant. The proper tool for such work is the eccentric cutter, in which the little tool can be placed at any distance from the centre of

rotation; so that it may be called a cranked drill, with self-contained power of adjustment. With this, or the simpler substitute, the index plate must, of course, be used to determine the distance between the several circles. Their position on the work is regulated by the slide-rest.



CHAPTER XI.

ON CHOOSING A LATHE.

THE selection of a lathe is not a difficult task, if certain things are granted. Let the necessary outlay be of no importance, and let the purchaser know what he wants, and he may obtain his desire without much trouble. But these two requirements are not always, nor generally, forthcoming; and if the first is there, it by no means follows that the second is. A wealthy amateur may, it is true, enter the shop of a first-class lathe maker, and give a general order for an outfit, and on the receipt of the same, together with a bill, in which the sum total is as likely to contain four figures as three, he will not know the use of one-half the things that meet his view. Admire them he certainly will, if his tastes are mechanical; but we do not usually buy lathes as we buy pictures—merely to look at—so that little satisfaction is produced by the purchase. Letting our millionaire alone to order what he pleases, let us address the amateur who can only muster a few pounds, and who, therefore, wishes to get the best he can for his money. If he has never turned at all, but is really a beginner, a very plain and simple lathe will be all that he will need—no slide-rest and no overhead; a 3in. plain lathe, for instance, sold by the Britannia Co. at about £5. This is really a beautiful little tool, running easily, and is capable of a great deal of light work. Draughts, chessmen, egg-cups, ring stands, salt-cellars, bottle cases, boxes of various designs, needle and bodkin cases, tool handles, drawer knobs, rulers—all

kinds of things up to 4in. diameter, and a foot or so in length, can be as well done as upon a larger lathe, costing a score of pounds; or if he is inclined to take up model engineering, he may turn up all parts of small engines in this lathe, as well as any job of light work in brass, iron, or gunmetal. But even in this case we would recommend a lot of practice in turning wood with hand tools before embarking in metal. All metal-workers should be able, for instance, to make their own chucks and wooden patterns, and to turn the handles of their own tools. It is sometimes recommended to learners to buy at once a larger and more expensive kind of lathe, because it will always be capable of additions, and worthy of them. A lathe, *e.g.*, of 5in. centre, with first-class mandrel, and all parts of best make and quality, may, by additions, be gradually converted into an ornamental lathe capable of first-class work in ivory and hard wood. The advice, good as it is under certain circumstances, may be modified somewhat with advantage. Suppose such a lathe to have been purchased at, perhaps, £30 or £35, it has to stand the rough treatment which almost of necessity a beginner will bring to bear upon it. By the time the learner has so far advanced as to begin to aim at higher class work, the bed and other parts will exhibit marks of injury; or it may be—and it is a frequent contingency—the tyro becomes tired of turning, finding it less satisfactory or less pleasurable than he expected, and the occupation gives place to some other hobby. The lathe is then delegated to the lumber-room, or returned to the maker, or sold, at a ridiculous sacrifice, to some knowing purchaser. Hence, it is certainly a more sensible plan to begin with one of the small, cheap lathes, and eventually to replace it entirely by a larger and better, if the art of turning has been found satisfactory. The little lathe will then come in for grinding, sawing, or drilling, if no customer takes a fancy to it; but a £5 lathe is more easily resold at £3, than a £50 one at £30; in point of fact, it will probably not fetch £20.

Let us now suppose that the art has been fairly learnt upon a cheap lathe, and a tolerable amount of skill gained

in the use of hand tools alone. It is now desired to purchase a better lathe, as a permanent machine for the workshop. By this time the turner will have discovered for himself in what direction his tastes lie—whether he is inclined to stick to plain hand turning in wood, or to advance to eccentric and ornamental work in ivory; or whether, on the other hand, he prefers working in metal. He may, of course, intend to work at each of these as occasion offers; but one or the other is pretty sure to have the preference. Ornamental turning, especially in its higher grades, is by far the most costly of all. A little may be done with an inexpensive lathe and tools—but *very* little; and few who get thus far are contented to remain there, but are ambitious to rival the greater works of the masters in this captivating branch of the turner's art. The exact opposite in the matter of expense, is plain hand turning, by which chair and table legs, pillarets for various purposes, Elizabethan twisted work—*et id genus omne*—may be made, and indefinitely multiplied. For this a 5in. centre lathe is very suitable. It should have a bed 5ft. or 6ft. long, either of wood or metal, and should run very easily, and be arranged for high speeds—*i.e.*, the fly-wheel should be large, and the mandrel pulley proportionately small. Mandrel and collars should be of hard steel, kept well oiled.

A wood-turner should be able to stand at his lathe many successive hours without undue fatigue, and he cannot possibly do this if his lathe runs sluggishly. In that case, a few hours at the treadmill would be preferable. Now, this kind of lathe may be purchased complete, and ready for immediate use, and, if properly constructed, will wear for years without deterioration. No slide-rest is necessary, the chucks will be few and inexpensive, and mostly of wood, to be made by the workman himself. Suppose, however, that our friend prefers to take up metal turning, and to make, for sale or for his own amusement, models of engines and machinery which will involve drilling, boring, and occasional screw-cutting. With a plain lathe, without back gear, he can do all this; but he should add a slide-rest. Accurate boring of an engine cylinder can hardly be accomplished

by a hand tool, and, where metal-work is to be freely practised, a slide-rest must be considered indispensable. If nothing else but such small model making is to be done, or the making of scientific instruments, no lathe will beat the little Miniature Screw-cutter, a 3in. centre lathe, fitted complete with self-acting slide-rest and twenty-two change wheels—the cheapest and best lathe ever made of its kind. The price asked (£15 15s.) can hardly pay the makers a fair profit.

If work of a somewhat heavier class is to be attempted, such as a small 1 horse power engine for real use, it will be better to get the next size, viz., a 4in. or 5in. screw-cutting lathe, costing £20 to £25. This is no mere amateur's lathe, but a strong and serviceable workshop tool. The Britannia Co., of Colchester, may be fairly said to have popularised the screw-cutting lathe. Only a few years ago, £50 to £80 was about the lowest price at which it could be obtained; whereas now, the treble-gear'd lathe, which has been described and illustrated on a previous page, can be purchased at that price, inclusive of various chucks and fittings not hitherto included in the estimate. These are, moreover, not shoddy, but sound, substantial tools, which stand the severe tests required by the British Government, for whom they were originally designed.

For short screws, and for all kinds of work in hard wood and ivory, no lathe can equal that with a traversing mandrel and screw guides—generally six in number. Such lathes are not intended for careless use, nor are they fit for metal work of any size, although any light work may be done on them. They are chiefly intended for high-class ornamental work, and have hitherto been sold at prohibitive prices. A newly-designed lathe has now been introduced, which is strong, durable, and cheap, and as a lathe for general amateur work it is exactly what was needed. Fitted with an overhead and a drilling spindle, and eccentric cutter, it will enable a turner to do a great deal of really handsome work; and if an eccentric chuck is added, the outfit will be complete for anyone who cannot afford to give fabulous prices for complicated apparatus.

CHAPTER XII.

GRINDING AND SETTING TOOLS.

IN no mechanical trade can good work be done by badly sharpened tools. Keeness of edge is necessary, and also something more, namely, a *correct form* of edge. To the turner this is essential; yet it is the very detail of practical work which an amateur often neglects. Tool-grinding, being anything but a pleasant job, is put off as long as possible, and then it is done hurriedly and inefficiently. A grindstone worked by a treadle should find a place in every workshop. Such a machine is now readily obtainable, with an iron water-trough below, hinged so that it can be lowered when done with, thus preventing the stone from resting in the water, and becoming soft in one place—a defect that will rapidly throw it out of truth. Even when grinding, the water need not flood the stone. Let it be wet enough to prevent particles of steel from becoming bedded in it, as well as to prevent heating in the tool; but a stone running over with water is a nuisance, and makes such a mess as ought not to be tolerated, even if the water does not run down the arm, and sodden the shirt sleeves, which is a very good lesson of “How *not* to do it.”

The faces applied to the stone in the case of a turner's chisel, which is ground on both sides to equal bevels, are to be made as flat as it is possible to make them; and the bevels must be also long, so as to produce a very small angle at the cutting edge. A short bevel is of no use for soft-wood turning. The general fault is a rounded or convex face, made still more so by the final touches on the oilstone, by

which a finish is given. If the bevel is not flat or slightly hollow, no satisfactory work can be done. A turner's chisel is not ground off square to its length, but slanting, so as to form one obtuse and one acute point; therefore, during the process of grinding, the tool must not lie quite in the run of the stone, but a little on one side, causing the blade to lie at a small angle across it. In grinding and setting a plane iron, the face is ground to an acute angle, and then this angle is reduced some two or three degrees by the oilstone, which makes a second narrow facet. But with a turning chisel, the oilstone should merely remove the slight burr or wire edge caused by the stone, without reducing the angle perceptibly. This will give the utmost possible keenness to the tool. There are one or two appliances for assisting an amateur in this operation, by supplying a guide to insure the flatness of face; but it is better to do it by hand alone, and not to become dependent on artificial aids.

The gouge requires similar treatment to a chisel, but is more difficult to sharpen nicely. Of course, the part to be ground is semi-cylindrical, and, to prevent cutting a groove in the stone, the tool should lie across it, and be rolled to and fro upon it; but in the other direction there must be no rounding. The bevel, as such, must be flat, so that a straight-edge, applied to it lengthwise, will touch it equally from the end to the point. In this case the inside, or hollow part, is not bevelled, but is kept quite flat, and, to take off any wire edge, an oilstone slip is used, called a gouge slip. It is wedge-shaped, with one thick and one thin edge, and both are rounded, so as to be suited to gouges of different sizes. Two such slips will suffice. We may sum up the previous remarks by saying that the rule for grinding chisels and gouges for soft-wood turning is to form flat, long bevels, merely using the oilstone to remove wire edge, and bring the process to a perfect finish, without reducing the angle to which the tool has been ground to any perceptible degree. This, like other mechanical operations, always presents a certain amount of difficulty, which practice will overcome. The secret of success is patience; to hurry the job is to spoil it.

This perfect flatness of the face of a tool holds good on such as are to be used upon hard wood and metal; but in these the actual edge is not so keen, but contains a larger angle. Most of these tools are ground on one side only, those which are hollow, like beading tools, being laid quite flat on the stone, and the hollow part only receiving a rub from a gouge slip. When they absolutely require grinding, owing to breakage, they are ground upon cones of brass fed with emery. This, however, is only likely to be required in the case of tools for ornamental turning. Hand beading tools are merely rubbed quite flat upon the oilstone. It will be almost self-evident that accurate grinding needs an accurately level stone, the face of which must be neither hollow, nor rounding, nor convex. A convex face will, of course, produce a concave edge, and *vice versâ*. Hence, a careful workman takes as much care of his grindstone as of any other tool, and, as soon as ever he finds it the least out of truth, he sets to work to true it up again. This is best done by turning its face with a tool formed of a bit of nail rod, which is rolled over as one part gets blunt. It is rested on the frame, or on a block of wood laid across the bearers. The stone is kept damp, and the turning continued, until a perfectly true face is obtained. It is then finished with a bit of hoop iron. The job is a tiresome one, and dirty, but more so the longer it is delayed.

Among other tools which will need occasional grinding are screw or chasing tools. Now these are formed upon hobs, or revolving screw-taps, which cut the teeth. They are, consequently, never ground except upon the upper side, or flat face, which will perfectly renew their cutting edges. Sometimes this face is slightly bevelled off at the end where the teeth are; but this is a lazy plan, not to be recommended. They seldom need either grindstone or oilstone, but when necessary let the upper face be kept quite flat. The tools will, of course, get thinner, but are equally serviceable; and if they become too weak for metal, they will do perfectly well for hard wood, and even better for bone and ivory.

The graver, the tool *par excellence* for iron and steel, is a square bar of steel ground off at an angle of 45° from

corner to corner. In this case, again, a perfectly flat face is alone capable of producing accurate cutting edges of 60° . If the face is rounded, all is uncertainty, for the cutting edges are then of no determinate angle, nor are they capable of being placed accurately in the best position for cutting. There are small grindstones and emery wheels, fitting on a spindle, to run between the lathe centres. These are of necessarily small diameter, so that, if a tool is held still as they revolve, a flat cannot be ground, but a concave surface. Now, of the two evils—a rounded or a hollowed face—the latter is unquestionably the least, as it does not prohibit the production of a sharp edge. But it is an evil nevertheless. By drawing the tool to and fro lengthwise upon the stone, the error may be partially annulled; but, on the whole, these small grinders are more suited for drills and punches, and small tools, than for chisels and such like. Moreover, no one who values a good lathe will use such apparatus, especially emery wheels. The grit gets into the collar, and grinds the bearings, especially if the collars, or bushes, are of brass or gunmetal. The particles become embedded in the softer metal, and will cut a nick in the mandrel in a very short time. It is far better, and but little more expensive, to have all grinding apparatus on a separate stand. Of oilstones there are several kinds. The Arkansas is good, and for rough work, the Tam o'Shanter. But a real good Turkey beats all the rest. A bit of even grit, without hard spots, is a treasure worthy of all care. Perhaps, next to this, carpenters appreciate a "Charley Forrester," the real name being, not Charley, but Chorley, in Cheshire, whence the supply is obtained. This stone will produce a very fine edge.



CHAPTER XIII.

ON METAL-SPINNING.

THE art of metal-spinning is the most interesting subject that an amateur or novice can practise, and on which very little has, up to the present, been written to guide, or, at least, to be of any practical value; therefore I will describe the process, &c., in as few words as possible, and without going into technical details.

Assuming that the amateur possesses a lathe on which a high speed can be obtained (as the success of the operation depends a great deal upon this); also taking it for granted that he understands the working of his lathe, and is able to use his tools, at least for wood turning—all the addition he will require is a tool-rest with at least six $\frac{1}{4}$ in. round holes drilled in about $\frac{1}{2}$ in. apart, in which small iron or steel pegs are placed to serve as a side rest for obtaining a powerful side leverage to his tool (see Figs. 2 and 3, Plate XV.). These have to be shifted as the work advances or is spun over the wooden pattern.

The tools required are a roughening and a finishing tool, sometimes called burnishers; also a beading tool (see *aa*, *bb*, and *c*, Plate XIV.). Having all these, I will now proceed to describe the process :

After having chucked, or screwed a piece of hard wood on your lathe mandrel, turn it to the shape or pattern desired, care being taken at first not to attempt an elaborate pattern, but a plain one, that is not too deep; after this, cut out a circular disc of sheet copper, or brass, which,

of course, requires to be previously well annealed by placing it into a bright fire, and making it just red, and then cooling—which latter is best done by plunging it into cold water, and wiping dry with a bit of waste, which gets rid of a large portion of the oxide—and it is ready for use. Place this next your pattern, backed by a piece of turned wood to keep the metal in place and from shifting; then bring up your tail-stock (see Figs. 2 and 3, Plate XV.: B, turned wooden pattern; C, circular metal disc; D, piece of turned wood or backing; and E, tail-stock). Next lubricate the front face of the metal disc on which you are going to operate with a little machine oil, applied with a brush or piece of oily waste, to prevent the tool scratching, and save unnecessary friction, adjust your rest (A, Figs. 2 and 3, Plate XV.) at a suitable distance, place in your pins or pegs, and you are now ready to commence operations.

Place your tool (*aa*, Plate XIV.) in the position as shown in Fig. 3, Plate XV., and bring a side pressure to bear on your metal disc, and, with a sweeping motion from the centre to the outer edge of disc, try to force the metal over your pattern, taking care that the outer edge and sides of disc always run perfectly true, as the success of forcing the metal over greatly depends on this. Should you by accident slip over the outer edge with your tool, which would cause your metal to buckle, remove it, and straighten; and do not have your disc larger than is actually required—if too large, turn down with a graver. Having got the metal satisfactorily forced or spun over the wooden pattern, finish with tool *bb*, Plate XIV., by using the flat edge against your metal, which, if properly done, ought to give it the appearance of a highly burnished surface, without showing any of the ridges previously made by tool *aa* (Plate XIV.).

Figs. 5 and 6 (Plate XVI.) are examples of two different patterns which will best show the gradual shapes the metal ought to assume, commencing at 1, and finishing at 5. The novice, in his first attempts, will have to give the metal as it progresses several annealings before he will get it spun over, but after practice will do so without any difficulty.

The gauge or thickness of metal to be used at first should

FIG. 1

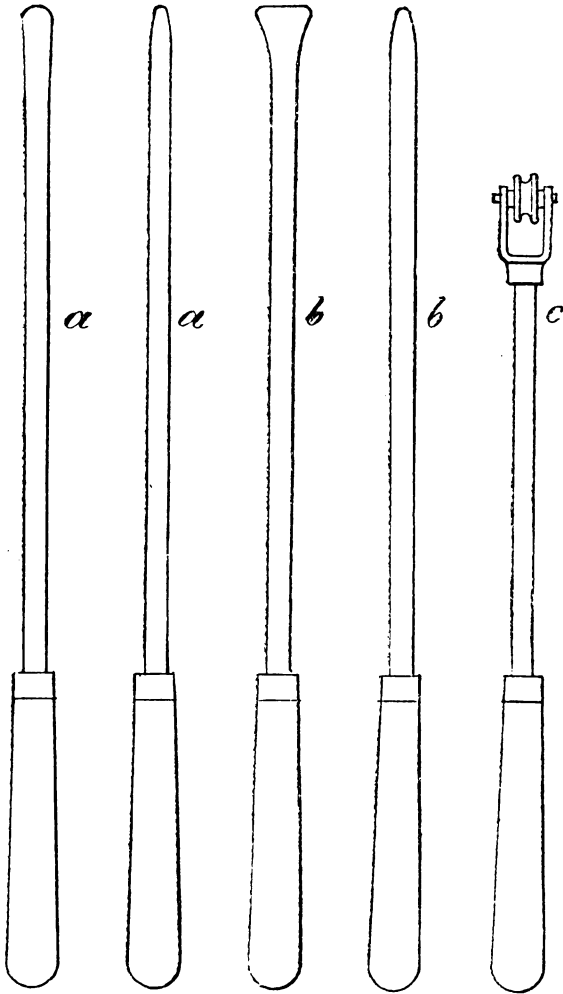

PLATE XIV.—TOOLS FOR METAL-SPINNING.

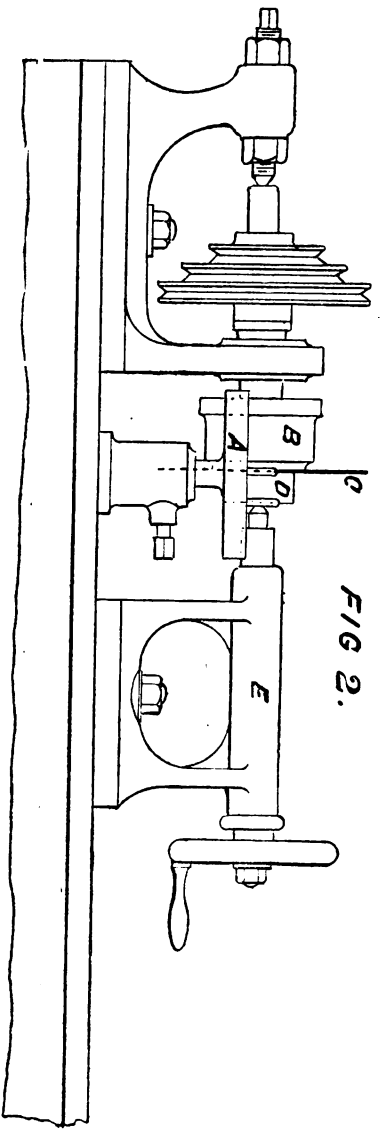

FIG. 2.

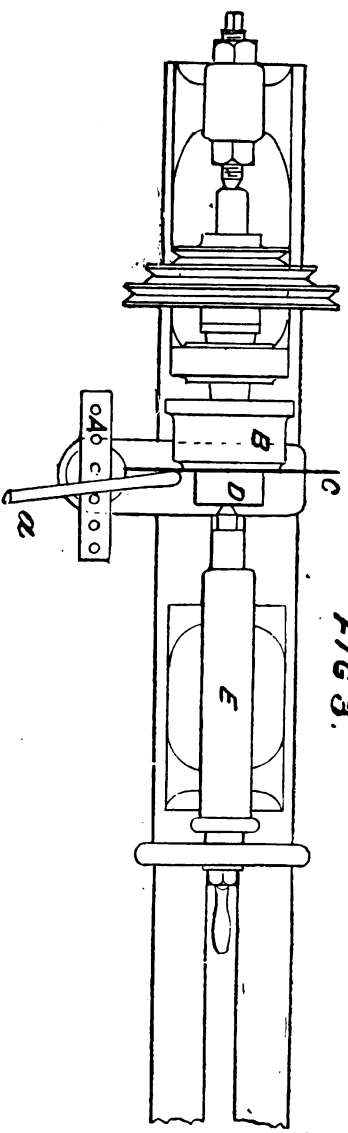
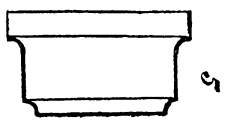
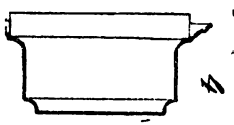
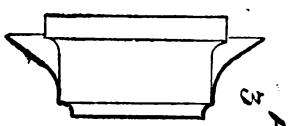
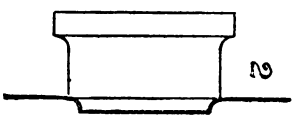
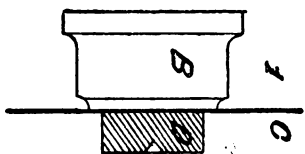

FIG. 3.

PLATE XV.—LATHES FOR METAL-SPINNING.



1

2

3

4

5

FIG. 5.

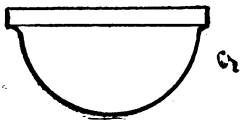
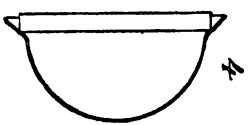
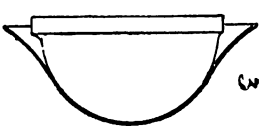
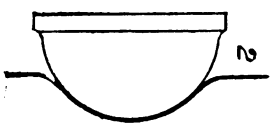
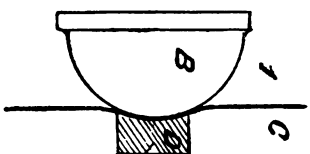

1

2

3

4

5

FIG. 6.

PLATE XVI.—SIMPLE SHAPES FOR METAL-SPINNING.

be 26 B.W.G.; but after the novice has become proficient, thicker metal may be used, and other metals may be substituted, such as zinc, tinplate, nickel silver, &c.

The variety of work that may be done is very great; elaborate patterns may be spun and joined together by beading or soldering, &c., to suit the taste and requirements of the amateur. The examples given here are only to illustrate the process.

After practice, the worker will see numerous objects which he can spin; and as he can make his own patterns, the cost of experiments are trifling—the metals being thin, cost but little, and if spoiled can be sold for old metal.



CHAPTER XIV.

THE ORNAMENTAL DRILL AND ECCENTRIC CUTTER.

ALTHOUGH we have already disclaimed all intention of treating fully on ornamental turning, which would need many costly illustrations, and a vast extension of the size of this book, the two instruments heading the present chapter seem to call for attention. The first is, indeed, supplied very frequently with the overhead, and the latter enables certain work to be done which is not strictly of the ornamental class.

THE DRILLING INSTRUMENT,

Of which an illustration is appended (Fig. 25), consists of a square stem of steel, usually finished to the size of $\frac{1}{8}$ in., which enables it to enter and fit accurately the receptacle of an ornamental turning slide-rest. It lies in the channel of this



FIG. 25.—THE DRILLING INSTRUMENT.

receptacle, and can be faced about in either direction, so as to stand parallel with the mandrel, at right angles to it, or at any other intermediate angle. The top or side of a box, or other article, may therefore be operated on with equal facility. At each end of the square bar or stem a steel collar

is inserted, which is hardened to reduce friction and prevent wear. The front collar, next the drill, is coned out accurately. The spindle, with a socket at one end for the drills, and a steel pulley at the other, is also of steel, and is hardened where it passes through the collars. The utmost care is needed in fitting it; and when it begins to run loose, it is tightened in its bearings by giving a turn to the nut behind the pulley.

So great is the accuracy required in this instrument, that the drills have to be turned in the spindle itself after fitting

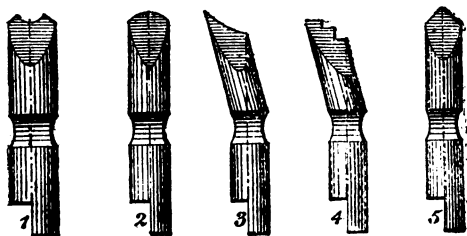

FIG. 26.—ORNAMENTAL DRILLS.

their shanks into it. In no other way can the cutting ends of the drills be made sufficiently true. Take, for instance, the drill used for beading, on which a few words have been written in a previous chapter. It is seen, by the annexed drawing (No. 1, Fig. 26), to consist of two cutting points, united by a semicircular hollow. If it runs accurately true, the result will be a hemispherical knob, or bead, perfect in form, and free from any fash or roughness on either side at its base. If, however, the points are not equally distant from the axial line, one will cut into the work of the other; and if the curved part, which is also keenly sharpened, is irregular in shape, the same result will occur, and no good work can be done. Or if, again, a pointed drill is used, and the point is a hair's breadth out of centre, it will describe a minute circle, and mar the work. Hence, also, the curved edges of these little tools cannot be finished with a file alone, but are ground upon little conical grinders of brass, fed with fine emery, which gives them

the necessary accuracy, as well as a keen and polished edge. The drills with flat or stepped edges are finished with little square slips of oilstone.

Evidently, tools needing all this care in construction cannot be very cheaply made, and, being costly, many amateurs learn to make their own. It is not a very difficult task, but it is decidedly a tedious one, and the better way is to be contented with a small set, and to take care of them. A good deal of very pretty work may be done with a dozen, carefully selected, and kept in good working order.

The way to make them is to take a small bar of steel, as near the size of the socket as possible, and to fit it very carefully with a file, so that it shall enter truly, and fit without shake. Even this requires care, and turning is better than filing; but, at any rate, the bar should be centred in the lathe, and filed while in rotation. The socket is usually made with a taper hole, or with a cylindrical one having a cross-mortice, in which case the drill shank has a flat on one side. This secures its position, and affords a ready means of pushing it out by the insertion of a small lever. That illustrated (Fig. 25) has a side screw, to secure the drills, and the screw will mark the tool, so that it can always be put into its socket in the same position. In fitting such a socket, the bit of steel must be secured by the screw before turning it of the required form, otherwise, the next time it is inserted the screw will force it out of truth. Supposing the bit of steel fitted and cut off, so as to stand out about half an inch, the shank is secured in the slide-rest, and a cord arranged to drive it from the overhead. A hand-rest is now brought up, and the drill is turned up by means of a graver and small files. If it is for beading, the end is turned cylindrical for a distance of about $\frac{1}{2}$ in., or rather less, which, when the sides are subsequently flattened, and the end forked by a rat-tail file, will insure the points being equidistant from the axial line of the spindle. The curve filed out, will, as stated, have to be finished to accuracy on a conical grinder. If, instead of a beading, a fluting drill is needed, the end will be turned to a hemispherical form, and the sides will be afterwards filed flat. There is an apparatus often sold to assist in grinding the

curve of a fluting drill; but it is sometimes done by the eye. It will, nevertheless, make a great difference in the appearance of the work to have a perfectly-formed curve at the cutting end of the drill.

These precautions may be considered, by some of our readers, unnecessary; but if they could compare good ornamental work with that which is, at least, of indifferent quality, they would at once recognise the great difference between the two. In the one, the tool leaves not only a clean, decided cut, of well-defined outline, but a polished surface, which is due to the sharp, accurate, and burnished edge of the tool; in the other will be irregularity and indecision of outline, and a rough surface, which cannot afterwards be smoothed and polished. This polish produced by the tool is an essential of ornamental turning. No sand-papering or varnishing is permissible, as it rounds off edges, and gives a poor look to the work; all that is ever done is to give a rub with a hard, dry brush; and even this is often impossible with delicate tracery, for drilling can be so finely executed as to produce something comparable to lacework.

The actual work of drilling is carried out as follows: We will suppose it desired to arrange a row of beads round a box cover, and on the face of the same: the manipulation will, however, be the same if the beads are to be on its convex surface. Having selected a drill of suitable diameter, and inserted it firmly in the socket of the drilling spindle, the rest is turned, so as to place the instrument parallel with the lathe bed, and with the centre line of the drill spindle exactly true with the lathe centres. This position is essential. We will suppose that the division-plate has 180 holes, and that the index point is in Zero. As the work is, presumably, smaller considerably than the face of the mandrel pulley, there will not be room for 180 beads, but the index will have to be shifted a certain number of holes after each advance of the drill. A large pulley has 360 holes in the outer circle; but, very possibly, there may only be 180 for the outside circle, with, perhaps, other smaller circles of 100, 112, 96, or other generally useful numbers, those divisible into as many equal parts as possible being selected. Now, 180

will divide by 2, 3, 4, 5, 6, and is a very good number to have on the pulley; we can therefore drill 90, 60, 45, 36, or 30 beads, and have only to decide whether they shall touch each other, or nearly so, or whether there shall remain a decided space between. Suppose we start on a trial of 60: there will be three holes to move the index each time. Bringing up the drill very gently, a slight circle is traced—just barely visible. The index is then shifted three divisions, after withdrawing the tool, and a second very light cut is made. If these actually touch, they are too close for a beading drill of that size; but a smaller one can be used, or the index must be shifted one hole—*i.e.*, there will now be four holes to move it each time, and instead of 60 beads we shall get but 45. These trials must always be made with care, or, when the cut is deepened, one bead will be found to be cut into and spoilt in cutting the adjacent one. If it is found correct, all that remains is to advance the tool each time to precisely the same distance, and to shift the index correctly after each cut. This entails careful counting, and, in practice, becomes very tedious; but there is no help for it, except by means of a very expensive automatic counter. We may now suppose the circle of beads correctly drilled, and that, as an additional ornamentation, radial flutes are required. Fluting the outside of a cylinder has already been described, and, of course, for the present operation on the face of the work, similar round-ended drills are needed, which must, therefore, be substituted for the beading drill. In all work intended for face ornamentation, a minute centre point should be left when it is turned, to form a guide for exact centrality of the drill, or for the tools used in the eccentric cutter. If such is not the case, let the index be removed, so as to free the pulley, and let such a mark be now made. Then bring up the fluting drill, and set it spinning, and note if it is exact to height of centre; if not, let it be accurately adjusted. It is assumed that, for such work as this, an ornamental slide-rest is at hand; but it is a costly affair, and it is just possible to use that intended for metal, only the screws are less accurate, and there are no adjusting stops to check the advance of the tool, so as to insure all cuts being of equal depth, and all flutes of equal

length. Some mark must therefore be made, or some stop apparatus contrived instead. In any case, such work can only be done *tolerably* with a rest of this kind; but care and patience will accomplish wonders, and, with even worse appliances, marvellously good results have been attained.

But to resume. The drill being carefully set to height of centres, and its pulley, of course, banded to the overhead, the tool is traversed bodily by the slide-rest to form the flutes, while the index point determines, as before, the distances between them. Trial is also made of such distances—as was done in the case of the beads—so as to determine how close together they shall be, and whether or not each shall touch its neighbour. The length of each must be determined; and, unless a proper rest is used, which has divisions marked, and also a pair of proper fluting stops, a little mark is to be made, with a fine centre punch, at which, at each traverse, the slide of the rest is to stop. Now, with radial flutes on a flat surface, such as the top of a box-cover, it will not look well to have them equally broad and deep at both ends; yet the same drill must cut them. How is it to be managed? Simply by placing the rest at a slight angle, by means of the quadrant-plate, instead of having it truly parallel to the face of the work. Thus, the drill must be quite out of cut when it arrives at the centre, and at its fullest depth at the other end of its course. There is an advantage, moreover, in this plan, because it is not necessary to have any mark or stop at the shallow end of the flute. The tool will cut itself clear with accuracy, each time, just before it reaches the centre, or, if preferred, at a point more or less distant from the centre, according to the setting of the rest. Radial fluting always has a nice effect, and is a simple and easy process. A very effective kind of fluting is the stepped fluting, cut with different-sized drills. A broad flute is first cut, as already described, of equal depth from end to end. A narrower drill is then substituted, and carried along so as to cut away the bottom of that first made, and this is carried to a given depth. With a still smaller drill, the second flute has its centre cut away and deepened. Beads of this kind are also done at one cut by a stepped drill, which leaves its counterpart upon the

work. It is also cut with drills having a square end, like a chisel, which gives a different effect to that produced by a round-end tool; but the mode of work is the same in all cases.

THE ECCENTRIC CUTTER.

This instrument—of which an illustration is annexed (Fig. 27)—enables a turner to do much of the preceding work; but, in addition, he has the means of carving out many forms otherwise incapable of being made in the lathe—such, for instance, as cubes and polygons. The eccentric cutter will also produce most beautiful and intricate patterns on face work, when such

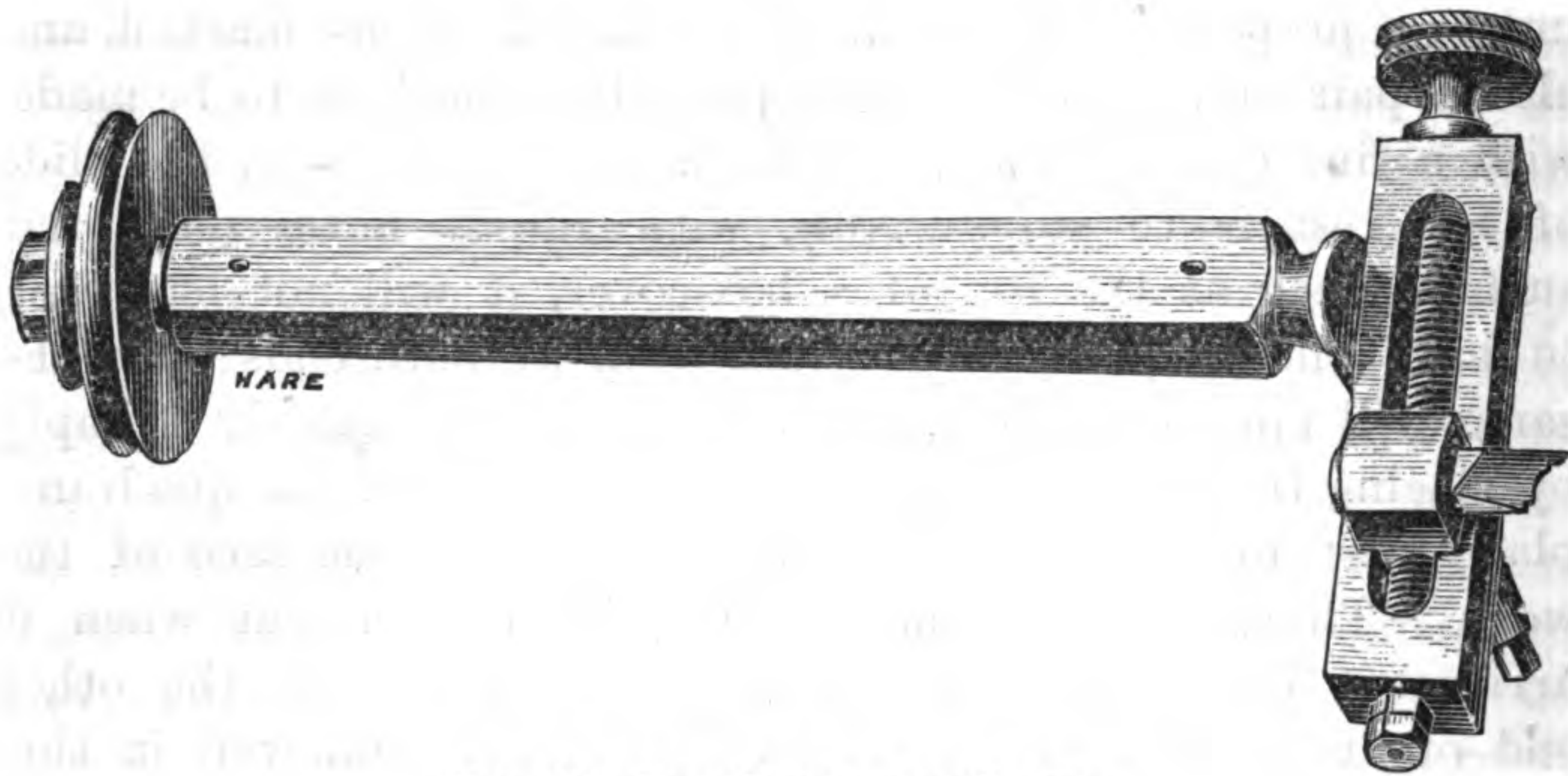

FIG. 27.—THE ECCENTRIC CUTTER.

can be composed of interlacing circles, as is the case with the majority of such patterns. For stepped fluting it is also a superior instrument to the drilling spindle, because its range is greater. By its means, broad recesses can be cut out; and, the more it is used, the more will its many uses be discovered. The simpler operations carried out by its aid we shall proceed to describe; the rest will soon be discovered by the turner.

The eccentric cutter is made, up to a certain point, exactly like a drilling instrument, but, instead of a socket, a small steel frame is attached, of which, when the apparatus is lying in the tool receptacle of the rest, the upper face is exactly level with the lathe centres. It will be seen by the drawing

that it is filed down for that purpose. The frame constitutes a little slide-rest, to hold the small cutters, which are carried along by a leading screw of ten threads to the inch, and are secured, by a screw clamp, at any distance from the centre. The screw head is graduated to ten divisions, so that each shall represent upon the slide $\frac{1}{10}$ in. Generally there are also engraved half-divisions. To set the instrument for face work, a point tool is inserted, and made to tally with the minute mark left in the centre of the work, as described in reference to the drill. If all is "at centre," and the instrument made properly, the tool will drill a hole, and not cut a circle. Unless it will do this, it will be useless for ornamental turning; and when the tool is thus set, the index at the milled head of the slide ought to read Zero. If it does not, however, it is not fatal to the tool, but is inconvenient, especially in copying any published patterns. It must be always remembered that, as the *face* of the slide is diametrical, the face of the tool, and not the bevelled side, must lie upon it; and in testing it, that side must be really dead flat, and not in the least bevelled off at the point, otherwise the instrument may be condemned unjustly. Evidently, to a certain extent—i.e., if the frame is not in the way—the eccentric cutter can be used, with suitable tools, for the work more generally effected by the drilling instrument, only the shanks of the tools must be flat.

But the range of work that this instrument is capable of is far wider than that of the drill. With a quarter-hollow flat tool, very large beads can be cut, and with a pointed tool an immense variety of patterns can be traced and deeply cut. All such patterns are produced by interlacing circles of various sizes. These can be placed diametrically, like A, Fig. 28, or carried round the circle like B. In the former case, the work would be held still by the index peg; in the latter, the mandrel would be moved round so many divisions after each cut. With a metal turning rest it would be very difficult to space the radial circles, especially if they are to be cut at very small distances apart. The spacing must necessarily be done by the cross slide, moved a certain distance after each cut by the screw; and unless it is

an unusually accurate one, and its head divided, the result would show great unevenness and inequality. Here, again, as in all such work, the very slightest irregularity in a pattern is fatal. Hence, with such a rest, it will be easier to make circular work, because the circles will be spaced by the division plate and index. Even then, however, each advance of the tool must be to an equal degree, or some circles will be cut more deeply than others, which will in effect alter the distances between them. Fig. 23, of course, merely shows the nature of this work. In practice, there would be five

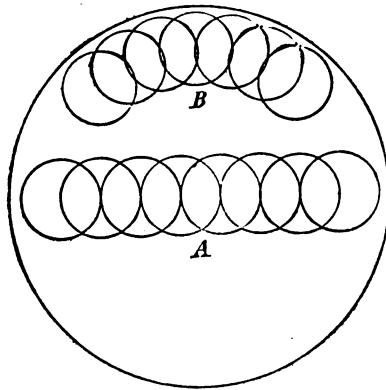

FIG. 23.—INTERLACING CIRCLES.

or six circles where one is drawn here. Coarse work, however, *deeply cut*, looks well in ivory.

Passing from traced, or mechanically engraved patterns—a variety of which will suggest themselves in practice—we must go on to show how this instrument is used as a carving tool, and especially to cut out rectangular work. Figure 29 represents a cylinder which has been turned, and is held in the chuck (A), and by the back centre, if necessary. The part B is flat, and to cut it so the eccentric cutter is used, with a small, flat, or round-ended cutter in it. The slide-rest is adjusted so as to place the stem of the instrument exactly at right angles to the lathe bed and mandrel. The ornamental rest has a cradle, to ensure this position, but

it is quite possible to do without it. If the cylinder is itself true, it can be secured, as usual, by the index peg, and then, when the rest is set true—as nearly as can be done by hand—the tool may be set just to touch one end, and can be carried along the work horizontally, at height of centres. If it just touches throughout its traverse, the setting is true; if not, the rest must be re-adjusted. If now the tool is set just to cut the cylinder, and rapidly rotated by the overhead while carried along by the slide-rest, a series of circular cuts

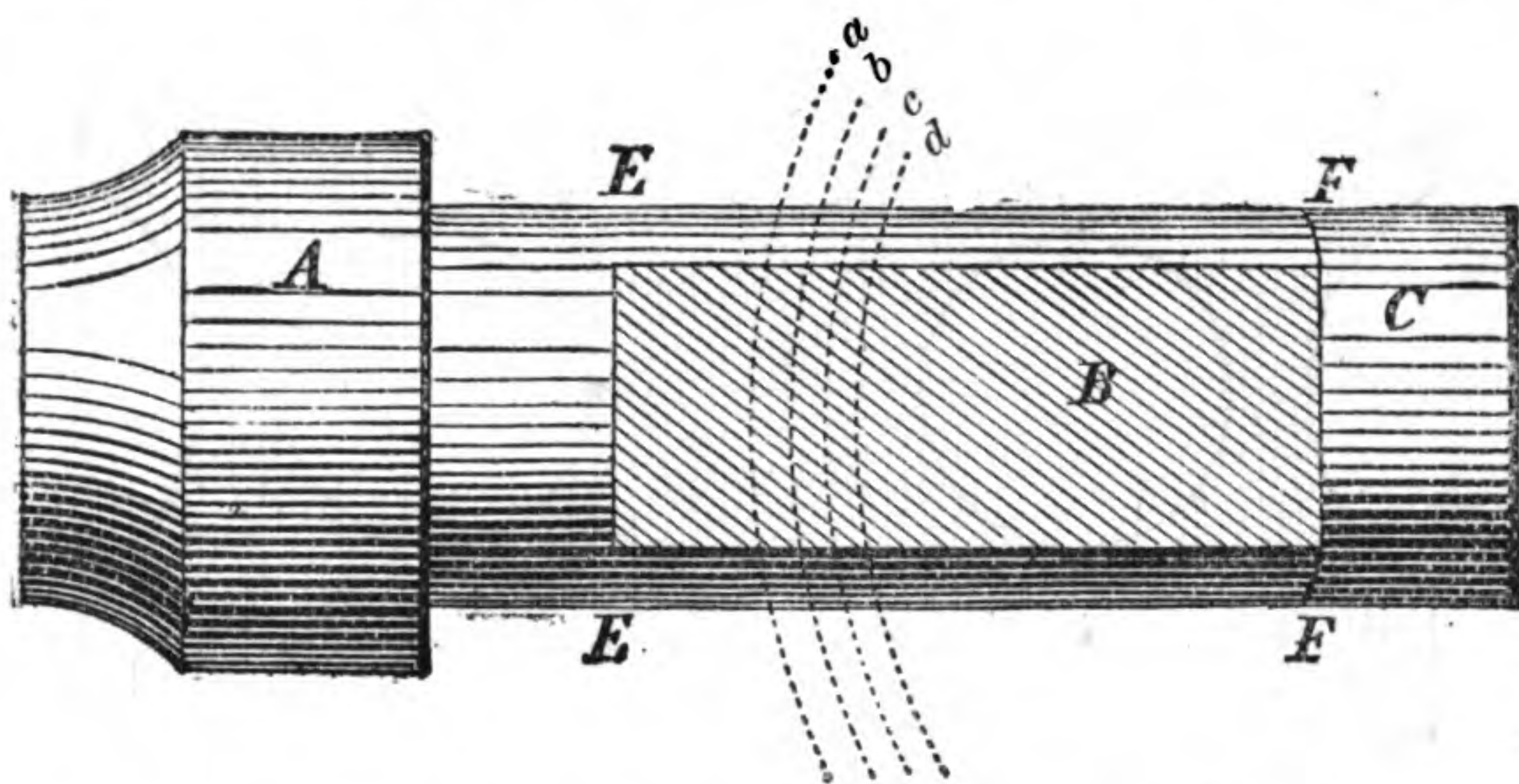

FIG. 29.—SQUARING CYLINDER BY ECCENTRIC CUTTER.

(*a*, *b*, *c*, *d*) will result, running into each other, and a flat will be produced upon the cylinder. It is represented as bounded at *E F* by straight lines; but these will, in reality, be curved if the flat is not cut clean out at each end of the cylinder. If it is so cut, the curve will be obliterated. If the index peg is, to begin with, in hole 180, it is plain that, by moving it to hole 45 ($\frac{180}{4} = 45$), we shall turn the cylinder exactly one quarter round. If, therefore, we cut one face by guess, until nearly the right size, and then, shifting to 45, we do the same, the cuts will at last meet, and produce an angle of 90° , or a square. It will be exactly right if the tool at 45 *A* has been advanced exactly as far as it was at 180. When the two cuts thus meet, therefore, the distance the tool has advanced is noted, and marked upon the rest-slide. In cutting the other two flats, it will only be necessary to work exactly to the mark thus made. Here, again, an ornamental rest has a stop-screw, as well as marked divisions. At present,

an ornamental rest cannot be got under £10, and may reach £75 with all recent additions. But the Britannia Company, Colchester, are scarcely likely to allow this state of things to continue. Undoubtedly, a very useful rest may be produced for less money, although the finish may not equal that of the

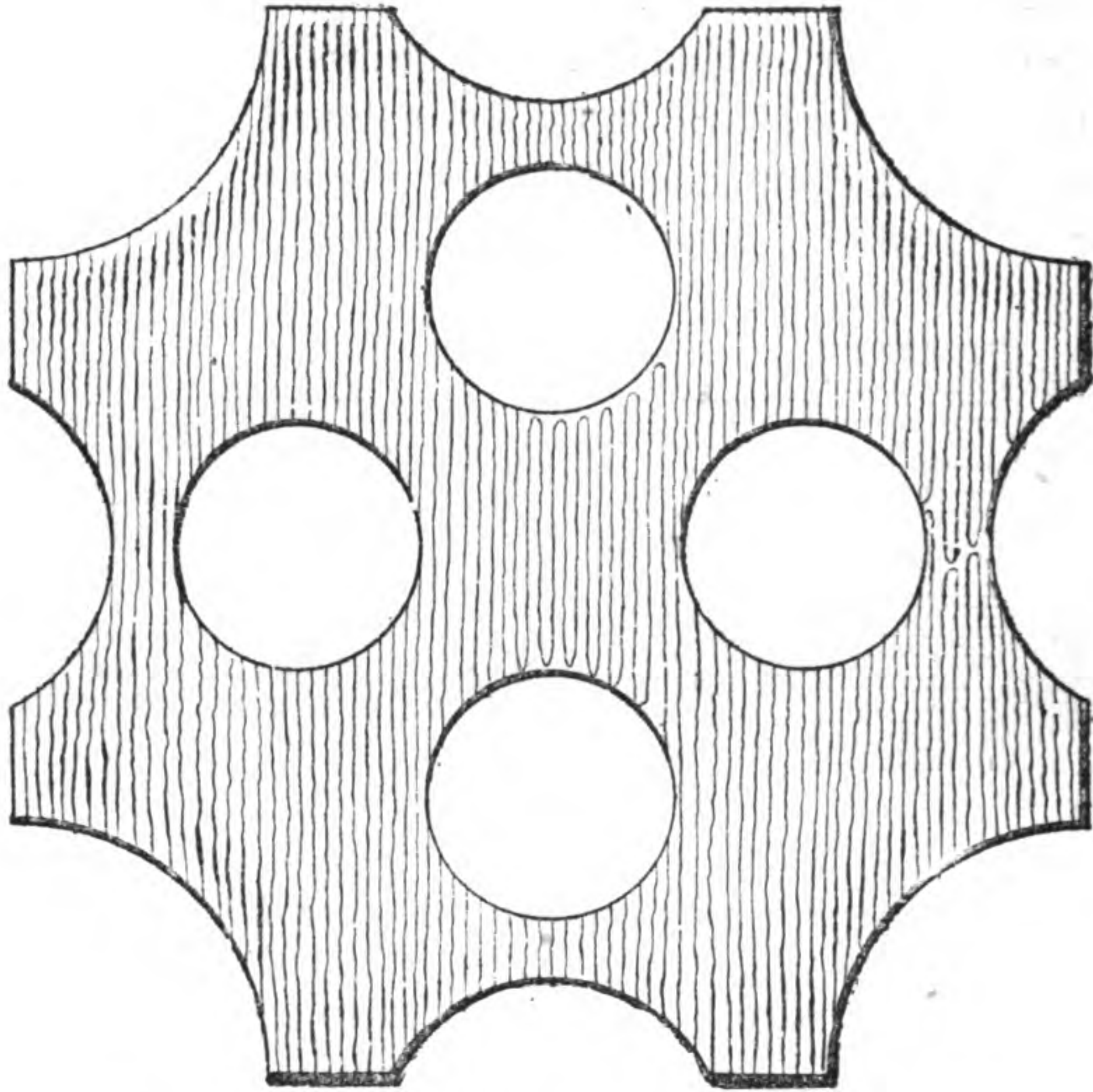

FIG. 30.—SHAPING WORK WITH ECCENTRIC CUTTER.

more costly article. Ornamental turning would, probably, in that case be more extensively practised; and it has a fascination which few can resist who have once given it a trial, or seen it done by a skilled hand. From the very slight sketch given here, it will be readily conjectured that the eccentric cutter is of very extensive service as a carving, beading, fluting, and engraving tool. It can be used to cut out rings and washers from flat pieces of ivory, and small or large discs, such as are used for counters. Such a plate as represented in Fig. 30, which might be the base of a vase, or anything or nothing, can be cut out by this instrument with great facility, even if $\frac{1}{4}$ in. thick. The tool has to be set in very rapid revolution, and advanced very gently;

but the work proceeds with fair celerity, and the cut is clean, without leaving tool marks, if the cutter is itself well made and strong, and its spindle works, without the slightest shake, in its bearings. With proper adjustments, cubes, and geometrical solids of various kinds can be accurately carved, and the several surfaces left from the tool highly finished, and even polished.

•



CHAPTER XV.

THE GREATOREX PATENT MILLING MACHINE.

F^{IX} the apparatus on the lathe bed at a convenient distance from the headstock of the lathe, the cutter being already in its place; there must, of course, be a suitable chuck to hold the work. It is convenient to screw out the reducing socket the same size as the bore chuck of the lathe, and so utilise the lathe chucks when desirable. For larger work, it is best to make the chuck to fit the revolving socket (A, Plate XVIII.). Now for simplicity we will suppose we have a hexagon nut to shape up: A tool (Fig. 1, Plate XVII.) is fixed in the drill chuck of the lathe, and the object to be milled screwed to a peg chuck fitting the reducing socket, or the revolving socket (A, Plate XVIII.), as the case may be, the reducing socket or chuck being fastened by the screw-bolt (B); it is then adjusted, by the wheel (C) of the vertical slide, to its requisite height; *i.e.*, the centre of the thickness of the object to be milled should be about the height of the centre of the tool. Bring up the running nut (D) to support the table (E), and fasten the set-screw (F). Next see that the spindle of the spring catch (G) engages with the requisite series of division holes. In this case it will be the series of twenty-four holes, and taking every fourth hole gives the six sides required. The cut should be now set by the wheel (H) of the horizontal slide, and the socket (A) secured by the set-screw (I). Now traverse the work by the handle (K), but be sure not to let the work come on to the cutter until the lathe is working at a fair rate. Set the

Fig: 1

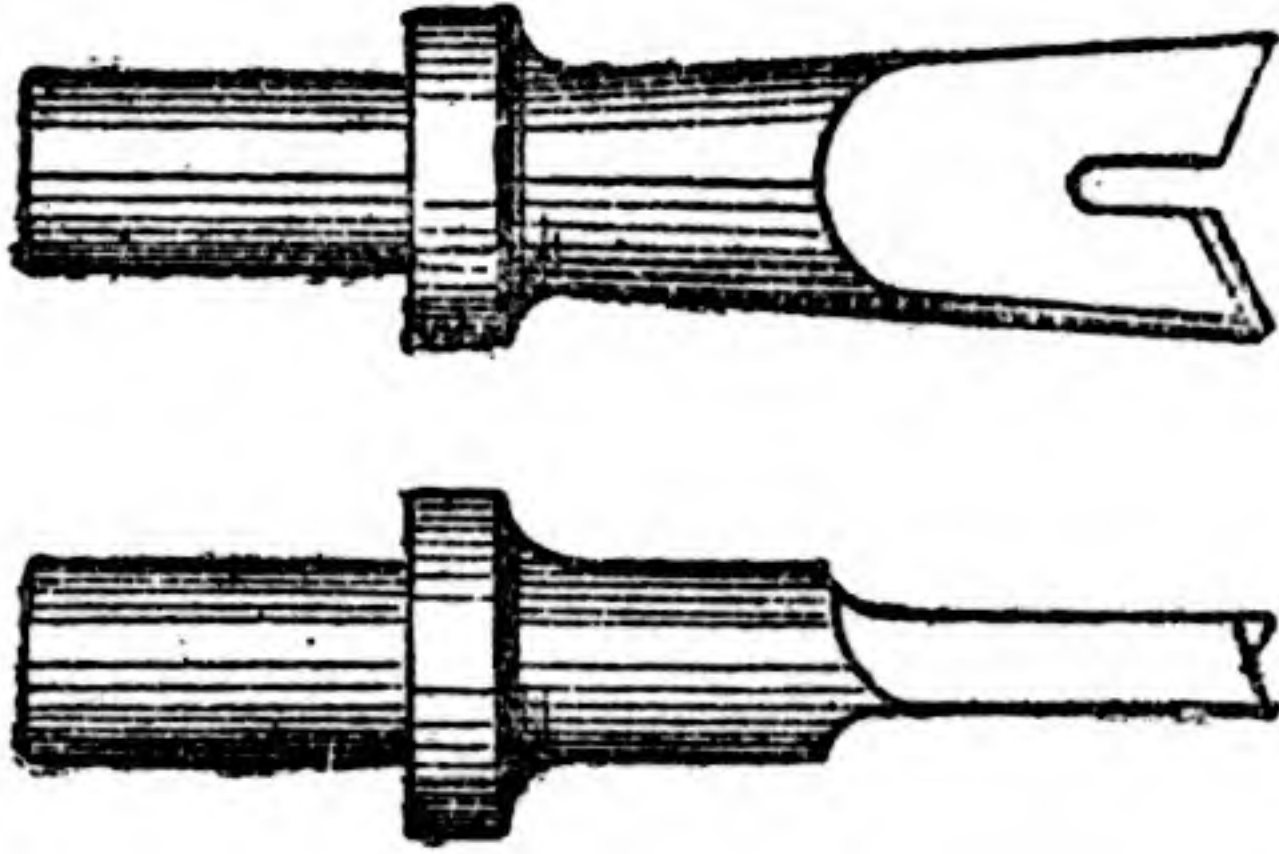

Fig: 2.

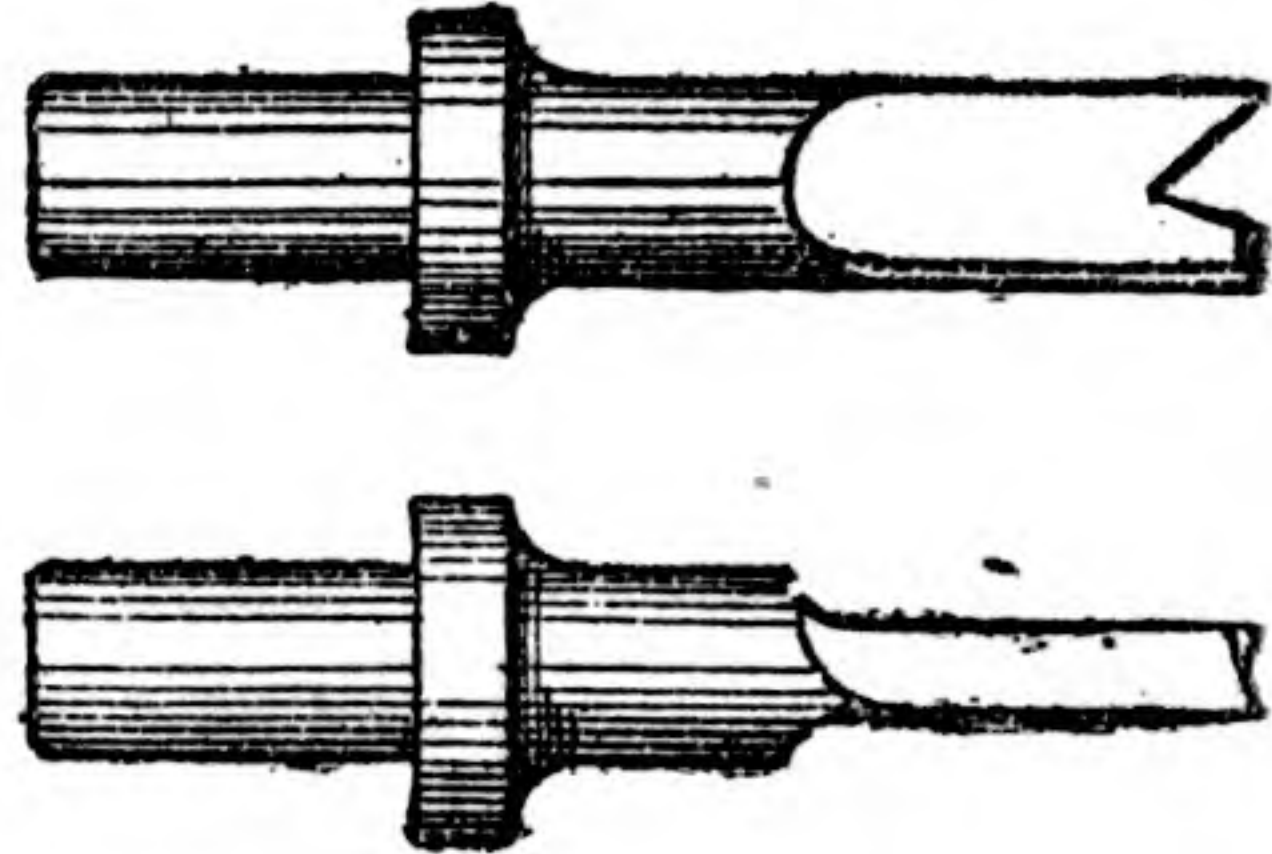

Fig: 3

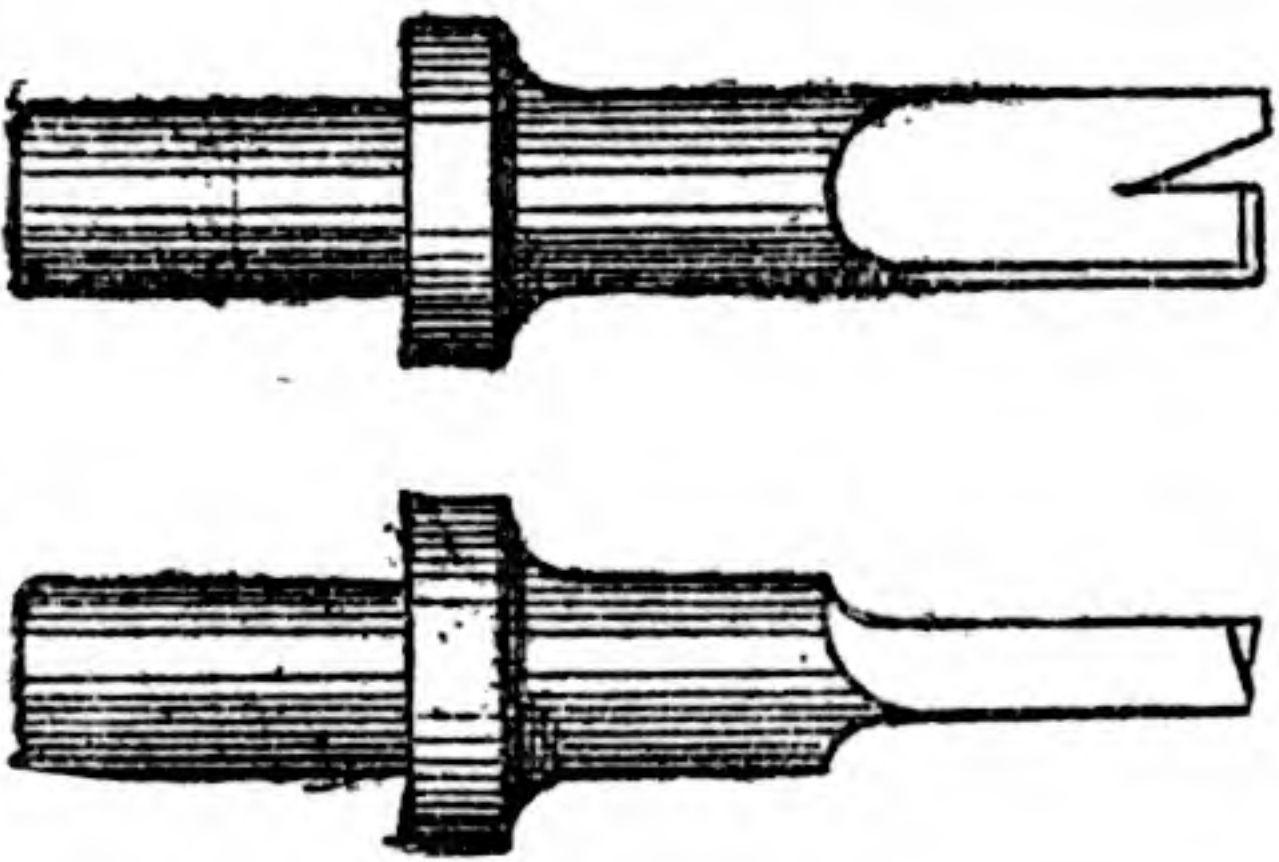

Fig: 4

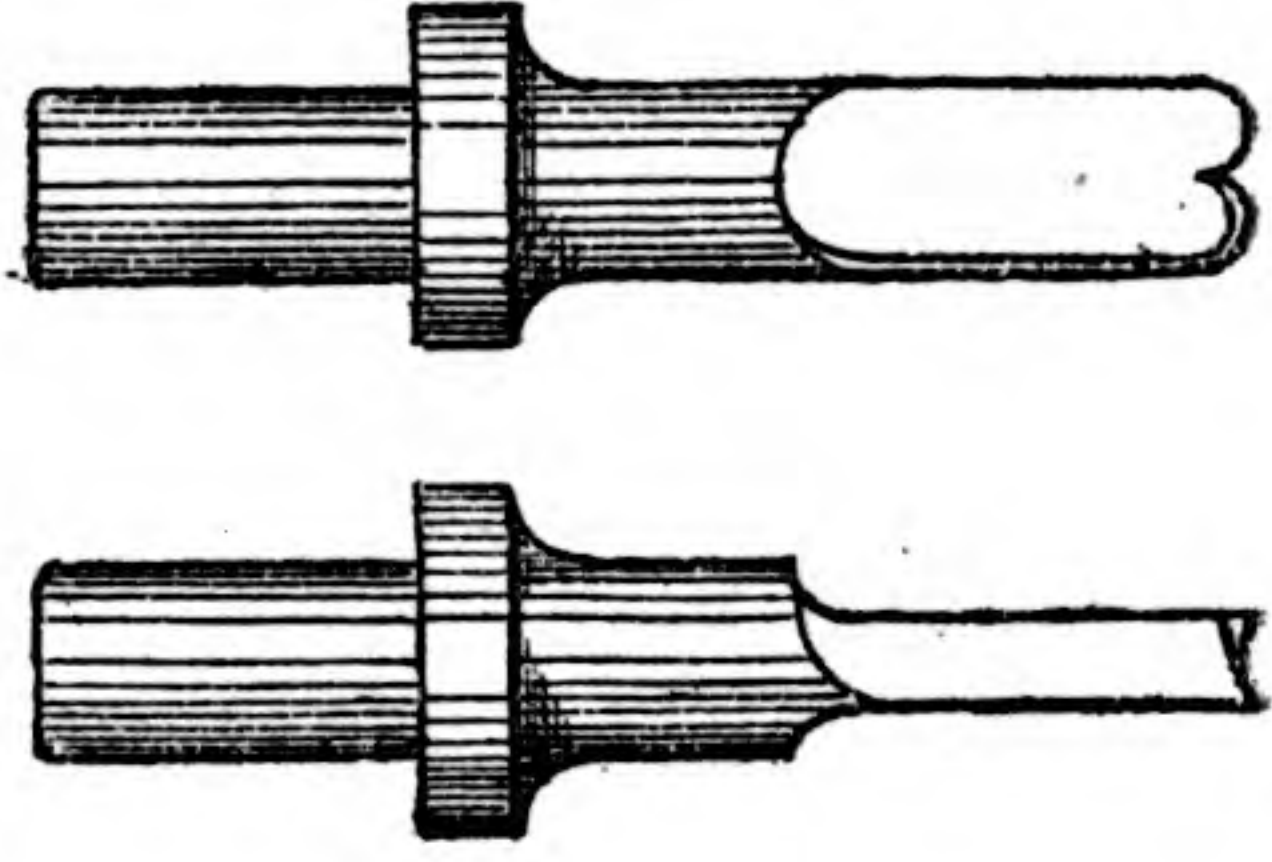
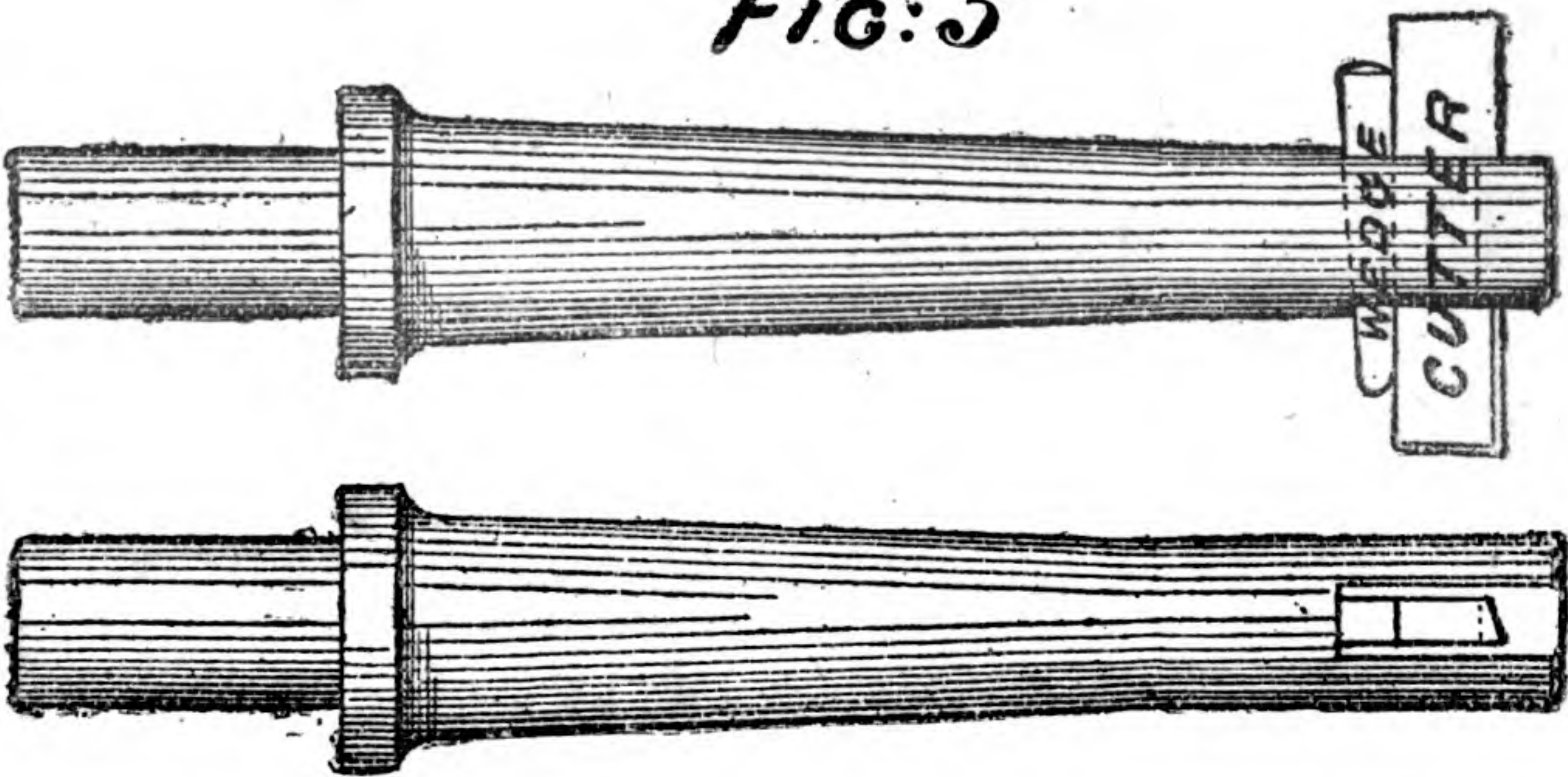

Fig: 5



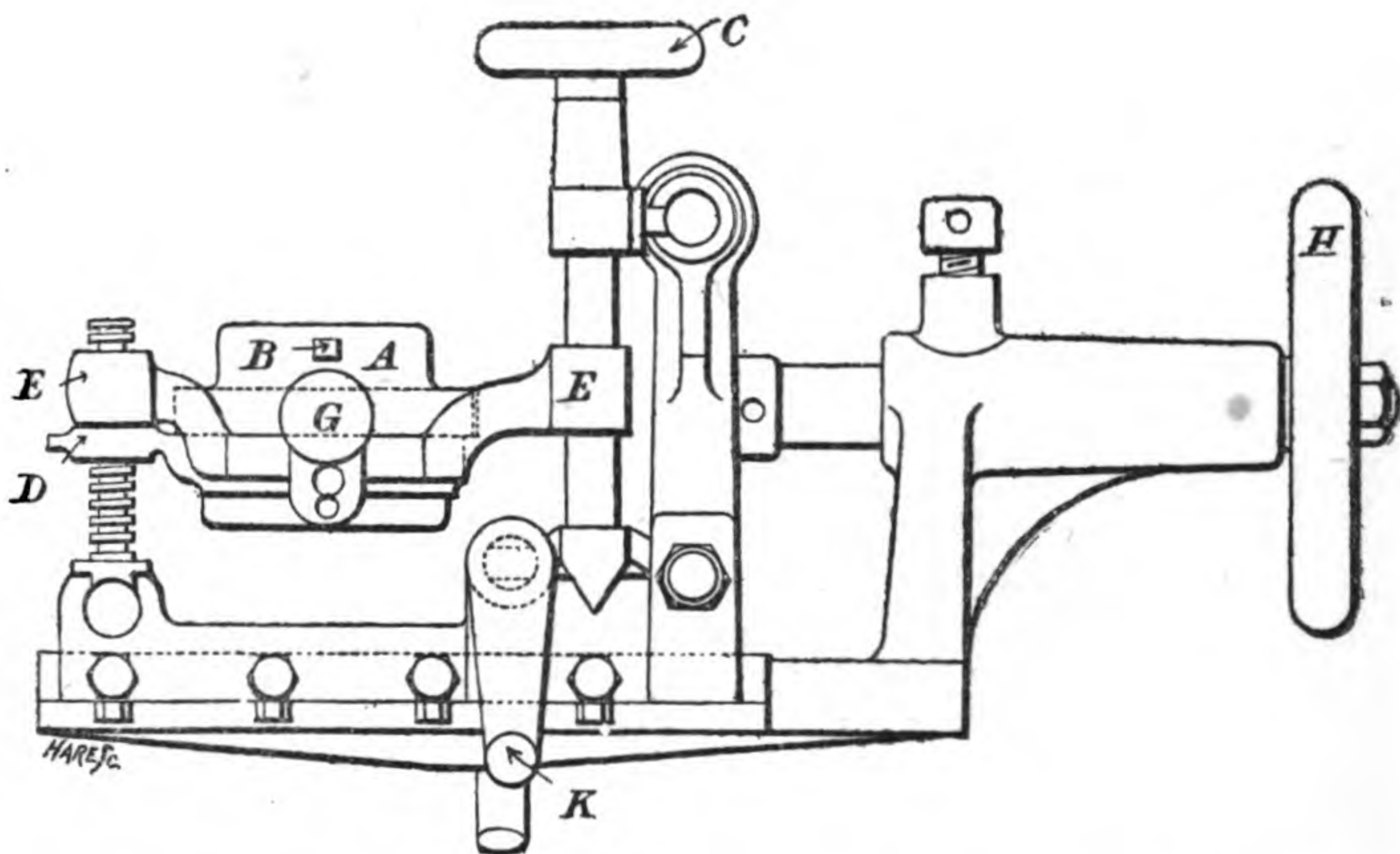
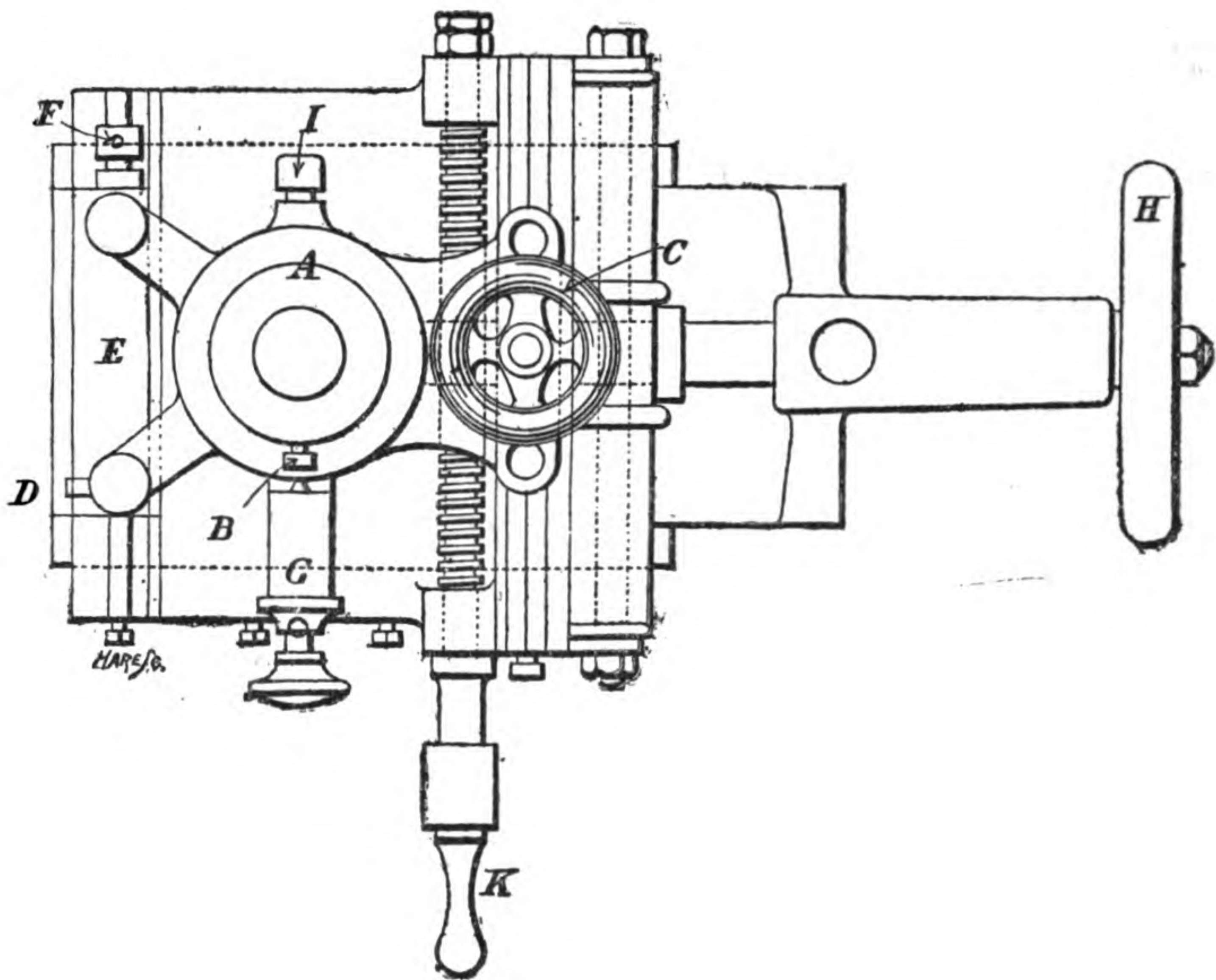

PLATE XVIII.—BRITANNIA COMPANY'S MILLING MACHINE
(GREATORIX PATENT).

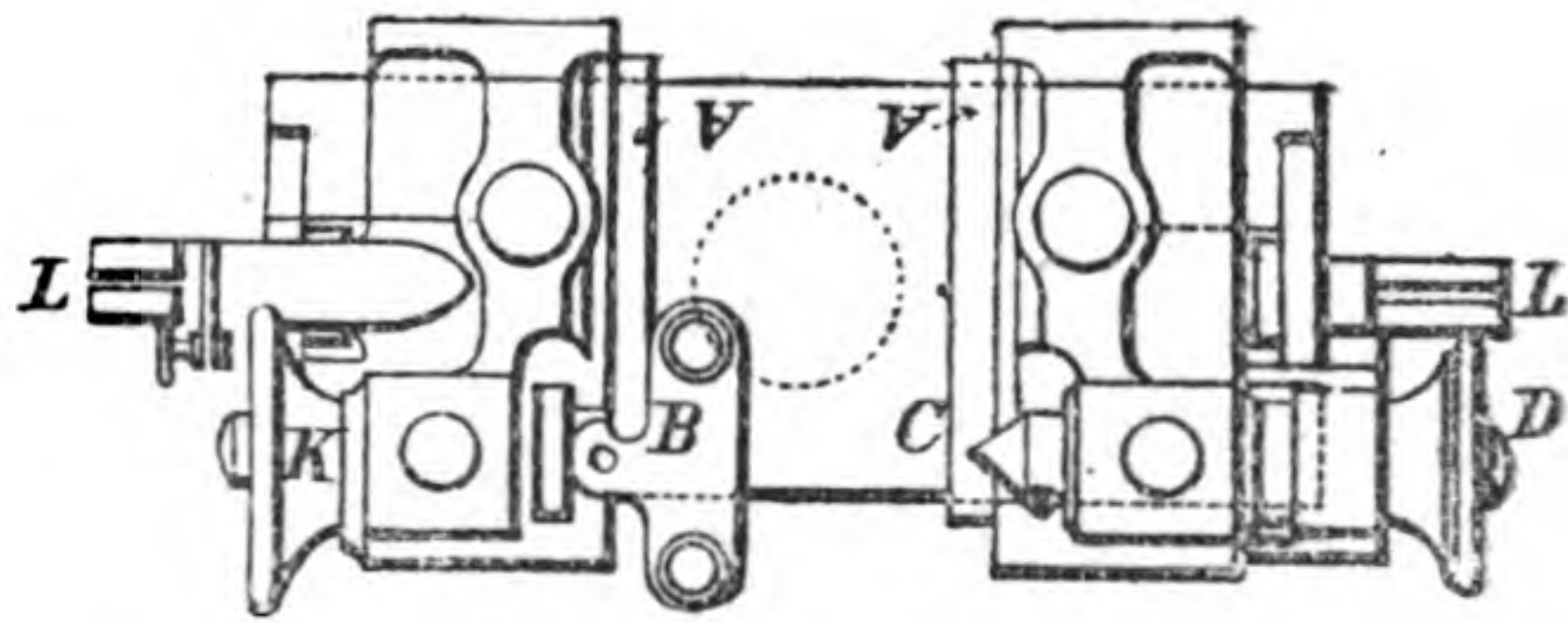
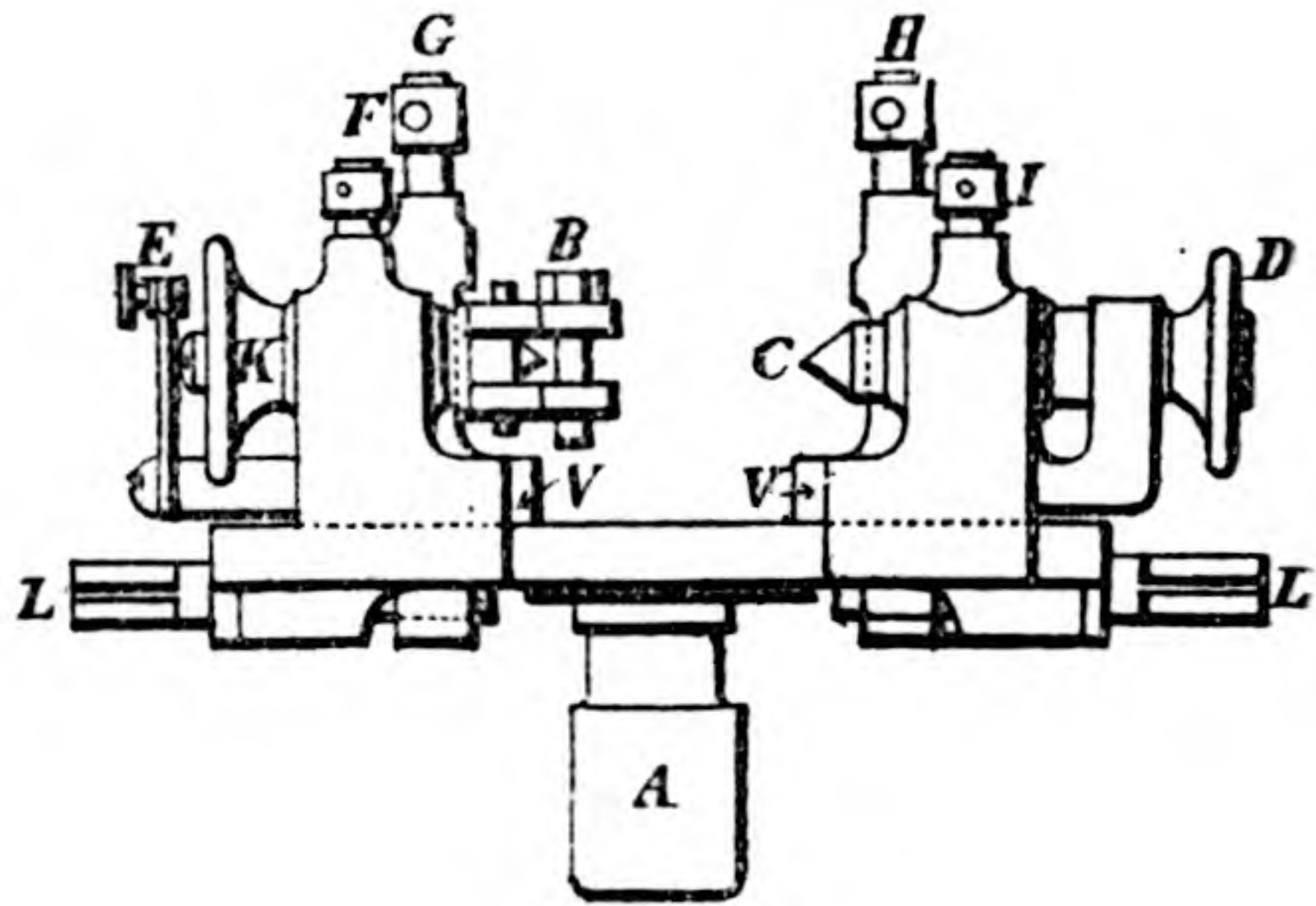
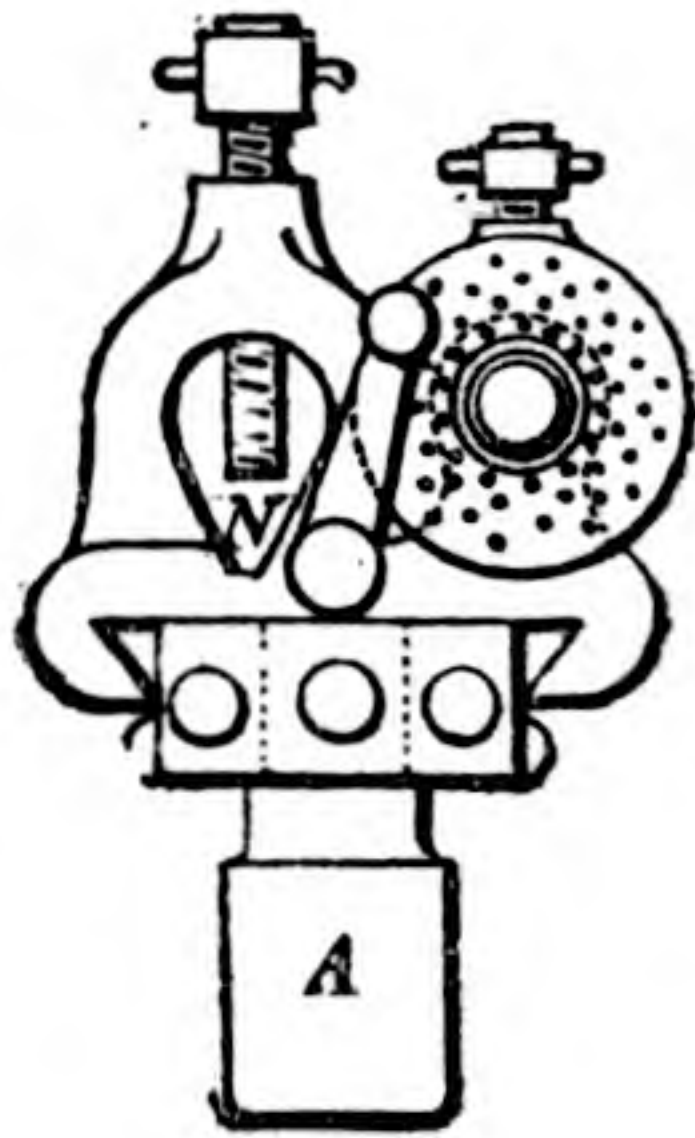

PLATE XIX.—BRITANNIA COMPANY'S MILLING MACHINE
(GREATOREX PATENT).

cut to the gauge by taking equal quantities off two opposite sides of the object to be shaped, and the cut thus set completes the hexagon.

It will be seen at a glance that drilling is performed by merely substituting a drill for the cutter, and the adjustment obtained by the vertical wheel (C) and the handle (K), the feed being given by the horizontal wheel (H.)

These two processes represent the principle upon which an endless variety of ornamental work in hard wood or metal can be executed, the cutting edge of the tool being turned to the required pattern; always remembering, if the work is concave, to turn the tool convex; and so on, with reference to mouldings and raised or sunk forms, and with perforations for drilled designs and coronas for lids, and the many methods of ornamenting turned work, bounded only by the taste of the operator.

Before fixing the combination chuck in the socket (A) of the apparatus (Plate XIX.), see that the set-bolt (B) faces the head-stock of the lathe, also that the spring catch is in one of the division holes, and the set-bolt (I) securely tightened; the chuck can now be secured to the socket (A, Plate XVIII.) by the set-bolt (B).

We will now suppose a tap is to be fluted. Place the tap between the centres (C), securing it by the clamps (B), tightening up by the screw (D). A round-nose tool (Fig. 4, Plate XVII.) is used, and the centre line of the tap adjusted to the centre of the tool; or if the tap is a little below the centre of the tool, it gives a more decided cutting edge, thus, J (one size tool will do several sizes of taps). Engage the spring catch (E) with the requisite series of division holes in disc (K), and traverse the tap to the tool by the handle (K, Plate XVIII.) until the flute is the required depth, then set it by the division holes for the next groove, and so on, until the job is completed.

We will now suppose a slot is to be cut in a rod. Place the rod in the V gap, fasten down by the screws G. H.; use a tool (Fig. 2, Plate XVII.). It is best to drill a hole at the two extremes of the length of the slot required. Let the centre line of the rod be exactly opposite the centre of

the tool; then traverse as in fluting. For key-way cutting, see that the tool is shaped like Fig. 3 (Plate XVII.).

To use the chuck as a vice, remove the clamps (B) by withdrawing the screws, and then objects can be gripped for shaping, drilling, boring, or any other operation within the range of the apparatus.

Fig. 5, Plate XVII., is a convenient tool for boring; a small cylinder can be gripped in the vice and bored with accuracy by following the lines already given, but it is not well to stop until the cut is through.

The remarks already offered concerning Ornamental Work apply even more forcibly to the use of the combination chuck.



INDEX.

- A.
- Apparatus for screw chasing, 42
- Articles of square section, turning,
101
- B.
- Back-gear'd lathe, with gap for
metal, 63
- Bar, Haydon, 72
- Beads and mouldings in hard wood,
turning, 38
- Bed of lathe, 2
- Boring-collar, 31
- Boxes, turning, 25
- Boxwood, turning, 34
- C.
- Change wheels, tables of, 112
- Chisel, using the, 19
- Choosing a lathe, 121
- Chuck, Essex, 10
- for turning articles of square
section, 102
- jeweller's, 4
- self-centreing scroll, 6
- self-centreing wood, 13
- Chuck-making, 96
- in metal, 98
- in wood, 96
- Chucks, 5
- Circles, interlacing, 146
- Cutter, eccentric, 144
- grinding top face of, 76
- how to grind, 74
- Cutters, how to obtain correct
angles for, 75
- Cutting screws in wood by hand
chaser, 40
- Cylinder in hard-wood, turning, 37
- turning a, 32
- D.
- Description of lathe, 2
- Double edges, principle of, 69
- Drilling, 141
- instrument for ornamental
work, 138
- Drills for ornamental work, 139
- E.
- Eccentric cutter, the, 144
- Essex chuck, 10
- F.
- Face plate, 9
- G.
- Gauges, use of, 27, 28
- Gouge, using the, 15
- Greatorex milling machine, 150
- Grinding cutters, 73
- tools, 124
- top face of cutter, 76
- H.
- Hand chaser, cutting screws in
wood by, 40
- tools, metal-turning with, 53
- Hard-wood turning, 34
- turning, tools for, 34

- Haydon bar, 72
Hollow ware, turning, 20
- I.
- Interlacing circles, 146
- J.
- Jeweller's chuck, 4
- L.
- Lathe, description of the, 1
Loose cutters, principle of, 72
- M.
- Mandrel, 2
 modern screw, 51
 traversing, 49
- Metal, chuck-making in, 98
 slide-rest work in, 63
- Metal-spinning, 129
 lathes for, 133
 shapes for, 130
 tools for, 129
- Metal-turning, tools for, 54
 with hand tools, 53
- Micrometer guide, Britannia Company's patent, 109
- Milling machine, Greatorex, 150
- Miniature screw-cutting lathe, 88
- Modern screw mandrel, 51
- O.
- Oil for lathe, 2
- Ornamental work, 138
 work, drilling instrument for, 138
 work, drills for, 139
 work, eccentric cutter for, 144
- Overhead lathe, 89
 lathe, uses of the, 115
- P.
- Plankway of the grain, turning, 39
- Poppet, back, 5
- Prices of lathes, 122
- Principle of double edges, 69
 of loose cutters, 72
- S.
- Screw-chasing apparatus, 42
- Screw-cutting by self-acting lathe, 91, 104
 lathe, 88
 preparing work for, 110
- Self-acting lathe, 80
 lathe, screw-cutting by, 104
- Self-centreing scroll chuck, amateur's, 6
 wood chuck, 13
- Set of tools for slide-rest, 70
- Setting tools, 124
- Shaping work with eccentric cutter, 148
- Slide-rest, small, 65
 strong compound, 65
 work, how to use tools for, 67
 work in metal, 63
 W. S. Brown's, 63
- Solid forged tools for slide-rest work in metal, 67
- Square section, turning articles of, 101
- Squaring cylinder by eccentric cutter, 147
- Stand for tools, 71
- T.
- Tool-handles, turning, 14
- Tools for metal-spinning, 129
 for metal-turning, 54
 for slide-rest, set of, 70
 for slide-rest work in metal, 66
 for turning hard-wood, 34
 for turning ivory, 34
 grinding, 124
 how to use, 14
 setting, 124
 solid forged, 66
 stand for, 71
 turning, 14
- Traversing mandrel, use of, 49
- Treble-gear lathe, 87
- Triangular section, turning articles of, 103
- W.
- Wood, chuck-making in, 96

MODEL * STEAM * ENGINES,

Cylinders, Pumps, Steam and Water Gauges, Safety Valves, Eccentrics, Taps, &c.

CUTTERS, SCHOONERS, BRIGS,

BLOCKS, DEADEYES,

Fittings for Model Ships (list free), Chemical Chests, Microscopes, Telescopes,
Magic Lanterns, Balloons, Scientific Novelties, &c.

STEVENS' MODEL DOCKYARD,

22, ALDGATE, LONDON.

SEND 3d. FOR ILLUSTRATED CATALOGUE, 100 ENGRAVINGS.

❁ **W. * WRAY,** ❁
OPTICIAN,

Manufacturer of Telescopes, Microscopes, and Photographic Lenses.

ILLUSTRATED CATALOGUE, ONE STAMP.

LAUREL HOUSE,

North Hill, Highgate, London, N.

 *Notice to Engineers & Mechanics.*

THE BRITANNIA COMPANY are
prepared to manufacture Special
TOOLS or parts of **MACHINERY**
to Drawing.

Address—**BRITANNIA WORKS,**
Colchester, England,

*Makers of Engineers' Tools to the British
Government.*

Workshop Receipt Series.

Crown 8vo, Cloth, with numerous Illustrations, Price 5s.

WORKSHOP RECEIPTS,

FOR THE USE OF

Manufacturers, Mechanics, & Scientific Amateurs.

BY ERNEST SPON.

CONTENTS:—Bookbinding, Bronzes, Candles, Cement, Cleaning, Concretes, Dyeing, Electro-Metallurgy, Enamels, Engraving, Etching, Firework-making, Freezing, Fulminates; Furniture Creams, Oils, Polishes, Lacquers, and Pastes; Gilding, Glass-cutting, Graining, Gums, Ink, Japans, Matches, Paper-hanging, Painting in Oils, Photography, Polishes, Pottery, Silvering, Soap, Solders, Taxidermy, Varnishes, Veneering, Whitewashing, &c., &c.

Crown 8vo, Cloth, with numerous Illustrations, Price 5s.

WORKSHOP RECEIPTS

(SECOND SERIES).

BY ROBERT HALDANE.

DEVOTED MAINLY TO SUBJECTS CONNECTED WITH CHEMICAL MANUFACTURES.

An entirely New Volume. Uniform in Size, Style, and Type with the Original "Workshop Receipts."

CONTENTS:—Acidimetry and Alkalimetry, Albumen, Alcohol, Baking-Powders, Bitters, Cements and Lutes, Cleansing, Confectionery, Copying, Disinfectants; Dyeing, Staining, and Colouring; Essences, Extracts, Fireproofing, Glue and Size, Glycerine, Gut, Hydrogen Peroxide, Inks, Iodine, Iodoform, Isinglass, Luminous Bodies, Magnesia, Matches, Paper, Parchment, Pigments, Paint, Preserving.

Crown 8vo, Cloth, with numerous Illustrations, Price 5s.

WORKSHOP RECEIPTS

(THIRD SERIES).

BY C. G. WARNFORD LOCK, F.L.S.

DEVOTED MAINLY TO ELECTRICAL AND METALLURGICAL SUBJECTS.

Crown 8vo, Cloth, Price 5s.

WORKSHOP RECEIPTS

(FOURTH SERIES).

BY C. G. WARNFORD LOCK, F.L.S.

DEVOTED MAINLY TO HANDICRAFTS AND MECHANICAL SUBJECTS.

250 Illustrations, with Complete Index, and a General Index to the Four Series.

CONTENTS:—Waterproofing. Packing and Storing articles of delicate odour or colour. Embalming and Preserving. Leather Polishes. Cooling Air and Water. Pumps and Syphons, embracing every useful contrivance for raising and supplying water. Desiccating: air- and water-ovens, and other appliances for drying natural and artificial products. Distilling: essences, perfumes, and alcoholic liquids. Emulsifying. Evaporating. Filtering. Percolating and Macerating. Electrotyping. Stereotyping. Bookbinding. Straw Plaiting. Musical Instruments: the preservation, tuning, and repair of pianos, harmoniums, musical boxes, &c. Clock and Watch Mending. Photography: recent development in rapid processes, &c., &c.

E. & F. N. SPON, 125, Strand, London.

BRITANNIA COMPANY,

Tool * Makers,

100, HOUNDSDITCH, LONDON.

Lathe No. 6.



This Lathe has been designed to meet the demand for a low-priced tool, PROPERLY CONSTRUCTED and accurate.

Those who have seen and examined it pronounce it to be SUPERIOR TO ANY OTHER yet introduced.

It has a planed iron bed, 20in. long; 2½in. centre heads, which can easily be blocked up to 4in. for wood turning; will admit 1in. between centres. It is fitted with a well-designed stand with a turned fly-wheel, 19in. diameter.

Each Lathe has a spanner, hand rest, and two tees, driver chuck and centres, drill chuck, and fork centre for wood.

The "catchplate," shown in illustration, has been replaced by a more convenient "driver chuck."

Price, complete £2 15s.

Slide Rest to Suit, £2.

Even this, our Cheapest Lathe, has a Conical Mandrel.

Beware of so-called Cheap Lathes, which have no provision for taking up wear.

BRITANNIA WORKS, COLCHESTER, ENGLAND.

No. 2 AND 3 LATHES.

Suitable for Amateurs, Jewellers, Dentists, or any light use.

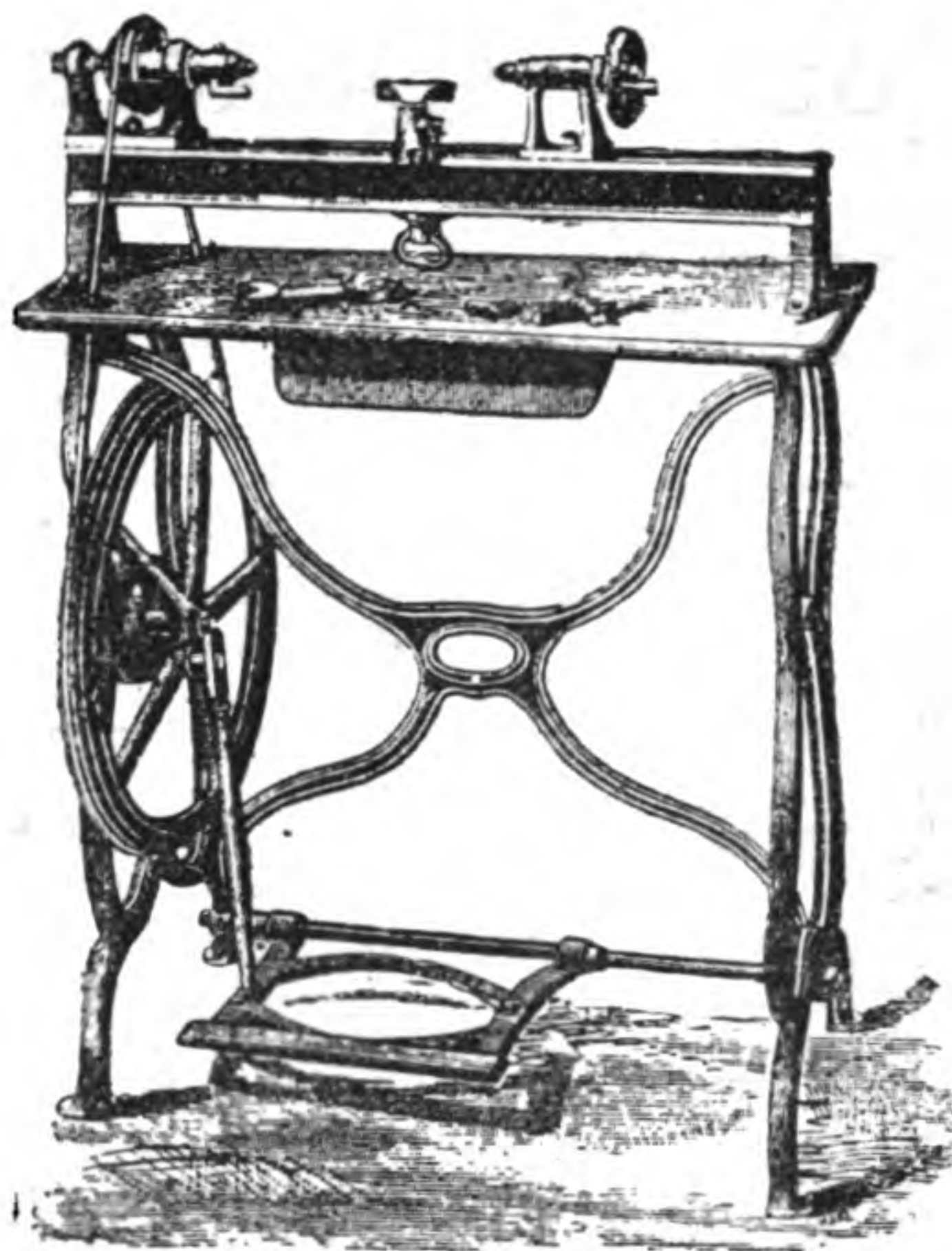

No. 2.

24in. bed, 2½in. centres, turning 14in. long by 5in. in diameter.

	£	s.	d.
Price without Stand, as Bench Lathe only	1	15	0
Or with Stand, Fly-wheel, and Treadle complete	3	10	0
Foot-power Motion, with Treadle and Frame, and 14in. Fly-wheel, as illustration above	1	0	0

No. 3.

30in. bed, 3in. centres, turning 18in. long by 6in. in diameter.

Price without Stand, as Bench Lathe only	2	5	0
Or with Stand, Fly-wheel, and Treadle complete	4	5	0
If with Gap Bed, extra	0	10	0
Foot-power Motion, with 20in. Fly-wheel, Treadle and Frame, as illustrated above	1	10	0

First-class well-finished Lathes with machine-planed iron bed ; headstock has steel mandrel with conical neck and adjusting screw and lock nut to take up wear ; 3-speed bright turned cone pulley ; hardened centres, driver chuck, cylinder mandrel with square thread traverse screw to tail stock, hand rest and two tees. Substantial iron stand, with polished wood top and tool drawer, turned speed fly-wheel, and easy treadle motion.

Circular saws, emery and buff wheels, can be used in these Lathes.

Fret Sawing Appliance to suit the No. 3 Lathe, which attaches very easily to bed, and is driven by the Lathe, price £1 10s.

NOTICE.—This Lathe is now fitted with Stand as No. 6, but stronger. Weight, complete, 128lb.

BRITANNIA WORKS, COLCHESTER, ENGLAND.

LATHES BACK-GEARED.

No. 3.

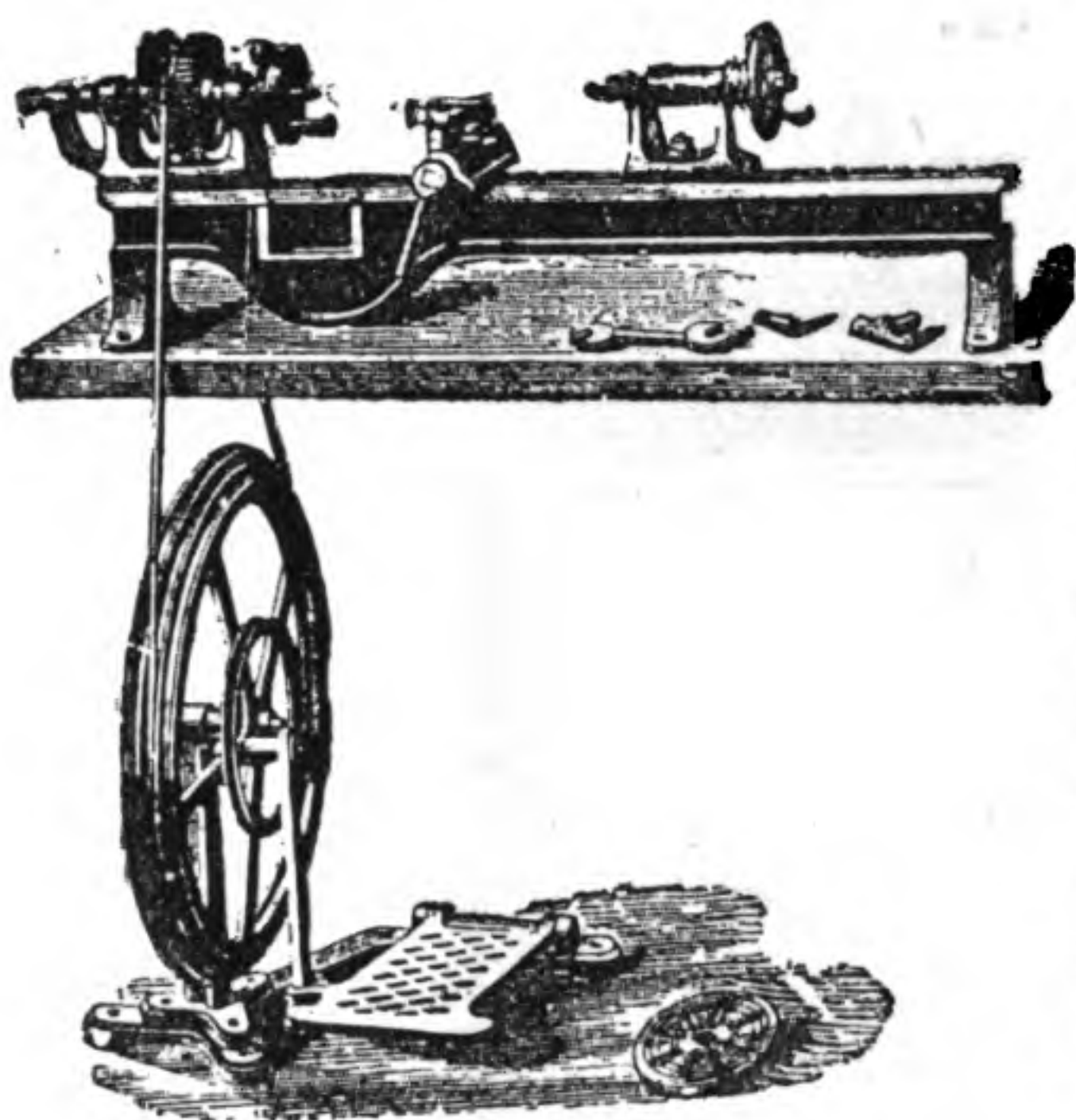

A first-class, well-finished Lathe, with machine-planed iron bed, plain or with gap; back-geared headstock, cast steel mandrel, conical necks, tail pin running through; adjusting screw and lock nuts to take up wear; 3-speed bright turned cone pulley; steel centres; tailstock with cylinder mandrel, square thread traverse screw; eccentric hand rest and 2 tees and catchplate as shown.

Bed 30in. long, and 3in. centres, turning 18in. by 6in.

	£	s.	d.
Price without Stand, as Bench Lathe only, with back-geared headstock	4	0	0
Ditto, with back gear and gap bed	4	10	0
Ditto, with 3ft. gap bed like No. 13 lathe, extra	1	0	0
Face Plate, to suit 5½in. diameter	0	10	0
Slide Rest to suit	2	10	0
Foot Power Motion, to fix under Bench, with 4-speed turned fly wheel, 20in. diameter, treadle and frame complete, as illustrated	1	10	0
Substantial Iron Stand complete, with polished wood top and tool drawer, 4-speed turned fly-wheel, 20in. diameter, treadle, &c.	2	0	0
Ditto, of a heavier make, with very heavy fly wheel, as shown with No. 13 Lathe	2	10	0
Lathes fitted with extra hardened mandrel and collars, extra	1	10	0
Ditto, division plate and steel index	1	10	0

Can also be fitted with Fret Sawing Appliance, Circular Saws, Emery and Buff Wheels, &c.

ADVERTISEMENTS.

NEW
SINGLE GEARED LATHE.

No. 8.

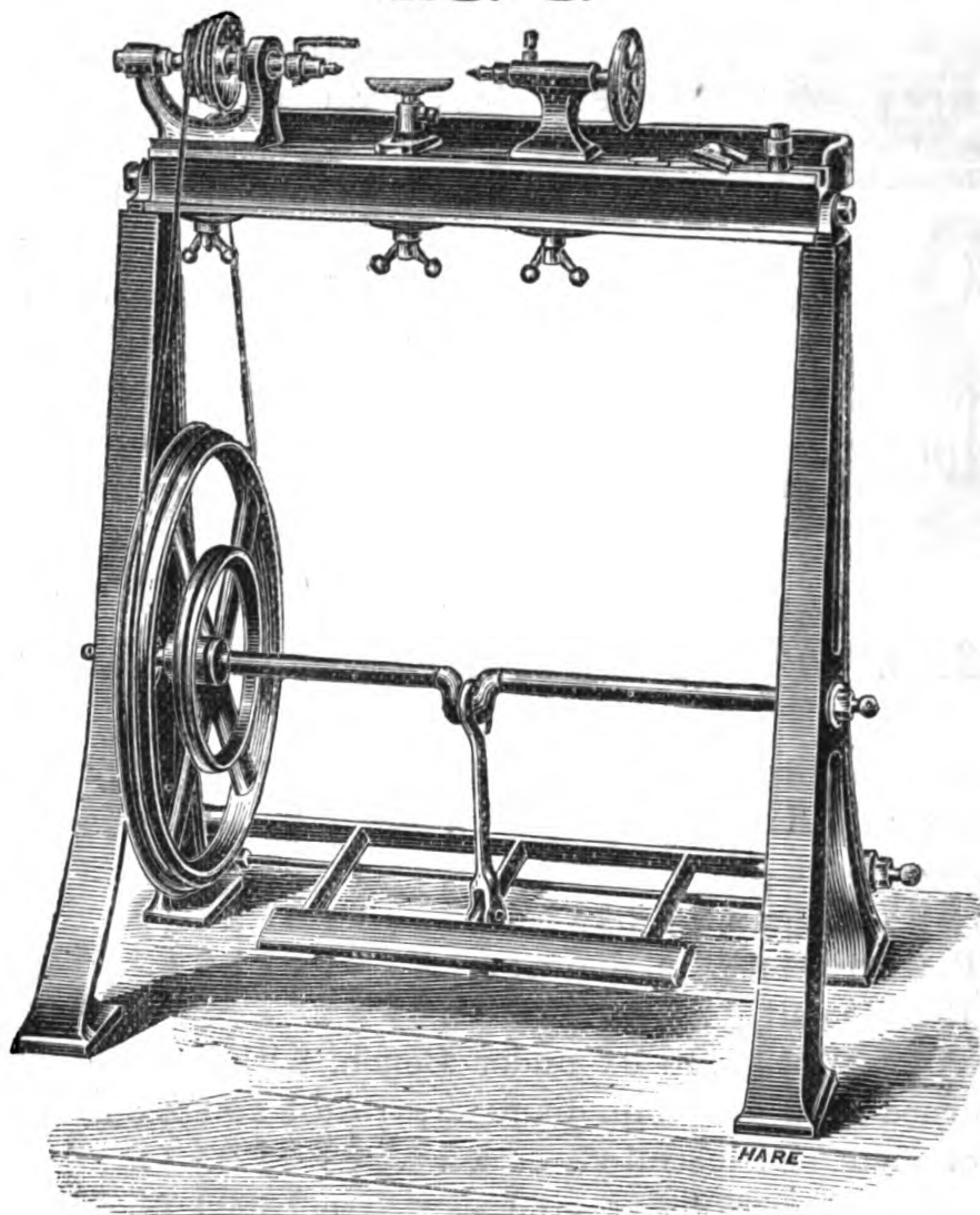

3½ in. Centres. 2ft. 6in. Bed.

WILL TAKE 16½ INCHES BY 7 INCHES BETWEEN CENTRES.

THE above is introduced to supply a demand for a Lathe coming between our No. 3 and No. 4 patterns. It is fitted with gunmetal mountings, and it can be recommended with confidence for general light turning, and for amateurs, clock-makers, &c.

It is thoroughly well made, and very light running. The fast head is fitted with best steel mandrel and best steel collar, both hardened, 4-speed turned cone pulley, nose 5/8 in. Whitworth; the loose head has steel cylindrical spindle, square thread traverse screw, best steel centres, hand rest and 2 tees, machine-planed cast-iron bed, 3½ in. face, 3 in. deep, securely bolted to cast-iron standards; wrought-iron crank shaft and treadle, working on steel centres, turned speed fly-wheel, tool board, leather driving cord, driver chuck, drill chuck, &c., complete. WEIGHT, 180lb.

Price ... £6 10s., or with 3ft. Bed, £7.

BRITANNIA WORKS, COLCHESTER, ENGLAND.

IMPROVED FOOT LATHE.

No. 4.

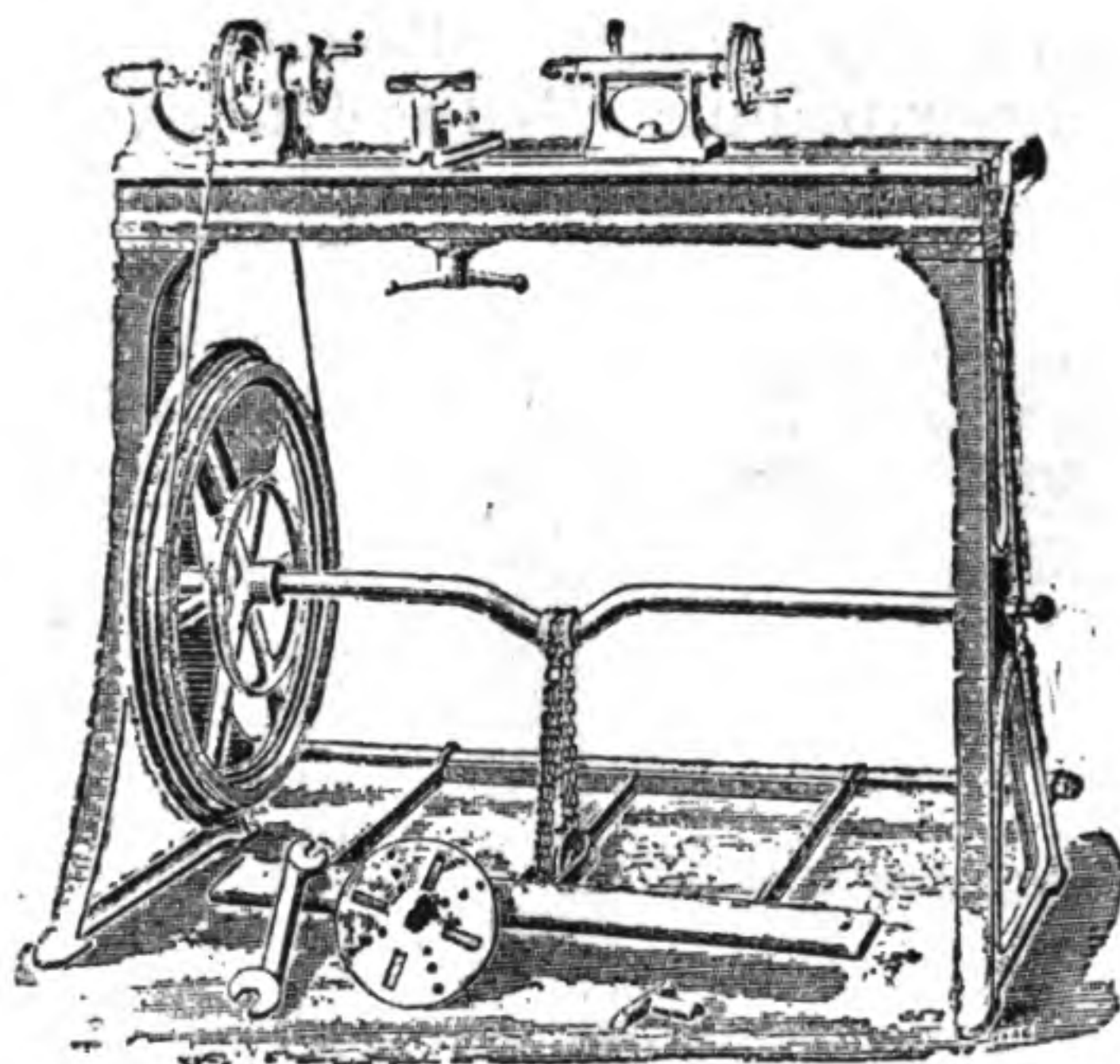

THIS illustration represents an excellent Foot Lathe especially suited for Gas Fitters, Jewellers, Dentists, or Amateurs.

It has a machine-planed iron Bed, 3ft. long, on strong iron standards, with 4-speed turned fly-wheel, and an easy, light-running treadle movement.

The single-gear headstock has a steel mandrel, with hard-coned neck running in hard collar.

The back-gear headstock has a steel mandrel, with reverse cones (adjustable to take up wear), and running in gunmetal collars, steel-coned centre, 3-speed turned coned pulley.

The tailstock has cylinder mandrel, with square thread steel traversing screw and steel-coned centre. Each Lathe is accompanied by hand rest, with two tees, two face plates (large and small), two plain centres, spanner, and tool table. The 3ft. Lathe takes 1ft. 6in. between centres.

Slide-rest as per List.

Strength and durability are obtained, in a high degree, without clumsiness.

	£	s.	D.		£	s.	D.
3½in. Centre ..	8	0	0	Back Geared ..	10	0	0
4 „ „ ..	8	10	0	„ ..	10	15	0
4½ „ „ ..	9	0	0	„ ..	11	10	0
5 „ „ ..	9	10	0	„ ..	12	0	0

3ft. 6in. Bed, 10s. extra.

If with Gap Bed and Bridge, £1 extra.

Extra Large Face Plate, to use with Gap Bed, £1.

Extra hardened Mandrel and Collars, 30s. extra.

BRITANNIA WORKS, COLCHESTER, ENGLAND.

IMPROVED FOOT LATHE.

✦ No. 5. ✦

THIS is a similar Lathe to the No. 4, but with heavier Bed, Standards, and Fly Wheel—altogether of a stronger and more substantial description. Bed is 4ft. long and 4½in. on face; total weight of Lathe, about 4½ cwt. It has an Improved Treadle

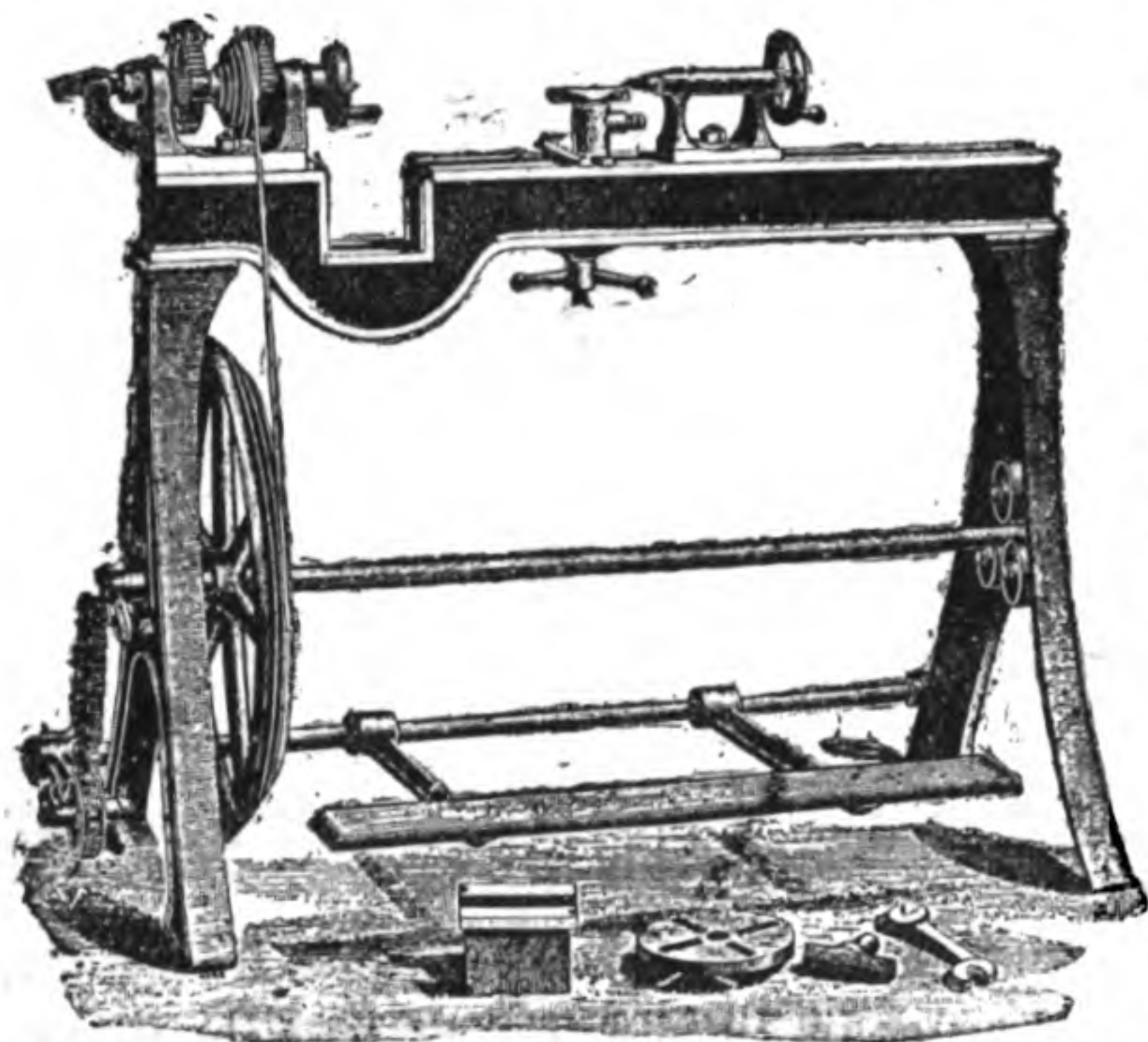

Motion, combining great power with ease of motion; the bright turned shaft on which wheel is keyed runs in Friction Rollers at each end. The Head is fitted with steel mandrel and gunmetal collars. The Crank (as illustration shows) is *outside* the left-hand standard, and is slotted in order that the driving stud may be adjusted to give more or less leverage, to increase or decrease power at will of the operator. The Fly

Wheel is counterbalanced to avoid dead centre.

Each Lathe is accompanied by Hand Rest with two Tees, two Face Plates (large and small), two Plain Centres, and Spanners.

	£	s.		£	s.
4in. Centre ...	11	0	Back Geared ...	13	0
4½ " ...	11	10	" ...	13	15
5 " ...	12	0	" ...	14	10

Gap Bed, £1 extra.

Extra large Face Plate to suit, £1 extra.

A similar Lathe, with 5in. centre, heavier bed, 5½in. on face, 5ft. long, weight about 5½ cwt.—

Single Geared ... £14 Back Geared ... £16;
or with 6ft. Bed, 20s. extra.

Headstocks fitted with extra hard Mandrel and Collars, 30s. extra.

THE ABOVE LATHES CAN BE FITTED WITH HOOKS
AND CRANKS INSTEAD OF CHAINS.

The Lathes with 4ft. Bed will measure 2ft. 4in. between Centres.

BRITANNIA WORKS, COLCHESTER, ENGLAND.

LATHE No. 13.

Improved Self-acting, Sliding, and Screw-cutting Gap Bed Lathe, of superior finish, best material and workmanship.

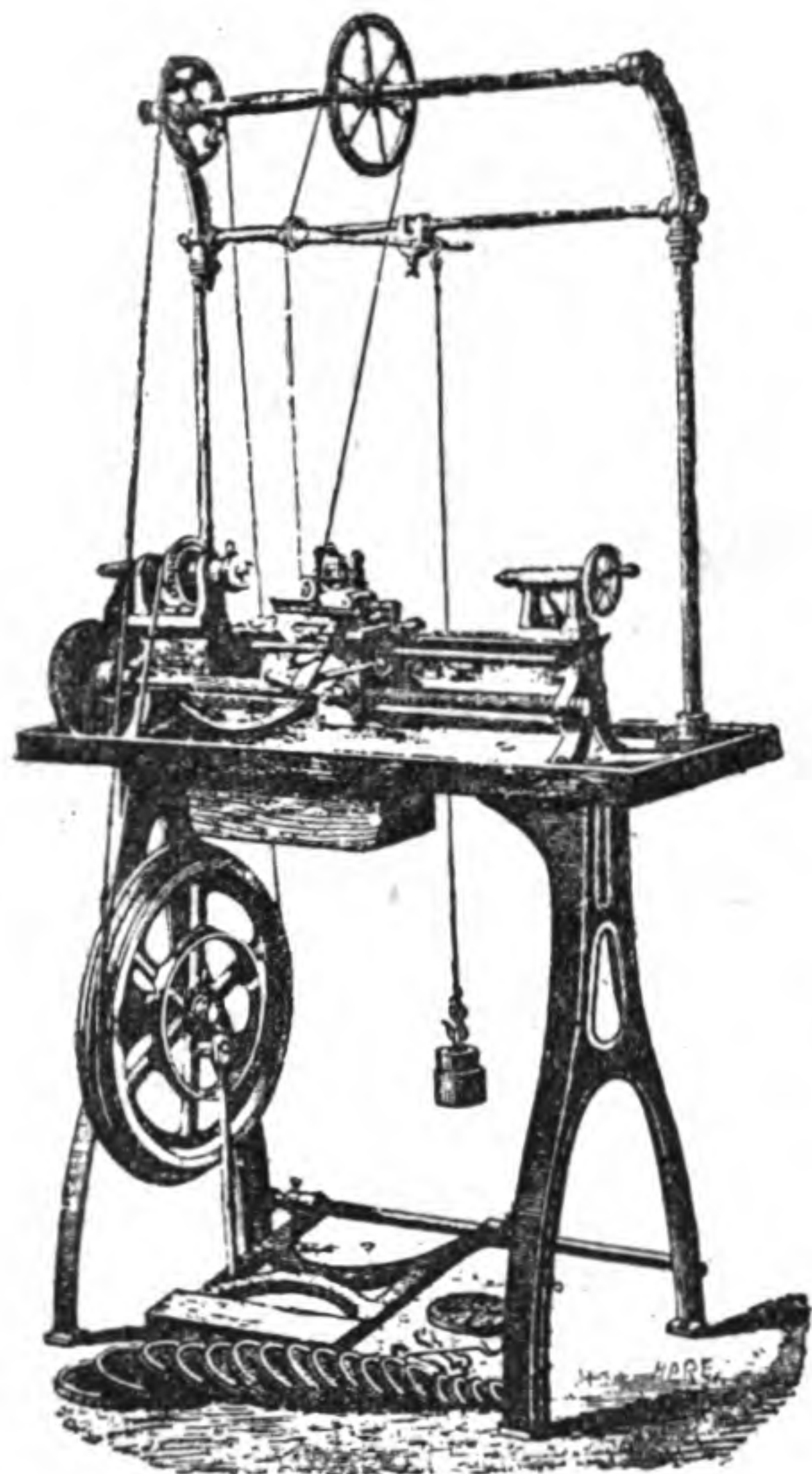

SPECIFICATION.—3in. centre, 30in. gap bed; the headstock is back-gearred, with cast steel spindle, conical necks, steel lock nuts and back centre, coned pulley, turned 3-speeds for gut band, fitted with reversing motion for cutting right and left-hand screws; compound slide rest on carriage, with long bearings accurately fitted and scraped to bed, and well gibbed. The top slide is made swivel, and is graduated to 50° each side of centre to turn cones to any desired angle; strong tool holder with steel screws; tail stock of good design, cylinder mandrel, square thread traverse screw, bright turned hand wheel. The bed (machine planed) is 3½in. on face, 2¾in. deep, with gap 2¼in. deep and 2½in. wide. The leading screw is ⅞in. diameter, ¼in. pitch, accurately cut; the gunmetal nut is in halves to detach, and lathe is fitted with rack and pinion for quick return motion. It has a full set of 22 change wheels to cut screws from one to sixty

threads per inch; it is fitted with face plate, catchplate, steel centres, double spanner, and mounted on an iron stand with polished wood top and drawer; fly-wheel 20in. diameter with 4-turned speeds, treadle motion, &c., complete. Measures between centres 19in., swings 10½in. by 2⅞in. in gap, 6in. over the bed, and 4½in. over the carriage. Total weight about 2¼cwt.

Price complete, 15 Guineas.

Ditto with 3ft. Gap Bed, 16 Guineas.

Overhead Motion for Ornamental Turning, as Illustration, including Drill Spindle, 5 Guineas extra.

BRITANNIA WORKS, COLCHESTER, ENGLAND.

No. 15 LATHE.

*Overhead Motions similar to
that shown on No. 13 Lathe*

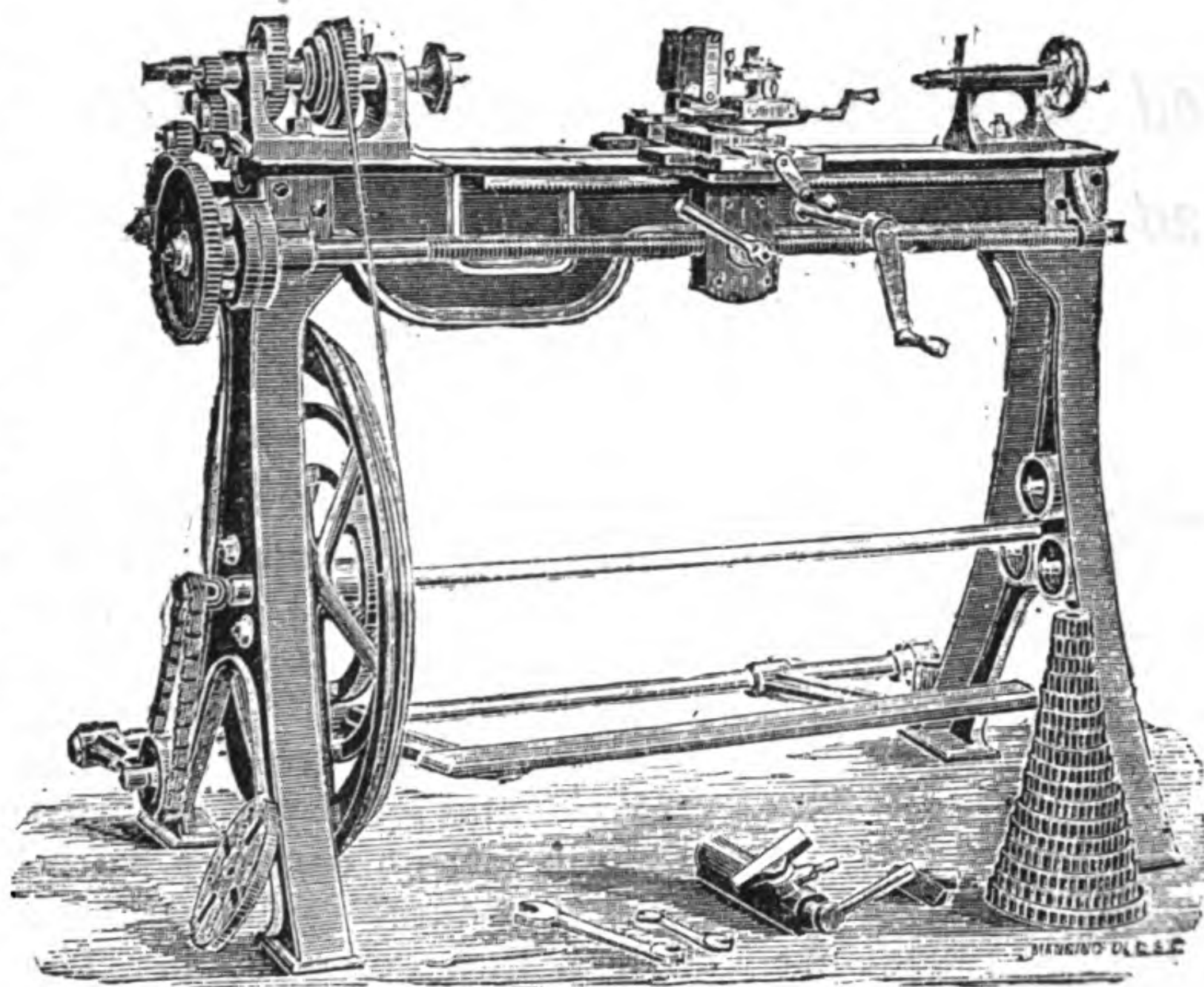

can be fitted to any Lathe.

Self-acting Sliding and Screw-cutting, with 4ft. gap bed, back geared headstock, cast steel mandrel, conical necks running in gunmetal collars, steel lock nuts and back centre, cone pulley, turned 3-speeds for gut band, fitted with reversing motion for cutting right or left-hand screws. Compound slide rest, with long bearings, accurately fitted to bed. The top slide is made to swivel, and is graduated to 50° each side of centre to turn cones to any angle. The tail stock has cylinder mandrel, square thread traverse screw, bright turned hand wheel.

The bed is accurately planed, and is 6½in. wide and 4¼in. deep. The gap is 4¼in. deep. Steel leading screw, 1⅛in. diameter and ¼in. pitch; the gunmetal nut for ditto is in halves to detach. The Lathe is fitted with rack and pinion for quick return. It has a full set of 22 change wheels, to cut from 1 to 60 threads per inch, is fitted with steel centres, face plate, catch plate, double spanner. Strong iron stand, with improved treadle motion, with adjustable outside crank and friction rollers, or with ordinary crank and pitman. The 4ft. Lathe measures between centres 2ft. 6in., swings 1ft. 4in. in gap. The fly wheel is counterbalanced, and has 5 speeds. Weight of 4in. Lathe about 5 cwt.

*These Lathes can be fitted with Overheads for Steam
Power at same price as for Foot Power.*

**Price, with 4in. centre, £25 4s.; 4½in., £26 15s. 6d.;
5in., £28 7s.**

*If Self-acting and Surfacing by leading screw, extra, £4. If with Flat
Speed Pulleys, 21/- extra. Set over Poppet, 30/-.*

BRITANNIA WORKS, COLCHESTER, ENGLAND.

No. 16.
Self-Acting, Sliding, and Screw-Cutting Lathe,

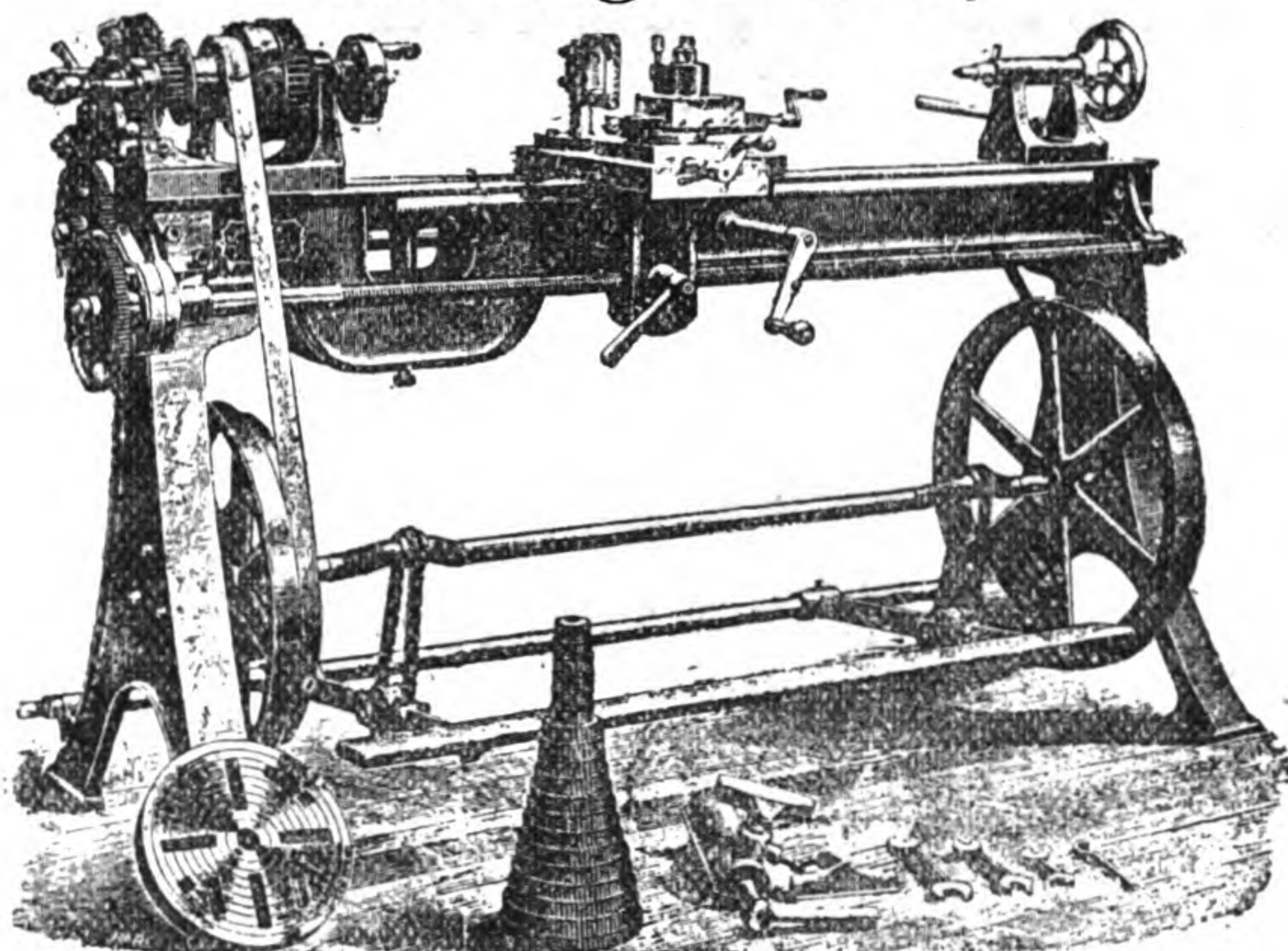

With gap bed accurately planed and surfaced, and bridge piece fitted to gap; double geared headstock; steel spindle with conical neck; gunmetal bearings; reversing motion for cutting right and left-hand screws; the loose head has cylinder barrel and left-hand traverse screw, and made to set over for taper turning if required; steel leading screw accurately cut, and extending full length of bed, with double clam gunmetal nut-gripping screw at top and bottom; saddle with long wings, flush top, and grooved for bolting work to, when boring; quick hand traverse by rack and pinion; compound slide rest to swivel to any angle, graduated for turning conical, and steel draw screws; back following stay; catch and face plates; twenty-two change wheels; index plate; treadle motion; screw keys, &c., &c. All materials and workmanship guaranteed. The 5ft. Lathe measures 3ft. 2in. between centres.

SPECIFICATION.

Breadth of Bed	7 inches.	6in. Cone Pulley, 3	
Depth of Bed	5½ "	speeds	1½ in. broad.
Width of Gap	6½ "	5in. Cone Pulley, four	
Depth of Gap	5½ "	speeds	1⅜ in. broad.
Diameter of Leading Screw .	1¼ "	Large Cone	6½ in. diameter.
Pitch of " " Shaft	¼ "	{ Large Gear	6⅜ in. "
Diameter of Back Shaft . . .	1 "	{ 1¼ in. Broad	7/8 in. pitch.
Change Wheels, 22	¼ in. Pitch.	Body of Spindle	1 in. diameter.

Approximate Weight with 6ft. Bed, 10½ cwt.

Price, Sliding and Screw Cutting, 5in. Centre, 5ft. Bed	- -	£31 10 0
Do. do. 6in. Centre, 6ft. Bed	- -	35 14 0
Extra Length of Bed, per foot	- - - -	2 0 0
<i>If made without Treadle, but with Overhead for Steam Power,</i>		
5in. Centre, 5ft. Bed	- - - -	30 0 0
Do. do. 6in. Centre, 6ft. Bed	- - - -	34 0 0
<i>If Self-acting Sliding, Surfacing, and Screw Cutting (by Back</i>		
Shaft and Leading Screw), extra	- - - -	4 4 0
Poppet to set over, extra	- - - -	1 0 0
<i>If with Cone Speed for Gut Band instead of Flat Belt, deduct</i>	- - - -	1 1 0

The above is of same quality as supplied to the British Government.

BRITANNIA WORKS, COLCHESTER, ENGLAND.

Treble Geared Lathe.

Designed for, and supplied to, the Royal Navy.

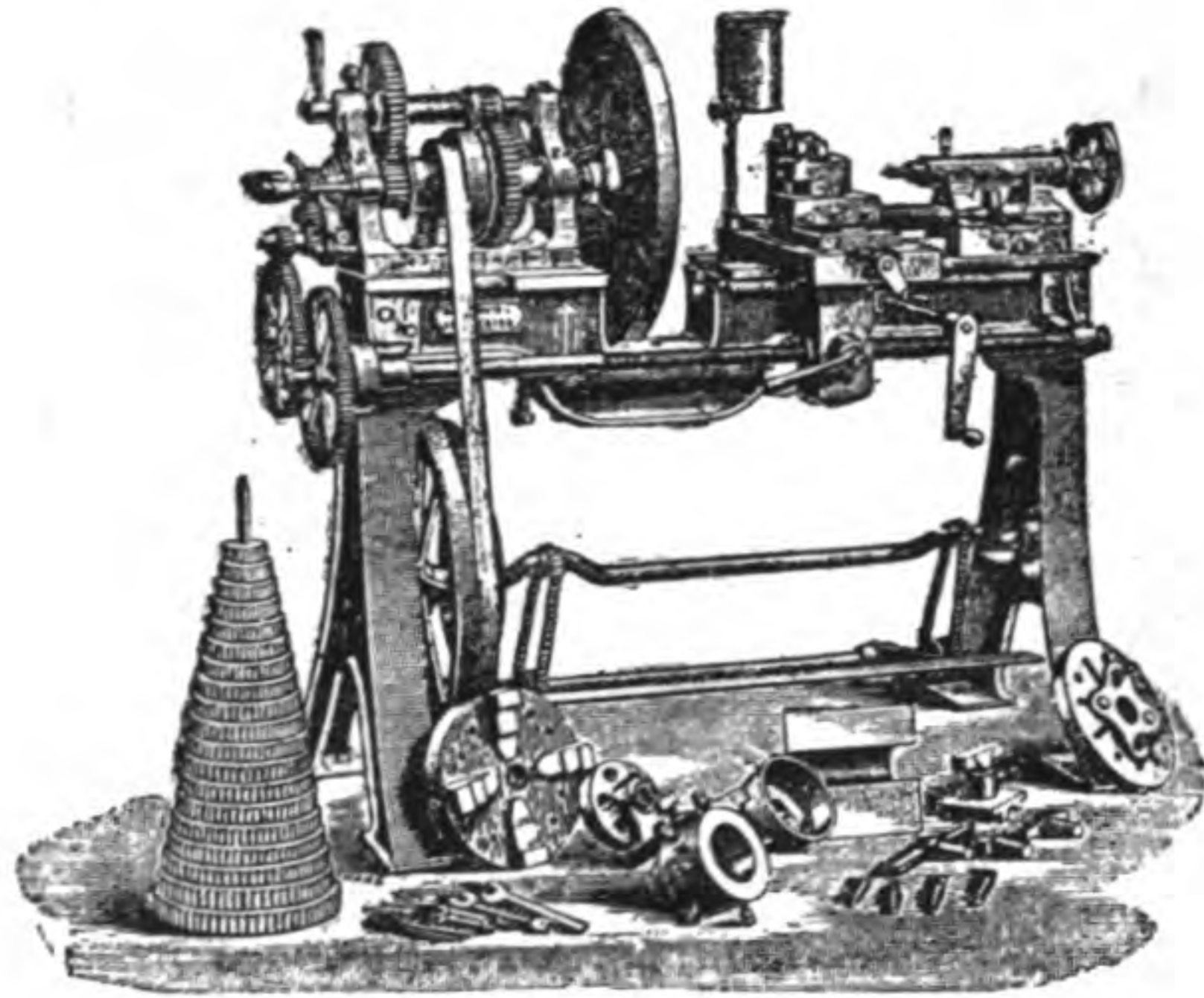

5ft. bed, 5in. centre, £36.

6ft. bed, 6in. centre, £46 10s.

ABOVE Lathes are made for doing extra heavy work by foot power where steam is not available. They are instantly changed from single to double or treble gear.

For Full Particulars, see Catalogue.

BRITANNIA WORKS, COLCHESTER, ENGLAND.

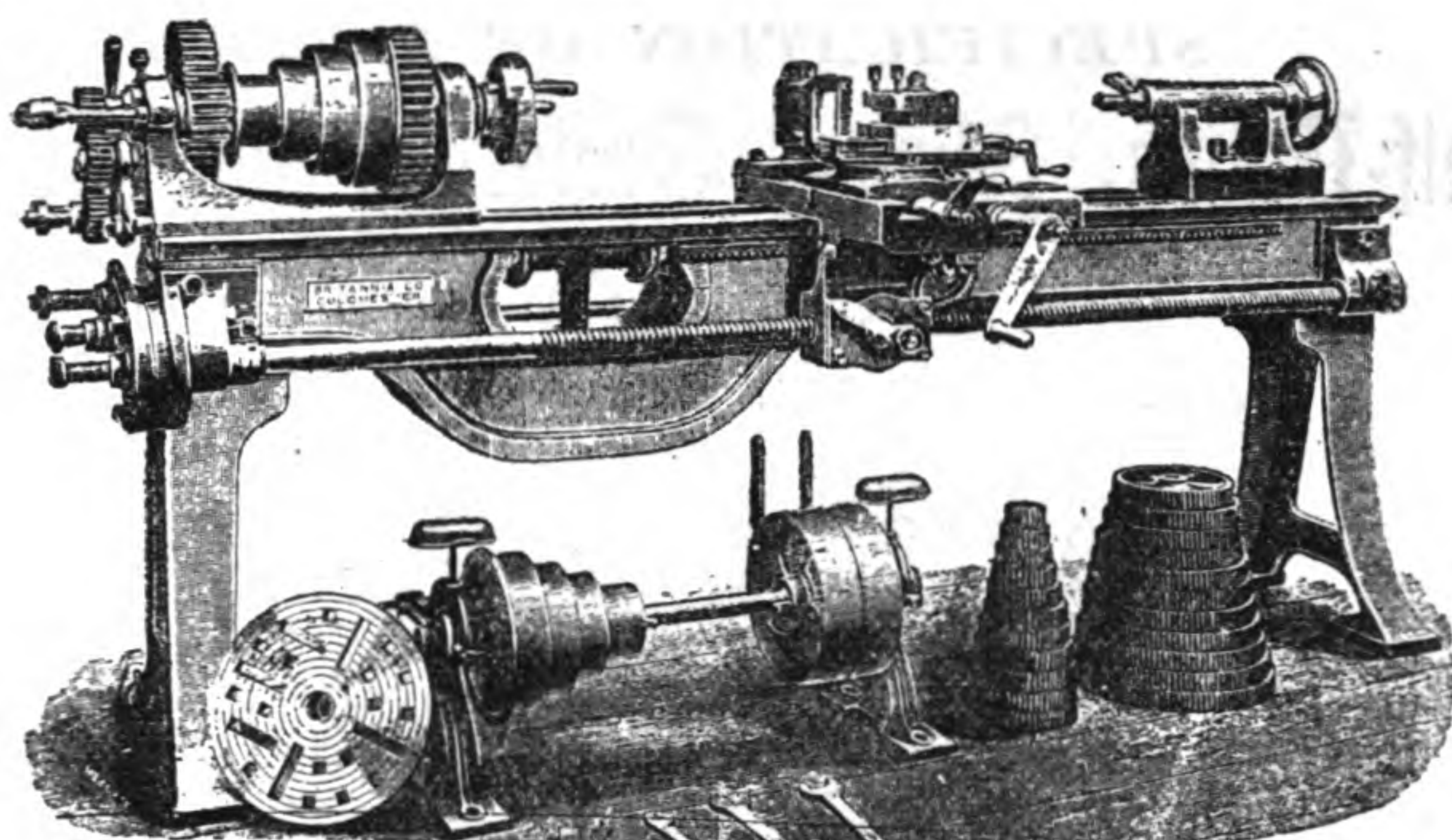

No. 17.—SELF-ACTING SLIDING and SCREW CUTTING LATHE,

6in. CENTRE.

With gap bed accurately planed and surfaced, and bridge piece fitted to gap; double-gear headstock; steel spindle with conical neck; gunmetal bearings; reversing motion for cutting right and left-hand screws; The loose head has cylinder barrel and left-hand traverse screw, and made to set over for taper turning if required; Steel leading screw accurately cut, and extending full length of bed, with double clam gunmetal nut-gripping screw at top and bottom; saddle with long wings, flush top, and grooved for bolting work to, when boring; quick hand traverse by rack and pinion; compound slide rest to swivel to any angle, graduated for turning conical; and steel draw screws; back following stay; catch and face plates; twenty-two change wheels; index plate; overhead motion; screw keys, &c., &c. All materials and workmanship guaranteed.

SPECIFICATION:—

Breadth of Bed, $8\frac{3}{4}$ in.; Depth of Bed, 6in.; Width of Gap, $7\frac{1}{4}$ in.; Depth of Gap, 6in.; Diameter of Leading Screw, $1\frac{1}{2}$ in.; Pitch of Leading Screw, $\frac{1}{4}$ in.; Diameter of Back Shaft, 1in.; Change Wheels (22), $\frac{5}{16}$ in. Pitch; Cone Pulley, 4 speeds, 2in. Broad; Large Cone, $7\frac{3}{4}$ in. Diameter; Large Gear, $8\frac{1}{2}$ in. Diameter; $1\frac{1}{2}$ in. Broad, $\frac{9}{16}$ in. Pitch; Body of Spindle, $1\frac{3}{8}$ in. Diameter. Approximate Weight with 6ft. Bed, $13\frac{1}{2}$ cwt. Admits between centres 3ft. 6in.

	£	s.
Price, Sliding and Screw Cutting	37	16
Price for Self-acting Sliding, Surfacing, and Screw Cutting (by Back Shaft)	44	2
Poppet to set over, extra	1	0
Extra Length of Bed, per foot	2	0
If fitted with Crank Shaft and Treadle Motion instead of Overhead Motion, extra	6	0

Many of the above Lathes have been Supplied to the British Government.

Made also 8in. and 10in. Centres, stronger pattern; 8ft. to 18ft. Beds.

BRITANNIA WORKS, COLCHESTER, ENGLAND.

SPECIFICATION OF No. 22

Self-Acting, Sliding, Surfacing, and Screw-Cutting Lathe,

12in. CENTRE, 12ft. GAP BED.

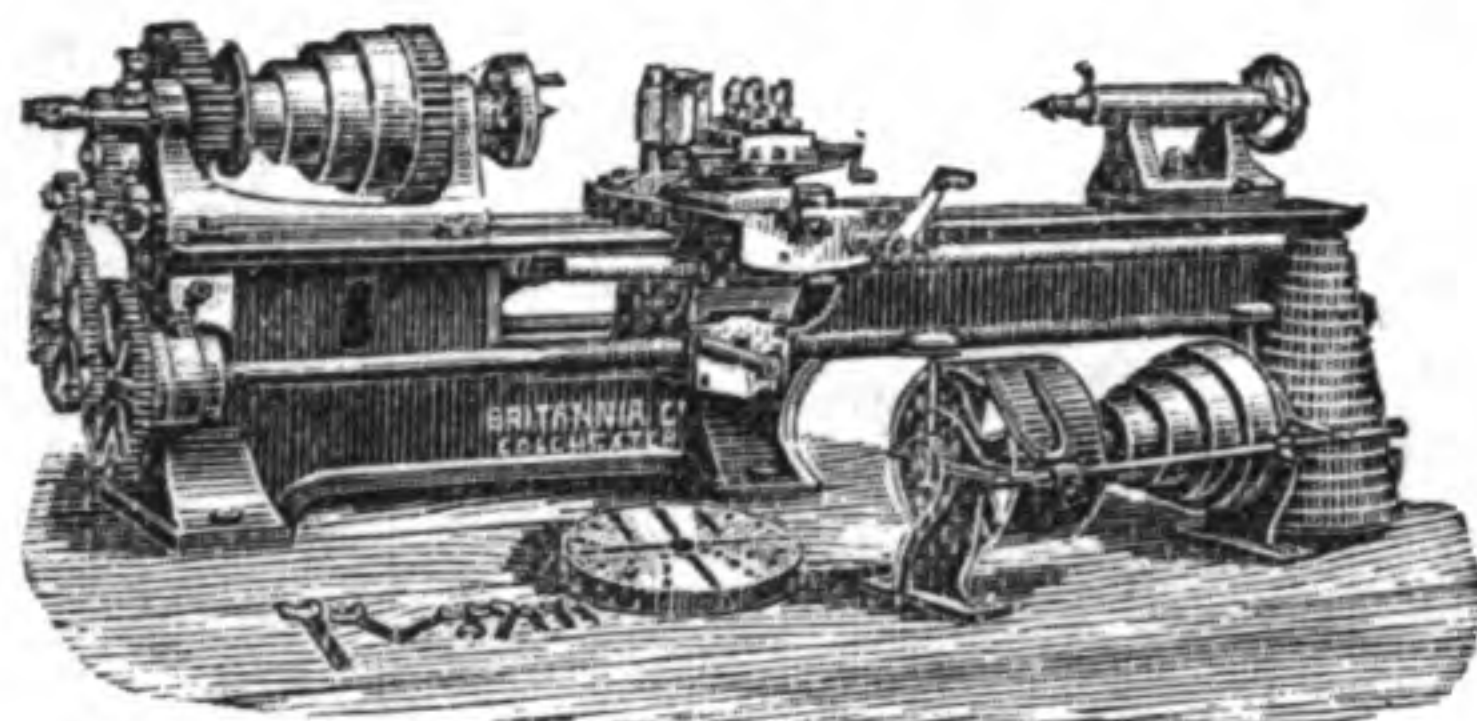

FITTED with double-gearred headstock, steel spindle, conical necks, gun-metal bearings, reversing motion for cutting right and left-hand screws; the loose headstock is fitted with cylinder mandrel, and left-hand square thread traverse screw, bright turned hand wheel, and can be made to set over by transverse slide motion for taper turning, if desired. The saddle has a flush top and T grooves for bolting work for boring purposes, compound slide rest, made to swivel to any angle for surfacing, and graduated for turning conical. The bed is accurately planed and surfaced, and provided with movable bridge piece for gap, box end at left hand, and firmly bolted to strong standard with planed faces at right-hand end. The metal is carefully distributed, so that the Lathe is quite rigid under the heaviest cutting strain; the leading screw is of steel, accurately cut, and extends full length of bed. It has a double clam gunmetal nut, actuated by eccentric movement to engage and release the saddle, the latter having also a quick hand traverse by rack, pinion, and double-purchase gearing.

The Lathe is fitted complete with back traversing stay, 22 change wheels, index plate, 24in. face plate, catchplate, and top driving apparatus complete, screws, keys, &c.

DIMENSIONS.

Bed, 19in. wide by 13in. deep; Gap, 19½in. wide by 11½in. deep, swinging 47in. diameter; Leading Screw, 2½in. diameter, ½in. pitch; Back Surfacing Shaft, 1½in. diameter; Extreme Length between Centres, 6ft. 8in.; Cone Pulley, four Speeds, 3½in. wide—largest speed, 16in., and smallest, 6½in. diameter; Gearing, 3½in. wide by 1½in. pitch—largest, 17½in.; Pinion, 6in. diameter; Steel Spindle, 2½in. body, 2½in. nose; Change Wheels (22), ½in. pitch. Approximate weight—4 tons.

	£	s.	d.
Price, Sliding and Screw Cutting			
„ Sliding, Surfacing, and Screw Cutting ..			
Poppet to Set over for Taper Turning, extra ..			
Extra Length of Bed, per foot			

We make a Lathe of similar design to the above, but of 14in. Centres, and with Beds to any length.

These Lathes are fitted for hard and accurate work, and are similar to those supplied to the British Government.

BRITANNIA WORKS, COLCHESTER, ENGLAND.

BRITANNIA CO.'S Improved Compound Slide Rest.

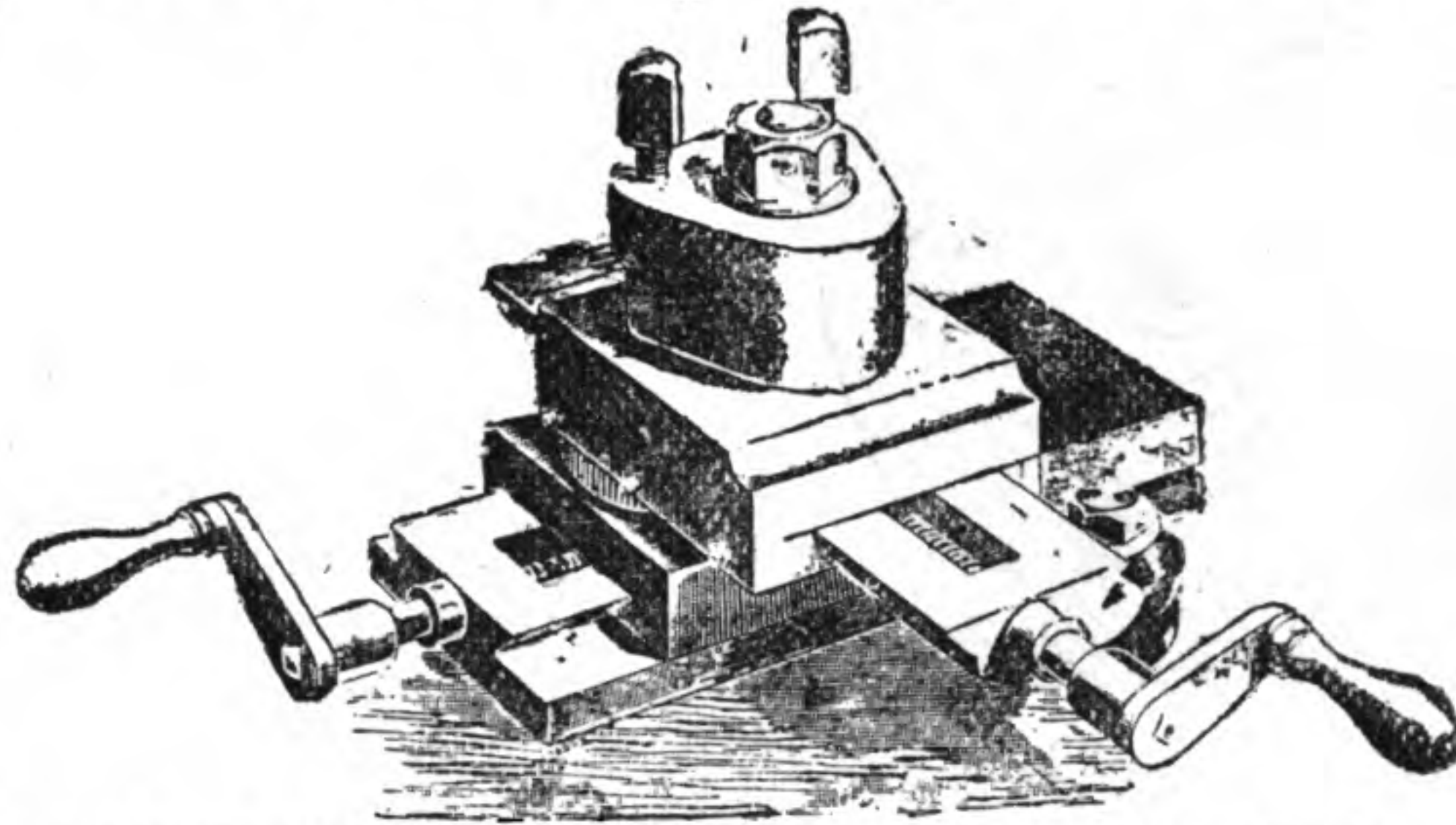

To suit 2½ in. centre Lathe ..	£2 0 0	To suit 5 in. centre Lathe ..	£5 0 0
„ 3 in. „ ..	2 10 0	„ 6 in. „ ..	6 0 0
„ 3½ in. „ ..	3 0 0	„ 7 in. „ ..	7 0 0
„ 4 in. „ ..	3 10 0	„ 8 in. „ ..	8 0 0
„ 4½ in. „ ..	4 0 0		

These are made so that the Bottom Slide always remains at a right angle with the Lathe Bed, the Rest having a swivel arrangement, accurately graduated, for turning taper or conical work to any desired angle.

The bottom cover, extending full length, excludes turnings and dirt from the screw and slide.

The materials are of the best. Screws are cast steel, gunmetal nuts, horn handles, improved tool box, with hardened steel screws.

The workmanship is excellent. The slides, &c., are surfaced up, and the parts, being machine made and uniform, are interchangeable.

Patent Double Driving Carriers.

Prices:

1 in. to 1½ in., 3/6

1½ in. to 2 in., 4/6

2½ in. to 2½ in., 5/6



Prices:

2½ in. to 3 in., 7/6

3½ in. to 3½ in., 9/6

3½ in. to 4 in., 11/6

Equalise the strain, and are generally more useful than ordinary carriers.

“ONCE TRIED ALWAYS USED.”

When the Lathe has not a Clement's driver, a stud in the face plate is required.

BRITANNIA WORKS, COLCHESTER, ENGLAND.

INDEPENDENT 4-JAW CHUCKS.

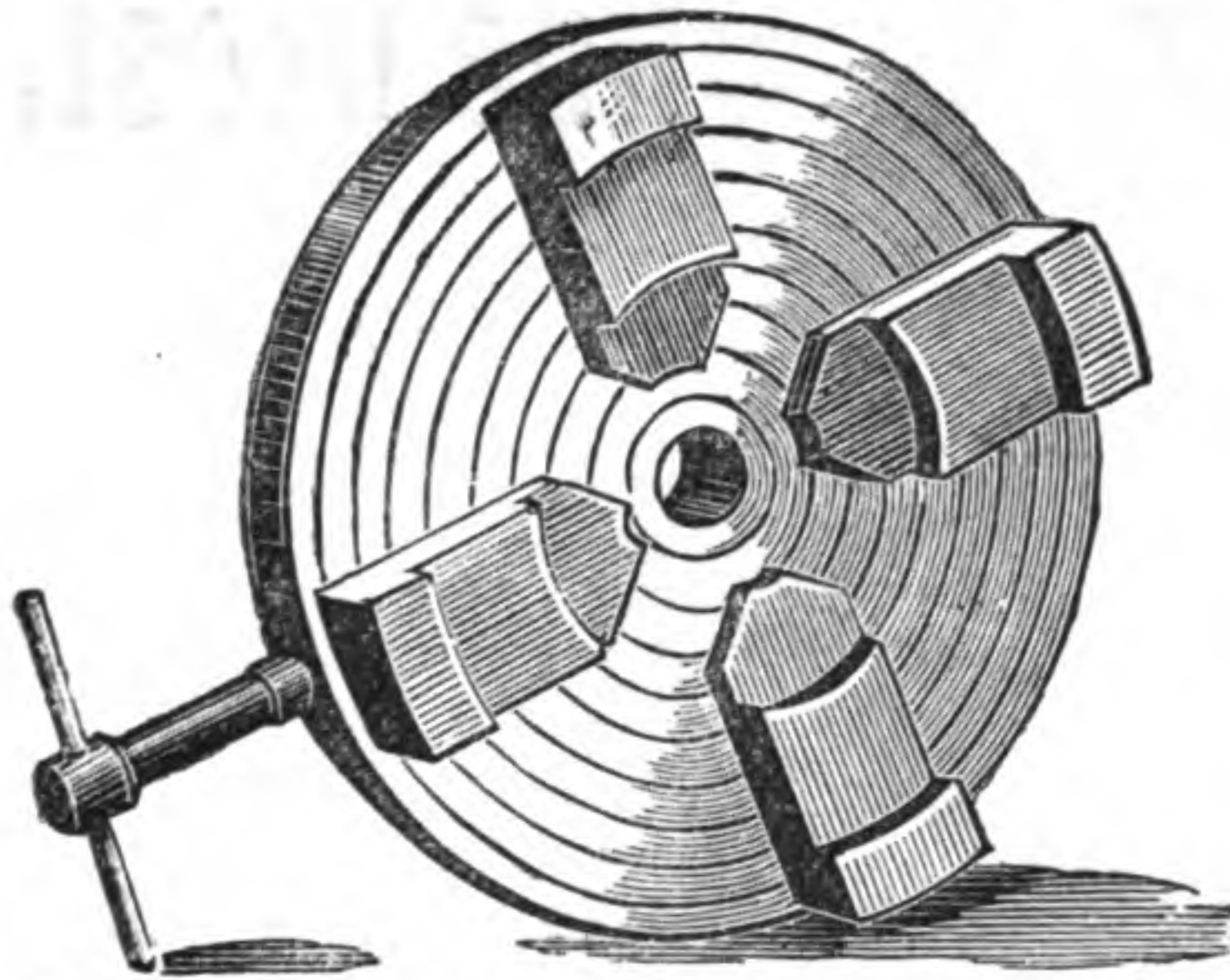

6 inch	60s.
8 "	80s.
9 "	90s.
10 "	100s.
12 "	120s.

Larger sizes, up to 20 inches diameter, per inch, 10s.

Above are extra strong, with wrought Jaws, and more durable than those generally sold.

THE JEWELLER'S CHUCK

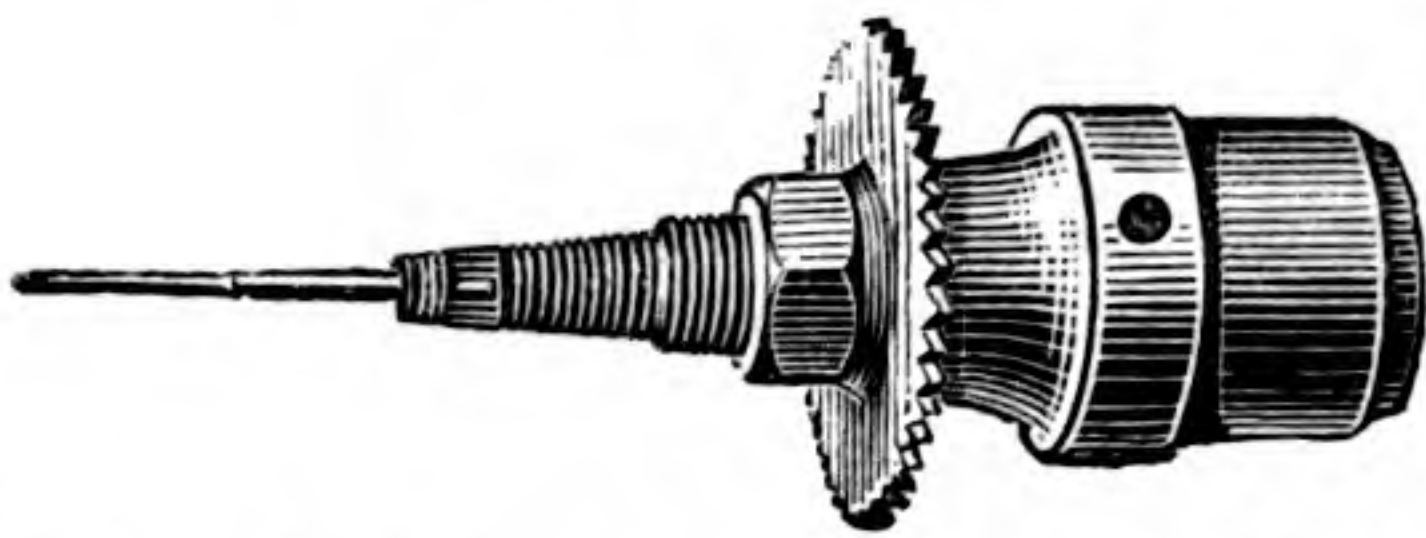

Is a valuable appliance to the mechanic or amateur. It carries drills, circular saws, and polishing brushes and polishing bobs.

Price 7s. 6d.; Saws to suit, 2s. 6d.; Polishing Brushes, 1s. 6d.; Emery Wheels, 2s. each.

WHITON'S "1883" DRILL CHUCK.

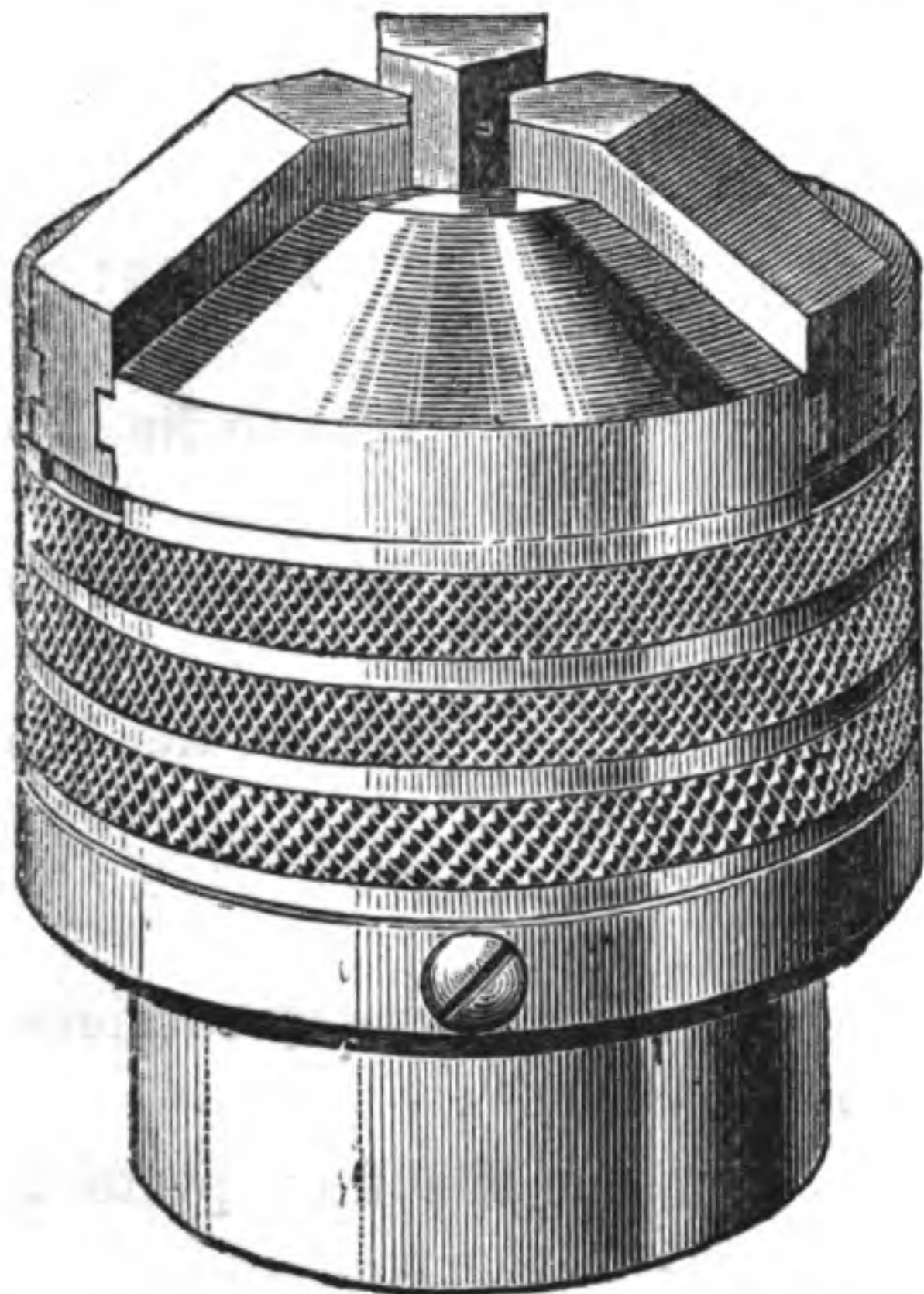

These Chucks are easily attached to any Lathe or Drill by a taper plug. All the parts are of steel, and thoroughly made.

No. 1, 2in. diameter, holds Drills from 0in. to $\frac{9}{16}$ in., 17s.

No. 2, 2½in. diameter, holds Drills from $\frac{1}{8}$ in. to $\frac{3}{4}$ in., 21s.

BRITANNIA WORKS, COLCHESTER, ENGLAND.

WHITON'S IMPROVED AMATEUR CHUCKS

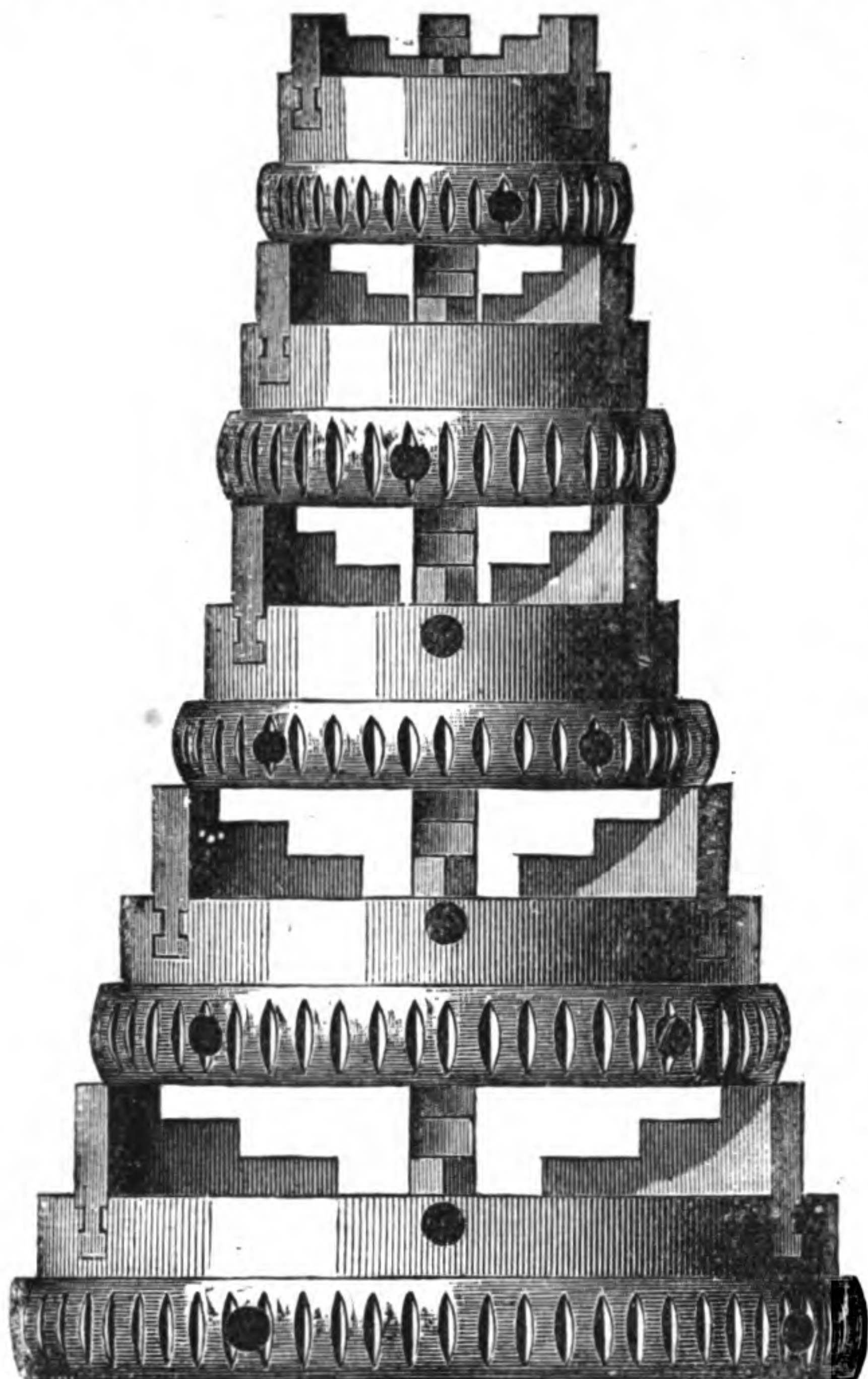

Are very neat in design, and are intended for amateurs' use on foot and light power lathes, and for all classes of light work.

Although very light, they are strong and durable, the shell being made of malleable iron, and the scroll and jaws of steel.

They are intended for attachment by means of a face plate.

They operate by hand or lever.

Diameter.	Weight about.	With Lathe Jaws (as shown in sketch).	With Lathe and Drill Jaws.
2 inches.	$\frac{3}{4}$ pounds.	19s.	24s.
2 $\frac{1}{2}$ "	1 $\frac{1}{4}$ "	21s.	26s.
3 "	1 $\frac{3}{4}$ "	23s.	28s.
4 "	3 $\frac{1}{2}$ "	27s.	34s.
5 "	5 "	32s.	38s.

Above Prices include Levers and Face Plate Screws.

When ordering chucks, it is necessary to send a chuck which exactly fits your mandrel. When chucks require fitting, an extra charge is made, usually about 10s. for face plate, &c.

Other American Scroll Chucks to order at usual lists.

BRITANNIA WORKS, COLCHESTER, ENGLAND.

ADVERTISEMENTS.

WHITON'S PATENT GEARED SCROLL CHUCK.

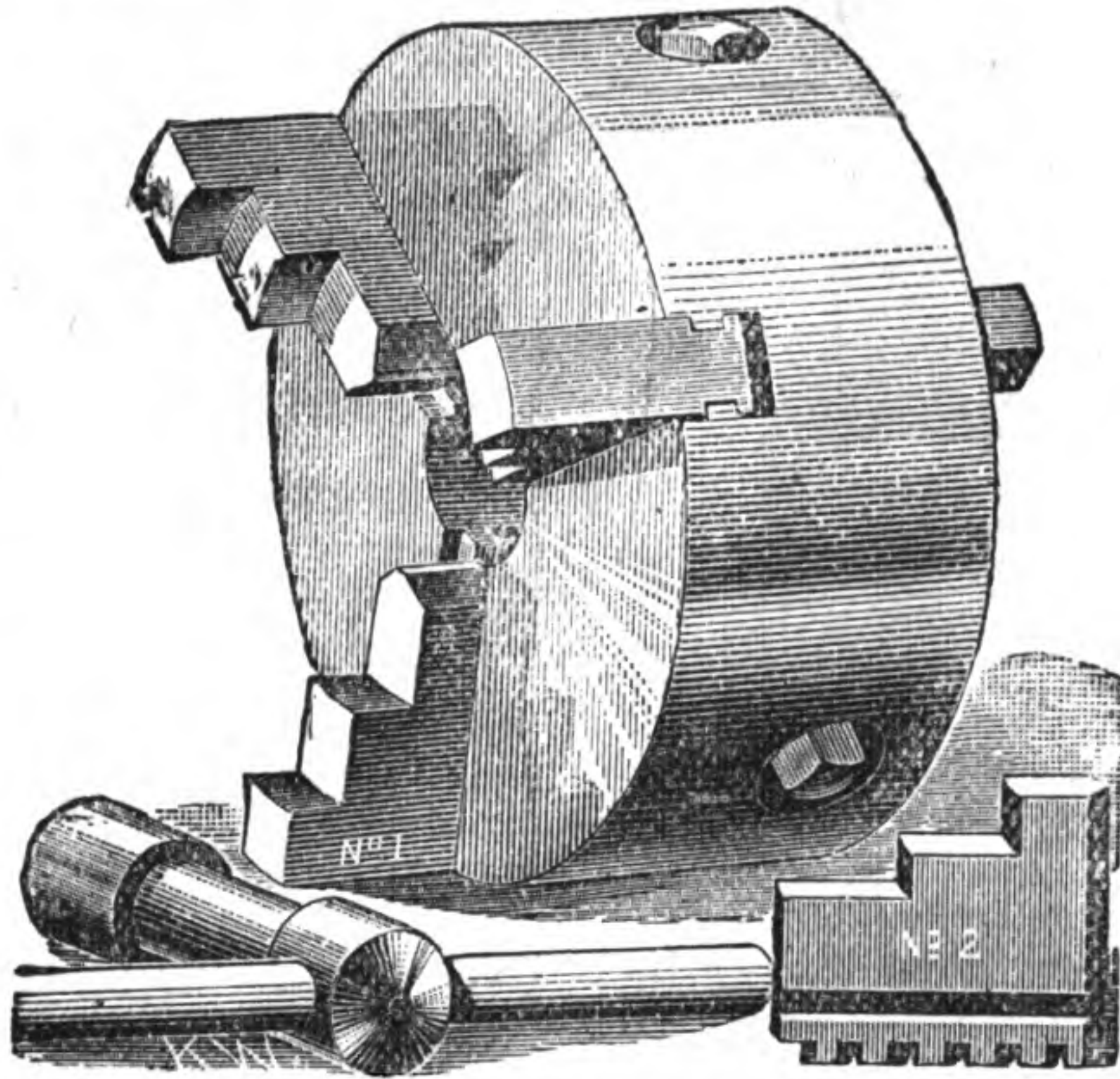
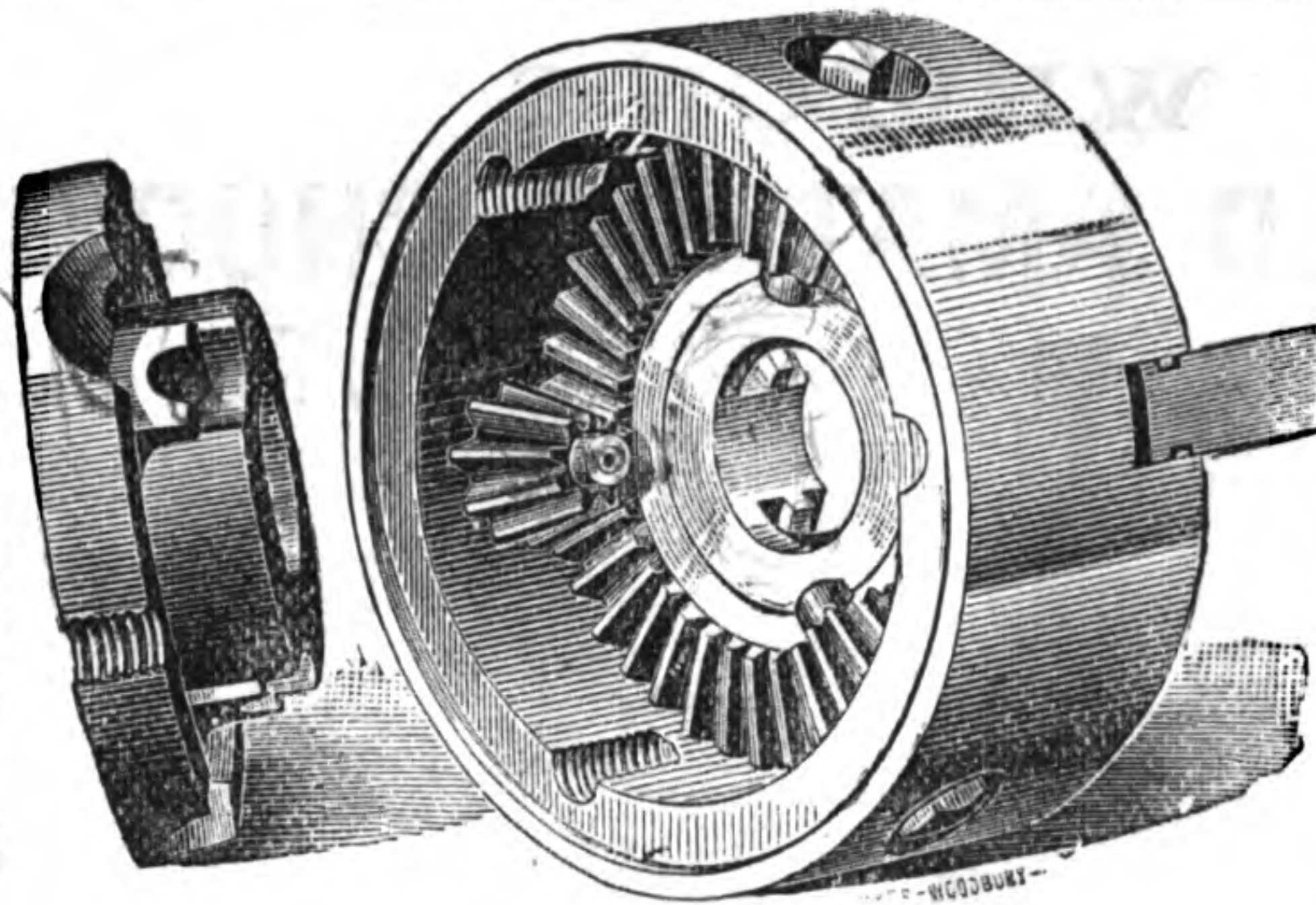

DIAMETER.	WEIGHT ABOUT.	PRICE.	DIAMETER.	WEIGHT ABOUT.	PRICE.
2½ inches.	2 pounds.	30s.	6 inches.	12½ pounds.	71s.
3¼ "	3 "	42s.	7½ "	20 "	80s.
4½ "	6 "	50s.	9 "	35 "	92s.
5 "	8½ "	59s.	12 "	60 "	125s.

The outer shells of all chucks up to and including 5in. are of malleable iron, and the jaws, scrolls, pinions, &c., of all sizes are of steel. The workmanship is first-class throughout. Price List includes keys and bolts. Unless otherwise ordered, these chucks are always supplied with lathe jaws. Add 10 per cent. for chucks having four jaws. Add 20 per cent. for chucks having two sets of jaws (lathe and drill).

WHITON'S IMPROVED LEVER CHUCKS.

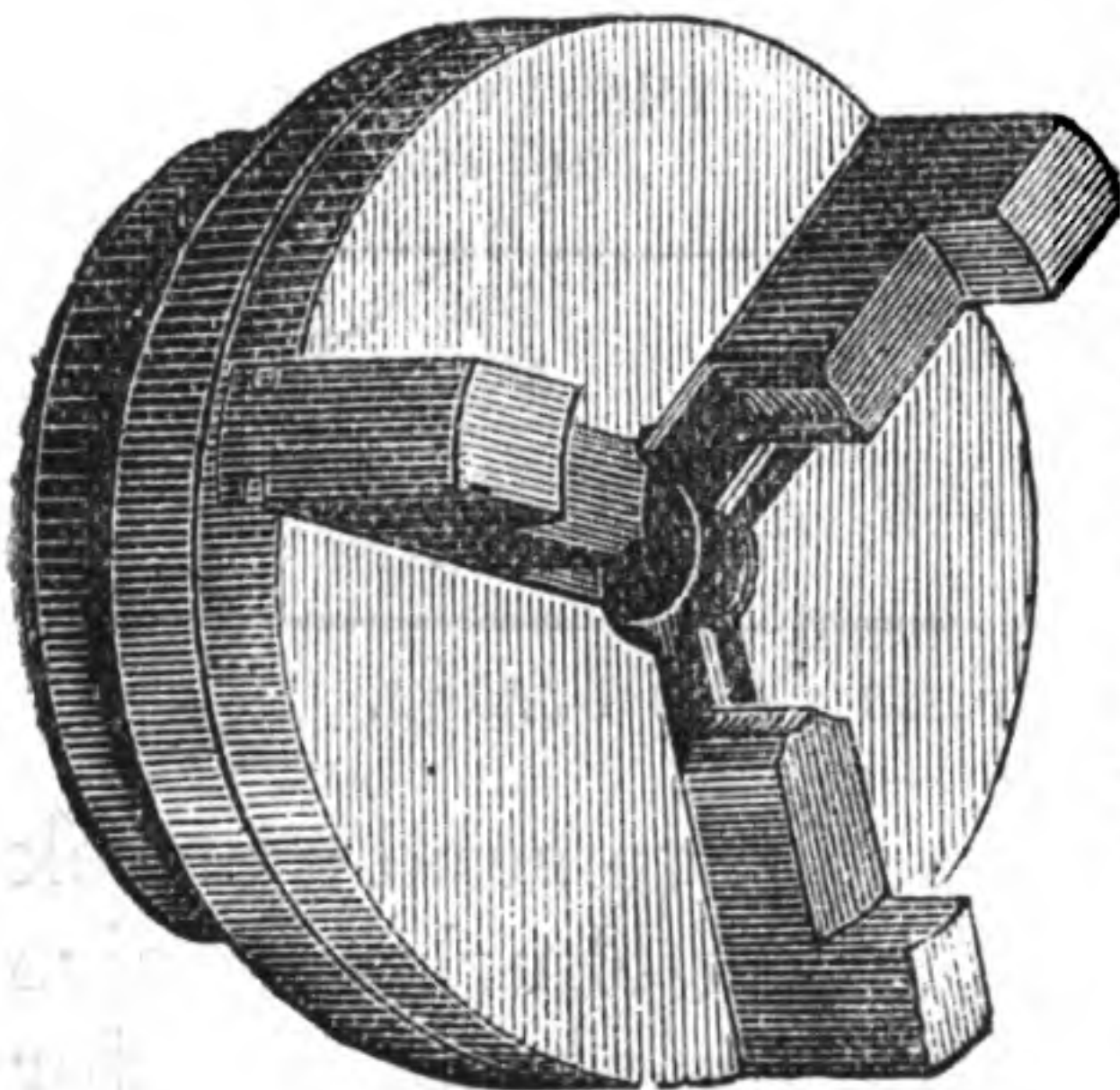

A heavy band of wrought iron is shrunk firmly around the front plates of the larger sizes, which are thus greatly strengthened. The holes in the scroll for receiving the lever are drilled into bosses cast for the purpose, while the outer rim of the scroll between these bosses is much lighter than formerly; thus the parts of this chuck receiving the heaviest strains are made stronger than in other chucks of this class, without making them inconvenient from over weight.

The front plates of the 3in., 4in. and 6in. sizes are of malleable iron, and the scrolls and jaws of steel.

DIAMETER.	PRICE.	DIAMETER.	PRICE.
3 inches.	34s.	15 inches.	134s.
4 "	42s.	18 "	159s.
6 "	67s.	21 "	200s.
9 "	88s.	24 "	250s.
12 "	109s.		

Unless otherwise ordered, these chucks are always supplied with lathe jaws. Add 10 per cent. to above list for chucks with four jaws. Add 20 per cent. to above list for chucks with two sets of jaws (lathe and drill).

BRITANNIA WORKS, COLCHESTER, ENGLAND.

ADVERTISEMENTS.



THE ESSEX CHUCK.

To take up to $\frac{1}{4}$ in. Drills 10s.
 Size larger, to take $\frac{1}{2}$ in. Drills 25s.

Made of Steel throughout.

A CHEAP AND DURABLE CHUCK.

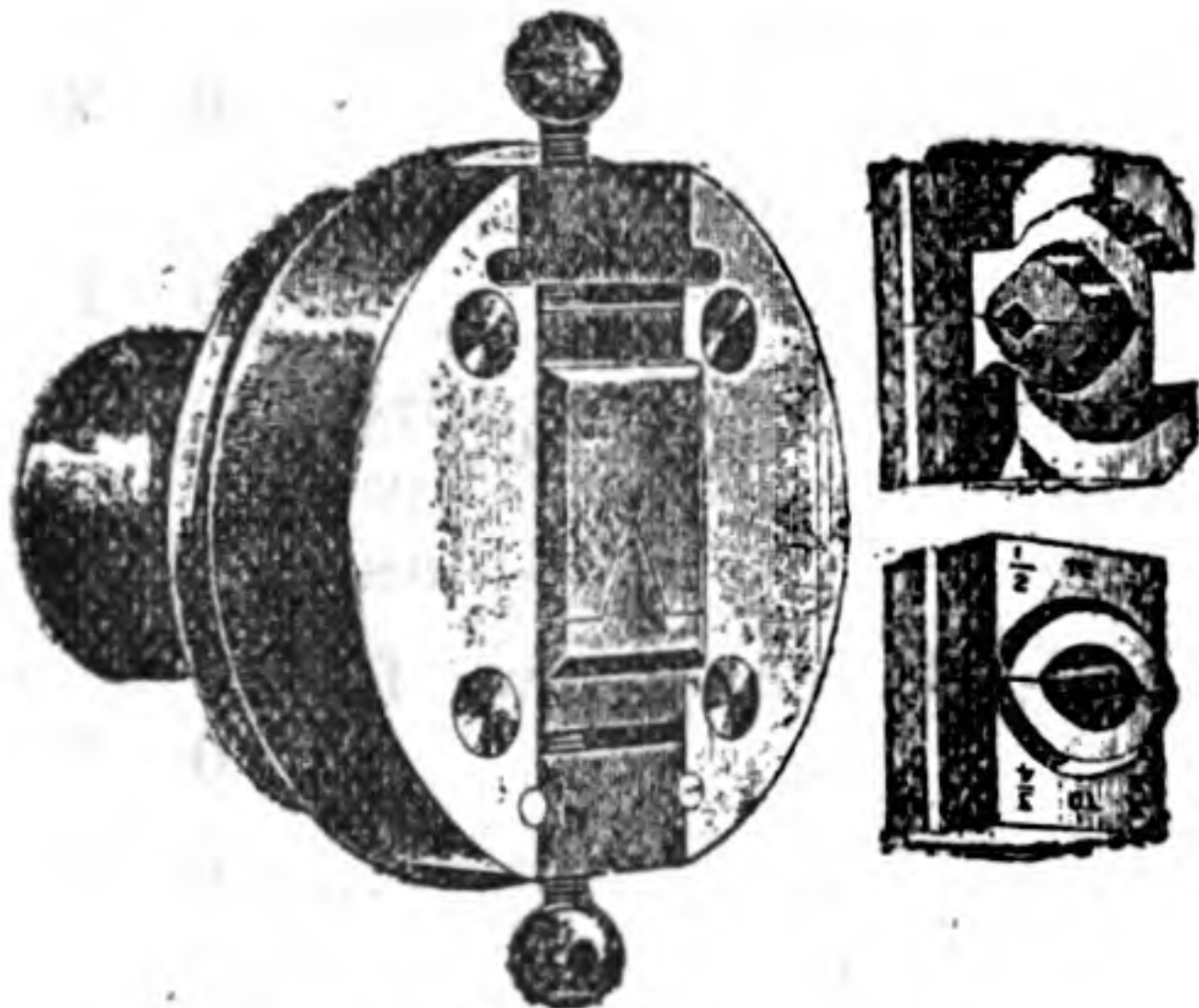

J. K. P. CHUCK.

50s.

Extra jaws, 10s.

Holds Tighter.

Wears Longer.

**Holds Irregular Forms
as well as Regular.**

Can be set Eccentric.

With the Jaws as Fixed it Holds Drills $\frac{5}{64}$ to $\frac{27}{64}$.

Holds Articles $\frac{11}{16}$ to $1\frac{11}{16}$ with No. 1B Die.

Die 1A is made to hold to $\frac{1}{2}$, $\frac{1}{2}$ to $\frac{3}{4}$, $\frac{3}{4}$ to 1-inch.

Special Jaws made to Suit Special Jobs.

BRITANNIA Co. have much pleasure in recommending the above Chuck. It offers many advantages which will be obvious to experienced Mechanics.

PRICE £2 10s. with one set of Jaws; 10s. per pair for extra Jaws of either pattern.

BRITANNIA WORKS, COLCHESTER, ENGLAND.

USEFUL LATHE CHUCKS, &c.



No.		£	s.	d.
1	Pronged Chuck, for wood, $\frac{5}{8}$ in. shank	0	2	6
2	Cross or Four-blade Chuck, for hard wood, $\frac{5}{8}$ in. shank ...	0	3	0
3	Square Tapered-hole Chuck, to suit ordinary brace bits, $\frac{5}{8}$ in. shank	0	3	0
4	Solid Gunmetal Chuck, $\frac{5}{8}$ in. shank, face left solid and plain to turn to requirements	0	1	6
5 & 6	Main Chuck, turned and tapped to fit nose of mandrel, and with $\frac{5}{8}$ in. hole at other end to receive the "Essex" or other small chucks	0	7	6
7	Flange Chuck, 2in. diameter, with taper screw for wood	0	6	0
	Ditto, 4in. diameter	0	7	6

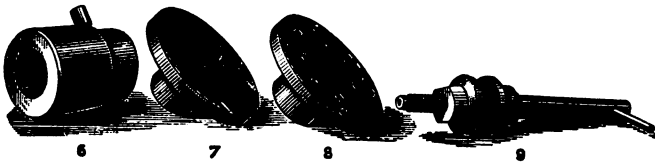

8	Flange Chuck for attaching flat wood to, bored and tapped to fit mandrel nose, and drilled, countersunk at back, 3in. diameter	0	5	0
	Ditto, 6in. diameter	0	7	6
	Gunmetal Cup Chucks, of various diameters $\frac{3}{4}$ in., 2/6; 1in. 3/-; 1 $\frac{1}{4}$ in., 4/-; 1 $\frac{1}{2}$ in., 5/-; 2in., 6/6; 2 $\frac{1}{2}$ in., 8/-; and 3in., 10/- each The set	1	19	0
	Drill Chuck, $\frac{3}{8}$ in. hole, with set screw and extra plug for small drills, $\frac{5}{8}$ in. shank	0	4	6
	Self-centring Chuck for wood, with conical hole, ribbed longitudinally	0	7	6

BRITANNIA WORKS, COLCHESTER, ENGLAND.

USEFUL LATHE APPLIANCES.

BELL * CHUCKS.

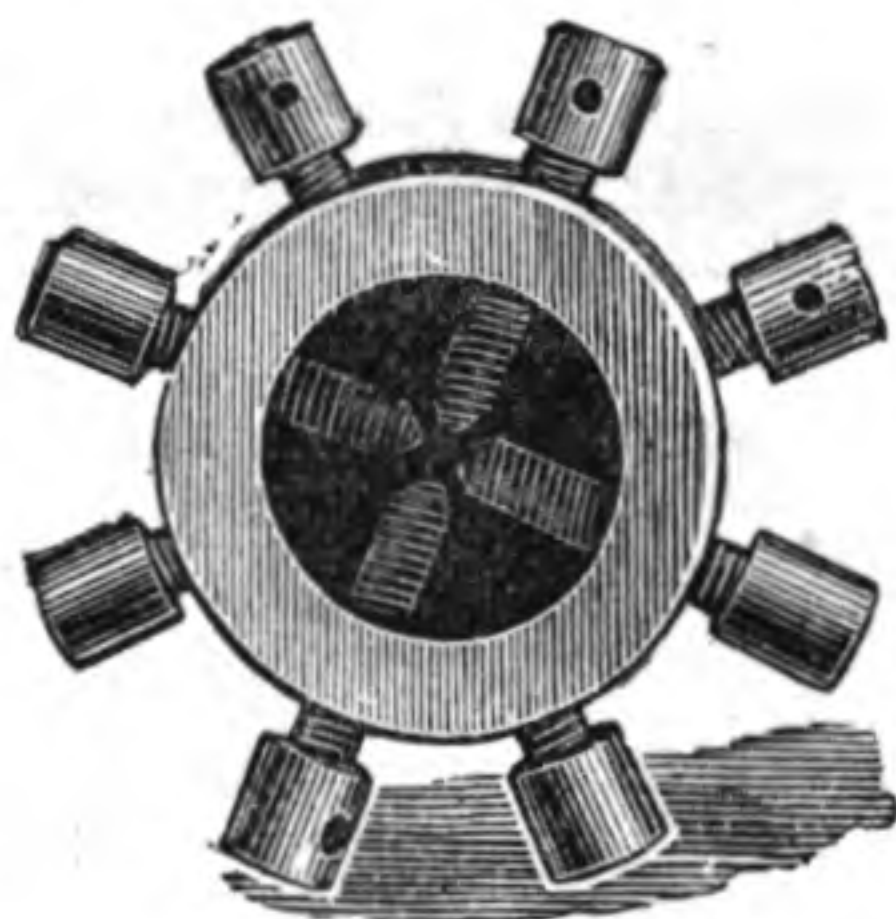

Outside diameter.	Inches—	2	3	4	5	6	7	7½	10
Four Screws	14/-	15/-	17/6	22/6	25/-	32/6	38/-	50/-
Eight Screws	14/-	18/-	22/-	25/-	30/-	38/-	45/-	60/-

Oval, Eccentric, and Ornamental Chucks made to order.
Ornamental Rests, Drill Spindles, Cutters, &c.

Lathe Carriers, Steel Screws, turned shanks, ⅜in. 1/4; ½in. 1/8; ¾in. 2/-; 1in. 2/6;
1¼in. 3/-; 1½in. 3/6; 1¾in. 4/6; 2in. 5/-

Turning Tools for Wood or Metal, for Hand, 1/-, 1/6, and 2/- each. Ditto for Slide
Rests, ⅜in. 1/-; ½in. 1/3; ¾in. 1/6; 1in. 1/9.

Screw Chasing Tools, internal and external, price per pair, Handled, from 40 to 12
threads per inch, 3/-; from 11 to 6 threads per inch, 4/-

Taps, Taper or Plug,

Size	¼	⅕	⅜	⅜	½	⅝	¾	⅞	1	1½	1¼	inch.
Price	2/-	2/-	2/-	2/6	2/6	3/-	4/-	5/-	7/-	8/-	9/-	each.
Boring Bars			2/6	3/-	3/-	4/-	5/-	each.				Cutters, 6d. each.
Swivel Cutter Bars			7/6	8/6	8/6	9/6	11/-	„		„	„	

Plain Drills, 2d., 3d., 4d., and 6d. each. Milling Wheels, with Handles, 2/- each.

Circular Saws, 4in. 4/-; 5in. 5/6; 6in. 7/-; 7in. 8/-; 8in. 9/6 each.
Platforms for ditto, 6 by 8, 12/6; 8 by 12, 15/-

Mandrel with Screw Collars for Holding Saws or Emery Wheels, 6/- and 8/- each.

Grindstones, with Troughs, for fixing on above Mandrels,
4in. 3/6; 5in. 4/-; 6in. 5/-

BRITANNIA WORKS, COLCHESTER, ENGLAND.

BALCK'S PATENT GIRDER * LATHE * PLANER.

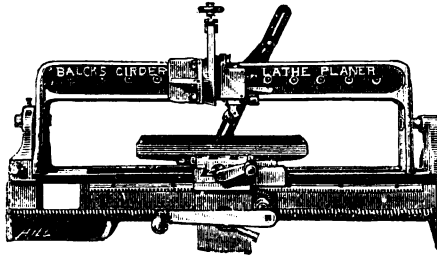

The above Engraving illustrates a very handy Planer.

IT is made to work upon the bed of a Lathe, and it is secured in its place between the centres. A rack and pinion screwed under the top of lathe bed, and a crank handle, gives the movement backward and forward. The saddle of a screw-cutting Lathe may in some cases be utilised.

It has a self-acting feed motion, and some are fitted with two tool boxes, so as to cut each way. Britannia Company fit Lathes to suit this Planer without extra cost, but ordinary Lathes require stronger racks, and extra is charged for fitting.

This tool had a very favourable notice in the *English Mechanic*, May 7th, 1886.

PRICE FROM £9.

~~~~~  
**A similar Planer, but fitted with an independent bed, which can be worked on any Bench or Table, price £10, is a most valuable addition to the workshop of the Mechanic.**

~~~~~  
SOLE MAKERS:—

Britannia Company, Colchester.

ON VIEW AT THEIR SHOW-ROOMS,

100, * HOUNDSDITCH, * LONDON.

BRITANNIA WORKS, COLCHESTER, ENGLAND.

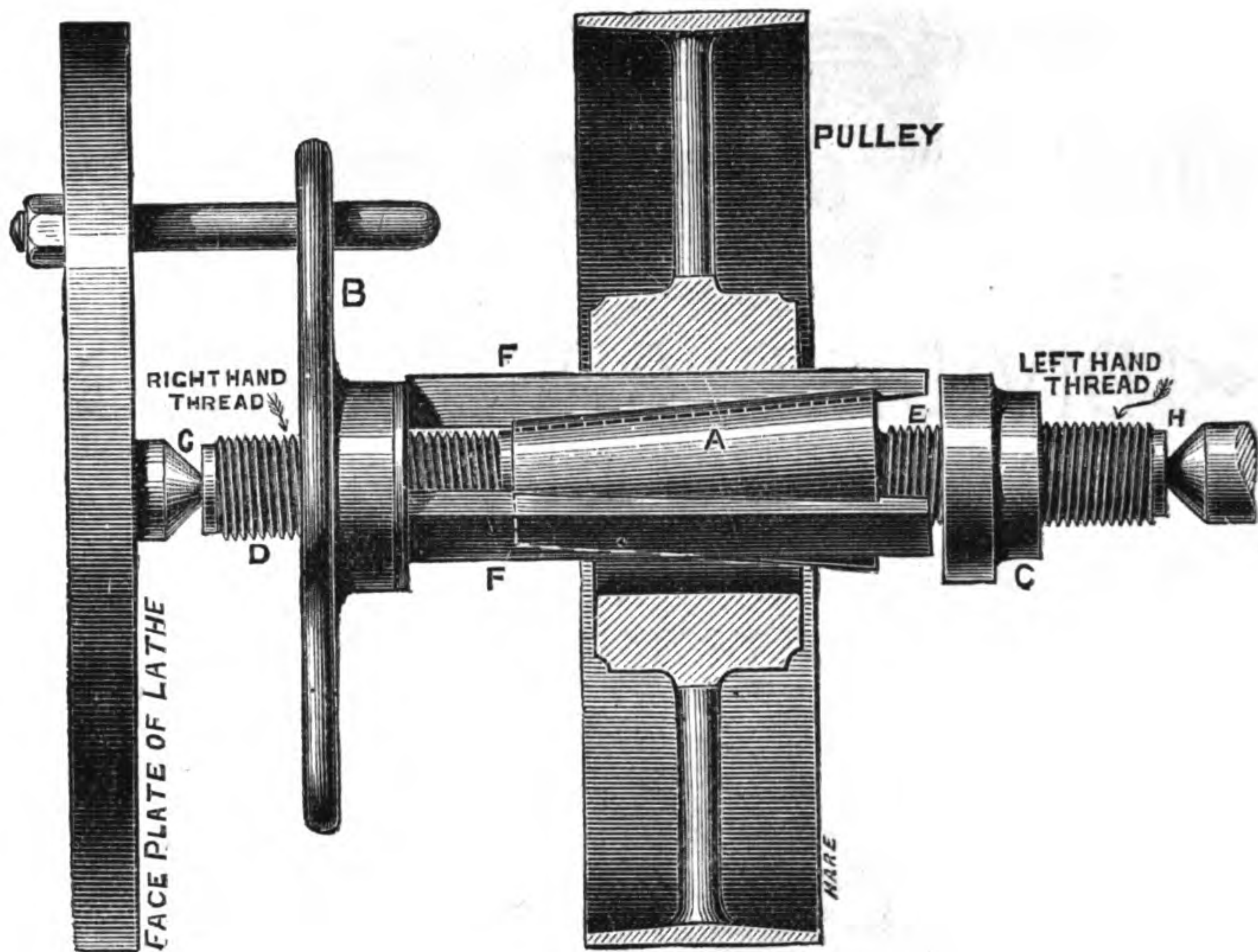

PATENT

Expanding Lathe Mandrel.

Made in various Sizes, from $1\frac{1}{4}$ in. to $2\frac{5}{8}$ in.

Supplied to the Royal Arsenal and all
the principal Railway Works, &c.

Sole Makers—Britannia Co., Colchester.

GEAR CUTTERS, STOCKS AND DIES, TWIST DRILLS,
PORTABLE FORGES, ANVILS, VICES (FOR IRON
OR WOOD), MORTICING MACHINES, BAND SAWS.

Above are supplied, of reliable quality, at Moderate Prices.

BRITANNIA WORKS, COLCHESTER, ENGLAND.

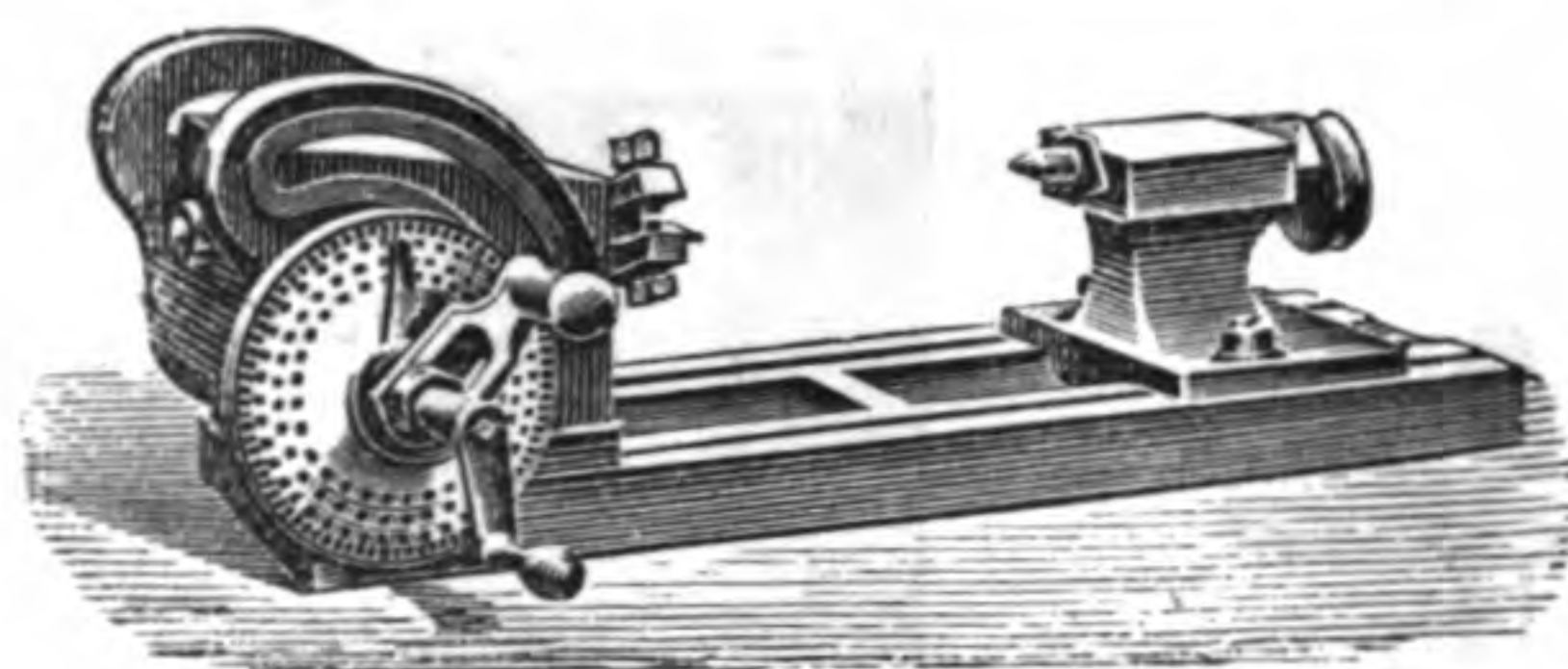

∞ DIVIDING APPLIANCE, ∞

FOR MILLING AND SHAPING,

✦ AS SUPPLIED TO THE ROYAL ARSENAL. ✦

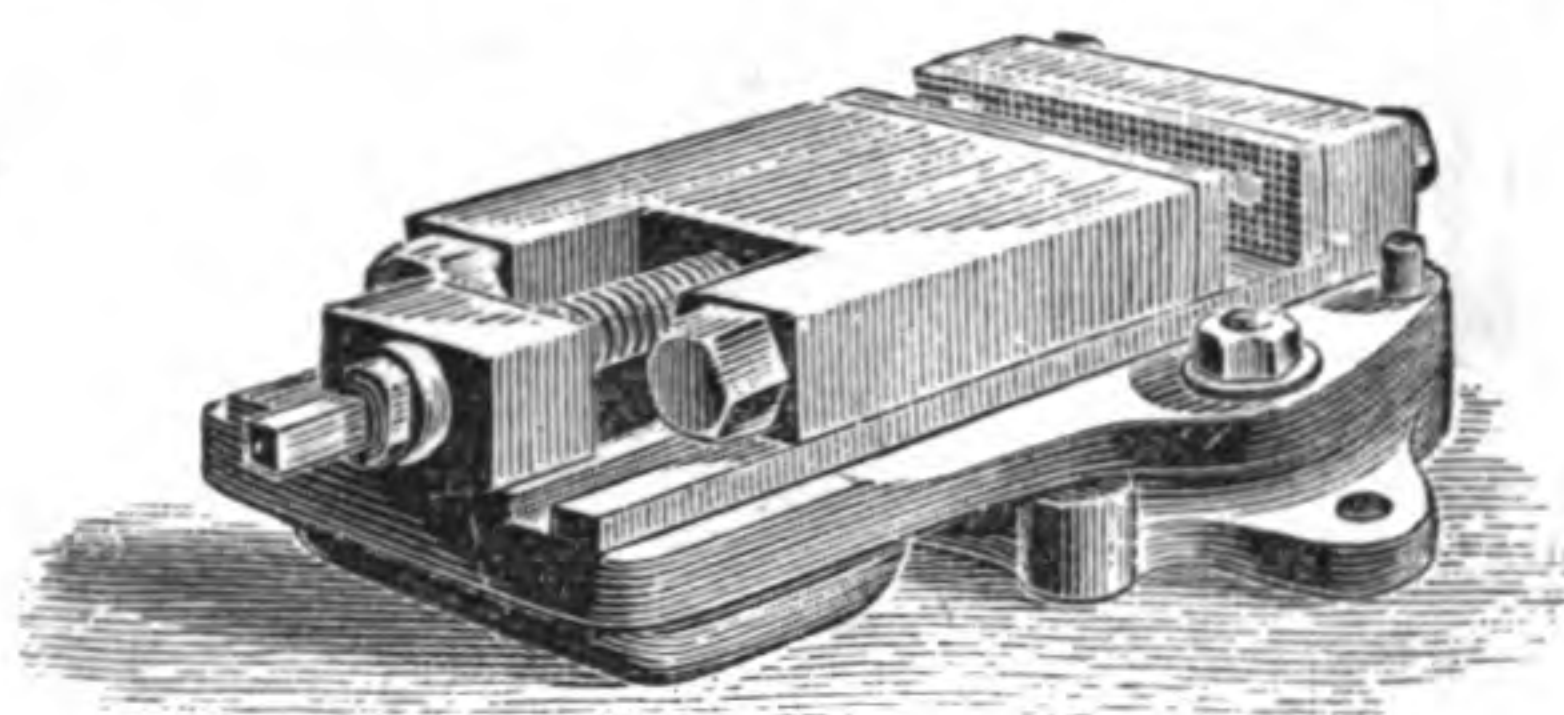

ENGINEER'S VICE

(STRONG PATTERN, WITH SWIVEL BOTTOM),

FOR MILLING AND PLANING.

Price £5 10s.

DRILLING MACHINES IN GREAT VARIETY,
From 50s. upwards.

PLANING MACHINES, SHAPING MACHINES, SLOTTING MACHINES.

MILLING MACHINES (3 Patterns):

Our largest will mill six surfaces 4ft. at one operation.

 **TOOLS DESIGNED, OR MADE TO DRAWING,**
For Special Work.

Apply at BRITANNIA TOOL FACTORY, COLCHESTER.

BRITANNIA COMPANY'S Registered Screw-Cutting Guide.

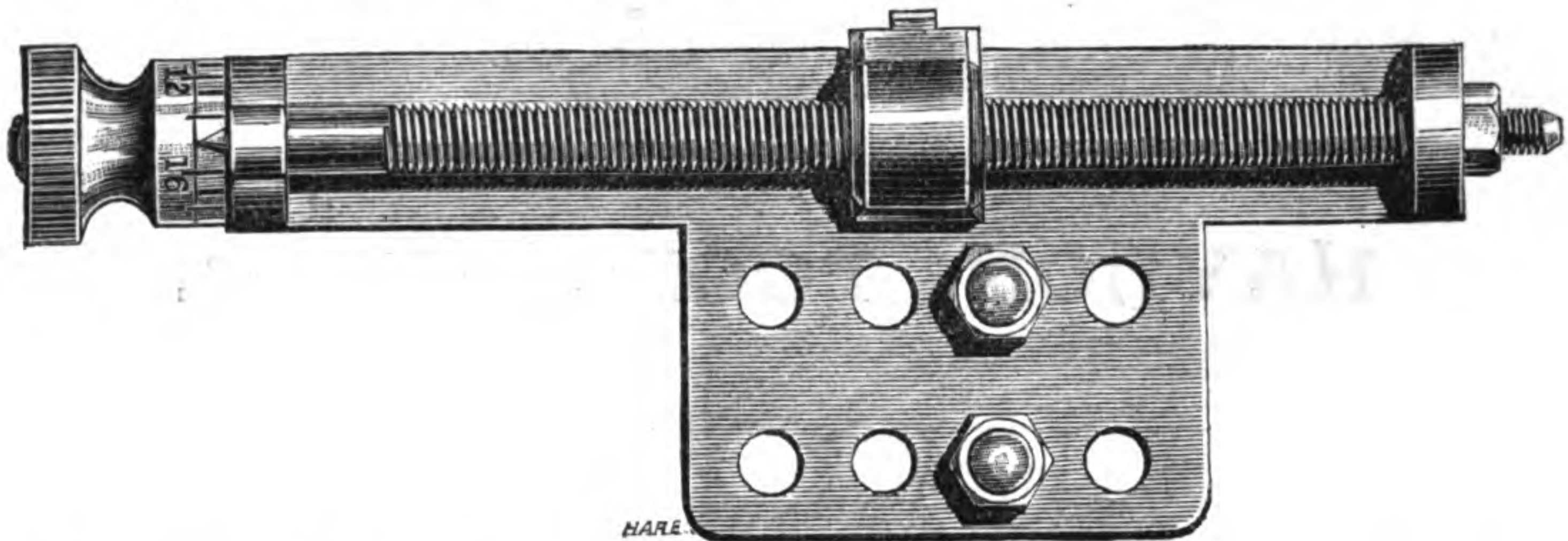

THE above appliance can be used on any Lathe. By its use the workman can regulate the depth of cut to the greatest nicety, and the use of the chalk mark, or any such expedient, is unnecessary.

It can be used for inside or outside screw cutting, or other work requiring uniformity. It saves time from insufficiency of cut. It prevents the breaking of tools, or the work being torn out from the centres. It is a reliable stop for ornamental drilling and fluting.

While the Lathe is cutting this can be adjusted for the following cut. It only requires to be bolted upon the saddle of a Screw-cutting Lathe, and a projecting stud or screw fixed in the middle slide engages the stop.

It can also be used on ordinary Lathes with slide rest—in this case it must be fixed to the bed.

This is a tool which has long been wanted by engineers, and will also be appreciated by amateurs.

PRICES.

For 3in. to 4in. Centre Lathes	25s.
5in. and 6in. „	30s.
8in. to 10in. „	35s.

Sole Makers:—BRITANNIA COMPANY,
100, HOUNDSDITCH, LONDON.

All Letters to Britannia Works, Colchester.

BRITANNIA WORKS, COLCHESTER, ENGLAND.

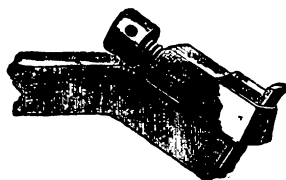

HAYDON TOOL-HOLDER.

ADVANTAGES :

Users of these Holders save the cost and inconvenience of forging their tools.

The Cutters are easily sharpened to the correct angle.

By due attention to the instructions superior finish can be given to the work.

A stock of the small Cutters can be always kept sharpened, as they cost but little, and occupy a small space.

The steel of which the Cutters are made can be bought in 12in. or 14in. lengths, and cut off as required, or Cutters can be purchased at 6d. each.

Plain directions for sharpening Cutters to the **exact angle** required for various metals, and how to use the tools to best advantage, will be sent with each Bar. A diagram showing the various angles will prevent the possibility of errors in judgment.

	s. d.
$\frac{3}{4}$ in. Bars, will suit Lathes 3in. and 3 $\frac{1}{2}$ in. centre ...	Price 9 6
$\frac{1}{2}$ in. " " 4in., 4 $\frac{1}{2}$ in., and 5in. ...	" 10 0
$\frac{1}{4}$ in. " " 5in. or 6in. ...	" 10 0
$\frac{3}{4}$ in. " " 6in. and 7in. Lathes ...	" 12 6
$\frac{1}{2}$ in. " " 7in. to 9in. ...	" 15 0
lin., for larger sizes ...	" 17 6

BRITANNIA WORKS, COLCHESTER, ENGLAND.

ADVERTISEMENTS.

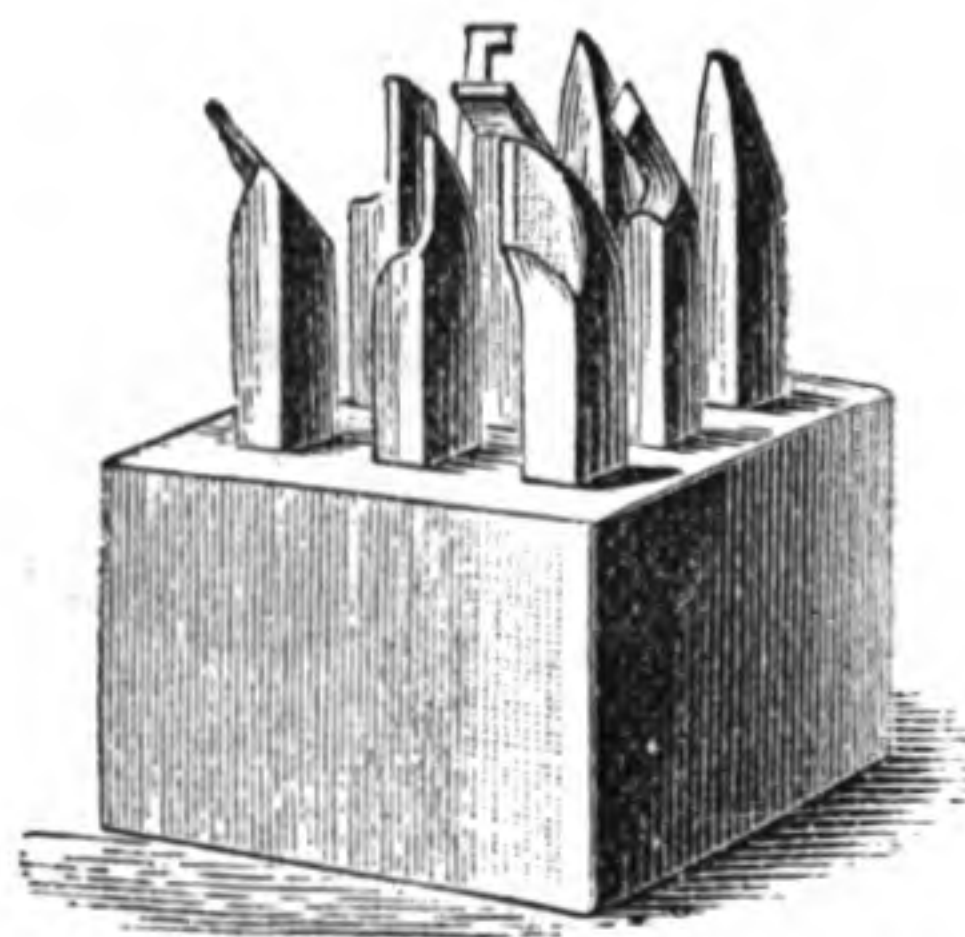
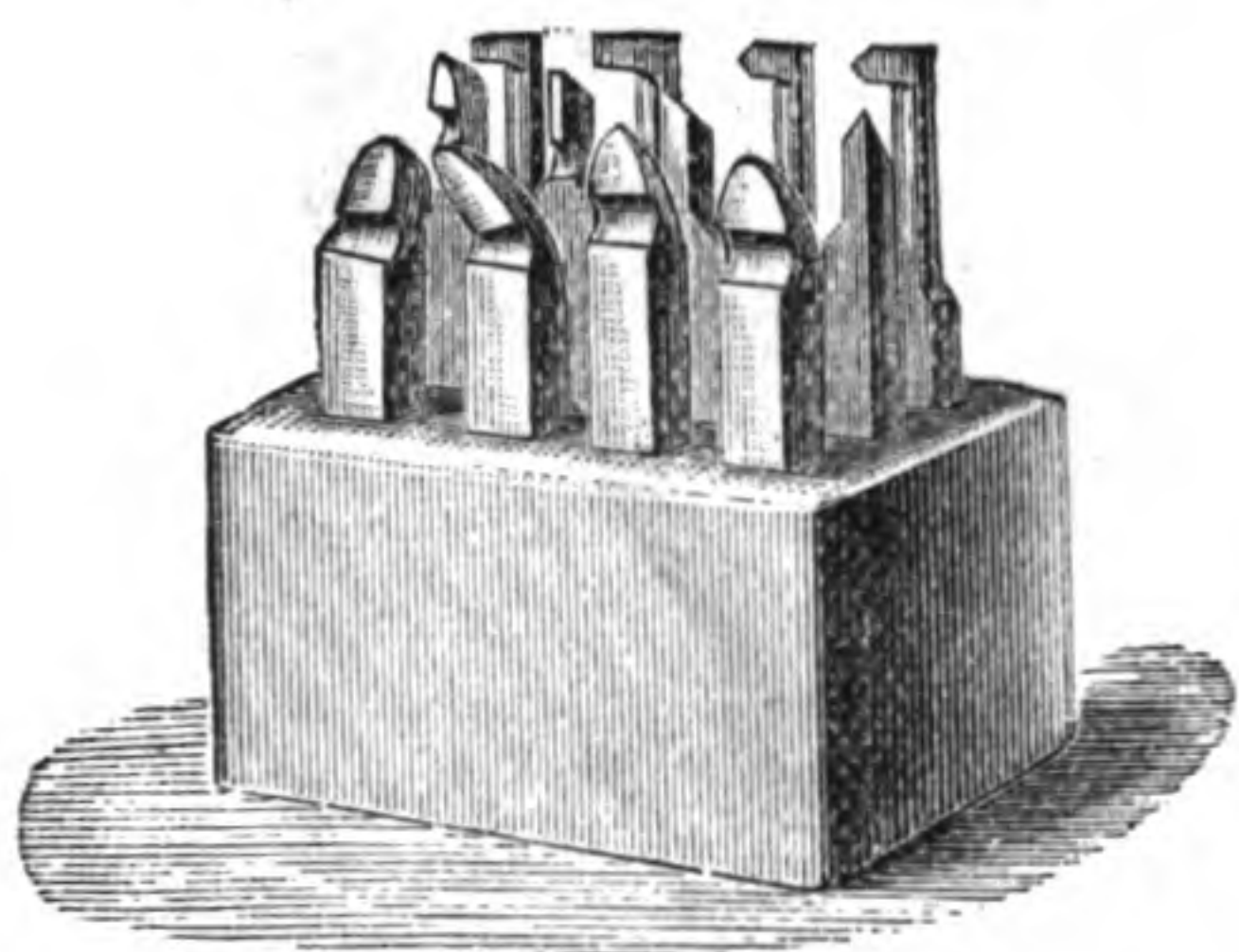

SLIDE REST TOOLS

In great variety, made of the very best steel.

The Patterns most generally used are: No. 1; No. 19.
Sold Singly, or in Sets.

	$\frac{3}{8}$	$\frac{1}{2}$	$\frac{5}{8}$	$\frac{3}{4}$	inch.	
	1/-	1/3	1/6	1/9	each.	
No. 20. {		$\frac{3}{8}$	$\frac{1}{2}$	$\frac{5}{8}$	$\frac{3}{4}$	inch.
		7/6	8/6	9/6	10/6	each.
No. 21. {	$\frac{3}{8}$	$\frac{7}{16}$	$\frac{1}{2}$	$\frac{5}{8}$	$\frac{3}{4}$	inch
No. 22. {	2/6	3/-	3/-	4/-	5/-	each

BRITANNIA WORKS, COLCHESTER, ENGLAND.

LATHE TOOLS.

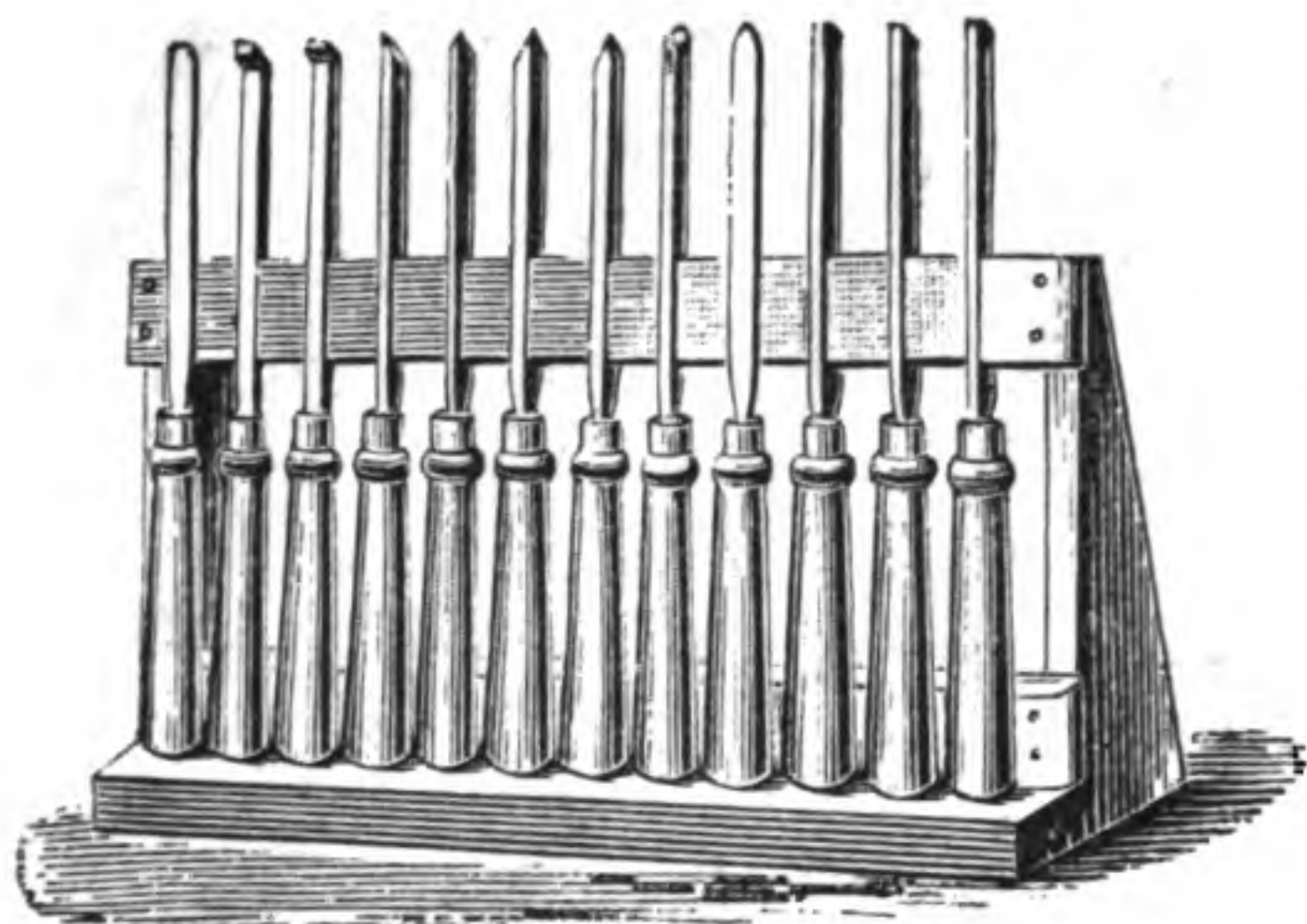

Hand Turning Tools in great variety, 1s. each, 10s. per doz.

Larger sizes, 1s. 3d., 1s. 6d., and 2s. each.

Long Handles if specially ordered.

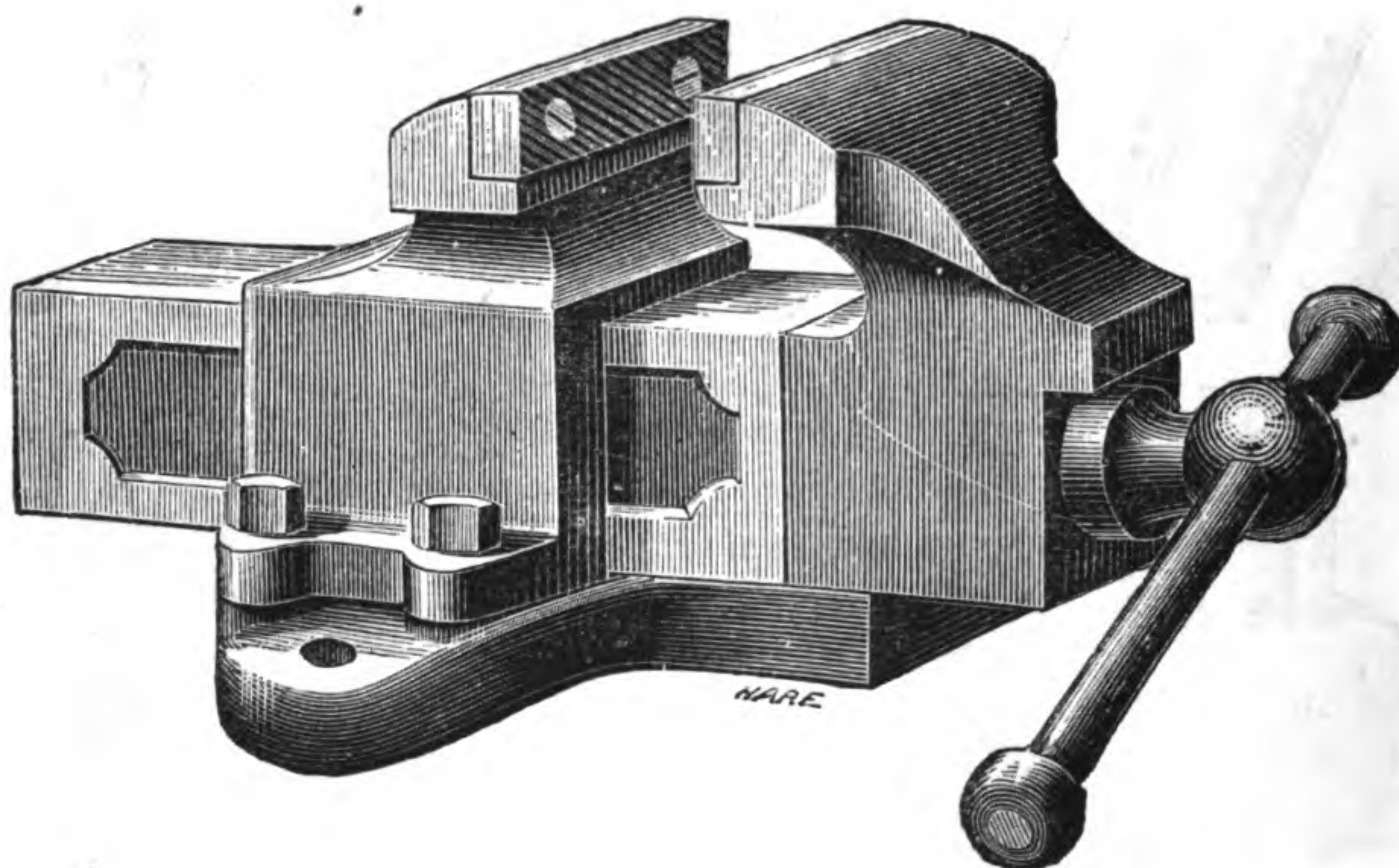

PARALLEL BENCH VICES,

WITH STEEL JAWS.

MADE IN THREE SIZES.

	No. 1.	No. 2.	No. 3.
Measure across jaw ...	2 $\frac{3}{4}$ in. ...	3 $\frac{1}{4}$ in. ...	3 $\frac{3}{4}$ in.
Will open	3 $\frac{1}{2}$ in. ...	4in. ...	5in.
Weight	11lb. ...	18lb. ...	29lb.
Price	10/6 ...	17/6 ...	25/-

BRITANNIA WORKS, COLCHESTER, ENGLAND.

BRITANNIA COMPANY'S
CHEAP GAS ENGINE.

Simple!
Efficient!
Making Little
Noise!
Economical!
About 3d. per day
for Gas!

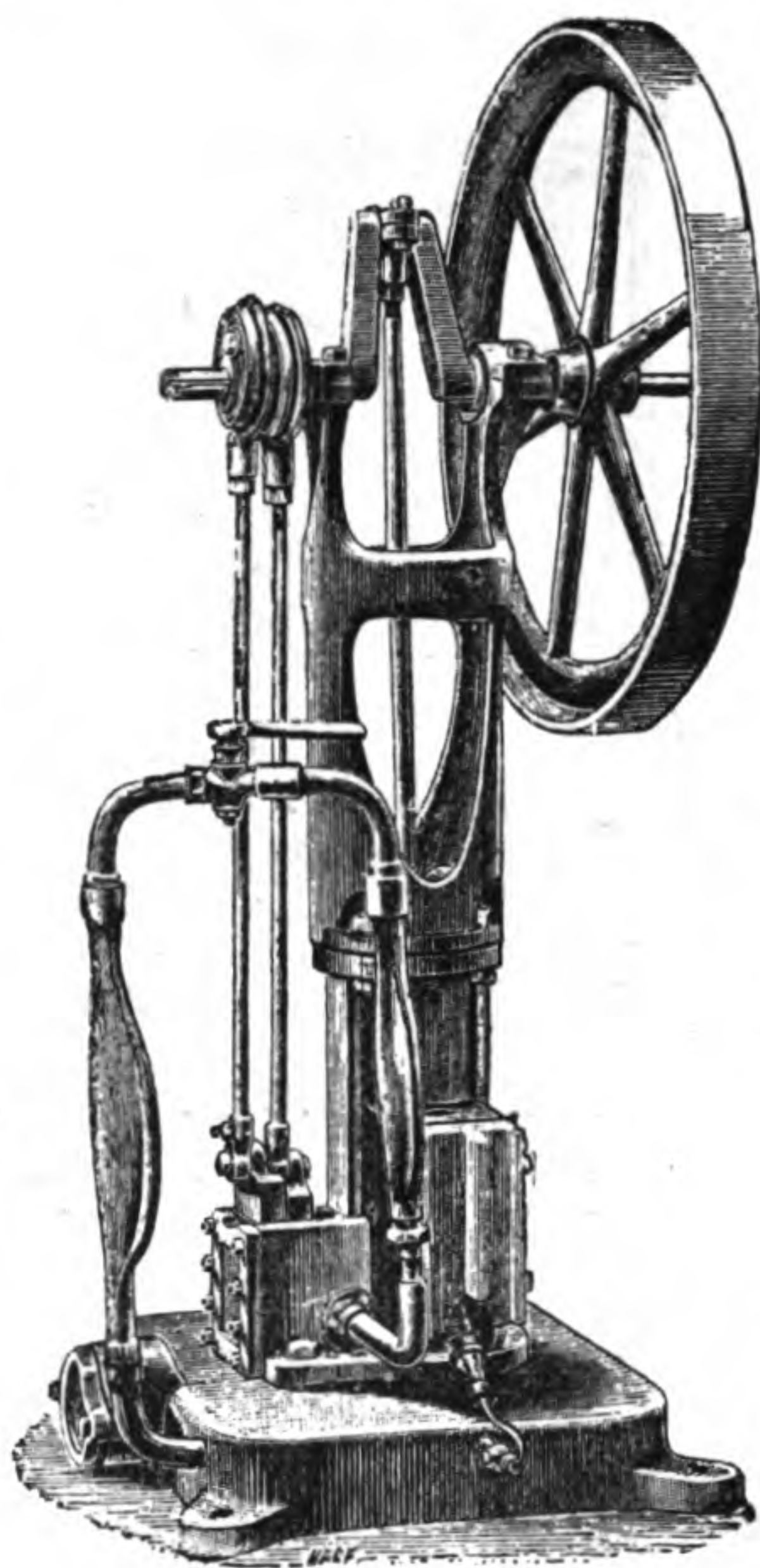

ONE MAN
POWER,
Suitable for
Lathes,
Printing Machines,
Sausage Machines,
and all
Light Machinery.

↔ **Price, as shown, £18.** ↔

The above Engine has been constructed to meet the demand for a really reliable, simple, durable Gas Engine, at a price which would bring it within the reach of all.

It is recommended with confidence.

ONE MAY BE SEEN AT THE

↔ **Britannia Co.'s Show Rooms,** ↔
100, HOUNDSDITCH, LONDON.

BRITANNIA WORKS, COLCHESTER, ENGLAND.

USEFUL SAW

FOR LIGHT WOOD OR METAL WORK.

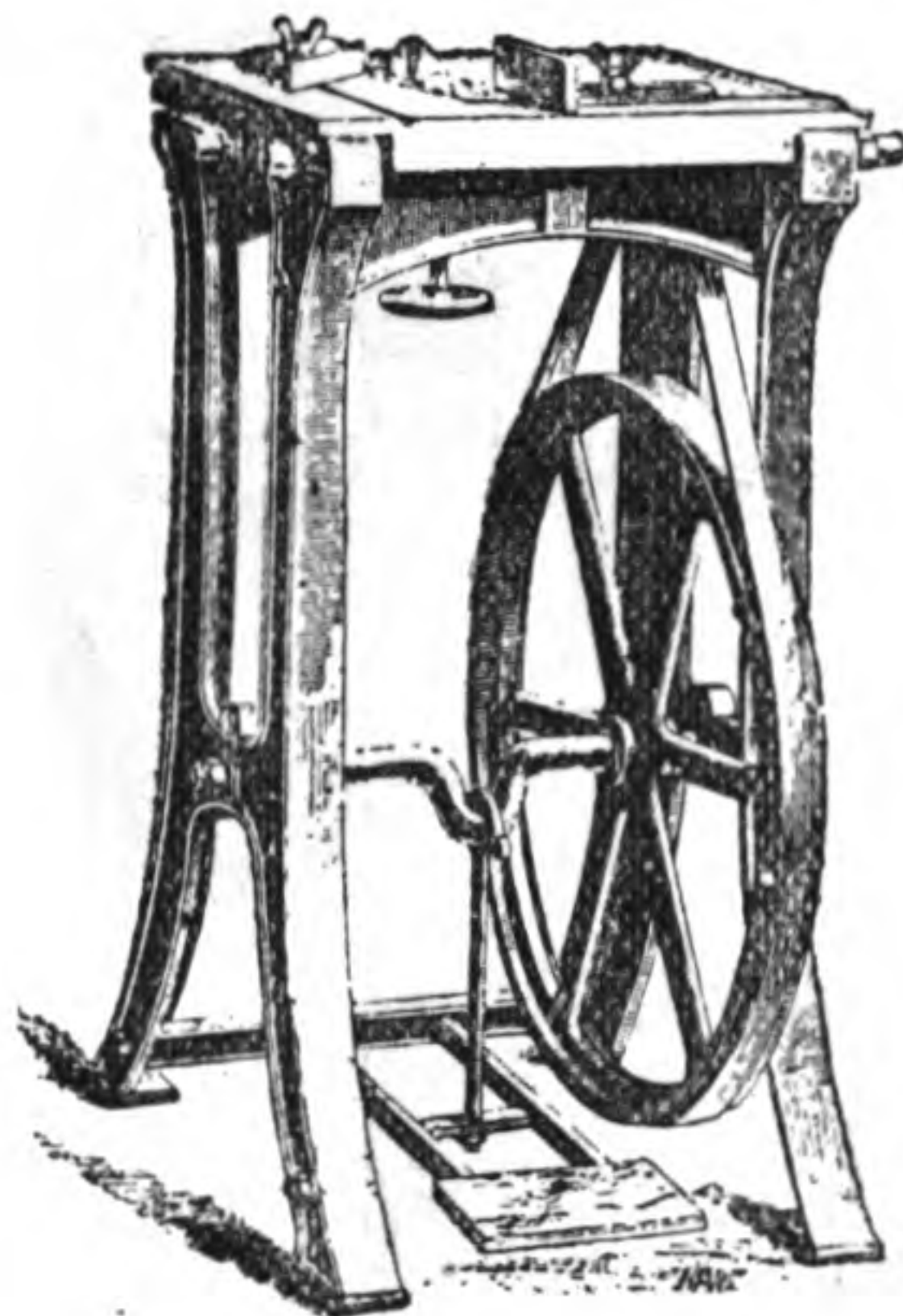

PRICE £8.

CHEAPER PATTERN, £6 10s.

FRET SAW. No. 3.

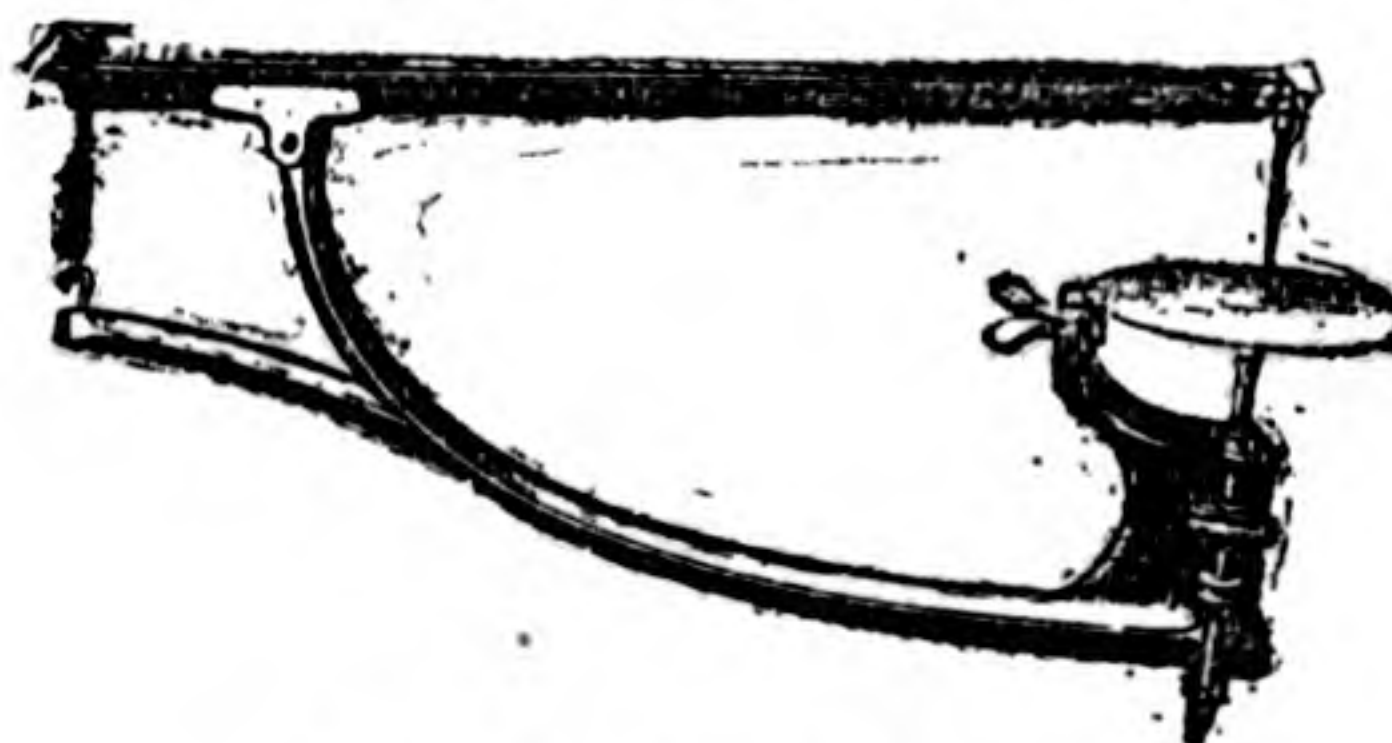

PRICE 30s.

Can be made for any Lathe. It is secured by a bolt and nut under the Lathe bed. Fixed in one minute.

NOTE.—In ordering, it is necessary to give the exact height from bed to centre, an accurate sketch or zinc template of size and form of Lathe bed, and to send the Lathe mandrel to fit the catchplate to nose-screw; or if a correctly-fitting chuck is sent, it will answer the latter purpose as well.

BRITANNIA WORKS, COLCHESTER, ENGLAND.

THE NEW PATENT SAW.

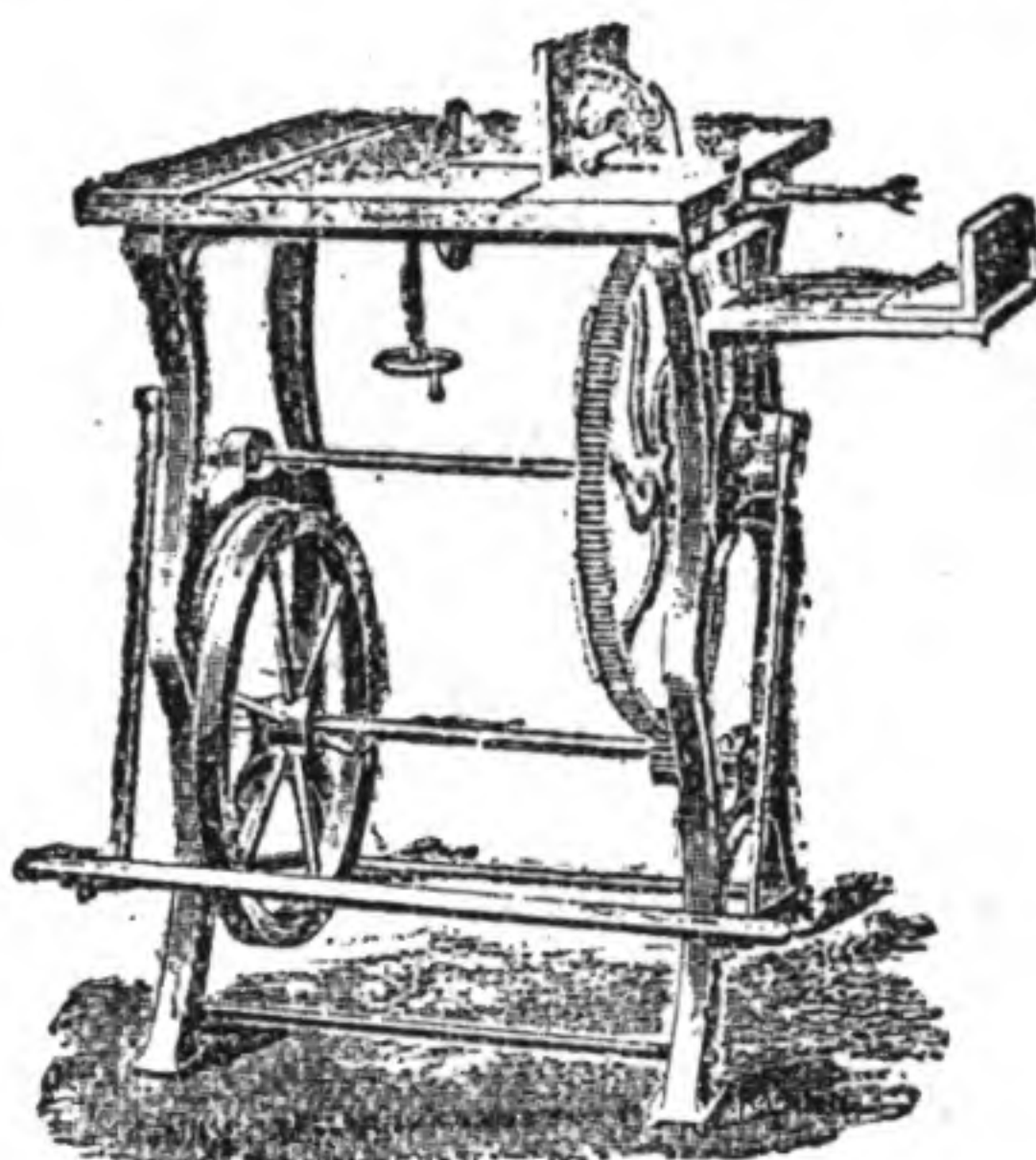

Including one each 8in. Rip and Cross-Cut Saws, and one 6in. Saw, with one pair of Bevel Washers for Grooving, £15.

Fret Arm to suspend from ceiling, for Fret Cutting, £2 10s.

Two Mitre and Cross-Cut Gauges, 17/6.

If 12in. Cross-Cut Saw instead of 8in., 5/- extra.

Adjustable Table at side, including Chuck for holding Bits of various sizes, 22/6.

Centre-Bits fitted: $\frac{1}{4}$, 8d.; $\frac{3}{8}$, 8d.; $\frac{1}{2}$, 8d.; $\frac{3}{4}$, 8d.; 1, 10d.; $1\frac{1}{8}$, 1/-; $1\frac{1}{4}$, 1/-; $1\frac{1}{2}$, 1/3.

The Saw can be worked at 1500 Revolutions per Minute.

A Handle at left—can be used as auxiliary to, or in lieu of, Treadle—price 7/6.

This Saw will cut 10ft. of inch wood in a minute.

Especially adapted for Pattern Makers, Cabinet Makers, Joiners, Picture Frame Makers; for Circular Groove Cutting, Dowelling, and Drilling.

BRITANNIA WORKS, COLCHESTER, ENGLAND.



FRET SAW, No. 4. 17s. 6d.

NOTE.

*The Britannia Company
make several patterns of Fret
Saws, as per their Fret Saw
List.*

THE BRITANNIA COMPANY'S

"Windsor" Fret Saw, No. 4,

IS constructed entirely of iron and steel, except the arms, which are of tough wood for quietness and lightness. The work table is 32in. from the floor, and is made to tilt for inlaying. The upper arm throws back to enable the end of the saw to be inserted for internal work.

The stand is nicely japanned. The driving wheel is 12in. in diameter, with a 5in. balance wheel. It will admit 18in. under the arm. The saw clamps are hung on pivots, and will hold firmly the finest or coarsest saw. It is fitted with an automatic blower and a drill shaft. A drill, wrench, and six saws accompany each machine.

The most surprising thing of all, however, is its cheapness, for the

PRICE IS ONLY 17s. 6d.

If required to be sent by rail—Box to pack, 2s.

Testimonials.

"I received the WINDSOR quite safely a few days ago. I put it together the same night, and find that it *works very well indeed*, and shall recommend it to my friends."

"I have to-day returned the case the WINDSOR came in. I have tried the Machine, and *like it very much*."

"I received the Machine yesterday, in proper order, and find that it works *in a very satisfactory manner*."

BRITANNIA WORKS, COLCHESTER, ENGLAND.

ADVERTISEMENTS.

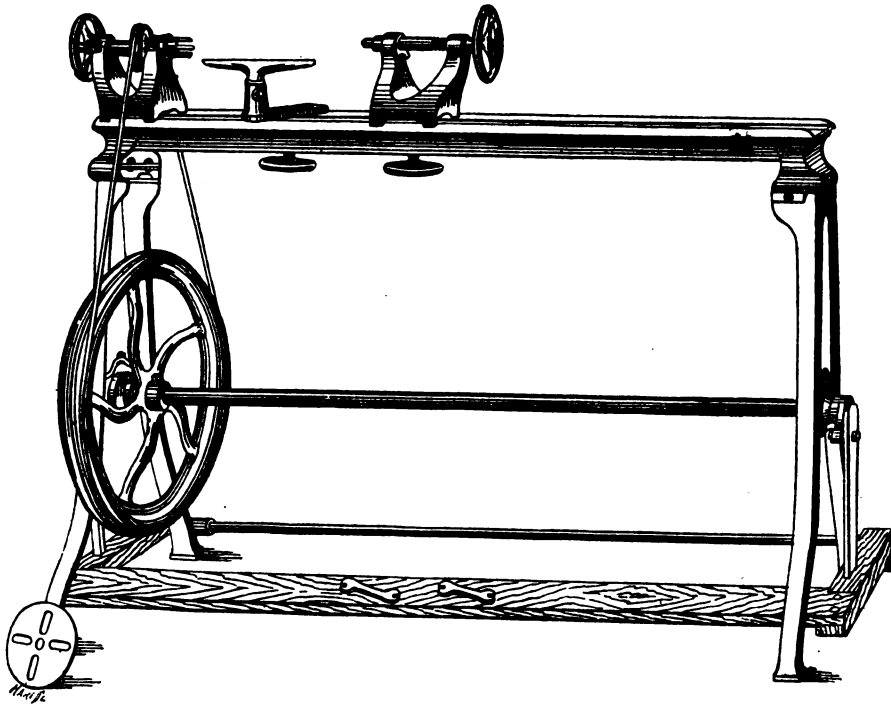

THE MULTUM IN PARVO LATHE

NO. 10.

Price £4 10s. 4ft. Bed, 5in. Centres.

A Light Lathe for Wood-Turning. Suited for Pattern Makers
and Amateurs who will not pay a higher price.

MAKERS—

BRITANNIA CO., COLCHESTER.

BRITANNIA WORKS, COLCHESTER, ENGLAND.

1911

1911

Site
photo

UNIVERSITY OF MICHIGAN



3 9015 03511 6691

