



This is a digital copy of a book that was preserved for generations on library shelves before it was carefully scanned by Google as part of a project to make the world's books discoverable online.

It has survived long enough for the copyright to expire and the book to enter the public domain. A public domain book is one that was never subject to copyright or whose legal copyright term has expired. Whether a book is in the public domain may vary country to country. Public domain books are our gateways to the past, representing a wealth of history, culture and knowledge that's often difficult to discover.

Marks, notations and other marginalia present in the original volume will appear in this file - a reminder of this book's long journey from the publisher to a library and finally to you.

Usage guidelines

Google is proud to partner with libraries to digitize public domain materials and make them widely accessible. Public domain books belong to the public and we are merely their custodians. Nevertheless, this work is expensive, so in order to keep providing this resource, we have taken steps to prevent abuse by commercial parties, including placing technical restrictions on automated querying.

We also ask that you:

- + *Make non-commercial use of the files* We designed Google Book Search for use by individuals, and we request that you use these files for personal, non-commercial purposes.
- + *Refrain from automated querying* Do not send automated queries of any sort to Google's system: If you are conducting research on machine translation, optical character recognition or other areas where access to a large amount of text is helpful, please contact us. We encourage the use of public domain materials for these purposes and may be able to help.
- + *Maintain attribution* The Google "watermark" you see on each file is essential for informing people about this project and helping them find additional materials through Google Book Search. Please do not remove it.
- + *Keep it legal* Whatever your use, remember that you are responsible for ensuring that what you are doing is legal. Do not assume that just because we believe a book is in the public domain for users in the United States, that the work is also in the public domain for users in other countries. Whether a book is still in copyright varies from country to country, and we can't offer guidance on whether any specific use of any specific book is allowed. Please do not assume that a book's appearance in Google Book Search means it can be used in any manner anywhere in the world. Copyright infringement liability can be quite severe.

About Google Book Search

Google's mission is to organize the world's information and to make it universally accessible and useful. Google Book Search helps readers discover the world's books while helping authors and publishers reach new audiences. You can search through the full text of this book on the web at <http://books.google.com/>

Stanford University Libraries



36105020077199

ORNAMENTAL TURNING

J·H·EVANS

Digitized by Google

621.9+

E 92



a

RECENT
WORKS ON THE LATHE

BY THE REV. JAMES LUKIN, B.A.

TURNING FOR BEGINNERS.

Cloth. 1s. 6d. net.

POSSIBILITIES OF SMALL LATHES.

Cloth. 1s. 6d. net.

SIMPLE DECORATIVE LATHE WORK.

Cloth. 2s. 6d. net.

BY J. H. EVANS.

ORNAMENTAL TURNING.

3 vols. Cloth. 3s. 6d. net, each.

GUILBERT PITMAN,

85, 86, & 87, FLEET STREET, LONDON, E.C.

ORNAMENTAL TURNING

J

ORNAMENTAL TURNING

A WORK OF PRACTICAL INSTRUCTION IN
THE ABOVE ART

BY

J. H. EVANS

IN THREE VOLUMES

VOLUME III

WITH NUMEROUS ENGRAVINGS AND PLATES

LONDON

GUILBERT PITMAN

86 & 87, FLEET STREET, E.C.

1904

MAY BE HAD THROUGH ALL BOOKSELLERS

137250

PRINTED BY
WILLIAM CLOWES AND SONS, LIMITED,
LONDON AND BECCLES.

WILLIAM CLOWES AND SONS, LIMITED,
LONDON AND BECCLES.

[ENTERED AT STATIONERS' HALL.]
(All rights reserved.)

CONTENTS OF THIRD VOLUME.

CHAPTER I.

THE SEGMENT APPARATUS.

	PAGE
Description of the Apparatus as made in the simple form—Also as fitted with the Worm-wheel and Tangent-screw—Improved Spring Action to keep the Screw from contact with the Wheel, when not in use—Reference to improved action, in preference to the Cam—Description of the Apparatus employed as a means of sub-dividing the work—Also as a Dividing and Wheel-cutting machine, as arranged for the Earl of Crawford and Balcarres	1

CHAPTER II.

THE SPIRAL APPARATUS.

Description of the Apparatus as fitted to the front of the Lathe-head—Mode of Manufacture—Explanation of the advantages of the Worm-wheel and Tangent-screw in preference to the Ratchet and Detent—Engraving of the Apparatus as thus fitted—Details of the improved arrangement of the Apparatus as fitted to the back of the Lathe-head—Full-page engraving of complete Lathe-head with it attached—Its employment in combination with the Ellipse Chuck—Improved Universal Joint—Engraving of Second View, illustrating the Dividing Chuck and Divisions on Worm-wheel—Mode of Hinging the Frame of Tangent-screw—Illustration of extra Arbor, designed by the author, to increase the length of twist—Explanation of the advantages claimed and due to the arrangement	7
---	---

CHAPTER III.

THE SURFACE SPIRAL.

	PAGE
Details of the manner in which the Apparatus is made and attached to the Lathe—Its connection to the Mandrel and Slide-rest by Mitre and Round-edged Wheels—Application of two Universal Joints, to combine the motion of the Mandrel with the Slide-rest, without the necessity for Mitre-wheels—Engravings of the Apparatus	21

CHAPTER IV.

THE RECIPROCATOR.

Engravings of the Instrument (two views), showing improvements in its construction—Details of its Manufacture—Table of Change-wheels for Single Gearing—Also for Double Gearing	25
---	----

CHAPTER V.

MANIPULATION OF THE SPIRAL APPARATUS.

Description of the Apparatus as applied to the production of Fine Threads—Also those of longer Pitches, produced by Double Gearing, rendering more appropriate work for Decorative purposes—Compound Spiral Turning—Plates of Specimens of Work	34
---	----

CHAPTER VI.

THE SPIRAL APPARATUS AND ELLIPSE CHUCK IN COMBINATION.

Plate of Elliptic Casket—Manner of reproduction—Details of the necessary settings	51
---	----

CHAPTER VII.

EXAMPLES OF SURFACE SPIRALS AND RECIPROCATOR.

Plate of examples of work produced by connecting the Slide-rest to the Spiral Apparatus, when the former is set at a right angle to the Lathe-bed—Examples of patterns emanating from the employment of the Reciprocator—Full details of the various settings and instruments used	54
--	----

CHAPTER VIII.

IVORY CANDELABRA.

	PAGE
The selection of the material—Necessity for maintaining the proportions of the design—Plate of specimen Candelabra in ivory, with six branches, and Centre Tazza and Sconce—Details and settings to facilitate its reproduction	68

CHAPTER IX.

THE SPHERICAL SLIDE-REST.

Illustration—Full details of its Manufacture—Description of Improvements—Reference to importance of the Segment-stop with Adjusting Screws—Also the additional Arm to receive the Wheels of the Spiral Apparatus	79
--	----

CHAPTER X.

MANIPULATION OF THE SPHERICAL REST.

Diagram and Illustration of Curved Tools—Engravings of Circular Parting-tools, invented and patented by the Rev. C. C. Ellison—Plate of Specimen of Work, also by Mr. Ellison—Instruction and Settings for its reproduction	87
---	----

CHAPTER XI.

VASE ORNAMENTED WITH SPHERICAL SLIDE-REST.

Plate of Vase—Details of Settings and Instruments required in its reproduction	101
--	-----

CHAPTER XII.

ELLIPTIC CASKET.

Plate—Description of the manner of Chucking the various parts—Arrangements required to reproduce it	111
---	-----

CHAPTER XIII.

THE GEOMETRIC SLIDE-REST.

	PAGE
Engraving of the Apparatus, as invented and patented by Capt. R. Pudsey Dawson—Explanation of its connection with the Spiral Apparatus, by which the various Geometrical Designs are obtained—Six Examples, showing the results—Details of Manipulation	120

CHAPTER XIV.

THE ELLIPSE CUTTER.

Engraving of the Instrument—Full details of its Manufacture—Reference to the inventor, Major James Ash—Mr. Perigal's Completion of the Instrument by addition of Worm-wheel and Tangent-screw—Description of Primary Examples of work to be produced by its employment	128
--	-----

CHAPTER XV.

THE EPICYCLOIDAL CUTTER.

Two Engravings of the Instrument—Its Manufacture—Description of various Improvements fully entered into—Engraving of small Drilling Instrument and Eccentric Cutter designed by the author—Manipulation of the Instrument	140
---	-----

CHAPTER XVI.

THE ROSE CUTTER.

Engraving of the Instrument—Necessary Details for its Manufacture—Six primary Examples of its Employment—Application of the small Drilling Instrument and Eccentric Cutter, to extend the variety of work	152
---	-----

ILLUSTRATIONS OF THIRD VOLUME.



FIG.	PAGE
168A. THE SPIRAL APPARATUS	8
169. THE SPIRAL APPARATUS	14
169*. THE SPIRAL APPARATUS	16
169B. ADDITIONAL ARBOR FOR SPIRAL APPARATUS	19
170. THE SURFACE SPIRAL	23
170A. DOUBLE UNIVERSAL JOINTS	24
171, 172. RECIPROCATORS	26
173. THE SPHERICAL SLIDE-REST	79
174-177. SPHERICAL PARTING TOOLS	91
178-179. CURVED TOOLS—DIAGRAM ILLUSTRATING CURVES	93
180. THE GEOMETRIC SLIDE-REST	120
180*. SIX EXAMPLES OF WORK PRODUCED BY THE GEOMETRIC SLIDE-REST.	122, 124, 126
181. THE ELLIPSE CUTTER	128
182. THE EPICYCLOIDAL CUTTER	140
183, 184. THE EPICYCLOIDAL CUTTER	147
185. THE EPICYCLOIDAL CUTTER	140
186. THE ROSE CUTTER	153
187-192. SIX EXAMPLES OF WORK PRODUCED BY THE ROSE CUTTER	156, 160, 162

PLATES OF THIRD VOLUME.

PLATE	PAGE
10. SPECIMENS OF WORK PRODUCED WITH THE SPIRAL APPARATUS	37
11. SPECIMEN OF COMPOUND SPIRAL TURNING, EXECUTED BY CAPT. R. PUDSEY DAWSON	43
11A. SPECIMEN ILLUSTRATING A FURTHER APPLICATION OF THE SPIRAL APPARATUS	44
12. EXAMPLES OF SURFACE SPIRAL DECORATION, PRODUCED BY THE RECIPROCATOR	55
13. IVORY CANDELABRA FOR SEVEN CANDLES	71
14. SPECIMEN VASE, TURNED BY THE REV. C. C. ELLISON, EMPLOYING THE ROSE ENGINE, ELLIPSE CHUCK, AND SPHERICAL SLIDE-REST	95
15. VASE WITH DEEP BASE, TURNED AND ORNAMENTED WITH THE SPHERICAL SLIDE-REST	103
16. IVORY ELLIPTIC CASKET, TURNED WITH THE SPHERICAL SLIDE-REST AND ELLIPSE CHUCK	113

ORNAMENTAL TURNING.



CHAPTER I.

THE SEGMENT APPARATUS.

THIS apparatus has been referred to in the previous volume, wherein its employment in combination with the various ornamental chucks, especially the dome chuck, is clearly detailed, but although it has been explained, and repeatedly noticed with regard to many of the examples contained in the plates, it is necessary that the entire details connected with its manufacture and further uses should be described, so that if desired the more simple form may be first added to the lathe, and afterwards completed by the addition of the worm-wheel and tangent-screw.

The plain form consists of a gun-metal disc, which is attached to the back of the pulley, and has a wide rim on its face, through which seventy-two holes are drilled equidistantly, and afterwards made taper with a broach of the necessary form. These holes are to

receive the steel pins which act as stops, to decide the length of the segment of the circle to be cut.

On the periphery of the disc a line is marked across the full width, opposite every sixth hole, and figures engraved to denote the same, thus: 72, 6, 12, 18, 24, and so on, round the entire number. A stout steel post is fixed to stand vertically on the lathe-head, and is sunk into the mandrel frame at the base, and fixed by a strong screw; at the top it is turned to a right angle, and has through the projection a capstan-head screw, on each side, upon which, when employed, the pins that fit into the holes in the plate take effect. The screws are made to adjust in each direction, so that any distance less than the space of one hole may be obtained, and it is necessary to be sure that the screws are partially withdrawn, so that their movement may be available for this purpose.

Many very elegant patterns are, with the aid of this apparatus, cut on the faces of different objects, such figures consisting of arcs of circles, grouped and arranged to form various designs; and to enlarge upon this particular form of work it is necessary at the same time to employ the eccentric or other of the ornamental chucks, in order that the different cuts may be placed in positions varying from concentricity to the axis of the work.

The foregoing remarks are sufficient to show how

the simple form of segment apparatus is made and attached to the lathe-head, but in this form it can only be considered quite a primary attachment, which has been much improved by the addition of the worm-wheel and tangent-screw.

This is illustrated by Figs. 1, 2, and 169, the latter being the engraving of a complete lathe-head; and it will be seen that the metal disc and steel vertical post, with its capstan-head adjusting-screw, are in every way similar to that already described for the plain segment apparatus. The periphery of the disc is then cut to a worm-wheel of one hundred and eighty teeth, and this is actuated by a tangent-screw, which is fitted into a strong metal frame, hinged on centres in a frame at the back of the lathe-head, and moved in and out of gear by a steel cam, which is worked by a square that receives a key, a steel projection being let into the casting upon which the cam works. Towards the front, two steel pillars are screwed into the head, and filed away to the half, so that the metal frame moves within them, and is thus prevented from any movement, except that required to raise and lower it.

This particular action has rather a disadvantage, inasmuch as it is likely to be accidentally raised, and thus damage the teeth of the wheel if the mandrel should be rotated. To avoid this the author has now introduced a spring underneath the frame, which keeps

the screw from inadvertent displacement. The following arrangement is also an improvement, as it admits of the screw being firmly retained, either in or out of gear. The cam is dispensed with, and the end of the frame made to correspond with the arc of a circle described from the centre-screws at the back. A block of steel is then fixed to the lathe-head, with a projection to fit the metal arc; through the front an elongated hole is made, a screw passing through it into the steel block. The tangent-screw may be raised to gear with the wheel, and there secured by the fixing-screw, and, when freed from the same, it may also be fixed, and be prevented from accidentally coming in contact with the wheel and spoiling the teeth.

It will be obvious that by the introduction of the worm-wheel a slow speed is obtained, by which the mandrel is rotated between the limits of the two pins, when adjusted for any length of segment; and while cutting deep mouldings this is most essential, as the hand has not sufficient command over the pulley to ensure smooth and perfect cutting.

As previously stated, the various chucks, such as the eccentric, rectilinear, dome, etc., are adjusted to, and held in the required position, and the weight of the latter, from the fact of the horizontal arm extending so much on one side of the centre, renders the worm-wheel almost indispensable.

The benefit of this addition is not confined to the advantages already described. It will be seen by reference to the engraving, Fig. 169, that on the end of the tangent-screw a micrometer is fitted, and divided into ten equal parts; the worm-wheel and screw may be used in place of the index-point and division on the pulley face, and for many purposes it is more appropriate. When employed as the means of dividing and sub-dividing the work, it must be remembered that the wheel has one hundred and eighty teeth, therefore one complete rotation of the tangent-screw moves the mandrel through precisely the $\frac{1}{180}$ part of its diameter, and that the number of cuts or spaces upon the work result from the revolutions of the screw, or partial movement of the same, indicated by the division on the micrometer, read from a line on the frame; for instance, two turns of the screw gives ninety consecutive cuts, while four result in forty-five equal spaces. Against these movements, it will be obvious that one half-turn of the screw gives three hundred and sixty divisions.

Fractions of turns of the screw are obtained by the addition of extra micrometers, divided to 8, 9, 11, 12, and many others, any one of which numbers may be employed, and the apparatus may in consequence be used as a dividing engine for wheel-cutting; and again, with the worm-wheel and tangent-screw in gear, combined with the rectilinear and dome chucks, the whole

becomes, so to speak, a complete shaping-machine, by which the various subjects previously alluded to are produced.

As a dividing engine, the author was honoured with the order to fit one to a lathe made by him for the Earl of Crawford and Balcarres, and this was fitted to work at the top of the worm-wheel, and by an arrangement of arbors to carry wheels similar to those used on the geometric chuck, a most complete dividing and wheel-cutting apparatus was produced, the position for each succeeding cut being indicated by a detent falling into a notch on the collar of the spindle, and by various collars having different numbers of notches, combined with a full set of change-wheels, the addition was a complete success. A scale of the movements of the tangent-screw to produce from three hundred and sixty to almost any number of lines may be worked out, but this will be of small value to ornamental turners, as the segment apparatus is seldom used for such purposes, and the value of its movement is found in its employment as described, in connection with the dome and other chucks, for the production and decoration of compound solid forms.

CHAPTER II.

THE SPIRAL APPARATUS.

THIS apparatus may be fairly considered as indispensable to a complete ornamental turning lathe, and as it can be attached in two ways, it is considered necessary to fully explain both methods, in order that the distinct merits of the improved plan, as at present fitted to the back of the lathe-head, may be clear and appreciable.

The engraving (Fig. 168A) represents the apparatus as fitted in what may now be considered the old plan—at the front of the lathe-head. A radial arm, it will be seen, is arranged to partially rotate in a circular groove cut in the front of the lathe-head, concentric to the mandrel axis, and is held by a steel binding bolt, which passes through a curved slot at the lower extremity of the arm. The head of the screw is made hexagonal to fit a spanner, which, for all such screws, is 1 in. across the flat; it is also drilled to receive the point of a bent lever, which, in many instances, is more convenient than the spanner to loosen it, when it

is necessary to raise or depress the arm. The long mortise slot is then filed out perfectly parallel and square, so that the arbors which carry the wheels will slide from end to end, and fix at any desired position.

The bodies of the arbors are made of gun-metal, having a flange on one end to bear against the side of

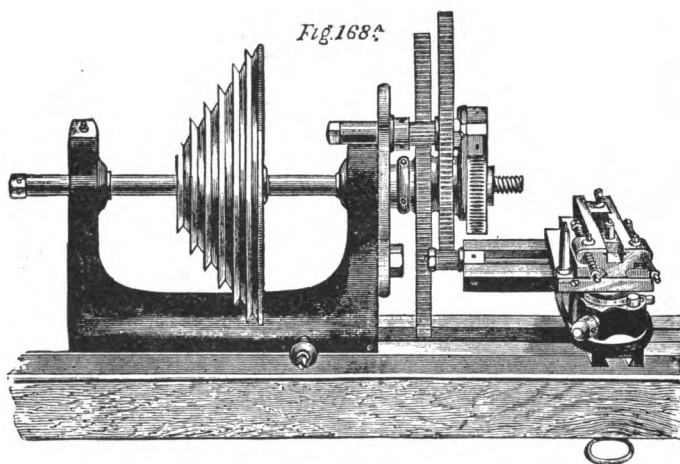

the arm, and are screwed at the other to receive a tubular nut, also made of gun-metal, and passes over that part which projects through the arm. When the screw is cut, the sides are filed away equally, till the body will fit into the mortise and move freely; the end of the nut is then filed to fit the standard spanner.

Through the body of the arbor a steel spindle,

with a collar $1\frac{1}{4}$ in. in diameter in the centre, is fitted, the hole to receive it being tapered about 2° . The spindle must be well fitted and the face of the collar bear against the flange of the metal. A steel screw is then fitted into the end to keep it in its place, the head of the screw being rather less in diameter than the width of the parallel slot through which it has to pass when fixed to the radial arm.

The projecting end of the steel spindle is then turned to fit the small wheels, which are termed pinions, the holes in which are $\frac{1}{2}$ in. in diameter; it is then screwed at the end to receive a steel nut similar to those previously described, but only $\frac{3}{8}$ in. thick, and this has a thin steel washer before it. The double and single arbors are identical in every respect, with the exception of the total length of the spindle from the face of the collar, the former being long enough to receive two wheels, which are used in double gearing; the latter holding one only for a single train, in which case the wheels all run in the same plane. It is necessary that the spindle which passes through the metal body should be always kept close to the flange, as it is upon this that the wheels revolve, when in action.

The intermediate or reversing arbor is made in a different way, being composed entirely of steel; a wheel of thirty teeth is fitted to work permanently upon it; it is also filed to fit the parallel slot, and has

a corresponding steel nut to fix it. This arbor is of very considerable importance, as its intervention reverses the action of the apparatus for the production of left-hand screws and spirals. Its application will be referred to in connection with the various specimens of spiral work. In fitting up these arbors, care must be taken that the diameters of the various parts do not prevent the 30 wheel on the intermediate one being placed in gear with the small pinion on the double arbor.

The dividing chuck forms a most important part of the apparatus; it is made from a solid casting, the body of which is long enough to admit of the wheels being arranged upon it to run in the same plane as those on the arbor, when fixed in the arm. It is screwed to fit the mandrel nose, and the external diameter turned to fit the holes in the large wheels, which are $1\frac{1}{4}$ in. in diameter; the body of the chuck is turned away at the back until the wheels are all in one plane. It is then screwed with a fine thread, and a circular steel nut and washer fitted, to bind the wheels securely to it; the edge of the nut is drilled to receive the end of the lever by which it is tightened. This is preferable to the original plan of drilling small holes in the face of the nut, which necessitated the use of a pin-wrench, and was found at times inconvenient, and consequently discarded.

The front of the chuck is bored out to receive the stem of the worm-wheel, which must also be well fitted, and have a substantial face bearing on the front ; it is held by a steel screw, fitted into the stem of the wheel, and is passed up the hole where the chuck is screwed to fit the nose of the mandrel, and the bottom of the hole being turned perfectly true, the wheel revolves between it and the front face.

A metal frame with steel tangent-screw is then fitted so that it can be moved in and out of gear, and to obtain this action a steel screw is fitted firmly into the lower side of the frame and has a plain part larger than the thread, which is screwed tightly to the latter, the head just bearing against the face of the projection on the chuck, thus forming a centre, or hinge ; a milled head-screw is fitted to the opposite end, the plain part of which moves in a curved slot, long enough to obtain sufficient movement, and by this it is fixed in either position as required. This action is the most convenient for the chuck under consideration, as it is at times necessary to place the slide-rest in such close proximity to it that the cam, as advocated in other chucks, is somewhat in the way.

The worm-wheel and tangent-screw has many advantages over the original, and now obsolete ratchet-wheel and detent ; one particular disadvantage in the latter being an inclination to slip, which may arise

from any undue amount of force being required to remove a metal chuck from the nose. This defect has been referred to, as applied to the eccentric and ellipse chucks of ancient patterns. Another important advantage derived from the worm-wheel is, that it can be divided into any fractional part of a whole turn of the tangent-screw; and this, for various necessary adjustments, is of much importance.

For all screw-cutting and spiral-turning, ninety-six equal divisions are sufficient, and practically more than are likely to be required, but the worm-wheel, for the reasons given, is vastly superior; the ratchet has, therefore, long been discarded in modern lathes.

The worm-wheel is divided on the edge at every complete turn of the tangent-screw, and figured at every 6, the collar on the screw is divided into eight equal parts, a steel reader or index being fitted on each side to read the divisions on the periphery, which agree with the zero on the screw-head. The end of the slide-rest screw is fitted with a socket to carry a wheel, as explained by the illustration (Fig. 13), that is, for the purpose of holding the various change-wheels used in the train, when in action. Here again the hexagonal nut takes the place of the round one, which, like the large one on the chuck, was originally drilled on the face for a pin-wrench.

Thus far it will be seen that the apparatus, as

fitted to the front of the lathe-head, consists of the radial arm, double, single, and intermediate, or reversing arbors, sixteen change-wheels and pinions, and the dividing chuck; the number of teeth contained in the several wheels are 144, 120, 96, 72, 60, 53, 50, 48, 36, 30, 24, 20, 18, 16, 15. The wheels that have large holes are, when required to be placed on the arbors, filled with a metal bush, which fits on to the arbor, and has a thin steel washer in front to extend beyond the diameter of the aperture.

Having described the apparatus as fitted to the front in this way, the following details of its arrangement at the back of the head, with its additions and improvements, will, it is hoped, clearly illustrate the benefits to be obtained by its aid when thus employed, and establish its superiority over the original and comparatively defective plan.

The engraving (Fig 169) represents the apparatus as arranged ready for use, the train of wheels being those which produce a twist of one turn in 7 in. approximately. It will be observed that the radial arm in this case is attached in precisely the same way, but to the opposite end of the lathe-head. The three arbors are also similar, being simply reversed in the arm, so that the wheels revolve on the left, instead of the right side of it.

Thus far the only alteration consists in reversing

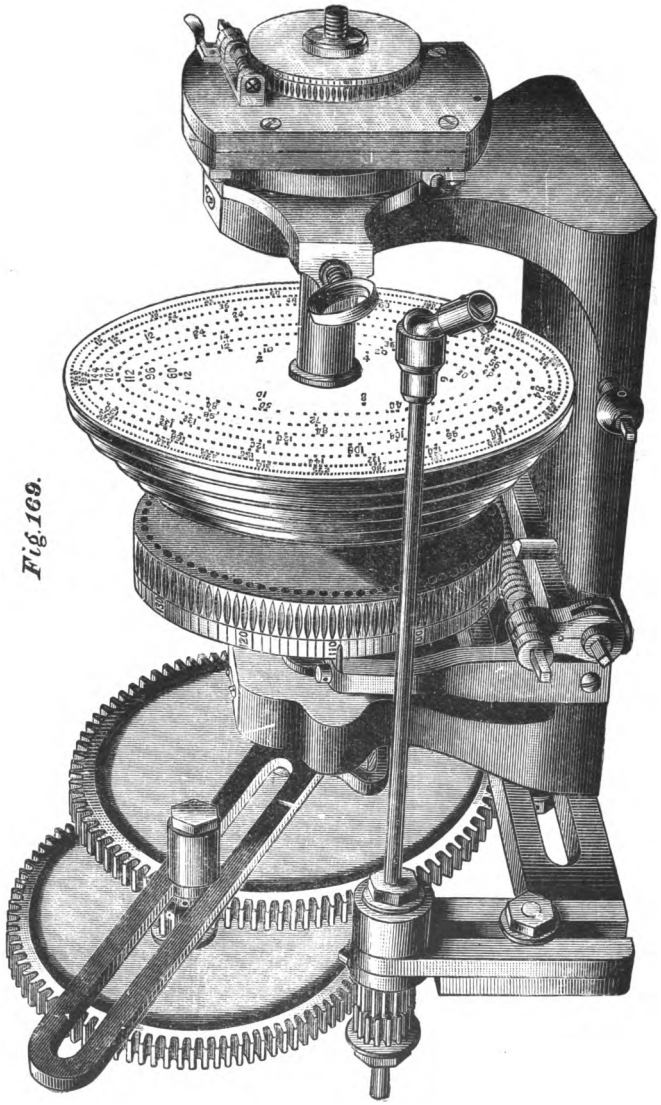

Fig. 169.

the arm and wheels to the position seen in the engraving. The dividing chuck, however, is of quite a different character, and is composed of a strong metal body of a tubular form, with a projection at the end. It is bored to fit on the end of the mandrel, the base of the hole being cut out to fit over the projection on the end, which is generally used for holding the screw-guide and steel cap or sleeve from moving round, when in operation. A hole is then bored through the end to allow the screw to pass into the end of the mandrel, which retains it in its necessary position. The body is then turned on the mandrel, or a supplementary arbor (the former being preferable, as it ensures perfect accuracy). The exact size of the tubular fitting cannot be given, as it varies according to the diameter of the mandrel.

The outer diameter of this part should be turned slightly taper, about 2° , and left as strong as possible. The worm-wheel is then bored out to fit it accurately, after which it is transferred to a separate arbor, and the periphery cut to a worm-wheel. This, like all wheels of a similar character, has ninety-six teeth, and is divided, as seen by Fig. 169*, on the back face into ninety-six equal parts, with a long line and numerals at every 6.

The steel tangent-screw is fitted into a metal

frame, which bears against the projecting flange of the body of the chuck, the screw by which it is held forming its centre of action, and the milled head screw on the right side used for clamping it when in or out of gear with the wheel. This screw passes through a short curved slot in the flange, and, when

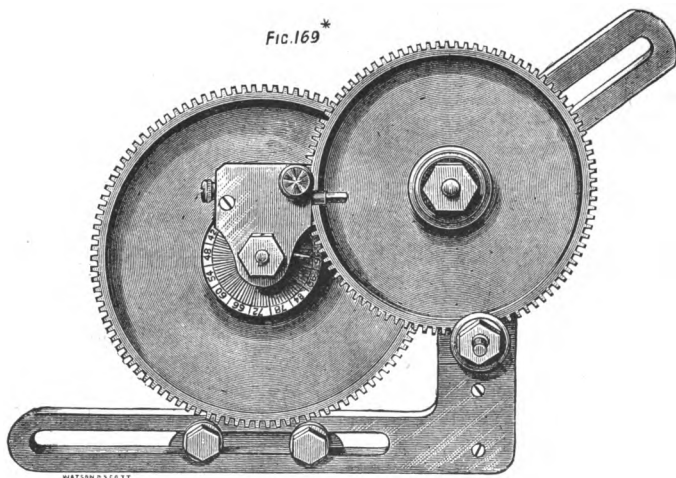

screwed up, brings the frame in close contact with it; thus, it will be observed, that when it is required to move the work round any desired portion of the entire circle, the milled head is released, and the tangent-screw raised; the mandrel is then moved round, carrying the work with it, also the body of the dividing chuck, and when the steel index points

to the number required, the screw is lowered into gear, and the fixing-screw tightened.

At the base of the headstock a straight arm (seen in Figs. 169 and 169 *) is fitted to move transversely, having a long parallel slot, and is fixed in its necessary position by two steel bolts with hexagonal heads, which, like that used for fixing the radial arm, are drilled to receive the bent lever.

On the front of this arm a metal frame, with a projecting boss on each side, is fitted, and slides on a steel fillet, fixed to the arm, so that it may be raised and depressed as required. It also affords a ready means of adjusting it to the height of the centre of the slide-rest screw. The cylinder boss is bored out to receive a steel socket, which revolves freely in it, and is retained in its place by a nut and washer. The projecting end of the socket is turned down to receive the pinions, which are $\frac{1}{2}$ in. in diameter, and are also held by a nut and washer. It is an advantage to have this fitting long enough to hold two wheels, therefore it should be 1 in. long in the plain part, and when a wheel is fixed to it, it bears the same reference to the train of wheels, and the pitch of the spiral cut, as when, in the preceding arrangement, it is fixed on the end of the main screw of the slide-rest.

Through the centre of this socket a long steel connecting-rod is fitted, being held at any distance by a

fixing-screw, the point of which fits into a groove cut the entire length of the rod. On the end of the connecting-rod an improved double, or universal joint, is attached, the end of which fits over the projecting socket on the slide-rest screw, and a screw passes through both to hold it in its place; and when the wheel on the arbor is placed in gear with that on the chuck, and the arm lowered so that the wheel also gears with that on the socket, the action of the whole train is obtained by turning the winch-handle of the slide-rest screw.

The universal joint, improved and introduced by the author, and applied to this particular purpose, has the advantage of allowing the slide-rest to be set to an angle, to turn a cone or a long taper spiral without the interposition of the extra surface spiral apparatus, with its round edge and bevel wheels—to be described in the following chapter.

The object of the adjustment in the lower straight arm is to allow the connecting-rod to be moved to or from the centre, to suit the various positions of the slide-rest for work of large or small diameters, and the vertical movement of the socket bears the same reference to the height of centre of the slide-rest screw when set above, below, or at the centre of the lathe axis.

Fig. 169B illustrates a still further addition and

improvement by the author, and is for the purpose of increasing the length in the twist of spiral. It is simply an additional arbor which can be fixed to the frame through which the socket holding the connecting-rod passes, and will carry two extra wheels to gear with the train already described ; this arrangement also disposes

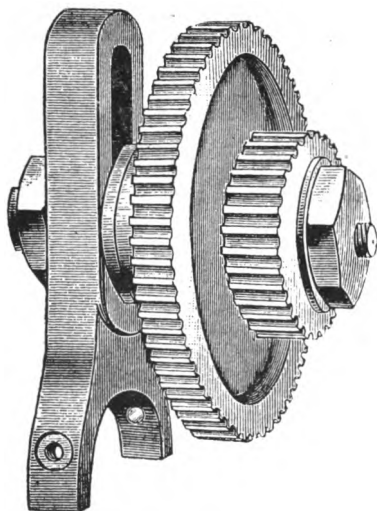

Fig. 169B.

of the surface spiral apparatus, which must be used for the same purpose when the apparatus is fitted to the front of the lathe-head.

Before giving the details of the various specimens illustrated in connection with this apparatus, it will be expedient to point out the advantages claimed, and due

to it, as attached to the lathe in the form we have just considered.

First, then, the extra length of the spiral chuck in the front is dispensed with, and the chuck which holds the work is placed direct on to the mandrel-nose; this decreases the tendency to vibration, and allows the work to be executed in closer proximity to the mandrel; the undue length of the chuck in front being at all times a disadvantage.

Secondly, the work remaining on the mandrel-nose does not require to be again turned, which is necessary when the apparatus is fitted to the front, as in Fig. 168A.

Thirdly, the greater part of the whole apparatus may be left in its place ready for future employment, thus saving a considerable amount of trouble and time.

Fourthly, the cutting of taper spirals can be effected by the aid of the universal joint, without any additional apparatus; and

Lastly, it enables the ellipse chuck to be used in conjunction with it, which combination renders some very beautiful work indeed; and, as the ellipse and spirals can be combined in no other way, it must be, as it is admitted, a very great improvement and advantage.

CHAPTER III.

THE SURFACE SPIRAL.

THIS is also an addition to the spiral apparatus, and is employed as a means of transferring the various spirals from the cylinder to the surface; it is also necessary for the same operation on cones, when the apparatus is fitted to the front of the lathe-head.

The apparatus (Fig. 170) consists of a cast-iron pedestal similar to the hand-rest for plain turning, but longer in the base, and is fixed to the lathe-bed, when required, in the same way, by a dovetail slide; a steel stem is then fitted to the pedestal, on which is fixed a metal barrel holding a socket, on one side of which the change-wheels and pinions are fixed, and through which a long steel rod is fitted, similar to that already explained; on the end of the rod a collar is fixed, to which a mitre or round-edged wheel is attached, when required, to connect the movement of the slide-rest with that of the other wheels of the train, and consequently that of the mandrel.

When setting up the apparatus, the rod should

stand parallel to the lathe-bed and the wheels as required, but generally speaking the mitre-wheel of thirty teeth is fixed to the rod, while that containing sixty teeth is attached to the end of the slide-rest screw, when it is placed at right angles to the lathe-bed, but when used for ornamenting cones the round-edged wheel and pinion are substituted. The rod having a longitudinal movement, the wheels may be geared, when the slide-rest is set at varying distances from the mandrel-nose, to suit the different depths of the chuck and material to be operated upon, while the transverse adjustment admits of work of large or small diameter being accommodated, and when these are finally and satisfactorily adjusted, the stem is fixed by the binding screw in the pedestal, and the point of the screw placed in the groove of the sliding-rod, thus retaining the various fittings in their several places.

Fig. 170A illustrates a method designed by the author for effecting the same purpose as the surface spiral apparatus referred to; it will be observed that the mitre and round-edged wheels are entirely dispensed with, and the motion is obtained by the application of two double universal joints, one of which is attached to the rod A, which passes through the barrel in the pedestal, while the second, C, is fixed to the socket on the end of the main screw of the slide-rest, the two being connected by the socket

on each, secured by the screw D. By the aid of these joints the slide-rest may be set to any degree between the parallel and right angle.

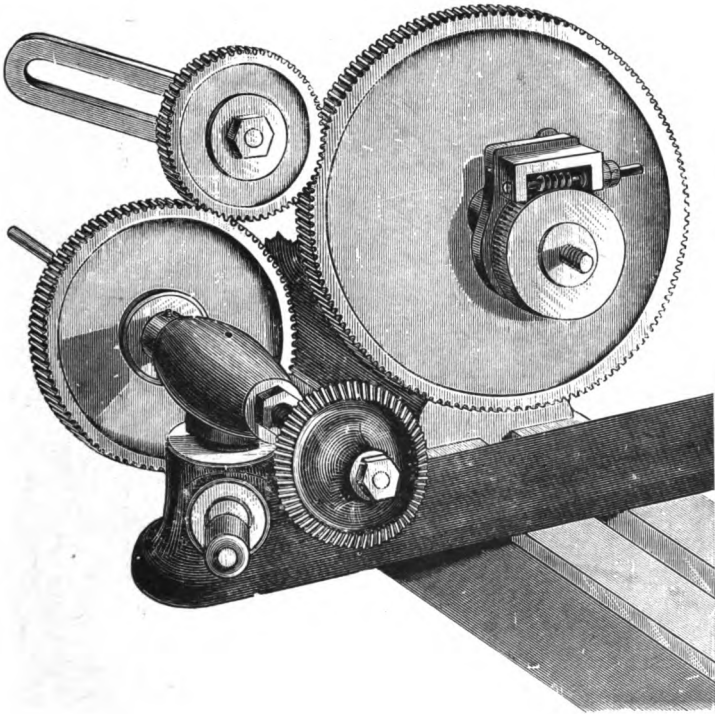
Fig 170

This comparatively simple arrangement works perfectly, and is now fitted to the lathes of many amateurs; it is less trouble to mount, and relieves

the spiral apparatus of the inherent loss of time derived from the extra wheels; and further, the work produced by the different trains of wheels employed

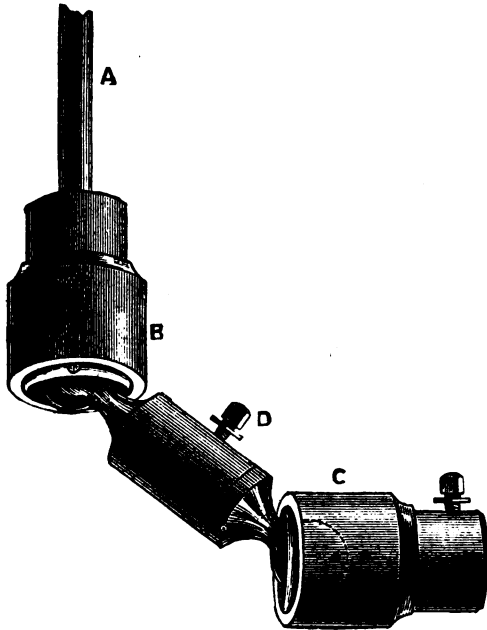

Fig. 170A.

upon cylinders may be transferred to the surface, without differing in any way by the introduction of extra gearing.

CHAPTER IV.

THE RECIPROCATOR.

THIS instrument affords the means of obtaining a still wider variation of effect, and it may also be considered a very important addition to the spiral apparatus. It can be applied to either the cylinder or surface with equal facility. It will be seen, by reference to the engraving (Fig. 171), that it is composed of two steel arms with circular ends, the short one, which has the series of holes drilled in it, is made to fit on the dividing chuck, and is attached there by the same nut and washer that hold the wheels; the longer arm of the two is fitted to revolve on a metal bush with a plate on the front; the bush is made the same width as the pinions, $\frac{1}{2}$ in. wide, and it will be observed that it has two holes bored through the face, which are marked A and B, the former having an eccentricity of $\frac{3}{20}$, while the latter has twice the amount. On the opposite side of the centre, the holes are made to fit on the double arbor, and are therefore also $\frac{1}{2}$ in. in diameter.

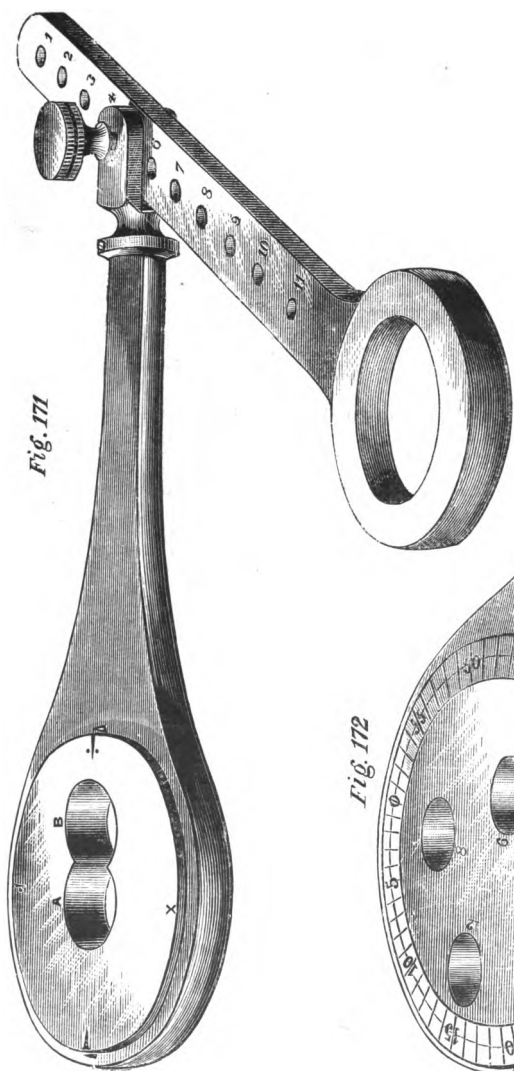

Fig. 171

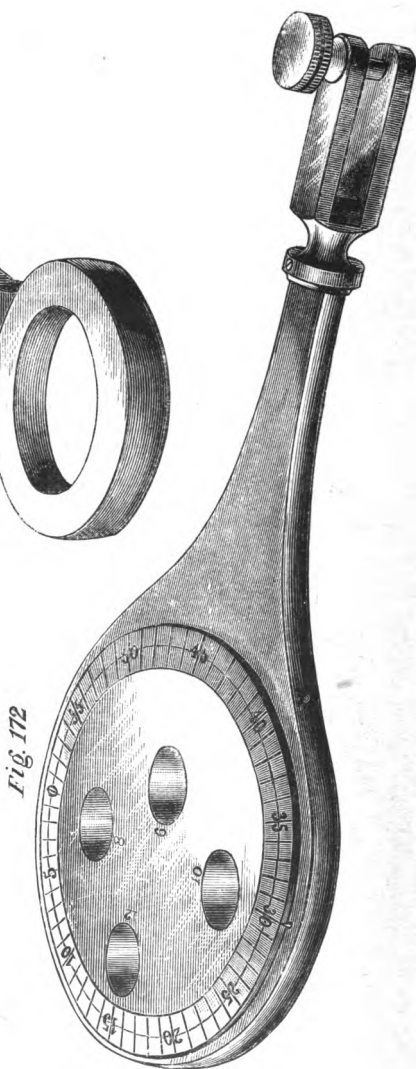

Fig. 172

At the opposite extremity of this arm a movable joint is arranged, the end being turned down and the latter fitted to it; this is retained in its place by the point of a small screw fitting in a groove turned in the pin. The joint has an open slot, into which the arm with the holes passes freely, being connected by a milled head screw with a plain part fitting the hole.

When adjusting the instrument for use, the following directions should be carried out. The short arm is placed on the dividing chuck and fixed by the circular nut, the long arm is then attached to the double arbor with a wheel in front of it, which must be selected to suit the work. For example, say the 120 wheel, the aperture in which must be filled up with the metal bush, and both it and the arm fixed by the nut and washer; the two arms are then connected by placing the pin through the hole that may be selected; the radial arm is then lowered to gear the 120 wheel with that on the slide-rest screw or socket, according to the manner in which the apparatus is fitted.

Upon turning the handle of the slide-rest, it will be seen that the mandrel performs a backward and forward motion, while the tool or cutter in the slide-rest travels laterally the necessary length of the work to be decorated, when it is arrested by a fluting-stop on each side.

The partial rotation of the mandrel in either direction, combined with the lateral traverse of the tool in the slide-rest, produces waved or undulated lines, which are varied by the alteration of the train of wheels; and again, by the difference in the fixture of the two arms in relation one to the other, by the holes, which are figured 1 to 11, the latter denotement being nearest the axis of the mandrel.

When the arm is placed on the arbor by the hole A, which has the smallest amount of eccentricity, and the second arm attached to it by hole 1, the least height of wave is the result, while with the eccentricity B on the arbor, and hole 11 employed, the greatest is obtained, the length of the wave being entirely governed by the wheels used in the train, the effect of the curve produced is also much influenced by the diameter of the material upon which it is cut. It will be useful to many amateurs to give a few of the different wheels that are available, and more generally employed to effect waves of given lengths:—For one of $\frac{2}{10}$, 18 on slide-rest with 36 on arbor; for $\frac{3}{10}$, 16 and 48; $\frac{4}{10}$, 15 and 60; $\frac{6}{10}$, 16 and 96; $\frac{8}{10}$, 15 and 120, etc., the smaller wheel being always placed on the slide-rest screw or socket, as before mentioned.

To change the arm attached to the arbor from one eccentricity to the other, during the progress of the

work, produces some very beautiful results, as the waved lines are cut in the reverse direction; but, at the same time, it is perhaps the most difficult operation to perform accurately, in consequence of the slide-rest screw requiring to remain without the least movement, while the eccentricity of the arm is adjusted. It will be seen that the face of the bush is divided at every quadrant, thus: ·|· | |· ×.

If the eccentricity A is fixed to the arbor with ·|· opposite the indicator, the wave will begin at the opposite side to what it will if the bush is turned round until the mark | be in the same position; but if the arm is fixed to the arbor by eccentricity B, this will be reversed, in consequence of the two eccentricities being on the opposite sides of the centre of the bush.

The relative positions of the various waves following each other round a cylinder or on a surface, are determined by the movement of the dividing chuck, in a similar manner to that in which numerous strands are cut with the spiral apparatus.

Fig. 172 illustrates a considerable improvement in the reciprocator, by which its capabilities are greatly increased; the metal bush on which the arm works is enlarged to 3 in. in diameter, and through it four holes are bored to fit the arbor, in the same

way as those in Fig. 171 ; but these, it will be seen, have their eccentricities extended to six, eight, ten, and twelve-tenths, by which the partial rotation of the mandrel is increased in each direction. But, so far, the only difference resulting from this is, the increased depth of the wave ; but the inventor of this improvement (Mr. Ashton) desired to create at the same time a greater length, in combination with the depth, which produces such extremely graceful curves, and, in order to effect this, it is essential that the lateral movement of the tool should be increased in equal, or even extended ratio, with the eccentricity. For this movement it is necessary to employ a second pair of wheels, which, in the instance of the spiral apparatus being fitted to the front of the lathe-head, are made to operate in an extra arm fitted across the end of the slide-rest, with the power of adjustment to suit different sized wheels ; but, when the spiral apparatus is fitted on the improved plan, the same result is obtained by employing the extra arbor (Fig. 169B). This is much to be recommended for the purpose, and disposes of the extra arm on the slide-rest.

Before entering upon the details of the manipulation of the apparatus contained in the preceding pages, it will be an advantage to have a table of the various wheels required to produce certain screws and

twists. The following is considered the most suitable for the purpose, and will be readily understood—the words mandrel, screw, and pitch signify the manner in which the wheels are geared, and the screw they produce:—

TABLE OF PITCHES DERIVED FROM SINGLE GEARING.

MANDREL—144.			MANDREL—120.			MANDREL—96.		
SCREW.		PITCH.	SCREW.		PITCH.	SCREW.		PITCH.
120	...	8.33	144	...	12.0	144	...	15.0
96	...	6.66	96	...	8.0	120	...	12.5
72	...	5.0	72	...	6.0	72	...	7.5
60	...	4.166	60	...	5.0	60	...	6.25
53	...	3.68	53	...	4.416	53	...	5.52
50	...	3.472	50	...	4.166	50	...	5.208
48	...	3.33	48	...	4.0	48	...	5.0
36	...	2.5	36	...	3.0	36	...	3.75
24	...	1.66	24	...	2.0	24	...	2.5
20	...	1.388	20	...	1.66	20	...	2.0833
18	...	1.25	18	...	1.5	18	...	1.075
16	...	1.11	16	...	1.33	16	...	1.66
15	...	1.0416	15	...	1.25	15	...	1.5625

MANDREL—72.			MANDREL—60.			MANDREL—53.		
SCREW.		PITCH.	SCREW.		PITCH.	SCREW.		PITCH.
144	...	20.0	144	...	24.0	144	...	27.16
120	...	16.66	120	...	20.0	120	...	22.64
96	...	13.33	96	...	16.0	96	...	18.11
60	...	8.33	72	...	12.0	72	...	13.58
53	...	7.361	53	...	8.833	60	...	11.32
50	...	6.944	50	...	8.33	50	...	9.433
48	...	6.66	48	...	8.0	48	...	9.056
36	...	5.0	36	...	6.0	36	...	6.792
24	...	3.33	24	...	4.0	24	...	4.528
20	...	2.77	20	...	3.33	20	...	3.773
18	...	2.5	18	...	3.0	18	...	3.396
16	...	2.22	16	...	2.66	16	...	3.088
15	...	2.0833	15	...	2.5	15	...	2.83

TABLE OF PITCHES DERIVED FROM SINGLE GEARING—
continued.

MANDREL—50.		MANDREL—48.		MANDREL—36.	
SCREW.	PITCH.	SCREW.	PITCH.	SCREW.	PITCH.
144	... 28·8	144	... 30·0	144	... 40·0
120	... 24·0	120	... 25·0	120	... 33·33
96	... 19·2	96	... 20·0	96	... 26·66
72	... 14·4	72	... 15·0	72	... 20·0
60	... 12·0	60	... 12·5	60	... 16·66
53	... 10·6	53	... 11·04	53	... 14·72
48	... 9·6	50	... 10·417	50	... 13·88
36	... 7·2	36	... 7·5	48	... 13·33
24	... 4·8	24	... 5·0	24	... 6·66
20	... 4·0	20	... 4·166	20	... 5·55
18	... 3·6	18	... 3·6	18	... 5·0
16	... 3·2	16	... 3·33	16	... 4·44
15	... 3·0	15	... 3·125	15	... 4·166

This table, it will be seen, bears no reference to the double gearing, which employs four wheels instead of two. It is, therefore, necessary to indicate this by a second table, which is practically the most useful in following the art of ornamental turning, as it is the longer twists that are generally used, and are the most decorative. The expressions in this case bear the same reference to the arrangement of the wheels as in the previous table, the double arbor being always used in place of the single one. When the apparatus is fitted to the back of the lathe-head, the reference to the screw bears the same relation to the socket, which has a corresponding influence, and it is connected to the slide-rest by the universal point.

TABLE OF PITCHES OBTAINED BY DOUBLE GEARING.

MANDREL.	ARBOR.	SCREW.	PITCH.	MANDREL.	ARBOR.	SCREW.	PITCH.
144	24			144	36		
	60	72	0.5		120	16	3.0
144	15			144	15		
	30	48	0.6		60	18	3.2
144	72			144	15		
	60	16	0.75		60	16	3.6
144	15			144	30		
	30	36	0.8		120	15	3.48
144	24			144	24		
	72	48	0.9		120	18	4.0
144	36			144	24		
	60	24	1.0		120	16	4.5
144	15			144	24		
	60	48	1.20		120	15	4.8
144	16			144	20		
	17	48	1.35		120	16	5.4
144	72			144	20		
	120	16	1.5		120	15	5.76
144	15			144	18		
	60	36	1.6		120	16	6.0
144	15			144	18		
	30	16	1.8		120	15	6.4
144	36			144	16		
	120	24	2.0		120	15	7.2
144	16						
	60	20	2.7				

CHAPTER V.

MANIPULATION OF THE SPIRAL APPARATUS.

THIS apparatus, although capable of producing screws of various pitches, from more than fifty threads in the inch to one complete turn in 7 in., is seldom employed for the purpose of cutting fine threads to be used as screws, and it differs from the slide and screw-cutting lathe only in the manner in which it is employed, the principle of connecting the guide-screw to the mandrel by a train of wheels being maintained.

As it is now to be considered, the mandrel is connected with the main screw of the slide-rest, and as thus arranged, it is in theory exactly the same as the slide-lathe, but is more suitable for ornamental turning, and the production of spirals of long pitches, which are generally known as Elizabethan twists. By reference to the illustration, Fig. 168A, it will be seen that to make the necessary connection between the mandrel and slide-rest, a wheel is placed on the dividing chuck, and gears into another on the double arbor, a larger wheel on the same gearing to one on the end of the

main screw of the slide-rest; a great number of different pitches may be cut with a train of three wheels only, geared in one plane, in which case the intermediate wheel bears no influence over the screw produced, but is simply a means of communicating motion from the wheel on the chuck to that on the slide-rest; the screw or pitch produced being dependent upon the multiplication or division of the main screw of the slide-rest, by the fraction given in the number of teeth in the two wheels—that on the chuck and on the slide-rest screw.

It will be seen at once that should two wheels only be used, the slide-rest having a right-hand screw, the twist produced will be a left-hand one, caused by the two wheels turning in opposite direction, therefore the intermediate wheel is necessary to the production of a reverse direction, as it guides the wheel on the mandrel and that on the screw of the slide-rest in the same direction, the result being a right-hand twist.

Spirals of both characters, however, are largely used in the practice of ornamental turning; and when it is necessary to change the direction from one to the other, the intermediate arbor with the 30 wheel is interposed between the wheel on the chuck and that on the arbor, and this, it may be repeated, does not alter the pitch, but simply changes the direction of the traverse of the slide, and in the case of large diameters,

also facilitates the movement of the slide-rest further from the axis of the mandrel, which is often necessary. At times, however, even a greater range is required, in which case a wheel of larger size is placed upon the single arbor, and takes the place of that referred to. This latter arrangement is seldom required, from the fact that double gearing is mostly used for ornamental purposes, as the longer twists are much preferred, and the most suitable for such work.

Double gearing is again illustrated by the engraving, Fig. 169, which shows the apparatus as now fitted on the new principle, at the rear of the headstock; it employs four wheels, as shown in Table 2; and, as seen in the engraving, the wheels are 144 on the dividing chuck, gearing to a pinion of 16 on the double arbor, a wheel of 120 teeth being on the same, which gears into a pinion of 15 on the socket, which is the same as when placed on the slide-rest screw; if the apparatus is fitted to the front, as in Fig. 168A, it will be observed, by reference to Table 2, that these wheels produce a twist of 7·2. Spirals consisting of more than two turns in 1 in. always necessitate the use of the double arbor, and any spiral beyond one turn in 7 in. involves the use of a third pair of wheels, which are usually mounted on the surface spiral apparatus, and connected by a pair of round-edged wheels of 30 and 60 teeth; but when the apparatus is fitted at the



1

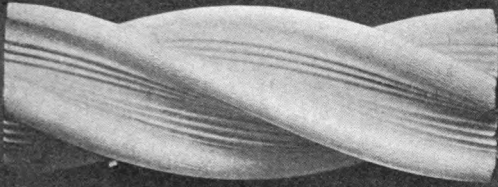

2

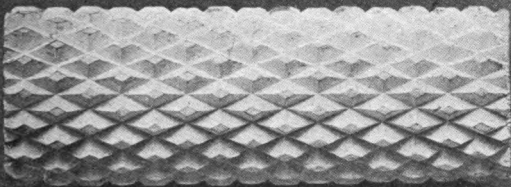

3

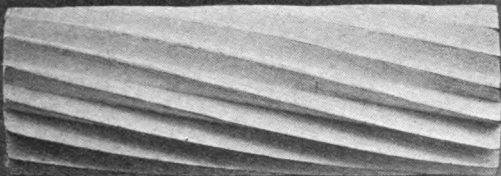

4



5

4020766

back of the lathe-head, the introduction of the double arbor, Fig. 170A, renders the surface spiral apparatus unnecessary for this purpose.

As seen by the engraving, the third pair of wheels is fitted on a steel arbor, which revolves in a socket, fitted to slide in a metal frame, which is fixed to the boss on the lower arm that carries the connecting-rod. The two extra wheels thus placed at the end of the train have the effect of producing a twist twice as long as that obtained without their addition, and as it can be taken off and refixed without delay, it forms a most important improvement to the apparatus. Spirals used in ornamental turning are generally of a multiple nature, such, for instance, as 2, 4, 6, 8, or any other number of grooves or strands being cut round the cylinder or form that is being ornamented, and it is for this purpose that the dividing chuck is employed; the dial-plate on the pulley cannot be used, from the fact that it is always rotating during the process of cutting the work. The height of the centre of the tool must also claim great attention from the operator; the slightest deviation from accuracy in this respect will entirely alter the result of the pattern produced, and if not adjusted precisely to the axis of the mandrel, more material will be removed from one side than the other.

The tool should always be carried through the cut

in one direction, it does not matter in which ; but as a rule a right-hand twist is cut from right to left, and a left-hand from left to right. The way in which the tool is made to revolve must depend somewhat upon the grain of the material to be cut ; sometimes it will cut more smoothly one way than the other. In all such spirals as those illustrated in Plate 10, the apparatus is worked by the winch-handle on the slide-rest screw, the driving-band to the pulley being of course removed. The necessity for always making the cut in the same direction is caused by the unavoidable back-lash in each of the several wheels when geared, and it will be evident that when the handle is turned the freedom between the wheels will allow the tool to move laterally before the work begins to rotate, thus causing it to cut more on one side than the other ; this, however, may not be fatal to the work, and, if the cut is carried through in both directions with a step-drill, the result will be, that the recess so cut is made wider than the diameter of the drill, and, provided the strand is cut right through at each end, it will not at times be a disadvantage, but where the spirals terminate within the cylinder at each end, through the traverse being arrested by the fluting-stops, every successive cut must be taken in the one direction only, otherwise the circular ends will be distorted.

In such spirals as Fig. 4, Plate 10, where the universal cutter is used, with a double-angle tool, the cut can only be made in the one direction, for the reason, that if the cut is increased in width, the figure of the tool would be lost, and a space left at the bottom, instead of the actual shape of the tool.

When the universal cutter is thus employed, it is necessary that the tool should be set to an angle, so that the plane of revolution will agree with the pitch of the screw or spiral it is desired to cut. The amount of angle required to be given to the tool is easily decided by trial, as it will be seen when a fine cut is first taken if it is correct; the angles, however, which are given for the following examples will be sufficient to direct the attention in this respect. When a variety of cutters is used, the instrument must be retained at the same angle throughout the work, and one important point is to always set the tool back to the same radius, should it have to be removed for sharpening; this is decided in the same way as explained with regard to this instrument when used for the pattern illustrated on Plate 3.

The production of spirals by this apparatus may be extended to a very large degree, and the variety of patterns to be so turned is practically unlimited. A very useful and decorative style is found in hollow spirals, which may be filled with material of a different

substance and colour. An ivory exterior, with its strands twisting gracefully round a blackwood interior, forms a very elegant combination.

A further development is derived from an ivory cylinder being bored out to a tube; it is then carefully fitted to a boxwood plug and cut through with a long twist; a second ivory tube is then fitted accurately to it. This again is fitted on a plug and cut to the same pitch, but in the reverse direction, the result being that two spirals in opposite directions are combined.

Spirals may also be cut with a compound twist, that is, one within the other, leaving a solid pillar through the centre. This form is illustrated by Plate 11, for the privilege of publishing which the author is indebted to Captain R. Pudsey Dawson, who has made this particular style of turning a considerable study. The settings for this will be explained as the subject is approached.

To adjust the spiral apparatus for such work as the examples contained in Plate 10, the radial arm is first placed in the circular groove at the back of the lathe-head; and it may be here mentioned that all references to the various adjustments will point to it as arranged in this way. The radial arm fixed, the wheel of 144 teeth is placed on the dividing chuck and fixed by its circular nut and washer; the double arbor is then placed in the oblong slot, and a pinion of 16 teeth,

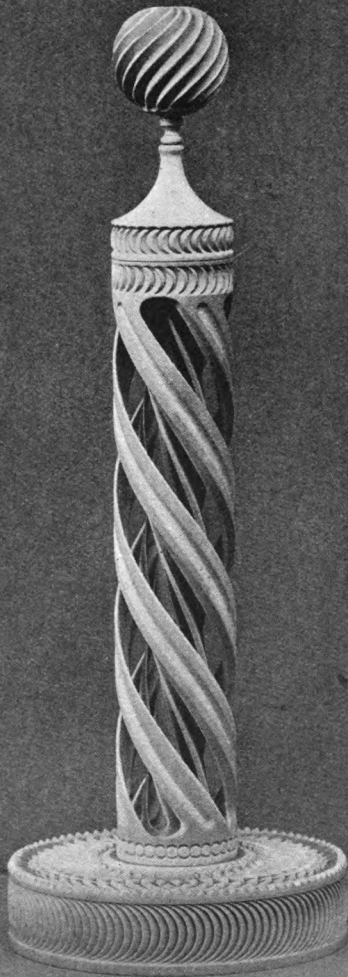

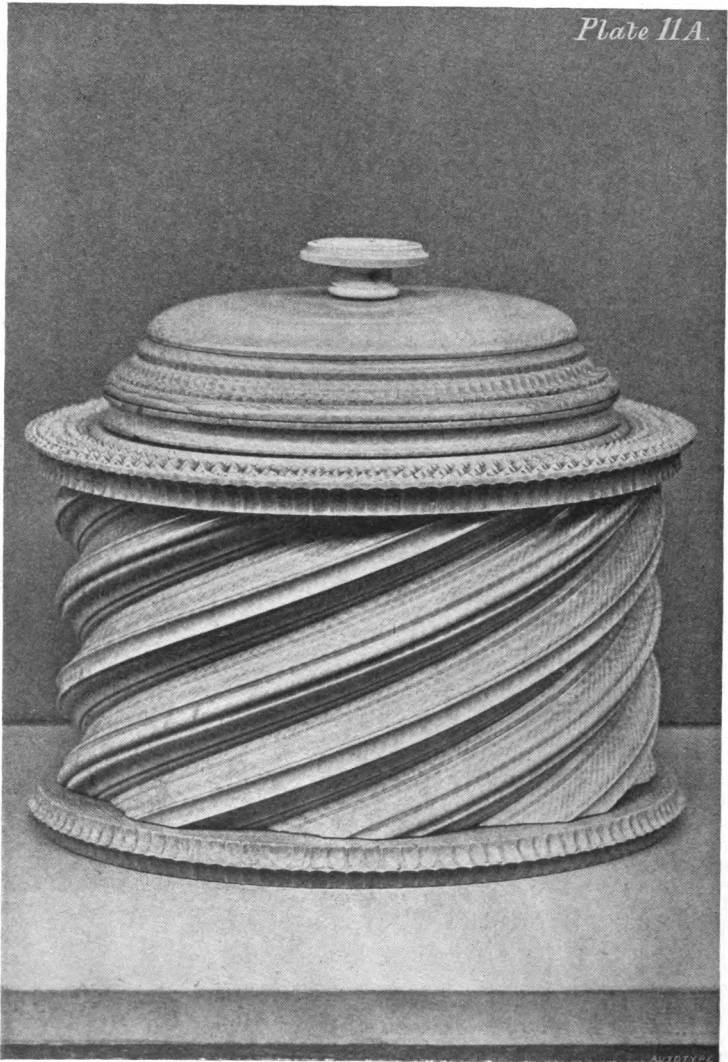

with a wheel of 120 teeth attached in front of it; the arbor is then moved in the slot till the pinion of 16 teeth gears with the 144 on the chuck; and they should be so placed as to work quite freely, to avoid any likelihood of an irregular motion; a pinion of 15 teeth is then fixed to the socket through which the connecting-rod passes, and the radial arm lowered till the 120 wheel gears with it. This combination, as before stated, gives a twist of one turn in 7 in. approximately. The engraving, Fig. 169, shows the way in which this is arranged. The connection is then made to the slide-rest by the rod being moved laterally till the socket of the universal joint will pass on to the end of the main screw, to which it is fixed. In this way the apparatus was arranged to cut Fig. 1, Plate 10, the material being first turned to a cylinder; the drilling instrument is then placed in the tool-box of the slide-rest, having in it a bold step-drill, the dividing chuck set at 96 on the worm-wheel, and the cut made from the popit-head towards the chuck. The worm-wheel of the chuck is then moved twelve divisions for each consecutive cut. This being a deeply cut pattern, it requires about three separate cuts, and for a finishing one, the drill should be taken out and carefully sharpened. Although a very simple example, it is a most effective style of ornamentation, and one that may be usefully employed for a variety of work.

For Fig. 2 the same wheels were employed, the universal cutter (Fig. 122) being used instead of the drilling instrument; and in order that the tool should follow the same plane as the twist, the cutter was set over to the right 30° ; a round-nosed tool, $\frac{1}{100}$ in. wide, was used to excavate the recess in the first place. The dividing chuck in this case is adjusted consecutively to 96, 24, 48, and 72, thus leaving four strands. Having removed as much of the superfluous material as desired, a square-end tool takes the place of the round-nosed one, by which the bottom of the recess is made flat instead of concave. The drilling instrument is then used in place of the universal cutter, and in exactly the same way as for Fig. 1; the universal cutter is then again employed to round the top of the strand, a bead-tool replacing that previously used; the angle of the instrument being unchanged.

Fig. 3 represents the difference in effect obtained by using the reversing arbor with a 30 wheel on it. The material was first turned to a true cylinder, the same train of wheels arranged, and the universal cutter, with a double-angle tool of 50° , set to the same angle of 30° for the right-hand twist, the dividing chuck set at 96, and a cut made at every six. The penetration of the tool is governed by the precise figure required. Having cut all round in this way, the radial arm is raised without moving the wheel on

the socket, the double arbor moved away from the 144 wheel, and the reversing arbor interposed; the arm is then lowered to again gear the 120 wheel with the 15 on the socket. The universal cutter is set over to the other side 30° , and the face of the tool reversed; the cuts are then made from left to right, or in the opposite direction to those previously cut, the result being as seen, a series of diamond-shaped facets.

The succeeding figure affords an opportunity of illustrating the advantage derived by using the extra arbor (Fig. 169B), which is for the purpose of making the twist or spirals of an increased length; the most that can be achieved with the wheels as already described, is one turn in 7 in. approximately; with the extra arbor the twist can be doubled, and by replacing the 30 wheel by one of 15, a still further elongation results. There is a very great advantage in being able to attain this end, as the extra length of twist gives a very beautiful appearance to the work.

Fig. 4 was cut with the following arrangement: the wheels being 144, gearing to 16 on double arbor, the 120 on same gearing to a 30 on the extra arbor, while the 60 on the same spindle is geared to the 15 on the socket. This combination gives a twist of about one turn in 15 in., the universal cutter is set over to 15° on the right, and the cut made from right to left with a double-angle tool of 50° . The wheels thus arranged

are even in number, and cause the spiral to be left-hand. To obviate this, the reversing arbor, with the 30 wheel, is interposed between the 144 on chuck and the 16 on the double arbor, thereby reversing the direction, with the result seen in Fig. 4.

Fig. 5 shows the result of combining the spiral apparatus with the ellipse chuck, from which very beautiful results are obtained. That now illustrated is quite a simple example, but serves to establish the fact that the two can be combined.

Plate 11 represents a distinct style of spiral turning. It will be seen that the stem or pillar has two series of spiral strands, one inside the other, but, at the same time, cut from the solid ivory. This may be termed compound spiral turning, and is now much practised by amateur turners. The length of the specimen under notice is 5 in., and the diameter $1\frac{1}{8}$ in.; the wheels employed in the train to produce the twist are, 124 on the chuck, 20 and 120 on the double arbor, and 16 on the socket.

The ivory for such a subject should be carefully selected, with the grain as straight as possible; it is then chucked in a wood or metal chuck, preferably the latter for such a purpose, and turned to a true cylinder. If the apparatus is fitted to the front of the lathe-head, the ivory must be turned true when the chuck holding it is placed on the spiral dividing chuck; the necessity

for this affords a further opportunity of pointing out the advantage of the whole of the apparatus being fitted to the back, in which case the work is turned on the mandrel-nose, the same as for any ordinary work, thus saving the unnecessary length of the chuck.

It must be assumed that the apparatus is fitted on the improved plan, therefore the work is turned to a perfectly true cylinder on the mandrel-nose, and then highly polished. A round-nosed fluting-drill, in size suitable to the space required between the strands of the spirals, is selected. The slide-rest must now be raised above the centre by the elevating ring, till the thickness of the strand is determined. This done, take a deep cut at 96, 24, 48, 72. It is an advantage to raise the point of the drill slightly, by a thin piece of packing under the front of the stem in the tool-box; this enables the drill to cut through the ivory with greater facility. Should it be desired to ornament the exterior of the strands, it must be done before the drill is carried completely through, because when the strands are released, they are too delicate to admit of its being done, even to the extent of the plain flute seen in the illustration, as the solid material which supports them has been removed by the drill, and the latter, prior to passing through, should be keenly sharpened. This process having been repeated four consecutive times, the first series of spirals is finished.

The solid cylinder left in the centre by the cutting of the first series must now be operated upon in a similar way. Having selected a small drill suitable to the diameter of the cylinder, the slide-rest is lowered till the point of the drill is exactly between the strands first cut. This is more accurately adjusted by means of the tangent-wheel of the dividing chuck; and now that the ratchet-wheel is obsolete, there is no necessity for releasing and resetting the radial arm to assist in the adjustment. When thus arranged, it is only to proceed as before, the result being a small cylinder left within the second series of strands. The drill should be driven at a quick and regular speed, and the lateral traverse of the slide be as even as possible; it is far better to use a series of different sized drills to follow each other. Work of this character, but of greater length, will require the aid of a slender guide to support it as the tool traverses, but with care 6-in. lengths may be safely executed.

CHAPTER VI.

THE SPIRAL APPARATUS AND ELLIPSE CHUCK IN COMBINATION.

PLATE 11A illustrates a further application of the spiral apparatus, used in combination with the ellipse chuck, and is one of the great advantages derived from the present arrangement of the apparatus, by which varied and beautiful work can be displayed. The body of the casket was turned from a large hollow piece of a tusk of ivory, the sliding-ring of the chuck being set out to suit its proportions, without waste; it was then turned out inside, and afterwards chucked on a boxwood plug its entire length, well fitted, and glued.

The first process is to turn it to a perfectly true elliptic cylinder; a large round-nosed drill is then used to excavate a considerable depth before the figure is attempted; the wheels used are those which produce a long twist, viz. 144, 16, 120, and 15. The ellipse chuck is set vertically, the drill accurately to the centre of the lathe axis, the first cut made at 96 of the

dividing-wheel, and repeated at every 12, by which eight consecutive flutes result.

An ogee moulding-drill now replaces the routing-drill, to shape the figure on each side of the separate strands; these cut, a small moulding-drill is carried in deeper at the bottom of the recess. To cut cleanly a depth similar to this example, requires a number of cuts, and the tool to be sharpened many times; in all such work, the drill should be most carefully looked to for the finishing cut.

The eight moulded strands being finished so far, the top of each alternate one is cut to a bead, and for this purpose the universal cutter (Fig. 122), with an astragal bead-tool $\frac{1}{100}$ in. wide, is employed, and the instrument set to an angle of 30° ; when the four strands of this character are cut, the tool is changed for a round-nosed one, with which the four intermediate mouldings are cut. Deep and bold cutting of this nature may be ultimately polished with a soft lamb's-wool buff running at a high speed, which gives a beautiful finish to it.

The base and top are separate pieces, taken from a tusk of large dimensions; the former is cut out each side with a round-nosed drill; the latter has a deep eccentric pattern cut on the surface, and a hollow underneath to correspond with the bottom. The lid, which is hinged at the back, is composed of a series of

moulded and plain parts, the finial being an elliptic knob. Caskets of this stamp should be lined inside with satin; it is a great improvement, and at times assists in hiding from view a bad place in the material, to remove which would reduce it to a size unsuitable for its purpose.

CHAPTER VII.

EXAMPLES OF SURFACE SPIRALS AND RECIPROGATOR.

PLATE 12 illustrates a few patterns produced on surfaces by interposing the apparatus (Fig. 170), by which the motion is conducted to the slide-rest when set transversely across the lathe-bed; and if the spiral apparatus is fitted to the front, it is also necessary, as already intimated, to the application of it to cut work upon cones; but with the apparatus fitted at the back of the lathe, illustrated in Fig. 169, this is avoided, as the universal joint allows all such work to be done better without it. Curved surfaces are also to be decorated with the slide-rest in this position, when the curvilinear apparatus is used, and by this very beautiful results are obtained; the revolving instruments are all applicable to this as well as cylindrical forms. The strands may be also cut in either, or both directions, and, when crossed and cut with a step-drill, a series of gradually decreasing pyramidal points renders the effect most decorative and interesting. To attempt to describe even a limited number of results to be obtained would

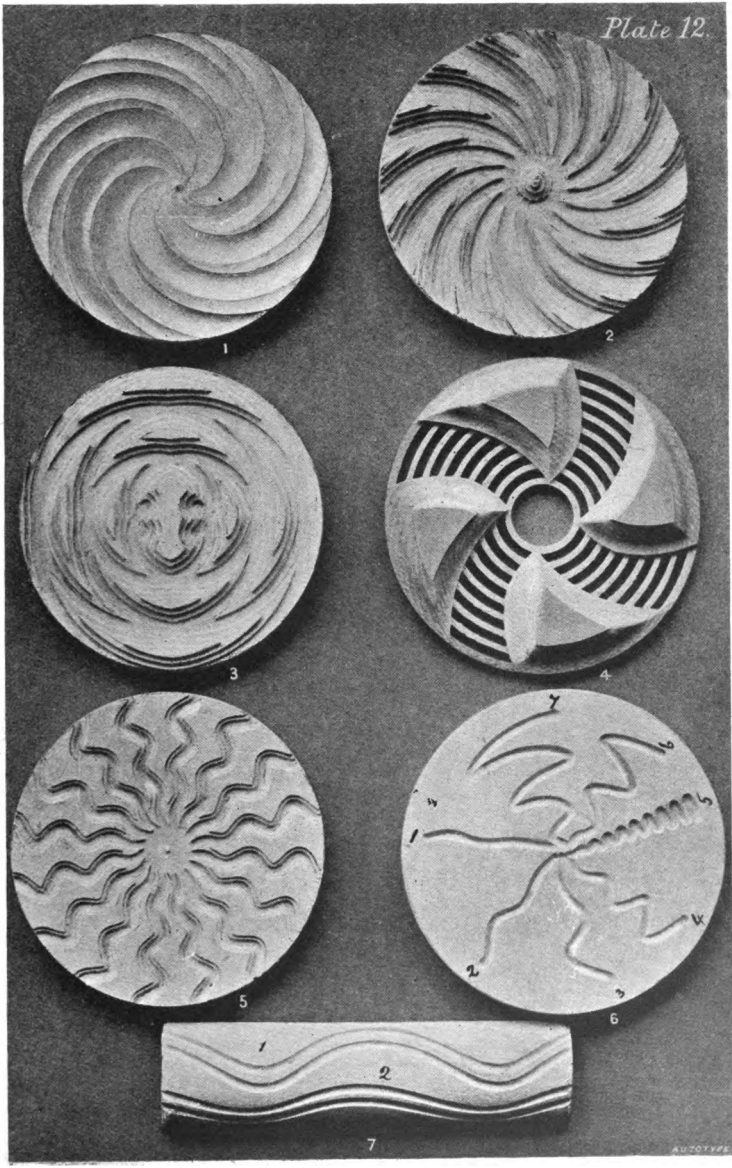

occupy a book in itself, but those now shown in the plates will serve to explain the way in which the apparatus is applied, and to demonstrate the more simple results, which will lead to far greater attainments, and, it is needless to say, the variations may be carried on *ad infinitum*.

Fig. 1 is quite a primary application of the apparatus. The wheels employed were 144 on dividing chuck gearing, into 16 on double arbor, 120 on the same, running into 15 on the socket, thus producing the twist. The surface spiral apparatus (Fig. 170) is then placed so that the end of the socket is connected to the universal joint; the mitre-wheel with 30 teeth is fixed on the end of the sliding-rod and geared to the 60 wheel of the same form, which is fixed to the end of the slide-rest screw.

The universal cutter (Fig. 122) was then placed in the tool-box of the slide-rest, and turned to 90° on the right, to operate as a vertical cutter, and a round-nosed tool placed at a radius of $\frac{6}{10}$, the dividing-wheel of chuck set to 96, and a cut made at every 12, the penetration being about $\frac{1}{20}$. Having cut thus eight times, the wheel of the chuck is moved six divisions, the radius of the tool reduced $\frac{2}{10}$, and the depth of cut decreased, so that the second series of cuts takes place between those already executed; the fluting-stop is fixed on the right side of the tool-box to arrest the

tool at the centre, the cuts being made from the margin to that point.

Fig. 2 is cut with a step-drill in place of the vertical cutter, and being, as will be observed, of a longer twist, the extra arbor (Fig. 169B) is employed; therefore the train of wheels is as follows: 144 on chuck, 120 and 16 on double arbor, the 144 gearing into the 18, the 120 into the 30 on the extra arbor, the 60, which is on the same spindle, gearing to the 15 on the socket. The mitre-wheels are the same in every respect. The step-drill is then inserted to the depth required, and arrested short of the centre by the fluting-stop, so that at that point the figure is represented by a pyramid, resulting from the shape of the drill. In this example there are sixteen cuts, every sixth division of the wheel being employed, the gradual diminution of the strands towards the decreasing diameter being very effective.

Fig. 3 represents the twist or strands cut in both directions, the same drill being used. This particular result would lead any one to suppose that it was produced by other means, as the crossing of the spirals at various points so destroys the continuous line that the effect is quite altered; it may also be varied in many ways. The wheels to give this result are very different to those employed for the two previous subjects; the extra arbor (Fig. 169B) is removed, and those used are 144 on the chuck, gearing to 18 on arbor, 120 on

the same, gearing to 72 on the socket, in place of the 15.

The right-hand spiral is first cut from the margin towards the centre, and arrested about $\frac{1}{10}$ on the left side by the fluting-stop; the wheel of the chuck is then moved from 96 to 48, which is the opposite, or half of the entire revolution; the second cut is then made. The slide-rest is returned to the margin, the radial arm raised, and the intermediate or reversing arbor introduced between the 144 and 18; the arm is then lowered to gear the 120 and 72, and the two cuts repeated in the opposite direction, for which the wheel on the chuck is set to 24 and 72 respectively. A very distinct figure is the result of this arrangement, and when worked out on large diameters the effect is much improved. All such work may be cut from the centre and stopped at the margin, if for any reason it is found preferable to do so, for which it is only necessary to place the second fluting-stop to operate on the opposite side of the tool-box. Particular attention must be given to the reduction in the loss of time caused by the freedom inherent to so many wheels in gear at the same time. The correct way to overcome this is, when the tool is returned to the starting-point, no matter in what direction it is (although from margin to centre is generally most suitable), it should be traversed past that point and returned to it, the number

of divisions on the micrometer necessary for the purpose being noted, and the division at which the reading line points when so returned will be the position at which the drill or cutter is to be inserted for each succeeding cut. When the terminal point is reached, care must be exercised that no portion of the return journey is commenced until the tool is withdrawn from the work.

Fig. 4 displays a still further advance in this class of surface spiral decoration; the train of wheels again differs, inasmuch as the extra arbor (Fig. 169B) is again employed to increase the length of the twist, the train consisting of the following wheels: 144 on the chuck to 18, 120 to 30 on the extra arbor, 60 on the same gearing to 15 on the socket, the connection to the slide-rest transversely being the same. The ivory is first chucked in a boxwood chuck and by plain turning carefully surfaced, then, with a shoot parting tool $\frac{5}{100}$ in. wide, a series of incisions is made, the first nearest the margin, and about the width of the tool from that point; the depth of the cut is arranged according to the substance of the material and the style of decoration desired. When the first incision is thus made, the stop-screw must be adjusted, and for each successive cut it must be carefully brought to precisely the same place by the guide-screw; the tool is then moved twice its own width, which will

be one turn of the main screw, and the second cut made; the same process is repeated throughout the distance required. The ultimate beauty of the work, when cut on the other side, depends entirely upon the accuracy of these incisions, and too much care cannot be exercised in the production of them.

The work must now be re-chucked, and, when preparing such a subject for this process, the periphery should be turned slightly taper to facilitate this object. A well-seasoned boxwood chuck is the best for the purpose; it should be turned out to fit the work as accurately as possible, and the bottom left perfectly flat and true; the work is then gently tapped into it, against the inner surface, until by the sound it is proved to touch it at every part. As a rule, all work held in a chuck of this kind should not touch the bottom of the chuck, but for this particular purpose it is necessary, as the work to be cut on the front must be absolutely true to that already executed, and the close contact of the two true surfaces is the safest means to adopt. Thus held, the material is turned to the desired thickness between the bottom of the recesses in the back, and the surface to remain uncut.

To cut the front, in this instance, a large round-nosed drill (Fig. 127) was first employed, and the superfluous material cleared away at every quadrant

of the wheel of the dividing chuck, thus—96, 24, 48, 72; a drill with a square end was then used to finish the surface, and to just expose the cuts in the back, but not deeper than is necessary for this, or the excellence of the work is destroyed. An ogee moulding tool with a fillet is then used to shape the projections that now stand on the top of a series of rings; the material having been removed to such an extent, the moulding-tool will not reach the figure, therefore the part to be shaped must be brought in contact with it by turning the tangent-screw of the dividing chuck sufficiently to obtain the necessary depth to complete the figure, when each side of the four projections may be finished. Before any alteration is made, the number of divisions that the wheel is moved from the original zero should be noticed, and the wheel then moved to exactly the corresponding number on the opposite side, so that the other side of the figure may be treated in the same way; the drill is then moved by the screw of the slide-rest to present it to the outer diameter, the same depth of course being maintained. When the drill is advanced, the work is slowly rotated by hand, or by the tangent-screw and worm-wheel of the segment apparatus; this completes the shaping of the projections left on the surface, and it will be seen that, from the combination of the spiral line and the circular one, the

points all mitre at different angles, but correctly, and render the effect pleasing for many purposes.

Fig. 5, Plate 12, illustrates the result of employing the reciprocator in connection with the spiral apparatus, as explained in the details of the instruments (Figs. 171 and 172). To produce the figure as seen, the reciprocator (Fig. 171) was placed on the double arbor by eccentricity B, the largest amount, a wheel of 120 in front of it, geared to one of 18 on the socket; the arm on the chuck was then fixed to that on the arbor by the first hole, and a step-drill used to cut the figure. The gradual tapering of the waved line gives very excellent results, and may be varied in a great number of ways.

Fig. 6 represents a few of the variations to be obtained, and the manner in which the different settings are arranged to produce the figures, as seen in the illustration. As there are seven distinct classes of wave on this one disc, they are numbered consecutively from 1 to 7.

No. 1 is produced by a train of wheels consisting of 144 on the double arbor, to which the reciprocator is also attached by its eccentricity A, the lesser amount; the 144 is geared to a 15 wheel on the socket, and the arm on the dividing chuck is fixed to that on the arbor by hole 1, that furthest from the chuck. The line is cut with a small round-nosed drill, and as they

are simple illustrations of the difference in the curve, resulting in each case from a re-arrangement of the apparatus, it is not necessary, in fact, it is preferable not, to use a figured drill. It will be seen that the result in this instance is a line with a slight wave, deeper, as in all work thus executed on the face, at the larger diameter, and gradually decreasing in depth towards the centre.

No. 2 differs, inasmuch as the wave is deeper; the same wheels were used, and the only change required is to attach the arm on the arbor by the eccentricity B, or the largest amount, which causes the mandrel to move a greater distance in its partial rotation; the wheels being the same as those for No. 1, the length of the wave is the same, but the extended movement of the mandrel increases the depth.

No. 3 again employs the same wheels and corresponding eccentricity, but the arms are joined by hole 8 on the short arm; this simple alteration again extends the rotation of the mandrel, and creates a still further depth of wave.

No. 4, which, it will be seen, has increased depth of wave, and decrease in length, by which the number of waves is multiplied in a corresponding distance, is obtained by the same eccentricity and the corresponding fixture of the two arms; but the wheels are both different—96 on the arbor gearing to 15 on the socket,

which lessens the proportional traverse of the slide to the semi-rotation of the mandrel.

No. 5, it will be observed, bears an extremely distinct appearance, which is the result of employing a wheel of 48 in the place of the 15, and attaching the arms by hole 1 on the short one, the eccentricity B being the same; thus a further increase in the number of waves is the result.

No. 6 is a further variety, and to effect this particular pattern the larger reciprocator, Fig. 172, takes the place of the smaller, being placed on the arbor by the hole which gives an eccentricity of $\frac{8}{10}$, the arm attached by hole 1, the wheels being 144 on arbor to 20 on socket, thus a similar number of waves in a corresponding given length, as No. 4, is the result, but of a considerably greater depth; and by removing the short arm and attaching it by hole 8 in the short arm, the effect is as seen in the waved line No. 7, which is of further increased depth only, and represents a figure, considerably altered in appearance, although of the same description. These few examples are sufficient to indicate the innumerable variations that may be made with comparatively simple alterations, and will also show clearly the manner in which the reciprocator is employed for figures to be produced on the surface. The motion is conducted to the slide-rest in each case by the mitre-wheel of 60 thereon, being geared to the

30 on the sliding-rod of the surface spiral apparatus; or the newly designed double joint (Fig. 170A) may be substituted.

We now come to the same instrument employed upon the cylinder, dispensing altogether with the intermediate connecting apparatus. The slide-rest in this case is set parallel with the lathe-bed, and connected by the universal joint in the same way as for spiral turning, and all the waved lines previously described, as executed upon the surface, may, with equal facility, be transferred to the cylinder.

The two examples seen on Fig. 7, and numbered 1 and 2, will suffice to establish this fact; and as more elegant curves are produced by extended eccentricity and quick traverse of tool laterally, the larger instrument (Fig. 172) was used in conjunction with the extra arbor (Fig. 169B), thus employing four wheels instead of two, so that the lateral traverse of the slide-rest is increased beyond what it is when only two are used.

To cut the line No. 1, Fig. 7, the eccentricity of $\frac{8}{10}$ is employed, the wheels being 144 on arbor geared to 30 on intermediate arbor, the 60 on latter being placed in gear with a 15 on the socket, and the arms attached by hole 8.

No. 2 of these examples is the result of the same wheels and eccentricity, but with the arms attached by hole 1 in the short arm; by which means the partial

rotation of the mandrel is decreased, and a longer wave is obtained. Decorations of this kind are most useful for such subjects as whip-handles, candlesticks, etc., and a large variety of ornaments. They may be cut in both directions by adjusting the work to the opposite side, as referred to in the description of the instruments.

CHAPTER VIII.

IVORY CANDELABRA.

THE preliminary proceedings for a subject of this kind will consist of a careful selection of the ivory, which should be matched in grain and colour as nearly as possible ; it is also advisable to have a rough sketch at hand, so that the proportion of the design may be more clearly and easily worked up. It has no doubt been observed by many turners that at times a vast deal of beautiful cutting is executed upon a piece of work entirely out of proportion, and thereby thrown away. Should the candelabra, Plate 13, be considered worthy of reproduction, the following details of its construction will, it is hoped, be of assistance in carrying it out.

The base is made from a piece of ivory $4\frac{1}{2}$ in. in diameter and $1\frac{3}{8}$ in. thick. This was first held in a universal chuck, and turned to a true circle inside, sufficient only to increase the inside of the hollow in the ivory to a circle, and by this it is again chucked on a boxwood plug, to which it is glued ; the latter is not absolutely necessary, as there is not a great deal of

work to be done to this part. The base is left $\frac{1}{2}$ in. thick; it is then reduced as far as the hollow, when it is again carried in square, and the front turned to an angle, the slide-rest for the latter purpose being set 30° .

Having shaped this part so far by following the design from the illustration, the slide-rest is returned to its original position parallel with the lathe-bed, and the universal cutter (Fig. 122) placed in it with a double-angle tool of 55° , the 120 division used, the tool penetrated at every hole, and deep enough to bring the points up sharp. The instrument is then set over to operate as a vertical cutter, using a tool (Fig. 109) which, it will be seen, admits of the cut being carried close up to the shoulder, which could not be effected with either of the other instruments, without extending the radius of the tool beyond what is required. The diameter of that part to be so ornamented is $3\frac{1}{2}$ in., and twenty-four consecutive cuts are made; the slide-rest is then placed at the same angle at which it turned the plain form, and a corresponding number of cuts made, only just sufficiently deep to bring the terminal points in a line with those previously cut on the edge. By using a very keenly sharpened tool, these parts may be brought up to great perfection, leaving nothing to be desired.

A shallow recess is made on the surface of this part to receive the ring, which is next fitted; this, it will be

seen, is also cut with the vertical cutter, but with twelve consecutive cuts only. The drill-spindle is then substituted for the universal cutter, and a bold step-drill employed, the index being set to the half of the number used to cut out the segments, so that the drill passes through its precise centre.

The stem or pillar upon which the branches are supported will form the next proceeding. This is made in two separate pieces, with an ornamented ring of ivory between them; the lower piece is $1\frac{3}{4}$ in. in diameter at the base, gradually tapering towards the top, the same gradation being conveyed to the upper portion; care must be exercised to ensure the gradual tapering of the whole column, allowing for the intervening connection; the base of the column is held to the foot by a steel pin $\frac{1}{4}$ in. in diameter, being firmly screwed into it with a nut and washer on the under side; the two parts of the shaft are also connected by a steel screw of the same size, the ring being kept central by a plain fitting.

To cut the twist, the spiral apparatus is employed; the train of wheels consisting of 144 on the dividing chuck, geared to the 18 on the double arbor, the 120 on the same gearing into a 20 on the socket; the universal cutter (Fig. 122), with a round-nosed tool $\frac{1}{100}$ in. wide, set out to a radius of $\frac{1}{10}$, and set to operate as a vertical cutter.

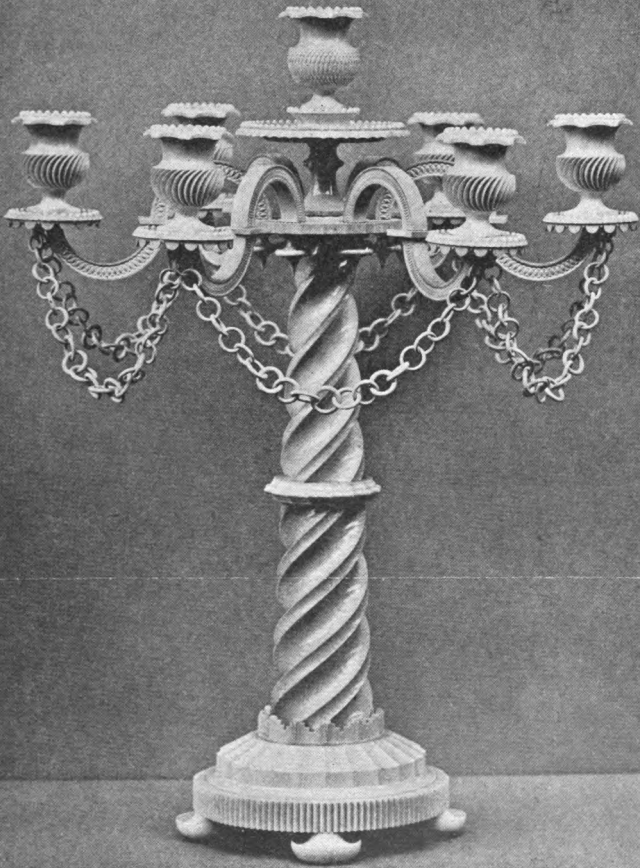

The work was held in the following way :—It being necessary to cut entirely through the length at each end, the hole tapped in the end was screwed to a corresponding thread on the chuck, the latter being turned down to the same diameter, so that the cutter passed clean through without fear of splintering or damaging the base ; in consequence of the face of the ivory being in close contact with the chuck, the opposite end is supported by the popit-head centre ; the dividing chuck set to zero, and a cut made at 96, 24, 48, 72, four cuts in all. The column now under notice was cut at one cut, to try the power of the new instrument (Fig. 122), and was left from the tool, by which the excellence of the improved instrument was at once established. Although the result of this proceeding was in every way successful, it is recommended that such work should be executed in two or three consecutive cuts.

Having cut all four segments, the radius of the tool is reduced to $\frac{4}{10}$, the dividing-wheel moved to 12, and the cut continued at 36, 60, 84, the tool penetrated to bring the edge up perfectly sharp. The lower part, thus cut, is removed, and the upper portion placed on the same screw, the diameter of the chuck being reduced to correspond with it ; to cut this the same process is adopted. And here again considerable care is necessary not to cut below the surface, or the general

tapering of the form will be destroyed, which will greatly mar the beauty of the work.

On the end of the upper portion a plain pin is left, to which is fitted the plate that holds the branches, and projecting beyond this is a screw that fits into the base of the tazza on the top, the foot of which holds all secure when finally put together. The outer edge of the ivory plate is cut out with the vertical cutter, the face has a deeply cut eccentric pattern, not seen in the illustration, and the six holes are drilled equidistantly to receive the branches.

The tazza is made in two pieces, the top being scalloped at the edge with a large quarter-hollow drill, a row of beads being cut to project above the surface, a similar effect being produced on the small projection at the centre, above which the socket to hold the centre candle is fixed. The branches to hold the sockets must next be made. These, it will be observed, are the result of rings which, when carefully finished, are cut in halves and connected in opposite directions. They are $2\frac{1}{8}$ in. in diameter externally, and $1\frac{1}{2}$ in. inside, turned in width to equal the substance remaining from the two diameters. The face of each is then ornamented on both sides with the eccentric cutter, each one differently. This is done after the plain part has been carefully polished.

The horizontal cutter (Fig. 118) is then employed,

with the spindle and saw to cut the rings precisely in the centre. The saw is carefully adjusted to the axis of the mandrel by the two set screws, and by the main screw of the rest it is passed across the face, by which process the rings are equally divided, and perfectly square and flat where it is cut, so that when reversed the two halves will fit together and be parallel one to the other. To fix them together, and hold them firmly when fixed, a steel pin, having a thin piece between the joints to break the plainness of it, is screwed into the centre, and forms a more appropriate finish. To cut the six squares all exactly alike, a piece of ivory should be turned to a cylinder the required diameter, and long enough for all; each piece is partly cut through, the vertical cutter is then used to produce the four concave sides, and, when this is done, they may be finally severed; being thus cut in one process, they are all made precisely alike, and in less time than if cut separately.

To attach the branches to the disc, which is fixed to the top of the column, a steel pin is also employed. This is firmly fixed in the centre of the square formed by the half of the ring, and the ivory nut which holds it has a plain part which fits the hole in the disc. This is less trouble than attaching a piece to the ring, and answers the same purpose. On the opposite end of the branch another steel pin is fixed to receive the

sockets that hold the candles; at the base of each socket a round disc of ivory, $1\frac{3}{4}$ in. in diameter, is fitted, the hole in the centre being only just large enough to fit over the steel screw; it has a scalloped edge, which is cut with a pointed bead-tool similar to Fig. 105, $\frac{2.5}{100}$ in. wide on the cutting points. For this operation the instrument is set so that the tool cuts horizontally; there are sixteen consecutive cuts, the intervening point being the result of what is left from the angles on the sides of the tool. These should all be cut on the same chuck, and the same settings used, and, when thus far finished, they can be re-chucked by the inside of that part previously cut; this must be carefully done, so that none of the points are broken. On the top a series of small beads, thirty-two in number, is cut with a bead-drill $\frac{1.2}{100}$ in. wide, and the edge again cut to the same number with a round-nosed tool. These discs form a foundation upon which the base of the socket or sconces rest, and add greatly to the elegance of the whole design.

The next proceeding will be to make the six holders for the candles, and the only difficulty that will be found, is the fact of their being all required precisely alike. The six pieces of ivory should be all cut off the same length; each one is then held in a universal or die chuck, and the hole to receive the candle bored or turned out, all being made exactly the same size,

in order that ultimately they may be worked up on the same chuck; the hole finished, the body and lip must be shaped and polished, the former only as far as the extremity of the concave curves is concerned; the top part is then cut out with the vertical cutter to eight concave curves, leaving about $\frac{1}{8}$ in. between each, to be cut with a drill; the face then has a series of twenty-four beads cut on it with a drill $\frac{1}{100}$ in. wide. Having carried out the same process on each one, they should be re-chucked by the hole, and, as before suggested, if they are identical in size, one chuck will suffice for them all; when reversed, the lower part of the vase must be shaped and polished.

To cut the pattern on the convex curve, the eccentric cutter is used with a single-angle left-side tool 60° , the slide-rest is set to an angle of 40° , and raised $\frac{1}{8}$ in. above the centre, so that the cut only takes effect on one side of the work. This particular class of work is illustrated also by Figs. 5 and 6, Plate 1; there are thirty-two cuts round this part, and, being cut deeply, it is, for such a purpose, a most effective result.

The base is then cut square with the eccentric cutter, having a round-nosed tool in it. The size, when finished, is $\frac{5}{8}$ in., therefore the diameter of the material must be left large enough at that part to admit of its being perfectly clean and sharp when reduced by the eccentric cutter to this size.

The centre sconce is made the same shape, but is cut on the convex curve rather differently, inasmuch as the slide-rest is adjusted to the precise height of the mandrel axis, and a double-angle tool used in place of the single-angle. The chains hanging from each arm complete the work, as illustrated. These are made in rings of different sizes, gradually tapering from the centre to the ends in each direction, and are put together by each alternate ring being split, which must be carefully done with the grain; they are then soaked in warm water, when they will open, and when dry the joint will remain quite close. They are attached to the arm by a small ivory pin with a head to it, screwed to the branch immediately under the disc.

Being strongly made, and each part firmly attached, it may be considered a useful as well as an ornamental specimen of turning, and the designs for such subjects may be carried out in a variety of ways. That now described may, at the same time, suggest many improvements for future operations, and assist amateurs in the development of this class of work.

CHAPTER IX.

THE SPHERICAL SLIDE-REST.

THE modern rest of this particular construction, with all its latest improvements, will be found illustrated by the engraving Fig. 173. . It is composed of four slides

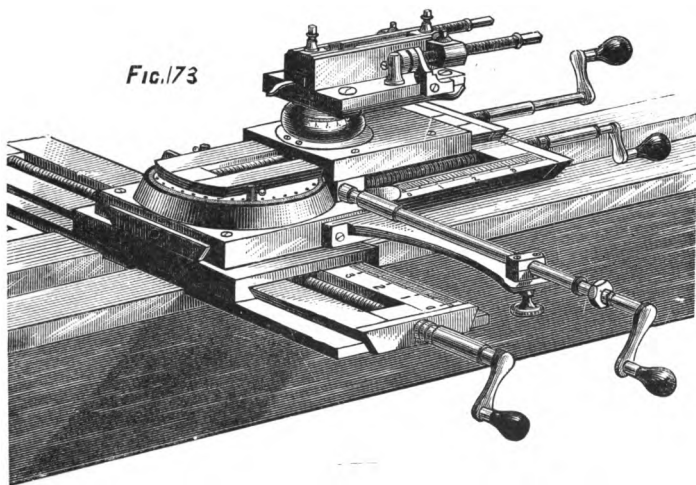

and one rotary movement; the two slides at the lower extremity working at right angles one to the other, below the circular movement, while the two upper slides are arranged to work above it.

The movable plate, which is fitted to the third slide, has a socket cast on it in the solid, to which the stem of the plate carrying the tool-box is fitted, and the same is clamped in any position by a screw passing through a steel ring which encircles the socket. In proceeding to manufacture such an instrument, the following details will, it is hoped, be found of some service.

Like all such tools, it should be commenced at the foundation, therefore the first or lower slide should be chucked carefully on a planing machine, face downward, and the tenon planed to fit freely in the interval of lathe-bed, the base being surfaced at the same time, where it rests on the bed.

It will be seen by reference to the engraving that this slide is made to extend on both sides of the lathe-bed, and proves of considerable service when the rest is used to turn and decorate large concave curves. At the end, overhanging the top board, that is, away from the operator, a projection is left on the under side, through which a long steel screw passes, and, when tightened, draws the tenon against the inside of the lathe-bed, thereby ensuring the rest being square to it. It is also provided with a holding-down bolt, with bow-handle and washer, to fix it firmly to the lathe-bed when in use.

The tenon and base being planed, the slide must be re-chucked on the machine, and the face and angles

planed perfectly true to it ; and here great care must be exercised, as much depends on its accuracy, so that when the screw is tightened to the bed and the tenon drawn against it, the slide will be at right angles. The plate which forms the slide is then got up to a perfect surface and the two side-bars fixed ; these are made of gun-metal, and held by three screws, the heads countersunk in the under side. One bar has also two steady-pins, the other is adjustable by two set-screws, which are screwed into the steel plate, their heads projecting so as to create a pressure upon the metal bar. When fitted thus far, the slides should be very carefully ground together with fine oilstone powder, but the greatest care must be taken to exclude emery powder of any description.

On the top of the plate, the second slide is fixed, having been first planed and surfaced. It is held firmly by four steel screws, with their heads also countersunk in the under side of the plate ; its position is such that one end is flush with the side of the first plate, the whole of the extension being on the right side, as seen in the engraving. In fixing this slide to the plate, one screw should be first put in, the slide then set perfectly true at a right angle to the lower one, when it will be in a parallel line with the bed, and when so set, the other three screws are fitted with greater facility. Having the slide thus fixed, a plate, similar to that on which

it is placed, is fitted to it, with gun-metal bars, in the same way as the lower one.

The rotary movement will be the next to engage attention. The worm-wheel is made of gun-metal, and has 120 teeth cut on its periphery, and is actuated by a steel tangent-screw, working in a frame of the same material; the frame is pivoted at one end, and is thrown in and out of gear by a steel cam and spring, the action being the same as applied to the ellipse and other chucks.

The top of the wheel is turned out at its centre to receive a large screw, with $\frac{3}{4}$ in. plain part and $1\frac{1}{4}$ in. diameter in the head; the screw is then accurately fitted to it, and screwed into the top plate of the second slide. This screw should be so fitted, that when it is forced tightly to the plate, the worm-wheel will revolve without too much freedom between the face of the plate and the head of the screw, and (as seen in the engraving) is on the left side when the slide is parallel to the lathe-bed. The worm-wheel is covered with a gun-metal ring, fitting closely round its periphery for the purpose of excluding dust and shavings; the frame into which the tangent-screw is fitted is also cut out to fit round the wheel for the same purpose. On the top of the worm-wheel, the third slide is fixed by one extremity, and held by four screws countersunk into the bottom of the wheel.

On this slide a strong gun-metal plate with a projection to form a socket is fitted, in the same way as those already described. The bars should then be removed, and the plate very carefully chucked by its lower surface, the socket then turned out to 1 in. in diameter to receive the stem of the fourth slide. When this aperture is turned out, a small air-hole should be drilled through the base, or a perfect fitting cannot be made; at the same time, the external part of the socket should be turned to receive a steel ring, through which the fixing-screw will pass, to hold the stem of the top slide in such positions as it may be required when in use.

The fourth and last slide is, to a very large extent, a copy of the ordinary tool-box of the ornamental slide-rest, being fitted up on a steel plate with a stem attached to it to fit into the hole already turned out in the socket of the plate on the third slide. This fitting is one in which particular care should be exercised, as it must fit accurately, or the pressure of the binding-screw will alter its truth in relation to the other slides. It may be well to again refer to the necessity for absolute truth in all the chuckings, as the least error in any one will eventually become a serious drawback when all the slides are finally put together. Nothing but extreme accuracy of workmanship will make such an instrument capable of working truly.

At present, it will be seen, there is no adjustment for the exact height of the tool. To effect this, the stem which fits into the socket has a screw through it, which raises or lowers the tool slide. This screw, the head of which is under the tool-box, is only accessible when the latter is withdrawn. This can very easily be done when any alteration in the height of centre is necessary. It will be seen that the steel ring which surrounds the socket has a divided scale on it. This is most useful in setting the tool round to any particular position that may be found necessary.

The slides being so far finished, the fitting of the main screws will form the next proceeding. These, like all such screws, are made with ten threads to the inch. The ends of the slides are carefully lined out and drilled, the front large enough to allow $\frac{7}{16}$ -in. screws to pass freely through, while the opposite ends are drilled to receive the point of the screws when turned down to the bottom of the threads. The front is also counter-sunk to receive the collar attached to the screw, which must be well fitted. Gun-metal plates are then fixed to the ends of the slides to hold the main screws in their places. On the end of each screw a gun-metal micrometer is fitted, divided into ten equal parts. These are first turned down, so that the slides will pass over them, and not made with milled heads. The latter are entirely a mistake, as they prevent the slide moving

as far as may be required. This is avoided when they are turned down, and each slide, it will be seen, has a divided scale on its surface, marked at each turn of the screw, that is, every tenth of an inch. This has been found of very considerable service.

Another improvement in this instrument is of such a simple character as to scarcely deserve the name, but, at the same time, it renders the tool considerably more serviceable. It is simply the addition of two extra holes, in which the screws that hold the nut of the third slide are placed. Its importance is clearly shown by the fact that work of much larger dimensions can be executed, consequent upon the slide being allowed to pass over the stem of the winch-handle, which admits of the various instruments being brought further from the centre of the circular movement; the nut need only be fixed by these holes when required. Fixed in the centre of the plate, for instance, work of $1\frac{1}{2}$ to 2 in. only could be decorated, but when fixed at the end, by the two holes as seen in the engraving, the slide is allowed to recede 2 in. or more further from the axis of the wheel, and larger work can be done. In recognizing this fact, it must be remembered that such instruments as the horizontal or universal cutter project a long way from the face of the tool-box, and thus occupy the space which is required for the work to revolve in.

Another improvement is the adapting of the tangent-screw to receive the whole of the spiral apparatus. This is done by fixing a strong metal arm to the plate of the second slide under the centre of the tangent-screw, the object of the arm being to support the end of a spindle, which is fitted to a bearing as seen in Fig. 173, and on which the various wheels of the spiral apparatus are fitted; the bevel wheels are used to connect the rest with the rotation of the lathe-head. The end of the arm has a curved slot, which allows the tangent-screw to be moved in and out of gear, without taking off the spindle, the end of which is made to receive a winch-handle for ordinary purposes.

The segment-stops are also another important addition. It will be noticed that a series of holes is drilled round the top of the worm-wheel; into these are placed two steel pillars with adjusting screws, in place of the now obsolete arrangement of pairs of pins of various sizes, with flat heads. The points of the screws come in contact with a projecting steel pillar, which can be placed on either side to correspond with the alteration of the third slide.

CHAPTER X.

MANIPULATION OF THE SPHERICAL REST.

THE difficulty of producing an accurate sphere by hand-turning, and of decorating curves with continuous ornamentation, has brought the simple rest, as known to Bergeron, to its present state of perfection, and made it a most valuable addition to any ornamental turning lathe. It has no less than seven movements, by means of which convex and concave curves of any degree are readily obtained, from a small bead around the periphery of a large piece of work, to a sphere of 4 or 5 in. in diameter; and when so turned, the bare form may be ornamented to any extent by replacing the fixed tool with the various revolving cutters, the termination of each cut or flute being determined by the segment-stops, which fix into the worm-wheel.

The curves produced, whether concave or convex, and their position, depend entirely upon two conditions: First, the position of the worm-wheel; secondly, whether the tool be on the far or near side of the centre of the

worm-wheel. To ascertain the position of the worm-wheel, it is necessary to mark a zero line upon the first slide, which is effected in the following manner:—Turn a cylinder, mark on it a fine pencil line, place the rest on the lathe with the axis of the worm-wheel as nearly as possible under the pencil line, place the fourth slide parallel with the third by means of its index and divisions on ring, and both parallel to the first slide; place a double-angle tool in the tool-box, and, by means of the second slide, bring its point exactly opposite the pencil line; throw the tangent-screw out of gear, and turn the worm-wheel exactly halfway round, and by means of the first slide it is so adjusted that the tool shall just touch the line, both on the far and near sides of the cylinder; the axis of the worm-wheel will then be exactly under that of the lathe. The zero line should then be cut on the surface of the first slide. The worm-wheel can always be adjusted to the zero line, which will in most cases be found sufficient for practical purposes.

Having obtained the means of placing the worm-wheel accurately in a transverse direction, it is necessary also to do this in the longitudinal, which is effected as follows:—Place the third slide parallel with the second, and move the rest until a straight edge placed on the face of the work coincides with

the zero line which passes transversely through the axis of the worm-wheel.

To illustrate the working of the spherical rest, let it be desired to cut a boxwood sphere of 2 in. diameter; turn the wood true at the end and reduce it to a cylinder of the required size; mark a fine pencil line 1 in. from the end; it should then be turned approximately spherical by hand; place the slide-rest then on the lathe with the axis of worm-wheel under the pencil line, and the first slide at zero. This done, the first and second slide must not be moved; any other alteration may be made as you please. Now, if an ordinary slide-rest tool were used, the fourth slide would come in contact with the shoulder of the work, or the chuck on which it is, long before the tool had traversed round the sphere far enough for even general purposes, hence the necessity for the application of the curved tool (Fig. 178); this would completely sever the sphere, but a stem sufficiently strong to hold it must be left until the whole of it is turned; it can then be detached by a tool of a similar shape, but with an acute point (Fig. 179).

It is obviously impossible to ornament a sphere entirely from pole to pole by one chucking only, but this can be effected by a line marked exactly upon the equator, and after one hemisphere is decorated, it

can be rechucked the reverse way with the equatorial line perfectly true with the surface of the chuck, a proceeding which will require great care, as it is a somewhat difficult process.

Next let it be desired to excavate a hemisphere, the reverse operation to the last. To do this, turn the end of the work true, place the spherical rest with the first slide at zero, and the third slide parallel to the second, so that the zero line of the worm-wheel shall exactly coincide with the surface of the work. This is effected by means of the second slide, thus—Commence with a straight round-nosed tool, which must be let in gradually while it sweeps out the material as the excavation progresses; when the fourth slide comes in contact with the edge of the work, a curved tool must be substituted for the straight one, and the hemisphere completed. In practice, the bulk of the material would be removed by hand-turning, and the hemisphere finished only by the spherical slide-rest.

A diagram illustrating the curves, though simple, may be desirable. Let MP represent the axis of the lathe from mandrel to popit-head, C the centre of the work, and AB the diameter and back of work. (1) With tool at radius CB , and worm-wheel coincident with C , the hemisphere ADB results, and the alteration of the radius would only increase or decrease it; (2) if

worm-wheel be 0.25 nearer P at M, the curve E F G results ; (3) if worm-wheel be 0.25 nearer M at O, the curve H K L results. It is to be observed that these

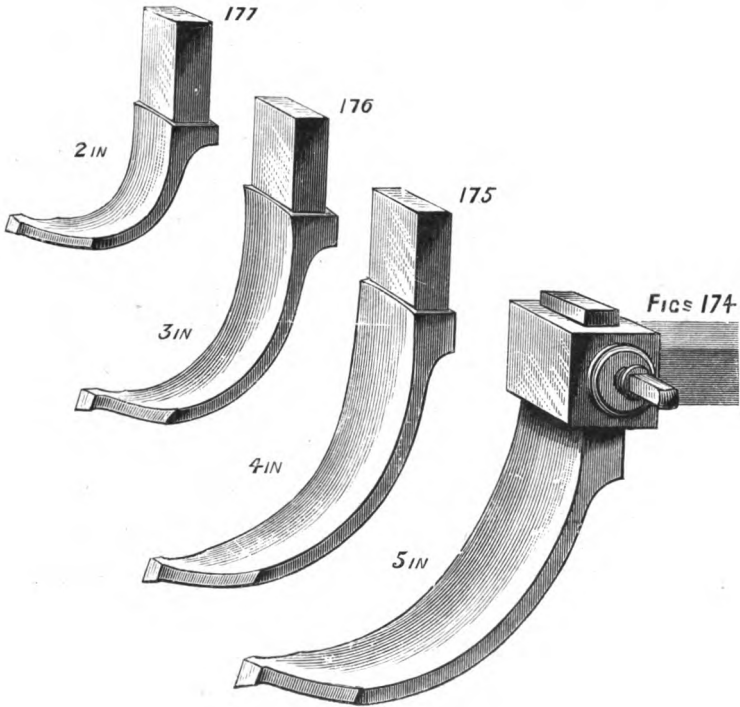

curves, E F G, H K L, must fall within the diameter A B, therefore this must be compensated by an increase of radius if the diameter A B is to be preserved ; and again this increase of radius will necessitate another

compensation EG if the hemisphere ADB has been cut, and it is desired to cut a curve AKB , passing through the point AB , and also through K , a point 0.25 nearer to M ; then by means of the second slide the worm-wheel must be moved from C to O , *i.e.* 0.25 nearer to M . But curve AKB falls within the points AB by, say, 0.05 , therefore the radius must be increased by 0.05 ; but this will bring the curve 0.05 further from M beyond the point K , consequently the worm-wheel must be moved nearer to M by fully 0.05 , for as the worm-wheel is moved towards M , so does the curve AKB fall still further within the points AB ; (4) it is obvious that as the worm-wheel approaches M , the flatter does the curve become, as ARB , provided that by increased radius the tool still travels through AB , and conversely, as the worm-wheel approaches P a greater portion of the sphere results; (5) if you regard AB as the axis of the lathe, and MP as the diameter of the work, the same reasoning applies to oblate and prolate spheroids. These may all be ornamented by means of revolving cutters, or a drill, and the flutes may, by traversing the first and second slides, be continued at right angles to the axis of the lathe or parallel with it.

The author has pleasure in bringing under the notice of amateur turners the spherical parting tools invented and patented by the Rev. C. C. Ellison. They are made in sets of four (Figs. 174, 175, 176,

and 177), sufficient for all general purposes. They all fit into a steel bar, which is also useful as an internal boring or parting tool. The blades vary from 0·8 to 1·5 in. in width, and are as simple in appearance as they are difficult in production, being turned by a

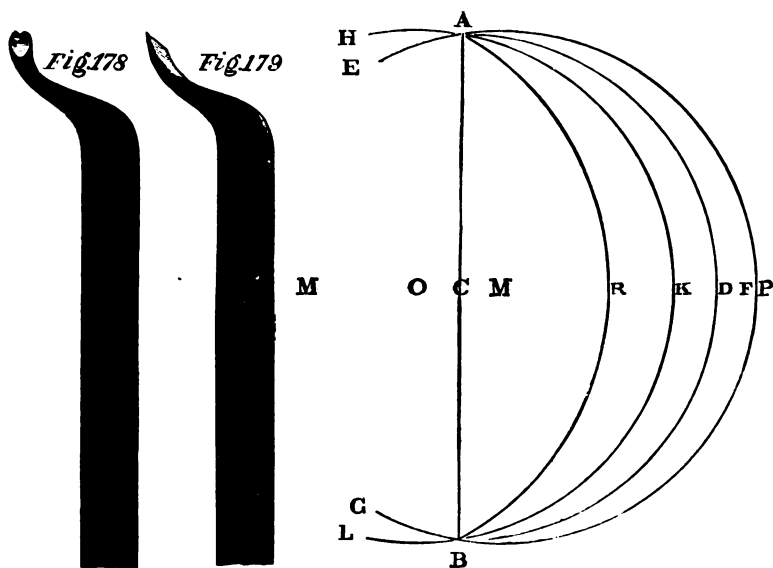

specially constructed tool to the exact radius of the curve they are intended to cut, viz. 2, 3, 4, and 5 in. diameters. By their assistance the whole of the inside of a hemisphere, either of soft wood or ivory, can be turned out in shells clean and true to shape, and ready without further labour to be chucked and ornamented;

thus a very large amount of valuable material is saved. They are used thus—Suppose the material to be a solid block of ivory, turn the surface true and polish it, make five circles of 2, 3, 4, and 5 in. diameter, place the tool-box of the spherical slide-rest level with the front of the fourth slide, and fix it by both depth and stop-screw, using, of course, the bridle to the former; it is necessary that both screws should be fixed, lest vibration should occur; place the steel bar quite home in the tool-box, adjust the rest to excavate a hemisphere, and fix the 2-in. blade quite home in the tool-box, throw the tangent-screw out of gear, release the fixing-screw of socket-ring, and adjust the inside edge of the blade to touch the 2-in. circle, and the inside curve of blade to a trifle less than 1 in. from the centre of the face of the ivory; the exact position being determined by a brass gauge made for the purpose.

Place the tangent-screw into gear and tighten the fixing-screw; the tool may then be passed into the ivory by rotating the tangent-screw, and a solid 2-in. hemisphere will be cut out; readjust the slide-rest, substitute the 3-in. blade for the 2-in., proceed as before, and a hollow hemisphere will result. The same process must be repeated with the other blades. Where hemispheres of larger dimensions are required, the blade may be taken out, sharpened, and replaced



with mechanical accuracy. There is one important arrangement to notice, without which some difficulty may arise when operating upon work of the larger diameter. While the blades can be made of any strength, the spherical rest, from its construction, is of necessity comparatively unstable, and to counteract the great strain in cutting a large diameter, a piece of soft wood must be placed against the face of the work, and between the bottom of the blade and the top of the third slide; this prevents vibration and strain upon the rest. If it is desired to cut out shells greater or less than a hemisphere, the axis of the worm-wheel must be moved further from, or nearer to the lathe-head.

Although a variety of tools have been made for use in spherical slide-rest, the ordinary slide-rest tool will do a deal of the work, but curved tools are essential. Fig. 178 is an excellent tool for roughing-out the work externally, while Fig. 179 is employed for cutting off. There should be about four sizes to suit different diameters of work.

On Plate 14, Mr. Ellison further enables me to give an illustration of one of the best specimens of spherical work yet produced, by a combination of the rose engine, ellipse chuck, and the spherical slide-rest, and it is hoped that the following details will enable any amateur possessed of the necessary apparatus to

reproduce it: the ring or moulding was cut first, and as no larger ivory could be procured, the two blocks (weighing 7 lbs. each, and measuring $7\frac{1}{2}$ by $6\frac{1}{2}$ in. in the rough) for the two halves of the vase had to be reduced; one block for the lower half was chucked and turned true upon a double eccentric and ellipse chuck, the sliding ring having 0.55 eccentricity, a groove cut 0.1 in. wide and 0.2 in. deep at 0.25 from the edge; the block was reversed in the chuck, and a corresponding groove cut upon the opposite side. A hole was then bored from one to the other, and by means of a frame-saw, the grooves serving as guides, an oval ring, 6.8 in. by 5.8 in. by 0.25 in., was severed; next a large oval picture-frame was cut off, but not until the rebate and back had been turned and polished.

The block was then re-chucked the reverse way, and fitted to receive half the thickness of the ring; by means of the spherical rest and inside parting tools, the inside was cut out in frames, finished off with a cutter-bar and polished. Then it was re-chucked the reverse way by the rebate, and the rose-engine oscillating movement so adjusted by a spiral level that one point of the rosette was in the same horizontal line as the longer or major axis of the ellipse; the edge of the revolving cutter was placed in the same plane, and its axis in the same vertical plane as the back of the work, where it thus cuts the full depth of

the pattern. This done, the rosette was moved exactly one half of its wave or pattern. The tangent-screw was moved four complete turns, and the cutting repeated to the same depth; the rosette having been moved back to its original position, a similar cut was made; and so on until the pattern was completed; the other block was treated in the same way, and also made to fit into the ring. For the base, the ellipse chuck received 0.4 eccentricity, and it was cut in the same manner as the halves of the body, the rest having been adjusted to the requisite curve; the ring between the base and body received 0.45 eccentricity, and was cut like the ring on the top, upon the face and each edge; the finial was begun with 0.4 eccentricity, gradually reduced to 0, and was cut with a vertical cutter revolving the reverse way to the lathe. The ivory in the rough weighed $18\frac{1}{2}$ lbs., and was worth £14. The finished vase weighs 1 lb. 14 ozs., and about £6 in value was saved in frames, etc.

The cutter used was designed by Mr. Ellison, and deserves mention. It consists of a steel disc, 1.5 in. in diameter, 0.3 in. thick, having fifteen teeth inclined over the radius at an angle of about 15° , the face of the teeth being at an angle of about 30° to the axis of spindle, so that the best cutting edge, perhaps, is combined with such clearance that the ivory shavings flow out like a stream of snow-flakes. The rapidity

of cutting is such that a 4-in. hemisphere can be fluted with only one sharpening of the cutter, and in less time than is required by the usual fly-cutter; the work, moreover, is left in a highly polished condition. With a fair amount of practice, any amateur turner of average experience can so far master the spherical slide-rest as to produce and ornament a vast variety of curves, in as great a number of different positions. Such a tool can only be regarded as a most valuable addition to a lathe.

CHAPTER XI.

VASE ORNAMENTED WITH SPHERICAL SLIDE-REST.

THE vase represented by Plate 15 further illustrates the different applications of the spherical slide-rest, and the following details will, it is hoped, enable any amateur turner to reproduce it. It may, of course, be reduced or enlarged, as well as made from various materials. That from which the illustration was taken is made from boxwood only, which arose from the fact of its being made by the author during some experiments and improvements that were carried out with reference to the spherical slide-rest.

As a first trial, perhaps it will be as well to appropriate the same material, but for a finished specimen it should be made either in ivory or African blackwood, one of each of which has been made by amateurs from the details as they appeared, and is considered in every way satisfactory. The first attempt to reproduce a piece of work of this nature may not result in an exact copy; this is scarcely to be expected, as the instrument is in itself complicated, and it will require some practice

to overcome the difficulties of such an intricate piece of machinery ; this, however, is modified by the explanation of the manipulation of the slide-rest in the previous chapter.

When about to turn such a vase, the proportions must claim the attention of the operator, and the material, whatever it is, must be selected with care as to the size and grain. Should it be desired to produce a fair copy, the dimensions of the original are $12\frac{1}{2}$ in. high, the tazza $5\frac{1}{2}$ in. diameter. Those portions of the material that will not turn up to the required dimensions must be discarded, and replaced by others. If the sizes of the various parts are not so maintained, the result will probably not be satisfactory. The author does not presume to anticipate that the vase illustrated may not be greatly improved by many of the experienced amateur turners who may read this work. The above remarks therefore refer to the production of a true copy only.

The material to be used must now be left entirely to the taste of the turner, but, as a basis, we will assume that ivory has been selected for the purpose. The base, which is a plain ogee, should be cut from the hollow end of a tusk, the body also cut from a similar part, but of smaller dimensions ; the former may be held in the following way : from the unevenness of the interior, it will probably not be expedient to turn

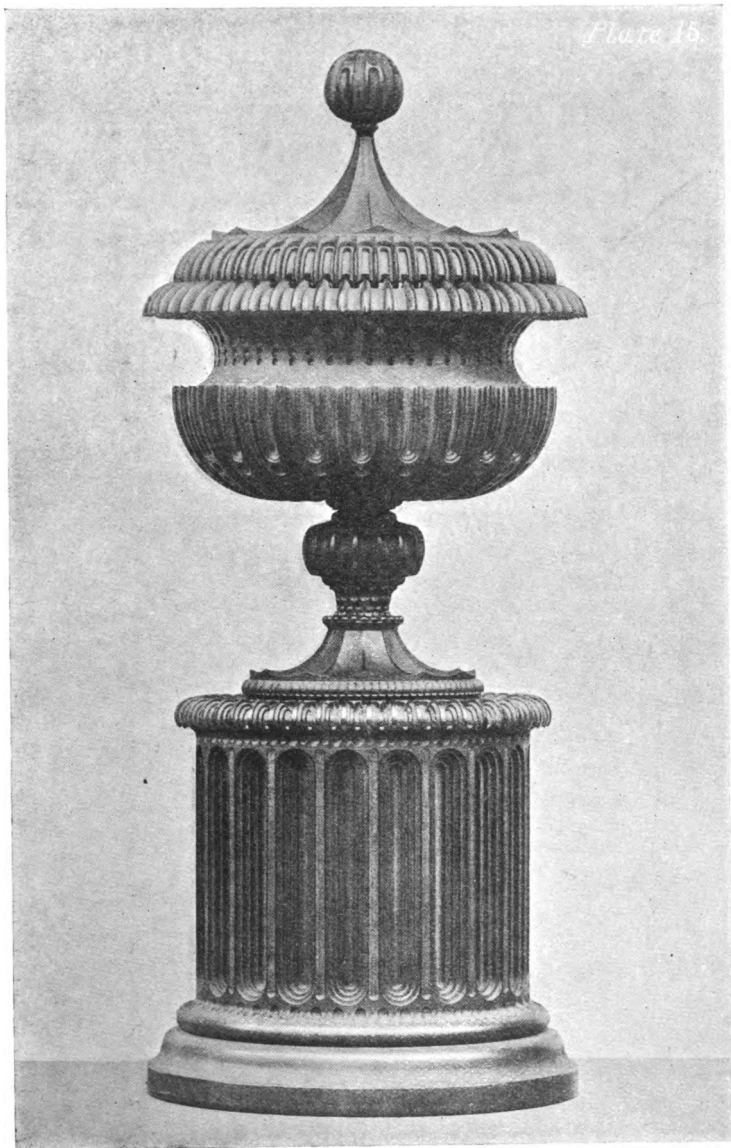

it out, in which case a boxwood chuck should be turned down to allow the ivory to pass over with sufficient freedom to admit of the external diameter being set as near true as possible; the ivory is then fixed to the face of the chuck with strong glue.

The figure is then carefully turned, and being quite plain, is executed by hand-turning; the front is next turned out to a suitable diameter, and screwed to receive the body, which, when fitted, is held in its place for further operations, as the base into which it is screwed forms a permanent chuck.

The body is fluted with a large-size step-drill employed in the ordinary ornamental slide-rest, the fluting-stop as previously described being used to determine the length of each; these flutes being deeply cut, and the tool of extra size, each one will require a series of cuts to complete it, and in working round a large diameter of this material, it may reasonably be expected that the drill will lose a deal of excellence in its cutting powers. Therefore, when cut round, the drill should be taken out and very carefully re-sharpened, and a light cut again taken over each flute. If from the fact of sharpening the drill a slight deviation of its profile should occur, it will not interfere with the result, as a slightly increased penetration will cause the exact form of the drill to result. Between each flute, sufficient space is left for a second (drill a round-nosed one)

to be inserted. The original is 4 in. in diameter at this part, and contains twenty-four deeply cut step-grooves or flutes, the smaller drill being inserted between each. At the lower extremity of the flute, a rather larger round-nosed drill is employed to seriate the hollow.

The convex, curved lip at the top of this part is now turned, and this affords the first instance of the application of the spherical slide-rest. The curve being approximately reduced to shape, the spherical rest is placed on the bed of the lathe and fixed. The main slide is then adjusted to the precise centre of the lathe-axis, and the slide which carries the worm-wheel so fixed as to place the latter under the centre of the curve to be turned. This will at first be found a somewhat troublesome job, but a little experience will soon obviate any difficulty; once set, the work is turned in plain form, and, as it is afterwards fluted with a smaller sized step-drill, the drilling instrument is substituted for the fixed tool. Should the point of the drill not traverse round the curve sufficiently, it may be adjusted to do so by turning the tool receptacle in the socket, but on no account whatever must the position of the worm-wheel be disturbed. The difference in the position of the fixed tool and drill will arise simply from the fact of the plain form being turned with a curved tool, while the drill is central to the stem of the instrument. The distance the drill is allowed to travel is determined

by the segment-stop in the worm-wheel. Thus far the body may be considered finished, and the recess in the top of it only remains to be turned out and screwed to receive the foot of the tazza, or upper part.

To proceed, the foot of this part, when fitted to the base, should be removed, and held in a wood chuck screwed to receive it, and, for further security, a little glue may be placed between the two faces. This is not absolutely necessary, and may be omitted if the fitting is well made; but in the case of any excessive excavation being required, it is always a safeguard against the work moving in the chuck.

The concave curve roughly shaped, the spherical slide-rest is adjusted, and the tool extended beyond the centre to suit the curve, which is then accurately turned; the vertical cutter (Fig. 95) is then placed in the tool-box, and, by shifting the tool-slide in the socket, the point of the cutter is brought to the desired position to follow the curve. The vertical cutter alluded to is the most suitable for application in this slide-rest, from the fact of the spindle extending to one side only, as there is no framework to prevent the tool passing round the curve, by coming in contact with any shoulder, or face of the chuck, etc. The tool thus adjusted, twelve consecutive cuts are made by employing the 96 division arrested at every eighth hole. At the base of this curve a very small convex curve is seriated, and at the

top a circle of small beads ; these should be cut with an astragal tool, so that the beads stand well apart. The intermediate part or stem is carried out in the same way, being first shaped, and afterwards ornamented.

We now arrive at that portion which may be considered the most difficult, and that which, if carefully turned, will complete the design. The whole of that part forming the tazza is in one piece, and this, perhaps, renders it more difficult to execute. The rough block of material is held in the universal chuck and the inside turned out, and, in the first instance, a short, slightly taper fitting should be left. It is then removed from the universal chuck, and re-chucked upon a boxwood plug by the inside fitting. The convex curve forming the bowl is approximately shaped, together with the upper concave curve. The spherical rest is then carefully adjusted to the precise axis of the lathe by the lower slide, while with the second slide the axis of the worm-wheel is placed under the centre of the hemisphere to be turned. A straight tool will be found to pass round far enough for this purpose.

The drilling instrument is then substituted, and a step-drill employed of smaller dimensions than that used for the base. The segment-stops are arranged so that the drill will pass out at the diameter of the work, and is arrested as it approaches the centre to the desired point. This part contains forty-eight consecutive

incisions, half of which are first cut; the intermediate ones are arrested at half the distance, in order that the form of the curve should not be destroyed by their too close proximity at the centre, and this also allows a series of round-nosed drills of different sizes to be studded seriatim over that part left uncut. It must be mentioned that when cutting the second series of step-flutes, the segment-stop should be re-adjusted to prevent the undue traverse of the drill.

It is found in practice that much of the material may be excavated by the partial rotation of the circular movement by hand, but for all finishing cuts the tangent-screw should be placed in gear, and the motion governed by it.

The second slide must now be adjusted to the concave curve; this will require a careful setting. The series of round-nosed drills is again employed to decorate this form; the work is then removed, and again chucked by the convex curve. This will also require considerable care, as it is held by the spaces left uncut by the step-drill; it will, however, hold perfectly tight in the chuck if correctly fitted. The convex curve at the top is then turned, and the spherical rest again set to suit the curve. This is ornamented with a series of ribs or reeds; these were cut with a quarter-hollow drill with an astragal end, which creates a space between each; and as the distance at which the drill

was arrested for each cut did not allow the true form of the hemisphere to result, the reeds are of an elliptic form, which add to, rather than detract from, its appearance.

So far, the whole specimen is complete, with the exception of the cover. Some who have examined this vase have expressed an opinion that it is improved without the latter; this may at the same time be considered a matter of opinion, and any turner deeming it worthy of reproduction, can omit this part or not, according to taste.

The manner in which this part is turned is similar to the details already explained, the vertical cutter being used for the concave curve in the same manner as employed for the foot. The cover, it may be remarked, is not intended to fit closely on the curve, the spaces rendering the vase appropriate as a receptacle for *pot pourri*.

CHAPTER XII.

ELLIPTIC CASKET.

THE illustration contained in Plate 16 affords an opportunity of explaining the use of the spherical slide-rest, in combination with the ellipse chuck, by which very elegant designs are produced and decorated.

The following instructions will be of service in the reproduction of a similar specimen: first select a piece of ivory cut from the end of a large hollow, and in doing so let it be of considerable substance, in order that the concave curve may be turned without encroaching too closely to the inside; it must be at least $\frac{3}{4}$ in. thick. Such a piece of ivory is prepared in the following way: first face it over on one side, after which it is fixed to a wood chuck by glue, and placed on the ellipse chuck; when perfectly dry, a rebate is turned out at the opposite end, and the face turned quite true to it.

In setting the sliding-ring of the ellipse chuck to the required eccentricity, it must be arranged to suit the proportions of the material, by which the largest

size possible is obtained; the end faced, and the rebate turned, it is removed from the chuck; a second wood plug, driven lightly into a metal chuck, is then mounted on the ellipse chuck, and turned to fit the rebate accurately, when it is again glued and allowed to dry. The rebate is useful in two ways: first, it forms a means of securely holding the material to the chuck; secondly, it is for the purpose of receiving the false bottom, which is ultimately required. It is absolutely necessary to employ a metal cup chuck, for the reasons explained in the chapter on the manufacture of the ellipse chuck; and the eccentricity of the ring, which, for the subject under notice was fixed at $\frac{6}{10}$ in., must remain the same throughout.

To turn the body of the box to the shape will be the next proceeding. The spherical slide-rest is adjusted by the two lower slides, and as there is a considerable amount of material to remove, a strong tool is necessary, therefore, one with a shaft or stem fitting the tool-box is preferable.

Having roughed out the shape, the tool must be carefully sharpened for a finishing cut, which should be made with the worm-wheel, under control of the tangent-screw. At the base, a large quarter-hollow tool is employed, to form the plain moulding; when turning this, the tool is placed in position by the worm-wheel, and there held while it is inserted by

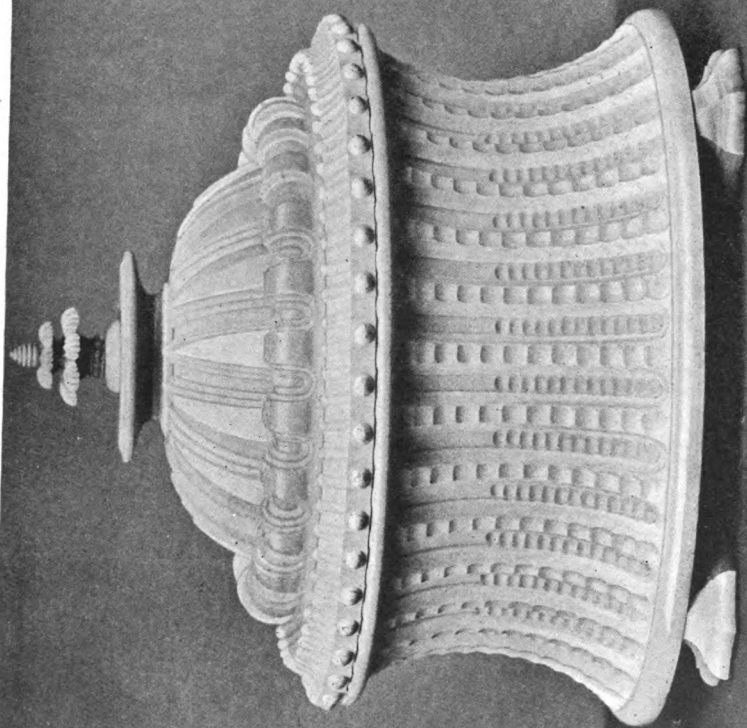

the guide-screw of the top slide. The tool is then changed for one of smaller size, and the corresponding form turned on the top. Before attempting to decorate this part it should be highly polished, as explained in the chapter relative to that particular branch of the art.

The fixed tool must be replaced by the drilling instrument, with a large round-nosed drill, and the segment-stops adjusted, to arrest the partial rotation of the worm-wheel at the desired distance on each side of the centre. The ellipse chuck is then set vertically, and the first cut made at the zero of the 96 circle of holes; the tool is penetrated to the necessary depth, and the stop-screw set. The cut is repeated at every third hole of the division, resulting in thirty-two consecutive cuts. A second drill, smaller in diameter, and with a square end, is then used to cut the recess deeper, the segment-stops being readjusted, so that the same substance is left at each end.

The tool is again changed for a round-nosed drill, about $\frac{2}{100}$ of an inch larger in diameter. It is then set by the tangent-screw to first cut the hollow nearest the base, which is repeated all round. It is then moved by the tangent-screw two-thirds of its diameter, and again inserted, the stop-screw having been fixed to determine the penetration. It only remains to repeat this twelve times to complete that part. It

will be seen that the spaces left between the flutes are also cut in a similar way. The drill is replaced by one of larger diameter, and the starting-point rearranged, which will require the aid of the adjusting index, in consequence of the dial-plate being moved three holes for each cut. Having adjusted these points (which have been previously referred to), the drill is inserted to about three parts of the entire curve, and then moved a corresponding distance by the tangent-screw for the second series; this, repeated twelve times, will carry them throughout the curve. This is a very effective pattern, and, if well cut, will not require further treatment in the way of polishing.

The lid or top of the casket must next claim attention; this, for convenience and economy, is made in five separate pieces. The ring which forms the fitting is the first to turn, and it will be an advantage in every way if it can be cut from the same tusk of ivory. A piece $\frac{5}{8}$ in. thick will be sufficient to allow for chucking, also the part which forms the fitting for the bottom. This should be first held by glue, and the fitting accurately turned; by this it is again chucked while the top is ornamented.

This part will not require the spherical slide-rest, which may, therefore, be removed, and the ornamental rest employed. A hollow is first turned in the face, leaving a rim $\frac{2}{10}$ in. wide. A round-nosed drill is then

used, which is passed through the edge at every third hole of the 120 circle of division, resulting in forty incisions; this process has left practically forty squares, and upon the top of each one it will be seen that a bead is cut. This is done by simply adjusting the tool to the correct centre, and employing a bead-drill with a broad astragal end. A large round-nosed drill, $\frac{40}{100}$ in. wide, is then used, to seriate the hollow which is incised at every hole of the same division, 120; above these, on the top, a row of smaller beads is cut at every second hole, leaving 60. The return concave curve towards the centre is also cut with a larger drill in a similar way; this, however, from the nature of the illustration, is not clearly developed. The following ring it, will be seen, has required the spherical slide-rest in its decoration: it is first turned true to shape, and to fit a recess in the previous one, which is made to receive it, and then chucked by the inside. The eccentricity of the ring being still the same, the spherical rest is adjusted to bring the centre of the worm-wheel under that of the ring, and the tool necessarily moved near to the centre of the wheel, to operate on so small a curve. Having turned the plain form, it should, like its predecessors, be highly polished.

The ellipse chuck is again set vertically, the pulley fixed at the 96 circle. A bold step-drill replaces the fixed tool, and is carried as far round the curve as

possible, the segment-stops being again required. There are twenty-four cuts, and it is a pattern that will require considerable attention and patience in its execution, but well repays the time spent upon it.

The dome top will next require to be turned. This is made from a solid piece of ivory, and is carefully fitted at the base to the interior of the ring preceding it. The spherical rest is adjusted in the same way as for turning a hemisphere, which the subject illustrated is similar to, although of an elliptic form. Here, again, the polishing must claim attention. A still bolder step-drill is then used, and fifteen cuts only are made round it, leaving a broad polished interval, which greatly adds to its appearance; the points of the different steps, all resulting in sharp terminals, are also decorative.

To complete the casket, nothing remains to be done but the finial. This, it will be seen from its diminished size, terminates in a long elliptic form, which is left perfectly plain. On the top of this is an ornament, which is made in three pieces, and cut seriatim at different angles and curves, forming a kind of rosette.

The only parts now to be done are the feet, which, from the fact of their being, so to speak, the foundation, may be considered to be the first part; it is, however, immaterial. Although a somewhat minor portion of the box, they require considerable care to produce

them all exactly alike. A brief explanation of the way in which they were made will be of service in their production.

The four pieces of ivory are first turned by hand to the required form, and screwed where they enter the bottom of the box; they are then held by the screw while cut with the vertical cutter, which may be done either with one complete moulding-tool or two separate tools, and being all cut at the same setting, they are all precisely the same shape.

CHAPTER XIII.

THE GEOMETRIC SLIDE-REST.

THIS slide-rest was invented and patented by Captain R. Pudsey Dawson, and is a most useful and interesting addition to the amateur's lathe. It is applied in

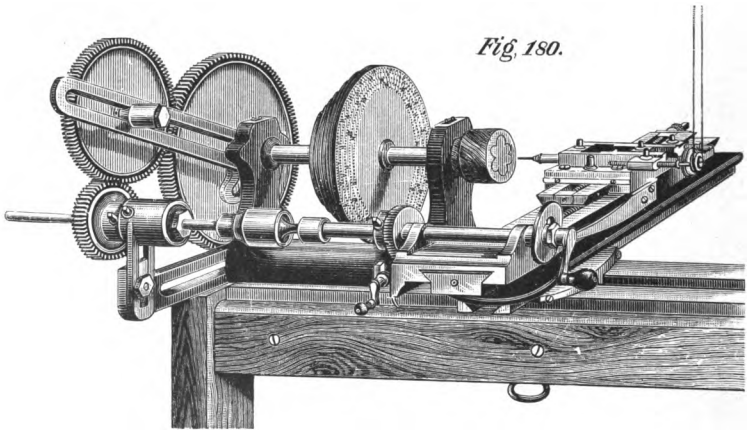

combination with the spiral apparatus, as will be seen by reference to the engraving, Fig. 180, and its general construction will be understood from the following details.

A cast-iron pedestal is fitted to a cradle in the same way as the ornamental-turning slide-rest—in fact, the same cradle can be appropriated. To this base a metal ring is fitted, for the purpose of raising and depressing the height of the tool. A cast-iron slide 12 in. long is then fitted by its stem, in a similar way to Figs. 13 and 14; this slide is set transversely across the lathe-bed when the rest is in use. A metal plate is accurately fitted, to slide from end to end, and is actuated by a strong spring, which takes the place of the screw. On the top of the metal plate a second, but shorter, slide is attached, and moves with it. This slide is provided with a screw of ten threads to the inch, the tool-box being fitted up in precisely the same way as the ornamental slide-rest.

Across the front end of the lower slide a metal frame is fitted to lay parallel with the lathe-bed; this carries a spindle which extends at both ends, on one of which a cam is fixed, and by this the action of the slide and spring is governed, while the extension at the opposite end is to connect the movement with the spiral apparatus, and, as illustrated, it will be seen that on the improved plan the latter is attached to the back of the lathe-head. To the spindle, close to the metal frame, a worm-wheel is fixed, with a tangent-screw working in a metal frame, the latter being placed

in and out of gear by a cam and spring, similar to that on the eccentric chuck.

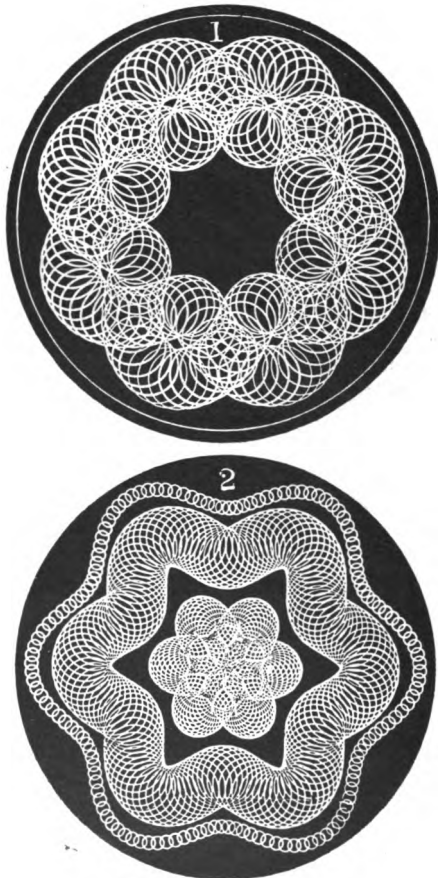

Fig. 180*.

The action of the slide-rest, when in use, is as

follows: the main slide is set perfectly true, at right angles to the lathe, to turn a flat surface, which is effected by the main screw of the second slide, the depth of cut being decided by the guide and stop-screw of the top slide. The surface of the material must be turned before any connection is made with the spiral apparatus or cam. Having surfaced the work, the necessary train of wheels can be arranged, and the cam adjusted so that sufficient tension is given to the spring to maintain the pressure of it against the small, steel roller attached to the curved arm, which is fixed to the first slide, as seen in the illustration.

The transverse spindle which carries the cam is then connected to that which passes through the socket of the spiral apparatus by a universal joint, and when the winch-handle is turned, the uneven form of the cam causes the lower slide to oscillate, while, by its combination with the spiral wheels, the work is rotated at the same time.

Many very beautiful patterns may be cut on the surface; a few of the various combinations are here illustrated. For simple line patterns cut with a fixed tool, the movement of the winch-handle is sufficient, and produces very good work; but the apparatus is by no means confined to this particular class of decoration.

All the revolving instruments may be employed

with it, and when these are used, it is necessary to

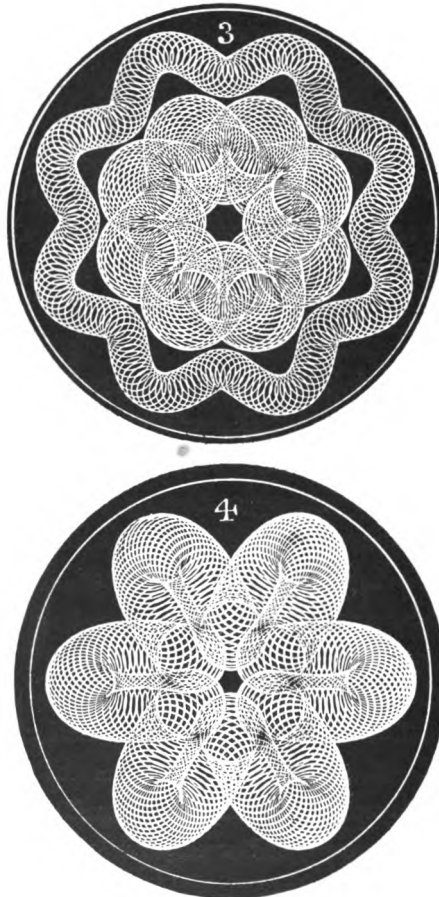

Fig 180*.

have the tangent-screw in gear with the worm-wheel,

and by this the consecutive cuts are spaced out. The worm-wheel having 96 teeth, the distance for each cut is determined by the number of turns of the screw, or the divisions of the micrometer on the same.

When cutting deep patterns, which are very much more effective and useful for decorative purposes, the tool is inserted by the top-screw; and by the continuous rotating of the tangent-screw by its winch-handle, the cut is carried throughout the work. The variety of designs may be largely increased by the work being placed on the eccentric chuck, or employing the spiral dividing chuck, especially the latter, in its present convenient position at the back of the lathe-head.

A further variety in line patterns may be obtained by employing a fluting-stop, by which the traverse of the tool is arrested before reaching the limit of the cam, thus leaving part of the pattern a portion of a concentric circle only, as in No. 6, Fig. 180*.

The cams most suitable for the geometric slide-rest, and generally made, are the ellipse, eccentric, and heart-shaped; both the plain eccentric and ellipse have their centre apertures elongated, so that each may be made to produce a greater variety of patterns, consequent upon the different positions in which they are fixed upon the spindle.

The examples illustrated have all, with two

exceptions, been executed with the eccentric cutter

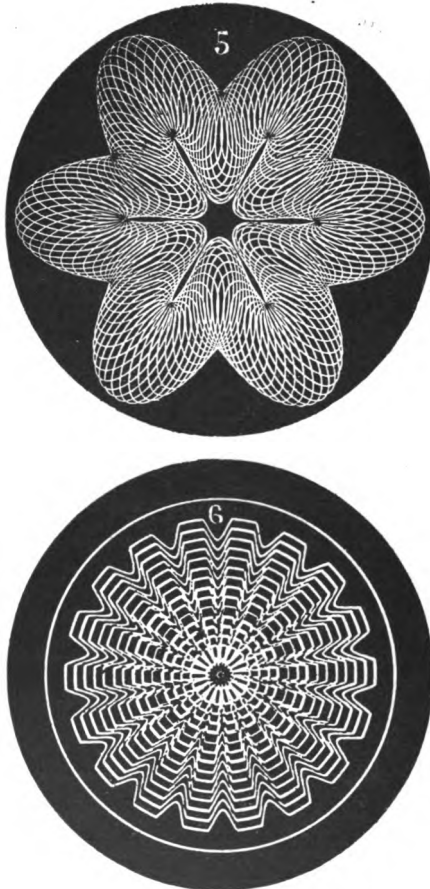

Fig. 180*

No. 5 being cut with the ellipse cutter, while for No. 6

a fixed tool only is employed, arrested by the fluting-stop. This style of work may be largely extended by the various combinations of the cam and change wheels; such patterns as this, however, are not suitable for deep cutting. The number of curves may be reduced, and panels, arches, and miniature frames of elegant designs may be produced, moulded and shaped in endless ways by figured drills and cutters. The apparatus altogether forms a most interesting study, and may be made productive of work unattainable by any other means.

CHAPTER XIV.

THE ELLIPSE CUTTER.

THIS instrument (Fig. 181), as it is now made, consists of two distinct parts: the means of producing the ellipse, and that also of correcting the angular

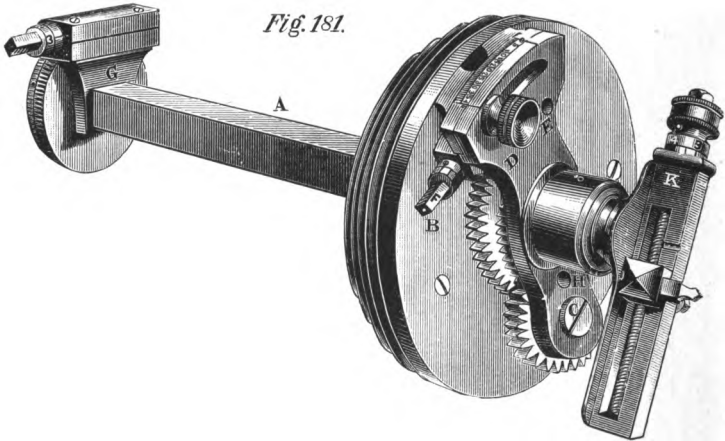

aberration consequent upon altering the eccentricities. The first part, namely, the means of cutting an ellipse, was invented by the late Major James Ash, but from

the inability to correct the position of the figure, or to compensate the movements, it was not considered, nor was it, a perfect instrument. The second part, which consists of a worm-wheel and tangent-screw movement at the back, was afterwards invented by Mr. H. Perigal, F.R.A.S., and this, it will be seen from the following details, has overcome the difficulty and rendered it a complete and perfect tool. It produces also looped figures of many proportions, which may be cut in a variety of positions, and grouped to form a very large number of different patterns; its manipulation will be materially assisted by the details of its manufacture, of which the following is a brief outline; the same will also be of service to scientific amateurs in making one of the kind.

A square stem, A, is fitted to the tool receptacle of the usual size; at the front end a flange is forged, with a plain pin about $\frac{7}{8}$ in. in diameter projecting from it; a long spindle passes entirely through the length of the stem, and has a wheel of 48 teeth fixed to it. The metal plate B, which has a deep boss on the back, is then bored out, and a hardened steel collar driven tightly into it; it is then ground out and accurately fitted to the front part of the stem, and revolves between the face of the flange and that of the spindle to which the 48 wheel is attached, a portion of the latter being turned away to relieve the friction; a hardwood

pulley is then fixed to the plate by two screws, for the purpose of driving the instrument by the overhead motion. When thus driven, it will be seen that the metal plate, in its revolution, carries every part attached to it, and moves round the 48 wheel on the spindle.

On the front of the plate a steel stud is fixed, being under the screw *c*; and at the opposite side a metal block is securely attached by two screws at the back, and is turned to a true curve from the centre of the axis of the stud. A metal flange, *D*, is then fitted (as seen in the engraving, Fig. 181), one end being made to fit over the end of the stud, while the opposite extremity is turned from that centre to fit the curve which has been previously turned from the same point (great accuracy is necessary in these parts, as the flange rests and moves upon them); a curved mortise is then made in the wide end, through which a milled-head screw passes and holds the flange tightly to the block. A short piece of metal is then fitted through the plate *B*, and held to it by a screw at the back, but with a freedom of movement; through this a screw of ten threads to the inch is fitted, having a flange in front and a small metal collar pinned to the opposite side to retain it in its place; the screw is equal to ten threads to the inch, and works in a nut which fits in a round hole in the flange, marked *E*, the end of the screw *F*

being made square, so that the ordinary key will move it when required. The socket that holds the screw is made to turn, to admit of its moving the flange from one point to another to adjust the various eccentricities required. The top edge of the flange is divided to an accurate scale from 0 to 40, and read by a line marked on the block to which it is attached. On the end of the spindle, which extends through the opposite extremity of the stem, a worm-wheel of 150 teeth is fixed, a chamfer being turned on the face, which, for convenience in reading, is divided into seventy-five equal parts, and figured 0, 5, 10, 15, 20, and so on; a metal upright is firmly attached to the end of the square stem by two steel screws, to which is fitted the frame holding the tangent-screw that actuates the worm-wheel, the head of the screw being divided into four equal parts.

Having this part so far finished, the instrument should be put together and mounted in a slide-rest, or on a block, so that the hole in the front flange that receives the eccentric cutter may be turned out perfectly true, while revolving on the stem; before the flange is moved, after the above process, the zero line of the division should be marked, as this point will denote the accurate centrality of the instrument. The hole thus turned out is provided with a steel collar accurately fitted. The front eccentric cutter, which is

precisely the same as Fig. 62, as far as it goes, is then fitted, having a short stem which projects through the flange, and to which is fixed a wheel of 36 teeth; two wheels, 24 and 36 teeth fixed together, are then fitted to revolve upon the stud, and by these the 48 on the spindle and 36 on the eccentric cutter are connected; and upon rotating the pulley and flange one complete circle, the eccentric cutter revolves twice in the opposite direction, thus causing the tool to cut an ellipse.

The screw and division of the flange D are of the same value as that on the micrometer of the screw in the eccentric cutter K, which agrees with all screws of a similar description, one turn moving the tool to a radius of $\frac{1}{10}$ inch, while a corresponding movement of the screw F results in the same amount of eccentricity to flange D, and in this way the two movements are adjusted, in proportions required for ellipses of various degrees.

When the instrument is adjusted for use, the eccentric cutter K should stand across the face of the flange at a right angle, and to facilitate this adjustment, a hole marked H is made through the face of the flange D, over the teeth of the wheels, the teeth and space of the latter being marked with a small dot, seen through the hole, thus ensuring the correct readjustment of the wheels when the instrument has been taken apart.

When the flange D and the eccentric cutter K are both set to their respective zeros, the tool simply cuts a minute dot, and this may be described as one test of its accuracy, and if the instrument will not perform this, good work cannot be executed. If eccentricity be given to either the flange D or eccentric cutter K , the tool will describe a circle equal to the same eccentricity, while if the eccentric cutter K be set to a corresponding eccentricity to the flange, the tool will cut a straight line twice the length of the combined eccentricities, and if the eccentricity of either be increased, the tool will cut an ellipse.

The exact proportions of the ellipse produced are decided by the eccentricities of the flange D and the cutter K , the longer or transverse axis being always twice the amount, while the short diameter or conjugate axis equals twice the difference; therefore, any variation may be given to the curve by the adjustment of the eccentricities to produce an ellipse of an elongated form, or the same may be reduced to a circle if necessary.

When cutting a series of ellipses, it will be necessary to employ the worm-wheel or tangent-screw at the back, in order to compensate each row, otherwise they will not stand vertically or coincide in any way. The necessity for this compensation arises from the fact that the course traversed by the revolution of

the eccentric cutter *K* with each separate movement of the flange *D* will cause each succeeding series of ellipses to be more or less at an angle, their direction being to the left if the eccentricity is decreased, and to the right when the same is extended. As before mentioned, the worm-wheel has 150 teeth, with a division of 75 equal parts on the face, the micrometer being divided into four equal parts, and figured 0, 1, 2, 3. It will be obvious that one turn of the screw will move the wheel through the space of one tooth, by which the 48 wheel, attached to the same spindle, is moved a corresponding distance.

One quarter of a turn, or one division of the micrometer, precisely compensates the angularity occasioned by the flange *D* being moved one division of the scale, and as the movement of the flange is increased, the worm-wheel is correspondingly moved in the required proportion, while if the ellipses are cut with the eccentricity of the flange reduced, the worm-wheel must be moved in the same equal proportion, but in the reverse direction. In most instances the worm-wheel is employed to compensate every individual movement of the flange, but it is also used in placing the various patterns in different positions on the work, and is at times used entirely for this purpose, the work being held stationary by the index-point in the dial-plate of the lathe-pulley.

To use the words of the inventor, Major Ash, with whom the author worked at many points of the instrument for hours together: it should in the first place be set all at centre, that is, the worm-wheel, flange, and eccentric cutter are all adjusted to their respective zeros, and when thus set, if the instrument is accurate, the tool will cut a small dot. The height of centre must also be studied, and the tool adjusted precisely to it by the elevating ring of the slide-rest, it must also be set to the same point laterally; by these adjustments the ellipse cutter is precisely in the centre of the material to be decorated.

As an example of simple patterns and adjustments, to place a series of ellipses of equal proportion, or, in other words, concentric, the eccentric cutter may be moved, say, eight divisions of its micrometer, while the flange is moved four divisions of its scale; and to place the separate cuts in equal proportion, the movements of each must coincide.

To produce a pattern in which the ellipses all lay parallel, the eccentricity of the flange remains stationary, while that of the eccentric cutter is reduced in equal ratio for each cut. Another effective pattern is one in which the straight line is first cut and the proportions gradually reduced until a circle is the result. To effect this, the eccentric cutter *K* and the flange *D* are both equally extended, as to eccentricity,

to cut the straight line; the cutter *K* then remains unaltered, while the flange *D* is reduced for each consecutive cut until the zero coincides with the reading line, when the tool will again cut a circle equal to its eccentricity.

The three foregoing examples explain how the instrument is to be employed for simple ellipses, but as the more complex patterns are approached, it will be found necessary to employ the worm-wheel and tangent-screw to adjust the various cuts to the required positions. The worm-wheel having 150 teeth, the micrometer on the screw being divided into four, and one turn moving it through the space of one tooth, it will require thirty-seven and a half turns to place two ellipses at right angles, but that number of turns must be calculated from the division at which the wheel may stand when it has been moved to compensate for any extension of the flange *D* for the first cut. To place three ellipses equidistantly, it will require twenty-five turns of the screw for each, and, by calculation, any number of ellipses may be thus placed equally round the work.

So far, the instrument has only been regarded as to its powers of cutting ellipses of any proportion between the straight line and circle; its powers, however, are largely extended by the introduction of extra wheels of 24 and 48 teeth. These two wheels replace the 24 and 36 on the stud, and that on the stem of

the eccentric cutter has substituted for it one of 24 teeth in place of that having 36. To make this alteration, the screw *c* is removed from the stud, and the milled-head screw taken out, the flange is then withdrawn from the face, the 24 wheel is fixed to the eccentric cutter, the 24 and 48 placed on the stud, and the flange replaced; the wheel of 48 teeth attached to the spindle running through the stem is not changed. The screw *F* need not be removed from the nut, as the fitting by which it is held to the flange being circular, it can be drawn off the nut without the least difficulty. This train of wheels is thus 48—24, which causes the eccentric cutter to revolve four times to one rotation of the pulley, thus creating a four-looped figure. The various ratios between the two points, that is, the flange and tool, with regard to these eccentricities, of course alter the character of the figure to a large or small degree, according to the movement of either, or both.

As an example of the difference to be obtained, we will once more set the instrument all at centre, and if from this point the flange and eccentric cutter are extended a like distance, the loops will touch at the centre, and the result will be that the four will each resemble an egg in shape, the curves decreasing in width towards the centre. If the eccentricity of the flange alone be increased, it will be seen at once that

the figure is entirely different, resulting in an open cusped figure with looped extremities; the amount of open space in each loop depending upon the variation in the eccentricity given to the flange, which may be made to eventually result in a square; the radius of the tool also varies the shape of the figure.

The above explains the result of extended eccentricity to the flange only; now, to effect another variation, if the movement of the tool as to eccentricity be increased beyond that of the flange, the course of the loops will be round the centre, leaving a figured space at that part, the amount of curve left in the centre of the different figures resulting from the ratios of the two settings.

It will be found necessary to resort to the worm-wheel and tangent-screw at the back, to correct the angularity of the figures, that is, where each successive cut requires an increase of eccentricity to the flange, and supposing that a series of loops is to be placed on the work, eccentric to the axis, the instrument receives lateral adjustment from the main screw of the slide-rest, by which means the figures may be placed any distance from the centre.

The figure itself may be multiplied by varying the position of the tool with the worm-wheel; if, for instance, it is desired to have two four-looped figures so placed as to represent eight loops all equidistantly

apart; the first cut having been made, the worm-wheel at the back must be moved by eighteen and three-quarter turns of the tangent-screw, the same proportionate movement of the screw being necessary for increased numbers, the adjustment, as in the previous instance, being calculated from the point at which the wheel stands after the figure has been adjusted to the vertical position. A still further improvement is made to this instrument by the addition of a second radial arm, which is fitted over the circular boss of the flange, and has a curved slot concentric to it, through which a screw fixes it to the face of the flange. This again carries two wheels attached to it, revolving on pivots, so that either or both may be employed to produce the figures in either direction—that is, inwards or outwards. To engage with this arrangement, a small wheel of 18 teeth is placed upon the end of the eccentric cutter, the 48 wheel on the centre spindle still remaining unchanged.

CHAPTER XV.

THE EPICYCLOIDAL CUTTER.

THIS instrument (Fig. 182) may be considered an extension of the ellipse cutter, with additions that

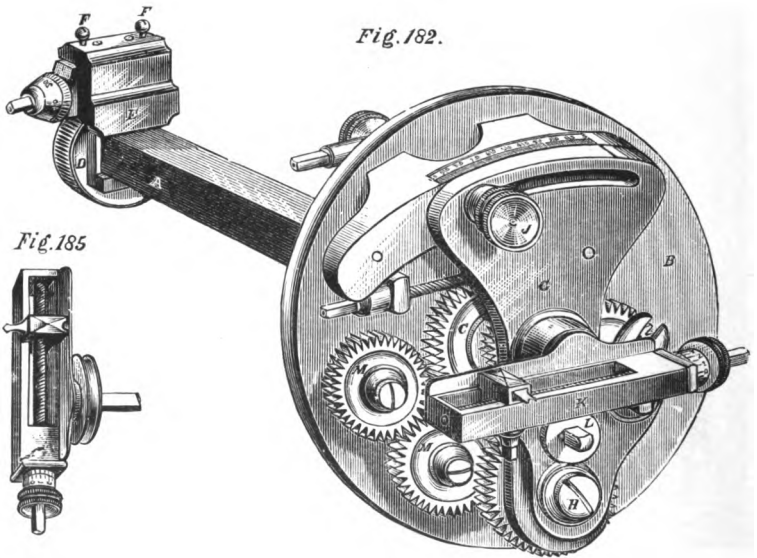

render it capable of producing a very large number of different patterns. It represents, in point of fact,

the first part of a small geometric chuck, mounted on the slide-rest instead of on the mandrel-nose, and although very similar to Fig. 181, its construction in many respects differs. The diameter of the driving-pulley, the groove of which is turned on the edge of the plate B, is $5\frac{3}{4}$ in. in diameter, the increase in size admitting of a larger number of change wheels being employed. A considerable advantage is found in all the necessary changes of the trains of wheels being confined to one arbor only, which is easily removed, and does not necessitate the partial taking apart of the instrument each time different wheels are required. The ability to introduce a greater number of wheels, and consequent variations in ratios, gives a largely increased range of loops, both consecutive and circulating, the former ranging from 2 to 6, that is, 2, 3, 4, 5, 6, emanating from the number of revolutions of the eccentric cutter in proportion to the rotation of the pulley, while the latter are to be obtained from 5 to 90 by delaying the rotation of the eccentric cutter, and introducing to the train of wheels a fractional value. With this instrument all figures may have their loops turned inwards or outwards, but require compensating, which is effected by the worm-wheel and tangent-screw at the back, the same as in the ellipse cutter, with the exception that the wheel has 96 instead of 150 teeth. The amount of

compensation required will depend entirely upon the relative movements and ratios of the eccentric cutter and flange. The details which follow will render the manipulation of this instrument comparatively easy.

The square stem A is fitted to the tool-box of the slide-rest, and has a round end upon which the driving-pulley B revolves, the metal being bushed with a hardened steel collar; through the square stem a spindle is fitted, having fixed to the front end a wheel, C, of 64 teeth; on the opposite extremity, the worm-wheel D of 96 teeth is attached by a hexagonal hole and a screw in the end, a metal upright, E, is also fixed to the square stem, to hold the frame in which the tangent-screw works; on the top of the frame two set screws F F are fitted, to more accurately adjust the movement; the micrometer of the screw is then divided into fifty equal parts, and figured at every ten, by which the wheel may be subdivided into the numbers required.

On the face of the plate B a stud is fixed at the lower extremity as the instrument stands vertically in the tool-box, at the opposite side a block of metal is attached to the same plate; a metal flange, G, is then fitted, one end to the upper part of the stud, the opposite resting upon the block of metal before referred to; this is fixed by a screw in the stud H, and a milled-head screw, J, passing through a curved

slot in the flange; when this is so far fitted the instrument should be mounted on a block, as recommended for Fig. 181, and the centre of the flange turned out perfectly true to receive a steel collar. In this the stem of the eccentric cutter *K* is fitted, and on the end that passes through the flange a wheel of 40 teeth is securely attached by a screw and steady-pin; this wheel, unlike that fixed in a similar way to the stem of the ellipse cutter, never requires to be moved, but remains constant.

To the stud under the screw *H* two wheels are fitted to revolve on a socket, in which is a steel collar. These have 60 and 32 teeth respectively, the latter being on the lower end near the face of the plate *B*, and in the same plane as the 64 wheel attached to the spindle in the centre of the stem *A*; the two wheels are fixed together, and of course revolve simultaneously. Above the surface of the flange *G*, and fitting over the end of the stud *H*, a steel radial arm with a mortise (open at the end) is attached, and partially rotates, being fixed when required by a screw, *L*, which passes through a short semi-circular slot, allowing sufficient movement to admit of any of the changes of wheels passing into gear.

To the radial mortise in this arm a removable arbor is fitted, to slide throughout its length, and in this again a spindle revolves to carry the change wheels,

two of which are always attached to it by a circular milled-head nut. This arbor is so arranged that the upper wheel gears with the 40 on the end of the eccentric cutter, while the lower one performs the same office with the upper wheel of the two on the stud H, which has 60 teeth, and until the removable arbor is interposed, there is no connection between the wheel on the stud and that on the eccentric cutter; and provided two wheels of the same number are employed to make the connection, the value of the train remains the same, and will produce a three-looped figure, the tool in the eccentric cutter rotating three times for one complete revolution of the plate or pulley, and the various wheels employed on the removable arbor multiply or divide the initial value of the permanent train of wheels, which is: 64—60

32—40

To alter the wheels on the arbor, the screw is loosened by the key and the arbor withdrawn; the screw that binds the arm to the flange is also slackened, and, when the wheels are changed, the arbor is returned and the wheels geared by the lateral adjustment in the radial slot, and the semi-rotation of the arm, both screws being then retightened. The 64 wheel on the spindle through the stem, and the 32 on the lower portion of the socket that revolves upon the stud, are connected by two carrier

wheels, *M M*, which are attached to the plate *B*, by screws from the back, the plain part which goes through the plate moving freely in a hole larger than itself, so that each one may be thrown in or out of gear as required. Under the screw-head a washer is placed to cover the hole, and to more readily clamp the stud upon which the wheels revolve.

The object of these two wheels is to change the direction of the figures; for instance, if both are employed at the same time, we have an even number of axes at work, which causes the loops of the figure to turn inwards, while if one only is geared, the result is that the loops turn outwards. The carrier wheels do not alter the value of the train in any way, but simply afford the means of changing the direction in which the tool traverses.

The eccentric cutter is fitted up in precisely the same way as for Fig. 181. The edge of the block is divided to a scale of 100 divisions, read by a line marked on the flange *G*; and the means of adjusting the flange by a screw of ten threads to the inch is also fitted in the same way as that on the ellipse cutter, so that equal movements of the tool and flange result in corresponding eccentricities to both. The worm-wheel and tangent-screw for the compensation of the angular aberration of the figures is in all respects the same as in Fig. 181, with the exception, as before

mentioned, that the wheel has 96 teeth in place of 150.

In order that the figures to be produced may be in a vertical position, it is necessary that the flange should stand horizontally when the wheel on the removable arbor is geared with that fixed to the eccentric cutter, the latter being then in the vertical position, and the division on the flange being set also at its zero. To regain this position, two lines are marked, one on the cylinder boss at the back of the pulley, the other, which represents the reading line, upon the edge of the circular flange of the stem, against which the fitting of the pulley revolves. When these two lines are coincident, the above adjustments are made.

The epicycloidal cutter, as already described, produces many very beautiful figures of a fine-line description, the beauty of which is really more advantageously seen when printed, and although the variety of patterns to be produced is practically endless, the particular description of work to which it is confined greatly detracts from its value; and it was after a long series of experiments with the instrument that the author arrived at the conclusion that its merits would be very much enhanced by the introduction of a means of cutting the patterns deeply into the surface of the work, and removing the superfluous material, thus leaving the figure in relief upon the surface.

To effect the above result, it is of course necessary that the combined motions of the instrument travel precisely the same course, but at a very slow speed. This is provided by the addition of the worm-wheel A, Fig. 183, which is fixed to the short-cylinder body

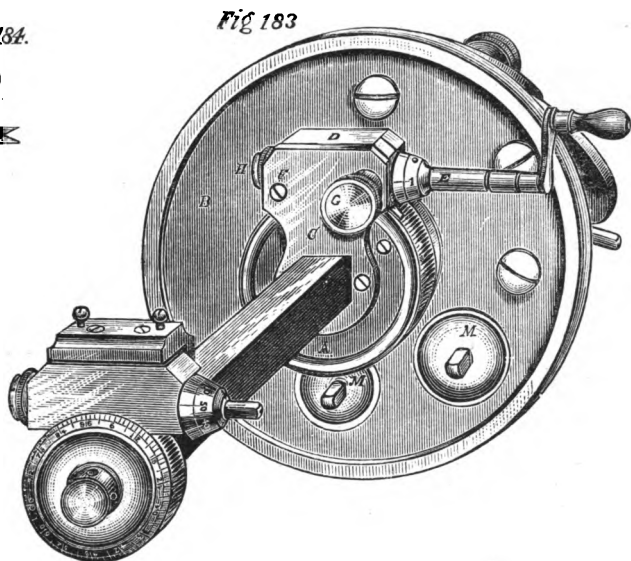

at the back of the plate B. This wheel has 140 teeth cut on its periphery, the edge of it being divided, to note its partial rotation. A plate of steel, C, is then fitted to the square stem, and attached to the face of its flange, also by two screws. This plate, it will be seen, extends upwards high enough to admit

of the frame D, which carries the tangent-screw E, being held to it by a screw, F, which forms the axis upon which it moves. A milled-head thumb-screw, G, passes through a short-curved mortise in the steel plate, described from the axis of the screw F, and is tapped into the frame D, which is cut away in the centre to receive the tangent screw E; the latter is supported at the opposite end by a centre screw, H, and shouldered in at the front end, the face being chamfered to receive the divisions to act as a micrometer, the end being squared to receive a winch-handle, and the division read by a line on the frame D. The micrometer is divided into four equal parts, figured 0, 1, 2, 3.

With this arrangement it will be seen that the motion of the two parallel movements is not in any way influenced with regard to their value one to the other, but the speed at which they move is placed entirely under the control of the operator by the winch-handle J, so that a slow, continuous traverse or a series of partial rotations may be made to suit the work to be decorated. So far we have the means of controlling the revolution of the instrument, and by reference to the following description of the small drilling instrument, Fig. 184, it will be seen that the power of deep cutting is also supplied.

This little instrument, which is fitted to the

tool-box of the eccentric cutter κ (Fig. 182), is made so that its axis agrees with that of the instrument, when set all at centre. On the front of the stem a short cylinder, with a cone at the back, is turned perfectly true, and hardened; this is necessary from the high speed at which it revolves. To this is fitted a steel pulley, retained in its place by a screw countersunk into the stem; to the front of the pulley a steel nozzle is fitted, so that it can be detached, and in this a small taper-hole is bored to receive the drills, which may be made of many patterns, similar to those used in the ordinary drill-spindle. The drills should all be turned in their place to ensure accuracy, which is a most important point.

When used, the drill is driven from the overhead motion at a high speed, which is easily obtained, in consequence of the minute diameter of its pulley. The penetration of the tool is decided in the same way as for other works, by the depth and stop-screws, and the movement of the instrument for the looped figure governed by the winch-handle.

One of the difficulties that at first stood in the way of the progress of this introduction was the inability, with the old style of overhead motion, Fig. 10, to follow the course of the instrument as it carries the drill from point to point through a looped figure, its position being continually altered, as more or less

eccentricity is given to either the flange or the eccentric cutter; and the same objection applied to it as when used in the rose cutter, which will be explained in the following chapter. This was overcome in a great measure by employing a flexible band, but this, although it was found to answer fairly well, had its disadvantages.

Many leading amateurs at once decided to have the improved overhead motion (Fig. 11) fitted to their lathes, by which the drill under notice, and all other instruments (that do not require a rise and fall), are more evenly and smoothly rotated, without the continued changing of the band.

A further addition, emanating from the same source, will be readily seen by reference to Fig. 185. This is a miniature eccentric cutter, fitted at the stem in precisely the same way as the drill (Fig. 184). Attached to the front of the pulley is the slide by which the eccentricity is obtained, its axis being also coincident with the instrument. By the use of this addition the variety of patterns may be largely increased, as it affords the opportunity of cutting a second figure over the course already traced by the action of the instrument.

For a variety of figures composed of consecutive cuts, the worm-wheel (Fig. 183) forms the means of dividing the work, as it is by this, in conjunction with

the tangent-screw and micrometer, that it is equally spaced out. The drill may be usefully employed to place a series of beads or pearls throughout the looped figures ; such patterns, however, may be said to apply to figures of consecutive loops only, for the reason that, when the higher numbers of circulating loops are approached, the pattern becomes mixed up and the effect marred.

CHAPTER XVI.

THE ROSE CUTTER.

THIS instrument, as illustrated by Fig. 186, produces on a limited scale similar patterns to those emanating from the rose engine, and the latter may now be said to be quite out of fashion, being very seldom made, except for trade purposes, and then in a plain form only. It will be seen that the instrument under notice receives a rotary and oscillating motion at the same time, while the work is held stationary by the index, the various adjustments being made, in the radius of the tool, the lateral traverse of the slide-rest, and the movement of the worm-wheel D attached to the disc, upon which the rosette is fixed. With the rose engine the same movements occur to the apparatus fitted to the mandrel and head-stock, which rocks on centres, while the tool is stationary in the slide-rest. The number of patterns to be cut on the face are practically endless, and, by various combinations, may be made very beautiful indeed. Those illustrated, however, are only for the purpose of more fully explaining the movements of the instrument,

which, like its predecessors, will be more easily understood by the details of its manufacture.

The square stem *A* is made to fit the tool receptacle of the slide-rest, and is provided with a plain circular fitting with a flange. Through the entire length a steel

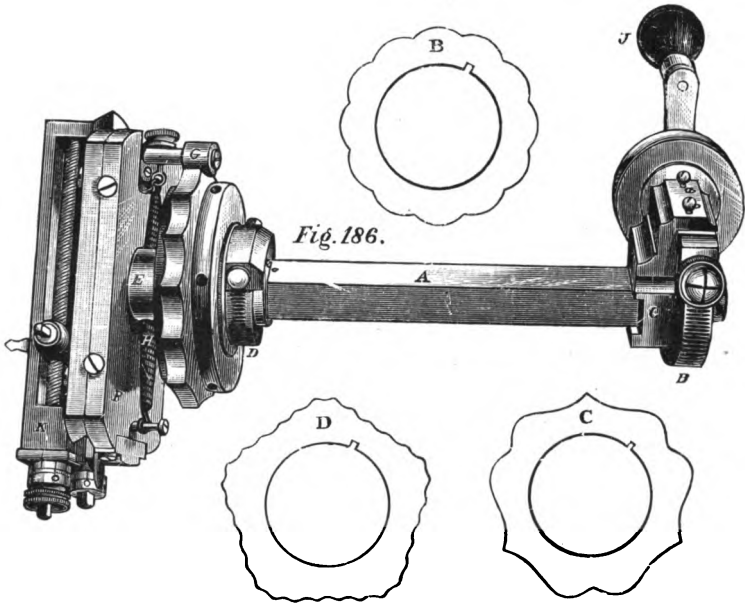

spindle passes, fitting a slightly taper hole in the stem *A*; on the rear end of this spindle a worm-wheel, *B*, is fixed, actuated by a tangent-screw working in a metal frame fixed to the support *C* on the end of the stem. A pulley is fitted to the tangent-screw for the purpose

of driving it from the overhead motion, whereby the instrument is set in motion. On the front, or opposite extremity of the stem, a circular disc is fitted, to which the rosette is fixed by a circular ring or nut, with lever holes in the edge. In order that the necessary changes may be made, the centre aperture in the rosette is made just large enough to pass over the frame and pulley at the other end. To this disc is attached a worm-wheel, D, of 96 teeth, and a tangent-screw to move it in both directions, so that the undulations in the figure may be placed as desired; the disc revolves between the face of the flange on the stem and that of the collar E, which is part of the spindle that passes through the stem, and to which the worm-wheel and tangent-screw at the back are fixed. To the face of this collar a gun-metal oblong plate, F, is securely fixed by a strong screw and steady-pin; to this plate is fitted a steel slide, K, to work at right angles to the stem, between two chamfered side bars; this slide carries a steel tool-box similar to that in the eccentric cutter, and is actuated by a main screw of ten threads to the inch to correspond with all others of a like nature, the micrometer being divided also in the same way. The slide, it will be seen, is made the entire length of the plate, and the tool by this means can be placed on either side of the axis of the stem, in the same diametrical line. To obtain the oscillating motion necessary to the slide, the end of the plate F has a slot

cut in it, and to the slide a steel post is fixed, upon which a small steel roller revolves. This, when in use, is kept in contact with the rosette by a strong spring, H, attached to a screw in the metal plate F at one end, and through the pillar that carries the roller at the other, a small milled nut is fitted on the end of the spring, by which the tension is altered; the spring passes freely through a hole in the centre of the collar E. By this it will be seen that as the roller passes round the rosette it is always in contact with it, and the tool traces the figure on the work.

At the end of the plate F, opposite to that on which the pillar holding the roller is fixed, a steel stop-screw is fitted to a projection, also fixed to the same plate; this is used to prevent the roller from following the full depth of the figure contained in the rosette. It is also employed to keep the roller from coming into contact with the rosette in any way, in which case the tool describes a circle only, the diameter being determined by the radius given to the tool.

This instrument, like the epicycloidal cutter, also receives the small drilling instrument (Fig. 184), and when this is employed the movement of the roller round the rosette is controlled by the winch-handle on the tangent-screw of the worm-wheel. The miniature eccentric cutter (Fig. 185) is also applicable, and renders some very beautiful work, as the patterns emanating



Fig. 187.

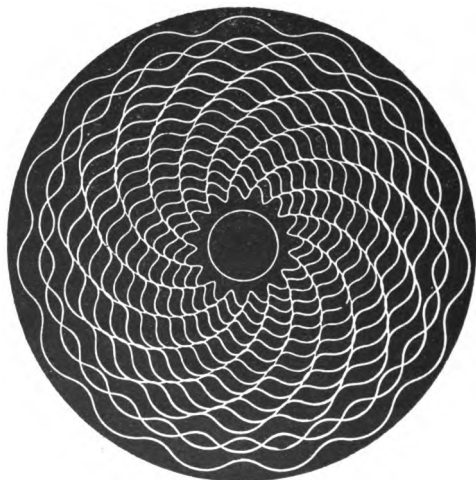

Fig. 188.

from its introduction may be carried out entirely through the form of the rosette employed, which adds so much to the effect of this style of decoration.

The manipulation of the rose cutter is by no means a difficult process, as will be seen by the following examples. Fig. 187 is the result of employing the rosette B. The roller is first moved by the stop-screw, so that a circle only is described by its revolution, and the slide-rest adjusted laterally till the axis of the instrument is perfectly true to that of the work on which the pattern is to be cut; the stop-screw is then withdrawn, in order that the roller may take effect on the undulations of the rosette; the tool is then set to a radius of $\frac{11}{10}$, that is, eleven turns of the main screw of the right-angle slide, by which the tool is carried towards the micrometer of the slide; the penetration is then adjusted by the stop-screw of the top slide, to cut a fine line, the tool being a double angle of 45° ; the instrument is then set in motion by the pulley on the tangent-screw at the rear end, a slow speed being in most cases necessary. The result of this rosette is as seen throughout the different patterns cut on Fig. 187, the simple waved line nearest the margin being produced by the adjustment referred to.

The eccentricity of the tool is reduced by one turn, and the same form again traced. The result of the two lines seen in the second pattern is for the purpose of

explaining the use of the worm-wheel D, attached to the disc on which the rosette is fixed. Having cut the first line, the rosette is moved by the tangent-screw, so that the second line crosses the centre of the first, and this may be divided into many parts for various patterns. This will be referred to again; at present, the two lines are quite a primary example of the manner in which it is used.

By reducing the radius of the tool one turn more, the same figure is again cut, while by a further reduction of one half turn, or $\frac{5}{100}$ in., for each consecutive cut, the six following are equi-distantly placed, gradually decreasing in diameter and width of wave. From this point a different movement is added to the adjustments, by which the pattern is carried out in the same way, as for similar results in plain circles, cut by the eccentric cutter. The tool is again reduced in radius by one half turn, and moved laterally by the main screw of the slide-rest a corresponding distance—namely, one half turn; by repeating these movements nine times, a shell composed of waved lines is the result. It will be seen that as each cut nears the centre the figure becomes more pointed. This is not from any additional movement, but simply from the gradual diminution in the diameter.

Fig. 188 is produced by employing what may be termed the opposite rosette to that used for the previous

example, inasmuch as the curves cut are all convex instead of concave; the instrument is adjusted as before to agree with the periphery of the work, the tool set out to a radius of $\frac{1}{10}$, and the first cut made. This gives simply the result of the combined motions round this particular description of rosette. For the two next cuts the tool is reduced in radius by one turn of the screw, and the same penetration inserted; the rosette is then moved by two turns of the tangent-screw of worm-wheel D attached to the disc, and the second cut made. By this it will be seen that the pattern crosses in the same way as the second series in Fig 187.

The inner pattern illustrates an additional movement, by which the pattern is twisted. To produce this, the following adjustments are necessary: For the first cut the radius of the tool is again reduced by one turn, for the second the radius is further reduced by one half turn of the screw, and one and a half turns of the tangent-screw of the worm-wheel D, these movements being precisely the same for each succeeding cut. The patterns may be reversed by moving the tangent-screw in the opposite direction.

Fig. 189. This example is produced by employing the same rosette, as the line nearest the margin will show. The succeeding cut, however, illustrates the use of the stop-screw. Having reduced the radius of the tool by one turn of the main screw, the stop-screw is

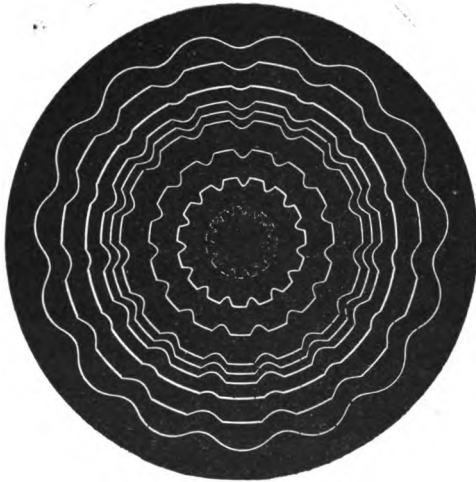

Fig. 189.



Fig. 190.

brought to bear lightly upon the slide, and then moved forward one turn. The effect of this is to prevent the roller reaching the lowest part of the undulation in the rosette, by which the true form of the latter is destroyed, and a portion of the figure becomes a part of a concentric circle only, the curves resulting from that part of the rosette which touches the roller in its rotation. This process is repeated throughout the rest of the pattern, and it will be seen that, as the centre is approached, the figure gradually decreases in proportion.

Fig. 190 portrays the form of the rosette *c*; the adjustment of the instrument as to centre is the same, the marginal line being simply the result of the figure; the second series is produced by the reduction of the radius of the tool for the first cut; for the second the worm-wheel *D* is moved by two turns of the tangent-screw, while for the third the same amount is necessary; by this the pattern is crossed. The inner pattern is produced from the same rosette, each consecutive cut being made one half turn of the screw nearer the centre; the concentric circle is cut perfectly true to the figure by reducing the radius to the diameter required, and by the stop-screw being moved forward so that the roller will not touch the rosette.

Fig. 191 illustrates the application of the rosette *D*; the movements of the tool being similar to those for the preceding figures.



Fig. 191.

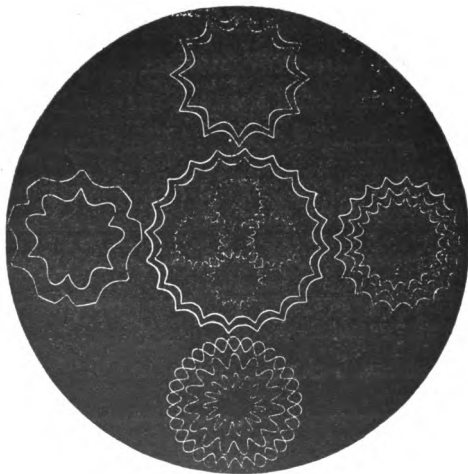

Fig. 192.

Fig. 192. By this example we arrive at the means of placing the various figures to be obtained by the rose cutter eccentric to the axis of the work. These may be varied to a very large extent, and by employing either of the ornamental chucks may be placed in almost any position that can be desired as to distance from the axis of the work; the pulley is then held stationary at the four quadrants of the circle. The four patterns are all produced from different rosettes, the radius of the tool being adjusted to the diameter required, and the instrument moved by the slide-rest screw, so that each pattern may be contained within the space.

The author wishes it to be clearly understood that the foregoing examples are not illustrated as figures of beauty, but simply to show clearly the manner in which the instrument is manipulated, and for such purposes the least complicated are most appreciable.

THE END.

*PARTICULARS OF MR.
GUILBERT PITMAN'S
LATEST TECHNICAL
PUBLICATIONS WILL
BE FOUND OVERLEAF.*

BOTTONE'S AMATEUR ELECTRICIAN'S WORKSHOP. BOOK I.

Illustrated by 30 carefully prepared diagrams.

Cloth, 1/6 net; Post free, 1/8.

A Handbook of Practical Instruction in the making of Electrical Models and Appliances.

CONTENTS.

How to Make an Electro-Motor—The Making-up of Lalande-Chaperon and Chromic Acid Batteries—The Construction of a One-Inch Ruhmkorff Spark Coil—How to Make a Wireless Telegraph—How to Use a Wireless Telegraph—Sparking Coils for Motors: How to Make and Repair.

WHAT THE PRESS SAYS:

"Well worthy of a place in the library of the amateur."—*Westminster Gazette*;

"Gives the minutest directions as to the way to set about making an Electric Motor, Wireless Telegraph, etc., etc."—*Daily Graphic*.

"Capital; . . . quite up to the author's high standard."—*Literary World*.

"A wonderful amount of practical information."—*Electricity*.

"Will be found most useful."—*Daily News*.

"Valuable advice."—*Liverpool Mercury*.

"Details for making a Wireless Telegraph are clearly set forth."—*Ironmonger*.

"The instructions have the commanding merit of practicability."—*Mechanical World*.

"A practical little illustrated book."—*The Times*.

"Practical, smart, well illustrated, and clearly written."—*Scotsman*.

"Sure to be welcomed."—*Morning Post*.

"Noteworthy for the simplicity and clearness of its guidance."—*Standard*.

"Illustrated and practical."—*St. James's Gazette*.

"Should be a big demand for it."—*Birmingham Gazette*.

"The instructions are such that any novice could, with reasonable care, make the various items of apparatus described."—*Model Engineer*.

GUILBERT PITMAN, 86 & 87, Fleet Street, E.C.

JUST PUBLISHED.

PRACTICAL KITES AND AËROPLANES :

How to Make and Work Them.

Illustrated by Forty-three Carefully Prepared Diagrams.

Cloth, 1/6 net; Post free, 1/8.

By **FREDERICK WALKER, C.E.**

Fellow of the Society of Patent Agents, Associate Member of the
Aëronautic Institute.

A Practical Work on the Construction and Use
of Kites and Aëroplanes, with special con-
sideration of the best mode of constructing
kites for ascertaining the state of the upper
atmosphere, photographing, wireless and
luminous signalling, and, for those possess-
ing sufficient confidence, aërial flight or
aërial traction.

GUILBERT PITMAN, 86 & 87, Fleet Street, E.C.

LUKIN'S POSSIBILITIES OF SMALL LATHES.

A thoroughly practical and up-to-date treatise
upon modern Lathes of small dimensions.

Profusely Illustrated. Cloth, 1/6 net; Post free, 1/8.

SYNOPSIS OF CONTENTS.

The Cheap £10 Lathe; Examples of a few Simple Articles; Designing; Home-made Tools; Ovals or Ellipses for Small Frames; Spiral Work; Square and Triangular Pedestals; Swinging or Balanced Overhead; Details and Further Particulars of Overhead; Cone Plate or Boring Collar; Pipe Chucks; Screw Chasing; Dumbleton's Apparatus; Ornamental Drilling; Metal Work; Chucks; Home-made Chucks and Drills; New Forms of Home-made Overhead; Principle of Cutting-Tools; Cutter-Bars; Gauges, Squares, and other Measuring Instruments; Simple Lessons in Turning.

PRESS OPINIONS.

"There must be many amateur users of small lathes to whom this little book will bring some pleasant surprises."—*Manchester Guardian*.

"Well-written, useful, and intensely interesting."—*Midland Herald*.

"Contains plenty of practical hints."—*American Machinist*.

"Mr. Lukin has a thorough understanding of his subject, and is happy in conveying his knowledge to others."—*Sheffield Daily Independent*.

"This is a handy little book of absorbing interest to the amateur mechanic. Valuable hints are given regarding ornamental turning in wood and metals, on drills and drilling, and the making of tools. It is a most useful book."—*Newcastle Daily Leader*.

"The subject is very attractively treated, and forms a most interesting revelation of the astonishing capabilities of a simple lathe. The book, moreover, is not marred by too technical descriptions, and is illustrated by nearly 100 pictures."—*Blackburn Telegraph*.

"The author is a well-known amateur mechanic, and his instructions are always thoroughly practical. The book is an excellent one, and will appeal to many of our readers."—*Scientific American*.

"Those of our members who incline to mechanical pursuits will be interested in this little book, which that enterprising publisher, Mr. Guilbert Pitman, has just issued. He refutes the idea that small lathes are useless toys, and gives many examples of work which may be done by a small machine."—*People's Journal (Dundee)*.

GUILBERT PITMAN, 86 & 87, Fleet Street, E.C.

BOTTONE'S IGNITION DEVICES

FOR GAS AND PETROL MOTORS.

WITH

A Chapter treating specially of
Structural Details, Choice, and Management
of Automobiles.

FULLY ILLUSTRATED.

Cloth, 2/6 net ; Post free, 2/8.

COMMENDATIONS FROM WELL-KNOWN PAPERS:

"This little handbook will be found invaluable to all amateur electricians and automobilists interested in spark coils and their workings, as well as in the other parts of an electric ignition system. The Author is a practical man of experience. One of the most interesting descriptions in the book is that of a combination jump spark coil and dynamo of his own invention. Instructions are given for making both primary and secondary spark coils. The theory of their working is also clearly explained. An introductory chapter on the automobile is of considerable interest."—*Scientific American*.

"Mr. S. R. Bottone's little volume on 'Ignition Devices for Gas and Petrol Motors' will be found very interesting to the amateur who is intelligent enough to wish to know something about the engine which drives his launch, his motor-car, or his bicycle. The preliminary section is devoted to a useful disquisition on the choice and management of automobiles, with well-arranged information as to their structural details. This chapter is alone worth the half-crown demanded for this book."—*Westminster Gazette*.

"Of such a character as to make the work almost indispensable."—*Manchester Courier*.

"Another book that should be added to the library."—*Review of Reviews*.

GUILBERT PITMAN, 86 & 87, Fleet Street, E.C.

TENTH THOUSAND.

SYSTEMATIC MEMORY ;

or, How to Make a Bad Memory Good, and a
Good Memory Better.

By T. MACLAREN.

ENLARGED AND IMPROVED EDITION.

Complaints are continually heard about bad memories. Some have the misfortune of having been born with "shocking bad" memories ; while others have, in their early years, been gifted with wonderfully good memories, but, by some mysterious process, have gradually lost the power of retaining even the most recent facts. Some, again, have the rare faculty of at once, and without the slightest difficulty, committing to memory everything they please, but, unfortunately, in a very few days all is entirely forgotten ; others, on the contrary, have very great difficulty in fixing anything in their minds ; but when once a thing is fixed, it is fixed for ever. The truth is, that most persons do not know how to employ their memories. The faculty may be tolerably good, but the power of application is too frequently wanting. The system set forth in this remarkable work is intended to make bad memories good, and good memories better.

Parents will do well to encourage their children to learn this science, which is indisputably one of the highest practical value.

Students about to go up for examination will find the system of peculiar assistance to them.

Price 1/- (net) Cloth.

GUILBERT PITMAN, 86 & 87, Fleet Street, E.C

ENGINEERING WORLD

And Amateur Carpenter and Electrician.

2d. Monthly.

Principal Contents :

No. 1.

Lathe Work for Young Engineers.
(Continued in subsequent Numbers.)

Practical Electrical Engineering.
(Continued in subsequent Numbers.)

All about Primary Batteries.
(Continued in Nos. 2 and 3.)

A Design for an Artistic Wash-stand. Etc.

No. 2.

Shelves, and How to Fix them.

Home-made Device for Decorating Glass.

How to construct a Model Railway Track.

Locking Gate by Electricity. Etc.

No. 3.

How to Make a Small Water-Motor.
A Dwarf Bookcase and its Construction.

How to Make a Dynamo.

Proportions for 15-kilowatt Dynamo. Etc.

No. 4.

A Sideboard of Simple Construction.

How to Cure a Draughty Window.

How to Make a Wimshurst Electrical Machine.
(Continued in Nos. 5 and 6.)

How to Find a Fault on Telephonic Apparatus.

Reversing Gear for Electric Motor. Etc.

No. 5.

A New Soot-Proof Plug for Gasoline Motors.

An Inexpensive Overmantel for the Dining-Room.

How to Build an Electric Despatch Boat.
(Continued in Nos. 7, 9, and 11.)

Speed of Pulleys. Etc.

No. 6.

A Model Hopper-Bottom Railway Wagon.
(Continued in Nos. 7, 9, and 11.)

Practical Kites and Aeroplanes: How to Make and Work Them.
(Continued in Nos. 8, 9, 10, and 12.)

Electric Trams.

Proportions for a 12-inch Spark Coil. Etc.

No. 7.

Changes in Motor Windings for different Voltages.

How to Make a Cribbage-Board.

How to Make a Settle or Hall-Seat.

Self-Closing Coal Cabinet. Etc.

No. 8.

Three Simple Electro-magnetic Experiments.

How to Make a Magazine Camera.
(Continued in No. 9.)

Launches, Electric or Steam.

Screen for Fireplace. Etc.

Of all Booksellers and Newsagents, or

GUILBERT PITMAN, 86 & 87, Fleet Street, E.C.

THE Shorthand World

THE LEADING SHORTHAND MAGAZINE,

Edited by GUILBERT PITMAN

(Formerly manager to SIR ISAAC PITMAN, LTD.).

32 pages.

MONTHLY.

4d.

**For Faultless Outlines, Symmetry of Form,
Abundance of Matter, Guidance and Entertainment,
it is without parallel.**

The artistic beauty of the flowing shorthand characters—clear, bold, and legible, and divided into three grades, Easy, Medium, and Advanced—at once excites attention and admiration.

The shorthand matter for the student, contributed by writers of reputation and experience, is full of suggestive and helpful interpretation, while the lighter literature is selected with taste and judgment.

In short, nothing is neglected to maintain the already high standard of usefulness alike for the beginner and the expert.

“Letters that Bring Business,” written in the brief reporting style of shorthand, counted for dictation practice, forms a valuable means for attaining a high speed of writing. The SHORTHAND WORLD grants its Certificates of Competence in Shorthand and Typewriting free of charge.

*A Specimen Copy will be sent, post free, for 4d., from the
Publisher,*

GUILBERT PITMAN, 86 & 87, Fleet Street, E.C.

SINCE 1887,

KENSINGTON COLLEGE

Has held its unique and unbroken
record of having provided a

Satisfactory Appointment for every Student

OF THE

CHAMBER OF COMMERCE CITY COURSE,
AND THE SECRETARIAL TRAINING COURSE.

*Address:—The Secretary, Kensington College,
143, Queen's Road, Hyde Park, W.*

Stanford University Libraries



STANFORD UNIVERSITY LIBRARIES
STANFORD AUXILIARY LIBRARY
STANFORD, CALIFORNIA 94305-6004
(415) 723-9201

All books may be recalled after 7 days

DATE DUE

MAR 21 1998
MAR 14 1998

