

**ORNAMENTAL
TURNING**

J·H·EVANS

Cornell University Library

BOUGHT WITH THE INCOME
FROM THE
SAGE ENDOWMENT FUND
THE GIFT OF
Henry W. Sage
1891

A.1177449

28/4/1904

Cornell University Library

arV19423

v.1-3

Ornamental turning;



3 1924 031 276 433

olin,anx

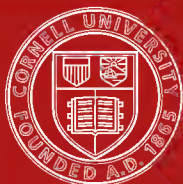

Cornell University Library

The original of this book is in
the Cornell University Library.

There are no known copyright restrictions in
the United States on the use of the text.

ORNAMENTAL TURNING

ORNAMENTAL TURNING

A WORK OF PRACTICAL INSTRUCTION IN
THE ABOVE ART

BY

J. H. EVANS

VOLUME I

WITH NUMEROUS ENGRAVINGS AND PLATES

LONDON

GUILBERT PITMAN

CECIL COURT, ST. MARTIN'S LANE, W.C.

1903

MAY BE HAD THROUGH ALL BOOKSELLERS

PRINTED BY
WILLIAM CLOWES AND SONS, LIMITED,
LONDON AND BECCLES.

[ENTERED AT STATIONERS' HALL.]
(All rights reserved.)

INTRODUCTION.



THE art of decorative turning necessarily embodies many distinct classes of work, which may be applied to either the surface, cylinder, or to the shaping of compound solid forms, polygonal figures, and a variety of other and distinct shapes; the different instruments being applied in combination with almost equal facility for all and any of them.

The decoration of the surface, by various groupings of fine lines, and the intersection of circles together with other curves, has been liberally treated in different works for some years past, and practically leaves little to be said; it has therefore been considered advisable to pass over this particular section, and to at once enter upon the descriptive analysis of the tools and apparatus used for the production of the numerous specimens illustrated.

Although surface decoration has received the advantage of description by so many experienced authors, it is only within the last two years that the art of

decorating compound solid forms has been treated to any extent.

The details connected with the manufacture of the instruments are published at the express wish of many scientific amateurs, who delight more in making tools than applying them to their several uses.

In nearly every case the specimens have been turned by the author himself, but he has much pleasure in expressing his due appreciation of the kindness of many gentlemen who offered to lend any of their work for the purpose of illustration, and to the late Earl of Sefton, Captain R. P. Dawson, and the Rev. C. C. Ellison, he will be ever grateful for the loan of the specimens illustrated by their kind permission.

As this book is devoted to the description and illustration of the modern ornamental turning lathe and apparatus, reference will not be made to such tools and appliances as were available only in the very early period of the lathe's history, and which, although interesting from an historical point of view, are not likely to add to the experience of amateur turners of the present generation.

In conclusion it is scarcely to be anticipated that so large an amount of detail will be absolutely free from slight errors of some kind, and should such be discovered the author will feel grateful for information, in order that they may be corrected in the next edition.

CONTENTS OF FIRST VOLUME.



CHAPTER I.

THE ORNAMENTAL TURNING LATHE.

PAGE

Brief description of its Manufacture—Reference to Screw Guides—Mode of employing them, also the Chasers as used for the purpose of reproducing the Screw on the work—Manner in which the Pulley is put together, the number of Circles of Divisions drilled in the face, and the way they are subdivided and figured—Position of the Index—Description thereof, as made in a plain form—Advantages derived from the Adjusting or Compensating Index—Necessity of drilling the Zeros or starting-points on an arc described from the Index when in its place—Outline of Improved Overhead Motion explaining its advantages—Improvements to Crank-hook	1
--	---

CHAPTER II.

MODE OF CHUCKING AND ADJUSTMENT OF WORK.

Showing the various ways of holding different subjects while operated upon—Reference to American Scroll Chucks—Die Chuck as invented by Mr. Bennett—Boxwood Spring Chucks—The advantage of Metal Chucks of a similar form—Cement employed as a means of chucking special objects—Component parts—The Face Plate as used for holding flat surfaces—The manner in which ivory work is attached by glue and released by immersion in warm water—How to hold materials of large diameters	10
---	----

CHAPTER III.

ADJUSTMENT OF TOOLS, CHUCKS, ETC.

	PAGE
Indicating the manner in which different objects are shaped by hand, or the Slide-rest—To be subsequently decorated by the Revolving Cutters, by which Beads, Pearls, Facets, Reeds, etc., are produced and equi-distantly spaced—The partial rotation of the Mandrel under the guidance of the Worm-wheel and Tangent-screw—Rectilinear and other movements in combination	17

CHAPTER IV.

DIVISION-PLATE AND INDEX.

Description of the Index as made in a plain form, also with the power of adjustment—The importance of the latter arrangement—Its use as a means of sub-dividing the different divisions, if necessary—The manner in which the eight Circles of Division in the face of the Pulley are figured to avoid errors in counting—Detailed description of Automatic Counting Apparatus as invented by T. J. Ashton, Esq.—The advantages derived from its employment—Its Manufacture fully described and illustrated by two views of the Apparatus—Table of Divisions contained in the different circles drilled in the face of the Pulley	19
---	----

CHAPTER V.

THE HEIGHT OF CENTRE OF THE TOOLS.

The importance of extreme accuracy in centering all Tools and Cutters when so required—The means adopted to arrive at a satisfactory result—Showing the different description of centering gauges—The most certain test to employ—The elevation or depression of the Tool by the ring of the Slide-rest, and means of fixing the same	30
---	----

CHAPTER VI.

GRINDING AND SETTING TOOLS.

Reference to Tools having straight or angular edges—The Gonestat, its manufacture, and manner of employing it; improved plate-glass tablet upon which it is worked—The	
--	--

	PAGE
different Slabs used to sharpen the Tools, and cutting powders required—The different Sockets necessary to hold the cutters, drills, etc.—The correct angle to which the cutting edge should be ground—Newly designed instrument, by the Author, for setting the edges of Round-nosed Tools—The necessary Cones, and mode of sharpening Bead and Moulding Tools—The Vertical Grinding Machine—The Horizontal Machine—Description of a Combined Machine, embodying all three on one stand, showing its simplicity and consequent advantages	33

CHAPTER VII.

MATERIALS APPROPRIATE FOR ORNAMENTAL TURNING.

African Black Wood the best of hard woods—Hints as to cutting and preparing the ends to prevent cracking—Cocus being next in texture; King, Zebra, Coromandel, and Cam Woods as suitable for plain turning—Boxwood employed for trials of different work, previous to operating on the more expensive materials—Indian, African, and Green Ivory, their different textures and colour—Mode of preparing them—Selection of Ivory for such works as require several pieces—Small pillars or handles cut from Scrivelloes—Ivory used when cut plain ways	45
---	----

CHAPTER VIII.

POLISHING OF IVORY AND WOOD.

The process of polishing Ivory when left in the form by plain turning—The various patterns left bright from the Tool—The use of the brush with whiting and water—The work dried with boxwood sawdust—Lamb's Wool Pad as used in the grinding machine—Reference to stem of Candelabra, Reeded Columns, etc.—Bees'-wax as applied to blackwood patterns—Hardwood Lacquers and their effects	50
---	----

CHAPTER IX.

OVERHEAD MOTION.

The Overhead Motion as fitted to the Single-bent Arm—Improved plan, with Double Standards, Triangular Bar Sliding	
---	--

	PAGE
Carriage, Tension Bar and Guide Pulleys—Advantages of this arrangement requiring one band only to drive any or all of the different Revolving Cutters, etc., etc.—Its rigidity. freedom from vibration, and adjustment of the Tension	53

CHAPTER X.

THE ORNAMENTAL TURNING SLIDE-REST.

Its early and incomplete form—Its Manufacture—Use of Set Square and Set Bevel, and the objection to their employment—General advance in the design of the Slide-rest, showing its improvement—Fluting Stops and Socket for Spiral Wheels—Bridle to place the Top Slide under control without the use of the Lever—Metal Cradle by which the rest is set parallel or at right angles to the bed, without the necessity of Set Squares—Compound Slide-rest of the latest construction, with all improvements—Self-acting Apparatus for grailing Quadrant to Top Slide—Divided Arc to determine any Angle between the two points—Improved Fluting Stops	58
--	----

CHAPTER XI.

AUTOMATIC STOPS.

Self-acting Slide-rest, with Automatic Stops, invented by T. I. Ashton, Esq. — Description of its Manufacture — Outline engraving of Automatic Stop to Top Slide; its full description—The Metal Turning Slide-rest—Loss of time in the Nut, and the proper way to prevent it—Adjustable Index to Micrometer	72
--	----

CHAPTER XII.

SLIDE-REST TOOLS AND CUTTER-BARS.

The advantage of the latter—The Gouge Cutter-bar—Internal Cutter-bar—Universal Cutter-bar, invented by Mr. Garvin Jones	84
---	----

CHAPTER XIII.

TOOLS APPROPRIATE TO THE ORNAMENTAL SLIDE-REST.

PAGE

Slide-rest Tools and their uses—Newly designed Parting Tools—Socket Handle—Steel Bar to increase the length of the Tool in the Slide-rest—Use of the Slide-rest Tools for various purposes	90
--	----

CHAPTER XIV.

THE ECCENTRIC CUTTER.

Its Manufacture and different applications for the shaping of various forms, such as pillars and surface solids—Plate of examples of its production	100
---	-----

CHAPTER XV.

ECCENTRIC CUTTERS.

The necessary Tools to be used in the Eccentric Cutter—Moulding Tools for deep figures—Improvement in form of Tools—Descriptive analysis of their various uses	113
--	-----

CHAPTER XVI.

THE VERTICAL CUTTER.

The Vertical Cutter—The same as invented by Dr. Stodart—Necessary Tools for the same—Improved Tools with their cutting edges on one side—Description of the way to employ them—Plate of their production	120
--	-----

CHAPTER XVII.

THE HORIZONTAL CUTTER.

Spindle for Circular Cutter, also for Circular Saw—Socket to hold short Tools—Reference to the same Tools, as used in Vertical Cutter—Plate of examples of ornamental subjects produced by the instrument	135
---	-----

CHAPTER XVIII.

A BASKET-WORK CASSET.

	PAGE
Selection and size of suitable material—Method of chucking— Polishing—Necessity of gluing to chuck—Directions for Turning—Mounting Casket	146

CHAPTER XIX.

ELECTROTYPING.

Advantages derived from Electrotyping in Intaglio, and kindred work—Type Metal as a Foundation—Method of securing the Metal Discs—Keeness of cutting edge of Tools essential—Importance of not touching the surface of the disc by hand	158
---	-----

ILLUSTRATIONS OF FIRST VOLUME.



FIG.	PAGE
1. THE ORNAMENTAL LATHE	2
2. AUTOMATIC COUNTING APPARATUS	24
3. AUTOMATIC COUNTING APPARATUS	27
4. THE GONEOSTAT	35
5-7. CUTTERS AND SOCKET	35
8. INSTRUMENT FOR GRINDING CONVEX EDGES	38
9. GRINDING MACHINE	42
10, 11. OVERHEAD MOTIONS	54, 55
12-16. ORNAMENTAL TURNING SLIDE-RESTS	59, 61, 65, 66, 70
17, 17A, 17*. COMPOUND SLIDE-REST AND AUTOMATIC STOP	73, 74, 77
18. METAL TURNING SLIDE-REST	80
19. GOUGE CUTTER-BAR	85
20. CUTTER-BAR FOR BORING DEEP CYLINDERS	85
21-23. CUTTER-BARS FOR METAL TURNING	86, 87, 88
24. UNIVERSAL CUTTER-BAR	88
25-61. TOOLS APPROPRIATE TO THE SLIDE-REST	91, 92, 95, 96
62-64. THE ECCENTRIC CUTTER	101
65-93. ECCENTRIC CUTTERS	114
94-96A. THE VERTICAL CUTTER	121
97-117. TOOLS FOR REVOLVING INSTRUMENTS	133
118, 119. THE HORIZONTAL CUTTER	136
120. A BASKET-WORK CASKET	147

PLATES OF FIRST VOLUME.



PLATE	PAGE
1. EXAMPLES OF WORK EXECUTED BY THE EOCENTRIC CUTTER	103
2. SIMPLE EXAMPLES OF WORK DONE WITH THE VERTICAL CUTTER	125
3. PATTERNS DESCRIPTIVE OF THE USE OF THE HORIZONTAL CUTTER	139
3A. EXAMPLES OF THE ELECTROTYPE PROCESS	163

ORNAMENTAL TURNING.

CHAPTER I.

THE ORNAMENTAL TURNING LATHE.

THE illustration represented by Fig. 1 is a lathe of the most useful description, and the author deems it expedient to give the details of such in the opening chapter, so that amateurs of little or no experience may be able to obtain an idea of the lathe most suitable for their purpose. As the details of the various adjuncts will be fully described in future chapters, the engraving is simply of a lathe of the particular type most suited to the art of ornamental turning.

It is a 5-in. centre lathe with traversing mandrel, which is bored throughout its entire length; and, as all lathes of high-class manufacture should do, runs in hardened steel collars; the mandrel is also perfectly hard. The latter being bored through adds considerably to the convenience of the lathe for many purposes; long rods of steel or other materials, for instance, may be passed

Fig. 1.

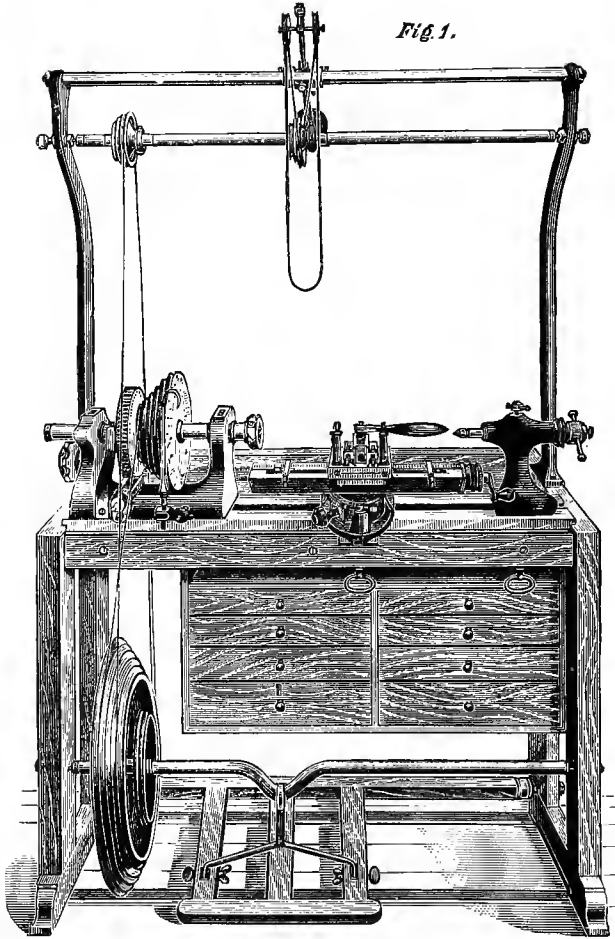

up the aperture while the end projecting from the chuck is turned ; and in the case of a large number of small articles being required, each one may be cut off, and the material withdrawn and again fixed.

On the rear end of the mandrel, steel screw-guides are fitted, of different pitches, six being the usual and sufficient number. These are employed to reproduce the screw on the work, and are actuated by an eccentric, fixed to the headstock immediately under the mandrel. The eccentric carries a metal plate having six arcs, in each of which a thread is cut to match the steel guide ; and when required to be used, the arc is placed in gear with the guide by turning the eccentric round with a lever until sufficient pressure is obtained to allow the mandrel to move backwards and forwards with the necessary freedom, but without shake, while the thread on the guide is reproduced on the work.

The screw may be cut in the first instance with a double-angle point tool (Fig. 26), placed in the slide-rest, or begun and finished with the chasers (Figs. 55 and 56), which are for internal and external threads ; but when the turner is sufficiently experienced, the slide-rest may be dispensed with and the chaser used by hand, fixed in the socket-handle (Fig. 60). In adopting the latter course, the tool is held to the work, and the lathe receives a backward and forward motion by the foot on the treadle so that the pulley rotates the

number of turns necessary to the length of screw required; the tool is released from cut while the lathe turns the reverse way, but again applied directly the return journey commences: this may be easily acquired by practice. When the screw is partly cut, the guide may be removed, and the steel sleeve replaced so that it may be finished by continual revolutions of the lathe while the chaser is under the guidance of the hand. Left-hand screw-guides are equally applicable, but, being seldom required, are not made unless especially ordered.

The driving pulley is made of gun-metal from preference, and is put together in two parts in the following way. The body is turned all over, inside and out, the former being necessary to ensure freedom of superfluous weight at any part; the front is then recessed about $\frac{3}{16}$ in. deep, and undercut to about 4° ; the face is then turned over on both sides, and a corresponding angle turned on the periphery, but the diameter left about $\frac{1}{16}$ in. larger than the recess in the pulley; a hole is turned out in the centre of the plate to pass over the socket which fits over the mandrel. The body is then placed on a hot plate until it expands sufficiently to allow the face to drop in, and when cold the two are firm and immovable. The two angles agreeing, no joint is visible, and this is undoubtedly the proper mode to adopt. Some advocate soldering the faces in, but

this is not to be recommended, and should not be used for high-class work.

On the face of the pulley eight circles of division are drilled—namely, 360, 192, 144, 120, 112, 84, 96, and 12. The zero or starting-point of each circle is drilled on an arc described from the point of the index-peg when in its place, and set about midway on the screw at the lower extremity where the adjustment takes place; by this the index can be raised or depressed. If the zeros are drilled on a radial line it is not possible to move from one circle to another without a readjustment, but when placed on the arc any of the series are available without this. The complete index is seen in its place. (*Vide* Fig. 1.)

There are various ways of fixing the ball that receives the pin of the index, either as seen in the engraving, or it may be fixed at the back, which some prefer; another, and very excellent way, is to have a strong steel pillar fixed at the back, with a hole at the top, into which the pin of the index fits, causing the blade to lay across the top with the peg towards the front of the pulley. This is more convenient in many ways, and, when fitted in this manner, the arc upon which the starting-points are drilled is described by the index when in its place. In this position, also, it is more elevated, and a better light is available.

The popit-head, or back-centre, is fitted with a steel

cylinder and a leading screw of ten threads to the inch, with a drop lever, by which the screw is actuated. The screw is retained in its place by a metal cap, which screws on to the body of the head, and the front of the steel boss through which the lever passes is divided into one hundred equal parts, by which the movement of the cylinder may be read to thousandths. The front of the cylinder is bored out to a taper hole to receive the different centres, and the front of the leading screw is made long enough to eject them when the cylinder is wound in. The advantage of this needs no argument in its favour, when compared with the obsolete plan of being compelled to force the centres out when the screw is not made to operate upon them.

The hand-rest is made in the usual way, and is fitted with tee-rests of different lengths and forms. The boring collar is also a most useful addition, and this also carries a guide for slender turning, which is fixed to the head by a bolt in the same way as the circular cone-plate.

The slide-rest that should accompany such a lathe may be either of those represented by Figs. 13, 14, and 17.

It will be observed that the heads are mounted on cast-iron bearers, which are 3 ft. 6 in. long, and these are fitted to a massive double frame of mahogany, the front of the bed being covered with the same material.

The crank is made of wrought-iron, and the hook, which has two arms, is made of the same. This particular style of fitting up the lower part is an improvement by the author, and it will be at once obvious that, the treadle being supported at both sides, is far superior to the original way of a single hook attached to the centre-rail only. The foot can be placed on any part of the treadle without fear of springing it, and the action altogether is much better. The fly-wheel is of cast-iron (massive), and turned with seven speeds, suitable for quick or slow motion ; underneath the bed is a nest of drawers, in which all the apparatus is fitted, one lock operating on them all.

The overhead motion forms a very important part of the apparatus employed in the art of ornamental turning, and that attached to the lathe (Fig. 1), also illustrated by Fig. 11, whereby it is fully described, is without question the most useful and convenient at present designed, and is now well known as Evans's Improved. It consists of two standards bolted to the frame and connected at the top by a triangular bar, fixed at each end by a nut and washer. Beneath this a steel spindle runs between centre-screws, and carries a pulley and drum, or two grooved pulleys ; the top bar carries a frame which can be moved laterally, and this also holds another frame that works upon centres, and through which a tension-bar slides, having guide-pulleys

at the front, and a counterbalance weight at the other extremity.

A band passes from the fly-wheel to the pulley on the spindle, which has grooves of different diameters, to alter the speed; a second band passes from either the drum or second pulley over the guide-pulleys on the tension-rod, thence to the pulley on the instrument in the slide-rest.

The great advantage in this design of overhead is found in the second band not requiring to be altered, and it is obvious that this is a great boon. In applying it, all that is necessary is to pull down the band until it passes over the pulley of the cutter-frame. The tension required for work of different kinds is altered by moving the counterbalance-weight nearer to or farther from the centre-frame in which the tension-bar slides, the bar itself being also moved in the frame when required. It has been urged against this form of overhead that, in consequence of the guide-pulleys attached to the tension-bar, there is an undue amount of friction; but this exists in theory only, and such a statement is perfectly erroneous; also, that the oil from the guide-pulleys, from the fact of being overhead, is likely to be dispersed over the turner's head; this is also a delusion. If properly lubricated, there is not the least occasion for such a result, as practical experience has clearly proved.

The best evidence the author can put forth in

support of these remarks is that he has now fitted this form of overhead to the lathes of many well-known amateurs—notably, the Earl of Crawford and Balcarres, the Rev. C. C. Ellison, L. V. Lloyd, Esq., T. Hutchinson, Esq., the Hon. Wilfred Brougham, Sir George Pechell, Bart., and very many other distinguished amateur turners—who, one and all, express the greatest satisfaction, and testify to its actual superiority.

CHAPTER II.

MODE OF CHUCKING AND ADJUSTMENT OF WORK.

THE means of holding the material for further operations, commonly known as chucking, is perhaps one of the most difficult branches connected with the art of turning, and one in which more failures occur than in any other, thus disheartening the turner. There are various ways of preparing the rough material previous to chucking it; take, for instance, a piece of boxwood in the rough, about 6 in. long; a small hole should be drilled in the centre to admit the point of the prong-chuck; the wood is then driven on the prong until sufficiently indented to prevent its turning upon the centre; the opposite end is then supported by the popit-head. The next process will be to select a cup-chuck of the most suitable size; the end of the wood should be turned perfectly true both on the face and diameter, and slightly tapered; if the face is not true, it will cause the wood, when driven into the chuck, to be considerably out of truth. The material should never, unless for special purposes which will be referred

to later on, touch the bottom or be driven against a shoulder; it should be held entirely by the circular grip of the chuck. It is not at all necessary to make a deep fitting—about a quarter of an inch is ample for large and heavy work; but it is certain that unless the material is correctly fitted it will never hold in its place while the necessary work is executed upon it, while, if accurately fitted, a much less depth of fitting will answer all the purpose. When fitted, the wood is held in the left hand while the end is struck with a hammer; the chuck should not be placed upon a surface. The author recommends great care in the practice of chucking the work, even in this minor form, as the time so spent will be well repaid in the end. There is nothing more annoying than to find the work moving in the chuck.

The Universal Chuck, with self-centering jaws moved by a right- and left-hand screw simultaneously, is a most useful tool to employ. In the case of materials of large diameters and short lengths, it does away with the necessity for using the popit-head, and at the same time will allow a good deal of work to be done on the face in consequence of the absence of the back-centre. This chuck may also be employed to hold other than circular work; flat substances and uneven materials are held in it while reduced to a state of concentricity. The extreme diameter of the plate,

however, renders it inconvenient for the purposes of ornamental turning, and, where it can be dispensed with for one of less bulk, it is better to do so, and regard it as simply a means of preparing the work for smaller chucks which are more convenient.

The American scroll-chucks, although decried by some, are a very useful addition to a lathe; up to a certain size, and for the purpose for which they are intended, they answer very well indeed.

The old-fashioned die-chuck, with two screws moving independently of each other, may now also be regarded as entirely obsolete. The die-chuck invented by a Mr. Bennett, from whom it takes its name, is a most valuable tool, and supersedes many others in existence. It is illustrated in Fig. 1 on the mandrel-nose.

By the aid of this chuck, articles of different sizes, from less than $\frac{1}{16}$ in. to 1 in. in diameter, can be held not only concentrically but eccentrically. The principle of the chuck is this: it is always true one way, while that part which carries the die is made to slide past each side of the centre by tapping it at either end; and when the work is thus centered, the screw is tightened on to it and firmly held. For holding drills or metal between the sizes above mentioned, there is nothing to supersede this chuck.

Boxwood spring-chucks with metal rings are also

most useful chucks to employ. These are made from thoroughly seasoned boxwood about 3 in. long, divided into sections of different numbers according to the size, and turned taper, so that when the ring is pressed on, the sections all collapse and hold the work tightly in the chuck. A further improvement in this kind of chuck is found in a metal spring-chuck with steel rings. These do not shrink and become untrue like the wooden ones, and are most useful for many purposes, such as holding a number of articles all the same size, or presumably so; which means practically that there is some slight difference. As an example, take a set of draughtsmen. The best way to proceed with such a job is to turn the material, whatever it may be, to a long cylinder, first selecting the spring-chuck that will best suit it for size in diameter; the pieces should then be all parted off with a narrow parting tool, all being made as near as possible the same width. This done, the spring-chuck is placed upon the mandrel-nose, and each piece can then be placed in it as required, and, the ring being gently forced on to the chuck, the work is securely held without further trouble. Before beginning to ornament such a number of pieces as are contained in a full set of draughtsmen, it is a good plan to turn the faces over on each side, and, by setting the depth of cut with the stop-screw on the top slide, this is easily done, rendering them all alike in

thickness. Having decided the depth, the tool need not be moved until all are faced, which saves a deal of time and trouble in measuring, the result being in every way satisfactory.

Cement composed of beeswax and shellac forms a very excellent means of chucking many objects which, from their uneven shape, are difficult to hold in any other way. In some instances the cement is held against the chuck while it revolves, and heat enough obtained by the friction. The material is then simply pressed to it. This, however, is not to be recommended, it being most difficult to centre the work correctly before the cement cools and is too hard.

There are very many objects that, from their limited thickness and uneven edges, are very difficult to chuck or hold, and the best way to overcome this is to apply the cement, but in a different way; also, if three or more parts of any particular object are required to be the same thickness, it is a great assistance. To hold them securely, the following is the proper way: procure a well-seasoned wood chuck, preferably boxwood; face it over perfectly flat and true, then arrange the work upon it so that all the surfaces can be turned over. When so arranged, have the cement melted in a small ladle, and with an iron spoon pour it all round the edges of the work so that it be practically encased about an eighth of an inch deep or more; when cold, the entire number

of pieces may be turned with great ease, and to remove them the chuck only requires a tap with a hammer. And here it may be mentioned, that in doing such work care must be exercised not to let the tool catch, as the jar from such sudden occurrence may possibly displace the work before the desired time.

The component parts of the cement are: three of rosin to one of beeswax, well melted together; other ingredients are at times mixed, but those mentioned are found to be quite sufficient.

Those readers who practise metal-turning will find the same principle exceedingly handy if carried out with solder in place of cement, in which case a metal-face chuck should be kept for the purpose.

The face-plate affords a ready means of holding such work as may require operating upon in various positions eccentric to its axis; the surface of the work being placed upon the face of the chuck and secured tightly to it by bolts and clamps. These are only tightened just to hold the work from slipping round while the chuck is rotated to ascertain the correct position; when this is obtained the bolts are finally fixed.

Many of the objects illustrated in the following chapters have required to be fitted to boxwood plugs, and will be fully described as the subject is detailed. When necessary to resort to this means, the ivory, for

such it will invariably be, must be accurately fitted and fixed with thin but good glue; and when it is to be removed, it is placed in warm water until the glue dissolves, and so releases the ivory. From the natural inclination of the wood to expand under such treatment, considerable care is necessary. The risk is far less when the fitting is slightly taper.

Work of large diameter, or ellipses of extra size, are more easily prepared and shaped under such treatment. As an example, suppose a ring is cut off the end of a tusk of ivory, there would be some difficulty in deciding the best mode to adopt. Such inconvenience may be readily disposed of by surfacing a boxwood chuck, and then, with strong and rather thick glue the ivory is firmly held to it; the glue is required thicker for such a purpose than is necessary for holding ivory work to the wood plugs upon which they are ornamented. One great advantage in adopting this mode of chucking the work is, that the material may remain for a longer period unfinished without altering its position.

CHAPTER III.

ADJUSTMENT OF TOOLS, CHUCKS, ETC.

ALL forms that have been previously brought to the desired shape by hand-turning, or under the influence of the slide-rest, etc., may be so shaped by the various chucks and revolving cutters that they may be decorated in almost endless ways—by perforations, flutes, beads, pearls, reeds, facets, etc.; and the various ornamentations are equi-distantly arranged by the employment of the index-peg and division-plate while the various cutters are presented to the work and driven from overhead. Other means of equalizing the spaces laterally are provided by the main screw and micrometer of the slide-rest, arrested at intervals by the fluting-stops, or, for finer adjustments, by the number of turns or divisions that are made. The partial rotation of the mandrel, under the guidance of the worm-wheel and tangent-screw, also gives results equally necessary to the decoration of compound solid forms. The work is not in any way confined to circular shapes, but by the various instruments may be reduced to

polygonal figures and many other forms. In the case of the original shape being retained, the work is simply held stationary by the index-point while the distinct cuts are made at the required intervals by the different cutters; or, for the alteration of the form, the work may be carried in a rectilinear direction, or partially rotated while the tool revolves. All the various movements in combination result in very curious and beautiful designs, enabling the perforations, etc., to be placed in various groups to suit the design of the object.

CHAPTER IV.

DIVISION-PLATE AND INDEX.

IN the summary of the ornamental turning lathe, reference is made to the compensating index, but further notice of it is necessary in order to give a full explanation of the manner in which it is constructed, and the advantages obtained by its employment.

The index as made in a plain form, without power of adjustment, is simply a straight flat blade in the form of a spring, with a pin at the lower extremity to fit into the ball at the base of the lathe-head, and a point at its upper extremity, which fits into the holes drilled in the division-plate, and by which the mandrel is arrested at the spaces contained in the circle, whichever be used. This form of index, for ordinary purposes, such as dividing polygonal figures, or drilling certain numbers of holes, as obtained from the plate itself, is generally found to be sufficient.

There are various forms or designs of compound and adjustable index-points; the latter, as seen in the illustration (Fig. 1), is that which is generally used,

and, from its powers of elevating and depressing the point which holds the plate, it is a most necessary adjunct and the most appropriate for ornamental turning. The pin which fits into the ball at the bottom of the headstock has a projecting square boss on the end about $\frac{3}{4}$ in. square, through which the lower extremity of the index passes, the latter being screwed with a fine thread, on which two circular metal nuts are fitted, one working between a gap cut in the square, the other acting as a lock-nut to fix it when the necessary adjustment has been made. The nut which is embraced within the slot in the square forms the means of moving the blade in either direction, the result being a partial rotation of the mandrel and pulley, and consequent alteration in the position of the starting-point, or the relative positions of the succeeding cuts to be commenced.

This power of adjustment is of very considerable importance, for although, when the work is in progress, the index remains at the same length, there are many instances in which the like result could not be obtained with an index devoid of the same means of adjustment. It sometimes happens that the first cut may be started without considering whether the number of holes taken for each successive cut will divide equally into the number of holes contained in the circle, and this affords an opportunity to illustrate the advantage of the

starting-point of each circle being drilled on an arc instead of a radial line. If, for example, a pattern has been started at the 192 division, it is possible that, to suit the diameter of work, radius of the cutter, or other of the various points to be considered, the exact distance required cannot be obtained in that particular circle; the index can then be moved to another without the necessity for adjustment in any way; whereas, if the starting-points were drilled on a radial line, the point, moving on a centre and describing an arc, would consequently require adjusting each time a different division was employed upon any similar object.

Another example is found in the fact that it may be required to make perforations or other description of ornamentation at the half of any odd number of divisions that may have been taken—say 3 or 5; this, with the means at hand, is easily effected. The 96 circle divided by 3 will give 32 consecutive cuts; if from any cause it should be desired to cut between the spaces, the division is moved one hole forward, and by aid of the adjustment the mandrel is partially rotated until by trial the exact half or centre of the preceding cut is found to be correct. The movement of the dial-plate is then conducted in precisely the same way as before, by moving three holes each time, and thus in the end 64 cuts have been made.

To facilitate the movement of the pulley and

replacing the index, the circle containing 360 is figured at every 10 with numerals, and has a dot to indicate every fifth hole. The 192 has numerals at every sixth hole, with indicator at every third; 144 in the same way; the 120 has numerals only at every fifth hole, the 112 at every seventh hole, the 84 at every sixth hole, and the 96 at every sixth hole. Thus very many of the divisions are in full view, and go a great way to prevent mistakes. The circle containing 12 holes only is added with a view to saving unnecessary wear to those of larger numbers, and is used for the smaller numbers required for polygonal figures, or when a division of not more than the number contained in the circle is for any special purpose desired.

The use of the division-plate and its accompanying index having thus far been explained as, perhaps, the most important factor in connection with the ornamental turning lathe, the author now takes the opportunity of bringing before his readers an Automatic Counting Apparatus, invented by T. J. Ashton, Esq., which forms a most valuable addition to a lathe. All who have been engaged in ornamental turning have experienced the very considerable attention that must be devoted to this part of the work, and not a few have found that, having nearly finished an elaborate piece of work, the whole has been spoiled by the point of the index being placed in the wrong hole, either through

an interruption, failing light, defective sight, or some other cause; while valuable time and, not unlikely, temper, has also been lost.

The liability to error is general, and acknowledged by most amateurs; and various contrivances for counting automatically have been introduced from time to time, but they have all failed to accomplish the object with the same precision and care as that now to be considered.

In the year 1882 Mr. Ashton so far solved the problem, and, at the conversazione of the Amateur Mechanical Society of that year, he exhibited the Automatic Counting Apparatus (Fig. 2), which the author has since been manufacturing with considerable success, and of which the following is a detailed description:—

A steel sleeve, having a flange in its centre, fits over the end of the mandrel, in the same manner as the ordinary cap used to retain the mandrel between the collars in the headstock; a ring of steel having two arms of different length and definite angles to each other is fitted to the sleeve, and on the side of the flange nearest the lathe-head, where it is retained in position by a nut and washer, at the same time rotating freely on the sleeve.

To the short arm is attached a circular cam, having two projections on its periphery. Through the one the

pin connecting it with the arm passes, the centre corresponding with a continuance of the line of the circum-

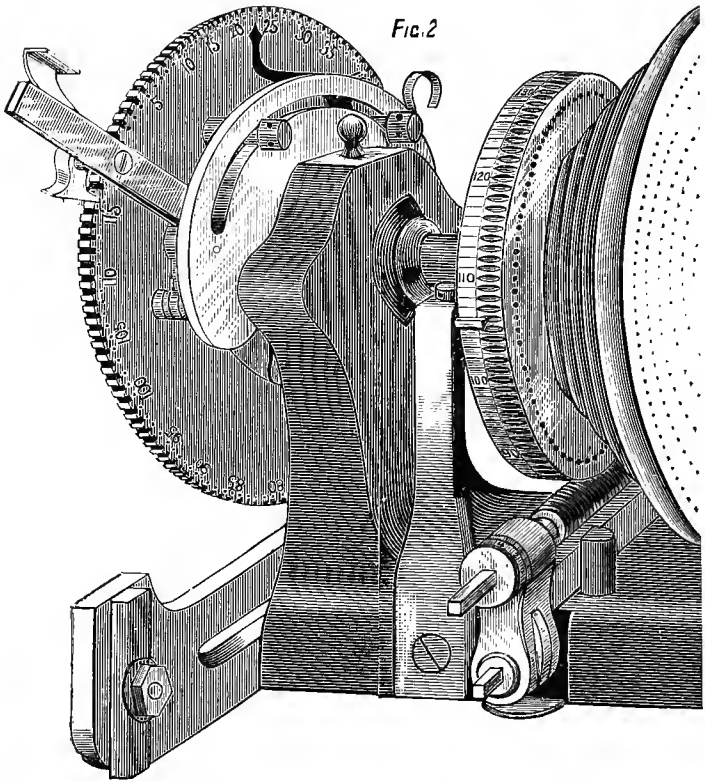

ference. A large aperture is cut in the cam, permitting the sleeve to pass freely through, at the same time allowing a perfectly free action to the cam.

To the long arm is attached a lever, and this, by

means of a strap or link, is connected with the cam ; a spring acts on the lever and retains the cam eccentrically. On the outside or left of the flange on the sleeve, the division wheels, of which there may be several, are fitted ; but one of 192 and one of 120 will give most of the divisions generally used, or likely to be required.

The wheel is securely held to the sleeve against the flange by a steel nut and washer, so that it cannot move except with the rotation of the mandrel. The wheels are 7 in. in diameter, and are slotted, or cut with the necessary number of divisions, all being accurately placed equidistantly round its circumference.

Under each slot or tooth a small hole is drilled, and these are numbered as in the division-plate on the pulley. A steel pointer is arranged to stand perpendicularly, so that the numbers required to be indicated are always in full view. A pawl, as seen by the engraving (Fig. 3), is connected with the long arm, and falls into the slots cut in the edge of the wheel. A longitudinal bar is firmly attached to the bottom of the lathe-head, and carries a strong spring, to which a detent, constructed to fit accurately into the teeth or slots in the wheel, is fixed exactly at the centre of the axis of the mandrel. An arm extends inwards from the spring to about an eighth of an inch beyond an imaginary line, which would be indicated when the

circular cam before mentioned is concentric with the mandrel.

A semi-circular plate, seen in Fig. 2, is fixed to the back face of the mandrel-frame or headstock, having a curved slot cut in it, which carries an adjusting stop with a regulating screw, a second stop being permanently fixed to the plate, the object of the stops being to determine and regulate the movement of the arm to which the pawl is attached.

The action of the apparatus is very simple. Suppose that a wheel of 120 teeth is fixed on to the sleeve, and that it is desired to divide the work into twenty-four equal parts or divisions, the wheel is rotated till the pointer indicates zero, or 120; the detent will then fall into the thirtieth slot, or a fourth of the whole number. The long lever rests on the lower or fixed stop, and the pawl is made to drop freely into the slot by means of the regulating screw. The lever is then raised to suit the number of divisions required, and retained in that position till the movable stop is brought in contact with it; hence, it follows that each time the lever is raised the pawl will fall into every fifth slot, or division, in the wheel.

All being now adjusted, the first cut in the work is made, the arm is then raised by the left hand as indicated by Fig. 3, following the dotted line, and, the lever being pressed on, the circular cam is brought

concentric to the axis of the mandrel, and at the same time impinges against the arm connected with the spring,

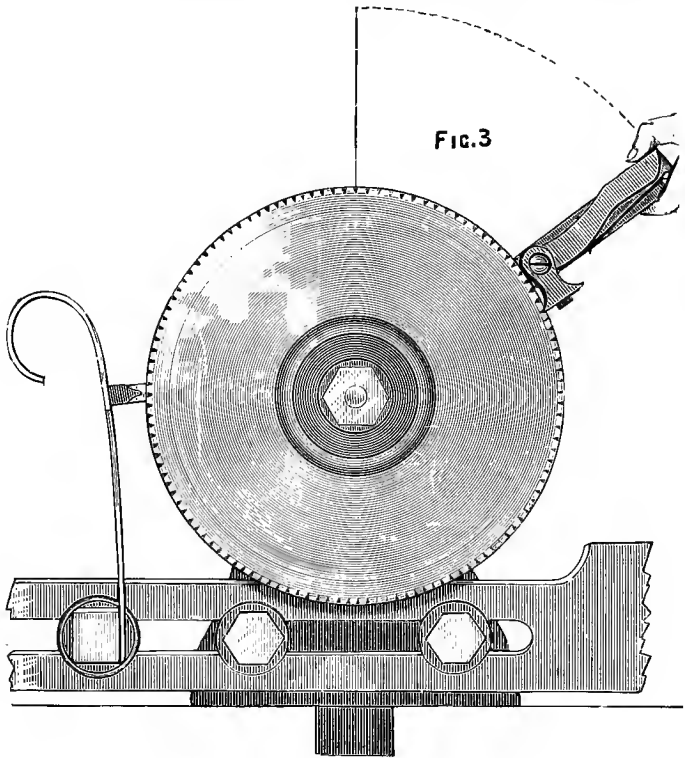

and releases the detent at the back. The arm is then lowered until arrested by the stop, and on the lever being released the detent falls into the thirty-fifth slot, and immovably fixes the mandrel.

One of the most tedious patterns in ornamental turning is that known as basket-work, and is cut with the vertical cutter (Figs. 94 and 95). The variations in patterns obtained by the different movements of the division-plate in combination with it are very great. With the apparatus we are now considering, they are effected with much greater facility, and consequent rapidity. Thus, having cut first at, say, the same division every five, the tool is moved by the main-screw of the slide-rest exactly its own width, denoted by the micrometer; the detent moved, say, one slot or division, and the same number five taken all round again. This will leave the cuts all the same width and length, but one division away from the starting-point. This particular style of work is fully illustrated and explained in a future chapter devoted entirely to it.

Before concluding the remarks with reference to the division-plate and index, the following table of the number of parts into which each circle may be divided will be found of considerable service, as it shows clearly which row may be used for any number of cuts that are required. Various divisions not contained in the table may be obtained by adjusting the micrometer of the adjusting index-peg a certain amount for each consecutive cut, but this will be found a tedious proceeding, and practically it is seldom, if ever, required. The adjusting index, however, for

compensating and obtaining an equal space between any of the different holes, is indispensable.

TABLE OF DIVISIONS OF THE CIRCLES CONTAINED IN
THE FACE OF THE PULLEY.

360 will divide by :

2, 3, 4, 5, 6, 8, 9, 10, 12, 15, 18, 20, 24, 30, 36,
40, 45, 60, 72, 90, 120, 180.

192 will divide by :

2, 3, 4, 6, 8, 9, 12, 16, 24, 32, 48, 64, 96.

144 will divide by :

2, 3, 4, 6, 8, 12, 16, 24, 36, 48, 72.

120 will divide by :

2, 3, 4, 5, 6, 8, 10, 12, 15, 20, 24, 30, 40, 60.

112 will divide by :

2, 4, 7, 8, 14, 16, 28, 56.

96 will divide by :

2, 3, 4, 6, 8, 12, 16, 24, 32, 48.

84 will divide by :

2, 3, 4, 6, 7, 12, 14, 21, 28, 42.

12 will divide by :

2, 3, 4, 6.

CHAPTER V.

THE HEIGHT OF CENTRE OF THE TOOLS.

THIS is a very important point to consider, and although constantly referred to in the details of the various subjects illustrated, a brief summary of the general adjustment will be of service. Although the centering of the tool, when so required, to the precise height of the axis of the mandrel is the most important, there are many styles of decoration that require the tool to be set either above or below the axis of the lathe. The variation, or the result obtained by the three distinct arrangements, is at once seen by Figs. 4, 5, and 6, Plate 1.

To accurately adjust the tool to the axis of the lathe, the elevating ring on the pedestal of the slide-rest (Figs. 13 and 14) is the means to employ, but the testing of the precision is a matter which requires much care, and there are several ways of arriving at a satisfactory result. One of the most general is to turn a flat surface, and by adjusting the slide-rest until the fixed tool will turn off the whole surface without

leaving the least semblance of a point or projection at the centre. In this there is no difficulty, but in many instances the tool is required to be re-centered when it is not possible to use this test.

To overcome this, a metal pillar having a broad base with a projection to fit the interval in the lathe-bed is employed. At the upper extremity a very fine ring is marked round the diameter to exactly correspond with the centre of the lathe; by this it will be possible to adjust the tool to the correct height, irrespective of the relative position of the slide-rest on the lathe-bed.

Another description of centering standard is one that extends on one side of the centre, and in some instances this is of considerable service, as it is not always expedient to move the tool laterally, although from some cause the height may require further adjustment.

A more certain test is to set the slide-rest transversely across the lathe-bed and turn a flat surface, set the revolving cutter or whatever tool may be in use, fix the dial-plate by the index at zero, mark a fine line on one side of the centre, then turn the mandrel round to the half of the division employed, and carry the slide across the surface so that the tool will pass over the same line, which, if the height is absolutely correct, it will do; if not, the correction must be made by the adjustment of the elevating ring.

When elevation or depression of the height of centre is required, it is obtained also by the ring, and when the exact position of it is decided, the ring is fixed by a small metal screw fitted between the lever holes, the object of this being to prevent the ring moving when the slide-rest is moved from surface to cylinder, which from the weight of the slide it is likely to do. When cutting crescents on face-work, the slide-rest may be tilted over in whichever direction the deeper cut is required.

When the fixed tool has been correctly centered, all the revolving instruments should, when replacing it, present the cutters to precisely the same centre; but for many reasons the accuracy should be inspected previously to any cut being made, as the least interference with the under surface of the square stem will materially alter the precision; this may arise from shavings or even dust getting in the tool-box. These, however, are points that must to a certain extent be left to the operator, and may be simply regarded as hints necessary to the exact adjustment of this all-important point.

CHAPTER VI.

GRINDING AND SETTING TOOLS.

GRINDING the necessary tools required for ornamental turning and keeping them in proper cutting condition is one of the most troublesome and difficult operations that the amateur turner has to contend with, and, in his endeavours to help those readers who are not experienced in this branch, the author deems it necessary to set it forth in the following chapter, and as carefully as possible to explain the various instruments, their construction, and the correct way to employ them.

With all tools having straight and angular cutting edges, it is most necessary that they should be retained in the same form and the edges as sharp as possible; to effect this the goneostat (Fig. 4) is absolutely essential. There are various forms of instruments used for the same purpose, but as the one illustrated is the most modern and perfect, no reference need be made to those of a less effective character, and which to a certain extent are now obsolete.

It will be seen by the engraving (Fig. 4) that the

instrument is composed of two plates hinged together by a knuckle-joint and two steel screws, the top of the front plate having a mortise-slot through which the steel arc fixed to the lower one passes, the arc being graduated from 0 to 70° for the purpose of setting the instrument to the necessary vertical angle, when it is fixed by the thumb-screw at the top, under which a steel grip fitting the arc is placed; two steel pillars are fitted in the lower plate, which act as feet, and when in use they rest on a surface while the edge of the tool moves on a stone or plate; at the lower extremity of the front plate a steel tool-box is fitted, the pivot passing through the plate and being held by a screw counter-sunk in the back. A semicircular slot is then cut out in the front of the plate to allow the fixing-screw for the tool-box to pass freely along; the front of the face is then graduated from 0° to 65° each side of the centre.

The two plates being hinged to work at right angles, one to the other, the 0 on the steel arc forms the zero when the plate is precisely vertical, the graduations proceeding from thence round the arc to 70° ; thus, it will be seen that, the two angular adjustments being employed at the same time, the tools are not only ground to the angles required, but can at any time be re-ground or set with exactly the same result. All the tools that have cutting angles are marked at

the lower end of the shaft by figures, which denote their facial angles, while those which differ in shape,

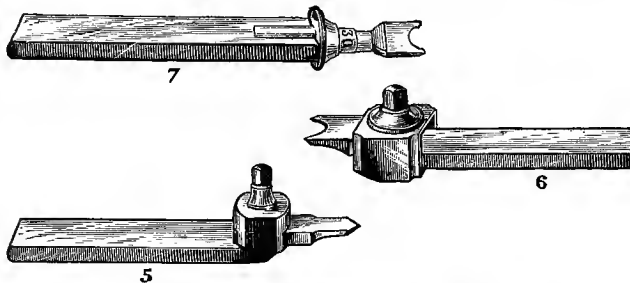

Figs 4

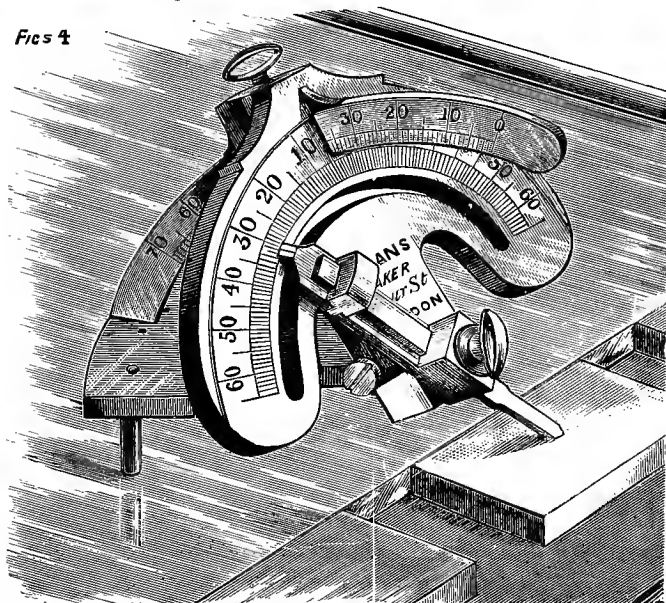

such as the square and bead tools, have figures which represent their width in hundredths.

It is usual to have a box with three drawers, each having a separate slab of oilstone, brass, and cast-iron, upon which the tools are ground; but the author has found it much more convenient to have the three slabs all fitted to the same plate, as seen in the engraving. These are all fitted to be on the same level with a sheet of plate-glass, upon which the feet of the goneostat move; the different slabs can then be used one after the other without the necessity for withdrawing and replacing a drawer each time. The plate-glass is also a vast improvement upon the wood surface as previously used.

When about to employ the instrument to grind up a single- or double-angle tool, it is set to the angle required, both vertically and horizontally. The vertical angle for tools that are to be employed for ivory or hard woods should be 35° . The tool is placed in the tool-box, leaving the cutting edge projecting so that the lower plate, or base of the instrument, will lay parallel to the glass tablet upon which the feet move. As the tools are now usually made of one uniform length in preference to those gradually diminishing with the size of the blade, a line can be marked on each one requiring the use of the goneostat, which will save any further trouble in adjusting the necessary amount of projection in order that the lower plate may assume the required position. When thus arranged;

the tool is rubbed with gentle pressure upon either of the plates, the movement being a series of circles within the capacity of the plate ; the instrument being held in the right hand, the pressure is created towards the point of the tool, but care must be exercised not to tilt the instrument forward. The feet in the base must always remain in contact with the glass plate upon which they work.

The substitution of the plate-glass for the wooden surface has many advantages ; the feet of the instrument do not wear it into an uneven surface, it does not collect the grit, which cut the feet away, and it always remains a true surface-level with the plates. In the case of any considerable fracture occurring to the tool, the oilstone is the first to use, followed by the brass plate charged with oilstone powder and oil. This powder is usually kept in a small tin can ; it is, however, always likely to collect other and coarser grit, and the safest way to procure the powder is to keep a piece of oilstone and chip off a small piece, which can be reduced to the finest cutting powder in a few moments ; it is then sure to be free from any other substance. The tool having been ground up so far on the brass plate to the angles required, the vertical angle should be diminished by 3° and the tool carefully applied to the brass plate ; this produces a second facet of less acuteness, which enables the tool to

longer retain the excellence of its cutting edge. Having ground both angles thus, the oilstone powder is removed from it, and the second or obtuse facet finished upon the cast-iron plate charged with very fine crocus powder and oil, and with this it is not only

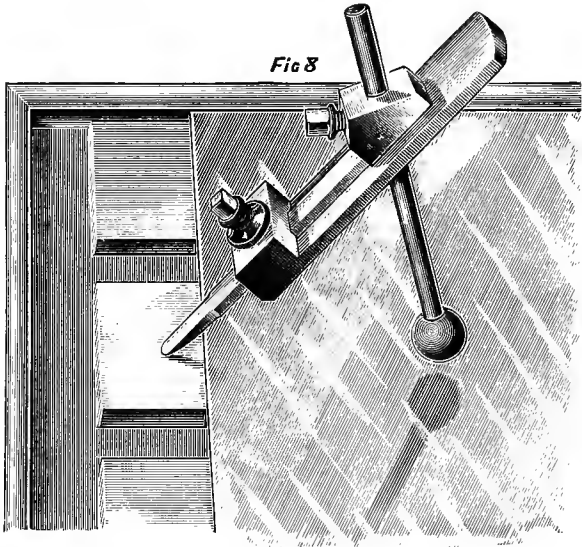

finished grinding, but, the crocus having little or no cutting power, it is brilliantly polished, which adds greatly to the beauty of the work cut with it. When the facets have been thus finished, there will possibly be a very slight burr on the face, the extent of which, however, will depend much upon the hardness of the

tool; this is removed by placing the face of the tool on the iron plate and gently rubbing until it is removed. It may be possible that recourse to the brass plate will be necessary; in any case the burr only must be removed without altering the face of the tool, as that denotes the exact height of centre.

The eccentric cutters having angular-cutting edges are operated upon in precisely the same way, and are held in the small socket (Fig. 5); the vertical cutters assuming the same position in the socket (Fig. 6). The socket (Fig. 7) is applied in the same way to hold the drills, the astragal and angular facets of which are treated in a like manner.

The sharpening of curved edges, both concave and convex, has been the subject of considerable thought for some time. The instrument (Fig. 8) designed by the author overcomes the difficulty with regard to the round nose or convex edges. It will be seen that it is made to carry the tools and different sockets in the same way as the goneostat, and has a steel rod passing through the centre at an angle. On the end of the rod a small ball is fitted, and, the instrument being moved round on this as a centre, causes the tool to follow its curve on the oilstone or brass plate with the cutting powder upon it. The vertical angle or cutting bevel is altered by moving the ball nearer to or farther from the centre. It has been found to fully perform

all the necessary actions required of it, and is largely used by the leading amateurs.

We next come to the sharpening of bead and moulding drills. For this purpose a series of cones are required, and these are made to revolve in a small lathe-head fixed in the hand-rest and driven from the overhead motion, or by a pulley on the nose of the mandrel, with a short band from thence to the instrument. The cones are revolved at high speed, charged with the different powders, the same that are used on the flat plates. When thus revolving, the bead is passed up the cone until it fits the diameter, when it is held there, the cutting substance being held to it on the finger.

For the various moulding tools and drills, a series of slips of Arkansas stone and brass of various sizes are necessary, the latter being charged with the cutting powders as before mentioned. The shape of the moulding tool will admit of the different slips of numerous shapes being applied, when they are gently rubbed over the forms at the precise angle or bevel at which they are made; this is an important feature in such tools, as a rounded edge is not capable of cutting cleanly.

The various fillets and curves are thus sharpened independently of each other, and the goneostat always employed for the transverse astragal or terminal edge.

There are various kinds of grinding machines fitted to mahogany frames, similar to a lathe; first, the vertical grinding machine having five different spindles, each of which requires to be changed when another is used. The spindles are fitted with two stones, one brush, one buff, and one metallic lap; it has a drop-can and water-trough also fitted over the stone.

The horizontal grinding machine is fitted to a double frame, and carries separate plates of iron, brass, and lead. This is used for setting tools in the goneostat, and for grinding a variety of other tools; it is also used for cutting and faceting stones and other substances.

Fig. 9 illustrates a newly designed combination grinding machine by the author, which embodies all the necessary appliances on one stand. By reference to the engraving it will be observed that the machine consists of a short double frame of mahogany, with fly-wheel, crank, and treadle. One side of the frame is carried upwards, and receives the centre-screw; at the opposite side an iron standard is fixed, through which the end of the spindle passes, forming a mandrel; on the spindle are fitted a stone, buff, and metallic lap, a driving pulley being also attached to it over the fly-wheel.

In the front of the mandrel are fitted the various cones for sharpening the bead-drills, and this forms a

great feature in the machine; it does away with the necessity for the small lathe and cones previously alluded to; and, not only is this a consideration, but it

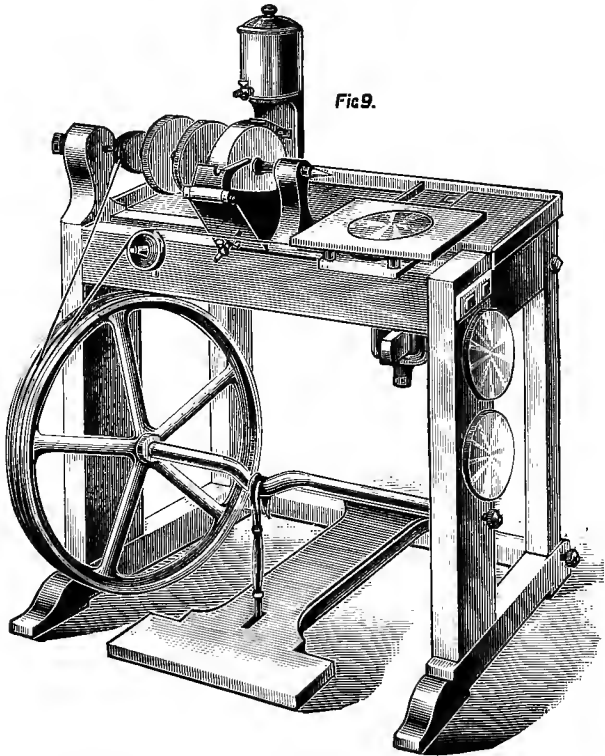

is sometimes important that a drill should be sharpened when the work is in hand, in which case the small lathe cannot be used unless a second complete lathe

is in readiness, whereas, with the machine under notice, it is always accessible. The mandrel may also carry drills and the various polishing buffs, etc.; in fact, it forms really the second lathe, the want of which is so often felt.

To the right of the mandrel a horizontal grinding-machine is fitted, the frame passing through the bed. In this a steel collar is fitted, and a steel mandrel similar to a traversing one, the object of this being to raise and depress the height of the plates by the centre-screw at the lower extremity; the nose of the mandrel is screwed to receive the plates, which are fitted in the same way as ordinary chucks. On the top of the frame a cast-iron table is fitted, and can be removed at will. The centre of this is turned out to fit over the periphery of the plates or chucks. A pair of guide-pulleys, fitted one to each side of the frame, conducts the band from the fly-wheel to the pulley on the mandrel, which revolves between the frame and the table. By the centre-screw the plates are adjusted to a level with the table, and, when using the goneostat, this is of considerable importance. At the back, on the top-board, is fitted a piece of mahogany having the oilstone, brass, and iron plates, also the sheet of plate-glass upon which the feet of the goneostat move; this is exactly like that seen in Fig. 4, upon which the instrument stands. The different plates are screwed

on plugs to the side of the frame for convenience, and a cover fits over the flat slabs to keep them free from dirt, etc. In the water-trough a small tap is fitted to draw off the water, as in no case should the stone be allowed to remain immersed, or it will become soft at that part, and useless.

This machine has quite taken the place of those made separately, and is admitted to be the most useful of its kind that has yet been introduced. The author feels great pleasure in stating that the dispensing with the separate spindles and the introduction of the plate-glass table were instituted at the suggestion of Arthur Warre, Esq., who from experience proved them to be the best form.

CHAPTER VII.

MATERIALS APPROPRIATE FOR ORNAMENTAL TURNING.

OF hard wood there are many varieties, but few that are really good for ornamental turning; African black being the finest to be procured for specimens to be highly decorated. This wood is obtained in logs of various sizes, but the result of cutting up one of large dimensions is often very unsatisfactory; the larger logs, or what should be termed the trunk of such a tree, is always faulty in the centre, and perhaps from a diameter of 15 in. to 24 in. nothing sound exceeding 3 in. to 4 in. will be obtained. Even when a satisfactory-looking piece is further operated upon, fresh blemish or worm-holes may appear; yet, although the waste incurred in cutting up any quantity is at times serious, the excellent quality of that which is really sound amply repays for the time and loss.

African black may certainly be said to rank next to ivory in every respect; sometimes it is marked with a few varying colours, but these die out in time, and the whole is quite black. One of the real difficulties

with regard to it is the limited size in diameter to be obtained. If it is cut from a large log, plankways, the necessary diameter can be procured, but although it is the only one of the hard woods that can be used in this form with anything like satisfactory result, it is better avoided if possible.

Cut up in the usual manner and turned the endway of the grain, it is as close and uniform almost as ivory itself, and for face patterns is quite equal to it, while in some kinds of work the pattern is even more effective. It acquires a beautiful polish, which can only be achieved in such material with a keen cutting tool.

Cocus is the next in quality suitable for ornamental turning, and, when exceptionally good, is almost as close in texture as the black wood. It varies considerably in colour; the lighter shades, however, get gradually darker by exposure. This wood, again, is not, as a rule, to be obtained in very large diameters, although at times it is possible to procure a piece from 7 in. to 8 in., but with a faulty centre; this can be plugged or covered with some other material as a centre.

For those subjects which are left in the form resulting from plain hand-turning, king, zebra, coromandel, and cam woods answer fairly well. Boxwood forms, perhaps, one of the most useful adjuncts to the amateur workshop: it is abundantly used for chucks; it affords

a means of practising economy and saving time by making trials, both of form and decoration, previous to operating upon the more valuable materials, and should be regarded as indispensable to the practice of the art.

It is not the intention of the author to give a long detailed account of all the different woods to be turned, but only to say a few words upon those that he considers applicable for service in ornamental turning.

Ivory is, without exception, the finest material for the various purposes connected with the art we are now considering.

There are two descriptions that are generally used for turning purposes, the Indian and African ivory. The former is close and regular in texture, and somewhat white in colour, especially when first turned, but, if exposed to the air, it loses a deal of its freshness, and ultimately becomes yellow. It will take, however, some length of time to make a material change, and, if kept under glass and air-tight, little difference will be detected for years.

The African ivory is considered, and is, from its general tendency to retain its colour, more suitable for many subjects, and that which is termed green or transparent ivory, from its containing more natural moisture or sap, gradually dries to a very beautiful pearly white, which is very much more appreciated than the dead opaque white of the Indian ivory.

In preparing the green ivory, its natural state has to be considered, inasmuch as it should not be worked up immediately after it is cut from the tusk, as the contraction or expansion inherent with all materials used in a similar state will tend to destroy the fittings or joints, either screwed or plain. Such ivory should be cut into suitable blocks, then carefully turned up, glued or gummed over at the ends, and left for a long time—some months, if possible ; in fact, the longer the better.

This short outline of the qualities of the two distinct classes of ivory will be sufficient to show that, in selecting such material for any specimen of ornamental turning, it is necessary it should be all of the same kind, either one or the other. Many handsome articles have been spoiled by a mixture of the two, one part being opaque, while the other is of pearly whiteness, the contrast being detrimental to its elegance.

There are, however, two drawbacks to the use of ivory ; first, the difficulty of obtaining it of large dimensions, and secondly, the somewhat extravagant price which has to be paid for it. The largest size is naturally always at the hollow end, and in most cases this has a large aperture. When of this character, it is used for such objects as miniature frames, bases for pedestals, etc. The solid ivory does not commence till some distance up the tusk, where it becomes gradually smaller. The nerve, however, runs entirely through

the whole length of the tusk; therefore wherever it is cut this will be seen, and sometimes it will be found wide of the centre, necessitating a recess of large diameter being turned out in order that it may be hidden by a solid piece, which should be as near the same texture as possible.

In building up subjects requiring many pieces of different diameters, it is almost impossible, without considerable waste, to cut it all from the same tusk, but this is not so important if the pieces are carefully selected. Small pillars or handles should be cut from corresponding tusks, commonly termed "scrivelloes;" but at times the diminished size required will not admit of this without great loss; therefore such pieces may be cut from the sides of a large hollow. Ivory is at times cut plankways, but when so used requires considerable care in the penetration of the tool and its excellence of cutting edge, in consequence of the different direction the grain takes.

CHAPTER VIII.

POLISHING OF IVORY AND WOOD.

ALL work in ivory that has been decorated with the various instruments, revolving cutters, etc., should not require any other polishing than that which is left from the tool, and the excellence of this is entirely dependent upon the condition the tool is brought to before being used. For work of shallow depth, the tool, when properly sharpened, will last to the completion of the pattern, but, for very deeply cut work, the tool will require to be sharpened perhaps more than once, and should always be reset for the final cut. There are no means to be employed to polish work of this kind except a soft brush, with whiting and water about the consistency of thick paste, with which it is well brushed and then washed with yellow soap and water, rinsed in clean cold water, and then dried in boxwood sawdust, the latter soaking all the water out of the excavations ; when dry, a soft and perfectly clean brush should be used to remove any remaining portion of sawdust and to finally polish it. It will then be as bright

and clean as possible, provided it has been cleanly cut and the facets left bright from the tool; if roughly cut, all the brushing it may receive will not improve it.

All plain forms in ivory, portions of which are not to be in any way ornamented, should always be polished before any cutting is commenced, and it has been found advisable to polish carefully even that portion which is to be cut, as it may transpire that from some cause, or alteration of idea, the pattern to be placed on a certain part will be considerably improved by not being cut up sharp; and, if this should be the case, the beauty of the facets left between the successive cuts will be greatly marred by being left unpolished. To polish the plain form, it should be got up perfectly free from marks, scratches, etc., then whiting and water applied with a soft rag, and well rubbed while the work revolves at speed. A still better result may be obtained when the work is so far polished by placing a soft circular lambswool pad in a chuck on the mandrel of the grinding machine (Fig. 9), and, while revolved at a quick speed, the work held against it; hand-buffs of the same material are also very useful for similar purposes. Oil of any kind whatever should be carefully kept from the surfaces.

Some description of ornamental patterns will bear finally polishing in the same way without in the least destroying the beauty of the sharp edges. All reeded

columns, the edges of which are not required sharp, are also polished in the same manner.

To create a better effect on black-wood subjects, a short soft brush with a very little beeswax may be employed, but this is hardly to be recommended, as the work, especially face patterns, should be left bright from the tool, and not require further treatment.

The question has been asked more than once as to whether the colourless hardwood lacquer, or varnish, will not aid the amateur in finishing the work; the object, however, will never look well after it has been applied, no matter how carefully it is done, and it is strongly advised that all work should be left entirely free from any such treatment.

CHAPTER IX.

OVERHEAD MOTION.

IN Fig. 10 is illustrated an overhead motion, which is so far superseded by the one previously alluded to, and fully described in the following chapter, that its demerits will be at once obvious. The spindle carries a pulley for the long band from the fly-wheel, and a sliding drum (sufficiently long to suit the length of the slide-rest), which may be fixed at any position along it. The frame in which the spindle runs between centres is supported by two regulating screws, which pass through nuts with curved ends that move in a corresponding curve at each end of a strong steel spring. This is held at its centre by a screw and bow-handle beneath the bent arm of a single standard, the latter carried to the foot of the standard of the lathe, where it fits into a metal washer, placed in the frame to receive it; it is more convenient if the standard is put together in two pieces. The regulating screws and milled-heads are used for adjusting the tensions of the band.

The band passes from the fly-wheel to the pulley on

the spindle, and a second band from the drum to the pulley of the revolving cutters, and this is a point of failure in this particular style of overhead. A separate

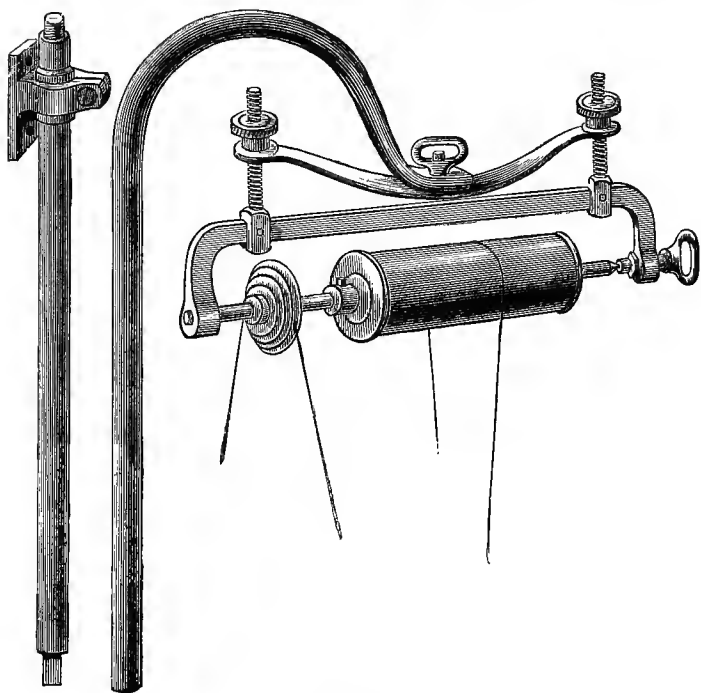

Fig. 10.

band is required for every instrument having a pulley of increased size, or, in the instance of the universal cutter, where the band has to pass over guide-pulleys; the alteration of the tension is troublesome, the vibration

excessive for want of support, and, although a useful apparatus, it is now superseded by that illustrated by Fig. 11.

This consists of two standards firmly bolted to the lathe-frame, and connected at the top by a triangular

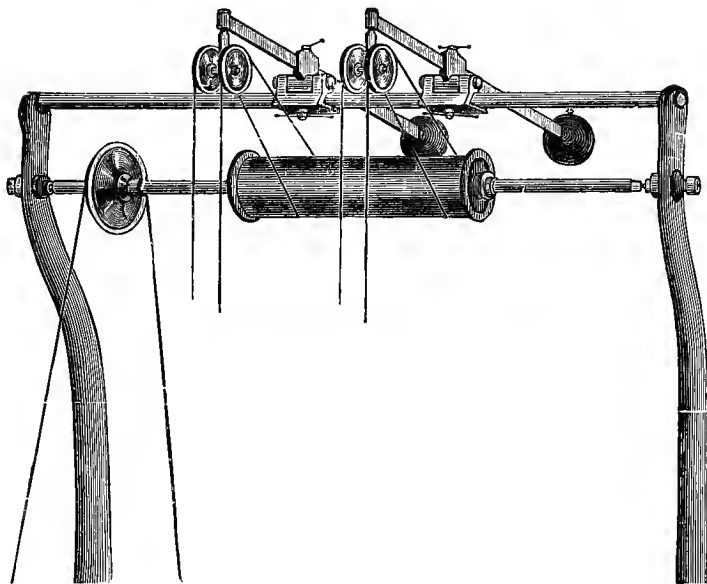

Fig. 11.

bar secured by a nut at each end; beneath this is a steel spindle running on hardened centres and carrying a pulley and drum. On the triangular bar is a frame that can be moved laterally; this carries a second frame working on centres, through which also a tension-bar

slides; at one end of the latter two guide-pulleys are fixed, and at the other end a counterbalance weight.

A band passes from the driving-wheel to the pulley on the spindle, which has various-sized grooves for alteration of speed, and gives motion to the spindle and drum. A second band passes from the drum over the guide-pulleys on the tension-bar, and thence to the pulley of the cutter-frame carrying the cutter.

This second band need never be removed, and it is obvious that in applying it all that is required is to pull it down till it passes over the pulley of the instrument in the tool-box of the slide-rest. As previously stated, it has been urged against this form of overhead that, in consequence of the pulleys above being attached to the tension-bar, there is an undue amount of friction; but this exists solely in theory, and the statement is quite erroneous; also, that the guide-pulleys being overhead, the oil is likely to be dispersed over the operator; this is also entirely a delusion. If properly oiled, there is not the least fear of such a result. Since the engraving was completed, the author has decided that a second pulley (as seen in Fig. 1) is preferable in place of the drum; also a third pulley when the overhead is fitted with a second carriage and tension-bar, which is necessary for the complete working of the automatic slide-rest (Fig. 17).

The advantages possessed in this form of overhead

motion are: its rigidity, its freedom from vibration, the ability to make use of it at any point throughout the length of the bed, the ease with which the tension is adjusted, which is done by simply moving the counter-balance weight to or from the centre, and, above all, the fact that no second band is required for the various instruments, the same that will drive the eccentric cutter or drill-spindle being equally effective with the epicycloidal, or rose-cutters. The fact that many scientific amateurs now use it is sufficient to certify its superiority.

CHAPTER X.

THE ORNAMENTAL TURNING SLIDE-REST.

THE general accuracy of the work produced by the aid of this tool, together with the comparative ease with which it is employed for plain as well as for ornamental turning, renders it an indispensable addition to the lathe ; and to those of only small experience it will be anything but a difficult tool to manipulate.

To show more clearly the advance that has been made in the general construction of the slide-rest, one of incomplete design, although not to be considered the primary instrument, is illustrated by Fig. 12. The tee-slide, which is 12 in. long, is fitted to a pedestal of cast iron ; this is securely fixed to the bed in the requisite position by a dove-tailed slide, with a bow handle and washer at the lower extremity. The tee-slide is of proportionate width on the surface, and planed to an angle on each side. To this a metal plate is fitted, having on one side a bevel cast in the solid, while that on the opposite side is formed by a loose strip of the same angle, attached to the plate by two screws ; two

set-screws in the side of the plate, with their heads extending partly over the edge of the strip, are employed to set up the slide during its process of manufacture, and to be used for the same purpose in case of ultimate wear.

Two double-chamfered steel bars are now fixed across the plate at right angles to the tee-slide, and

Fig. 12.

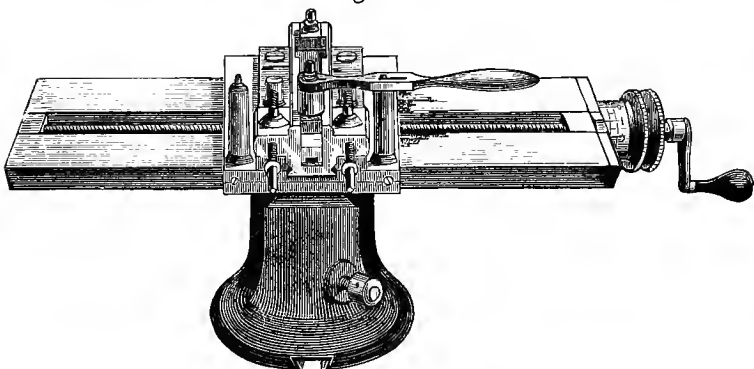

secured by two screws in each, the holes on one side being elongated so that set-screws in the side of the bar set the slide up to its bearing. The metal tool-box is planed all over, the receptacle being made the standard size to receive the stems of the different instruments, which are $\frac{9}{16}$ in. square.

On the sides of the tool-box two projections are cast, and through each is fitted a screw of ten threads to the

inch. These are termed the "guide" and "stop-screw;" both are squared at the ends to receive a key or winch-handle. At each side of the lower plate a steel pillar is fixed, the top of which receives the body of the lever, the latter moving in a radial slot, the front of it being fitted to one of the clamps that hold the tools securely in the receptacle; the end of the lever terminating in a curve to suit the hand.

The tee-slide is accurately drilled at each end, and countersunk on the right side to receive the collar of the main screw, which is also ten threads to the inch; a metal plate is then attached to the end of the slide to retain the screw in its place. A metal micrometer is fitted on the projecting end, divided into ten equal parts, and these are read from a line across the top of the end-plate.

When using a slide-rest of this limited construction, it is necessary to employ a set-square and set-bevel in its adjustment, and by these it is set parallel with, and at right angles to, the lathe-bed, the former position being required to turn a cylinder, while in the latter it is used to operate upon the surface. In order to facilitate the use of these instruments, it is necessary to turn a perfect cylinder and a true flat surface, and when setting the rest to either position the set-square is placed in the tool-box, and held with the blade in contact with the test while it is bolted to the lathe-bed.

This plan is not to be recommended for many reasons, as it is likely to shift during the process of binding it to the bed. The set-bevel is used for setting the slide to angles, and is applied in the same way.

Fig. 13, although of a similar character, and to be used for the same class of work, is of a more complete construction. The tee-slide in this case is 14 in. long,

FIG. 13

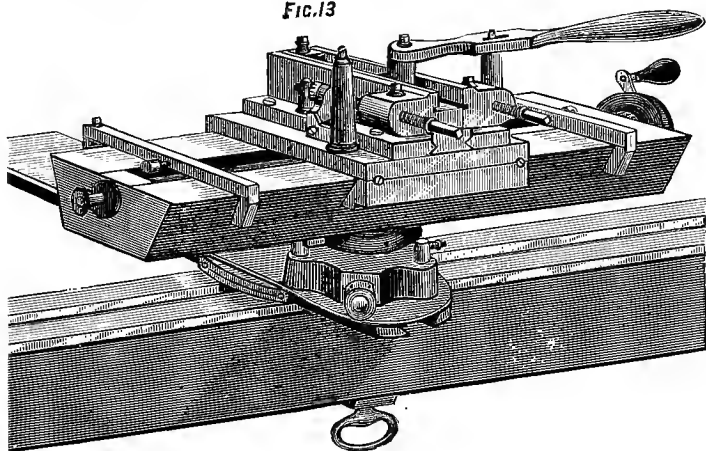

but in other respects the metal slides are similar; the guide-screw on the left side of the tool-box has fitted to its end a steel collar divided into ten equal parts, and figured 0, 2, 4, 6, 8; in front of this a steel bridle is fitted, and fixed to the steel side-bar, so that the collar rotates between it and the pillar against which the point of the screw bears. By this addition the top

slide is placed under complete control independently of the lever, leaving one hand always at liberty and free for other purposes. This is obviously a very great advantage, and, although some turners, from long custom, are still in favour of the lever, there can be no doubt that the ability to dispense with it is of considerable importance. The steel bridle is made open at the end, so that it passes over the screw, and, in removing it, all that is required is to take out the screw that binds it to the steel bar. A screw with a flat end passes through the pillar opposite the centre of the guide-screw, for the purpose of taking up any wear that may occur between the two faces of the collar, and so prevent any movement of the screw without a corresponding traverse of the slide, which, in other words, would be backlash or loss of time. It has been found a great advantage to have all micrometers as large as possible, as the readings are more accurate.

To the tee-slide are fitted, to operate one on each side of the traversing slide, a pair of fluting stops, one angle being in the solid and one loose, the latter attached by a steady pin and screw, and, by tightening it, the stop is securely fixed to the slide. These are used to determine the lateral traverse of the slide in either direction, and are indispensable for work requiring a series of flutes or excavations of corresponding length; they are provided with adjusting screws

through the centre, by which a finer degree of movement is obtained.

The pedestal of the slide-rest (Fig. 13) is planed square on each side throughout its entire length to a depth of $\frac{5}{8}$ in., and fitted to a metal cradle; this addition is of the utmost importance, as will be seen. The cradle has a substantial tenon on the under side, planed to fit the interval of the lathe-bed; two adjusting screws are then fitted to set it accurately in case of wear. It is then carefully planed on the upper side at right angles to fit the pedestal of the rest, one side having a loose strip with set-screws for final adjustment. The clamping or holding-down bolt passes through the tenon.

By this arrangement the pedestal can be moved at right angles to the lathe-bed, and refixed without fear of inaccuracy. On the top of the pedestal two steel pillars are fixed, and have through each an adjusting top-screw, which has contact with a steel pillar fixed to the under side of the tee-slide; and by this means the main slide is set to operate on the surface or cylinder, and may be moved and reset with the greatest ease, without reference to set-squares of any kind. A metal ring is also fitted to the pedestal, for the purpose of elevating and depressing the point of the tool to the correct height of centre, also placing the same above or below the axis of the mandrel.

By this improvement it will be seen that the set-square and set-bevel required to operate with Fig. 12 are practically superseded, and for such purposes may now be regarded as obsolete. The end of the main screw of Fig. 13 is carried through on the left side, and provided with a socket, to which the wheels of the spiral apparatus can be attached.

Fig. 14 illustrates a slide-rest of the latest design and most complete construction, being provided with every action that can be required. In many respects it is similar to Fig. 13, but the various extra movements attached to it are one and all of great service, and it may be regarded as a most perfect tool.

The pedestal is made 4 in. longer than Fig. 13, to admit of extended movement from the axis of the lathe transversely. The metal cradle is in every way a facsimile of Fig. 13, and the tee-slide is 18 in. long and proportionally substantial. The slide-rest last described is provided with the means of setting it accurately, either parallel or at right angles to the lathe-bed, and consequently any angle between these two points can be obtained and the slide fixed by the binding-screw; but it will be noticed that in Fig. 13 there is no means provided of ascertaining the precise angle the slide may assume, while in Fig. 14 it is decided in the following way:—

A metal arc is attached to the pedestal below the

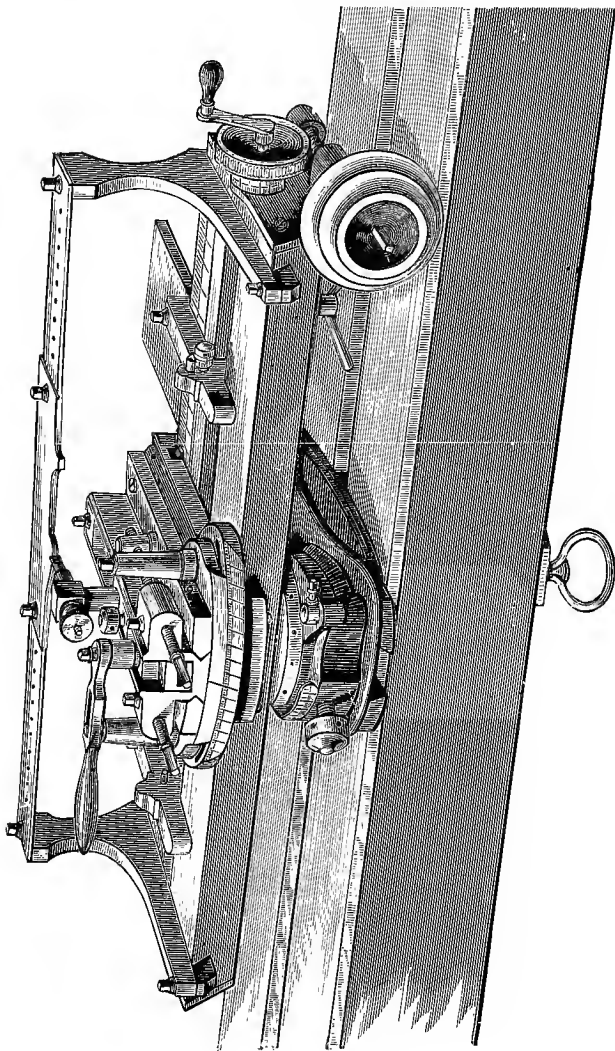

Fig. 14.

elevating ring, concentric to the cylinder fitting of the stem of the slide; it is fixed between the pillars that denote the two positions of the rest, and held by a screw passing through the base, the hole being elongated for the convenience of accurate adjustment; the vertical face of the arc is divided from 0° to 90° , and a steel-pointed index fixed in the under side of the slide

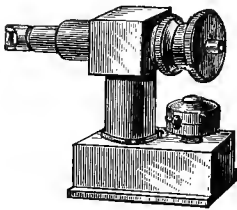

Fig. 15.

indicates the precise angle at which it is set. Therefore, when the rest is set to turn a cylinder, the index will read at 0° , and when turned to the surface it will point at 90° .

This, however, is provided for by the stop-screw, and the

object of the divided arc is to ascertain and repeat any angle that may be required between the parallel and right angle. An angle of 45° is very often necessary, and is employed when cutting hemispheres with the eccentric cutter, and also for a variety of other purposes.

On the tee or main slide of this rest a metal plate is fitted in some respects similar to that in Fig. 13, but extended on the front side with an arc at the front. This forms the base of the traversing slide, and to this a second plate is fitted to move upon a centre in the opposite side; in the arc a semi-circular slot is

cut out, through which a screw passes into the top slide to fix it to the lower plate. On the top of the second plate the tool-box is fitted to the steel double-chamfered bars in the like manner to Fig. 13, the clamps, etc., being fitted in the same way. The projection through which the depth and stop-screw pass have metal plugs let in, and the screws pass through a portion of them, so that, when the screws at the top are tightened, the main screws are fixed, or, when released, they are free.

The advantages of the slide which carries the tool-box turning on a centre, and thus presenting the tool at different angles to the work, are obviously very great indeed. Undercutting or dovetailed grooves may be produced, the shapes of the mouldings may be varied, pearls may be cut in relief, and in many instances the tool may be placed in contact with the work in such a way as without it would not be possible. The fluting stops, it will be seen, are fitted in a different way. In consequence of the arc projecting over the surface of the main slide, they cannot be fitted entirely across the bed of the slide, as in that previously alluded to; they are therefore shortened on the front side, and their holding power vested in one side of the interval in the slide and the opposite angle. They are fitted with improved spring readers to the adjusting screws, which cause the lines—that is, those on the screw-head and

that on the indicator—to be always in close proximity, thus rendering a degree of accuracy not to be obtained by the screw simply passing through the centre. The stops fitted in this way are found to effect every purpose. The left side of the screw is also provided with a socket to carry the spiral wheels.

On the right side of the slide is fitted an arrangement with worm-wheel and tangent screw, the micrometer on the screw being cut on its periphery to 75 teeth, a metal frame working underneath with a steel tangent-screw. This is thrown in and out of gear instantly by an ingenious lever action, which was suggested by T. J. Ashton, Esq., and carried out by the author. For grailing or self-acting cuts it is a valuable addition, and can be applied to either the cylinder or surface. Grailing may be effected by the movement of the micrometer to a certain division, denoted by the reading line on the plate, and a double-angle tool inserted to a very slight depth at each movement; but this is a tedious and long job, requiring the greatest care. The effect of grailing work is so advantageous to all patterns cut upon the surface that it cannot be too strongly recommended, and it is produced with this action so much more quickly and correctly that the apparatus is justly considered a great acquisition. The result is actually a very fine screw, but this in no way deters or mars the beauty of the work. The lines may

be made finer or coarser by altering the relative speeds at which the screw and the work rotate, but the lines, or rather the line (it being one continuous scroll), gives absolutely equidistant spaces. It is upon this that the beauty of such work depends, and when it is done in consecutive cuts by the movement of the main screw for each individual cut, it is, as before stated, a tedious, long, and somewhat uncertain matter. The cutting edge of the tool should receive special attention, as much depends upon it. With the self-acting motion, the tool cannot remain an undue length of time in any one part, which, in taking the consecutive cuts, it is likely to do, the result of which has a tendency to destroy the edge of the tool and create a slight difference in the appearance of the cut.

In the preparation of long cylinders or broad surfaces it has a great advantage, as, the tool being once set to the depth, it passes entirely over the work without further attention. For fluting also it is a most useful addition, and the divided scale on the surface of the main slide is a great assistance for this purpose. The exact contact of the slide with the fluting stop is not so accurately decided, but the index which points to the line on the slide will enable the lever to be moved out of gear at precisely the same division for each successive cut, and by reference to Fig. 16, which is an enlarged engraving of the action, it will be more

readily understood. The worm-wheel is attached to the screw of the slide-rest ; the end-plate which retains it in its place is extended at the under side, so that the frame which carries the tangent-screw can be pivoted through at one side ; a right-angle lever is then fixed to the bottom of the main slide ; the short arm which

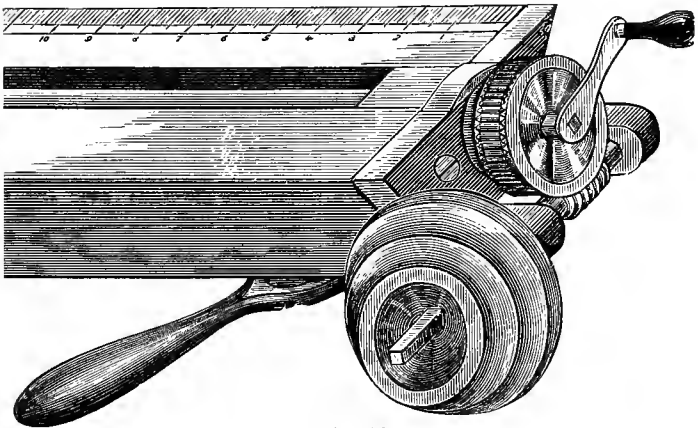

Fig. 16.

lies under the slide passes through a long mortise-slot in the plate, the end of which is turned to a short cylinder, and works in a curved slot sunk in the frame that holds the screw, and, by moving the lever to the right or left, the screw is thrown in and out of gear instantly. The band may be crossed for the return cut, or the tool moved back to the starting-point by the winch-handle, which is in some respects preferable.

The scale on the main slide is divided in tenths, or at every turn of the screw, and figured at every inch.

The action of the tangent-screw gives such a regular traverse to the slide that it is vastly superior in this respect to that obtained by the winch-handle, although the latter is at times more appropriate. The slide-rest (Fig. 14), it will be seen, is fitted with the curvilinear apparatus attached to the slide in an improved fashion introduced by the author. This is fully explained in a future chapter devoted to the apparatus and its results.

CHAPTER XI.

AUTOMATIC STOPS.

A FURTHER development of the compound slide-rest and automatic stop is found in the illustrations (Figs. 17 and 17A). The rest is provided with a second, or rather third, slide, and, as it slides also in a metal cradle, it is available as a fourth. The cradle is planed to fit the interval between the lathe-bed, and, again, at right angles to it; the lower slide is then planed to fit it, having a single bevel of about 30° on one side, the opposite being square, a set-screw passing through the side of the cradle to keep it always so. The under side has a dovetail groove planed in it for the holding-down bolt. On this slide a substantial plate is fitted, with one angle cast in the solid and one loose strip adjusted by set-screws. This slide is actuated by a screw of ten threads to the inch, with a micrometer attached to it. In the centre of the plate a large metal socket is fitted, held by a steel washer of corresponding size on the under side, and this is fixed by a semi-circular clip and screw, which passes through a short

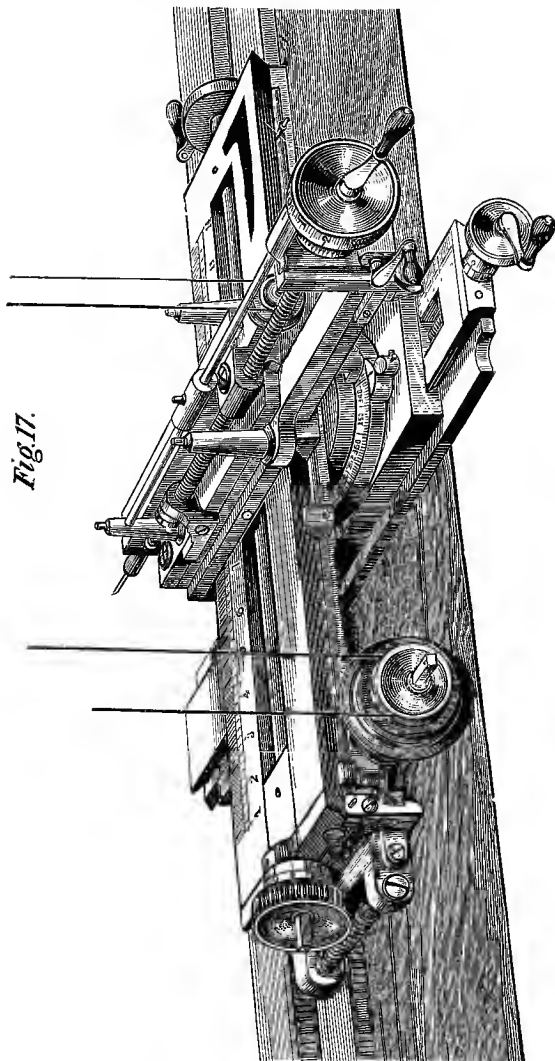

steel post in front of it. The centre of the metal socket is then bored out to fit the stem of the main slide, and on the base of the socket the pillars and stop-screws, for setting the slide to surface or cylinder, are arranged; on the space between the same is a divided scale in degrees from 0 to 90, thus forming the means of obtaining the necessary angles between the

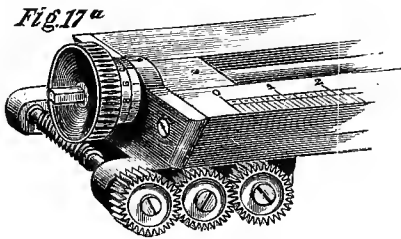

two specified points, the slide being fixed by a screw passing through the lower rim of the socket.

The main slide and tool-box are both fitted with automatic actions, also the invention of T. J. Ashton, Esq., and form a most important improvement. The main slide is provided with fluting steps, which work automatically, and are fitted in the following manner: A metal frame carrying the tangent-screw is hinged on a spindle; to one end of it is attached a driving-pulley having various speeds, and to the other end a toothed wheel gearing into an intermediate one, from thence to a third wheel, the latter being fixed to the

end of the shaft of the tangent-screw, the whole being fitted up on a metal block, which is attached to the bottom of the tee-slide, so that the tangent-screw will, by its own weight, fall out of gear with the worm-wheel. The mode of gearing is clearly shown by Fig. 17A.

The frame is retained in position by a catch, connected with a double lever, and runs the whole length of the main slide, being connected with the lever at one end. On the rod at each side of the traversing slide, which carries the tool-box, is fitted an adjustable stop which can be fixed at any required point by a set-screw.

The action may be thus briefly described: A band from the overhead motion passes to the pulley, and by means of the wheel-gear (Fig. 17A) communicates the motion to the tangent-screw, and through the worm-wheel to the main screw, thus giving traverse to the tool-box.

The stops, having been fixed on the rod at the required length of the flute, will, when pressed on by the advancing slide, so act on the lever of the catch that the tangent-screw immediately drops out of gear, and although the lathe is not stopped, the tool is at perfect rest. To make the next cut, the band may be crossed on the pulley, when a reverse traverse is the result; but as it is necessary that all finishing cuts

should be made in the same direction, it is better to run the slide back by the winch-handle to the starting-point, and place the frame in gear by raising it with the finger, when the succeeding cut is made.

The advantages effected by this arrangement are very great, and have been highly appreciated by many amateurs who have used the self-acting rest.

The leading screw being driven from the overhead motion, both hands of the operator are perfectly free. In turning a cylinder, the relative speed of the lathe-mandrel and the traverse of the slide is always the same, whether the fly-wheel be driven slowly or quickly, and the same remark applies to the use of drills, or any of the cutters used in the different instruments; and thus all cuts, flutes, and mouldings are produced with great exactitude, and the operator is freed from the close attention otherwise required.

We pass now to the improvement in the upper slide, which carries the various tools and revolving cutters, affording greater facility in its use, and producing a mathematical precision in depth of cut, and consequent beauty of finish to the work.

The receptacle which holds the tool is constructed in the same manner as the ordinary rest, with the exception that the stop-screw and pillar, also the projection through which the screw passes on the right side, are done away with entirely, and only one screw

is necessary. By reference to the outline engraving, Fig. 17*, and letters thereon, the following details clearly indicate the advantages claimed by the improved action:—

The screw, M, as will be seen, is of increased length, and works through the projection on the left side of the tool-box, its end passing through a frame, A, and cast in the solid, with the slide also marked A. On the

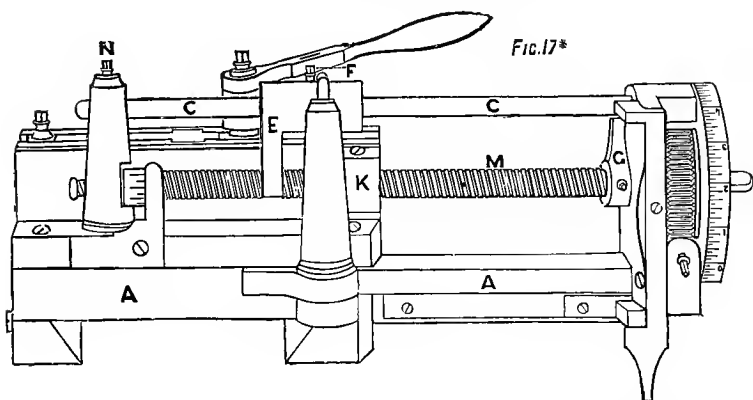

end of the screw a micrometer $2\frac{5}{8}$ in. in diameter is fitted, divided into hundredths of an inch, each division being again sub-divided by ten, so that each sub-division on the micrometer indicates one thousandth.

The front end of the screw has a collar fitted to it, bearing against the pillar, which is filed away to a flat surface to better accommodate it. A steel bridle, the same as in the other rests, is fitted to retain it in its

place, but can be easily detached when not required. A steel rod, *c c*, $\frac{3}{16}$ in. in diameter passes from the pillar to the frame, *A*, at which end a collar $\frac{7}{16}$ in. in diameter is countersunk into the frame, and retained there by a small spiral spring.

A gun-metal clamp, *E*, is fitted to slide on the rod, *c c*, and is fixed at any desired point by a set-screw. The clamp is made semi-circular at the bottom, and is made to pass freely over the external diameter of the main screw.

A small steel arm, *G*, is fitted on the plain part of the screw, close to the face of the frame, *A*, and is fixed by a set-screw when finally adjusted for work.

The adjustment and action of the apparatus thus made is as follows: The cut having been made to the required depth in the work by the gradual advance of the tool by means of the screw, *M*, the rod, *c c*, is pushed forward till the collar protrudes from the frame about $\frac{1}{20}$ in., and is held by the set-screw, *N*, through the top of the pillar; the clamp, *E*, is then placed in close contact with the projection on the tool-box, and fixed to the rod, *c c*, by its set-screw. The steel arm, *G*, is then turned round on the plain part of the screw till arrested by the collar projecting from the frame; the set-screw, *N*, is then released, when the tool can be withdrawn to any extent; and on again advancing it, the rotation of the screw is arrested at precisely the

same division of the micrometer at which it stood when the first cut was made, and the reason why such accuracy is obtained is manifested by the simplicity of its action.

Thus, the clamp, E, being fixed, the rotation of the screw, M, causes the wing of the tool-box to come in contact with it, drawing out the collar from the frame until further movement of the screw is prevented by the steel arm, G, which is fixed to it. The advantage in this arrangement is, that the propelling power and the stop both act in the same line, consequently there is no diagonal strain; and further, one hand only is required in its use. When worked in combination with the automatic fluting stops on the main slide, the work is executed with great accuracy in much less time than when done without their aid.

In concluding the remarks upon the slide-rest, it will be necessary to refer to that class of rest illustrated by Fig. 18, which is for the purpose of metal turning, and is also a most useful tool in the preparation of large and rough pieces of material, such as African blackwood, ivory, or in fact anything that may be considered beyond the capacity of the lighter slide-rests previously described. A stout gun-metal cradle is first fitted to the bed of the lathe, one side being planed to an angle, the opposite being square, with a steel strip between it and the cast-iron base, a screw

passing through the side of the cradle to retain the rest always at a right angle to the bed. In the face of the lower slide a tee-groove is turned out, and in the centre of the plate a projection is left on which the main slide fits and revolves ; two steel bolts with tee-heads are fitted to the groove and pass through two round holes in the base of the top slide, being tightened by hexagonal nuts with washers. This way of fitting up such a

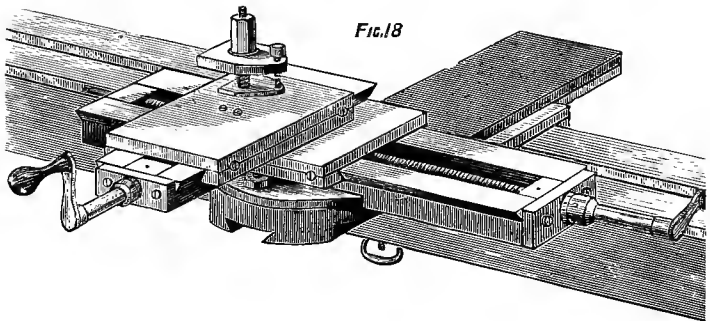

slide-rest is vastly superior to the original method, which consists of quadrant slots only, that simply admit of the rest being turned to a limited angle ; and if required for surface work the two bolts must be removed and replaced in different holes, or the cut must be taken over the surface with the top slide when moved to the extreme end of the lower slide. With the improved action which the author now adds to this particular slide-rest, by slackening the two nuts

it can at once be moved to any desired angle, from its position of parallel to the lathe-bearers, to a right angle, or transversely across the bed to turn a surface ; all of which are denoted by a divided scale.

The main slide is made longer than usual, which is found to be of considerable service, and is fitted with a screw of ten threads to the inch, carried through at the end in order that the spiral apparatus may be adapted at any time. On the top of the main slide another one is fitted to work at right angles to it, for the purpose of setting in the depth of cut, and this is fitted with Professor Willis's tool-holder, provided with an extra long centre-pin so that vertical slides or other useful adjuncts may be employed. The main screws are both covered, although not shown ; this is to prevent the shavings and dirt getting to them, and prevents much wear. The handles are fitted to the screws on a slightly taper fitting with a transverse mortise, and are divided close to the end into ten equal parts, and a line marked on the plate ; this is a most useful addition for many purposes, especially screw-cutting.

Both for this latter purpose, and also in ornamental turning, it is most desirable that the starting-point for all work requiring lateral traverse should commence at the zero on the micrometer, and in most cases it happens that the work and cutters are adjusted without reference to this, and not noticed until the tool is

required to be moved in that direction, and to re-adjust it the micrometer can be set to zero and the slide-rest moved bodily along the bed until the point of the tool at its starting-point agrees with it. The necessity for this movement is avoided by having the micrometer fitted with an adjustable index, which may be turned round until the 0 agrees with the reading line, no matter in what position the slide-rest is fixed.

It is made in the following manner: The end of the screw is turned down, leaving a projection slightly beyond the metal plate; a ring of metal about $\frac{3}{8}$ in. wide is carefully fitted; the micrometer is then fitted to the same shaft, and beyond this a fine thread is cut and a milled head-nut to fit it, so that when any alteration in the position of the figures is required the nut is loosened and the index turned to the desired line, when the nut is again fixed. The winch-handle is fitted in the ordinary way, and does not interfere with the arrangement in the least. This power of adjustment is most valuable, and is now fitted to many of the best slide-rests.

The loss of time, or back-lash, inherent with most screws, especially those with square threads, is a feature which causes great annoyance to turners; and much, if not all, is to be avoided by the nut through which the screw passes being provided with properly fitted adjusting-screws. The wear to such a screw will

in time admit of the nut being moved laterally upon the screw without rotating the winch-handle ; therefore, when the screw is turned it moves a certain distance without carrying the slide. This is of more serious consequence when the rest is connected to the spiral apparatus, as, in such an instance, the work also partially rotates without the corresponding lateral movement of the slide. This will receive due reference in the chapter devoted to spiral turning.

To avoid such loss of time, the nut should be severed about $\frac{1}{2}$ in. from one end, before doing which, two holes, one each side of the screw, should be drilled, and that in the deepest portion of the nut tapped to receive the set-screws ; the front is then counter-sunk to receive the heads. It will be seen by this, that by setting up these screws the nut is tightened between the thread and space, in consequence of which no end-play can occur, and, if carefully adjusted, no loss of time in the screw need remain. It has been found to answer in every way, and no slide-rest should be accepted without being thus fitted.

CHAPTER XII.

SLIDE-REST TOOLS AND CUTTER-BARS.

THE ordinary tools made from square steel and forged at the end to the shape required are now seldom used except for special purposes, the cutter-bars of various descriptions having superseded them, and these, especially for amateurs, are a very considerable advantage, as they have short exchangeable cutters which are more easily ground, and do not require forging. The first of this class which bears special reference to the requirements of those who practise the art of plain and ornamental turning is the gouge cutter-bar (Fig. 19). The stem is made to fit the tool-box of the slide-rest, the front is bent to a suitable angle, so that the gouge, when placed in contact with the semicircular front fitting the hollow of it, will be presented to the work at the correct angle for cutting soft woods; a steel strap passes over the frame and round the exterior of the blade, and a screw through the top fixes the tool firmly; by releasing the screw the gouge can be adjusted to the height of centre. This has proved to be

a most valuable adjunct, and for roughing over large material may be considered indispensable. A corresponding bar is made to hold flat chisels, but this is

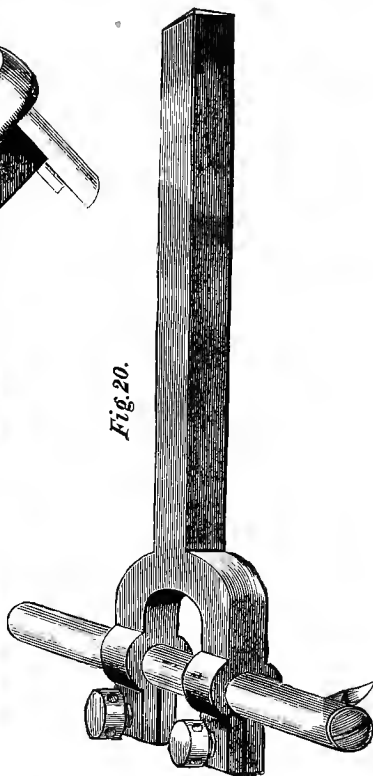
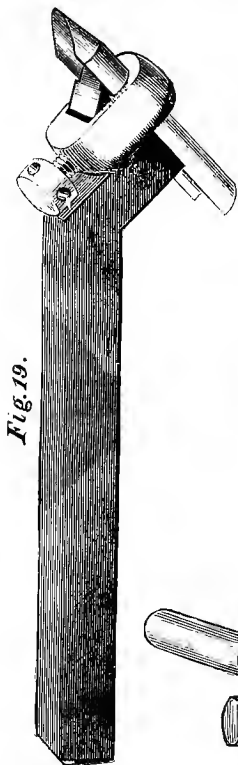

limited in its use, and has a decided propensity for intruding its corners, greatly to the detriment of the work. It is therefore of little service, and not to be

recommended, and the gouge previously alluded to, if keenly sharpened, will produce a surface as smooth as it is possible to require it.

Fig. 21.

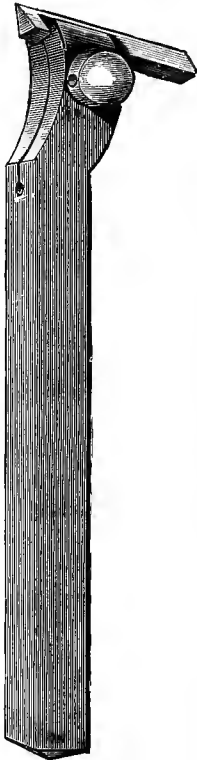

Fig. 20 illustrates a cutter-bar necessary to the turning or boring of deep cylinders or internal work, and it has many advantages. The stem in this case is made to fit the tool-box, and is forked at the end, so that a cylinder bar may pass through it at right angles to the stem. At the end of the rod a cutter is fitted, at such an angle that its cutting point is just beyond the end of the screw which fixes it in the centre, and is identical with the axis of the lathe; this at the same time is adjustable by turning the rod in whichever direction is necessary, and fixing it by two screws as seen in the engraving.

When using this tool, deep internal work may be performed without turning the slide-rest round to the surface, and the full depth of the cut taken by one continuous movement of the main screw of the slide-rest;

thus, supposing a deep box is desired, the exterior is turned with an ordinary tool or cutter-bar, as may be considered best. It is then required to turn out the inside, and by placing the cutter-bar (Fig. 20) in the rest it is done with considerable facility by one continuous cut. To effect the same object without its aid, the slide-rest must be placed transversely across the lathe, and the tool inserted by the depth and stop-screws, the capacities of which are, in many cases, insufficient for the depth of work. It will be seen that the rod which holds the tool may be increased in length, or reduced if less extension is necessary. For such work it is a most important addition, and is now largely used. It was invented and introduced by the author.

Fig. 21 is a cutter-bar designed for metal turning. The stem is fitted in the same way; in the front a triangular hole is filed at the necessary angle; the cutters are easily made, and may be adjusted to height of centre. The edge may be sharp, round, or flat, to suit



Fig. 22.

the material to be operated upon, and by grinding the top face, a more or less acute cutting angle is obtained. This tool, although appropriated to metal-turning as a

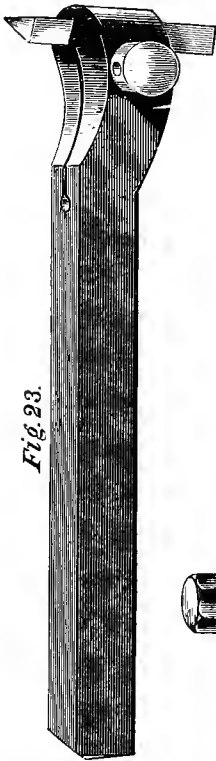
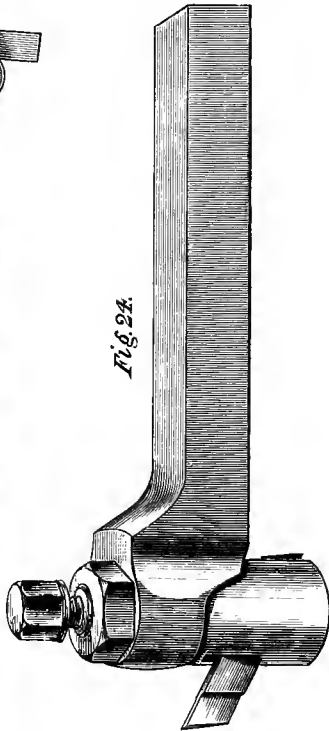
*Fig. 23.**Fig. 24.*

rule, may be applied to roughing-over ivory of uneven surface, which is more easily done with a sharp pointed tool.

Figs. 22 and 23 are tools for the same purpose, but bent in opposite directions, so that the cutting edge is presented to the right or left side of the work, and for such work as require their services they are most useful tools. The engravings show clearly what they are intended for; they therefore need no further explanation.

Fig. 24 is a very ingenious universal cutter-bar, invented by Mr. Garvin Jones, and supplies the three in one. It will be observed that at the front of the stem a socket is fitted, which carries the tool at the correct angle; on the top a nut with a left-hand thread is fitted, and when this is released the tool may be set to the front to turn a cylinder, or to either side for face work, when it is fixed by a screw at the top with a right-hand thread. This is a very useful tool, and is largely used in factories. It is also employed with excellent results in the planing machine. They are made as large as 2 in. in the stem for very heavy work. There are very many descriptions of cutter-bars, but further reference is unnecessary, as those already detailed will be sufficient to establish the excellence of such forms over the original fixed tool.

CHAPTER XIII.

TOOLS APPROPRIATE TO THE ORNAMENTAL SLIDE-REST.

THE general advance in the improvements connected with the ornamental turning slide-rest gave rise to an equally valuable rearrangement of the necessary tools to be employed in it. The slide-rest, in the early period of its history, having screws of indefinite value, bore no reference to the tool beyond moving it a certain distance laterally.

The introduction of a screw of aliquot value renders the slide-rest more easy to manipulate, combined with the great advantage of as near absolute accuracy as possible, and the various tools now to be described are all made of definite widths in hundredths, so that the lateral traverse of the slide will carry them precisely their own width; as an instance, a tool $\frac{10}{100}$ in. wide will by one turn of the screw be moved through the space of its cutting surface, while one half-turn of the screw effects the same on a tool $\frac{5}{100}$ in. wide. This has been referred to with respect to the details of the slide-rest in previous chapters, and will from time to time

during the descriptions of the various specimens receive further notice.

Before using the small slide-rest tool as illustrated, the material should be reduced to approximate form by stronger tools, such as the gouge cutter-bar (Fig. 19), either in the ornamental slide-rest, or, if the work is of very large diameter and proportionate unevenness, it is

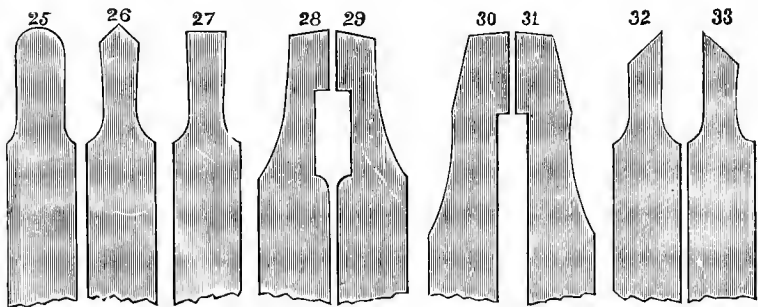

preferable to employ the metal-turning slide-rest (Fig. 18), as the lighter one, from its construction, is likely to be somewhat disorganized by being subjected to work beyond its capacity.

Fig. 25, the first of this class of tool, is a round-nosed tool, and is used for turning concave curves and hollows of different shapes. It may be mentioned that all the tools to be described are made in sizes from $\frac{5}{100}$ to $\frac{30}{100}$ or $\frac{35}{100}$ in. wide, and at times of even greater width, and are now made of one uniform length of 3 in.,

in preference to the original plan of decreasing the length in proportion to the blade.

Fig. 26, a double angle or point tool. This is largely used for cutting or tracing the very fine surface patterns, produced by the ornamental chucks in combination. It is also employed for graining the surface of the work previous to its being ornamented, and for

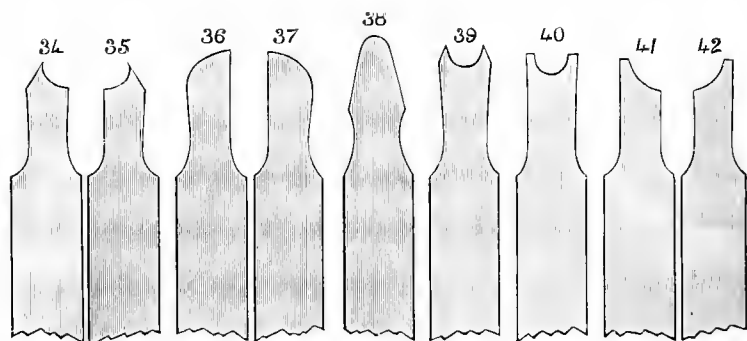

cutting deep V or angular grooves; it has also many other purposes.

Fig. 27 is a square end, otherwise a chisel, also applicable to a variety of work. For cutting steps or recesses it is found very handy; it is made to cut on both sides, and may be used to finish the interior of a box-lid, and by withdrawing the cut carefully the fitting may also be finished at the same time.

Figs. 28 and 29 are right- and left-hand side tools; they are used principally for excavating boxes or

similar articles. The ends are ground to a slight angle, to leave the point prominent, so that the cut may be carried quite into a corner and made square with the surface at its base; for instance, the surface having been turned, when the tool arrives at the internal diameter the tool is withdrawn, leaving the work perfectly clean and sharp.

Figs. 30 and 31 are tools of a similar description, but made on an improved plan introduced by the author; and the advantage of being thus constructed consists in the cutting edge projecting at the side, so that the depth to which they can be inserted is not limited as in Figs. 28 and 29, which it will be seen have the cutting edges level with the shaft of the tool. In this form they can be ground away until the projection is nearly gone, and still penetrate as deeply as before. They are now made in this way, and found to supersede the original shape.

Figs. 32 and 33 are right and left single angle tools, made to a variety of angles to suit the various works; these are also employed for surface patterns and cutting angular recesses, and for many purposes connected with plain turning.

Figs. 34 and 35 represent quarter hollows, right and left with pointed terminals, and are necessary to the production of corresponding quarter rounds, and are much used to obtain the form of the work previous

to its being operated upon by a drill or other cutter for seriated mouldings.

Figs. 36 and 37 are the reverse of these, being quarter round, right and left; therefore their employment results in the production of quarter hollows. These are also most useful for turning portions of mouldings, which may afterwards receive further decorations by the corresponding tools of shorter length, revolving in any of the several cutter-frames.

Fig. 38 illustrates one of the most useful of this series of tools, and is called a roughing or routing tool. It is employed for a number of different purposes, notably for turning down long cylinders or shaping up work with curved ends; it is also a tool particularly essential to the spherical slide-rest, as it cuts more cleanly during its descent round the sphere, consequent upon its cutting edge extending round the sides. It is necessary also when using the curvilinear apparatus, as the continued curve of the front enables the tool to be more easily traversed over the undulations of the template.

Figs. 39 and 40 comprise two important factors—namely, bead-tools, Fig. 39 being pointed at the end, while Fig. 40 is astragal, or square. They are used in the production of beads of various sizes, either in close proximity or distant one from the other. The result of the two kinds is very distinct.

Figs. 41 and 42 are similar to Figs. 34 and 35, the only difference being that they are astragal at the end instead of pointed.

Fig. 43.—In this tool, which is a double quarter hollow, especial use is found when employed in conjunction with the dome-chuck, for cutting reeds in close proximity, that is of course when a fixed tool is preferred. But, as will be pointed out in future

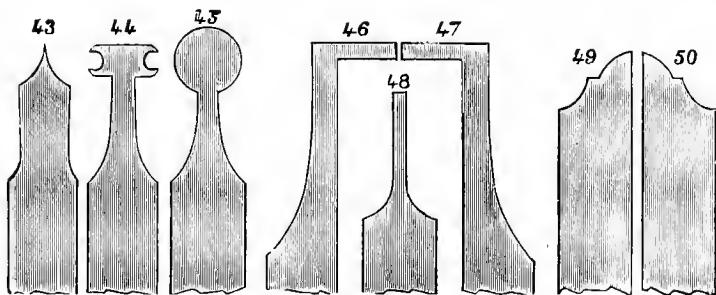

chapters, the same result is better obtained with a revolving cutter of the same description. When placed in the socket-handle (Fig. 60), it may also be used as a hand-tool for a large variety of purposes.

Fig. 44 brings before our notice a tool which is necessary to the turning of rings, and is therefore termed a ring-tool. It will be observed that it has two semi-circular cutting edges, one on each side of the shaft, and these identical in form. To turn a number of rings that may be required all alike, the material is

bored to a tube the size of the inside diameters. The tool is then inserted while the slide-rest is at right angles to the bed, the depth being decided by the stop-screw of the top slide; it is then penetrated laterally into the material by the screw of the slide-rest, until the form of the bead is cut; it is then withdrawn and passed to the outer diameter, the same depth being maintained. The cut is then carried back in the

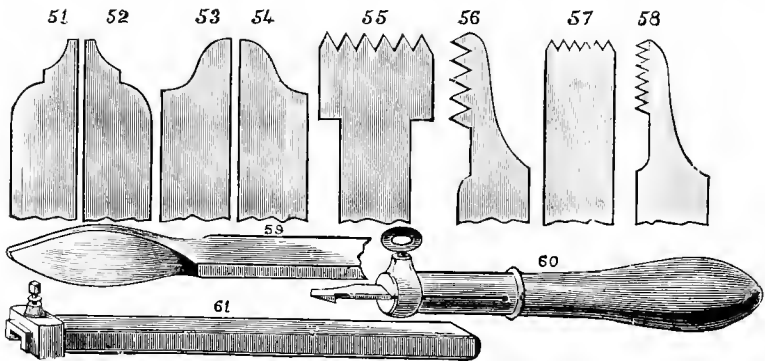

reverse way, and when the bead is cut on that side, the ring will be detached and perfect in shape. In this way, employing a series of different-sized tools, the chains forming part of the candelabra, described in a subsequent chapter, were made.

Fig. 45, a ball or spherical tool, is used principally for undercut or for shaping concave curves, and may be found of equal service either in the slide-rest or as a hand-tool.

Figs. 46 and 47 combine the right and left side parting tools, and are devoted to the cutting out of rings, and, in the case of ivory being worked, they are a means of saving a deal of valuable material. As an instance, assuming that a large and solid piece of ivory is to be shaped, from which much of the interior is to be removed, the same may be cut out in substantial rings, which are always worth saving. To effect this, the ivory is turned out at the centre to admit the blade of the tool (Fig. 47); it is then inserted by the guide-screw to the depth required, and by the lateral traverse of the slide-rest the blade of the tool is carried into the material its own depth, or less, according to circumstances. The tool is then removed, and with the front parting tool (Fig. 48) it is cut through from the face opposite the end of the incision made by Fig. 47, when the ring will be released. In some instances it is necessary to remove the substance from the margin of the work, and not the centre. The same process is then performed with the opposite tool (Fig. 46). These tools are made of various widths and lengths. When of considerably less dimensions than those illustrated, and with rounded points, they are used to recess the back of an internal screw.

Fig. 48 is simply a parting, but when made of a short and appropriate length it is used as a fixed tool in the slide-rest for cutting the different

patterns illustrated on Plate 7, executed by the eccentric chuck.

Figs. 49, 50, 51, 52, 53, and 54 are examples of figure or moulding tools. These require to be very carefully made, and render some very beautiful forms, which may be then cut with corresponding tools of less length, revolving in the several instruments, such as the horizontal, universal, or vertical cutters. In the first named, the tools may be applied in their full length. Those illustrated are only a very few of the different shapes that are made, but they will serve the purpose of explaining their employment.

Figs. 55, 56, 57, and 58 are illustrative of the screw-chasers, which are made to match the screw-guides of the traversing mandrel, and for cutting short screws are of valuable assistance. These, also, are largely employed as hand tools.

Fig. 59.—In this we have a parting tool constructed to withstand considerably more pressure than Fig. 48 is capable of resisting. It was introduced by the author at the suggestion of an amateur turner, who fractured many of the original plan, and it has been found most satisfactory. By reference to the engraving it will be seen that the blade not only extends below the shaft or stem of the tool, but above in a similar way, thus creating a resistance against the pressure of the work as it revolves. The cutting edge is still

maintained in a line with the surface of the tool, and no alteration is required with regard to the height of centre. As a proof of their excellence, it is found that, though many are made, few become broken.

Having concluded the few remarks essential to the introduction of these tools, the socket-handle (Fig. 60), which forms the means of employing them as hand tools, is now to be explained. The metal socket which holds the tool has a mortise-hole of the required size made in it; it is then cut through the centre into a hole drilled through the end near the handle; a steel ring with a fixing-screw is then fitted to the end, so that when the tool is placed in the slot it is readily held by the screw. This handle is a very necessary adjunct, and by its aid the tools already described can be used for a double purpose.

The tool illustrated in Fig. 61 is made so that it may be extended in length to a greater distance from the slide-rest, which at times it is necessary to do. A steel bar is made to fit the tool receptacle, and planed out at the end to receive the tools, the recess being deep enough to allow the face to draw up to the same centre as if placed in the tool-box. To fix the tool a steel strap is fitted over the stem, and will move to any part; a steel binding-screw passes through and holds the tool firmly in its place.

CHAPTER XIV.

THE ECCENTRIC CUTTER.

WHEN the art of ornamental turning is commenced it is generally the eccentric cutter, the drilling instrument, and the vertical cutter that first claim attention, and form the primary study.

The intention of the author to pass by the group of fine-line decorative patterns confined to the surface only, and upon which much has been written in works already published, has been referred to in the introduction. It remains, therefore, to proceed at once with the detailed description of the manufacture and manipulation of the instruments that are to be employed for the more advanced work, comprised in the formation of elegant designs, compound solid forms, polygonal figures, caskets, etc., which are endless in variety, and afford a most interesting pursuit.

The eccentric cutter (Fig. 62) is constructed in the following way: A square stem is fitted to the tool-box of the slide-rest; it is then bored through, and turned out at each end to receive two steel-hardened collars.

A steel spindle, to which is attached a right-angle slide, is then accurately fitted to revolve in the stem. On the rear end a steel pulley is fitted, having in the front a collar with a cone to fit that contained in the collar in the stem. The pulley is held to the spindle by a flat on the end, and a screw in the spindle. The right-angle slide is made to carry a small tool-box or

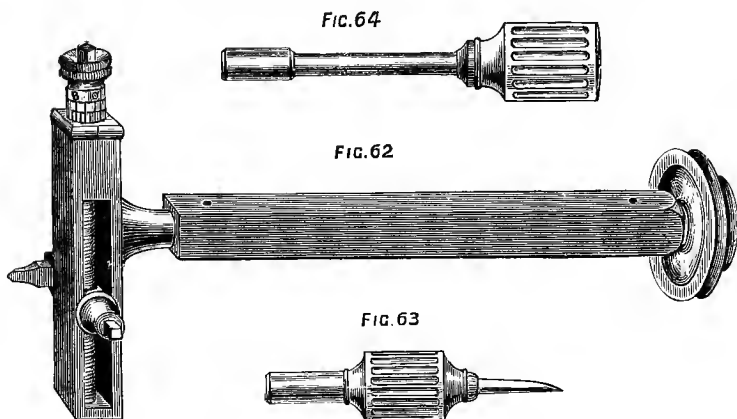

receptacle to hold the various tools as required. This is actuated by a main screw of equal value, 10 threads to the inch, but from the fact of its being so small in diameter it is necessary to make it a multiple pitch; consequently it has four threads. To the opposite extremity of the tool-box a steel washer and clamping-screw are fitted. The main screw is retained in its place by a metal plate fitted to the slide, against which

the collar on the screw bears. A metal micrometer is then fitted to the screw, and divided into 10 equal parts, which read to $\frac{1}{100}$ of an inch; it is again subdivided with intermediate short lines to read to $\frac{1}{200}$ of an inch. By these divisions it will be seen that the tool may be moved along the slide in equal ratio with the slides of the eccentric and other chucks, etc. The centre of the instrument is coincident with the axis of the spindle, the face of the right-angle slide being filed to the exact half, and when the tool is fixed in the centre, which for testing purposes should be a double angle, it will cut a minute dot upon touching the work. The zero line on the micrometer must then correspond with the index line on the end plate of the slide.

The value of the screw being 10 to the inch, it will be noticed that each complete turn will move the tool $\frac{1}{10}$ of an inch from the centre, three turns $\frac{3}{10}$, and so on; the tool cutting a circle double the size of the radius to which it is extended; for example, if the tool is advanced three turns of the main screw, the circle cut would be $\frac{6}{10}$ of an inch in diameter, if moved ten whole turns the circle will be two inches; the proportion being, of course, the same if the movement is divided by the intermediate lines on the micrometer.

When setting out the radius of the eccentric cutter for any particular pattern, it must not be forgotten that it refers to the tool at its centre line. For instance, a

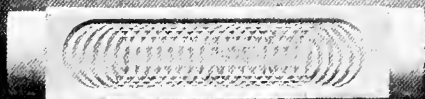
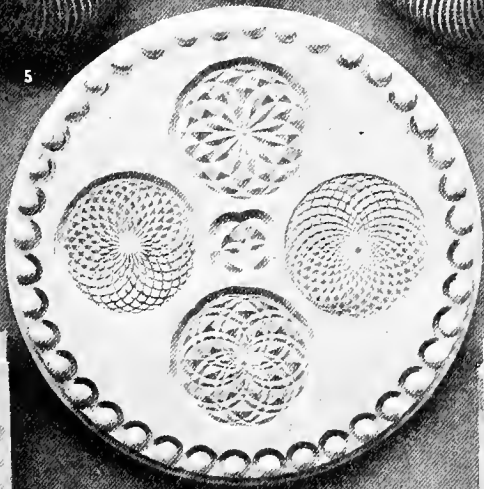
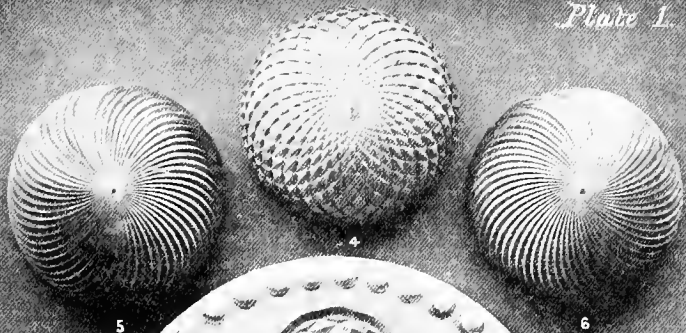

moulding tool similar to any of those from Figs. 82 to 93, set out $\frac{5}{10}$, would cut a circle 1 in. in diameter at its centre, therefore the extra width of the tool must be considered when adjusting the radius; that is, if the extreme diameter is required to be 1 in.

The eccentric cutter is also largely used when decorating black wood with ivory, as it is capable of cutting out larger circles than can be effected by a drill.

A further development of its resources is found in its application to the shaping of square, hexagonal, and polygonal figures, both on the surface or in the form of pillars, etc. Plate 1 illustrates a few examples of this class of work. Fig. 1, in the first place, is reduced to a cylinder $1\frac{1}{4}$ in. in diameter, and turned down at each end to $\frac{7}{8}$ in. in diameter, or just below the sides of the square; when thus turned the eccentric cutter is placed in the slide-rest, having a round-nosed cutter (Fig. 70) in the tool-box; the eccentricity is set out by the main screw of the instrument to cut a circle sufficiently large in diameter to bring up the corners of the square. When so far adjusted, the cut should be inserted by the depth screw of the top slide, and then traversed the entire length of the material by the main screw. It will be obvious that, by rotating the pulley a fourth of its diameter, and repeating the process each time, a square is produced; should the corners not be quite

sharp, the eccentricity must be slightly extended and the cut carried deeper. So far we shall have produced a plain square, but, by reference to Fig. 1, it will be seen to have a series of cuts, each deeper and less in length than the first. To effect this, the eccentricity must be reduced to cut a circle the size of the recess required; the fluting stops are then employed to arrest the cut at each end, by which it will be observed the end of each is left circular, the diameter of the circle depending upon the radius the tool is cutting. To cut the second step the eccentricity is again reduced, and the tool advanced to the necessary depth. When cutting out the recesses the round-nosed tool is replaced by one with a square end; and the process repeated four times.

Fig. 2 represents a different pattern. It was in the first place cut to a plain square, then recessed in the same way as Fig. 1; it was afterwards cut in the following manner: the eccentricity of the cutter slightly extended, and the tool inserted to the depth of the first step; the first cut, therefore, will be when the tool is arrested by the fluting stop, in which case the micrometer on the slide-rest screw should stand at zero, or the number at which it does point should be noted; the tool is then withdrawn and moved laterally by the main screw of the slide-rest two whole turns, $\frac{2}{10}$, and the second cut made; this is repeated along the whole

length of each step. When the four are thus cut, the eccentric cutter is removed, and the drill-spindle substituted having a bead-drill $\frac{1}{100}$ wide. The drill is returned to the centre of the first cut, being arrested by the fluting stop; it is then penetrated to the depth required to bring up the bead, and is inserted at every second turn of the main screw. It will be seen at a glance the wide difference in effect obtained by this comparatively simple alteration in the manipulation of the instrument.

Fig. 3 is again varied, and although a very simple pattern to produce, is most effective. As in the two former cases, it is first cut to a plain square, after which a double-angle tool of 45° is used in place of the round-nosed tool, the diameter of the circle reduced to the required size, and the tool inserted to bring up the pattern sharp, the lateral movement of the screw being one turn, $\frac{1}{10}$. This kind of pattern may be extended to a large degree by various alterations in the movement of the main screw; for example, take the first cut and move the screw one turn, or $\frac{1}{10}$, withdraw the tool, and for the next cut move the screw $\frac{1}{20}$, or half a turn, and cut again; for the third cut move the slide $\frac{1}{10}$, and repeat the movements alternately. The intersection of the circles at varying distances is most effective, and very beautiful effects result from such combinations.

We have thus far considered the eccentric cutter, as

applied to the shaping and decorating of square pillars, etc. It is desirable now to take a brief view of the same instrument when used for the ornamentation of the surface by deep cutting, and the four primary examples illustrated in the centre figure of Plate 1 will suffice to demonstrate the fact that a wide difference is produced by a very simple alteration in the adjustment of the settings. This particular subject affords an opportunity of explaining the manner in which the four examples are so placed by the aid of the eccentric chuck, which will receive further demonstration in a future chapter.

In the first place the work is mounted on the eccentric chuck, carefully surfaced with a sharp tool, and polished. The slide of the chuck is then moved out $\frac{11}{10}$ —11 turns of the main screw—to enable the four separate patterns to be placed as seen in the illustration. Having set out the slide of the chuck, the tool is moved towards the operator $7\frac{1}{2}$ turns, which will cause it to cut a circle $1\frac{1}{2}$ in. in diameter. This is repeated at each quarter of the dividing wheel, 96, 24, 48, 72. The fixed tool is then replaced by the eccentric cutter, and a double-angle tool of 40° employed. The first of the four (Fig. 1) is an extremely simple example, and is generally known as the barley-corn. There are twelve consecutive cuts, the division of 96 on the dial-plate being used, arrested at every eighth hole, the tool being

allowed to penetrate $\frac{3}{20}$ deep, which will bring the points of the pattern to the shape required.

Fig. 2, it will be observed, is different in its appearance, through a simple alteration in the adjustment of the division. It is cut with precisely the same tool and the same amount of penetration, but first cut at every twelfth hole of the same circle; the dial-plate is then moved forward two holes, and the tool again inserted at every twelfth hole from that point, thus rendering the pattern as seen.

Fig. 3, it will be noticed, differs widely again, a left-side tool of 55° (Fig. 67) being employed, while every fourth division is used, by which twenty-four cuts result, the angle on the outer diameter being caused by the figure of the tool being presented in that direction.

Fig. 4, it will be seen, presents all the points in exactly the reverse direction, which is caused by simply replacing the left-side tool by a right-side of the same angle (Fig. 68); the latter being on the reverse side to that which cut Fig. 3, the outer diameter is carried in square. These four patterns, simple and comparatively insignificant as they are, will be all that are required to illustrate the action of the instrument for such work, and it is almost needless to say the variety may be extended to any degree. The circle of large beads round the edge of the box-lid were executed with a

bead tool, also used in the eccentric cutter, being set, of course, to the centre of the instrument, in which case it answers the purpose of a drill and effects a similar result. The same may be cut with a drill if preferred, but these examples were cut entirely with the eccentric cutter to illustrate its capabilities.

Following the various uses that this instrument may be devoted to, we arrive at its application to the dome or hemisphere, and on such forms very beautiful work is produced. In this class of work the tool may be used to shape up the work to a very great extent in the first instance.

Fig. 4, Plate 1, may be styled the primary example of this description of ornamentation. To proceed with work of this character, the material should be first roughly shaped by hand-turning to the form required; presuming that a hemisphere is desired, after the form is roughed out, the eccentric cutter with a round-nose tool is placed in the slide-rest, the eccentricity extended to cut the diameter of the dome, and the slide-rest turned to an angle of 45° . The tool is then advanced to remove as much material as is necessary, and revolved at a high speed while the work is slowly rotated by hand, or preferably by the worm-wheel and tangent-screw of the segment apparatus; by this operation it will be found that the bare form is accurately shaped. The eccentricity is then reduced, and a double.

angle tool of 55° substituted for the round-nose one. To cut such a pattern, the slide-rest must be set to bring the tool very accurately to the centre of the lathe-axis, in order that all the points may radiate to the centre.

Fig. 5, it will be observed, is of a totally distinct character, prepared in the first instance in exactly the same way, the slide-rest being set to the same angle; which is necessary in all cases where a hemisphere is to be ornamented. The slide-rest for the pattern under notice is then elevated $\frac{1}{10}$ above the centre of the lathe-axis, and a single angle tool, left side 55° , used in place of the double angle. The penetration must be only sufficient to bring the edge of the figure up sharp, or the true form of the hemisphere will be destroyed.

Fig. 6 will show most clearly that a very small and simple alteration in the arrangement of the tools will give a wide range of effect in the figure produced, and as in the present case it is only to depress the tool to $\frac{1}{10}$ below the centre instead of elevating it above, there is really no further explanation necessary with respect to these primary examples of the productions of the eccentric cutter. When adjusting the tool above or below the centre, it is necessary to do so in accordance with the depth of cut required. If the tool is allowed to penetrate deeper than the depression or

elevation will admit, without touching the opposite side, the desired effect will be destroyed.

The eccentric cutter is also largely used, in conjunction with all the ornamental chucks, for the shaping and ornamenting of compound solid forms, and will be again referred to as the subjects are approached.

CHAPTER XV

ECCENTRIC CUTTERS.

THESE tools are illustrated by Figs. 65 to 81, and it will be seen in most instances they are precisely similar in form to those previously described as appertaining to the slide-rest. They differ, however, in size, being made to fit into the tool-box of the eccentric cutter. Although they will be recognized in form as similar to those already described, they have each a widely different part to perform when employed for the purposes for which they are intended. They vary in width from $\frac{3}{100}$ to $\frac{25}{100}$, in some cases even wider, being extended beyond the stems, but this would only be required for a special purpose.

Fig. 65 is a double-angle tool largely employed for surface patterns, either of a light and shallow character suitable for printing, etc., or for the deeply cut barley-corn pattern illustrated by Figs. 1 and 2 in the centre of Plate 1. They are usually made about $\frac{1}{100}$ in. wide at the cutting portion, and ground

to various angles, from 10° to 60° , and are marked on the face to denote the angle or width, as seen in Figs. 65 to 79.

Fig. 66 is of the same character, but for some purposes is very much more useful from the fact of its being made to cut at the same angle its entire

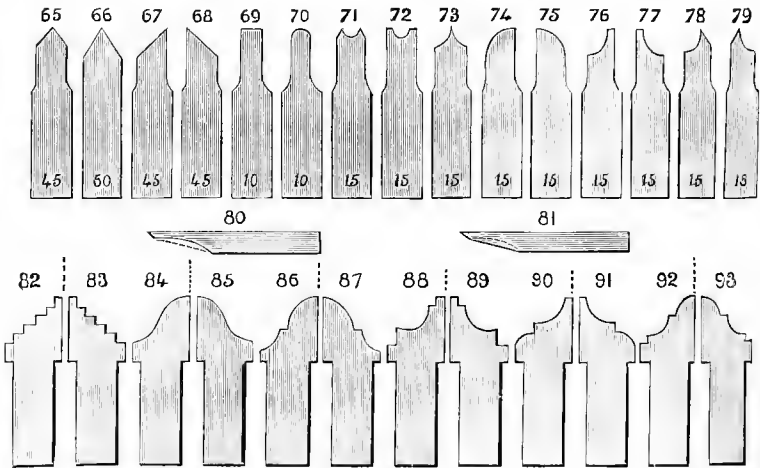

width. In cutting a very deep pattern it has been found that the limit in the width of the blade is a distinct disadvantage, and that the pattern could not be brought up in consequence of the side of the tool penetrating the work and so destroying the figure required; therefore, in many instances, Fig. 66 may be employed with much better result, as the

cutting edge has the angle carried through the whole width.

Figs. 67 and 68 are right and left single-angle tools, and although in most instances applied in the same manner as Figs. 65 and 66, the result obtained is of a distinct character. This will also be seen by reference to the centre medallion in Plate 1 ; as already intimated, Fig. 3 was cut with the left-side tool (Fig. 67), while Fig. 4 was executed with its companion (Fig. 68). Now, the result of the two tools is, that the terminal points are directed in different ways, equally effective ; but at the same time the variation is so apparent that it shows the opposite character of the tools and enables them to be used for distinct purposes.

Fig. 69 is a chisel, or square-end tool, and valuable for smoothing surfaces or recessing the fillets of moulding on square pedestals. These tools are also made from $\frac{3}{100}$ to $\frac{25}{100}$ in. wide, and should cut on the sides as well as on the ends, the cutting edges being well relieved. Such a tool would be used to recess the square pillar seen in Fig. 1, Plate 1, also Fig. 2 in the same plate, and is of equal service for such patterns as are illustrated by Plate 2 when it is placed in the small saddle (Fig. 96).

Fig. 70, being a round-nosed tool, is of great service for roughing out the bare form, whether it is a hemisphere, square, hexagon, or any other shape ; and is

much used in the vertical or other revolving instruments when shaping up mouldings, either of a continued or seriated form.

Figs. 71 and 72 are tools that are continually in use in ornamental turning, and may be used in the various revolving instruments, but are more generally employed in the universal cutter when used in any of its obtainable positions. They are a most essential tool to this instrument when employed for reeding columns in connection with the spiral apparatus, or for straight reeds. Reference will be found with respect to these, as having also been used in the vertical cutter for the patterns illustrative of that instrument in Plate 2.

Fig. 73, a double-quarter hollow, is, perhaps, one of the most difficult tools to make in a perfect form. This is also used for reeding in various forms, especially where the reeds are required in close proximity, and it will be found that in cutting a taper shaft, or hemisphere, that the gradually varying diameter causes the shape of the reed to be different at the centre, or smaller than it is at the margin. This does not destroy the effect, however, and is explained simply that it may not be regarded as an error. It is necessary to be very particular when spacing the work, in order that the full quadrant of the tool, and that only, may be employed; if only a portion of it is allowed to cut, the reed will be more of an elliptic shape, and not semi-circular.

Figs. 74 and 75 represent quarter-round tools which are necessary for the production of various mouldings, and are used in the horizontal or universal cutter; they are available also for cutting long continuous mouldings, by the traverse of the slide-rest, or for seriated scollops; they are also used in the eccentric cutter, where the terminals are required of their shape.

Figs. 76, 77, 78, and 79 are the quarter-hollows, pointed and astragal, employed for a similar purpose to Figs. 74 and 75, but to produce the reverse forms, and are indispensable for many mouldings.

Figs. 80 and 81 represent the side views showing the manner in which the back of these tools are shaped. Fig. 80, it will be seen, is hollowed at the back of the blade: this is to reduce the friction as much as possible, and is advantageous when only light work is required of it; but Fig. 81 shows an improved form, which is simply filed at an angle. The dotted line, representing the curve given to Fig. 80, shows clearly the amount of substance removed, which is sufficient evidence that the tool must by this means be much weakened; and the stronger tool (Fig. 81) is more substantial altogether, especially for deep cutting.

Figs. 82 to 93 represent moulding tools to be used in the eccentric or any of the revolving cutters. These tools were introduced by the author, and are most valuable for cutting deep and bold mouldings. When

employed in the eccentric cutter, they may be made to perform the part of a drill, by adjusting the right side, or dotted line, to the centre of the instrument, and the power vested in the eccentric cutter from the impetus gained by the revolution of the right-angle slide enables most beautiful work to be done by it, and finished in one cut, instead of having to use two or three tools to produce the same result.

Figs. 83, 85, 87, 89, 91, 93 show the same tools made as duplicates, and when these are used as drills the centre line is still on the right side, but the figure being made on the reverse side when used as a drill, the result obtained is a pyramid, the exact counterpart of the figure of the tool. These tools are also largely used for cutting mouldings, either in the horizontal, vertical, or universal cutters, and when the figure is required on both sides of any portion of the work, the tools being made in pairs, the mouldings are produced exactly alike. Placed in the socket (Fig. 5) used for holding the eccentric cutters in the goneostat, and held in the socket-handle (Fig. 60), they may be used as hand tools, or in the slide-rest as fixed tools, to produce their shapes on the work prior to cutting the same with the revolving instruments. These tools have been proved to be very valuable indeed for the purposes for which they are intended.

It is scarcely necessary to state that the eccentric

cutters are available for the various instruments, such as the eccentric cutter, the rose cutter, the epicycloidal cutter, the elliptical cutter, and by using the small saddle, Fig. 96, are held in the instruments which have mortise-holes of the larger size.

CHAPTER XVI.

THE VERTICAL CUTTER.

THERE are several instruments by which vertical cutting may be effected, either the universal cutter, the horizontal cutter, or that now under notice ; there are two or three ostensibly for the purpose, and as the frame, from its size, is more convenient, Fig. 94 is generally used for such work. The engraving is illustrative of the instrument ; the spindle revolves between two centres, one of which is fixed in the left side of the rectangular frame, while on the opposite side of the frame a centre-screw is arranged. The latter is adjustable, and fixed with a screw, the side of the frame being split so that it closes tightly round it. The left side, that in which the dead centre is fixed, is chamfered to an acute angle, so that the frame may be placed in closer contact with the work. It may here be mentioned that the inability to present this cutter-frame in close proximity to work upon which deep shoulders are attached, is one of its drawbacks. It has pulleys of different diameters, so that the tool may be set at various radii. The saddle (Fig. 96) is for the

purpose of employing the eccentric cutters, and (Fig. 96a) the spanner for removing the pulley. Fig. 95 represents another style of vertical cutter, which was invented by Dr. Stodart. This is a more convenient instrument in many ways, its chief advantage consisting in its ability

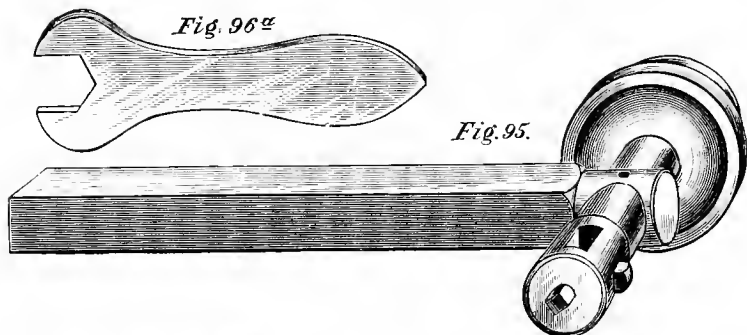
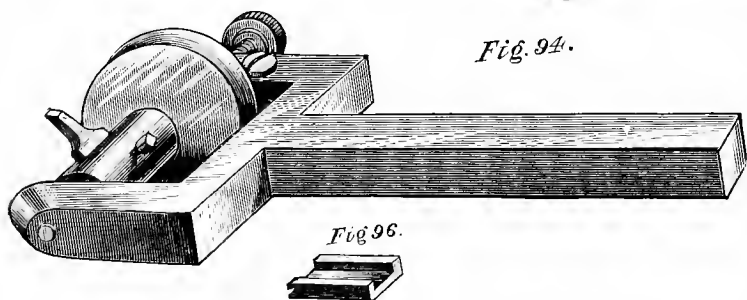
*Fig. 96a**Fig. 95.**Fig. 94.**Fig. 96.*

to approach the flange or shoulder of the work. The spindle, it will be seen, revolves in a steel collar, which is fixed in the end of the stem at a right angle to it. The mortise in which the tool is held is made near the end of the spindle, and the driving-pulley fixed to the

opposite extremity; by this means the cutter can be carried close to a shoulder with every facility. The tools illustrated by Figs. 109 to 117 are made to project over the extreme end of the spindle, and so the cutting edge has nothing to prevent its approach to the work.

It has been suggested that, made in this way, the spindle is likely to wear to a slight angle from the continuous pressure of the band, and ultimately to occasionally stick fast. This has been proved to be quite an erroneous idea if the instrument is correctly made, and it is considered by well-known amateurs to be the most convenient design of vertical cutter. In adjusting the instrument for use, there are two points to be considered—first, the radius at which the tool is extended from the centre of the spindle; secondly, the width of the tool to be employed, which should be of a definite size, so that the movement laterally may be more conveniently determined by a corresponding traverse of the main screw of the slide-rest in equal ratio, or as may be otherwise required, and denoted by the divisions on the micrometer. The penetration is governed entirely by the guide and stop-screw of the top slide, the bridle being always on, so that the slide is moved independently of the lever, which is now seldom used.

Mouldings of various patterns may be cut with a series of tools, or to a certain extent with one tool in

which the whole figure is contained ; but in most cases the separate tools are preferred. Those objects which are curved or conical may be ornamented with satisfactory result, without the aid of the curvilinear apparatus, but the greatest care must be exercised with regard to the depth of each series of cuts, taking care that the original outline is maintained throughout. Should the turner, however, be possessed of the curvilinear apparatus, much trouble will be saved and greater accuracy attained.

The cuts may be arranged in a number of different ways upon cylindrical or taper forms, some in contact, while in others an interval is left between each ; there is, in fact, no end to the variations to be produced.

The following simple examples, suitable for serviette-holders, will suffice to illustrate a few of the minor patterns to be cut, and at the same time explain the manipulation of the instrument for the production of this kind of work.

In the first place the rings are all turned out to the same size inside, in order that one chuck may do for all, thus saving a deal of time ; for this purpose a piece of well-seasoned boxwood is driven into a metal chuck, preferably of less diameter than the material. Chucking work of all kinds should always claim great attention from the amateur turner, as efficiency in this branch of turning renders the work very much more

easy and enjoyable, for there is nothing more annoying, as previously intimated, than to find the work has been gradually shifting on or in the chuck during its progress, or to discover that it is split through being driven too hard on to the chuck.

To hold rings similar to those under notice the following few hints may be serviceable. The chuck should be turned very slightly taper, and the ring fitted to it, then gently tapped on with the handle of a tool or a light mallet, and set quite true, which, if correctly fitted, will not be found a difficult matter. There are, as will be seen, several distinct applications of the cutter to the work, the continual rotating of the winch-handle causing the removal of uninterrupted segments of circles, the length of each being determined by the fluting stops.

Fig. 1, Plate 2, is a perfectly simple application of the instrument, and may be considered a primary example. The slide-rest is placed parallel to the lathe-bearers; the vertical cutter is then placed in the tool-box and adjusted to the exact height of the lathe-axis, and the tool extended to a radius $\frac{7}{10}$, a round-nosed tool being employed. The fluting stops are then set, one on each side, to arrest the traverse of the slide at the desired length. The necessary depth is ascertained by trial, and so adjusted that the terminal cut will bring up the pattern without reducing the diameter of the

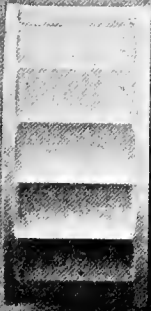

1

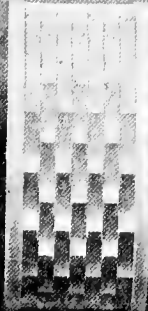

2

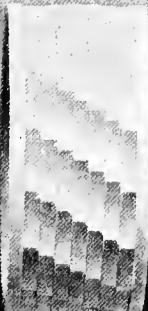

3

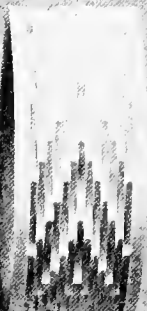

4

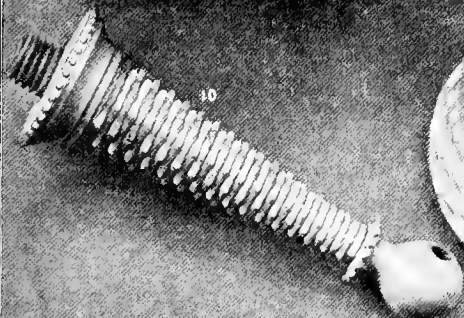

10



9



5

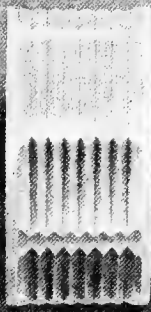

6



7

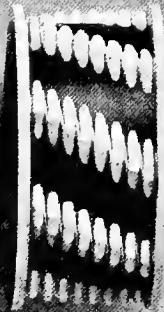

8

work. In this way the first and second cuts are made, and if a small space is left between them the tool must be advanced to cut deeper, and when once set, the stop-screw is fixed. The 96 circle was the division used, advancing six holes for each cut. The tool is moved slowly by the winch-handle laterally while it is revolved at a quick speed, and by this means a highly polished surface is obtained. All such work can only be left from the tool, and it is necessary to pay the greatest attention to its cutting edge, or no good work will result.

Fig. 2 having been chucked in the same manner, is then cut, as seen by the illustration, with a series of consecutive cuts, the slide-rest still parallel to the lathe-bed; a square-end tool, $\frac{1}{10}$ in. wide, replaces the round-nosed one previously employed, the 96 division being again used.

The tool is adjusted for the first cut by moving it laterally to the position required, and the figure at which the micrometer reads noted. The depth of cut is then ascertained by two trial cuts as before; the winch-handle is then removed from the screw in case its position should by any means be altered. The first series is then cut round at every sixth hole; the tool is then moved laterally exactly its own width, which being $\frac{10}{100}$ in. will require one turn of the main screw, the division-plate is moved forward three holes, and the

second circle cut at every six. By reference to Fig. 2 it will be seen that the termination of the second row of cuts is precisely in the centre of the first; for the third, return the index to zero, and again cut round at every six holes, each time moving the tool its own width, the same movements being repeated throughout the length required.

Fig. 3, it will be seen, differs again in effect, although cut with the same tool and division, also equal penetration, the only alteration required being in the movement of the dial-plate, which, instead of moving three holes forward and returned to zero, is moved only one hole, and then cut at every six as before; for example, the first circle cut at 96—6, 12, 18, 24, 30, 36, 42, and so on to the end. The second series begins at 7, 13, 19, 25, and 31. For the third, the starting-point will be 8, 14, 20, 26, 32, and thus the pattern is carried out its entire length, the tool being moved its own width for each circle; and it is in this way that the spiral effect is obtained. The twist or pitch of the same may be easily altered by varying the division.

Fig. 4 represents a further development of the manipulation of the instrument, showing that the pattern may be reversed, rendering a very considerable difference and elegance to the work. The settings for this figure differ from those already alluded to, in the following way: The radius of the tool is reduced $\frac{2}{10}$ in.,

a tool of just half the width—namely, $\frac{5}{100}$ in., is used in place of that of $\frac{10}{100}$, and each series of cuts carried round at every eighth hole of the 96 division, advancing two holes for each series, instead of one, as in Fig. 3. The tool is moved laterally its own width, and having repeated this seven times, the index is moved two holes in the reverse direction, and the first cut made of the return journey, the tool again moved half a turn for each cut, the division moved eight holes, and then proceed as in the first instance, with the exception that it is done the reverse way. This is also a very effective pattern for the interval between the lids and bottoms of boxes, and very many other subjects.

Fig. 5 is cut in the same manner as Fig. 3, a bead-tool being substituted for that with a square end. The 96 division is still used, arrested at every sixth hole, the tool moved its own width, $\frac{10}{100}$ in., and the division advanced two holes instead of one; it will be seen that a considerable difference is derived from the cuts being rendered the shape of the tool employed.

Fig. 6 is cut in still a different way. The tool (a round-nosed one) is set out to a radius of $\frac{9}{10}$, but having only eight consecutive segments cut, every twelfth hole of the 96 division was employed, each cut having a space intervening. The tool now has the radius reduced $\frac{2}{10}$, and the division moved forward six

holes, which brings the centre of the space between the previous cuts into position. These are then cut up sharp, the depth ascertained by trial as before.

The round-nosed tool is now replaced by a double angle one of 45° , the slide-rest is then set so that by seven revolutions of the main screw, a like number of consecutive cuts are produced. The cut is set in deep enough to bring the angle up sharp, the depth being again ascertained by two trial cuts. Having made the first cut on each segment, the tool is moved $\frac{1}{10}$ in., by one turn of the screw for the second, and then inserted all round again. This is repeated through the length required, in each of the eight segments, with the result seen in Fig. 6.

The majority of these examples are termed basket-work, and the variety is endless. Fig. 7 is another description of the same class, and it will be seen that the material is cut through, and afterwards filled in with black wood or other material. This is one of the most decorative of its kind, and the following is the correct way to proceed with it: The inside of the work should be turned out perfectly true and smooth, and then accurately fitted to a boxwood plug or chuck, and fixed with very thin glue; it must be so fitted that the ivory touches the wood all over, if not, when the tool passes through that part not adhering, the material will be likely to break and splinter, and spoil many

hours' work. In other respects the work is performed in precisely the same manner as when the figure is not cut through. The settings for Fig. 7 are, every sixth hole of the 96 division for the first sixteen cuts: move the tool laterally its own width, $\frac{5}{100}$ in., or one half turn of the main screw, move the division one hole, and cut round again at every sixth hole, these movements being carried out the entire length of the work.

Fig. 8, it will be observed, bears a very different appearance, although cut in a similiar way, the alterations being the substitution of a bead-tool $\frac{1\frac{2}{100}}$ in. wide in place of the square-ended one, and instead of sixteen cuts, only eight are made, leaving a wider interval between each; the radius of the tool is extended $\frac{2}{10}$ further from the centre. Such work can be lined with ivory and stained various colours, and by doing so very effective work is produced.

Fig. 9 brings us to the employment of the same instrument for face work, and for this it is very necessary to be able to reduce the radius of the tool as much as possible, but, from the construction of the vertical cutter (Fig. 94), it is not possible to obtain sufficient reduction for many patterns, from the fact of the driving-pulley projecting beyond the diameter of the spindle that holds the tool; the universal cutter (explained in a future chapter) will therefore be found to be the most useful tool for the purpose.

Fig. 10 shows the same pattern, cut on a taper pillar, the tool being exchanged for a narrow pointed bead-tool; the plain form is first turned, the slide-rest being set to the necessary angle; the vertical cutter is then adjusted to a short radius, six cuts are first made at the large end, the tool then moved exactly its own width, the dial-plate moved half the number of divisions, and the cut repeated. The pattern is then carried the entire length of the shaft, the first at 96 moving 16 holes, for the second series, the index moved 8 holes, and cut round at every 16 from that point. For the third return to 96, and so on alternately, the starting-points will be 96 and 8, by which the ends of each succeeding cut terminate in the centre of the segment preceding it. This is a most effective style of work, and may be carried out in a spiral form by employing the combined movements in the same way as for Fig. 3.

NECESSARY TOOLS FOR THE VERTICAL AND OTHER REVOLVING INSTRUMENTS.

By reference to Figs. 97 to 106, it will be seen that the tools required for these instruments are identical in form to those already described as used in connection with the slide-rest and eccentric cutter, but from the size of the stem, which is the same as the slide-rest tools, the cutting edge of each may be greatly increased; in

the instance of moulding tools, of which Figs. 107 and 108 are merely examples, the figure may be extended beyond the width of the stem.

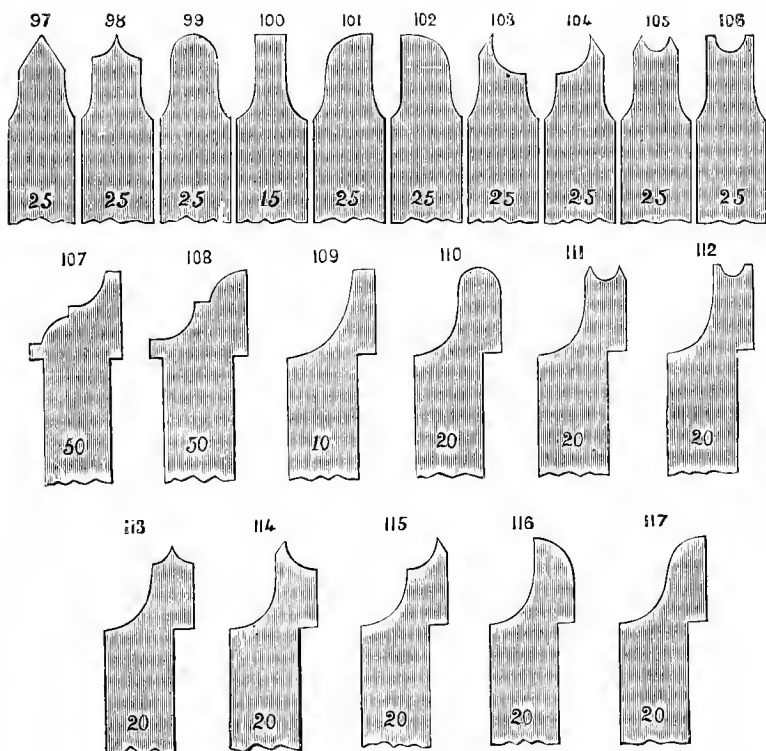

Figs. 109 to 117 represent vertical cutters, which do not appear to have been described in other works, but which are nevertheless a most valuable addition, and for some work indispensable. It will be seen that

their cutting edges are extended to one side of the stem, so that when used in the universal cutter there is nothing whatever between the shoulder of the work and the cutting edge of the tool ; therefore the pattern may be cut in close proximity to any projecting flange, and by such tools many subjects may be completed, from a decorative point of view, that would otherwise have been left plain from inability to approach that part.

It is necessary to have a few of the ordinary vertical cutters of intermediate lengths, about $1\frac{1}{2}$ in. These, however, are used generally in the universal or horizontal cutters, which will accommodate their length, and they are most essential to shaping work requiring large curves. The shapes of the various tools in this group being facsimiles of those previously referred to, it will not be necessary to repeat the details ; they vary in length from $\frac{7}{8}$ to $1\frac{1}{2}$ in.

CHAPTER XVII.

THE HORIZONTAL CUTTER.

THE horizontal cutter (Fig. 118) is made after the same manner as the vertical cutter, the rectangular frame being considerably larger, the centres are both adjustable for the purpose of setting the tool more accurately to the precise height of the axis of the mandrel, which is an important point with this, as in all other instruments.

The revolving spindle in this case stands in a vertical position while the tool revolves horizontally. To conduct the driving-band from the overhead motion to the pulley of the spindle, two guide-pulleys are fitted to a transverse spindle on the top of the frame, which has sufficient length on each side to admit of their self-adjustment to the diameter of the pulley used. The revolving spindle has an oblong mortise, the same size as the vertical cutter, and this is made in such a position that the tool is held precisely opposite the centre of the stem, which is the height of the axis of the mandrel. The tool is fixed by a square-headed screw.

This is found to be easier to manipulate than the screw-driver, as made in some instances, and is less dangerous; a slip with a screw-driver, while operating on a spindle running between centres, is very likely to occur, and will cause considerable damage to both fingers and work. The square head should be made to occupy as

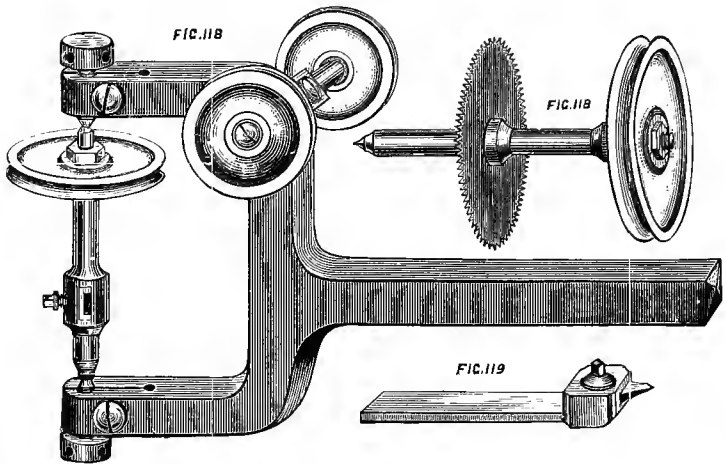

little space as possible, and will be found more convenient in every way. The instrument being made for work of a larger character, the screw-head will not come in contact with the work.

There is a second spindle fitted to hold circular cutters, which are used more generally for metal work, but are at times employed for purposes connected with ornamental turning. A thin circular saw, fitted to a

spindle, and figured also 118, is a most useful tool for dividing work into halves or segments. The saw is adjusted to the exact height of centre, and when revolving at a high speed may be passed along a cylinder, when it will divide accurately into as many parts as may be required. It may also be used to operate on the surface by shifting the slide-rest, and it was found extremely useful in dividing the rings which form the branches of the ivory candelabra, described in a subsequent chapter. There are many other purposes to which it can be applied.

The centre screws, having some length of adjustment, are used at times to set the tool above or below the centre, as may be required. This does away with the necessity for altering the height of the slide-rest, and answers the same purpose, unless for any special reason a greater elevation or depression is required than the centre screws will allow. The various spindles each receive three different-sized driving-pulleys, the largest just passing the back of the frame, and is only used when considerable power is required, necessitated by using one of the slide-rest tools for a long sweeping curve, the smallest being used when it is necessary to approach nearer to the work.

Fig. 119 is a socket which holds both the vertical and eccentric cutters, which are very often used in this instrument.

From experience, the author finds that few amateurs know really the extent to which this, as well as many other instruments, may be applied. The work may be approximately roughed into shape by hand, but unless a deal of time is spent, the exact curve that would be cut by the tool, when extended to a certain radius, is not arrived at; but if the tool is first adjusted, and then placed into cut by the slide-rest screw, it can be revolved at a high speed, while the work is slowly rotated by hand. For such work it is not necessary to use the segment apparatus; shaped in this way, it will be clearly seen that the desired curve is at once cut.

It is always better to use the main screw of the slide-rest for inserting the cut, when it is set parallel with the bed, although in some instances it is perhaps more convenient to turn the slide-rest round to face the work, and decide the depth by the guide and stop-screw of the top slide. When the slide-rest is set parallel to the lathe-bed, the left side fluting-stop is fixed, to arrest the tool at the correct depth for each successive cut, and with the slide-rest set in this way the work is more conveniently executed.

A few specimens of the work thus executed are illustrated on Plate 3. Fig. 1 shows a piece taken from the end of a column; it was cut with a pointed bead-tool (Fig. 105), set precisely to the centre of the lathe axis. This is a point which must claim the

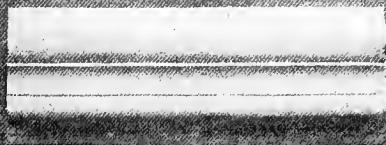
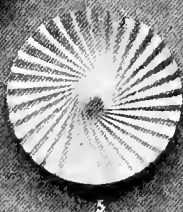
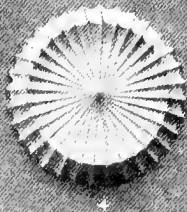
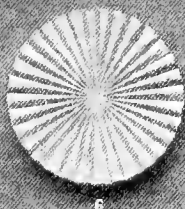

2

2

utmost attention, as a defect in this adjustment entirely alters the character of the work. There are twelve distinct cuts, the projection between the reeds being left by the angle on the point of the tool; it is cut at every eighth hole of the 96 division. When the tool has received sufficient penetration, it is traversed throughout the length required by the main screw, and if desirable can be arrested at any point by the application of the fluting-stop. Having made the twelve cuts, the index is moved four holes; this will bring the projection left between the reeds to the centre. The bead-tool is now changed, and replaced by one with a square end, $\frac{1}{100}$ wide, set just deep enough to remove the sharp point, and reduce the top below the diameter of the reed.

Fig. 2 illustrates another variety of forms to which a cylinder may be reduced; the section (Fig. 2) cut from the column shows the distinct shape of the figure; this was cut from the cylinder $\frac{1}{10}$ in. diameter, the deep concave recess being cut with a round-nosed tool $\frac{1}{100}$ in. wide, and traversed by the main screw as before. The six cuts being made, the tool is removed and replaced by a bead- or reeding-tool (Fig. 106), having a square or astragal end in place of the pointed one used for Fig. 1. This is a figure in which attention must be given to the depth of each cut, in order that due proportion is attained. Here again any length

may be cut, and the tool arrested at intermediate portions of it. In cutting columns of this particular character, the radius of the tool should be as short as possible, although any reduction or extension of the same does not in any way alter the shape of the figure, unless the cut is arrested at any point within the cylinder.

Fig. 3 introduces an entirely different application of the instrument, and it will be seen that the pattern is carried entirely over the shape first turned. In producing this, the material is first roughly shaped by hand. The cutter is then placed in the slide-rest, which is set parallel to the lathe-bed; the tool (a round-nosed one), being adjusted to a radius that will cut the curve as nearly as possible to the shape turned, is then set in, and the work slowly rotated by the hand on the pulley. By this proceeding the exact shape is again produced; the round-nosed tool is now removed, and a double angle one of 50° substituted, the following being the safest way of setting it to the same radius as the one previously used: The slide should be left in contact with the fluting-stop; the tool may then be removed from the spindle, and the one next to be used placed in it, and extended to touch the surface of the work, and then fixed by the binding-screw. The fluting-stop is then released, and the depth of cut ascertained by two trial cuts being made sufficiently deep to bring

the angles up sharp. This decided, the fluting-stop is again clamped tightly to the slide, and the succeeding cuts made. The top slide, once set to the depth, is not moved, the cut being made from right to left by the traverse of the main slide until arrested by the fluting-stop, which will render all the cuts exactly alike. The slide is traversed the reverse way to withdraw the tool out of cut while the dial-plate is altered. It may be removed from contact with the work by the top slide, but it is preferable to release it by the main screw. There are 32 cuts, and when all have been thus made upon the curve, the slide-rest is moved towards the margin of the work in order that the edge of it may be cut. To effect this the tool may be re-set to the correct depth of penetration by trial cuts, and is then passed over the width of the edge, the same division, of course, being employed. Should the tool require to be sharpened, it must be remembered that the greatest accuracy is required when replacing it in its original position, and the readiest way is to place the tool to the extreme depth of cut, leaving the slide in contact with the fluting-stop, and then remove it from the spindle; it may then be sharpened and returned to the original depth, and again tightened in the spindle, by which the depth and radius are both maintained.

Fig. 4, it will be observed, is cut with a round-nosed tool in place of the double-angle one, the outer

edge being also curved instead of square; the cuts, being narrower as they near the centre in consequence of the diminishing diameter, give great and varied effect to the work. Again, there are 32 consecutive cuts, the bare form being cut in the first place in the same way as Fig. 1; in fact, all corresponding figures require the same treatment. The slide-rest is then brought forward, and the radius of the tool reduced and adjusted to cut the second curve, as seen in the illustration.

Fig. 5 demonstrates the variation of effect to be obtained by raising the tool above the centre, which, in this case, was elevated to $\frac{2}{10}$ in. above the axis of the mandrel, and it will be seen that a double-angle tool was employed; and the simple changing of the tool, employing more or less elevation and increased depth of cut, all tend to alter the result obtained. Very elegant designs emanate from first cutting with the tool elevated, say, $\frac{2}{10}$ in. above the centre, and again with it depressed below the axis to the same amount.

Fig. 6, although a simple example, is illustrative of the accuracy required, and the means employed to obtain the precise height of the centre, which is so important in all figures.

To obtain the precision necessary, the slide-rest is set transversely across the lathe-bearer, and a very delicate cut made on one side of the centre, the

division-plate then moved one half-turn, and the tool carried across to the other side ; if the point of the tool does not agree accurately with the line, the height of the centre must be altered until it does.

It will be seen that the face of the pattern is flat, although it is cut with the tool revolving at a radius of $\frac{6}{10}$, but the fact of passing the tool entirely across the face of the work, and exactly at the centre, leaves the points accurately placed in that direction. This particular pattern is one that fully establishes the necessity of extreme accuracy in the adjustment of the tool in this particular respect. These few examples will suffice to show how the horizontal cutter is employed for work of this class.

CHAPTER XVIII.

A BASKET-WORK CASKET.

IN introducing an increased number of illustrations of decorative specimens, I am anxious to take advantage of the many suggestions which have been so kindly put forward by the numerous readers of the first edition of this work. And in so doing, my desire is to meet the requirements not only of those amateurs who are already well advanced in the art of turning, but also those for whom the more rudimentary details are not only desirable, but necessary.

In the first of the new series of designs, I deal with a subject which is at once elegant and easy of accomplishment, and the interest therein is considerably increased by the simple fact that it requires no additions of costly apparatus, nor, indeed, any further outlay in order to reproduce it.

On reference to the design in Fig. 120, it will be seen to be of elliptical form, and, when the dimensions are considered, it will be found to be of a bold and massive character.

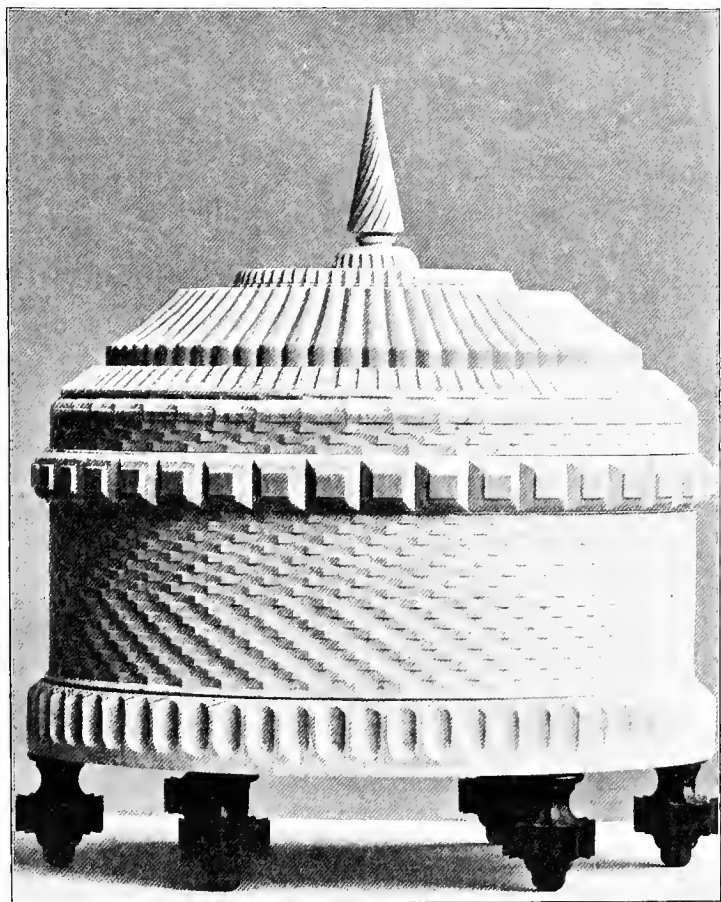

Fig. 120.

The first item for consideration will be to select a suitable ivory hollow, the size of which should be as nearly as possible $7'' \times 5\frac{3}{4}'' \times 3\frac{1}{2}''$, and I may as well say at once that some difficulty will be experienced in this, as ivory is not readily found of such proportions.

It is not imperative, however, that these dimensions should be strictly adhered to, and if the ivory cannot be found to exactly correspond with these figures, then, of course, the nearest size that can be obtained should be selected. The various steps necessary to the reproduction of the design will be identical in all respects to that of the full size, the only difference being, that on completion there will be found variations in the several cuts and serrations, arising naturally from the decreased size of the material. I say decreased, as it is very unlikely that ivory of larger dimensions will be found.

It is important to carefully study the manner of holding such a hollow. Even if a universal chuck is at hand, it is not desirable to employ it, as the grip of the jaws, which will be required to hold it sufficiently firm, is likely to so compress the part held, that when released the inside form will become irregular and distorted.

The safest way will be to proceed as follows:—Secure a sound, well-seasoned piece of mahogany, large enough to cover the outer extremity of the material, and then set the ellipse chuck as nearly as possible to

turn a corresponding form to the interior. Face one end of the ivory, and then, with the inside fitting as a guide, carefully glue the ivory to the wood, and place under a weight until quite dry. Thus held, the inside can be readily turned out perfectly clean and true in all respects, and when finished can be released from the chuck, after the application of warm water to soften the glue.

It will be found that the inside has, by this means, retained that truth and accuracy which is so essential to our further progress, and will thus be a safeguard to precision throughout. But before removal of the ivory, it should have been highly polished, as described in Chapter VIII.

The next proceeding will be to chuck the ivory by the inside on a corresponding form, and if a piece of boxwood can be found large enough, that will be the most suitable material to use, but failing this, the next best will be a well-seasoned beech or mahogany chuck.

The sliding-ring of the ellipse chuck being extended to precisely the same setting as for the inside, the wood is carefully turned to exactly fit the inside of the ivory; and, as it will be recognized that there is a great deal of work to be executed on this part, it is a good plan, in fact, I may say, absolutely necessary, to glue the ivory to it, and thus prevent the possibility of its moving in the least degree.

The slide-rest must be set parallel to the lathe-bearer, and the exterior turned to the shape seen in the illustration, in the plain form first. Those parts that will not be ultimately excavated must be highly polished, as previously explained.

When the outer surface is so far prepared, we may proceed to decorate this part, commencing with the lower rim.

Adjust the ellipse chuck to stand in a vertical position, or at right angles to the lathe-bearer (this is certified by the aid of a back-square placed on the bed), and the compensating index made to enter the division when the chuck is adjusted.

The slide-rest being parallel, the drill-spindle is the first instrument to employ, and in this a large round-nose drill $\frac{30}{100}$ wide. Place one fluting-stop at the left-hand side to determine the horizontal traverse of the drill. It will be seen that the cut is carried out at the upper termination of the rim.

In this there are sixty consecutive flutes, and it will be scarcely necessary to mention that any circle may be used that will equally divide into this number.

Immediately above this rim will be observed a small plain continuous bead, and when the fixed tool is supplemented in place of the drill, great care must be exercised in its adjustment to the precise centre.

The basket-work commences above this bead (most

turners will recognize the style of work by this name), and around the body are forty-eight consecutive cuts, to make which the best instrument to use will be a universal cutter adjusted to cut vertically. But should it so happen that this instrument is not comprised in the outfit at hand, then either of the cutter-frames in Figs. 94 or 95 may be used.

In the tool receptacle place a cutter exactly $\frac{1}{10}$ in. wide, and it will be seen that the cutter performs its work in the vertical plane, although the instrument is set to revolve horizontally.

Adjust the cutter to commence the work close to the continuous bead, when the chuck is again set vertically, then set the cutter to a radius of $\frac{5}{8}$ in., and commence the work.

The penetration must now be decided by two trial cuts. Cut first of all with the index at zero in the 144 circle, move the dial-plate through three holes and cut again, cutting each of these two equally until the surface is just reached, when the terminal point will be quite sharp.

Having determined this primary adjustment, the first series may be completed, the plate being moved three holes for each cut. Before attempting to move the tool laterally, see that the index on the main screw of the slide-rest is accurately set to zero.

Having now the necessary settings complete, and

cut once round, the tool is moved by one turn of the main screw of the slide-rest precisely its own width. Move the dial-plate one hole forward, and commence the second line of cuts. After the first cut, move three holes for each succeeding one. Repeat these movements until nine consecutive series have been made, and this will bring us to the centre of the space between the two rims, on the body of the casket. Proceed to cut the second half in exactly the same way, but moving the dial-plate in the reverse direction.

It will be seen that the various cuts result in a spiral formation, caused by the forward movement of one division of the dial-plate only for each cut; whereas, had the several cuts been made with the index moved but one half the distance, the points would have assumed throughout a vertical direction.

Passing now to the upper rim on the casket (which in the original is exactly $\frac{1}{2}$ in. wide), this is first shaped on each side with right and left moulding tools fixed alternately in the slide-rest. When this is done, let both be highly polished. Then let the universal cutter in the slide-rest revolve horizontally, and place in it a short cutter with a corresponding profile. In this are forty consecutive cuts or serrations (using the 120 circle and advancing three holes for each one). To satisfactorily complete these, considerable care is

required in adjusting the penetration, or depth, in order that the corners may mitre up correctly, and it is also necessary that care be exercised when passing the cutter through laterally, in order to minimize the risk of the corners chipping, and also to secure as smooth a surface as possible. The body of the casket may now be regarded as complete.

The lid or cover is the next part. This rises above the rim for the distance of three cuts, and being cut in the same way, and with the same tools, is, of course, of the same pattern.

Above this is a moulded rim, formed with a quarter hollow cutter; forty-eight separate cuts being made. From the top of the moulded edge a chamfered edge is turned, perfectly flat, but afterwards fluted with a round-nosed drill, employing the 96 circle of division, cutting at every division, and resulting in an equal number of flutes. So far, this completes the cover.

The following part, being a separate piece of ivory, must be carefully fitted, and must lie flat on the lower part, on to which it is placed. The short vertical edge and concave curve are first formed by plain turning, and the former is then cut to a series of short reeds. Here, again, it would be desirable to use the universal cutter, supplemented by a double quarter hollow tool (Fig. 73) adjusted in the holder, and revolving as

before in the horizontal position. The 120 circle of division should be used, and moved to alternate holes for each cut, thus leaving a total of sixty reeds. The radius, or distance to which the tool is extended, must depend very much upon the curvature of this part. The gradual diminution in the width of the reeds towards the top is caused by the equal decrease in the diameter of the two axes of the ellipse, and forms a graceful termination.

On the top of this, another flat piece of ivory is placed, serrated round its edge with a quarter hollow drill, and having, also, sixty separate cuts. On the top of this, an eccentric pattern is cut on the space between the two minor axes. This cannot be shown on the plate, but it affords an excellent finish to what would otherwise be simply a flat surface.

The finial, it will be seen, terminates in a long cone with a moulded base, and it will be seen that it is cut to a spiral twist of extended length, to secure which wheels are employed which will give one turn in 7 in., and in all sixteen cuts are made.

If it should so happen that the spiral apparatus is not available, the flutes on this portion may be cut straight, or even omitted entirely, and in the alternative, the cone very highly polished.

The casket may now be regarded as finished, and the next step will be to mount it. It will be observed

that the casket is made to stand on six black wood feet, which serve to make it very much more attractive, and, whilst rendering it more finished in appearance, adds to its effect in every way. In order to accomplish this, the body of the box must be chucked by the upper part, and six holes drilled in the base. The black wood feet are then fitted. These feet may either be of the design illustrated, or any other form which may appeal to the operator. As shown in the illustration, the feet are reeded with a double quarter hollow tool at the largest part, and the hollow is cut with a large round-nose drill, using the same divisions as before.

The lower curve is similarly treated with an ogee moulding drill, the terminal being a plain ball.

I think these details will enable my readers to execute the work in this casket with comparative ease. It is not in any way a difficult subject to undertake, and, if the spiral twist at the finial is dispensed with, does not require any elaborate or special apparatus of a costly character.

One final point must be mentioned, namely, the manner of forming the bottom of the box. It will be remembered that, the casket being made from a hollow, a bottom had to be fitted. In my case I did not cut a large piece of ivory, which would have involved waste, but used a piece of Spanish mahogany. This was well fitted to a rebate turned in the lower rim, and then

turned off flush with the surface, and I so arranged the holes that receive the feet, that the flange of the latter secured the bottom in its place. The only reason for employing mahogany was that of economy; ivory can, of course, be used if preferred.

CHAPTER XIX.

ELECTROTYPING.

SINCE my previous remarks with regard to the above subject, the art of reproducing examples of ornamental turning in relieve has been largely developed, and I am sure, therefore, that some further information in reference to this branch will be duly appreciated, as well as prove to be of considerable service.

We may, I think, safely pass over those patterns which mainly consist of fine line tracery, although many of these may be cut to such a depth that by enlarging the various adjustments and settings of the several instruments employed, some very beautiful specimens—the reverse of what is actually cut in the lathe—may be produced.

Let me pause, however, to pay tribute to the skill and genius of the Rev. A. B. Cotton, and to whose enthusiasm is largely due the development of this interesting study, which forms such a valuable addition to the possibilities of the scientific amateur.

Electrotyping is a subject in itself, but this fact in

no way deters its votaries from reproducing their own work. And with such evidence before us of its possibilities, there is little room for wonder that so many ornamental turners are now using it for decorative purposes.

The impossibility of producing this particular style of work in the lathe may, perhaps, account for the charm inspired by the process, and the admiration which it evokes.

The greater beauty of relieve work, as compared to intaglio (or sunken work), is self apparent, and I hope that the various examples which it is my intention to refer to and illustrate throughout this work will be the means of creating still further interest in, and lead to the increased development of, this elegant and valuable form of decoration.

Such patterns as those cut with the eccentric cutter may be (if carried to a considerable depth) made to show very beautiful effects. The bolder, or deeper work, however, is that which calls most for our consideration. Although the eccentric cutter is of great value, yet we get a more varied selection of designs from such instruments as the universal cutter, the vertical cutter, and the horizontal cutter, any one of which will afford means of cutting the work to a more suitable depth; and the numerous curves emanating from the sweep of the tool, when adjusted to the

different radii, and this particular style of work, present opportunities for a greater play of light and shade on the reproduction than the patterns first alluded to.

The drilling instrument, also, is an excellent medium for placing beads in a large variety of ways for the purpose of forming part of a device necessitating such a formation at any particular spot, which could not otherwise be obtained.

The segment cutter is also a valuable instrument in the reproduction of suitable subjects. This tool, designed by myself, is capable of effecting a type of work highly suitable for electrotyping, as its cutting depth is not limited, and the beauty of the effect is greatly enhanced when such work is subjected to the process now under consideration.

The segment cutter will be fully described and illustrated in Volume II., and the examples there given will show clearly its effect when used for the ordinary style of ornamental turning, as well as when treated with the electrotype process.

So far, then, we may consider that we have such instruments as may be regarded of simple form already detailed; and when we come to the complex examples we shall find that the more extensive apparatus is equally applicable. These will consist of the rose cutter, epicycloidal cutter, ellipse cutter, segment apparatus, spiral apparatus, geometric chuck, ellipse

and eccentric chucks, etc., all of which we may requisition into our service.

It is perhaps the least complicated examples that afford the most elegant results. I am, however, safe in saying that the variation to be obtained is practically unlimited, but it will, of course, greatly depend upon the taste and ability of the operator as to what subjects he produces.

The simplest and, to my mind, the best way of obtaining the original block is to employ type metal as the foundation upon which to commence operations. If this be used, the pattern may be cut cleanly, and will not (as is the case when wood is used) require further preparation by the application of conducting material. Type metal also gives a sharper impression, which will be at once recognized as a most important feature in this class of work.

One great caution must be impressed, in this place, upon the reader. Should any error be made, it will come out with equal clearness in the electro. Care should therefore be taken to avoid error; and should any exist, it will be well not to waste time by submitting the block to the electrotyping process, for it is certain to result in failure and disappointment.

The best way to secure the metal discs will be to make a boxwood model. When doing this, select a spring chuck of suitable diameter, making the wooden

model to just fit it. A slight increase of size should be allowed for, as the metal will shrink in cooling. Cast a reserve stock and let them be about $\frac{3}{8}$ in. thick. This will allow enough for turning the surface clean, and depth enough for most examples. Time is saved by having this reserve stock prepared beforehand.

The keenness of the cutting edge of the tools will call for a few remarks. Great attention must, it is needless to say, be given to this, or the results cannot be satisfactory. It will be apparent, that where the tool crosses or merges into a cut previously made, it must cut with perfect cleanness, avoiding the slightest fraying of the edges. This, of course, is not difficult of performance, but it must be borne in mind, and the operation performed with due care and attention, as when properly executed the mould (for such it is in reality) will be perfectly free to receive the deposit when complete.

The principal object of making the discs fit the spring chuck is, that it affords a ready means of holding them securely, and when it is desired to make several examples of varying patterns, it is necessary to be able to readily release the grip of the chuck, in order to extract the one disc and replace it by another.

In Plate 3*a* will be found illustrated a series of examples, showing clearly how gracefully the patterns stand out in relief from the flat surface.

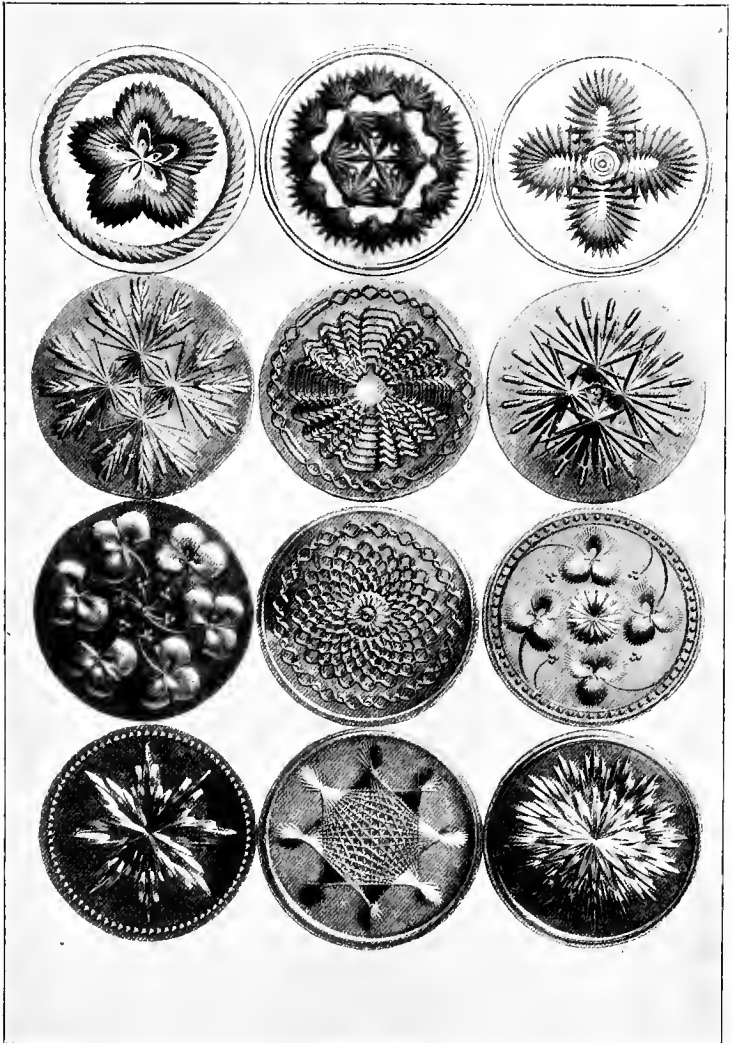

PLATE 3a.

Such work can be further treated in many ways. Still greater beauty, too, may be gained by depositing gold or silver upon the figure, which will then contrast wonderfully with a copper base, or otherwise.

I must also mention one very important point, viz. every possible care must be taken not to touch by hand the surface of the disc upon which the specimen is cut, as any such incautious handling will assuredly detract from the ultimate excellence of the results.

In the next volume this subject will receive further treatment, and more minute details will be given.

END OF VOL. I.

*PARTICULARS OF MR.
GUILBERT PITMAN'S
LATEST TECHNICAL
PUBLICATIONS WILL
BE FOUND OVERLEAF.*

BOTTONE'S AMATEUR ELECTRICIAN'S WORKSHOP. BOOK I.

Illustrated by 30 carefully prepared diagrams.

Cloth, 1/6 net; Post free, 1/8.

A Handbook of Practical Instruction in the making of Electrical Models and Appliances.

CONTENTS.

How to Make an Electro-Motor—The Making-up of Lalande-Chaperon and Chromic Acid Batteries—The Construction of a One-Inch Ruhmkorff Spark Coil—How to Make a Wireless Telegraph—How to Use a Wireless Telegraph—Sparking Coils for Motors: How to Make and Repair.

WHAT THE PRESS SAYS:

"Well worthy of a place in the library of the amateur."—*Westminster Gazette*.

"Gives the minutest directions as to the way to set about making an Electric Motor, Wireless Telegraph, etc., etc."—*Daily Graphic*.

"Capital; . . . quite up to the author's high standard."—*Literary World*.

"A wonderful amount of practical information."—*Electricity*.

"Will be found most useful."—*Daily News*.

"Valuable advice."—*Liverpool Mercury*.

"Details for making a Wireless Telegraph are clearly set forth."—*Ironmonger*.

"The instructions have the commanding merit of practicability."—*Mechanical World*.

"A practical little illustrated book."—*The Times*.

"Practical, smart, well illustrated, and clearly written."—*Scotsman*.

"Sure to be welcomed."—*Morning Post*.

"Noteworthy for the simplicity and clearness of its guidance."—*Standard*.

"Illustrated and practical."—*St. James's Gazette*.

"Should be a big demand for it."—*Birmingham Gazette*.

"The instructions are such that any novice could, with reasonable care, make the various items of apparatus described."—*Model Engineer*.

GUILBERT PITMAN, 13, Cecil Court, St. Martin's Lane, W.C.

JUST PUBLISHED.

PRACTICAL KITES AND AËROPLANES :

How to Make and Work Them.

Illustrated by Forty-three Carefully Prepared Diagrams.

Cloth, 1/6 net ; Post free, 1/8.

By **FREDERICK WALKER, C.E.**

Fellow of the Society of Patent Agents, Associate Member of the
Aëronautic Institute.

A Practical Work on the Construction and Use of Kites and Aëroplanes, with special consideration of the best mode of constructing kites for ascertaining the state of the upper atmosphere, photographing, wireless and luminous signalling, and, for those possessing sufficient confidence, aërial flight or aërial traction.

GUILBERT PITMAN, 13, Cecil Court, St. Martin's Lane, W.C.

LUKIN'S

POSSIBILITIES OF SMALL LATHES.

A thoroughly practical and up-to-date treatise
upon modern Lathes of small dimensions.

Profusely Illustrated. Cloth, 1/6 net; Post free, 1/8.

SYNOPSIS OF CONTENTS.

The Cheap £10 Lathe; Examples of a few Simple Articles; Designing; Home-made Tools; Ovals or Ellipses for Small Frames; Spiral Work; Square and Triangular Pedestals; Swinging or Balanced Overhead; Details and Further Particulars of Overhead; Cone Plate or Boring Collar; Pipe Chucks; Screw Chasing; Dumbleton's Apparatus; Ornamental Drilling; Metal Work; Chucks; Home-made Chucks and Drills; New Forms of Home-made Overhead; Principle of Cutting-Tools; Cutter-Bars; Gauges, Squares, and other Measuring Instruments; Simple Lessons in Turning.

PRESS OPINIONS.

"There must be many amateur users of small lathes to whom this little book will bring some pleasant surprises."—*Manchester Guardian*.

"Well-written, useful, and intensely interesting."—*Midland Herald*.

"Contains plenty of practical hints."—*American Machinist*.

"Mr. Lukin has a thorough understanding of his subject, and is happy in conveying his knowledge to others."—*Sheffield Daily Independent*.

"This is a handy little book of absorbing interest to the amateur mechanic. Valuable hints are given regarding ornamental turning in wood and metals, on drills and drilling, and the making of tools. It is a most useful book."—*Newcastle Daily Leader*.

"The subject is very attractively treated, and forms a most interesting revelation of the astonishing capabilities of a simple lathe. The book, moreover, is not marred by too technical descriptions, and is illustrated by nearly 100 pictures."—*Blackburn Telegraph*.

"The author is a well-known amateur mechanic, and his instructions are always thoroughly practical. The book is an excellent one, and will appeal to many of our readers."—*Scientific American*.

"Those of our members who incline to mechanical pursuits will be interested in this little book, which that enterprising publisher, Mr. Guilbert Pitman, has just issued. He refutes the idea that small lathes are useless toys, and gives many examples of work which may be done by a small machine."—*People's Journal (Dundee)*.

GUILBERT PITMAN, 13, Cecil Court, St. Martin's Lane, W.C.

BOTTONE'S IGNITION DEVICES

FOR GAS AND PETROL MOTORS.

WITH

A Chapter treating specially of
Structural Details, Choice, and Management
of Automobiles.

FULLY ILLUSTRATED.

Cloth, 2/6 net ; Post free, 2/8.

COMMENDATIONS FROM WELL-KNOWN PAPERS:

"This little handbook will be found invaluable to all amateur electricians and automobilists interested in spark coils and their workings, as well as in the other parts of an electric ignition system. The Author is a practical man of experience. One of the most interesting descriptions in the book is that of a combination jump spark coil and dynamo of his own invention. Instructions are given for making both primary and secondary spark coils. The theory of their working is also clearly explained. An introductory chapter on the automobile is of considerable interest."—*Scientific American*.

"Mr. S. R. Bottone's little volume on 'Ignition Devices for Gas and Petrol Motors' will be found very interesting to the amateur who is intelligent enough to wish to know something about the engine which drives his launch, his motor-car, or his bicycle. The preliminary section is devoted to a useful disquisition on the choice and management of automobiles, with well-arranged information as to their structural details. This chapter is alone worth the half-crown demanded for this book."—*Westminster Gazette*.

"Of such a character as to make the work almost indispensable."—*Manchester Courier*.

"Another book that should be added to the library."—*Review of Reviews*.

GUILBERT PITMAN, 13, Cecil Court, St. Martin's Lane, W.C.

TENTH THOUSAND.

SYSTEMATIC MEMORY ;

or, How to Make a Bad Memory Good, and a
Good Memory Better.

By T. MACLAREN.

ENLARGED AND IMPROVED EDITION.

Complaints are continually heard about bad memories. Some have the misfortune of having been born with "shocking bad" memories ; while others have, in their early years, been gifted with wonderfully good memories, but, by some mysterious process, have gradually lost the power of retaining even the most recent facts. Some, again, have the rare faculty of at once, and without the slightest difficulty, committing to memory everything they please, but, unfortunately, in a very few days all is entirely forgotten ; others, on the contrary, have very great difficulty in fixing anything in their minds ; but when once a thing is fixed, it is fixed for ever. The truth is, that most persons do not know how to employ their memories. The faculty may be tolerably good, but the power of application is too frequently wanting. The system set forth in this remarkable work is intended to make bad memories good, and good memories better.

Parents will do well to encourage their children to learn this science, which is indisputably one of the highest practical value.

Students about to go up for examination will find the system of peculiar assistance to them.

Price 1/- (net) Cloth.

GUILBERT PITMAN, 13, Cecil Court, St. Martin's Lane, W.C.

ENGINEERING WORLD

And Amateur Carpenter and Electrician.

2d. Monthly.

Principal Contents :

No. 1.

Lathe Work for Young Engineers.
(Continued in subsequent Numbers.)
Practical Electrical Engineering.
(Continued in subsequent Numbers.)
All about Primary Batteries.
(Continued in Nos. 2 and 3.)
A Design for an Artistic Wash-stand. Etc.

No. 2.

Shelves, and How to Fix them.
Home-made Device for Decorating Glass.
How to construct a Model Railway Track.
Locking Gate by Electricity. Etc.

No. 3.

How to Make a Small Water-Motor.
A Dwarf Bookcase and its Construction.
How to Make a Dynamo.
Proportions for 15-kilowatt Dynamo. Etc.

No. 4.

A Sideboard of Simple Construction.
How to Cure a Draughty Window.
How to Make a Wimshurst Electrical Machine.
(Continued in Nos. 5 and 6.)
How to Find a Fault on Telephonic Apparatus.
Reversing Gear for Electric Motor. Etc.

No. 5.

A New Soot-Proof Plug for Gasoline Motors.
An Inexpensive Overmantel for the Dining-Room.
How to Build an Electric Despatch Boat.
(Continued in Nos. 7, 9, and 11.)
Speed of Pulleys. Etc.

No. 6.

A Model Hopper-Bottom Railway Wagon.
(Continued in Nos. 7, 9, and 11.)
Practical Kites and Aëroplanes: How to Make and Work Them.
(Continued in Nos. 8, 9, 10, and 12.)
Electric Trams.
Proportions for a 12-inch Spark Coil. Etc.

No. 7.

Changes in Motor Windings for different Voltages.
How to Make a Cribbage-Board.
How to Make a Settle or Hall-Seat.
Self-Closing Coal Cabinet. Etc.

No. 8.

Three Simple Electro-magnetic Experiments.
How to Make a Magazine Camera.
(Continued in No. 9.)
Launches, Electric or Steam.
Screen for Fireplace. Etc.

Of all Booksellers and Newsagents, or

GUILBERT PITMAN, 13, Cecil Court, St. Martin's Lane, W.C.

THE

Shorthand World

THE LEADING SHORTHAND MAGAZINE,
Edited by GUILBERT PITMAN

(Formerly manager to SIR ISAAC PITMAN, LTD.).

32 pages. MONTHLY. 4d.

**For Faultless Outlines, Symmetry of Form,
Abundance of Matter, Guidance and Entertainment,
it is without parallel.**

The artistic beauty of the flowing shorthand characters—clear, bold, and legible, and divided into three grades, Easy, Medium, and Advanced—at once excites attention and admiration.

The shorthand matter for the student, contributed by writers of reputation and experience, is full of suggestive and helpful interpretation, while the lighter literature is selected with taste and judgment.

In short, nothing is neglected to maintain the already high standard of usefulness alike for the beginner and the expert.

“Letters that Bring Business,” written in the brief reporting style of shorthand, counted for dictation practice, forms a valuable means for attaining a high speed of writing. The SHORTHAND WORLD grants its Certificates of Competence in Shorthand and Typewriting free of charge.

*A Specimen Copy will be sent, post free, for 4d., from the
Publisher,*

GUILBERT PITMAN, 13, Cecil Court, St. Martin's Lane, W.C.

SINCE 1887,

KENSINGTON COLLEGE

Has held its unique and unbroken
record of having provided a

Satisfactory Appointment for every Student

OF THE

CHAMBER OF COMMERCE CITY COURSE,
AND THE SECRETARIAL TRAINING COURSE.

*Address:—The Secretary, Kensington College,
143, Queen's Road, Hyde Park, W.*

