

DOCUMENT RESUME

ED 134 735

CE 009 501

TITLE Surface Grinder Operator. Instructor's Guide. Part of Single-Tool Skills Program. Machine Industries Occupations.

INSTITUTION New York State Education Dept., Albany. Bureau of Continuing Education Curriculum Development.; New York State Education Dept., Albany. Bureau of Secondary Curriculum Development.

PUB DATE 73

NOTE 139p.; For related documents see CE 009 500

EDRS PRICE MF-\$0.83 HC-\$7.35 Plus Postage.

DESCRIPTORS Adult Education; *Curriculum; Curriculum Guides; Hand Tools; *Industrial Education; Instructional Materials; Job Skills; *Machine Tool Operators; *Machine Tools; Metal Working Occupations; Post Secondary Education; Secondary Education; Shop Curriculum; Skill Development; Student Projects; Teaching Guides; Vocational Education

IDENTIFIERS *Surface Grinder Operators

ABSTRACT

This course, the second one to be published in what is expected to be a series of instructor's guides in the Single-Tool Skills Program, is expected to help meet the need for trained operators in metalworking and is designed for use in the adult education programs of school districts, in Manpower Development and Training Programs, and in secondary schools. The general objective of the course is to train men, in a comparatively short time, to be placed as surface grinder operators. The guide consists of an (1) Introduction, (2) General Job Content, (3) Job Sheets for Shop Projects, and (4) Drawings for Shop Projects. The General Job Content section lists the content outline in the left column and teaching points and techniques in the right column. The 17 shop projects are Scriber, Drill Stand, Arbor Press, Surface Gage, Tool Bit Grinding Gage, Micrometer/Boring Head, Lathe Center, Grinding Vise, Precision Step Block, 1-2-3 Block, Precision Angle Plate, V-Block, Parallels, Sharpen Thread Tap, Sharpen Thread Die, Grind a Form Tool, and Grinding Fixture for Thread Tool. The job sheet for each project lists operator's job title, project name, time needed, related drawing number, performance objectives, operations, equipment, and materials needed; these are followed by a two-column section, the left column listing the project procedures and the right column containing techniques and related information. The final section contains 55 drawings. (HD)

Documents acquired by ERIC include many informal unpublished materials not available from other sources. ERIC makes every effort to obtain the best copy available. Nevertheless, items of marginal reproducibility are often encountered and this affects the quality of the microfiche and hardcopy reproductions ERIC makes available via the ERIC Document Reproduction Service (EDRS). EDRS is not responsible for the quality of the original document. Reproductions supplied by EDRS are the best that can be made from

ED 134735

Surface Grinder Operator

INSTRUCTOR'S GUIDE

Part of
SINGLE-TOOL SKILLS PROGRAM
MACHINE INDUSTRIES OCCUPATIONS



U.S. DEPARTMENT OF HEALTH,
EDUCATION & WELFARE
NATIONAL INSTITUTE OF
EDUCATION

THIS DOCUMENT HAS BEEN REPRO-
DUCED EXACTLY AS RECEIVED FROM
THE PERSON OR ORGANIZATION ORIGIN-
ATING IT. POINTS OF VIEW OR OPINIONS
STATED DO NOT NECESSARILY REPRESENT
OFFICIAL NATIONAL INSTITUTE OF
EDUCATION POSITION OR POLICY.

The University of the State of New York
THE STATE EDUCATION DEPARTMENT
Bureau of Continuing Education Curriculum Development
Bureau of Secondary Curriculum Development
Albany, New York 12224
1973

CE 007 501

THE UNIVERSITY OF THE STATE OF NEW YORK
Regents of the University (with years when terms expire)

1984	Joseph W. McGovern, A.B., J.D., L.H.D., LL.D., D.C.L. Chancellor	New York
1985	Everett J. Penny, B.C.S., D.C.S., Vice Chancellor	White Plains
1978	Alexander J. Allan, Jr., LL.D., Litt.D.	Troy
1973	Charles W. Millard, Jr., A.B., LL.D., L.H.D.	Buffalo
1987	Carl H. Pforzheimer, Jr., A.B., M.B.A., D.C.S., H.H.D.	Purchase
1975	Edward M. M. Warburg, B.S., L.H.D.	New York
1977	Joseph T. King, LL.B.	Queens
1974	Joseph C. Indelicato, M.D.	Brooklyn
1976	Mrs. Helen B. Power, A.B., Litt.D., L.H.D., LL.D.	Rochester
1979	Francis W. McGinley, B.S., J.D., LL.D.	Glens Falls
1980	Max J. Rubin, LL.B., L.H.D.	New York
1986	Kenneth B. Clark, A.B., M.S., Ph.D., LL.D., L.H.D., D.Sc.	Hastings on Hudson
1982	Stephen K. Bailey, A.B., B.A., M.A., Ph.D., LL.D.	Syracuse
1983	Harold E. Newcomb, B.A.	Owego
1981	Theodore M. Black, A.B., Litt.D.	Sands Point

President of the University and Commissioner of Education
Ewald B. Nyquist

Executive Deputy Commissioner of Education
Gordon M. Ambach

Deputy Commissioner for Elementary, Secondary, and Continuing Education
Thomas D. Sheldon

Associate Commissioner for Instructional Services
William L. Bitner

Assistant Commissioner for Instructional Services (General Education)
Bernard F. Haake

Director, Division of School Supervision
Gordon E. Van Hooft

Chief, Bureau of Secondary Curriculum Development

Chief, Bureau of Continuing Education Curriculum Development
Herbert Bothamley

Assistant Commissioner for Occupational Education
Robert S. Seckendorf

Director, Division of Occupational Education Instruction
Robert H. Bielefeld

Chief, Bureau of Trade and Technical Education
Carl G. Benenati

THE UNIVERSITY OF THE STATE OF NEW YORK
 THE STATE EDUCATION DEPARTMENT
 ALBANY, NEW YORK 12224

ASSISTANT COMMISSIONER FOR
 OCCUPATIONAL EDUCATION

DIVISION OF OCCUPATIONAL EDUCATION INSTRUCTION

BUREAU OF TRADE & TECHNICAL EDUCATION

518: 474-3973

ASSOCIATE COMMISSIONER FOR
 RESEARCH AND EVALUATION

DIVISION OF RESEARCH

BUREAU OF OCCUPATIONAL EDUCATION RESEARCH

518: 474-6386

TEACHER EVALUATION OF SURFACE GRINDER OPERATOR

The curriculum guide containing this form represents a new format. The purpose of this evaluation is to obtain your reaction to this format. This guide is the second to be published in the Single-Tool Skills Program, a series in which publication of several more guides is expected. (The first one, published in 1972, was *Engine Lathe Operator*.) Additional copies of these curriculum guides may be obtained by school officials from the Publications Distribution Unit.

AFTER COMPLETING THIS FORM RETURN IT TO Bureau of Occupational Education Research, New York State Education Department, Albany, New York 12224.

EVALUATE THE FOLLOWING COMPONENTS OF THE ENCLOSED CURRICULUM GUIDE BY CHECKING ONE OF THE COLUMNS AT THE RIGHT FOR EACH ITEM.

1. The approach as explained on pages iii and iv.
2. The total allotment of 96½ hours (on page vii) as suggested time and not a requirement.
3. The time shown for each job (pages vi and vii) as an adequate average.
4. The clarity of the Introduction on pages 2 and 3.
5. Inclusion of the content of the PROCEDURE column in each job. (See pages 13-17, for example.)
6. Inclusion of the content of the TECHNIQUES AND RELATED INFO. column in each job.
7. The looseleaf tear-out binding method.
8. The indepth treatment of shop jobs rather than having more shop jobs without details.

	VERY GOOD	GOOD	POOR	VERY POOR
1.				<input checked="" type="checkbox"/>
2.				
3.				
4.				
5.				
6.				
7.				
8.				

ANSWER THESE QUESTIONS:

9. Are there serious flaws in the content of the Introduction on pages 2 and 3? (If your answer is "Yes," explain in the blank space on the next page.)

YES NO

9. _____

10. Do you feel that the time allotments on pages vi and vii are sufficient for minimum training to insure employability in the particular skills area? (If your answer is "No," explain.)

10.

11. If you had a group of men to train in operating a surface grinder, would you find this publication helpful?

11.

If the answer to No. 11 is "Yes," mention the parts of the publication that would be most helpful. (Use the blank space below or a separate sheet of paper.) If the answer is "No," explain what is lacking in the publication. Also give any other explanation needed.

YES NO

12. Do you know someone who should have received this curriculum guide but has not? (If so, give us his name and school mailing address.)

12.

Please use the space below to explain any items above that need explanation and to add any other comments you have. Identify each explanation and comment, if possible, with the number of the item it applies to. Be as specific as possible. Use an extra sheet of paper if necessary.

CATEGORY OF EVALUATOR (Mark more than one category in each list if applicable.)

- Program Type
- Secondary school
 - Adult program
 - MDTA
 - Community college

- Your Full-Time Employment
- Teacher
 - School administrator
 - Machine shop worker
 - Other (Specify) _____

OPTIONAL: Name (please print) _____

Name and address of the school where you teach a shop course (or "courses")

Date form filled in, _____

Foreword

The *Surface Grinder Operator* course contained in this book is intended to help fill the need for men trained to operate machine tools. The backgrounds of those who enter the course will cover a broad range of qualifications, but it is likely that many men with little education or experience will be included. Completion of this course alone, obviously will not make anyone a full-fledged machinist.

This course is the second one to be published in what is expected to be a series of instructor's guides in the Single-Tool Skills Program. (The first one, *Engine Lathe Operator*, was published in 1972.) Although written primarily as an adult course, the secondary level teacher can use the content in a course he might develop for his students. It was produced as a joint project of the two curriculum bureaus named on the title page.

The Single-Tool Skills Program is one of the programs in a broad plan covering machine industries occupations. The original plan was conceived by Robert S. Hunter, former associate in the Bureau of Trade and Technical Education. A number of teachers were involved in the overall planning for machine industries occupations, and also wrote material for the course guides. They are Elek D. Csont, Seneca Vocational High School, Buffalo; Jack Grossman, Alexander Hamilton High School, Brooklyn; Alfred Kagan, Sewanhaka High School, Floral Park; Gilbert Pultz, Jefferson Vocational and Technical Center, Watertown; William G. Stewart, North Senior High School, Binghamton; William F. Tiedemann, Central Technical High School, Syracuse; and Joseph Waldinsperger, College of Continuing Education, Rochester Institute of Technology, Rochester.

Other members of the State Education Department took part in the overall planning, and in the further detailed planning which resulted in the production of this publication. They are E. Noah Gould, associate in the Bureau of Continuing Curriculum; G. Earl Hay, supervisor in the Bureau of Secondary Curriculum; Edward Shattuck, former associate in the Bureau of Trade and Technical Education; and Charles A. Stebbins, associate in the last-named bureau.

Messrs. Kagan, Pultz, Stewart, and Tiedemann wrote the *Surface Grinder Operator* course contained in this booklet. Mr. Gould directly supervised the writing and edited the manuscript, and is in general charge of the Single-Tool Skills series.

HERBERT BOTHAMLEY, *Chief*
Bureau of Continuing Education
Curriculum Development

GORDON E. VAN HOOFT, *Director*
Division of School Supervision

Message to the Instructor

This *Surface Grinder Operator* course is expected to help meet the need for trained operators in metalworking. The course is suitable for use in the adult education programs of school districts, in Manpower Development and Training programs, and in secondary schools.

Anyone who completes this course successfully will be qualified for an entry-level job as operator of a surface grinder. After completing the course some students may go on to other single-tool courses and become qualified to operate more than one machine tool. It is even possible that a student with outstanding ability, by completing the courses for several machine tools, could become a machinist.

The 17 shop projects in this course are listed on pages vi and vii. There is no requirement that any student complete all projects, or even all jobs within any project. The instructor may determine which projects and jobs a given student should complete, and may if he wishes, use others not included in this book.

The teacher for this course would ideally be a person with not only good training and experience in machinist skills, but also several years of teaching experience. The best sources from which to draw teachers are the faculties of schools giving machine tool courses, and the ranks of those employed as machinists and supervisors of machinists.

Adult education directors, occupational education directors, and teachers who have any questions or comments should direct them to either the Bureau of Trade and Technical Education or to one of the bureaus named on the title page.

CARL G. BENENATI, *Chief*
Bureau of Trade and
Technical Education

ROBERT H. BIELEFELD, *Director*
Division of Occupational Education

Contents

	Page
Foreword	iii
Message to the Instructor	iv
Shop Projects	vi
Drawings for Shop Projects	viii
INTRODUCTION	1
GENERAL JOB CONTENT	4
JOB SHEETS FOR SHOP PROJECTS	12
BIBLIOGRAPHY	57
DRAWINGS FOR SHOP PROJECTS	58

MACHINE INDUSTRIES OCCUPATIONS
 SINGLE-TOOL SKILLS PROGRAM
 SURFACE GRINDER OPERATOR COURSE

SHOP PROJECTS

<u>Project No.</u>	<u>Time (hrs.)</u>	<u>Page</u>
I. Scriber		
Job 1. Scriber	3	13
II. Drill Stand		
Job 1. Drill Stand	4	15
III. Arbor Press		
Job 1. Base	3	18
Job 2. Rack	1	20
Job 3. Column	2	21
IV. Surface Gage		
Job 1. Base	3	22
Job 2. Adjustment Bar	2	24
V. Tool Bit Grinding Gage		
Job 1. Tool Bit Grinding Gage	2	25
VI. Micrometer Boring Head		
Job 1. Plate	1	26
Job 2. Dovetail Blocks	3	27
Job 3. Dovetail Slide	3	28
VII. Lathe Center		
Job 1. Lathe Center	1	29
VIII. Grinding Vise		
Job 1. Base	8	31
Job 2. Sliding Jaw	5	34
IX. Precision Step Block		
Job 1. Precision Step Block	5	36
X. 1-2-3 Block		
Job 1. 1-2-3 Block	8	38
XI. Precision Angle Plate		
Job 1. Precision Angle Plate	6	40
XII. V-Block		
Job 1. V-Block	6	42
Job 2. Clamp	7	44
XIII. Parallels		
Job 1. Parallels	6	46

<u>Project No.</u>	<u>Time (hrs.)</u>	<u>Page</u>
XIV. Sharpen Thread Tap Job 1. Sharpen Thread Tap	3	48
XV. Sharpen Thread Die Job 1. Sharpen Thread Die	$2\frac{1}{2}$	50
XVI. Grind a Form Tool Job 1. Grind Form Tool for Screwdriver Handle	2	52
XVII. Grinding Fixture for Thread Tool Job 1. Grinding Fixture for Thread Tool	10	54
Total time for shop projects	$96\frac{1}{2}$ hrs.	

MACHINE INDUSTRIES OCCUPATIONS
SINGLE-TOOL SKILLS PROGRAM
SURFACE GRINDER OPERATOR COURSE

DRAWINGS FOR SHOP PROJECTS

DWG. NO.	TITLE OF DRAWING	SURFACE GRINDER		Page
		PROJ- ECT	JOBS COVERED	
22	Micrometer Boring Head: Assembly	VI	1,2,3	59
22.1	Micrometer Boring Head: Plate		1	60
22.2	Micrometer Boring Head: Dovetail Blocks		2	61
23	Micrometer Boring Head: Dial, Shank, and Stop Pin		None	62
24	Micrometer Boring Head: Dovetail Slide		3	63
25	Surface Gage: Assembly	IV	1,2	64
26	Surface Gage: Details		1,2	65
27	Arbor Press: Assembly	III	1,2,3	66
28	Arbor Press: Gear Shaft, Rack Pad, and Rack		2	67
29	Arbor Press: Table		None	68
30	Arbor Press: Sleeve, Table Pin, and Cover Plate		None	69
31	Arbor Press: Handle and End		None	70
32	Arbor Press: Column		3	71
33	Arbor Press: Base		1	72
35	Lathe Center, Morse Taper	VII	1	73
36	Grinding Vise: Assembly	VIII	1,2	74
37	Grinding Vise: Lead Screw Nut		None	75
38	Grinding Vise: Lead Screw and End Nut		None	76
39	Grinding Vise: Base		1	77
40	Grinding Vise: Sliding Jaw		2	78
41	Scriber	I	1	79
42	Drill Stand	II	1	80
43	Tool Bit Grinding Gage	V	1	81
44	Precision Step Block	IX	1	82
45	1-2-3 Block	X	1	83
46	Precision Angle Plate	XI	1	84
47	V-Block: V-Block	XII	1	85
48	V-Block: Clamp		2	86
49	V-Block: Clamp Screw		None	87
50	Parallels	XIII	1	88
51	Sharpen Thread Tap	XIV	1	89
52	Sharpen Thread Die	XV	1	90
53	Form Tool for Screwdriver Handle	XVI	1	91
54	Grinding Fixture for Thread Tool: Base	XVII	1	92
55	Grinding Fixture for Thread Tool: Nut and Bolt		None	93

Introduction

As shown in the Contents, this *Surface Grinder Operator* course consists of this Introduction, General Job Content (which explains what the operator's job includes), Shop Projects, and the drawings for the projects. The course covers the operation of the surface grinder only.

The job for which the trainee would be qualified upon completion of this course is referred to in the Dictionary of Occupational Titles (under the code number 603.280) as grinder operator, surface, tool; grinder, hand; precision grinder, surface; rotary-surface grinder; surface grinder; surface grinder, tool; and surface-grinding-machine hand.

The general objective of the course is to train men, in a comparatively short time, to be placed as Surface grinder operators. The course is not intended to give a broad training in metalworking, but only the skill to operate one kind of metalworking machine. By keeping the objective narrow, the training time is kept to a minimum, and the trainees are made available for work without a long delay.

One important purpose of this course is to help those with very little background. The prerequisites for admission to an adult course should be broad enough so none will be barred who could be made employable. The operating authorities for each program, school, and school district have the responsibility for determining the prerequisites for such a course, and can adapt them to any special local conditions.

The *minimum* prerequisites we suggest for a trainee (and they are not mandatory) are that he have enough ability to understand and follow the course instructions (*either* written or oral), so he can produce the simplest workpiece included in the course. Such a trainee will, perhaps, be able to qualify only as a production machine operator, where all the machine setups are made for him. Another trainee with more background will possibly qualify for jobs requiring more skill, such as precision surface grinder operator.

We believe that enough general information about the job and more than enough shop projects are included for the trainee to reach the general objective of the course. All essential surface grinder skills are used in the shop projects a number of times. The schools may use everything in the course, they may select only some of the material, they may make changes in it, and they may use other material not contained here. They may also determine the length of the class periods, their frequency, and the total amount of time to be spent in training. For those that need a guide: A typical adult night class runs 2½ to 3 hours, either once or twice a week, for 30 weeks.

The drawings in this course are part of a serially numbered set beginning with No. 1, which appears in the *Engine Lathe Operator* course. The numbers continue through the drawings of this course and will be continued further in other courses in the Single-Tool Skills Program to be published later. Drawings in this course which are also in the *Engine Lathe* course are reproduced here with the same drawing numbers. Some drawings appear in this book which are not needed for the shop projects of this course. They are included here for the convenience of keeping together all the drawings of an assembly. Those in this publication run from 22 through 55 of the series.

In the drawings all dimensions are in inches unless otherwise indicated. As a shop project is assigned to a student, we recommend that the instructor give him copies of the job sheet and applicable drawings. The pages of the book should be used as masters for making the copies needed, but they must be kept clean and should not be used by anyone working on a machine.

Each drawing has four blocks for information at the bottom, with the one at the upper right blank. We suggest that the instructor have the student write the numbers of the project and job for which he is using the drawing in that blank space. Each job sheet has the words *Unit No.* in the upper left corner, but no number is given. The instructor may wish to write a number in this space to fit in with his own method of organizing his classroom and shop work.

Drawing 35 contains tables giving several different sets of dimensions for the workpieces pictured. These tables permit the instructor to select the set of dimensions which he finds best for each student or for the conditions under which his class operates.

Many of the workpieces on which surface grinding is to be done in this course are those produced in other courses in the Single-Tool Skills series, such as those covering milling, drilling, and heat treating. (See pages 15 and 20, for example.) If a given workpiece is not available as the output of another course in his shop, it is the instructor's responsibility to obtain the workpiece. He can do this by making it himself or by obtaining it as the output of courses given elsewhere.

The job sheets show two references which are especially recommended for the machine work. The bibliography gives the complete citations for these two books and also contains additional references.

Following are the abbreviations used in the text and drawings for this course.

ACT.	actuate	H.S.	high-speed
ACTG.	actuating	HT.	height
ALUM.	aluminum	LG.	long
ASSY.	assembly	LGTH.	length
CHAM.	chamfer	MATL.	material
CBORE.	counterbore	MED.	medium
CRS.	cold rolled steel	PT.	part
CSK.	countersink	R or RAD.	radius
DIA.	diameter	REQD.	required
DP.	deep	R.H.	right-hand
DP	diametral pitch	SCR.	screw
DR.	drill	SOC.	socket
DR. OR DR. ROD	drill rod	SPEC.	specifications
EQ. SP.	equally spaced	SPHER.	spherical
FAO	finish all over	STL.	steel
HD	head	SQ.	square
HDL.	handle	TYP.	typical
HGT.	height	W.	width
HEX.	hexagonal		

General Job Content

CONTENT OUTLINE

TEACHING POINTS AND TECHNIQUES

- I. Types of Grinders
- Introduce the various kinds of surface grinders:
1. vertical spindle, reciprocating table
 2. horizontal spindle, rotary table
 3. horizontal spindle, reciprocating table
- Explain that the above machines may use the electrolytic grinding system.
- II. Machine Parts
- Disclose that some types of spindles are
1. sealed cartridge, direct drive
 2. sealed cartridge, belt drive
- Explain that the types of feed mechanisms used for table, transverse, and vertical movements are either hydraulic or mechanical.
- Note that the lead screw dials have different graduations, such as: .0001", .001", and .0005".
- Point out where locks are located, such as on the spindle head and the saddle.
- Show the location of the table trip dogs and stops, and how they are regulated and set.
- Demonstrate how hydraulic feeds are set and regulated for cross feed, longitudinal feed, and down feed.
- III. Machine Accessories
- Explain that accessories are available for surface grinders, such as
1. high speed grinding attachment
 2. wheel balancing stands
 3. radius and angle truing attachments
- A. Toolholding
- Call attention to the value of interchangeable wheels and quills, for example, in form grinding and grinding of work in confined areas.
- Mention the use of segmented wheel chucks and the advantages of segmented wheels for vertical spindle surface grinding machines.
- B. Work holding
- Develop an understanding that vises of both plain and universal design are available. Explain chucks designed for flat nonferrous metals.
- Point out that there are auxiliary tables available for mounting work. Such tables permit the grinding of plain or compound angles.
- Mention that the tables referred to above are

CONTENT OUTLINE

IV. Cutting Tools

TEACHING POINTS AND TECHNIQUES

available with angular graduations or sine table provisions, and may be equipped with magnetic chucks.

Explain that there are other work holding devices available, such as indexing centers, fixtures, steel angle plates, and V-blocks.

Point out that there are various types of magnetic chucks, such as permanent and electromagnetic, and that they are either rectangular or round.

State that some of the grinding wheel abrasives are diamond, aluminum oxide, and silicon carbide.

Point out that there are standard shapes of grinding wheels, for example

1. type 7, wheel recessed on both sides
2. type 1, plain straight wheel

Further discuss the composition of grinding wheels, including

1. grit size
2. bonding materials
3. structure
4. grade

Call attention to the fact that grinding wheels are sized by hole diameter, width of face, and outside diameter.

Demonstrate the proper procedures for mounting grinding wheels, such as disk type wheels, diamond wheels, and plain wheels.

Show how large diameter wheels can be balanced, using a balancing stand. Indicate that some grinding wheel spindles have a built-in balancing system.

Emphasize that for wet grinding you should allow the coolant to flow on the wheel when dressing. When grinding is done dry, the wheel must be dressed dry. Mention that manufacturer's specifications for dressing diamond wheels must be observed.

Interpret the meaning of diamond wheel terms, such as concentration, bond, and grit size.

Discuss the differences in dressing, truing, and shaping grinding wheels by various methods.

CONTENT OUTLINE

TEACHING POINTS AND TECHNIQUES

Differentiate between the various types of wheel dressers and their application. Present as examples

1. abrasive wheels or sticks
2. mechanical precision dressers
3. diamond wheel brake dressers

State the importance of truing a diamond grinding wheel with an indicator.

Explain the principle of crush wheel dressing when applied to form grinding. Elaborate on some related items such as

1. crush wheel size and composition
2. grinding wheel types
3. speeds and feeds for crushing or grinding

Furnish grinding wheel selection charts and show how they are applied in the selection of a grinding wheel for a particular grinding problem.

V. Measurement and Inspection

List and explain the various types of measuring tools. Suggest that these could include micrometers (calibrated in .0001"), indicators, comparators, and profilometers.

Call attention to the fact that optical comparators are available in various magnifications, for example, 10 power and 50 power.

VI. Blueprint Reading

Introduce and cover all necessary blueprint reading. For example

1. theory of orthographic projection
2. language of lines
3. sectional views
4. tolerances
5. symbols

VII. Speeds and Feeds

Define the meaning of surface speed in relation to grinding wheels. Discuss proper crossfeed rates for rough and finish grinding.

Consider and compare the depth of cuts that may be taken on vertical spindle machines and horizontal spindle machines.

Continue by explaining how longitudinal or rotary table speeds will affect grinding wheel wear, and surface finish.

Discuss the fact that the amount of contact area on the workpiece determines wheel composition

CONTENT OUTLINE

TEACHING POINTS AND TECHNIQUES

VIII. Trade Mathematics

selections. This affects hardness, grit size, and structure.

Point out that rotary grinders have variable table speeds and in-feeds.

Introduce and cover all necessary trade mathematics, such as

1. surface speed formulas
2. r.p.m. formulas
3. trigonometric functions

IX. Coolants

Present information defining the use and kinds of cutting fluids and the desired advantages of the cutting fluids, such as high cutting speed, good surface finish, and longer tool life.

Establish that some functions of cutting fluids are lubricating, cooling, and antiwelding.

Point out where the coolant flow should be directed in relation to the work and grinding wheel.

Continue by explaining that dirty coolant will affect the surface finish by leaving scratch marks on the job.

Explain the ratio of water to soluble oil concentrate in mixing soluble coolants.

Tell about directing coolant flow by some methods, such as spray mist, flush (flood), and through the wheel.

X. Care and Maintenance

Provide some information concerning the care and maintenance of the type of surface grinder in use, covering

1. cleaning of machine
2. cleaning of chucks
3. mounting of wheel sleeves
4. making machine adjustments

Utilize the standard operations and repair manual for maintenance information on the grinder in use. It includes, for example, lubrication, and how the wheel spindle is removed.

State that the coolant filter must be kept clean to obtain good coolant flow and good finishes on work surfaces.

Cite the procedures for resurfacing a magnetic chuck. Include the method of checking the chuck

CONTENT OUTLINE

TEACHING POINTS AND TECHNIQUES

for accuracy with an indicator.

Show how the guide rail is ground parallel with the work table and demonstrate how to check it with an indicator.

Note that magnetic chucks not in use should be thoroughly cleaned and greased to protect the magnetic poles from dirt and moisture. Mention that light burrs on magnetic chucks can be removed by hand stoning.

XI. Safety

Introduce the following safe working practices for operating grinding machines:

1. Wear close fitting clothes.
2. Wear safety glasses.
3. Make sure all guards are in place.
4. Keep hands away from moving parts.
5. Know how to operate the controls.

Discuss particular dangers to avoid when operating the surface grinder, such as the following:

1. Make sure that the work is securely held on the magnet. Block small pieces and support tall pieces.
2. Make sure that the grinding wheel is properly mounted and has no flaws or cracks in it.
3. Never attempt to clean the magnetic chuck, or mount or remove work, unless the wheel is out of the way.
4. Always observe the grinding and dressing actions from the right-hand side of the machine, to avoid flying particles.
5. Know that the wheel clears the work before starting the grinder.
6. Be sure that you know the safe operating speed of the wheel you are using.

XII. Trade Terms

Explain all terms which are pertinent to this unit of the course, such as sparking out, glazing, and loading.

XIII. Operations

A. Grinding flat surfaces

Show how to properly place material on the magnetic chuck to grind a flat surface.

Point out that long thin pieces of work are best set diagonally across the chuck, and that alternately turning the piece over and making light cuts will reduce the chance of warpage due to heat.

CONTENT OUTLINE

TEACHING POINTS AND TECHNIQUES

- Demonstrate how to use magnetic parallels on a vise when grinding workpiece of unusual shape.
- B. Parallel surface grinding Explain that work can be ground parallel by various methods, such as
1. holding directly on the magnetic chuck
 2. holding in a grinding vise
 3. clamping to an angle plate
 4. using double-faced masking tape
- Mention the use of magnetic parallels that are set on the magnetic chuck, ground parallel, and then used as the surface for mounting work.
- C. Grinding square Tell about the procedure for squaring rectangular pieces of work using precision grinding vises, angle plates, and squaring fixtures.
- Caution the students to remove all burrs before making the next setting on the holding device.
- Mention the use of a V-block for grinding the end of a round piece of work square.
- D. Angular grinding Suggest that the following holding devices may be used to grind angular surfaces: fixture, toolmaker's vise, magnetic sine table, and angle plate.
- Explain that compound angles are ground by the use of a compound sine bar table equipped with a magnetic chuck.
- E. Form grinding Discuss devices for form dressing a grinding wheel, such as
1. radius and angle wheel dresser
 2. template form dresser
 3. optical form dresser
 4. crush form dresser
- Continue by stating that there are two types of template form dressers: those mounted on the spindle and those mounted on the table.
- F. Side grinding Demonstrate how side walls can be ground by undercutting the sides of the grinding wheel.
- G. Cutoff grinding State that hardened steel parts are usually cut off by using a resonoid or rubber wheel.
- H. Cylindrical grinding Point out that it is possible to do cylindrical grinding operations by mounting an attachment

CONTENT OUTLINE

I. Internal grinding

TEACHING POINTS AND TECHNIQUES

designed for this type of work.

Discuss various operations that can be performed internally by the use of the high speed surface grinding attachment. These include

1. grinding slots and surfaces which do not permit the use of a large wheel
2. grinding internal radii
3. blending radii to an angular or straight plane

Show how the fixture, quills, and grinding wheels are mounted.

J. Cutter grinding

State that cutter grinding is done on the surface grinder. Mention the following examples:

1. form grinding lathe tools
2. grinding tools for turret lathes
3. grinding milling cutters (with attachment)

Continue by showing that tools such as taps, reamers, and form cutters can be ground using index centers.

Job Sheets for Shop Projects

Unit No. Operator's Job Title: Surface Grinder Operator

Project I Project Name: Scriber

Job No. 1 Job Name: Scriber

D.O.T. No. 603.280

Drawing No. 41

Time: 3 hours

Performance Objectives:

Using only the equipment, materials, and operations listed here, the student will be able to produce the piece shown on the drawing in accordance with the time and accuracy requirements specified. After completing this job the student will be able to complete similar jobs with like specifications.

Operations:

1. Wheel dressing
2. Parallel grinding
3. Grinding square
4. Angular grinding

Equipment:

Surface grinder	Protractor
Grinding wheel	Micrometer
Diamond wheel dresser	Oilstone
Angle plate	Parallel clamps
Surface gage	
Indicator	

Materials:

High speed tool bit
 $\frac{1}{4}$ " x $\frac{1}{4}$ " x $2\frac{3}{4}$ "

Selected references: *

Krar. & Oswald, *Grinding Technology*
McCarthy & Smith, *Machine Tool Technology*; 3d edition

PROCEDURE

TECHNIQUES AND RELATED INFO.

1. Select stock and deburr.
2. Mount and dress grinding wheel sharp and true.
3. Locate part on chuck, contact with wheel, and grind to clean up surface.
4. Reverse part and grind opposite side to .245" dimension.
5. Obtain angle plate and parallel clamp and set up so unground side protrudes above top of angle.
6. Grind third side to clean up.
7. Locate piece on magnet on third surface and grind fourth side to .185" dimension.
2. Use shop practice for dressing wheel. Suggested wheel is A46-18V.
3. Use light downfeed, maximum of .001" per cut, to prevent overheating part.
4. Take a reference cut across second side, remove part, and check with micrometer to hold finished size. Have wheel out of the way.
5. Use surface gage and indicator on surface plate to make part level for grinding.
6. Set wheel to spark contact and use light cuts.
7. Spark contact and take a reference grind. Remove from chuck and check size with micrometer to hold finished dimension. Have wheel out of the way.

*Full reference citations are given in the bibliography.

8. Obtain angle plate and clamp, then set up workpiece to grind sharp edge to a 65° angle.
9. Remove burrs with stone and submit for inspection and grade.

8. Block the work with parallel blocks to hold securely, and use very light finish to grind sharp edge at 65° angle.

Unit No: Operator's Job Title: Surface Grinder Operator

Project II Project Name: Drill Stand

Job No. 1 Job Name: Drill Stand

D.O.T. No. 603.280

Drawing No. 42

Time: 4 hours

Performance Objectives:

Using only the equipment, materials, and operations listed here, the student will be able to produce the piece shown on the drawing in accordance with the time and accuracy requirements specified. After completing this job the student will be able to complete similar jobs with like specifications.

Operations:

1. Surface grinding
2. Angle grinding

Equipment:

Surface grinder
Grinding wheel
Tilting vise
Diamond wheel dresser
Square

Protractor
Steel rule

Materials:

Cast aluminum
1 1/2" x 3 1/2" x 1 1/2"
workpiece from milling
and drilling operations

Selected references:

Krar & Oswald, *Grinding Technology*
McCarthy & Smith, *Machine Tool Technology*; 3d edition

PROCEDURE

TECHNIQUES AND RELATED INFO.

1. Mount straight wheel.
2. Dress wheel.
3. Set up to grind the bottom surface of the workpiece.
4. Grind the bottom surface.
5. Set up to grind one adjacent side.

1. 1/2" x 7" No. 37C24-KVK wheel is recommended.
3. Place the workpiece in the vise with the bottom surface up. Place the vise on the magnetic chuck to grind the workpiece lengthwise.
4. Grind to clean up with a good finish.
5. Leave the vise in the same position as in the previous operation. Place the workpiece in the vise with the bottom finished surface against the solid jaw, and a sheet of paper between to prevent scratching the finished surface.

- On all setup operations that follow, place a sheet of paper between each finished surface of the workpiece and the vise.
6. Grind the adjacent side.
 7. Set up to grind one end.
 8. Grind the end.
 9. Set up to grind the other end.
 10. Grind the end.
 11. Set up to grind the unfinished side surface.
 12. Grind the side.
 13. Set up to grind the top surface.
 14. Grind the top surface.
 15. Set up to grind one long beveled edge.
6. Grind to clean up with a good finish.
 7. Leave the vise in the same position as in the previous operation. Place the workpiece on end with the finished bottom surface against the solid jaw, and the finished side surface at right angles to the surface of the magnetic chuck.
 8. Grind to clean up with a good finish.
 9. Leave the vise in same position as in the previous operation. Place the finished end of the workpiece down in the vise with the bottom of the workpiece against the solid jaw.
 10. Grind to the overall length of 6". Dress the wheel when necessary to obtain a good finish.
 11. Leave the vise in the same position as above. Place the bottom of the workpiece against the solid jaw with the finished side down in the vise.
 12. Grind to a width of 3".
 13. Leave the vise in the same position as above. Place the side of the workpiece against the solid jaw with the top surface up.
 14. Grind to an overall height of $1\frac{1}{2}$ ".
 15. Leave the workpiece in the same position as in the preceding step. Tilt the vise to an angle of 45° .

16. Grind the $\frac{1}{16}$ " x 45° bevel.
17. Set up to grind the second long beveled edge.
18. Grind the second long beveled edge to $\frac{1}{16}$ " x 45°.
19. Set up to grind the bevel on one end.
20. Grind the $\frac{1}{16}$ " x 45° bevel.
21. Set up to grind the bevel on the opposite end.
22. Grind the $\frac{1}{16}$ " x 45° bevel.
23. Remove all sharp edges and submit for inspection and grade.
17. Turn the workpiece in the vise 180° so that the second long beveled edge is in position for grinding.
19. With the vise in the same position as in step 15, set the workpiece on end in the vise.
21. Leave the vise in the same position as in step 19. Set the workpiece in the vise with the finished end down in the vise.

Unit No. Operator's Job Title: Surface Grinder Operator

Project III Project Name: Arbor Press

Job No. 1 Job Name: Base D.O.T. No. 603.280

Drawing Nos. 27, 33

Time: 3 hours

Performance Objectives:

Using only the equipment, materials, and operations listed here, the student will be able to produce the piece shown on the drawing in accordance with the time and accuracy requirements specified. After completing this job the student will be able to complete similar jobs with like specifications.

Operations:

1. Flat surface grinding
2. Side grinding
3. Wheel dressing
4. Fitting for assembly
5. Angular grinding
6. Angular wheel dressing

Equipment:

Surface grinder	Dial indicator
Grinding wheel	Mill file
Diamond wheel dresser	Sine bar
Angle plate	Gage blocks
Parallel clamps	Angle wheel dresser
Surface gage	$\frac{1}{2}$ " parallel
Steel rule	

Materials:

CRS C1020, 1" x 3" x $\frac{3}{4}$ "

Selected references:

Krar, & Oswald, *Grinding Technology*

McCarthy & Smith, *Machine Tool Technology*; 3d edition

PROCEDURE

TECHNIQUES AND RELATED INFO.

1. Select part and remove all burrs.
2. Select and mount grinding wheel.
3. Use shop procedure to dress and true grinding wheel.
4. Clean magnetic chuck, locate large flat surface of the workpiece flat in center area, and turn on the magnet.
5. Set table stops to correct positions and set crossfeed for medium feed.
6. Start the grinding wheel and lower the wheel head until the wheel just sparks the work.
7. Start the table travel and feed the entire width of the work.
8. Grind to clean up; take off .001" per cut.
9. Stop the table travel and move the wheel out of the way.
10. Release magnet, remove work, and clean chuck.
2. Suggested wheel is 23A46-J 8VBE.
4. Be sure chuck is clean and has no nicks or burrs on the surface. Check magnet for holding power.
5. Wheel travel should be about 1" beyond the ends of the work.
6. Have wheel revolving when it comes close to the workpiece; make contact at the high point.
7. This checks for high spots.
9. Never try to handle work close to the grinding wheel.

PROCEDURE

TECHNIQUES AND RELATED INFO.

11. Relocate part on ground surface and grind other side parallel, down to 1" dimension.
 12. Remove part from chuck and deburr sharp edges.
 13. Set up to grind the sides of the 1" slot as follows: Place the workpiece on the surface plate and clamp to a suitable angle plate with two clamps.
 14. Use shop practice to undercut the grinding wheel for side grinding.
 15. Locate the angle plate on the magnetic chuck and grind .010" on one side of the 1" slot.
 16. Reverse the angle plate on the magnetic chuck and grind the other side of the slot to fit the mating part.
 17. Remove workpiece from the angle plate and deburr sharp edges.
 18. Set up sine bar to 37°. Position $3\frac{1}{4}$ " side on sine bar and clamp to angle plate.
 19. Grind the angular surface to $\frac{3}{4}$ " x 1" dimensions.
 20. Reverse part, position other side on sine bar, and clamp to angle plate.
 21. Grind second angular surface to $\frac{3}{4}$ " x 1" dimensions.
 22. Remove part and deburr sharp edges.
 23. Set up angular wheel dresser and dress wheel to 45° angle.
 24. Locate part on magnetic chuck with a $\frac{1}{2}$ " parallel against the back rail and grind the 45° chamfer on top edges.
 25. Remove all sharp edges and submit for inspection and grade.
13. Use parallels if necessary to elevate the 1" slot above the top of the angle plate.
 14. Use hand held wheel dresser or one located on magnetic chuck to undercut side of wheel. (No. 12 dish wheel may be substituted.) Avoid flying particles.
 15. Use the back rail of the magnetic chuck for proper alignment.
 17. Clean magnetic chuck and angle plate.
 18. Check alignment carefully when clamping work to angle plate.
 24. Use parallel to align work-edge for each chamfer.

Unit No. Operator's Job Title: Surface Grinder Operator
Project III Project Name: Arbor Press
Job No. 2 Job Name: Rack D.O.T. No. 603.280
Drawing Nos. 27, 28 Time: 1 hour

Performance Objectives:

Using only the equipment, materials, and operations listed here, the student will be able to produce the piece shown on the drawing in accordance with the time and accuracy requirements specified. After completing this job the student will be able to complete similar jobs with like specifications.

Operations:

1. Wheel dressing
2. Grinding parallel

Equipment:

Surface grinder
Grinding wheel
Diamond wheel dresser
1" micrometer
Mill file

Materials:

C1020, $\frac{29}{64}$ " x $\frac{5}{8}$ " x $\frac{47}{8}$ "
piece from milling machine operation

Selected references:

Krar & Oswald, *Grinding Technology*
McCarthy & Smith, *Machine Tool Technology*; 3d edition

PROCEDURE

TECHNIQUES AND RELATED INFO.

1. Select part and remove sharp edges.
 2. Dress grinding wheel sharp and true.
 3. Locate part on magnetic chuck and grind first side to clean up $\frac{7}{16}$ " dimension.
 4. Locate ground surface on magnetic chuck and take a reference grind.
 5. Grind part to $\frac{7}{16}$ " dimension.
 6. Remove sharp edges and submit for inspection and grade.
2. Wheel 23A46-J8VBE is recommended. Use shop practice for dressing wheel.
 3. Check magnetic chuck for nicks or burrs.
 4. Check size with micrometer to establish amount to grind for finish.
 5. This part will be used as a gage to finish grind the column slot for assembly.

Unit No. Operator's Job Title: Surface Grinder Operator

Project III Project Name: Arbor Press

Job No. 3 Job Name: Column D.O.T. No. 603.280

Drawing No. 27.32 Time: 2 hours

Performance Objectives:

Using only the equipment, materials, and operations listed here, the student will be able to produce the piece shown on the drawing in accordance with the time and accuracy requirements specified. After completing this job the student will be able to complete similar jobs with like specifications.

Operations:

1. Wheel dressing
2. Side grinding

Equipment:

Surface grinder 1" Micrometer
Grinding wheel Parallel
Diamond wheel dresser Mill file

Materials:

CRS C1020, 1" x 3 $\frac{1}{4}$ " x 6"
piece from milling machine
operation

Selected references:

Krar & Oswald, *Grinding Technology*
McCarthy & Smith, *Machine Tool Technology*; 3d edition

PROCEDURE

TECHNIQUES AND RELATED INFO.

1. Select part and remove sharp edges.
 2. Dress grinding wheel for side grinding in a $\frac{7}{16}$ " slot.
 3. Clean magnetic chuck, locate parallel against back rail, and mount workpiece against parallel.
 4. Grind one side of slot to .281" wall thickness, .625" deep.
 5. Reverse part on chuck, locate parallel, and grind other side to sliding fit with mating part.
 6. Remove sharp edges and submit for inspection and grade.
2. No. 23A46-J8VBE wheel recommended. Wheel must be extra narrow to clear $\frac{7}{16}$ " slot. Use a dish wheel or specially dressed down straight wheel.
 3. Part must be parallel to table travel.
 4. Check size with micrometer and redress wheel if necessary. Side grinding requires light cuts and sparking out for accuracy.
 5. Use mating rack to gage finish size of slot.

Unit No.

Operator's Job Title: Surface Grinder Operator

Project IV

Project Name: Surface Gage

Job No. 1

Job Name: Base

D.O.T. No. 603.280

Drawing Nos. 25,26

Time: 3 hours

Performance Objectives:

Using only the equipment, materials, and operations listed here, the student will be able to produce the piece shown on the drawing in accordance with the time and accuracy requirements specified. After completing this job the student will be able to complete similar jobs with like specifications.

Operations:

1. Wheel dressing
2. Wheel mounting
3. Grinding parallel
4. Grinding square
5. Side grinding
6. Angular grinding

Equipment:

Surface grinder	Parallel clamps
Grinding wheels	Surface plate
Diamond wheel dresser	Surface gage
1" micrometer caliper	Indicator
Angle plate	Protractor
Steel rule	

Materials:

SAE 1020 piece from milling machine operation

Selected references:

Krar & Oswald, *Grinding Technology*
McCarthy & Smith, *Machine Tool Technology*; 3d edition

PROCEDURE

TECHNIQUES AND RELATED INFO.

- | | |
|--|--|
| 1. Select part and remove all sharp edges. | 1. Use part from milling machine. |
| 2. Dress grinding wheel sharp and true. | 2. No. 25A46-J8VBE wheel recommended. |
| 3. Locate part on magnetic chuck on side surface and grind to clean up. | 3. Clean magnetic chuck before setting up work; remove any burrs or nicks. |
| 4. Locate part on ground side and grind opposite side to 1.000". | |
| 5. Mount part on angle plate with bottom surface above the top of the angle plate. | 5. Level surface with indicator and clamp securely without distorting the milled slot. |
| 6. Grind bottom surface to clean up to a good finish. | |
| 7. Remove from angle plate, locate on magnetic chuck, and grind top surface to .940" dimension. | |
| 8. Locate on angle plate at 15° angle and grind first angular surface to 1" dimension from end. | 8. Use a protractor to set part at correct angle and clamp securely without distorting slot. |
| 9. Relocate part on angle plate at 15° angle and grind second angular surface until a .440" dimension is attained. | |

PROCEDURE

TECHNIQUES AND RELATED INFO.

10. Remove all sharp edges and locate part on magnetic chuck in line with back rail.
 11. Mount and dress grinding wheel for side grinding.
 12. Grind one side of slot to .270" dimension .680" deep.
 13. Reverse part on magnetic chuck; finish grind second side of slot to .460" dimension to fit mating part.
 14. Remove all sharp edges and submit for inspection and grade.
10. Use parallel to locate work toward center of chuck.
 11. Use a No. 12 dish wheel or reduce the width of a 1/2" straight wheel and undercut the sides. Wheel 23A46-J8VBE is recommended.

Unit No.

Operator's Job Title: Surface Grinder Operator

Project IV

Project Name: Surface Gage

Job No. 2

Job Name: Adjustment Bar

D.O.T. No. 603.280

Drawing Nos. 25.26

Time: 2 hours

Performance Objectives:

Using only the equipment, materials, and operations listed here, the student will be able to produce the piece shown on the drawing in accordance with the time and accuracy requirements specified. After completing this job the student will be able to complete similar jobs with like specifications.

Operations:

1. Wheel dressing
2. Grinding parallel
3. Grinding square
4. Step grinding

Equipment:

Surface grinder	Surface gage
Grinding wheel	Indicator
Diamond wheel dresser	1" micrometer caliper
Grinding vise	Oilstone
Surface plate	

Materials:

SAE 1020, .460" x .480"
x 2.820" piece from mill-
ing machine and heat treat
operations

Selected references:

Krar & Oswald, *Grinding Technology*
McCarthy & Smith, *Machine Tool Technology*; 3d edition

PROCEDURE

TECHNIQUES AND RELATED INFO.

- | | |
|--|---|
| 1. Select part and remove all sharp edges. | |
| 2. Dress grinding wheel sharp and true. | 2. Wheel 32A60-K8VBE is recommended. |
| 3. Locate part in grinding vise, indicate top surface level at each end, and grind off .010". | 3. Set up work in vise on surface plate and check with indicator. |
| 4. Locate part on magnetic chuck on ground surface, and grind opposite side parallel to .440" dimension. | |
| 5. Set up part in grinding vise, level side surface, and grind off .010". | |
| 6. Mount on magnetic chuck and grind opposite side to .460" dimension. | 6. Fit to mating part, if possible. |
| 7. Hold part in grinding vise and grind step to .220" dimension. | 7. Use the grinding vise for securely holding the part. |
| 8. Remove sharp edges and submit for inspection and grade. | |

Unit No.

Operator's Job Title: Surface Grinder Operator

Project V

Project Name: Tool Bit Grinding Gage

Job No. 1

Job Name: Tool Bit Grinding Gage

D.O.T. No. 603.280

Drawing No. 43

Time: 2 hours

Performance Objectives:

Using only the equipment, materials, and operations listed here, the student will be able to produce the piece shown on the drawing in accordance with the time and accuracy requirements specified. After completing this job the student will be able to complete similar jobs with like specifications.

Operations:

1. Wheel dressing
2. Angular wheel dressing
3. Parallel grinding
4. Angular grinding
5. Plunge grinding

Equipment:

Surface grinder Angle wheel dresser
Grinding wheels Grinding vise
Diamond wheel dresser Protractor
6" steel rule

Materials:

Tool steel gage stock
 $\frac{1}{16}$ " x $2\frac{1}{8}$ " x $2\frac{5}{8}$ " from band-
saw and heat treat opera-
tions

Selected references:

Krar & Oswald, *Grinding Technology*
McCarthy & Smith, *Machine Tool Technology*; 3d edition

PROCEDURE

TECHNIQUES AND RELATED INFO.

1. Burr piece.
2. Locate part in grinding vise and grind one of the parallel straight edges to clean up.
3. Reverse part and grind opposite edge parallel.
4. Set up and level the side with the 10° angle and grind to clean up surface.
5. Set up and level the side with the 15° angle and grind to clean up.
6. Replace straight grinding wheel with wheel used for angle grinding, and dress wheel with angle dresser to desired angle.
7. Position part in grinding vise and grind one angular notch to size and location.
8. Redress wheel to second angle and grind second angle to finish size.
9. Remove any sharp edges and submit for inspection and grade.
2. Straight wheel 32A60-K8VBE is recommended. Part should be flat after heat treatment.
4. Use protractor or layout line on part to level edge.
6. Use available type angle dresser following shop practice. Diamond must be on center.

Unit No. Operator's job title: Surface Grinder Operator

Project VI Project Name: Micrometer Boring Head

Job No. 2 Job name: Dovetail Blocks D.O.T. No. 603.280

Drawing Nos. 22, 22.2

Time: 3 hours

Performance Objectives:

Using only the equipment, materials, and operations listed here, the student will be able to produce the piece shown on the drawing in accordance with the time and accuracy requirements specified. After completing this job the student will be able to complete similar jobs with like specifications.

Operations:

1. Wheel dressing
2. Flat grinding
3. Parallel grinding
4. Angular grinding

Equipment:

Surface grinder	Surface gage
Grinding wheel	Indicator
Angle plate	Angle vise
Clamps	Parallels
Surface plate	

Materials:

SAE 1020 piece from milling machine and drill press operations

Selected references:

Krar & Oswald, *Grinding Technology*
McCarthy & Smith, *Machine Tool Technology*; 3d edition

PROCEDURE

TECHNIQUES AND RELATED INFO.

- | | |
|--|---|
| 1. Select part and burr sharp edges. | 1. Use part from milling machine and drill press. |
| 2. Dress grinding wheel sharp. | 2. Straight wheel 32A46-J8VBE is recommended. |
| 3. Set bottom surface on magnetic chuck and grind top surface to clean up. | 4. Hold 1.000" size for assembly to mating parts. |
| 4. Reverse part and grind bottom to 1" dimension. | 5. Use surface plate and indicator on surface gage to level part. |
| 5. Mount part on angle plate and clamp securely with back side leveled for grinding square. | 7. Check for level and angle with indicator on surface plate. |
| 6. Grind back surface to clean up square to top and bottom. | 8. Match angle to assembly requirements. |
| 7. Remove all sharp edges, mount part in angle vise on parallels, and set up 8° angle surface. | |
| 8. Grind 8° angle to clean up entire surface. | |
| 9. Remove all sharp edges and submit for inspection and grade. | |

Unit No. Operator's job title: Surface Grinder Operator
Project VI Project Name: Micrometer Boring Head
Job No. 3 Job name: Dovetail Slide D.O.T. No. 603,280

Drawing Nos. 22, 24

Time: 3 hours

Performance Objectives:

Using only the equipment, materials, and operations listed here, the student will be able to produce the piece shown on the drawing in accordance with the time and accuracy requirements specified. After completing this job the student will be able to complete similar jobs with like specifications.

Operations:

1. Wheel dressing
2. Grinding square
3. Grinding parallel
4. Angular grinding

Equipment:

Surface grinder	Indicator
Grinding wheel	Angle plate
Diamond wheel dresser	Parallel clamps
Grinding vise	Angle vise
Surface plate	Precision square
Surface gage	1" micrometer calipers

Materials:

CRS part from milling machine operation

Selected references:

Krar & Oswald, *Grinding Technology*
McCarthy & Smith, *Machine Tool Technology*; 3d edition

PROCEDURE

TECHNIQUES AND RELATED INFO.

1. Select part and remove all sharp edges.
 2. Dress grinding wheel sharp and true.
 3. Locate part on magnetic chuck on one end and grind other end to clean up tool marks.
 4. Reverse part and grind other end to $1\frac{3}{8}$ " dimension.
 5. Clamp ground end surface to angle plate and level the straight bottom surface with an indicator.
 6. Locate angle plate on magnetic chuck and grind bottom surface square to ends with good finish.
 7. Mount bottom surface on magnetic chuck; grind top parallel to the bottom with good finish, to 1.000" dimension.
 8. Locate part in angle vise set to 8° and grind one angular side. Check angular setting to match mating part.
 9. Reverse part in vise and grind opposite angular side. Hold hole locations on centerline by checking and regrinding opposite side if necessary.
 10. Remove all sharp edges and submit for inspection and grade.
2. Wheel 32A46-J8VBE is recommended.
 3. Block with parallel for secure hold.
 9. Use surface plate and indicator to check hole location on center of part.

Unit No. Operator's Job Title: Surface Grinder Operator

Project VII Project Name: Lathe Center

Job No. 1 Job Name: Lathe Center, Morse Taper D.O.T. No. 603.280

Drawing No. 35

Time: 1 hour

Performance Objectives:

Using only the equipment, materials, and operations listed here, the student will be able to produce the piece shown on the drawing in accordance with the time and accuracy requirements specified. After completing this job the student will be able to complete similar jobs with like specifications.

Operations:

1. Mounting wheel
2. Dressing wheel
3. Cutting off

Equipment:

Surface grinder
Grinding wheel
V-block and clamp
6" steel rule
Square

Materials:

Tool steel, hardened and drawn. Dimensions to be selected from table on drawing. Workpiece from cylindrical grinder operation

Selected references:

Krar & Oswald, *Grinding Technology*
McCarthy & Smith, *Machine Tool Technology*; 3d edition

PROCEDURE

1. Mount cutoff wheel.
2. True and dress wheel.
3. Mount work in V-block and clamp securely.
4. Aline V-block on the magnetic chuck so the axis of the lathe center is parallel with the spindle of the grinder, and the end that is to be cut off is away from the operator.

TECHNIQUES AND RELATED INFO.

1. Recommended wheel is $\frac{1}{8}$ " x 6" dia., No. A60M-6R50. This cutoff wheel is fragile; handle with care.
2. Use extreme caution. Do not stand directly in line with the plane of the wheel.
3. Workpiece has been hardened, thus making it necessary to cut the excess metal off the end by means of a cutoff wheel. The $\frac{1}{4}$ " dia. end of the piece should protrude from the V-block so the wheel guard will miss the V-block and clamp.
4. Check alinement of the V-block by placing one edge of the square against the side of the magnetic chuck and the other edge along the side of the V-block.

PROCEDURE

TECHNIQUES AND RELATED INFO.

5. Position cutoff wheel in relationship to the end of the workpiece.
6. Cut off by using longitudinal table travel.
7. After end has been cut off, submit for inspection and grade.

5. Place the cutoff wheel over the workpiece and measure $\frac{7}{16}$ " from the end of the work to the side of the cutoff wheel.
6. DO NOT USE TRANSVERSE TABLE TRAVEL.
Feed wheel slowly into workpiece.
CAUTION:
Do not stand directly in line with the cutoff wheel. Use coolant to avoid overheating.

Unit No.

Operator's Job Title: Surface Grinder Operator

Project VIII

Project Name: Grinding Vise

Job No. 1

Job Name: Base

D.O.T. No. 603.280

Drawing Nos. 36, 39

Time: 8 hours

Performance Objectives:

Using only the equipment, materials, and operations listed here, the student will be able to produce the piece shown on the drawing in accordance with the time and accuracy requirements specified. After completing this job the student will be able to complete similar jobs with like specifications.

Operations:

1. Wheel dressing
2. Grinding parallel
3. Grinding square
4. Slotting
5. Side grinding

Equipment:

Surface grinder	Parallel clamps
Grinding wheels	Surface plate
Angle plate	Indicator
Grinding vise	1" and 2" micrometers
Precision square	Vernier calipers
Magnetic V-block	Magnetic parallels
Depth micrometer	Diamond wheel dresser

Materials:

SAE 1020 2" x 2" x 4 3/8"
Workpiece from milling, drilling, and heat treat operations

Selected references:

Krar & Oswald, *Grinding Technology*
McCarthy & Smith, *Machine Tool Technology*; 3d edition

PROCEDURE

TECHNIQUES AND RELATED INFO.

1. Remove all burrs.
2. Mount cutoff wheel.
3. Grind $\frac{1}{16}$ " x $\frac{1}{16}$ " clearance slot.
4. Mount straight grinding wheel.
5. Dress and true the wheel.
6. Grind one side of base.

2. Recommended size is $\frac{1}{16}$ " x 6" dia., No. A60-M6R.
3. Locate workpiece on a magnetic V-block, backed up with parallels or angle plate to hold the workpiece securely. Cut the slot first to remove strains in the metal resulting from heat treatment. Use extreme caution with cutoff wheel. It breaks very easily.
4. $\frac{1}{2}$ " x 6" dia., No. 32A60-K8VBE is recommended.
6. Clamp the workpiece in a grinding vise with the bottom surface of the workpiece against the solid jaw. Review basic procedure for grinding hardened parts in order to remove the warp. Grind this first side to clean up.

PROCEDURE

TECHNIQUES AND RELATED INFO:

7. Grind the opposite side of the workpiece.
 8. Grind the bottom surface of the base.
 9. Grind the solid jaw end of the vise base.
 10. Grind the other end of the vise base.
 11. Grind the top surface of the solid jaw.
 12. Grind the bottom inside surface of the base.
 13. Dress the outer side of the wheel.
 14. Grind the inside vertical surface of the solid jaw.
 15. Mount $\frac{1}{4}$ " straight wheel.
 16. True and dress the face and both sides of the wheel.
 17. Grind the bottom and sides of one of the slots on the side of the base.
7. Place the finished ground surface on the magnetic chuck. Grind to clean up. Redress the wheel and remove material from either or both sides as needed to center the .750" slot and to bring the width of the base to 1.970".
 8. Clamp the side of the base to a precision angle plate and indicate to bring both ends level. Grind to clean up.
 9. Clamp the bottom of the vise base to a precision angle plate. Use a solid square to square up the finished side of the vise base. Grind to clean up.
 10. Place the previously ground surface on the magnetic chuck. Grind to drawing specifications. The overall length is 4.360".
 11. Place the base on the magnetic chuck with the low end against the back rail. Grind to the drawing specifications, 1.970".
 12. The workpiece is to remain in the same position as explained in step 11. Grind to drawing specifications, 1.000".
 14. The workpiece is to remain in the same position as stated in step 11. Grind to drawing specifications, .875".
 15. Wheel No. 32A46-K8VBE is recommended.
 16. Width must be less than $\frac{1}{4}$ " when dressed. The sides are to be relieved back $\frac{1}{8}$ " from the face edge of the wheel.
 17. Place the workpiece on its side with the bottom against the back rail of the magnetic chuck. Grind the bottom of the slot to a depth of .130", and the sides to a width of .250". The bottom side of the slot must be .860" from the bottom of the base.

18. Grind the slot on the other side.
 19. Grind the slot in the bottom of the base.
 20. Remove all burrs and sharp edges.
 21. Submit for inspection and grade.
18. Turn the workpiece over and place the bottom against the back rail. Grind to the drawing specifications, .130" deep and .250" wide. The bottom side of the slot must be .860" from the bottom of the base.
 19. Locate the workpiece on magnetic parallels or in a precision grinding vise with the bottom side up. Indicate the side of the workpiece so that it will be parallel to the longitudinal table travel. Grind the bottom of the slot .125" deep. Grind the sides to a width of .750". When grinding the sides, remove enough metal to keep the slot centered.
 20. Use an oilstone.

Unit No. Operator's Job Title: Surface Grinder Operator

Project VIII Project Name: Grinding Vise

Job No. 2 Job Name: Sliding Jaw

D.O.T. No. 603.280

Drawing Nos. 36, 40

Time: hours

Performance Objectives:

Using only the equipment, materials, and operations listed here, the student will be able to produce the piece shown on the drawing in accordance with the time and accuracy requirements specified. After completing this job the student will be able to complete similar jobs with like specifications.

Operations:

1. Wheel dressing
2. Angle wheel dressing
3. Side wheel dressing
4. Parallel grinding
5. Grinding square
6. Side grinding
7. Form grinding

Equipment:

Surface grinder Surface plate
Grinding wheel Surface gage
Cutoff wheel Diamond wheel dresser
Indicator Precision square
Grinding vise 1" and 2" micrometers
Angle plate Angle wheel dresser
Parallel clamps

Materials:

CRS SAE 1020, 1 1/2" x 2" x 1 1/8"
workpiece from milling,
drilling, and heat treat
operations

Selected references:

Krar & Oswald, *Grinding Technology*
McCarthy & Smith, *Machine Tool Technology*, 3d edition

PROCEDURES

TECHNIQUES AND RELATED INFO.

1. Select part and stone to remove all burrs and sharp edges.
 2. Locate part in grinding vise with front surface against solid jaw and side surface up. Check surface with an indicator to level.
 3. Dress grinding wheel sharp and true.
 4. Locate vise on clean magnetic chuck and grind one side to clean up.
 5. Relocate part on magnetic chuck and grind other side parallel to clean up.
 6. Clamp to angle plate on side surface with front surface up and level. Grind to 1.495" dimension with fine finish.
 7. Set up piece face down on magnetic chuck and finish grind back side to 1.480" dimension.
2. Clean surface plate for setting up.
 3. Wheel 32A46-K8VBE is recommended.
 6. Redress wheel when necessary for good finish and accuracy.

PROCEDURE

TECHNIQUES AND RELATED INFO

8. Clamp front or face surface to angle plate with side surface perpendicular, and grind top surface to 1.110" dimension, fine finish.
 9. Relocate front surface on angle plate with one side up and the ground top surface square. Re-grind first side to a fine finish, holding the holes on center of the final dimension.
 10. Set the finished side of the part on magnetic surface and grind the second side to 1.966" dimension, with the through hole and counterbore on center.
 11. Locate top surface on magnetic chuck, with the side surface against the precision ground back rail.
 12. Grind the two .128" flats to attain the 1.095" dimension.
 13. Grind the sliding surface to .125" depth between the two edges, without grinding the sides.
 14. Change grinding wheel to $\frac{1}{16}$ " wide cutoff wheel. Locate part in magnetic V-block and grind the $\frac{1}{16}$ " x $\frac{1}{32}$ " undercut at 45° angle on one side.
 15. Reverse part in V-block and grind undercut on second side.
 16. Dress grinding wheel for side grinding.
 17. Relocate part on magnetic chuck with side surface against back rail and bottom surface up. Grind the inside surface of one edge to .128" dimension.
 18. Reverse part against back rail and finish grind other side to fit the vise base.
 19. Select and mount wheel to grind 90° V-grooves in front face of jaw.
 20. Set up the angle wheel dresser and dress the wheel at a 45° angle on each side to get a 90° included angle.
 21. Locate part on magnetic chuck and finish grind V-grooves to .125" deep.
 22. Relocate part at 90° and grind the vertical V-groove to $\frac{1}{4}$ " wide.
 23. Remove all sharp edges and submit for inspection and grade.
8. Use precision square or indicate with angle plate lying on its side.
 9. Use precision square or indicate with angle plate lying on its side.
 11. Clean the chuck and burr the work.
 14. Use blocks to support part for good hold in magnetic V-block. Dress one side of the cutoff wheel to a 45° angle.
 16. Change to straight wheel or use dish wheel.
 17. CAUTION: Locate carefully to hold necessary parallelism.
 19. Use recommended harder wheel with finer grit for form grinding, if available.
 21. The 90° V-groove formula is depth = $\frac{1}{2}$ width.

7. Set up to grind surface C.
 8. Grind surface C.
 9. Grind surface D.
 10. Grind surface E and the three steps that are parallel to E.
 11. Grind surface F and the three steps that are parallel to F.
 12. Dress the wheel.
 13. Re grind all surfaces.
 14. Remove all sharp edges with a stone and submit the step block for inspection and grade.
7. Clamp surface A to an angle plate with surface C protruding above the top of the plate. Use a solid square to square up surface B.
 8. Grind just enough to clean up.
 9. Place surface C on the magnetic chuck. Grind to clean up.
 10. Place surface B on the magnetic chuck with surface F against the back rail. Grind to clean up.
 11. Place surface A on the magnetic chuck and surface E against the back rail. Grind to clean up.
 12. This will prepare the wheel for finish grinding the workpiece.
 13. Re grind all surfaces to the finish size and finish by repeating steps 3 through 11 as mentioned in the note on page 36. Remove approximately an equal amount from all surfaces until the finish sizes are obtained. When grinding the .375" steps, use gage blocks and a dial indicator to check the distance.

Unit No. Operator's job title: Surface Grinder Operator
 Project X Project Name: 1-2-3 Blocks
 Job No. 1 Job name: 1-2-3 Blocks D.O.T. No. 603,280
 Drawing No. 45 Time: 8 hours

Objectives:

Using the equipment, materials, and operations listed here, the student will be able to produce the piece shown on the drawing in accordance with the time and accuracy requirements specified.

Operations:

1. Wheel dressing
2. Grinding parallel
3. Grinding square
4. Precision inspecting

Equipment:

Surface grinder Surface gage
 Grinding wheel Diamond wheel dresser
 Indicator Parallel clamps
 Angle plate 1", 2", and 3" micrometer calipers
 Grinding vise Gage blocks
 Surface plate Precision square

Materials:

Case hardened steel,
 2 pieces 1.020" x 2.020"
 x 3.020" from milling,
 drilling, and heat treat operations

Selected references:

Krar & Oswald, *Grinding Technology*
 McCarthy & Smith, *Machine Tool Technology*; 3d edition

PROCEDURE

TECHNIQUES AND RELATED INFO.

- | | |
|---|---|
| <ol style="list-style-type: none"> 1. Obtain two blocks and remove all burrs with an oilstone. 2. Dress grinding wheel sharp and true. 3. Locate first block in a grinding vise with the 2" x 3" face above the vise jaws, and level the surface for grinding. 4. Mount vise on magnetic chuck and grind first surface to clean up. 5. Repeat operations 3 and 4 with second block. 6. Place both blocks with their ground surfaces on the magnetic chuck and grind the opposite sides parallel. Check size and leave .002" oversize. 7. Locate first block on a precision angle plate with the 1" x 3" surface projecting above the angle plate, and clamp securely. 8. Mount angle plate on magnetic chuck and grind surface to clean up. | <ol style="list-style-type: none"> 1. Use parts from milling, drilling, and heat treat. 2. No. 32A46-J8VBE is recommended. 3. Check for levelness with the indicator and the vise on a surface plate. Ends must be leveled to the same reading. Check vise for good holding power. 4. Clean chuck and vise base when setting up. Contact highest point with grinding wheel and use .001" cuts. 6. These blocks must be a matching pair. 7. Check and level the surface with an indicator on the surface plate. 8. Contact highest point with wheel and use .001" depth of cut. |
|---|---|

PROCEDURE**TECHNIQUES AND RELATED INFO.**

9. Repeat operations 7 and 8 on second block.
 10. Locate both blocks on the magnetic chuck with the 1" x 3" ground surface on the chuck. Grind parallel to 2.002" dimension.
 11. Lay the precision angle plate on its side. Clamp the first block with the 1" x 2" surface projecting above the top of the angle plate.
 12. Mount angle plate on the magnetic chuck in upright position and grind the 1" x 2" surface to clean up.
 13. Repeat operations 11 and 12 on second block.
 14. Locate both blocks on the magnetic chuck with the 1" x 2" ground surface on the chuck, and grind parallel to 3.002" dimension.
 15. Remove all sharp edges with an oilstone. Check sizes and squareness on the surface plate with gage blocks, an indicator, and a precision square.
 16. Dress grinding wheel carefully, and thoroughly clean the magnetic chuck.
 17. Locate both blocks on 2" x 3" surface and finish grind to 1.0002".
 18. Locate both blocks on 1" x 3" surface and finish grind to 2.0002".
 19. Locate both blocks on 1" x 2" surface and finish grind to 3.0002".
 20. Remove all sharp edges with an oilstone and submit for inspection and grade.
10. Inspect parts for squareness and parallelism on the surface plate. Remove all sharp edges with an oilstone.
 11. Use parallels if needed and check the alinement of the ground edge with an indicator. Adjust until level within .0001".
 14. Block the pieces for support with parallels.
 16. Check for burrs and remove with oilstone if necessary.
 17. Use .0005" or less for depth of cut. The .0002" oversize is left for lapping.
 19. Block pieces for safety.

Unit No. Operator's job title: Surface Grinder Operator

Project XI Project Name: Precision Angle Plate

Job No. 1 Job name: Precision Angle Plate D.O.T. No. 603.280

Drawing No. 46

Time: 6 hours

Performance Objectives:

Using only the equipment, materials, and operations listed here, the student will be able to produce the piece shown on the drawing in accordance with the time and accuracy requirements specified. After completing this job the student will be able to complete similar jobs with like specifications.

Operations:

1. Wheel dressing
2. Grinding square
3. Grinding parallel
4. Precision measuring
5. Burring

Equipment:

Surface grinder	Indicator
Grinding wheel	2" micrometer
Precision angle plate	Gage blocks
Parallel clamps	Mill file or stone
Surface plate	Diamond wheel dresser
Surface gage	

Materials:

Cast iron angle plate
3.020" long, with legs
2.020" wide and .520"
thick from drilling and
milling operations.

Selected references:

Krar & Oswald, *Grinding Technology*
McCarthy & Smith, *Machine Tool Technology*; 3d edition

PROCEDURE

TECHNIQUES AND RELATED INFO.

- | | |
|--|---|
| 1. Select stock and remove burrs. | |
| 2. Mount and dress grinding wheel. | 2. Use shop practice. Wheel recommended is No. 37C36-KVK. |
| 3. Clamp workpiece to precision angle plate on surface plate, with surface A positioned for grinding square to surfaces G and B. | 3. Clean precision angle and surface plate and locate precision angle and workpiece on edge, while clamping work to it. Check for alignment with indicator and mark high point on surface to be ground. |
| 4. Mount the precision angle plate on the magnetic chuck and grind surface A to good finish. | 4. Be sure chuck is clean and free from nicks or burrs. Check magnet for holding power. |
| 5. Relocate the ground surface of the part against the precision angle plate, with surface G up and surface B vertical. | 5. Clean the work and the precision angle plate, wipe off the surface plate, and clamp the workpiece with the ground surface on the surface plate. Check and mark the high point for wheel contact. |
| 6. Mount on magnetic chuck and grind surface G to good finish holding 3.010" dimension. | |

7. Relocate the part on the precision angle plate to grind surface B square to end G and face A.
 8. Grind face to good surface finish.
 9. Remove part and deburr. Locate ground surface G on magnetic chuck and grind surface H parallel, down to .5" dimension.
 10. Burr edges and set up part on face A. Grind surface D to 2.000" dimension.
 11. Burr sharp edges and set up part on face B. Grind surface C to 2.000" dimension.
 12. Locate workpiece against back rail of magnetic chuck and contact the inner surface F. Grind this surface to .500" dimension.
 13. Relocate part to grind surface E to .500" dimension.
 14. Remove all sharp edges and submit for inspection and grade.
7. Set up with precision angle plate on edge, ground face against angle plate, and ground edge on surface plate.
 9. Block part on the magnetic chuck for better holding power. Take a reference cut and check size to hold required accuracy.
 10. Be sure to wipe magnetic chuck clean before setting up work.
 12. Back rail should be ground true, if necessary. Be careful not to run into the vertical surface with the grinding wheel or guard.
 13. Always observe grinding from the right-hand side of the machine to avoid flying particles.

Unit No. Operator's job title: Surface Grinder Operator

Project XII Project Name: V-Block

Job No. 1 Job name: V-Block

D.O.T. No. 603.280

Drawing No. 47

Time: 6 hours

Performance Objectives:

Using only the equipment, materials, and operations listed here, the student will be able to produce the piece shown on the drawing in accordance with the time and accuracy requirements specified. After completing this job the student will be able to complete similar jobs with like specifications.

Operations:

1. Wheel dressing
2. Grinding parallel
3. Grinding square
4. Grinding V-groove

Equipment:

Surface grinder	Surface plate
Grinding wheel	Surface gage
Indicator	Diamond wheel dresser
Grinding vise	Precision square
Angle plate	1", 2", and 4" micrometer
Parallel clamps	Grinding fixture
5" sine bar	Gage blocks

Materials:

SAE 1020, $1\frac{29}{32}$ " x $1\frac{7}{8}$ "
x $3\frac{21}{32}$ " workpiece from
milling, drilling, and
heat treat operations

Selected references:

Krar & Oswald, *Grinding Technology*
McCarthy & Smith, *Machine Tool Technology*; 3d edition

PROCEDURE

TECHNIQUES AND RELATED INFO.

1. Select part and remove all sharp edges and burrs with a stone.
2. Set up in grinding vise with surface A up, and indicate level at each end.
3. Dress grinding wheel sharp and true.
4. Locate vise on magnetic chuck and grind top surface A to clean up.
5. Locate ground base A on magnetic chuck and grind top surface B to $1\frac{27}{32}$ " dimension.
6. With workpiece on same location grind surface C to $\frac{15}{32}$ " dimension.
7. Locate base A against angle plate and clamp securely. Level side D and grind to 1.890" leaving .015" over the $1\frac{7}{8}$ ".
8. Locate ground side D on magnetic chuck and grind surface E parallel and down to $1\frac{7}{8}$ " dimension.
9. Clamp base A to angle plate with end F up and sides square. Grind end F to 3.640" dimension.
10. Locate on ground end F and grind end G to $3\frac{5}{8}$ " dimension. Finish grind surface H to the 2" dimension on same setup.
2. Clean surface plate every time; check part for warpage.
3. No. 32A46-J8VBE is recommended. Clean magnetic chuck after dressing wheel.
7. Dress grinding wheel as needed.
10. Back up part with parallels on the magnetic chuck.

11. Locate part in V-block grinding fixture and grind low side J of V-groove to clean up. Record the number on downfeed handwheel.
 12. Locate on opposite side in fixture and grind side K of V-groove to the marked number on downfeed handwheel.
 13. Check both sides of V-groove with indicator on surface plate. Re grind, if necessary, to exact center location.
 14. Locate part on end in fixture, or bolt to angle plate, and set with a sine bar. Grind side L of small V-groove; reverse part and grind side M.
 15. Check for center location and regrind required amount to bring V-groove on center.
 16. Remove all sharp edges and submit for inspection and grade.
11. With block in grinding fixture on surface plate, indicate both sides of V-groove to find low side.
 13. Bottom and sides must be square and parallel to develop a correctly ground V-groove.

Unit No. Operator's Job Title: Surface Grinder Operator

Project XII Project Name: V-Block

Job No. 2 Job Name: Clamp D.O.T. No. 603.2807

Drawing No. 48 Time: 7 hours

Performance Objectives:

Using only the equipment, materials, and operations listed here, the student will be able to produce the piece shown on the drawing in accordance with the time and accuracy requirements specified. After completing this job the student will be able to complete similar jobs with like specifications.

Equipment:

Surface grinder High speed spindle attachment
Grinding wheels 1" and 2" micrometer calipers
Vise Telescoping gages, 1" to
Square $1\frac{1}{2}$ " capacity
 $\frac{1}{4}$ " x $\frac{1}{2}$ " parallels Universal bevel protractor

Operations:

1. Attaching high speed spindle attachment
2. Wheel mounting
3. Wheel dressing
4. Flat surface grinding
5. Parallel surface grinding
6. Angle grinding
7. Side grinding
8. Step grinding
9. Internal grinding

Materials:

SAE 1020 workpiece from lathe, milling, drilling, and band sawing operations

Selected references:

Krar & Oswald, *Grinding Technology*
McCarthy & Smith, *Machine Tool Technology*; 3d edition

PROCEDURE

TECHNIQUES AND RELATED INFO.

1. Remove all burrs.
2. Grind surface A by placing in vise on parallels. Grind to clean up.
3. Grind side B by placing surface A on magnet.
4. Remove burrs.
5. Grind surface X.
2. Recommended wheel is 23A46-J8VBE. Place $1\frac{1}{16}$ " opening against solid jaw of vise. Grind sides so as to keep boss centrally located. Surface finish on all surfaces is to be between 8 and 16 microinches.
3. Use paper between surface A and the magnet to avoid scratching the finish on the workpiece.
5. Place finished surfaces A and B against vise jaws. Square piece from surface D, on which the boss is located, since this surface has already been finished in the lathe. Place paper between workpiece and vise jaws. Grind equally from both sides so as to keep the boss centrally located.

6. Grind surface Y by turning piece over and placing surface X on magnet.
7. Grind surface E.
8. Grind surface F.
9. Remove burrs.
10. Grind surface C to obtain the $1\frac{5}{8}$ " dimension.
11. Mount the high-speed spindle attachment and mounted wheel.
12. Grind side G of the $1\frac{5}{16}$ " opening. Surface should be tangent to bored hole at the time that the $\frac{3}{16}$ " dimension is reached.
13. Grind side J of the $1\frac{1}{16}$ " opening until a $\frac{1}{8}$ " step is obtained.
14. Grind side H of the $1\frac{5}{16}$ " opening until correct size is reached.
15. Grind side K of the $1\frac{1}{16}$ " opening.
16. Side grind inside of both of the $\frac{1}{8}$ " steps until the $1\frac{1}{16}$ " opening is $\frac{3}{16}$ " thick.
17. Remove burrs and all sharp edges.
18. Submit for inspection and grade.
7. Place piece in vise as in step 5 but tilted to a 45° angle. Check angle setting by placing the protractor against the base of the vise and surface X. Grind surface until $\frac{7}{16}$ " distance is obtained as shown on the drawing.
8. Repeat the above procedure.
9. Use mill file.
10. Place in vise with surfaces A and B against the jaws and surface C protruding above the vise jaws. Square the workpiece from side X.
11. $1" \times 1\frac{1}{4}"$, No. 23A46-MJVBE is recommended. Dress wheel.
12. Place workpiece in vise with the surfaces A and B against vise jaws and the open end protruding from the side of the vise at least 1". Place $\frac{3}{8}"$ block at the opposite end of vise so as to keep jaws parallel.
13. Workpiece is to remain in the same position as in step 12.
14. Workpiece is to remain in the same position as in step 12.
16. Dress inside face and undercut the side of the mounted wheel.

Unit No.

Operator's Job Title: Surface Grinder Operator

Project XIII

Project Name: Parallels

Job No. 1

Job Name: Parallels

D.O.T. No. 603.280

Drawing No. 50

Time: 6 hours

Performance Objectives:

Using only the equipment, materials, and operations listed here, the student will be able to produce the piece shown on the drawing in accordance with the time and accuracy requirements specified. After completing this job the student will be able to complete similar jobs with like specifications.

Operations:

1. Wheel dressing
2. Grinding parallel
3. Grinding square

Equipment:

Surface grinder	Surface plate
Grinding wheel	Surface gage
Grinding vise	Indicator
Angle plate	1" micrometer calipers
Parallel clamps	Auxiliary top plate

Materials:

CRS SAE 1020, $\frac{17}{32}$ " x $\frac{25}{32}$ " x $6\frac{1}{32}$ " workpiece from milling, drilling, and heat treat operations, 2 pieces require

Selected references:

Krar & Oswald, *Grinding Technology*
McCarthy & Smith, *Machine Tool Technology*; 3d edition

PROCEDURE

1. Obtain parts, remove burrs, and check for warp.
2. Dress grinding wheel sharp and true.
3. Locate first piece in grinding vise with $\frac{3}{4}$ " side up, and clamp level.
4. Set up grinding vise on magnetic chuck. Contact highest point with grinding wheel and grind surface to clean up.
5. Repeat setup and grind second part to clean up one side.
6. Locate ground surfaces of both parts on magnetic chuck and grind other sides to clean up parallel.
7. Check the depth of the $\frac{1}{8}$ " x $\frac{3}{8}$ " cut on each side of both pieces. Rough grind to clean up, keeping $\frac{1}{4}$ " web centrally located.

TECHNIQUES AND RELATED INFO.

1. Parallels should always be ground in pairs.
2. No. 32A60-J8VBE recommended.
3. Level the ends of the part to the same indicator reading. Check again after tightening vise jaws. Warp in workpiece should be compensated for by shimming with paper or shim stock to avoid distortion.
4. Rough grind all surfaces, to relieve strains and eliminate warp.
7. **CAUTION:** One part may have more warp than the other. Grind finish sizes together.

8. Locate first piece on precision angle plate and clamp securely with one edge $\frac{1}{16}$ " above top of plate. Level ends with an indicator and grind to clean up.
9. Repeat operation 8 on second piece.
10. Locate both parts on magnetic chuck and grind opposite edges to clean up.
11. Check the $\frac{3}{8}$ " wide undercut and grind the parts to clean up, keeping the $\frac{3}{8}$ " wide undercut centrally located.
12. Set up and dress $\frac{3}{8}$ " wide wheel.
13. Locate both parts against back rail of magnetic chuck end to end, and grind $\frac{3}{8}$ " undercut to clean up.
14. Turn parts over and grind other side of slot to clean up.
15. Grind one end to clean up.
16. Grind other end to 6" dimension.
17. Finish grind all four main surfaces on each piece by placing on an auxiliary top plate.
18. Remove all sharp edges with a stone and submit for inspection and grade.
14. Remove burrs before placing on magnetic chuck.
15. Clamp on end to an angle plate. Check with a square to make sure that the workpiece is vertical.
16. Turn piece end for end and check with square to make sure workpiece is vertical.
17. The auxiliary top plate must be ground in place before placing workpieces on it. A dressed wheel and light grinding cuts are essential in finish grinding parallels, to avoid overheating, which would result in more warpage.

Unit No.

Operator's Job Title: Surface Grinder Operator

Project XIV

Project Name: Sharpen Thread Tap

Job No. 1

Job Name: Sharpen Thread Tap

D.O.T. No. 603.280

Drawing No. 51

Time: 3 hours

Performance Objectives:

Using only the equipment, materials, and operations listed here, the student will be able to correctly sharpen the thread tap shown on the drawing in accordance with the time and accuracy requirements specified. After completing this job the student will be able to complete similar jobs with like specifications.

Operations:

1. Wheel mounting
2. Dressing a form wheel
3. Form grinding
4. Cutter grinding

Equipment:

Surface grinder
Grinding wheel
Index head and tail center
Radius dresser
 $\frac{3}{4}$ " dog
 $\frac{5}{16}$ " radius gage

Material:

$\frac{3}{4}$ " high-speed steel thread tap

Selected references:

Krar & Oswald, *Grinding Technology*
McCarthy & Smith, *Machine Tool Technology*; 3d edition

PROCEDURE

TECHNIQUES AND RELATED INFO.

- | | |
|--|--|
| <ol style="list-style-type: none">1. Mount straight wheel.2. True operator's side of the wheel.3. Dress wheel to a $\frac{3}{16}$" convex radius.4. Mount index head and center. | <ol style="list-style-type: none">1. $\frac{3}{8}$" x 4" wheel 32A46-L7VG is recommended.2. The operator's side of the wheel is trued because the cutting edges of a right-hand tap will be against this side of the wheel.3. Make sure that the diamond is set on center so as to obtain the required $\frac{3}{16}$" radius that corresponds to the setting of the radius dresser and to the radius that forms the flute in the $\frac{3}{4}$" tap. Make sure that the radius dressed on the wheel comes tangent to the operator's side of the wheel.4. Make sure that the table and bottom of the index head and tail center are clean. Mount index head on right end of the table and secure with T-bolts. |
|--|--|

5. Place tap between centers with dog attached to shank.

6. Aline tap and grinding wheel.

7. Grind flutes.

8. Submit for inspection and grade.

5. Make sure that the dog is secure in the slot in the index head. (Taps without center holes are to be held in collets.)

6. Rotate index head spindle and tap so the radius on the wheel will fall in place in the flute of the tap, on the operator side of the wheel. This will show that the side of the wheel is a considerable distance off-center from the index head, thus resulting in the same angle that was originally on the tap.

7. Set longitudinal traverse stops before grinding.

CAUTION: Be sure of sufficient clearance between the wheel guard and the dog at the end of the traverse.

For each cut along the face of the tap teeth, move the table away from the operator no more than .0005" per cut. After each .0005" cut, index for the next flute. After each complete cycle or revolution, move the table away from the operator another .0005" for the next cut on each flute. Repeat until tap is sharp.

Use coolant to avoid burning tap. Redress the wheel as needed to maintain a free cutting wheel and to obtain a surface finish of 8 to 16 microinches.

Unit No. Operator's Job Title: Surface Grinder Operator

Project XV Project Name: Sharpen Thread Die

Job No. 1 Job Name: Sharpen Thread Die D.O.T. No. 603.280

Drawing No. 52 Time: 2½ hours

Performance Objectives:

Using only the equipment, materials, and operations listed here, the student will be able to correctly sharpen the thread die shown on the drawing in accordance with the time and accuracy requirements specified. After completing this job the student will be able to complete similar jobs with like specifications.

Operations:

1. Wheel mounting
2. Wheel dressing
3. Form grinding
4. Cutter grinding

Equipment:

Surface grinder
Grinding wheel
High-speed spindle attachment
Diamond wheel dresser
Index head and chuck

Square
Surface gage

Material:

$\frac{5}{8}$ " thread die (round, split)

Selected references:

Krar & Oswald, *Grinding Technology*
McCarthy & Smith, *Machine Tool Technology*; 3d edition

PROCEDURE	TECHNIQUES AND RELATED INFO.
1. Mount high-speed attachment and wheel.	1. $\frac{3}{8}$ " dia. wheel, 23A46-MSVBE is recommended.
2. Dress wheel.	2. Dress wheel until the diameter is slightly smaller than the circular opening that forms the cutting edge of the die. (For example, dress the wheel to $\frac{5}{16}$ " dia. for an $\frac{11}{32}$ " die opening.)
3. Place the thread die in the chuck which is mounted on the index head.	3. The lead face of the die should be facing out.
4. Aline the index head on the magnetic chuck.	4. Square the edge of the index head with the edge of the magnetic chuck so that the axis of the die is parallel with the axis of the grinding wheel.

5. Aline thread die.

5. Rotate the index head spindle so two opposite cutting edges of the die are horizontal.

Then, while facing the machine, place the grinding wheel in the left-hand flute in a way that will grind the hook at the cutting edge. Make a cut by lowering the wheel. (See the drawing.)

6. Grind flutes.

6. After a pass through the flutes, index to the next flute and repeat. (Make the passes through the flutes by moving the table transversely.)

Repeat until each cutting edge is sharp, removing the same amount of material from each flute. The finish is to be approximately 16 microinches.

7. Remove the die and submit it for inspection and grade.

Unit No. Operator's Job Title: Surface Grinder Operator

Project XVI Project Name: Grind a Form Tool

Job No. 1 Job Name: Grind Form Tool for Screwdriver Handle D.O.T. No. 603.280

Drawing No. 53 Time: 2 hours

Performance Objectives:

Using only the equipment, materials, and operations listed here, the student will be able to correctly form the tool shown on the drawing in accordance with the time and accuracy requirements specified. After completing this job the student will be able to complete similar jobs with like specifications.

Operations:

1. Wheel mounting
2. Flat surface grinding
3. Form dressing
4. Cutter grinding

Equipment:

Surface grinder	Radius gage ($\frac{17}{32}$ ")
Grinding wheel	Surface plate
Angle plate	Universal bevel protractor
Parallel clamp	6" steel rule
Diamond radius dresser	Bench grinder

Material:

$\frac{1}{2}$ " high-speed tool bit

Selected references:

Krar & Oswald, *Grinding Technology*
McCarthy & Smith, *Machine Tool Technology*; 3d edition

PROCEDURE

TECHNIQUES AND RELATED INFO.

- | | |
|---|--|
| 1. Mount wheel. | 1. $\frac{1}{2}$ " x 7", No. 32A60-K8VBE wheel is recommended. |
| 2. True wheel. | |
| 3. Surface grind top flat of tool bit. | |
| 4. True operator side of wheel. | |
| 5. Dress the $\frac{17}{32}$ " concave radius on the wheel. | 5. With the dresser set for a $\frac{17}{32}$ " radius, set swivel on zero and the centerline of the diamond in line with the trued side of the wheel. Move the table away from the operator $\frac{19}{64}$ " as shown on the drawing, which will locate the diamond for dressing the radius. Dress the wheel until the radius meets the trued side of the wheel. |
| 6. Rough grind the radius. | 6. By rough grinding the radius on a bench grinder freehand, you will not need to redress the wheel for a finish grind. Check radius with radius gage. |

7. Set up tool bit on angle plate.

8. Aline angle plate and workpiece on the magnetic chuck.

9. Form-grind the radius.

10. Remove tool bit and submit for inspection and grade.

7. With the upright face of the angle plate toward you, clamp and adjust the tool bit on this face so the end to be finish-formed is protruding above the top surface of the angle plate. The flat ground surface should now be on the right and should form an angle of 75° between the ground face and the surface plate on which the angle plate is resting.

8. Place the back edge of the angle plate against the back rail on the magnetic chuck. Aline the edge of the tool bit with the trued side of the grinding wheel.

9. Use flood of coolant to avoid burning the tool bit.

Grind by moving the table back and forth longitudinally and at the same time lower the wheel approximately .001" per pass until the full radius has been obtained. Check with radius gage. Finish should be within 16 microinches.

Unit No.

Operator's Job Title: Surface Grinder Operator

Project XVII

Project Name: Grinding Fixture for Thread Tool

Job No. 1

Job Name: Grinding Fixture for Thread Tool

D.O.T. No. 603.280

Drawing Nos. 54, 55

Time: 10 hours

Performance Objectives:

Using only the equipment, materials, and operations listed here, the student will be able to grind the grinding fixture shown on the drawing in accordance with the time and accuracy requirements specified. After completing this job the student will be able to complete similar jobs with like specifications.

Operations:

1. Wheel dressing
2. Parallel grinding
3. Side grinding
4. Angular grinding

Equipment:

Surface grinder	Sine bar
Grinding wheels	Indicator
Diamond wheel dresser	Surface plate
Parallel clamps	Gage blocks
Square	Surface gage
Steel rule	Tilting vise

Materials:

SAE 1020, $1\frac{1}{2}$ " x $1\frac{21}{32}$ " x $2\frac{13}{32}$ " workpiece from the milling, drilling, and heat treat operations.

Selected references:

Krar & Oswald, *Grinding Technology*
McCarthy & Smith, *Machine Tool Technology*; 3d edition

PROCEDURE

TECHNIQUES AND RELATED INFO.

- | | |
|--|--|
| 1. Mount straight wheel. | 1. $\frac{1}{2}$ " x 7" No. 23A46-MSVBE is recommended. |
| 2. Dress wheel. | |
| 3. Grind surface E to clean up. | 3. Place on magnetic chuck. Surface finish on all surfaces to be no coarser than 16 microinches. |
| 4. Grind surface F. | 4. To 1,000" as specified on drawing. |
| 5. Mount wheel of $\frac{5}{16}$ " thickness. | 5. $\frac{5}{16}$ " x 7" wheel 23A46-MSVBE is recommended. |
| 6. Dress face and sides of wheel. | |
| 7. Aline $\frac{5}{16}$ " slot parallel with longitudinal table travel. | 7. Aline by indicating the side of the slot. |
| 8. Grind the bottom of the $\frac{5}{16}$ " slot. | |
| 9. Grind sides of slot. | 9. Keep slot centered with relation to the bolt hole. Make slot $\frac{5}{16}$ " wide. |
| 10. Redress sides of the $\frac{5}{16}$ " wheel to fit in the $\frac{1}{4}$ " slot on the block. | |

11. Align the $\frac{1}{4}$ " slot.
12. Grind the bottom of the $\frac{1}{4}$ " slot.
13. Grind the sides of the slot.
14. Remount $\frac{1}{2}$ " wheel.
15. Dress and true the wheel.
16. Set up the fixture to grind surface A.
17. Grind surface A.
18. Set up the fixture to grind surface B.
11. Place the fixture with the $\frac{5}{16}$ " slot down, surface E on the magnet, and a ground $\frac{5}{16}$ " tool bit protruding from the fixture. Indicate the side of the tool bit so the slot will be parallel with the longitudinal table movement. (The $\frac{1}{4}$ " slot, when ground, will be parallel with the $\frac{5}{16}$ " slot.)
12. Make its depth $\frac{1}{4}$ ".
13. Make its width $\frac{1}{4}$ ". Grind from each side in turn to keep this slot centered with relation to the $\frac{5}{16}$ " slot. Use a square on the magnet and against a $\frac{5}{16}$ " tool bit to check the center location of the $\frac{1}{4}$ " slot.
16. Place the fixture in the tilting vise with surface F against the solid jaw of the vise. Tilt the fixture in the vise so the $\frac{5}{16}$ " slot makes a 30° angle with the base of the surface plate. Use a sine bar to obtain the 30° angle.
- Tilt the tilting vise $7^\circ 30'$ by lowering the side of the fixture containing the $\frac{5}{16}$ " slot.
17. Grind enough to keep the slot centered.
18. Place the fixture in the tilting vise with surface F against the solid jaw.
- Tilt the fixture in the tilt vise so the $\frac{5}{16}$ " slot is at 30° angle from the surface plate on which the vise is resting. Tilt the vise $7^\circ 30'$ by lowering that side of the fixture containing the $\frac{5}{16}$ " slot.

19. Grind surface B.
20. Set up the fixture to grind surface C.
21. Grind surface C.
22. Set up fixture to grind surface D.
23. Grind surface D.
24. Remove all sharp edges and submit for inspection and grade.
19. Grind enough to keep the slot centered.
20. Place the fixture in the tilt vise with surface E against the solid jaw.
- Tilt the fixture in the tilt vise so the $\frac{1}{4}$ " slot makes a 30° angle with the surface plate. Tilt the vise 10° by lowering the side of the fixture containing the $\frac{1}{4}$ " slot.
21. Grind enough to keep slot centered.
22. Place the fixture in the tilt vise with surface E against the solid jaw. Tilt the block in the vise so the $\frac{1}{4}$ " slot makes 30° angle with the surface plate. Use sine bar to obtain the 30° angle.
- Tilt the vise 10° by lowering the side of the fixture containing the $\frac{1}{4}$ " slot.
23. Grind enough to keep the slot centered.

Bibliography

- Anderson, James & Tatro, Earl E. *Shop theory*; 5th ed. New York, N.Y. McGraw-Hill. 1968.
- Krar, Stephen & Oswald, William. *Grinding technology*. Albany, N.Y. Delmar Publishers. 1973.
- McCarthy, Willard J. & Smith, Robert E. *Machine tool technology*; 3d ed. Bloomington, Ill. McKnight & McKnight. 1968. (Order from Taplinger Publishing Co., 200 Park Ave., S., New York, N.Y. 10003.)
- Walker, John R. *Machining fundamentals*. South Holland, Ill. Goodheart-Willcox Co. 1969.
- Wilkie Brothers Foundation. *Precision surface grinding*. Albany, N.Y. Delmar Publishers. 1964. (This book is out of print but is still useful. It can be found in some libraries.)

Drawings for Shop Projects

69

58

PARTS LIST

NO.	NAME	MATL.	REQD.
1	GRADUATED DIAL	CRS	1
2	PLATE	CRS	1
3	SHANK	CRS	1
4	DOVETAIL BLOCKS	CRS	2
5	DOVETAIL SLIDE	CRS	1
6	DOWEL PIN $\frac{3}{16}$ DIA. x $\frac{1}{4}$	CRS	4
7	HEX. HD. CAP. SCR. $\frac{5}{16}$ -18 UNC	CRS	2
8	STOP PIN	CRS	1

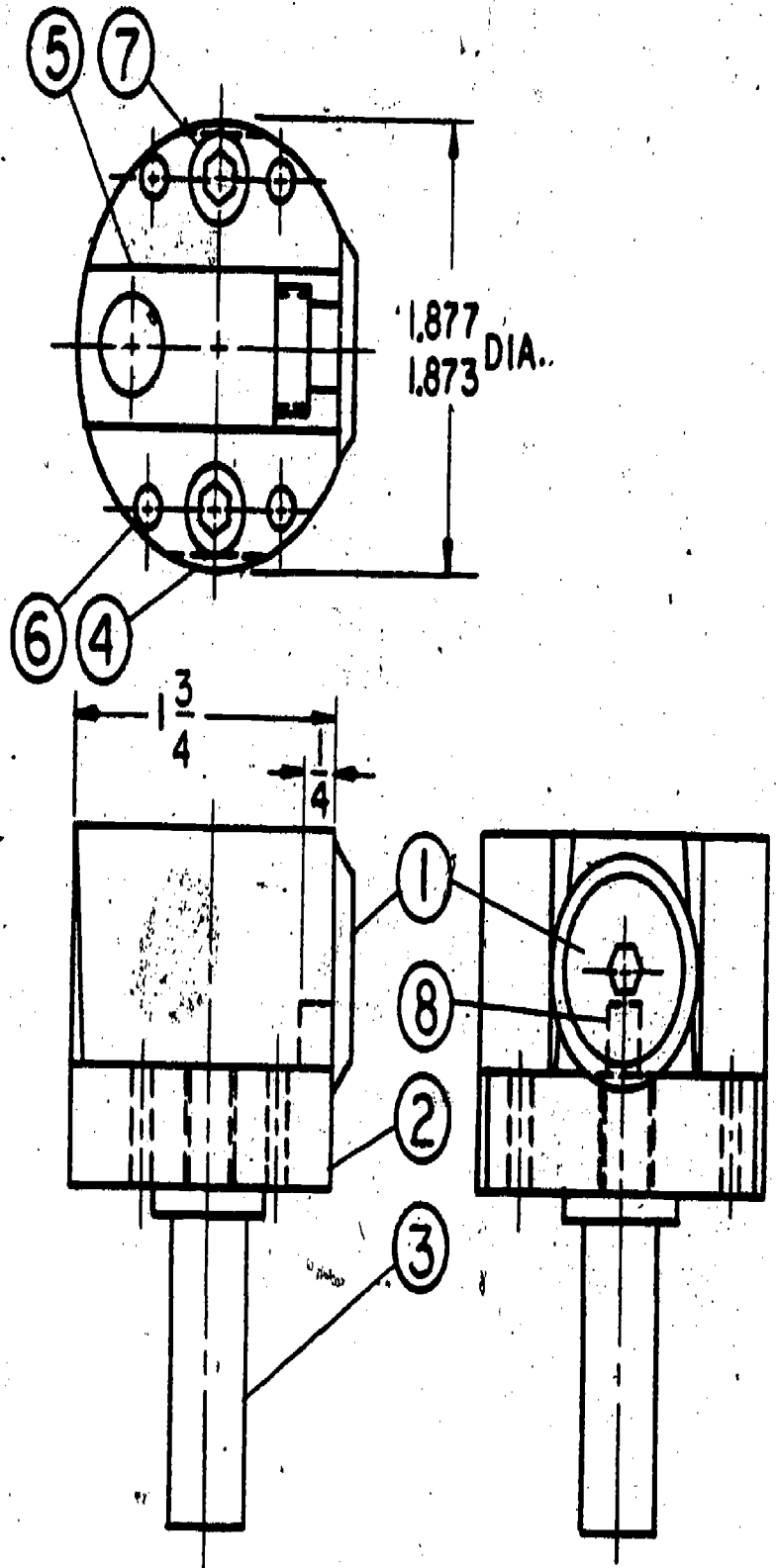

- NOTES:**
1. PARTS 2 AND 4 ARE MILLING MACHINE PROJECTS.
 2. PARTS 6 AND 7 ARE PURCHASED.
 3. PARTS 2, 4 AND 5 ARE ASSEMBLED TO A 2" SQ. AND THEN MACHINED ROUND.

DRAWN BY: E.F. S.

SCALE: —

MICROMETER BORING HEAD ASSEMBLY

DWG. NO. 22

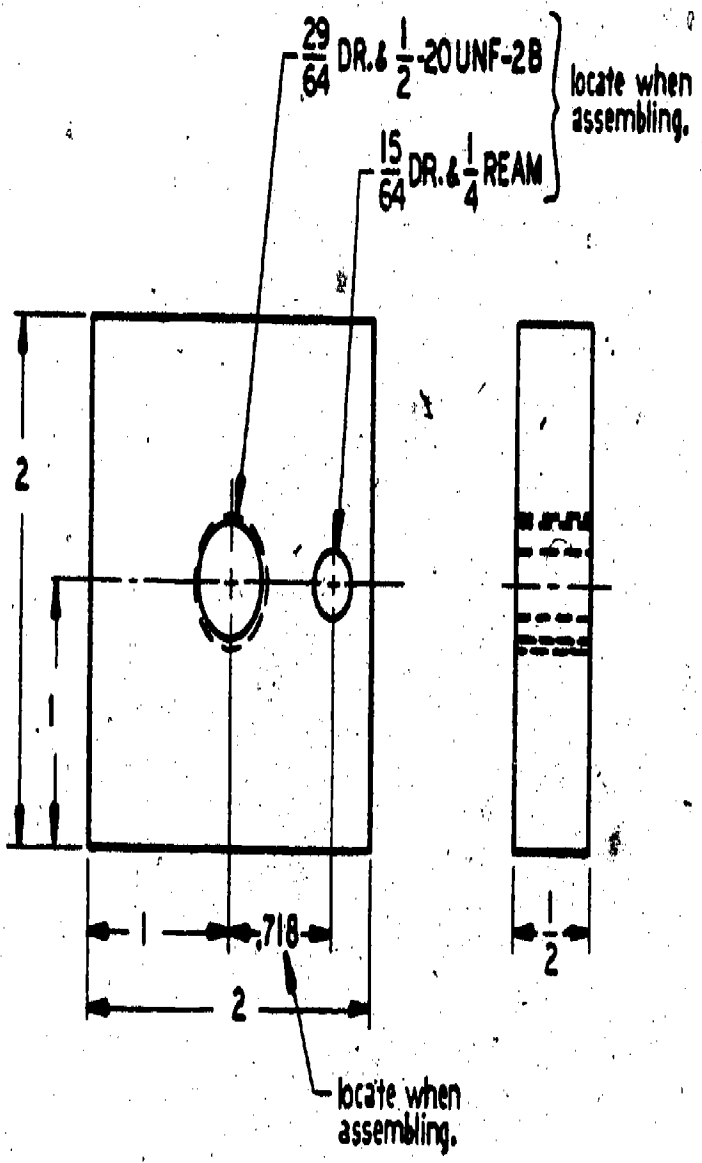

(2) MATL. CRS
 FAO

TOLERANCES:
 (UNLESS OTHERWISE SPECIFIED)
 ±.005 DECIMAL
 ± $\frac{1}{64}$ FRACTIONAL
 ± $\frac{1}{2}^\circ$ ANGULAR

DRAW BY: E.F.S.

MICROMETER BORING HEAD
 PLATE

DWG. NO. 22.1

this area removed after
all machining

$\frac{21}{64}$ DRILL, .437 CORE x .343 DP.
2 HOLES

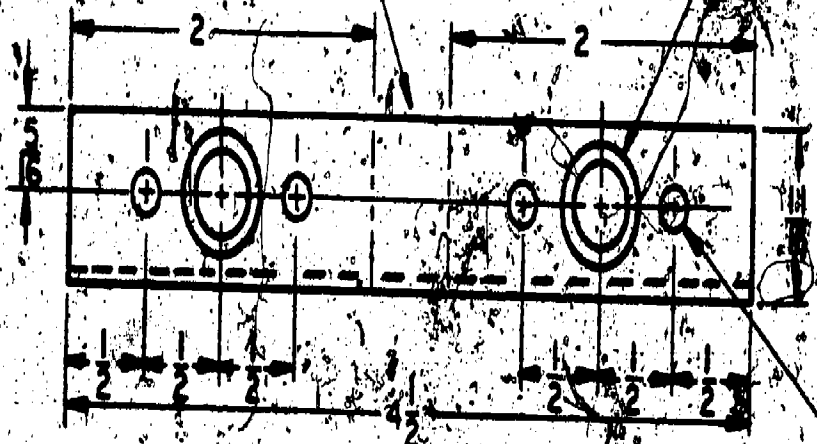

$\frac{11}{64}$ DRILL, $\frac{7}{32}$ CSK.
($\frac{3}{16}$ REAM AT ASSY)
4 HOLES

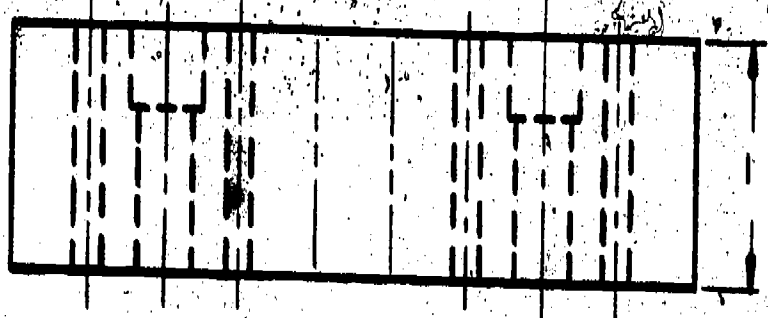

8° angle to be matched
with angle of slide

4 NATL. CRS
FAO
2 REQD.

TOLERANCES:
(UNLESS OTHERWISE SPECIFIED)

- ± .005 DECIMAL
- ± $\frac{1}{64}$ FRACTIONAL
- ± $\frac{1}{2}^\circ$ ANGULAR

DRAWN BY: E.F.S.
SCALE: —

MICROMETER BORING HEAD
DOVETAIL BLOCKS

RWG. NO. 22.2

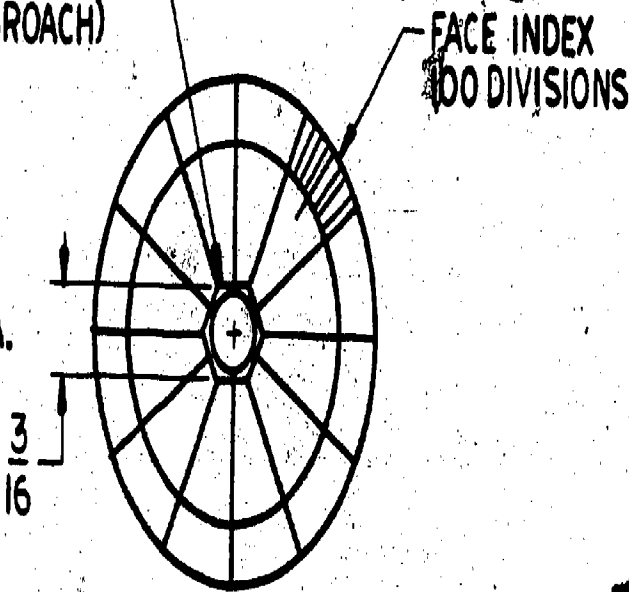
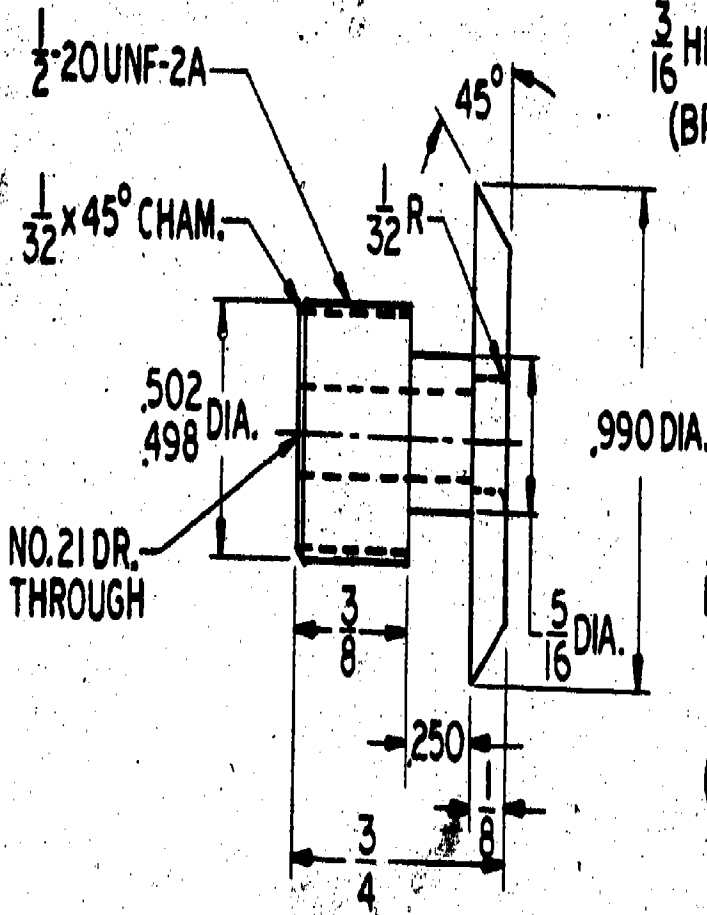

① DIAL
MATL. CRS
CASE HARDEN

TOLERANCES:
(UNLESS OTHERWISE SPECIFIED)
±.005 ON DECIMAL DIMENSIONS
± 1/64 ON FRACTIONAL DIMENSIONS
± 1° ON ANGULAR DIMENSIONS

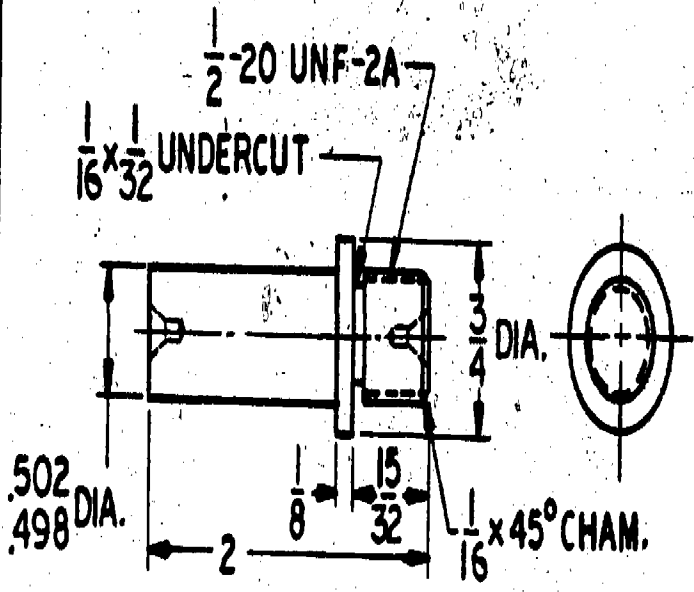

③ SHANK
MATL. CRS
FAO

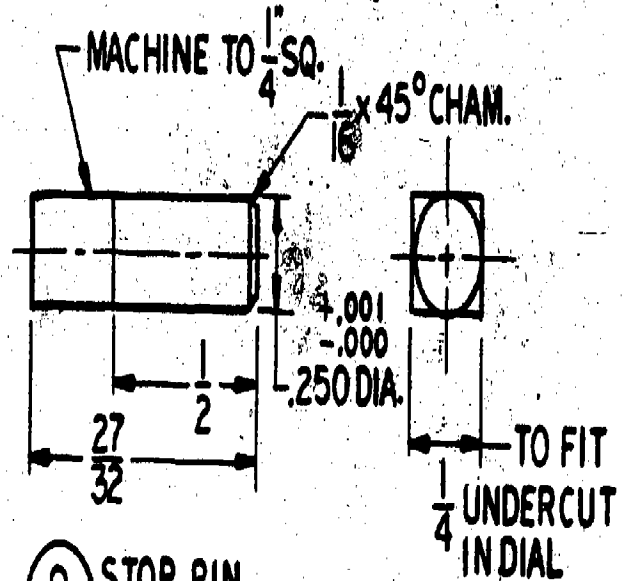

⑧ STOP PIN
MATL. DR. ROD HARDENED
FAO

DRAWN BY: E.F.S.

SCALE: —

MICROMETER BORING HEAD
DIAL, SHANK, AND STOP PIN

DWG. NO. 23

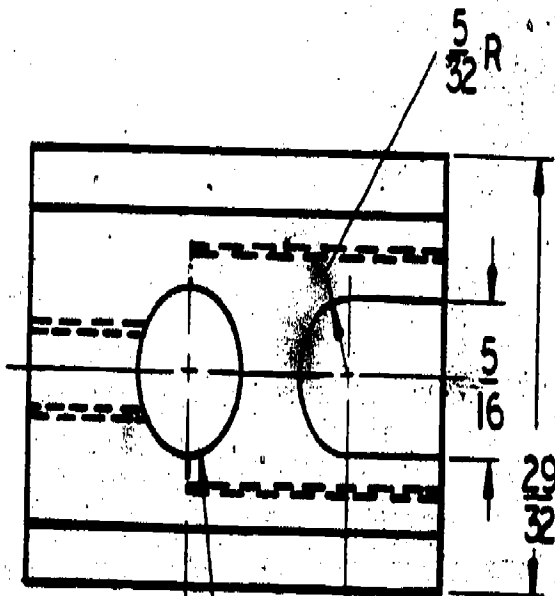

TOLERANCES:
 (UNLESS OTHERWISE SPECIFIED)
 ±.005 ON DECIMAL DIMENSIONS
 ± 1/64 ON FRACTIONAL DIMENSIONS
 ± 1° ON ANGULAR DIMENSIONS

11/32 DRILL, 375 REAM x 7/8 DP.
 LOCATE AND REAM
 AFTER ASSEMBLY

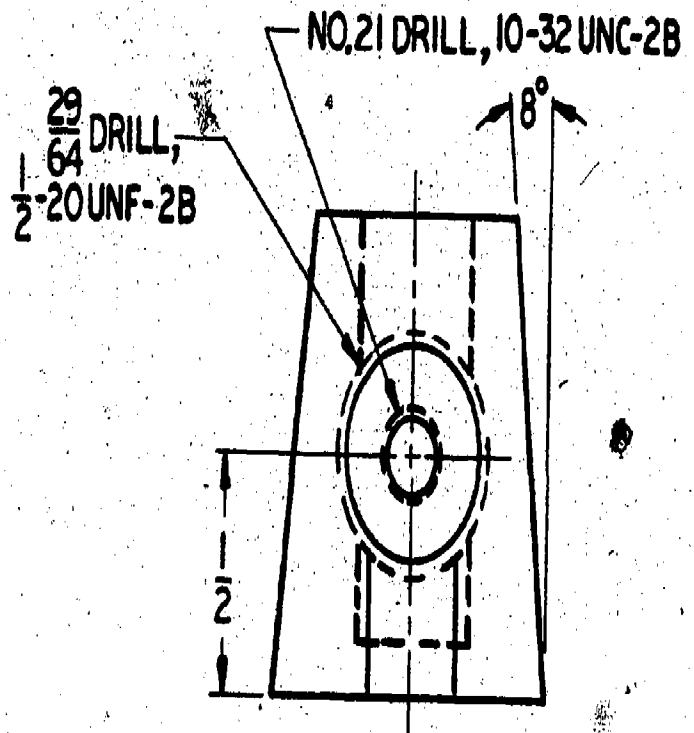
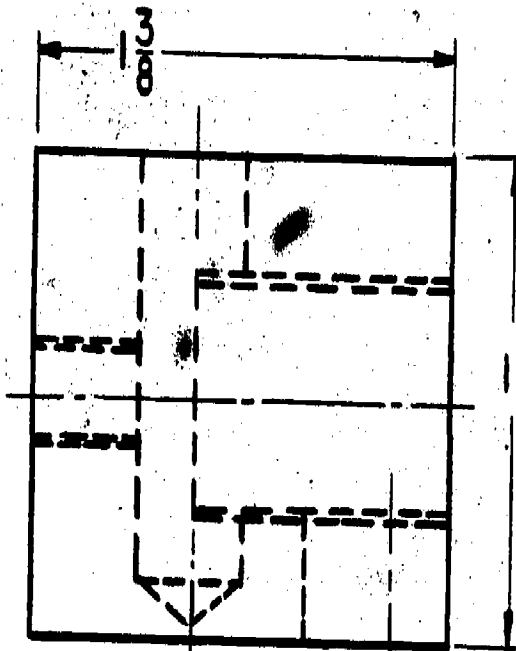
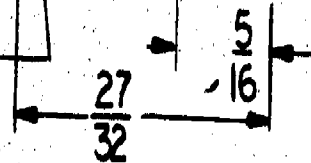

5 DOVETAIL SLIDE
 MATL. CRS
 FAO

DRAWN BY: E.F.S.

SCALE: —

MICROMETER BORING HEAD
 DOVETAIL SLIDE

DWG. NO. 24

PARTS LIST

NO.	NAME	MATL.	REQD.
1	BASE $\frac{15}{16} \times 1 \times 2 \frac{7}{8}$	CRS	1
2	ADJUSTMENT BAR	CRS	1
3	SCRIBER PT. $\frac{3}{8} \text{D} \times 2 \frac{5}{8}$	DR	1
4	DOWEL PIN $\frac{5}{16} \text{D} \times 1$	CRS	1
5	ADJ. SCREW	CRS	1
6	SPRING TO SUIT	STD.	1

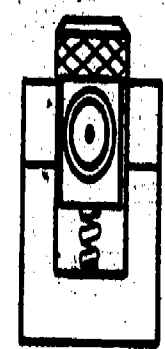
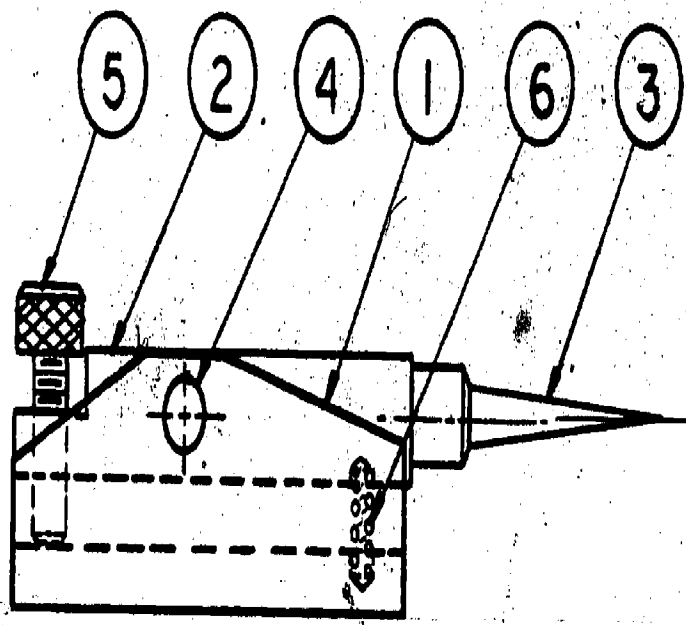
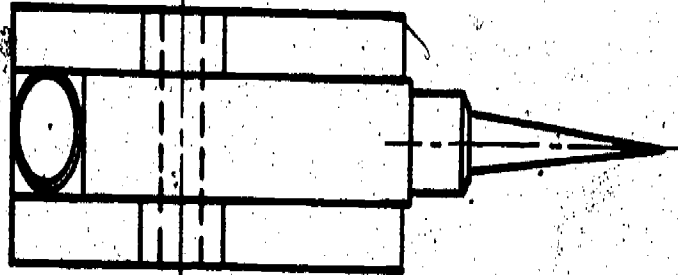

DRAWN BY: E.F.S.

SURFACE GAGE
ASSEMBLY

DWG. NO. 25

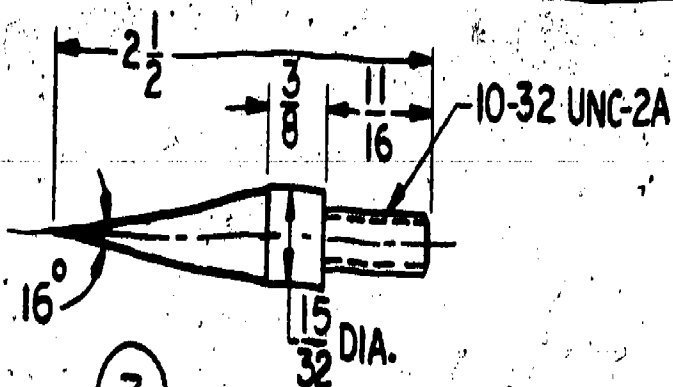

3 SCRIBER POINT
MATL. DR. ROD
1 REQD.
HARDEN & TEMPER

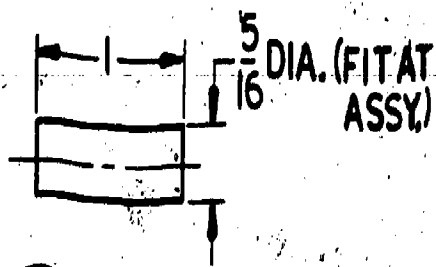

4 DOWEL
MATL. CRS
1 REQD.

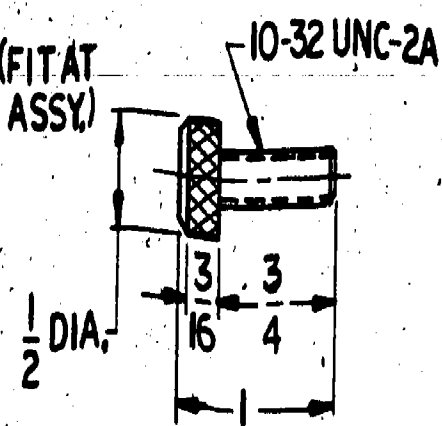

5 ADJ. SCREW
MATL. CRS
1 REQD.

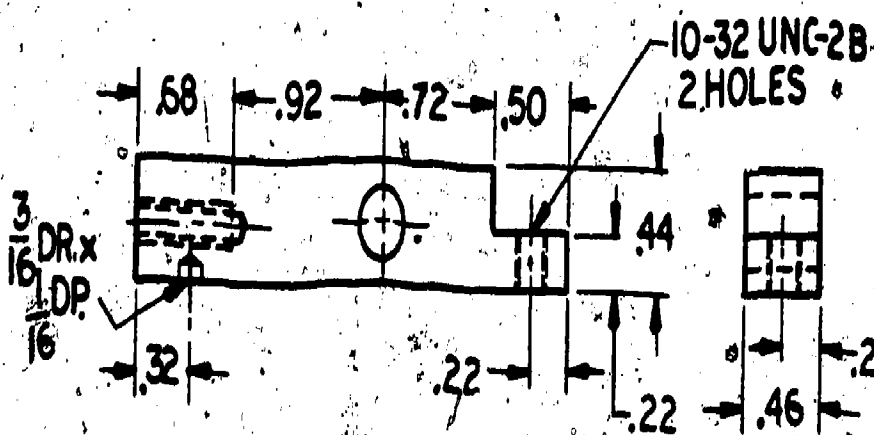

2 ADJ. BAR
MATL. CRS
1 REQD.

1 BASE
MATL. CRS
1 REQD.

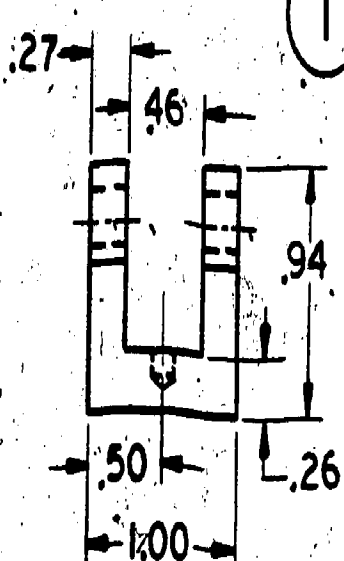
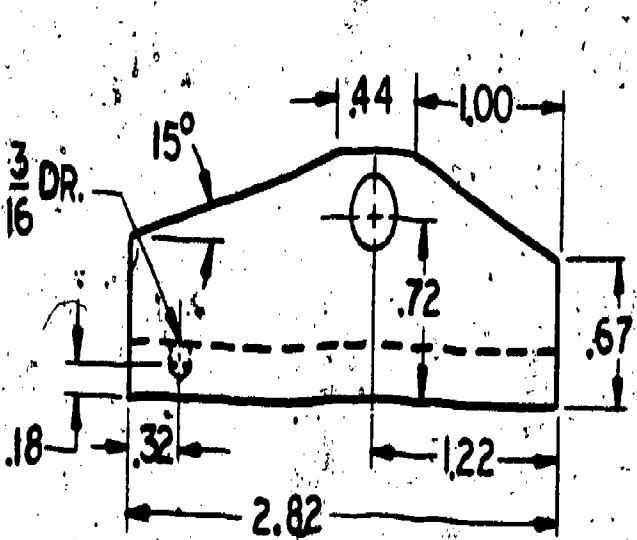

TOLERANCES:
(UNLESS OTHERWISE SPECIFIED)
±.005 ON DECIMAL DIMENSIONS
± 1/64 ON FRACTIONAL DIMENSIONS
± 1° ON ANGULAR DIMENSIONS

DRAWN BY: E.F.S.
SCALE: —

SURFACE GAGE
DETAILS

DWG. NO. 26

99

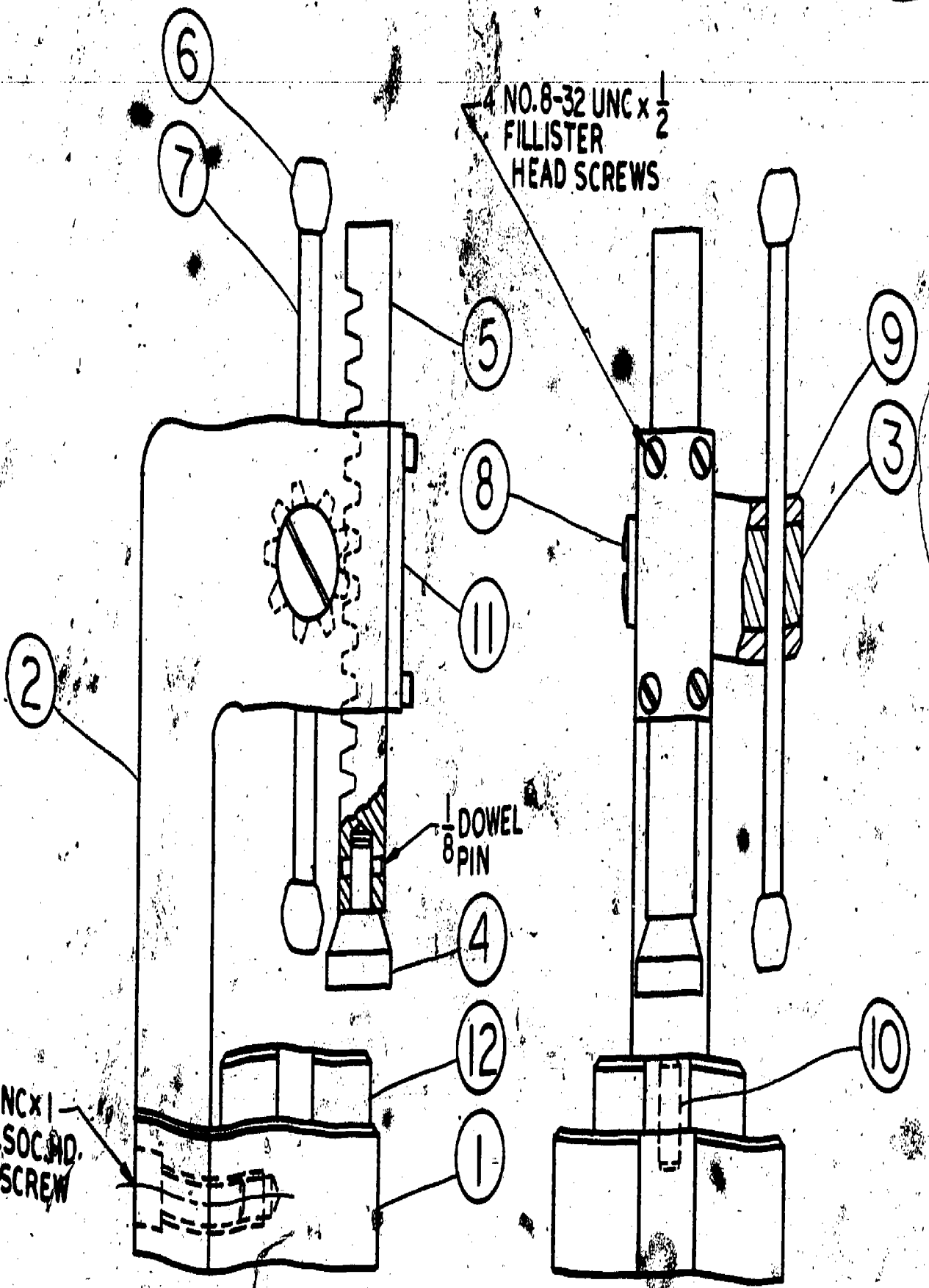

4 NO. 8-32 UNC x 1/2
FILLISTER
HEAD SCREWS

1/8 DOWEL
PIN

3 1/8 16 UNC x 1
HEX. SOC. HD.
CAP SCREW

DRAWN BY: E.F.S.

ARBOR PRESS
ASSEMBLY

DWG. NO. 27

ERIC
Full Text Provided by ERIC

85

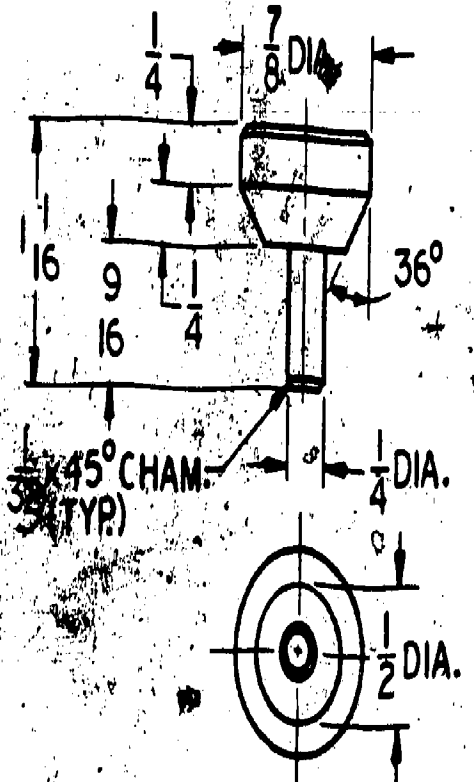
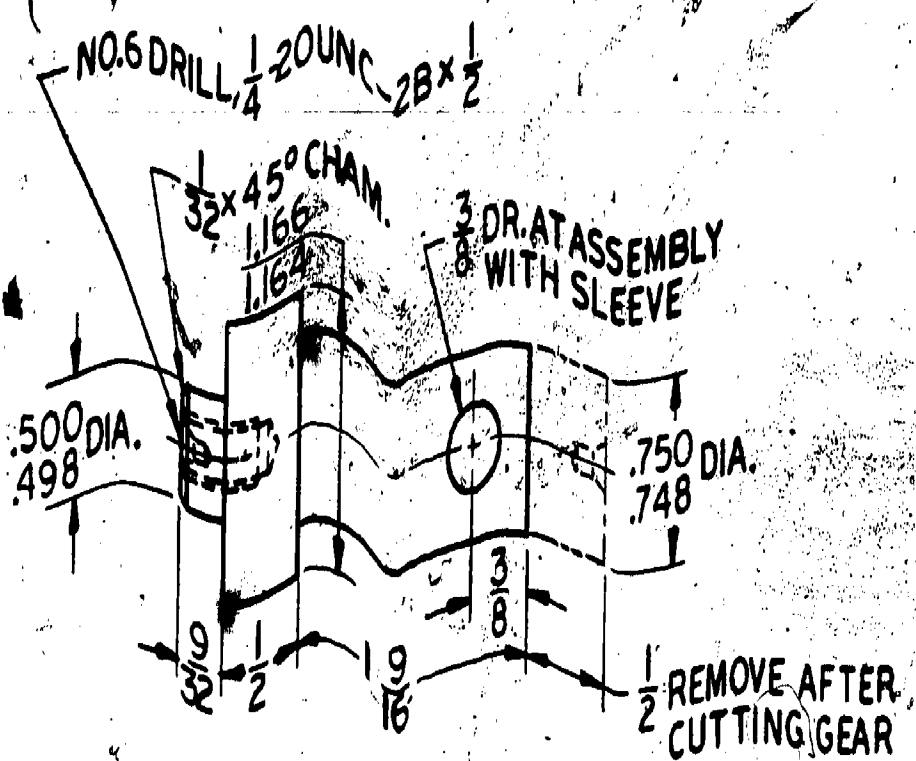

③ GEAR SHAFT
MATL. C1010
1 REQD.

DIAMETRAL PITCH 12
NO. OF TEETH 12

④ RACK PAD
MATL. C1020
1 REQD.

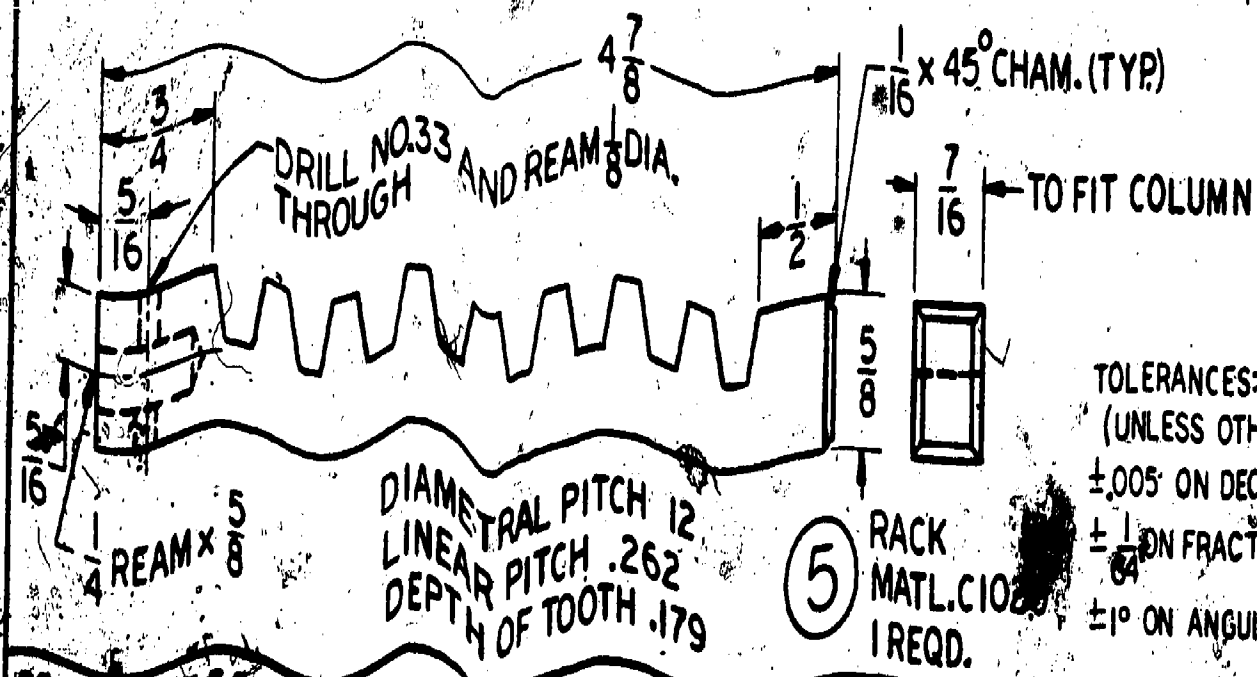

TOLERANCES:
(UNLESS OTHERWISE SPECIFIED)
±.005" ON DECIMAL DIMENSIONS
± $\frac{1}{64}$ " ON FRACTIONAL DIMENSIONS
±1° ON ANGULAR DIMENSIONS

DRAWN BY: [Signature]
SCALE: [Blank]

ARBOR PRESS
GEAR SHAFT, RACK PAD, AND RACK

DWG. NO. 28

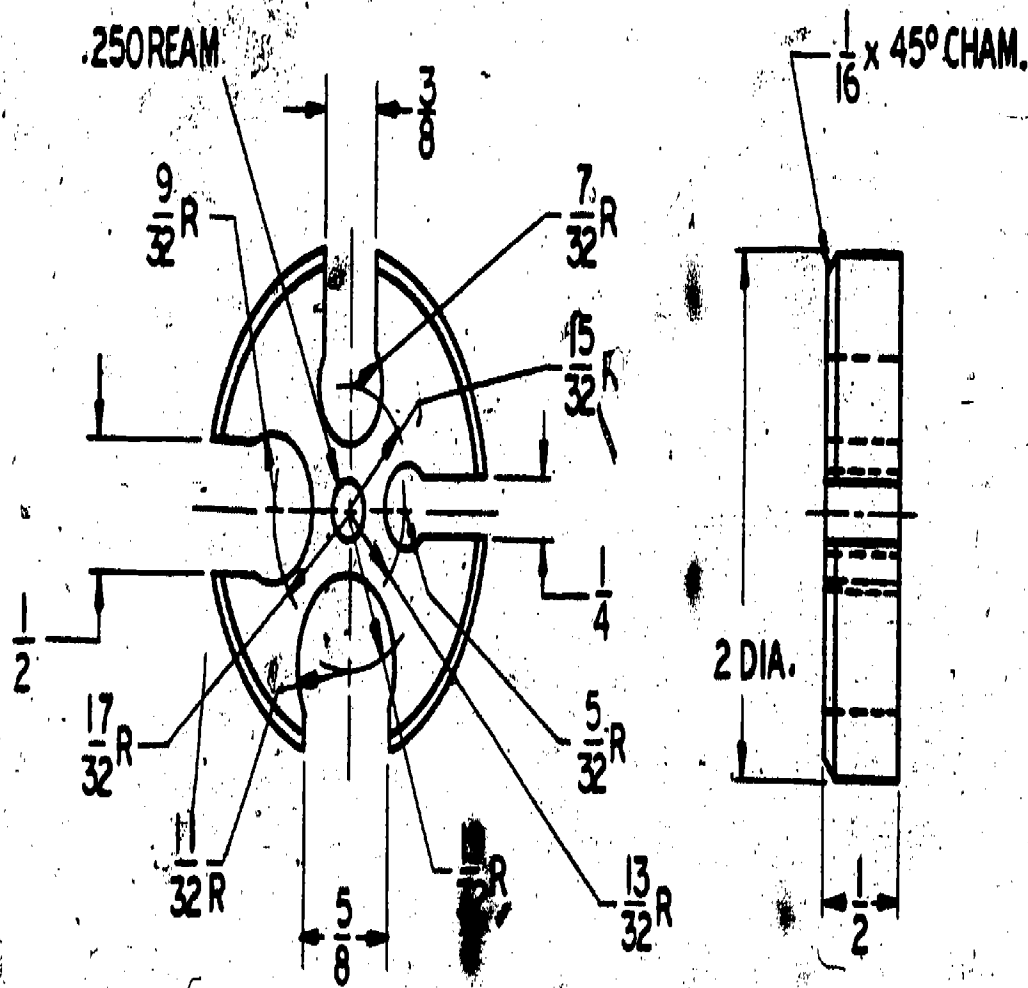

⑫ MATL. C1020
1 REQD.

NOTE:
COUNTERSINK ALL HOLES
TOP AND BOTTOM
BEFORE SLOTTING. 32 DEEP

TOLERANCES:
(UNLESS OTHERWISE SPECIFIED)
± .005 ON DECIMAL DIMENSIONS
± 1/64 ON FRACTIONAL DIMENSIONS
± 1° ON ANGULAR DIMENSIONS

DRAWN BY: E.F.S.

ARBOR PRESS
TABLE

DWG. NO. 29

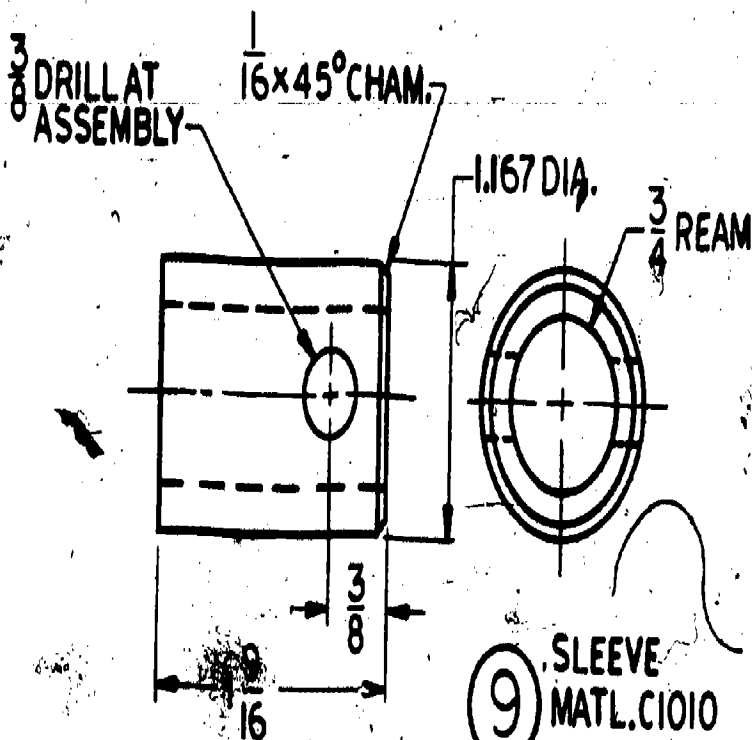

9 SLEEVE
MATL. C1010
1 REQD.

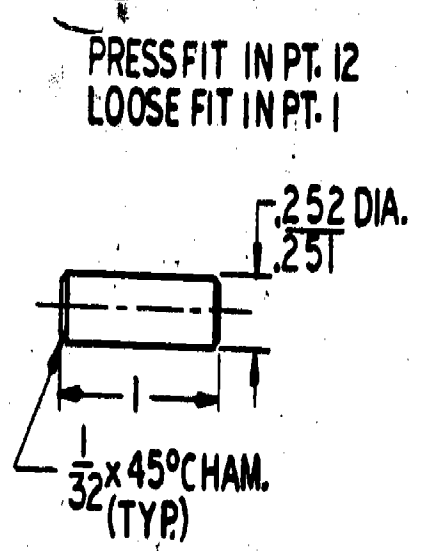

10 TABLE PIN
MATL. C1020
1 REQD.

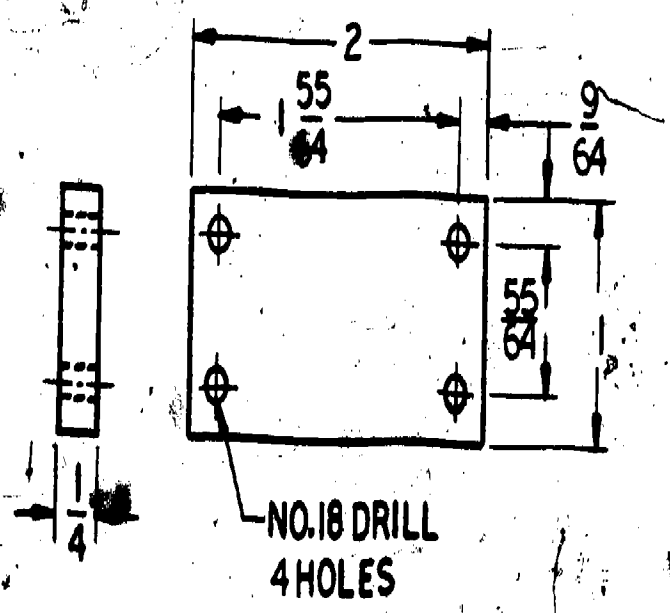

11 COVER PLATE
MAT L. C1010
1 REQD.

TOLERANCES:
(UNLESS OTHERWISE SPECIFIED)
±.005 ON DECIMAL DIMENSIONS
± 1/64 ON FRACTIONAL DIMENSIONS
± 1° ON ANGULAR DIMENSIONS

DRAWN BY: E.F.S.	ARBOR PRESS SLEEVE, TABLE PIN, AND COVER PLATE	DWG. NO. 30
SCALE: —		

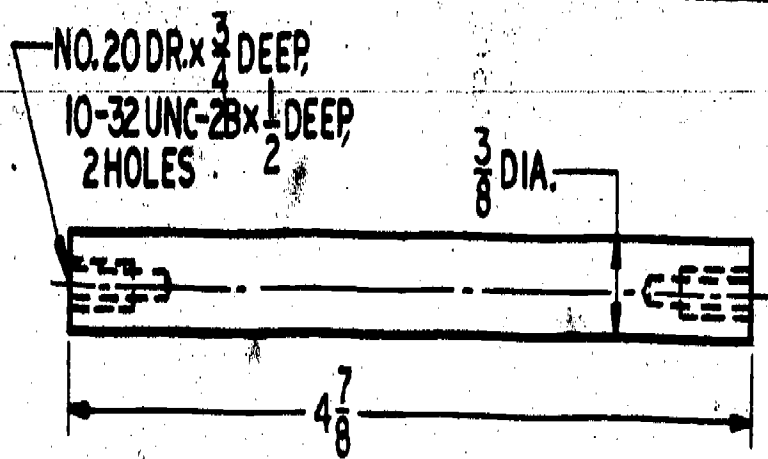

7 HANDLE
 MATL. C1020
 1 REQD.

NO. 10 DRILL THROUGH,
 $\frac{5}{16}$ DIA. CBORE x $\frac{3}{16}$ DEEP,
 $\frac{1}{32}$ CSK. BOTH SIDES

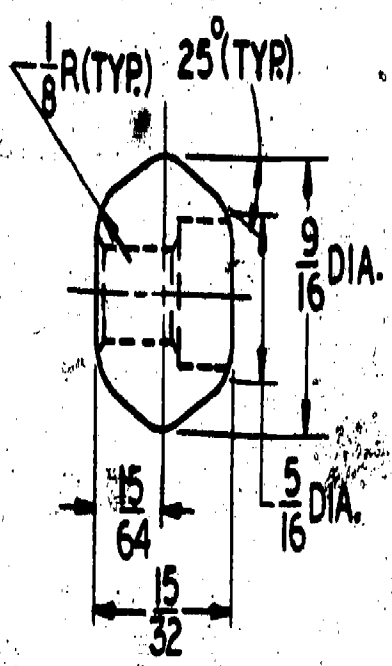

6 HANDLE END
 MATL. CRS
 2 REQD.

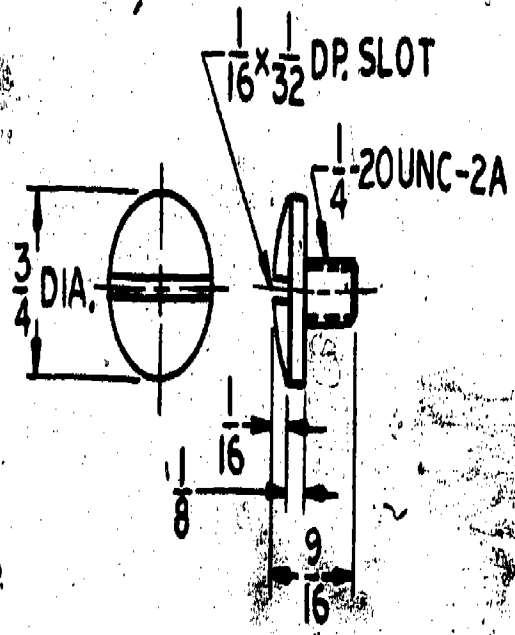

8 GEAR SHAFT SCREW
 MATL. C1020
 1 REQD.

TOLERANCES:
 (UNLESS OTHERWISE SPECIFIED)
 $\pm .005$ ON DECIMAL DIMENSIONS
 $\pm \frac{1}{64}$ ON FRACTIONAL DIMENSIONS
 $\pm 1^\circ$ ON ANGULAR DIMENSIONS

DRAWN BY: E.F.S.

ARBOR PRESS
 HANDLE AND END

DWG. NO. 31

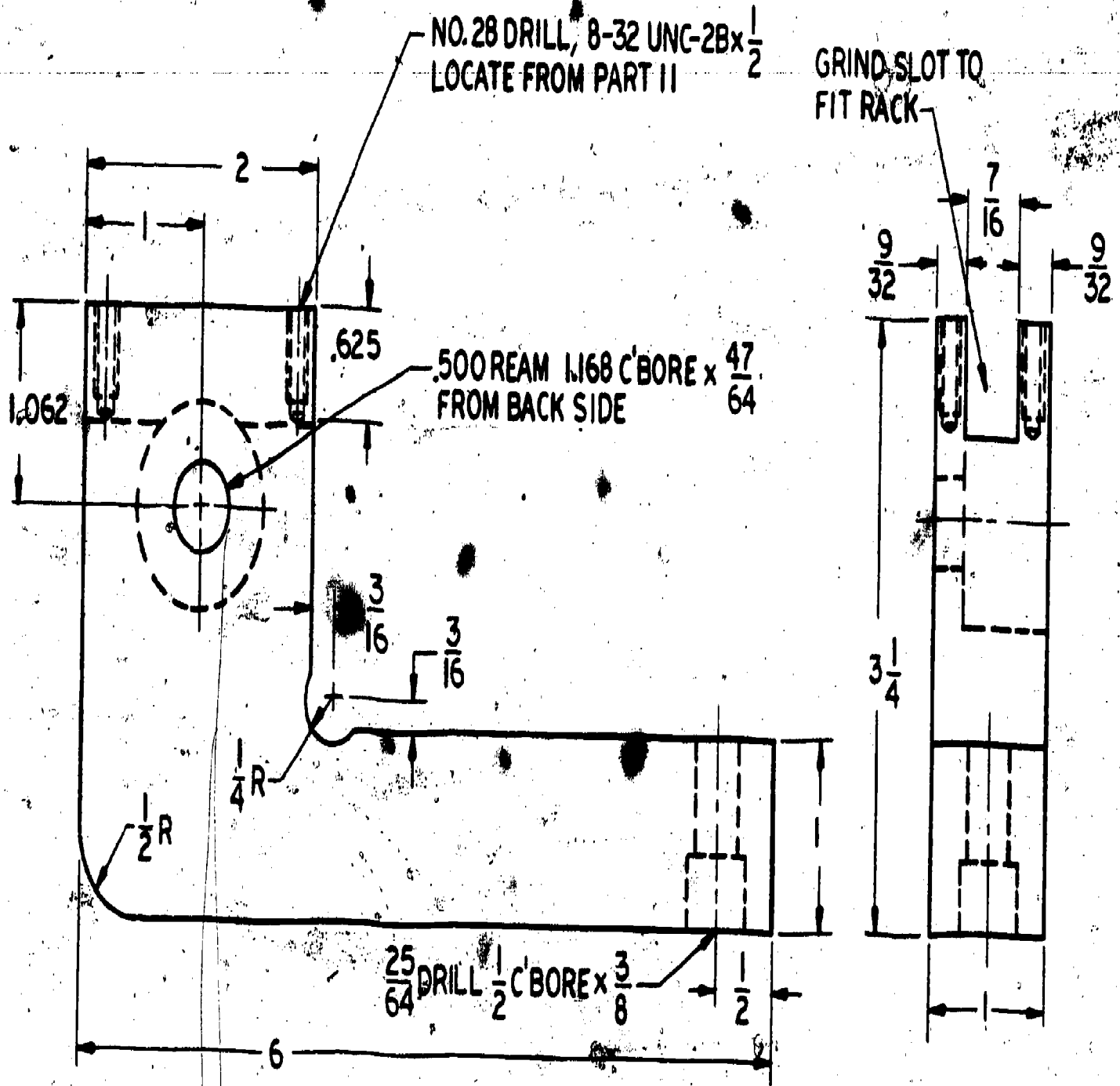

②
MAT L.C1020
1 REQD.

TOLERANCES:
(UNLESS OTHERWISE SPECIFIED)
±.005 ON DECIMAL DIMENSIONS
± $\frac{1}{64}$ ON FRACTIONAL DIMENSIONS
± 1° ON ANGULAR DIMENSIONS

DRAWN BY: E.F.S.

SCALE: —

ARBOR PRESS
COLUMN

DWG.NO.32

GRIND SLOT TO FIT COLUMN

$\frac{1}{16}$ x 45° BEVELED EDGES (TOP AND SIDES)

$\frac{3}{16}$ DRILL 2 HOLES

$\frac{1}{4}$ REAM

$\frac{1}{8}$ DRILL 2 HOLES

$\frac{3}{8}$ -16 UNC-2A x $\frac{3}{4}$

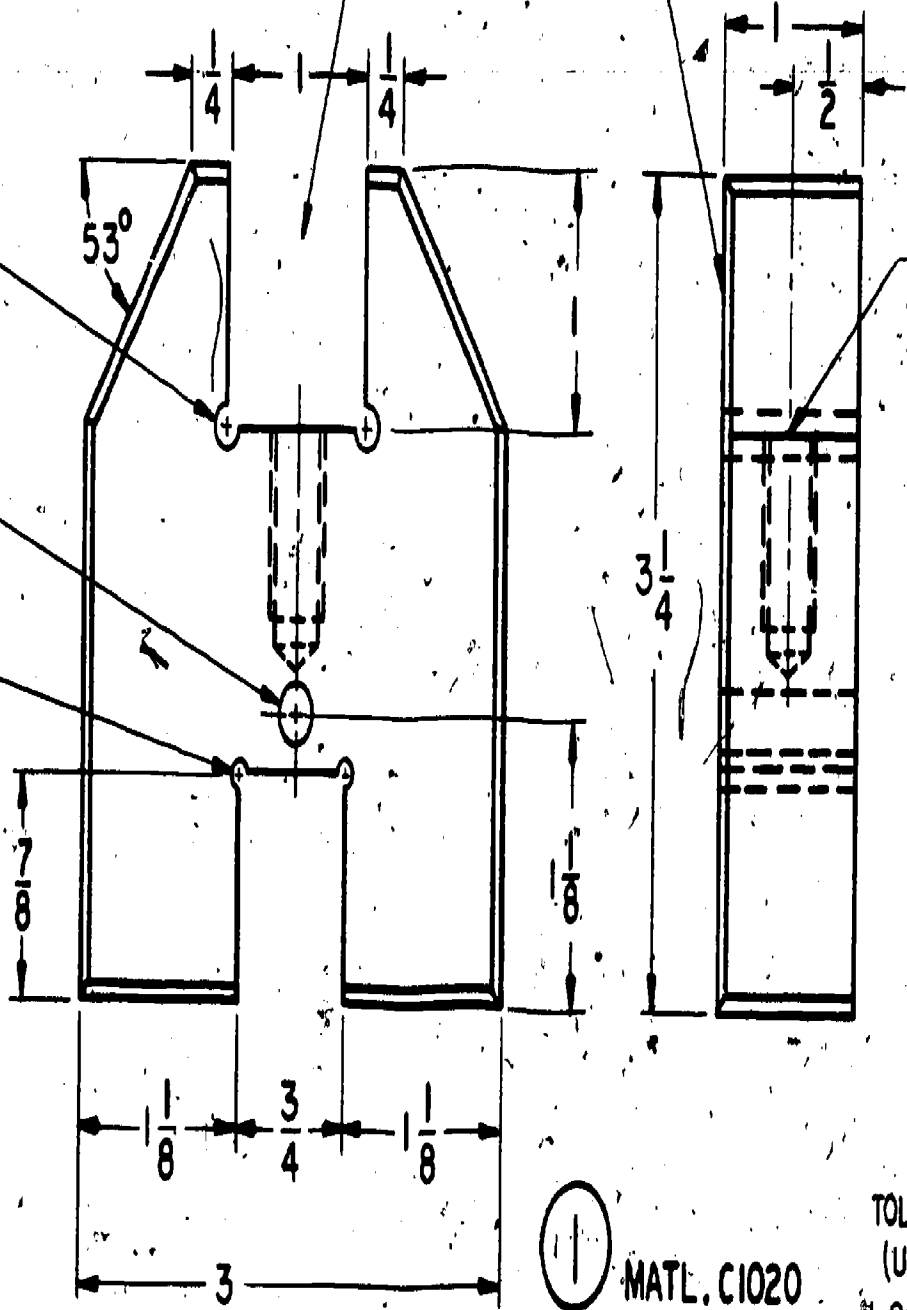

MATL. C1020
1 REQ D.

TOLERANCES:

(UNLESS OTHERWISE SPECIFIED)

±.005 ON DECIMAL DIMENSIONS

± 1/64 ON FRACTIONAL DIMENSIONS

±1° ON ANGULAR DIMENSIONS

DRAWN BY: E.F.S.

ARBOR PRESS
BASE

DWG. NO. 33

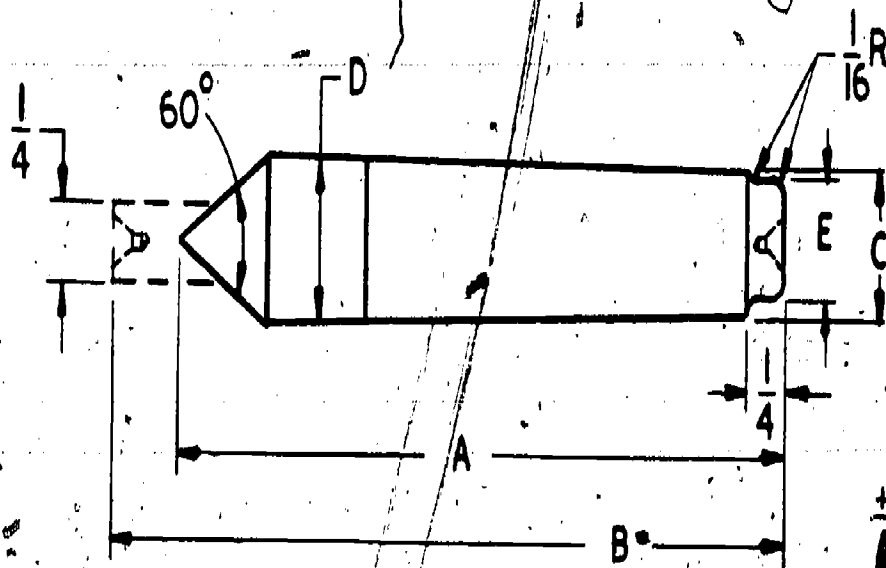

TOLERANCES:
 (UNLESS OTHERWISE SPECIFIED)
 ±.005 ON DECIMAL DIMENSIONS
 ±1/64 ON FRACTIONAL DIMENSIONS
 ±1° ON ANGULAR DIMENSIONS

MORSE TAPER	TAPER PER FT.	A	B	C	D	E
1	.598	3 1/8	3 5/8	.369	.475	.3125
2	.599	4 1/16	4 9/16	.572	.700	.500
3	.602	5 1/16	5 9/16	.778	.938	.625
4	.623	6 7/16	6 15/16	1.020	1.231	.750
5	.631	8 5/16	8 13/16	1.475	1.748	1.000
0	.6246	3 1/8	3 5/8	.252	.3561	.1875

NOTE:

ADD .025 TO DIMENSIONS C AND D FOR GRINDING.
 MATERIAL: TOOL STEEL. HARDEN & DRAW.

DRAWN BY: E.F.S.
 SCALE: —

LATHE CENTER,
 MORSE TAPER

DWG. NO. 35

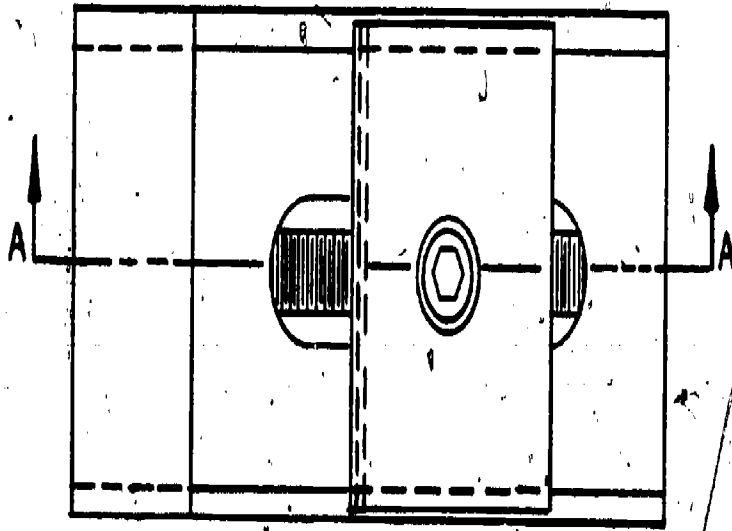

$\frac{1}{4}$ -20 UNC-2A x $\frac{1}{2}$ LG. SET SCREW

$\frac{5}{16}$ -18 UNC-2A x $\frac{5}{8}$ LG. CAP SCREW

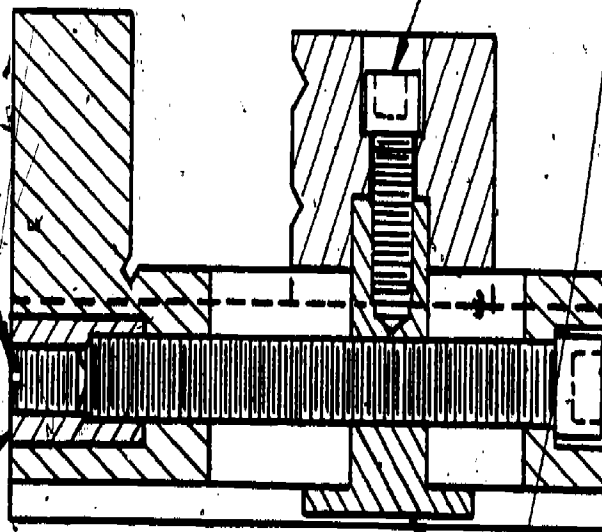

LEAD SCREW

END NUT

LEAD SCREW NUT

SECTION A-A

DRAWN BY: E.F.S

GRINDING VISE ASSEMBLY

DWG. NO. 36

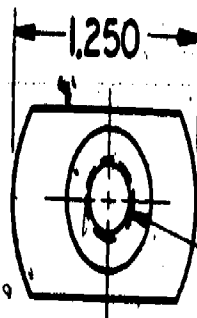

F(.257) DRILL x .650 DP.
 $\frac{5}{16}$ -18 UNC-2B x .500 DP.

$\frac{1}{16}$ x 45° CSK

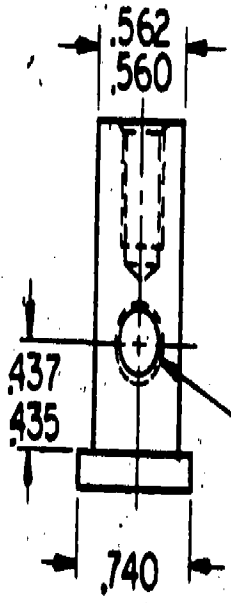
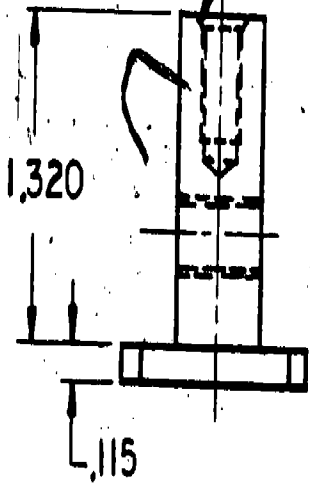

I(.272) DRILL THROUGH
 $\frac{5}{16}$ -24 UNF-2B L.H.

LEAD SCREW NUT

TOLERANCES:
 (UNLESS OTHERWISE SPECIFIED)
 ±.005 ON DECIMAL DIMENSIONS
 ± $\frac{1}{64}$ ON FRACTIONAL DIMENSIONS
 ±1° ON ANGULAR DIMENSIONS

DRAWN BY: E.F.S.
 SCALE: —

GRINDING VISE:
 LEAD SCREW NUT

DWG. NO. 37

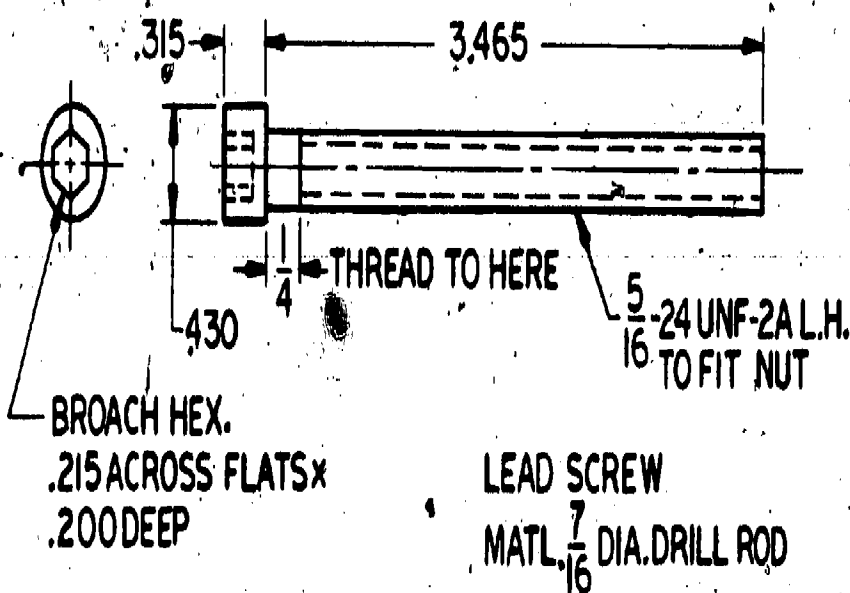

ADDITIONAL PARTS

- SET SCREW $\frac{1}{4}$ -20 UNC-2A x $\frac{1}{2}$ LG.
- CAP SCREW $\frac{5}{16}$ -18 UNC-2A x $\frac{5}{8}$ LG.

LEAD SCREW
MATL. $\frac{7}{16}$ DIA. DRILL ROD

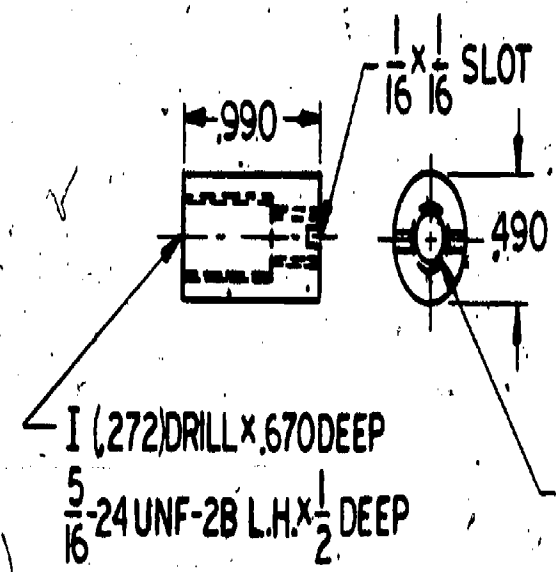

END NUT
MATL. $\frac{1}{2}$ DRILL ROD HARDENED

TOLERANCES:
(UNLESS OTHERWISE SPECIFIED)
±.005 ON DECIMAL DIMENSIONS
± $\frac{1}{64}$ ON FRACTIONAL DIMENSIONS
± 1° ON ANGULAR DIMENSIONS

DRAWN BY: E.F.S.

GRINDING VISE
LEAD SCREW AND END NUT

DWG. NO. 38

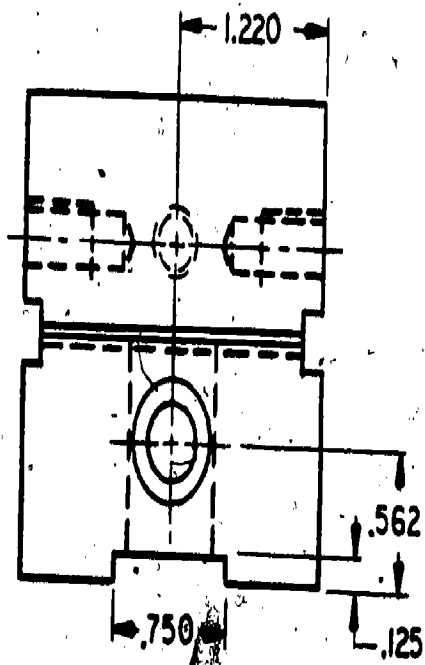
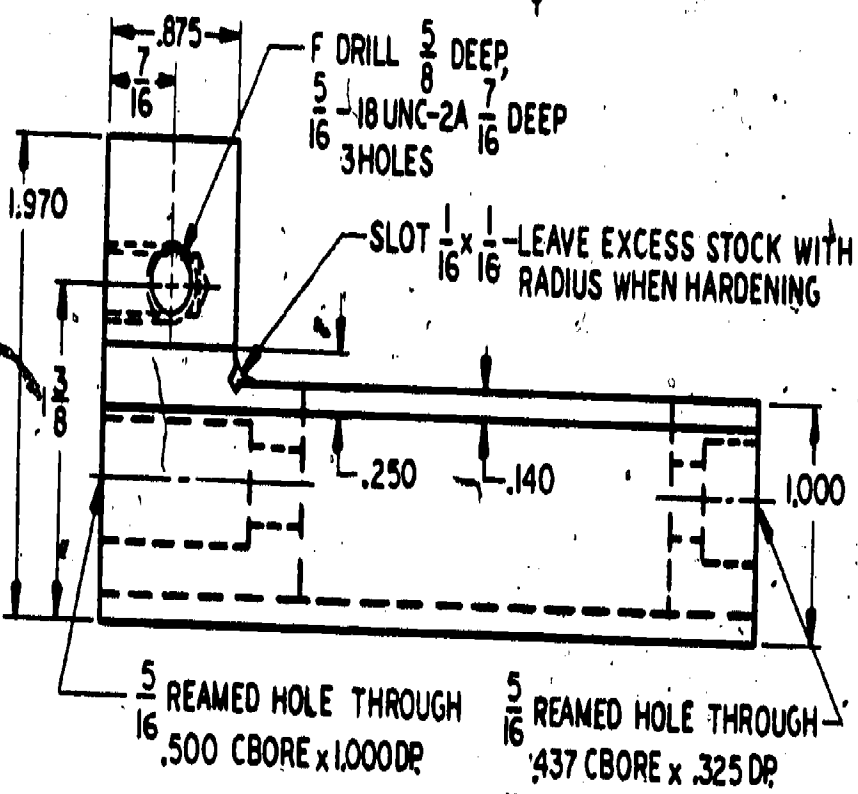
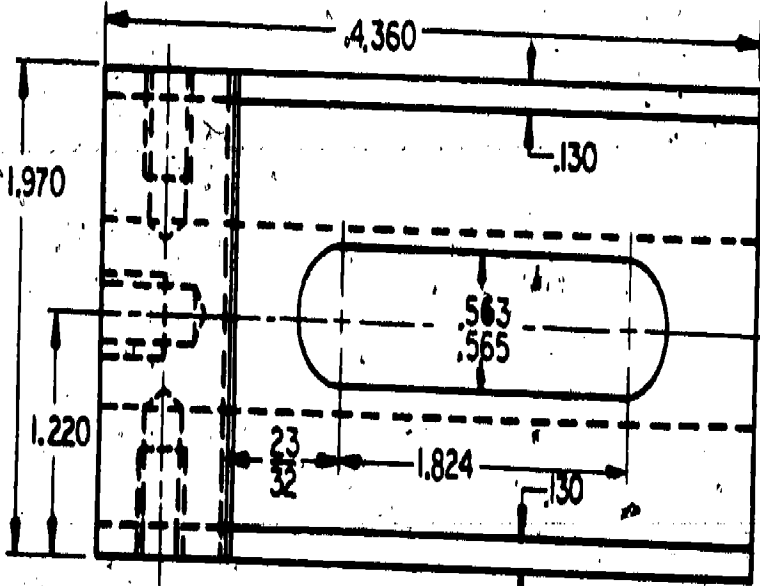

MATL. S.A.E. 1020
CASE HARDEN.

TOLERANCES:
(UNLESS OTHERWISE SPECIFIED)
 $\pm .005$ DECIMAL
 $\pm \frac{1}{64}$ FRACTIONAL
 $\pm \frac{1}{2}^\circ$ ANGULAR

DRAWN BY: E.F.S.

SCALE: —

GRINDING VISE
BASE

DWG. NO. 39

$\frac{5}{16}$ DR. THROUGH
 .437 CBORE. x .330 DP. (CENTERED)

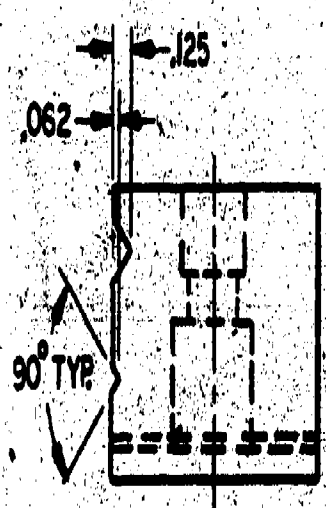
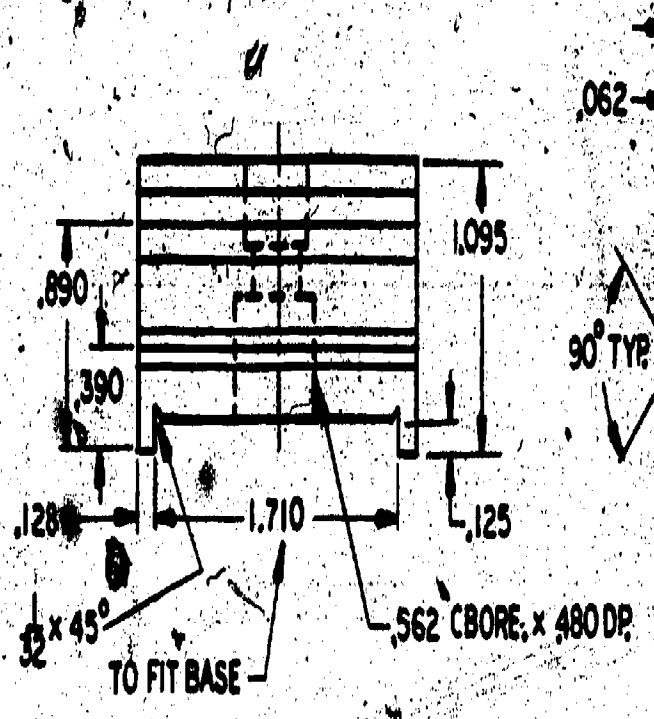
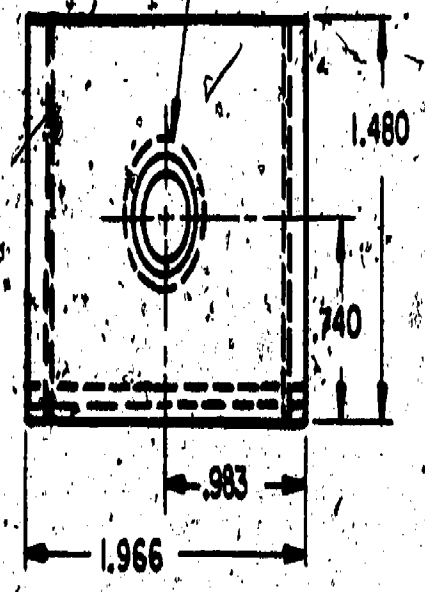

MATL. S.A.E. 1020
 CASE HARDEN

TOLERANCES:
 (UNLESS OTHERWISE SPECIFIED)
 ±.005 DECIMAL
 ± $\frac{1}{64}$ FRACTIONAL
 ± $\frac{1}{2}^\circ$ ANGULAR

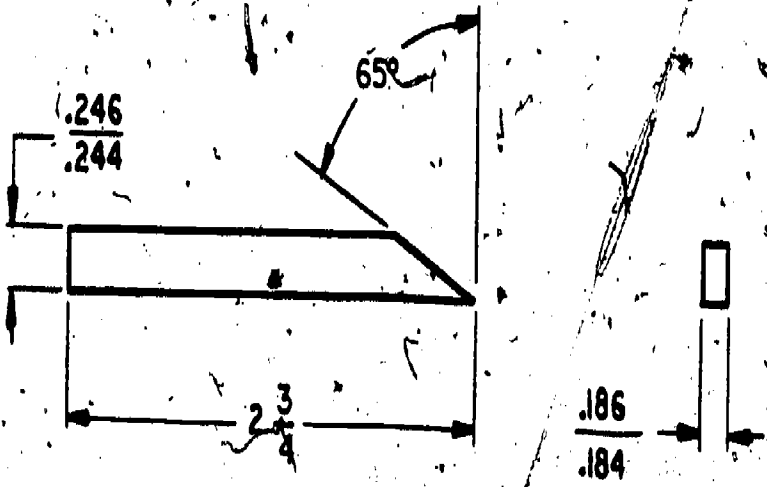

MATL. H.S.(STEEL TOOL BIT)

TOLERANCES:
 (UNLESS OTHERWISE SPECIFIED)
 ±.005 DECIMAL
 ± 1/64 FRACTIONAL
 ± 1/2° ANGULAR

DRAWN BY: E.F.S.

SCRIBER

SCALE: —

DWG.NO. 41

79

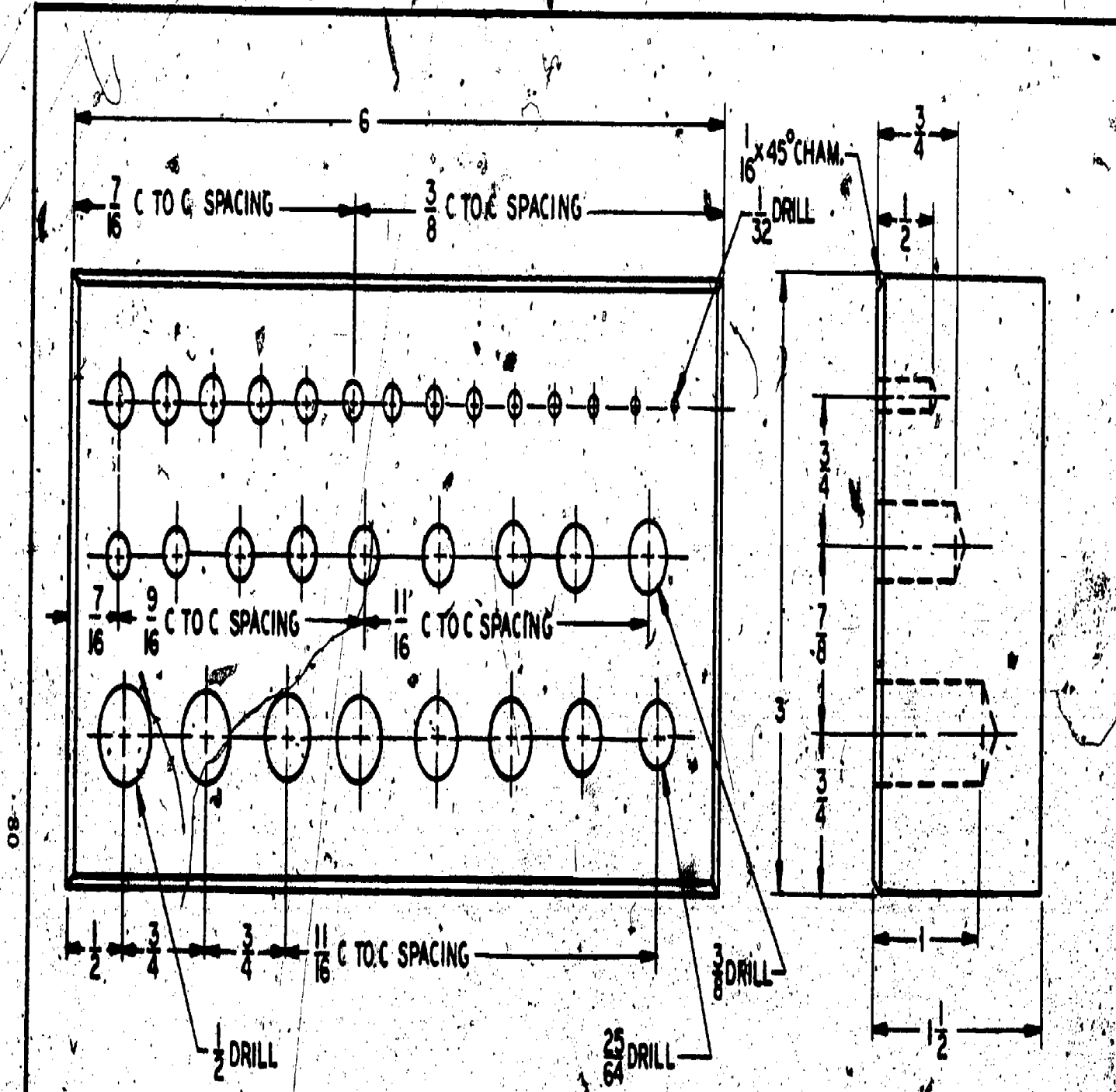

NOTES:
 MATL. CAST ALUM.
 HOLES GO FROM $\frac{1}{32}$ TO $\frac{1}{2}$ BY $\frac{1}{64}$ ths
 FAO

TOLERANCES:
 (UNLESS OTHERWISE SPECIFIED)
 $\pm .005$ DECIMAL
 $\pm \frac{1}{64}$ FRACTIONAL
 $\pm \frac{1}{2}^\circ$ ANGULAR

DRAWN BY: E.F.S.

DRILL STAND

SCALE: _____

DWG. NO. 42

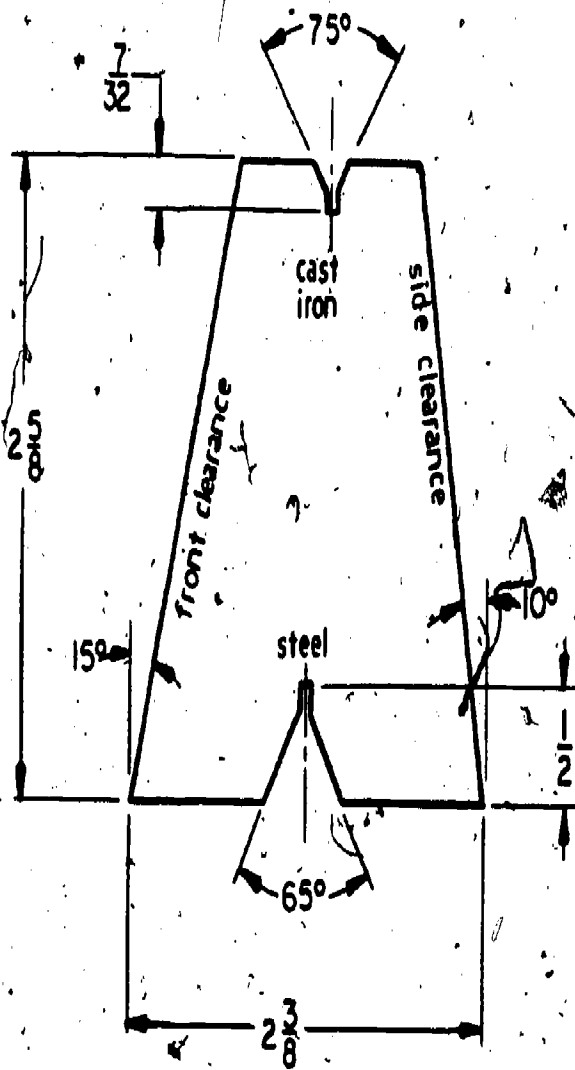

NOTE: WORDS TO BE STAMPED ON
 PLATE AS SHOWN.
 HARDEN AND TEMPER.
 MATL. $\frac{1}{16}$ THICK STEEL GAGE
 PLATE.

TOLERANCES:
 (UNLESS OTHERWISE SPECIFIED)
 $\pm .005$ DECIMAL
 $\pm \frac{1}{64}$ FRACTIONAL
 $\pm \frac{1^\circ}{2}$ ANGULAR

DRAWN BY: E.F.S.

SCALE: —

TOOL BIT GRINDING GAGE

DWG. NO. 43

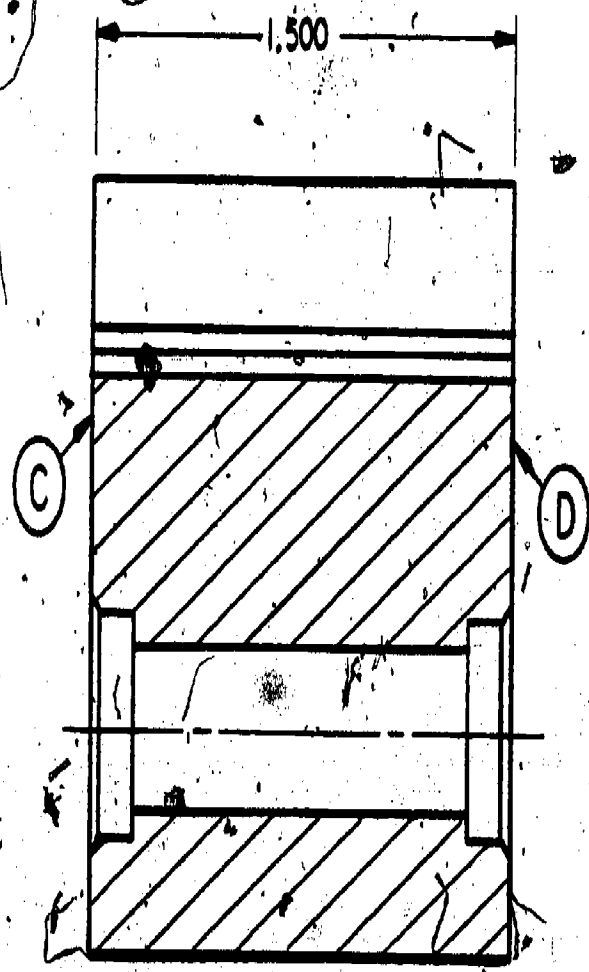
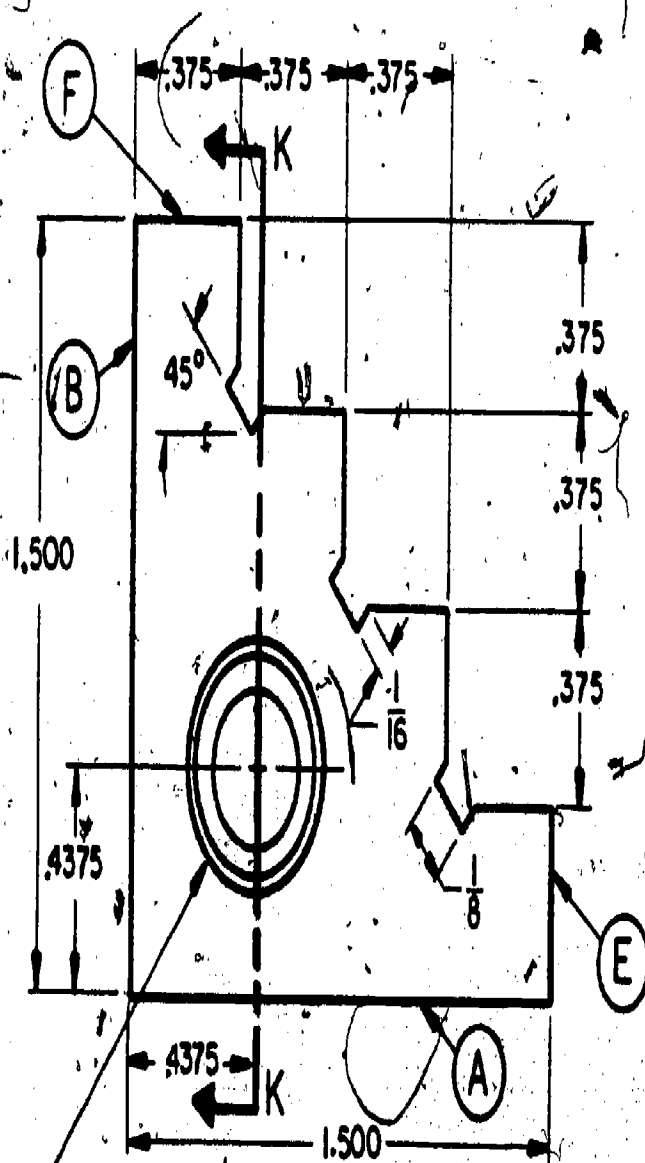

SECTION K-K

$\frac{5}{16}$ DR. THROUGH, $\frac{7}{16}$ CBORE x $\frac{5}{16}$ DR. &
CSINK. $\frac{1}{16}$ DR. BOTH SIDES.

NOTES:
MATERIAL TOOL STEEL
GRIND ALL FLAT SURFACES.
LEAVE .015 ON EACH SURFACE FOR GRINDING.
HEAT TREAT TO 60C ROCKWELL.

TOLERANCES:
(UNLESS OTHERWISE SPECIFIED)
 $\pm .0005$ DECIMAL
 $\pm \frac{1}{64}$ FRACTIONAL
 $\pm \frac{1}{2}^\circ$ ANGULAR

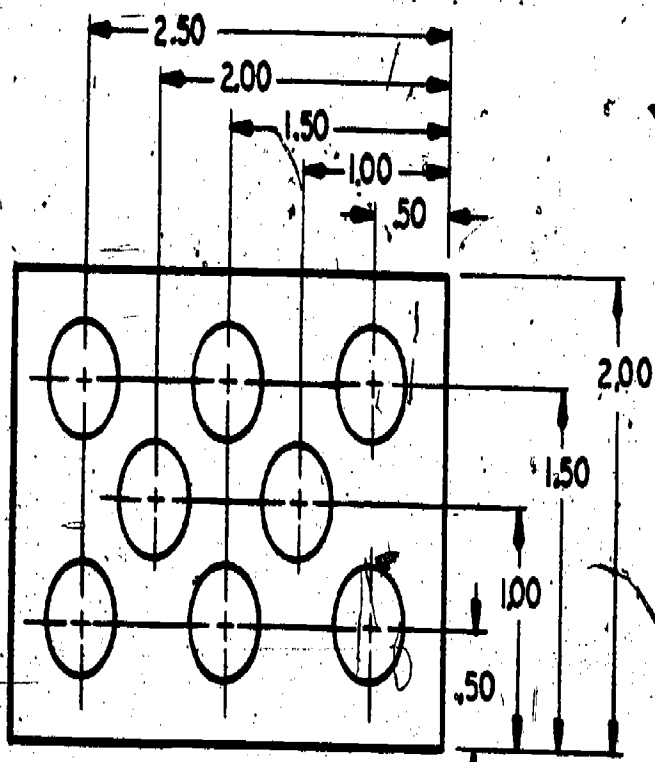
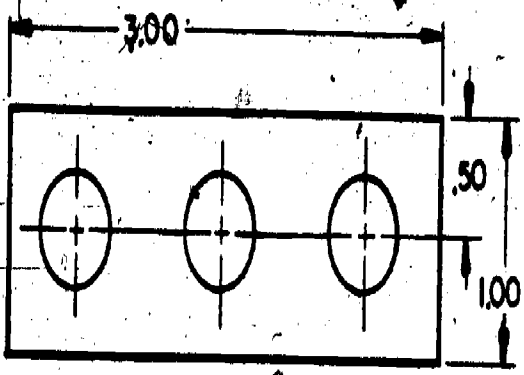

$\frac{31}{64}$ DR. $\frac{1}{2}$ REAM THROUGH
 $\frac{1}{32}$ CSINK 13 HOLES

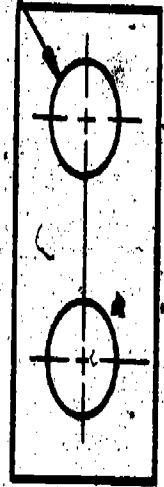

NOTES:
 MATL. SAE 1020
 CASE HARDEN.
 BREAK ALL SHARP CORNERS.
 2REQD.

TOLERANCES:
 (UNLESS OTHERWISE SPECIFIED)
 $\pm .005$ DECIMAL
 $\pm \frac{1}{64}$ FRACTIONAL
 $\pm \frac{1}{2}^\circ$ ANGULAR

DRAWN BY: E.F.S.

SCALE: —

1-2-3 BLOCK

DWG. NO. 45

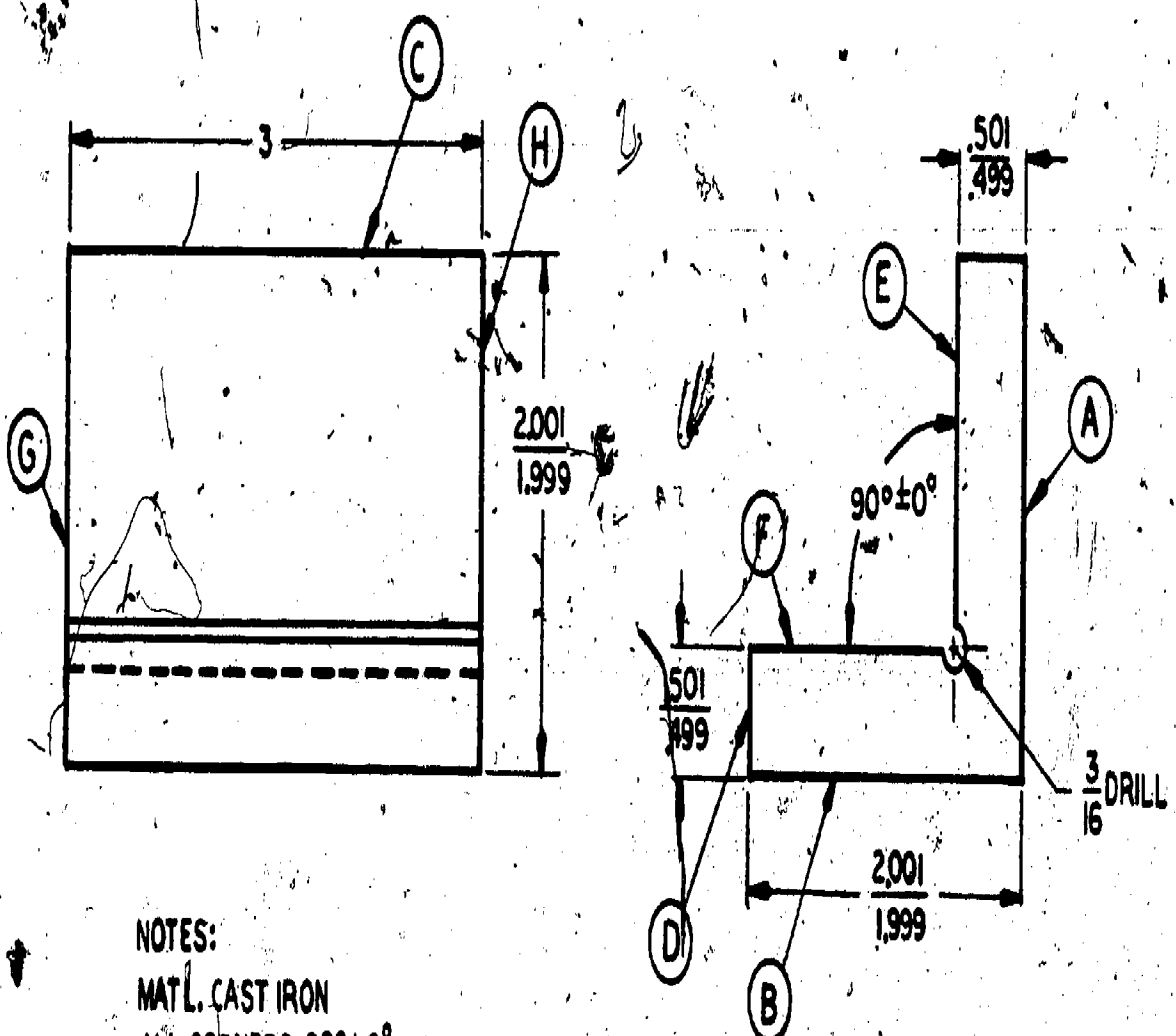

NOTES:
 MATL. CAST IRON
 ALL CORNERS $90^{\circ} \pm 0^{\circ}$

TOLERANCES:
 (UNLESS OTHERWISE SPECIFIED)
 $\pm .005$ DECIMAL
 $\pm \frac{1}{64}$ FRACTIONAL
 $\pm \frac{1}{2}^{\circ}$ ANGULAR

84

120

DRAWN BY: E.F.S.

PRECISION ANGLE PLATE

121

ERIC LE: —

DWG. NO. 46

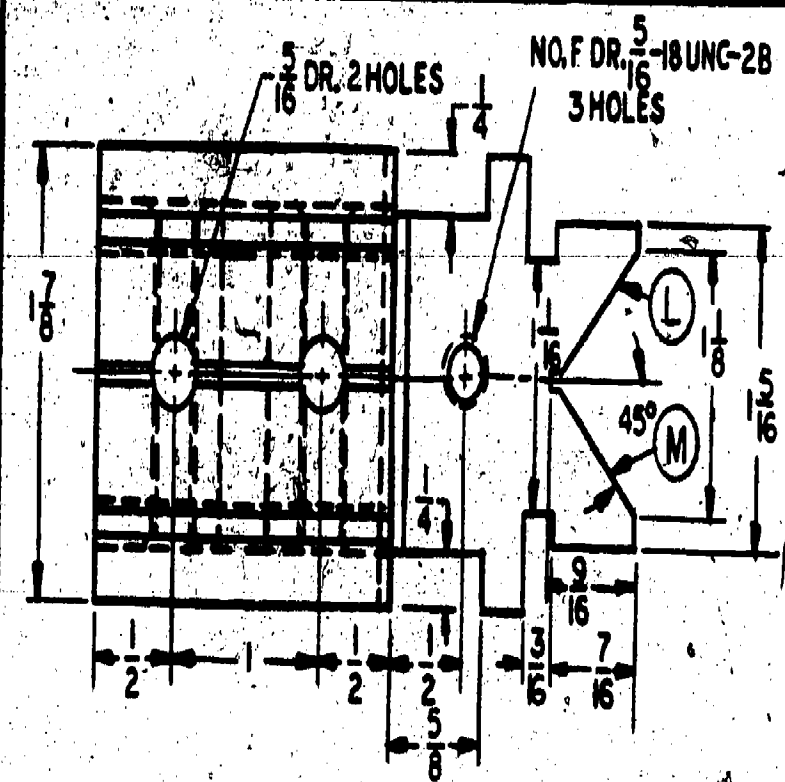

TOLERANCES:
 (UNLESS OTHERWISE SPECIFIED)
 ±.005 DECIMAL
 ± 1/64 FRACTIONAL
 ± 1/2° ANGULAR

① MATL. C.R.S. SAE 1020
 CARBURIZE, HARDEN, AND
 GRIND ALL OVER.

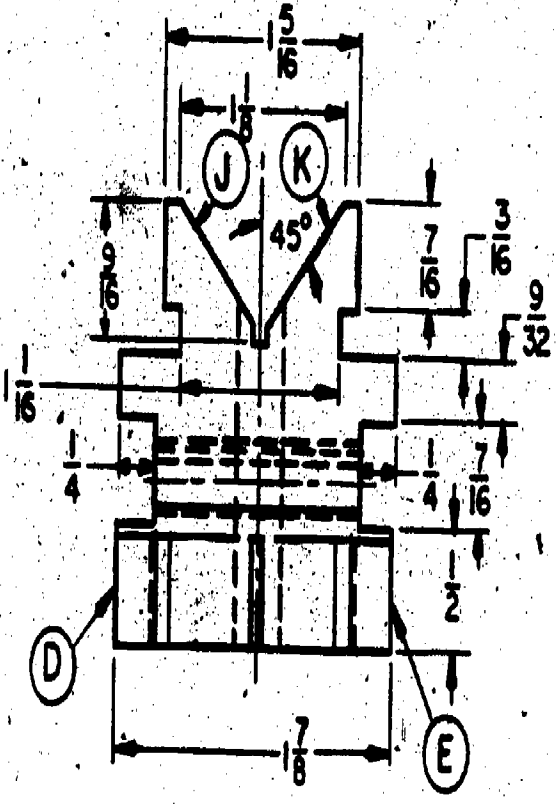
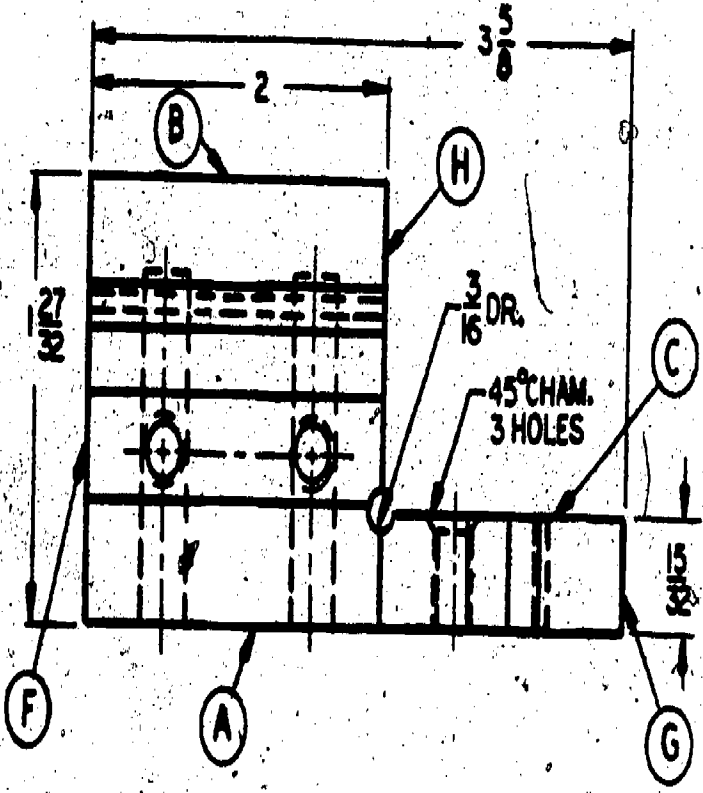

DRAWN BY E.F.S.

SCALE: _____

V-BLOCK

DWG. NO. 47

NO. 21 DRILL
NO. 10-32 UNF-2B



5/16 DIA.

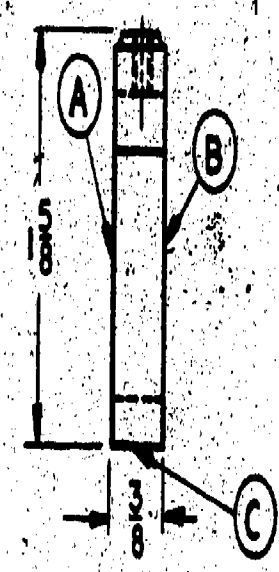
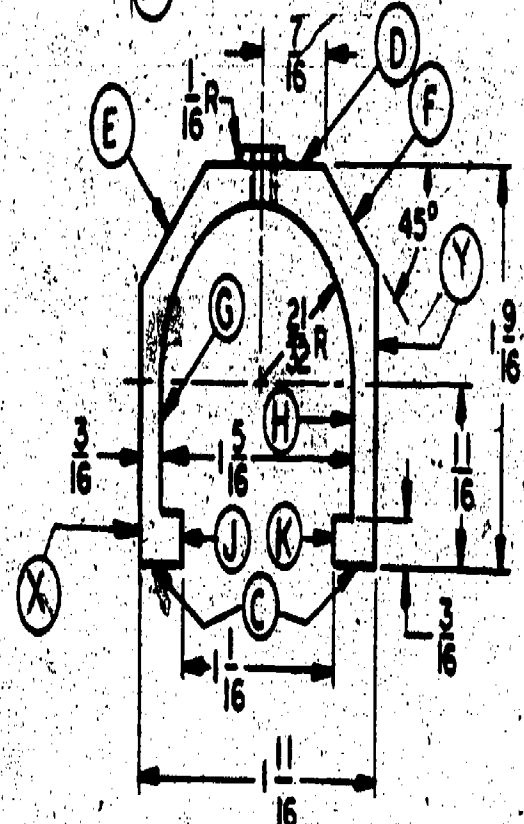

MATL. SAE 1020
FAO

TOLERANCES:
(UNLESS OTHERWISE SPECIFIED)
±.005 DECIMAL
± 1/64 FRACTIONAL
± 1/2° ANGULAR

DRAWN BY: E.F.S.

V-BLOCK
CLAMP

DWG. NO. 48

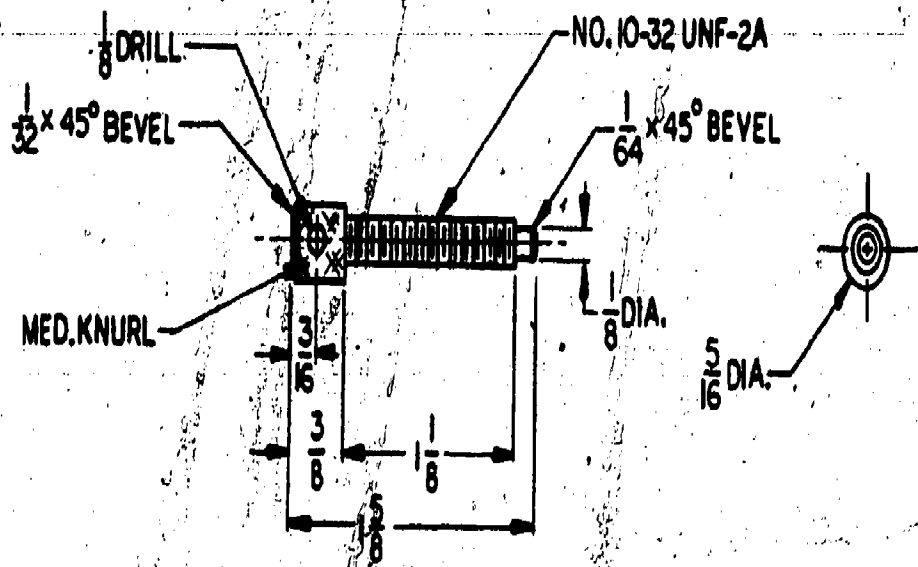

MATL. SAE 1020

TOLERANCES:
 (UNLESS OTHERWISE SPECIFIED)
 $\pm .005$ DECIMAL
 $\pm \frac{1}{64}$ FRACTIONAL
 $\pm \frac{1^\circ}{2}$ ANGULAR

DRAWN BY: E.F.S.

SCALE: _____

V-BLOCK
CLAMP SCREW

DWG. NO. 49

87

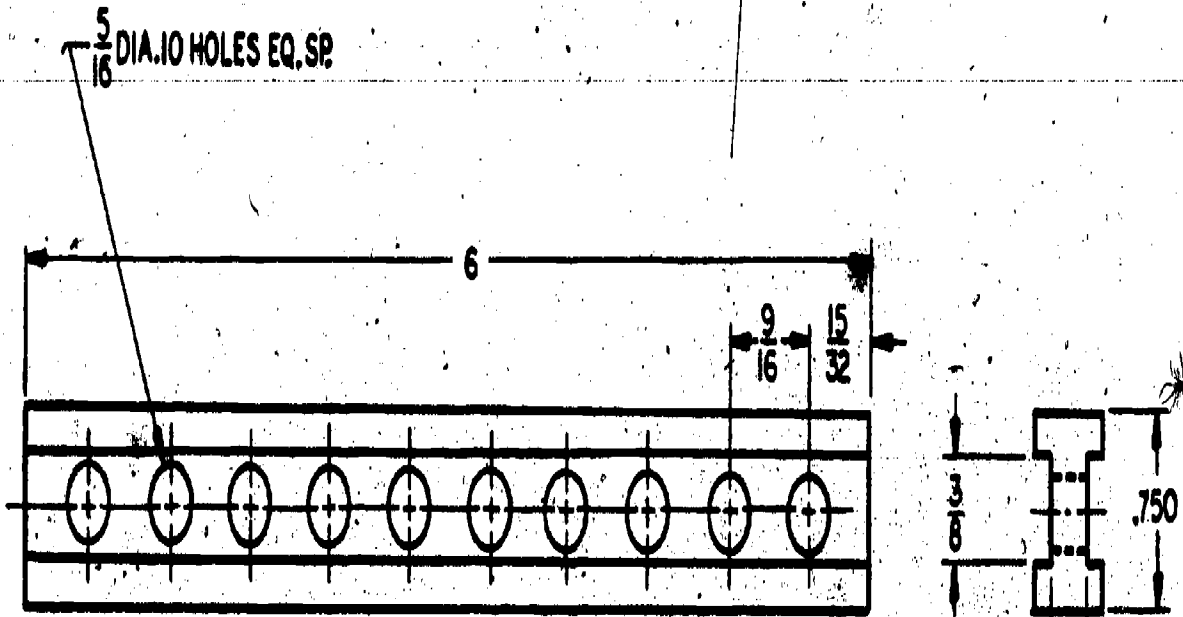

NOTES:
 MATL. C.R.S. SAE 1020
 BREAK ALL SHARP EDGES,
 HARDEN AND TEMPER, FINISH GRIND TO 16 MICROINCHES.
 2 REQD. (MATCHED IN PAIRS)

TOLERANCES:
 (UNLESS OTHERWISE SPECIFIED)
 $\pm .005$ DECIMAL
 $\pm \frac{1}{64}$ FRACTIONAL
 $\pm \frac{1}{2}^\circ$ ANGULAR

88

128 DRAWN BY: E.F.S.

PARALLELS

129

ERIC FILE: —

DWG. NO. 50

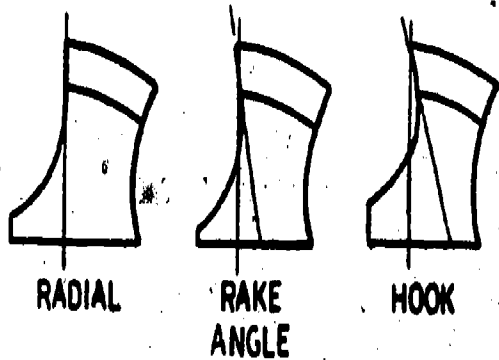
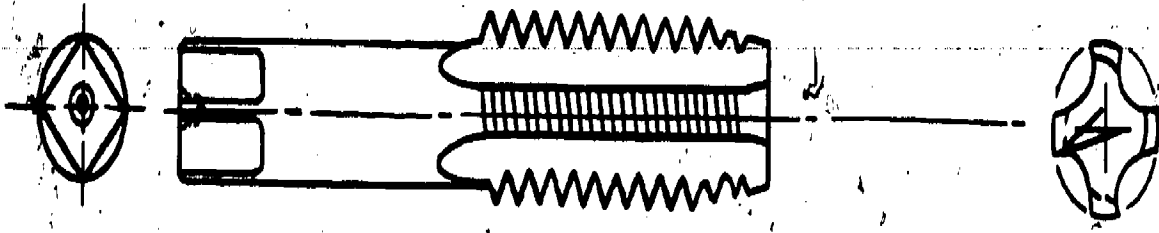

MATERIAL	RAKE
ALUMINUM	20°
BRASS	5°
CAST IRON	3°
LOW CARBON	12°



DRAWN BY: E.F.S.
SCALE: —

THREAD TAP

DWG. NO. 51

06

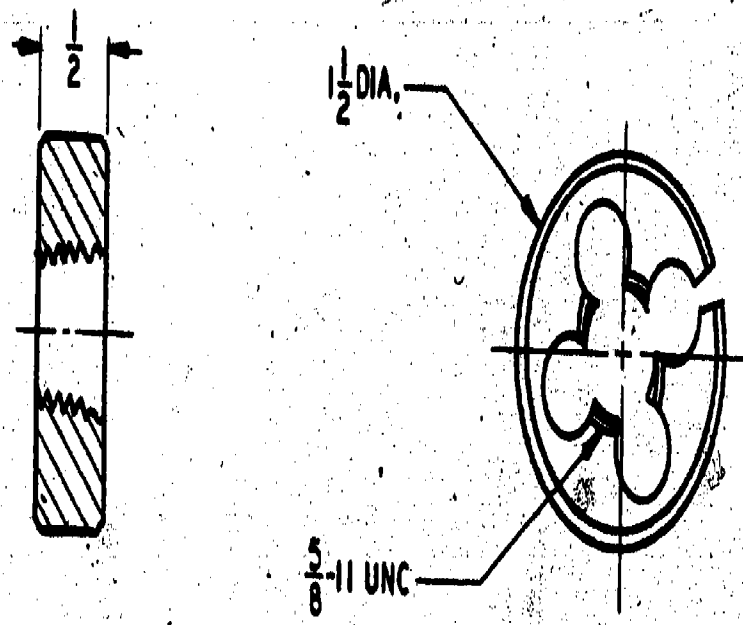

DRAWN BY: E.F.S.

THREAD DIE

DWG. NO. 52

132

133

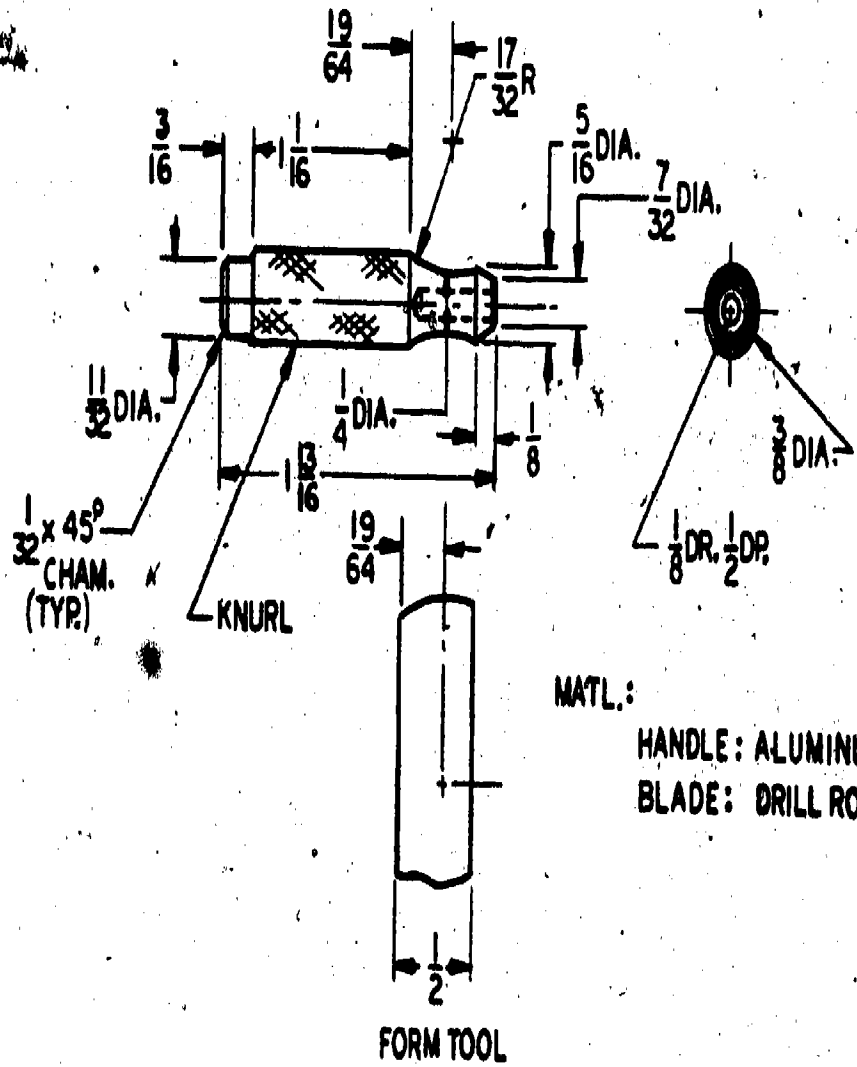

MATL:
 HANDLE: ALUMINUM
 BLADE: DRILL ROD

TOLERANCES:
 (UNLESS OTHERWISE SPECIFIED)
 ±.005 DECIMAL
 ± 1/64 FRACTIONAL
 ± 1/2° ANGULAR

DRAWN BY: E.F.S.
 SCALE: —

FORM TOOL FOR SCREWDRIVER HANDLE

DWG. NO. 53

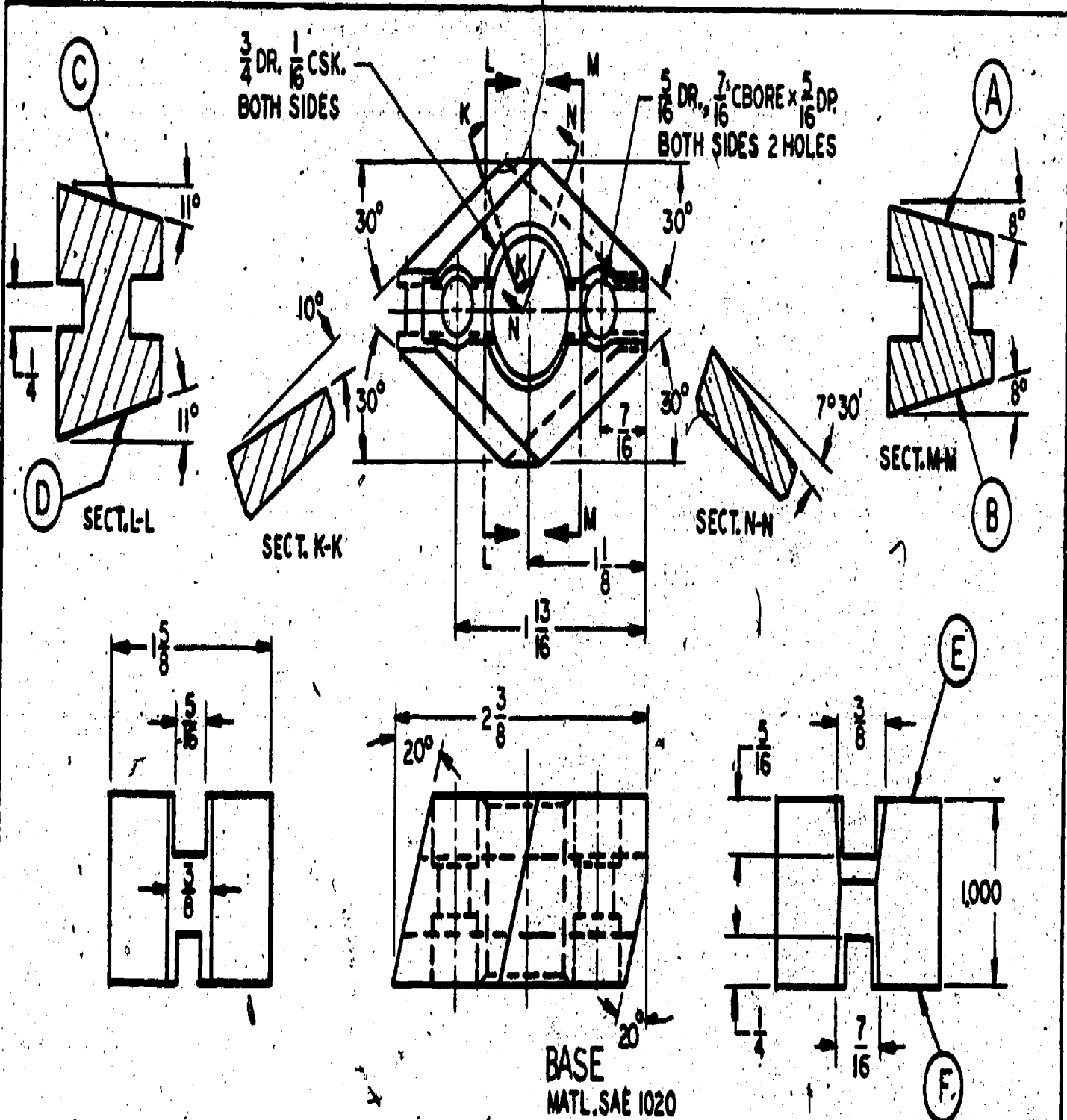

TOLERANCES:
 (UNLESS OTHERWISE SPECIFIED)
 ± .005 DECIMAL
 ± 1/64 FRACTIONAL
 ± 0° ANGULAR

DRAWN BY: E.F.S.
 SCALE: _____

GRINDING FIXTURE FOR THREAD TOOL
 BASE

DWG. NO. 54



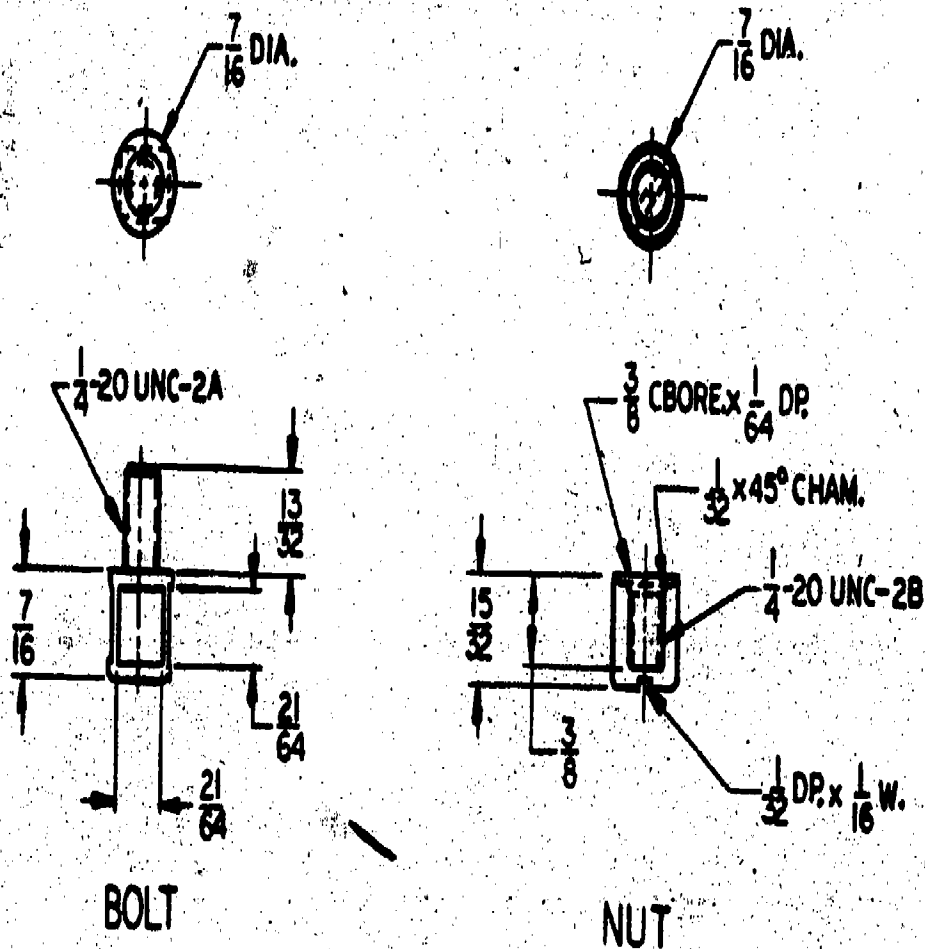

BOLT

NUT

MATL. SAE 1020

TOLERANCES:
 (UNLESS OTHERWISE SPECIFIED)
 ±.005 DECIMAL
 ± 1/64 FRACTIONAL
 ± 1/2° ANGULAR

DRAWN BY: E.F.S.

GRINDING FIXTURE FOR THREAD TOOL
 NUT AND BOLT

SCALE: 1" = 1"

DWG. NO. 55