



This is a digital copy of a book that was preserved for generations on library shelves before it was carefully scanned by Google as part of a project to make the world's books discoverable online.

It has survived long enough for the copyright to expire and the book to enter the public domain. A public domain book is one that was never subject to copyright or whose legal copyright term has expired. Whether a book is in the public domain may vary country to country. Public domain books are our gateways to the past, representing a wealth of history, culture and knowledge that's often difficult to discover.

Marks, notations and other marginalia present in the original volume will appear in this file - a reminder of this book's long journey from the publisher to a library and finally to you.

Usage guidelines

Google is proud to partner with libraries to digitize public domain materials and make them widely accessible. Public domain books belong to the public and we are merely their custodians. Nevertheless, this work is expensive, so in order to keep providing this resource, we have taken steps to prevent abuse by commercial parties, including placing technical restrictions on automated querying.

We also ask that you:

- + *Make non-commercial use of the files* We designed Google Book Search for use by individuals, and we request that you use these files for personal, non-commercial purposes.
- + *Refrain from automated querying* Do not send automated queries of any sort to Google's system: If you are conducting research on machine translation, optical character recognition or other areas where access to a large amount of text is helpful, please contact us. We encourage the use of public domain materials for these purposes and may be able to help.
- + *Maintain attribution* The Google "watermark" you see on each file is essential for informing people about this project and helping them find additional materials through Google Book Search. Please do not remove it.
- + *Keep it legal* Whatever your use, remember that you are responsible for ensuring that what you are doing is legal. Do not assume that just because we believe a book is in the public domain for users in the United States, that the work is also in the public domain for users in other countries. Whether a book is still in copyright varies from country to country, and we can't offer guidance on whether any specific use of any specific book is allowed. Please do not assume that a book's appearance in Google Book Search means it can be used in any manner anywhere in the world. Copyright infringement liability can be quite severe.

About Google Book Search

Google's mission is to organize the world's information and to make it universally accessible and useful. Google Book Search helps readers discover the world's books while helping authors and publishers reach new audiences. You can search through the full text of this book on the web at <http://books.google.com/>

NYPL RESEARCH LIBRARIES



3 3433 00634832 4



THE SEVENTEENTH
BOOK OF SPECIMENS

2772

FROM THE

CINCINNATI TYPE FOUNDRY

(ESTABLISHED 1817)

COMPACT EDITION

HENRY BARTH, PRESIDENT

WM. P. HUNT, TREASURER



OFFICE, 201 VINE STREET
WORKS, 7 to 17 LONGWORTH STREET
1888

27



PREFACE.

WE now present to our patrons, and the trade generally, our SEVENTEENTH BOOK OF SPECIMENS, containing a selection of our latest productions, and also choicest faces made by other type founders.

All type made by us is cast on the uniform Didot, or Point, system, now adopted and being introduced by all the leading foundries in this country.

Our newly-invented and patented Automatic Type Machines enable us to use a superior metal, and give a finish and accuracy to our type not equalled in the world.

In Borders, readily composed and capable of many combinations, we are ahead of all competition.

Our Brass Rule, made on a new principle, is superior to any in the market; the finest lines being round—not knife-edged—and all the counters being round, it is easily cleaned, and specially adapted for electrotyping.

Our Printing Machinery, so favorably known throughout the West and South, is kept up to rank with the best.

Woodwork, made in our own shops, is of the best material and workmanship.

Goods made by other founders, and not shown in this book, are promptly furnished by us at prices advertised by the manufacturers.

We manufacture a greater variety of Printing Material than any other house in the world, and are headquarters for goods in our line.

We solicit your patronage.

THE CINCINNATI TYPE FOUNDRY.

* HINTS ABOUT ORDERS *

WHEN ordering Book or Newspaper Type, state whether or not Italic or Leaders are wanted.

When ordering Sorts, or additions to fonts, always send cap H and lower-case m; and state number of face as well as body. This is absolutely necessary now, on account of change in bodies.

When ordering Job Type, such as Titles, Gothics, Antiques, etc., state whether or not quads and spaces are wanted. They are not sent if not specially named in order, and charged extra when sent.

When giving measure for Leads and Slugs by ems, without specifying body, pica ems are always understood.

When ordering Brass Rules to be mitered, state whether the size given is to be inside or outside of miters.

When orders for mitered Double Rules are received, it is always understood that the heavy line is to be on the outside, unless otherwise stated.

When ordering chases, send diagram with correct inside and outside measures marked.

When ordering material from a specimen book not our own, state name of the founder from whose book selections are made.

When writing an order, put each item on a line by itself, and do not mix things up; show plainly whether the quantity that follows or precedes an article is the amount wanted.

When writing for information, tell us what you want us to do, rather than ask us what we can do. Knowing your wants, we aim to supply them; to ask us what we can do, is to set us to guessing what you want.

Always indicate the way of shipping—whether by railroad, steamboat or express.

When shipping old type, mark your own name, as well as ours, on every package.

When writing for special terms or prices, always send copy of proposed order.

PRICE LIST

TYPES, PRESSES

AND
PRINTING MATERIAL GENERALLY.

1888.

Applicants, for large bills of material on special terms, will please send complete copy of proposed order, tell us how much cash they will pay down, and how much time is desired on balance; and, if strangers to us, send references, and we will reply by telegraph at our cost.

PRICES SUBJECT TO CHANGES WITHOUT NOTIFICATION.

TERMS • CASH

In all cases where a Special Time is not agreed upon.

ACCENTS—Double the price of Romans. See TYPE.

ADVERTISING RULES—

Single, column width, each	\$ 0 04
Wave, " " "	4
Parallel, " " "	6
Double, " " "	6

ALGEBRAIC SIGNS. See SIGNS.

ALMANAC SIGNS. See SIGNS.

AWLS. See BODKINS.

BEARERS—

For Hand-Presses, per pair	40
----------------------------	----

BELLOWS—

Each	\$1 00, 1 25
------	--------------

BELTING—

Width.	Per foot.	Width.	Per foot.
2 inches	\$0 18	2 3/4 inches	25
2 1/4 "	20	3 "	28
2 1/2 "	23	3 1/2 "	33

BLANKETS FOR CYLINDER PRESSES—

Felt, 28×40	5 50
" 31×46	6 25
" 33×48	6 75

Other sizes, 15 cents per running inch, yard width.

Rubber, 28×40	8 80
" 31×46	10 10
" 33×48	10 55

Other sizes, 22 cents per running inch, yard width.

BODKINS—

Common Awls	10
Spring Bodkins	50
Closing Spring Bodkin	60
Printer's Knife	1 50
Bodkin and Knife	1 75

BOOKS—

American Printer	2 00
Treatise on Punctuation (Wilson)	2 00
Employing Printers' Price List, for Job Work;	
Ramaley	1 00
Paper and Printing Receipts; Ford	1 00

BRASS BRACES—

Nos. 1-10, each	\$0 12	Nos. 23-27, each	\$0 25
Nos. 11-17, " "	15	Nos. 28-32, " "	30
Nos. 18-22, " "	18	Nos. 33-38, " "	12
Complete set	5 60		

BRASS CIRCLES—

Nos. 1-6, each	\$0 60	Nos. 14-18, each	1 00
Nos. 7-13, " "	75	Nos. 19-20, " "	1 25

BRASS CORNER QUADS—

Per set of four	15
-----------------	----

BRASS CURVES AND CLAMPS—

Per font of 180 pieces	8 00
------------------------	------

BRASS DASH RULES—

Single, column width	4
Double, " "	5

BRASS FLOURISHES—

Whole font	8 00
Half font	5 00

BRASS LABEL HOLDERS—

Per dozen	35
Per 100	1 00

BRASS LEADS—

Six-to-pica, cut to measure	50
Ten-to-pica, cut to measure	75

BRASS LEADERS—

Nonpareil, per lb.	\$1 60	Lg. Prim., per lb.	1 50
Brevier, " "	1 60	Pica, " "	1 40

BRASS OVALS—

Nos. 1-6, each	\$0 90	Nos. 13-17, each	1 25
Nos. 7-12, " "	1 00	Nos. 18-21, " "	1 50

BRASS RULES—

Body.	In two feet		Cut labor-saving of ten feet.	Smallest fonts of ten feet.	Price.
	Per foot.	Per lb.			
Pica	\$0 50	\$1 50	6 lbs., 0 oz.		\$9 00
Long Primer	40	1 50	4 lbs., 8 oz.		6 75
Brevier	34	1 50	4 lbs., 0 oz.		6 00
Minion	32	1 50	3 lbs., 5 oz.		5 00
Nonpareil	28	1 60	3 lbs., 0 oz.		4 80
Pearl	18	1 60	2 lbs., 4 oz.		3 60
Three-to-Pica	14	1 60	1 lb., 14 oz.		3 00
Four-to-Pica	12	1 60	1 lb., 8 oz.		2 40
Five-to-Pica	10	1 70	1 lb., 2 oz.		1 90
Six-to-Pica	8	1 70	1 lb., 2 oz.		1 90
Eight-to-Pica	6	2 00	12 oz.		1 50
Ten-to-Pica	5	2 00	10 oz.		1 30
Twelve-to-Pica	5	2 00	9 oz.		1 25

Brass Space Rule, on six-to-pica body, cut by half ems from one to six ems Nonpareil, at \$2.00 per pound.

Price List of Printing Material.

BRONZES—

Various shades, extra fine, per ounce..... \$0 30
 In quantities, per pound, from..... \$2 00 to 5 00

BRONZING PADS—

Elm City Bronzer..... 2 50

BRUSHES, LYE—

Tampeco..... 35
 Bristle..... 50

CABINETS—

Stained. **Blank. Regular.**

With 12 cases, two-thirds job, flat top \$10 00 12 00
 " 16 " " " " " 12 00 15 00
 " 20 " " " " " " 15 00 18 00
 " 12 " full job, triple, flat top 14 00 18 00
 " 16 " " " " " " 16 00 22 00
 " 20 " " " " " " 18 00 25 00
 Galley top, \$4 00 additional each.

Cherry.

12 cases, two-thirds Job, galley top 21 50
 16 " " " " " " 26 50
 18 " " " " " " 30 50
 20 " " " " " " 34 50
 Combination No. 1, Black Walnut..... 85 00
 " No. 2, " " 65 00
 Eagle 80 00
 California 60 00
 Bracket Cabinet, 18 two-third cases 35 00
 " " 18 three-quarter cases 40 00
 " " 18 full cases 43 00

CABINET, INK—

With four compartments for ink, and marble top, 18x24 13 00

CARD CUTTERS—

Elm City, 12-inch shear, cuts full board 10 00
 Improved No. 1, rotary 30 00
 " No. 2, " 45 00

CASES—

News, plain, per pair 1 60
 " (patented) " 1 75
 Job or Italic, plain, each 90
 " " (patented) " 1 00
 Triple, plain, " 90
 " (patented) " 1 00
 Figure 1 00
 Quad and Space 1 00
 Labor-Saving Lead and Slug 1 00
 " " Rule 1 15
 Blank, full size 65
 " two-thirds size 45
 Two-thirds pairs, upper and lower, per pair 1 40
 " Job or Italic, each 75
 Portable Sort Case—single, 65 cents; double 90

CHASES—Book—

SKELETON.

Inside Measure.	Outside Measure.	Each.
19 ³ / ₄ x 27 ¹ / ₂	22 ¹ / ₄ x 30	5 50
21 ³ / ₄ x 32 ¹ / ₂	24 ¹ / ₂ x 35	6 00
23 ³ / ₄ x 37	26 ¹ / ₄ x 39 ¹ / ₂	7 00
25 ³ / ₄ x 41 ¹ / ₂	28 ¹ / ₄ x 44	8 00
27 ¹ / ₂ x 46	30 ¹ / ₂ x 49	9 50
29 ¹ / ₂ x 50 ¹ / ₂	32 ¹ / ₂ x 53 ¹ / ₂	11 00

WITH ONE CROSS-BAR.

19 ³ / ₄ x 27 ¹ / ₂	22 ¹ / ₄ x 30	7 00
21 ³ / ₄ x 32 ¹ / ₂	24 ¹ / ₄ x 35	7 50
23 ³ / ₄ x 37	26 ¹ / ₄ x 39 ¹ / ₂	8 50
25 ³ / ₄ x 41 ¹ / ₂	28 ¹ / ₄ x 44	9 50
27 ¹ / ₂ x 46	30 ¹ / ₂ x 49	11 00
29 ¹ / ₂ x 50 ¹ / ₂	32 ¹ / ₂ x 53 ¹ / ₂	12 50

WITH SHIFTING BARS.

19 ³ / ₄ x 27 ¹ / ₂	22 ¹ / ₄ x 30	9 50
21 ³ / ₄ x 32 ¹ / ₂	24 ¹ / ₄ x 35	10 00
23 ³ / ₄ x 37	26 ¹ / ₄ x 39 ¹ / ₂	10 50
25 ³ / ₄ x 41 ¹ / ₂	28 ¹ / ₄ x 44	11 50
27 ¹ / ₂ x 46	30 ¹ / ₂ x 49	13 00
29 ¹ / ₂ x 50 ¹ / ₂	32 ¹ / ₂ x 53 ¹ / ₂	15 00

CHASES—CONTINUED.

News.

	Inside Measure of Each Half.	Outside Measure over all.	Per Pair.
5-Column Folio	12 ³ / ₄ x 20	20 ¹ / ₂ x 22 ¹ / ₂	\$9 00
6 " "	15 x 21 ³ / ₄	34 x 24 ¹ / ₄	10 00
7 " "	17 x 23 ³ / ₄	38 ¹ / ₂ x 26 ¹ / ₄	11 00
8 " "	19 ¹ / ₂ x 25 ³ / ₄	43 x 28 ¹ / ₄	12 00
9 " "	21 ³ / ₄ x 27 ³ / ₄	47 ¹ / ₂ x 30 ¹ / ₄	13 00
10 " "	24 x 29 ³ / ₄	52 x 32 ³ / ₄	15 00
4 " Quarto	16 x 22	36 ¹ / ₂ x 24 ¹ / ₂	12 00
5 " "	19 ¹ / ₂ x 26 ¹ / ₂	43 ¹ / ₂ x 28 ¹ / ₂	13 00
6 " "	21 ¹ / ₂ x 30 ¹ / ₂	47 ¹ / ₂ x 33	15 00
7 " "	23 ³ / ₄ x 35	52 x 38	17 00

Other sizes made to order. Steel Chases at an advance of twenty-five per cent.

Cast Iron, Extra Heavy Finish.

	Inside.		Inside.	
Card.....	4 x 5	\$0 40	Job.....	10 x 14 1 30
".....	4 ¹ / ₄ x 6	50	".....	14 x 17 1 50
".....	5 x 7	70	".....	18 x 24 2 00
Bill-Head	6 x 8	80	Program.	5 x 16 ¹ / ₂ 1 00
".....	8 x 10	1 00	".....	8 x 23 ¹ / ₂ 1 40
Job.....	9 x 12	1 15		

Other sizes made to order.

For Nonpareil Presses.

Inside.		Inside.	
7 ¹ / ₂ x 12	\$1 50	10 ³ / ₄ x 15 ³ / ₄	1 75
10 x 16	1 80	12 x 17	2 00
15 x 19	2 25	17 x 24, cast	2 75
15 x 25	2 50	17 x 24, wrought	4 00
9 x 12	1 50		

For Reliable Presses.

8³/₄ x 15³/₄ inside, cast, each 1 50
 11 x 15 " " " 1 75

CHICKEN FOOT—

Each..... 75

CIRCULAR QUADS—

Font of eight sets..... 3 50

COLUMN RULES—

Nonpareil body, per inch..... 2¹/₂

COMPOSITION—See ROLLER COMPOSITION.

Composition Kettles according to size and material \$3 50 to 15 00

COMPOSING RULES—

News measure 25
 Book " 30 to 50

COMPOSING STICKS—

Screw Stick, 6 inches 75
 Each additional two inches 15
 German Silver Composing Stick, 6 inches 1 50
 Grover's Patent, 6 inches 1 10
 Each additional two inches 20
 24-inch Mahogany Job Stick 1 10
 30 " " " " 1 25
 36 " " " " 1 50

COUNTING MACHINES—

Hart's No. 2, counts 10,000 8 00
 " No. 3, " 100,000 10 00
 " No. 4, " 100,000, extra finish 12 00
 Elm City, counts 100,000 10 00
 Imp. Registering Machine—No. 1 counts 10,000, 5 00
 " " " " 2 " 100,000, 10 00
 " " " " 3 " 1,000,000, 12 00

COUNTERSHAFTS, PULLEYS, ETC. See PULLEYS.

CROSS COLUMN RULES—

Double, each 6
 Parallel 6

CURVING MACHINE—

Golding's 10 00
 Square Die, \$1.00 extra.

Price List of Printing Material.

DASH RULES—	
Single and Wave, each.....	40 07
Double and Parallel, each.....	8
DATE LINES—	
Electrotyped.....	50
ELECTROTYPING in all its branches. Estimates on cuts, bookwork, etc., furnished on application.	
ENGRAVING ON WOOD. Estimates furnished.	
ENGRAVER'S TOOLS—	
Per set of six tools.....	2 50
ENGRAVER'S WOOD—	
Box, per square inch.....	5
Maple, per square inch.....	3
ENGINES, NILES—	
Four Horse-power, 4x5.....	400 00
Six " " 6x7.....	550 00
Eight " " 6x7.....	650 00
Ten " " 7x9.....	850 00
Twelve " " 8x9.....	1,000 00
FIGURE SLUGS—	
Cast, cut to measure, each.....	10
FLY STICKS—	
Per dozen.....	1 50
FOOT SLUGS—	
Beveled, metal, each.....	5
FRISKETS—	
For Hand-Presses.....	\$3 00 to 5 00
FURNITURE AND REGLET, CHERRY—	
Nonpareil to Three-Line Nonpareil, per yard..	3
Two-Line to Five-Line Pica, per yard.....	4
Larger and Beveled Side-Sticks.....	
GALLEYS, PATENT LINED—	
Job Gallies, brass lined . 6 x10 inches.....	2 00
" " " " 8 3/4 x13 ".....	2 50
" " " " 10 x16 ".....	3 00
" " " " 12 x18 ".....	3 50
" " " " 14 x20 ".....	4 00
" " " " 15 x22 ".....	5 00
Wilson's Patent Galley, 10x15.....	4 50
Mailing Gallies of any size made to order.	
News Galley, all brass, single.....	2 50
" " " " double.....	3 50
" " " " single column, brass lined.....	2 00
" " " " double " ".....	2 50
" " " " single " " not lined.....	1 50
" " " " double " ".....	2 00
Slice Gallies, 6x10 inches.....	2 00
" " 10x16 ".....	2 50
" " 16x22 ".....	4 00
Wood, 6x18 ".....	30
" " 8x20 ".....	40
GALLEY RACKS—	
For 6 Gallies.....	\$3 00
For 12 Gallies.....	6 00
" 8 ".....	4 00
" 15 ".....	7 50
" 10 ".....	5 00
" 20 ".....	10 00
GLASS INK SLABS. See INK SLABS.	
GREEK TYPE—	
Brevier, 10 A, 50 a.....	6 40
Long Primer, 10 A, 50 a.....	7 50
GAUGE PINS, MEGILL'S PATENT—	
No. 1, Pica high, per dozen.....	60
No. 2, English high, ".....	60
No. 3, Great Primer high, ".....	60
No. 4, Pica high, no lip, ".....	60
Patent Spring Tongue, ".....	1 20
Extension, per pair, ".....	1 00
Wire Gauge Pins, ".....	25
HAND-PRESSES. See PRESSES.	
HEAD RULES—	
Nonpareil body, per inch.....	2 1/2

HEBREW TYPE—	
Long Primer, 25 A.....	\$3 00
Pica, 15 A.....	2 40
Two-Line English, 5 A.....	3 40
IMPOSING RULES—	
News.....	30
IMPOSING STONES—	
Marble, double sawed, 2 in. thick, without stand—	
24x36.....	6 00
30x60.....	12 50
30x72.....	15 00
30x84.....	17 50
30x90.....	18 75
Other sizes at \$1 00 per square foot.	
Stands, \$5 00 and upward, according to material and finish.	
INK—	
News ink, in 10-pound cans, per lb.....	16
" " in kegs, 25 lbs., ".....	12
" " " 50 lbs., ".....	11
" " " 100 or 200 lbs., ".....	10
" " in barrels, 400 lbs.....	8
Book Ink, fine.....	25, 40, 50
Job Ink, for dry and calendered paper, will not set off.....	50, 75, 1 00
Special quick-drying Black.....	1 00
Superfine quick-drying Black.....	1 50
Extra Super quick-drying Ink.....	2 00
Extra fine Cut Ink.....	3 00
Wood Cut Ink.....	5 00
Gold Size.....	\$1 00, \$1 50, 2 00
White Size, for dry colors.....	1 50
Ultramarine Ink.....	50, 75, \$1 00, \$1 50, 2 00
Light and Dark Blue.....	75, \$1 00, \$1 50, 2 00
Blue and Green Poster Ink.....	50
Light and Dark Green.....	75, \$1 00, \$1 50, \$2 00
Red Poster Ink.....	50
Fine Red, for paper.....	\$2 00, 3 00
Extra fine Red.....	\$5 00, 10 00
Lake Ink.....	10 00
Scarlet Red.....	\$3 00 to 5 00
Cardinal Red.....	\$8 00 to 10 00
Crimson Lake.....	\$3 00 to 5 00
Red Copying.....	5 00
Light and Dark Brown.....	\$1 00, \$1 50, 2 00
Carmine Ink, per oz.....	2 00
Purple Ink, ".....	2 00
Bronzes of every shade, per oz.....	30
White Ink.....	50, 1 00
Lemon and Orange Yellow.....	\$1 00, 2 00
Emerald Green.....	3 00
Varnish, No. 1 and 0.....	55
Gloss Varnish.....	1 00
Special prices given on Book and Job Inks in large quantities. High-priced inks furnished in half-pound and quarter-pound cans, if desired.	
INK CABINETS. See CABINETS.	
INK FOUNTAIN, SHORT—	
For Nonpareil Press.....	10 00
INKING APPARATUS, for Hand-Press—	
SINGLE CYLINDER WITH TWO ROLLERS.	
32-in., 6 col. folio.....	\$30 00
36 " 7 " ".....	32 50
42-in., 8 col. folio.....	35 00
46 " 9 " ".....	37 50
SINGLE VIBRATING CYLINDER WITH TWO ROLLERS.	
32-in., 6 col. folio.....	40 00
36 " 7 " ".....	42 50
42-in., 8 col. folio.....	45 00
46 " 9 " ".....	47 50
ROLLER FRAME FOR SINGLE CYLINDER.	
32-in., 6 col. folio.....	8 00
36 " 7 " ".....	10 00
42-in., 8 col. folio.....	12 00
46 " 9 " ".....	14 00
DOUBLE CYLINDER WITH ONE ROLLER.	
32-in., 6 col. folio.....	21 00
36 " 7 " ".....	22 00
42-in., 8 col. folio.....	26 00
46 " 9 " ".....	28 00
ROLLER FRAME FOR DOUBLE CYLINDER.	
32-in., 6 col. folio.....	5 00
36 " 7 " ".....	6 00
42-in., 8 col. folio.....	7 00
46 " 9 " ".....	8 00

Price List of Printing Material.

INK KNIFE—	
6-inch blade..... 45	9-inch blade..... \$0 95
7 " "..... 65	12 " "..... 1 45
INK SLABS—	
Marble, per square foot.....	80
Glass, " " ".....	75
IRON FURNITURE—	
Beveled, per inch.....	4
IRON MITER BOXES—	
Each.....	3 00
ITALIC—	
Same prices as Roman, when ordered with it.	
JOB PRESSES. See PRESSES.	
KNIVES for Paper Cutters furnished and ground.	
LABOR-SAVING FURNITURE—	
Cherry, per Font, 500 pieces, with case.....	8 00
" " 1120 " " ".....	15 00
Metal, in fonts of 10, 25, 50, or 100 lbs., per lb.....	25
LABOR-SAVING RULE. See BRASS RULE.	
LAMP-HOLDERS—	
Each.....	75
Per half dozen.....	3 00
LEAD CUTTERS—	
Barth's Patent Reversible Knife.....	4 00
Common.....	2 50
Little Giant Lead and Rule Cutter.....	8 00
LEADS AND SLUGS—	
Accurately shaved, in strips; cut to measure at an advance of one cent per pound.	
Leads, 6-to-pica and larger, per lb.....	15
" 8-to-pica, ".....	28
" 10-to-pica, ".....	56
" 12-to-pica, ".....	70
" Labor-Saving, 6-to-pica or larger, per lb.....	25
Lead and Slug Rack.....	2 00
LEAD MOULDS—	
Each.....	10 00
LEADERS at price of Roman; not included in fonts unless specially ordered.	
LETTER SLUGS—	
For compositor's take, each.....	10
LYE BRUSHES. See BRUSHES.	
MAILING MACHINES—	
Times Mailer.....	30 00
Piner's Mustang Mailer.....	10 00
Day's Mailer.....	5 00
Galleys for Mustang Mailer, each.....	50
Mailing Type, Dates, etc., furnished to order.	
MAKE-UP RULES, STEEL—	
News.....	30
MALLETS—	
Lignum Vitæ.....	50
METAL FURNITURE. See LABOR-SAVING FURNITURE.	
MITER BOX—	
Wood.....	50
Iron.....	3 00
MITERING MACHINE—	
Universal Rule Shaper.....	25 00
Upright Mitering Machine.....	18 00
Rotary Mitering Machine.....	15 00
MITERING SAW—	
Stiff back, each.....	1 50
MUSIC—	
Excelsior, 25 lbs... \$93 60	Agate, 30 lbs..... 72 00
Diamond, 30 lbs... 96 00	Nonp. No. 3, 60 lbs. 120 00
NEWS INKS. See INKS.	
NONPAREIL PRESS. See PRESSES.	
NOVELTY PROOF PRESS. See PROOF PRESSES.	

OILERS—	
Tin..... \$0 15	Malleable Iron..... \$0 50
Zinc..... 25	Rubber..... 50
OLD MATERIAL taken in exchange for new at list prices.	
Type and Brass Rule, per lb.....	08
Leads, ".....	5
Electro-Plates, ".....	4
Stereo-Plates, ".....	5
Freight deducted.	
Mark the boxes containing old type with your name and our address; weigh them, take freight receipt, and send us duplicate.	
PADDING BOX—	
Cott's.....	2 50
Golding's, 2,000 sheets, 6x12.....	7 50
" 5,000 " 8x16.....	14 00
PAPER CUTTERS—	
Champion, 30-inch, Rotary.....	300 00
" 32 " ".....	350 00
" 36 " ".....	500 00
" 44 " ".....	900 00
Steam Fixtures extra.....	25 00
Clipper, 12-inch, lever.....	40 00
Gem, 30-inch, lever.....	150 00
Leader, 23-inch.....	115 00
" 28-inch.....	170 00
" 30-inch.....	175 00
" 32-inch.....	215 00
Paragon, 22½-inch, lever.....	80 00
" 25 " ".....	110 00
Peerless, 30-inch, front lever.....	175 00
Plow, 28-inch.....	40 00
Printer's, 30-inch, lever, B Style.....	150 00
Sanborn's '87, 25-inch.....	115 00
" " 32-inch.....	150 00
Undercut, 12-inch, lever.....	40 00
" 24-inch, ".....	85 00
" 28-inch, ".....	115 00
" 25-inch, improved.....	150 00
" 30-inch, ".....	175 00
" 30-inch, power.....	500 00
" 34-inch, ".....	600 00
PATTERN LETTERS, ROMAN—	
¼ inch to 5-16 inch, each.....	2
¾ " to 1½ " ".....	2½
9-16 " to 5/8 " ".....	3
¾ inch, 3½ cts.; ¾ inch, 4 cts.; 1 inch, 4½ cts.; 1¼ inch, 6 cts.; 1½ inch, 7½ cts.; 2 inch, 9 cts.	
ROUND-FACE GOTHIC:	
¼ inch, 2 cts.; ¾ inch, 2½ cts.; 1½ inch, 2½ cts.; 5/8 inch, 3 cts.; ¾ inch, 3½ cts.	
ROMAN, BRAND:	
¼ inch, 3 cts.; ¾ inch, 3 cts., ½ inch, 4 cts.; 5/8 inch, 5 cts.; ¾ inch, 6 cts.	
PERFORATING MACHINES—	
Round Hole, 20-inch.....	75 00
" 24 ".....	100 00
" 28 ".....	125 00
PERFORATING RULE—	
Brass, per foot..... \$ 0 25	Steel, per foot..... 75
Cut in labor-saving lengths to order.	
PIECE FRACTIONS—	
Nonpareil, per font \$5 00	L. Primer, per font 3 50
Minion, " 5 00	Small Pica, " 3 30
Brevier, " 3 60	Pica, " 3 00
Bourgeois, " 3 60	Great Primer, " 3 25
PLANERS—	
Mahogany.....	30
" with leather top.....	40
" curved.....	75
" proof.....	50
" " with leather top.....	60
Jones' Pat. Rocking Proof Planer, 3½x10 in.....	1 50
" " " " 7 x12 in.....	2 50

Price List of Printing Material.

POINTS—

For Hand-Presses, per pair \$ 0 50

PRESSES—Army—

6-column folio, 14³/₈×21, complete 60 00
 7 " " 16³/₈×23³/₄, " 85 00
 8 " " 19 ×25, " 120 00
 5 " quarto, 19¹/₂×26, " 125 00

Chromatic Cylinder.

Bed, 22¹/₄×37 inches 1,800 00
 Same press for one color printing. 1,300 00

Cincinnati Cylinder.

RACK AND SCREW DISTRIBUTION.		
Bed.	Largest form printed.	Price.
28×40 inches	24×36 inches	1,000 00
31×46 " "	27×42 " "	1,350 00
34×52 " "	30×40 " "	1,600 00

Boxing and Shipping, \$25 to \$40.

Each press furnished with tapes, blankets, moulds, etc.

TABLE DISTRIBUTION, HAND TURNING.

Bed.	Largest form printed.	Price.
28×40 inches	24×36 inches	900 00
29×43 " "	24×39 " "	1,000 00
33×48 " "	29×44 " "	1,100 00

Boxing, \$25 to \$40. Steam Fixtures Extra.

Each press furnished with tapes, blanket and cast rollers.

Extra Heavy Job Cylinder.

TWO ROLLERS.

17 ×21 ¹ / ₂ inches	1,000 00
22 ¹ / ₄ ×37 " "	1,500 00
32 ×46 " "	2,200 00
33 ×48 " "	2,500 00

Stop Cylinder.

CINCINNATI TYPE FOUNDRY.

Bed.	Size of form.	Rollers.	Price.
18 ¹ / ₄ ×24 inches	14 ¹ / ₂ ×20 ¹ / ₂ inches	4	2,400 00
23 ×28 " "	19 ×24 " "	4	3,000 00
25 ¹ / ₄ ×35 " "	21 ¹ / ₂ ×31 " "	4	3,450 00
32 ×46 " "	26 ×42 " "	4	4,600 00
38 ¹ / ₂ ×52 " "	32 ×48 " "	6	5,900 00

Boxing and Shipping included.

Each press is furnished with blankets, moulds, cones and counter-shaft.

Washington Hand Press.

PLAIN.

Platen.	Bed.	Prints.	Price.
23×31 in.	25 ³ / ₄ ×34 ³ / ₄ in.	6 col. folio.	200 00
23×35 in.	26 ¹ / ₂ ×39 ¹ / ₂ in.	7 col. folio	250 00
25×39 in.	28 ¹ / ₂ ×43 ¹ / ₂ in.	8 col. fol., 5 col. quar.	275 00
27×43 in.	31 ¹ / ₂ ×48 in.	9 col. folio	275 00

PATENT ROLLING BED.

23×35 in.	26 ¹ / ₂ ×39 ¹ / ₂ in.	7 col. folio	250 00
25×39 in.	28 ¹ / ₂ ×43 ¹ / ₂ in.	8 col. fol., 5 col. quar.	275 00
27×43 in.	31 ¹ / ₂ ×47 ¹ / ₂ in.	9 col. folio	300 00
29×43 in.	33 ×48 in.	6 col. quarto	325 00

Boxing included.

Two pairs of points, one wrench, one sheep's foot, pair of bearers, and one extra frisket, go with each press.

PRESSES, JOB—

Chromatic Bag Printing Press.

Platen, 10 ×16	350 00
" 15 ¹ / ₂ ×25	600 00
" 15 ¹ / ₂ ×25, plain	500 00

Boxing and drayage included.

Gordon Job Press.

Eighth Medium—8×12 inside chase	225 00
" " 9×13 " "	250 00
Quarto Medium—10×15 " "	300 00
" " 11×17 " "	350 00
Half Medium—13×19 inside chase	400 00
Steam Fixtures, extra.	15 00
Ink Fountain.	25 00

Boxing, \$6 00, \$7 00, \$10 00.

Monumental Job Press.

6×9 inside chase	\$80 00
8×12 " "	135 00

Boxing included.

Nonpareil Press.

PLATE DISTRIBUTION.

Quarter Folio—9×12 inside chase, with treadle, including Receding Bed	\$225 00
Pulleys for power	10 00
Fountain	10 00
Half Folio—12×17 inside chase, with treadle, including Receding Bed	325 00
Pulleys for power	15 00
Fountain	10 00
10 ³ / ₄ ×15 ³ / ₄ , with Long Fountain and treadle	325 00
Pulleys for power	15 00
Folio—17×24 inside chase, with long fountain and treadle	500 00
Pulleys for power	25 00
Hand Crank	15 00

Boxing included.

Each press is furnished with mould, three chases, and double set of cores.

Pearl Press.

5×8, on Iron Cabinet	70 00
7×11, " "	110 00

Peerless Job Press.

Eighth Medium—8×12 inside chase	225 00
" " 9×13 " "	250 00
Quarto Medium—10×15 " "	300 00
" " 11×16 " "	350 00
Half Medium—14×19 " "	400 00
" " 17×20 " "	450 00
Steam Fixtures, extra.	15 00
Fountain	25 00

Boxing, \$6 00, \$7 00, \$10 00.

Reliable Job Press.

8 ³ / ₄ ×12 ³ / ₄ inside of chase	180 00
11×15 " "	225 00

Boxing included.

United States Job Press.

6×9 ³ / ₄ inside chase	55 00
8×12 " "	75 00
10×15 " "	150 00

Including boxing and cast rollers.

Universal Job Press.

Eighth Medium—7×11 inside chase	200 00
Quarto Medium—10×15 " "	275 00
Half Medium—13×19 " "	375 00
Half Super Royal—14×22 inside chase	450 00
Steam Fixtures, extra	15 00
Ink Fountain	25 00

Boxing included.

PROOF PRESSES

Novelty, 9-inch	4 50
Roller—8 ¹ / ₄ ×28 inches, without stand	20 00
" " " with wood stand	28 00
" " " with iron stand	35 00
" 8 ¹ / ₄ ×29 ¹ / ₂ " without stand	24 00
" " " with wood stand	32 00
" " " with iron stand	39 00
" 16 ¹ / ₄ ×31 ³ / ₈ " without stand	30 00
" " " with wood stand	40 00
" " " with iron stand	50 00
" 20 " " without stand	45 00
" " " with wood stand	65 00
" 22 ¹ / ₂ ×39 ¹ / ₂ " with iron stand	70 00
" " " " and	
movable bearers	125 00

PULLEYS, SHAFTING, ETC.—

Wrought Iron Turned Shafting.

Diameter of Shaft.	Price per Foot.	Diameter of Shaft.	Price per Foot.	Diameter of Shaft.	Price per Foot.
1 3-16 in	\$0 45	2 3-16 in	\$1 06	3 3-16 in	\$2 18
1 7-16 in	55	2 7-16 in	1 30	3 7-16 in	2 56
1 11-16 in	70	2 11-16 in	1 53	3 11-16 in	3 75
1 15-16 in	87	2 15-16 in	1 86		

Price List of Printing Material.

PULLEYS, SHAFTING, ETC.—CONTINUED.

Prices of Pulleys, Bored, Turned and Balanced, with Set Screws or Key Seat.

Dia.	Face.	Price.	Dia.	Face.	Price.	Dia.	Face.	Price.
6	3 1/2	\$2 00	16	10 1/2	\$7 15	30	16 1/2	\$26 17
6	4 1/2	2 27	16	12 1/2	8 26	30	18 1/2	30 00
6	5 1/2	2 54	17	3 1/2	3 88	30	20 1/2	30 00
6	6 1/2	2 81	17	4 1/2	4 31	32	6 1/2	12 19
6	8 1/2	3 10	17	5 1/2	4 74	32	8 1/2	15 34
7	3 1/2	2 15	17	6 1/2	5 17	32	10 1/2	18 49
7	4 1/2	2 42	17	8 1/2	6 35	32	12 1/2	21 64
7	5 1/2	2 69	17	10 1/2	7 53	32	14 1/2	24 79
7	6 1/2	2 96	17	12 1/2	8 71	32	16 1/2	28 14
7	8 1/2	3 23	18	3 1/2	4 01	32	20 1/2	30 00
8	3 1/2	2 42	18	4 1/2	4 44	34	6 1/2	12 97
8	4 1/2	2 57	18	5 1/2	4 87	34	8 1/2	16 22
8	5 1/2	2 84	18	6 1/2	5 50	34	10 1/2	19 47
8	6 1/2	3 11	18	8 1/2	6 65	34	12 1/2	22 72
8	8 1/2	3 38	18	10 1/2	7 92	34	14 1/2	25 97
8	10 1/2	3 65	18	12 1/2	9 19	34	16 1/2	30 13
9	3 1/2	2 53	19	3 1/2	4 29	34	20 1/2	30 00
9	4 1/2	2 76	19	4 1/2	5 03	36	4 1/2	11 50
9	5 1/2	2 99	19	5 1/2	5 37	36	6 1/2	13 60
9	6 1/2	3 22	19	6 1/2	6 42	36	8 1/2	17 18
9	8 1/2	3 69	19	8 1/2	7 64	36	10 1/2	20 76
9	10 1/2	4 16	19	10 1/2	8 58	36	12 1/2	24 34
9	12 1/2	4 63	19	12 1/2	9 52	36	14 1/2	27 92
10	3 1/2	2 65	20	3 1/2	4 77	36	16 1/2	32 47
10	4 1/2	2 90	20	4 1/2	5 32	36	18 1/2	36 17
10	5 1/2	3 15	20	5 1/2	5 87	36	20 1/2	40 68
10	6 1/2	3 40	20	6 1/2	7 00	36	22 1/2	44 68
10	8 1/2	3 98	20	8 1/2	7 88	38	8 1/2	18 85
10	10 1/2	4 62	20	10 1/2	9 47	38	10 1/2	22 62
10	12 1/2	5 26	20	12 1/2	11 06	38	12 1/2	26 59
11	3 1/2	2 84	20	14 1/2	12 65	38	14 1/2	30 56
11	4 1/2	3 07	22	3 1/2	5 10	38	16 1/2	35 28
11	5 1/2	3 30	22	4 1/2	5 72	38	20 1/2	40 00
11	6 1/2	3 54	22	5 1/2	6 36	40	4 1/2	13 21
11	8 1/2	4 28	22	6 1/2	7 00	40	6 1/2	16 48
11	10 1/2	5 03	22	8 1/2	8 56	40	8 1/2	19 85
11	12 1/2	5 78	22	10 1/2	10 32	40	10 1/2	24 06
12	3 1/2	2 98	22	12 1/2	12 08	40	12 1/2	28 57
12	4 1/2	3 24	22	14 1/2	13 84	40	14 1/2	33 08
12	5 1/2	3 50	24	3 1/2	5 41	40	16 1/2	37 67
12	6 1/2	3 86	24	4 1/2	6 13	40	20 1/2	46 31
12	8 1/2	4 60	24	5 1/2	6 85	42	6 1/2	16 61
12	10 1/2	5 45	24	6 1/2	7 57	42	8 1/2	21 22
12	12 1/2	6 30	24	8 1/2	9 30	42	10 1/2	25 83
13	3 1/2	3 12	24	10 1/2	11 21	42	12 1/2	30 44
13	4 1/2	3 42	24	12 1/2	13 12	42	14 1/2	35 05
13	5 1/2	3 72	24	14 1/2	15 00	42	16 1/2	40 18
13	6 1/2	4 04	24	16 1/2	17 53	42	20 1/2	48 00
13	8 1/2	4 96	24	18 1/2	20 85	44	6 1/2	22 55
13	10 1/2	5 85	26	4 1/2	7 00	44	8 1/2	27 70
13	12 1/2	6 74	26	5 1/2	7 64	44	10 1/2	32 85
14	3 1/2	3 32	26	6 1/2	8 28	44	12 1/2	38 00
14	4 1/2	3 65	26	8 1/2	10 15	44	14 1/2	43 15
14	5 1/2	3 98	26	10 1/2	12 36	44	16 1/2	48 30
14	6 1/2	4 31	26	12 1/2	14 57	44	20 1/2	56 45
14	8 1/2	5 28	26	14 1/2	16 78	46	6 1/2	24 34
14	10 1/2	6 21	28	16 1/2	19 09	46	8 1/2	30 11
14	12 1/2	7 22	28	18 1/2	21 80	46	10 1/2	36 00
15	3 1/2	3 47	28	6 1/2	9 65	46	12 1/2	41 65
15	4 1/2	3 82	28	8 1/2	11 88	46	14 1/2	47 80
15	5 1/2	4 17	28	10 1/2	14 51	46	16 1/2	53 95
15	6 1/2	4 52	28	12 1/2	17 14	46	20 1/2	62 10
15	8 1/2	5 62	28	14 1/2	19 77	48	6 1/2	21 97
15	10 1/2	6 68	30	16 1/2	22 80	48	8 1/2	25 73
15	12 1/2	7 74	30	18 1/2	26 33	48	10 1/2	32 22
16	3 1/2	3 72	30	6 1/2	11 35	48	12 1/2	38 71
16	4 1/2	4 10	30	8 1/2	13 73	48	14 1/2	45 20
16	5 1/2	4 48	30	10 1/2	16 77	48	16 1/2	51 69
16	6 1/2	4 86	30	12 1/2	19 81	48	20 1/2	60 18
16	8 1/2	6 04	30	14 1/2	22 85	50	6 1/2	24 34

Ball and Socket Adjustable Hangers.

WITHOUT OIL FOUNTAIN.

Size Journal.	15-16	1 3-16	1 7-16	1 11-16	1 15-16	2 3-16
Drop 10 inch.	\$3 81					
" 12 "		\$4 62				
" 13 "			\$5 98	\$7 05	\$8 51	\$10 11
" 16 "			6 64	8 03	9 27	10 59
" 19 "					10 11	11 84
" 22 "					10 97	12 74
" 25 "						

Size Journal	2 7-16	2 11-16	2 15-16	3 3-16	3 7-16	3 15-16
Drop 13 inch	\$11 38	\$12 63	\$13 91			
" 16 "	11 87	13 53	14 96	\$17 85		
" 19 "	13 06	14 84	15 78	18 39	\$19 13	\$25 08
" 22 "	14 02	15 26	16 62	18 94	19 90	25 79
" 25 "	15 01	15 88	17 70	20 63	20 87	

PULLEYS, SHAFTING, ETC.—CONTINUED.

Rigid Hangers.

WITHOUT OIL FOUNTAIN. BABBITT BEARINGS.

Size Journal.	15-16	1 3-16	1 5-16	1 7-16	1 11-16	1 15-16
Drop 10 inch	\$4 56	\$4 60	\$4 91	\$4 98	\$5 41	
" 12 "	4 71	4 75	5 13	5 21	5 57	\$7 24
" 14 "					5 77	7 55
" 16 "					5 86	7 85
" 18 "					6 18	9 83
" 21 "						10 44

Size Journal	2 3-16	2 7-16	2 11-16	2 15-16	3 3-16	3 15-16
Drop 12 inch		\$8 00				
" 14 "	\$8 40	8 84	\$9 15	\$11 44		
" 16 "	8 72	9 15	9 45	11 74		
" 18 "	10 09	10 53	10 75	12 50		
" 21 "	10 85	11 58	11 74	13 72		

Rigid Post Hangers.

WITHOUT OIL FOUNTAIN. BABBITT BEARINGS.

1 11-16 inch		2 11-16 inch	\$10 82
1 15-16 "	\$7 00	2 15-16 "	11 58
2 3-16 "	8 40	3 3-16 "	
2 7-16 "	10 21	3 7-16 "	

Ball and Socket Post Hangers.

WITHOUT OIL FOUNTAIN.

1 7-16 inch	\$5 60	2 11-16 inch	11 44
1 11-16 "	7 14	2 15-16 "	12 83
1 15-16 "	8 70	3 3-16 "	14 90
2 3-16 "	9 16	3 7-16 "	16 46
2 7-16 "	10 34	3 15-16 "	20 22

Ball and Socket Counter Hangers.

WITH SHIPPER ARM. WITHOUT OIL FOUNTAIN.

15-16 inch Counter Hanger, 10 inch drop	4 16
1 3-16 "	4 97

PULLEYS, CONE—

3 speeds, 8, 10, and 12 inches, × 2 1/2-inch face, per pair.	12 00
3 speeds, 12, 14, and 16 inches, × 3-inch face, per pair.	18 00
4 speeds, 5 1/4 to 9 3/4 in., × 1 1/4-inch face, per pair.	14 00
4 speeds, 12 to 15 1/4 in., × 3-inch face, per pair.	25 00
5 speeds, 7 to 15 in., × 2 1/2-inch face, per pair.	20 00
4 speeds, 14 to 21 in., × 4-inch face, per pair.	40 00

Split Cone Pulleys.

5 speeds, 7 to 15 inches, × 2 1/2-inch face, each.	16 00
4 " 14 1/2 to 18 1/2 in. × 3 1/2 " " " "	17 50

QUOINS—

Boxwood, per 100.	60
Hempe, No. 1, per doz.	2 50
" No. 2, " " " "	3 00
Key, plain	50
" nickeled.	75
Scott's, No. 1, per doz.	2 00
" No. 2, " " " "	2 00
Key, plain.	35
" nickeled.	50

QUADS AND SPACES—

Pearl to Bourgeois, per font.	75
Long Primer to Paragon, " " " "	40
Double Small Pica to Six-Line Pica, per font.	75

QUOTATION FURNITURE—

Assorted sizes, per pound.	30
----------------------------	----

ROLLERS, CAST—

Rollers for 9 × 12 Nonpareil, each.	50
" 10 1/4 × 15 1/4 " " " "	75
" 12 × 17 " " " "	1 25
" 15 × 25 " " " "	1 50
" 31 × 46 Cin. Cylinder Press, per set	12 00
" 33 × 48 " " " "	17 50
Eighth Medium Rollers, each	50
Quarter " " " "	75
Half " " " "	1 25
Hand Rollers, 3 1/4-in. diam., per running inch.	11

Cores and Boxing extra.

Price List of Printing Material.

ROLLER COMPOSITION—

Van Bibber's Roller Composition, per lb.	\$0 30
Rough and Ready " "	35
Rollers cast, per lb.	35

ROLLER COVERING—

Felt, 2½ inches wide, per bolt of 12 yards	5 00
--	------

ROLLER FRAMES AND CORES—

Frames, with one Core. Extra Core.	
6 and 8-inch, with one handle	\$1 25 40
10-inch, " " "	1 50 50
12 " with two handles	1 75 60
14 " " " "	2 00 70
16 " " " "	2 25 80
18 " " " "	2 50 90

ROLLER MOULDS—

For 9 × 12 Nonpareil Press.	3 00
" 10¾ × 15¾ " "	3 75
" 12 × 17 " "	4 25
" 17 × 24 " "	8 00
" 7 × 12 " "	3 00
" 10 × 16 " "	3 75
" 15 × 19 " "	8 00
" 15 × 25 " "	8 00
" 28 × 40 Cylinder Press, iron, ¾-in. diam.	20 00
" 28 × 40 " " brass, 2 " "	12 50
" 31 × 46 " " iron, ¾ " "	22 00
" 31 × 46 " " brass, 2 " "	13 50
" 33 × 48 " " iron, ¾ " "	25 00
" 34 × 52 " " ¾ " "	25 00
" 34 × 52 " " brass, 2 " "	15 00
Other sizes, cast iron, per inch	40
" " brass, per pound.	60

ROTARY PAPER KNIFE—

Attachment for Cylinder Presses	25 00
---------------------------------	-------

RUBBER BLANKET. See BLANKETS.

SAW—

Stiff back.	1 50
-------------	------

SCREW-DRIVERS—

2-inch blade.	\$0 15	6-inch blade.	35
4 " " "	25	8 " " "	45

SCREW OR MONKEY-WRENCHES—

10-inch.	\$1 00	12-inch	1 50
----------	--------	---------	------

SHAFTING. See PULLEYS, ETC.

SHEEPSFOOT—

For Hand-Press.	1 25
-----------------	------

SHOOTING-STICKS—

Steel.	\$0 60	Brass.	1 50
--------	--------	--------	------

SIDE AND FOOT-STICKS—

Iron, per inch.	4
-----------------	---

SIGNS, ALGEBRAIC—

Per Font.		Per Font.	
Diamond	\$2 25	Bourgeois No. 2	1 75
Agate	1 90	Lg. Primer.	2 00
Nonpareil	2 65	" "	2 65
Minion No. 2	1 95	Small Pica	1 50
Brevier " 1	1 60	Pica	1 65
" " 2	2 00	English	1 40
Bourgeois " 1	1 75		

SIGNS, ALMANAC—

Agate	3 40	Lg. Primer No. 1	3 90
Nonpareil	2 95	" " 2	3 00
Brevier No. 1	4 20	Pica	6 10
" " 2	4 75	" " 2	3 75
" " 3	1 20		

SLUGS. See LEADS AND SLUGS.

STANDS—

Single, without Racks	3 00
" with Racks	3 50
Double, without Racks	3 25
" with Racks	4 00
Double Job, with Double Racks, full size	6 00

STEAM FIXTURES sold with presses do not include overhead fixtures, unless specially mentioned in price list of presses sold. For prices, see PULLEYS.

STEREOTYPE BLOCKS—

4to	4 Blocks	Plate, 9 × 12 inches	\$10 00
8vo	8 " "	" 5 × 8 "	14 00
12mo	12 " "	" 4½ × 6¾ "	16 00
18mo	18 " "	" 3 × 4½ "	24 00
32mo	32 " "	" 2½ × 4 "	28 00
48mo	48 " "	" 2¼ × 3¾ "	42 00

With Rule Border, double price.

With Brass Headpiece, each Block extra.	30
With End Hook, each, extra	75
Ratchet.	1 00

STEREOTYPE TOOLS—

Shaving Machine, improved	160 00
" " rising table, 9-inch	250 00
" " " 14-inch	375 00
Chiseling Machine	100 00
Shooting Boards and Planes, all iron.	35 00

TAPES—

¾ and ½-inch Tapes, 36 yards in bolt	75
⅝-inch Tape	1 00
1 and 1¼-inch Tapes	1 60

TREATISE ON PUNCTUATION. See Books.

TYPAN GAUGE PINS. See GAUGE PINS.

TYPE—

Price, per Pound.

SIZES.	FIRST CLASS.		SECOND CLASS.	THIRD CLASS.
	Fonts of 25 lbs. and upward.	Fonts of less than 25 lbs.		
Diamond	\$1 50	\$2 50	\$2 50	\$3 20
Pearl	1 08	1 80	1 80	2 80
Agate	68	1 44	1 44	2 40
Nonpareil	58	1 16	1 16	2 00
Minion	52	1 00	1 00	1 80
Brevier	48	90	90	1 60
Bourgeois	44	80	80	1 44
Long Primer	42	74	74	1 30
Small Pica	40	70	70	1 22
Pica	38	66	66	1 16
English	38	62	62	1 12
Two-L. Brevier	38	60	60	1 06
3-Line Nonp	38	60	60	1 00
Paragon	38	60	60	94
Dbl. Sm. Pica	38	56	56	90
Dbl. Pica	38	56	56	90
5-Line Nonp	38	56	56	86
3-Line Pica	38	56	56	82
7-Line Nonp	38	54	54	78
Four-Line Pica	38	54	54	72
Five-Line Pica	38	52	52	64
Six-Line Pica	38	52	52	64

FIRST CLASS.—Roman, Italic, Old Style, German, and Quads and Spaces.

SECOND CLASS.—Titles, Two-Line Letter, Condensed, Doric, Aldine, Antiques, Gothics, Clarendons, French Clarendons, Ionics, Law Italic and Roman Card Fonts.

THIRD CLASS.—Ornamental, Shaded, Scripts, etc.

TYPE MEASURE.

Boxwood	\$1 50
Cherry, free	3 00

TYPE WASH—

Per box, in 1 pound boxes	20
" doz. " " "	2 25
" box " 2 " "	30
" doz. " " "	3 25

VARNISH. See INKS.

WOOD ENGRAVING done to order.

WOOD RULE—

Plain, on end wood, per foot.	15
" " side " " yard	12
Star, in labor-saving lengths, on end.	20
Star Corners, per set	25

Price List of Printing Material.

WOOD TYPE—

Price, per Letter.

SIZE.	Class A	Class B	Class C	Class D	Class E
2-line Pica	3c	3c	3c	3c	5c
3 " "	3	3	3	3	6
4 " "	3	3	3	3	6
5 " "	4	3	3	3	7
6 " "	5	3	3	4	8
7 " "	5	4	4	4	8
8 " "	6	4	4	4	9
9 " "	7	5	4	5	10
10 " "	8	5	4	5	11
12 " "	9	5	5	5	12
14 " "	10	6	5	6	13
15 " "	11	7	5	6	14
16 " "	12	7	6	7	15
18 " "	13	8	6	7	16
20 " "	14	9	7	8	17
22 " "	15	10	8	9	18
24 " "	16	11	8	10	20
25 " "	17	12	9	11	21
26 " "	18	13	9	12	22
28 " "	19	14	10	13	23
30 " "	20	15	10	14	24
32 " "	21	16	11	15	25
36 " "	22	17	12	16	26
40 " "	24	18	14	17	27
45 " "	19	16	16	18	28
50 " "	20	18	18	20	30
55 " "	22	20	20	22	32
60 " "	25	22	22	24	34
65 " "	28	24	26	26	38
72 " "	30	26	28	28	40
80 " "	32	28	30	30	44
90 " "	34	30	33	33	48
100 " "	37	32	40	40	50

Scale of Fonts.

3 A Capitals, 75 letters.	3 a Lower Case, 65 letters.
4 A " 106 "	4 a " " 90 "
5 A " 120 "	5 a " " 104 "

Figures, 26 in all.

GERMAN FONTS.

2 A Capitals, 60 letters.	3 a Lower Case, 72 letters.
3 A " 66 "	4 a " " 88 "
4 A " 86 "	5 a " " 106 "

Figures, 22 in all.

Class A.

Antique Extended.	Gothic Extended.
Antique Tuscan Extend.	Gothic Tuscan Extend.
Antique Tuscan Expand.	Roman Extended.
Ant. Light-Face Extend.	Roman Ext. Light-Face.
Aldine Expanded.	Runic Expanded.
Clarendon Extended.	Tuscan Extended.

Class B.

Ætna.	Gothic Cond. No. 1, 2, 3, 4.
Aldine.	Grecian.
Antique.	Grecian Condensed.
Antique Light-Face.	Grecian Cond. No. 1.
Antique Condensed.	Ionic.
Arabesque.	Ionic No. 1.
Bavarian.	Ionic Condensed.
Columbian.	Norwich Aldine.
Clarendon.	Old Style.
Clarendon Condensed.	Old Style Condensed.
Clarendon Light-Face.	Roman.
Clarendon L.-Face Italic.	Roman Condensed.
Gothic.	Roman No. 2.
Gothic Condensed.	Roman Light-Face.

WOOD TYPE—CONTINUED.

Class A.

Gothic Light-Face.	Roman Light-Face No. 1
Gothic Round.	Roman Con. Light-Face.
Gothic Round No. 1.	Runic.
Gothic Round Light-Face.	

Class C.

Antique Extra Condensed.	Egyptian.
Ant. Ex. Cond. Nos. 1, 2, 3.	Egyptian Condensed.
Antique Dbl. Ex. Cond.	French Antique.
Antique Treble Ex. Cond.	French Clarendon.
Antique, Skeleton.	Gothic Cond. No. 1.
Antique Tuscan No. 9.	Goth. Cond. Light-Face.
Ant. Dbl. Ex. Cond. No. 1.	Goth. Ex. Cond. L.-Face.
Belgian.	Gothic Extra Cond.
Clarendon No. 1.	Gothic Ex. Cond. No. 1.
Clarendon Italian.	Gothic Dbl. Extra Cond.
Clarendon Extra Cond.	Gothic Treble Ex. Cond.
Clar., Ex. Cond. Light-Face.	Goth. Round Ex. Cond.
Clarendon Dbl. Ex. Cond.	Gothic Back-Slope.
Clar. Dbl. Ex. Cond. L.-F.	Grecian Extra Cond.
Grecian Dbl. Extra Cond.	Roman Ex. Cond. No. 1.
Mowry Antique.	Roman Ex. Cond. L.-F.
Parisian.	Roman Dbl. Ex. Cond.
Round Clarendon.	Roman Treb. Ex. Cond.
Roman Extra Condensed.	

Class D.

Antique Tuscan.	Egyptian Ornamented.
Antique Tuscan Cond.	Etruscan No. 4.
Antique Tuscan Ex. Cond.	Gothic Tuscan.
Ant. Tuscan Dbl. Ex. Cond.	Gothic Tuscan Cond.
Ant. Tuscan Nos. 1-12.	Gothic Tuscan Ex. Cond.
Ant. Tus. Ex. Cond. No. 5.	Gothic Tuscan Nos. 1-4.
Ant. Tuscan Light-Face.	Gothic Pointed.
Ant. Tus. L.-Face Nos. 1, 2.	Gothic Pointed No. 1.
Athenian.	Gothic Dotted.
Arabian.	German Condensed.
Arabian No. 1.	German Extra Cond.
Arcadian No. 1.	Ionian Condensed.
Armenian.	Italian.
Bulletin Script.	Prussian.
Celtic.	Poster Text.
Celtic No. 2.	Page's Bulletin.
Caxton No. 7.	Teutonic.
Composite Condensed.	Tuscan Italian.

Class E.

Arcadian.	Gothic, Open.
Arcadian Shaded No. 1.	Gothic Cond., Open.
Aldine Ornamented.	Goth., Round, Half Open
Antique Cond., Orna.	Gothic Curved Shade.
Antique Cond. Orna. No. 1.	Gothic Outline Shade.
Ant. Tus. Cond. Shad. No. 1.	Gothic Orna. Nos. 2, 7.
Ant. Tus. Shade Nos. 1, 2.	Goth. Tus. Shade Nos. 1, 3.
Ant. Tuscan Light Shade.	Goth. Tus. Con. L. Shad.
Ant. Tuscan Cond. Open.	Goth. Tus. Ex. Con. Open
Ant. Tus. Cond. O. Shad.	Goth. Tus. Con. O. Shad.
Ant. Tus. Con. O. Shade.	German.
Antique Tuscan Open.	German Full Face.
Ant. Tuscan Open No. 11.	Munich.
Ant. Tus. Ex. Cond. Open.	Ornate No. 1.
Clarendon No. 1, Open.	Phantom Shade.
Clarendon Open Shade.	Roman, Rimmed.
Clarendon Orna. No. 2.	Roman Shade.
Clarendon Shade No. 1.	Rimmed Outline Shade
Clarendon Shade.	Tuscan, Open.
Clarendon Cond. Open.	Tuscan Light Shade.
Double Gothic.	Tuscan Cond. Orna.
Etruscan No. 5.	Tus. Con. Shad. Nos. 1, 2.
Expanded Nos. 4, 6.	Unique.

WRENCHES—

Screw or Monkey, 10-inch.	\$1 00
" " 12 "	1 50

FIRST-CLASS ESTIMATES FOR COUNTRY PAPERS,

With Circulation over 1,000 Weekly.

Standard Measure, 13m Pica.

PRICES CASH, AND SUBJECT TO CONSTANT CHANGE.

ARTICLES.	6-Col. Folio. Size of Paper, 21×31.	7-Col. Folio. Size of Paper, 24×35.	8-Col. Folio. Size of Paper, 26×40.	9-Col. Folio. Size of Paper, 28×44.	4-Col. Quarto. Size of Paper, 22×32.	5-Col. Quarto. Size of Paper, 26×42.	6-Col. Quarto. Size of Paper, 30×44.	7-Col. Quarto. Size of Paper, 33×48.
Country Cylinder Press, Hand-power	\$850 00	\$900 00	\$1,000 00	\$1,100 00	\$900 00	\$1,000 00	\$1,100 00	\$1,700 00
Chases, in halves,	10 00	11 00	12 00	13 00	12 00	13 00	15 00	18 00
Steel Slide and Foot-sticks,	2 75	3 00	3 35	3 75	3 75	4 70	5 40	6 00
Proof Press, 8×28 inches,	20 00	20 00	20 00	20 00	20 00	20 00	20 00	20 00
Single Gallies,	6 12 00	8 16 00	10 20 00	12 24 00	6 12 00	10 20 00	12 24 00	12 24 00
Double Gallies,	1 2 50	1 2 50	2 5 00	2 5 00	1 2 50	2 5 00	2 5 00	2 5 00
Composing Sticks,	4 3 00	6 4 50	7 5 25	8 6 00	4 3 00	5 3 75	6 4 50	7 5 25
Pairs of Cases,	9 14 40	10 16 00	12 19 20	13 20 80	9 14 40	12 19 20	13 20 80	15 24 00
Job and Triple Cases,	16 14 40	20 18 00	20 18 00	20 18 00	16 14 40	20 18 00	20 18 00	20 18 00
Double Stands, with Racks,	3 12 00	4 16 00	5 20 00	6 24 00	3 12 00	4 16 00	5 20 00	6 24 00
Imposing Stone, with Stand,	2×5½ 18 00	2½×6 22 00	2½×7 25 00	3×8 32 00	2×5½ 18 00	2½×7 25 00	3×8 32 00	2 Stones 44 00
Galley Rack,	6 3 00	10 5 00	12 6 00	14 7 00	8 4 00	12 6 00	14 7 00	14 7 00
Mallet, Planer, Shoot'g Stick, Quoin,	2 00	2 00	2 00	2 00	2 00	2 00	2 00	2 00
Lye Brush and Bodkins,	1 00	1 00	1 00	1 00	1 00	1 00	1 00	1 00
News Ink,	50 lbs. 5 50	50 lbs. 5 50	50 lbs. 5 50	50 lbs. 5 50	50 lbs. 5 50	50 lbs. 5 50	50 lbs. 5 50	50 lbs. 5 50
Col. and Head Rules for entire paper,	11 60	16 00	18 80	22 00	10 80	17 60	23 20	32 00
Advertising Rules,	75 3 00	100 4 00	125 5 00	125 5 00	75 3 00	100 4 00	125 5 00	150 6 00
Cross Column Rules,	15 90	20 1 20	20 1 20	25 1 50	15 90	20 1 20	25 1 50	25 1 50
Single Dash Rules,	50 3 50	75 5 25	100 7 00	100 8 00	50 3 50	75 5 25	100 8 00	100 8 00
Double Dash Rules,	50 4 00	75 5 00	100 6 00	100 8 00	50 4 00	75 5 00	100 8 00	100 8 00
Leads and Slugs,	30 lbs. 4 80	40 lbs. 6 40	50 lbs. 8 00	60 lbs. 9 60	30 lbs. 4 80	40 lbs. 6 40	50 lbs. 8 00	60 lbs. 9 60
Composing and Imposing Rules,	5 1 25	7 1 75	8 2 25	9 2 25	5 1 25	6 1 50	7 1 75	8 2 00
Rougecoils,	300 lbs. 132 00	350 lbs. 154 00	400 lbs. 176 00	450 lbs. 198 00	300 lbs. 132 00	400 lbs. 176 00	450 lbs. 198 00	500 lbs. 220 00
Minion,	150 lbs. 78 00	175 lbs. 91 00	200 lbs. 104 00	225 lbs. 117 00	150 lbs. 78 00	200 lbs. 104 00	225 lbs. 117 00	250 lbs. 130 00
Head to Paper,	2 50	2 50	2 50	2 50	2 50	2 50	2 50	2 50
Minion Title No. 4,	1 3 00	1 3 00	2 6 00	2 6 00	1 3 00	2 6 00	2 6 00	2 6 00
Brevier Aldine,	2 5 50	2 5 50	3 8 25	3 8 25	2 5 50	3 8 25	3 8 25	3 8 25
Brevier Gothic No. 2,	1 2 80	1 2 80	2 80	2 80	1 2 80	2 80	2 80	2 80
Brevier Italic Title No. 2,	1 3 25	1 3 25	1 3 25	1 3 25	1 3 25	1 3 25	1 3 25	1 3 25
Brevier Antique Extended No. 3,	1 2 50	1 2 50	1 2 50	1 2 50	1 2 50	1 2 50	1 2 50	1 2 50
Long Primer Ionic,	1 2 25	1 2 25	1 2 25	1 2 25	1 2 25	1 2 25	1 2 25	1 2 25
Pica Modern Antique Condensed,	1 2 75	1 2 75	1 2 75	1 2 75	1 2 75	1 2 75	1 2 75	1 2 75
Pica Clarendon Extended,	1 3 50	1 3 50	1 3 50	1 3 50	1 3 50	1 3 50	1 3 50	1 3 50
Two-Line Minion No. 7,	1 2 50	1 2 50	1 2 50	1 2 50	1 2 50	1 2 50	1 2 50	1 2 50
Two-Line Nonpareil No. 5,	1 1 50	1 1 50	1 1 50	1 1 50	1 1 50	1 1 50	1 1 50	1 1 50
Three-Line Nonp. Modern Ant. Cond.	1 4 00	1 4 00	1 4 00	1 4 00	1 4 00	1 4 00	1 4 00	1 4 00
Three-Line Nonp. Modern Antique,	1 3 90	1 3 90	1 3 90	1 3 90	1 3 90	1 3 90	1 3 90	1 3 90
Three-Line Pica Modern Antique,	1 8 50	1 8 50	1 8 50	1 8 50	1 8 50	1 8 50	1 8 50	1 8 50
Three-Line Pica Modern Ant. Cond.,	1 5 00	1 5 00	1 5 00	1 5 00	1 5 00	1 5 00	1 5 00	1 5 00
Dbl. Paragon Skeleton Antique No. 2,	1 5 50	1 5 50	1 5 50	1 5 50	1 5 50	1 5 50	1 5 50	1 5 50
3-Line Nonp. Modern Antique Wide,	1 3 75	1 3 75	1 3 75	1 3 75	1 3 75	1 3 75	1 3 75	1 3 75
3-Line Nonp. Modern Antique,	1 7 00	1 7 00	1 7 00	1 7 00	1 7 00	1 7 00	1 7 00	1 7 00
Pica Latin Antique,	1 2 95	1 2 95	1 2 95	1 2 95	1 2 95	1 2 95	1 2 95	1 2 95
3-Line Nonpareil Latin Antique,	1 3 75	1 3 75	1 3 75	1 3 75	1 3 75	1 3 75	1 3 75	1 3 75
Double Pica Latin Antique,	1 6 15	1 6 15	1 6 15	1 6 15	1 6 15	1 6 15	1 6 15	1 6 15
3-Line Pica Latin Antique,	1 7 85	1 7 85	1 7 85	1 7 85	1 7 85	1 7 85	1 7 85	1 7 85
Quads and Spaces for display, assorted	4 00	6 00	6 00	6 00	4 00	6 00	6 00	6 00
Total	\$1,304 00	\$1,424 50	\$1,591 70	\$1,757 35	\$1,347 05	\$1,577 50	\$1,748 75	\$2,424 80
Boxing and Shipping.								

The quantity of Type in these estimates is liberal, but very convenient to have in the house. It is possible to get along with much less, where great economy has to be observed.

CINCINNATI TYPE FOUNDRY,
No. 201 Vine Street.

HAND-PRESS NEWSPAPER ESTIMATES FOR COUNTRY PAPERS,

With Circulation of less than 1,000 Weekly.

Prices Net Cash, and subject to Constant Changes.

ARTICLES.	5-Col. Folio. Size of Paper, 20" x 26.	6-Col. Folio. Size of Paper, 22" x 31.	7-Col. Folio. Size of Paper, 24" x 35.	8-Col. Folio. Size of Paper, 26" x 40.	9-Col. Folio. Size of Sheet, 28" x 44.	4-Col. Quarto. Size of Paper, 22" x 32.	5-Col. Quarto. Size of Paper, 26" x 42.	6-Col. Quarto. Size of Paper, 30" x 44.
Washington Hand-Press*	\$175 00	\$200 00	\$250 00	\$250 00	\$275 00	\$200 00	\$250 00	\$300 00
Chases, in halves.	9 00	10 00	11 00	12 00	13 00	12 00	13 00	15 00
Steel Side and Foot-Sticks.	2 40	2 75	3 00	3 35	3 75	3 75	4 70	5 40
Hand Roller Frame and 2 Cores.	14 in. 2 75	3 00	3 25	3 50	4 00	16 in. 3 00	20 in. 3 50	22 in. 4 00
One Roller, Cast.	1 00	1 75	2 00	2 20	2 40	2 00	2 50	2 75
Single Brass Galleys.	3 6 00	4 8 00	6 12 00	8 16 00	10 20 00	4 8 00	8 16 00	10 20 00
Composing Sticks.	3 3 25	4 3 00	5 3 00	5 3 75	6 4 50	4 3 00	6 4 50	8 6 00
Pairs of Cases.	3 4 80	4 4 80	5 4 80	6 4 80	7 11 20	4 6 40	6 9 00	7 11 20
Job and Triple Cases.	7 6 30	7 6 30	10 9 00	10 9 00	10 9 00	7 6 30	10 9 00	10 9 00
Fontble Stands, with Racks.	1 4 00	2 8 00	3 12 00	3 12 00	4 16 00	2 8 00	3 12 00	4 16 00
Imposing Stone and Stand.	2-5 17 00	2-5 18 00	2-5 22 00	2-5 23 00	3-8 32 00	2-5 18 00	2-5 23 00	3-8 32 00
Mallet, Planer, Shoot, Stick, Quoins	2 00	2 00	2 00	2 00	2 00	2 00	2 00	2 00
Lye Brush, Spring Bodkins.	1 00	1 00	1 00	1 00	1 00	1 00	1 00	1 00
News Ink, best, 25 lbs.	3 00	3 00	3 00	3 00	3 00	3 00	3 00	3 00
Column and Head Rules, one side	5 00	5 80	8 00	9 40	11 40	5 40	8 80	10 00
Advertising Rules.	2 00	3 00	3 00	4 00	5 00	3 00	4 00	5 00
Paragon Rules.	10 60	15 90	20 1 20	20 1 20	25 1 20	7 5 90	10 1 20	12 5 00
Single Dash Rules.	5 0 3 50	5 0 3 50	5 5 5 25	5 5 5 25	5 5 5 25	3 20 7 5	5 25 7 00	5 25 7 00
Double Dash Rules.	2 5 2 00	3 0 2 40	4 0 3 20	4 0 3 20	5 0 4 00	4 0 3 20	5 0 4 00	5 0 4 00
Leads and Slugs.	2 0 3 20	2 5 4 00	3 0 4 80	4 0 6 40	5 0 8 00	2 5 4 00	4 0 6 40	5 0 8 00
Composing Rules.	2 50 3 75	3 75 4 00	4 1 00	4 1 00	5 1 25	3 75 4 00	4 1 00	5 1 25
Bourgeois.	100 lbs. 41 00	150 lbs. 65 00	175 lbs. 77 00	200 lbs. 88 00	225 lbs. 99 00	150 lbs. 65 00	200 lbs. 88 00	225 lbs. 99 00
Minton.	50 lbs. 26 00	50 lbs. 26 00	75 lbs. 39 00	100 lbs. 52 00	125 lbs. 65 00	50 lbs. 26 00	100 lbs. 52 00	125 lbs. 65 00
Head to Paper.	2 50	2 50	2 50	2 50	2 50	2 50	2 50	2 50
Minton Title No. 4.	1 3 00	1 3 00	2 6 00	2 6 00	2 6 00	1 3 00	2 6 00	2 6 00
Brevier Aldine.	1 2 75	1 2 75	2 5 50	2 5 50	2 5 50	1 2 75	2 5 50	2 5 50
Brevier Gothic No. 2.	1 3 25	1 3 25	2 6 50	2 6 50	2 6 50	1 3 25	2 6 50	2 6 50
Brevier Italic Title No. 2.	1 2 50	1 2 50	2 5 00	2 5 00	2 5 00	1 2 50	2 5 00	2 5 00
Brevier Antique Extended No. 3.	1 2 25	1 2 25	2 4 50	2 4 50	2 4 50	1 2 25	2 4 50	2 4 50
Long Primer Ionic.	1 2 75	1 2 75	2 5 50	2 5 50	2 5 50	1 2 75	2 5 50	2 5 50
Pica Modern Antique Condensed.	1 2 75	1 2 75	2 5 50	2 5 50	2 5 50	1 2 75	2 5 50	2 5 50
Pica Clarendon Extended.	1 2 75	1 2 75	2 5 50	2 5 50	2 5 50	1 2 75	2 5 50	2 5 50
Two-Line Minton No. 7.	1 2 50	1 2 50	2 5 00	2 5 00	2 5 00	1 2 50	2 5 00	2 5 00
Two-Line Nonpareil No. 5.	1 1 50	1 1 50	2 3 00	2 3 00	2 3 00	1 1 50	2 3 00	2 3 00
Three-Line Nonp. Mod. Ant. Cond.	1 4 00	1 4 00	2 8 00	2 8 00	2 8 00	1 4 00	2 8 00	2 8 00
Three-Line Nonp. Modern Ant.	1 3 90	1 3 90	2 7 80	2 7 80	2 7 80	1 3 90	2 7 80	2 7 80
Three-Line Pica Modern Antique.	1 8 50	1 8 50	3 7 00	3 7 00	3 7 00	1 8 50	3 7 00	3 7 00
Three-Line Pica Mod. Ant. Cond.	1 5 00	1 5 00	3 0 00	3 0 00	3 0 00	1 5 00	3 0 00	3 0 00
Dbl. Paragon Skeleton Ant. No. 2.	1 5 50	1 5 50	3 1 00	3 1 00	3 1 00	1 5 50	3 1 00	3 1 00
Quads and Spaces for display.	2 50	2 50	5 00	5 00	5 00	2 50	5 00	5 00
Total on Auxiliary Plan	\$968 40	\$128 05	\$524 65	\$592 35	\$666 40	\$133 45	\$584 15	\$695 25
Boxing and shipping.								
To print entire paper, add:	2 50	4 00	4 00	4 70	5 70	2 70	4 40	5 00
Col. and Head Rules for one page	2 5 1 00	2 5 1 00	5 0 2 00	5 0 2 00	5 0 2 00	2 5 1 00	5 0 2 00	5 0 2 00
Advertising Rules.	5 0 5 00	5 0 5 00	7 5 22 00	7 5 33 00	100 lbs. 44 00	5 0 5 00	7 5 22 00	100 lbs. 44 00
Bourgeois.	2 5 13 00	2 5 13 00	3 7 26 00	5 0 26 00	5 0 26 00	2 5 13 00	3 7 26 00	5 0 26 00
Minton.	1 1 60	1 1 60	3 20	3 20	3 20	1 1 60	3 20	3 20
Pairs of Cases.								
Total to Print Whole Paper.	\$406 50	\$469 65	\$588 85	\$661 25	\$748 90	\$173 75	\$662 75	\$777 05

*These outfits include the common Washington Hand-Presses. Our Patent Rolling-bed Washington Presses can be had at an advance of twenty-five dollars each. Second-hand Presses at lower rates. These estimates are unusually complete; in comparing with others, notice articles as well as prices. Should you desire to make any changes, please do so, and forward your corrections as for fresh prices. †In case different types are used, change price only; quantity will remain the same.

CINCINNATI TYPE FOUNDRY,
No. 201 Vine Street.

NEWSPAPER ESTIMATES.

Estimate for 6-Column Paper.

Army Press, 14×21 inches, including Roller, Chase, Patent Quoins, Wrenches and Oiler	\$60 00
1 Single Galley	2 00
2 Wood Galleys	60
2 six-inch Composing Sticks	1 50
3 pairs Cases	4 80
6 Job and Triple Cases	5 40
Mallet, Planer, Brush and Bodkins	1 60
10 pounds News Ink	1 60
Column and Head Rules for two pages	5 00
Advertising, Parallel Rules and Dashes	2 60
15 pounds Leads	2 40
80 pounds Long Primer	33 60
50 pounds Brevier	24 00
Head to Paper	2 50
Brevier Title No. 4	3 50
Brevier Italic Title No. 2	3 25
Brevier Antique Extended No. 3	2 50
Long Primer Aldine	2 25
Long Primer Clarendon Extended	3 20
Two-Line Brevier No. 5	2 40
Double English Skeleton Antique No. 2	4 50
Four-Line Brevier Antique Condensed No. 1	2 60
Quads and Spaces, assorted	3 00
Total	\$172 20
Boxing and Shipping	

Estimate for 8-Column Paper.

Army Press, 19×25 inches, including Roller, Chase, Patent Quoins, Wrenches and Oiler	\$120 00
2 Single Galleys	4 00
2 Wood Galleys	60
2 six-inch Composing Sticks	1 50
4 pairs Cases	6 40
1 Double Stand	4 00
10 Job and Triple Cases	9 00
Mallet, Planer, Brush and Bodkins	1 60
10 pounds News Ink	1 60
Column and Head Rules for two pages	9 40
Advertising and Paragraph Rules and Dashes	3 20
2 Steel Composing and 1 Imposing Rule	75
20 pounds Leads and Slugs	3 20
125 pounds Long Primer	52 50
75 pounds Brevier	36 00
Head to Paper	2 50
Brevier Title No. 4	3 50
Brevier Antique Condensed No. 4	2 20
Brevier Antique Extended No. 3	2 50
Long Primer Aldine	2 25
Long Primer Gothic Condensed No. 5	2 75
Long Primer Gothic No. 2	2 95
Pica Doric	3 00
Two-Line Brevier No. 5	2 40
Two-Line Brevier Condensed No. 5	2 00
Paragon Clarendon Extended	4 00
Double English Skeleton Antique No. 2	4 30
Double Pica Octic	3 00
Two-Line English Gothic No. 12	3 00
Double Paragon Skeleton Antique No. 2	5 50
Quads and Spaces, assorted	3 00
Total	\$302 60
Boxing and Shipping	

Estimate for 7-Column Paper.

Army Press, 16 $\frac{3}{4}$ ×22 $\frac{3}{4}$ inches, including Chase, Roller, Patent Quoins, Wrenches and Oiler	\$85 00
1 Single Brass Galley	2 00
2 Wood Galleys	60
2 six-inch Composing Sticks	1 50
3 pairs Cases	4 80
8 Job and Triple Cases	7 20
Mallet, Planer, Brush and Bodkins	1 60
10 pounds News Ink	1 60
Column and Head Rules for two pages	6 00
Advertising, Paragraph and Dash Rules	2 60
2 Steel Composing and 1 Imposing Rule	75
15 pounds Leads, cut to measure	2 40
5 pounds Slugs	80
100 pounds Long Primer	42 00
50 pounds Brevier	24 00
Head to Paper	2 50
Brevier Title No. 4	3 50
Brevier Antique Condensed No. 4	2 20
Brevier Antique Extended No. 3	2 50
Long Primer Aldine	2 25
Long Primer Gothic No. 2	2 95
Long Primer Gothic Condensed No. 5	2 75
Pica Doric	3 00
Two-Line Brevier No. 5	2 40
Two-Line Brevier Condensed No. 5	2 00
Double English Skeleton Antique No. 2	4 30
Four-Line Brevier Antique Condensed No. 1	2 60
Quads and Spaces, assorted	3 00
Total	\$218 80
Boxing and Shipping	

Estimate for 9-Column Paper.

Second-hand Hand Press	\$150 00
Chase and Patent Lock-up	10 00
Roller, complete	6 40
2 Single Galleys	4 00
2 Wood Galleys	60
2 six-inch Composing Sticks	1 50
1 Double Stand	4 00
4 pairs Cases	6 40
10 Job and Triple Cases	9 00
Mallet, Planer, Brush and Bodkins	1 60
10 pounds News Ink	1 60
Column and Head Rules for two pages	11 40
Advertising, Paragraph and Dash Rules	3 75
2 Steel Composing and 1 Imposing Rule	75
25 pounds Leads and Slugs	4 00
150 pounds Long Primer	63 00
100 pounds Brevier	48 00
Head to Paper	2 50
Brevier Title No. 4	3 50
Brevier Antique Condensed No. 4	2 20
Brevier Antique Extended No. 3	2 50
Long Primer Aldine	2 25
Long Primer Gothic Condensed No. 5	2 75
Long Primer Gothic No. 2	2 95
Pica Doric	3 00
Two-Line Brevier No. 5	2 40
Two-Line Brevier Condensed No. 5	2 00
Paragon Clarendon Extended	4 00
Double English Ionic No. 2	5 00
Double Paragon Skeleton Antique No. 2	5 50
Quads and Spaces	3 00
Total	\$369 55
Boxing and Shipping	

Newspaper and Job Office Estimates.

Model Outfit for 7-Column Newspaper and Job Office.

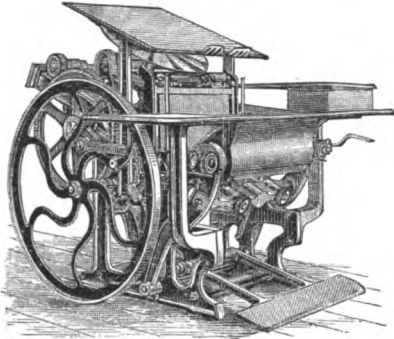

17-24 Combination News or Job Press.....	\$500 00
Casting three Rollers.....	3 75
Side and Foot-Sticks.....	1 65
3 Brass Galleys.....	6 00
2 six-inch Composing Sticks.....	1 50
1 twelve-inch and one Wood Job Stick.....	3 80
4 pairs Cases.....	6 40
30 Job and Triple Cases.....	27 00
2 Double Stands, with Racks.....	8 00
Mallet, Planer, Shooting Sticks, Quoins.....	2 00
Lye Brush and Bodkins.....	1 00
25 pounds News Ink.....	3 00
Column and Head Rules for two pages.....	8 00
50 Advertisement Rules.....	2 00
12 Paragraph Rules.....	72
50 Single Dash Rules.....	3 50
30 pounds Leads and Slugs.....	4 80
2 Composing Rules.....	50
150 pounds Long Primer.....	63 00
50 pounds Brevier.....	24 00
25 pounds Double Pica Poster.....	9 50
Head to Paper.....	2 50
1 font Brevier Gothic Condensed No. 5.....	2 75
1 " Pica Doric.....	3 00
1 " Paragon Doric.....	4 50
1 " Two-Line English Aldine.....	6 40
1 " Two-Line Nonpareil No. 5.....	1 50
1 " Two-Line Nonpareil Condensed No. 5.....	2 20
1 " Brevier Gothic Italic No. 2.....	2 60
1 " Double Pica Norman Condensed.....	4 25
1 " Three-Line Nonpareil Celtic No. 2.....	3 00
1 " Nonpareil French Clarendon.....	2 00
1 " Pica Modern Antique Wide.....	3 65
1 " Three-Line Pica Modern Antique Wide.....	7 00
1 " Six-Line Pica Modern Antique Condensed.....	10 75
1 " Five-Line Pica Gothic Extra Condensed.....	5 00
1 " Three-Line Pica Latin Antique.....	7 85
1 " Paragon Latin Antique.....	4 70
1 " Nonpareil Antique Condensed No. 2.....	2 15
1 " Long Primer Antique Condensed No. 2.....	2 95
1 " Four-Line Pica Skeleton Antique No. 2.....	5 75
1 " Two-Line Brevier Antique Extended No. 3.....	2 25
1 " Nonpareil Antique Extended No. 3.....	2 40
Scripts and Fancy Type.....	30 00
10 pounds Long Primer Law Italic.....	7 40
Labor-Saving Rule, 6-to-pica No. 71.....	2 00
Labor-Saving Double Rule.....	3 60
10 pounds long Leads.....	1 50
Reglet and Furniture.....	2 00
Wood Rule, assorted.....	1 20
3 fonts Wood Type.....	25 00
Job Inks, assorted.....	5 00
Quads and Spaces, assorted.....	4 00
Total.....	\$850 97
Boxing and Drayage.....	

Outfit for 5-Column Folio Newspaper and Job Office.

Half Medium Job Press—Second-Hand.....	\$225 00
Casting Rollers.....	3 00
Side and Foot-Sticks.....	1 25
3 Brass Galleys.....	6 00
2 six-inch Composing Sticks.....	1 50
1 twelve-inch and one Wood Job Stick.....	3 80
4 pairs Cases.....	6 40
30 Job and Triple Cases.....	27 00
2 Double Stands, with Racks.....	8 00
Mallet, Planer, Shooting Sticks, Quoins.....	2 00
Lye Brush and Bodkins.....	1 00
10 pounds News Ink.....	1 60
Job Inks, assorted.....	5 00
Column and Head Rules for two pages.....	5 00
40 Advertising Rules.....	1 60
10 Paragraph Rules.....	60
40 Single Dash Rules.....	2 80
30 Double Dash Rules.....	2 40
20 pounds Leads and Slugs.....	3 20
2 Composing Rules.....	50
75 pounds Long Primer.....	31 50
50 pounds Brevier.....	24 00
25 pounds Great Primer No. 5.....	9 50
25 pounds Double Pica.....	9 50
Head to Paper.....	2 50
1 font Nonpareil Gothic No. 9.....	3 30
1 " Long Primer Gothic No. 9.....	3 00
1 " Brevier Gothic Condensed No. 5.....	2 75
1 " Pica Gothic Condensed No. 5.....	2 75
1 " Paragon Gothic Condensed No. 5.....	4 15
1 " Long Primer Latin Antique.....	2 95
1 " Paragon Latin Antique.....	4 70
1 " Three-Line Pica Latin Antique.....	7 85
1 " Brevier Ionic No. 2.....	2 90
1 " Three-Line Nonpareil Ionic No. 2.....	3 65
1 " Four-Line Brevier Ionic No. 2.....	5 95
1 " Double English Skeleton Antique No. 2.....	4 30
1 " Four-Line Pica Skeleton Antique No. 2.....	5 75
1 " Double English Modern Antique Wide.....	5 60
1 " Four-Line Pica Modern Antique Wide.....	8 90
1 " Pica Modern Antique Condensed.....	2 75
1 " Three-Line Pica Modern Antique Cond.....	5 00
1 " Six-Line Pica Modern Antique Condensed.....	10 75
1 " Nonpareil Antique Extended No. 3.....	2 40
1 " Long Primer Antique Extended No. 3.....	2 60
1 " Two-Line Pica Antique Extended No. 3.....	3 00
1 " Three-Line Nonpareil Norman Condensed.....	3 40
1 " Double Pica Norman Condensed.....	4 25
1 " Nonpareil Celtic No. 2.....	1 40
1 " Brevier Celtic No. 2.....	2 10
1 " Two-Line Pica Celtic No. 2.....	4 00
1 " Three-Line Nonpareil Pen Text.....	5 00
1 " Double English Pen Text.....	8 40
1 " Two-Line Brevier No. 5.....	2 40
1 " Two-Line Brevier Condensed No. 5.....	2 00
1 " Three-Line Nonpareil French Ionic.....	3 25
1 " Double English French Ionic.....	6 30
10 pounds Long Primer Law Italic.....	7 40
1 font Six-Line Pica Parisian (3 A and figures).....	5 05
1 " Ten-Line Ætna, (3 A and figures).....	10 10
1 " Fifteen-Line French Clar. (3 A and figures).....	8 25
1 " Labor-Saving Rule, 6-to-pica No. 71.....	2 00
1 " Labor-Saving Rule, 6-to-pica No. 1.....	2 00
1 " Labor-Saving Double Rule.....	3 60
10 pounds long Leads.....	1 50
Reglet and Furniture.....	2 00
Wood Rule, assorted.....	60
Quads and Spaces, assorted.....	6 00
Total.....	\$570 65
Boxing and Drayage.....	

JOB OFFICE ESTIMATES.

Job Office for General Job and Poster Work.

Half Folio Press, 12x17, Receding Bed	\$325 00
Rollers cast, or Composition—10 pounds	3 00
1 Double Stand	4 00
Combination Cabinet No. 2	65 00
5 pairs Cases	8 00
4 Job Cases	3 60
1 Rule Case	1 15
1 Job Galley, 6x10	2 00
1 " " 12x18	3 50
3 Wood Galleys	90
1 each, 6, 10, and 16-inch Composing Sticks	5 00
1 3/8-inch Wood Job Stick	1 50
Imposing Stone and Stand, 30x60 inches	19 00
Quoins, Reglet and Furniture	3 25
Mallet, Planer, Shooting Stick	1 00
Lye Brush, Nippers	1 50
2 dozen assorted Feed Guides	1 20
Miter Box and Saw	2 00
Lead Cutter	4 00
25-inch Paragon Cutter	110 00
50 pounds Metal Furniture	12 50
25 pounds assorted Labor-Saving Slugs	6 25
30 " " " " Leads	7 50
Curves and Clamps	8 00
1 font Flourishes	3 50
Assorted Job Inks	5 00
Ink Slab and Knife	3 00
Pearl, card font	5 00
25 pounds Nonpareil Old Style	14 50
25 pounds Brevier Old Style	12 00
50 pounds Long Primer No. 11	21 00
25 pounds Three-Line Nonpareil Roman	9 50
25 pounds Double Pica Roman	9 50
5 fonts Wood Type, assorted	50 00
Double Pica Pen Text No. 2	5 40
Five-Line Pica Heading Script, No. 1 lower case	17 50
10 pounds Long Primer Copper-Plate Italic	7 40
4 pounds Long Primer Brass Leaders	6 00
10 feet Labor-Saving Rule, 6-to-pica No. 1	2 00
10 " " " 4-to-pica No. 2	2 40
10 " " " Pearl No. 3	3 60
10 " " " Nonpareil No. 4	4 80
10 " " " Nonpareil No. 7	4 80
8 sets Brass Corner Quads	1 20
Ornamental Corners	3 00
Combination Border, Series 48	6 00
" " " 46	5 10
3 fonts small Borders	7 45
3 sizes of Celtic No. 2	10 50
2 " " Light Celtic	8 50
3 " " Latin Antique	19 10
3 " " Modern Antique Condensed	13 20
4 " " Gothic No. 9	24 30
3 " " Modern Antique	16 40
1 font Brevier Antique Condensed No. 2	2 70
1 " Pica Antique Condensed No. 2	3 00
1 " Double English Skeleton Antique No. 2	4 30
1 " Four-Line Pica Skeleton Antique No. 2	5 75
1 " Two-Line Brevier Antique Extended No. 3	2 25
1 " Two-Line Pica Antique Extended No. 3	3 00
1 " Pearl French Clarendon Extended	2 65
1 " Long Primer French Clarendon Extended	3 45
1 " Nonpareil Gothic Italic No. 3	2 40
1 " Pica Gothic Italic No. 1	3 00
1 " Nonpareil Ionic	3 00
1 " Nonpareil Light-Face Extended	3 15
6 " Latest style Black and Ornamented	30 00
Job Quads and Spaces	10 00
Check Blanks, Dashes, Ornaments	5 00
Total	\$984 15
Boxing and Drayage	

Small Job Office.

9x12 Nonpareil Press, with Receding Bed	\$225 00
1 set Rollers, cast	1 50
1 Stand, with Racks	4 00
4 pairs Cases	6 40
1 20-Case Cabinet	18 00
1 Brass Job Galley, 8 1/4x13	2 50
2 Wood Galleys	60
2 Composing Sticks	3 00
Reglet and Furniture	2 00
Miter Box and Saw	2 50
1 Lead Cutter	4 00
25 pounds Metal Furniture	6 25
20 pounds Labor-Saving Leads	5 00
10 pounds Job Leads, assorted	1 50
Mallet, Planer, Shooting Stick	1 40
Quoins, Brush, Nippers	1 60
Labor-Saving Rule, Single	2 00
" " " Double	3 60
" " " Parallel	3 60
" " " Dotted	2 00
4 fonts Borders	10 00
Metal and Brass Flourishes	8 50
Curves and Clamps	8 00
25 pounds Nonpareil	14 50
25 pounds Brevier	12 00
25 pounds Long Primer	10 50
25 pounds Pica	9 50
1 font Three-Line Nonpareil No. 5	2 20
1 " Paragon Title No. 4	4 30
3 sizes of Old Style Condensed No. 2	10 20
2 " " Title Extended No. 3	6 60
3 " " Gothic No. 10	11 50
3 " " Latin Antique	16 95
3 " " Celtic No. 2	10 50
3 " " Black Condensed No. 3	3 75
2 " " Black Ornamented No. 3	3 75
Double Pica Payson Script, card font	3 50
10 pounds Long Primer Copper-Plate Italic	7 40
3 fonts latest style Fancy Letter	18 00
Job Quads and Spaces, assorted	5 00
Cuts, Dashes and Ornaments	5 00
Job Inks, assorted	5 00
Total	\$483 10
Boxing and Drayage	

Job Outfit for Village Newspaper Office, work to be done on Hand-Press.

50 pounds Double Pica Roman	\$19 00
3 fonts Wood Letter	20 00
50 yards Reglet and Furniture	2 00
1 Wood Job Stick	2 00
4 yards Wood Rule	50
Three-Line Pica Antique No. 6	6 70
Double Paragon Antique Condensed No. 2	7 00
Four-Line Pica Skeleton Antique No. 2	5 75
Four-Line Pica Modern Antique Condensed	6 25
Double English Modern Antique	6 40
2 sizes Antique Condensed No. 4	9 40
3 sizes Oetic	9 40
Double English Black Ornamented No. 3	2 10
Two-Line Pica Ornamented No. 30	2 50
Quads and Spaces	3 00
15 pounds Leads, assorted	2 25
Ink—Black, Red, Blue	2 50
1 Double Stand	4 00
1 pair Cases	1 60
5 Job and Triple Cases	4 50
Total	\$116 85
Boxing and Drayage	

JOB OFFICE ESTIMATES.

Outfit for Small Job Office.

8×12 Reliable Press	\$180 00
1 Double Stand	4 00
1 16-Case Cabinet	15 00
2 pairs Cases	3 20
4 Job and Triple Cases	3 60
2 Wood Gallies	60
1 Brass Job Galley, 6×10	2 00
2 Composing Sticks	3 00
Reglet and Furniture	2 00
1 Lead Cutter	2 50
10 pounds Job Leads, assorted	1 50
Mallet and Planer	80
Shooting Stick and Quoins	1 20
Lye Brush and Nippers	1 00
1 dozen Feed Guides	60
Labor-Saving Single Rule	2 00
" " Double Rule	3 60
Nonpareil Border No. 219	2 60
Half Nonpareil Border No. 27	2 25
Metal Flourishes, Series A	3 50
25 pounds Brevier	12 00
25 pounds Pica	9 50
1 font Three-Line Nonpareil No. 5	2 20
1 " Paragon Title No. 2	4 30
1 " Brevier Italic Title No. 2	3 25
1 " Three-Line Nonpareil Italic Title No. 2	2 50
1 " Long Primer Title Extended No. 3	3 25
1 " Paragon Latin Antique	4 70
1 " Pica Modern Antique	3 00
1 " Double English Gothic No. 9	6 50
1 " Pica Celtic No. 2	2 20
1 " Two-Line Pica Celtic No. 2	4 00
1 " Three-Line Nonpareil French Antique	2 75
1 " Double English French Ionic	6 30
1 " Paragon Wide Black	4 25
1 " Double English Black Ornamented No. 3	2 10
1 " Pearl French Clarendon Extended	2 65
1 " Two-Line Brevier Antique Extended No. 3	2 25
1 " Brevier Gothic No. 11	1 75
1 " Three-Line Nonpareil Gothic No. 9	4 00
1 " Two-Line Pica Concave	3 50
3 fonts latest style Fancy Letter	15 00
2 Electro Date Lines	1 00
Check Blanks and Ornaments	2 00
Dashes	1 00
Job Inks, assorted	3 00
Quads and Spaces, assorted	2 00
Total	\$345 90

Boxing and Drayage

Outfit for Small Job Office.

5½×7 Self-Inking Press	\$25 00
6 Yankee Job Cases	4 50
1 eight-inch Composing Stick	80
1 pound each, Black, Blue, and Red Ink	2 00
Reglet, Furniture, and Quoins	50
2 pounds Leads	30
Mallet, Planer, Shooting Stick, and Tweezers	1 80
1 Wood Galley	30
2 feet Single Rule, 2 feet Dotted Rule	30
2 feet Double Rule, 2 feet Wave Rule	50
Electro Date Line	40
Long Primer Roman Card Font	3 70
Nonpareil Antique Extended No. 3	2 40
Three-Line Nonpareil Celtic No. 2	3 00
Double Pica Norman Condensed	4 25
Double Pica Payson Script	3 50
Paragon Octic	2 30
Four-Line Brevier Antique Condensed No. 1	3 60
Quads and Spaces, assorted	2 50
Total	\$61 65

Boxing and Drayage

Small Job Office, in Connection with Weekly Newspaper.

Second-Hand Job Press, from	\$1 00 to \$200 00
1 Double Stand, with Racks	4 00
1 pair Cases	1 60
10 Job and Triple Cases	9 00
1 twenty-four-inch Job Stick, wood	1 10
1 twelve-inch Job Stick, steel	1 80
1 Job Galley, 8¼×13	2 50
1 Lead Cutter	4 00
10 pounds long Leads	1 50
1 font Labor-Saving Rule, 6-to-pica No. 71	2 00
1 " " " " 4-to-pica No. 2	2 40
1 " " " " 6-to-pica No. 1	2 00
1 " " " " Pearl No. 7	3 60
1 Labor-Saving Rule Case	1 15
50 yards Reglet and Furniture	2 00
Job Inks, assorted	5 00
50 pounds Double Pica Roman	19 00
3 fonts Wood Type	20 00
Brevier Italic Title No. 2	3 25
Three-Line Nonpareil Pen Text	5 00
Long Primer Title Extended No. 3	3 25
Pica Gothic Condensed No. 5	2 75
Three-Line Nonpareil Latin Antique	3 75
Two-Line English Skeleton Antique No. 2	4 30
Four-Line Pica French Clarendon	9 00
Pica Modern Antique	3 00
2 fonts Egyptian Extra Condensed	8 65
Paragon Gothic No. 9	5 25
Nonpareil Antique Condensed No. 2	2 15
Paragon Wide Black	4 25
Double English Black Ornamented No. 3	2 10
2 fonts latest style Fancy Letter	12 00
Check Blanks, Dashes and Ornaments	3 00
10 yards Wood Rule	1 20
2 fonts Borders	4 85
Metal Flourishes, Series A	3 50
1 font Curves and Clamps	8 00
Quads and Spaces, assorted	3 00

Total **\$374 90**
Boxing and Drayage

Outfit for Small Job Office.

Self-Inking Lever Press	\$50 00
1 twelve-case Cabinet	12 00
1 ten-inch Composing Stick	90
1 pound each, Black, Blue, and Red Ink	2 00
Reglet, Furniture, and Quoins	1 00
5 pounds Leads	75
Mallet, Planer, Shooting Stick, Tweezers	1 80
1 Wood Galley	30
2 fonts Borders	4 85
Labor-Saving Single Rule, 6-to-pica	2 00
2 feet Double Rule, 2 feet Wave Rule	50
2 feet Dotted Rule	16
Business Cuts, assorted	2 00
1 Electro Date Line	40
Nonpareil Aldine	2 00
Nonpareil Antique Extended No. 3	2 40
Brevier Antique Condensed No. 4	2 20
Long Primer Antique Condensed No. 2	2 95
Pica Modern Antique	3 00
Three-Line Nonpareil Skeleton Antique No. 2	2 75
Pica Norman Condensed	3 20
Three-Line Nonpareil Gothic Condensed No. 5	3 60
Three-Line Pica Modern Antique Condensed	5 00
Long Primer Celtic No. 2	2 20
Double English Black Ornamented No. 3	2 10
Three-Line Nonpareil Pen Text	5 00
Two-Line Pica Ornamented No. 26	2 50
Two-Line Nonpareil Ornamented No. 26	1 50
Quads and Spaces, assorted	4 00

Total **\$123 06**
Boxing and Drayage

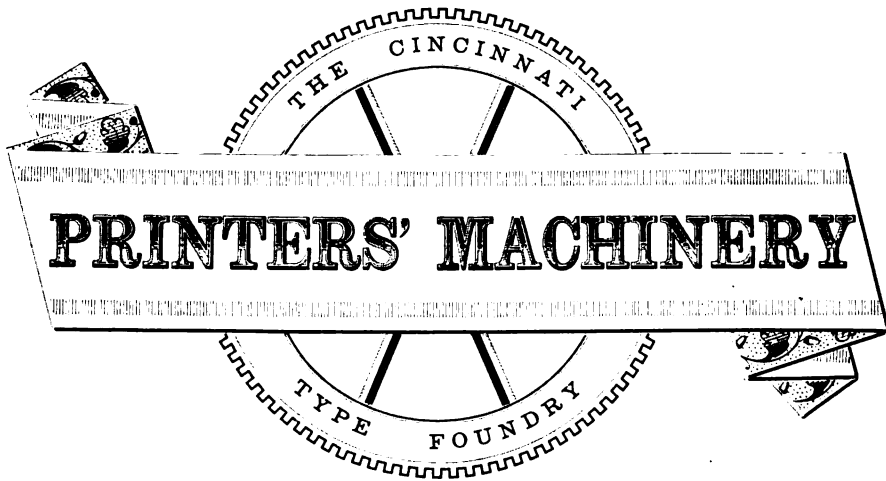

The Machinery shown here is only a portion
of what we make. A full Catalogue of Printing
Machinery will be mailed on application.

THE CINCINNATI TYPE FOUNDRY.

THE ARMY PRESS.

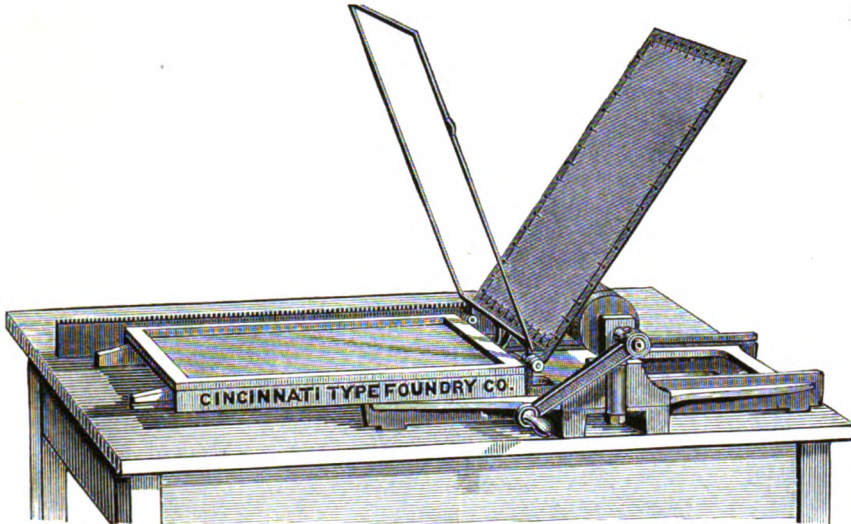

SIZES:

- 14 $\frac{3}{8}$ x21 inches inside chase, prints 6-column folio page.
- 16 $\frac{5}{8}$ x22 $\frac{3}{4}$ inches inside chase, prints 7-column folio page.
- 19x25 inches inside chase, prints 8-column folio page.
- 19 $\frac{1}{2}$ x26 inches inside chase, prints two 5-column quarto pages.

WASHINGTON HAND PRESS.

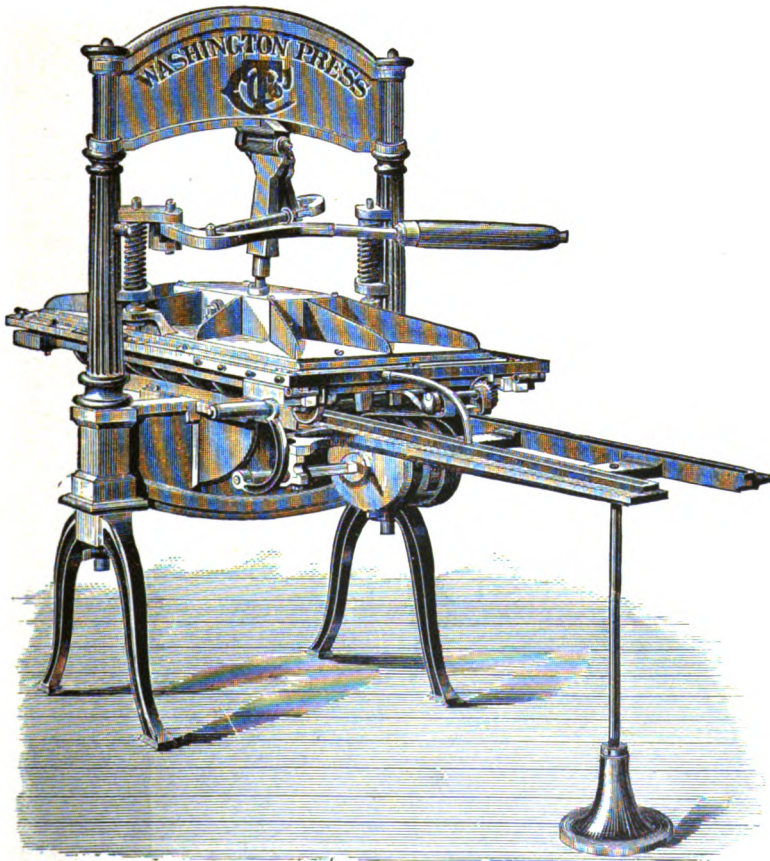

CINCINNATI
→ COUNTRY CYLINDER. ←

TABLE DISTRIBUTION.

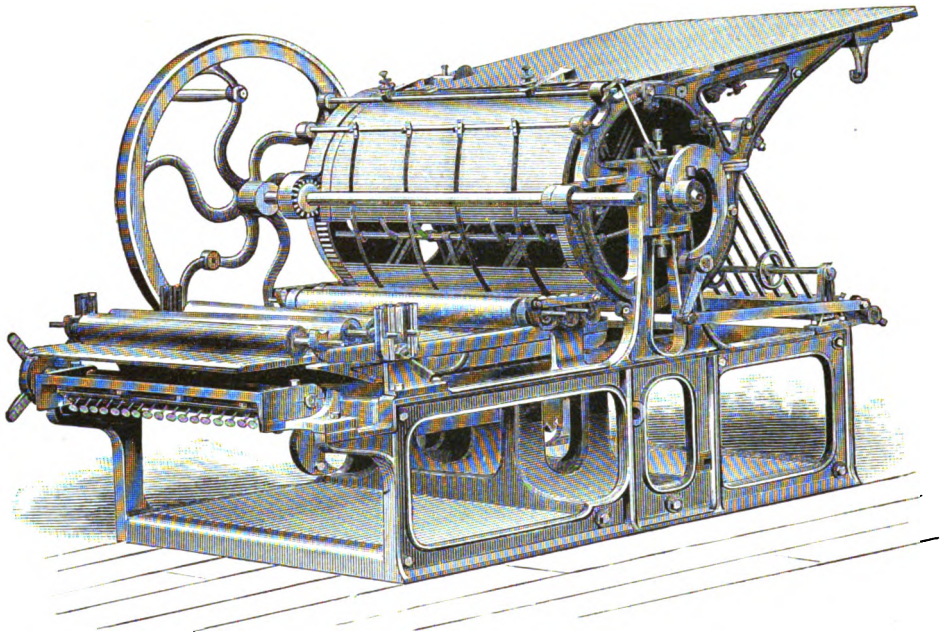

NONPAREIL
NEWSPAPER AND JOB PRESS.

PRINTS 1 PAGE OF A 7-COLUMN PAPER.

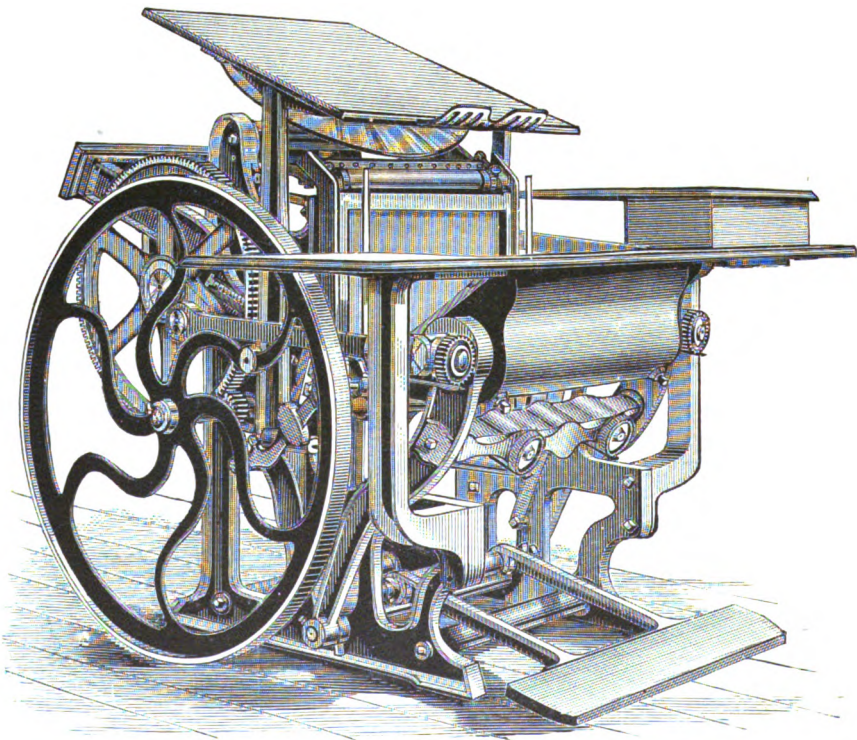

For Sizes and Prices, see Price List.

xxii

Cincinnati Type Foundry, 201 Vine St.

FIRST-CLASS DRUM CYLINDER PRESSES.

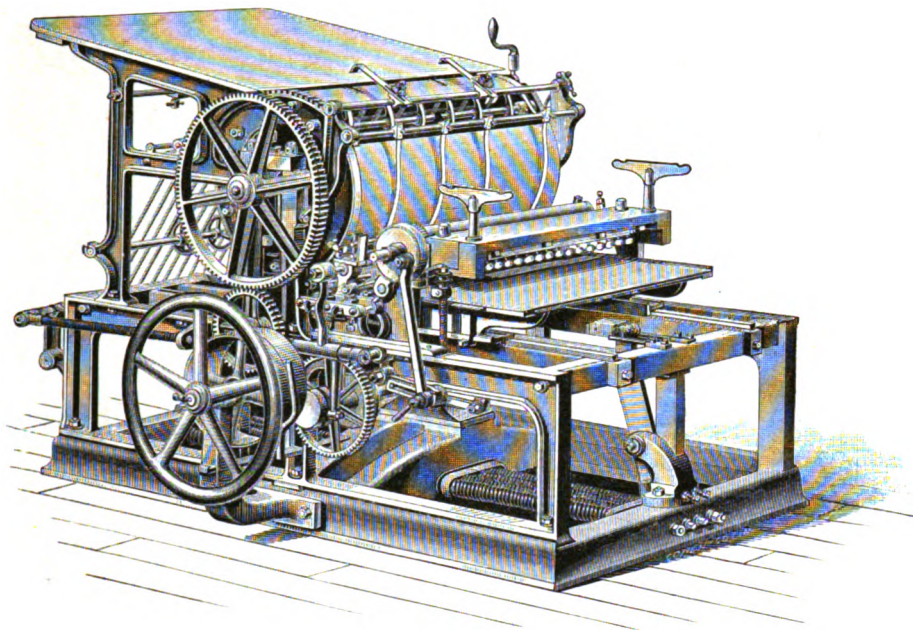

HALF-MEDIUM CYLINDER PRESS.

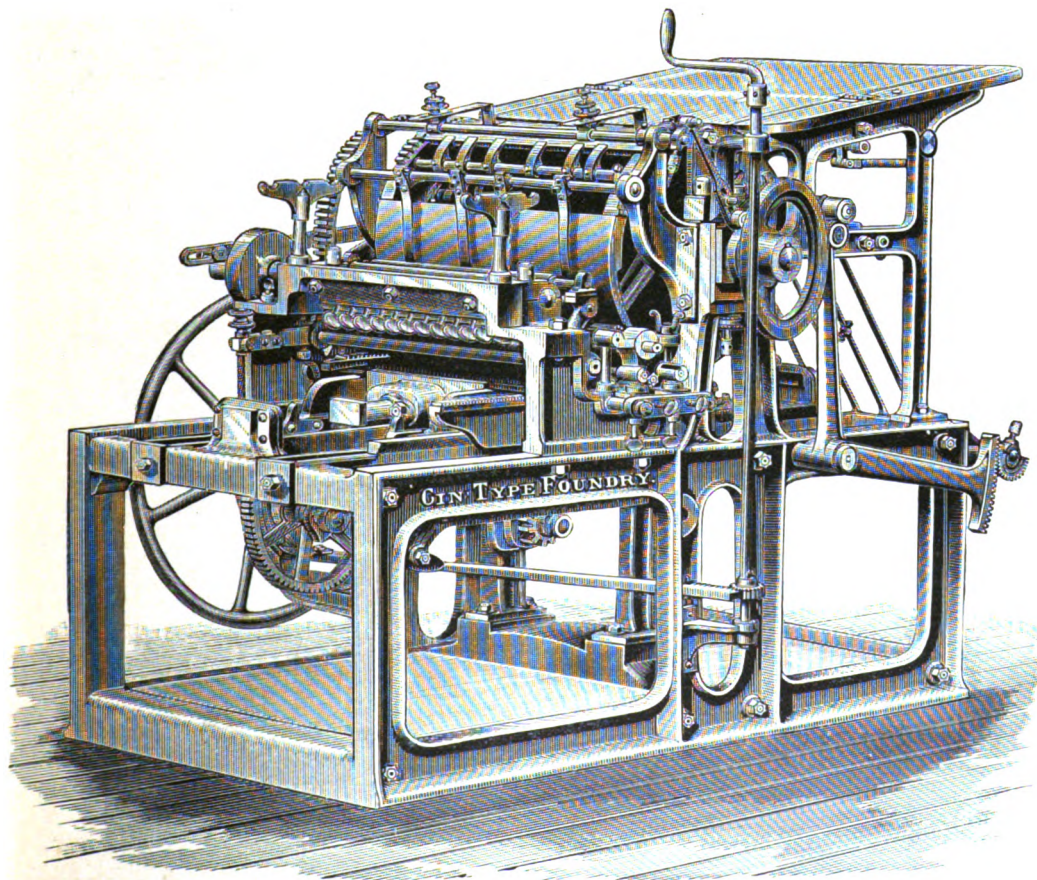

For Sizes and Prices, see Price List.

xxiii

Cincinnati Type Foundry, 201 Vine St.

RELIABLE JOB PRESS.

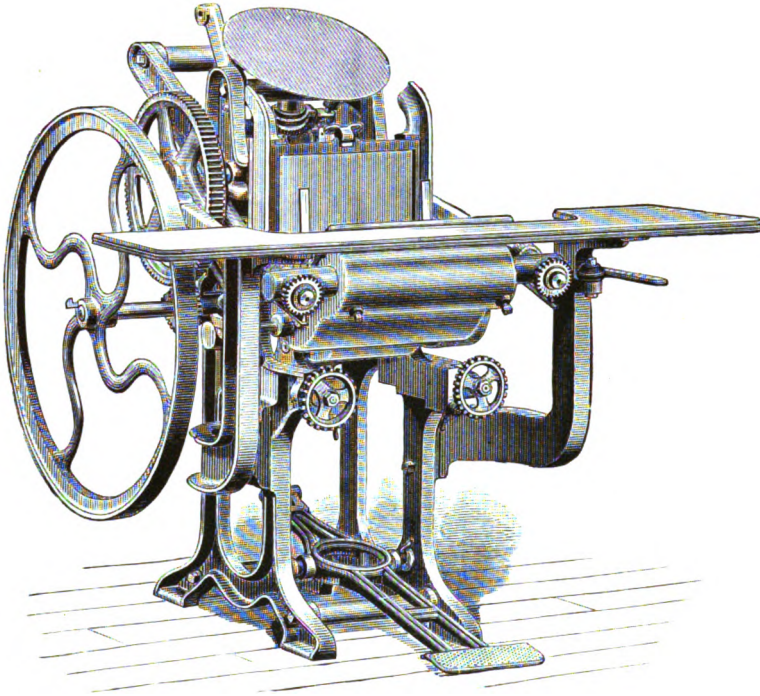

SIZES:

$8\frac{3}{4} \times 12\frac{3}{4}$ and 11×15 inches, inside chase.

NONPAREIL JOB PRESS, WITH RECEDING BED.

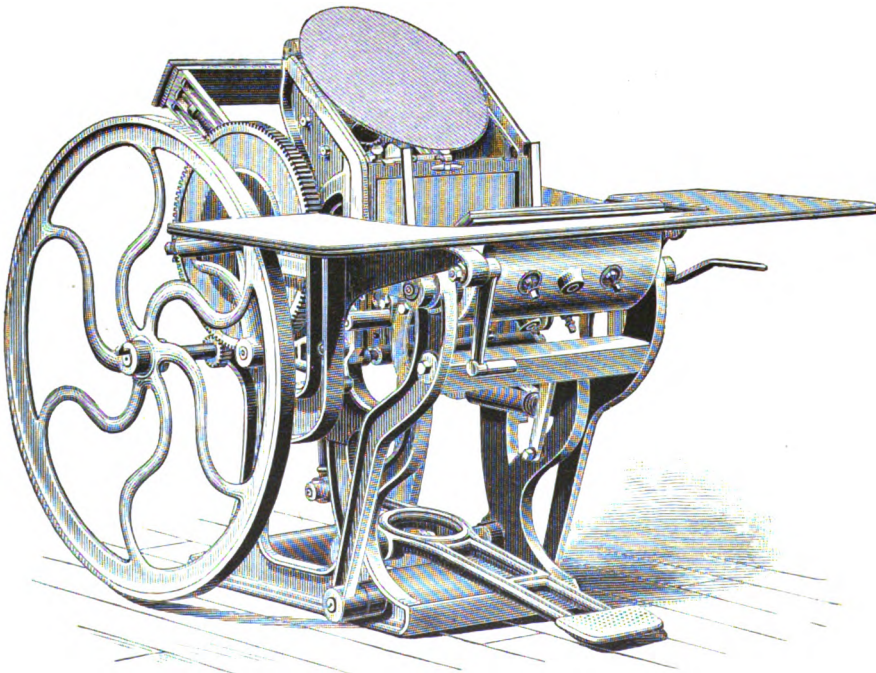

SIZES:

9×12 , $10\frac{3}{4} \times 15\frac{3}{4}$ and 12×17 inches, inside chase.

For Prices, see Price List.

xxiv

Cincinnati Type Foundry, 201 Vine St.

One Pair Quarto Chases.

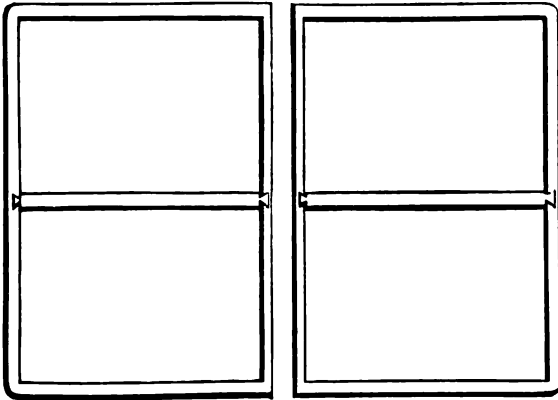

Skeleton Chase.

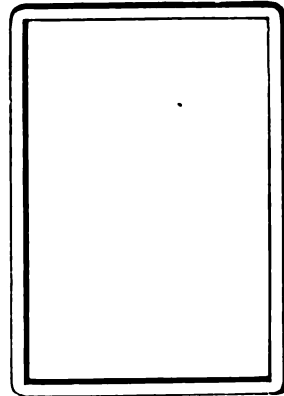

One Pair News Chases.

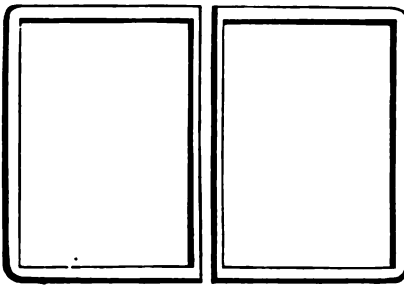

Book Chase, with Shifting Bars.

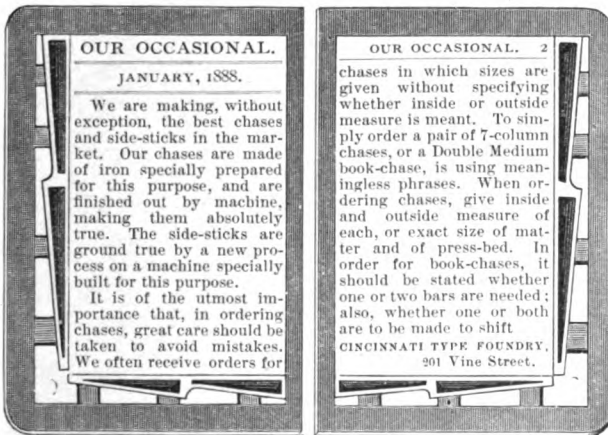
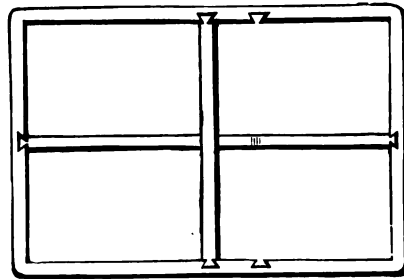

Heading Chase.

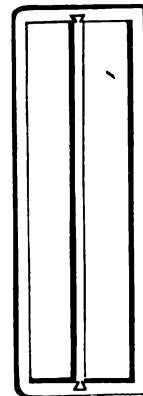

Hempel's Patent Quoin.

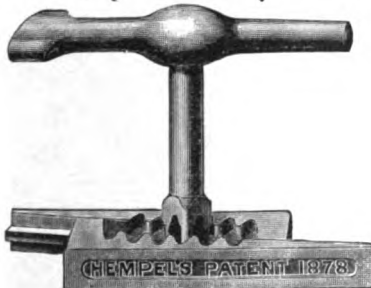

For Prices, see Price List.

Iron Side and Foot Sticks.

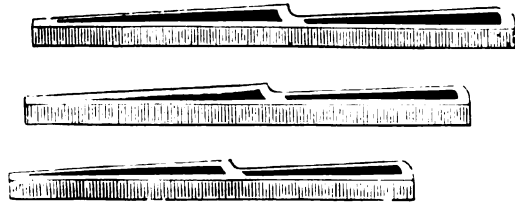

XXV

Cincinnati Type Foundry, 201 Vine St.

ELM CITY CARD CUTTER.

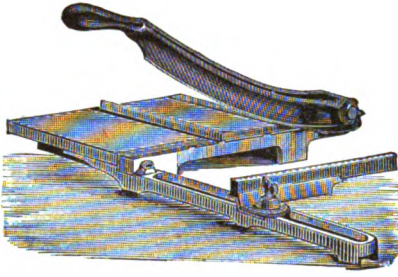

PREMIUM CARD CUTTER No. 1.

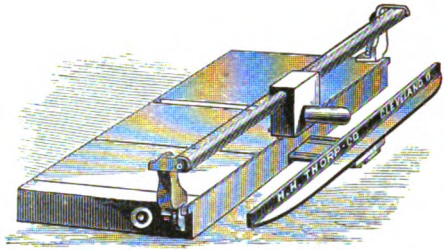

BARTH'S PATENT LEAD CUTTER.
With Reversible Knives.

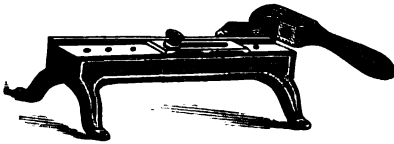

PREMIUM CARD CUTTER No. 2.

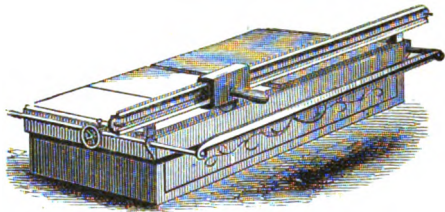

LITTLE GIANT LEAD AND RULE CUTTER.

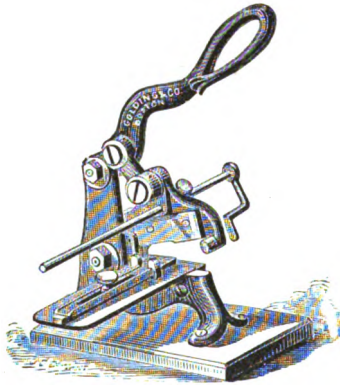

READY ROLLER PROOF PRESS.}

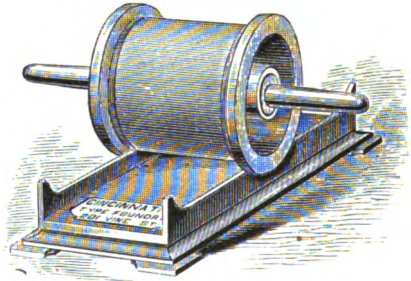

ROUND HOLE PERFORATOR.

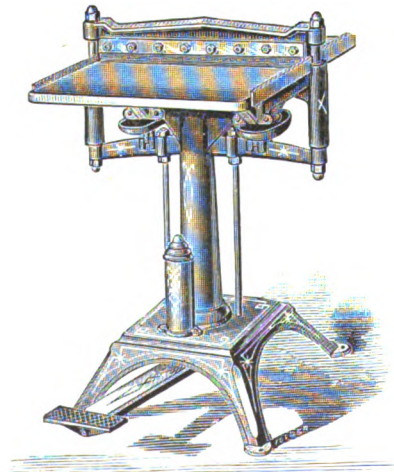

UNIVERSAL RULE SHAPER.

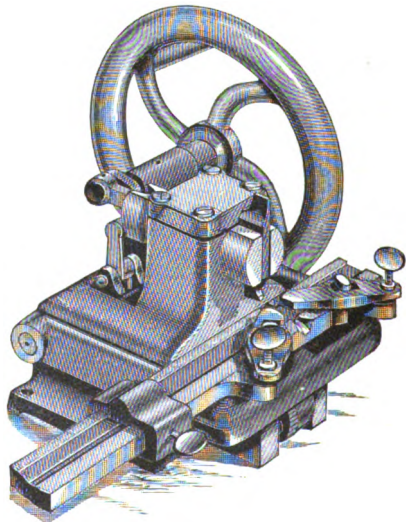

For Prices, see Price List.

xxvi

Cincinnati Type Foundry, 201 Vine St.

PAPER CUTTERS.

PLOW PAPER CUTTER.

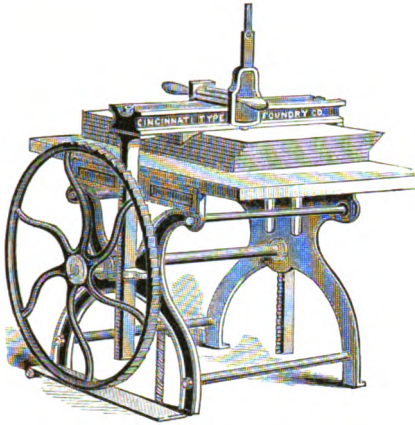

Cuts 28 inches.

CLIPPER PAPER CUTTER.

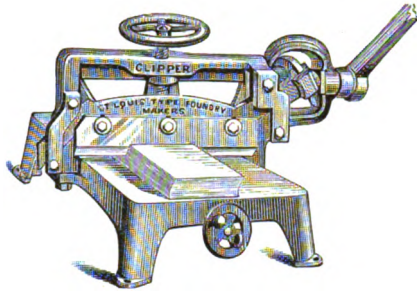

Cuts 12 inches.

THE BOSS PAPER CUTTER.

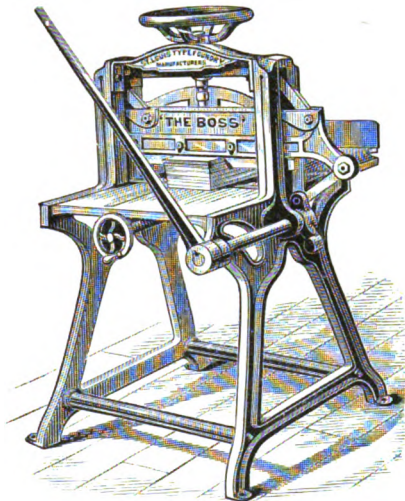

Cuts 23 inches.

LEADER PAPER CUTTER.

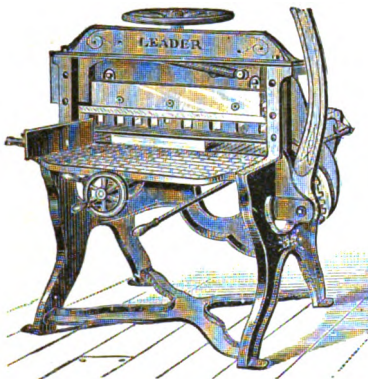

Cuts 23, 28, 30 and 32 inches.

PARAGON PAPER CUTTER.

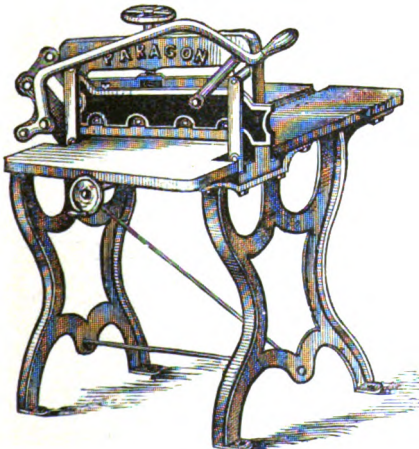

Cuts 22½ and 25 inches.

SANBORN'S '87 PAPER CUTTER.

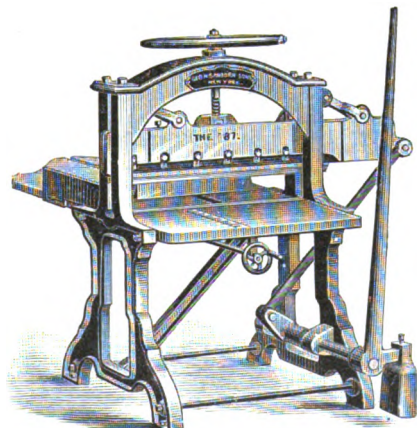

Cuts 25 and 32 inches.

For Prices, see Price List

xxvii

Cincinnati Type Foundry, 201 Vine St.

Albion Composing Stick.

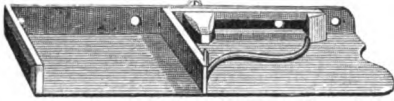

Grover Composing Stick.

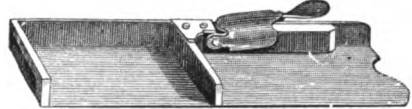

Screw Composing Stick.

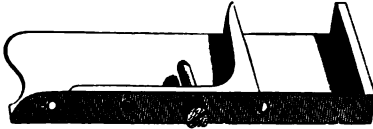

Steel Composing Rule. Steel Make-up Rule.

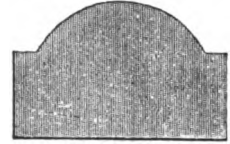

Wire Gauge Pins.

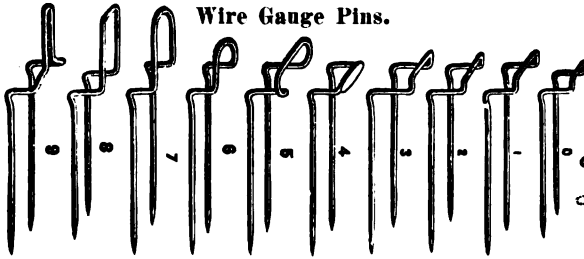

Patent Gauge Pins.



Spring Tongue Gauge Pins.



Spring Bodkin.

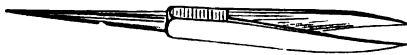

Pocket Bodkin.



Hart's Counter.



Radiating Sheet Supporters.

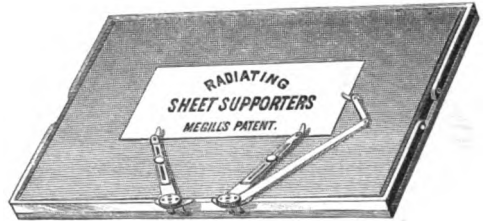

Iron Miter Box.

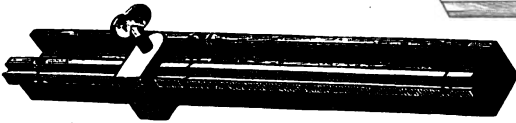

Cott's Padding Box.

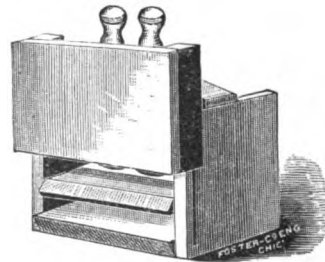

Wooden Miter Box.

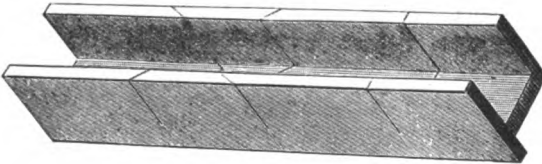

**Golding's Padding Box.
(CLOSED.)**

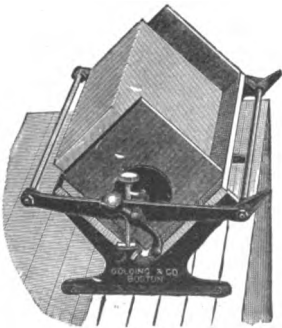

**Golding's Padding Box.
(APPLYING GLUE.)**

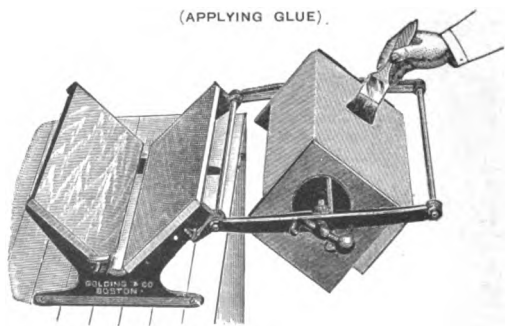

For Prices, see Price List.

xxviii

Cincinnati Type Foundry, 201 Vine St.

MAILING MATERIAL.

LONGLEY'S TIMES MAILER.

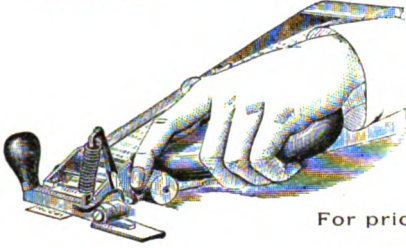

PINER'S MUSTANG MAILER.

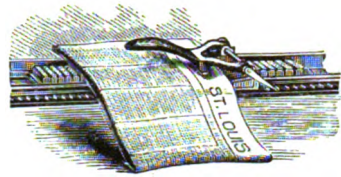

For prices, see Price List.

Long Primer Mailing Type at 4¢ cents per pound.

Frank Talbott	31 $\frac{1}{2}$ 78	J F Murphy	23 $\frac{1}{2}$ 78	Martin Kramer	14 $\frac{1}{2}$ 79
C W Smith	3 $\frac{1}{2}$ 77	S M Pendleton	29 $\frac{1}{2}$ 78	G L Waterman	4 $\frac{1}{2}$ 79
E Harding	18 $\frac{1}{2}$ 79	Mary Stivers	19 $\frac{1}{2}$ 79	Ferd Holmes	29 $\frac{1}{2}$ 79
DANBURY	Mass	COLD SPRINGS	Tex	ROCHESTER	Mich

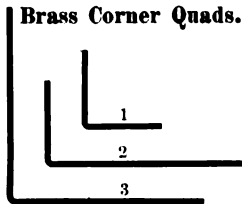

Brass Corner Quads.

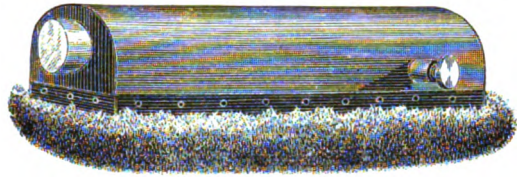

Bronzing Pad.



Lamp Holder.

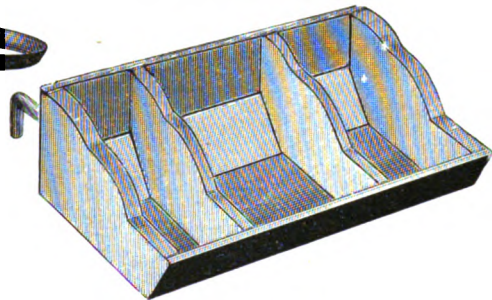

Portable Sort Case.

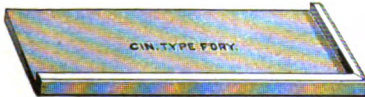

Wooden Galley.

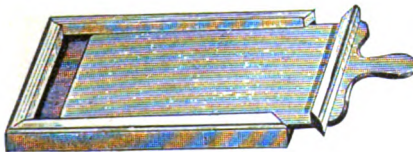

Slice Galley.



Steel Shooting Stick.



Brass Shooting Stick.



Brass-Lined Galley.



Mallet.



Planer.

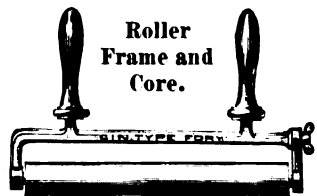

Roller Frame and Core.

For Prices, see Price List.

xxix

Cincinnati Type Foundry, 201 Vine St.

CABINETS.

COMBINATION CABINET, No. 2.

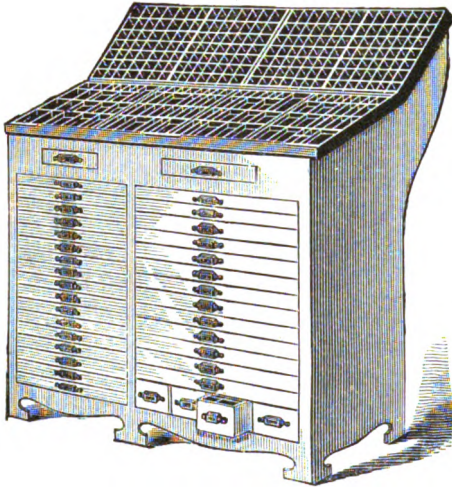

Contains thirteen full Job Cases, seventeen two-thirds Job Cases, four Sort Drawers, and has two pair News Cases on top.

These Cabinets are made of black walnut.

COMBINATION CABINET, No. 1.

Contains eighteen full Job Cases, eighteen two-thirds cases, ten Drawers for Sorts, such as extra figures, leaders, quads, etc.; has two pairs of cases on top and a Galley Rest.

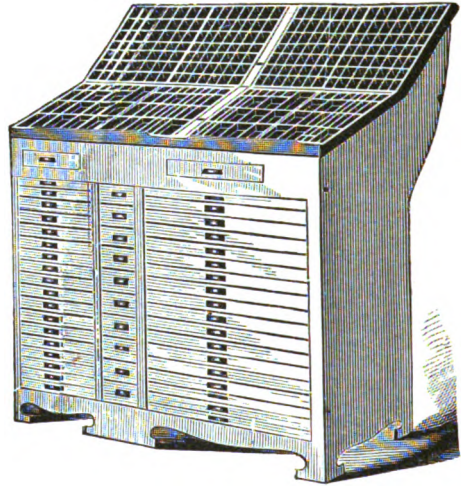

BRACKET CABINET.

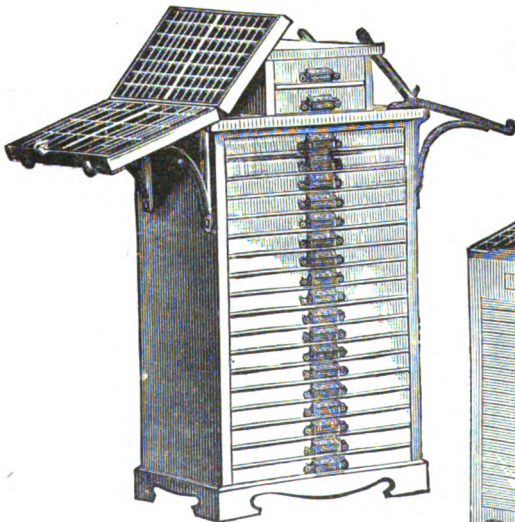

With two-thirds, three-fourths, or full-size cases. Contains eighteen cases, and has four cases and two drawers on top.

The iron brackets shown on above Cabinet will be found of great convenience, as they can be used in different places—on tables, etc.—to great advantage.

EAGLE CABINET.

This Cabinet contains sixteen full Job Cases, eighteen two-thirds Job Cases, two Copy Drawers, and has two pairs News Cases on top.

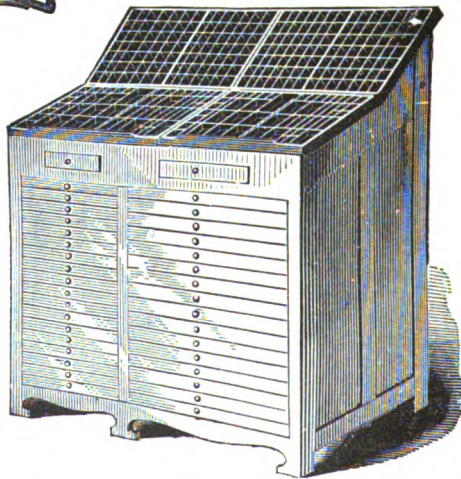

CALIFORNIA CABINET.

Contains fourteen two-thirds Cases, six full Job Cases, four Triple Cases, two pairs cases, two pairs on top, two Copy Drawers.

For Prices, see Price List.

xxx

Cincinnati Type Foundry, 201 Vine St.

CABINETS, Etc.

**Eureka
Labor-Saving Lead and
Slug Rack.**

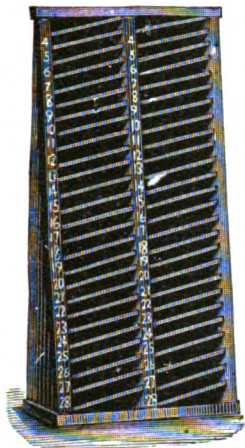

Galley Rack.

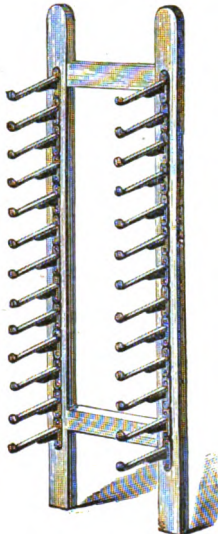

Two-third Galley-top Cabinet.

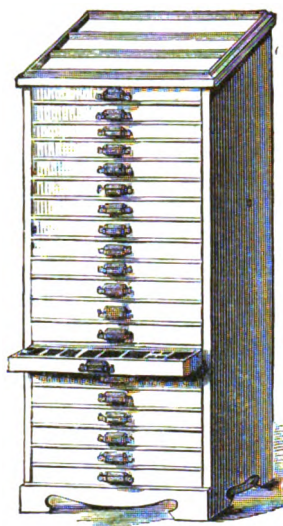

Imposing Stone.

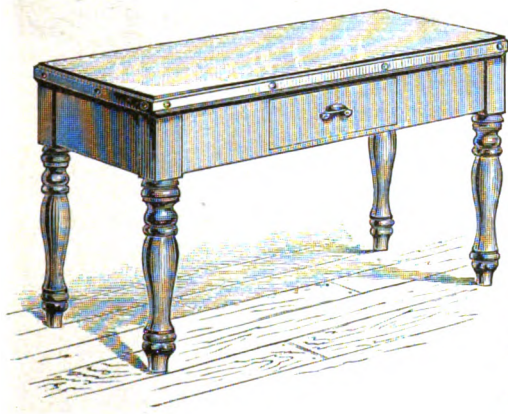

Labor-Saving Furniture and Cabinet.

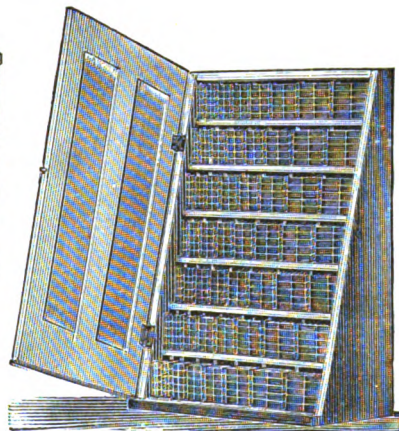

Double Stand, with Rack.

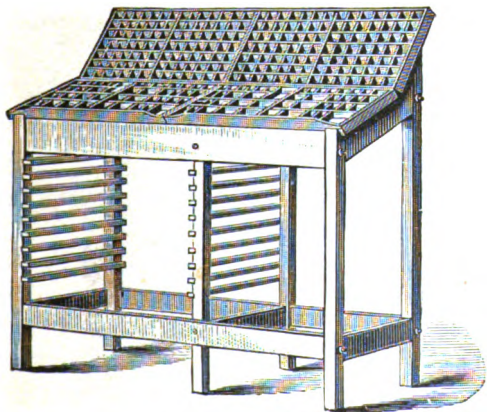

The Autocrat Stand and Galley Rack.



For Prices, see Price List.

xxxii

Cincinnati Type Foundry, 201 Vine St.

CASES.

Two-thirds Cap Case.

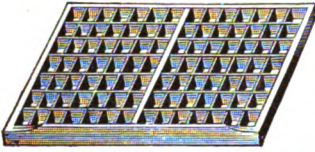

Two-thirds Lower Case.

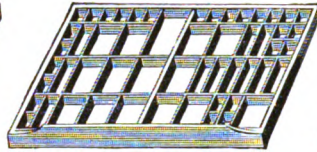

Two-thirds Job Case.

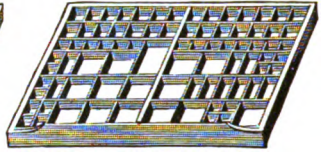

Cap Case, Plain.

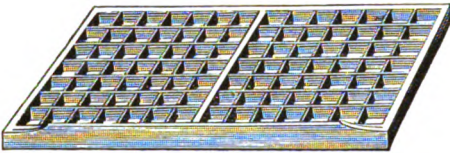

Lower Case, Plain.

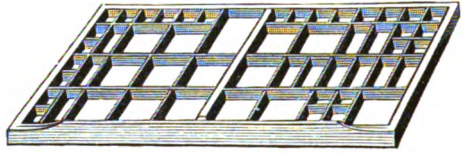

Triple Case.

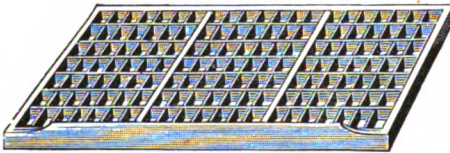

Job Case.

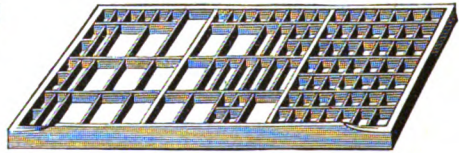

Labor-Saving Rule Case. Old Style.

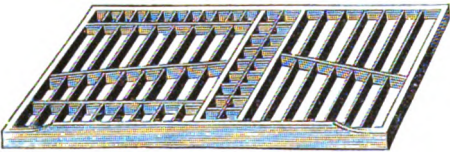

Labor-Saving Rule Case. New Style.

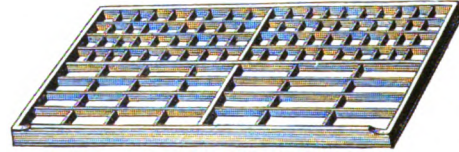

Quad and Space Case.

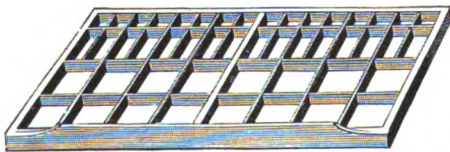
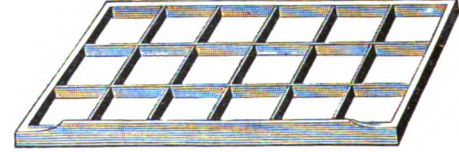
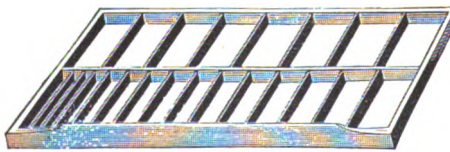

Figure Case.



Labor-Saving Lead Case.



Blank Case.



For Prices, see Price List.

xxxii

Cincinnati Type Foundry, 201 Vine St.



NEWS, BOOK AND JOB TYPE

BODIES.

ALL type cast by us is on the Didot or Point system, which has been adopted by all the principal type founders in the United States.

The system consists in grading the bodies from Nonpareil to Pica in six equal steps.

With our old bodies, the step from Brevier to Bourgeois was a very small one, and, to compensate for that, a very large step was made from Small Pica to Pica.

There is now, in the new system, the same difference between Minion and Brevier as between Brevier and Bourgeois, and this makes Bourgeois equal to Three-Line Excelsior, or Nonpareil and One-Half; Two-Line Bourgeois, the new Great Primer, being synonymous with three Nonpareils, Double Great Primer with Three-Line Pica, etc. Double English has been changed into Five-Line Nonpareil, and Double Paragon into Seven-Line Nonpareil, making the steps from Three-Line Nonpareil to Four-Line Pica by Nonpareils.

The new system also enlarges Long Primer to five-sixths of Pica, and the new Paragon, of course, is equal to two of the Long Primers, and is found to take on all those job letters formerly cast on Double Small Pica. Small Pica comes into the line, but as a book type only, and will be used as Roman and Italic, and not as a job type.

In making the changes, we have in stock large quantities of type cast on both systems, and patrons who have preferences, or those buying to match fonts they already have, can be accommodated. Those ordering sorts should be doubly careful to *send samples of type to be matched* with their orders.

The change will materially reduce the number of bodies in use, and simplify justification in the office.

SCOTCH SERIES.

PEARL (5 POINTS) No. 8.

THE mere communication of book knowledge is not the only object to keep in mind in constructing systems of academical education. However important the information we received from particular authors may be, and whatever improvements might be made in the methods of communicating it by a more strict examination, it should be observed, that these methods embrace the means, and not the ultimate object of education. They indeed tend to improve the power of memory and of the comprehensions, but they are never calculated to confer that penetration by means of which students generate new trains of thinking, and acquire the habit of estimating the ground of their judgment, and combining or expressing the information that has been obtained. In all respects, the lecture system is abcdefghijklmnopqrstuvwxyzabcdefghijklmnopqrstuvwxyz

NONFAREIL (6 POINTS) No. 8. Solid.

THE mere communication of book knowledge is not the only object to keep in mind in constructing a system of academical education. However important may be the information one received from some particular authors and whatever improvements might be made in various methods of communicating it by a strict examination, it should be observed that these methods embrace simply the means, and not the ultimate object of an education. They indeed tend to improve the power of memory and of comprehension, but they are not calculated to confer that penetration by means of which a student generates new trains of thinking, and acquires a habit of forming abcdefghijklmnopqrstuvwxyzabcdefghijklmnopqrstuvwxyz

MINION (7 POINTS) No. 8. Solid.

THE mere communication of a knowledge is not the only object to keep in mind in constructing good systems of academic education. However important the information received from some authors may be, and whatever improvement be made in the methods of communicating it by a strict examination it must now be observed that these methods embrace the means, and not the ultimate objects of our education. They indeed tend to improve the power of comprehension or abcdefghijklmnopqrstuvwxyzabcdefghijklmnopqrstuvwxyz

BREVIER (8 POINTS) No. 8. Solid.

THE mere communication of a knowledge is not the only object to be kept in our minds in constructing a good system of academic education. However important may be the information received from some particular author, and whatever improvement may be made in the methods of communicating it by a stricter examination, it should be said that these methods embrace the means, not abcdefghijklmnopqrstuvwxyzabcdefghijklmnopqrstuvwxyz

BOURGEOIS (9 POINTS) No. 8. Solid.

THE mere communication of knowledge is not the only object to be kept in mind when constructing systems of academical education. However important may be the information received from particular authors, and whatever improvement may be made in the method of communicating it by a more strict examination, it should abcdefghijklmnopqrstuvwxyzabcdefghijklmnopqrstuvwxyz

LONG PRIMER (10 POINTS) No. 8. Solid.

THE mere communication of a certain amount of knowledge is not the only object to keep in mind when forming a good system of academic education. However important may be the great information we can receive from some particular author, or the improvement abcdefghijklmnopqrstuvwxyzabcdefghijklmnopqrstuvwxyz

AGATE (5½ POINTS) No. 8.

THE mere communication of knowledge is not the only object to keep in our minds in constructing a system of academical education. However important may be the information we receive from any particular author, and whatever improvement may be made in the methods of communicating it by strict examinations, it should be observed that these methods embrace the means, not the ultimate object of our education. They, indeed, tend to improve the powers of memory and comprehension, but they are not calculated to confer that penetration by the means of which a student generates a train of thinking abcdefghijklmnopqrstuvwxyzabcdefghijklmnopqrstuvwxyz

NONFAREIL (6 POINTS) No. 8. Leaded.

THE mere communication of book knowledge is not the only object to keep in mind in constructing a system of academical education. However important may be the information one received from some particular authors and whatever improvements might be made in various methods of communicating it by a strict examination, it should be observed that these methods embrace simply the means, and not the ultimate object of an education. They indeed tend to improve the power of memory and of comprehension, but they are not calculated to confer

MINION (7 POINTS) No. 8. Leaded.

THE mere communication of a knowledge is not the only object to keep in mind in constructing good systems of academic education. However important the information received from some authors may be, and whatever improvement be made in the methods of communicating it by a strict examination it must now be observed that these methods embrace the means, and not the ultimate objects of our education. They indeed

BREVIER (8 POINTS) No. 8. Leaded.

THE mere communication of a knowledge is not the only object to be kept in our minds in constructing a good system of academic education. However important may be the information received from some particular author, and whatever improvement may be made in the methods of communicating it by a stricter examination, it should be said

BOURGEOIS (9 POINTS) No. 8. Leaded.

THE mere communication of knowledge is not the only object to be kept in mind when constructing systems of academical education. However important may be the information received from particular authors, and whatever information may be made in the method of communicating

LONG PRIMER (10 POINTS) No. 8. Leaded.

THE mere communication of a certain amount of knowledge is not the only object to keep in mind when forming a good system of academic education. However important may be the great information we can receive from some particular author, or the improvement

LARGE BOOK FACES.

LONG PRIMER (10 POINTS) No. 10. Solid.

THE mere communication of general knowledge is not the only object we should keep in our minds when thus engaged in constructing a system of academic education. However really important the information we receive from some particular author may be, and whatever improvement might be made in the plans of communicating abcdefghijklmnopqrstuvwxyzabcdefg

LONG PRIMER (10 POINTS) No. 11. Solid.

THE mere communication of book knowledge is not the one object to be kept in mind when constructing a system of academical education. However important information is received from a particular author, and whatever improvement might be made in ways of communicating it by a minute examination, there abcdefghijklmnopqrstuvwxyzabcde

SMALL PICA (11 POINTS) No. 11. Solid.

THE mere communication of book knowledge is not the only object to keep in mind in constructing a good plan of academic education. However important may be some information received from certain authors, and whatever improved method of communicating it may abcdefghijklmnopqrstuvwxyzabc

PICA (12 POINTS) No. 6. Solid.

THE mere communication of the book knowledge is not the only object to be kept in mind when constructing a better system of academical education. However important the information which we may obtain from reading the abcdefghijklmnopqrstuvwxyzabc

PICA (12 POINTS) No. 8. Solid.

THE mere communication of a knowledge is not the object to be kept in our minds when constructing good systems of academic education. However important the information we receive from particular author abcdefghijklmnopqrstuvwxyz

LONG PRIMER (10 POINTS) No. 10. Leaded.

THE mere communication of general knowledge is not the only object we should keep in our minds when thus engaged in constructing a system of academic education. However really important the information we receive from some particular author may be, and whatever improvement might be

LONG PRIMER (10 POINTS) No. 11. Leaded.

THE mere communication of book knowledge is not the one object to be kept in mind when constructing a system of academical education. However important information is received from a particular author, and whatever improvement might be made in ways of communicating

SMALL PICA (11 POINTS) No. 11. Leaded.

THE mere communication of book knowledge is not the only object to keep in mind in constructing a good plan of academic education. However important may be some information received from certain authors, and whatever improved method of communicating it may

PICA (12 POINTS) No. 6. Leaded.

THE mere communication of the book knowledge is not the only object to be kept in mind when constructing a better system of academical education. However important the information which we may obtain from reading the

PICA (12 POINTS) No. 8. Leaded.

THE mere communication of a knowledge is not the object to be kept in our minds when constructing good systems of academic education. However important the information we receive from particular author

AMERICAN SERIES.

AGATE (5½ POINTS) No. 12. Solid.

THE mere communication of a knowledge is not the only object to be kept in our minds in constructing a system of academical education. However important the information we receive from a particular author may be, and whatever improvements might be made in the method of communicating it by a more strict examination, it must be observed that such methods embrace only the means, not the ultimate objects of education. They, indeed, tend to improve the power of comprehension and of memory, but they are little calculated to confer that penetration by the means of which the student generates new trains of thinking and acquires the habit of estimating the grounds of his judgment, and of combining and expressing the information that has been obtained. In every respect the lecture system, combined with reading, is more
abcdefghijklmnopqrstuvwxyzabcdefghijklmnopqrstuvwxyz

NONPAREIL (6 POINTS) No. 12. Solid.

THE mere communication of knowledge is not the sole object to be kept in mind when constructing a better system of academical education. However important the information that we received from some particular authors might be, and whatever improvements might be made in their methods of communicating it, by more strict examination, it must be observed that such methods embrace the means, and not the ultimate objects of education. They tend to improve the powers of memory and comprehension, but are never calculated to confer that penetration by means of which the students generate trains of thinking and acquire the habit of estimating the grounds of their judgment, and
abcdefghijklmnopqrstuvwxyzabcdefghijklmnopqrstuvwxyz

MINION (7 POINTS) No. 12. Solid.

THE mere communication of a knowledge is not the only object to be kept in mind when constructing any good system of academical education. However important may be the information we received from some authors, and whatever improvement is made in their method of communicating it, by more strict examination, it must be observed that such methods embrace but the means, and not the ultimate objects of education. They indeed tend to improve the power of comprehension and memory but are not calculated to confer that penetration by the means of which they
abcdefghijklmnopqrstuvwxyzabcdefghijklmnopqrstuvwxyz

BREVIER (8 POINTS) No. 12. Solid.

THE mere communication of knowledge is not the only object to be kept in mind when constructing systems of academical education. However important might be the information received from particular authors and whatever improvement may be made in the method of communicating it by more strict examinations, it must be observed that these methods embrace the means, and not the ultimate object of our education. They indeed tend to improve
abcdefghijklmnopqrstuvwxyzabcdefghijklmnopqrstuvwxyz

BOURGEOIS (9 POINTS) No. 12. Solid.

THE mere communication of scientific knowledge is not the only object to be kept in mind in constructing a system of good academic education. However important may be the information we receive from a particular author, and whatever improvements may be made in the method of communicating it by more minute examination, it must be observed that these methods embrace
abcdefghijklmnopqrstuvwxyzabcdefghijklmnopqrstuvwxyz

AGATE (5½ POINTS) No. 12. Leaded.

THE mere communication of a knowledge is not the only object to be kept in our minds in constructing a system of academical education. However important the information we receive from a particular author may be, and whatever improvements might be made in the method of communicating it by a more strict examination, it must be observed that such methods embrace only the means, not the ultimate objects of education. They, indeed, tend to improve the power of comprehension and of memory, but they are little calculated to confer that penetration by the means of which the student generates new trains of thinking and acquires the habit of estimating the grounds of

NONPAREIL (6 POINTS) No. 12. Leaded.

THE mere communication of knowledge is not the sole object to be kept in mind when constructing a better system of academical education. However important the information that we received from some particular authors might be, and whatever improvements might be made in their methods of communicating it, by more strict examination, it must be observed that such methods embrace the means, and not the ultimate objects of education. They tend to improve the powers of memory and comprehension, but are never calculated to confer

MINION (7 POINTS) No. 12. Leaded.

THE mere communication of a knowledge is not the only object to be kept in mind when constructing any good system of academical education. However important may be the information we received from some authors, and whatever improvement is made in their method of communicating it, by more strict examination, it must be observed that such methods embrace but the means and not the ultimate objects of education. They indeed tend to improve the power of comprehension

BREVIER (8 POINTS) No. 12. Leaded.

THE mere communication of knowledge is not the only object to be kept in mind when constructing systems of academical education. However important might be the information received from particular authors and whatever improvement may be made in the method of communicating it by more strict examinations, it must be observed that these methods embrace the means, and not the ultimate object of our

BOURGEOIS (9 POINTS) No. 12. Leaded.

THE mere communication of scientific knowledge is not the only object to be kept in mind in constructing a system of good academic education. However important may be the information we receive from a particular author, and whatever improvements may be made in the method of communicating it by more minute examination, it must be

OLD STYLE SERIES.

NONPAREIL (6 POINTS) No. 13. Solid.

THE mere communication of knowledge is not the only object to be kept in mind in constructing any good systems of academical education. However important the information we receive from certain authors may be, and whatever improvements may be made in the methods of communicating it by a more strict examination, it must be observed that such methods embrace the means, not the ultimate object of our education. They tend to improve the power of comprehension and memory, but are not calculated to confer that penetration by the means of which students generate trains of thinking and acquire a habit of estimating the grounds of their judgment, and of combining or expressing certain
abcdefghijklmnopqrstuvwxyabcdefghijklmnopqr

BREVIER (8 POINTS) No. 13. Solid.

THE mere communication of a knowledge is not the only object to keep in the mind in constructing good systems of academic education. However important may be the information we received from a particular author, and whatever improvements may be made in the method of communicating it by a strict examination, it must now be observed that such methods embrace only the means, not the ultimate objects of our education. They, indeed, tend to improve
abcdefghijklmnopqrstuvwxyabcdefghijklmnopkl

LONG PRIMER (10 POINTS) No. 13. Solid.

THE mere communication of varied knowledge is not the only object to be kept in our minds in constructing new systems of academic education. However important the information we received from particular authors may be, and whatever improvement is made in modes of communicating it by strict examination, it must now
abcdefghijklmnopqrstuvwxyabcdefghijklmnopde

SMALL PICA (11 POINTS) No. 13. Solid.

THE mere communication of our knowledge is not the only object to be kept in mind in constructing a system of academic education. However important might be the information received from certain authors, and whatever attempted improvements on the methods of
abcdefghijklmnopqrstuvwxyabcdefghijklmnop

PICA (12 POINTS) No. 13. Solid.

THE mere communication of book knowledge is not all we should keep in mind when we are constructing new systems of academic education. How ever important the teachings of particular authors might be
abcdefghijklmnopqrstuvwxyabcdefghijklmnop

NONPAREIL (6 POINTS) No. 13. Leaded.

THE mere communication of knowledge is not the only object to be kept in mind in constructing any good systems of academical education. However important the information we receive from certain authors may be, and whatever improvements may be made in the methods of communicating it by a more strict examination, it must be observed that such methods embrace the means, not the ultimate object of our education. They tend to improve the power of comprehension and memory, but are not calculated to confer that penetration by the means

BREVIER (8 POINTS) No. 13. Leaded.

THE mere communication of a knowledge is not the only object to keep in the mind in constructing good systems of academic education. However important may be the information we received from a particular author, and whatever improvements may be made in the method of communicating it by a strict examination, it must now be observed that such methods embrace only the means, not the ultimate objects of our

LONG PRIMER (10 POINTS) No. 13. Leaded.

THE mere communication of varied knowledge is not the only object to be kept in our minds in constructing new systems of academic education. However important the information we received from particular authors may be, and whatever improvement is made in modes of communicating

SMALL PICA (11 POINTS) No. 13. Leaded.

THE mere communication of our knowledge is not the only object to be kept in mind in constructing a system of academic education. However important might be the information received from certain authors, and whatever attempted improvements on the methods of

PICA (12 POINTS) No. 13. Leaded.

THE mere communication of book knowledge is not all we should keep in mind when we are constructing new systems of academic education. How ever important the teachings of particular authors might be

LATEST BOOK FACES.

NONPAREIL (6 POINTS) No. 14. Solid.

THE mere communication of a knowledge is not the only object to keep in mind in constructing a good system of academic education. However important the information we receive from some author may be, and whatever improvement may be made in the method of communicating it, by a minute examination, it must now be observed that such methods embrace the means, and not the ultimate object of our education. They tend abcdefghijklmnopqrstuvwxyzabcdefghijklmnop

MINION (7 POINTS) No. 14. Solid.

THE mere communication of a knowledge is not the only object to be kept in our minds in constructing systems of academic education. However important the information derived from certain authors may be, and whatever improvements may be made in the methods of communicating it, by strict examinations, it must be observed that such methods only abcdefghijklmnopqrstuvwxyzabcdefghijklmnop

BREVIER (8 POINTS) No. 14. Solid.

THE mere communication of knowledge is not the only object to keep in mind in constructing good systems of academical education. However important might be the information received from particular authors, and whatever improvements are made in the method of communicating it abcdefghijklmnopqrstuvwxyzabcdefghijklmnop

BOURGEOIS (9 POINTS) No. 14. Solid.

THE mere communication of scientific knowledge is not the only object to be kept in mind when constructing good systems of academical education. However important the information derived from particular authors might be, and abcdefghijklmnopqrstuvwxyzabcdefghijklmnop

LONG PRIMER (10 POINTS) No. 14. Solid.

THE mere communication of book knowledge is not the only object to be kept in mind in constructing a new system of academic education. However important may be certain information we have received from abcdefghijklmnopqrstuvwxyzabcdefghijklmnop

SMALL PICA (11 POINTS) No. 14. Solid.

THE mere communication of our knowledge is not the only object to keep in mind in constructing systems of academical education. However important might be the abcdefghijklmnopqrstuvwxyzabcdefghijklmnop

PICA (12 POINTS) No. 14. Solid.

THE mere communication of a knowledge is not the one idea to keep in our minds when we are constructing a new system abcdefghijklmnopqrstuvwxyzabcdefghijklmnop

NONPAREIL (6 POINTS) No. 14. Leaded.

THE mere communication of a knowledge is not the only object to keep in mind in constructing a good system of academic education. However important the information we receive from some author may be, and whatever improvement may be made in the method of communicating it, by a minute examination, it must now be observed that such methods embrace the means, and not

MINION (7 POINTS) No. 14. Leaded.

THE mere communication of a knowledge is not the only object to be kept in our minds in constructing systems of academic education. However important the information derived from certain authors may be, and whatever improvements may be made in the methods of communicating it, by strict examinations

BREVIER (8 POINTS) No. 14. Leaded.

THE mere communication of knowledge is not the only object to keep in mind in constructing good systems of academical education. However important might be the information received from particular authors, and whatever improvement are

BOURGEOIS (9 POINTS) No. 14. Leaded.

THE mere communication of scientific knowledge is not the only object to be kept in mind when constructing good systems of academical education. However important the information derived from particular authors might be, and

LONG PRIMER (10 POINTS) No. 14. Leaded.

THE mere communication of book knowledge is not the only object to be kept in mind in constructing a new system of academic education. However important may be certain information we have received from

SMALL PICA (11 POINTS) No. 14. Leaded.

THE mere communication of our knowledge is not the only object to keep in mind in constructing systems of academical education. However important might be the

PICA (12 POINTS) No. 14. Leaded.

THE mere communication of a knowledge is not the one idea to keep in our minds when we are constructing a new system

BROADGAUGE SERIES.

AGATE (5½ POINTS) No. 15. Solid.

THE mere communication of knowledge is not the only object to be kept in our minds in constructing a good system of academical education. However important might be the information that we derive from some authors, and whatever improvement is made in the method of communicating it, by strict examination, it must be observed that such method embraces the means and not the ultimate object of education. They indeed tend to improve the power of comprehension and of memory, but they are not calculated to confer that penetration by the means of which a student generates new trains of thinking and acquires the habit of estimating the grounds of his judgment, and combining or expressing certain information that has been obtained. In all respects the lecture system combined with reading is better
abcdefghijklmnopqrstuvwxyzabcdefghijklmno

NONPAREIL (6 POINTS) No. 15. Solid.

THE mere communication of book knowledge is not the only object to be kept in mind when constructing a system of academic education. However important may be that information we received from any particular authors, and whatever improvement might be made in the methods of communicating it, by a very strict examination, it should be observed that those methods embrace only the means and not the ultimate objects of our education. They truly tend to improve the powers of memory and of comprehension, but are not calculated to give that penetration by means of which a student generates new trains of thought, and acquires habits of estimating the grounds of judgment
abcdefghijklmnopqrstuvwxyzabcdefghijklm

MINION (7 POINTS) No. 15. Solid.

THE mere communication of knowledge is not the only object to be kept in mind when constructing a system of academic education. However important might be the information received from particular authors, and whatever improvement may be made in the modes of communicating it by a more minute examination, it must be observed that these methods embrace the means, and not the ultimate object of our education. They tend to improve the power of memory and of comprehension, but they are not calculated to confer that
abcdefghijklmnopqrstuvwxyzabcdefghijkl

BREVIER (8 POINTS) No. 15. Solid.

THE mere communication of a general knowledge is not the only object to be kept in mind in constructing a system of good academic education. However important the information we received from some particular authors might be, and whatever improvements might be made in the method of communicating it by a more strict examination, it may always be observed that such methods embrace the means, and not the entire
abcdefghijklmnopqrstuvwxyzabcdefghijkl

BOURGEOIS (9 POINTS) No. 15. Solid.

THE mere communication of book knowledge is not the only object to keep in our minds in constructing a new system of academic education. However important the particular information we derive from certain authors may be, and whatever late improvements may be made in the methods of communicating it, by a strict examination, it must ever be
abcdefghijklmnopqrstuvwxyzabede

AGATE (5½ POINTS) No. 15. Leaded.

THE mere communication of knowledge is not the only object to be kept in our minds in constructing a good system of academical education. However important might be the information that we derive from some authors, and whatever improvement is made in the method of communicating it, by strict examination, it must be observed that such method embraces the means and not the ultimate object of education. They indeed tend to improve the power of comprehension and of memory, but they are not calculated to confer that penetration by the means of which a student generates new trains of thinking and acquires the habit of estimating the grounds of

NONPAREIL (6 POINTS) No. 15. Leaded.

THE mere communication of book knowledge is not the only object to be kept in mind when constructing a system of academic education. However important may be that information we received from any particular authors, and whatever improvement might be made in the methods of communicating it, by a very strict examination, it should be observed that those methods embrace only the means and not the ultimate objects of our education. They truly tend to improve the powers of memory and of comprehension, but are not calculated to give

MINION (7 POINTS) No. 15. Leaded.

THE mere communication of knowledge is not the only object to be kept in mind when constructing a system of academic education. However important might be the information received from particular authors, and whatever improvement may be made in the modes of communicating it by a more minute examination, it must be observed that these methods embrace the means, and not the ultimate object of our education. They tend to improve the

BREVIER (8 POINTS) No. 15. Leaded.

THE mere communication of a general knowledge is not the only object to be kept in mind in constructing a system of good academic education. However important the information we received from some particular authors might be and whatever improvements might be made in the method of communicating it by a more strict examination, it may always be observed that such methods

BOURGEOIS (9 POINTS) No. 15. Leaded.

THE mere communication of book knowledge is not the only object to keep in our minds in constructing a new system of academic education. However important the particular information we derive from certain authors may be, and whatever late improvements may be made in the methods of communicating it, by a

MODERN OLD STYLE.

NONPAREIL (6 POINTS) No. 13.

Quousque tandem abutere, Catalini, patientia nostra? quamdiu etiam furor iste tuus nos eludet? et quem ad finem sese effrenata jactabit audacia? nihilne te nocturnum præsidium palatii, nihil urbis vigilæ, nihil timor populi, nihil concursus bonorum omnium, nihil hic munitissimus habendi senatum locus, nihil horum ora vultusque moverunt? patere tua consilia non sentis? constrictam jam horum omnium conscientia teneri conjurationem tuam non vides? quid proxima, quid superiore nocte egeris, ubi fueris, quos convocaveris, quid consilii ceperis, quem nostrum ignorare arbitris? O tempora! O mores! Senatus hæc intelligit, consuli videt, hic tamen vivit. Vivit! immo verio etiam in senatum venit: fit publici consilii particeps; notat et designat oculis ad cædem unumquemque nostrum. Nos autem viri fortes, satisfacere reipublicæ videmur, sti istius furiosem ac tela vitemus. Ad mortem te, Catalina, duci jussu consulis, impridem oportebat: in te conferri, pestem istem, quam tuis in nos omnes jandiū machinaris. An verio vir amplissimus, Publius Scipio, pontifex maximus Tiberium Gracchum, mediocritor labefactantum statum reipublicæ, privatus interfecit. Catalinam

Quousque tandem abutere Catalini, patientia nostra? quamdiu etiam furor iste tuus nos eludet? quem ad finem sese effrenata jactabit audacia? nihilne te nocturnum præsidium palatii, nihil urbis vigilæ

BREVIER (8 POINTS) No. 13.

Quousque tandem abutere, Catalina, patientia nostra? quamdiu etiam furor iste tuus nos eludet? quem ad finem sese effrenata jactabit audacia? nihilne te nocturnum præsidium palatii, nihil urbis vigilæ, nihil timor populi, nihil concursus bonorum omnium, nihil hic munitissimus habendi senatum locus, nihil horum ora vultusque moverunt? patere tua consilia non sentis? constrictam jam horum omnium conscientiam teneri conjurationem tuam non vides? quid proxima quid superiore nocte egeris ubi fueris, quos convocaveris, quid consilii ceperis, quem nostrum ignorare arbitraris? O tempora! O mores! Senatus hæc intelligit, consul videt, hic tamen vivit. Vivit! imo vero etiam in senatum venit; fit publici consilii particeps; notat et designat oculis

Quousque tandem abutere, Catalina, patientia nostra? quamdiu etiam furor iste tuus nos eludet? quem ad finem sese effrenata jactabit audacia? nihilne te nocturnum

LONG PRIMER (10 POINTS) No. 13.

Quousque tandem abutere, Catalina, patientia nostra? quamdiu etiam furor iste tuus nos eludet? quem ad finem sese effrenata jactabit audacia? nihilne te nocturnum præsidium palatii, nihil urbis vigilæ, nihil timor populi, nihil concursus bonorum omnium, nihil hic munitissimus habendi senatum locus, nihil horum ora vultusque moverunt? patere tua consilia non sentis? constrictam jam horum omnium conscientiam teneri conjurationem tuam non vides? quid proxima, quid superiore nocte egeris ubi fueris, quos convocaveris, quid consilii ceperis, quem nostrum ignorare arbitraris? O tempora! O mores! Senatus hæc intelligit, consul videt, hic tamen vivit. Vivit! imo vero etiam in senatum venit; fit publici consilii particeps; notat et designat oculis

Quousque tandem abutere, Catalina, patientia nostra? quamdiu etiam furor iste tuus nos eludet? quem ad finem sese effrenata jactabit aud

SMALL PICA (11 POINTS) No. 13.

Quousque tandem abutere, Catalina, patientia nostra? quamdiu etiam furor iste tuus nos eludet? quem ad finem sese effrenata jactabit audacia? nihilne te nocturnum præsidium palatii, nihil urbis vigilæ, nihil timor populi, nihil concursus bonorum omnium, nihil hic munitissimus habendi senatum locus, nihil horum ora vultusque moverunt? patere tua consilia non sentis? constrictam jam horum omnium conscientiam teneri conjurationem tuam non vides? quid proxima, quid superiore nocte egeris ubi fueris, quos convocaveris, quid consilii ceperis, quem nostrum ignorare arbitraris? O tempora! O mores! Senatus hæc intelligit, consul videt, hic tamen vivit. Vivit! imo vero etiam in senatum venit; fit publici consilii particeps; notat et designat oculis

Quousque tandem abutere, Catalina, patientia nostra? quamdiu etiam furor iste tuus nos eludet? quem ad finem sese effrenata jactabit

PICA (12 POINTS) No. 13.

Quousque tandem abutere, Catalina, patientia nostra? quamdiu etiam furor iste tuus nos eludet? quem ad finem sese effrenata jactabit audacia? nihilne te nocturnum præsidium palatii, nihil urbis vigilæ, nihil timor populi, nihil concursus bonorum omnium, nihil hic munitissimus habendi senatum locus

Quousque tandem abutere Catalina, patientia nostra? quamdiu etiam furor iste tuus nos eludet? quem ad finem sese

PEARL (5 POINTS) No. 8.

Quousque tandem abutere, Catilina, patientia nostra? quamdiu etiam furor este tuus nos eludet? quem ad finem sese effrenata iactabit audacia? nihilne te nocturnum presidium palatii, nihil urbis vigilie, nihil concursus bonorum omnium, nihil hic munitissimum habendi senatum locum, nihil horum ora vultusque moverunt? patere tua consilia tu non sentis? constricta jam horum omnium conscientia teneri conjunctionem tuam non vides? quid proxima, quid superioris nocte egeris, ubi fueris, quos convocaveris, quid consilii ceperis, quem nostrum ignorare arbitraris? O tempora! O mores! Senatus hæc intelligit, consul videt, hic tamen vivet. Vivet! immo vero etiam in senatum venit: fit publici concilii participes: notat et designat oculis ad eodem unumquemque nostrum. Nos autem viri fortes satisfacere republice videntur, si istius furorem ac tela vitemus. Ad mortem te, Catilina, duci jussu consilii, jam pridem oportebat: in te conferri pestem istem, quam tu in nos omnes jamdiu machinaris. An vero vir amplissimus, Publius Scipio, pontifex maximus, Tiberium Gracchum, medicorum labefactantem statum republice, privatus interfecit: Catilinam orbem terrarum cæde atque incendio vastare cupientium nos consules perferemus? Nam illa nimis antiqua, prætereo, quod Caius Servilius Ahala, Spurius Mælius, novis rebus studentem manu sua occidit. Fuit, fuit ista quondam in hac republice virtus viri fortes acroribus supplicis civem perniciosum, quam acerbissimum hostem coercerent. Habemus senatus consultum in te Catilina, vehemens et grave: non deest republice consilium, neque auctoritas hujus ordinis: nos, nos, dico aperte, nos consules desumus. Decrevit quondam senatus ut Lucius Optimus consul videret, quid republica detrimenti caperet; nox nulla intercessit: interfectus est propter quædam seditionem suspiciones Gracchus, clarissimo patere, avo majioribus? occisus aut cum liberis Marco Fluvius, consularis. Simili senatus consulto Cæio Mario et Lucio Valerio, permessa est republica: unum diem postea Lucio Saturnini tribuni plebis, et Cæli Servilii prætoris mortem republice poena renormata est: Ad nos vice simul jam diem par tinur habecere aciem horum auctoritatis. Habemus nostra cum dignitario confusa im hujus modi senatus conferencia et

A B C D E F G H I J K L M N O P Q R S T U V W X Y Z

ABCDEF GHIJKLMNOPQRSTU VWXYZ.

1234567890

abcdefg hijklmnopqrstuvwxy z

1234567890

Quousque tandem abutere, Catilina, patientia nostra? quamdiu etiam furor este tuus nos eludet? quem ad finem sese effrenata iactabit audacia? nihilne te nocturnum presidium palatii, nihil urbis vigilie, nihil concursus bonorum omnium, nihil hic munitissimum habendi senatum locum, nihil horum ora vultusque moverunt? patere tua consilia tu non sentis? constricta jam horum omnium conscientia teneri conjunctionem tuam non vides? quid proxima, quid superioris nocte egeris, ubi fueris, quos convocaveris, quid consilii ceperis, quem nostrum ignorare arbitraris? O tempora! O mores! Senatus hæc intelligit, consul videt, hic tamen vivet. Vivet! immo vero etiam in senatum venit: fit publici concilii participes: notat et designat oculis ad eodem unumquemque nostrum. Nos autem viri fortes satisfacere republice videntur, si istius furorem ac tela vitemus. Ad mortem te, Catilina, duci jussu consilii, jam pridem oportebat: in te conferri pestem istem, quam tu in nos omnes jamdiu machinaris. An vero vir amplissimus, Publius Scipio, pontifex maximus, Tiberium Gracchum, medicorum labefactantem statum republice, privatus interfecit: Catilinam orbem terrarum cæde atque incendio vastare cupientium nos consules perferemus? Nam illa nimis antiqua, prætereo, quod Caius Servilius Ahala, Spurius Mælius, novis rebus studentem manu sua occidit. Fuit, fuit ista quondam in hac republice virtus viri fortes acroribus supplicis civem perniciosum, quam acerbissimum hostem coercerent. Habemus senatus consultum in te Catilina, vehemens et grave: non deest republice consilium, neque auctoritas hujus ordinis: nos, nos, dico aperte, nos consules desumus. Decrevit quondam senatus ut Lucius Optimus consul videret, quid republica detrimenti caperet; nox nulla intercessit: interfectus est propter quædam seditionem suspiciones Gracchus, clarissimo patere, avo majioribus? occisus aut cum liberis Marco Fluvius, consularis. Simili senatus consulto Cæio Mario et Lucio Valerio, permessa est republica: unum diem postea Lucio Saturnini tribuni plebis, et Cæli Servilii prætoris mortem republice poena renormata est: Ad nos vice simul jam diem par tinur habecere aciem horum auctoritatis. Habemus nostra cum dignitario confusa im hujus modi senatus conferencia et

AGATE (5½ POINTS) No. 8.

Quousque tandem abutere, Catilina, patientia nostra? quamdiu etiam furor iste tuus nos eludet? quem ad finem sese effrenata iactabit audacia? nihilne te nocturnum presidium palatii, nihilne urbis vigilie, nihil concursus bonorum omnium, nihil hic munitissimum habendi senatum locum, nihil horum ora vultusque moverunt? patere tua consilia tu non sentis? constricta jam horum omnium conscientia teneri conjunctionem tuam non vides? quid proxima, quid superioris nocte egeris, ubi fueris, quos convocaveris, quid consilii ceperis, quem nostrum ignorare arbitraris? O tempora! O mores! Senatus hæc intelligit, consul videt, hic tamen vivet. Vivet! immo vero etiam in senatum venit: fit publici concilii participes: notat et designat oculis ad eodem unumquemque nostrum. Nos autem viri fortes satisfacere republice videntur, si istius furorem ac tela vitemus. Ad mortem te, Catilina, duci jussu consilii, jam pridem oportebat: in te conferri pestem istem, quam tu in nos omnes jamdiu machinaris. An vero vir amplissimus, Publius Scipio, pontifex maximus, Tiberium Gracchum, medicorum labefactantem statum republice, privatus interfecit: Catilinam orbem terrarum cæde atque incendio vastare cupientium nos consules perferemus? Nam illa nimis antiqua, prætereo, quod Caius Servilius Ahala, Spurius Mælius, novis rebus studentem manu sua occidit. Fuit, fuit ista quondam in hac republice virtus viri fortes acroribus supplicis civem perniciosum, quam acerbissimum hostem coercerent. Habemus senatus consultum in te Catilina, vehemens et grave: non deest republice consilium, neque auctoritas hujus ordinis: nos, nos, dico aperte, nos consules desumus. Decrevit quondam senatus ut Lucius Optimus consul videret, quid republica detrimenti caperet; nox nulla intercessit: interfectus est propter quædam seditionem

A B C D E F G H I J K L M N O P Q R S T U V W X Y Z

ABCDEF GHIJKLMNOPQRSTU VWXYZ

1234567890

abcdefg hijklmnopqrstuvwxy z

1234567890

Quousque tandem abutere, Catilina, patientia nostra? quamdiu etiam furor iste tuus nos eludet? quem ad finem sese effrenata iactabit audacia? nihilne te nocturnum presidium palatii, nihil urbis vigilie, nihil concursus bonorum omnium, nihil hic munitissimum habendi senatum locum, nihil horum ora vultusque moverunt? patere tua consilia tu non sentis? constricta jam horum omnium conscientia teneri conjunctionem tuam non vides? quid proxima, quid superioris nocte egeris, ubi fueris, quos convocaveris, quid consilii ceperis, quem nostrum ignorare arbitraris? O tempora! O mores! Senatus hæc intelligit, consul videt, hic tamen vivet. Vivet! immo vero etiam in senatum venit: fit publici concilii participes: notat et designat oculis ad eodem unumquemque nostrum. Nos autem viri fortes satisfacere republice videntur, si istius furorem ac tela vitemus. Ad mortem te, Catilina, duci jussu consilii, jam pridem oportebat: in te conferri pestem istem, quam tu in nos omnes jamdiu machinaris. An vero vir amplissimus, Publius Scipio, pontifex maximus, Tiberium Gracchum, medicorum labefactantem statum republice, privatus interfecit: Catilinam orbem terrarum cæde atque incendio vastare cupientium nos consules perferemus? Nam illa nimis antiqua, prætereo, quod Caius Servilius Ahala, Spurius Mælius, novis rebus studentem manu sua occidit. Fuit, fuit ista quondam in hac republice virtus viri fortes acroribus supplicis civem perniciosum, quam acerbissimum hostem coercerent. Habemus senatus consultum in te Catilina, vehemens et grave: non deest republice consilium, neque auctoritas hujus ordinis: nos, nos, dico aperte, nos consules desumus. Decrevit quondam senatus ut Lucius Optimus consul videret, quid republica detrimenti caperet; nox nulla intercessit: interfectus est propter quædam seditionem

AGATE (5½ POINTS) No. 12.

Quousque tandem abutere, Catilina, patientia nostra? quamdiu etiam furor iste tuus nos eludet? quem ad finem sese effrenata iactabit audacia? nihilne te nocturnum presidium palatii, nihil urbis vigilie, nihil concursus bonorum omnium, nihil hic munitissimum habendi senatum locum, nihil horum ora vultusque moverunt? patere tua consilia tu non sentis? constricta jam horum omnium conscientia teneri conjunctionem tuam non vides? quid proxima, quid superioris nocte egeris, ubi fueris, quos convocaveris, quid consilii ceperis, quem nostrum ignorare arbitraris? O tempora! O mores! Senatus hæc intelligit, consul videt, hic tamen vivet. Vivet! immo vero etiam in senatum venit: fit publici concilii participes: notat et designat oculis ad eodem unumquemque nostrum. Nos autem viri fortes satisfacere republice videntur, si istius furorem ac tela vitemus. Ad mortem te, Catilina, duci jussu consilii, jam pridem oportebat: in te conferri pestem istem, quam tu in nos omnes jamdiu machinaris. An vero vir amplissimus, Publius Scipio, pontifex maximus, Tiberium Gracchum, medicorum labefactantem statum republice, privatus interfecit: Catilinam orbem terrarum cæde atque incendio vastare cupientium nos consules perferemus? Nam illa nimis antiqua, prætereo, quod Caius Servilius Ahala, Spurius Mælius, novis rebus studentem manu sua occidit. Fuit, fuit ista quondam in hac republice virtus viri fortes acroribus supplicis civem perniciosum, quam acerbissimum hostem coercerent. Habemus senatus consultum in te Catilina, vehemens et grave: non deest republice consilium, neque auctoritas hujus ordinis: nos, nos, dico aperte, nos consules desumus. Decrevit quondam senatus cons

A B C D E F G H I J K L M N O P Q R S T U V W X Y Z

ABCDEF GHIJKLMNOPQRSTU VWXYZ

1234567890

abcdefg hijklmnopqrstuvwxy z

1234567890

Quousque tandem abutere, Catilina patientia nostra? quamdiu etiam furor iste tuus nos eludet? quem ad finem sese effrenata iactabit audacia? nihilne te nocturnum presidium palatii, nihil urbis vigilie, nihil concursus bonorum omnium, nihil hic munitissimum habendi senatum locum, nihil horum ora vultusque moverunt? patere tua consilia tu non sentis? constricta jam horum omnium conscientia teneri conjunctionem tuam non vides? quid proxima, quid superioris nocte egeris, ubi fueris, quos convocaveris, quid consilii ceperis, quem nostrum ignorare arbitraris? O tempora! O mores! Senatus hæc intelligit, consul videt, hic tamen vivet. Vivet! immo vero etiam in senatum venit: fit publici concilii participes: notat et designat oculis ad eodem unumquemque nostrum. Nos autem viri fortes satisfacere republice videntur, si istius furorem ac tela vitemus. Ad mortem te, Catilina, duci jussu consilii, jam pridem oportebat: in te conferri pestem istem, quam tu in nos omnes jamdiu machinaris. An vero vir amplissimus, Publius Scipio, pontifex maximus, Tiberium Gracchum, medicorum labefactantem statum republice, privatus interfecit: Catilinam orbem terrarum cæde atque incendio vastare cupientium nos consules perferemus? Nam illa nimis antiqua, prætereo, quod Caius Servilius Ahala, Spurius Mælius, novis rebus studentem manu sua occidit. Fuit, fuit ista quondam in hac republice virtus viri fortes acroribus supplicis civem perniciosum, quam acerbissimum hostem coercerent. Habemus senatus consultum in te Catilina, vehemens et grave: non deest republice consilium, neque auctoritas hujus ordinis: nos, nos, dico aperte, nos consules desumus. Decrevit quonda

AGATE (5½ POINTS) No. 15.

Quousque tandem abutere, Catilina, patientia nostra? quamdiu etiam furor iste tuus nos eludet? quem ad finem sese effrenata iactabit audacia? nihilne te nocturnum presidium palatii, nihil urbis vigilie, nihil concursus bonorum omnium, nihil hic munitissimum habendi senatum locum, nihil horum ora vultusque moverunt? patere tua consilia tu non sentis? constricta jam horum omnium conscientia teneri conjunctionem tuam non vides? quid proxima, quid superioris nocte egeris, ubi fueris, quos convocaveris, quid consilii ceperis, quem nostrum ignorare arbitraris? O tempora! O mores! Senatus hæc intelligit, consul videt, hic tamen vivet. Vivet! immo vero etiam in senatum venit: fit publici concilii participes: notat et designat oculis ad eodem unumquemque nostrum. Nos autem viri fortes satisfacere republice videntur, si istius furorem ac tela vitemus. Ad mortem te, Catilina, duci jussu consilii, jam pridem oportebat: in te conferri pestem istem, quam tu in nos omnes jamdiu machinaris. An vero vir amplissimus, Publius Scipio, pontifex maximus, Tiberium Gracchum, medicorum labefactantem statum republice, privatus interfecit: Catilinam orbem terrarum cæde atque incendio vastare cupientium nos consules perferemus? Nam illa nimis antiqua, prætereo, quod Caius Servilius Ahala, Spurius Mælius, novis rebus studentem manu sua occidit. Fuit, fuit ista quondam in hac republice virtus viri fortes acroribus supplicis civem perniciosum, quam acerbissimum hostem coercerent. Habemus senatus consultum in te Catilina, vehemens et grave: non deest republice consilium, neque auctoritas hujus ordinis: nos, nos, dico aperte, nos consules desumus. Decrevit quonda

A B C D E F G H I J K L M N O P Q R S T U V W X Y Z

ABCDEF GHIJKLMNOPQRSTU VWXYZ

1234567890

abcdefg hijklmnopqrstuvwxy z

1234567890

Quousque tandem abutere, Catilina patientia nostra? quamdiu etiam furor iste tuus nos eludet? quem ad finem sese effrenata iactabit audacia? nihilne te nocturnum presidium palatii, nihil urbis vigilie, nihil concursus bonorum omnium, nihil hic munitissimum habendi senatum locum, nihil horum ora vultusque moverunt? patere tua consilia tu non sentis? constricta jam horum omnium conscientia teneri conjunctionem tuam non vides? quid proxima, quid superioris nocte egeris, ubi fueris, quos convocaveris, quid consilii ceperis, quem nostrum ignorare arbitraris? O tempora! O mores! Senatus hæc intelligit, consul videt, hic tamen vivet. Vivet! immo vero etiam in senatum venit: fit publici concilii participes: notat et designat oculis ad eodem unumquemque nostrum. Nos autem viri fortes satisfacere republice videntur, si istius furorem ac tela vitemus. Ad mortem te, Catilina, duci jussu consilii, jam pridem oportebat: in te conferri pestem istem, quam tu in nos omnes jamdiu machinaris. An vero vir amplissimus, Publius Scipio, pontifex maximus, Tiberium Gracchum, medicorum labefactantem statum republice, privatus interfecit: Catilinam orbem terrarum cæde atque incendio vastare cupientium nos consules perferemus? Nam illa nimis antiqua, prætereo, quod Caius Servilius Ahala, Spurius Mælius, novis rebus studentem manu sua occidit. Fuit, fuit ista quondam in hac republice virtus viri fortes acroribus supplicis civem perniciosum, quam acerbissimum hostem coercerent. Habemus senatus consultum in te Catilina, vehemens et grave: non deest republice consilium, neque auctoritas hujus ordinis: nos, nos, dico aperte, nos consules desumus. Decrevit quonda

NONPAREIL (6 POINTS) No. 8.

Quousque tandem abutere, Catilina, patientia nostra? quamdiu etiam furor iste tuus nos eludet? quem ad finem sese effrenata jactabit audacia? nihilne te nocturnum praesidium palatii, nihil urbis vigiliae, nihil timor populi, nihil concursus bonorum omnium, nihil hic munitissimus habendi senatum locus, nihil horum ora vultusque moverunt? patere tua consilia non sentis? constricta jam horum omnium conscientia tenere conjurationem tuam non vides? quid proxima, quid superiore nocte egeris, ubi fueris quos convocaveris, quid consilii ceperis, quem nostrum ignorari arbitraris? O tempora! O mores! Senatus haec intelligit, consul vidit, hic tamen vivit. Vivit! Immo vero etiam in senatum venit: fit publici consilii particeps; notat et designat oculis et caedem unumquemque nostrum. Nos autem viri fortes, satisfacere reipublicae videmur, si istius furorem actela vitemus. Ad mortem te, Catilina, duci jussu consulis, jam pridem oportebat: in te conferri pestem istam, quam tuus in nos omnes jamdiu machinaris. An vero ver amplissimus, Publius Scipio, pontifex maximus, Tiberium Gracchum, mediocritor labefactantum statum reipublicae, privatus interfecit: Catilinam, orbem terrarum caedem atque incendium vastare cupientem nos consules perferemus? Nam illa nimis antiqua, praeterea quod Caius Servilius Ahala, Spurium Melium, novus rebus studentem manu sua occidit. Fuit, fuit esta quondam in hac republica virtus viri fortes acriter supplicis civem perniciosum, quam acerbissimum hostem coeherent. Habem

A B C D E F G H I J K L M N O P Q R S T U V W X Y Z

ABCDEF GHIJKL MNOPQRST UVWXYZ

1234567890

abcdefghijklmnopqrstuvwxy

1234567890

Quousque tandem abutere, Catilina, patientia nostra? quamdiu etiam furor iste tuus nos eludet? quem ad finem sese effrenata jactabit audacia? nihilne te nocturnum praesidium palatii, nihil urbis vigiliae ni

NONPAREIL (6 POINTS) No. 12.

Quousque tandem abutere, Catilina, patientia nostra? quamdiu etiam furor iste tuus nos eludet? quem ad finem sese effrenata jactabit audacia? nihilne te nocturnum praesidium palatii, nihil urbis vigiliae, nihil timor populi, nihil concursus bonorum omnium, nihil hic munitissimus habendi senatum locus, nihil horum ora vultusque moverunt? patere tua consilia non sentis? constricta jam horum omnium conscientia tenere conjurationem tuam non vides? quid proxima, quid superiore nocte egeris, ubi fueris, quos convocaveris, quid consilii ceperis, quem nostrum ignorare arbitrari? O tempora! O mores! Senatus haec intelligit, consuli videt, hic tamen vivit. Vivit! Immo vero etiam in senatum venit: fit publici concilii particeps; notat et designat oculis ad caedem unumquemque nostrum. Nos autem viri fortes, satisfacere reipublicae videmur, si istius furoriam ac tela vitemus. Ad mortem te, Catilina, duci jussu consulis, jam pridem oportebat; in te conferri pestem istam, quam tu in nos omnes jamdiu machinaris. An vero viri amplissimus, Publius Scipio, pontifex maximus, Tiberium Gracchum, mediocritor labefactantum statum reipublicae, privatus interfecit: Catilinam, orbem terrarum caedem atque incendium vastare cupientem nos consules perferemus? Nam illa nimis antiqua, praeterea, quod Caius Servilius Ahala, Spurium Melium, novus rebus student

A B C D E F G H I J K L M N O P Q R S T U V W X Y Z

ABCDEF GHIJKL MNOPQRST UVWXYZ

1234567890

abcdefghijklmnopqrstuvwxy

1234567890

Quousque tandem abutere, Catilina, patientia nostra? quamdiu etiam furor iste tuus nos eludet? quem ad finem sese effrenata jactabit audacia? nihilne te nocturnum praesidium palatii, nihil ur

NONPAREIL (6 POINTS) No. 14.

Quousque tandem abutere, Catilina, patientia nostra? quamdiu etiam furor iste tuus nos eludet? quem ad finem sese effrenata jactabit audacia? nihilne te nocturnum praesidium palatii, nihil urbis vigiliae, nihil timor populi, nihil concursus bonorum omnium, nihil hic munitissimus habendi senatum locus, nihil horum ora vultusque moverunt? patere tua consilia non sentis? constricta jam horum omnium conscientia tenere conjurationem tuam non vides? quid proxima, quid superiore nocte egeris, ubi fueris, quos convocaveris, quid consilii ceperis, quem nostrum ignorare arbitrari? O tempora! O mores! Senatus haec intelligit, consul videt, hic tamen vivit. Vivit! Immo vero etiam in senatum venit: fit publici consilii particeps; notat et designat oculis ad caedem unumquemque nostrum. Nos autem viri fortes, satisfacere reipublicae videmur, si istius furorem ac tela vitemus. Ad mortem te Catilina duci jussu consulis jam pridem oportebat in te conferri pestem istam, quam tu in nos omnes jamdiu machinaris. An vero viri amplissimus Publius Scipio, pontifex maximus, Tiberium Gracchum, mediocritor labefactantum statum reipublicae, privatus interfecit: Catilinam, orbem terrarum caedem atque incendium vastare cupientem nos consules perferemus? Nam illa nimis antiqua praeterea, quod Caius Servilius Ahala, Spuris

A B C D E F G H I J K L M N O P Q R S T U V W X Y Z

ABCDEF GHIJKL MNOPQRST UVWXYZ

1234567890

abcdefghijklmnopqrstuvwxy

1234567890

Quousque tandem abutere, Catilina, patientia nostra? quamdiu etiam furor iste tuus nos eludet? quem ad finem sese effrenata jactabit audacia? nihilne te nocturnum praesidium palatii, nihil urbis vigiliae, ni

NONPAREIL (6 POINTS) No. 15.

Quousque tandem abutere, Catilina, patientia nostra? quamdiu etiam furor iste tuus nos eludet? quem ad finem sese effrenata jactabit audacia? nihilne te nocturnum praesidium palatii, nihil urbis vigiliae, nihil timor populi, nihil concursus bonorum omnium, nihil hic munitissimus habendi senatum locus, nihil horum ora vultusque moverunt? patere tua consilia non sentis? constricta jam horum omnium conscientia tenere conjurationem tuam non vides? quid proxima, quid superiore nocte egeris, ubi fueris, quos convocaveris, quid consilii ceperis, quem nostrum ignorare arbitrari? O tempora! O mores! Senatus haec intelligit, consul videt, hic tamen vivit. Vivit! Immo vero etiam in senatum venit: fit publici consilii particeps; notat et designat oculis ad caedem unumquemque nostrum. Nos autem viri fortes, satisfacere reipublicae videmur, si istius furorem ac tela vitemus. Ad mortem te, Catilina, duci jussu consulis, jam pridem oportebat: in te conferri pestem istam, quam tu in nos omnes jamdiu machinaris. An vero viri amplissimus, Publius Scipio, pontifex maximus, Tiberium Gracchum, mediocritor labefactantum statum reipublicae, privatus interfecit: Catilinam, orbem terrarum caedem atque incendium vastare cupientem nos consules per

A B C D E F G H I J K L M N O P Q R S T U V W X Y Z

ABCDEF GHIJKL MNOPQRST UVWXYZ

1234567890

abcdefghijklmnopqrstuvwxy

1234567890

Quousque tandem abutere, Catilina, patientia nostra? quamdiu etiam furor iste tuus nos eludet? quem ad finem sese effrenata jactabit audacia? nihilne te nocturnum praesidium palatii nihil ur

MINION (7 POINTS) No. 8.

Quousque tandem abutere, Catilina, patientia nostra? quamdiu etiam furor iste tuus nos eludet? quem ad finem sese effrenata jactabit audacia? nihilne te nocturnum praesidium palatii nihil urbis vigilae, nihil timor populi, nihil concursus bonorum omnium, nihil hic munitissimus habendi senatum locus, nihil orum ora vultusque moverunt? patere tua consilia non senti constrictam jam horum omnium conscientia teneri conjurationem tuam non vides, quid proxima, quid superiore nocte egeris, ubi fueris, quos convocaveris, quid consilii ceperis, quem nostrum ignorare arbitraris. O tempora! O mores! Senatus haec intelligit, consul videt, hec tamen vivet. Vivet! immo vero etiam in senatum venit; fit publicii consilii particeps: notat et designat oculis ad caedem unumquemque nostrum. Nost autem viri fortis, satisfacere reipublicae videmur, si istius furorem ac tela vitemus. Ad mortem te, Catilina, ducii jussu consulis jampridem oportebat: in te conferri pestem istem quam tu in nos omnes jamdiu machinaris

A B C D E F G H I J K L M N O P Q R S T U V W X Y Z

A B C D E F G H I J K L M N O P Q R S T U V W X Y Z

1 2 3 4 5 6 7 8 9 0

abcdefghijklmnopqrstuvwxyz

1 2 3 4 5 6 7 8 9 0

Quousque tandem abutere, Catilina patientia nostra? quamdiu etiam furor isti tuus nos eludet quem ad finem sese effrenata jactabit audacia? nihilne te nocturnum praesidium palatii, nihili

MINION (7 POINTS) No. 12.

Quousque tandem abutere, Catilina, patientia nostra? quamdiu etiam furor iste tuus et nos eludet? quem ad finem sese effrenata jactabit audacia? nihilne te nocturnum praesidium palatii, nihil urbis vigilae, nihil timor populi, nihil concursus bonorum omnium, nihil hic munitissimus habendi senatum locus, nihil horum ora vultusque moverunt? patere tua consilia non sentis? constrictam jam horum omnium conscientia teneri conjurationem tuam non vides? quid proxima, quid superiore nocte egeris, ubi fueris, quos convocaveris, quid consilii ceperis, quem nostrum ignorare arbitraris? O tempora! O mores! Senatus haec intelligit, consul videt, hic tamen vivet. Vivet! immo vero etiam in senatum venit: fit publicii consilii particeps: notat et designat oculis ad caedem unumquemque nostrum. Nos autem viri fortes, satisfacere reipublicae videmur, se istius furoriam ac tela vitemus. Ad mortem te, Catilini, duci jussu consulis, jampridem oportebat: in

A B C D E F G H I J K L M N O P Q R S T U V W X Y Z

A B C D E F G H I J K L M N O P Q R S T U V W X Y Z

1 2 3 4 5 6 7 8 9 0

abcdefghijklmnopqrstuvwxyz

1 2 3 4 5 6 7 8 9 0

Quousque tandem abutere, Catilina, patientia nostra? quamdiu etiam furor iste tuus nos eludet? quem ad finem sese effrenata jactabit audacia? nihilne te nocturnum

MINION (7 POINTS) No. 14.

Quousque tandem abutere, Catilina, patientia nostra? quamdiu etiam furor iste tuus nos eludet? quem ad finem sese effrenata jactabit audacia? nihilne te nocturnum praesidium palatii, nihil urbis vigilae, nihil timor populi, nihil concursus bonorum omnium, nihil hic munitissimus habendi senatum locus, nihil horum ora vultusque moverunt? patere tua consilia non sentis? constrictam jam horum omnium conscientia teneri conjurationem tuam non vides? quid proxima, quid superiore nocte egeris, ubi fueris, quos convocaveris, quid consilii ceperis, quem nostrum ignorare arbitraris? O tempora! O mores! Senatus haec intelligit, consul videt, hic tamen vivet. Vivet! immo vero etiam in senatum venit: fit publicii consilii particeps: notat et designat oculis ad caedem unumquemque nostrum. Nos autem viri fortes satisfacere reipublicae videmur si istius furorem ac tela vitemus. Ad mortem te, Catilina, duce jussu consulis, jampridem oportebat; in te conferri

A B C D E F G H I J K L M N O P Q R S T U V W X Y Z

A B C D E F G H I J K L M N O P Q R S T U V W X Y Z

1 2 3 4 5 6 7 8 9 0

abcdefghijklmnopqrstuvwxyz

1 2 3 4 5 6 7 8 9 0

Quousque tandem abutere, Catilini, patientia nostra? quamdiu etiam furor isti tuus nos eludet quem ad finem sese effrenata jactabit audacia? nihilne te nocturnum praesidium palatii, nihil

MINION (7 POINTS) No. 15.

Quousque tandem abutere, Catilina, patientia nostra? quamdiu etiam furor iste tuus nos eludet? quem ad finem sese effrenata jactabit audacia? nihilne te nocturnum praesidium palatii, nihil urbis vigilae, nihil timor populi, nihil concursus bonorum omnium, nihil hic munitissimus habendi senatum locus, nihil horum ora vultusque moverunt? patere tua consilia non sentis? constrictam jam horum omnium conscientia teneri conjurationem tuam non vides? quid proxima, quid superiore nocte egeris, ubi fueris, quos convocaveris, quid consilii ceperis, quem nostrum ignorare arbitraris? O tempora! O mores! Senatus haec intelligit, consul videt, hic tamen vivet. Vivet! immo vero etiam in senatum venit: fit publicii consilii particeps: notat et designat oculis ad caedem unumquemque nostrum. Nos autem viri fortes, satisfacere reipublicae videmur, si istius furorem ac tela vitemus. Ad mortem te, Catilini

A B C D E F G H I J K L M N O P Q R S T U V W X Y Z

A B C D E F G H I J K L M N O P Q R S T U V W X Y Z

1 2 3 4 5 6 7 8 9 0

abcdefghijklmnopqrstuvwxyz

1 2 3 4 5 6 7 8 9 0

Quousque tandem abutere Catilina patientia nostra? quamdiu etiam furor iste tuus nos eludet? quem ad finem sese effrenata jactabit audacia? nihilne te nocturnum ist

BREVIER (8 POINTS) No. 8.

Quousque tandem abutere, Catilina, patientia nostra? quamdiu etiam furor este tuus nos eludet? quem ad finem sese effrenata jactabit audacia? nihilne te nocturnum praesidium palatii, nihil urbis vigiliae, nihil timor populi, nihil concursus honorum omnium nihil hec munitissimus habendi senatum locus, nihil horum ora vultusque moverunt? paterie tua consilia non sentis? constrictam jam horum omnium conscientia tenerei conjurationem tuam non vides! quid proxima, quid superiore nocte egeris, ubi fuerio quos convocaveris, quid consilii ceperis, quem nostrum ignorare arbitris! O tempora! O mores! Senatus haec intelligit, consul videt, hec tamen vivet. Vivet! immo vero etiam in senatum venit: fit publici consilii particeps; notat et designat oculis ad caedem

ABCDEFGHIJKLMNOPQRSTUVWXYZ

ABCDEFGHIJKLMNOPQRSTUVWXYZ

1234567890

abcdefghijklmnpqrstuvwxy

1234567890

Quousque tandem abutere, Catilina, patientia nostra? quamdiu etiam furor este tuus nos eludet? quem ad finem sese effrenata jactabit audacia? nihilne te nocturnum praesi

BREVIER (8 POINTS) No. 12.

Quousque tandem abutere, Catilina, patientia nostra? quamdiu etiam furor iste tuus nos eludet? quem ad finem sese effrenata jactabit audacia? nihilne te nocturnum praesidium palatii, nihil urbis vigiliae, nihil timor populi, nihil concursus bonorum omnium, nihilne hic munitissimus habendi senatum locus, nihil horum ora vultusque moverunt? paterie tua consilia non sentis? constrictam jam horum omnium conscientia tenere conjurationem tuam non vides? quid proxima, quid superiore nocte egeris, ubi fueris, quos convocaveris, quid consilii ceperis, quem nostrum ignorare arbitris? O tempora! O mores! Senatus haec intelligit, consul videt, hic tamen vivit. Vivit! immo vero etiam in senatum venit: fit publici consilii

ABCDEFGHIJKLMNOPQRSTUVWXYZ

ABCDEFGHIJKLMNOPQRSTUVWXYZ

1234567890

abcdefghijklmnpqrstuvwxy

1234567890

Quousque tandem abutere, Catilina, patientia nostra? quamdiu etiam furor iste tuus nos eludet? quem ad finem sese effrenata jactabit audacia? nihilne te nocturnum praesi

BREVIER (8 POINTS) No. 14.

Quousque tandem abutere, Catilini, patientia nostra? quamdiu etiam furor iste tuus nos eludet? quem ad finem sese effrenata jactabit audacia? nihilne te nocturnum praesidium palatii, nihil urbis vigiliae, nihil timor populi, nihil concursus honorum omnium, nihilne hic munitissimus habendi senatum locus, nihil horum ora vultusque moverunt? paterie tua consilia non sentis? constrictam jam horum omnium conscientia tenerei conjurationem, tuam non vides? quid proxima, quid superiore nocte egeris, ubi fueris, quos convocaveris, quid consilii ceperis, quem nostrum ignorare arbitras? O tempora! O mores! Senatus haec intellegit, consul videt, hic tamen vivit. Vivit! immo vero etiam in senatum venit: fit publici

ABCDEFGHIJKLMNOPQRSTUVWXYZ

ABCDEFGHIJKLMNOPQRSTUVWXYZ

1234567890

abcdefghijklmnpqrstuvwxy

1234567890

Quousque tandem abutere, Catilina, patientia nostra? quamdiu etiam furor iste tuus nos eludet? quem ad finem sese effrenata jactabit audacia? nihilne te nocturnum praesi

BREVIER (8 POINTS) No. 15.

Quousque tandem abutere, Catilina, patientia nostra? quamdiu etiam furor iste tuus nos eludet? quem ad finem sese effrenata jactabit audacia? nihilne te nocturnum praesidium palatii, nihil urbis vigiliae, nihil timor populi, nihil concursus bonorum omnium, nihil hic munitissimus habendi senatum locus nihil horum ora vultusque moverunt? paterie tua consilia non sentis! contro ictam jam horum omnium conscientia tenerei conjurationem tuam non vides quid proxima, quid superiore nocte egeris, ubi fueris, quos convocaveris, qui consilii ceperis, quem nostrum ignorare arbitres? O tempora! O mores! Senatus haec intellegit, consul videt, hic tamen vivit. Vivit! immo vero etiam in

ABCDEFGHIJKLMNOPQRSTUVWXYZ

ABCDEFGHIJKLMNOPQRSTUVWXYZ

1234567890

abcdefghijklmnpqrstuvwxy

1234567890

Quousque tandem abutere, Catilina, patientia nostra? quamdiu etiam furor iste tuus nos eludet? quem ad finem sesei effrenata jactabit audacia? nihilne

BOURGEOIS (9 POINTS) No. 8.

Quousque tandem abutere, Catilina, patientia nostra? quamdiu itiam furor isti tuus nos eludet? quem ad finem sese effrenata jactabit audacia? nihilni te nocturnum præsidium palatii, nihil urbis vigilæ, nihil timor populi, nihil concursus bonorum omnium, nihil hic munitissimus habendi senatum locus, nihil horum ora vultusque moverunt? paterei tua consilia non sentis? constrictam jam horum omnis conscientia teneri conjurationem tuam non vides? quid proxima, quid superiore nocte egeris, ubi fueris, quos convocaveris, quid consilii ceperis, quem nostrum ignorare arbitraris? O tempora! O mores! Senatus hæc intelligit, consul videt, ic

ABCDEFGHIJKLMN OPQRSTUVWXYZ

ABCDEFGHIJKLMN OPQRSTUVWXYZ

1234567890

abcdefghijklmno pqrstuvwxyz

1234567890

Quousque tandem abutere, Catilina, patientia nostra? quamdiu etiam furor iste tuus nos eludet? quem ad finem sese effrenata jactabit audacia? nihilne te noctu

BOURGEOIS (9 POINTS) No. 12.

Quousque tandem abutere, Catilina, patientia nostra? quamdiu etiam furi iste tuus nos eludet? quem ad finem sese effrenata jactabet audacia? nihil te nocturnum, præsidium palatii, nihil urbis vigilæ, nihil timor populii, nihil concursus bonorum omnium, nihil hec munitissimus habendii senatum locus, nihil horum ora vultusque moverunt? patere tua consilia non sentis constrictam jam horum omnium conscientia teneri conjurationem tuam no vides? quid proxima, quid superiore nocte egeris, ubi fueris, quos convoci veris quid concilii ceperis, quem nostrum ignorare arbitraris? O tempora!

ABCDEFGHIJKLMN OPQRSTUVWXYZ

ABCDEFGHIJKLMN OPQRSTUVWXYZ

1234567890

abcdefghijklmno pqrstuvwxyz

1234567890

Quousque tandem abutere, Catilina, patientia nostra? quamdiu etiam furor isti tuus nos eludet? quem ad finem sese effrenata jactabit audacia?

BOURGEOIS (9 POINTS) No. 14.

Quousque tandem abutere, Catilina, patientia nostra? quamdiu etiam furore iste tuus nos eludet? quem ad finem sese effrenata jactabit audacia? nihilne te nocturnum præsidium palatii, nihil urbis vigilæ, nihil timor populii, nihil concursus bonorum omnium, nihil hic munitissimus, habendi senatum locus nihil horum ora vultusque moverunt? patere tua consilia non sentis? consic tam jam horum omnium conscientia tenerii conjurationem tuam non vides? quid proxima, quid superiore nocte egeris, ubi fueris, quos convocaveris, quid consilii ceperis, quem nostrum ignorare arbitraris? O tempora! O mores! Se

ABCDEFGHIJKLMN OPQRSTUVWXYZ

ABCDEFGHIJKLMN OPQRSTUVWXYZ

1234567890

abcdefghijklmno pqrstuvwxyz

1234567890

Quousque tandem abutere, Catilina, patientia nostra? quamdiu etiam furor iste tuus nos eludet? quem ad finem sese effrenata jactabit audacia? nihilne te nocte

BOURGEOIS (9 POINTS) No. 15.

Quousque tandem abutere, Catilina, patientia nostra? quamdiu etiam furor iste tuus nos eludet? quem ad finem sese effrenata jactabit audacia? nihilni te nocturnum, nihil præsidium palatii, nihil urbis vigilæ nihil timor populi, nihil concursus bonorum omnium, nihil hic munitissimus habendi senatum locus, nihilni horum ora vultusque moverunt patere tua consilia non sentis? constrictam jam horum omnium conscientia teneri conjurationem tuam non vides? quid proxima, quid supiore nocte egeris, ubi fueris, quos convocaveris, quid consilii ceperis, et

ABCDEFGHIJKLMN OPQRSTUVWXYZ

ABCDEFGHIJKLMN OPQRSTUVWXYZ

1234567890

abcdefghijklmno pqrstuvwxyz

1234567890

Quousque tandem abutere, Catilina, patientia nostra? quamdiu etiam furor iste tuus nos eludet? quem ad finem sese effrenata jactabit audacia?

LONG PRIMER (10 POINTS) No. 8.

Quousque tandem abutere, Catilina, patientia nostra? quamdiu etiam furi iste tuus nos eludet? quem ad finem sese effrenata jactabit audacia? nihilne te nocturnum praesidium palati, nihil urbes vigilae, nihil timor populi, nihil concursus bonorum omnium, nihil hic munitissimus habendi senatum locus nihil horum ora vultusque moverunt? patere tua consilia non sentis? constrictam jam horum omnium conscientia tenerii conjurationem tuam non vides? quid proxima, quid superiore nocte egeris, ubi fueris, quos convocave

ABCDEF GHIJK LMNOP QRSTUV WXYZ

ABCDEF GHIJK LMNOP QRSTUV WXYZ

1234567890

abcdefghijklmnopqrstuvwxy z

1234567890

Quousque tandem abutere, Catilina, patientia nostra? quamdiu etiam furor iste tuus nos eludet? quem ad finem sese effrenata jactabit audacia? ni

LONG PRIMER (10 POINTS) No. 10.

Quousque tandem abutere, Catilina, patientia nostra? quamdiu etiam furor iste tuus nos eludet? quem ad finem sese effrenata jactabit audacia? nihilne te nocturnum praesidium palatei, nihil urbis vigilae, nihil timor populi, nihil concursus bonorum omnium, nihil hic munitissimus habendi senatum locus, nihil horum ora vultusque moverunt? patre tua consilia non sentis? constrictam jam horum omnium conscientia teneri conjurationem tuam non vides? quid proxima, quid superiore nocte egeris, ubi fueris, et

ABCDEF GHIJK LMNOP QRSTUV WXYZ

ABCDEF GHIJK LMNOP QRSTUV WXYZ

1234567890

abcdefghijklmnopqrstuvwxy z

1234567890

Quousque tandem abutere, Catalina, patientia nostria? quamdiu etiam furor iste tuus nos eludet? quem ad finem sese effrenata jactabit audai

LONG PRIMER (10 POINTS) No. 11.

Quousque tandem abutere, Catilina, patientia nostra? quamdiu etiam furor iste tuus nos eludet? quem ad finem sese effrenata jactabit audacia? nihilne te nocturnum praesidium palatii, nihil urbis vigilae, nihil timor populi, nihil concursus bonorum omnium, nihil hic munitissimus habendi senatum locus, nihil horum ora vultusque moverunt? patere tua consilia non sentis? constrictam jami horum omnium conscientia teneri conjurationem tuam non vides? quid proxima, quid super

ABCDEF GHIJK LMNOP QRSTUV WXYZ

ABCDEF GHIJK LMNOP QRSTUV WXYZ

1234567890

abcdefghijklmnopqrstuvwxy z

1234567890

Quousque tandem abutere, Catilina, patientia nostra? quamdiu etiam furor iste tuus non eludet? quam ad finem sese effrenata jactabit

LONG PRIMER (10 POINTS) No. 14.

Quousque tandem abutere, Catilina, patientia nostra? quamdiu etiam furor iste tuus nos eludet? quem ad finem sese effrenata jactabit audacia? nihilne te nocturnum praesidium palatei, nihil urbis vigilae, nihil timor populi, nihil concursus bonorem omnium, nihil hic munitissimus habendi senatum locus, nihil horum ora vultusque moverunt? patere tua consilia non sentis? constrictam jam horum omnium conscientia teneri conjurationem tuam non vides? quid proxima, quid superis

ABCDEF GHIJK LMNOP QRSTUV WXYZ

ABCDEF GHIJK LMNOP QRSTUV WXYZ

1234567890

abcdefghijklmnopqrstuvwxy z

1234567890

Quousque tandem abutere, Catilina, patientia nostra? quamdiu etiam furor isti tuus nos eludet? quem ad finem sisi effrenata jactabit audacia? ni

SMALL PICA (11 POINTS) No. 11.

Quousque tandem abutere, Catilina, patientia nostra? quamdiu etiam furor iste tuus nos eludet? quem ad finem sese effrenata jactabit audacia? nihilne te nocturnum praesidium palatii, nihil urbis vigilae, nihil timor populi, nihil concursus bonorum omnium, nihil hic munitissimus habendi senatum locus, nihil horum ora vultusque noverunt? patere tua consilia non sentis? constrictam jam horum om

ABCDEFGHIJKLMN**OP**QRSTUVWXYZ

ABCDEFGHIJKLMN**OP**QRSTUVWXYZ

1234567890 abcdefghijklmnopqrstuvwxyz 1234567890

Quousque tandem abutere Catilina patientia nostra? quamdiu etiam furor iste tuus nos eludet? quem ad finem sese effrenata jactabit aud

SMALL PICA (11 POINTS) No. 14.

Quousque tandem abutere, Catilina, patientia nostra? quamdiu etiam furor iste tuus nos eludet? quem ad finem sese effrenata jactabit audacia? nihilne te nocturnum praesidium palatii, nihil urbis vigilae, nihil timor populi, nihil concursus bonorum omnium, nihil hic munitissimus habendi senatum locus, nihil horum ora vultusque moverunt? patere tua consilia non sentis? constrictam jam

ABCDEFGHIJKLMN**OP**QRSTUVWXYZ

ABCDEFGHIJKLMN**OP**QRSTUVWXYZ

1234567890 abcdefghijklmnopqrstuvwxyz 1234567890

Quousque tandem abutere, Catilina, patientia nostra? quamdiu etiam furor iste tuus nos eludet? quem ad finem sese effrenata jactabit audai

PICA (12 POINTS) No. 6.

Quousque tandem abutere, Catilini, patientia nostra? quamdiu etiam furor iste tuus nos eludet? quem ad finem sese effrenata jactabit audacia? nihilne te nocturnum praesidium palatii, nihil urbis vigilae, nihil timor populi, nihil concursus bonorum omnium, nihil hic munitissimus habendi senatum locus, nihil horum ora vultusque

ABCDEFGHIJKLMN**OP**QRSTUVWXYZ

ABCDEFGHIJKLMN**OP**QRSTUVWXYZ

1234567890 abcdefghijklmnopqrstuvwxyz 1234567890

Quousque tandem abutere Catilina patientia nostra? quamdiu etiam furor iste tuus nos eludet? quem ad finem sese ef

PICA (12 POINTS) No. 14.

Quousque tandem abutere, Catilini, patientia nostra? quamdiu etiam furor iste tuus nos eludet? quem ad finem sese effrenata jactabit audacia? nihilne te nocturnum praesidium palatii, nihil urbis vigilae, nihil timor populi, nihil concursus bonorum omnium, nihil hic munitissimus habendi sena

ABCDEFGHIJKLMN**OP**QRSTUVWXYZ

ABCDEFGHIJKLMN**OP**QRSTUVWXYZ

1234567890 abcdefghijklmnopqrstuvwxyz 1234567890

Quousque tandem abutere, Catilina, patientia nostra? quamdiu etiam furor iste tuus nos eludet? quem ad finem sese effrenata

PICA (12 POINTS) No. 8.

Quousque tandem abutere Catilina patientia nostra? quam diu etiam furior este tuus nos eludet? quem ad finem sese effrenata jactabit audacia? nihilne te nocturnum praesidem palatii, nihil urbis vigilae, nihil timor populi, nihil concursi bonorum omnium, nihil hic munitissimus habendi senatum locus, nihil horum ora vultusque moverunt? patere tua consilia non sentis! sconstrictam jam horum omnium conscientia tenerii conjurationem tuami non vidies! quid proximia, quid superiorie nocte egeris, ubi fueris, quos convocaveris,

ABCDEFGHIJKLMNOPQRSTUVWXYZ

ABCDEFGHIJKLMNOPQRSTUVWXYZ

12345 abcdefghijklmnopqrstuvwxyz 67890

ENGLISH (14 POINTS) No. 2.

Quousque tandem abutere, Catilina, patientia nostra? quamdiu etiam furiori istie tuus nos eludet? quem ad finem sese effrenatia jactabit audacia? nihilne te nocturnum praesidium palatii, nihil urbis vigilae, nihil timor populi, nihil concursus bonorum omnium, nihil hic munitissimus habendi senatum locus, nihil horum ora vultusque moverunt? patere tua consilia non sentis? constrictam jam horum omnium conscientia teneri conjurationem tuam non vides? quid proxima, quid superiorie nocte egeris, ubi fueris, quos convocaveris,

ABCDEFGHIJKLMNOPQRSTUVWXYZ

ABCDEFGHIJKLMNOPQRSTUVWXYZ

12345 abcdefghijklmnopqrstuvwxyz 67890

THREE-LINE NONPAREIL (18 POINTS) No. 4.

Quousque tandem abutere, Catilina, patientia nostra? quamdiu etiam furor iste tuus nos eludet? quem ad finem sese effrenata jactabit audacia? nihilne te nocturnum praesidium palatii, nihil urbis vigilae, nihil timor populi, nihil concursus bonorum omnium nihil hic munitissimus habendi senatum locus, nihil horum ora vultusque moverunt? patere tua consilia non sentis? constrictam jam horum omnium conscientia teneri conjurationem tuam non vides? quid proxima, quid superiorie nocte egeris, ubi fueris, quos convocaveris,

ABCDEFGHIJKLMNOPQRSTUVWXYZ

ABCDEFGHIJKLMNOPQRSTUVWXYZ

12345 abcdefghijklmnopqrstuvwxyz 67890

LIGHT-FACE ROMANS.

THREE-LINE NONPAREIL (18 POINTS) ROMAN No. 5. 50 lbs. 38 cts. per lb.

MAGNIFICENT INVENTIONS
American and European Academies of Design
DRAUGHTSMAN AND ENGINEER 68

PARAGON (20 POINTS) ROMAN No. 2. 50 lbs. 38 cts. per lb.

PRINTING MACHINES
Latest Mechanical Improvements
HANDSOME SPECIMENS 9

FIVE-LINE NONPAREIL (30 POINTS) ROMAN No. 3. 50 lbs. 38 cts. per lb.

CONSTRUCTIONS
Celebrated Manufacturers
IRON MINERS, 37

THREE-LINE PICA (36 POINTS) ROMAN No. 3. 50 lbs. 38 cts. per lb.

SUBSCRIBER
Cumberland Ranges.
Mountains 52

FOUR-LINE PICA (48 POINTS) ROMAN No. 3. 50 lbs. 38 cts. per lb.

BORDERS
Prairie Lands 3

HEAVY POSTER ROMANS.

THREE-LINE NONPAREIL (18 POINTS) ROMAN No. 3. 50 lbs. 38 cts. per lb.

EUROPEAN NATIONS
Natives of Foreign Countries, 57

PARAGON (20 POINTS) ROMAN. 50 lbs. 38 cts. per lb.

HANDSOME DESIGNS
Plain and Ornamental Borders, 27

DOUBLE PICA (24 POINTS) ROMAN. 50 lbs. 38 cts. per lb.

DENSE FORESTS
Mexican Fair Grounds 46

THREE-LINE PICA (36 POINTS) ROMAN No. 2. 50 lbs. 38 cts. per lb.

RUDIMENTS
Summer Resort 2

SEVEN-LINE NONPAREIL (42 POINTS) ROMAN. 50 lbs. 38 cts. per lb.

DIRECTOR
Constructions 9

FOUR-LINE PICA (48 POINTS) ROMAN No. 1. 50 lbs. 38 cts. per lb.

THRONE
Continents 3

TITLE NO. 4.

AGATE (5½ POINTS) TITLE NO. 4.
30 A, 60 a. \$2.50

CHEAP ADVERTISING MEDIUM
Advertisements Inserted at Lowest Rates
Daily and Weekly Editions 26

BREVIER (8 POINTS) TITLE NO. 4.
30 A, 60 a. \$3.50

EUROPEAN NOVELTIES
Australian Diamond Merchants
Rubies and Cameos 93

BOURGEOIS (9 POINTS) TITLE NO. 4.
30 A, 60 a. \$3.10

IMPORTED MEDICINES
Manufacturer of Chemicals, 38

THREE-LINE NONP. (18 POINTS) TITLE NO. 4.
10 A, 20 a. \$2.85

PERFORMERS
Minstrel Companies 5

PARAGON (20 POINTS) TITLE NO. 4.
10 A, 20 a. \$4.30

EMPEROR
Manufacturer 8

NONPAREIL (6 POINTS) TITLE NO. 4.
30 A, 60 a. \$2.60

PRINTERS AND ENGRAVERS
Every Description of Book or Job Work
Statements and Circulars, 14

MINION (7 POINTS) TITLE NO. 4.
30 A, 60 a. \$3.00

ELEGANT PRODUCTIONS
Reminiscence of Ancient Europeans
Renowned Journalists 47

LONG PRIMER (10 POINTS) TITLE NO. 4.
30 A, 50 a. \$3.50

THE UNITED STATES
Presidential Candidates 28

PICA (12 POINTS) TITLE NO. 4.
22 A, 32 a. \$3.50

MARION TIMES
Farming Journals, 19

FIVE-LINE NONPAREIL (30 POINTS) TITLE NO. 4.
8 A, 16 a. \$6.00

CHIMES
Governors 2

4 A, 8 a.

THREE-LINE PICA (36 POINTS) TITLE NO. 4.

\$5.20

SECURITIES
National Bankers 65

4 A, 4 a.

FOUR-LINE PICA (48 POINTS) TITLE NO. 4.

\$6.30

HUNTERS
Amusements 13

Quads and Spaces extra.

#0

Cincinnati Type Foundry, 201 Vine St.

TITLE.

AGATE (5½ POINTS) TITLE No. 1.
30 A, 60 a. \$2.50

JOURNAL OF CURRENT EVENTS
Temperance and Social Improvement Society
Many Interesting Notices, 41

BREVIER (8 POINTS) TITLE No. 3.
30 A, 60 a. \$3.50

MITERING MACHINES
Modern Practical Instruments
New Construction, 36

BOURGEOIS (9 POINTS) TITLE No. 2.
30 A, 60 a. \$3.50

THE MIAMI TRIBUNE
Important Democratic Journal
Morning Editions 58

PICA (12 POINTS) TITLE No. 2.
15 A, 30 a. \$3.50

IRON REGION
Mineral Ornaments, 7

PICA (12 POINTS) TITLE No. 1.
15 A, 30 a. \$3.50

FIRE ENGINE
Curving Machine 6

DOUBLE PICA (24 POINTS) TITLE No. 1.
8 A, 16 a. \$4.65

PRINCE
Americans 6

NONPAREIL (6 POINTS) TITLE No. 2.
30 A, 60 a. \$3.50

COMMISSION MERCHANTS
Liberal Advances on Consignments
Select Preserved Fruit 58

MINION (7 POINTS) TITLE No. 2.
30 A, 60 a. \$3.70

WESTERN COUNTRIES
Enchanting Scenes in America
Extensive Prairies 720

LONG PRIMER (10 POINTS) TITLE No. 1.
30 A, 50 a. \$4.30

FOREIGN DESIGNS
Ancient and Modern Ideas
New Specimens 62

SMALL PICA (11 POINTS) TITLE No. 1.
20 A, 30 a. \$2.50

MARKET REPORT
The Farmers Instructor 2

THREE-LINE NONP. (18 POINTS) TITLE No. 1.
10 A, 20 a. \$3.65

COSTUME
Fine Banners 7

PARAGON (20 POINTS) TITLE No. 1.
10 A, 20 a. \$3.90

METEORS
Polar Regions 5

4 A, 8 a.

THREE-LINE PICA (36 POINTS) TITLE No. 1.

\$5.15

NUMEROUS
Pure Brandies 18

4 A, 6 a.

SEVEN-LINE NONPAREIL (42 POINTS) TITLE No. 1.

\$6.00

RESIDENT
Government, 21

Quads and Spaces extra.

21

Cincinnati Type Foundry, 201 Vine St.

ITALIC TITLE.

NONPAREIL (6 POINTS) ITALIC TITLE No. 2.
30 A, 60 a. \$2.60

CHROMATIC JOB PRINTING

Various Colors Printed at one Impression.

Cylinder Distribution \$57

LG. PRIMER (10 POINTS) ITALIC TITLE No. 2.
20 A, 30 a. \$2.45

CHOICEST FRUIT

Extensive Orange Growers.

Tropical Regions 67

PICA (12 POINTS) ITALIC TITLE No. 2.
15 A, 30 a. \$2.80

MANUSCRIPTS

Lessons in Grammar

Instruction 58

BREVIER (8 POINTS) ITALIC TITLE No. 2.
30 A, 60 a. \$3.25

NATIONAL BANKERS

Foreign and Domestic Exchange

Uncurrent Notes, 63

BOURGEOIS (9 POINTS) ITALIC TITLE No. 2.
20 A, 30 a. \$3.25

COUNTY RECORDERS

National Board of Improvements

Auditor's Reports 425

3-LINE NONP. (18 POINTS) ITALIC TITLE No. 2.
10 A, 20 a. \$2.50

COMPANION

Grand Entertainments

Gatherings 75

8 A, 16 a.

PARAGON (20 POINTS) ITALIC TITLE No. 2.

\$3.30

TIMBER REGIONS

Forests of Northern Minnesota, 84

LG. PRIMER (10 POINTS) ITALIC TITLE No. 1.
20 A, 40 a. \$2.90

SIGN PAINTERS

Eminent French Artists.

Italian Sculptors

PICA (12 POINTS) ITALIC TITLE No. 1.
8 A, 18 a. \$2.40

EXCURSION

Atlantic Steamers

Union Line

7 A, 12 a.

FIVE-LINE NONPAREIL (30 POINTS) ITALIC TITLE No. 2.

\$6.00

CONSIGNMENT

Industrious Accountant 15

4 A, 8 a.

THREE-LINE PICA (36 POINTS) ITALIC TITLE No. 2.

\$5.10

SPECIMENS

Chinese Ornaments, 3.

TITLE EXTENDED No. 3.

NONPAREIL (6 POINTS) TITLE EXTENDED No. 3.
35 A, 40 a. \$3.00

EASTERN STATES
Mineral Resources of Maine
River Navigation 63

LONG PRIMER (10 POINTS) TITLE EXTEND. No. 3.
24 A, 24 a. \$3.25

CONTINENTS
Western Boundary
Minnesota 26

BREVIER (8 POINTS) TITLE EXTENDED No. 3.
30 A, 30 a. \$3.00

COMMISSIONER
Consulting Departments
Information, \$45

PICA (12 POINTS) TITLE EXTENDED No. 3.
18 A, 20 a. \$3.40

MONITOR
Patent Machines
Reaper 37

9 A, 14 a. **THREE-LINE NONPAREIL (18 POINTS) TITLE EXTENDED No. 3.** \$3.20

MUSIC TEACHER
Harmonium and Concertina.
Standard Pianos 48

TITLE EXTENDED No. 1.

6 A, 12 a. **PICA (12 POINTS) TITLE EXTENDED No. 1.** \$2.50

FOREIGN COINS
Treasury Departments
Custom House 10

4 A, 8 a. **THREE-LINE NONPAREIL (18 POINTS) TITLE EXTENDED No. 1.** \$3.40

HEIGHTS
Mountain Scene
Landscape 5

4 A, 8 a. **DBL. PICA (24 POINTS) TITLE EXTENDED No. 1.** \$6.00

CREDIT
Trade Items
Grocer 3

EXTRA CONDENSED No. 3.

PICA (12 POINTS) EXTRA CONDENSED No. 3.
16 A, 32 a. \$2.75.

AMERICAN BANKING COMPANY
Savings Institutions for Thriving Citizens 12

ENGLISH (14 POINTS) EXTRA CONDENSED No. 3.
12 A, 24 a. \$2.80.

CYLINDER PRINTING PRESSES
Favorite Machine for Practical Printers 9

THREE-LINE NONP. (18 POINTS) EX. COND. No. 3.
12 A, 24 a. \$3.50.

HOUSEHOLD DECORATIONS
Extensive Array of Fine Furniture 8

PARAGON (20 POINTS) EXTRA CONDENSED No. 3.
10 A, 20 a. \$3.50.

COMBINATION BORDER
Ornaments and Flourishes, \$75

8 A, 16 a.

DBL. PICA (24 POINTS) EXTRA CONDENSED No. 3.

\$4.25

ANNUAL INDUSTRIAL EXPOSITION
Gold and Silver Premiums Awarded Contestants \$87

6 A, 12 a.

FIVE-LINE NONPAREIL (30 POINTS) EXTRA CONDENSED No. 3.

\$5.50

EDUCATIONAL INSTITUTIONS
Harrison and Columbia Female Seminaries 4

5 A, 10 a.

THREE-LINE PICA (36 POINTS) EXTRA CONDENSED No. 3.

\$5.70

ENCHANTING PERSPECTIVE
Cumberland Mountains and Rivulets, 35

4 A, 8 a.

FOUR-LINE PICA (48 POINTS) EXTRA CONDENSED No. 3.

\$6.30

AMERICAN THOUGHT
Standard Scientific Treatise \$9

***CONDENSED No. 4.**

NONPAREIL (6 POINTS) CONDENSED No. 4.
30 A, 60 a. \$2.20

MEETING OF FOREIGN MINISTERS
Narrative of Residences and Travels in China
Some Extraordinary Accounts 847

LONG PRIMER (10 POINTS) CONDENSED No. 4.
18 A, 40 a. \$2.25

MODERN INVENTIONS
County Telephone Connection 86

BREVIER (8 POINTS) CONDENSED No. 4.
30 A, 60 a. \$2.75

HISTORICAL DESCRIPTIONS
Select Reading from Standard Works
Interesting Remarks, 29

PICA (12 POINTS) CONDENSED No. 4.
15 A, 30 a. \$2.25

ELECTION NOTICES
National County Meetings 40

12 A, 24 a.

PARAGON (20 POINTS) CONDENSED No. 4.

\$3.40

DISTINGUISHED PRESIDENTS
Formation of the American Constitution 16

ENGLISH (14 POINTS) CONDENSED No. 4.
15 A, 30 a. \$2.75

HURON TRIBUNE
Devoted to Agriculture 7

THREE-LINE NONPAREIL (18 POINTS) COND. No. 4.
12 A, 24 a. \$3.20

STONE CUTTERS
Granite Monuments, 93

10 A, 16 a.

FIVE-LINE NONPAREIL (30 POINTS) CONDENSED No. 4.

\$4.20

SOUTHERN COUNTRIES
Direct Railroad Communication 75

8 A, 12 a.

THREE-LINE PICA (36 POINTS) CONDENSED No. 4.

\$6.20

SUMMER RESORTS
Pleasant River Excursion, 8

5 A, 8 a.

FOUR-LINE PICA (48 POINTS) CONDENSED No. 4.

\$8.00

MERCHANDISE
Commercial Record 2

TWO-LINE CONDENSED.

<p>NONPAREIL (6 POINTS) CONDENSED No. 5. 36 A. \$1.55 WESTERN MONTHLY REPORTER DEVOTED TO AGRICULTURE. 1250 COPIES.</p> <p>TWO-LINE PEARL (10 POINTS) CONDENSED No. 5. 24 A. \$1.30 GUIDE AND FRIEND GENERAL INFORMATION, 752</p> <p>TWO-LINE NONPAREIL (12 POINTS) COND. No. 5. 24 A. \$2.20 INTERESTING NEWS 1</p>	<p>BREVIER (8 POINTS) CONDENSED No. 5. 24 A. \$1.40 OREGON DAILY OBSERVER BEST ADVERTISING MEDIUM, 3894</p> <p>TWO-LINE AGATE (11 POINTS) CONDENSED No. 5. 24 A. \$1.85 JERSEY MERCURY LARGE CIRCULATION 20</p> <p>TWO-LINE BREVIER (16 POINTS) COND. No. 5. 18 A. \$2.00 FOREIGN NOTICE, 4</p>
<p>16 A. THREE-LINE NONPAREIL (18 POINTS) CONDENSED No. 5. \$2.00 THE LONDON MORNING ENQUIRER, 14</p>	
<p>12 A. TWO-LINE LONG PRIMER (20 POINTS) CONDENSED No. 5. \$2.25 MONROE COUNTY REGISTER 63</p>	
<p>10 A. TWO-LINE ENGLISH (28 POINTS) CONDENSED No. 5. \$3.25 NORTH BEND COURIER 2</p>	
<p>6 A. FOUR-LINE BREVIER (32 POINTS) CONDENSED No. 5. \$2.70 MORRISON SENTINEL 5</p>	
<p>5 A. TWO-LINE PARAGON (40 POINTS) CONDENSED No. 5. \$3.20 BEDFORD RECORD 8</p>	
<p>12 A. TWO-LINE PICA (24 POINTS) CONDENSED No. 1. \$2.35 FREMONT EVENING MONITOR, 8</p>	
<p>6 A. FOUR-LINE BREVIER (32 POINTS) CONDENSED No. 2. \$2.05 SOUTHERN MESSENGER 9</p>	

Quads and Spaces extra.

26

Cincinnati Type Foundry, 201 Vine St.

TWO-LINE LETTER.

<p>TWO-LINE DIAMOND (9 POINTS) No. 5. 20 A. \$1.00 JOURNAL AND MESSENGER 2</p>	<p>TWO-LINE AGATE (11 POINTS) No. 5. 20 A. \$1.20 MILDMINTS GAZETTE 6</p>
<p>TWO-LINE PEARL (10 POINTS) No. 5. 20 A. \$1.20 SOUTH GULCH MINER 4</p>	<p>TWO-LINE NONPAREIL (12 POINTS) No. 5. 20 A. \$1.50 MERRY MOMENTS 8</p>
<p>20 A. TWO-LINE NONPAREIL (12 POINTS) No. 6. \$1.65 FARM NEWS AND STOCK RECORDER 3</p>	
<p>20 A. TWO-LINE MINION (14 POINTS) No. 5. \$2.05 THE WELLINGTON COMMERCIAL 1</p>	
<p>18 A. TWO-LINE BREVIER (16 POINTS) No. 5. \$2.40 MECHANICAL TECHNAGRAPH 35</p>	
<p>15 A. TWO-LINE BREVIER (16 POINTS) No. 9. \$2.40 LEMANDERTON CALIGRAPH 7</p>	
<p>10 A. THREE-LINE NONPAREIL (18 POINTS) No. 5. \$2.20 MANSFIELD REPUBLICAN 9</p>	
<p>10 A. TWO-LINE LONG PRIMER (20 POINTS) No. 5. \$2.10 MONMOUTH LEAFLET 84</p>	
<p>8 A. TWO-LINE PICA (24 POINTS) No. 5. \$2.10 HOMBURG COURIER 35</p>	

TWO-LINE No. 7.

<p>TWO-LINE AGATE (11 POINTS) No. 7. 20 A. \$2.00 WESTERN NEWS 2</p>	<p>TWO-LINE NONPAREIL (12 POINTS) No. 7. 20 A. \$2.00 MENTIS TIMES 5</p>
<p>18 A. TWO-LINE MINION (14 POINTS) No. 7. \$2.50 THE SOUTHERN ENTERPRISE 7</p>	
<p>18 A. TWO-LINE BREVIER (16 POINTS) No. 7. \$2.50 BELINGHAM CHRONICLE 9</p>	

ALDINE.

PEARL ALDINE (NONPAREIL BODY, 6 POINTS.)
30 A, 60 a. \$1.50

RANDOM READINGS CONCERNING PRINTERS

Wilson's Treatise on Punctuation, Complete Printers Manual

Valuable and Instructive Edition, \$2.35

NONPAREIL (6 POINTS) ALDINE.
30 A, 60 a. \$2.00

THEORY OF BRIDGE CONSTRUCTION

Containing Demonstration of the Art and Science

Many Practical Illustrations, 578

Pearl and Nonpareil Aldines line, and can be used as Caps and Small Caps.

ANNUAL SESSION OF THE GRAND LODGE OF FREE AND ACCEPTED MASONS.

BENEVOLENT INSTITUTIONS OF NORTH AMERICA.

THE PROCEEDINGS OF SECRET ORGANIZATIONS.

BREVIER (8 POINTS) ALDINE.
30 A, 60 a. \$2.75

CENTRAL PRINTING WORKS

Publishers of Journals and Magazines

Illustrated Newspaper 94

PICA (12 POINTS) ALDINE.
15 A, 30 a. \$2.60

REVENUE AGENTS

Congressional Committees

Revised Laws 86

LONG PRIMER (10 POINTS) ALDINE.
18 A, 40 a. \$2.25

RICHMOND REPORTER

Commercial and Financial News

Morning Journal 34

THREE-LINE NONPAREIL (18 POINTS) ALDINE.
12 A, 24 a. \$3.35

EXPEDITIONS

History of Greenland

Inhabitant 72

12 A, 24 a.

PARAGON (20 POINTS) ALDINE.

\$4.00

COMBINATION BORDERS

Assortments of Handsome Corners 67

10 A, 16 a.

FIVE-LINE NONPAREIL (30 POINTS) ALDINE.

\$6.40

SECOND EDITION

Grand Selection of Poems 5

8 A, 12 a.

THREE-LINE PICA (36 POINTS) ALDINE.

\$8.20

COMPREHEND

Recent Discoveries 12

Quads and Spaces extra.

28

Cincinnati Type Foundry, 201 Vine St.

LIGHT-FACE EXTENDED.

30 A, 60 a. AGATE LIGHT-FACE EXTENDED. (NONP. BODY, 6 POINTS.) \$3.10

MACHINES FOR PRACTICAL PRINTERS

Our Latest Improved Nonpareil and Reliable Job Printing Machines, \$35
Excellent Presses for Fine Color Printing

30 A, 60 a. NONPAREIL (6 POINTS) LIGHT-FACE EXTENDED. \$3.15

IMPORTANT AMERICAN INDUSTRIES

Agricultural and Mineral Resources of Northwestern Countries
Valuable Farming Districts, \$5080

24 A, 30 a. BREVIER (8 POINTS) LIGHT-FACE EXTENDED. \$3.00

SPECIMENS OF TYPOGRAPHY

Artistic Display of Borders, Rules and Ornaments
Handsome Combinations 365

18 A, 24 a. LONG PRIMER (10 POINTS) LIGHT-FACE EXTENDED. \$2.70

PRACTICAL ENGINEER

Amazon Railroad and Steamboat Company
Pleasant Excursions \$52

12 A, 18 a. PICA (12 POINTS) LIGHT-FACE EXTENDED. \$3.00

HUNTING GROUNDS

German Emigration Societies, \$25
Western Countries

8 A, 12 a. PARAGON (20 POINTS) LIGHT-FACE EXTENDED. \$3.60

PROCEEDING

Original Documents, 16
Amendments

IONIC No. 2.

PEARL IONIC No. 2. (NONP. BODY, 6 POINTS.)
24 A, 48 a. \$2.85

IMMENSE CARPET DEPARTMENT

Extensive Assortment of Foreign Manufactures
Lace Curtains at Reduced Price, 53

LONG PRIMER (10 POINTS) IONIC No. 2.
18 A, 10 a, 36 a. \$3.30

FRENCH LANGUAGE

The Pronunciation of Words
54 DICTIONARIES 43

PICA (12 POINTS) IONIC No. 2.
16 A, 8 a, 32 a. \$3.85

GREAT HEIGHTS

Cumberland Mountains
15 REGIONS 98

NONPAREIL (6 POINTS) IONIC No. 2.
24 A, 12 a, 48 a. \$3.05

LATEST SPECIMEN SHEETS

Estimates for Complete Printing Offices
79 COMPLETE ESTIMATES 58

BREVIER (8 POINTS) IONIC No. 2.
24 A, 12 a, 48 a. \$3.30

FAMOUS GEOMETRICIANS

Wonderful Astronomical Discoveries.
49 TELESCOPES, 888

THREE-LINE NONPAREIL (18 POINTS) IONIC No. 2.
10 A, 6 a, 20 a. \$5.05

REGIMENTS

Mexican Veteran
2 COMMAND 3

10 A, 6 a, 20 a.

PARAGON (20 POINTS) IONIC No. 2.

\$6.90

PATENT MEDICINE

Manufacturers' Convention 4
PROTECTION, \$57

6 A, 4 a, 12 a.

FIVE-LINE NONPAREIL (30 POINTS) IONIC No. 2.

\$7.15

INTRODUCTION

Southern Plantations 16
PRODUCERS 34

4 A, 4 a, 8 a.

FOUR-LINE BREVIER (32 POINTS) IONIC No. 2.

\$8.00

ENCOUNTER

Generous Comrade 7
BRIGADES 2

Quads and Spaces extra.

30

Cincinnati Type Foundry, 201 Vine St.

IONIC No. 2.

6 A, 12 a.

FIVE LINE NONPAREIL (30 POINTS) IONIC No. 3.

\$9.05

COMMONER
Summer Fares 7

5 A, 8 a.

THREE LINE PICA (36 POINTS) IONIC No. 2.

\$10.10

ERMINES
Dominicans 8

4 A, 6 a.

FOUR LINE PICA (48 POINTS) IONIC No. 2.

\$11.25

FENDER
Imitation 5

3 A, 4 a.

FIVE LINE PICA (60 POINTS) IONIC No. 2.

\$14.15

MEND
Barter 4

IONIC.

NONPAREIL (6 POINTS) IONIC.
30 A, 60 a. \$3.00

GRAND OPERA FESTIVAL
Superior Productions of Eminent Men 25

LONG PRIMER (10 POINTS) IONIC.
20 A, 38 a. \$2.25

NONPAREIL PRESS
Improved Printing Machine, 4

ENGLISH (14 POINTS) IONIC.
15 A, 20 a. \$2.60

SETTLEMENTS
Pioneer Association 1

PARAGON (20 POINTS) IONIC.
10 A, 16 a. \$3.75

BANQUET
Grand Dinner, 8

BREVIER (8 POINTS) IONIC.
30 A, 60 a. \$2.70

STEAMSHIP COMPANIES
San Francisco and African Route 32

PICA (12 POINTS) IONIC.
20 A, 38 a. \$3.20

IMPORTATIONS
Linen and Embroiderie, 9

THREE-LINE NONPAREIL (18 POINTS) IONIC.
10 A, 16 a. \$3.00

PURCHASER
Credit Accounts, 6

DBL. PICA (24 POINTS) IONIC.
10 A, 12 a. \$5.00

GROUND
Continnence 3

6 A, 8 a.

THREE-LINE PICA (36 POINTS) IONIC.

\$6.00

DOCUMENTS
Retired Merchant 7

6 A, 8 a.

SEVEN-LINE NONPAREIL (42 POINTS) IONIC.

\$10.00

BOUNTIES
Auction Sales 2

4 A, 6 a.

FOUR-LINE PICA (48 POINTS) IONIC.

\$8.85

CHOKER
Statement 1

Quads and Spaces extra.

32

Cincinnati Type Foundry, #01 Vine St.

DORICS.

PEARL DORIC. (NONP. BODY, 6 POINTS.)
30 A, 60 a. \$2.80

PERMANENT ORGANIZATIONS
London Marine Insurance Company 75

BREVIER (8 POINTS) DORIC.
35 A, 38 a. \$2.95

COUNTY AUDITOR
First Annual Statement 2

PICA (12 POINTS) DORIC.
18 A, 20 a. \$3.00

MERRIMENT
Choicest Presents 5

FIVE-LINE NONPAREIL (30 POINTS) DORIC.
6 A, 10 a. \$5.75

CHIDE
Fortune 7

NONPAREIL (6 POINTS) DORIC.
30 A, 50 a. \$2.75

FINE PORCELAIN CARDS
Extensive Assortments of Paper, 187

LONG PRIMER (10 POINTS) DORIC.
20 A, 30 a. \$3.40

FRENCH PRINT
Artistic Combination 7

TWO-LINE BREVIER (16 POINTS) DORIC.
12 A, 12 a. \$3.50

SCHEMES
India Nation 6

PARAGON (20 POINTS) DORIC.
10 A, 12 a. \$4.50

THORNS
Conscience 8

6 A, 10 a.

THREE-LINE PICA (36 POINTS) DORIC.

\$7.00

RECEPTION
Border Scenes 24

4 A, 6 a.

SEVEN-LINE NONPAREIL (42 POINTS) DORIC.

\$9.00

SUPERIOR
Commanders 3

4 A, 6 a.

FOUR-LINE PICA (48 POINTS) DORIC

\$9.75

HOUNDS
Cucumber 2

FRENCH ANTIQUE.

NONPAREIL (6 POINTS) FRENCH ANTIQUE.
30 A, 60 a. \$2.60

LITHOGRAPHING STONES

Favorite Shade where the Girls Promenade
Delightful City Parks 82

LONG PRIMER (10 POINTS) FRENCH ANTIQUE.
20 A, 38 a. \$2.50

IMPORTED POTTERIES

Bohemian Enameled Glassware.
Large Assortments 93

THREE-LINE NONP. (18 POINTS) FRENCH ANTIQUE.
10 A, 16 a. \$2.75

PERFORMER

Great Comedians 26

FIVE-LINE NONP. (30 POINTS) FRENCH ANTIQUE.
6 A, 8 a. \$4.60

GROCER

Cinnamon 3

BREVIER (8 POINTS) FRENCH ANTIQUE.
30 A, 60 a. \$2.70

HANDSOME LITHOGRAPHS

Landscapes, Portraits, and Diplomas
Elegant Oil Paintings, 86

PICA (12 POINTS) FRENCH ANTIQUE.
20 A, 38 a. \$3.25

CHOICE EDITION

Department of Literature
Public Libraries 75

PARAGON (20 POINTS) FRENCH ANTIQUE.
10 A, 16 a. \$3.00

SELECTION

Random Notes 4

THREE-LINE PICA (36 POINTS) FRENCH ANTIQUE.
4 A, 6 a. \$5.60

MEND

Honour 5

4 A, 5 a.

SEVEN-LINE NONPAREIL (42 POINTS) FRENCH ANTIQUE.

\$8.20

FOUNDER

Corner Stone 13

3 A, 4 a.

FOUR-LINE PICA (48 POINTS) FRENCH ANTIQUE.

\$8.25

THRONE

Monuments 2

Quads and Spaces extra.

34

Cincinnati Type Foundry, 201 Vine St.

ANTIQUE No. 6.

NONPAREIL (6 POINTS) ANTIQUE No. 5.
30 A, 60 a. \$1.90

FINE THERMOMETERS AND MICROSCOPES

Costly Mathematical and Astronomical Instruments 135

NONPAREIL (6 POINTS) ANTIQUE No. 6.
30 A, 60 a. \$2.25

SELECT BIOGRAPHICAL SKETCHES

Reproductions from Distinguished Men, 50

BREVIER (8 POINTS) ANTIQUE No. 6.
30 A, 60 a. \$2.90

PUBLISHING COMPANIES

Merchants Advertising Directory, 125

THREE-LINE NONP. (18 POINTS) ANTIQUE No. 6.
15 A, 24 a. \$3.50

COMPROMISE

Farmer and Dealer 8

NONPAREIL (6 POINTS) ANTIQUE No. 4.
30 A, 60 a. \$1.90

JEFFERSON'S INAUGURAL ADDRESS

Famous Senators and Congressmen of America 48

MINION (7 POINTS) ANTIQUE No. 6.
30 A, 60 a. \$2.75

IMPROVED PASSENGER COACHES

Atlantic and Great Western Railroads, 630

LONG PRIMER (10 POINTS) ANTIQUE No. 6.
24 A, 50 a. \$2.60

FEMALE SEMINARIES

Our Educational Institutions, 25

PICA (12 POINTS) ANTIQUE No. 6.
20 A, 38 a. \$3.20

ESTABLISHMENTS

Many Accommodations, 135

10 A, 16 a.

DBL. PICA (24 POINTS) ANTIQUE No. 6.

\$5.00

PRINTERS EMPORIUM

Plain and Ornamented Letter 34

7 A, 12 a.

THREE-LINE PICA (36 POINTS) ANTIQUE No. 6.

\$6.70

INDUCEMENTS

Prominent Members 27

6 A, 10 a.

SEVEN-LINE NONPAREIL (42 POINTS) ANTIQUE No. 6.

\$8.00

EXCURSION

Boston Steamers 3

5 A, 8 a.

FOUR-LINE PICA (48 POINTS) ANTIQUE No. 6.

\$8.75

Dark RED Ink 1

Quads and Spaces extra.

35

Cincinnati Type Foundry, 201 Vine St.

SKELETON ANTIQUE No. 2.

BREVIER (8 POINTS) SKELETON ANTIQUE No. 2.
36 A, 70 a. \$2.25

PROF. HARPERS STATISTICAL GAZETTEER

Description of United States, Canada and New Brunswick

Containing Numerous Colored Maps, 415

THREE-LINE NONP. (18 POINTS) SKEL. ANT. No. 2.
15 A, 30 a. \$2.75

ERIE TRUST COMPANY

Permanent Banking Organizations

Enormous Dividends, 15

PARAGON (20 POINTS) SKELETON ANTIQUE No. 2.
15 A, 30 a. \$4.00

IMPORTED GUITARS

Select Musical Instruments

Tambourines, 92

LONG PRIMER (10 POINTS) SKELETON ANT. No. 2.
30 A, 60 a. \$3.00

MARION AGRICULTURAL SOCIETY

Provisions for the Improvement of Public Lands

Ohio Foresters Convention 490

PICA (12 POINTS) SKELETON ANTIQUE No. 2.
20 A, 40 a. \$2.00

JAPANESE ART POTTERIES

German Porcelain and Enameled Wares

Ceramic Researches. 1883.

FIVE-LINE NONP. (30 POINTS) SKEL. ANT. No. 2.
12 A, 24 a. \$4.30

LITHOGRAPHING

Steam Printing House

Art Journal 37

8 A, 16 a.

SEVEN-LINE NONPAREIL (42 POINTS) SKELETON ANTIQUE No. 2.

\$5.50

ENTHUSIASTIC MEETINGS

Proceedings of Decennial Boards 68

6 A, 12 a.

FOUR-LINE PICA (48 POINTS) SKELETON ANTIQUE No. 2.

\$5.75

EUROPEAN COUNTRIES

French and German Government 2

ANTIQUE CONDENSED No. 2.

NONPAREIL (6 POINTS) ANTIQUE COND. No. 2.
30 A, 60 a. \$2.15

STATE TREASURY DEPARTMENT
Financial Conditions of our National Government
Annual Receipts and Expenses 927

LONG PRIMER (10 POINTS) ANTIQUE COND. No. 2.
24 A, 50 a. \$2.95

SOUTHERN COUNTRIES
Emancipation Proclamations, \$24

3-LINE NONPAREIL (18 POINTS) ANT. COND. No. 2.
15 A, 24 a. \$3.50

GOVERNMENTS
Mexican Revolutions 5

BREVIER (8 POINTS) ANTIQUE CONDENSED No. 2.
30 A, 60 a. \$2.70

CULTIVATION OF FLOWERS
North American Journal of Horticulture
Select Garden Plants 360

PICA (12 POINTS) ANTIQUE CONDENSED No. 2.
20 A, 48 a. \$3.00

MONARCH ENGINES
Printing Machine Works, 75

PARAGON (20 POINTS) ANTIQUE CONDENSED No. 2.
18 A, 24 a. \$4.80

PROMENADE
Summer Resorts 6

12 A, 18 a. FIVE-LINE NONPAREIL (30 POINTS) ANTIQUE CONDENSED No. 2. \$5.65

MINUTE DESCRIPTION
Ancient and Modern Writers 25

8 A, 11 a. THREE-LINE PICA (36 POINTS) ANTIQUE CONDENSED No. 2. \$5.75

CHARMING CHORUS
Dramatic Entertainment 13

5 A, 8 a. SEVEN-LINE NONPAREIL (42 POINTS) ANTIQUE CONDENSED No. 2. \$7.00

SUPREME COURT
Condemned Prisoner, 8

5 A, 8 a. FOUR-LINE PICA (48 POINTS) ANTIQUE CONDENSED No. 2. \$7.75

Huron GOLD Mine 1

ANTIQUE CONDENSED.

BREVIER (8 POINTS) ANTIQUE CONDENSED No. 4.
30 A, 60 a. \$2.20

DEALERS IN TROPICAL FRUITS

Bananas, Oranges, Lemons and Coconuts

Imported French Wines, 157

PICA (12 POINTS) ANTIQUE CONDENSED No. 4.
20 A, 28 a. \$2.50

GOVERNMENT OFFICERS

National Treasury Department

Revenue Laws, \$10

LONG PRIMER (10 POINTS) ANTIQUE COND. No. 4.
24 A, 50 a. \$2.35

ENGLISH OPERA TROUPE

Performance of Prominent Actors

Splendid Scenery 829

ENGLISH (14 POINTS) ANTIQUE CONDENSED No. 4.
18 A, 36 a. \$2.70

SCHOOL OF DESIGN

Regular Morning Exercises

Learned Student 80

15 A, 24 a. THREE-LINE NONPAREIL (18 POINTS) ANTIQUE CONDENSED No. 4. \$3.30

EASTERN MANUFACTURING CITIES

Superintendent of National Industrial Expositions

New Business Transactions, 279

12 A, 18 a. PARAGON (20 POINTS) ANTIQUE CONDENSED No. 4. \$3.00

EMPIRE STEAMSHIP AGENCY

American Marine Insurance Company 13

10 A, 16 a. FIVE-LINE NONPAREIL (30 POINTS) ANTIQUE CONDENSED No. 4. \$5.00

EDITORS DEPARTMENT

Numerous Recommendations 786

9 A. FOUR-LINE BREVIER (32 POINTS) ANTIQUE CONDENSED No. 1. \$3.60

CLOTHING MERCHANTS 25

4 A, 4 a. FOUR-LINE PICA (48 POINTS) ANTIQUE CONDENSED. \$5.70

Grand ERIE Route

LATIN ANTIQUE.

NONPAREIL (6 POINTS) LATIN ANTIQUE.
24 A, 50 a. \$2.70

MERCHANTS' EXCHANGES

Foreign and Domestic Productions
Grain Speculations, 124

PICA (12 POINTS) LATIN ANTIQUE.
15 A, 30 a. \$2.95

DESCRIPTIONS

Celebrated Statesmen
Guardians, \$30

THREE-LINE NONP. (18 POINTS) LATIN ANTIQUE.
12 A, 18 a. \$3.75

ENCOMIUM

Garden Flowers
Pansies, 54

BREVIER (8 POINTS) LATIN ANTIQUE.
24 A, 50 a. \$2.95

WESTERN COMPANIES

Extensive Iron Manufactories
Mantel and Grate, 35

LONG PRIMER (10 POINTS) LATIN ANTIQUE.
18 A, 36 a. \$2.95

ENTERTAINMENT

Numerous Presentations
Amusements, 47

PARAGON (20 POINTS) LATIN ANTIQUE.
8 A, 13 a. \$4.70

HEROISM

Commander
Post, 6

8 A, 12 a.

DBL. PICA (24 POINTS) LATIN ANTIQUE.

\$6.15

INDUCEMENTS

Union Convention, 8

5 A, 8 a.

THREE-LINE PICA (36 POINTS) LATIN ANTIQUE.

\$7.85

NEIGHBORS

Condemnation 73

4 A, 5 a.

FOUR-LINE PICA (48 POINTS) LATIN ANTIQUE.

\$10.00

MODERN

Remanents 5

Quads and Spaces extra.

39

Cincinnati Type Foundry, 201 Vine St.

LIGHT RUNIC.

18 A, 36 a. LONG PRIMER (10 POINTS) LIGHT RUNIC. \$2.00

PRINTING AND LITHOGRAPHING ESTABLISHMENTS

Valuable Collection of Beautiful Specimens of Printing and Lithographing, 57
Beautiful Wood and Steel Engravings

20 A, 40 a. PICA (12 POINTS) LIGHT RUNIC. \$2.60

LATEST SPECIMENS OF PRINTING MATERIAL

Our Extensive Collection of Select Flourishes and Ornaments, \$92
Combination Borders and Rules

14 A, 20 a. THREE-LINE NONPAREIL (18 POINTS) LIGHT RUNIC. \$2.60

EUROPEAN FASHION EMPORIUMS

Originators of Handsome Styles and Fashions, 187
Fine Embroideries and Laces

12 A, 18 a. DOUBLE PICA (24 POINTS) LIGHT RUNIC. \$3.55

ENTERPRISING CONCERNS

Cincinnati Manufacturers' Convention 6
Merchants and Traders

10 A, 16 a. FIVE-LINE NONPAREIL (30 POINTS) LIGHT RUNIC. \$5.15

FORTUNE HUNTER

Fremont Pioneer Association 4

8 A, 12 a. THREE-LINE PICA (36 POINTS) LIGHT RUNIC. \$6.25

CORNER STONE

Extensive Foundation 5

LIGHT RUNIC.

5 A, 8 a.

SEVEN-LINE NONPAREIL (42 POINTS) LIGHT RUNIC.

\$6.85

INDENTURES
Government Land 8
Commenced

5 A, 8 a.

FOUR-LINE PICA (48 POINTS) LIGHT RUNIC.

\$8.35

RETICENCE
Coarse 25 Linens
Ambrosia

4 A, 6 a.

FIVE-LINE PICA (60 POINTS) LIGHT RUNIC.

\$9.35

HEIRDOM
Enchantment 1
Grammar

MODERN ANTIQUE.

NONPAREIL (6 POINTS) MODERN ANTIQUE.
30 A, 60 a. \$2.50

NORTHERN LUMBER MERCHANT
Extensive Pine Forest of Northern Michigan
Building Materials, 548

PICA (12 POINTS) MODERN ANTIQUE.
20 A, 40 a. \$3.00

MODERN PRINTING
Numerous Improvements 1
Par Excellence

BREVIER (8 POINTS) MODERN ANTIQUE.
30 A, 60 a. \$3.00

INSTRUMENT MANUFACTURER
Composers of Fascinating Overtures
Euphonium Solo, 26

LONG PRIMER (10 POINTS) MODERN ANTIQUE.
24 A, 50 a. \$3.00

ORNAMENTAL CARVING
Prize Compositions by Harmes.
School of Design 84

10 A, 16 a.

FIVE-LINE NONPAREIL (30 POINTS) MODERN ANTIQUE.

\$6.40

SECOND REUNION
Lake Huron Excursions 39

THREE-LINE NONP. (18 POINTS) MODERN ANT.
16 A, 24 a. \$3.90

MEMORANDUM
Domestic Productions
Handsome 21

DOUBLE PICA (24 POINTS) MODERN ANTIQUE.
12 A, 20 a. \$4.50

COMBINED
Natural History
Museum \$5

8 A, 12 a.

THREE-LINE PICA (36 POINTS) MODERN ANTIQUE.

\$8.50

EMBROIDERIES
Commission Brokers 6

6 A, 10 a.

SEVEN-LINE NONPAREIL (42 POINTS) MODERN ANTIQUE.

\$8.90

CONDUCTORS
Summer Resort 25

MODERN ANTIQUE.

5 A, 8 a.

FOUR-LINE PICA (48 POINTS) MODERN ANTIQUE.

\$10.90

MEETINGS
Administration
Senator 6

4 A, 5 a.

FIVE-LINE PICA (60 POINTS) MODERN ANTIQUE.

\$10.25

RESORT
Amusement
Dance 5

3 A, 4 a.

SIX-LINE PICA (72 POINTS) MODERN ANTIQUE.

\$11.20

MINER
Diamond 1

MODERN ANTIQUE CONDENSED.

Lg. PRIMER (10 POINTS) MODERN ANTIQUE COND.
24 A, 48 a. \$3.25

SUMMER RAMBLE IN SOUTHERN LANDS
Through New-Built Villages of Joyous Homes 5

DBL. PICA (24 POINTS) MODERN ANTIQUE COND.
12 A, 24 a. \$4.20

ELEGANT DESIGNS
Commercial Reporter 21

FIVE-LINE NONP. (30 POINTS) MOD. ANT. COND.
8 A, 16 a. \$5.50

MACHINISTS
Standard Engine 8

PICA (12 POINTS) MODERN ANTIQUE CONDENSED.
18 A, 36 a. \$2.75

DECLARATION OF INDEPENDENCE
Thrilling Events of the Revolution 1776

3-LINE NONP. (18 POINTS) MODERN ANT. COND.
18 A, 36 a. \$4.00

WESTERN HUNTING CLUB
Eleventh Annual Reunion 1884

THREE-LINE PICA (36 POINTS) MOD. ANT. COND.
6 A, 12 a. \$5.00

ROMANCER
Grand Chorus 6

5 A, 10 a. FOUR-LINE PICA (48 POINTS) MODERN ANTIQUE CONDENSED. \$6.25

AMERICAN PRODUCE
Household Decorations \$30

4 A, 8 a. FIVE-LINE PICA (60 POINTS) MODERN ANTIQUE CONDENSED. \$9.00

FOREIGN COURT
Prominent Merchant 4

4 A, 8 a. SIX-LINE PICA (72 POINTS) MODERN ANTIQUE CONDENSED. \$10.75

Rural HOME Scene

Quads and Spaces extra.

44

Cincinnati Type Foundry, 201 Vine St.

MODERN ANTIQUE WIDE.

20 A, 30 a. PICA (12 POINTS) MODERN ANTIQUE WIDE. \$3.65

DISTINGUISHED NEIGHBORS
North American Fire Insurance Company
Annual Conventions 128

10 A, 16 a. THREE-LINE NONPAREIL (18 POINTS) MODERN ANTIQUE WIDE. \$3.75

HUNTINGTON HEIGHTS
Pleasant Steamboat Excursions.
Generous Donation 34

10 A, 16 a. PARAGON (20 POINTS) MODERN ANTIQUE WIDE. \$4.85

SELECTED DESIGNS
Handsomest Adornments 7

6 A, 8 a. FIVE-LINE NONPAREIL (30 POINTS) MODERN ANTIQUE WIDE. \$5.60

SKETCHINGS
Ground Cinnamon 3

4 A, 6 a. THREE-LINE PICA (36 POINTS) MODERN ANTIQUE WIDE. \$7.00

THUNDER
German Count 1

3 A, 4 a. FOUR-LINE PICA (48 POINTS) MODERN ANTIQUE WIDE. \$8.90

BUNCH
Comment, 6

ANTIQUÉ EXTENDED No. 3.

35 A.	PEARL ANTIQUE EXTENDED No. 3. (NONPAREIL BODY, 6 POINTS.)	\$2.40
	DEVELOPMENT OF MODERN IDEAS SUPERIOR PRODUCTIONS OF CELEBRATED INVENTORS, 6357	
35 A.	NONPAREIL (6 POINTS) ANTIQUE EXTENDED No. 3.	\$2.40
	ILLUSTRATED CATALOGUES ORIENTAL FURNITURE MANUFACTORY 46	
25 A.	BREVIER (8 POINTS) ANTIQUE EXTENDED No. 3.	\$2.50
	GENERAL AGENCIES MARINE INSURANCE COMPANY 4	
24 A.	LONG PRIMER (10 POINTS) ANTIQUE EXTENDED No. 3.	\$2.60
	MONTHLY PAYMENT UNITED STATES CURRENCY 73	
15 A.	PICA (12 POINTS) ANTIQUE EXTENDED No. 3.	\$2.40
	COMMISSIONER PREMIUM DOCUMENT 16	
10 A.	TWO-LINE BREVIER (16 POINTS) ANTIQUE EXTENDED No. 3.	\$2.25
	RESIDENCES COUNTRY HOMES 7	
10 A.	TWO-LINE LONG PRIMER (20 POINTS) ANTIQUE EXTENDED No. 3.	\$3.00
	COURT HOUSE 5	
6 A.	TWO-LINE PICA (24 POINTS) ANTIQUE EXTENDED No. 3.	\$3.00
	MORNINGS 2	
5 A.	FIVE-LINE NONPAREIL (30 POINTS) ANTIQUE EXTENDED No. 3.	\$4.00
	PRINTER 8	

ANTIQUE EXTENDED No. 4.

NONPAREIL (6 POINTS) ANTIQUE EXTEND. No. 4.
22 A, 32 a. \$2.90

EASTERN STEAMER
American Productions 2
Bronze Mantels

BREVIER (8 POINTS) ANTIQUE EXTENDED No. 4.
16 A, 28 a. \$3.00

INDEPENDENT
Editorial Leaders 3
Inducements

8 A, 12 a. TWO-LINE BREVIER (16 POINTS) ANTIQUE EXTENDED No. 4. \$3.85

MODERN TYPE
Brass Rule Borders 6
Useful Machine

Lg. PRIM. (10 POINTS) ANTIQUE EXTEND. No. 4.
14 A, 20 a. \$3.05

TELEGRAM
Grand Forest 4
Musicians

PICA (12 POINTS) ANTIQUE EXTENDED No. 4.
12 A, 18 a. \$3.75

RESUME
Bank Note 5
Current

6 A, 10 a. PARAGON (20 POINTS) ANTIQUE EXTENDED No. 4. \$4.00

MEDICINES
Domestic Fruits 7

5 A, 6 a. FIVE-LINE NONPAREIL (30 POINTS) ANTIQUE EXTENDED No. 4. \$5.00

CHIMES
Gold Coins 8

3 A, 6 a. SEVEN-LINE NONPAREIL (42 POINTS) ANTIQUE EXTENDED No. 4. \$9.25

MIND
Round 9

ANTIQUE EXTENDED No. 1.

AGATE ANTIQUE EXTEND. No. 1. (NONP. BODY.)
(6 POINTS.) 40 A. \$3.40

GENERAL AGENCY
ACME MACHINE OFFICE
BRIDGE WORK 21

NONPAREIL (6 POINTS) ANTIQUE EXTEND. No. 1.
15 A, 30 a. \$3.00

CONTRACTOR
American Merchant
Canadian 78

BREVIER (8 POINTS) ANTIQUE EXTENDED No. 1.
15 A, 30 a. \$3.25

DRUMMER
Barren Court 86

LG. PRIMER (10 POINTS) ANT. EXTEND. No. 1.
12 A, 18 a. \$3.35

NUMBER
Governor 10

10 A, 12 a.

PICA (12 POINTS) ANTIQUE EXTENDED No. 1.

\$3.70

MOUNT HOPE
Present Generation 4

4 A, 8 a.

THREE-LINE NONPAREIL (18 POINTS) ANTIQUE EXTENDED No. 1.

\$4.50

HERMIT
Round Dome 7

4 A, 4 a.

DBL. PICA (24 POINTS) ANTIQUE EXTENDED No. 1.

\$5.75

MINER
Diamond 1

CLARENDON EXTENDED.

LONG PRIMER (10 POINTS) CLARENDON EXTEND.
10 A, 16 a. \$3.20

GROGER
Products 37

PICA (12 POINTS) CLARENDON EXTENDED.
8 A, 12 a. \$3.50

BENCH
Custom, 8

6 A, 8 a.

PARAGON (20 POINTS) CLARENDON EXTENDED.

\$4.00

THUNDER
Amendment, 45

6 A, 8 a.

FIVE-LINE NONPAREIL (30 POINTS) CLARENDON EXTENDED.

\$8.75

HERDS
Romancer 1

FRENCH CLARENDON EXTENDED.

PEARL FRENCH CLAREN. EXTEND. (NONP. BODY.)
(6 POINTS.) 30 A, 42 a. \$2.65

COMPLETE OFFICE OUTFIT

Printers Cabinets, Stands and Cases
Marble Imposing Stone 47

NONPAREIL (6 POINTS) FR. CLAREN. EXTEND.
30 A, 42 a. \$3.15

REVENUE COLLECTOR

Commissioner for New Mexico.
Pension Agencies 637

Pearl and Nonpareil French Clarendon Extended line, and can be used as Caps and Small Caps.

BREVIER (8 POINTS) FR. CLAREN. EXTENDED.
20 A, 36 a. \$3.00

COMBINATIONS

Ornamental Brass Rules.
Metal Corners 17

LONG PRIMER (10 POINTS) FR. CLAREN. EXTEND.
22 A, 32 a. \$3.45

TELEPHONES

Distant Connections
Electrician 52

PICA (12 POINTS) FR. CLARENDON EXTENDED.
16 A, 20 a. \$3.60

MORNING
Ornaments 83

3-LINE NONP. (18 POINTS) FR. CLAR. EXTEND.
12 A, 14 a. \$5.00

EMPIRE
Steamers 26

7 A, 10 a.

PARAGON (20 POINTS) FRENCH CLARENDON EXTENDED.

\$5.00

RESOURCES

American Mines 8

5 A, 7 a.

DBL. PICA (24 POINTS) FRENCH CLARENDON EXTENDED.

\$5.20

DISTRICTS

Roman Home 5

4 A, 6 a.

FIVE-LINE NONPAREIL (30 POINTS) FRENCH CLARENDON EXTENDED.

\$7.15

TIERCE

Dimension 7

3 A, 4 a.

THREE-LINE PICA (36 POINTS) FRENCH CLARENDON EXTENDED.

\$8.70

HIDES

Demand 1

Quads and Spaces extra.

49

Cincinnati Type Foundry, 201 Vine St.

FRENCH CLARENDON.

NONPAREIL (6 POINTS) FRENCH CLARENDON.
30 A, 60 a. \$2.00

THE AMERICAN SCIENTIFIC ASSOCIATION
Latest Publications including Reprints and Original Works
Biographies of Distinguished Writers, 640

LONG PRIMER (10 POINTS) FRENCH CLARENDON.
30 A, 50 a. \$2.50

STEEL-PLATE ENGRAVING
Handsome Specimens and Designs
Attractive Collection 62

THREE-LINE NONPAREIL (18 POINTS) FR. CLAR.
18 A, 24 a. \$3.00

PICTURE FRAMES
Bronzed Mantel Ornaments
Fine Chandeliers 80

BREVIER (8 POINTS) FRENCH CLARENDON.
30 A, 60 a. \$2.50

CELEBRATED MATHEMATICIAN
Manufacture of Astronomical Instruments
Transits, Compasses, Levels, 84

PICA (12 POINTS) FRENCH CLARENDON.
20 A, 30 a. \$2.75

LAKE SHORE LINE
Direct Railroad Connection
Passenger Depot 37

DBL. PICA (24 POINTS) FRENCH CLARENDON.
12 A, 18 a. \$4.40

ANCESTORS
Present Generation.
Conference 90

10 A, 16 a. FIVE-LINE NONPAREIL (30 POINTS) FRENCH CLARENDON. \$5.25

NUMEROUS DEPOSITS
Sun Fire Insurance Company 273

8 A, 12 a. THREE-LINE PICA (36 POINTS) FRENCH CLARENDON. \$6.40

COMMISSIONER
Northern Merchant 25

6 A, 8 a. FOUR-LINE PICA (48 POINTS) FRENCH CLARENDON. \$9.00

INSTRUCTOR
Printers Manual 4

EGYPTIAN EXTRA CONDENSED.

PICA (12 POINTS) EGYPTIAN EXTRA CONDENSED.
15 A, 24 a. \$2.50

FRENCH AND GERMAN WRITERS
Memoirs of Renowned European Mechanics 47

THREE-LINE NONPAREIL (18 POINTS) EGYPTIAN
EX. COND. 15 A, 24 a. \$2.00

STANDARD PRINTING MACHINES
Nonpareil and Reliable Printing Presses 13

3-LINE PICA (36 POINTS) EGYPTIAN EX. COND.
8 A, 12 a. \$3.40

RECOMMENDATIONS
Commencement Exercises 15

DBL. PICA (24 POINTS) EGYPTIAN EX. COND.
12 A, 18 a. \$2.00

VALUABLE IMPROVEMENTS
National Board of Transportation 37

8 A, 12 a. SEVEN-LINE NONPAREIL (42 POINTS) EGYPTIAN EXTRA CONDENSED. \$4.00

SOUTHERN COTTON MERCHANT
Manufacturers and Traders Conventions 587

6 A, 8 a. FOUR-LINE PICA (48 POINTS) EGYPTIAN EXTRA CONDENSED. \$5.25

FURNITURE COMPANIES
Excellent Domestic Productions 64

5 A, 8 a. FIVE-LINE PICA (60 POINTS) EGYPTIAN EXTRA CONDENSED. \$7.25

INSURANCE AGENT
Monumental Association 2

4 A, 6 a. SIX-LINE PICA (72 POINTS) EGYPTIAN EXTRA CONDENSED. \$8.00

Third NATIONAL Bank

GOTHIC No. 3.

NONPAREIL (6 POINTS) GOTHIC No. 3.
40 A, 60 a. \$2.25

FASHIONABLE CLOTHING EMPORIUMS
Extensive Assortments of Gents' Furnishing Goods 25c
French and German Importations

LONG PRIMER (10 POINTS) GOTHIC No. 3.
20 A, 40 a. \$2.00

GERMAN SAVINGS BANKS
Safe Investment and Liberal Returns 4
Government Securities

BREVIER (8 POINTS) GOTHIC No. 3.
30 A, 50 a. \$2.00

CHOICE MUSICAL SELECTIONS
Instrumental and Vocal Interpretations 364
Wagner Festival at Bayreuth

PICA (12 POINTS) GOTHIC No. 3.
20 A, 30 a. \$2.35

MINERAL PRODUCTS
Exhibited at Denver Exposition 7
Choicest Specimens

14 A, 24 a. THREE-LINE NONPAREIL (18 POINTS) GOTHIC No. 3. \$3.60

ROAMING THE MOUNTAINS
Summer Excursions to Northern Resorts 68
Inspiring Scenes of Grandeur

10 A, 14 a. DBL. PICA (24 POINTS) GOTHIC No. 3. \$5.00

HAMBURG MUSEUM
Selection Natural Wonders 6

ANTIQUE No. 3.

10 A, 12 a. THREE-LINE NONPAREIL (18 POINTS) ANTIQUE No. 3. \$2.60

HOUSE FURNISHING GOODS
Latest Designs in Interior Decorations 24

8 A, 10 a. PARAGON (20 POINTS) ANTIQUE No. 3. \$2.75

MORNING IN SUMMER
Gathering Daisies in the Meadow 3

8 A, 10 a. DBL. PICA (24 POINTS) ANTIQUE No. 3. \$3.40

BOSTON COMMONS
Historical Recollections of '76

GOTHIC No. 11.

BREVIER (8 POINTS) GOTHIC No. 11.
30 A. \$1.75

SECURE INVESTMENT
MANUFACTURERS' BANK, 78

TWO-LINE BREVIER (16 POINTS) GOTHIC No. 11.
18 A. \$2.35

PRESIDENTS
GOVERNMENT, 8

THREE-LINE NONP. (18 POINTS) GOTHIC No. 11.
16 A. \$2.95

DESIGNER, 12

LONG PRIMER (10 POINTS) GOTHIC No. 11.
24 A. \$1.75

SELECT EDITIONS
MODERN WRITINGS, 82

PICA (12 POINTS) GOTHIC No. 11.
20 A. \$1.85

DOCUMENTS
COURT HOUSES 53

PARAGON (20 POINTS) GOTHIC No. 11.
10 A. \$3.00

REGIONS, 3

8 A.

FIVE-LINE NONPAREIL (30 POINTS) GOTHIC No. 11.

\$3.65

CHOICE BRAIDS 2

GOTHIC No. 10.

BREVIER (8 POINTS) GOTHIC No. 10.
20 A, 20 A. \$3.00

FOREIGN MINISTERS
AMERICAN GOVERNMENT 42

TWO-LINE BREVIER (16 POINTS) GOTHIC No. 10.
12 A, 12 A. \$3.75

MOUNTAINS
COMMANDER, 64

THREE-LINE NONP. (18 POINTS) GOTHIC No. 10.
10 A, 10 A. \$4.00

RICHMOND 5

LONG PRIMER (10 POINTS) GOTHIC No. 10.
18 A, 18 A. \$3.25

RICH COSTUMES
FRESCO PAINTERS 142

PICA (12 POINTS) GOTHIC No. 10.
15 A, 15 A. \$3.50

COMPANIONS
FINE RESIDENCE 41

PARAGON (20 POINTS) GOTHIC No. 10.
8 A, 8 A. \$4.25

HUNTERS 1

5 A, 5 A.

FIVE-LINE NONPAREIL (30 POINTS) GOTHIC No. 10.

\$4.75

HOME RECORD 5

TELESCOPIC GOTHICS.

NONP. (6 POINTS) TELESCOPIC GOTHIC No. 5.
60 A. \$1.60

THE GREAT WESTERN STEAM PRINTING COMPANY.
HENDERSON, BROWN & KNIGHT, LITHOGRAPHERS AND ENGRAVERS
NO. 54 MADISON ST., DETROIT, MICHIGAN

NONP. (6 POINTS) TELESCOPIC GOTHIC No. 6.
60 A. \$1.90

OUR EXTENSIVE PRINTING MACHINE WORKS
MANUFACTURER OF PLATEN AND CYLINDER PRESSES
CINCINNATI TYPE FOUNDRY, 201 VINE ST.

NONP. (6 POINTS) TELESCOPIC GOTHIC No. 7.
60 A. \$2.45

BORDERS, FLOURISHES, CORNERS
ESTIMATES AND SPECIMENS FURNISHED.
NEW CARD ORNAMENTS, 375

NONP. (6 POINTS) TELESCOPIC GOTHIC No. 8.
60 A. \$2.45

INTERESTING PERIODICAL
HARPER'S SCIENTIFIC AMERICAN
MONTHLY JOURNAL, 24

Nonpareil Telescopic Gothics line, and can be used as Caps and Small Caps.

GOTHIC No. 9.

NONPAREIL (6 POINTS) GOTHIC No. 9.
30 A, 30 A, 60 a. \$3.30

IMMENSE EASTERN CORPORATIONS
North American Fire Insurance Companies 12
HOME PROTECTION GUARANTEED, 42

BREVIER (8 POINTS) GOTHIC No. 9.
30 A, 30 A, 60 a. \$3.80

EXTENSIVE OCCUPATIONS
Productive Regions of Pennsylvania, 89
ENORMOUS COAL MINES, 20

20 A, 20 A, 30 a. LONG PRIMER (10 POINTS) GOTHIC No. 9. \$3.00

HUNTER'S CELEBRATED MINSTREL TROUPE
Unequaled Organization of Renowned American Comedians, 532
MADISON SQUARE THEATRE, MARCH 25TH.

15 A, 15 A, 20 a. PICA (12 POINTS) GOTHIC No. 9. \$3.25

MEETING OF PROMINENT EDITORS
Second Annual Democratic Editorial Convention, 76
GREAT POLITICAL DISCUSSIONS, 854

12 A, 12 A, 20 a. THREE-LINE NONPAREIL (18 POINTS) GOTHIC No. 9. \$4.00

EUROPEAN PRODUCTIONS
Monument of Grecian Architecture 27
GRANITE AND MARBLE, \$563

Quads and Spaces extra.

34

Cincinnati Type Foundry, 201 Vine St.

GOTHIC No. 9.

8 A, 8 A, 12 a.

PARAGON (20 POINTS) GOTHIC No. 9.

\$5.25

PRINTERS' EMPORIUM
Manufacturers Departments, 79
ORIGINAL DESIGNS, 60

6 A, 6 A, 8 a.

FIVE-LINE NONPAREIL (30 POINTS) GOTHIC No. 9.

\$6.50

CONSTRUCTION
American Inventions 13
GOVERNMENTS 84

4 A, 4 A, 6 a.

THREE-LINE PICA (36 POINTS) GOTHIC No. 9.

\$3.00

MESSENGER
Roman General 2
ENGINEER 34

4 A, 4 A, 6 a.

SEVEN-LINE NONPAREIL (42 POINTS) GOTHIC No. 9.

\$10.00

SERMONS
Ceremonies, 5
MEMBERS 29

GOTHIC No. 2.

PEARL GOTHIC No. 2. (NONP. BODY, 6 POINTS.)
30 A, 60 a. \$2.25

CYLINDER PRINTING MACHINERY
Latest Improved Nonpareil Printing Press.
Patent Receding Bed, \$225

NONPAREIL (6 POINTS) GOTHIC No. 2.
30 A, 60 a. \$2.75

HANDSOME ENGRAVINGS
Attractive and Valuable Premiums
Choice Selection, \$3.90

Pearl and Nonpareil Gothic No. 2 line, and can be used as Caps and Small Caps.

SELECT EDITIONS FOR MECHANICS AND ENGINEERS
PERSONAL HISTORY AND EXPERIENCE OF DISTINGUISHED AMERICANS
PRACTICAL GUIDE BOOK, 3795 PAGES.

BREVIER (8 POINTS) GOTHIC No. 2.
30 A, 60 a. \$2.80

OPERA COMPANIES
Dramatical Entertainment.
Admission, \$1.25

PICA (12 POINTS) GOTHIC No. 2.
15 A, 20 a. \$2.75

MONUMENTS
Granite and Marble.
Cemetery 52

LONG PRIMER (10 POINTS) GOTHIC No. 2.
20 A, 30 a. \$2.95

HUDSON TRIBUNE
Farmers Home Journal
\$2 per Annum

TWO-LINE BREVIER (16 POINTS) GOTHIC No. 2.
15 A, 20 a. \$3.00

MERCHANT
American Grocer
Produce 16

8 A, 12 a.

PARAGON (20 POINTS) GOTHIC No. 2.

\$3.25

MOUNTAIN REGIONS
Mineral and Timber Sections
Finest Material 84

8 A, 12 a.

DBL. PICA (24 POINTS) GOTHIC No. 2.

\$4.30

DIRECT ROUTE
Eastern Railroads 273

Quads and Spaces extra.

56

Cincinnati Type Foundry, 201 Vine St.

GOTHIC No. 2.

6 A, 8 a.

FIVE-LINE NONPAREIL (30 POINTS) GOTHIC No. 2.

\$5.60

MONUMENTS
European Countries
Commerce 6

5 A, 8 a.

THREE-LINE PICA (36 POINTS) GOTHIC No. 2.

\$7.50

DESIGNER
North American
Homes 25

4 A, 6 a.

SEVEN-LINE NONPAREIL (42 POINTS) GOTHIC No. 2.

\$8.00

THRONES
Ancient Ruins
German 8

4 A, 6 a.

FOUR-LINE PICA (48 POINTS) GOTHIC No. 2.

\$10.50

HEROES
Command 5

GOTHIC No. 12.

PEARL GOTHIC No. 12. (NONP. BODY, 6 POINTS.)
30 A. \$1.30

REGULAR MORNING EXERCISES
THE CINCINNATI GYMNASIUM BUILDING
SELECT EXHIBITIONS, 547

NONPAREIL (6 POINTS) GOTHIC No. 12.
30 A. \$1.60

DOMINION GOVERNMENT
UNITED COLONIES OF AMERICA
UNKNOWN REGION 28

Pearl and Nonpareil Gothics line, and can be used as Caps and Small Caps.

BREVIER (8 POINTS) GOTHIC No. 12.
30 A. \$1.95

FOREIGN KINGDOMS
CHINESE IMMIGRATION 16

LONG PRIMER (10 POINTS) GOTHIC No. 12.
30 A. \$2.00

REFRESHMENTS
CHOICE BOURBON 53

PICA (12 POINTS) GOTHIC No. 12.
20 A. \$2.10

JURISDICTION
COURT HOUSE 90

TWO-LINE BREVIER (16 POINTS) GOTHIC No. 12.
15 A. \$2.40

BURNISHER
ADORNMENT 14

12 A. THREE-LINE NONPAREIL (18 POINTS) GOTHIC No. 12. \$2.25

REVENUE COMMISSIONER, 25

8 A. PARAGON (20 POINTS) GOTHIC No. 12. \$2.40

MODERN RESIDENCES 79

8 A. TWO-LINE PICA (24 POINTS) GOTHIC No. 12. \$2.95

SENIOR MEMBERS, 84

6 A. FIVE-LINE NONPAREIL (30 POINTS) GOTHIC No. 12. \$3.00

FOREIGN SHORE 12

5 A. THREE-LINE PICA (36 POINTS) GOTHIC No. 12. \$3.90

CONFERENCE, 8

4 A. SEVEN-LINE NONPAREIL (42 POINTS) GOTHIC No. 12. \$4.20

DESIGNERS 5

OOTIC SERIES.

(PATENTED.)

NONPAREIL (6 POINTS) OTCIC.
30 A. \$1.50

GORGEOUS SPRING DOORS
MOROOOO BOUND BOOKS, \$8236

LONG PRIMER (10 POINTS) OTCIC.
20 A. \$1.45

CURIOUS ROSES
CROCUS SHRUBS. 890

BREVIER (8 POINTS) OTCIC.
30 A. \$2.00

ROSSBURG OOURIER
SUSPENSION BRIDGES 26

PICA (12 POINTS) OTCIC.
20 A. \$2.00

SOUR DROPS
DRUM CORPS, 60

15 A. TWO-LINE BREVIER (16 POINTS) OTCIC. \$2.00

CORRUPT SCHOOL BOARD, \$36

8 A. TWO-LINE LONG PRIMER (20 POINTS) OTCIC. \$2.30

SUPERIOR RECORDS, 36

8 A. TWO-LINE PICA (24 POINTS) OTCIC. \$3.00

GOOD BOURBON, 90

6 A. FIVE-LINE NONPAREIL (30 POINTS) OTCIC. \$3.00

ROUGH SONGS 63

5 A. THREE-LINE PICA (36 POINTS) OTCIC. \$4.40

PRODUCERS 8

4 A. SEVEN-LINE NONPAREIL (42 POINTS) OTCIC. \$4.40

GROUNDNS 2

4 A. FOUR-LINE PICA (48 POINTS) OTCIC. \$6.35

BORDER 5

GOTHIC EXTRA CONDENSED No. 2.

PICA (12 POINTS) GOTHIC EXTRA COND. NO. 2.
36 A, 52 a. \$3.00

DISCOVERIES IN THE FOURTEENTH CENTURY

Historical and Descriptive Accounts of American Continent

Early Settlements of the Huguenots, 1527

5-LINE NONP. (30 POINTS) GOTH. EX. COND. NO. 2.
14 A, 20 a. \$5.50

MITERING MACHINES

New Universal Rule Shaper

Various Cutters 94

3-LINE NONP. (18 POINTS) GOTH. EX. COND. NO. 2.
24 A, 42 a. \$4.50

EMANCIPATION PROCLAMATION

Declaration of American Independence,

Distinguished Presidents 260

DBL. PICA (24 POINTS) GOTHIC EX. COND. NO. 2.
18 A, 32 a. \$6.20

IMPORTANT MEETINGS

Continental Building Association,

Business Transactions 85

14 A, 20 a. FOUR-LINE BREVIER (32 POINTS) GOTHIC EXTRA CONDENSED NO. 2. \$6.50

SPECIMENS OF PRECIOUS STONES

Extensive Diamond Regions of Southern Australia

Famous Manufacturing Jewelers 34

8 A, 14 a. THREE-LINE PICA (36 POINTS) GOTHIC EXTRA CONDENSED NO. 2. \$5.40

STANDARD GERMAN DICTIONARY

Dresden Mercantile Library Association 56

7 A, 10 a. SEVEN-LINE NONPAREIL (42 POINTS) GOTHIC EXTRA CONDENSED NO. 2. \$7.25

GOVERNMENT CONTRACTOR

Eastern Commission Merchants 27

GOTHIC CONDENSED No. 5.

NONPAREIL (6 POINTS) GOTHIC COND. No. 5.
35 A, 70 a. \$2.50

VALUABLE INFORMATION FOR PRINTERS
Luminous and Prominent Colors and Delicate Tints.
Specimens of Neat Combinations 820

LONG PRIMER (10 POINTS) GOTHIC COND. No. 5.
30 A, 50 a. \$2.75

COUNTRY CYLINDER PRESS
Modern Mechanical Improvements.
Excellent Distribution 386

ENGLISH (14 POINTS) GOTHIC CONDENSED No. 5.
20 A, 38 a. \$2.75

RAILROAD COMPANY
New Rules and Regulations
Alarm Punches, \$35

BREVIER (8 POINTS) GOTHIC CONDENSED No. 5.
30 A, 60 a. \$2.75

AMERICAN PATENT AGENCIES
Protection of Citizens of the United States
Manuals for Inventors, \$439

PICA (12 POINTS) GOTHIC CONDENSED No. 5.
20 A, 38 a. \$2.75

CELEBRATED RESORTS
Romantic Seashore Excursion.
Summer Vacations 34

3-LINE NONP. (18 POINTS) GOTHIC COND. No. 5.
18 A, 24 a. \$3.60

CONTEMPORARIES
Carriage Manufacturer
Fine Barouches 5

18 A, 24 a.

PARAGON (20 POINTS) GOTHIC CONDENSED No. 5.

\$4.15

GREAT EUROPEAN EMPIRES
Manners and Customs of Foreign Nations.
Orations and Discourses 74

14 A, 18 a.

FIVE-LINE NONPAREIL (30 POINTS) GOTHIC COND. No. 5.

\$5.00

GOVERNMENT BUILDINGS
Eastern National Universities 29

6 A, 10 a.

THREE-LINE PICA (36 POINTS) GOTHIC CONDENSED No. 5.

\$4.30

FOREIGN STEAMERS
South American Commerce 1

GOTHIC CONDENSED.

LONG PRIMER (10 POINTS) GOTHIC COND. No. 6.
30 A, 50 a. \$2.70

EASTERN SPORTING FRATERNITY
Grand American Pedestrian Tournaments 4

PICA (12 POINTS) GOTHIC CONDENSED No. 6.
24 A, 36 a. \$2.95

UNITED MASONIC SOCIETIES
Co-operative Benefit Associations 92

18 A, 24 a. THREE-LINE NONPAREIL (18 POINTS) GOTHIC CONDENSED No. 6. \$3.15

STANDARD NORTHWESTERN TRANSPORTATION LINES
The Portsmouth, Cincinnati and Kanawha Packet Companies, \$845

12 A, 20 a. DBL. PICA (24 POINTS) GOTHIC CONDENSED No. 6. \$4.05

EASTERN SEWING MACHINE MANUFACTURERS
Undoubted References and Testimonials Furnished \$632

48 A. LONG PRIMER (10 POINTS) GOTHIC CONDENSED No. 1. \$1.95

JOURNAL OF GENERAL INFORMATION FOR ART PRINTERS AND TYPOGRAPHERS

40 A. PICA (12 POINTS) GOTHIC CONDENSED No. 1. \$2.00

ENTERPRISING ESTABLISHMENTS PREFER NONPAREIL PRESSES

30 A. THREE-LINE NONPAREIL (18 POINTS) GOTHIC CONDENSED No. 1. \$3.00

INTERNATIONAL GRAPHIC ARTS EXCHANGE

24 A. TWO-LINE LONG PRIMER (20 POINTS) GOTHIC CONDENSED No. 1. \$3.00

SUPERIOR MOULDING PICTURE FRAMES

12 A. TWO-LINE PICA (24 POINTS) GOTHIC CONDENSED No. 1. \$2.25

OFFICERS OF STATE TREASURY

8 A. THREE-LINE PICA (36 POINTS) GOTHIC CONDENSED No. 1. \$3.45

REDUCED PRICE LIST.

4 A. FOUR-LINE PICA (48 POINTS) GRECIAN. \$3.00

SOUTHERN FRUITS

GOTHIC CONDENSED No. 3.

PICA (12 POINTS) GOTHIC CONDENSED No. 3.
15 A, 50 a. \$1.80

CENTENNIAL EXPOSITIONS
North American Manufactures, 5

3-LINE NONP. (18 POINTS) GOTHIC COND. No. 3.
18 A, 36 a. \$2.40

FRESCO PAINTINGS
Handsome Adornments 3

DBL. PICA (24 POINTS) GOTHIC CONDENSED No. 3.
12 A, 24 a. \$3.85

ENCAMPMENT
Advance Guards 6

PARAGON (20 POINTS) GOTHIC CONDENSED No. 3.
12 A, 24 a. \$2.55

CONGREGATIONS
Promenade Concert 8

10 A, 16 a. THREE-LINE PICA (36 POINTS) GOTHIC CONDENSED No. 3. \$4.80

MIDNIGHT GATHERERS
Ancient Masonic Societies 32

8 A, 12 a. SEVEN-LINE NONPAREIL (42 POINTS) GOTHIC CONDENSED No. 3. \$5.65

EASTERN HEMISPHERE
Astronomical Observation 17

6 A, 10 a. FOUR-LINE PICA (48 POINTS) GOTHIC CONDENSED No. 3. \$6.75

SUPERIOR COURT
Unanimous Decisions 4

6 A. FIVE-LINE PICA (60 POINTS) GOTHIC EXTRA CONDENSED. \$5.00

FOREIGN BRANDIES 25

GOTHIC CONDENSED NO. 7.

PEARL GOTHIC CONDENSED NO. 7. (NONP. BODY.)
(6 POINTS.) 60 A. \$1.65

UNIQUE ORIGINAL CUNEIFORM MANUSCRIPT
CONTEMPORANEOUS AUTOBIOGRAPHICAL ENCYCLOPEDIAS \$74

BREVIER (8 POINTS) GOTHIC CONDENSED NO. 7.
48 A. \$1.80

EXCELLENCE AND DURABILITY COMBINED, 248

PICA (12 POINTS) GOTHIC CONDENSED NO. 7.
35 A. \$2.05

RURAL INSURANCE COMPANY, 9

NONPAREIL (6 POINTS) GOTHIC CONDENSED NO. 7.
60 A. \$1.65

ORCHESTRAL ACCOMPANIMENTS
SELECT PROGRAMME OF MODERN COMPOSITIONS, \$49

LONG PRIMER (10 POINTS) GOTHIC COND. NO. 7.
40 A. \$1.80

ORIGINAL KENSINGTON NEEDLEWORK 73

TWO-LINE MINION (14 POINTS) GOTH. COND. NO. 7.
24 A. \$1.85

STEAMBOAT TRANSFERS, 7

16 A. THREE-LINE NONPAREIL (18 POINTS) GOTHIC CONDENSED NO. 7. \$1.80

UNEXCEPTIONAL PHOTOGRAPHIC PORTRAITURE \$9

12 A. TWO-LINE LONG PRIMER (20 POINTS) GOTHIC CONDENSED NO. 7. \$1.80

EUROPEAN EXPERIMENTING CONVENTION 6

12 A. TWO-LINE PICA (24 POINTS) GOTHIC CONDENSED NO. 7. \$2.25

RELIABLE PRINTING MACHINERY \$23

8 A. TWO-LINE ENGLISH (28 POINTS) GOTHIC CONDENSED NO. 7. \$2.30

UNPRECEDENTED REDUCTIONS, 5

8 A. FIVE-LINE NONPAREIL (30 POINTS) GOTHIC CONDENSED NO. 7. \$2.85

COMMISSION MERCHANTS, 8

6 A. THREE-LINE PICA (36 POINTS) GOTHIC CONDENSED NO. 7. \$3.10

CHOICE EMBROIDERIES 4

5 A. FOUR-LINE PICA (48 POINTS) GOTHIC CONDENSED NO. 7. \$3.90

MODERN MANSION 2

Actual Lining of Complete Series Gothic Condensed No. 7.

H
H
H
H
H
H
H
H
H
H
H
H
H
H
H
H
H
H
H
H
H
H
H
H
H
H

GOTHIC CONDENSED No. 4.

18 A, 24 a. LONG PRIMER (10 POINTS) GOTHIC CONDENSED No. 4. \$3.00

HANDSOME HOUSEHOLD FURNISHING GOODS

Convenience and Necessity Faithfully Studied and Combined with Elegance
Prices in Accordance with Grade of Material 42

20 A, 38 a. PICA (12 POINTS) GOTHIC CONDENSED No. 4. \$3.00

NEW SERIES OF TYPOGRAPHIC CHARMS

Each Line and Curve Embodiments of Graceful Symmetry 65

18 A, 24 a. THREE-LINE NONPAREIL (18 POINTS) GOTHIC CONDENSED No. 4. \$3.00

THE CINCINNATI TYPE FOUNDRY

Latest Improved Nonpareil Printing Machinery 47

GOTHIC ITALIC No. 1.

35 A, 50 a. BREVIER (8 POINTS) GOTHIC ITALIC No. 1. \$2.60

NORTHERN INCORPORATIONS DEVELOPING RESOURCES

*Home Petroleum and Mining Company Supplies Mineral Products to the Trades
Stocks and Bonds on the Pennsylvania Market, \$25*

35 A, 46 a. LONG PRIMER (10 POINTS) GOTHIC ITALIC No. 1. \$2.90

HISTORICAL AND GEOGRAPHICAL SOCIETIES

*Incidents of Adventure in Khordistan and Equatorial Regions of Arabia
Great Natural Gas Reservoirs in Ohio 24*

22 A, 32 a. PICA (12 POINTS) GOTHIC ITALIC No. 1. \$3.00

NEW TYPOGRAPHIC DECORATIONS

Lectures on Harmonious Combinations and Contrasts, \$39

18 A, 25 a. TWO-LINE BREVIER (16 POINTS) GOTHIC ITALIC No. 1. \$3.50

COMPLETE NEWSPAPER OUTFITS

Combinations of Beauty and Gracefulness, \$268

14 A, 20 a. PARAGON (20 POINTS) GOTHIC ITALIC No. 1. \$4.10

PATENT SEWING MACHINE

Numerous Mechanical Attachments, \$45

GOthic ITALIC.

PEARL GOTHIC ITALIC NO. 2. (NONP. BODY.)
(6 POINTS.) 30 A, 60 a. \$2.00

NUMEROUS BEAUTIFUL SEASHORE RESIDENCES

Personal Narrative and Results of Travels Through Scotland.

Boundless River and Mountain Scenes, 790

NONPAREIL (6 POINTS) GOTHIC ITALIC NO. 3.
30 A, 60 a. \$2.40

AMERICAN CENTENNIAL EXPOSITION

Finest Agricultural and Industrial Implements.

Distribution of Premiums, \$3670

NONPAREIL (6 POINTS) GOTHIC ITALIC NO. 2.
30 A, 60 a. \$2.00

INSTRUCTIVE MAGAZINES AND JOURNALS

Authentic Biographies of Eminent European Writers

Useful and Entertaining Knowledge, 632

BREVIER (8 POINTS) GOTHIC ITALIC NO. 3.
30 A, 52 a. \$2.00

CELEBRATED ENGLISH HISTORIANS

Berlin Historical and Poetical Associations

Moral and Political Philosophy 19

36 A, 52 a.

BREVIER (8 POINTS) GOTHIC ITALIC NO. 2.

\$2.60

WONDERFUL RESULTS ACHIEVED BY MODERN PRINTING MACHINERY

Illustrated with Choice Selections from the work of the Photo-Engraver, Autotypographer, etc.

Limited Edition de Lux for Subscribers only, \$97

30 A, 42 a.

LONG PRIMER (10 POINTS) GOTHIC ITALIC NO. 2.

\$2.60

UNPRECEDENTED SUCCESS OF REPUBLICAN PRINCIPLES

The Right of the American Citizen to decide what Laws shall govern his own State

Reaching from the Arctic Sea to the Equator 42

22 A, 38 a.

PICA (12 POINTS) GOTHIC ITALIC NO. 2.

\$2.50

JUVENILE INSTRUCTION RENDERED INTERESTING

Working Models of Machinery for Schools Supplied with Promptness 37

18 A, 25 a.

THREE-LINE NONPAREIL (18 POINTS) GOTHIC ITALIC NO. 2.

\$2.80

THE CORRECT OFFICIAL PROGRAMME

Trains Direct from the City to the Grounds and Return 12

18 A, 24 a.

PARAGON (20 POINTS) GOTHIC ITALIC NO. 2.

\$3.65

MODERN TYPOGRAPHIC DESIGNS

Beautiful Card Ornaments and Flourishes \$59

10 A, 14 a.

FIVE-LINE NONPAREIL (30 POINTS) GOTHIC ITALIC NO. 2.

\$4.50

RENOWNED PRESIDENTS

Prominent American Statesmen 16

LIGHT CELTIC.

NONPAREIL (6 POINTS) LIGHT CELTIC.
36 A, 70 a. \$3.00
TYPE FOUNDRY COMPANY
Estimates and Specimen Sheets 82

LONG PRIMER (10 POINTS) LIGHT CELTIC.
25 A, 42 a. \$3.25
ADMINISTRATION
Numerous Appointments 5

BREVIER (8 POINTS) LIGHT CELTIC.
36 A, 52 a. \$3.25
STEAMBOAT BUILDING
Lake and River Purposes 148

PICA (12 POINTS) LIGHT CELTIC.
25 A, 32 a. \$3.40
CORPORATIONS
Annual Expenditure, 6

14 A, 20 a. THREE-LINE NONPAREIL (18 POINTS) LIGHT CELTIC. \$3.60

NORTHERN FORESTS
Minnesota Pioneer Associations, 39

10 A, 14 a. PARAGON (20 POINTS) LIGHT CELTIC. \$4.10

TROPICAL REGION
Florida Orange Groves 48

4 A, 6 a. FIVE-LINE NONPAREIL (30 POINTS) LIGHT CELTIC. \$4.35

PRESIDENTS
Cabinet Positions 12

4 A, 6 a. THREE-LINE PICA (36 POINTS) LIGHT CELTIC. \$7.30

REMORSE
Concealment, 2

3 A, 4 a. FOUR-LINE PICA (48 POINTS) LIGHT CELTIC. \$8.75

HONEST
Mechanic 3

CELTIC No. 3.

NONPAREIL (6 POINTS) CELTIC No. 3.
35 A, 30 A, 40 a. \$3.90

LATEST IMPROVED MACHINES

Cincinnati Nonpareil and Reliable Jobbers

NEW BORDERS AND ORNAMENTS 65

BREVIER (8 POINTS) CELTIC No. 3.
20 A, 20 A, 40 a. \$3.85

HOME PRODUCTS

American Iron Merchant

MINING REGIONS 5

MINION (7 POINTS) CELTIC No. 3.
20 A, 20 A, 40 a. \$3.00

LONDON FIRE INSURANCE

Sound Mercantile Underwriters

LOSS AND DAMAGE PAID 8

LONG PRIMER (10 POINTS) CELTIC No. 3.
18 A, 18 A, 30 a. \$4.10

RICH COSTUME

Dramatic Combination

GRAND OPERA 2

14 A, 14 A, 20 a.

PICA (12 POINTS) CELTIC No. 3.

\$4.30

SOUTHERN EXPOSITIONS

Plantation and Mechanical Exhibits

INDUSTRIAL RESOURCES 8

10 A, 10 A, 15 a.

THREE-LINE NONPAREIL (18 POINTS) CELTIC No. 3.

\$5.45

SUMMER TOURISTS

Extensive Ocean Steamers

PLEASURE TRIPS 63

8 A, 8 A, 10 a.

TWO-LINE PICA (21 POINTS) CELTIC No. 2.

\$6.70

CONSTRUCTION

Modern Conveniences

RUSTIC HOMES 9

CELTIC No. 2.

AGATE CELTIC No. 2. (NONP. BODY, 6 POINTS.)
30 A, 30 A. \$3.25

JOS. DICKSON, MERCANTILE JOB PRINTER,
No. 845 WASHINGTON STREET, SAN FRANCISCO, CALIFORNIA. 728

MINION (7 POINTS) CELTIC No. 2.
20 A, 20 A. \$1.75

HANDSOME ENGRAVINGS
NATIONAL BANK-NOTE COMPANIES 8

LONG PRIMER (10 POINTS) CELTIC No. 2.
18 A, 18 A. \$2.20

CONGREGATIONS
MISSION MEETINGS 78

3-LINE NONPAREIL (18 POINTS) CELTIC No. 2.
10 A, 10 A. \$3.00

PRINTING
JOB PRESSES 6

NONPAREIL (6 POINTS) CELTIC No. 2.
35 A. \$1.40

EMINENT AMERICAN VOCALISTS
CINCINNATI DRAMATIC FESTIVALS, \$62

BREVIER (8 POINTS) CELTIC No. 2.
20 A, 20 A. \$2.10

PROMINENT JUDGE
SUPERIOR COURT REPORT 2

PICA (12 POINTS) CELTIC No. 2.
14 A, 14 A. \$2.20

UNION DEPOT
SCIOTO RAILROAD 1

TWO-LINE PICA (24 POINTS) CELTIC No. 2.
8 A, 8 A. \$4.00

DESIGN
FINE ART 8

6 A, 6 A.

FIVE-LINE NONPAREIL (30 POINTS) CELTIC No. 2.

\$5.00

INTERNAL
REVENUE OFFICE 1

5 A, 5 A.

THREE-LINE PICA (36 POINTS) CELTIC No. 2.

\$7.00

GRANITE
MONUMENTS, 9

4 A, 4 A.

SEVEN-LINE NONPAREIL (42 POINTS) CELTIC No. 2.

\$10.00

ARM IN ARM

Quads and Spaces extra.

69

Cincinnati Type Foundry, 201 Vine St.

NORMAN CONDENSED.

LONG PRIMER (10 POINTS) NORMAN CONDENSED.
20 A, 32 A. \$3.00

NORTHERN RAILROADS
FREIGHT AND PASSENGER DEPOT 17

3-LINE NONPAREIL (18 POINTS) NORMAN COND.
10 A, 16 A. \$3.40

COMPOSITIONS
POLITICAL SPEECHES 4

PICA (12 POINTS) NORMAN CONDENSED.
12 A, 20 A. \$3.20

FOREIGN MARKET
FINANCE AND COMMERCE 25

PARAGON (20 POINTS) NORMAN CONDENSED.
8 A, 12 A. \$4.00

FURNITURE
PICTURE FRAME 1

5 A, 8 A.

DBL. PICA (24 POINTS) NORMAN CONDENSED.

\$4.25

AMERICAN MANNERS
SELECTION OF CURIOSITIES, 63

4 A, 6 A.

THREE-LINE PICA (36 POINTS) NORMAN CONDENSED.

\$5.00

BRIGHT EASTER MORN 7

OLD STYLE COND. No. 3.

2-LINE PEARL (10 POINTS) OLD STYLE COND. No. 3.
24 A. \$1.80

GOVERNMENT ARMORIES 78

2-LINE BREV. (16 POINTS) OLD STYLE COND. No. 3.
16 A. \$2.00

SECRET MEETING 20

2-LINE NONP. (12 POINTS) OLD STYLE COND. No. 3.
30 A. \$1.65

DOMESTIC PRODUCTS 4

3-LINE NONP. (18 POINTS) OLD STYLE COND. No. 3.
12 A. \$2.40

CONSTRUCTION 16

10 A.

TWO-LINE SMALL PICA (22 POINTS) OLD STYLE CONDENSED No. 3.

\$2.70

ENTERPRISING MERCHANT 82

8 A.

TWO-LINE ENGLISH (28 POINTS) OLD STYLE CONDENSED No. 3.

\$3.60

NORTHERN PRODUCTS 6

6 A.

FOUR-LINE BREVIER (32 POINTS) OLD STYLE CONDENSED No. 3.

\$3.60

MORNING EDITIONS 8

Quads and Spaces extra.

70

Cincinnati Type Foundry, 201 Vine St.

OLD STYLE COND. No. 2.

PICA (12 POINTS) OLD STYLE CONDENSED No. 2.
16 A, 32 a. \$2.40

MOUNTAINOUS REGIONS
Cumberland River Scenery \$24

DBL. PICA (24 POINTS) OLD STYLE COND. No. 2.
6 A, 12 a. \$3.00

PRODUCERS
Annual Harvest 3

3-LINE NONP. (18 POINTS) OLD STYLE COND. No. 2.
10 A, 20 a. \$3.00

COMMISSIONERS
United States Bond \$86

PARAGON (20 POINTS) OLD STYLE COND. No. 2.
8 A, 16 a. \$2.65

SUMMER TOURS
Western Countries 62

4 A, 8 a. FOUR-LINE BREVIER (32 POINTS) OLD STYLE CONDENSED No. 2. \$4.50

PROGNOSTICATION
Astronomical Observation 6

3 A, 6 a. THREE-LINE PICA (36 POINTS) OLD STYLE CONDENSED No. 2. \$4.10

INTRENCHMENT
Tremendous Mountain 8

3 A, 5 a. SEVEN-LINE NONPAREIL (42 POINTS) OLD STYLE CONDENSED No. 2. \$5.50

FOUNDERIES
Beautiful Collection 6

3 A, 5 a. FOUR-LINE PICA (48 POINTS) OLD STYLE CONDENSED No. 2. \$6.00

Finest GOLD Pen 8

ROMIC.

30 A, 60 a. BREVIER (8 POINTS) ROMIC. \$3.00

LAMARTINE'S CELEBRATED MEMOIRS
Personal Memoirs of Heroic French Revolutionary Patriots
History of Constituent Assembly, 1785

20 A, 38 a. LONG PRIMER (10 POINTS) ROMIC. \$3.00

GENERAL ENDOWMENT PLANS
North Connecticut Mutual Insurance Association
Liabilities and Assets 1,234,567

15 A, 25 a. PICA (12 POINTS) ROMIC. \$3.00

EMINENT PRACTITIONERS
Supreme Courts of Ohio and Pennsylvania
Judgment Sustained 250

10 A, 16 a. THREE-LINE NONPAREIL (18 POINTS) ROMIC. \$4.00

COUNTRY RESIDENCE
Improvements and Conveniences
Finest Structures, 126

10 A, 16 a. PARAGON (20 POINTS) ROMIC. \$5.20

PENCIL PORTRAITS
School Board Regulations
Eminent Writers 2

8 A, 12 a. DOUBLE PICA (24 POINTS) ROMIC. \$6.10

COMMERCIAL
Business Educations
Arithmetic 24

FRENCH IONIC.

LONG PRIMER (10 POINTS) FRENCH IONIC.
20 A, 40 a. \$2.75

FIRE INSURANCE
American National Banks
Governments, \$67

PICA (12 POINTS) FRENCH IONIC.
20 A, 38 a. \$3.65

FRENCH POEM
Second Grand Concert
Exercises, 519

10 A, 20 a.

PARAGON (20 POINTS) FRENCH IONIC.

\$4.75

FREIGHT AGENTS
Indiana Central Railroad, 8

ENGLISH (14 POINTS) FRENCH IONIC.
15 A, 20 a. \$3.25

MERCHANTS
Commercial Notice
Markets, 14

THREE-LINE NONP. (18 POINTS) FRENCH IONIC.
10 A, 16 a. \$3.25

NUMBERS
Premium Award
Medals 51

6 A, 12 a.

FIVE-LINE NONPAREIL (30 POINTS) FRENCH IONIC.

\$4.30

PRODUCTION
Choice Monuments 5

6 A, 10 a.

SEVEN-LINE NONPAREIL (42 POINTS) FRENCH IONIC.

\$9.65

PRINTERS
Reservations 39

4 A, 6 a.

FOUR-LINE PICA (48 POINTS) FRENCH IONIC.

\$12.50

MINERS
Dominions 2

DIDOT + SERIES.

PICA (12 POINTS) DIDOT No. 3.
16 A. \$2.00

SPECULATION
PRODUCE + MERCHANT + 13

PICA (12 POINTS) DIDOT No. 1.
12 A. \$2.00

MINIATURE
BURNET + WOODS + 9

PICA (12 POINTS) DIDOT No. 2.
12 A. \$2.00

DELIGHTFUL
SOUTHERN + HOMES + 5

THREE-LINE NONPAREIL (18 POINTS) DIDOT No. 3.
10 A. \$2.25

PREMIUM
GOLD + MEDAL 2

10 A. THREE-LINE NONPAREIL (18 POINTS) DIDOT No. 2. \$2.50

ANNOUNCEMENT
GENERAL + REDUCTION + \$35

10 A. THREE-LINE NONPAREIL (18 POINTS) DIDOT No. 1. \$2.75

REMBRANDT
AMERICAN MINERALS 6

8 A. TWO-LINE PICA (24 POINTS) DIDOT. \$3.00

ANNUAL BANQUET 5

6 A. FIVE-LINE NONPAREIL (30 POINTS) DIDOT No. 2. \$3.50

GOVERNMENT + 8

6 A. FIVE-LINE NONPAREIL (30 POINTS) DIDOT No. 1. \$4.25

EXHIBITION + 2

Quads and Spaces extra.

7/4

Cincinnati Type Foundry, 201 Vine St.

COMBINATIONS.

Pica Didot No. 3 with Pica Didot No. 2.

TRUNK + MANUFACTORY.

Pica Didot No. 2 with Pica Didot No. 1.

HOLIDAY + NOVELTIES

Pica Didot No. 1 with Three-line Nonp. Didot No. 3.

ELECTRIC + LIGHT

Pica Didot No. 1 with Three-line Nonp. Didot No. 2.

RAILROAD GUIDE

Three-line Nonpareil Didot No. 3 with Three-line Nonpareil Didot No. 2.

MIAMI + PUBLISHING + COMPANY

Three-line Nonpareil Didot No. 2 with Three-line Nonpareil Didot No. 1.

+ MERCHANTS + EXCHANGE +

Three-line Nonpareil Didot No. 2 with Two-line Pica Didot.

* HANDSOME + BUILDINGS *

Three-line Nonpareil Didot No. 1 with Two-line Pica Didot.

ERIE + NATIONAL + BANK

Two-line Pica Didot with Five-line Nonpareil Didot No. 2.

+ GERMAN + EMPIRE +

Five-line Nonpareil Didot No. 2 with Five-line Nonpareil Didot No. 1.

CHOICE + MUSIC

Five-line Nonpareil Didot No. 1.

HEMISPHERE

Actual Lining of Didot Series.

HHHHHHHHHHHHHHHHHHHH

CONCAVE.

NONPAREIL (6 POINTS) CONCAVE.
30 A. \$1.30

FARMING IMPLEMENTS, \$27
TORONTO MANUFACTURING COMPANY

THREE-LINE NONPAREIL (18 POINTS) CONCAVE.
14 A. \$2.50

MEDICINES 19

LONG PRIMER (10 POINTS) CONCAVE.
22 A. \$1.30

ELECTRIC LIGHT 45
WONDERFUL INVENTIONS.

PICA (12 POINTS) CONCAVE.
18 A. \$1.75

FRESCO PAINTS 98

12 A. TWO-LINE LONG PRIMER (20 POINTS) CONCAVE. \$3.10

AMERICAN GROCERS, 35

10 A. TWO-LINE PICA (24 POINTS) CONCAVE. \$3.50

MORNING HOURS 28

8 A. FIVE-LINE NONPAREIL (30 POINTS) CONCAVE. \$3.80

FRENCH DESIGN 7

6 A. FOUR-LINE BREVIER (32 POINTS) CONCAVE. \$3.95

CONDUCTORS 4

4 A. THREE-LINE PICA (36 POINTS) CONCAVE. \$5.00

RESIDENT 6

FAHNESTOCK.

8 A. TWO-LINE PICA (24 POINTS) FAHNESTOCK. \$3.00

NORTHERN MINES, 54

6 A. THREE-LINE PICA (36 POINTS) FAHNESTOCK. \$4.50

PROMINENCE 3

4 A. FOUR-LINE PICA (48 POINTS) FAHNESTOCK. \$6.50

MENDER 2

Miscellaneous Blacks.

PICA (12 POINTS) BLACK No. 1.
8 A, 16 a. \$1.25

General Importers
Manufacturers of Hardware 25

3-LINE NONPAREIL (18 POINTS) BLACK No. 1.
6 A, 20 a. \$1.90

Educational
Intermediate Schools 76

4 A, 8 a.

PARAGON (20 POINTS) BLACK No. 1.

\$1.95

North American Benevolent Societies 39

18 A, 50 a.

BREVIER (8 POINTS) BOLD-FACE BLACK.

\$2.75

Transparent Varnishes for Printing Purposes
Manufacturers and Dealers in Standard Black and Colored Inks 824

8 A, 18 a.

THREE-LINE NONPAREIL (18 POINTS) BOLD-FACE BLACK.

\$4.00

The Stratton Mercantile Agency, 56

6 A, 16 a.

PARAGON (20 POINTS) BOLD-FACE BLACK.

\$4.00

Burnet House Restaurant, 37

THREE-LINE NONPAREIL (18 POINTS) MISSAL.
6 A, 10 a. \$1.50

California Merchants, 8

DBL. PICA (24 POINTS) MISSAL.
4 A, 10 a. \$2.25

Rocky Mountains 7

4 A, 12 a.

FIVE-LINE NONPAREIL (30 POINTS) MISSAL.

\$2.80

Hammonia Building Association, 48

4 A, 8 a.

SEVEN-LINE NONPAREIL (42 POINTS) MISSAL.

\$4.50

Handsome Specimens 578

4 A, 4 a.

CANON (48 POINTS) MISSAL.

\$5.00

Medical Journals 21

Quads and Spaces extra.

77

Cincinnati Type Foundry, #01 Vine St.

Initial Black Series.

- 20 A, 50 a. LONG PRIMER (10 POINTS) INITIAL BLACK. \$3.25
An Intermission, During which the Grand Orchestra will Perform
Choice Refreshments Served in the Elegant Salon, Overlooking the Beautiful River and Grounds 297
- 15 A, 35 a. PICA (12 POINTS) INITIAL BLACK. \$3.25
Jewelry and Fine Watches Made to Order at Short Notice
Light, Graceful Invitation Card Type, Programmes and Menus for Special Occasions 28
- 10 A, 25 a. ENGLISH (14 POINTS) INITIAL BLACK. \$3.00
Combination Borders Facilitating Artistic Expression
Determination to Exceed Previous Results in Typographic Ornamentation 47
- 8 A, 20 a. THREE-LINE NONPAREIL (18 POINTS) INITIAL BLACK. \$3.90
Cincinnati Horticultural Society's Exposition
Illustrated Catalogue Describing Various Western Plants 93
- 6 A, 14 a. DBL. PICA (24 POINTS) INITIAL BLACK. \$4.65
Cincinnati Type Foundry Specimens
Perfect Designs with Excellent Workmanship 8

Black Condensed No. 2.

- | | |
|--|--|
| ENGLISH (14 POINTS) BLACK CONDENSED NO. 2.
10 A, 30 a. \$1.40 | 3-LINE NONP. (18 POINTS) BLACK COND. NO. 2.
8 A, 20 a. \$1.75 |
| Montreal Publishing Company
Illustrated Magazines and Periodicals | Noted American Visitors
Vienna Industrial Expositions |
- 4 A, 8 a. FIVE-LINE NONPAREIL (30 POINTS) BLACK CONDENSED NO. 2. \$2.10
First Grand Complimentary Entertainment
- 4 A, 8 a. THREE-LINE PICA (36 POINTS) BLACK CONDENSED NO. 2. \$3.00
Our Improved Nonpareil Jobber

Miscellaneous Blacks.

- 15 A, 30 a. LONG PRIMER (10 POINTS) ARABESQUE. \$1.20
Marvelously Beautiful and Picturesque Landscape Reproductions
Views of Arabia's Celebrated Objects of Interest, with Descriptive Letterpress 54
- 10 A, 20 a. THREE-LINE NONPAREIL (18 POINTS) ARABESQUE. \$1.60
Elaborate Ball and Concert Printing
Plain or Ornamental Work in General Executed 376
- 6 A, 18 a. DBL. PICA (24 POINTS) ITALIAN TEXT. \$2.20
Morning and Evening Order of Services
Italian Artists, Painters, Sculptors and Musicians
- 8 A, 16 a. PARAGON (20 POINTS) BLACK NO. 4. \$1.85
Illuminated Manuscripts of Early History
Superior Printing Machinery and Fine Typographic Charms

Curlique.

- 6 A, 16 a. PARAGON (20 POINTS) CURLIQUE. \$4.20
Special Cotton Manufacturers
Extensive Displays of Farm Implements
Cincinnati Builders, &c
- 5 A, 10 a. FIVE-LINE NONPAREIL (30 POINTS) CURLIQUE. \$5.60
Sorgeous Initial Letters
American Printers' Excellence
Boston Common 76

Black Ornamented No. 3.

PICA (12 POINTS) BLACK ORNAMENTED No. 3.
10 A, 20 a. \$1.40

Improved Steam Engines
The Cincinnati Fire Department

3-LINE NONP. (18 POINTS) BLACK ORNA. No. 3.
8 A, 16 a. \$1.65

Extensive Shipments
Empire Steamship Lines.

6 A, 15 a.

PARAGON (20 POINTS) BLACK ORNAMENTED No. 3.

\$2.00

Cincinnati Type Foundry Catalogue
Specimens of Metal Corners and Flourishes

4 A, 6 a.

FIVE-LINE NONPAREIL (30 POINTS) BLACK ORNAMENTED No. 3.

\$2.10

Ohio Boards of Public Improvement.

4 A, 6 a.

FOUR-LINE BREVIER (32 POINTS) BLACK ORNAMENTED No. 3.

\$2.50

Albany Chamber of Commerce

Black Condensed No. 3.

PICA (12 POINTS) BLACK CONDENSED No. 3.
10 A, 20 a. \$1.40

Manufacturers of Cigars
Southern Tobacco Warehouses

3-LINE NONP. (18 POINTS) BLACK COND. No. 3.
8 A, 16 a. \$1.65

Important Periodicals
Mechanics' Home Journal

6 A, 15 a.

PARAGON (20 POINTS) BLACK CONDENSED No. 3.

\$2.00

United States Special Inspector
Pennsylvania and Kentucky Central Railroads.

4 A, 6 a.

FIVE-LINE NONPAREIL (30 POINTS) BLACK CONDENSED No. 3.

\$2.10

Mutual Life Insurance Companies.

4 A, 6 a.

FOUR-LINE BREVIER (32 POINTS) BLACK CONDENSED No. 3.

\$3.00

Dayton Commercial Advertiser

Wide Black.

BREVIER (8 POINTS) WIDE BLACK.
16 A, 40 a. \$3.00

Extensive Transportations
American Steamship Companies.
Accommodation, \$2457

LONG PRIMER (10 POINTS) WIDE BLACK.
14 A, 36 a. \$3.00

Manufacturing Jeweler
French and German Clocks
Chronometers, \$840

10 A, 24 a.

PICA (12 POINTS) WIDE BLACK.

\$3.00

Great Vineyard Region of California
The North American Wine Growers' Association
Select Champagne and Claret \$795

8 A, 20 a.

ENGLISH (14 POINTS) WIDE BLACK.

\$3.20

Wilmington Morning Chronicle
The Cincinnati Astronomical Observatory
Hudson Medical Institute, 932

6 A, 16 a.

TWO-LINE BREVIER (16 POINTS) WIDE BLACK.

\$3.00

The Cincinnati Type Foundry
Our Nonpareil and Reliable Job Press
Printing Machinery, 750

6 A, 16 a.

THREE-LINE NONPAREIL (18 POINTS) WIDE BLACK.

\$3.40

Princeton Weekly Monitor
Second National Bank of Richmond
United States Currency 68

5 A, 12 a.

PARAGON (20 POINTS) WIDE BLACK.

\$4.25

Westminster Tribune
Monroe Advertising Journal
Hamilton Review, 45

LAW ITALIC.

24 A, 80 a. \$3.15

BREVIER (8 POINTS) LAW ITALIC.

10 lbs., \$9.00

BE IT REMEMBERED, that on the day of , 1867, Richardson & Edmunds, of Cincinnati, have deposited in this office the Title of a Book, the right whereof they claim as Proprietors, in the words following, to-wit: "The Classical Reader," a Selection of Lessons in Prose. J. HUNTER, Clerk of District Court.

20 A, 70 a. \$3.60

LONG PRIMER (10 POINTS) LAW ITALIC.

10 lbs., \$7.40

THIS IS TO CERTIFY, that I have hired and taken of , of Cincinnati, Hamilton County, Ohio, a House and Lot known as No. 342 Franklin Street, of said City, for the Term of Four Years. C. ROSE.

18 A, 40 a. \$3.10

PICA (12 POINTS) LAW ITALIC.

10 lbs., \$6.60

RESOLVED, That the County Commissioners be authorized to pay to the sum of \$175 out of the first moneys received from the sale of Stock. J. DUNN, Auditor of Darke County.

COPPERPLATE ITALIC.

30 A, 60 a. \$2.75

LONG PRIMER (10 POINTS) COPPERPLATE ITALIC.

10 lbs., \$7.40

The continued and liberal patronage extended to us by our many Friends and the public is satisfactory proof that our efforts to accommodate have been appreciated. Having greatly increased our facilities, we can offer great inducements to buyers. CHAS. NOBLE.

15 A, 42 a. \$2.90

PICA (12 POINTS) COPPERPLATE ITALIC.

10 lbs., \$6.60

The Fourth Annual Meeting of the Joint Stockholders of the Atlantic and Great Western Railroad will be held next Thursday, December 19, at the Independence Hall, corner of Madison and Clinton streets. F. BURNETT, Pres.

12 A, 60 a. \$5.00

THREE-LINE NONPAREIL (18 POINTS) COPPERPLATE ITALIC.

10 lbs., \$6.00

We invite the attention of Booksellers, Stationers, and General Dealers to our stock of books, paper and stationery suitable to the wants of all dealers.

10 A, 60 a. \$5.75

PARAGON (20 POINTS) COPPERPLATE ITALIC.

10 lbs., \$5.60

The partnership heretofore existing between James Morgan and George Hubert has been dissolved by mutual consent, February 23d.

Scripts, etc.

LONG PRIMER (10 POINTS) ITALIC HAIR-LINE.
8 A, 30 a. \$1.50

HISTORICAL ROMANCE
Descriptive Account of South America
Standard Productions, \$78

PICA (12 POINTS) ITALIC HAIR-LINE.
8 A 16 a. \$1.60

SELECT RULES
Plain and Ornamental
Brass Dashes 25

PICA (12 POINTS) CALIGRAPHIC SCRIPT.
12 A, 60 a. \$3.50

Our Celebrated Temperance Lecturers
The Young Mens Christian Association, 16

3-LINE NONP. (18 POINTS) CALIGRAPHIC SCRIPT.
8 A, 50 a. \$4.00

William Henderson, President
Cincinnati Board of Education - 40

LG. PRIMER (10 POINTS) MADISONIAN SCRIPT.
6 A, 20 a. \$2.50

Domestic Manufactures
Cotton and Woollen Goods, 35

PICA (12 POINTS) MADISONIAN SCRIPT.
6 A, 30 a. \$3.40

Stop Cylinder Presses
Printing Machine Works 44

5 A, 16 a.

THREE-LINE NONPAREIL (18 POINTS) MADISONIAN SCRIPT.

\$3.00

Mandison, Pearce & Richards
Importers of Fine Musical Instruments, \$47

GREAT PRIMER SCRIPT No. 2.
8 A, 45 a. \$5.20

Freight Transportation
Adams Express Company 34

DBL. SMALL PICA SCRIPT No. 2.
5 A, 40 a. \$6.75

Williamson & Co.
Insurance Agents, 18

PICA (12 POINTS) UTILITY SCRIPT.
8 A, 45 a. \$3.15

National Military Parade
Annual Soldiers Re-union 20

3-LINE NONPAREIL (18 POINTS) UTILITY SCRIPT.
8 A, 46 a. \$5.75

North American
Government Bonds, 2

PICA (12 POINTS) HANCOCK SCRIPT.
8 A, 45 a. \$3.50

Important Engagements
American Opera Companies, \$25.

GREAT PRIMER HANCOCK SCRIPT.
8 A, 25 a. \$5.00

Trustee's Reports.
Merchants Exchange, 84

6 A, 30 a.

DBL. SMALL PICA HANCOCK SCRIPT.

\$5.00

Declaration of Independence.
Washington, 1776. John Hancock

Pen Text.

BREVIER (8 POINTS) PEN TEXT.
20 A, 60 a. \$3.60

Plate and Cylinder Distribution

Our Improved Nonpareil Job Printing Press
For Black and Colored Work 32

LONG PRIMER (10 POINTS) PEN TEXT.
8 A, 8 A, 50 a. \$4.20

Moorman, Hutchinson & Co.

Wholesale Commission Merchants,
No. 635 Franklin Street.

4 A, 4 A, 25 a.

THREE-LINE NONPAREIL (18 POINTS) PEN TEXT.

\$5.00

Specimens of Modern Inventions
Lithographing and Engraving Establishments
New Designs for Printers, \$46

PICA (12 POINTS) PEN TEXT.
6 A, 6 A, 36 a. \$1.35

The Manhattan Socials

Fourth Grand Entertainment
Admission, 25 Cents.

ENGLISH (14 POINTS) PEN TEXT.
4 A, 4 A, 25 a. \$4.70

Liquor Merchants

Imported French Brandy
Choice Cigars, 46

3 A, 3 A, 20 a.

PARAGON (20 POINTS) PEN TEXT.

\$5.20

Transportation Companies
Atlantic and Great Western Railroad.
Regular Daily Train, 82

3 A, 3 A, 20 a.

FIVE-LINE NONPAREIL (30 POINTS) PEN TEXT.

\$8.40

Insurance Agencies
Second National Bank \$35

3 A, 3 A, 10 a.

THREE-LINE PICA (36 POINTS) PEN TEXT.

\$9.00

Public Libraries
Hamilton Recorder, 8

Quads and Spacers extra.

84

Cincinnati Type Foundry, 201 Vine St.

Pen Text No. 2.

LONG PRIMER (10 POINTS) PEN TEXT NO. 2.
16 A, 50 a. \$2.90

The Reports of the Standing Committee
Regular Meetings of Cincinnati Board of Trade
Secretary's Annual Report, 1887

PICA (12 POINTS) PEN TEXT NO. 2.
12 A, 36 a. \$3.00

General Commission Merchants
Dealers in Foreign and Domestic Fruits
Regular Consignments \$59

ENGLISH (14 POINTS) PEN TEXT NO. 2.
8 A, 25 a. \$3.10

Engraver and Lithographer
Catalogue of Handsome Designs
Wedding Invitations 53

3-LINE NONPAREIL (18 POINTS) PEN TEXT NO. 2.
8 A, 25 a. \$3.90

Foreign Merchandise
Exports of Flour and Grain
Western Produce 24

PARAGON (20 POINTS) PEN TEXT NO. 2.
6 A, 20 a. \$4.10

American Papers
Stationer and Importer
Cardboard 7

DBL. PICA (24 POINTS) PEN TEXT NO. 2.
6 A, 20 a. \$5.40

Reliable Jobber
Printing Machines
Ornaments 2

4 A, 12 a.

THREE-LINE PICA (36 POINTS) PEN TEXT NO. 2.

\$6.75

Fourth National Bank
Money Order Department 38
Communication

3 A, 6 a.

FOUR-LINE PICA (48 POINTS) PEN TEXT NO. 2.

\$8.20

Home News, \$5
Dalton Advertiser

CARD LINE SERIES.

12 A, 8 A, 12 B.

PICA (12 POINTS) CARD LINE.

\$3.25

THE CINCINNATI SOUTHERN RAILROAD
Most Advantageous Route for Transportation of Freight, 345
GARDEN CITY 17489 BIRMINGHAM

8 A, 6 A, 14 B.

THREE-LINE NONPAREIL (18 POINTS) CARD LINE.

\$4.75

ARTISTIC EUROPEAN PRODUCTIONS
Beautiful Monuments of Grecian Architecture, \$284
GRANITE AND MARBLE WORKS

ROBINSON & COMSTOCK,
STATIONERS,
COMMERCIAL PRINTERS,
— AND —
Blank Book Manufacturers.

No. 26 SPRING LANE,

SANDUSKY, OHIO.

The Small Caps of Three-Line Nonpareil and Two-Line Pica sizes line by placing Nonpareil quads or reglets at the top.

BOUGHT OF THIRD NATIONAL BANK. RECEIVED

4 A, 6 A.

TWO-LINE PICA (24 POINTS) CARD LINE.

\$4.25

MODERN 25 DESIGNS
CARD ORNAMENTS AND FLOURISHES
SPECIMEN SHEETS, 873

Quads and Spaces extra.

86

Cincinnati Type Foundry, 201 Vine St.

Ornamental Type.

TWO-LINE NONPAREIL (12 POINTS) ORNA. NO. 39.
8 A. \$1.50

SONGS AND DANCES 36

TWO-LINE MINION (14 POINTS) ORNA. NO. 3.
10 A. \$1.50

PRINTING INKS 5

THREE-LINE NONP. (18 POINTS) ORNA. NO. 11.
12 A. \$2.00

EXHIBITS 5

TWO-LINE PICA (24 POINTS) ORNAMENTED NO. 26.
4 A. \$2.50

BROADAL 7

6 A. TWO-LINE LONG PRIMER (20 POINTS) ORNAMENTED NO. 13. \$2.00

PERFECT CHROMOTYPE 7

6 A. TWO-LINE LONG PRIMER (20 POINTS) ORNAMENTED NO. 6. \$2.00

OUR TYPOGRAPHIC CHARMS

4 A. 6 A. FIVE-LINE NONPAREIL (30 POINTS) ORNAMENTED NO. 26. \$4.00

NONPAREIL PRESS
Combination of Excellences 47

6 A. TWO-LINE LONG PRIMER (20 POINTS) ORNAMENTED NO. 9. \$2.00

ESTHETIC METHODS

6 A. TWO-LINE PICA (24 POINTS) ORNAMENTED NO. 16. \$2.00

IMPORTED CIGARS 50

TWO-LINE PICA (24 POINTS) ORNA. NO. 31.
6 A. \$2.00

BANGLE PIN

TWO-LINE MINION (14 POINTS) ORNA. NO. 16.
10 A. \$1.50

101 1st 1st 1st 1st 1st 1st 1st

1 A. FIVE-LINE NONPAREIL (30 POINTS) ORNAMENTED NO. 16. \$2.50

FINE REGALIA 11

4 A. FIVE-LINE NONPAREIL (30 POINTS) ORNAMENTED NO. 18. \$2.50

SPECIMEN SHEET

1 A. FOUR-LINE PICA (18 POINTS) ORNAMENTED NO. 1. \$3.50

CHOICE BUDS

Ornamental Type.

TWO-LINE NONPAREIL (12 POINTS) ORNA. No. 25.
10 A. \$1.50

ARTISTIC IRONWORK 8

THREE-LINE NONP. (18 POINTS) ORNA. No. 10.
10 A. \$2.00

AMERICAN WOOD 8

8 A.

TWO-LINE PICA (24 POINTS) ORNAMENTED No. 17.

\$2.00.

RUSTIC CHAIRS IN FLOWERY BEDS 3

4 A.

FOUR-LINE BREVIER (32 POINTS) ORNAMENTED No. 1.

\$3.00

BRONZE STATUES 8

NONPAREIL (6 POINTS) SHANGHAI.
40 A. \$2.50

**NOTED EUROPEAN OCCUPATIONS
FOREIGN COMMERCE AND AGRICULTURE 185
IMPORTANT CONCESSIONS**

PARAGON (20 POINTS) ORNAMENTED No. 23.
6 A, 6 a. \$3.00

**MAINE MONTHLY
Natural History of Birds**

TWO-LINE NONPAREIL (12 POINTS) ORNA. No. 4.
10 A. \$1.50

**TELEGRAPHIC
OBITUARY COLUMNS.**

TWO-LINE LONG PRIMER (20 POINTS) ORNA. No. 6.
8 A. \$2.00

EMIGRANTS

THREE-LINE NONP. (18 POINTS) GOTHIC ORNA.
12 A. \$2.50

BOMBARDMENT 1

TWO-LINE NONPAREIL (12 POINTS) ORNA. No. 16.
10 A. \$1.50

EXPEDITION PARTY

FIVE-LINE NONPAREIL (30 POINTS) ORNA. No. 14.
4 A. \$2.00

TO ADJOIN

TWO-LINE LG. PRIMER (20 POINTS) ORNA. No. 11.
8 A. \$2.00

BLACK GOODS

4 A.

TWO-LINE PICA (24 POINTS) ORNAMENTED No. 21.

\$2.00

THEATERS 3

6 A.

TWO-LINE PICA (24 POINTS) ORNAMENTED No. 30.

\$2.50

PRINTS EXECUTED 5

4 A.

THREE-LINE PICA (36 POINTS) ORNAMENTED No. 18.

\$3.00

PURE WINES 2

Quads and Spaces extra.

88

Cincinnati Type Foundry, 201 Vine St.

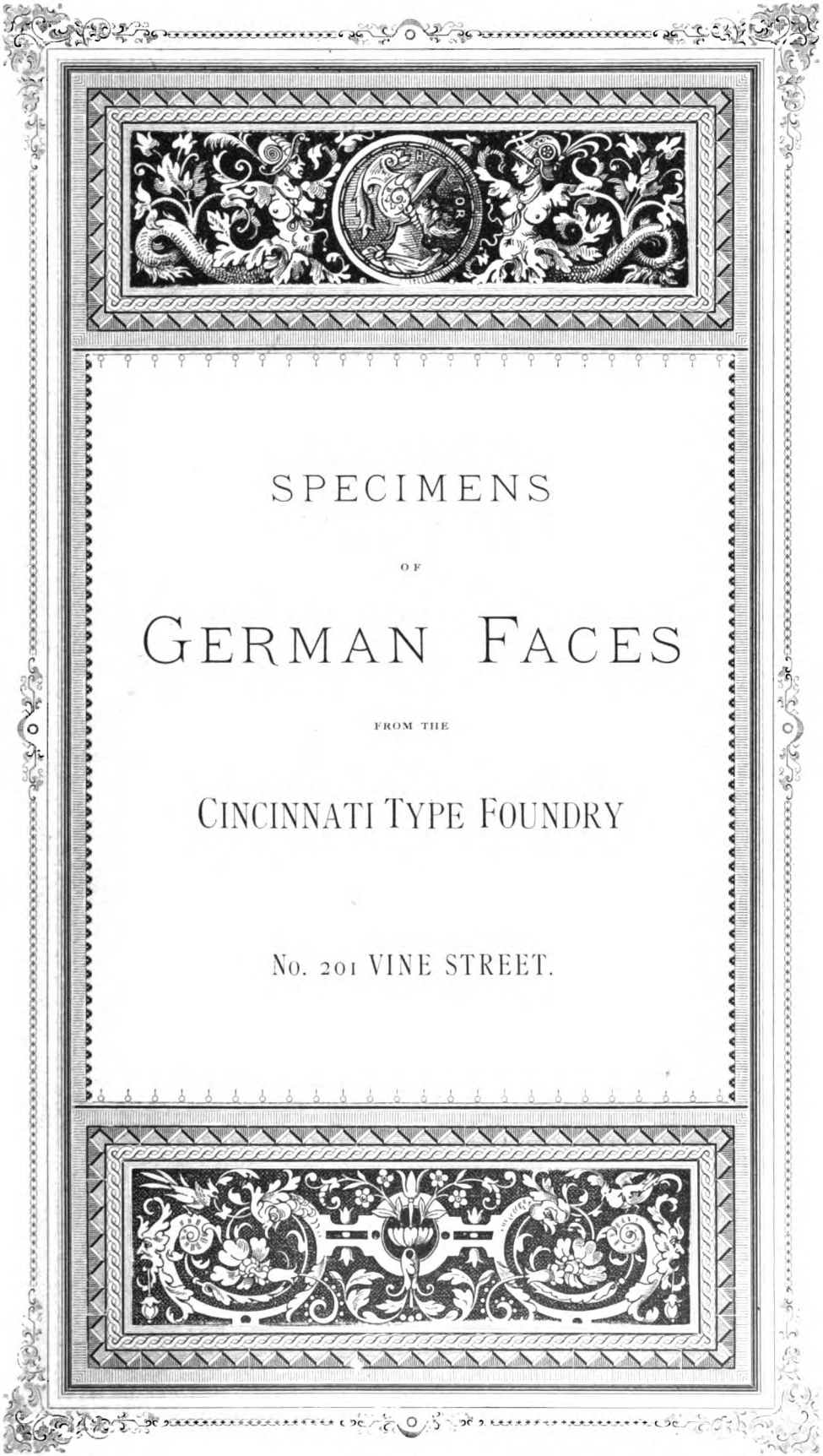

SPECIMENS
OF
GERMAN FACES

FROM THE
CINNATI TYPE FOUNDRY

No. 201 VINE STREET.

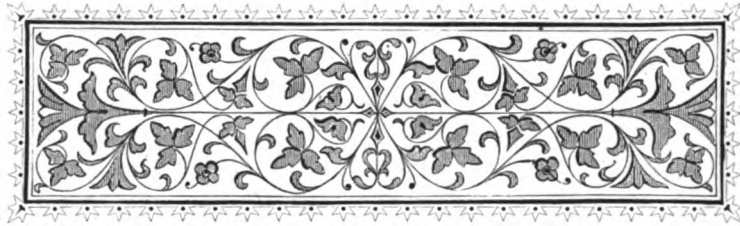

The Cincinnati Type Foundry,

NO. 201 VINE STREET,

Ist die älteste Schriftgiesserei des Westens — besteht seit 1820. Dieselbe hat dem Giessen deutscher Schriften, stets besondere Aufmerksamkeit geschenkt; die Zahl der von unsern Hause eingerichteten deutscher Druckereien ist eine grosse. Ausser Schriften liefern wir alle andern nöthigen Utensilien. Unsere guteingerrichtete Maschinenwerkstatt produzirt die überall bekannten Nonpareil Jobpressen, Cylinder- und Handpressen. Ueber die Qualität der von uns verfertigten Artikel zu sprechen, halten wir für unnöthig, da beinahe jeder Drucker dieses Landes weiss, dass alles von uns gelieferte Material fehlerfrei und preiswürdig ist.

Specimenbücher, Kostenanschläge und Pläne werden mit Vergnügen geliefert. Geneigten Aufträgen entgegenschend,

Cincinnati Type Foundry.



Standard German Faces.

NONPAREIL (6 POINTS) GERMAN No. 2.

Das Buch der Natur liegt seit Jahrtausenden aufgeschlagen vor dem Blicke des Menschen. Es ist in großen und herrlichen Zügen geschrieben, es enthält das Wunderbare und das Nützliche, und neben dem Glänzenden hat auch das Unscheinbare seine Bedeutung und seine Stelle. Zu allen Zeiten und aller Orten hat der Mensch die Sprache der Natur zu verstehen gesucht. Tausende haben dieselbe deshalb nicht nur flüchtig und obenhin, sondern mit Ernst und Tiefe betrachtet, und die ersten Geister der Menschheit waren bemüht, den Inhalt dieses Wertes verständlich und zugänglich zu machen. Und dennoch war der Erfolg dieses Strebens nur unvollständig, dennoch sind in diesem Buche noch viele Zeichen und Seiten, die wir nicht verstehen, die uns dunkel erscheinen und deren Zusammenhang mit anderen wir nur zu ahnen oder vermuthen vermögen. Aber so wie bei einer alten Inschrift der Inhalt hervortritt, wenn es gelingt, nach und nach die einzelnen Zeichen zu erkennen, so gelangte die Menschheit Schritt vor Schritt weiter im Verständnisse der Natur. Wie früh auch die Menschen der Naturbetrachtung sich zuwendeten, so geschah dies doch nicht immer mit gleicher Aufmerksamkeit. Ein so geheimnißvolles und wunderreiches Werk erfordert die Ruhe und Gelassenheit des Lesers. Aber diese finden wir selten, wenn wir zu der Geschichte der Völker früherer Zeiten hinaufsteigen. Da war so Vieles erst zu erwerben und einzurichten, daß nur selten der Einzelne Zeit gewann, einen flüchtigen Blick der Natur zuzuwenden. Da mußten vor Allem Staaten gegründet, geordnet und gesichert werden, und kaum fingen diese, meist nach unzähligen Kriegen und anderen Mühsalen an, sich zu erholen und befestigen, das Recht und Eigenthum begründet, und dem Bedürfnisse des religiösen Gefühles Genüge zu leisten, wozu hülfreich die beiteren Künste mitwirkten. Da

A B C D E F G H I J K L M N O P Q R S T U V W X Y Z
 abcdefghijklmnopqrstuvwxyz
 1234567890

BREVIER (8 POINTS) GERMAN No. 4.

Das Buch der Natur liegt seit Jahrtausenden aufgeschlagen vor dem Blicke des Menschen. Es ist in großen und herrlichen Zügen geschrieben, es enthält das Wunderbare und das Nützliche, und neben dem Glänzenden hat auch das Unscheinbare seine Bedeutung und seine Stelle. Zu allen Zeiten und aller Orten hat der Mensch die Sprache der Natur zu verstehen gesucht. Tausende haben dieselbe deshalb nicht nur flüchtig und obenhin, sondern mit Ernst und Tiefe betrachtet und die ersten Geister der Menschheit waren bemüht, den Inhalt dieses Wertes verständlich und zugänglich zu machen. Und dennoch war der Erfolg dieses Strebens nur unvollständig, dennoch sind in diesem Buche noch viele Zeichen und Seiten die wir nicht verstehen, die uns dunkel erscheinen, und deren Zusammenhang mit anderen wir nur zu ahnen oder vermuthen vermögen. Aber so wie bei einer alten Inschrift der Inhalt hervortritt, wenn es gelingt, nach und nach die einzelnen Zeichen zu erkennen, so gelangte die Menschheit Schritt vor Schritt weiter im Verständnisse der Natur. Wie früh auch die Menschen der Naturbetrachtung sich zuwendeten, so geschah dies doch nicht immer mit gleicher Aufmerksamkeit. Ein so geheimnißvolles und wunderreiches Werk erfordert die Ruhe und Gelassenheit des Lesers. Aber diese finden wir

A B C D E F G H I J K L M N O P Q R S T U V W X Y Z
 abcdefghijklmnopqrstuvwxyz
 1234567890

BREVIER (8 POINTS) GERMAN No. 5.

Das Buch der Natur liegt seit Jahrtausenden aufgeschlagen vor dem Blicke des Menschen. Es ist in großen und herrlichen Zügen geschrieben, es enthält das Wunderbare und das Nützliche, und neben dem Glänzenden hat auch das Unscheinbare seine Bedeutung und seine Stelle. Zu allen Zeiten und aller Orten hat der Mensch die Sprache der Natur zu verstehen gesucht. Tausende haben dieselbe deshalb nicht nur flüchtig und obenhin, sondern mit Ernst und Tiefe betrachtet und die ersten Geister der Menschheit waren bemüht, den Inhalt dieses Wertes verständlich und zugänglich zu machen. Und dennoch war der Erfolg dieses Strebens nur unvollständig, dennoch sind in diesem Buche noch viele Zeichen und Seiten die wir nicht verstehen, die uns dunkel erscheinen und deren Zusammenhang mit anderen wir nur zu ahnen oder vermuthen vermögen. Aber so wie bei einer alten Inschrift der Inhalt hervortritt, wenn es gelingt, nach und nach die einzelnen Zeichen zu erkennen, so gelangte die Menschheit Schritt vor Schritt weiter im Verständnisse der Natur. Wie früh auch die Menschen der Naturbetrachtung sich zuwendeten, so geschah dies doch nicht mit gleicher Aufmerksamkeit. Ein so geheimnißvolles und wunderreiches Werk erfordert die Ruhe und Gelassenheit des Lesers. Aber diese

A B C D E F G H I J K L M N O P Q R S T U V W X Y Z
 abcdefghijklmnopqrstuvwxyz
 1234567890

Standard German Faces.

NONPAREIL (6 POINTS) GERMAN No. 6.

Das Buch der Natur liegt seit Jahrtausenden aufgeschlagen vor dem Blicke des Menschen. Es ist in großen und herrlichen Zügen geschrieben, es enthält das Wunderbare und das Nützliche und neben dem Glänzenden hat auch das Unscheinbare seine Bedeutung und seine Stelle. Zu allen Zeiten und aller Orten hat der Mensch die Sprache der Natur zu verstehen gesucht. Tausende haben dieselbe deshalb nicht nur flüchtig und oberhin, sondern mit Ernst und Tiefe betrachtet, und die ersten Geister der Menschheit waren bemüht, den Inhalt dieses Werkes verständlich und zugänglich zu machen. Und dennoch war der Erfolg dieses Strebens nur unvollständig, dennoch sind in diesem Buche noch viele Zeichen und Seiten, die wir nicht verstehen, die uns dunkel erscheinen und deren Zusammenhang mit anderen wir nur zu ahnen oder vermuthen vermögen. Aber so wie bei einer alten Inschrift der Inhalt hervortritt, wenn es gelingt, nach und nach die einzelnen Zeichen zu erkennen, so gelangte die Menschheit Schritt vor Schritt weiter im Verständnisse der Natur. Wie früh auch die Menschen der Naturbetrachtung sich zuwendeten, so geschah dies doch nicht mit gleicher Aufmerksamkeit. Ein so geheimnißvolles und wunderreiches Werk erfordert die Ruhe und Gelassenheit des Lesers. Aber diese finden wir selten, wenn wir zu der Geschichte der Völker früherer Zeiten hinaufsteigen. Da war so Vieles erst zu erwerben und einzurichten, daß nur selten der Einzelne Zeit gewann, einen flüchtigen Blick der Natur zuzuwenden. Da mußten vor allem Staaten gegründet, geordnet, und gesichert werden, und kaum finget man, sich nach unzahligen Kriegen und anderen Mühsalen an, sich zu erholen und zu besessigen, das Recht und Eigenthum

A B C D E F G H I J K L M N O P Q R S T U V W X Y Z
abcdefghijklmnopqrstuvwxyz
1234567890

MINION (7 POINTS) GERMAN No. 6.

Das Buch der Natur liegt seit Jahrtausenden aufgeschlagen vor dem Blicke des Menschen. Es ist in großen und herrlichen Zügen geschrieben, es enthält das Wunderbare und das Nützliche, und neben dem Glänzenden hat auch das Unscheinbare seine Bedeutung und seine Stelle. Zu allen Zeiten und aller Orten hat der Mensch die Sprache der Natur zu verstehen gesucht. Tausende haben dieselbe deshalb nicht nur flüchtig und oberhin, sondern mit Ernst und Tiefe betrachtet, und die ersten Geister der Menschheit waren bemüht den Inhalt dieses Werkes verständlich und zugänglich zu machen. Und dennoch war der Erfolg dieses Strebens nur unvollständig, dennoch sind in diesem Buche noch viele Zeichen und Seiten die wir nicht verstehen, die uns dunkel erscheinen und deren Zusammenhang mit anderen wir nur zu ahnen oder vermuthen vermögen. Aber so wie bei einer alten Inschrift der Inhalt hervortritt, wenn es gelingt, nach und nach die einzelnen Zeichen zu erkennen, so gelangte die Menschheit Schritt vor Schritt weiter im Verständnisse der Natur. Wie früh auch die Menschen der Naturbetrachtung sich zuwendeten, so geschah dies doch nicht immer mit gleicher Aufmerksamkeit. Ein so geheimnißvolles und wunderreiches Werk erfordert die Ruhe und Gelassenheit des Lesers. Aber diese finden wir selten, wenn wir zu der Geschichte der Völker früherer Zeiten hinaufsteigen. Da war so Vieles erst zu erwerben und einzurichten, daß nur selten

A B C D E F G H I J K L M N O P Q R S T U V W X Y Z
abcdefghijklmnopqrstuvwxyz
1234567890

BREVIER (8 POINTS) GERMAN No. 6.

Das Buch der Natur liegt seit Jahrtausenden aufgeschlagen vor dem Blicke des Menschen. Es ist in großen und herrlichen Zügen geschrieben, es enthält das Wunderbare und das Nützliche und neben dem Glänzenden hat auch das Unscheinbare seine Bedeutung und seine Stelle. Zu allen Zeiten und aller Orten hat der Mensch die Sprache der Natur zu verstehen gesucht. Tausende haben dieselbe deshalb nicht nur flüchtig und oberhin, sondern mit Ernst und Tiefe betrachtet, und die ersten Geister der Menschheit waren bemüht, den Inhalt dieses Werkes verständlich und zugänglich zu machen. Und dennoch war der Erfolg dieses Strebens nur unvollständig, dennoch sind in diesem Buche noch viele Zeichen und Seiten die wir nicht verstehen, die uns dunkel erscheinen und deren Zusammenhang mit anderen wir nur zu ahnen oder vermuthen vermögen. Aber so wie bei einer alten Inschrift der Inhalt hervortritt, wenn es gelingt, nach und nach die einzelnen Zeichen zu erkennen so gelangte die Menschheit Schritt vor Schritt weiter im Verständnisse der Natur. Wie früh auch die Menschen der Naturbetrachtung sich zuwendeten, so geschah dies doch nicht immer mit gleicher Aufmerksamkeit. Ein so geheimnißvolles und wun-

A B C D E F G H I J K L M N O P Q R S T U V W X Y Z
abcdefghijklmnopqrstuvwxyz
1234567890

BOURGEOIS GERMAN No. 6 IN PREPARATION.

Standard German Faces.

BOURGEOIS (9 POINTS) GERMAN No. 3.

Das Buch der Natur liegt seit Jahrtausenden aufgeschlagen vor dem Blicke des Menschen. Es ist in großen und herrlichen Zügen geschrieben, es enthält das Wunderbare und das Nützliche, und neben dem Glänzenden hat auch das Unscheinbare seine Bedeutung und seine Stelle. Zu allen Zeiten und aller Orten hat der Mensch die Sprache der Natur zu verstehen gesucht. Tausende haben dieselbe deshalb nicht nur flüchtig und obenhin sondern mit Ernst und Tiefe betrachtet, und die ersten Geister der Menschheit waren bemüht, den Inhalt dieses Werkes verständlich und zugänglich zu machen. Und dennoch war der Erfolg dieses Strebens nur unvollständig, dennoch sind in diesem Buche noch viele Zeichen und Seiten, die wir nicht verstehen, die uns dunkel erscheinen und deren Zusammenhang mit anderen wir nur zu ahnen oder vermuthen vermögen. Aber so wie bei einer alten Inschrift der Inhalt hervortritt, wenn es gelingt, nach und nach die einzelnen Zeichen zu erkennen so gelangte die Menschheit Schritt vor Schritt weiter im Verständnisse der Natur Wie früh auch die

A B C D E F G H I J K L M N O P Q R S T U V W X Y Z
abcdefghijklmnopqrstuvwxyz
1234567890

LONG PRIMER (10 POINTS) GERMAN No. 3.

Das Buch der Natur liegt seit Jahrtausenden aufgeschlagen vor dem Blicke des Menschen. Es ist in großen und herrlichen Zügen geschrieben, es enthält das Wunderbare und das Nützliche, und neben dem Glänzenden hat auch das Unscheinbare seine Bedeutung und seine Stelle. Zu allen Zeiten und aller Orten hat der Mensch die Sprache der Natur zu verstehen gesucht. Tausende haben dieselbe deshalb nicht nur flüchtig und obenhin sondern mit Ernst und Tiefe betrachtet, und die ersten Geister der Menschheit waren bemüht den Inhalt dieses Werkes verständlich und zugänglich zu machen. Und dennoch war der Erfolg dieses Strebens nur unvollständig, dennoch sind in diesem Buche noch viele Zeichen und Seiten die wir nicht verstehen, die uns dunkel erscheinen und deren Zusammenhang mit andern wir nur zu ahnen oder vermuthen vermögen. Aber so wie bei einer alten Inschrift der Inhalt hervortritt, wenn es gelingt, nach und nach die

A B C D E F G H I J K L M N O P Q R S T U V W X Y Z
abcdefghijklmnopqrstuvwxyz
1234567890

LONG PRIMER (10 POINTS) GERMAN No. 6.

Das Buch der Natur liegt seit Jahrtausenden aufgeschlagen vor dem Blicke des Menschen. Es ist in großen und herrlichen Zügen geschrieben, es enthält das Wunderbare und das Nützliche, und neben dem Glänzenden hat auch das Unscheinbare seine Bedeutung und seine Stelle. Zu allen Zeiten und aller Orten hat der Mensch die Sprache der Natur zu verstehen gesucht. Tausende haben dieselbe deshalb nicht nur flüchtig und obenhin, sondern mit Ernst und Tiefe betrachtet, und die ersten Geister der Menschheit waren bemüht den Inhalt dieses Werkes verständlich und zugänglich zu machen. Und dennoch war der Erfolg dieses Strebens nur unvollständig, dennoch sind in diesem Buche noch viele Zeichen und Seiten die wir nicht verstehen, die uns dunkel erscheinen und deren Zusammenhang mit anderen wir nur zu ahnen oder ver-

A B C D E F G H I J K L M N O P Q R S T U V W X Y Z
abcdefghijklmnopqrstuvwxyz
1234567890

Standard German Faces.

LONG PRIMER (10 POINTS) GERMAN No. 4.

Das Buch der Natur liegt seit Jahrtausenden aufgeschlagen vor dem Blicke des Menschen. Es ist in großen und herrlichen Zügen geschrieben, es enthält das Wunderbare und das Nützliche, und neben dem Glänzenden hat auch das Unscheinbare seine Bedeutung und seine Stelle. Zu allen Zeiten und aller Orten hat der Mensch die Sprache der Natur zu verstehen gesucht. Tausende haben dieselbe deßhalb nicht nur flüchtig und obenhin, sondern mit Ernst und Tiefe betrachtet, und die ersten Geister der Menschheit waren bemüht, den Inhalt dieses Werkes verständlich und zugänglich zu machen. Und dennoch war der Erfolg dieses Strebens nur unvollständig, dennoch sind in diesem Buche noch viele Zeichen und Seiten, die wir nicht verstehen, die uns dunkel erscheinen und deren Zusammenhang mit anderen mir nur zu ahnen oder vermuthen vermögen. Aber so wie bei einer alten Inschrift der Inhalt hervor-

A B C D E F G H I J K L M N O P Q R S T U V W X Y Z
abcdefghijklmnopqrstuvwxyz
1234567890

SMALL PICA (11 POINTS) GERMAN No. 2.

Das Buch der Natur liegt seit Jahrtausenden aufgeschlagen vor dem Blicke des Menschen. Es ist in großen und herrlichen Zügen geschrieben, es enthält das Wunderbare und das Nützliche, und neben dem Glänzenden hat auch das Unscheinbare seine Bedeutung und seine Stelle. Zu allen Zeiten und aller Orten hat der Mensch die Sprache der Natur zu verstehen gesucht. Tausende haben dieselbe deßhalb nicht nur flüchtig und obenhin, sondern mit Ernst und Tiefe betrachtet, und die ersten Geister der Menschheit waren bemüht den Inhalt dieses Werkes verständlich und zugänglich zu machen. Und dennoch war der Erfolg dieses Strebens nur unvollständig, dennoch sind in diesem Buche noch viele Zeichen und Seiten die wir nicht verstehen, die uns dunkel erscheinen und deren Zusammen-

A B C D E F G H I J K L M N O P Q R S T U V W X Y Z
abcdefghijklmnopqrstuvwxyz
1234567890

PICA (12 POINTS) GERMAN No. 1.

Das Buch der Natur liegt seit Jahrtausenden aufgeschlagen vor dem Blicke des Menschen. Es ist in großen und herrlichen Zügen geschrieben, es enthält das Wunderbare und das Nützliche und neben dem Glänzenden hat auch das Unscheinbare seine Bedeutung und seine Stelle. Zu allen Zeiten und aller Orten hat der Mensch die Sprache der Natur zu verstehen gesucht. Tausende haben dieselbe deßhalb nicht nur flüchtig und obenhin, sondern mit Ernst und Tiefe betrachtet, und die ersten Geister der Menschheit waren bemüht, den Inhalt dieses Werkes verständlich und zugänglich zu machen. Und dennoch war der Erfolg dieses Strebens nur unvollständig, dennoch sind in

A B C D E F G H I J K L M N O P Q R S T U V W X Y Z
abcdefghijklmnopqrstuvwxyz
1234567890

Roman Faces, with German Accents.

LONG PRIMER (10 POINTS) No. 8 (With German Accents).

Das Buch der Natur liegt seit Jahrtausenden aufgeschlagen vor dem Blicke des Menschen. Es ist in grossen und herrlichen Zügen geschrieben, es enthält das Wunderbare und das Nützliche und neben dem Glänzenden hat auch das Unscheinbare seine Bedeutung und seine Stelle. Zu allen Zeiten und aller Orten hat der Mensch die Sprache der Natur zu verstehen gesucht. Tausende haben dieselbe nicht nur flüchtig und obenhin, sondern mit Ernst und Tiefe betrachtet, und die ersten Geister der Menschheit waren bemüht, den Inhalt dieses Werkes verständlich und zugänglich zu machen. Und dennoch war der Erfolg dieses Strebens nur unvollständig, dennoch sind in diesem Buche noch viele Zeichen und Seiten die wir nicht

ABCDEF GHIJK LMNOP QRSTUV WXYZ
ABCDEF GHIJK LMNOP QRSTUV WXYZ
· abcdefghijklmnopqrstuvwxyz äöü
1 2 3 4 5 6 7 8 9 0

LONG PRIMER (10 POINTS) No. 11 (With German Accents).

Das Buch der Natur liegt seit Jahrtausenden aufgeschlagen vor dem Blicke des Menschen. Es ist in grossen und herrlichen Zügen geschrieben, es enthält das Wunderbare und das Nützliche und neben dem Glänzenden hat auch das Unscheinbare seine Bedeutung und seine Stelle. Zu allen Zeiten und aller Orten hat der Mensch die Sprache der Natur zu verstehen gesucht. Tausende haben dieselbe nicht nur flüchtig und obenhin, sondern mit Ernst und Tiefe betrachtet, und die ersten Geister der Menschheit waren bemüht, den Inhalt dieses Werkes verständlich und zugänglich zu machen. Und dennoch war der Erfolg dieses Strebens nur unvollständig, dennoch sind in

ABCDEF GHIJK LMNOP QRSTUV WXYZ
ABCDEF GHIJK LMNOP QRSTUV WXYZ
· abcdefghijklmnopqrstuvwxyz äöü
1 2 3 4 5 6 7 8 9 0

LONG PRIMER (10 POINTS) No. 13 (With German Accents).

Das Buch der Natur liegt seit Jahrtausenden aufgeschlagen vor dem Blicke des Menschen. Es ist in grossen und herrlichen Zügen geschrieben, es enthält das Wunderbare und das Nützliche und neben dem Glänzenden hat auch das Unscheinbare seine Bedeutung und seine Stelle. Zu allen Zeiten und aller Orten hat der Mensch die Sprache der Natur zu verstehen gesucht. Tausende haben dieselbe nicht nur flüchtig und obenhin, sondern mit Ernst und Tiefe betrachtet, und die ersten Geister der Menschheit waren bemüht, den Inhalt dieses Werkes verständlich und zugänglich zu machen. Und dennoch war der Erfolg dieses Strebens nur unvollständig, dennoch sind in diesem Buche noch

ABCDEF GHIJK LMNOP QRSTUV WXYZ
ABCDEF GHIJK LMNOP QRSTUV WXYZ
· abcdefghijklmnopqrstuvwxyz äöü
1 2 3 4 5 6 7 8 9 0

German Titles.

NONPAREIL (6 POINTS) GERMAN TITLE NO. 2.
25 A, 60 a. \$3.75

**Wissenschaftliche Akademie-Berichte
Leben und Wirken Friedrichs des Großen.
Humoristische Gedichte, \$8950**

BREVIER (8 POINTS) GERMAN TITLE NO. 1.
15 A, 45 a. \$2.70

**Die Kandidaten und Beamten
Republikanische Staats Convention.
Inländische Nachrichten 643**

LG. PRIMER (10 POINTS) GERMAN TITLE NO. 1.
14 A, 30 a. \$3.10

**Himmel und Erde 23
Abeßinien und Senegambien**

BREVIER (8 POINTS) GERMAN TITLE NO. 2.
15 A, 45 a. \$2.70

**Geheimnisse der Sternenwelt
Wanderungen durch Nord Amerika.
Geographische Studien 17**

3-LINE EXCELSIOR (9 POINTS) GERMAN TITLE NO. 1.
12 A, 40 a. \$2.85

**Schillers sämtliche Werke
Wörterbuch der englischen Sprache.
Gemälde Handlung, 938**

LG. PRIMER (10 POINTS) GERMAN TITLE NO. 2.
14 A, 30 a. \$3.10

**Poetische Gedanken, 43
Allgemeines Familienjournal.**

12 A, 30 a.

PICA (12 POINTS) GERMAN TITLE NO. 1.

\$3.45

**Studium der Geographie und Botanik 58
Sitten und Lebensbilder des achtzehnten Jahrhunderts**

12 A, 30 a.

PICA (12 POINTS) GERMAN TITLE NO. 2.

\$3.45

**Zeitschrift für Kunst und Litteratur, 56
Hundertjähriger Geburtstag Alexander von Humboldts**

German Title Condensed.

BREVIER (8 POINTS) GER. TITLE COND. NO. 1.
15 A, 40 a. \$2.75

**Amerikanische Unterstützungs Verein
Germania Lebens-Versicherung Gesellschaft
Die Beamten und Mitglieder, \$390**

LG. PRIMER (10 POINTS) GER. TITLE COND. NO. 1.
12 A, 40 a. \$3.25

**Oestreich, England, Frankreich
Die Eröffnung der Friedensconferenz
Europäische Congress 62**

9 A, 30 a.

PICA (12 POINTS) GERMAN TITLE CONDENSED NO. 1.

\$2.50

**Geschichte der Gegenwart und Vergangenheit, \$450
Prachtvolle Lebensbilder deutscher Denker und Dichterheroen der Neuzeit.**

7 A, 20 a.

THREE-LINE NONPAREIL (18 POINTS) GERMAN TITLE CONDENSED NO. 1.

\$3.45

**Kostenanschläge und Specimenbücher, 43
Cincinnati Cylinder Pressen für Zeitungs Druckereien**

MISCELLANEOUS.

NONPAREIL (6 POINTS) GER. TITLE COND. No. 2.
15 A, 50 a. \$2.15

Gemeineigentum Bieler, und das nachkommende Ge

MINION (7 POINTS) GER. TITLE COND. No. 2.
15 A, 50 a. \$2.45

Der Zusammenhang der Umstände, der Natur

BREVIER (8 POINTS) GER. TITLE COND. No. 2.
15 A, 50 a. \$2.60

Durch äußere Umstände, meistens durch die

BOURGEOIS (9 POINTS) GER. TITLE COND. No. 2.
15 A, 50 a. \$2.85

Menschen und Sitten der Unterbrach und

LONG PRIMER (10 POINTS) GER. TITLE CON. No. 2.
12 A, 40 a. \$2.55

Rüdesheim Graudenz Emskirch Ant-

SMALL PICA (11 POINTS) GER. TITLE COND. No. 2.
9 A, 30 a. \$2.05

Herzberg Solothurn Uermark Ulm

PICA (12 POINTS) GERMAN TITLE COND. No. 2.
9 A, 30 a. \$2.50

Mährchen und Jugendschriften

ENGLISH (14 POINTS) GER. TITLE COND. No. 2.
8 A, 25 a. \$2.60

Eisenbahn von St. Louis na

GT. PRIMER (18 POINTS) GER. TITLE CON. No. 2.
7 A, 20 a. \$3.15

Rokomo, an Möllenbeck

DBL. SM. PICA (22 POINTS) GER. TIT. CON. No. 2.
7 A, 20 a. \$4.00

Schiller's Denkmal

DBL. ENGLISH (28 POINTS) GER. TITLE CON. No. 2.
4 A, 10 a. \$4.10

Albrecht Dürer

DBL. PAR. (40 POINTS) GER. TITLE COND. No. 2.
3 A, 6 a. \$4.00

Rhein, Jena

*GREAT PRIMER (18 POINTS) GERMAN No. 5.
20 A, 100 a. \$12.48

Die Gerichtsbarkeit der

*DBL. SMALL PICA (22 POINTS) GERMAN No. 5.
14 A, 18 a. \$12.00

Wenn man sich der

*DBL. ENGLISH (28 POINTS) GERMAN No. 5.
8 A, 60 a. \$12.00

Und doch wäre,

GT. PRIMER (18 POINTS) GERMAN TITLE No. 2.
7 A, 20 a. \$3.75

Soldh eine Moment

DBL. SMALL PICA (22 POINTS) GER. TITLE No. 2.
7 A, 20 a. \$4.75

Goethe in Bittau

DBL. ENGLISH (28 POINTS) GERMAN TITLE No. 2.
4 A, 10 a. \$4.85

Besth, Bern

DBL. GT. PRIMER (36 POINTS) GER. TITLE No. 2.
3 A, 6 a. \$4.10

Germania

DBL. PARAGON (40 POINTS) GERMAN TITLE No. 2.
3 A, 6 a. \$4.80

Erbachau

*FOUR-LINE PICA (48 POINTS) GERMAN.
6 A, 10 a. \$10.45

Schiller.

*FIVE-LINE PICA (60 POINTS) GERMAN No. 1.
4 A, 8 a. \$12.75

Entene

Schwabacher.

NONPAREIL (6 POINTS) SCHWABACHER. 15 A. 50 a. \$2.00. Das Pferd ist eines der nützlichsten Haus Thiere 8632	BREVIER (8 POINTS) SCHWABACHER. 15 A. 50 a. \$2.50. Die Urtschen Celtischen und Slavischen 985
LONG PRIMER (10 POINTS) SCHWABACHER. 12 A. 40 a. \$2.45. Vereinigten Staaten von Amerika 16	PICA (12 POINTS) SCHWABACHER. 9 A. 30 a. \$2.35. Das Lehrbuch der Religion 97
9 A. 30 a. Geschichte der deutschen Literatur mit ausgewählten 49	ENGLISH (14 POINTS) SCHWABACHER. \$3.15
5 A. 15 a. Geschichte der deutschen Literatur 24	PARAGON (20 POINTS) SCHWABACHER. \$3.15
5 A. 15 a. Stücken aus den Werken 38	FIVE-LINE NONPAREIL (30 POINTS) SCHWABACHER. \$5.45
4 A. 10 a. Friedrich von Schiller 6	SIX-LINE NONPAREIL (36 POINTS) SCHWABACHER. \$5.65
4 A. 10 a. Das Vaterland 5	EIGHT-LINE NONPAREIL (48 POINTS) SCHWABACHER. \$9.70

24 LBS.	PARAGON (20 POINTS) GERMAN.	\$9.12
---------	-----------------------------	--------

Das Buch der Natur liegt seit Jahrtausenden aufgeschlagen vor dem Blicke des Menschen und ist in großen und herrlichen Zügen geschrieben, es enthält das Wunder Deutsche Buchstaben, 3790

Wide Black.

BREVIER (8 POINTS) WIDE BLACK.
16 A, 40 n. \$3.00

Schiller's sämtliche Werke
Mit Biographien und Porträts 19

PICA (12 POINTS) WIDE BLACK.
10 A, 24 n. \$3.00

Ornament Malerei
Wunder des Orientes, 3

LONG PRIMER (10 POINTS) WIDE BLACK.
14 A, 36 n. \$3.00

Englische Schauspieler
Anekdoten und Geschichten 6

ENGLISH (14 POINTS) WIDE BLACK.
8 A, 20 n. \$3.20

Bundes-Zeitung
Populäre Melodie, 8

6 A, 16 n.

TWO-LINE BREVIER (16 POINTS) WIDE BLACK.

\$3.00

Palmengarten in Frankfurt
Die Cincinnati Industrie Ausstellung, 19

6 A, 16 n.

THREE-LINE NONPAREIL (18 POINTS) WIDE BLACK.

\$3.40

Sonaten alter Komponisten
Südliche Eisenbahn Gesellschaften, 47

5 A, 12 n.

PARAGON (20 POINTS) WIDE BLACK.

\$4.25

Atlantischer Telegraph
Deutsche Familien Kalender, 2

Bold-Face Black.

18 A, 50 n.

BREVIER (8 POINTS) BOLD-FACE BLACK.

\$2.75

Encyclopädie der Völker- und Staatenkunde 336
Die Organisation und der Geschäftsbetrieb des deutschen Buchhandels

8 A, 18 n.

THREE-LINE NONPAREIL (18 POINTS) BOLD-FACE BLACK.

\$4.00

Mexikanische Revolutionen
Schweizerische Eidgenossenschaft, 136

6 A, 16 n.

PARAGON (20 POINTS) BOLD-FACE BLACK.

\$4.00

Prachtvolles Gebäude
Dramatische Unterhaltung, 28

Pen Text.

BREVIER (8 POINTS) PEN TEXT.
20 A, 60 a. \$3.60

Das Kind in Freud und Leid
Verein für Naturheilkunde zu Frankenberg
Evangelisches Choralbuch \$243

LONG PRIMER (10 POINTS) PEN TEXT.
8 A, 8 A, 50 a. \$4.20

Illustration der Gartenlaube
Geschäfts-Ordnung des Bundesraths
Schiller und Goethe 654

4 A, 4 A, 25 a.

THREE-LINE NONPAREIL (18 POINTS) PEN TEXT.

\$5.00

Künstlerverein zu Frankfurt
Führer durch Hannover und seine Vorstädte
Monumente von Schiller \$6238

PICA (12 POINTS) PEN TEXT.
6 A, 6 A, 36 a. \$4.35

Oberkirchen Stralsund
Lehr-Institut Schützen-Fest
Das Passionspiel 75

ENGLISH (14 POINTS) PEN TEXT.
4 A, 4 A, 25 a. \$4.70

Lieder für Sopran
Briefe an eine Jungfrau
Haus-Lexikon 98

3 A, 3 A, 20 a.

PARAGON (20 POINTS) PEN TEXT.

\$5.20

Akademie der Tonkunst
Wegweiser für den Schreibunterricht
Witterungs-Bericht \$763

3 A, 3 A, 20 a.

DOUBLE ENGLISH (28 POINTS) PEN TEXT.

\$8.40

Münchener Journal
Atlas für Mädchenschulen
Intelligenzblatt 20

3 A, 3 A, 10 a.

THREE-LINE PICA (36 POINTS) PEN TEXT.

\$9.00

Fabrik-Gesetz
Bingen und Lübeck

Quads and Spaces extra.

100

Cincinnati Type Foundry, 201 Vine St.

MISCELLANEOUS.

10 A, 20 a.

PICA (12 POINTS) BLACK CONDENSED NO. 3.

\$1.40

Witterungsbericht der Sternwarte zu Hamburg
Organisation und der Geschäftsbetrieb des deutschen Buchhandels

6 A, 15 a.

PARAGON (20 POINTS) BLACK CONDENSED NO. 3.

\$2.00

Königliches Conservatorium für Musik
Ausstellungen von Kunstwerken der Bildhauerei.

THREE-LINE NONPAREIL (18 POINTS) MISSAL.
6 A, 10 a. \$1.50

Schiller's Werke
Deutsches Volkshuch 2

DOUBLE PICA (24 POINTS) MISSAL.
4 A, 10 a. \$2.25

Erklärung &
Kürner Frankfurt.

4 A, 12 a.

DOUBLE ENGLISH (28 POINTS) MISSAL.

\$2.80

Frühlings-Unterhaltung
Palmen-Gärten in Bremerbünde 3

4 A, 8 a.

DOUBLE PARAGON (40 POINTS) MISSAL.

\$4.50

Konrad Strinan 7
Gannhäuser Hugenotten

4 A, 4 a.

CANON (48 POINTS) MISSAL.

\$5.00

Würfelsbücher
General Konsulat 1

MISCELLANEOUS.

BREVIER (8 POINTS) ROMIC.
24 A, 50 a. \$3.00

GOETHE'S EGMONT

Schillers sämtliche Werke 8

Neue Wörterbücher

THREE-LINE NONPAREIL (18 POINTS) ROMIC.
10 A, 16 a. \$4.00

LEXIKON

Schützen Fest 3

LONG PRIMER (10 POINTS) ROMIC.
20 A, 38 a. \$3.00

GEDENKTAFEL

Geschäfts Kalender 248

Muster-Blätter

PICA (12 POINTS) ROMIC.
15 A, 25 a. \$3.00

DARMSTADT

Märchen Bücher 391

10 A, 16 a.

PARAGON (20 POINTS) ROMIC.

\$5.20

GARTEN CONCERT

Blühender Weinstock, 463

8 A, 12 a.

DOUBLE PICA (24 POINTS) ROMIC.

\$6.10

ZEITSCHRIFT

Museum für Kunst 6

1 A, 6 a.

DOUBLE ENGLISH (28 POINTS) FRENCH CLARENDON EXTENDED.

\$7.15

BADEN

Dänemark 1

3 A, 4 a.

THREE-LINE PICA (36 POINTS) FRENCH CLARENDON EXTENDED.

\$8.70

EISEN

Hühner 7



Initials, Monograms, Newspaper Headings.



ORNAMENTAL INITIALS.

SERIES No. 40.

/ Per set of 26 Letters. \$1.00.

A B C D E F G H I J K L M N O P

SERIES No. 41.

Per set of 26 Letters, \$1.25.

Q R S T U V W X Y Z A B C

SERIES No. 42.

Per set of 26 Letters, \$2.00.

D E F G H I J K L M N

SERIES No. 43.

Per set of 26 Letters, \$3.50.

O P Q R S T U V

SECOND NATIONAL BANK.

LEARNING by study must be won;
'Twas ne'er entailed from sire to son.

SAY where is he, or who may he be,
That can rival the printer's power.

OFFICE OF THE

CINCINNATI TYPE FOUNDRY,

No. 201 VINE STREET.

TO thee I dedicate these leaves,
Torn from the forest nooks
When blue-eyed Summer laid her hand
Upon the wood, and through its limbs
Breathed living joy and love.

AND if we do but watch the hour,
There never yet was human power
Which could evade, if unforgiven,
The patient search and vigil long
Of him who treasures up a wrong.

BOUGHT OF

MONTHLY STATEMENT

RECEIVED

Fancy Initials.

SERIES No. 34.

Single Letter, 20 cents; per set of 25 Letters, \$1.00.



SERIES No. 35.

Single Letter, 25 cents; per set of 25 Letters, \$1.25.



SERIES No. 36.

Single Letter, 30 cents; per set of 25 Letters, \$2.00.



Reunion.

RECEPTION.

Sociable.

Mr. & Mrs. Frank Hamilton,



Thursday Evening, December 26th, eight o'clock,

No. 32 Sylvan Avenue.

Chester Warren Literary Assembly.

INITIALS.

SERIES No. 38.

Single Letters, 10 cents; per set of 26 Letters, \$1.00.

A B C D E F G H I J K L

SERIES No. 39.

Single Letters, 10 cents; per set of 26 Letters, \$1.00.

M N O P Q R S T

SERIES No. 44.

Single Letters, 10 cents; per set of 26 Letters, \$1.00.

A B C D E F G H I J K L

SERIES No. 49.

Single Letters, 15 cents; per set of 26 Letters, \$1.25.

M N O P Q R S T U V

SERIES No. 50.

Single Letters, 20 cents; per set of 26 Letters, \$1.75.

W X Y Z A B C D E

SERIES No. 51.

Single Letters, 25 cents; per set of 26 Letters, \$2.25.

F G H I J K L

SERIES No. 52.

Single Letters, 30 cents; per set of 26 Letters, \$3.50.

M N O P S

Nos. 44, 49-52 for one or two colors.

Nos. 44, 49, 50, 51, 52 Patented, March 20, 1883.

→ Initials. ←

PATENTED.

MARCH 20, 1883.

SERIES No. 45.

Single Letters, 15 cents; per set of 26 Letters, \$1.25.

A R G I P H O N A L

SERIES No. 46.

Single Letters, 20 cents; per set of 26 Letters, \$1.75.

Q O N A S G I Q

SERIES No. 47.

Single Letters, 25 cents; per set of 26 Letters, \$2.25.

S T P E R B

SERIES No. 48.

Single Letters, 30 cents; per set of 26 Letters, \$3.50.

N A M E S

Ohio Merchants Bank

UNIVERSAL GEOGRAPHY.

To Bought of Or.

ORNAMENTAL INITIALS.

SERIES No. 53.

Single Letters, 25 cents; per set of 26 Letters, \$2.25.

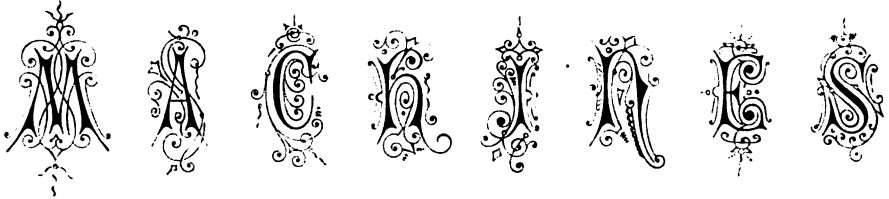

SERIES No. 54.

Single Letters, 30 cents; per set of 25 Letters, \$3.50.

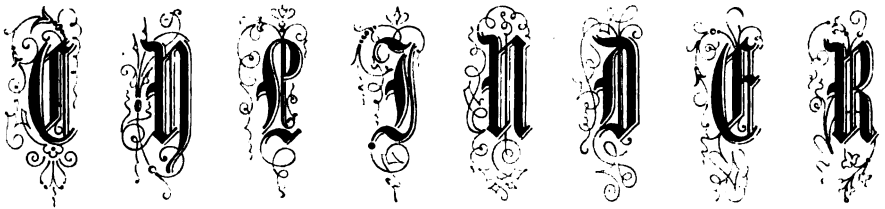

SERIES No. 55.

Single Letters, 30 cents; per set of 26 Letters, \$3.50.



SERIES No. 33.

Single Letters, 30 cents; per set of 26 Letters, \$3.50.



SERIES No. 32.

Single Letters, 30 cents; per set of 25 Letters, \$3.50.



ELECTROTYPE INITIALS.

SERIES No. 56.

Single Letters, 50 cents; per set of 24 Letters, \$6.00.

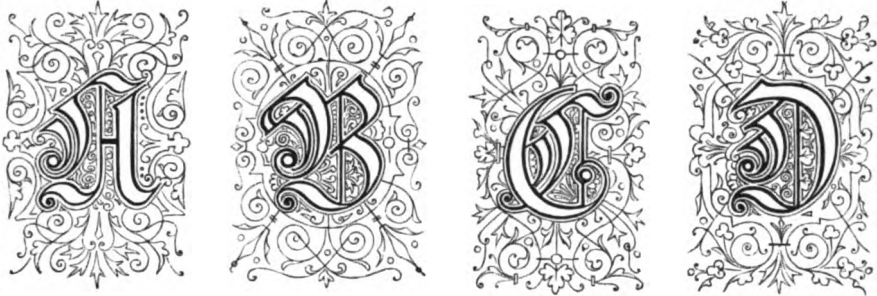

SERIES No. 57.

Single Letters, 50 cents; per set of 25 Letters, \$6.00.



SERIES No. 58.

Single Letters, 50 cents; per set of 24 Letters, \$6.00.



SERIES No. 59.

Single Letters, 40 cents; per set of 25 Letters, with Ornaments, \$4.50.

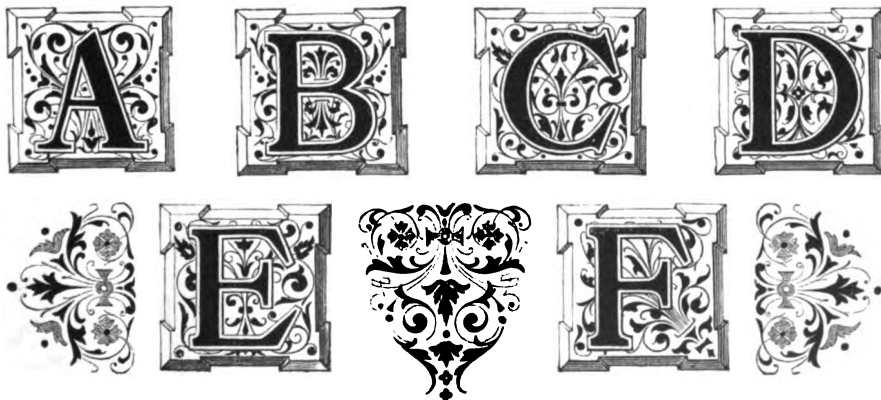

ORNAMENTAL INITIALS.

SERIES No. 69.

Single Letter, 90 cents; per set of 24 Letters, \$18.00.

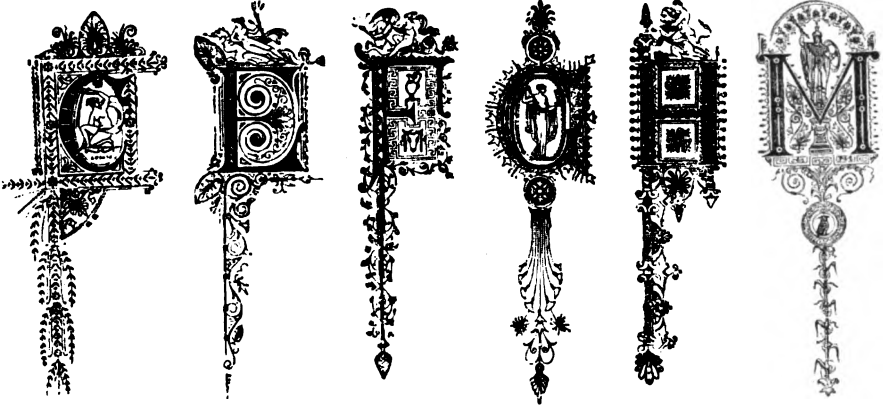

SERIES No. 70.

Single Letter, \$1.00; per set of 24 Letters, \$22.00.



ORNAMENTAL INITIALS.

SERIES No. 66.

Single Letter, 90 cents; per set of 26 Letters, \$18.00.

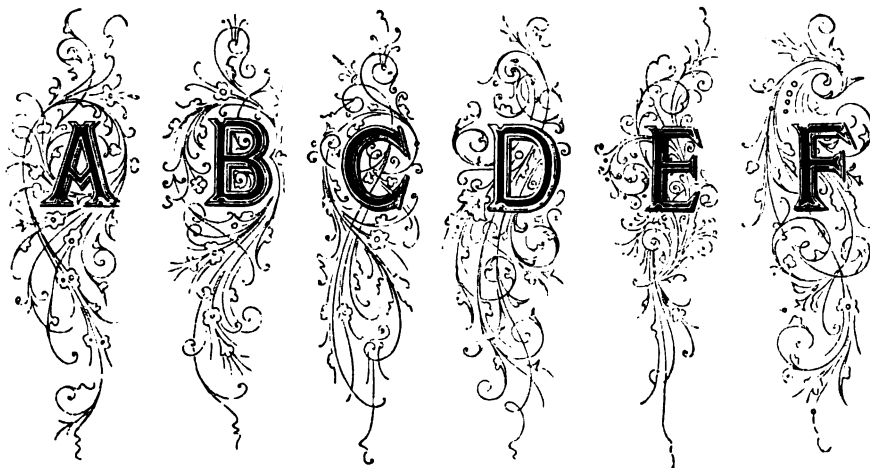

SERIES No. 67.

Single Letter, 90 cents; per set of 24 Letters, \$18.00.

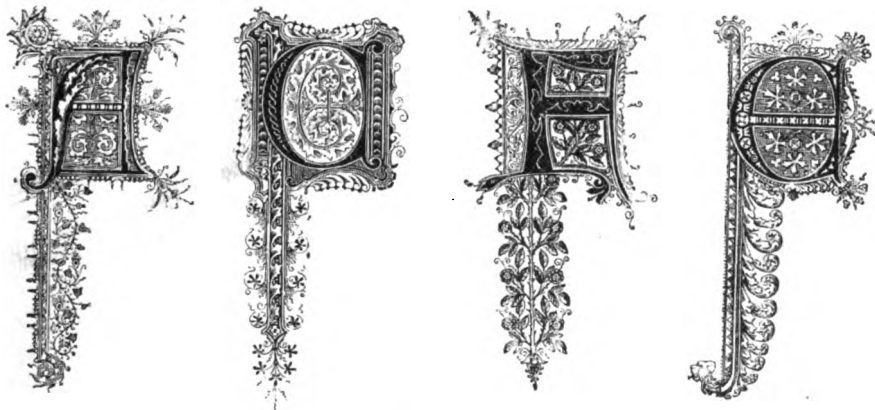

SERIES No. 68.

Single Letter, \$1.00; per set of 26 Letters, \$22.00.

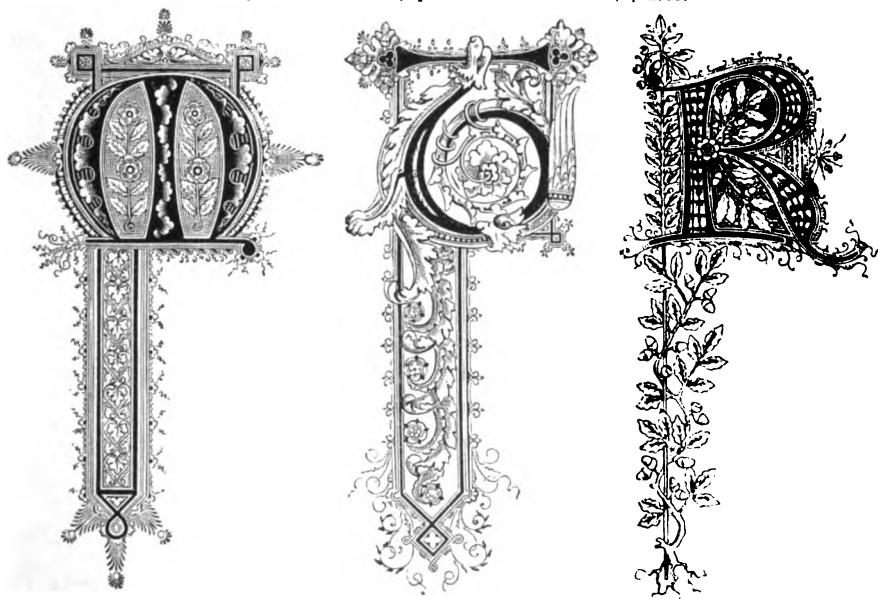

ELECTROTYPE INITIALS.

SERIES No. 60.

Single Letters, 25 cents; per set of 26 Letters, \$5.00.



SERIES No. 61.

Single Letters, 35 cents; per set of 26 Letters, \$6.00.



SERIES No. 62.

Single Letters, 50 cents; per set of 26 Letters, \$6.00.



SERIES No. 63.

Single Letters, 35 cents; per set of 26 Letters, \$6.00.



SERIES No. 64.

Single Letters, 50 cents; per set of 26 Letters, \$6.00.



SERIES No. 65.

Single Letters, 50 cents; per set of 26 Letters, \$6.00.



Monograms.

Price, 50 cents each.

Complete set, containing every combination of two letters except X and Y. No combinations of more than two characters are made.

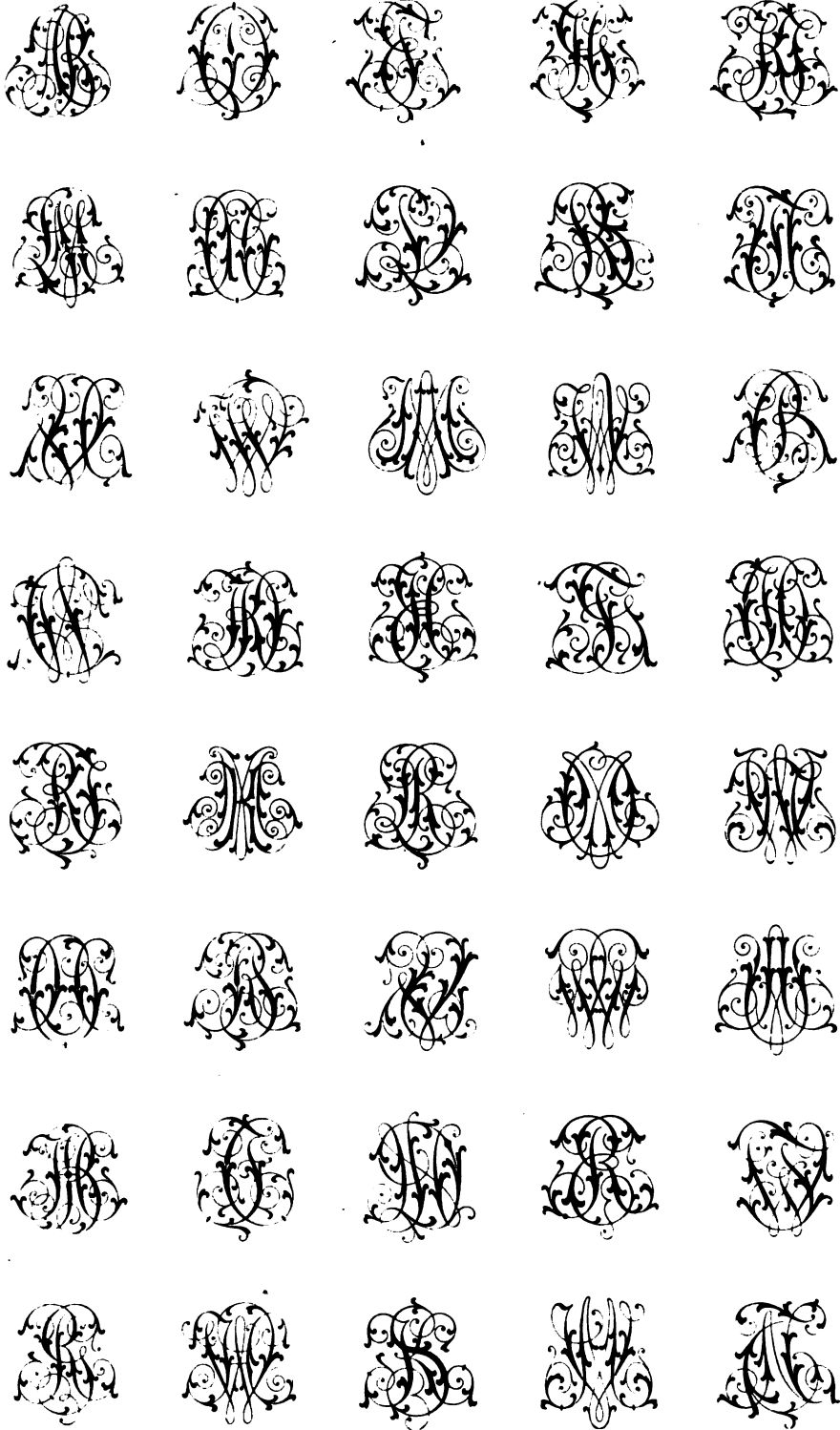

Newspaper Headings.

TWO-LINE GREAT PRIMER CONDENSED No. 1.

HURON REGISTER

TWO-LINE PARAGON CONDENSED No. 5.

SCRANTON REFORMER

FOUR-LINE PICA CONDENSED No. 5.

TRUE DEMOCRAT

TWO-LINE PARAGON CONDENSED No. 1.

HAMDEN LEDGER

FOUR-LINE PICA CONDENSED No. 1.

COURT RECORD

FOUR-LINE PICA CONDENSED LIGHT-FACE No. 2.

DALTON BLADE

SIX-LINE PICA CONDENSED LIGHT-FACE No. 4.

UNION TIMES

The average price of electrotyped headings from any type in any Specimen Book is \$2.50.
Special engraved heads made to order at prices according to style and size, from \$15.00 to \$100.00.

Newspaper Headings.

FOUR-LINE PICA No. 3.

SELMA GUIDE

FOUR-LINE PICA LIGHT-FACE No. 2.

HOME NEWS

FIVE-LINE PICA No. 1.

REGISTER

SIX-LINE PICA LIGHT-FACE No. 2.

TRIBUNE

SIX-LINE PICA No. 1.

BUGLE

SIX-LINE PICA ITALIC.

TIMES

The average price of electrotyped heads from any type in any Specimen Book is \$2.50.

Special engraved heads made to order at prices according to style and size, from \$15.00 to \$100.00.

Newspaper Headings.

FOUR-LINE PICA OLD STYLE.

THE MONITOR

FOUR-LINE PICA OLD STYLE WITH FIVE-LINE PICA INITIALS.

HURON NEWS

FIVE-LINE PICA OLD STYLE.

REPORTER
Home Journal

FIVE-LINE PICA OLD STYLE WITH SIX-LINE PICA INITIALS.

MORNING

SIX-LINE PICA OLD STYLE.

EDITION
Peoria Item

The average price of electrotyped heads from any type in any Specimen Book is \$2.50.
Special engraved heads made to order at prices according to style and size, from \$15.00 to \$100.00.

Newspaper Headings.

SIX-LINE PICA SLOPING BLACK.

Weekly Herald

Also EIGHT-LINE PICA SLOPING BLACK.

SEVEN-LINE PICA LONDON TEXT SHADED.

Penny Paper

NINE-LINE PICA LONDON TEXT SHADED.

The News

SIX-LINE PICA BLACK CONDENSED NO. 3.

Art Journal

EIGHT-LINE PICA MODERN TEXT.

Columbian.

Also TEN-LINE PICA MODERN TEXT.

The average price of electrotyped headings from any type in any Specimen Book is \$2.50.
Special engraved heads made to order at prices according to style and size, from \$15.00 to \$100.00.

Newspaper Headings.

SIX-LINE PICA FANCY TEXT.

Dalton Times

FIVE-LINE PICA BLACK ORNAMENTED.

New Advocate

SIX-LINE PICA BLACK OPEN.

Daily Gazette

SEVEN-LINE PICA CONDENSED OPEN BLACK.

Free Press

SEVEN-LINE PICA MODERN TEXT DOUBLE SHADED.

Oxford Acme

Also EIGHT and TEN-LINE PICA MODERN TEXT DOUBLE SHADED.

SEVEN-LINE PICA MODERN TEXT ORNAMENTED NO. 1.

Daily Review

Also EIGHT and TEN-LINE PICA MODERN TEXT ORNAMENTED NO. 1.

The average price of electrotyped headings from any type in any Specimen Book is \$2.50.
Special engraved heads made to order at prices according to style and size, from \$15.00 to \$100.00.

Newspaper Headings.

SIX-LINE PICA INITIAL TEXT.

The Courier

EIGHT-LINE PICA BLACK EXTRA CONDENSED.

Boston Herald

SIX-LINE PICA BISMARCK BLACK.

Alton Globe

EIGHT-LINE PICA BISMARCK BLACK.

Recorder

TEN-LINE PICA BISMARCK BLACK.

Season

The average price of electrotyped headings from any type in any Specimen Book is \$2.50.
Special engraved heads made to order at prices according to style and size, from \$15.00 to \$100.00.

UNSATISFACTORY ANSWERS TO CORRESPONDENTS.

THE questions quoted below—and similar ones asked in many letters every day—are hardly susceptible of satisfactory replies without further correspondence and explanations, at which patrons often become impatient. For instance :

Have you any Second-Hand Presses?

To this question we can but give a wordy affirmative, while, if our patron was more communicative, and told us size, kind, price and purpose of the article sought, we might serve him at once.

On what Time will you Sell \$2,000 Worth of Goods?

We should know what this bill of goods consists of; should, in fact, have a copy of proposed order; should know the terms our customer wants, and, if he be unknown to us, his financial responsibility, or what security he has to offer us. In fact, he should state to us what goods, what time, how good—can't reply to the one point he makes until posted on the three points we make.

What Discount do you Make for Cash?

On some goods nothing; on others a great deal; all depends on what you buy, and how much of it.

List of Goods Wanted

Should always accompany the above question, as well as the preceding one.

We have said enough, if we can only get you to read it, to save you many vexatious delays. See that we are posted on the three points above mentioned, and write fully and specifically for any thing whatever, in the press or type line, to the

CINCINNATI TYPE FOUNDRY.



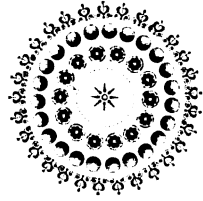

ORIGINAL BORDERS.

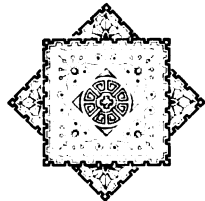

COMBINATION BORDERS.

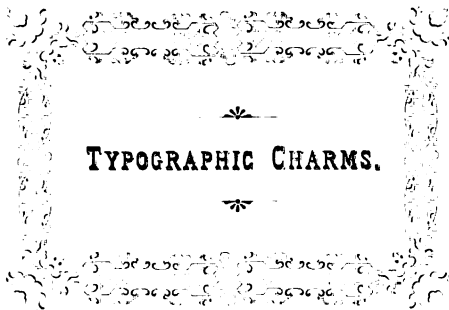
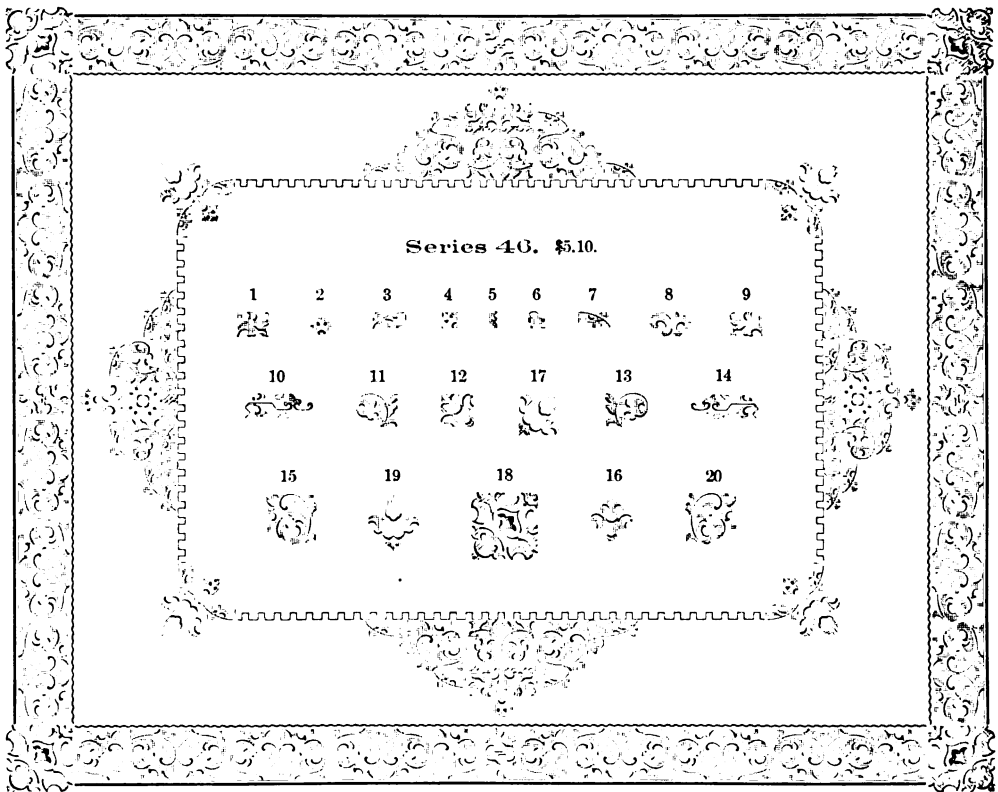

COMBINATION BORDERS.

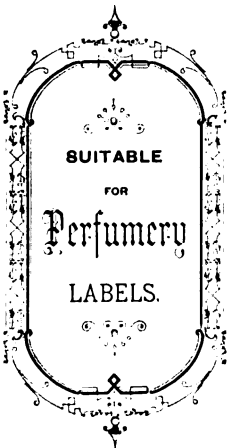
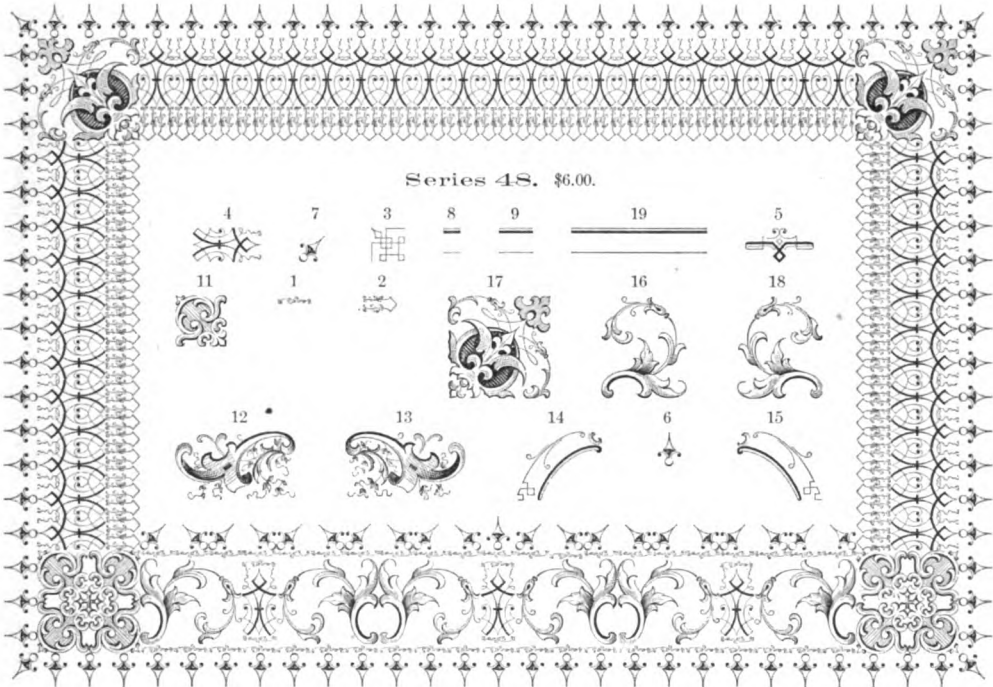
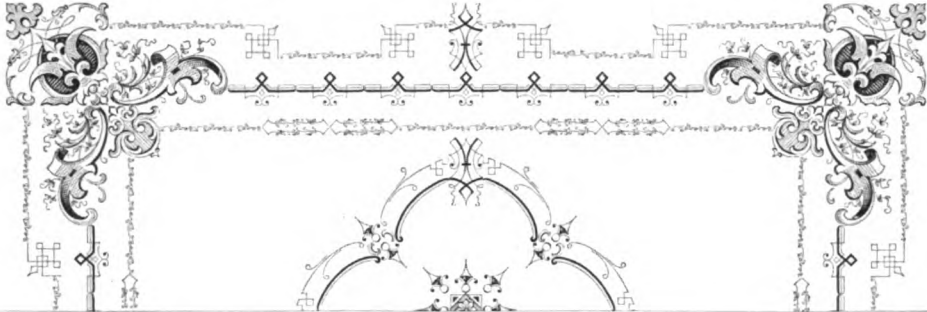

COMBINATION BORDERS.

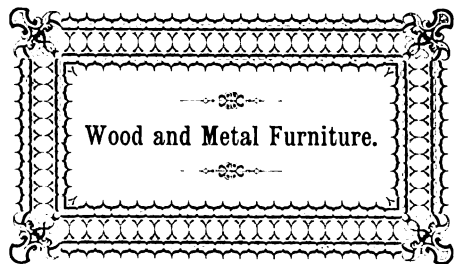
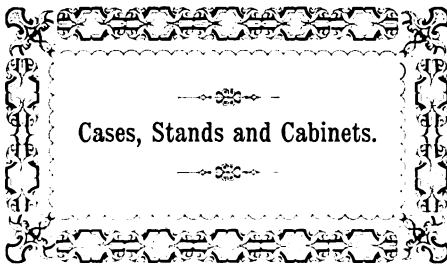
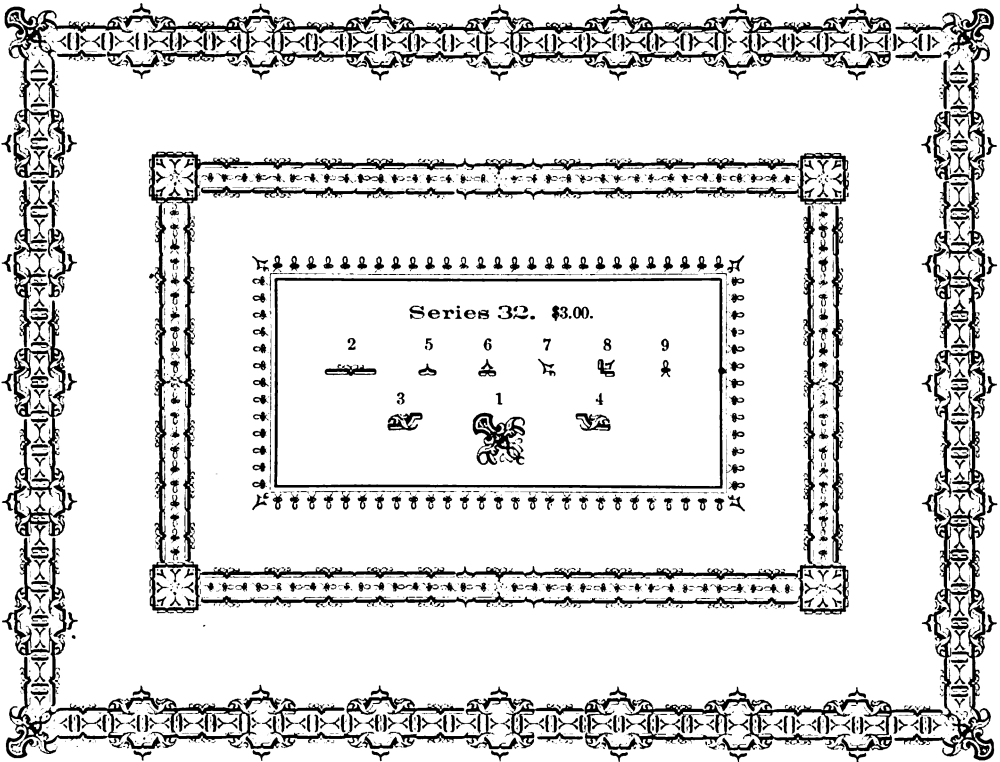

COMBINATION BORDERS.

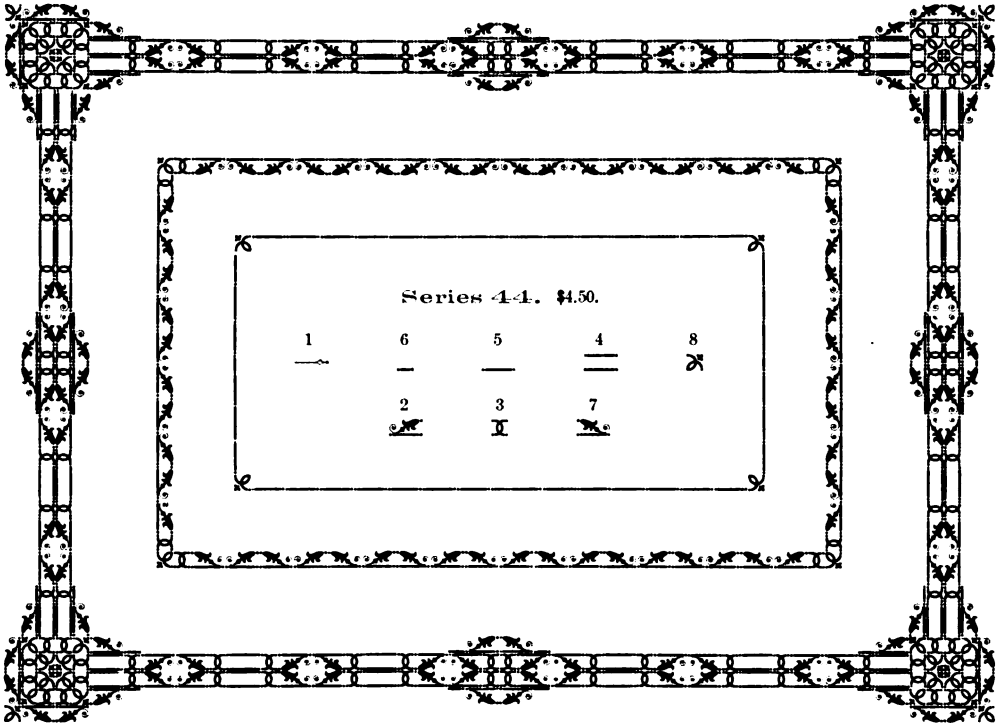
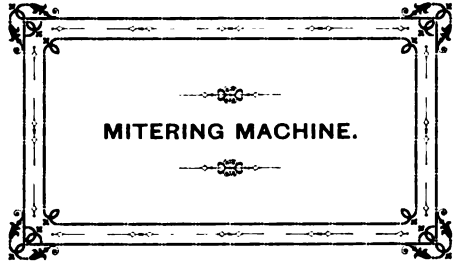
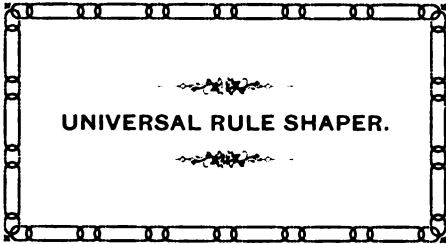

COMBINATION BORDERS.

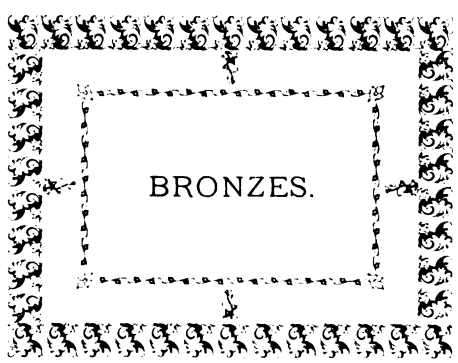
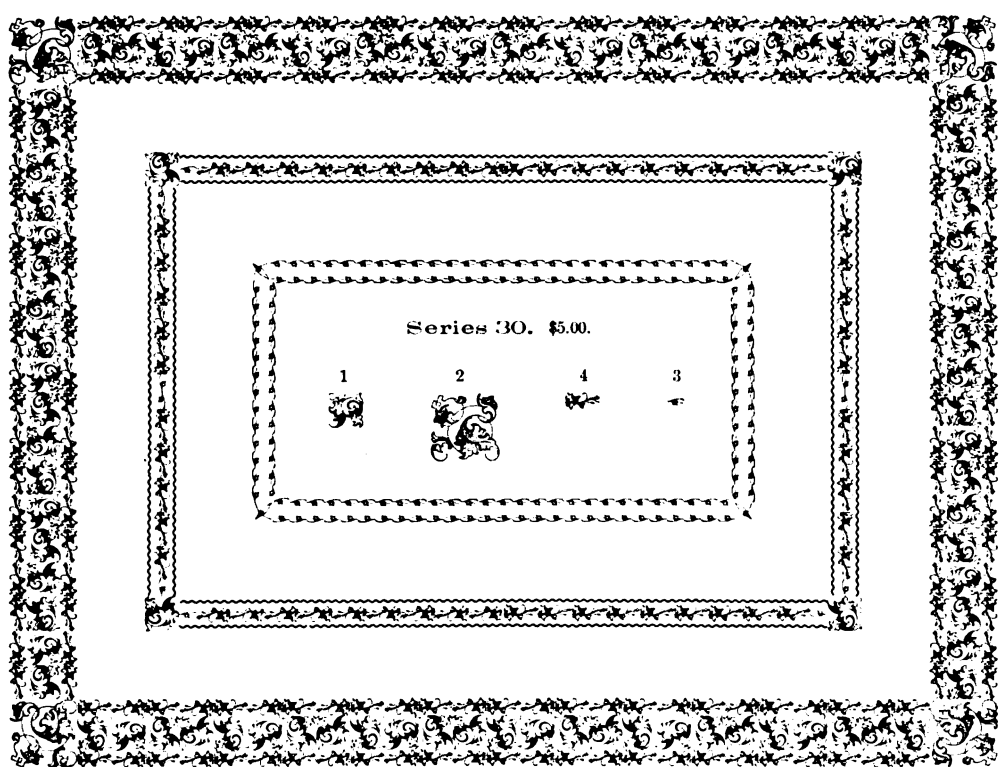
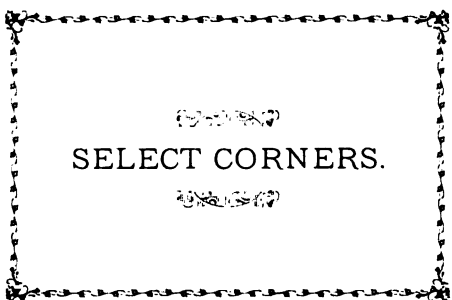

COMBINATION BORDERS.

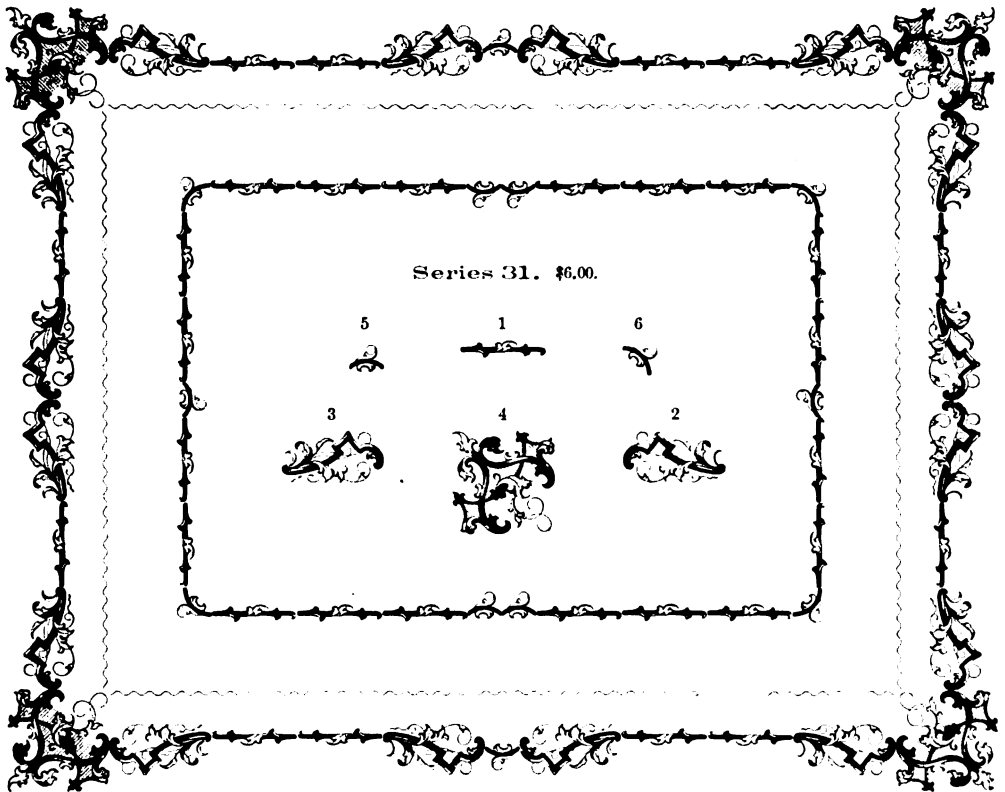
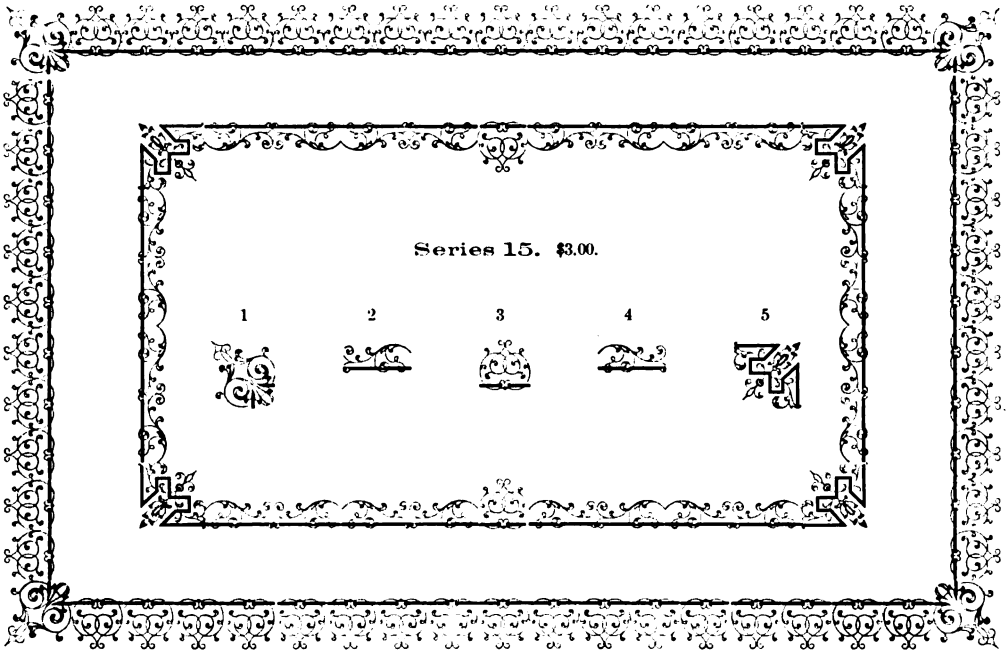

COMBINATION BORDERS.

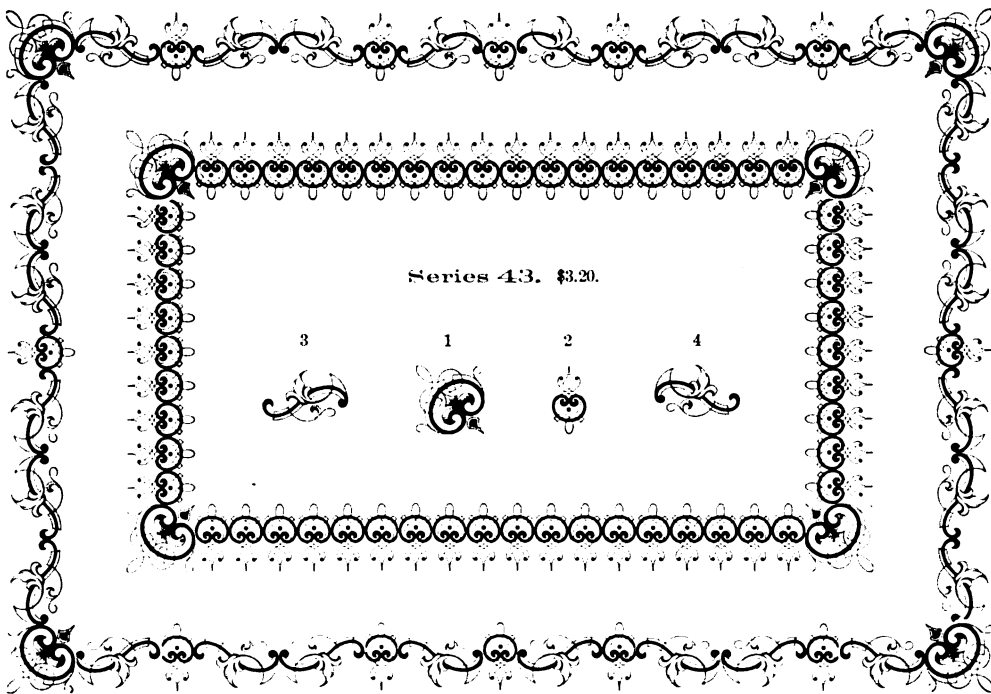
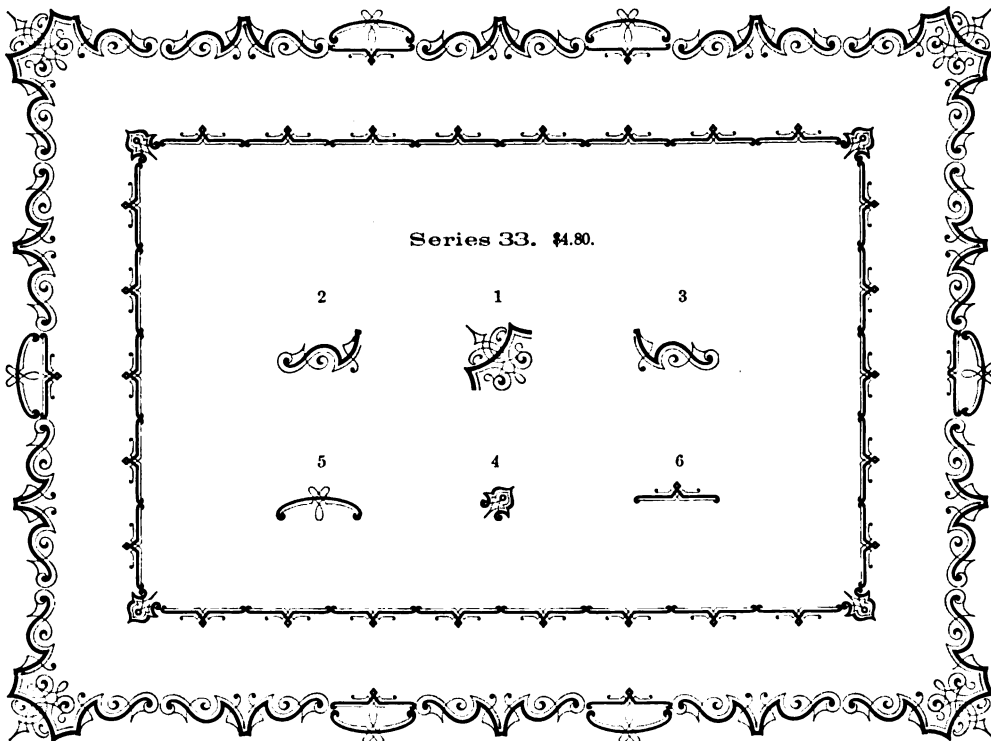

COMBINATION BORDERS.



Series 22. \$6.00.

1	2	3	4	5	6
10	7	8	9	11	
12	16	13	14	15	



HALF MINIONETTE BORDERS.

Fonts of 10 feet each, \$2.25.

HALF MINIONETTE BORDER No. 1.



HALF MINIONETTE BORDER No. 3.



HALF MINIONETTE BORDER No. 5.

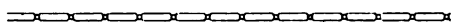

HALF MINIONETTE BORDER No. 7.



HALF MINIONETTE BORDER No. 2.



HALF MINIONETTE BORDER No. 4.



HALF MINIONETTE BORDER No. 6.



HALF MINIONETTE BORDER No. 8.



MINIONETTE BORDERS.

Fonts of 10 feet each, \$2.90.

MINIONETTE BORDER No. 15.



MINIONETTE BORDER No. 30.

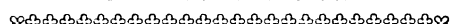

MINIONETTE BORDER No. 35.



MINIONETTE BORDER No. 25.



MINIONETTE BORDER No. 13.



MINIONETTE BORDER No. 22.



MINIONETTE BORDER No. 33.

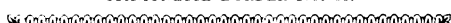

MINIONETTE BORDER No. 32.



MINIONETTE BORDER No. 12.



MINIONETTE BORDER No. 39.



MINIONETTE BORDER No. 37.



MINIONETTE BORDER No. 16.



MINIONETTE BORDER No. 31.

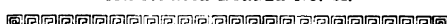

MINIONETTE BORDER No. 17.

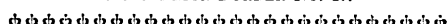

MINIONETTE BORDER No. 21.



MINIONETTE BORDER No. 14.



MINIONETTE BORDER No. 23.



MINIONETTE BORDER No. 38.



MINIONETTE BORDER No. 20.

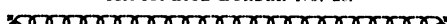

MINIONETTE BORDER No. 11.



MINIONETTE BORDER No. 34.



MINIONETTE BORDER No. 18.



MINIONETTE AND ONE-HALF BORDERS.

Fonts of 10 feet each, \$3.10.

MINIONETTE AND ONE-HALF BOR. No. 1.

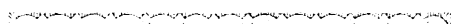

MINIONETTE AND ONE-HALF BOR. No. 2.



TWO-LINE MINIONETTE BORDERS.

Fonts of 10 feet each, \$3.50.

TWO-LINE MINIONETTE BORDER No. 15.



Tint for TWO-LINE MINIONETTE BORDER No. 15.

TWO-LINE MINIONETTE BORDERS.

Fonts of 10 feet each, \$3.50.

TWO-LINE MINIONETTE BORDER No. 18.

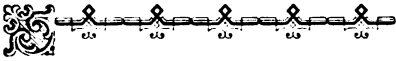

TWO-LINE MINIONETTE BORDER No. 8.

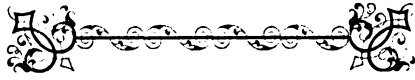

TWO-LINE MINIONETTE BORDER No. 31.



TWO-LINE MINIONETTE BORDER No. 30.



TWO-LINE MINIONETTE BORDER No. 27.



TWO-LINE MINIONETTE BORDER No. 29.



TWO-LINE MINIONETTE BORDER No. 25.



TWO-LINE MINIONETTE BORDER No. 26.



TWO-LINE MINIONETTE BORDER No. 36.



TWO-LINE MINIONETTE BORDER No. 38.



TWO-LINE MINIONETTE BORDER No. 32.



TWO-LINE MINIONETTE BORDER No. 28.



TWO-LINE MINIONETTE BORDER No. 33.



TWO-LINE MINIONETTE BORDER No. 35.

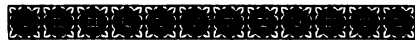

TWO-LINE MINIONETTE BORDER No. 37.



TWO-LINE MINIONETTE BORDER No. 34.



THREE-LINE MINIONETTE BORDERS.

Fonts of 10 feet each, \$4.85.

THREE-LINE MINIONETTE BORDER No. 6.



THREE-LINE MINIONETTE BORDER No. 7.



THREE-LINE MINIONETTE BORDER No. 5.



THREE-LINE MINIONETTE BORDER No. 1.



THREE-LINE MINIONETTE BORDER No. 2.



THREE-LINE MINIONETTE BORDER No. 3.



THREE-LINE MINIONETTE BORDER No. 4.



THREE, FOUR AND FIVE-LINE MINIONETTE BORDERS.

FIVE-LINE MINIONETTE BORDER No. 1. 5 feet, \$4.00.



THREE-LINE MINIONETTE BORDER No. 9. 10 feet, \$4.85.



FOUR-LINE MINIONETTE BORDER No. 7. 10 feet, \$6.65.



FOUR-LINE MINIONETTE BORDER No. 8. 10 feet, \$6.65.



FOUR-LINE MINIONETTE BORDER No. 9. 10 feet, \$6.65.



FOUR-LINE MINIONETTE BORDER No. 3. 10 feet, \$6.65.



FOUR-LINE MINIONETTE BORDER No. 4. 10 feet, \$6.65.



FOUR-LINE MINIONETTE BORDER No. 6. 10 feet, \$6.65 (WITH THREE TINTS, \$26.60.)



FOUR-LINE MINIONETTE BORDER No. 5. 10 feet, \$6.65.



FOUR-LINE MINIONETTE BORDER No. 10. 10 feet, \$6.65.



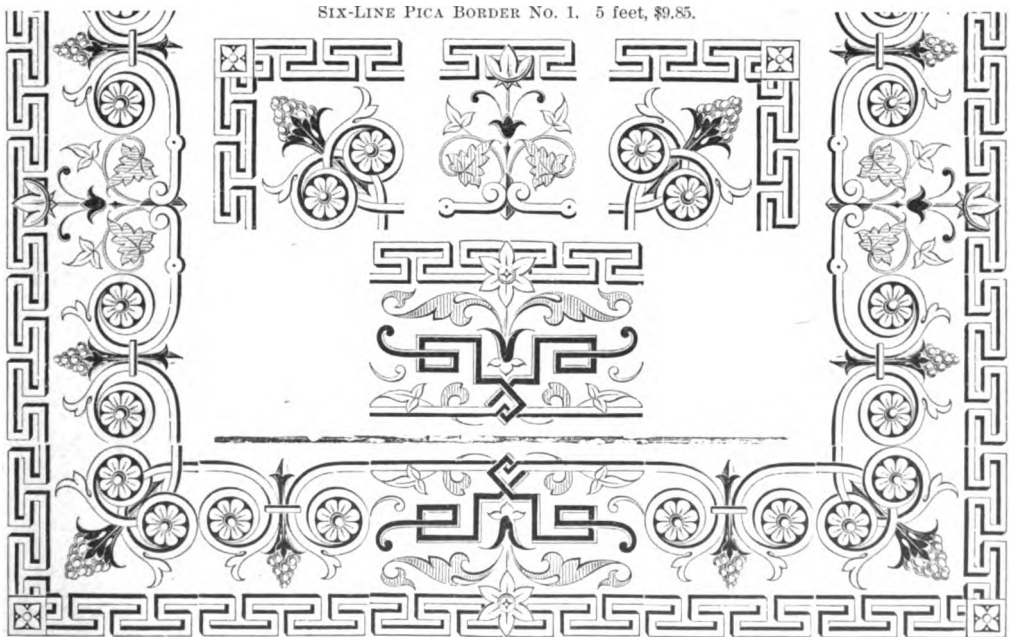
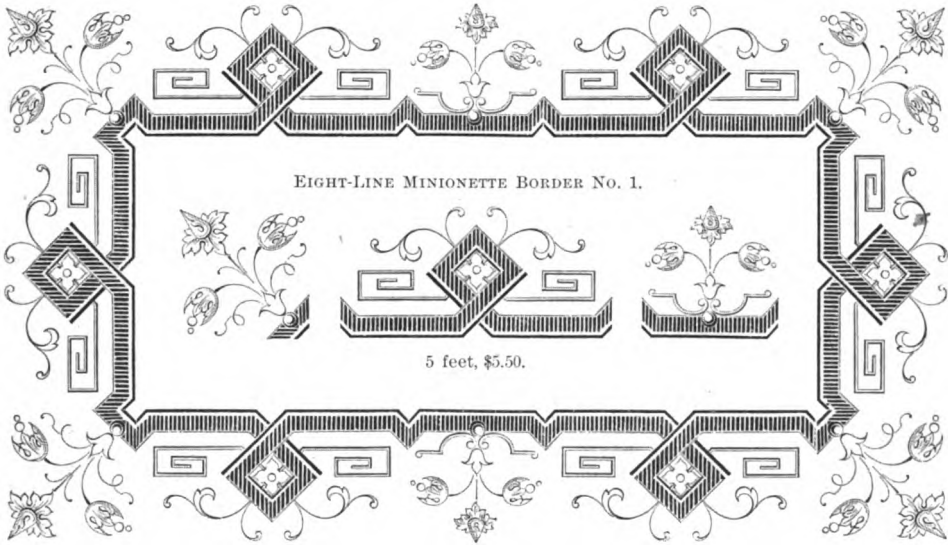
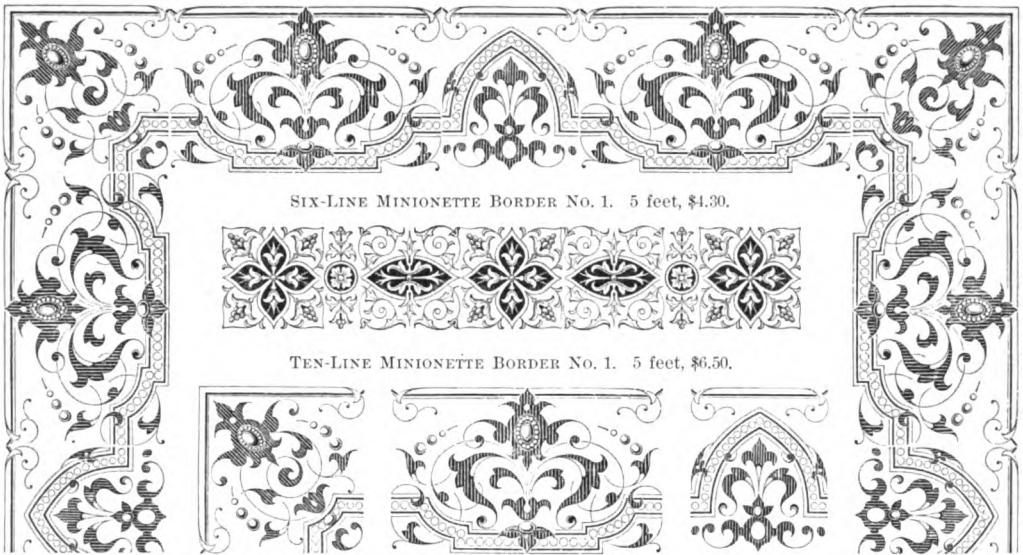

HALF NONPAREIL BORDERS.

PATENT APPLIED FOR.

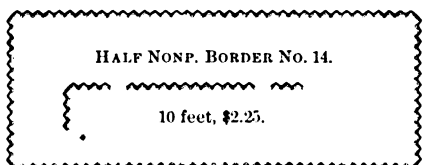
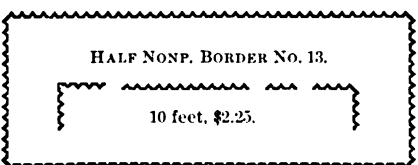
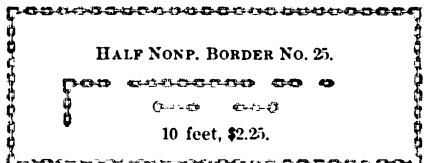
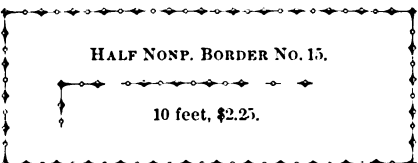
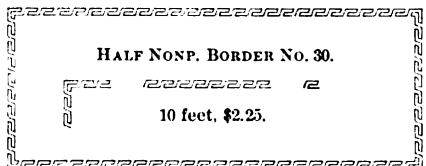
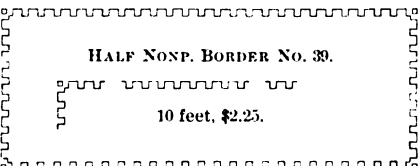
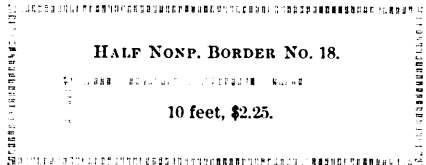
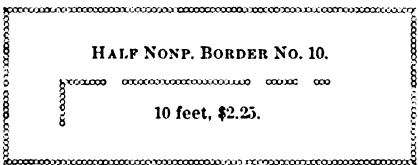
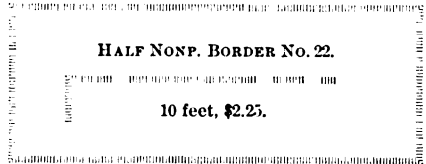
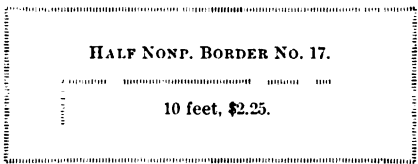
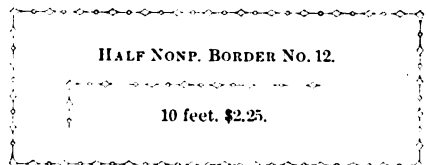
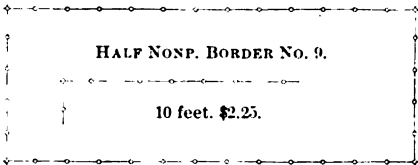
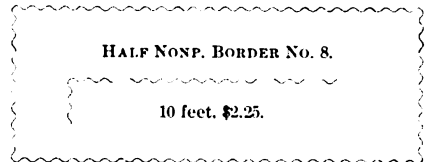
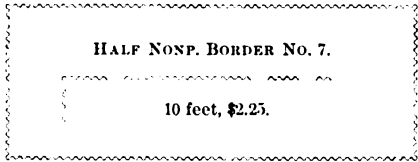
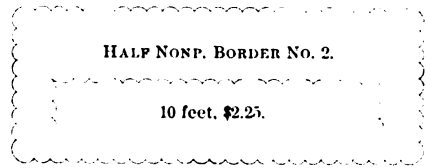
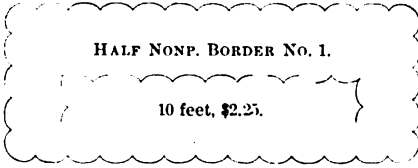

HALF NONPAREIL BORDERS.

PATENT APPLIED FOR.

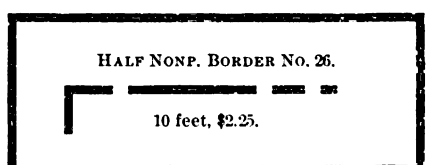
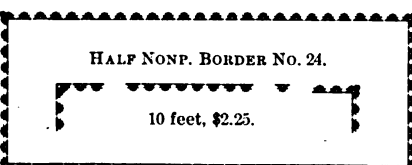
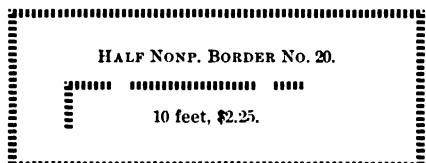
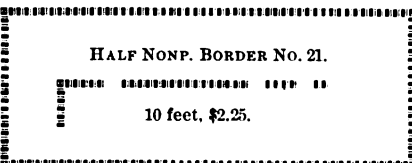
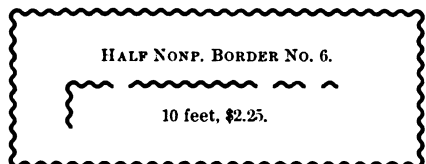
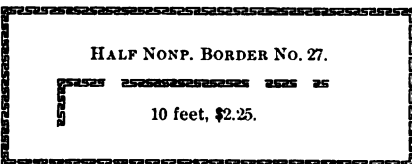
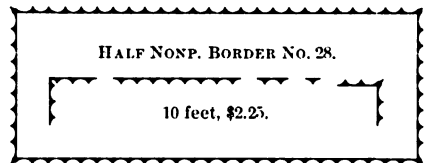
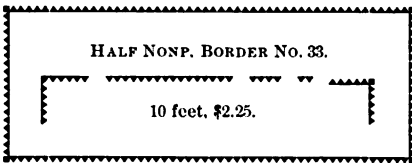
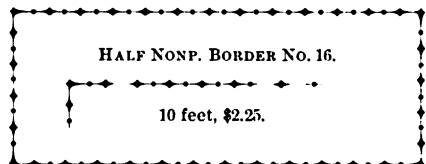
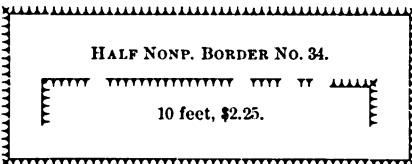
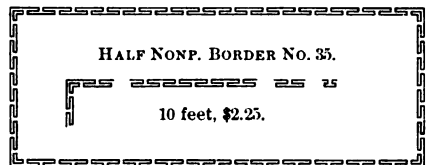
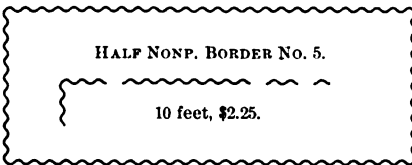
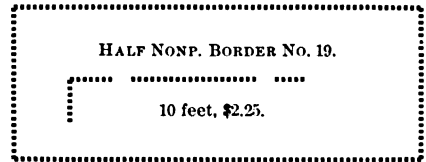
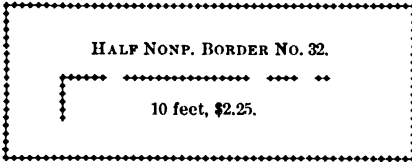
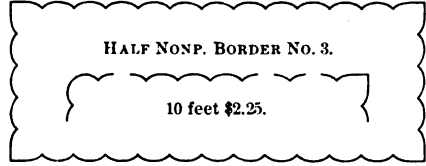
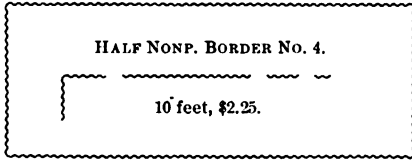

HALF NONPAREIL BORDERS.

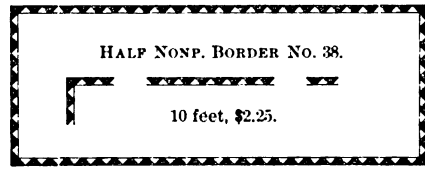
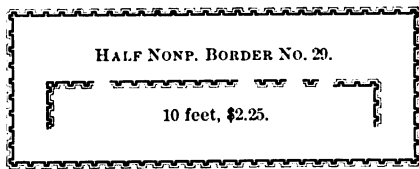
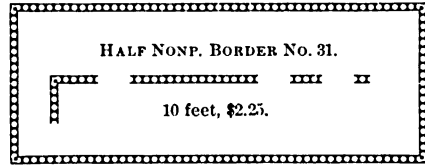
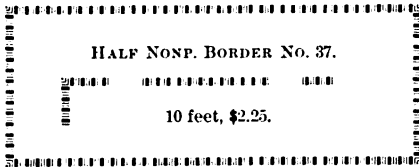
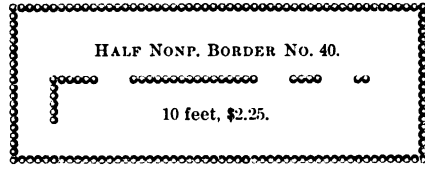
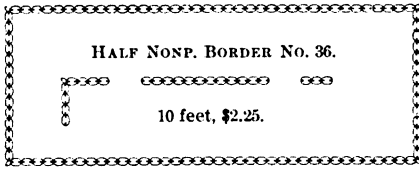

NONPAREIL BORDERS.

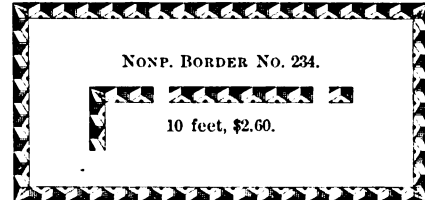
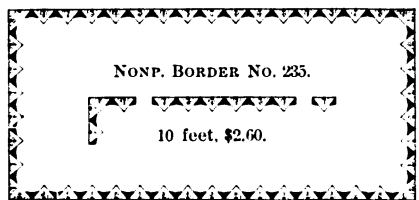
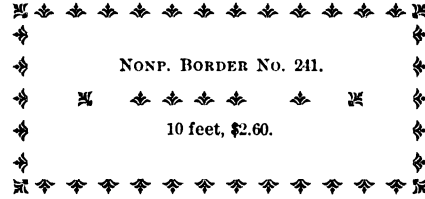
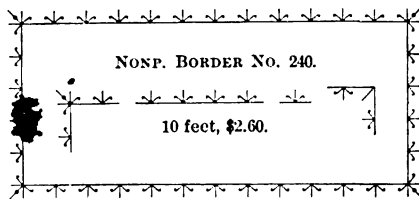
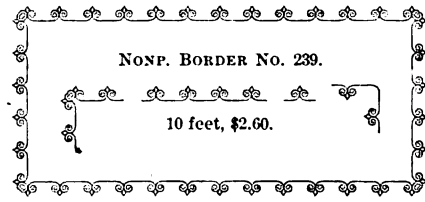
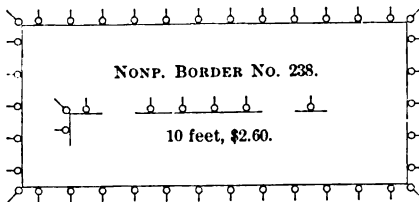

NONPAREIL BORDERS.

PATENT APPLIED FOR.

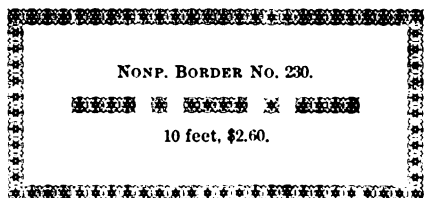
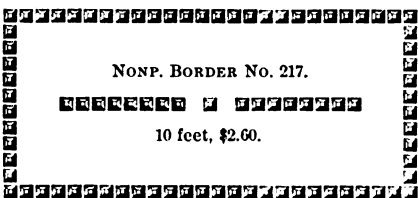
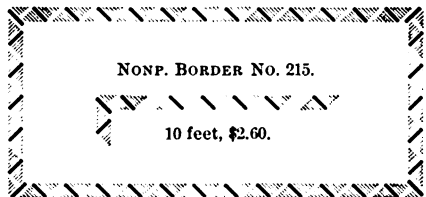
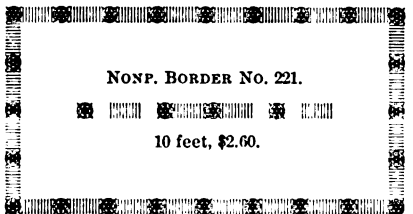
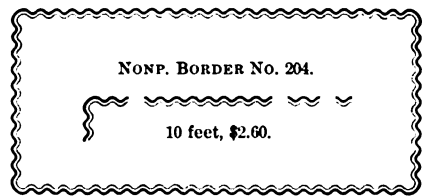
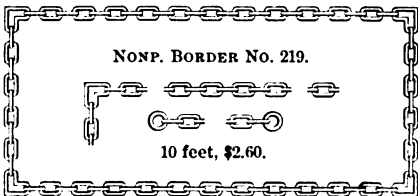
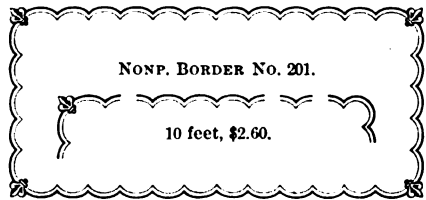
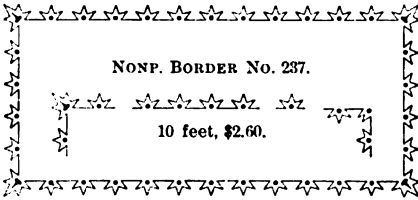
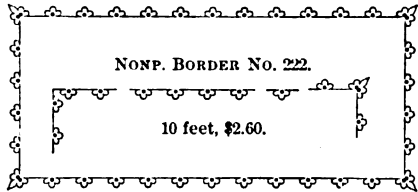
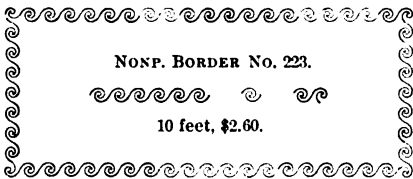
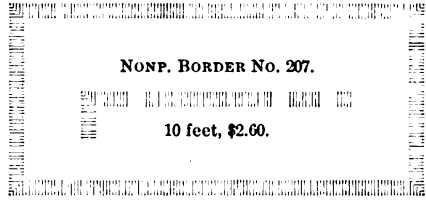
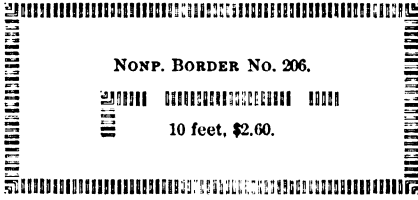

NONPAREIL BORDERS.

PATENT APPLIED FOR.

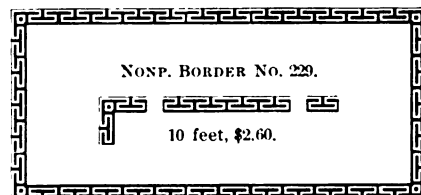
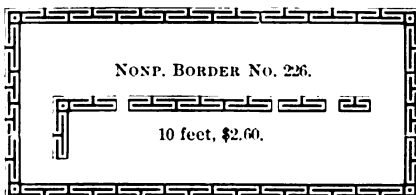
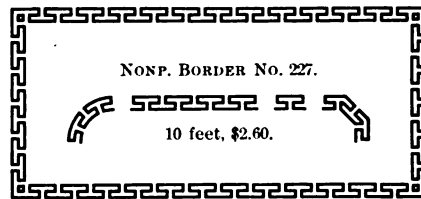
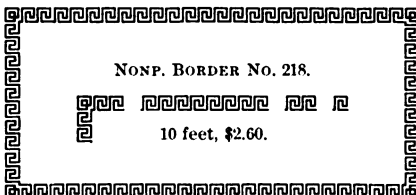
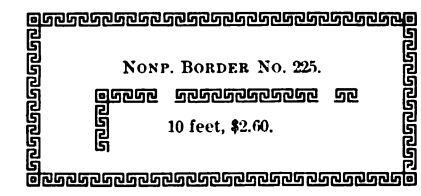
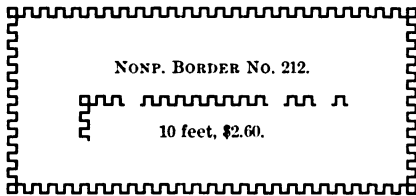
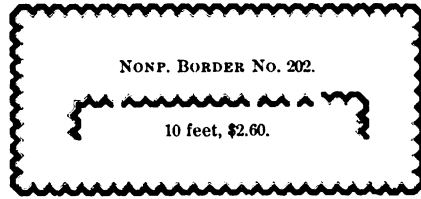
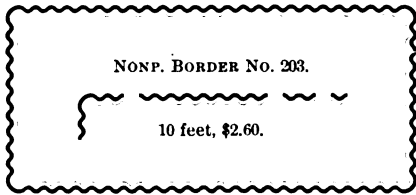
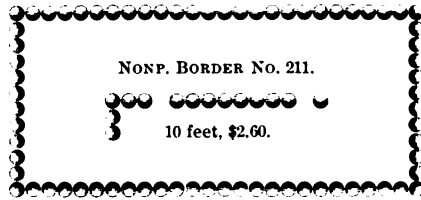
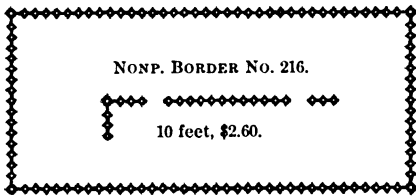
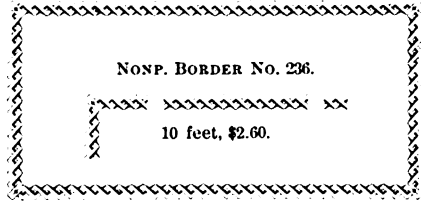
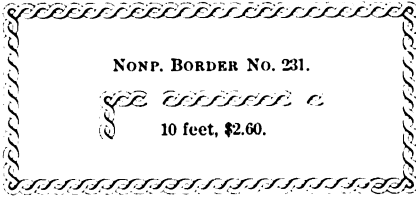

NONPAREIL BORDERS.

PATENT APPLIED FOR.

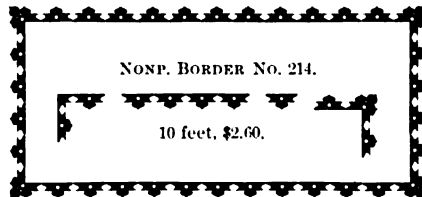
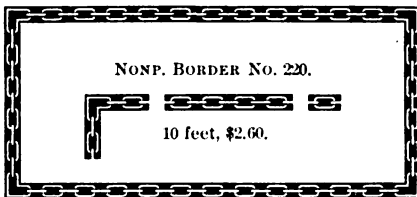
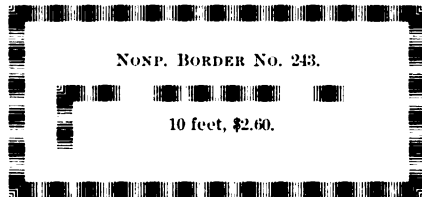
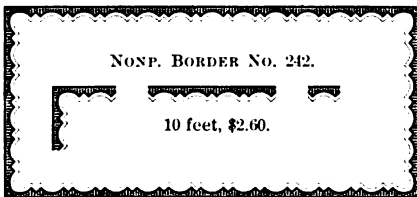
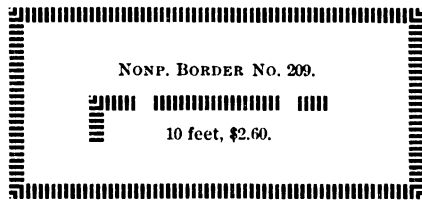
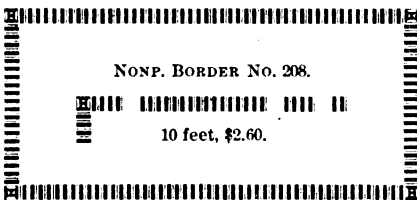
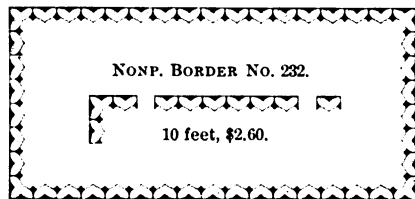
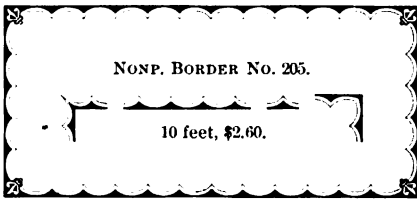
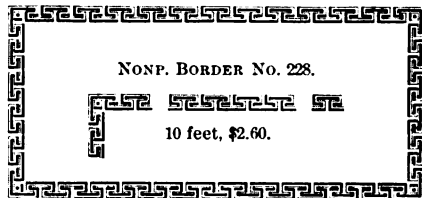
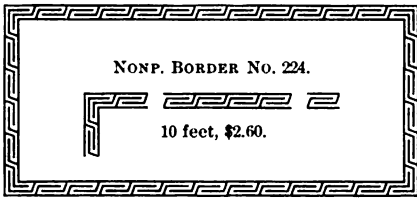
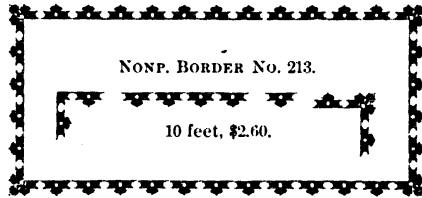
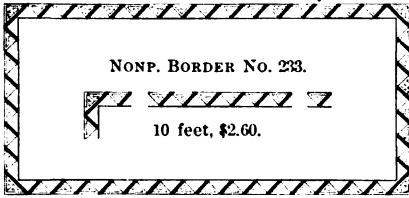

NONPAREIL AND ONE-HALF BORDERS.

PATENT APPLIED FOR.

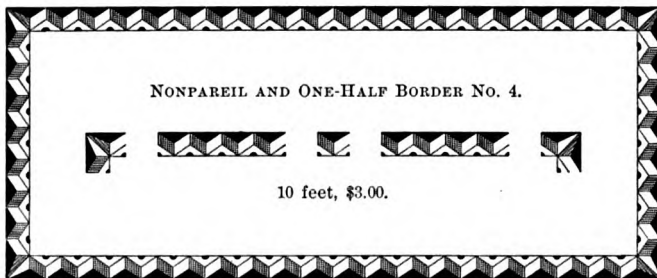
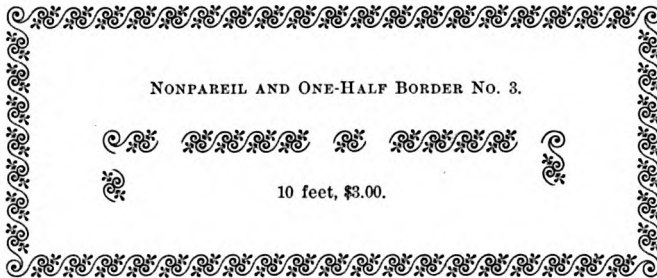
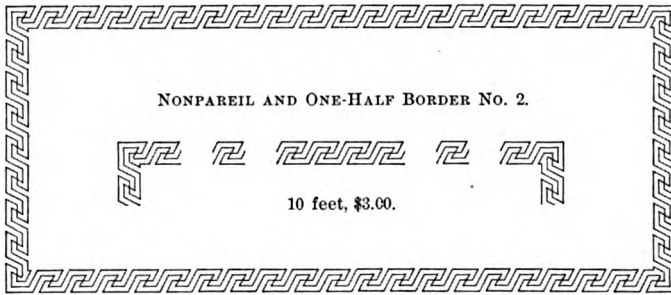

NONPAREIL AND ONE-HALF BORDERS.

PATENT APPLIED FOR.

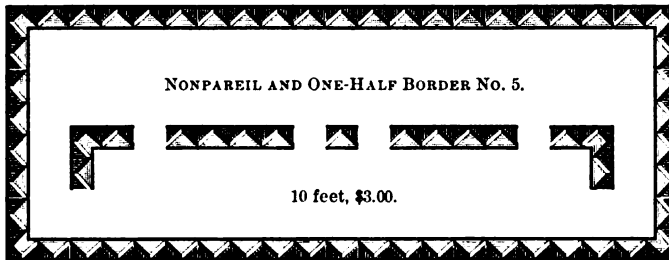
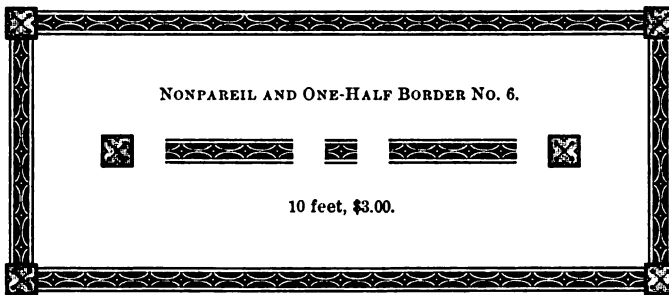
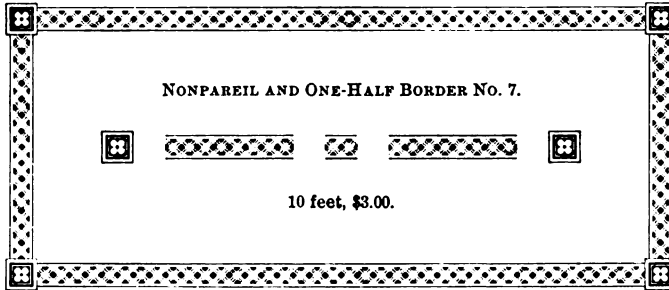

PICA BORDERS.

PATENT APPLIED FOR.

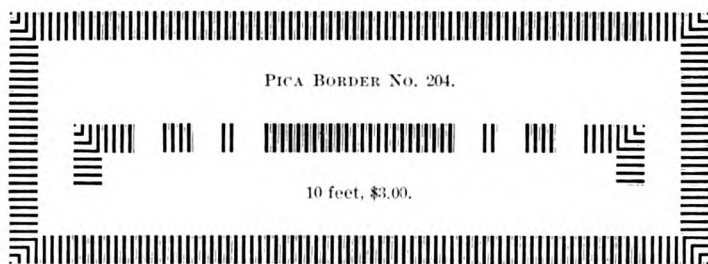
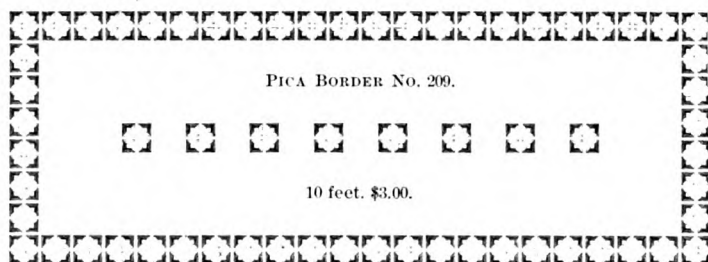
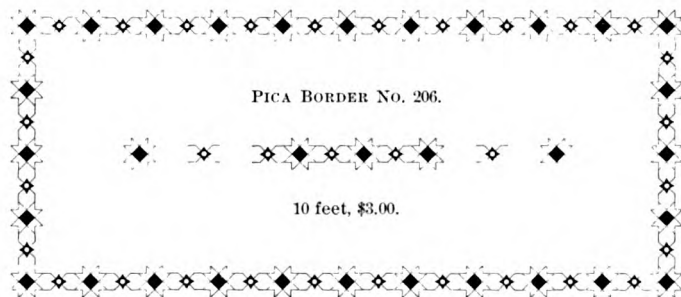
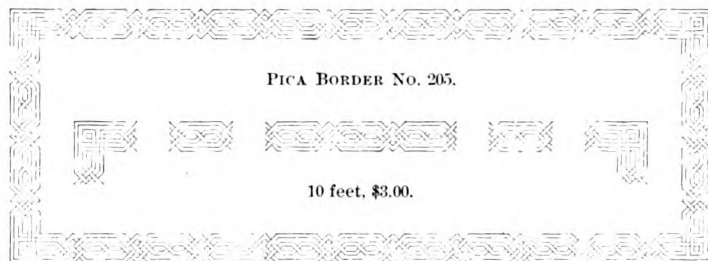

142 Cincinnati Type Foundry, 201 Vine St.

PICA BORDERS.

PATENT APPLIED FOR.

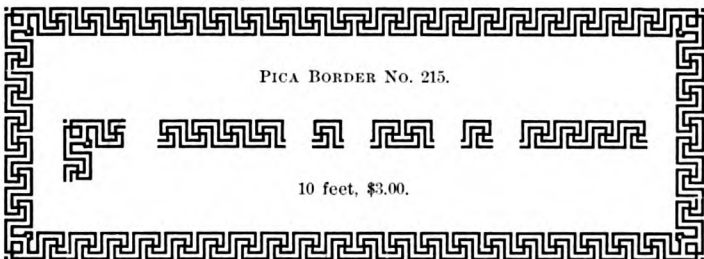
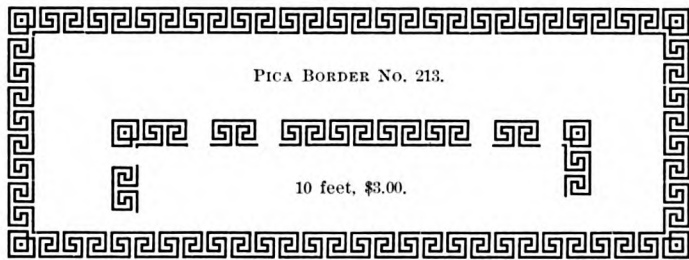
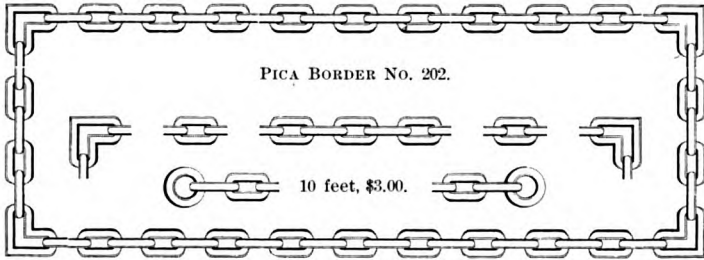
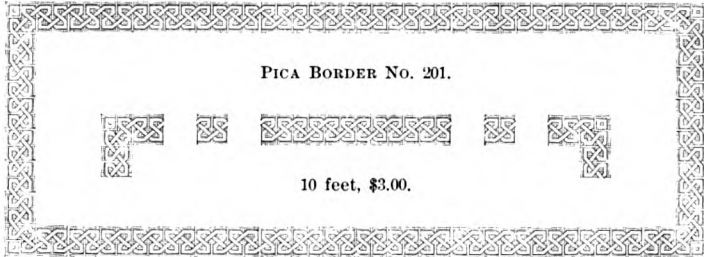

PICA BORDERS.

PATENT APPLIED FOR.

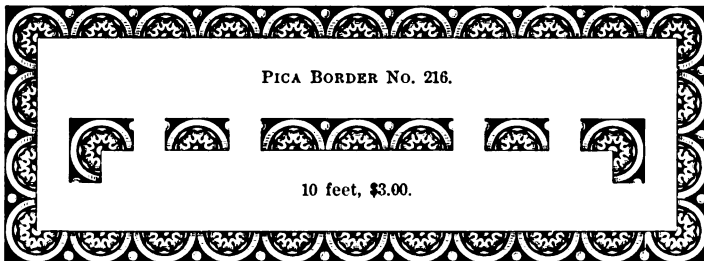
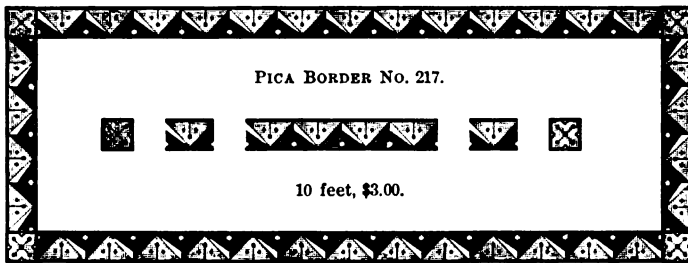
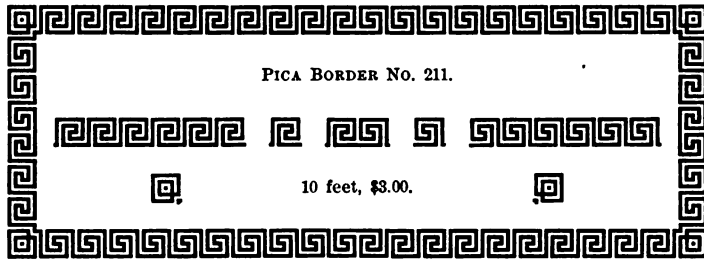
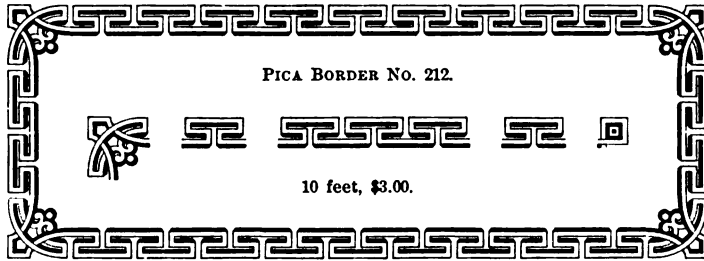

PICA BORDERS.

PATENT APPLIED FOR.

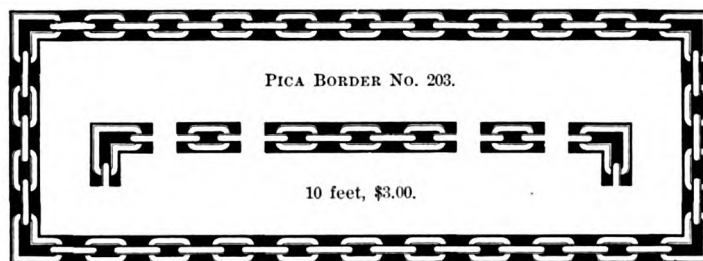
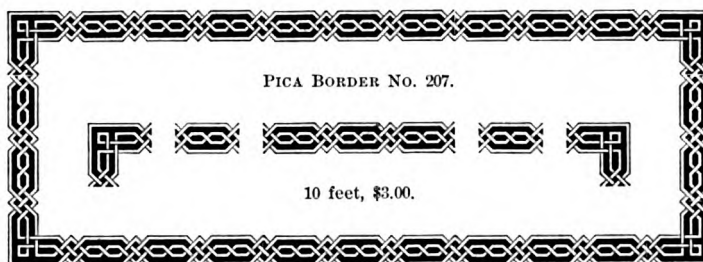
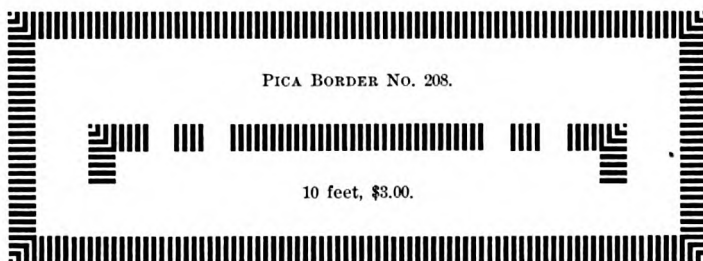
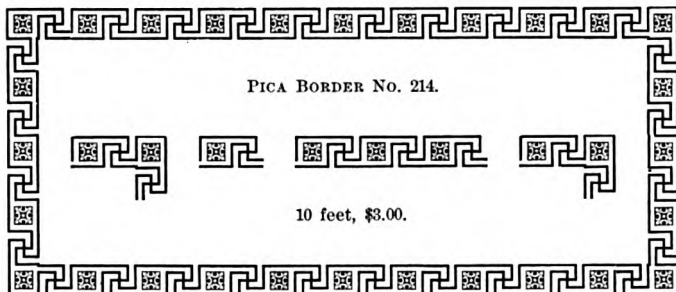

LARGER BORDERS.

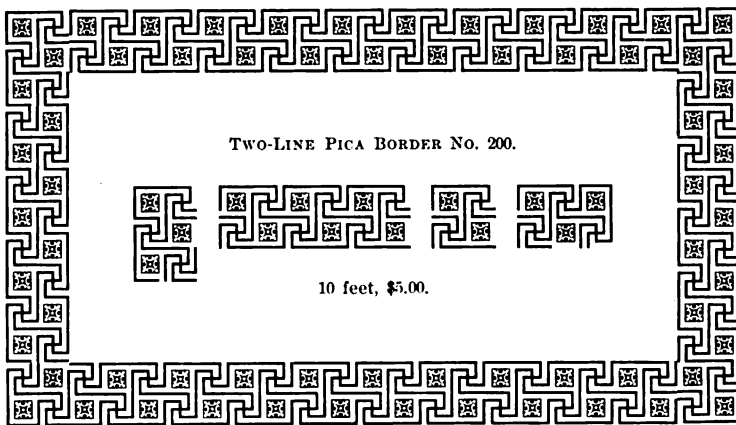
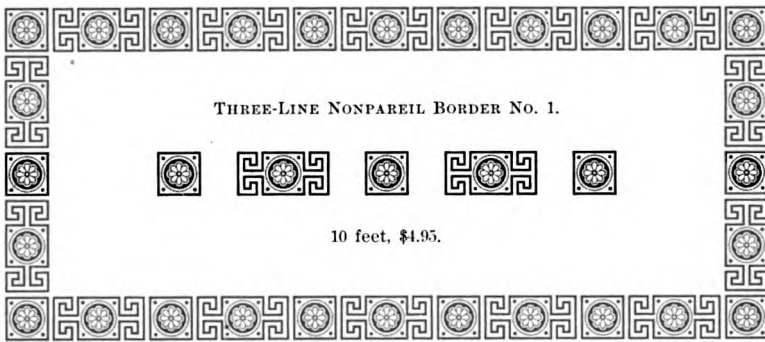
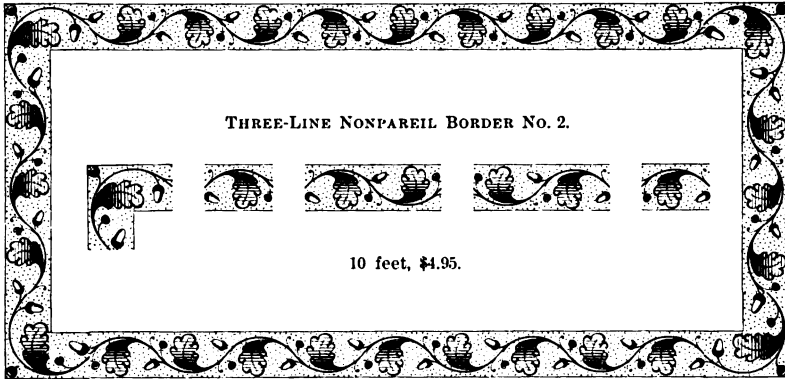

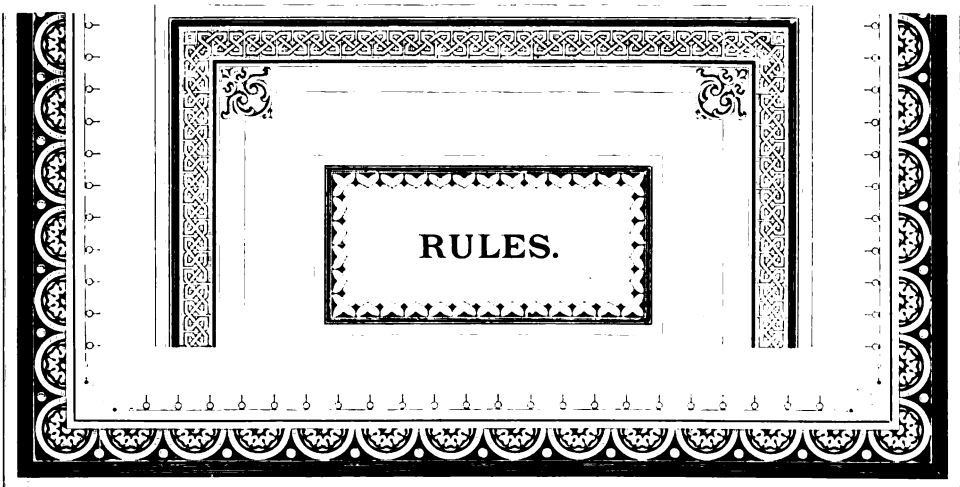
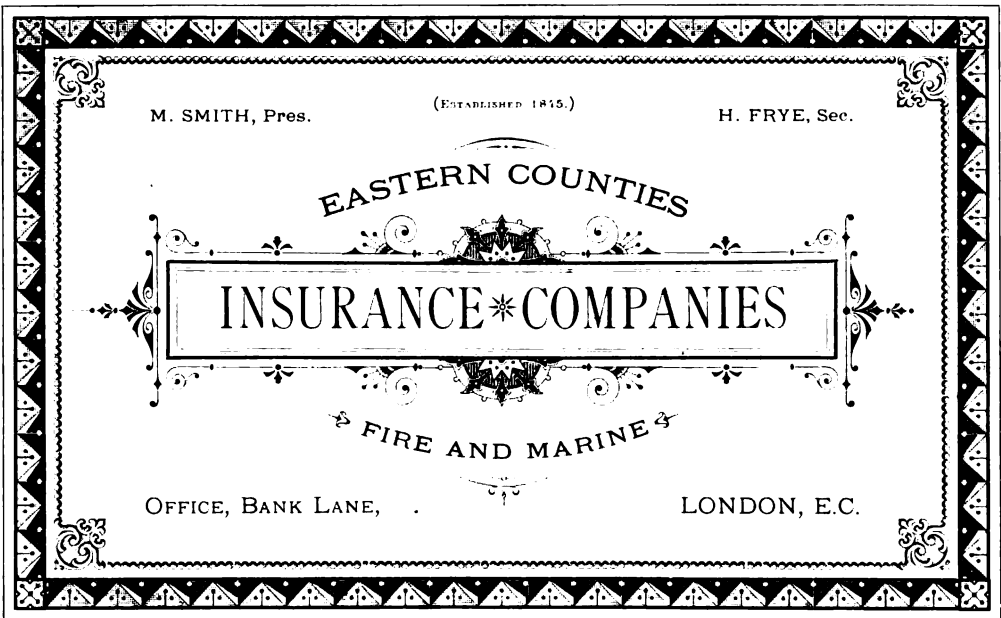
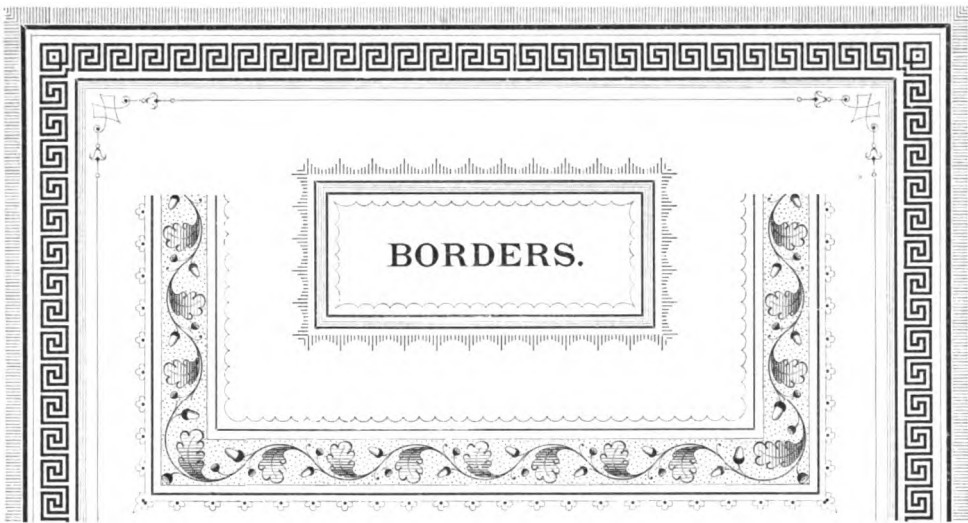

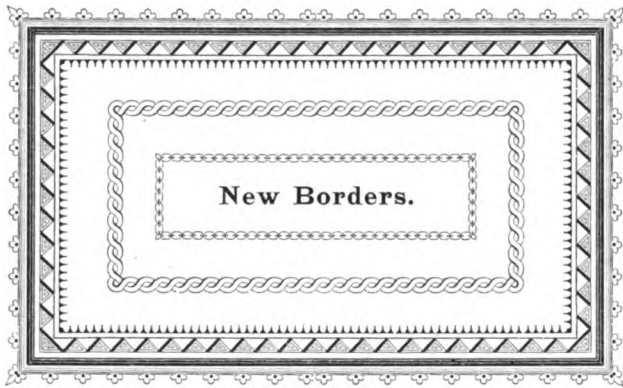
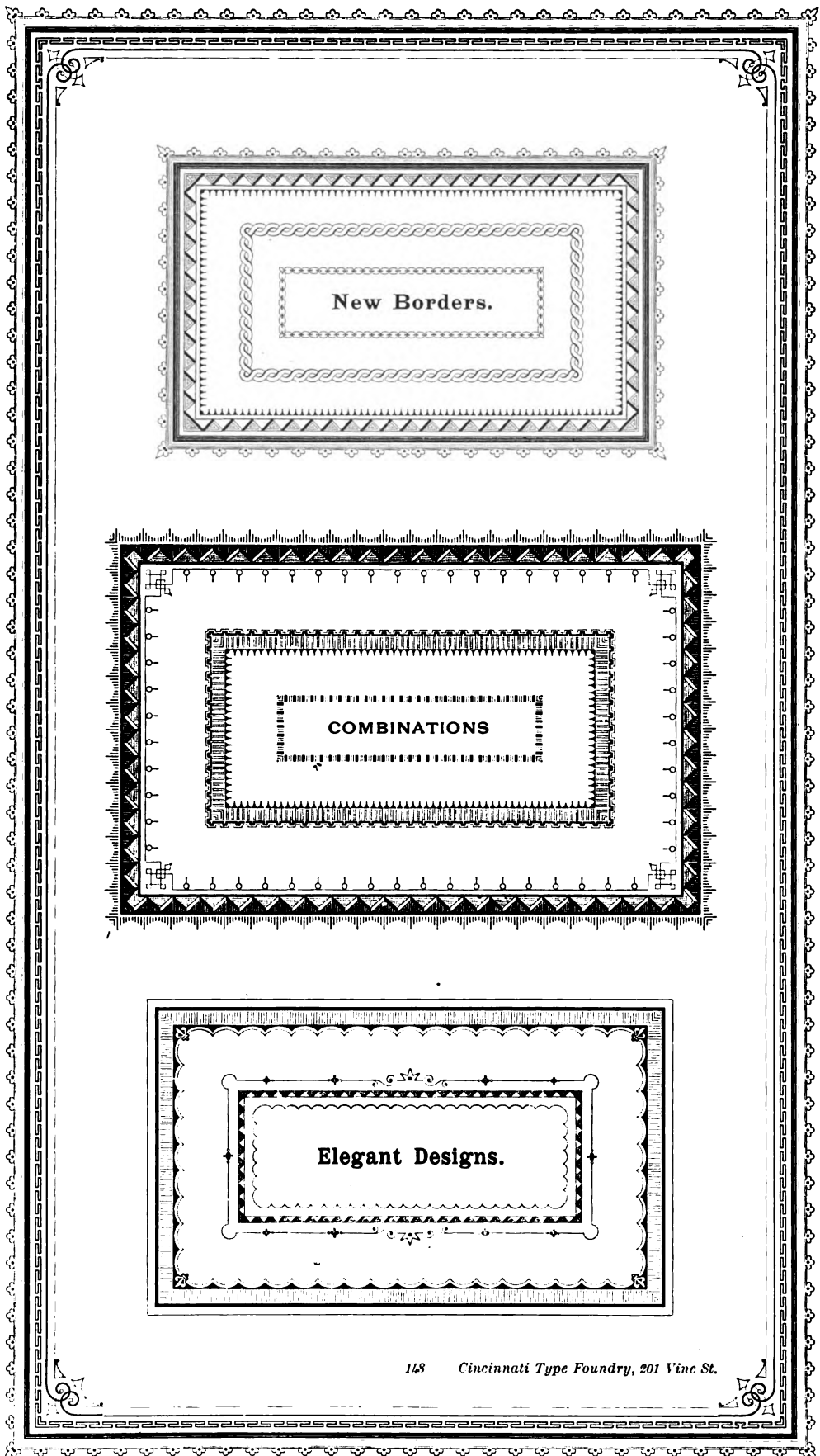

New Borders.

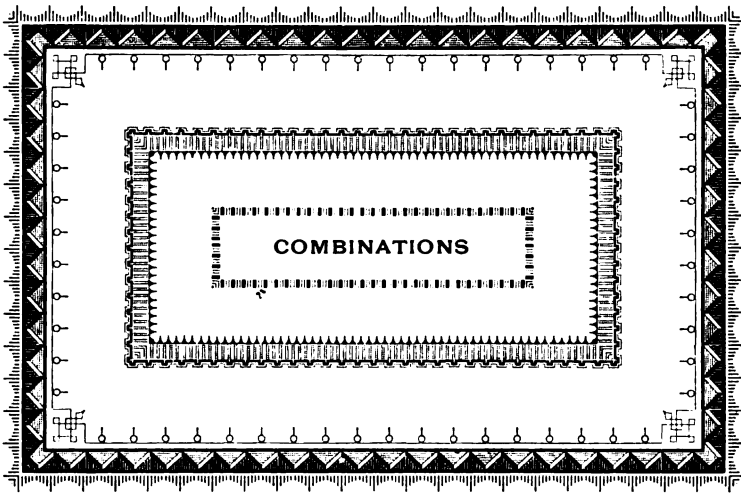

COMBINATIONS

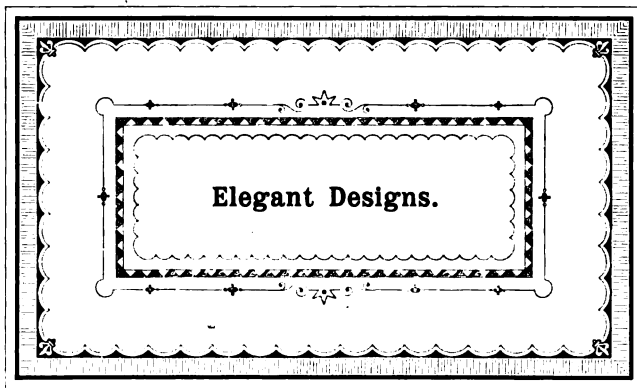

Elegant Designs.

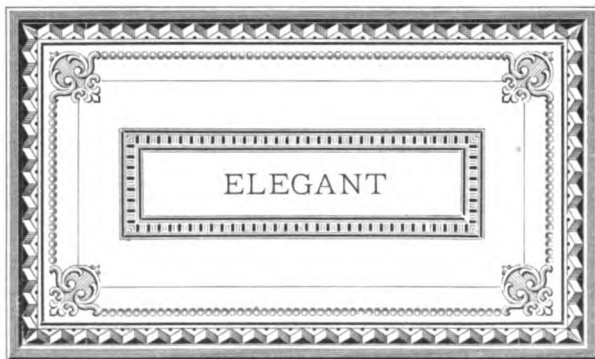
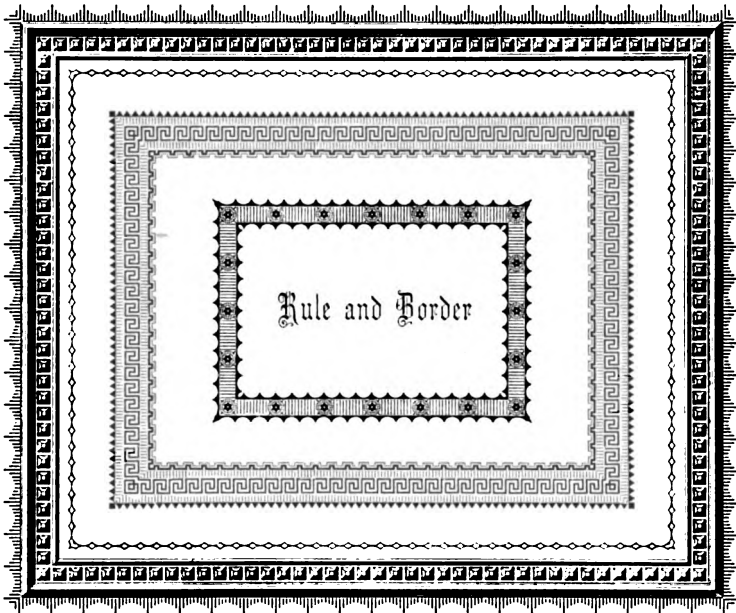
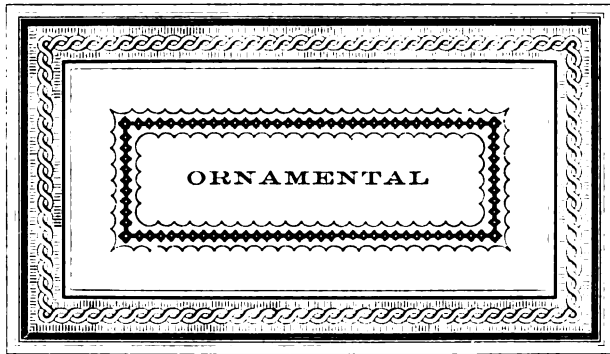

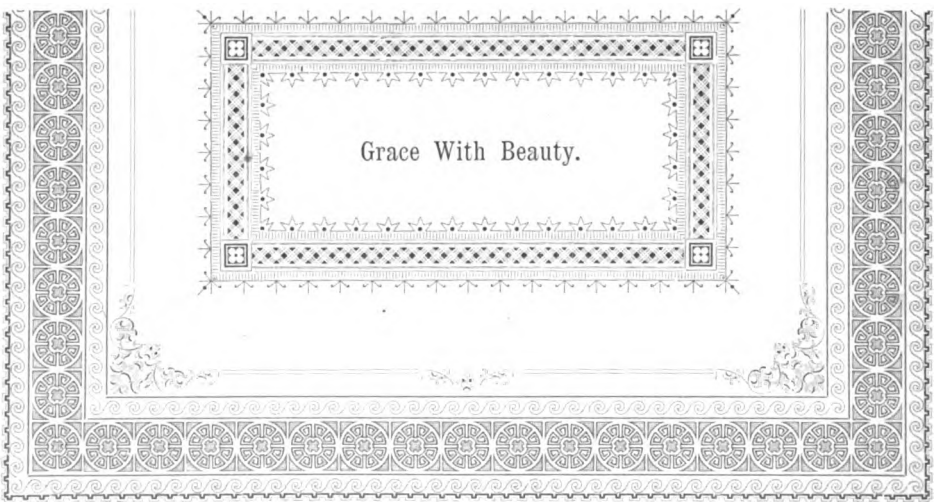
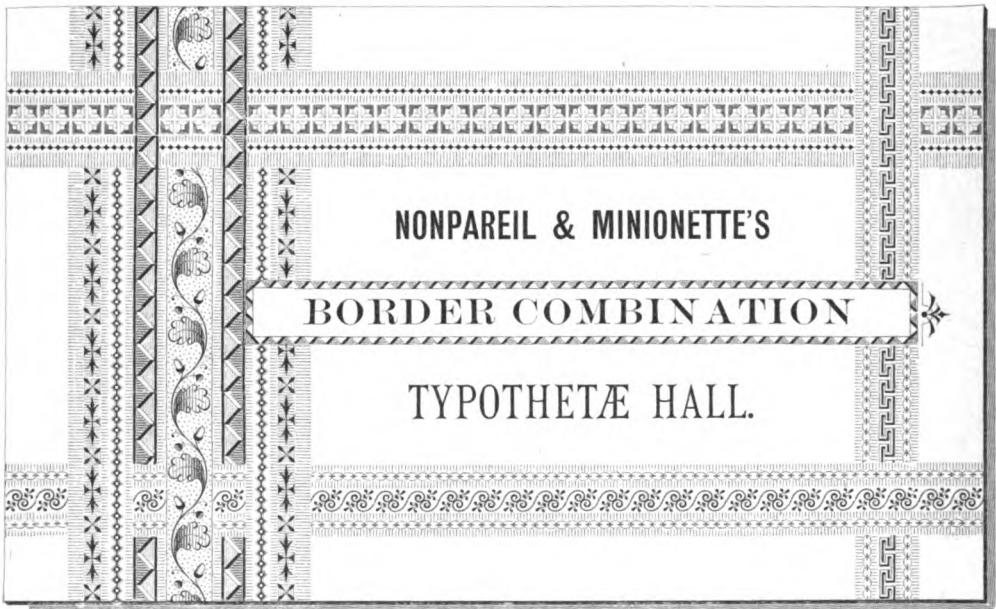
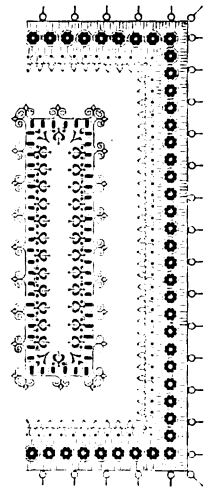
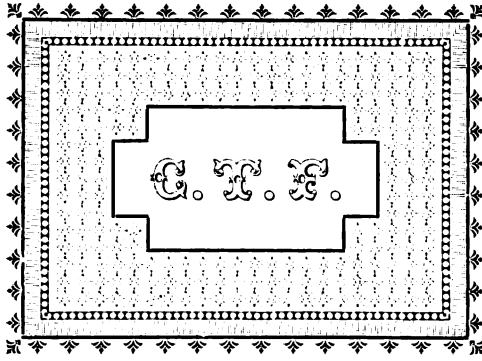
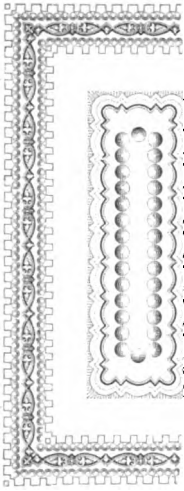

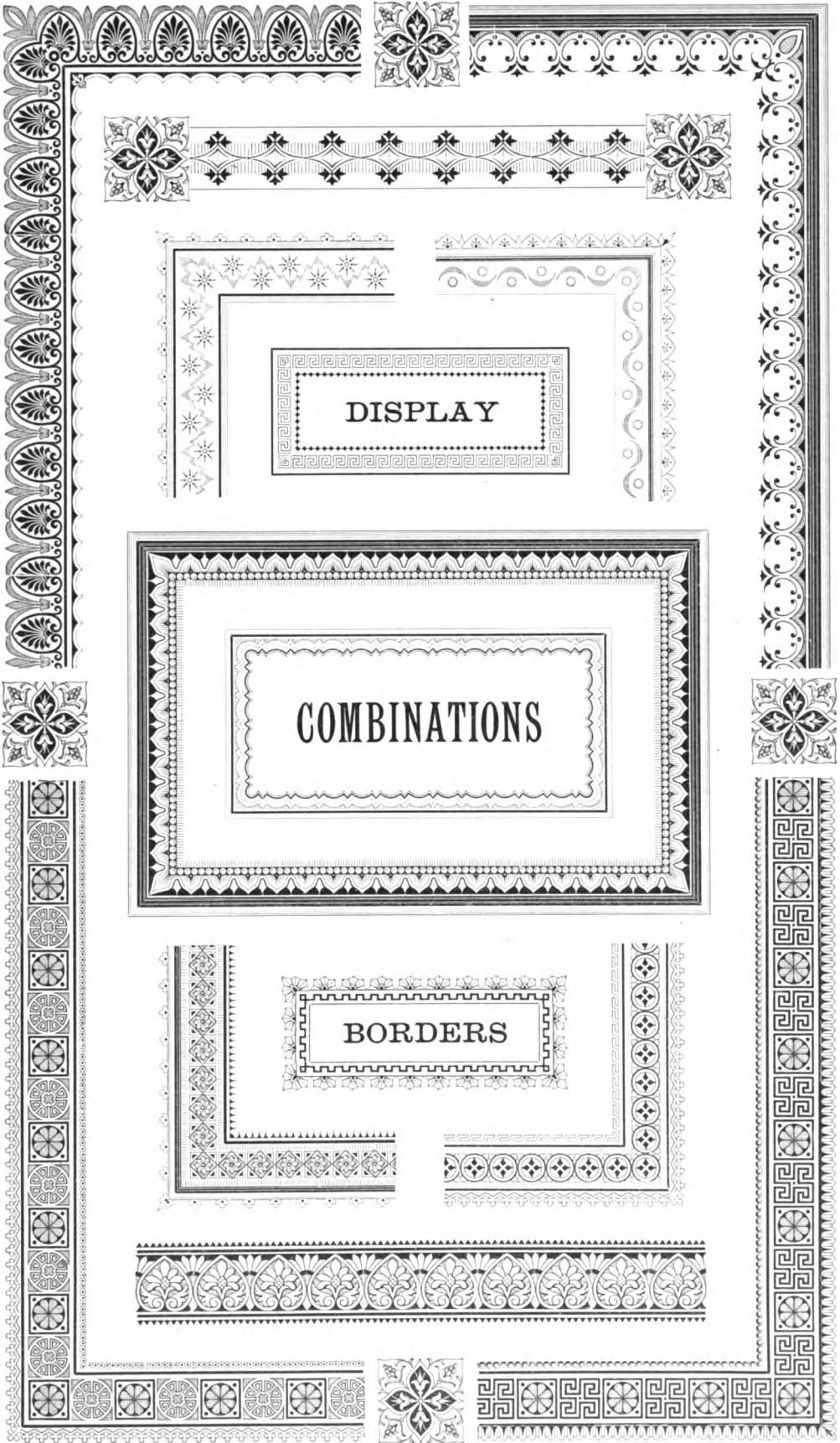

METAL CORNERS.

Per Set of Four Corners.

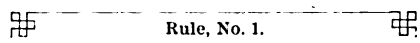
Corner No. 9. Per set, 25c.
 Rule, No. 1.

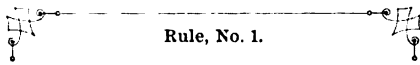
Corner No. 112. Per set, 25c.
 Rule, No. 1.

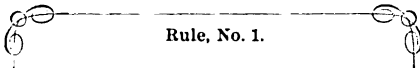
Corner No. 25. Per set, 30c.
 Rule, No. 1.

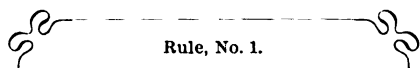
Corner No. 5. Per set, 30c.
 Rule, No. 1.

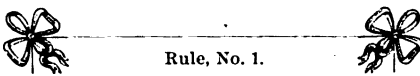
Corner No. 27. Per set, 30c.
 Rule, No. 1.

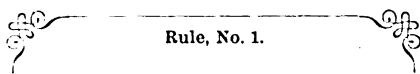
Corner No. 4. Per set, 30c.
 Rule, No. 1.

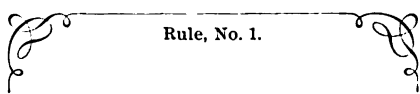
Corner No. 35. Per set, 30c.
 Rule, No. 1.

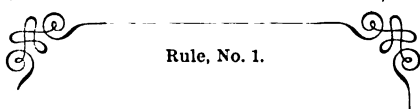
Corner No. 29. Per set, 40c.
 Rule, No. 1.

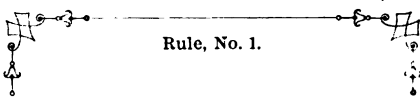
Corner No. 131. Per set, 30c.
 Rule, No. 1.

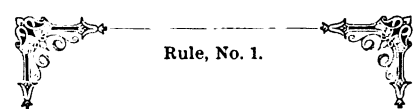
Corner No. 13. Per set, 40c.
 Rule, No. 1.

Corner No. 15. Per set, 40c.
 8 to Pica Rule No. 2.

Corner No. 18. Per set, 40c.
 8 to Pica Rule No. 2.

Corner No. 10. Per set, 40c.
 5 to Pica Rule No. 2.

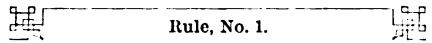
Corner No. 158. Per set, 25c.
 Rule, No. 1.

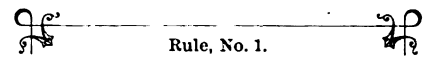
Corner No. 55. Per set, 25c.
 Rule, No. 1.

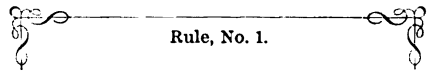
Corner No. 6. Per set, 30c.
 Rule, No. 1.

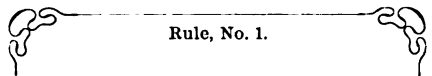
Corner No. 16. Per set, 30c.
 Rule, No. 1.

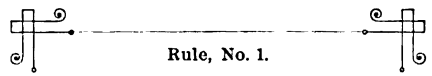
Corner No. 186. Per set, 30c.
 Rule, No. 1.

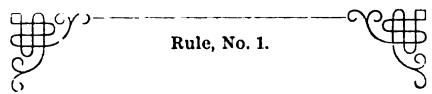
Corner No. 31. Per set, 30c.
 Rule, No. 1.

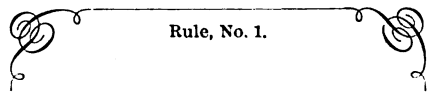
Corner No. 35½. Per set, 30c.
 Rule, No. 1.

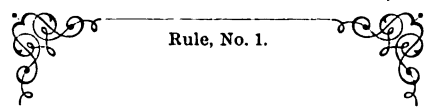
Corner No. 30. Per set, 40c.
 Rule, No. 1.

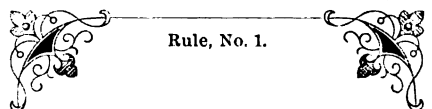
Corner No. 73. Per set, 30c.
 Rule, No. 1.

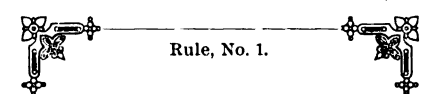
Corner No. 19. Per set, 40c.
 Rule, No. 1.

Corner No. 20. Per set, 40c.
 8 to Pica Rule No. 2.

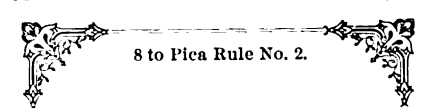
Corner No. 11. Per set, 40c.
 8 to Pica Rule No. 2.

Corner No. 12. Per set, 40c.
 6 to Pica Rule No. 2.

METAL CORNERS.

Per Set of Four Corners.

Corner No. 109. Per set, 20c.
 8 to Pica Rule No. 2.

Corner No. 124. Per set, 40c.
 5 to Pica Rule No. 2.

Corner No. 132. Per set, 30c.
 5 to Pica Rule No. 2.

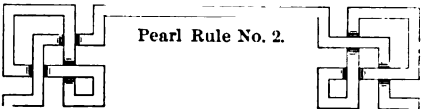
Corner No. 173. Per set, 40c.
 Pearl Rule No. 2.

Corner No. 111. Per set, 25c.
 Pearl Rule No. 3.

Corner No. 136. Per set, 30c.
 Pearl Rule No. 3.

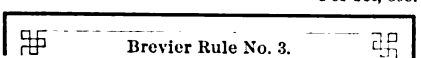
Corner No. 7. Per set, 30c.
 Brevier Rule No. 3.

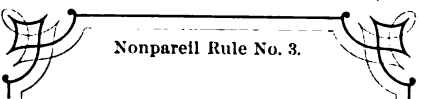
Corner No. 143. Per set, 40c.
 Nonpareil Rule No. 3.

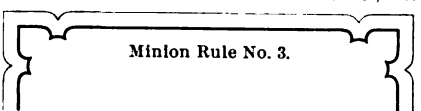
Corner No. 148. Per set, 40c.
 Minion Rule No. 3.

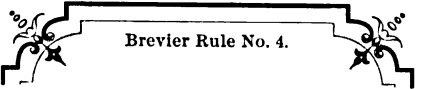
Corner No. 26. Per set, 40c.
 Brevier Rule No. 4.

Corner No. 152. Per set, 30c.
 Brevier Rule No. 3.

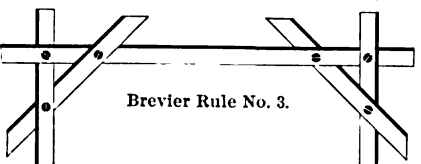
Corner No. 151. Per set, 50c.
 Brevier Rule No. 3.

Corner No. 166. Per set, 30c.
 8 to Pica Rule No. 2.

Corner No. 117. Per set, 30c.
 6 to Pica Rule No. 2.

Corner No. 24. Per set, 30c.
 6 to Pica Rule No. 2.

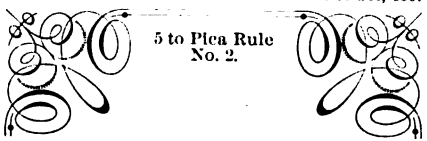
Corner No. 39. Per set, 40c.
 5 to Pica Rule No. 2.

Corner No. 113. Per set, 25c.
 Pearl Rule No. 4.

Corner No. 137. Per set, 30c.
 Pearl Rule No. 4.

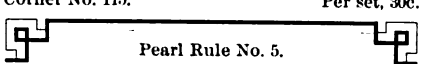
Corner No. 115. Per set, 30c.
 Pearl Rule No. 5.

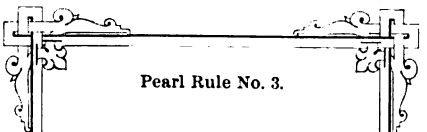
Corner No. 153. Per set, 50c.
 Pearl Rule No. 3.

Corner No. 144. Per set, 40c.
 Brevier Rule No. 3.

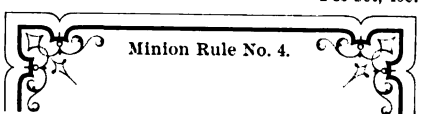
Corner No. 146. Per set, 40c.
 Minion Rule No. 4.

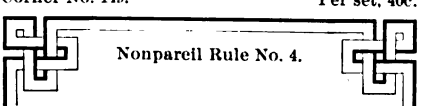
Corner No. 149. Per set, 40c.
 Nonpareil Rule No. 4.

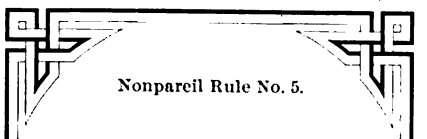
Corner No. 150. Per set, 50c.
 Nonpareil Rule No. 5.

METAL CORNERS.

Per Set of Four Corners.

Corner No. 189. Per set, 20c.

 4 to Pica Rule No. 7.

Corner No. 190. Per set, 20c.

 4 to Pica Rule No. 7.

Corner No. 192. Per set, 25c.

 4 to Pica Rule No. 7.

Corner No. 194. Per set, 25c.

 4 to Pica Rule No. 7.

Corner No. 164. Per set, 25c.

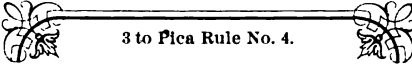
 6 to Pica Rule No. 7.

Corner No. 116. Per set, 25c.

 3 to Pica Rule No. 4.

Corner No. 195. Per set, 25c.

 3 to Pica Rule No. 13.

Corner No. 14. Per set, 40c.

 3 to Pica Rule No. 3.

Corner No. 165. Per set, 30c.

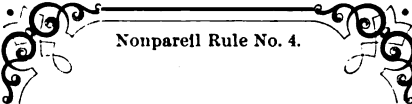
 4 to Pica Rule No. 8.

Corner No. 40. Per set, 40c.

 Nonpareil Rule No. 4.

Corner No. 130. Per set, 25c.

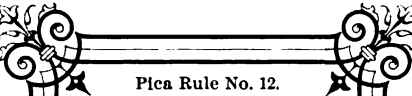
 Nonpareil Rule No. 13.

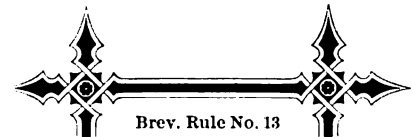
Corner No. 145. Per set, 40c.

 Pica Rule No. 12.

Corner No. 155. Per set, 50c.

 Brev. Rule No. 13

Corner No. 156. Per set, 50c.

 Minion Rule No. 13.

Corner No. 196. Per set, 20c.

 4 to Pica Rule No. 7.

Corner No. 191. Per set, 20c.

 4 to Pica Rule No. 7.

Corner No. 193. Per set, 25c.

 4 to Pica Rule No. 7.

Corner No. 197. Per set, 25c.

 Four to Pica Rule No. 7.

Corner No. 139. Per set, 40c.

 4 to Pica Rule No. 7.

Corner No. 171. Per set, 20c.

 4 to Pica Rule No. 7.

Corner No. 125. Per set, 30c.

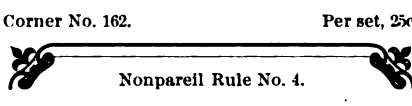
 Nonpareil Rule No. 4.

Corner No. 162. Per set, 25c.

 Nonpareil Rule No. 4.

Corner No. 161. Per set, 50c.

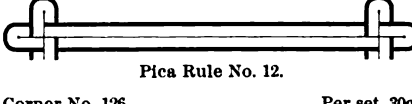
 3 to Pica Rule No. 4.

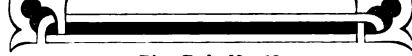
Corner No. 141. Per set, 30c.

 Pica Rule No. 12.

Corner No. 126. Per set, 30c.

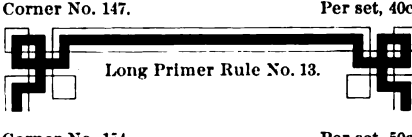
 Pica Rule No. 13.

Corner No. 129. Per set, 30c.

 Pica Rule No. 8.

Corner No. 147. Per set, 40c.

 Long Primer Rule No. 13.

Corner No. 154. Per set, 50c.

 Minion Rule No. 13.

METAL CORNERS.

Per set of Four Corners.

Corner No. 101. Per set, 25c.



Nonpareil Rule No. 14.

Corner No. 110. Per set, 25c.



Brevier Rule No. 14.

Corner No. 121. Per set, 30c.

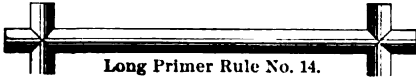

Long Primer Rule No. 14.

Corner No. 118. Per set, 30c.

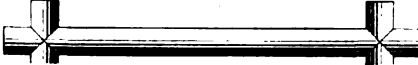

Pica Rule No. 14.

Corner No. 114. Per set, 40c.



Minion Rule No. 14.

Corner No. 138. Per set, 50c.

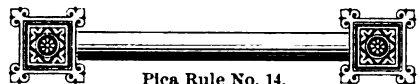

Pica Rule No. 14.

Corner No. 142. Per set, 40c.



Nonpareil Rule No. 14.

Corner No. 174. Per set, 40c.



Nonpareil Rule No. 16.

Corner No. 187. Per set, 40c.



Nonpareil and one-half Rule No. 16.

Corner No. 188. Per set, 40c.



Pica Rule No. 16.

Corner No. 60. Per set, 25c.

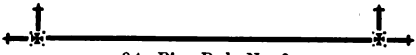

8 to Pica Rule No. 0.

Corner No. 157. Per set, 20c.



6 to Pica Rule No. 158.

Corner No. 52. Per set, 25c.



8 to Pica Pica Rule No. 0.

Corner No. 180. Per set, 20c.

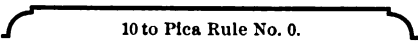

10 to Pica Rule No. 0.

Corner No. 58. Per set, 25c.

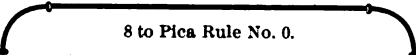

8 to Pica Rule No. 0.

Corner No. 181. Per set, 20c.

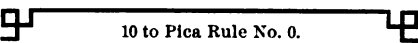

10 to Pica Rule No. 0.

Corner No. 59. Per set, 25c.

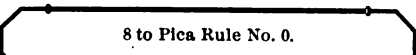

8 to Pica Rule No. 0.

Corner No. 182. Per set, 30c.

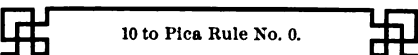

10 to Pica Rule No. 0.

Corner No. 57. Per set, 25c.

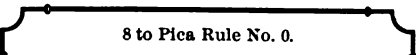

8 to Pica Rule No. 0.

Corner No. 179. Per set, 30c.

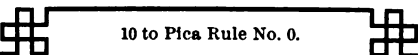

10 to Pica Rule No. 0.

Corner No. 54. Per set, 40c.

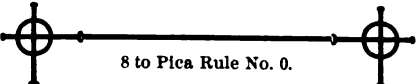

8 to Pica Rule No. 0.

Corner No. 183. Per set, 40c.

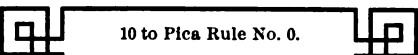

10 to Pica Rule No. 0.

Corner No. 61. Per set, 40c.



6 to Pica Rule No. 0.

Corner No. 178. Per set, 40c.



10 to Pica Rule No. 10.

Corner No. 185. Per set, 50c.

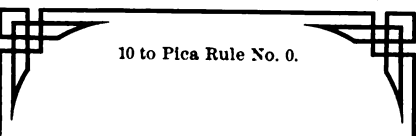

10 to Pica Rule No. 0.

Corner No. 177. Per set, 50c.

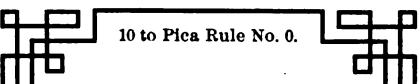

10 to Pica Rule No. 0.

Corner No. 184. Per set, 50c.

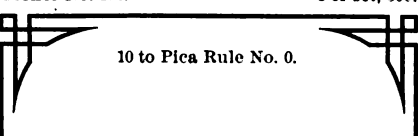

10 to Pica Rule No. 0.

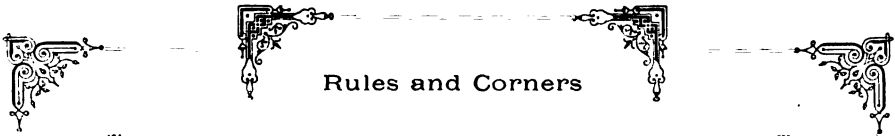

Rules and Corners

Eight-to-Pica Labor Saving Rule, No. 2.

Fonts of 10 feet, 12 oz., \$1.50.

Fonts of 10 feet, including two sets of each Corner-piece, \$3.50.

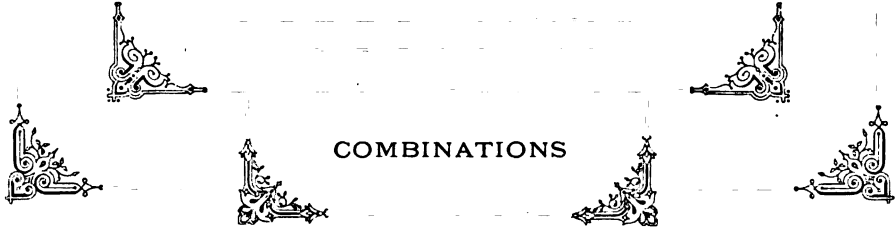

COMBINATIONS

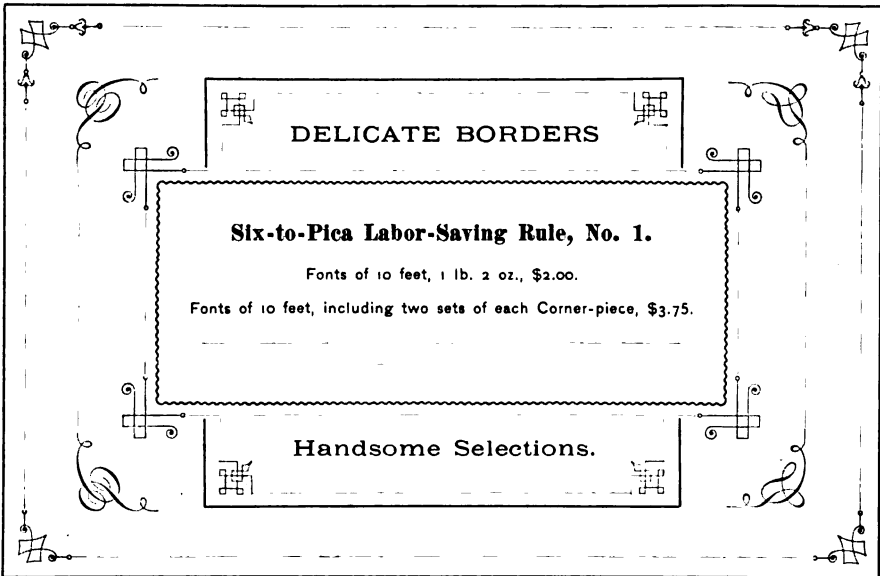

DELICATE BORDERS

Six-to-Pica Labor-Saving Rule, No. 1.

Fonts of 10 feet, 1 lb. 2 oz., \$2.00.

Fonts of 10 feet, including two sets of each Corner-piece, \$3.75.

Handsome Selections.

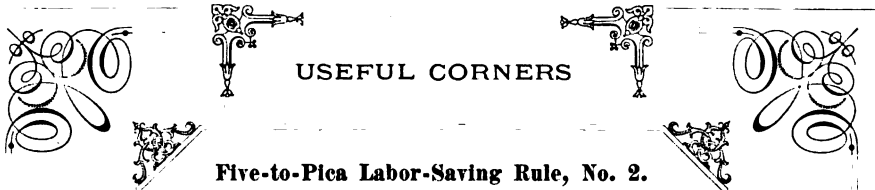

USEFUL CORNERS

Five-to-Pica Labor-Saving Rule, No. 2.

Fonts of 10 feet, 1 lb. 2 oz., \$2.00.

Fonts of 10 feet, including two sets of each Corner-piece, \$3.50.

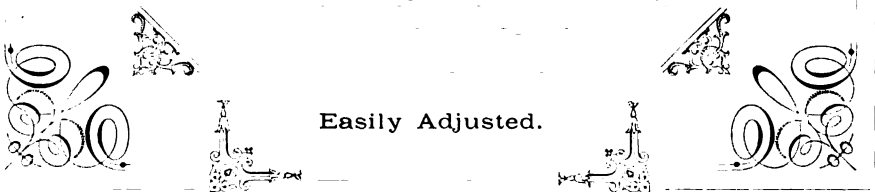

Easily Adjusted.

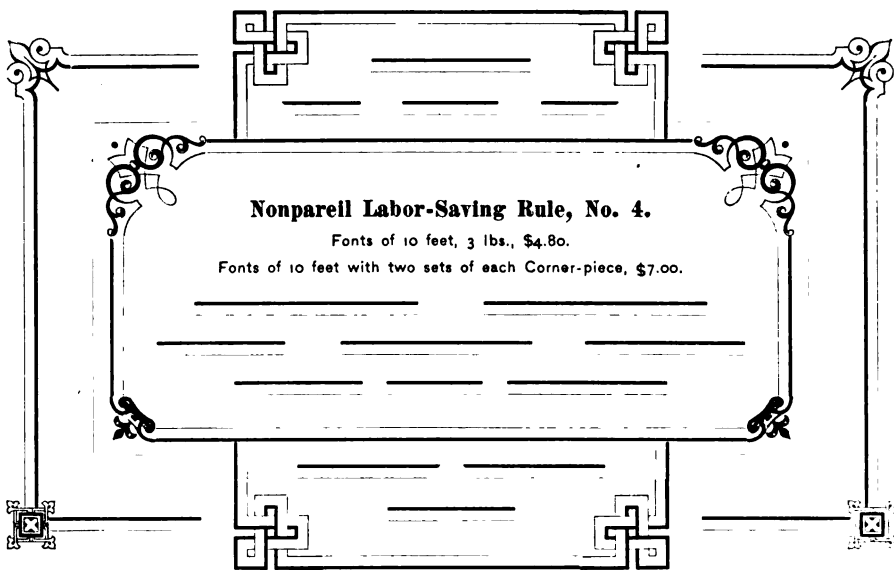
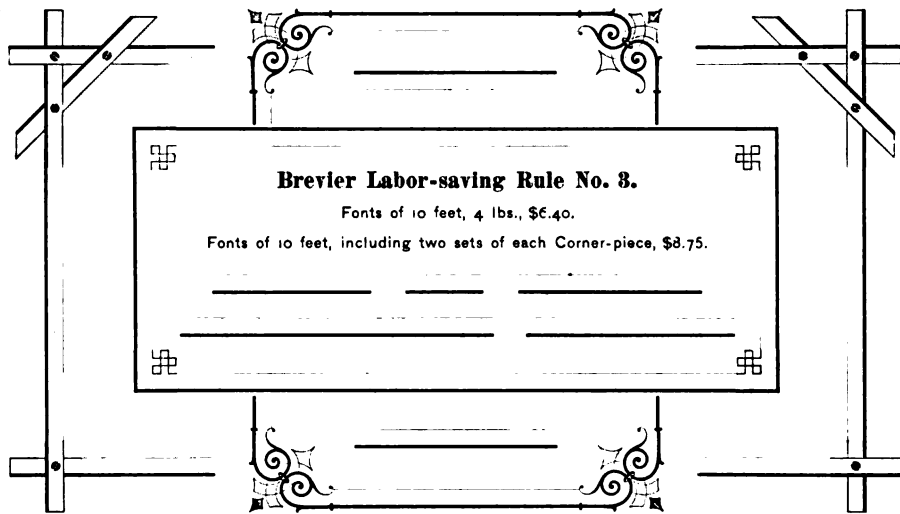
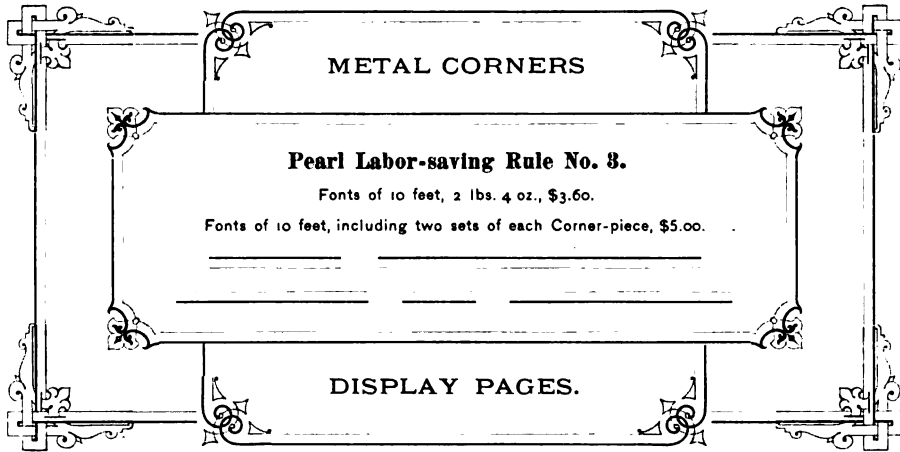

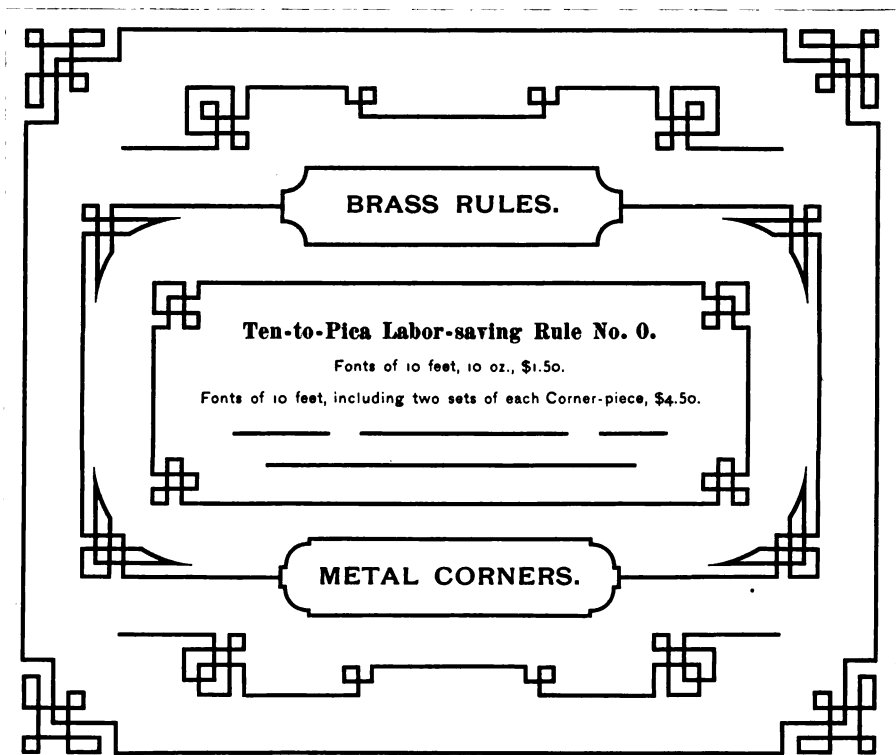
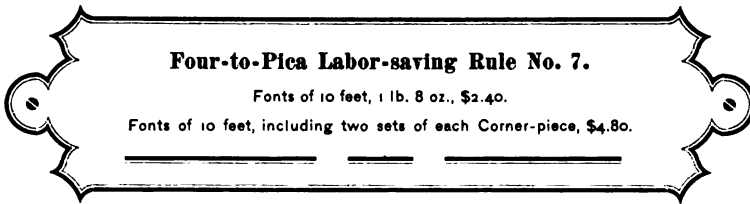
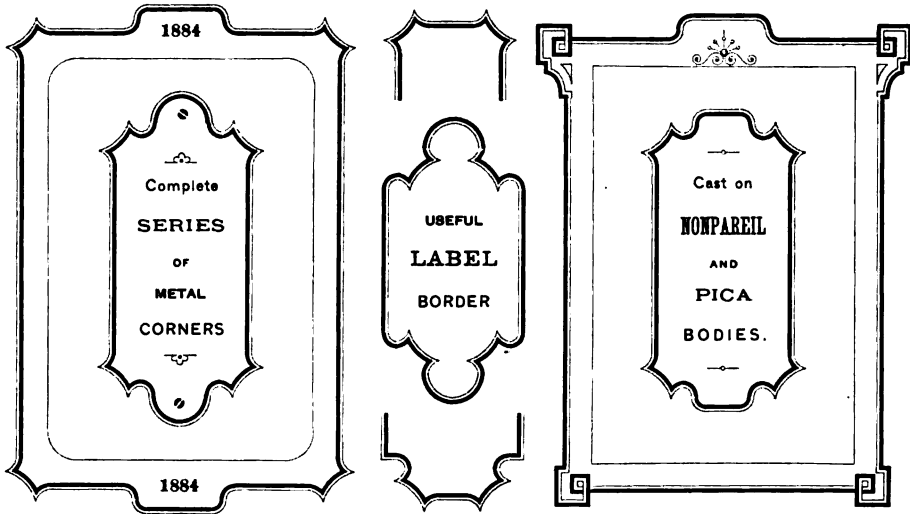

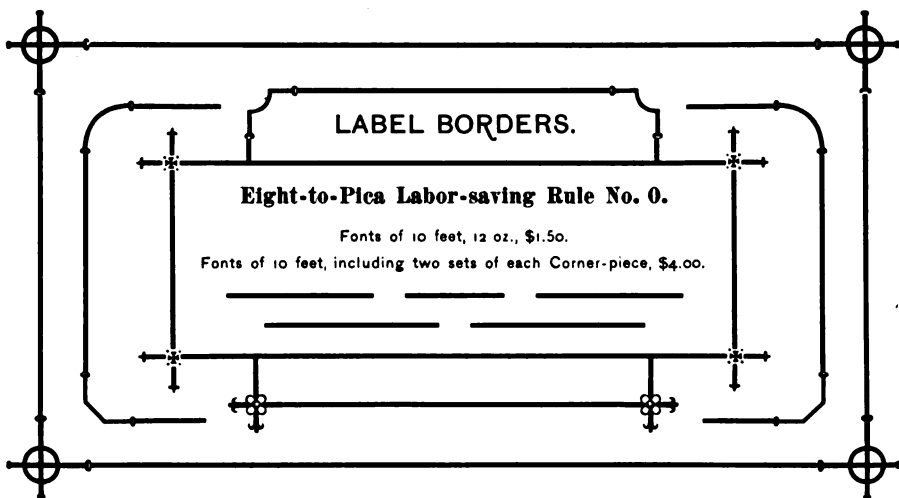
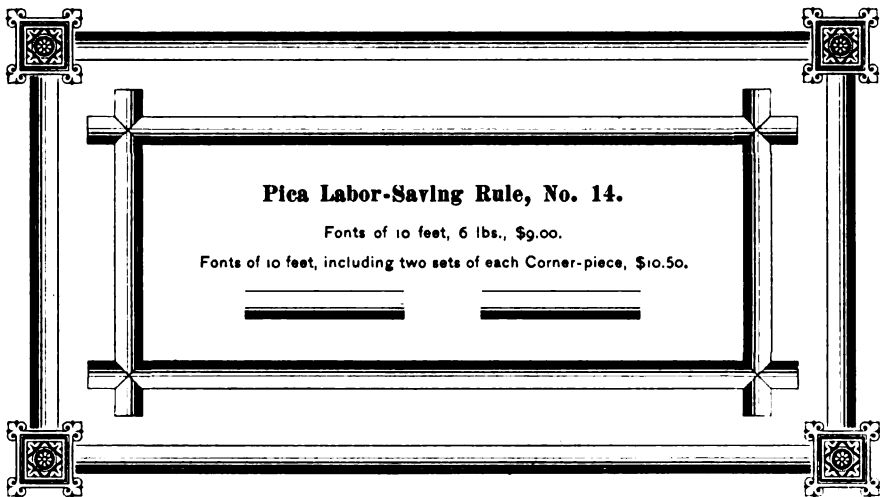
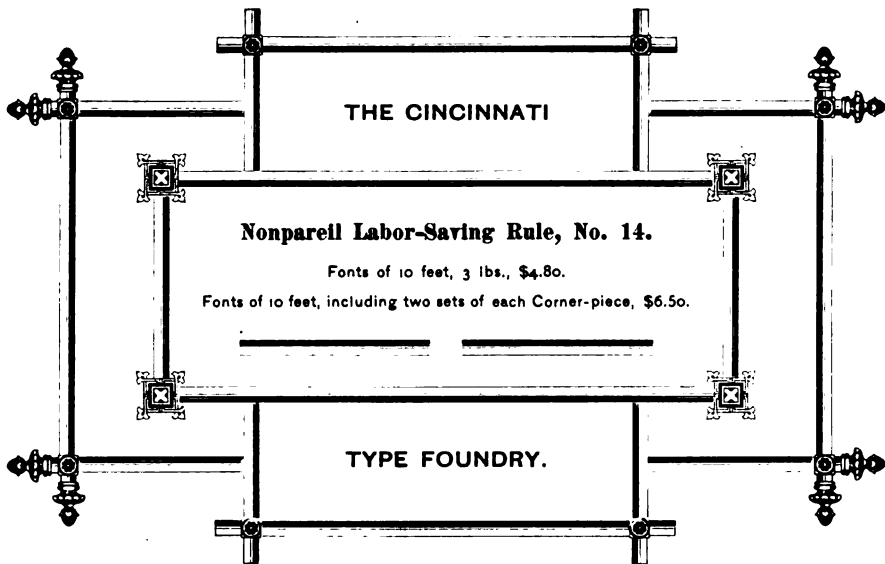

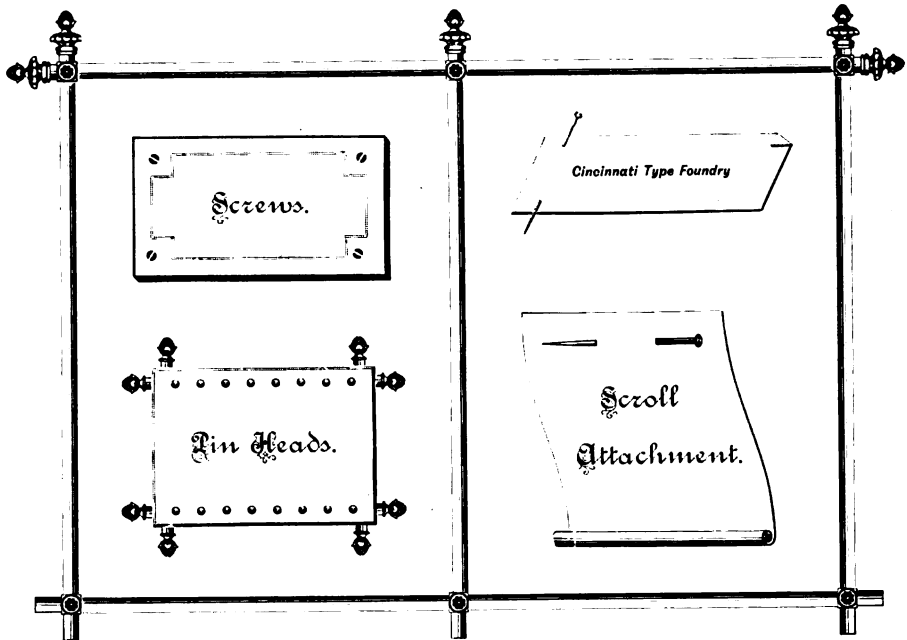

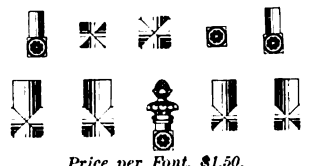

RULES AND ORNAMENTS.
THE CINCINNATI TYPE FOUNDRY,
 No. 201 Vine Street.

<p style="text-align: center;">RULE ORNAMENTS..</p>  <p style="text-align: center;"><i>Price per Font, \$1.50.</i></p>	<p style="text-align: center;">PINS, SCREW HEADS. ETC.</p> <p style="text-align: center;"><i>Per Font, 75 cents.</i></p>  <p style="text-align: center;">MAILING LOGOTYPES.</p> <p style="text-align: center;"><i>Long Primer body.</i></p> <p style="text-align: center;"> Dec. Nov. Oct. Sep. Aug. Jul. Jun. May. Apr. Mar. Feb. Jan. </p>
<p style="text-align: center;">FIVE-POINTED STARS.</p>  <p style="text-align: center;"><i>Price per Font, 4 of each, \$1.00.</i></p>	<p style="text-align: center;">MEDICAL SIGNS.</p> <p style="text-align: center;"> 3 € 3 Ɔ φ ψ R R̄ </p> <p style="text-align: center;"> 1. 3. 10¢ 5. 10¢ 4. 10¢ 2. </p> <p style="text-align: center;"> R̄ R̄ R̄ R̄ R̄ </p>

BRASS FLOURISHES

WHOLE FONT, \$8.00.

PATENTED.

HALF FONT, \$5.00.

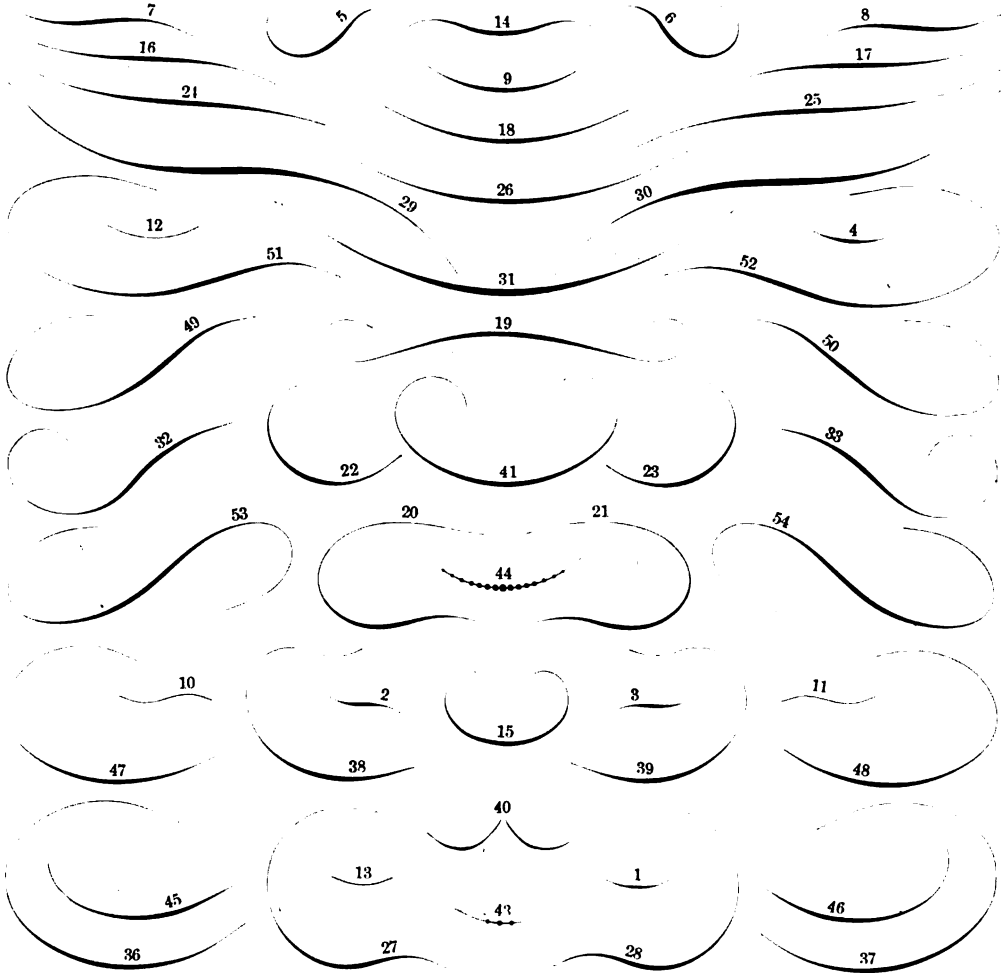

HOMER & BURTON

JOB PRINTERS,

AND



PAPER DEALERS

BOOKBINDING IN ALL
BRANCHES.

No. 4 Chesnut St. Madison, O.

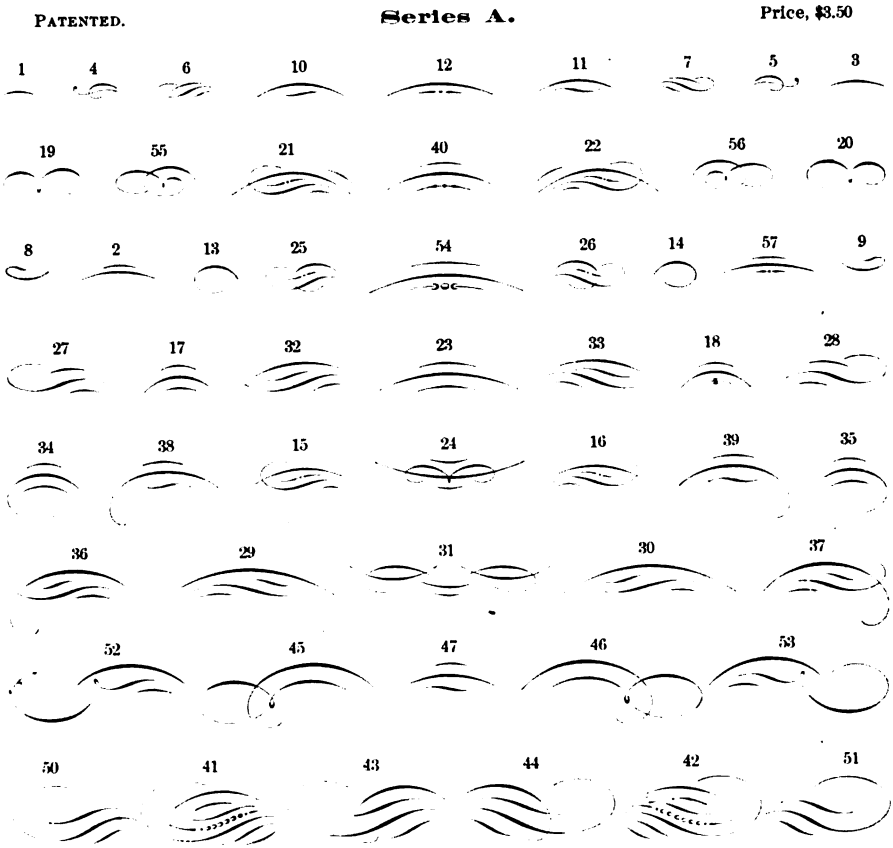
NEW METAL FLOURISHES



PRINTING MATERIAL
JOB AND NEWSPAPER
TYPE * AND * PRESSES
ALSO
OFFICE FURNITURE

Flourishes cast by
Cincinnati Type Foundry

HENDERSON & BROCKTON
 DRY GOODS
BOOTS AND SHOES
 AND
FURNISHING GOODS

PRESENTED BY J. HENDERSON. EAST SALEM, MASS.

A. C. MAINE
MAINE & JONES
B. D. JONES
 STATIONERS
General Printers
 AND
 ENGRAVERS
56 FOURTH STREET
SAN FRANCISCO

R. E. HOLDEN.
 ESTABLISHED 1875.
 JAS. E. SMITH.
HOLDEN & SMITH
 DEALERS IN
Cigars and Tobacco
 AND
 FINE MEERSCHAUM GOODS.
Cor. Pearl and New Sts.
MILWAUKEE, WIS.

TYPOGRAPHIC FLOURISHES

PATENTED.

Series B.

Price, \$6.00.

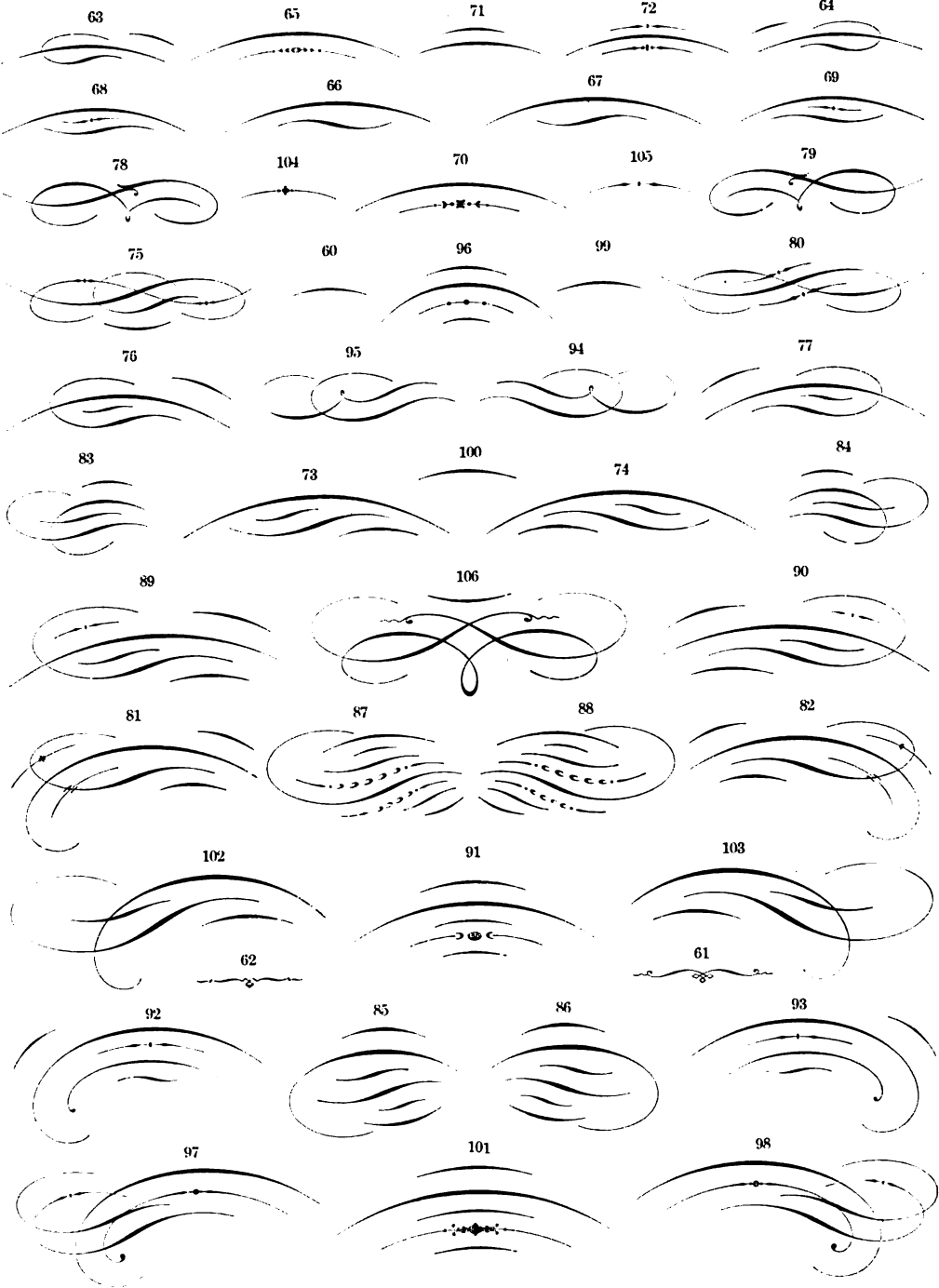

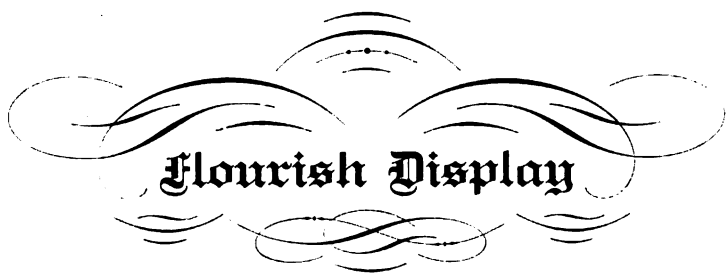

Flourish Display

CHARACTERS FROM SERIES B.

CAST BY CINCINNATI TYPE FOUNDRY.

NEW

METAL * FLOURISHES

FROM THE

CINCINNATI TYPE FOUNDRY

PATENTED. PRICE, \$6.00

CAPITAL, \$1,250,000. ASSETS, \$1,500,000.

THE GLOBE

MUTUAL

Fire Insurance Co.

OF

HARTFORD CITY, CONN.

JOHN RATCLIFF, PRESIDENT. CHAS. E. BROWN, SECRETARY AND TREAS.

BRASS CURVES & CLAMPS



MANUFACTURED BY

CINCINNATI TYPE FOUNDRY.

FONTS OF 160 PIECES. PRICE, - - - \$8.00.

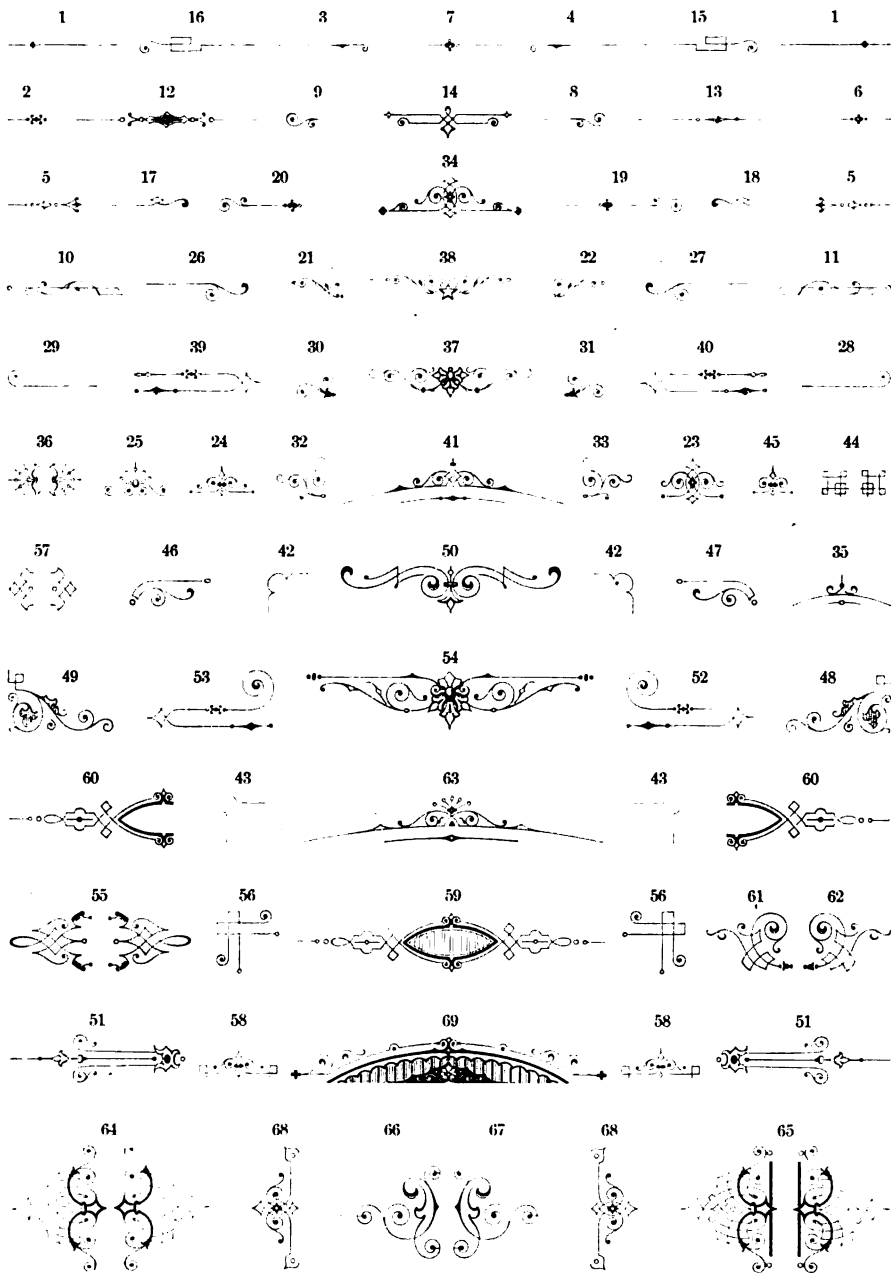
Card Ornaments
 CAST BY
THE CINCINNATI TYPE FOUNDRY
 PATENTED.
 Fonts, 3 $\frac{3}{4}$ pounds. Price, \$3.75.



HOMER JOHNSTON,
 PUBLISHER OF
HOUSTON + JOURNAL
 OFFICE,
 CRESCENT AVENUE, DELPHOS.



 H. BARTH, PRES. W. P. HUNT, TREAS.
CINCINNATI

TYPE FOUNDRY

 No. 201 VINE STREET

HENRY B. KIRK. JOHN GIBSON.

KIRK & GIBSON
 DEALERS IN
Musical Instruments
 AND
SHEET MUSIC, STRINGS, ETC.

 207 Clark Avenue, SANDUSKY, O.

TYPOGRAPHIC CHARMS.

Patent Pending.

Price per Font, \$6.50.

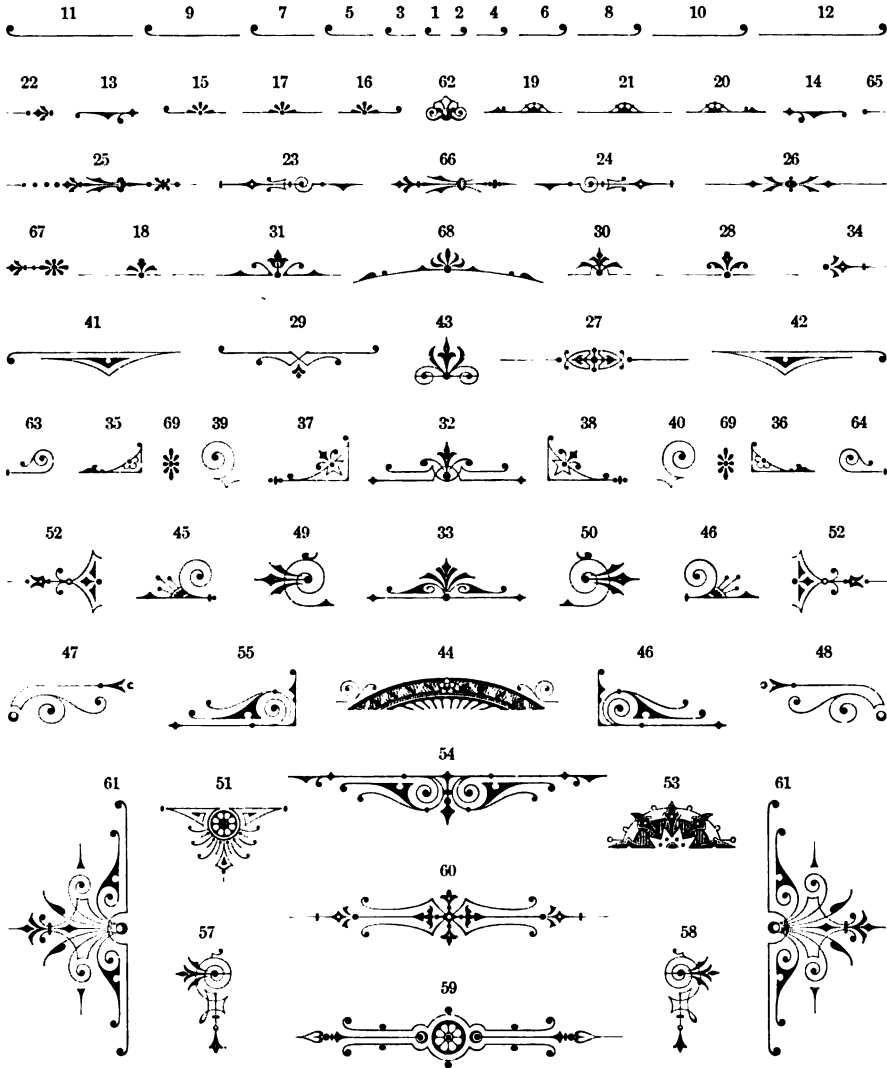

All of the above Characters are even Nonpareils bodyways as well as in length.

New and Handsome Ornaments

Select Programme.

Order of Dances.

- 1.—Waltz.
- 2.—Schottische.
- 3.—Quadrille.
- 4.—Polka.
- 5.—Varsoviene.
- 6.—Waltz.
- 7.—Quadrille.
- 8.—Schottische.
- 9.—Grand March.

Supper.

Order of Dances.

- 10.—Quadrille.
- 11.—Mazurka.
- 12.—Waltz.
- 13.—Schottische.
- 14.—Galop.
- 15.—Quadrille.
- 16.—Waltz.
- 17.—Quadrille.
- 18.—Reel.

farewell.

BILL OF FARE

DISHES.

Roast Beef.
Stewed Veal.
Potatoes.
Vegetables.

DESSERT.

Chocolate.
Ice Cream.
Puddings.
Jellies.

WINE LIST

Champagne. St. Andre Claret.
St. Julien. Sherry. Riesling.

HUNTINGTON
PALACE HOTEL

SPECIALTIES

FIRST-CLASS

DRUM CYLINDERS,

— IMPROVED —

NONPAREIL JOBBER,

UNIVERSAL

RULE SHAPER,

— PATENT —

LEAD CUTTER

MONTHLY STATEMENT

BLUELICK REFINERY

THIRD AVENUE, MARION, TENN.

RECEIVED OF

BOUGHT OF

COBDEN & RUBENS,

PUBLISHERS OF

RICHMOND RECORDER,

MONROE COUNTY, IOWA.

BRASS
CIRCLES
AND
OVALS.

BRASS
CURVES
AND
CLAMPS.

FASHION

M

MAGAZINE.

TYPOGRAPHIC + CHARMS

H. BARTH, PRES. WM. P. HUNT, TREAS.

THE CINCINNATI

TYPE FOUNDRY,

OFFICE, 201 VINE STREET.

PRINTING MACHINERY. CASES AND CABINETS.

Improved
Power
Presses

NEW DESIGNS
IN
BORDERS,
ORNAMENTS,
RULES
AND
+ TYPES +

DASHES
Rules
AND
LEADS.



BRASS RULES.

GR^EAT attention has been paid to the organization of our Rule Department, in the gradation of the series, and uniformity of height and body.

Any of our standard series of Rules are sufficiently accurate to be cut into Labor-saving Fonts, and may be so ordered by our patrons at their pleasure.

That class of Rules known as Miscellaneous, however, we have found next to impossible to make sufficiently uniform to answer, practically, for labor-saving fonts.

To supply the demand for such fonts of Waved, Scalloped, Pinched and Dotted Rules, we reproduced those forms in type metal borders, among such they will be found.

Very many so-called Brass Rules offered in the market are unworthy of the name, and utterly fail to print a uniform line from end to end on fine paper and a hard tympan. If you have any such difficulty, try ours.



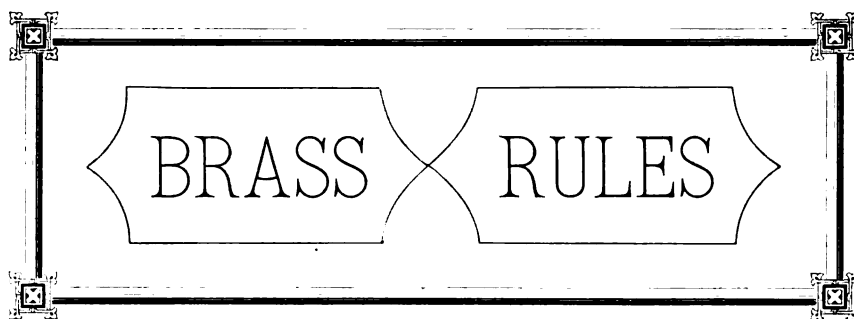

BRASS RULES.

Series 1.

Pica No. 1.

Long Primer No. 1.

Brevier No. 1.

Minion No. 1.

Nonpareil No. 1.

Pearl No. 1.

3 to Pica No. 1.

4 to Pica No. 1.

5 to Pica No. 1.

6 to Pica No. 1.

8 to Pica No. 1.

10 to Pica No. 1.

Series 3.

Pica No. 3.

Long Primer No. 3.

Brevier No. 3.

Minion No. 3.

Nonpareil No. 3.

Pearl No. 3.

3 to Pica No. 3.

4 to Pica No. 3.

Series 2.

Pica No. 2.

Long Primer No. 2.

Brevier No. 2.

Minion No. 2.

Nonpareil No. 2.

Pearl No. 2.

3 to Pica No. 2.

4 to Pica No. 2.

5 to Pica No. 2.

6 to Pica No. 2.

8 to Pica No. 2.

10 to Pica No. 2.

Series 4.

Pica No. 4.

Long Primer No. 4.

Brevier No. 4.

Minion No. 4.

Nonpareil No. 4.

Pearl No. 4.

3 to Pica No. 4.

4 to Pica No. 4.

BRASS RULES.

Series 5.

Pica No. 5.

Long Primer No. 5.

Brevier No. 5.

Minion No. 5.

Nonpareil No. 5.

Pearl No. 5.

3 to Pica No. 5.

4 to Pica No. 5.

Series 7.

Pica No. 7.

Long Primer No. 7.

Brevier No. 7.

Minion No. 7.

Nonpareil No. 7.

Pearl No. 7.

3 to Pica No. 7.

4 to Pica No. 7.

Series 6.

Pica No. 6.

Long Primer No. 6.

Brevier No. 6.

Minion No. 6.

Nonpareil No. 6.

Pearl No. 6.

3 to Pica No. 6.

4 to Pica No. 6.

Series 8.

Pica No. 8.

Long Primer No. 8.

Brevier No. 8.

Minion No. 8.

Nonpareil No. 8.

Pearl No. 8.

3 to Pica No. 8.

4 to Pica No. 8.

For prices see Price List.

173

Cincinnati Type Foundry, 301 Vine St.

BRASS RULES.

Series O.

Pica No. 0.



Long Primer No. 0.



Brevier No. 0.



Minion No. 0.



Nonpareil No. 0.



Pearl No. 0.



3 to Pica No. 0.



4 to Pica No. 0.



5 to Pica No. 0.



6 to Pica No. 0.



8 to Pica No. 0.



10 to Pica No. 0.



12 to Pica No. 0.



Miscellaneous.

6 to Pica No. 159.

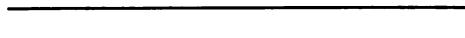

6 to Pica No. 158.



6 to Pica No. 169.



6 to Pica No. 168.



12 to Pica No. 1.

Series 13.

Pica No. 13.



Long Primer No. 13.

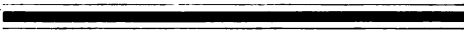

Brevier No. 13.



Minion No. 13.

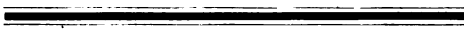

Nonpareil No. 13.

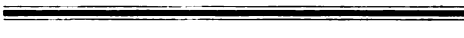

Pearl No. 13.

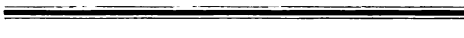

3 to Pica No. 13.



4 to Pica No. 13.



Miscellaneous.

Brevier No. 147†.



Minion No. 146†.



Pearl No. 105†.



Brevier No. 143†.



Nonpareil No. 142†.



Pearl No. 102†.

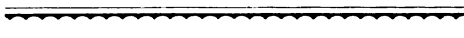

Nonpareil No. 108†.



Pearl No. 144†.



All Rules except those thus designated (+) can be made in labor-saving fonts to order. Waved and Scalloped Rules have been imitated in Borders, for which see another page.

BRASS RULES.

Series 12.

Pica No. 12.

Long Primer No. 12.

Brevier No. 12.

Minion No. 12.

Nonpareil No. 12.

Pearl No. 12.

3 to Pica No. 12.

4 to Pica No. 12.

Series 16.

Pica No. 16.

Nonpareil and one-half No. 16.

Nonpareil No. 16.

Miscellaneous.

Nonpareil and one-half No. 19.

Nonpareil No. 20.

Nonpareil No. 21.

5 to Pica No. 86†.

6 to Pica No. 7.

6 to Pica No. 77†.

6 to Pica No. 171†.

6 to Pica No. 170†.

6 to Pica No. 74†.

6 to Pica No. 71.

8 to Pica No. 71.

Series 14.

English No. 14.

Pica No. 14.

Long Primer No. 14.

Nonpareil and one-half No. 14.

Brevier No. 14.

Minion No. 14.

Nonpareil No. 14.

Pearl No. 14.

Series 18.

Pica No. 18.

Nonpareil and one-half No. 18.

3 to Pica No. 18.

Miscellaneous.

Pica No. 17.

Nonpareil and one-half No. 15.

Nonpareil No. 15.

6 to Pica No. 166†.

6 to Pica No. 5.

6 to Pica No. 173†.

6 to Pica No. 172†.

6 to Pica No. 75†.

6 to Pica No. 73†.

6 to Pica No. 72†.

6 to Pica No. 137.

All Rules except those thus designated (†) can be made in labor-saving fonts to order. Waved and Scalloped Rules have been imitated in Borders, for which see another page.

For prices see Price List.

177

Cincinnati Type Foundry, 201 Vine St.

Labor-Saving Brass Rule.

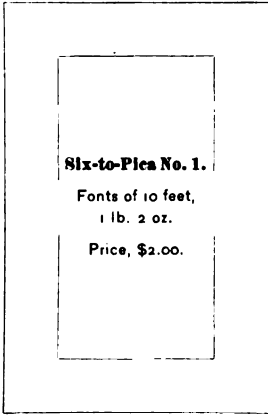

Six-to-Pica No. 1.
 Fonts of 10 feet,
 1 lb. 2 oz.
 Price, \$2.00.

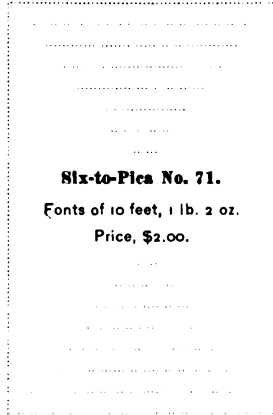

Six-to-Pica No. 71.
 Fonts of 10 feet, 1 lb. 2 oz.
 Price, \$2.00.

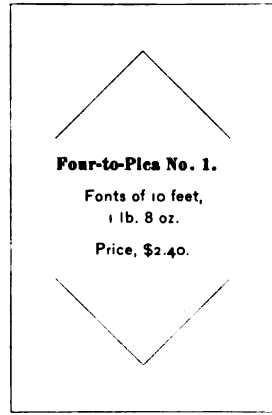

Four-to-Pica No. 1.
 Fonts of 10 feet,
 1 lb. 8 oz.
 Price, \$2.40.



Six-to-Pica No. 2.
 Fonts of 10 feet, 1 lb. 2 oz.
 Price, \$2.00.

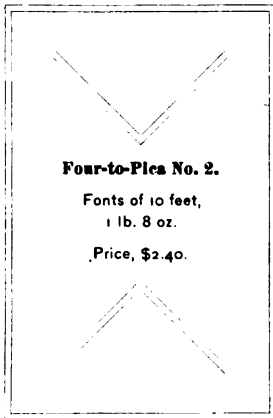

Four-to-Pica No. 2.
 Fonts of 10 feet,
 1 lb. 8 oz.
 Price, \$2.40.

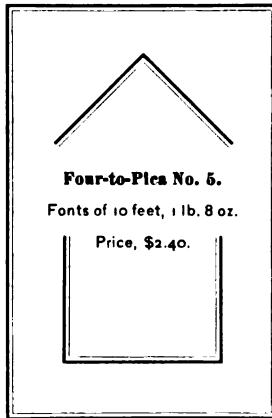

Four-to-Pica No. 5.
 Fonts of 10 feet, 1 lb. 8 oz.
 Price, \$2.40.

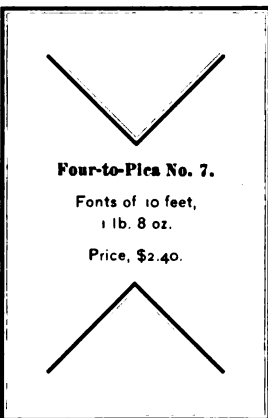

Four-to-Pica No. 7.
 Fonts of 10 feet,
 1 lb. 8 oz.
 Price, \$2.40.

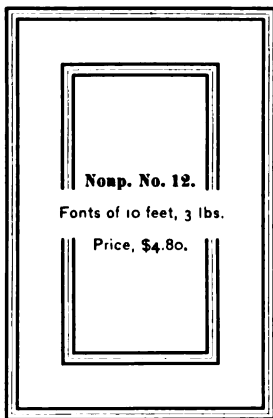

Nonp. No. 12.
 Fonts of 10 feet, 3 lbs.
 Price, \$4.80.

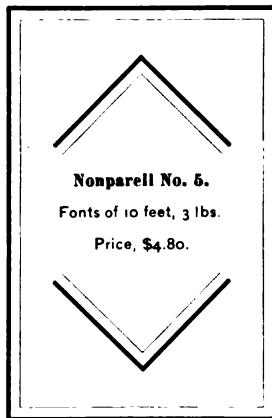

Nonpareil No. 5.
 Fonts of 10 feet, 3 lbs.
 Price, \$4.80.

Labor-Saving Brass Rule.

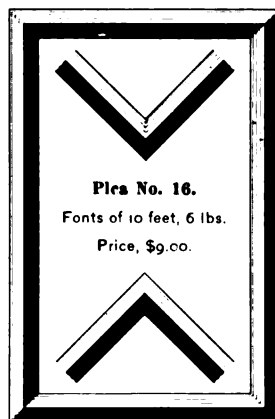
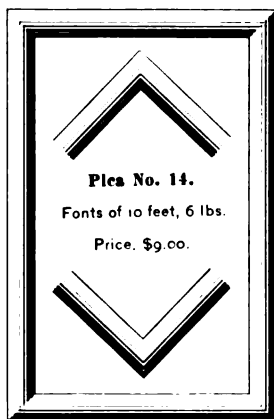
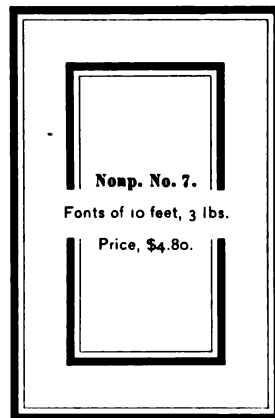
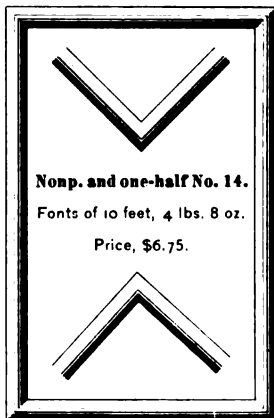
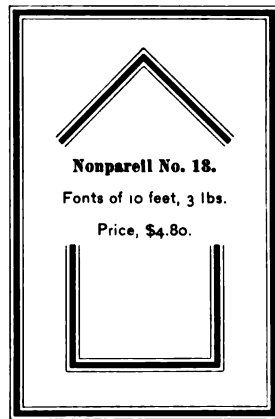
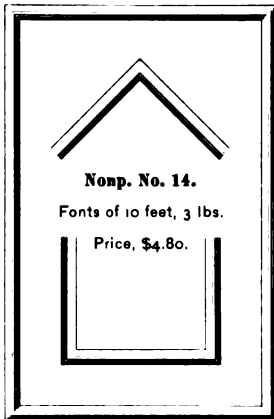

BRASS DASHES.

Cut to any length.

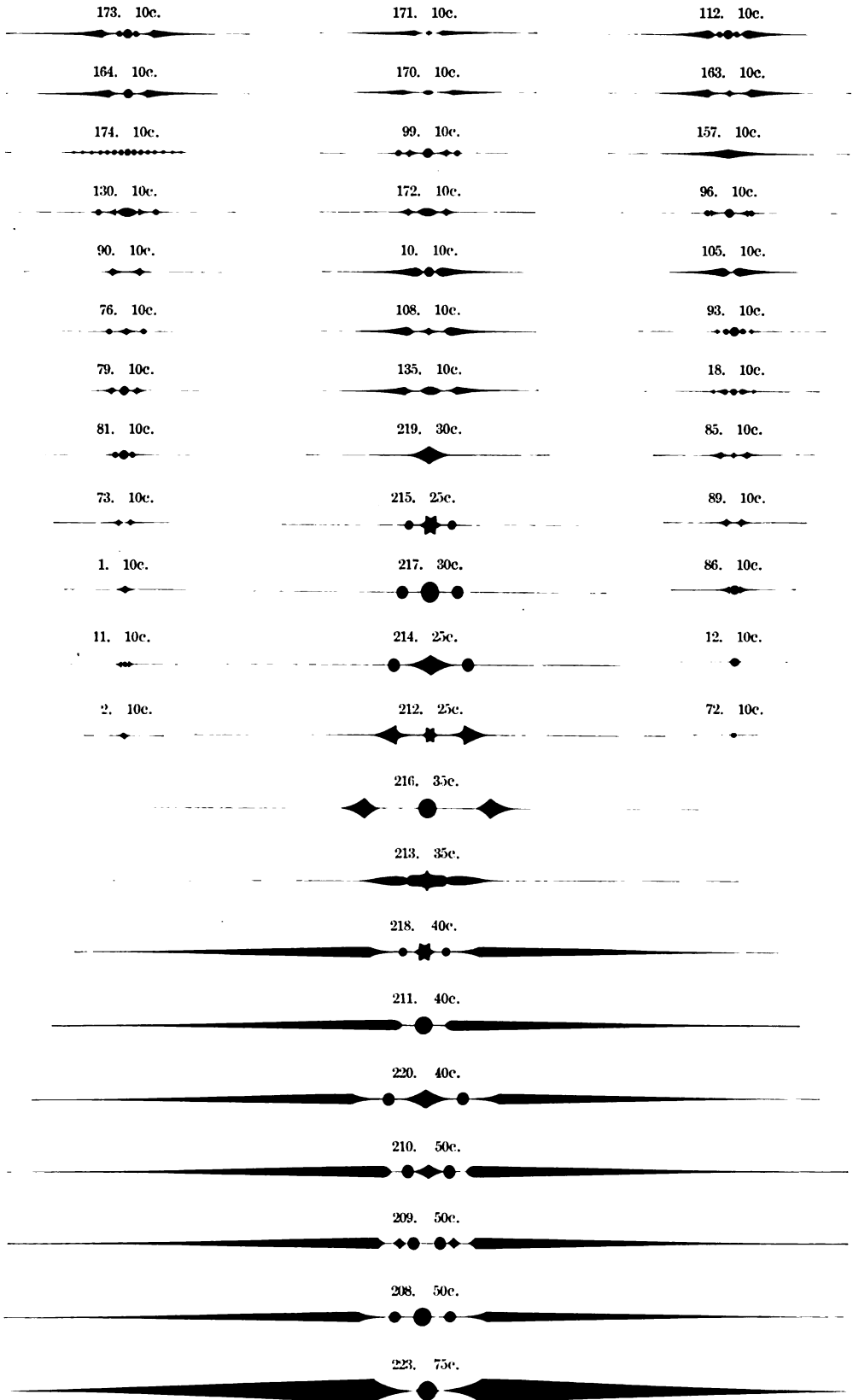

BRASS BRACES.

Complete set, \$5.60.

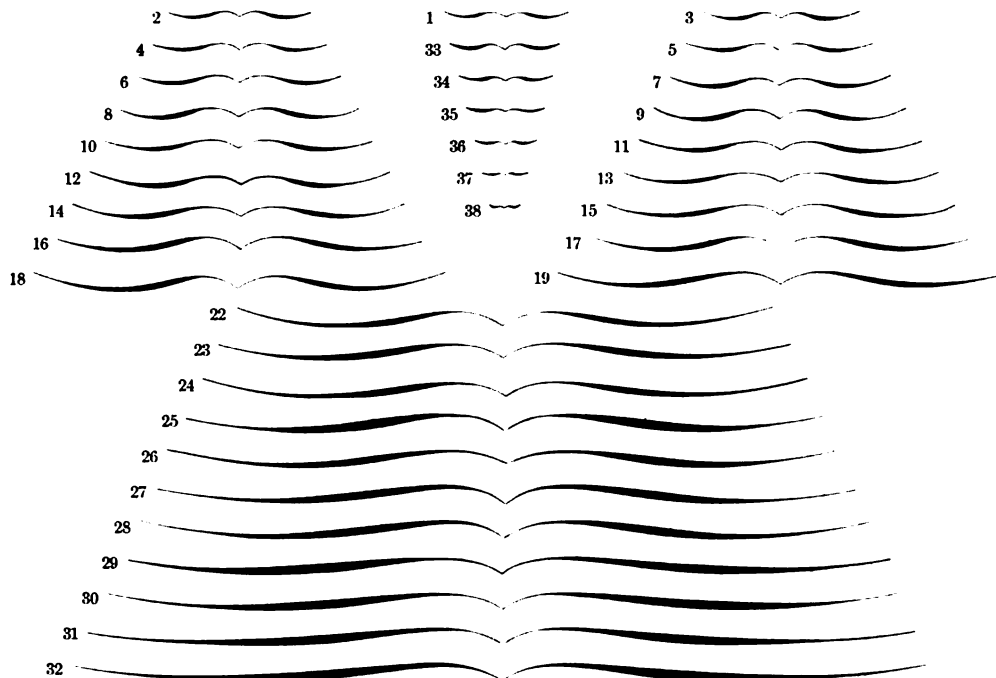

Prices.—Nos. 1-10, 12 cts. each; Nos. 11-17, 15 cts. each; Nos. 18-22, 18 cts. each; Nos. 23-27, 25 cts. each;
Nos. 28-32, 30 cts. each; Nos. 33-38, 12 cts. each.

BRASS OVALS AND CIRCLES.

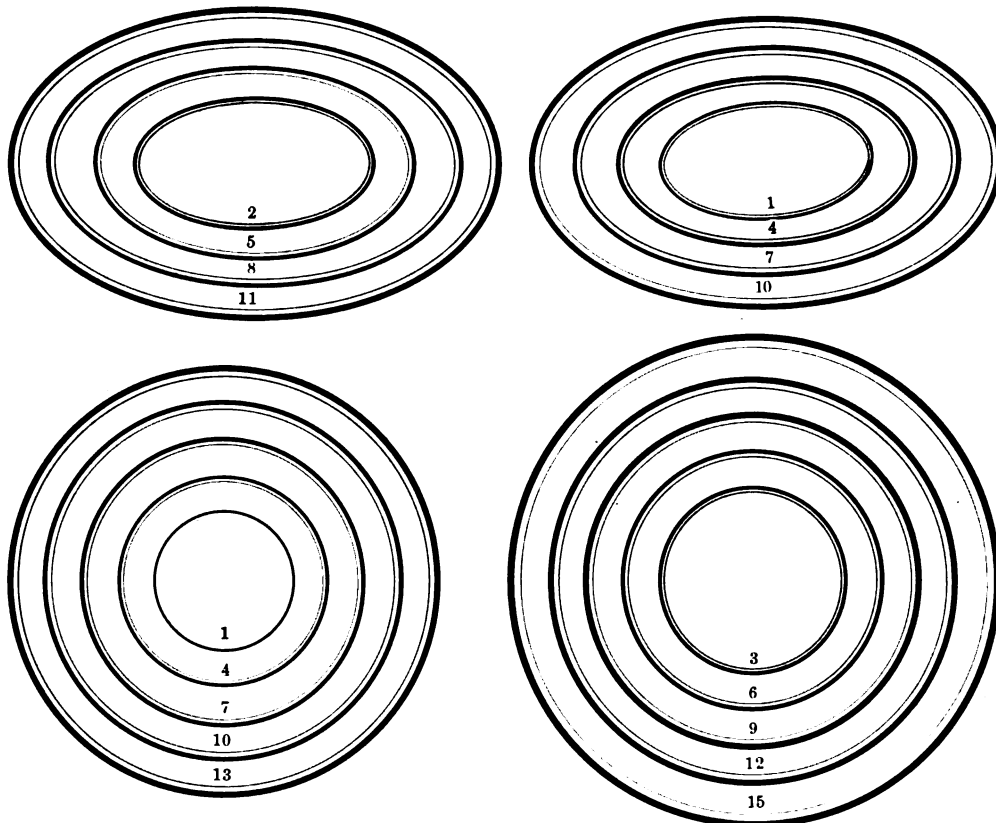

Prices of Ovals.—Nos. 1-6, 90 cts. each; Nos. 7-12, \$1.00 each; Nos. 13-15, \$1.25 each.
Prices of Circles.—Nos. 1-6, 60 cts. each; Nos. 7-11, 75 cts. each. Larger Ovals and Circles furnished to order.

BRASS CURVES AND CLAMPS.

Fonts of 170 Pieces. Price, \$8.00.

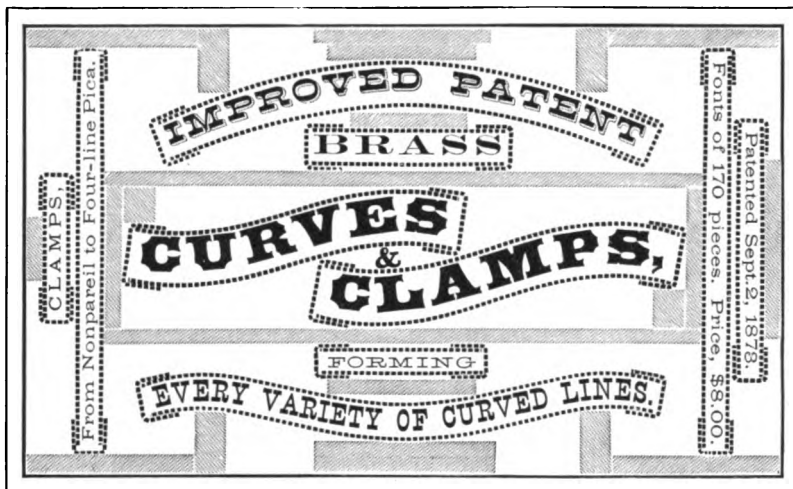

We here exhibit the complete construction of a form containing straight and bent lines. It is intended to illustrate the use of our NEW IMPROVED PATENT BRASS CURVES AND CLAMPS. They are indicated by hyphen rule, and are made to hold lines of any shape and body firmly. The Clamps match nonpareil, brevier, long primer, pica, three-line nonpareil, paragon, double pica, five-line nonpareil, three-line pica, seven-line nonpareil and four-line pica, and are marked to designate body. Intermediate sizes may be readily adjusted; for instance, bourgeois can be clamped with long primer clamps in connection with a twelve to pica (one point) lead, in order to make up for smaller body. They can be used in connection with six to pica leads, enabling the printer to produce every possible variation of curved or straight lines. Lines clamped in this way occupy scarcely any additional space, can never be thrown off their feet, and save a great amount of justification. All the reglets and quads required to lock up those ten lines in our little job are shown in print, in order to prove these facts.

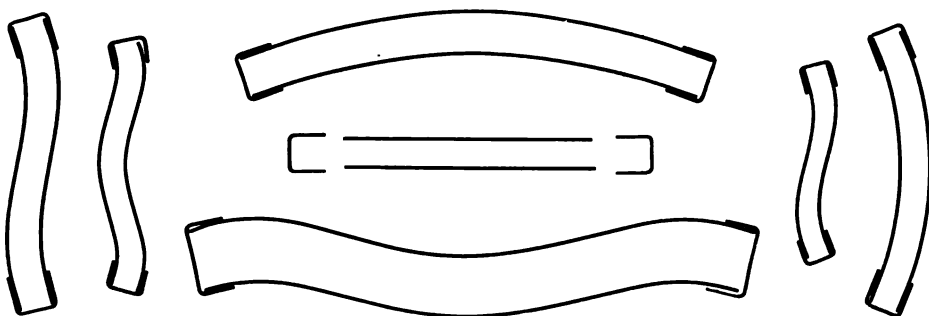

BRASS LEADERS.

Price per pound.

Six to pica	\$2 00
Three to pica	1 75
Nonpareil	1 60

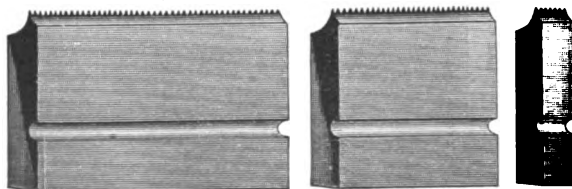

Price per pound.

Brevier	\$1 60
Long Primer	1 50
Pica	1 50

A very important item in blank work, having the face of fine dotted rule on bodies from six to pica upward. They are made to line with any face, and are cut in labor-saving lengths from one to eighteen ems pica.

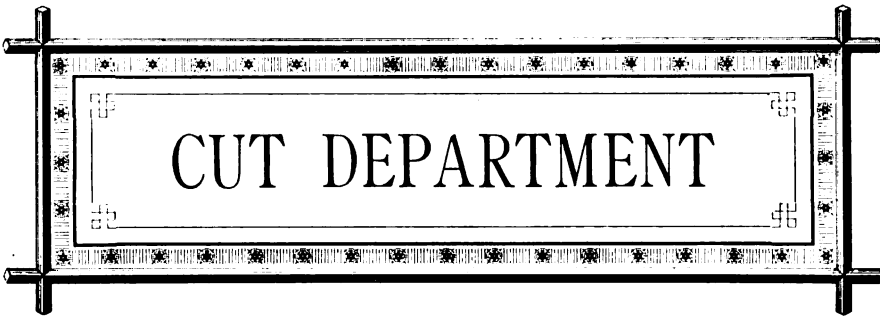



CUTS AND SMALL ORDERS.



CUTS are sent by mail pre-paid on receipt of list price. Many persons with whom we have no account order a ten-cent cut by postal card, saying they will pay on receipt. This entails postage on the bill, on the money and on the receipt, which, with the paper and ink wasted, cost more than the cut. Send money if you have no account with us and want us to fill small orders, which have the same attention here as large ones.

Cuts furnished from any specimen book. Give name of book and number of cut.



NEWSPAPER CUTS.

Price, 5 cents each.

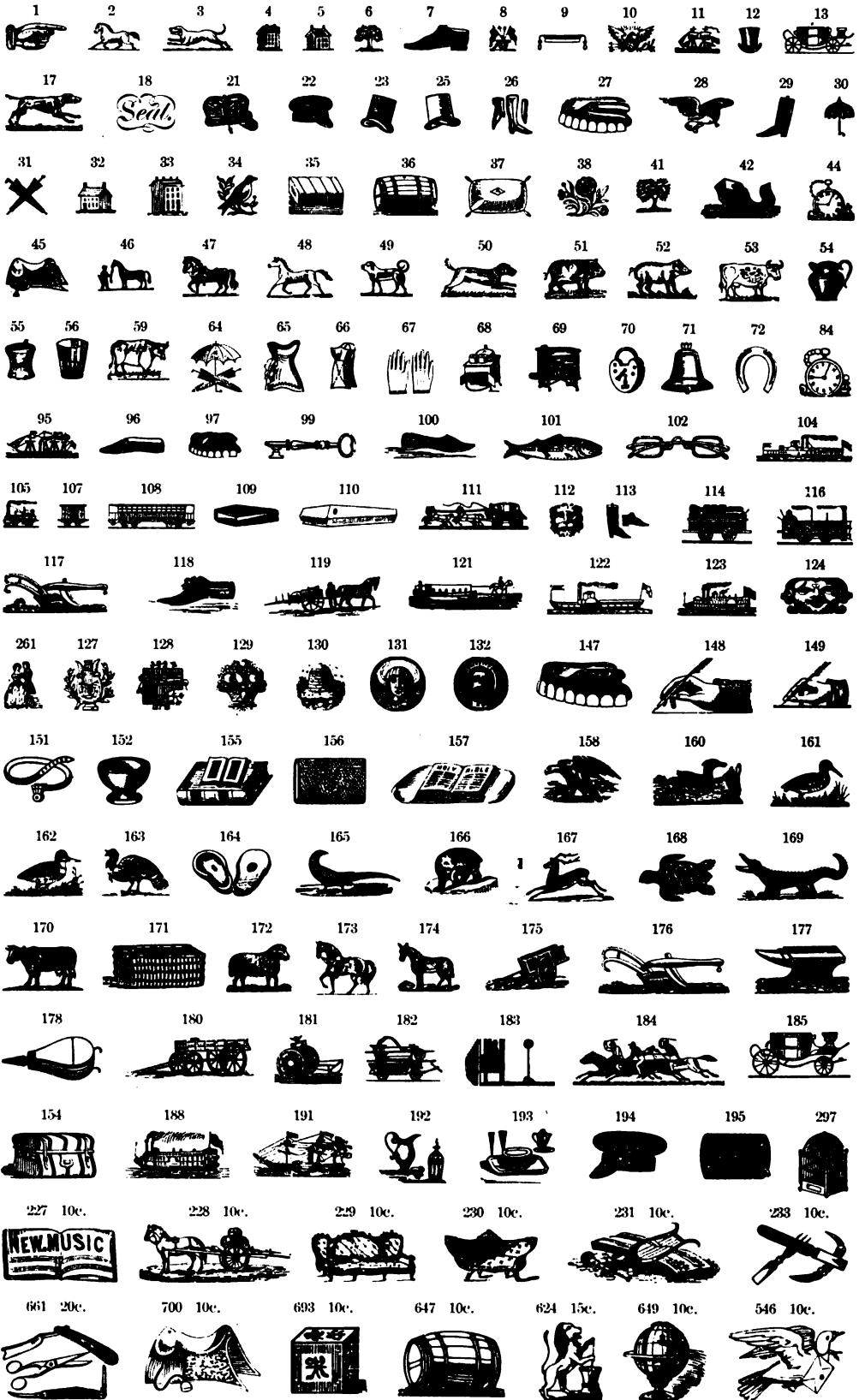

Trade Cuts.

1239 50c.



1244 50c.



1240 50c.



1245 50c.



1241 50c.



1246 50c.



1242 50c.



1247 50c.



1243 50c.



1248 50c.



1249 50c.



1259 50c.



1250 50c.



1260 50c.



1251 50c.



1261 50c.



1252 50c.



1262 50c.

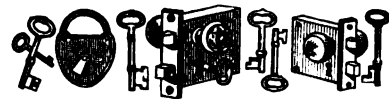

1253 50c.



1263 50c.



Trade Cuts.

1254 50c.



1264 50c.



1255 50c.



1265 50c.



1256 50c.



1266 50c.



1257 50c.

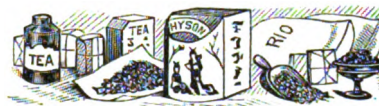

1267 50c.



1258 50c.



1268 50c.



1259 75c.

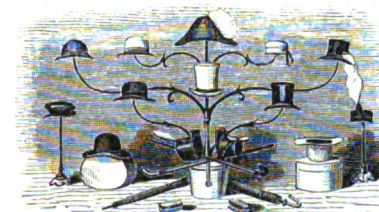

1210 75c.

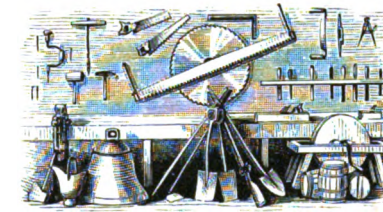

1544 75c.

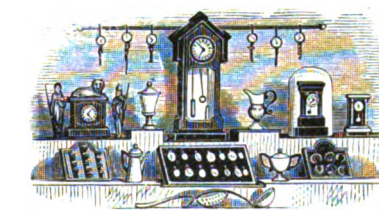

1206 75c.

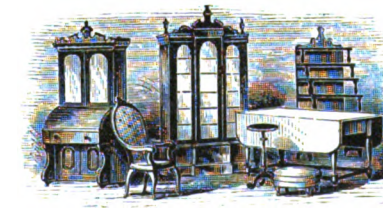

1205 75c.

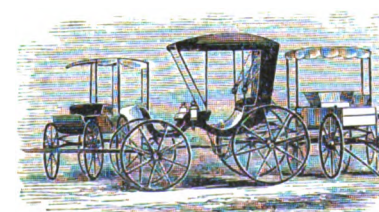

1219 75c.

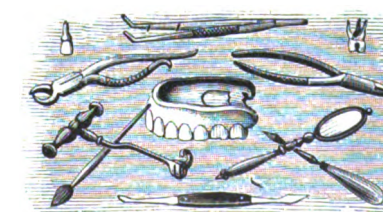

New Trade Cuts.

2203 75c.



2204 75c.



2205 75c.



2206 75c.

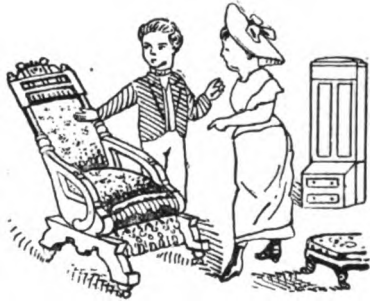

2207 75c.

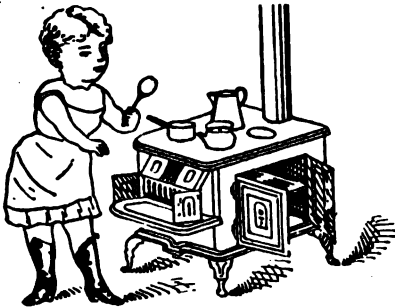

2208 75c.

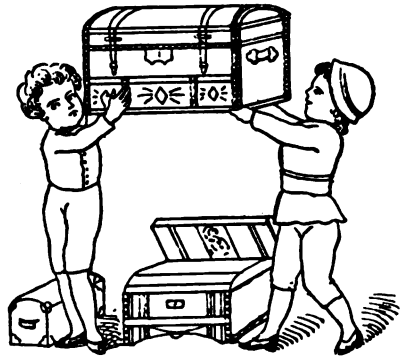

2209 75c.

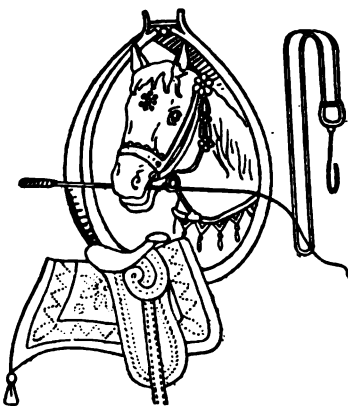

2210 75c.



New Trade Cuts.

2211 75c.

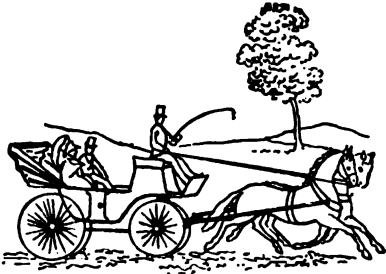

2212 75c.



2213 75c.



2214 75c.



2215 75c.



2216 75c.



2217 75c.



2218 75c.



Department Headings.

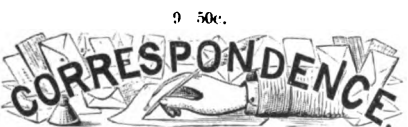
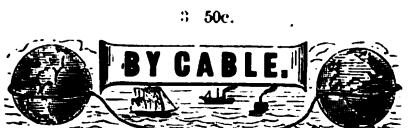

10 50c.

Correspondence.

21 50c.

HUMOROUS.

11 50c.

Agricultural.

22 50c.

Telegraphic.



Department Headings.

24 50c.



29 50c.



25 50c.



30 50c.



26 50c.



31 50c.



27 50c.



32 50c.



28 50c.



33 50c.



34 50c.



38 50c.



35 50c.



39 50c.



36 50c.



40 50c.



37 50c.



41 50c.



Almanac Headings.

2109. 50c.



2115. 50c.



2110. 50c



2116. 50c.



2111. 50c



2117. 50c.



2112. 50c.



2118. 50c.



2113. 50c.



2119. 50c.



2114. 50c.

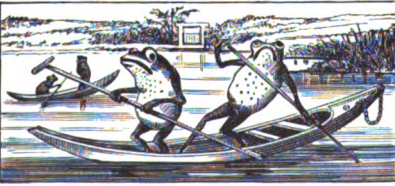

2120. 50c.



PRINTERS' COAT-OF-ARMS.

1875 \$1.00.



1874 60c.



1876. \$1.50



1870 20c.



1871 25c.



1872 40c.



1873 50c.



1877 \$2.00.



CARD LOGOTYPES.

In fonts of 108 pieces. Price, \$3.00.

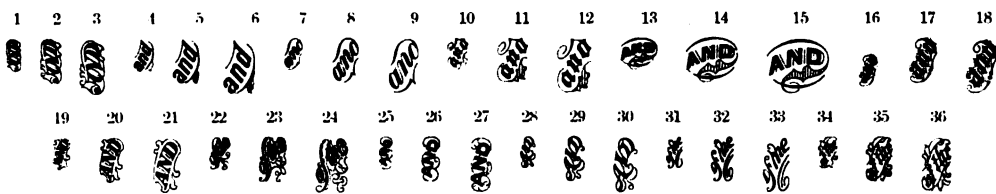

BILL-HEAD LOGOTYPES.



BILL-HEAD LOGOTYPES.



1843 50c.



1649 50c.



1842 30c.



1654 25c.



1653 30c.



1857 65c.



1548 75c.



1861 75c.



1546 75c.



1530 50c.



1547 75c.



1833 \$1.00.



1648 75c.



1858 75c.



1864 90c.



1650 60c. per pair.

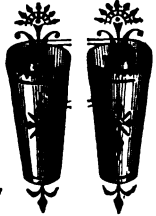

1549 40c.



1554 30c.



1553 30c.



2147 20c.



1558 75c.



1551 40c.



1562 75c.



1555 75c.

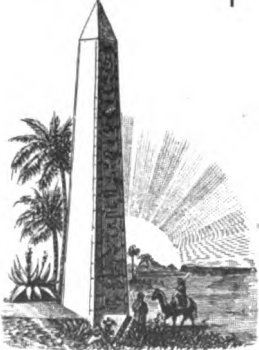

1556 90c.



1866 \$1.25.



1552 35c.



1846 40c.



1845 50c.



1856 75c.



1849 65c.



1850 \$1.00.



1844 40c.



1561 75c.



1851 60c.



1550 35c.



1852 65c.



1860 \$1.25.



1557 90c.



1847 50c.



1848 50c.



1867 \$1.00.



1868. \$1.25



1854 \$1.00.



CHECK BLANKS.

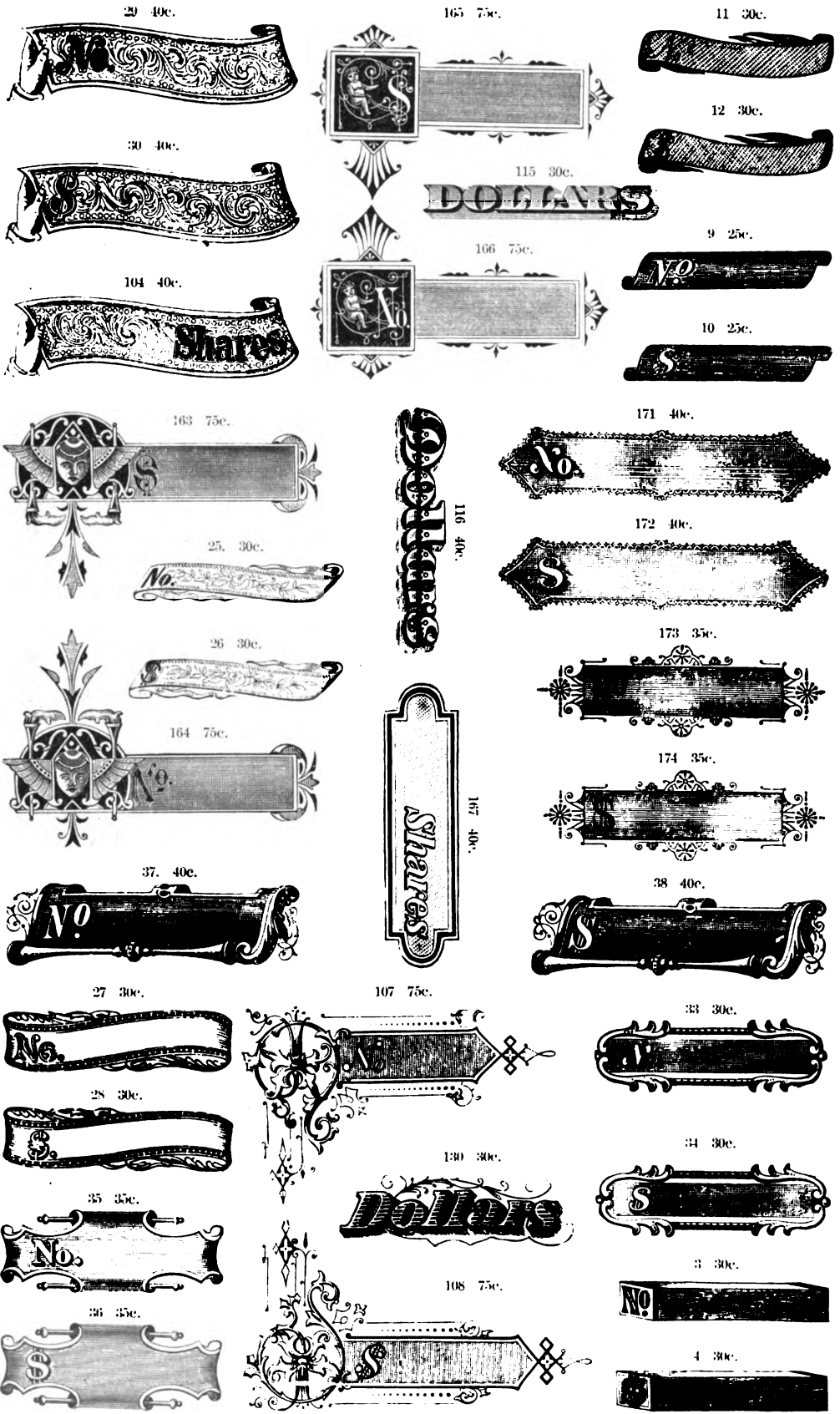

CHECK BLANKS.

13 30c.



19 30c.



15 35c.



14 30c.



20 30c.



16 35c.



31 35c.



101 40c.



17 30c.



32 35c.

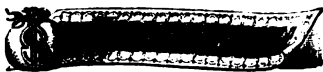

18 30c.



23 35c.



102 40c.



21 30c.



24 35c.



22 30c.



43 35c.



1 30c.



41 35c.



168 35c.



2 30c.



160 35c.

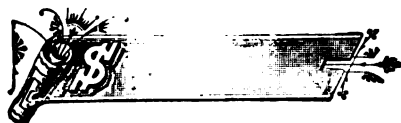

41 35c.



170 35c.



42 35c.

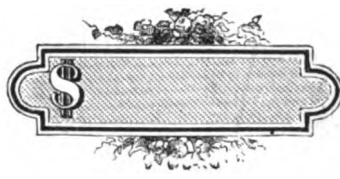

117 35c.



103 40c.



118 35c.



128 50c.



129 50c.



1495 30c.



1496 15c.



1497 15c.



1498 15c.



1499 15c.



1500 25c.



1501 15c.



1502 15c.



1503 15c.



1504 15c.



1505 15c.



1506 15c.



1507 15c.



1508 15c.



1509 20c.



1490 25c.



1510 30c.



1511 25c.



1512 25c.



1513 30c.



870 \$1.00.



844 \$1.00.



845 \$1.00.



824 \$1.00.



837 \$1.00.



834 \$1.00.



843 \$1.00.



842 \$1.00.



838 \$1.00.



841 \$1.00.



839 \$1.00.





2145 50c.

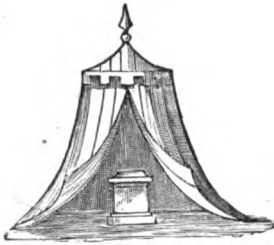

2144 30c.

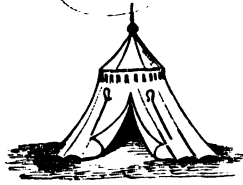

578 50c



1317 60c.



1485 \$1.00.

580 75c.



589 60c.



2133 60c.



591 \$1.00

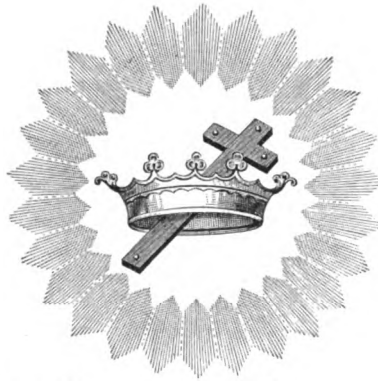

1474 60c.



1318 \$1.25.

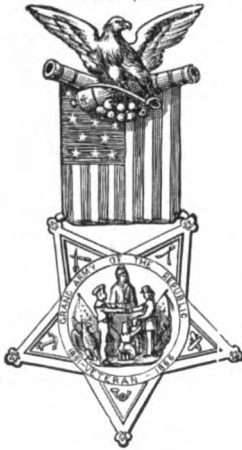

2135 75c.



2137 75c.



2132 75c.



2134 75c.

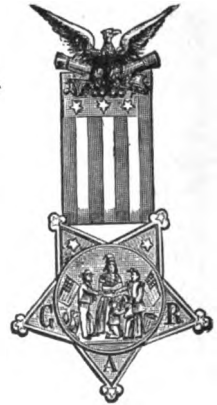

588 \$1.00.



569 60c.



1315 75c.

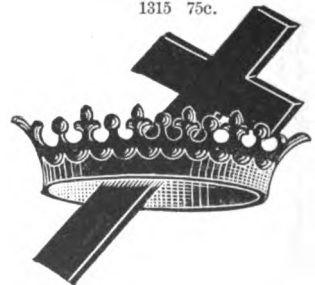

2148 30c.



1316 75c.



561 40c.



925 30c.



2149 40c.



1314 40c.



559 40c.



2151 40c.



2150 30c.



2152 25c.



570 40c.



1352 \$1.00.



1153 \$1.00.

1827 \$1.00.

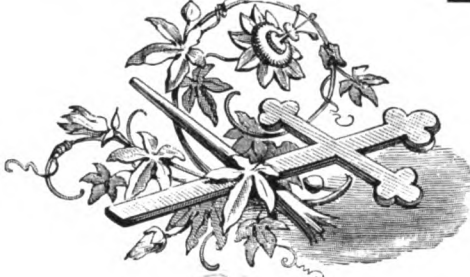

1156 \$1.00.

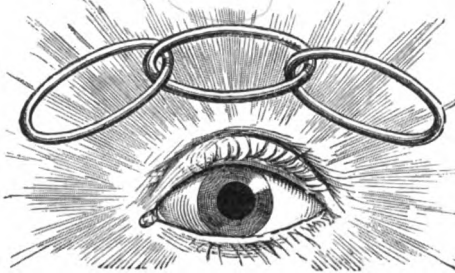

2153 25c.

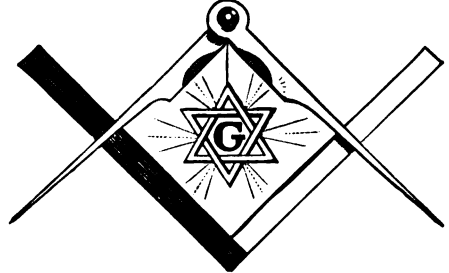

1066 50c.



1319 \$1.50.

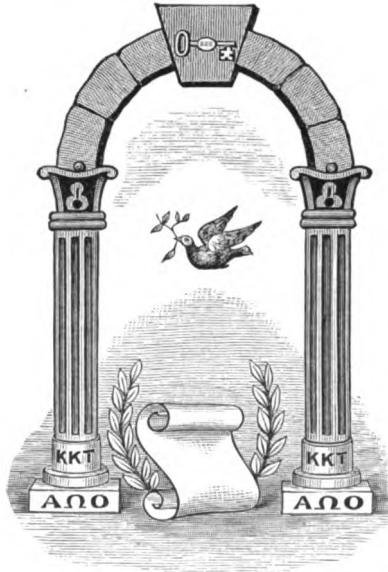

2142 40c.



659 75c.



1825 75c.



CARD SCROLLS.

971 40c.



1444 50c.



1450 50c.



964 50c.



981 50c.



966 50c.



967 50c.



963 50c.



969 50c.



1086 50c.



979 50c.



1455 50c.



965 50c.



568 60c.



1447 50c.



1433 60c.



977 40c.



1460 50c.



938 60c.



565 60c.



1489 60c.



974 40c.



566 60c.



CARD SCROLLS.



1457. 50c.



1451. 50c.

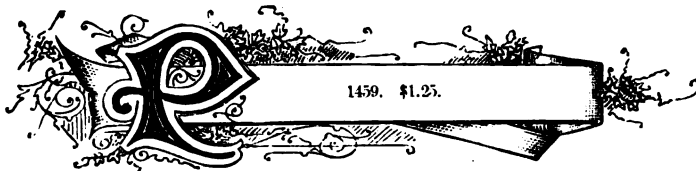
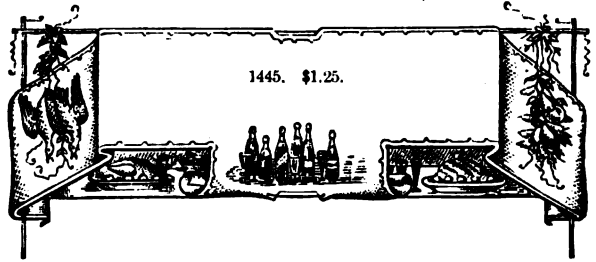
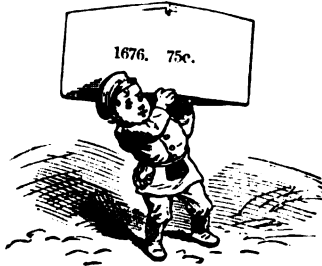

1682. 40c.

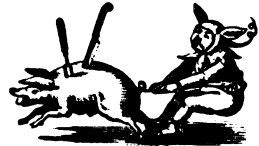

1461. \$1.00.



1452. 75c.



1456. 60c.

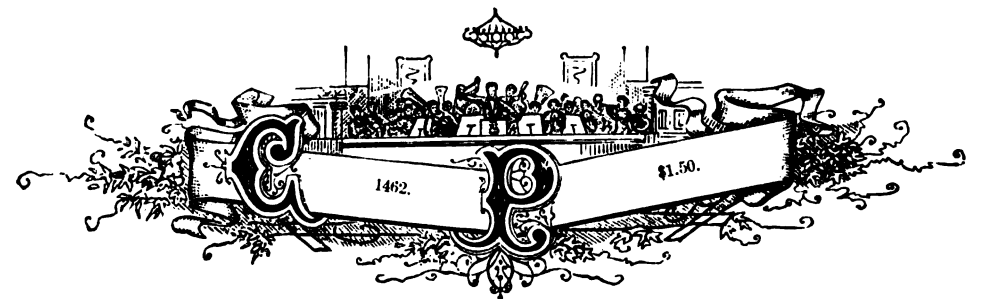

1655 40c.



1671 40c.



1683 40c.



1657 40c.



1661 40c.



1660 40c.



1659 40c.



1666 40c.



1678 40c.



1663. 75c.



1684. 75c.

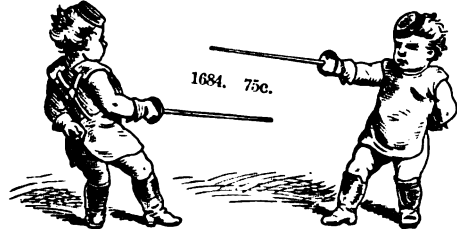

1712 75c.

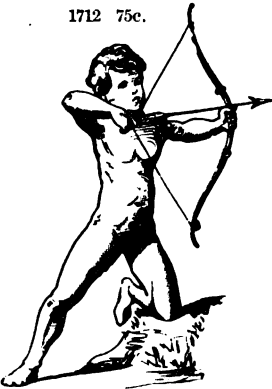

1731.



\$1.00.

1713. 75c.



1665 60c.



1670 60c.



1664 60c.



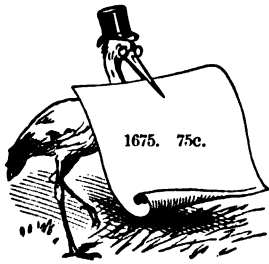

1675. 75c.

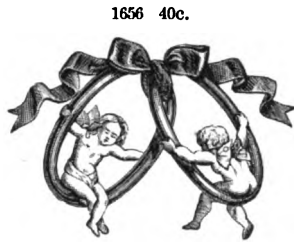

1656 40c.



1658 40c.



1662 40c.



1345 50c.



1667 40c.



1695. 50c.



1296 30c.



1669 50c.



1730. 75c.



1714 \$1.00.

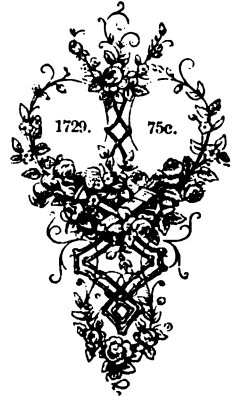

1729. 75c.



1677. 60c.



1700 40c



1668 50c.

1655 40c.



1671 40c.



1683 40c.



1657 40c.



1661 40c.



1660 40c.



1659 40c.



1666 40c.



1678 40c.



1663. 75c.



1684. 75c.

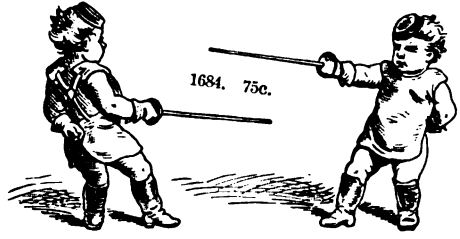

1712 75c.

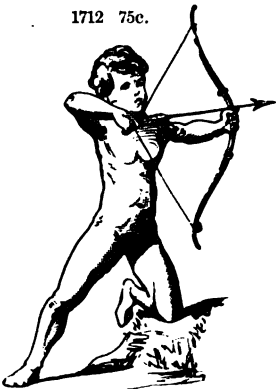

1713. 75c.



1731.

\$1.00.



1665 60c.



1670 60c



1664 60c.



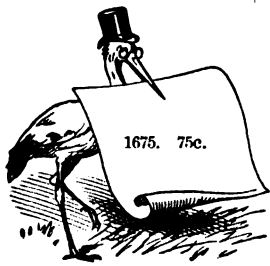

1656 40c.



1658 40c.



1345 50c.

1662 40c.



1667 40c.



1695. 50c.



1296 30c.



1669 50c.



1714 \$1.00.



1677. 60c.



1700 40c



1668 50c.



638 30c.



568 50c.



1821 75c.

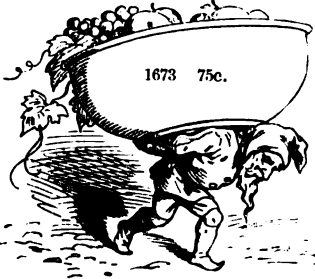

1673 75c.

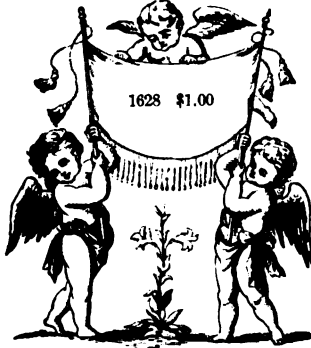

1628 \$1.00



1822 75c.

1719 75c.



1723 \$1.00.



1718 75c.



1725 \$1.00.

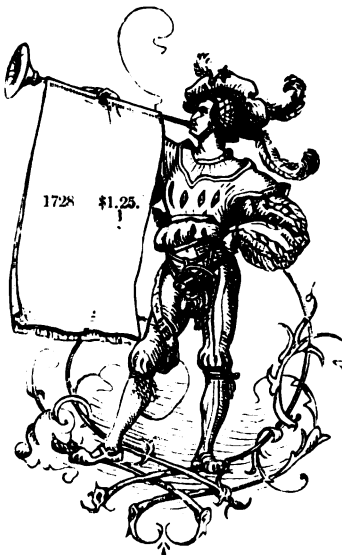

1728 \$1.25.

1727 \$1.00.



1708 40c.



690 \$1.00.

1768 25c



293 10c.



1336 25c.



611 30c.



1789 25c.



1652 30c.



1790 25c.



1701 40c.



124 5c.



261 5c.



696 \$1.00.



1098 \$1.00.



1785 25c.



760 15c.



1342 40c.



1688, 40c



1689 40c.



1690 40c.



1343 40c.



1339 30c.



1340 30c.



1338 40c.



702 40c.



703 40c.



1341 40c.



1724 \$1.00.

2154 40c.

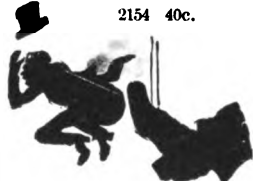

2156 75c.



2155 40c.



1706 75c.



763 15c.



762 15c.



634 20c.



632 20c.



787 30c.



1702. 40c.



1680 40c



1681. 40c.



631 50c.



633 \$1.00.



1355 40c.

1814 25c.



1679. 40c.



739 15c.



1716 \$1.00.



1709 40c.

682 40c.



1707 50c.



1337 40c.



1708 50c.



1721. \$1.00



1720 \$1.00



776 50c.



779 50c.



778 50c.



774 50c.



773 50c.



617 40c.



1807 25c.



1699 50c.



786 25c.



640 40c.



1710 40c.



1781 25c.



1704. 40c.



1779 25c.



775 50c.



1788 25c.



1782 25c.



785 40c.



1698 \$1.00.



777 40c.



1762 25c.



1763 25c.



1726 \$1.50.



1722



75c.

1786 25c.



1780 25c.



1803 25c.



1784 25c.



1765 25c.



1787 25c.



1688 50c.



1517 40c.



625 40c.



1694 50c.



1686 50c.



612 75c.



616 75c.



1472 75c.

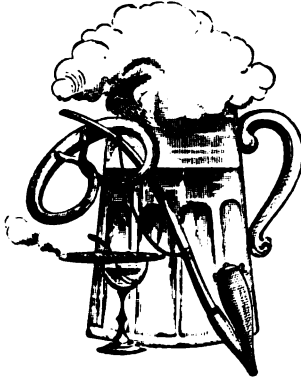

1473 \$1.00.



1715 \$1.00.



614 \$1.25.



1734 \$1.00.



1687 40c.



1692 40c.



1697 40c.



1691 40c.



607 30c.



621 40c.



1812 25c.



1755 25c.



1756 25c.



623 30c.



1705 75c.



734 15c.



1733.

75c.

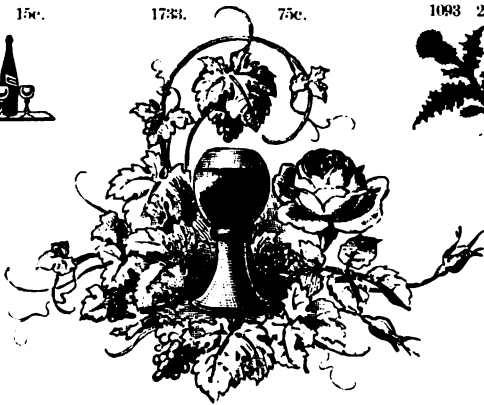

1093 20c.



609 30c.



1097 25c.



610 30c.



608 30c.



448 75c.

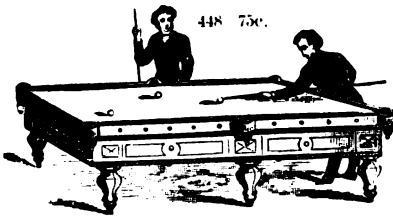

1811 25c.



678 40c.



449 30c.



659 75c.

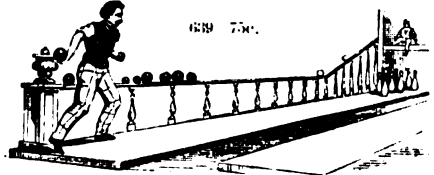

1476 \$1.00.



1783 25c.



1685 50c.



1686 50c.



1784 25c.



1739 \$2.00.



Printers' Restaurant.

BILL OF FARE.

SOUP.

Nonpareil. Brevier. Bourgeois.
Long Primer. English.

ROAST.

Sheepsfoot, with Sauce. Roast Ribs, of Hand Press.
Chickenfoot, Rare.

BOILED.

Gauge Pins on Toast. Rubber and Felt Blankets.
Roller Composition, a la Van B.

ENTREES.

Modern Antique Pot Pie.
New Borders, with Brass Rule.
Embellishments, a la Word Scrolls.
New Celtics, with Card Ornaments.
Ionics, a la Francaise.
Pen Text, Gothics, Octics.

VEGETABLES.

Sliced Leads and Slugs.
Stewed Quoins, a la Hempel.
Potatoes Mashed on Ink Slab.
Bean Better Without.
Corn on Galley Rack.

PASTRY.

Pi, bought at 8 cts. per lb. Type Wash, Chicageese.
Chocolate Brown, a la Wiborg.

DESSERT.

Black, Green or Mixed Ink. Lye. Drinks at the Bar.

1740 75c.



Joinings are made at points marked A, B, C, D. with Brass Rule.

1737 \$2.00.



798 \$1.00.



817 \$1.00.



1738 \$1.75.

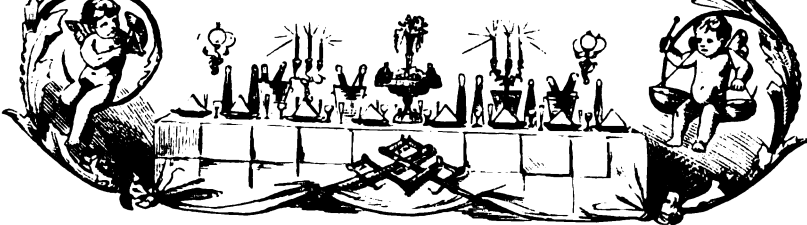

1742 \$2.00.

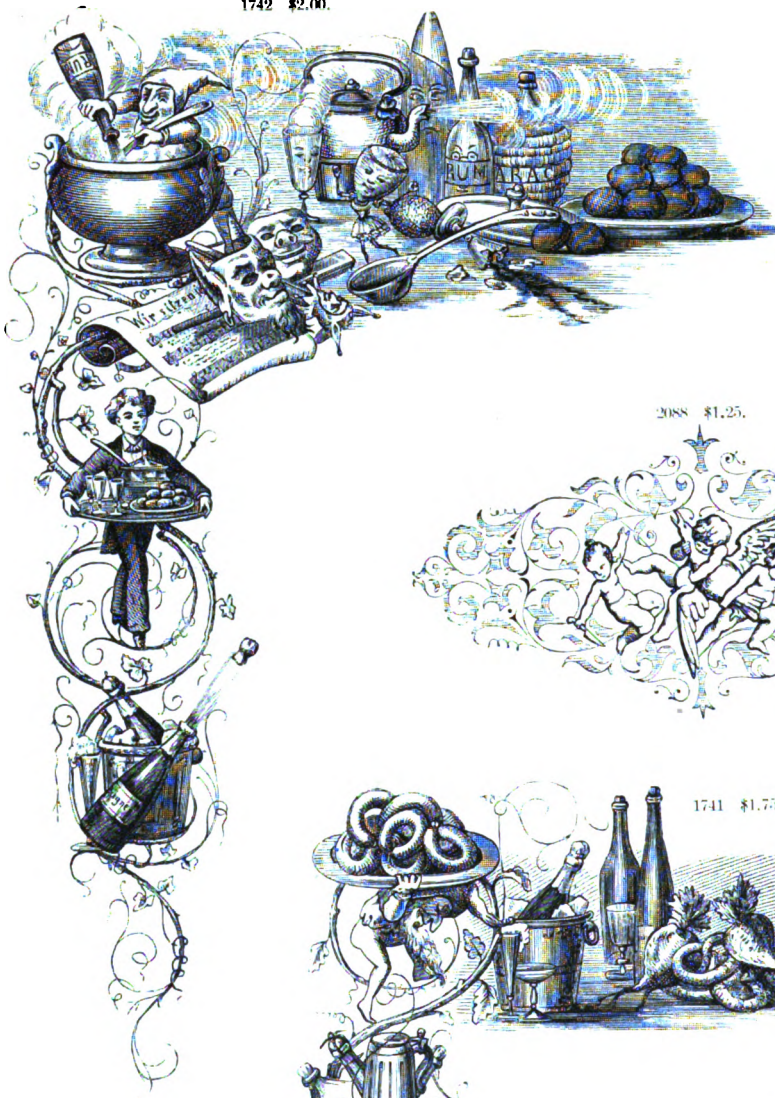

1560 50c.



2088 \$1.25.



1741 \$1.75.



2087 75c.

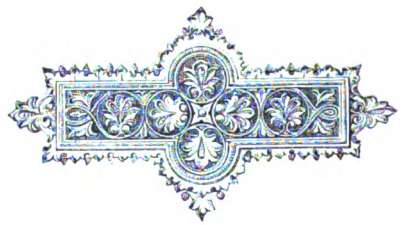

2012 75c.



809 \$1.25

Mortised.



.635 \$1.00.



803 \$1.00.



818 \$1.00.



794 \$1.00.



641 40c.

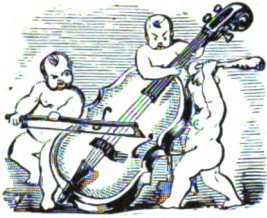

452 50c.

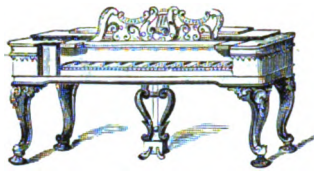

573 60c.



936 50c.



552 25c.



450 75c.

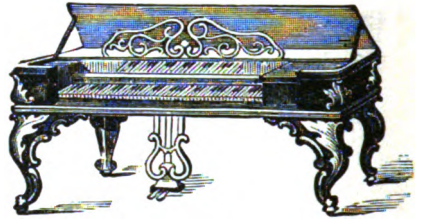

273 10c.



1207 75c.

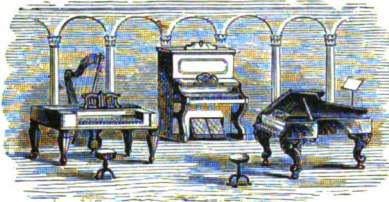

744 15c.



1212 75c.

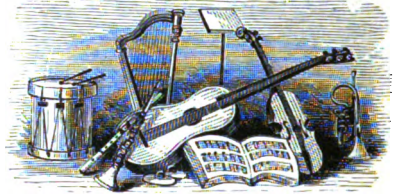

463 25c.



799 \$1.00.

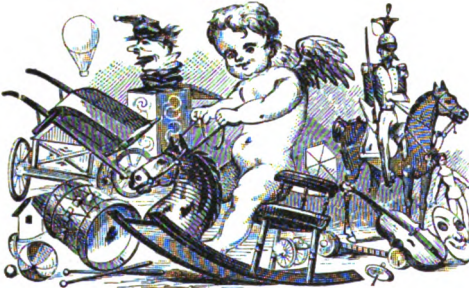

814 \$1.00.



1278 30c.



125 5c.



2171 50c.

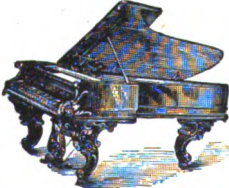

214 10c.



908 \$1.50.

Mortised.



749 15c.



810 \$1.00.

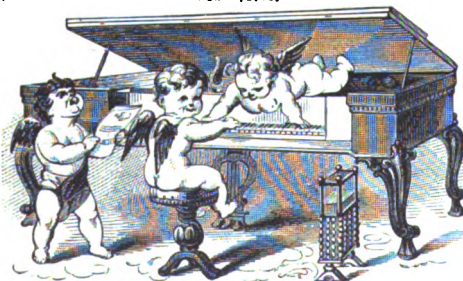

1143 \$1.00.

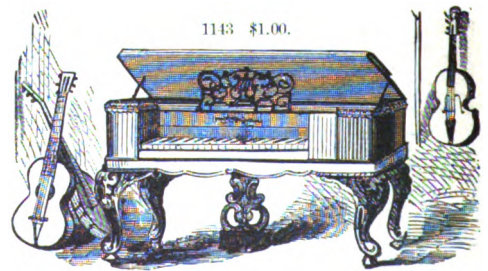

447 35c.



453 25c.



1033 50c.



455 25c.



451 35c.



465 20c.



464 40c.



742 25c.



461 35c.



457 \$1.00.

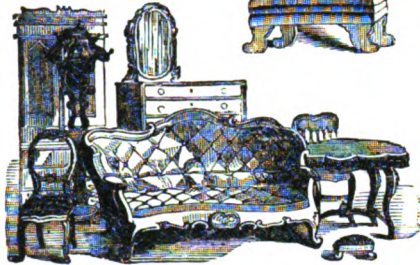

FURNITURE

736 15c.



1141 \$1.00.

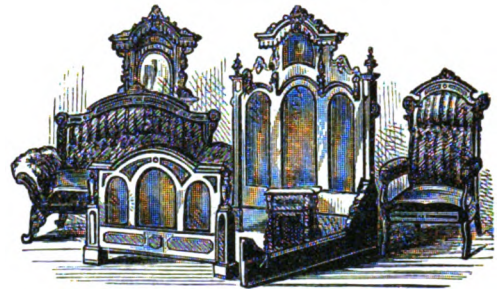

1064 75c.

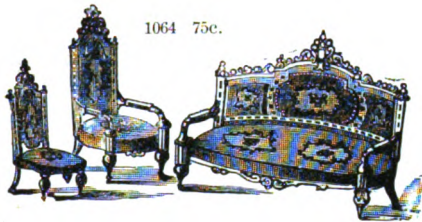

454 65c.



458 \$1.00

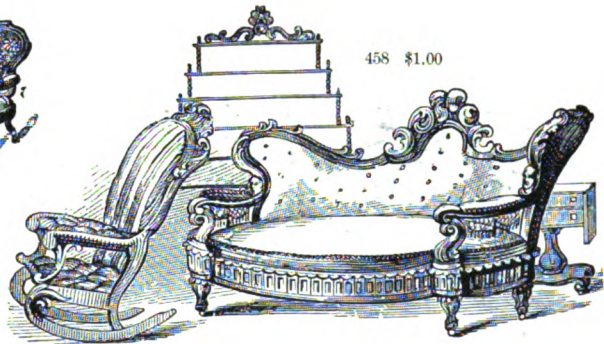

479 25c.

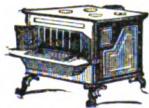

478 25c.

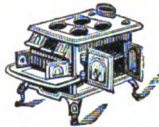

480 50c.

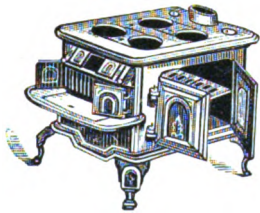

477 40c.

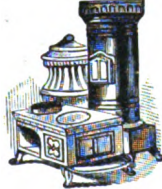

1215 75c.

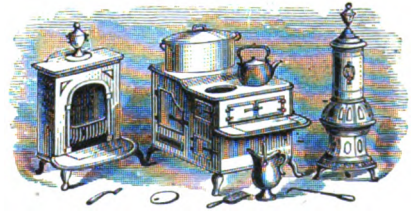

1279 \$1.00.

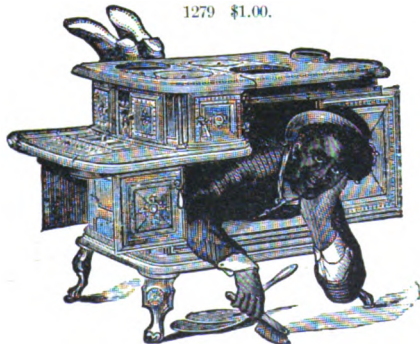

1142 \$1.00.

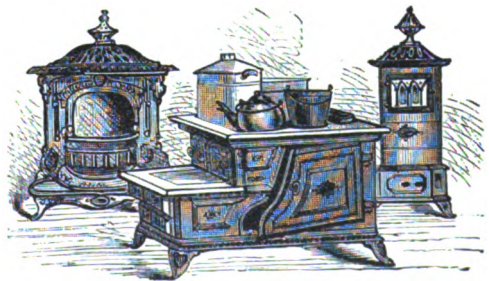

1285 \$1.00.



2160 \$1.00.

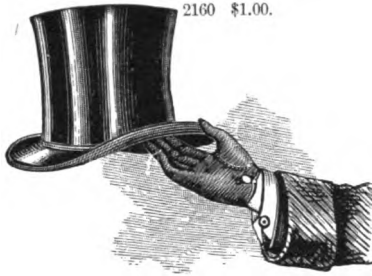

2161 75c.



2162 50c.

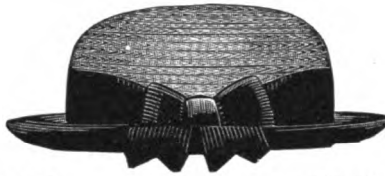

2167 75c.



1290 25c.



194 5c.



1289 20c.



2166 75c.



2165 60c.



1288] 40c.

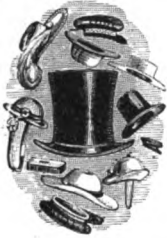

309 10c.



2164 60c.



2163 75c.

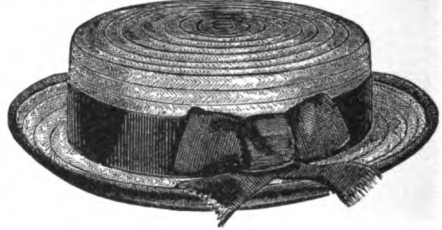

1292 \$1.50.



815 \$1.00.



1148 \$1.00.

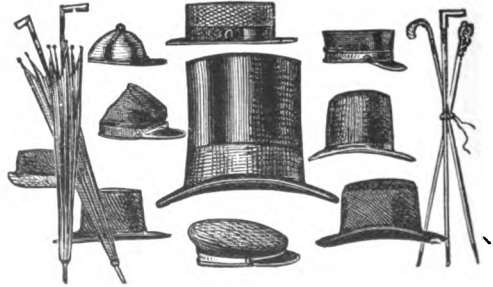

2168 50c.



753 25c.



113 5c.



1311 75c.

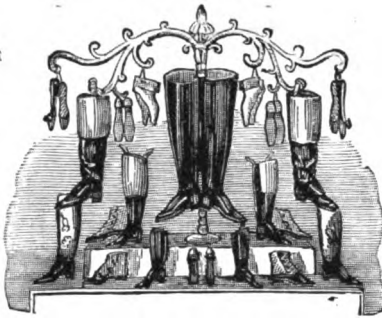

727 20c.



1269 50c.



221 10c.



1049 40c.



216 10c.



708 25c.



2169 30c.



709 30c.



223 10c.



707 60c.



1214 75c.



1631 \$1.00.



725 1c.



724 20c.



1272 65c.



804 \$1.00.

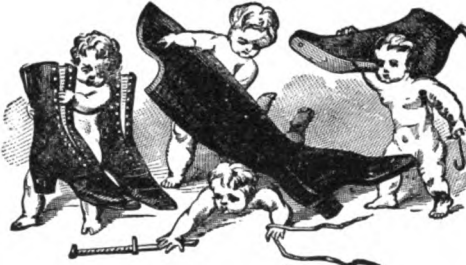

1270 60c.

2170 60c.



1463 50c.



726 20c.



270 10c.



1273 \$1.25.



1146 \$1.00.



1767 25c.



691 25c.



917 50c



695 25c.



730 18c.



1750 25c.



1223 75c.

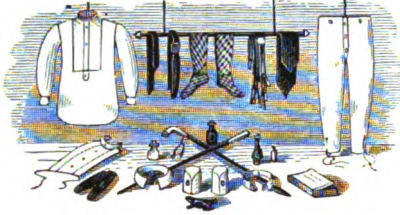

1227 75c.

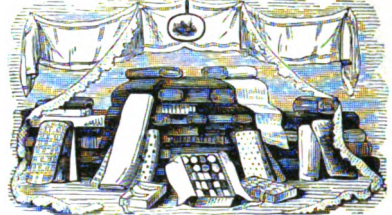

752 10c.



1119 \$1.00.

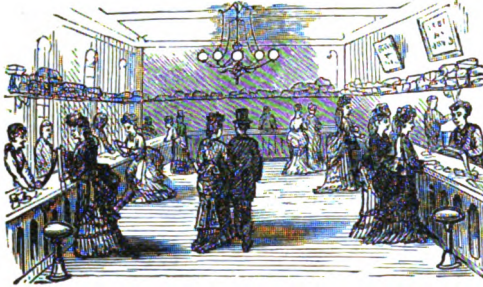

800 \$1.00.

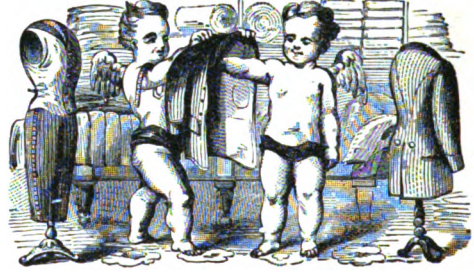

1220 75c.

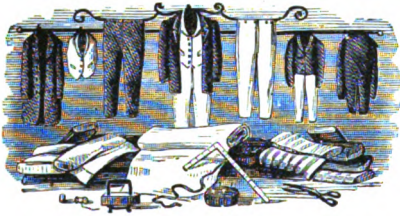

1291 50c.

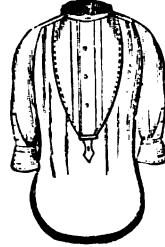

1200 75c.

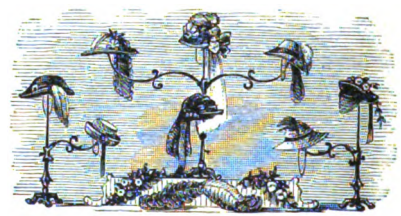

1108 \$1.00.

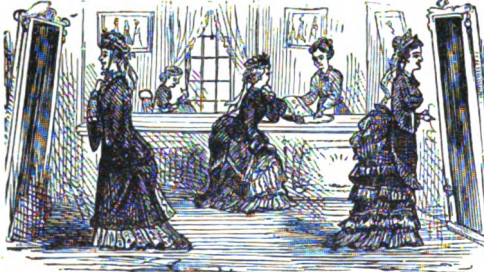

1107 \$1.00.



1106 \$1.00.



1104 \$1.00.

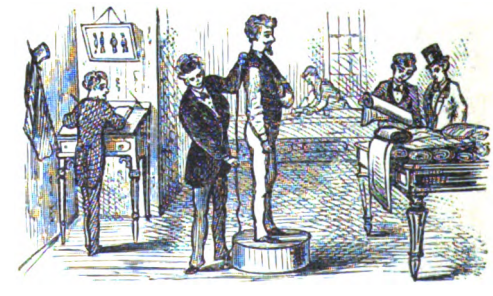



892 90c.



714 15c.

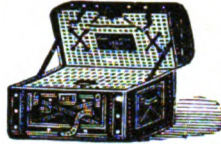

476 40c.



1626 50c.

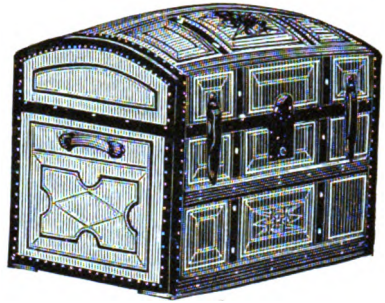

1630 \$1.00.



686 \$1.25

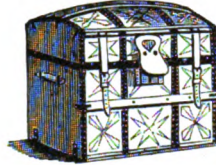

1281 40c.

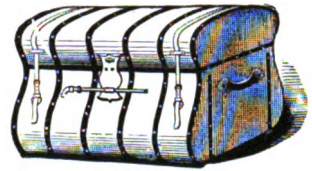

473 50c.

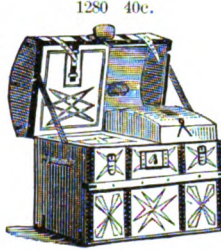

1280 40c.

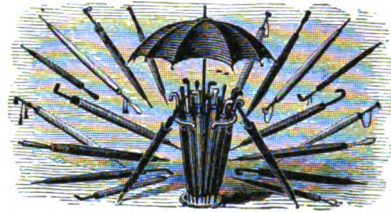

1222 75c.

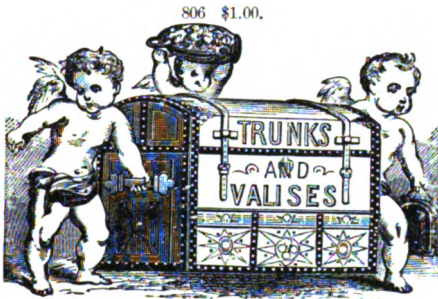

806 \$1.00.



64 5c.



31 5c.

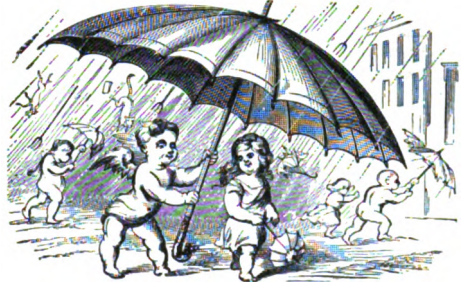

798 \$1.00.



881 \$1.50
Mortised.



705 50c.

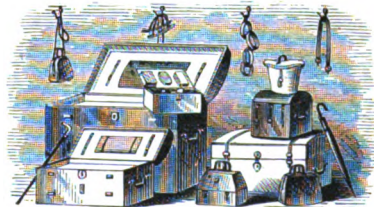

1213 75c.

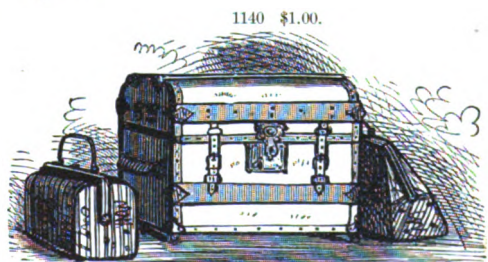

1140 \$1.00.

471 30c.



192 5c.



82 5c.



1597 50c.



460 10c.



474 60c.



83 5c.



193 5c.

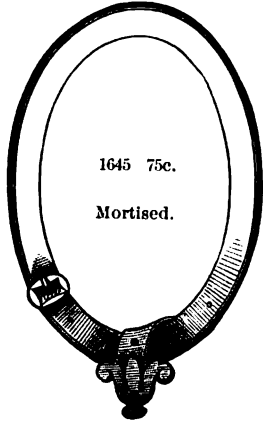

470 \$1.00

738 20c.



729 25c.



654 60c.



459 \$1.00.



746 10c.



745 10c.



456 75c.



1046 40c.



475 25c.



1595 \$1.00.

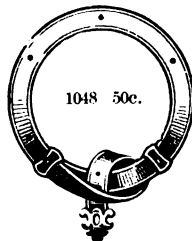

1598 50c.



1144 \$1.00.



809 \$1.00.





1284 \$1.00.

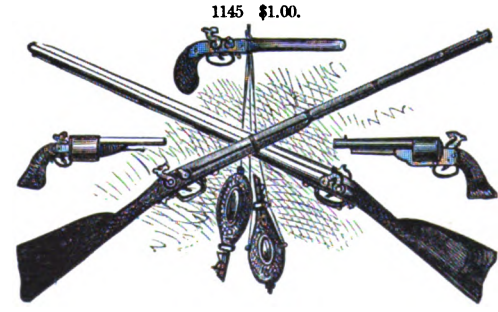
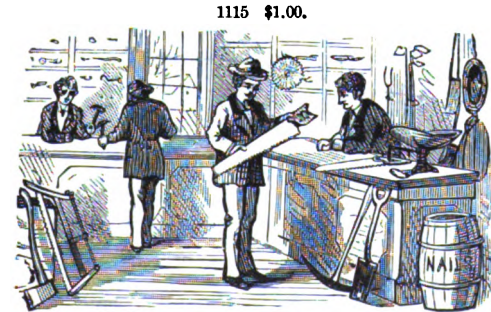
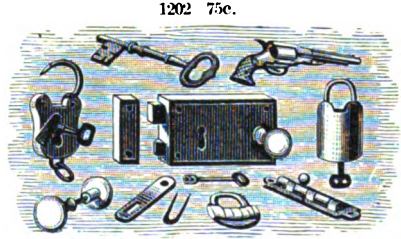
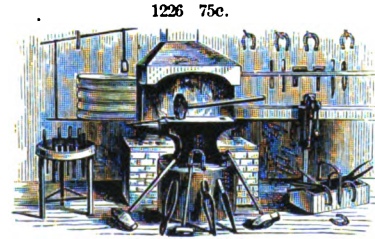
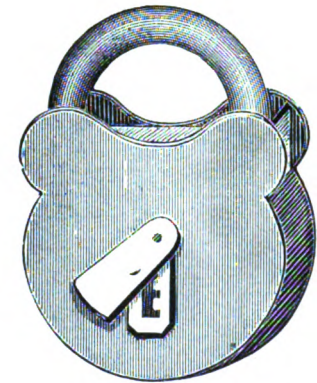
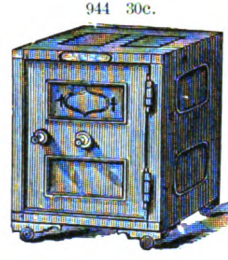
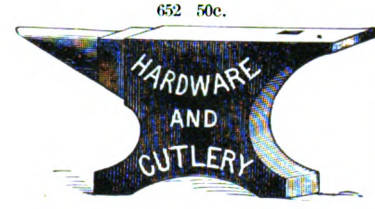
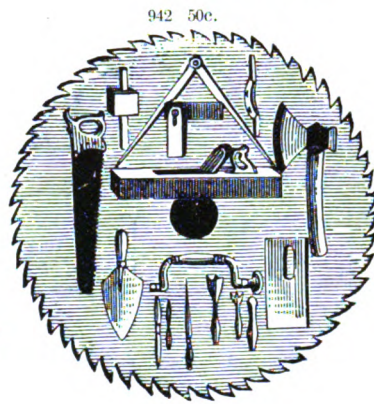
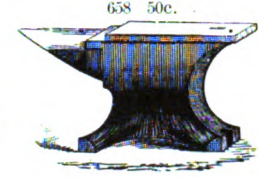
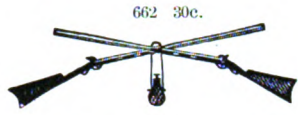
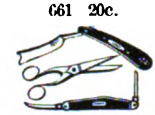

822 \$1.00.



1105 \$1.00



795 \$1.00.



650 \$1.25.

693 10c.



1200 75c.

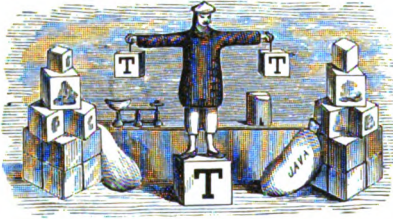

653 40c.



1257 50c.



918 \$1.50

Mortised.

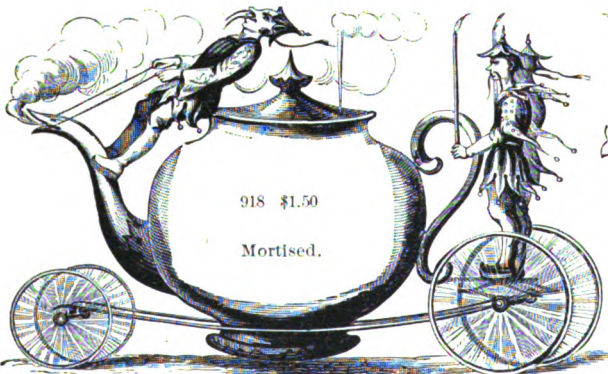

1234 75c.

Mortised.



1760 25c.



618. 30c.



628. 75c.



911 \$1.50

Mortised

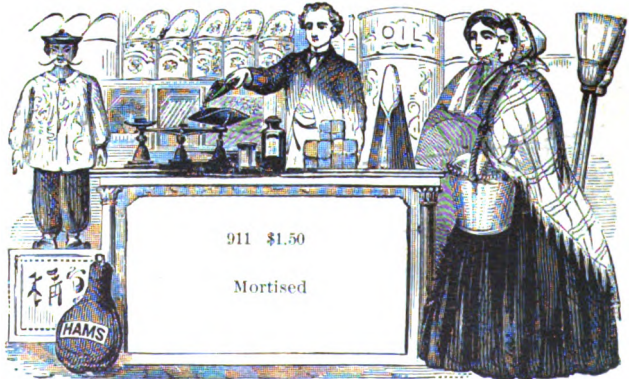

2172 50c.



796 \$1.00.

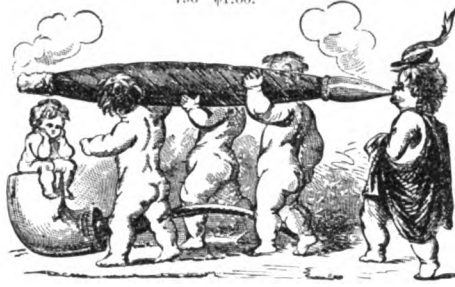

1320 60c.



679 40c.



1624 50c.



1307 \$1.00.

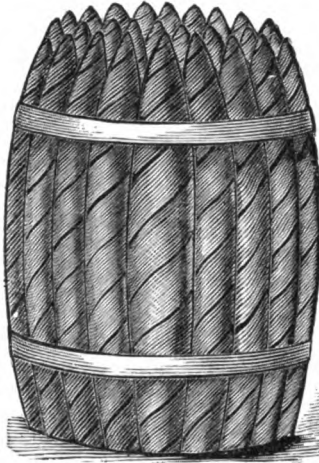

698 75c.



1308 50c.



732 20c.



680 40c.



1114 \$1.00.5



1309 \$1.25.



1538 25c.

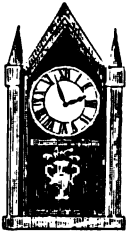

1540 25c.



1542 60c.



1537 25c.



1536 25c.



1535 25c.



295 10c.



1539 \$1.25.

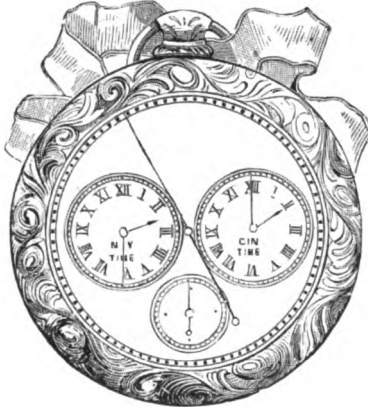

1533 40c.

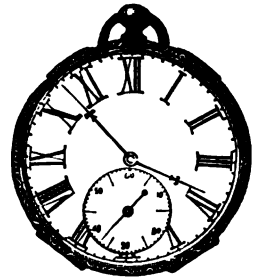

733 20c.



694 10c.



84 5c.



1532 30c.



720 20c.



1530 30c.

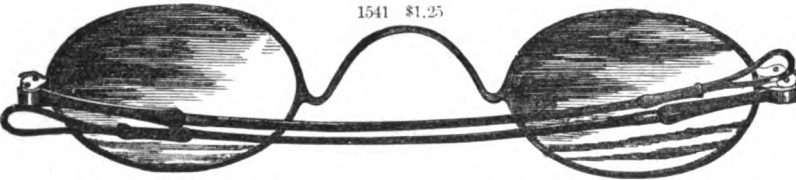

1541 \$1.25

1534 25c.



1531 \$1.00.

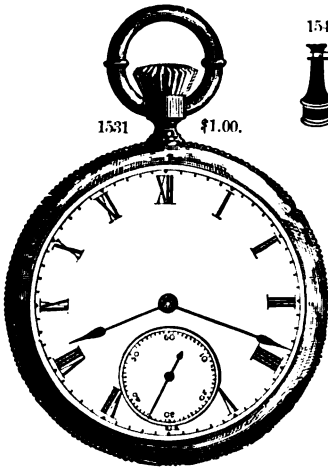

1543 20c.



1563 30c

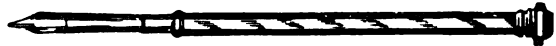

656 40c.



1545 \$1.00.



756 10c.



820 \$1.00.

808 \$1.00.

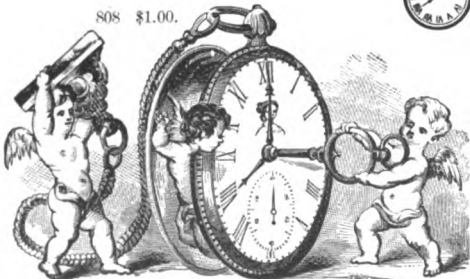

649 10c.



149 5c.



155 10c.



1295 25c.



156 5c.



148 10c.



232 10c.



227 10c.



699 10c.



298 10c.



264 10c.



277 10c.



1293 30c.



1600 50c.



917 75c.

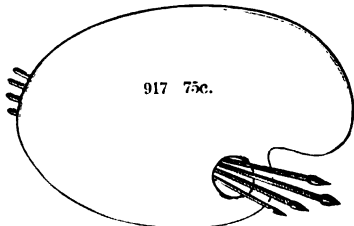

937 \$1.00.



665 60c.

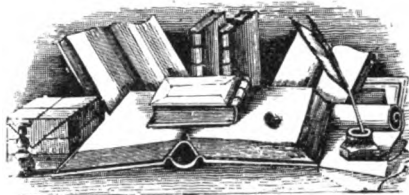

668 10c.



669 30c.



801 \$1.00.

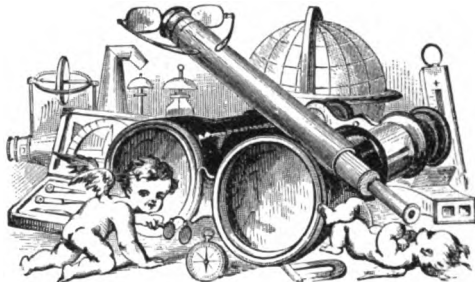

673 60c.

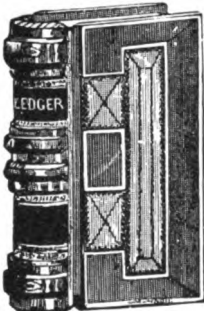

670 40c.



157 5c.



1233 \$1.00.



1228 75c.



1294 60c.

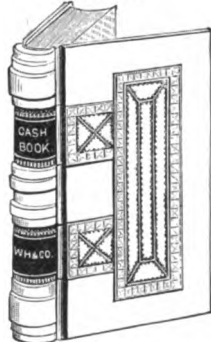

812 \$1.25.



985 \$1.00.



1823 75c.

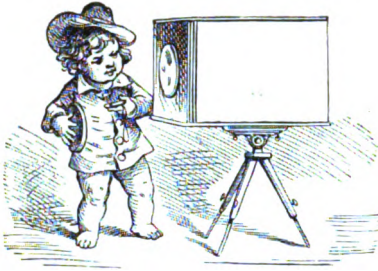

813 \$1.00.

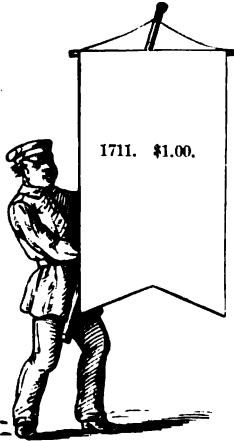

1711. \$1.00.



1488 \$1.25

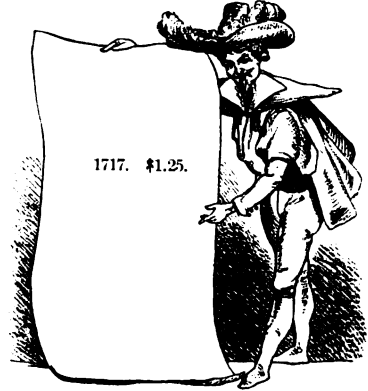

1717. \$1.25.

711 90c.



472 25c.



672 10c.



1231 75c.

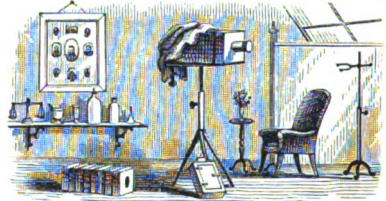

1238 \$1.25.

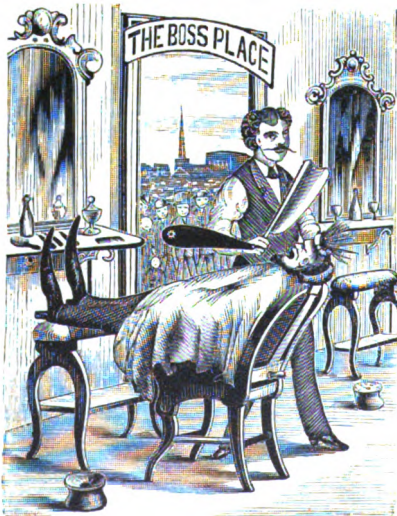

1116 \$1.00.

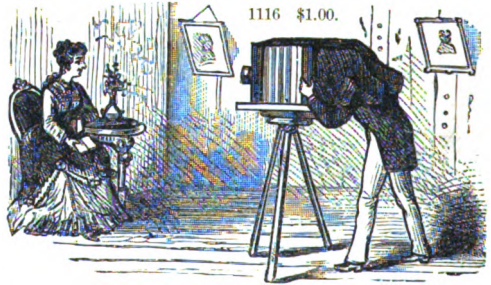

1120 \$1.00.

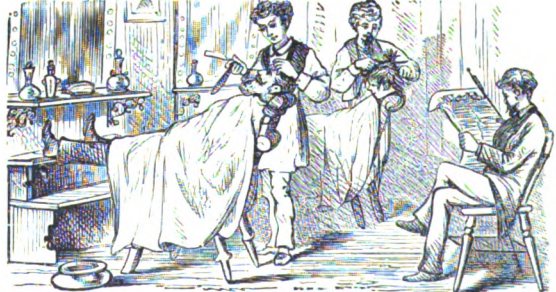

922 \$1.25.

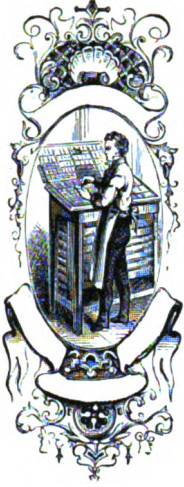

1348 50c.

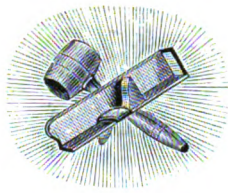

692 50c.



1071 50c.



006 75c.



1224 75c.

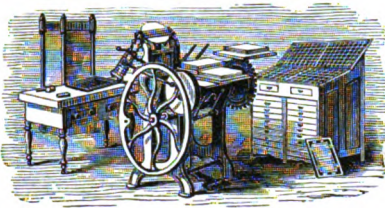

2130 35c.



1201 75c.

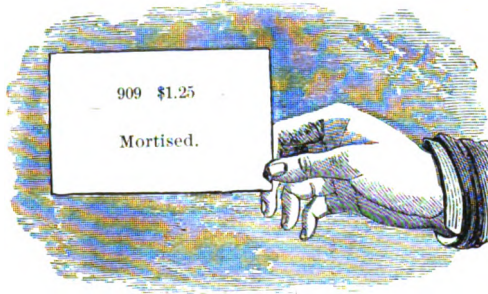
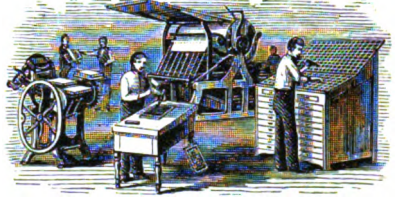

811 \$1.00.

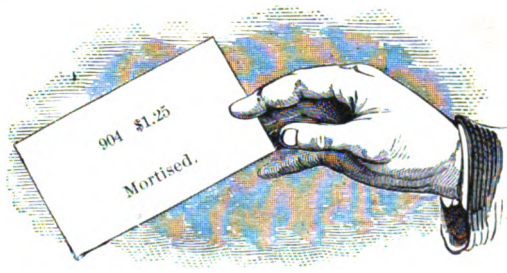
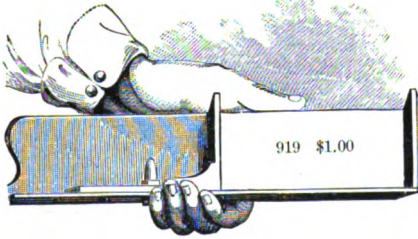
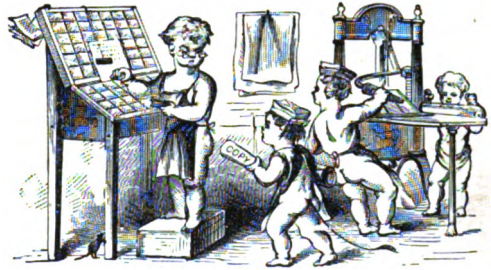

590 \$1.00.



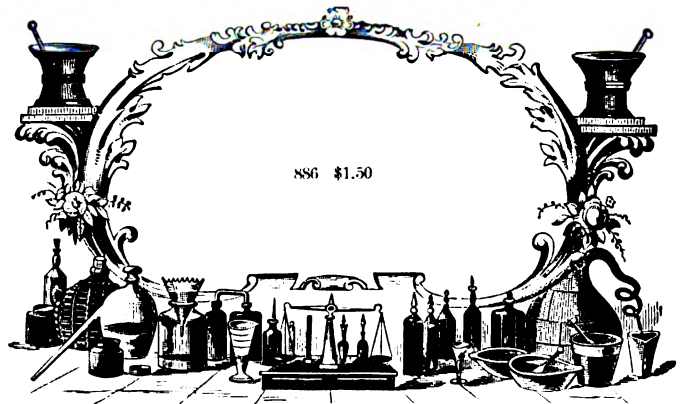
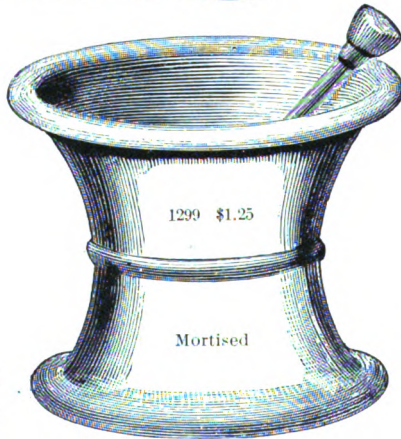
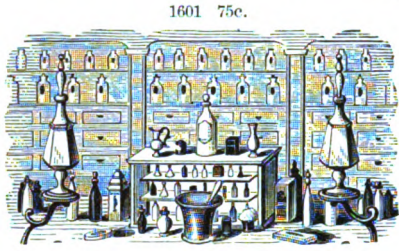
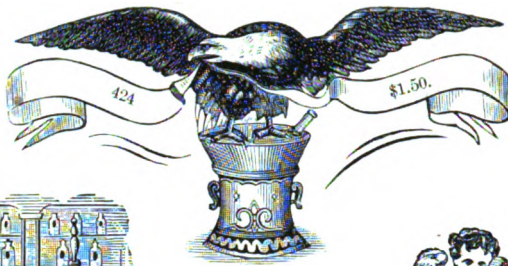



1301 \$1.00



1304 50c.



646 75c.



645 75c.



821 \$1.00

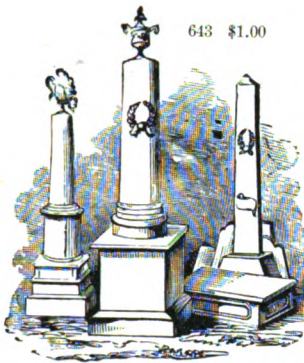

643 \$1.00

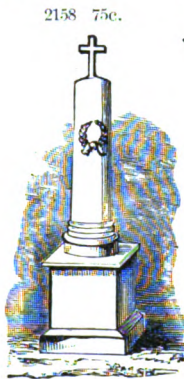

2158 75c.

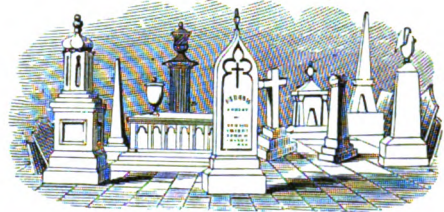

642 90c.



1303 \$1.00



1766 25c.



644 25c.



1306 \$1.25.

Mortised.



1302 50c.

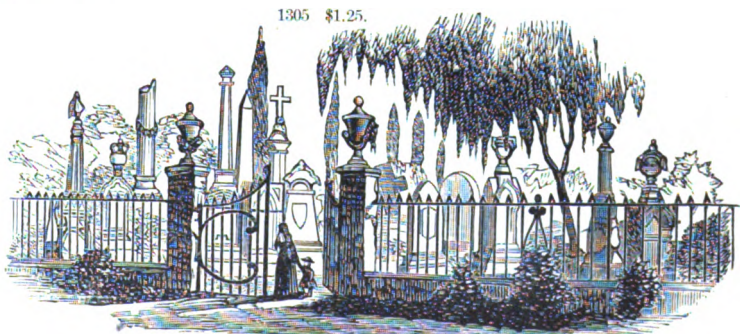

1305 \$1.25.

1350 60c.



602 75c.

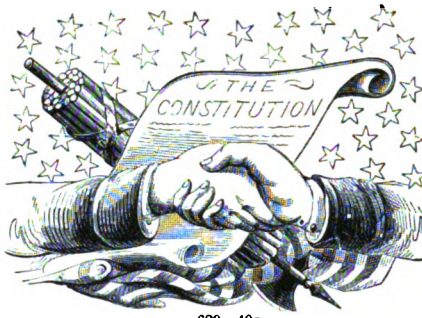

1820 60c.



594 \$1.00.

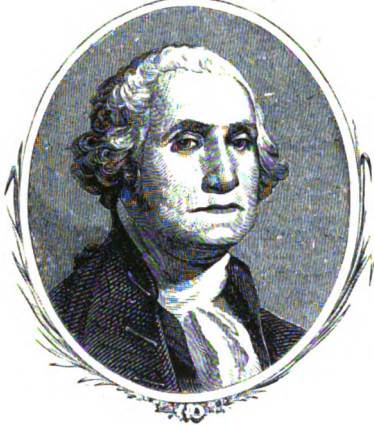

620 40c.



1351 \$1.00.



593 40c.



601 \$1.25.



595 40c.



1347 50c.



1819 50c.



596 \$1.00.



1346 40c.



592 \$1.00.



1356 40c.



50

Cincinnati Type Foundry, 201 Vine St.

523 50c.



525 60c.

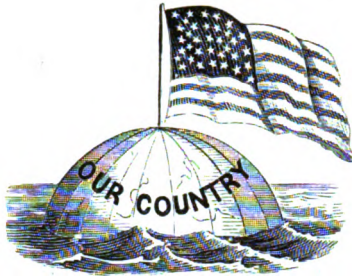

522 50c.



2173 40c.



1491 40c.



526 \$1.00



527 30c.



443 75c.

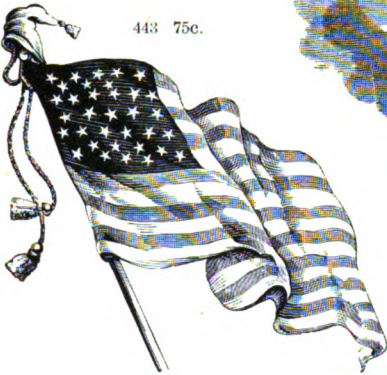

444 75c.

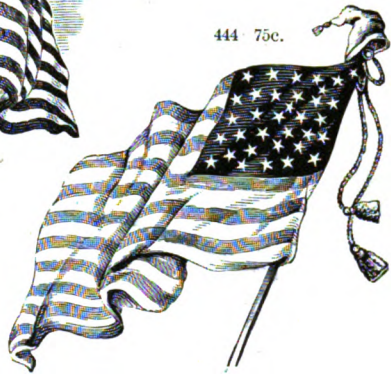

249 30c.



528 25c.



931 30c.



926 30c.



442 \$1.00

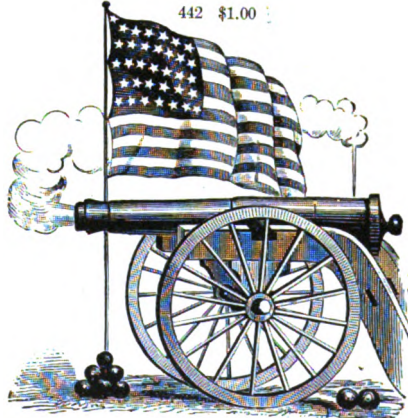

445 \$1.25

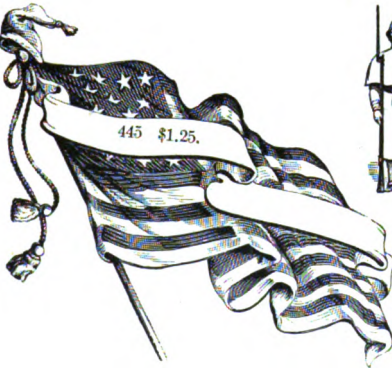

928 25c.



1137 \$1.00



1134 \$1.00.

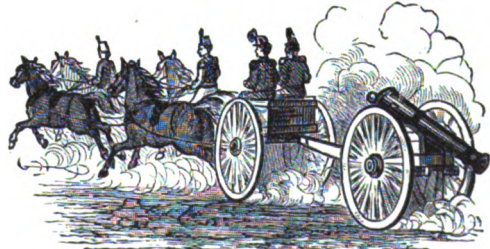

250 25c.



1634 75c.



422 30c.



437 50c.



257 30c.



294 40c.



421 \$1.25.



428 20c.



438 50c.



435 75c.



1357 20c.



1505 20c.



439 \$1.00.



433 75c.



1361 60c.



436 60c.



1358 \$1.50



Mortised

434 50c.



1046 \$1.00.



1514 50c.



427 60c.



426 50c.



1363 \$1.25.

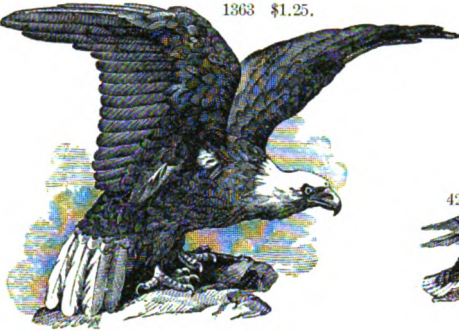

425 20c.



440 75c.



423 10c.



126 15c.



1359 \$1.50

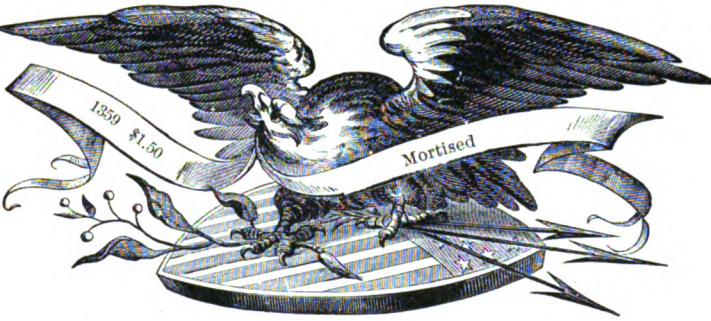

1360 50c.



159 5c.



420 \$1.00.



431 \$1.00.

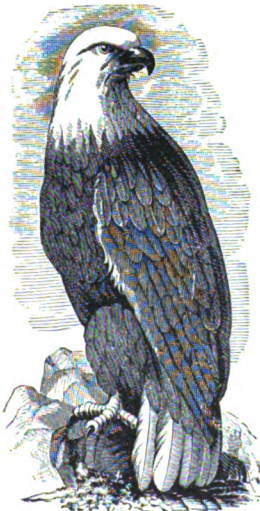

1362 \$1.25.

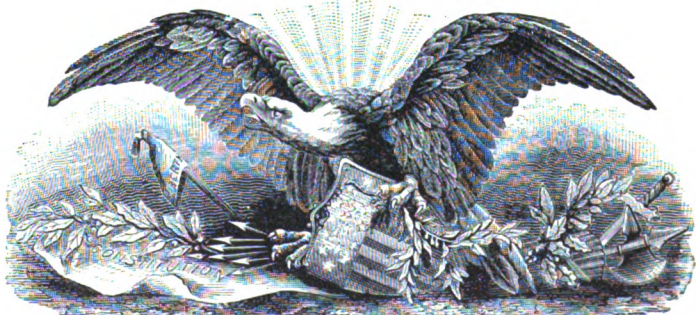

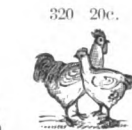
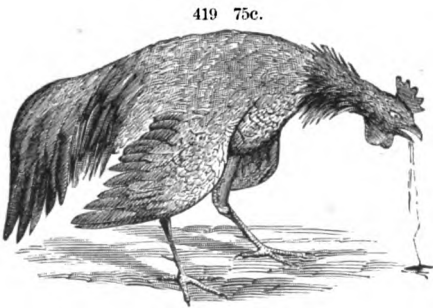
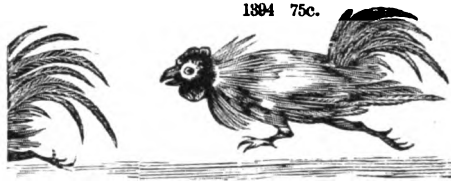

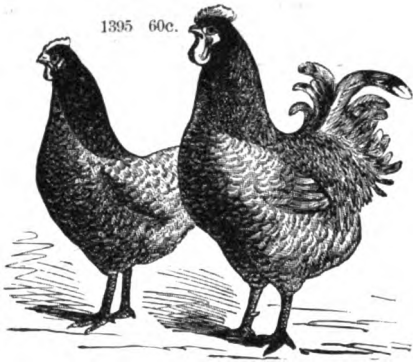

1395 60c.



576 30c.



715 20c.

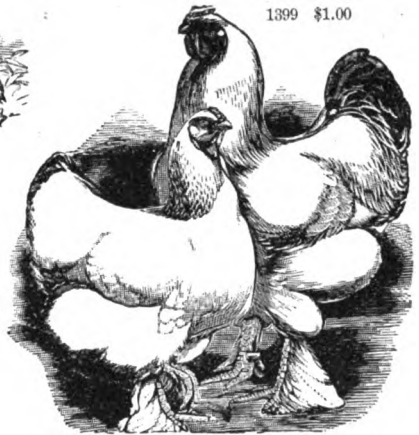

1399 \$1.00



2196 40c.



2197 50c.

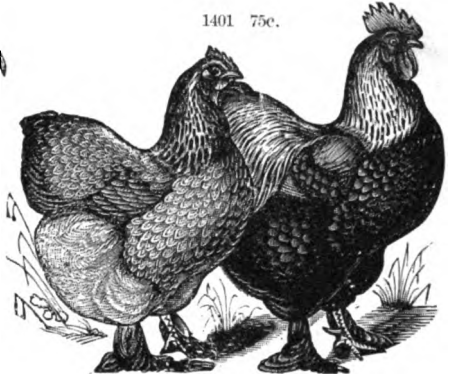

1401 75c.

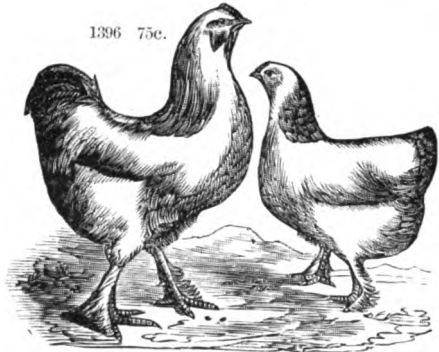

1396 75c.

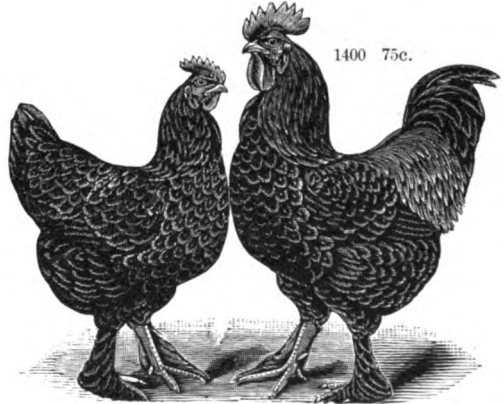

1400 75c.

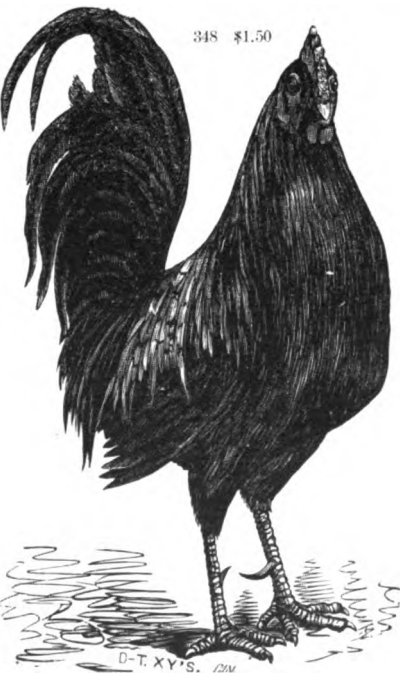

348 \$1.50



1837 \$1.25

D-T. XY'S. 13M

1469 25c.



346 30c.



1743 25c.



1793 25c.



342 35c.



1578 75c.

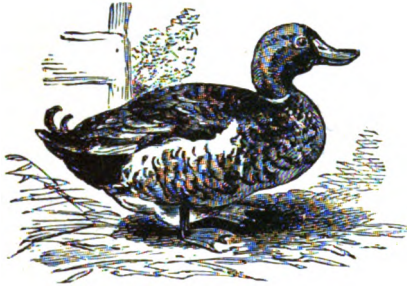

1468 35c.

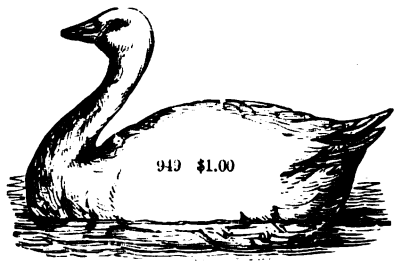

949 \$1.00

1882 \$1.50.

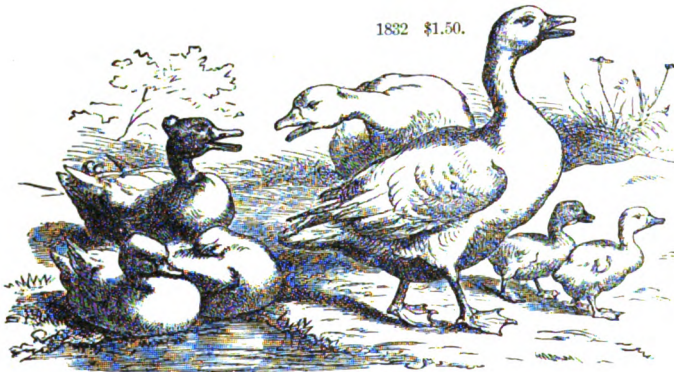

351 50c.



1577 75c.

1798 25c.



1402 \$1.50.



1579 50c.

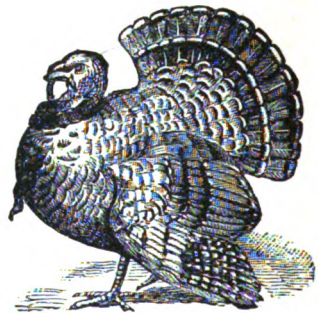

1580 \$1.00.

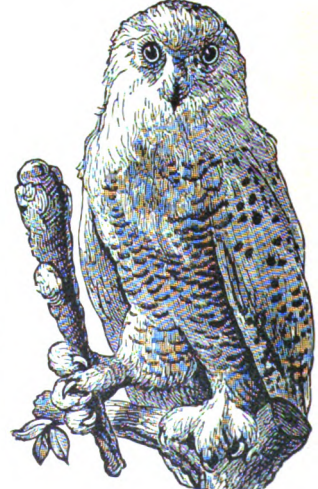

1651 25c.



1070 50c.



1435 60c.

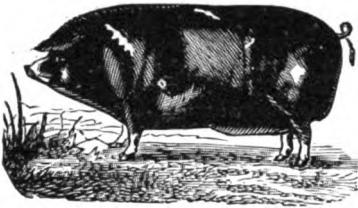

1470 60c.

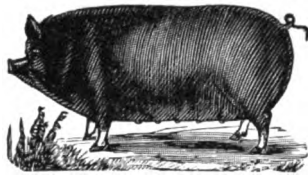

330 50c.

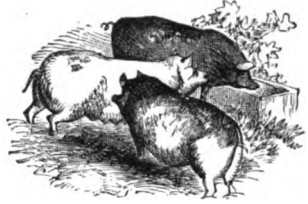

1055 75c.

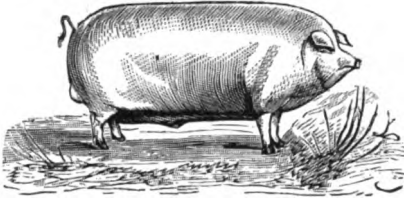

1431 25c.



1471 75c.



737 20c.



1434 75c.

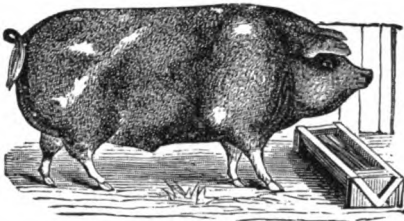

1430 20c.



1076 75c.

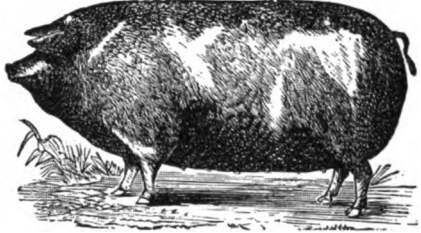

1750 25c.



1835 \$1.50.

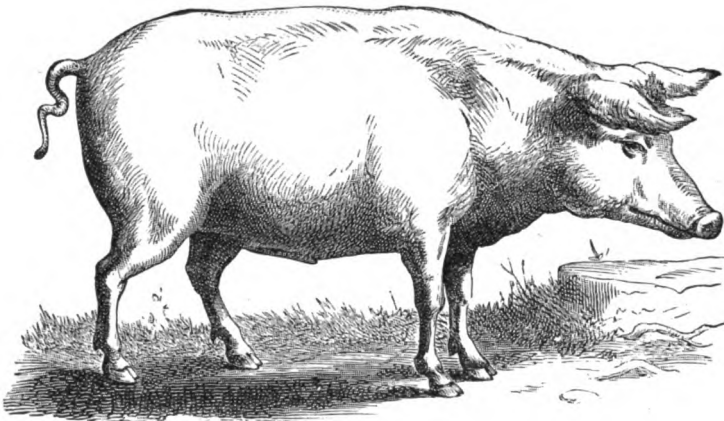

1438 40c.



1053 40c.



1440 \$1.50.

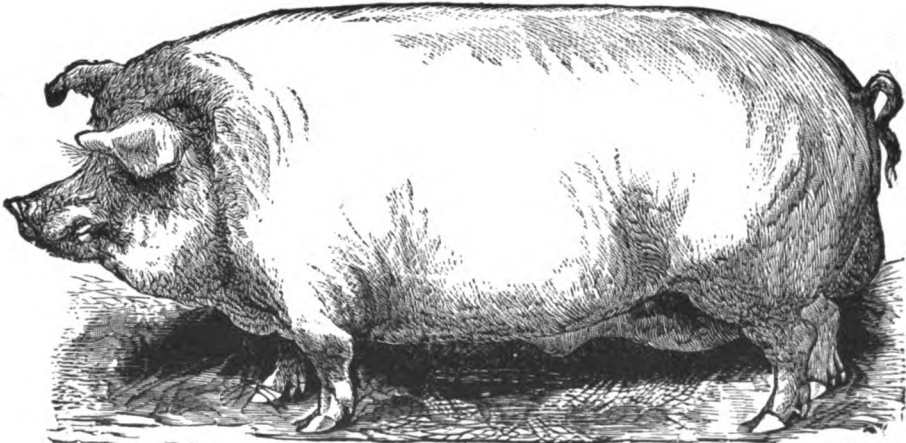

1602 35c.



1603 35c.



1604 35c.



1605 35c.



1606 35c.



1607 35c.



1608 35c.

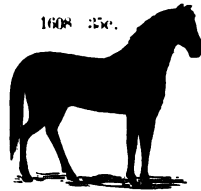

1609 35c.



1610 35c.



1611 35c.



1612 35c.



1613 35c.



Cuts Nos. 1602 to 1613, with brands cut to order. 50 cents each.

1388 \$1.00.



1467 75c.

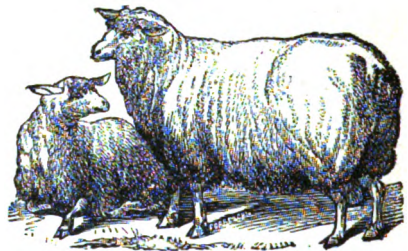

1466 50c.

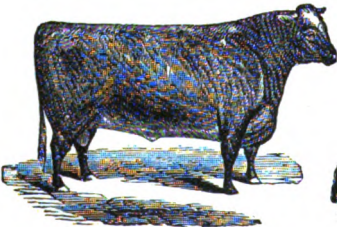

1746 20c.



1617 75c.



716 20c.



1392 40c.



1894 \$1.25.

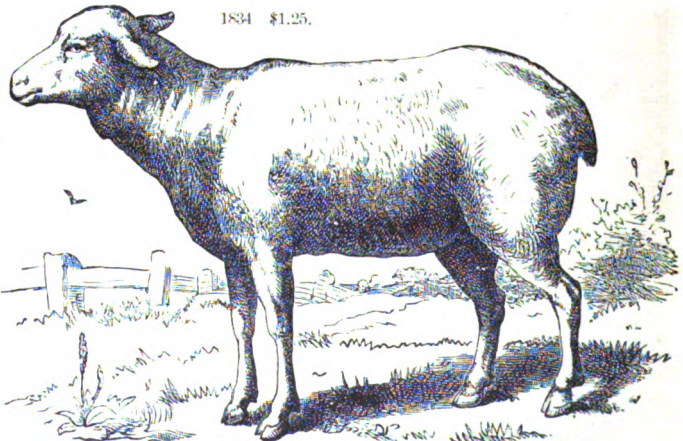

334 50c.



1436 75c.

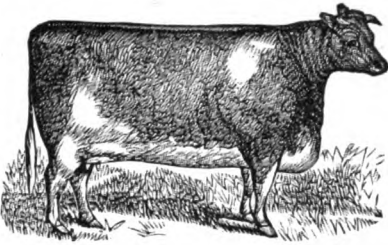

321 10c.



1437 75c.

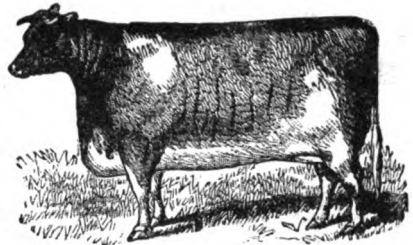

1795 25c.



323 30c.



336 \$1.25.

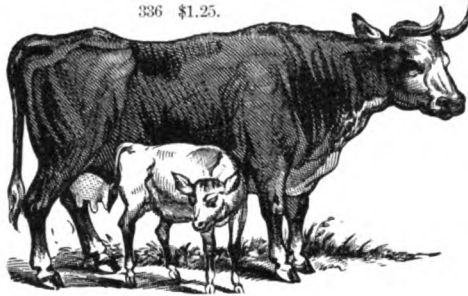

324 30c.



1810 30c.



349 40c.



1747 20c.



333 \$1.50.



718 20c.



757 20c.



1748 20c.



1773 30c.



1073 75c.



1389 75c.



322 30c.



1833 \$1.25.



1391 \$1.00



735 20c.



314 15c.



317 25c.



272 10c.



1752 20c.



345 60c.



338 60c.



574 60c.



335 75c.



1573 60c.

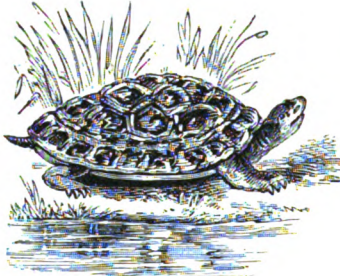

1627 75c.



1565 35c.



1321 \$1.25.

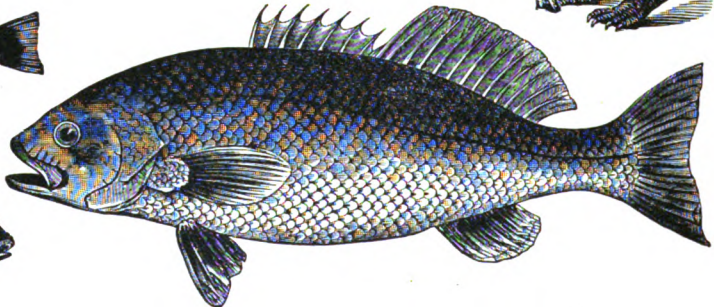

1566 50c.



1567 90c.

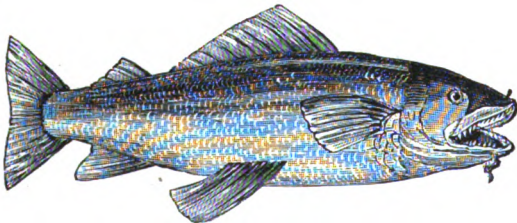

1568 40c.



341 60c.



1051 \$1.25.

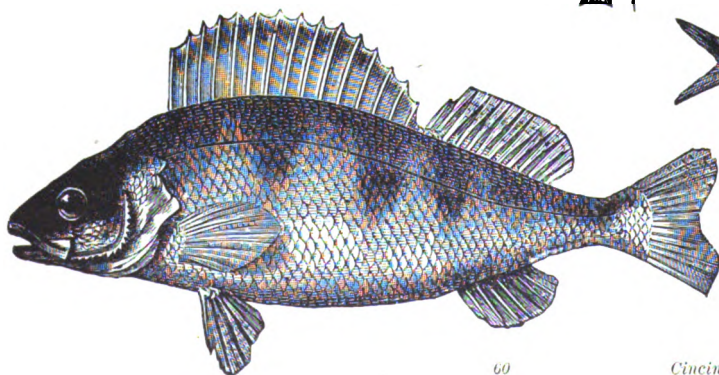

1564 35c.



1039 40c.



327 60c.



280 10c.



1390 50c.



281 10c.



1386 50c.



288 10c.



289 10c.



1572 60c.



1574 75c.



1569 60c.



951 75c.



292 10c.



1826 \$1.00.



1576 75c.



332 60c.



1387 75c.



1571 50c.

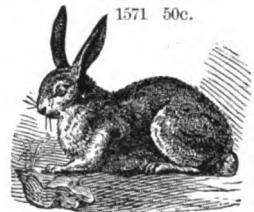

1573 50c.



337 60c.



1570 75c.



1038 50c.



1385 60c.



301 75c.

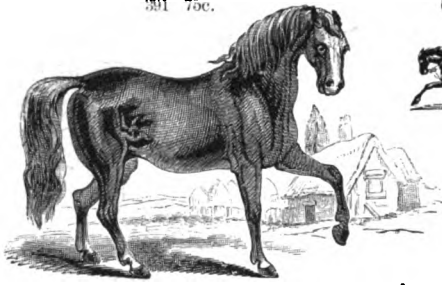

651 15c.



392 75c.



386 15c.



379 75c.



1799 25c.



1775 25c.



1802 25c.



1058 \$1.00.

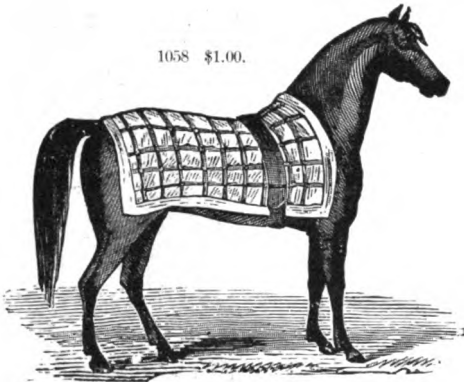

1380 75c.

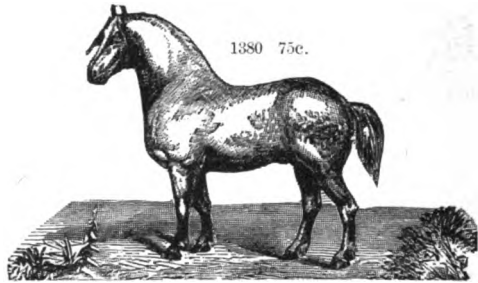

1749 25c.



717 25c.



1381 75c.

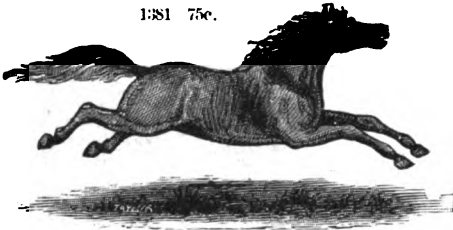

388 15c.



1840 \$3.50.

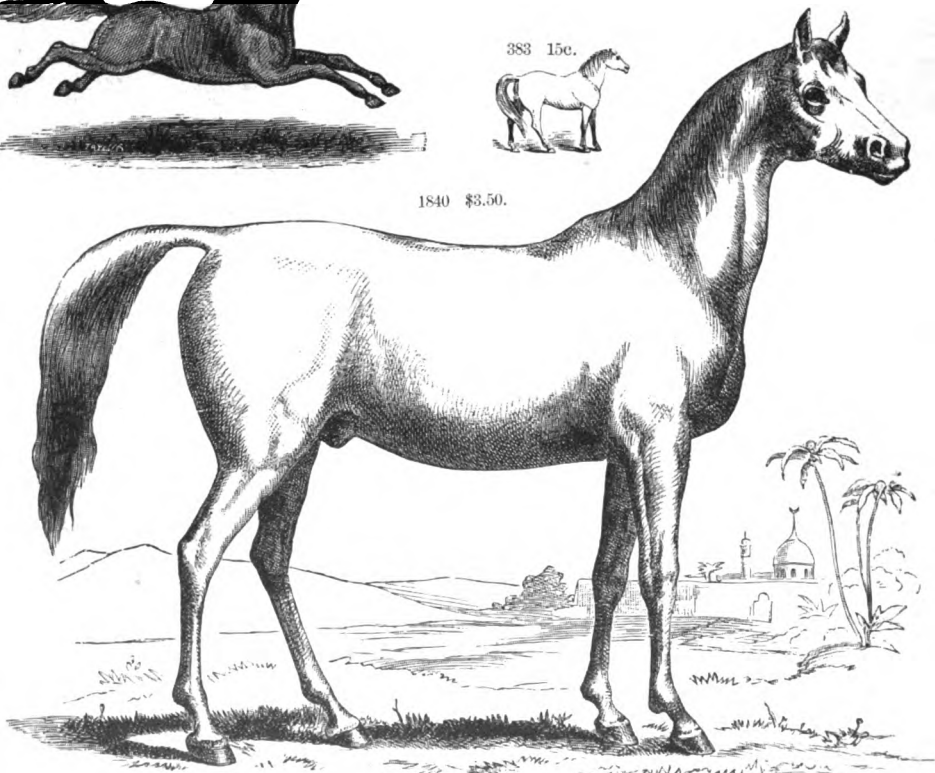

382 50c.

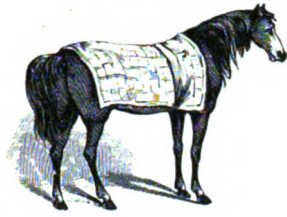

1379 60c.

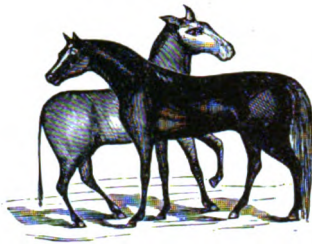

387 60c.



1061 75c.

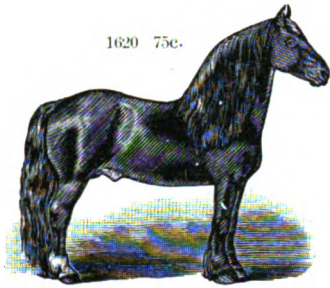

1620 75c.



1057 75c.

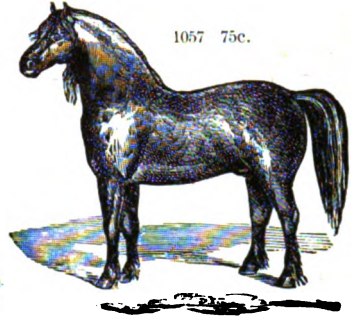

414 75c.

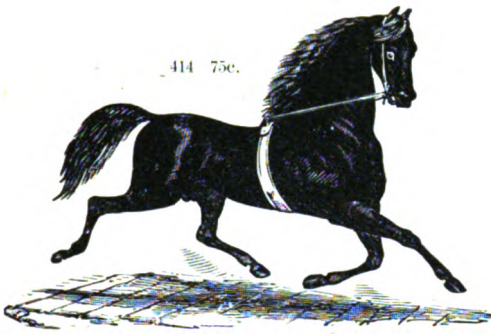

1618 75c.

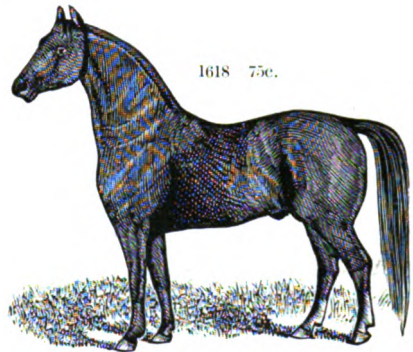

1841 \$3.50.

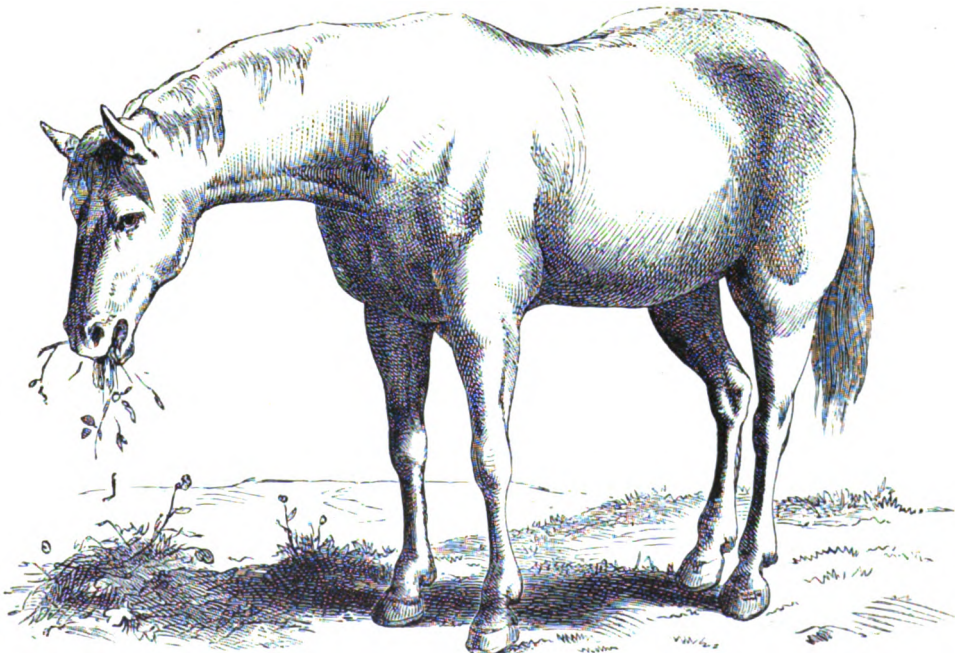

Sheets of large Stock Cuts sent on application.

Cincinnati Type Foundry, 201 Vine St.

389 40c.



1614 75c.



390 40c.



328 50c.



308 20c.



307 15c.



1794 25c.



1797 25c.

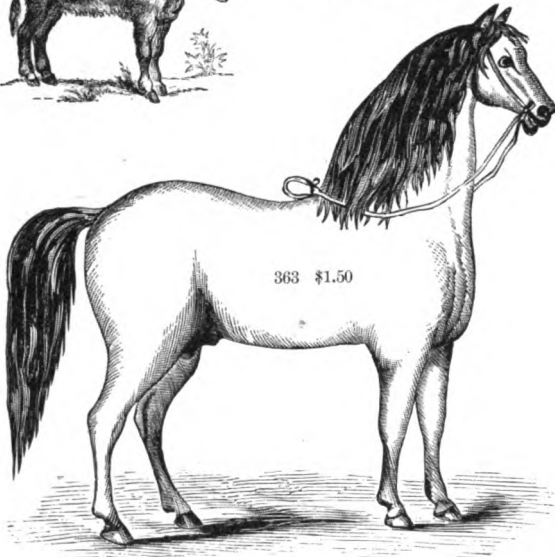

363 \$1.50

312 15c.



1815 40c.



326 15c.



381 75c.

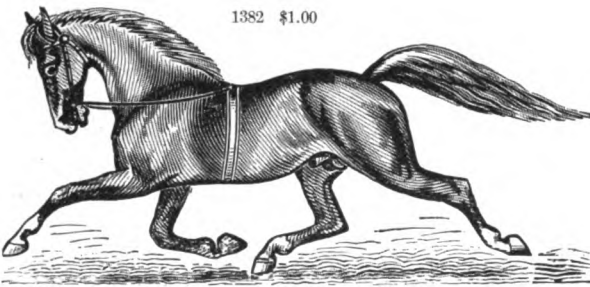
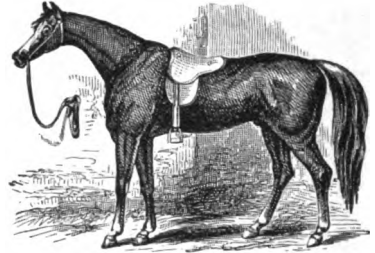

1382 \$1.00

1616 50c.

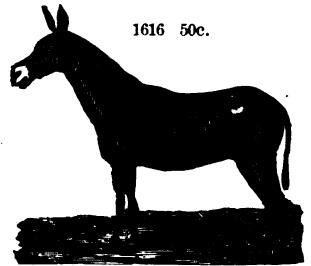

1751 20c.



728 20c.



1383 \$1.25.

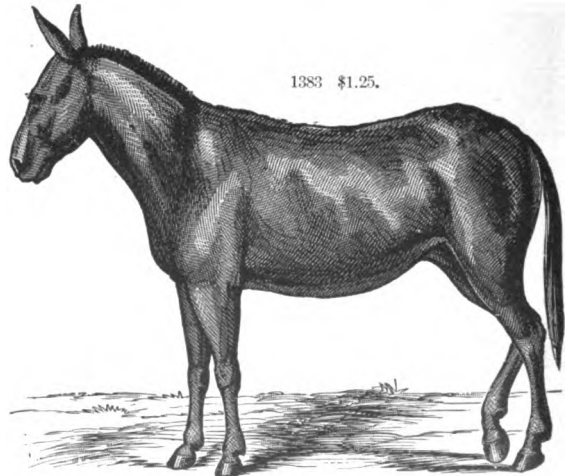

1492 75c.

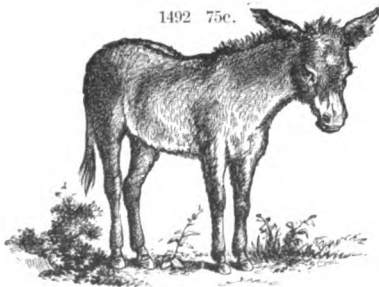

Sheets of large Stock Cuts sent on application.

Cincinnati Type Foundry, 201 Vine St.

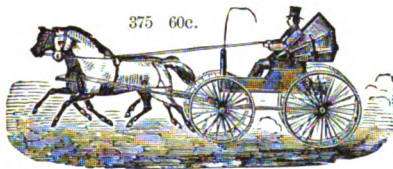
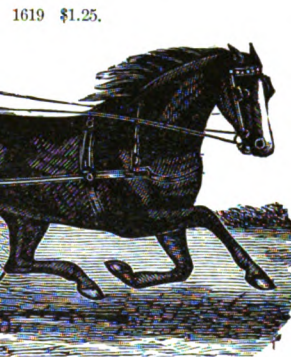
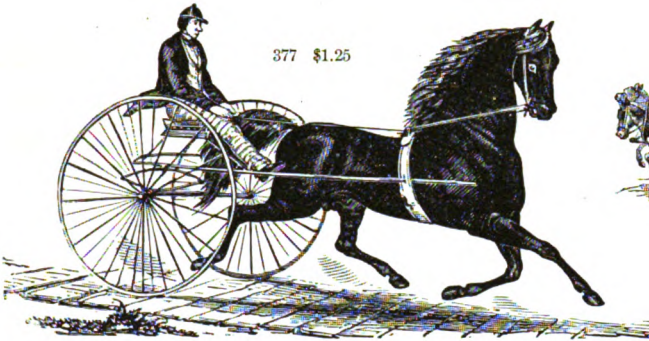
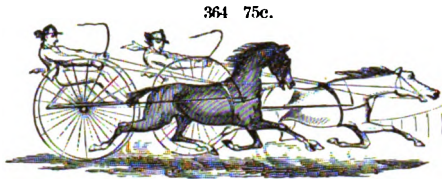
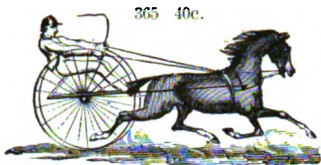

388 \$1.00.

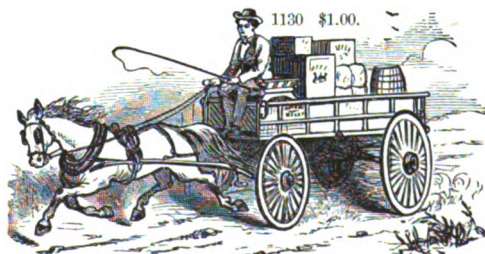
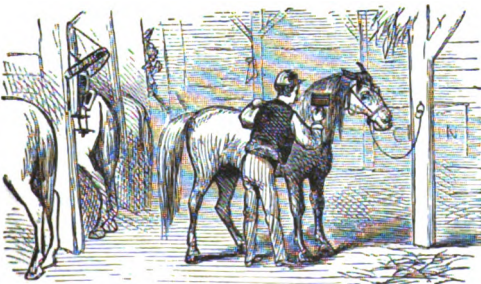
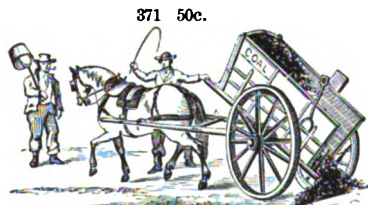

367 50c.



267 15c.



369 75c.



228 15c.



1818 75c.

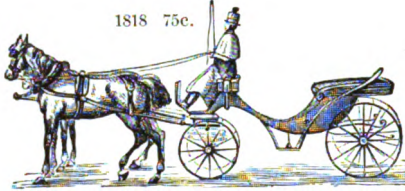

1816 75c.



251 25c.



366 50c.

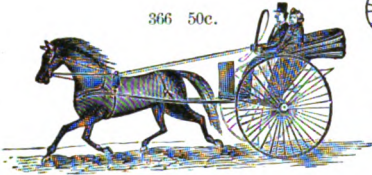

376 75c.



374 25c.



368 75c.

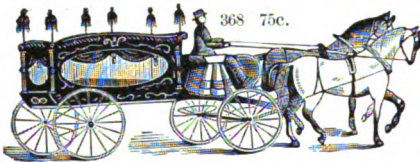

1369 75c.



1377 50c.



1809 25c.



372 75c.

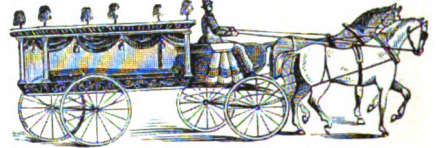

1131 \$1.00.

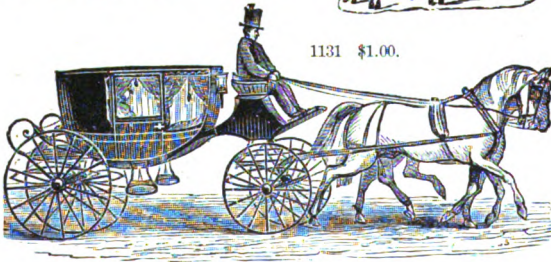

2136 \$1.00.



373 50c.

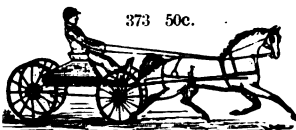

1800 25c.



1136 \$1.00.

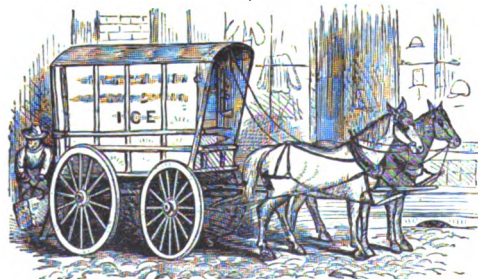

1129 \$1.00.

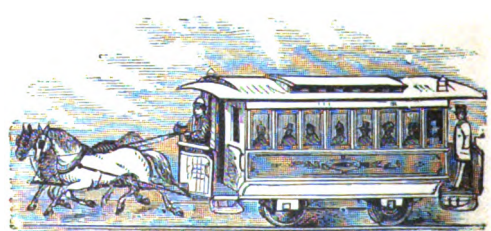

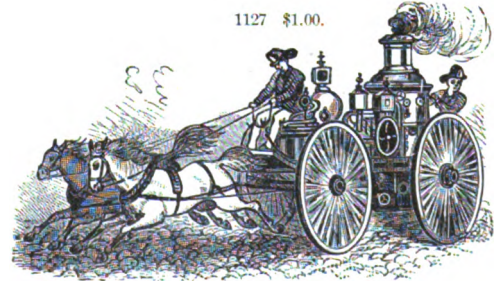
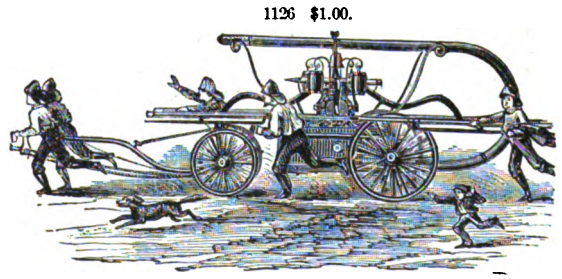
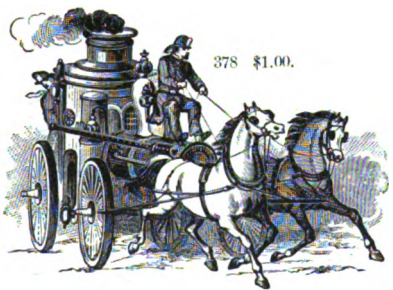
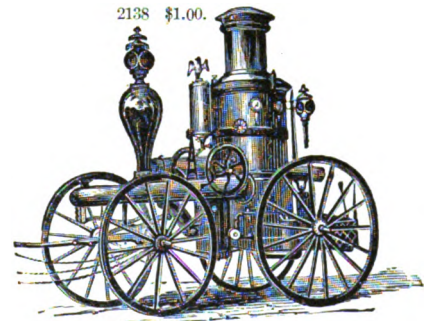
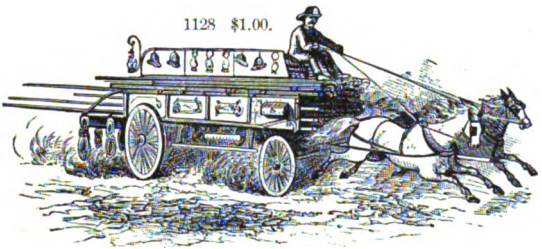
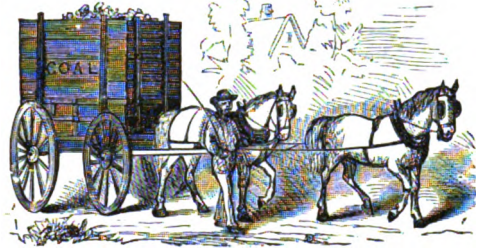
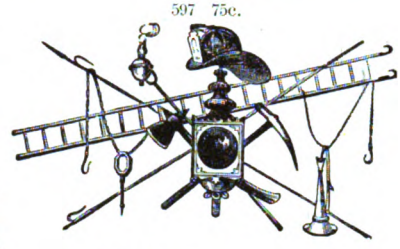
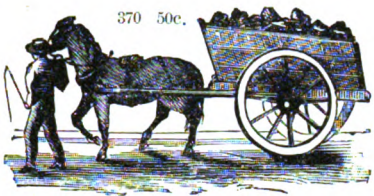
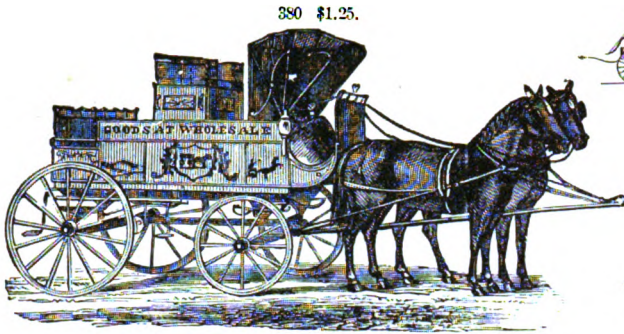

1368 50c.

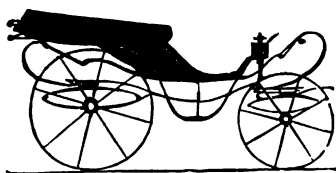

939 30c.



853 65c.

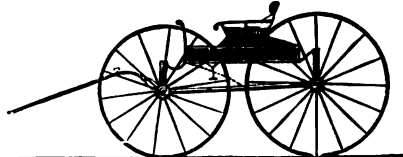

1374 75c.

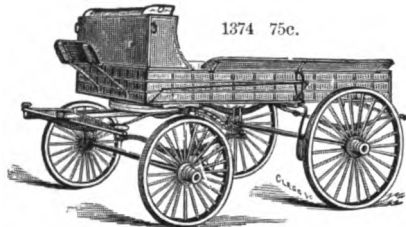

1808 25c.



1218 75c.



1373 75c.

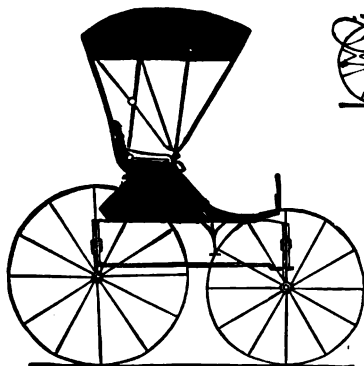

848 30c.

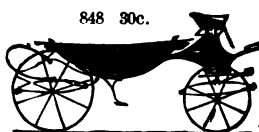

235 10c.



179 10c.



859 50c.

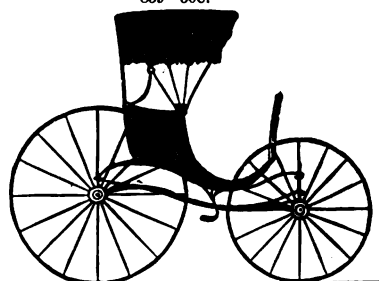

856 15c.



189 5c.



2223 50c.

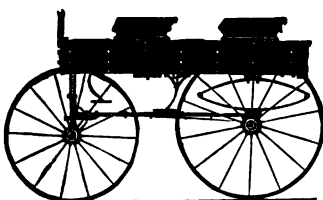

2224 50c.

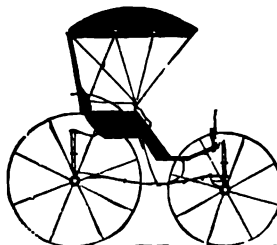

2225 75c.



1067 75c.

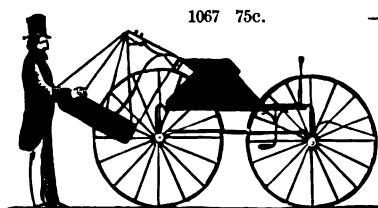

1754 25c.



2226 60c.



1371 \$1.25.

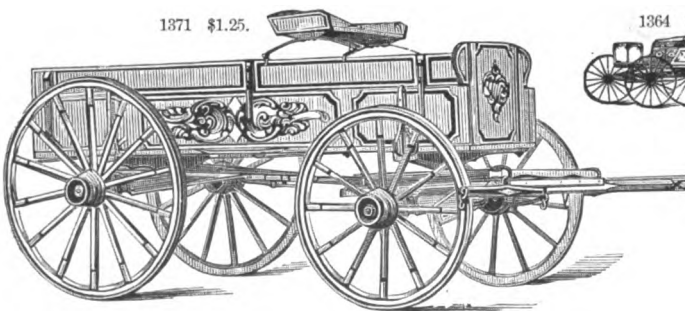

1364 30c.



847 30c.



1366 40c.





185 5c.



175 5c.

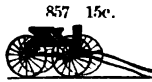

857 15c.



180 5c.



236 10c.

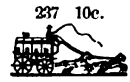

237 10c.



846 50c.

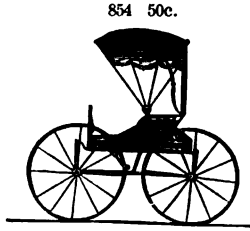

854 50c.

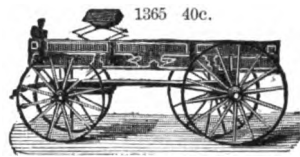

1365 40c.

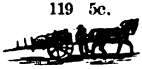

119 5c.

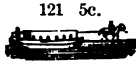

121 5c.



13 5c.

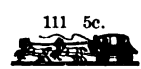

111 5c.

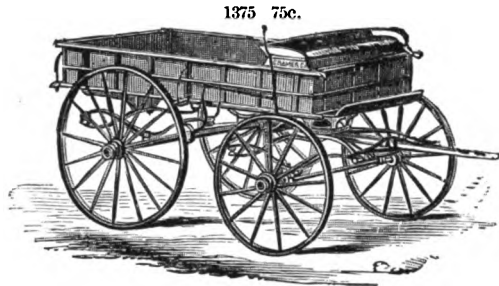

1375 75c.

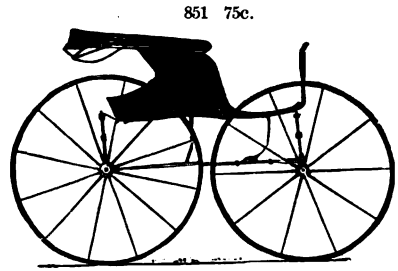

851 75c.



681 40c.

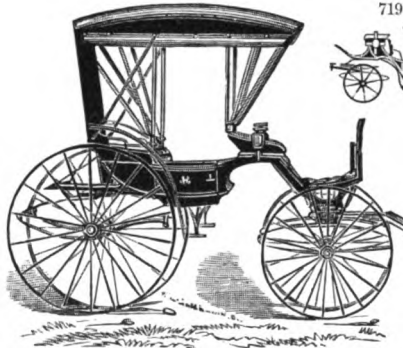

1376 75c.



719 20c.

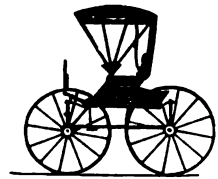

850 30c.

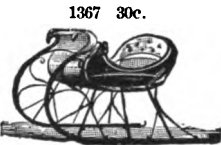

1367 30c.



849 30c.



1132 \$1.00.

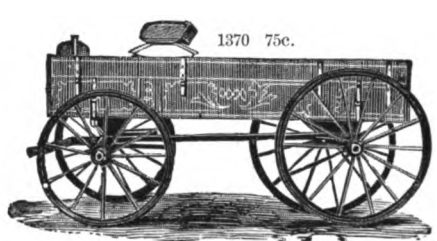

1370 75c.



1372 50c.



1056 \$2.00.

When the price accompanies the order, cuts are sent prepaid by express or mail.

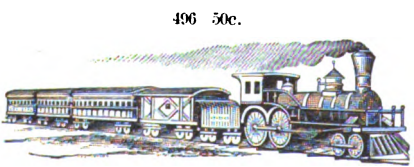
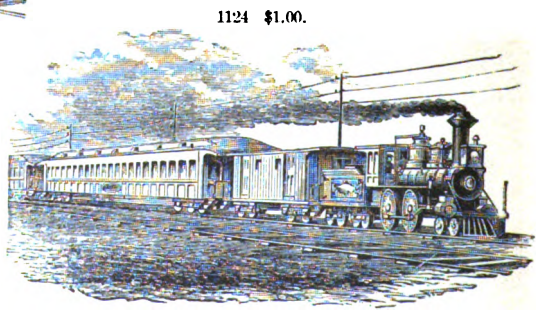
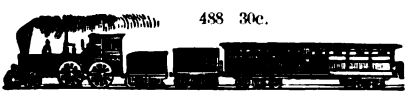
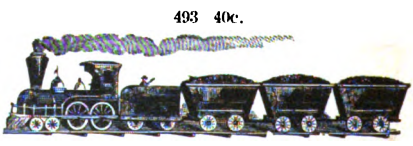
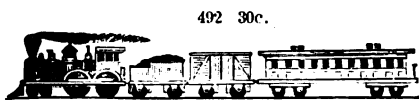
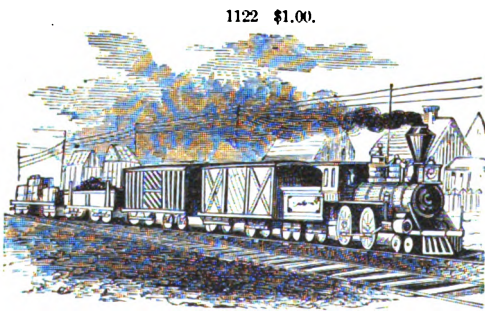
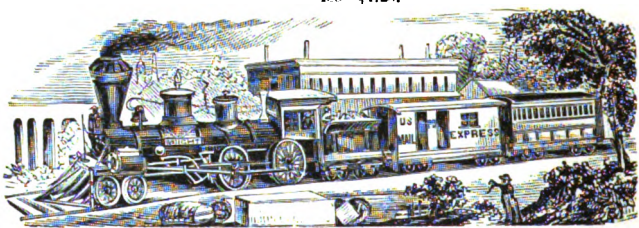
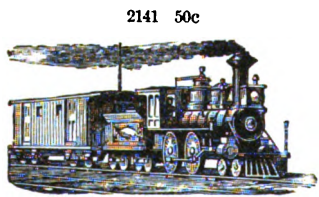
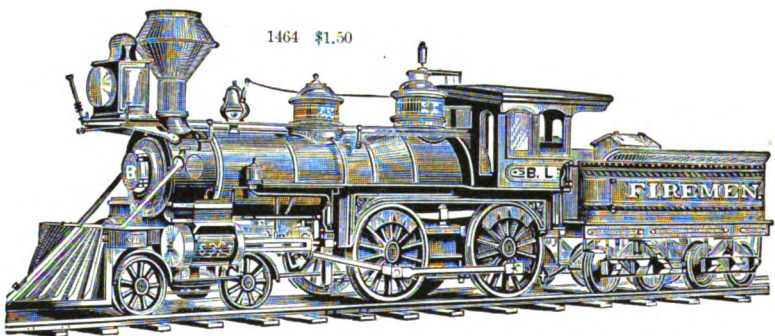
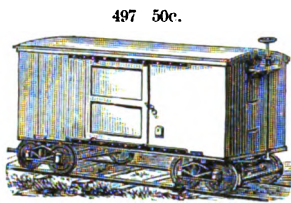
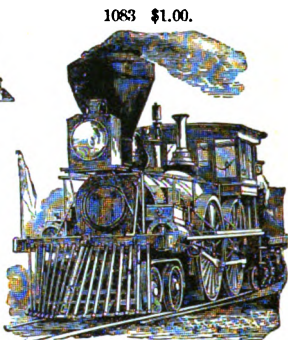
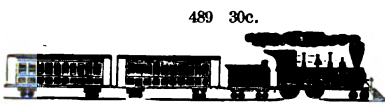
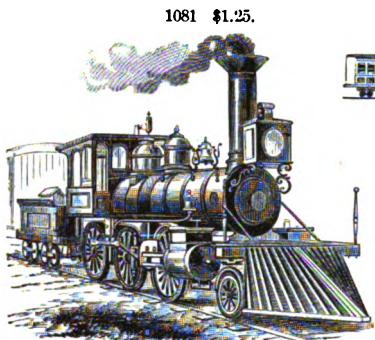
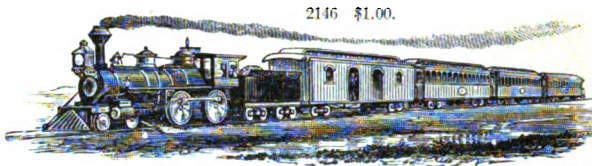
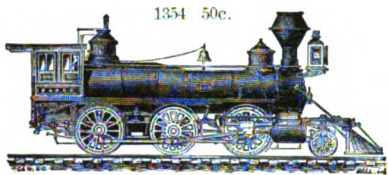

1465 \$1.00.



498 50c.

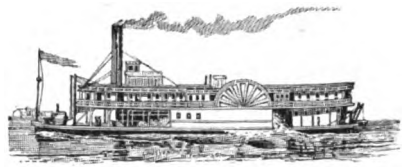

510 75c.

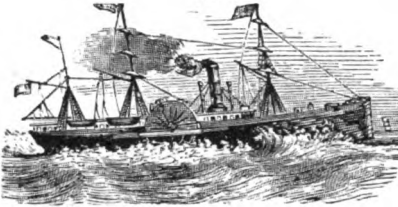

514 \$1.00.

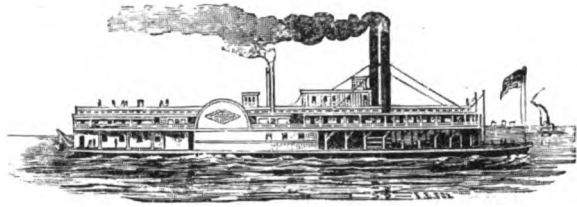

503 \$1.00.

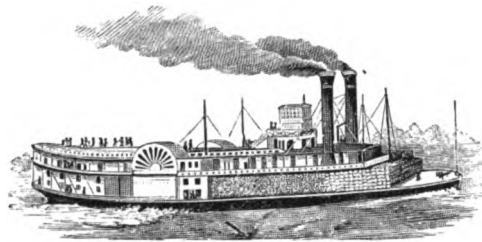

509 \$1.00.

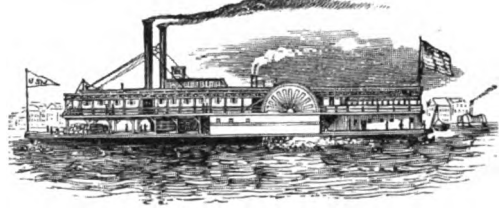

502 50c.

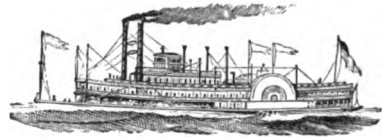

501 \$1.25.

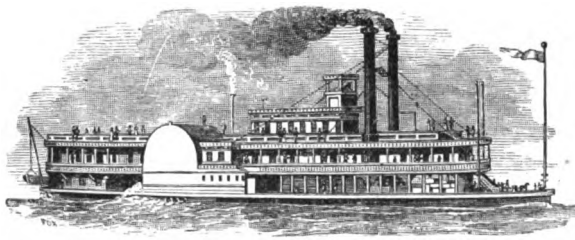

511 \$1.25.

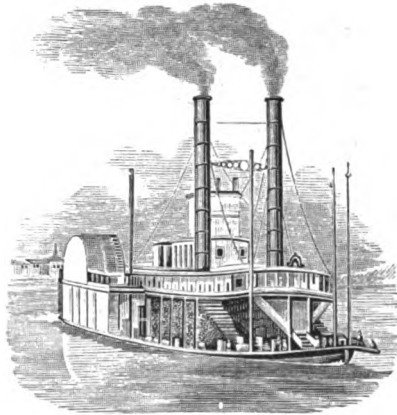

499 \$1.00.

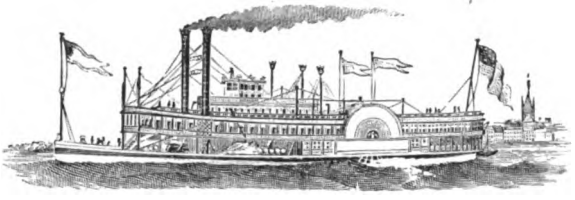

500 35c.

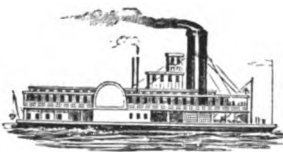

515 \$1.50.

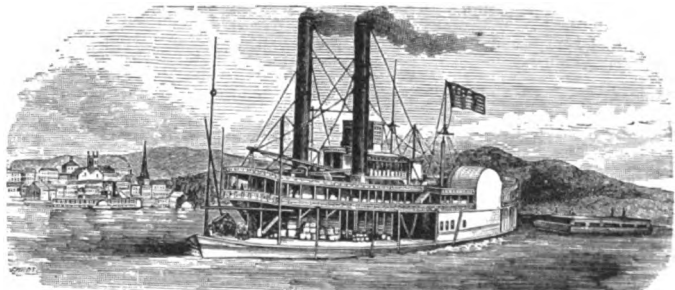

1494 35c.



When the price accompanies the order, cuts will be sent prepaid by express or mail.

1865 25c.



1770 25c.



1778 25c.



1791 25c.



1772 25c.



225 15c.



1591 25c.



219 10c.



1813 25c.



1589 25c.



1322 20c.



1590 20c.



1586 30c.



110 5c.



1587 50c.

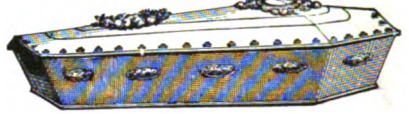

1588 75c.

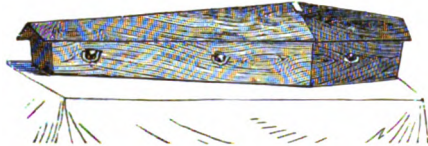

687 15c.



1592 50c.

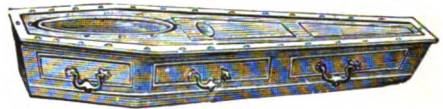

2200 \$2.00.

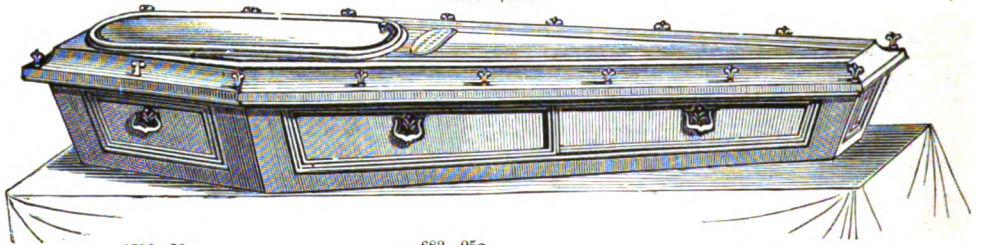

1596 50c.

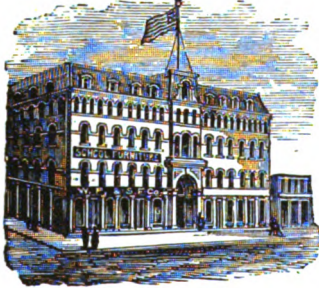

683 25c.



1632 \$1.00.

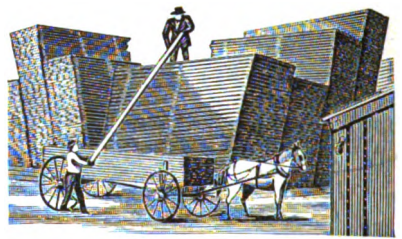

2199 40c.



1063 75c.

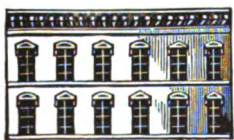

2198 75c.



2140 40c.

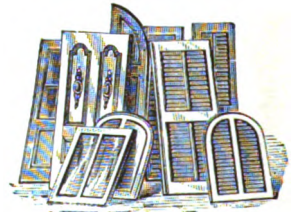

Two Pieces.



1594 \$1.00.

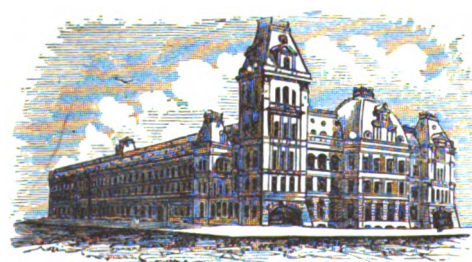

1150 \$1.00.



1615 50c.



1515 50c.



1622 90c.

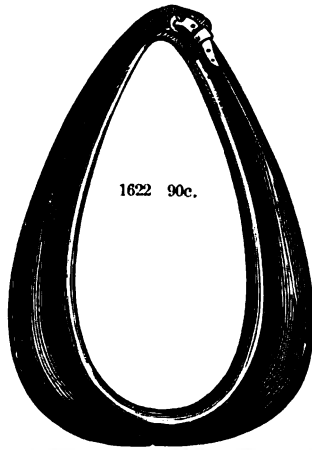

282 15c.



278 15c.

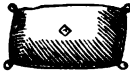

301 15c.



171 15c.



1629 75c.

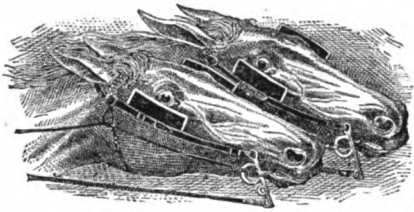

1593 \$1.00.

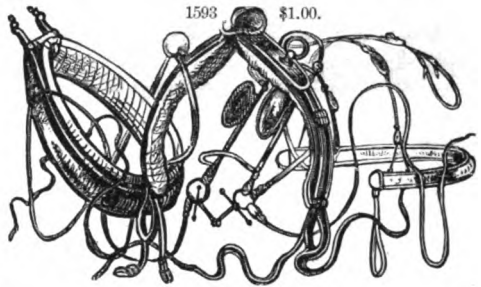

1623 50c.



1621 \$1.25



1585 \$1.25.



1625 40c.



647 15c.

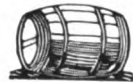

1282 75c.

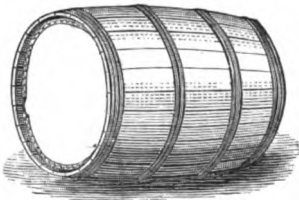

2139 75c.

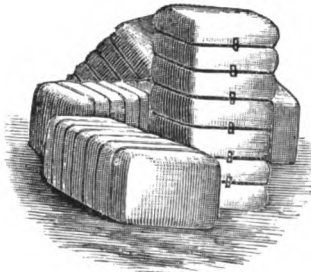

1283 75c.



1633 75c.

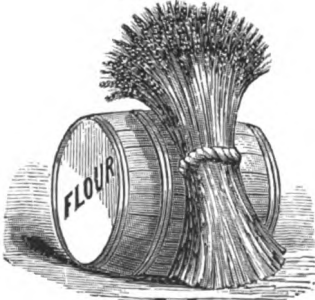

2143 30c.



2201 \$1.25.



1804 25c.



1758 25c.



1771 25c.



1806 25c.



1760 25c.



1742½ 25c.



1583 75c.

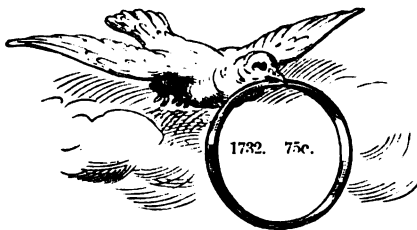
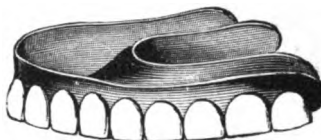

1744 25c.



1824 75c.



1582 30c.



1792 25c.



1581 30c.

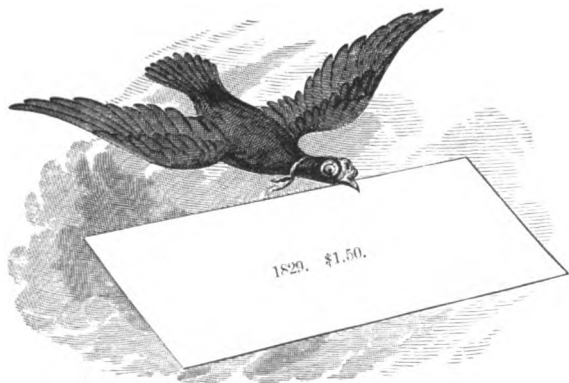
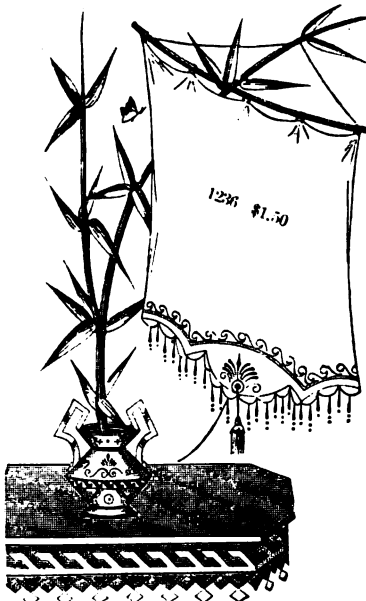

750 15c.



790 30c.



1415 50c.



751 30c.



2202 50c.



740 20c.



260 5c.



792 15c.



741 20c.



1403

60c.

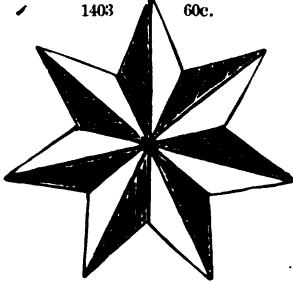

1410

50c.

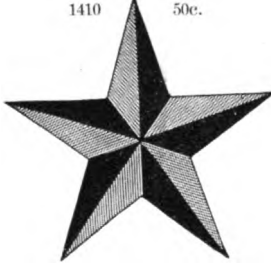

1486

60c.



524 \$2.50.



1332 75c.



538 \$1.50.



531 75c.



685 10c.



212 10c.



536 \$1.00.



554 10c.



1330 \$1.00.



Seals furnished for any State like above specimens.

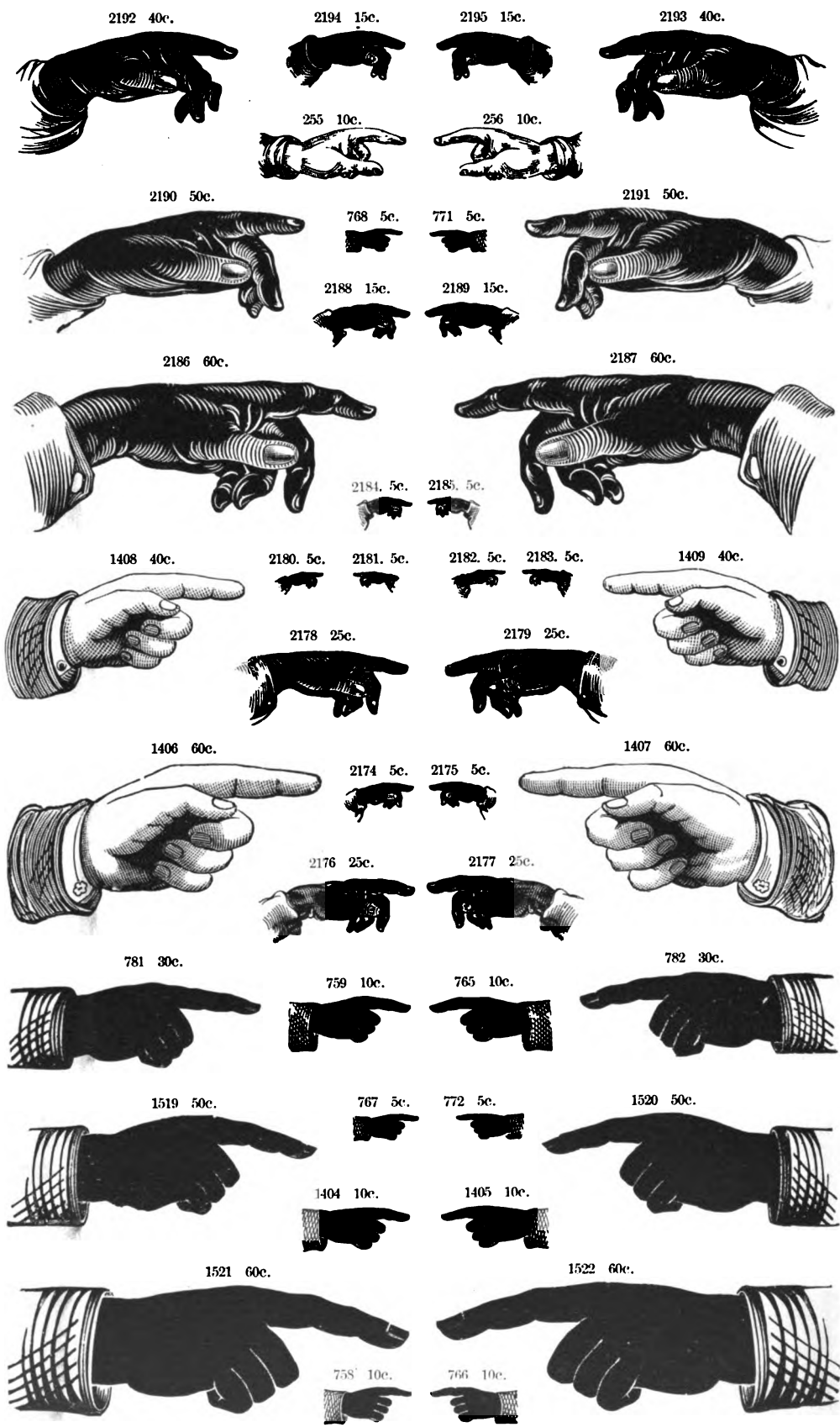

When the price accompanies the order, cuts are sent prepaid by express or mail.



HEAD AND TAIL PIECES.



1925 30c.



1926 30c.



1880 30c.



1889 30c.



1909 40c.



1923 50c.



1920 50c.



1927 75c.



1928 75c.



1934 50c.

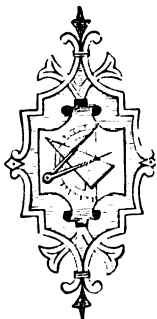

1930 60c.



1954 60c.



1967 60c.



1950 50c.



1968 75c.



1953 50c.



1924 25c.



1948 50c.



1960 75c.



1940 \$1.00.



1969 75c.



1966 75c.



1955 \$1.25.



1982 75c.



1975 75c.



1957 80c.



1971 75c.



2001 75c.



1983 75c.



1992 \$1.00.



1984 \$1.00.



2007 75c.

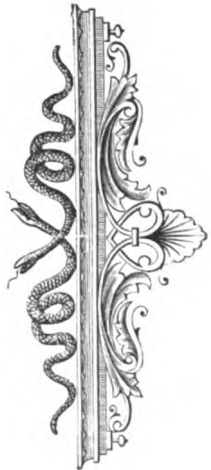

2030 \$1.25.



2022 \$1.00.



1947 30c.



1986 \$1.50.



1974 40c.



2008 \$1.00.



2019 \$1.00.



2016 \$1.00.



1970 75c.



1991 \$1.25.



2017 75c.

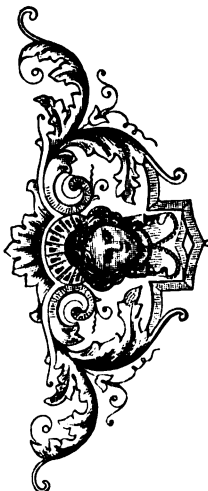

2002 \$1.50.

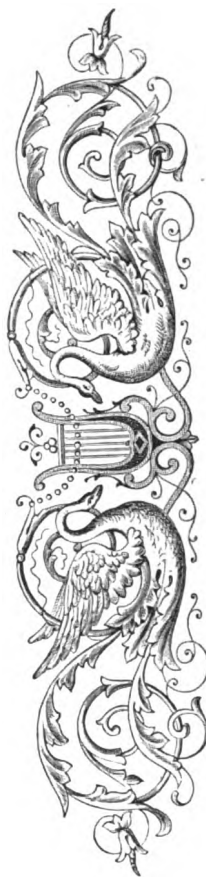

1989 \$1.50.



2057 \$1.00.



2055 \$1.00.

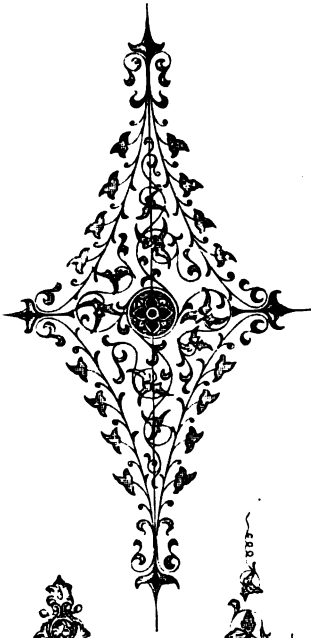

2063 \$1.00.

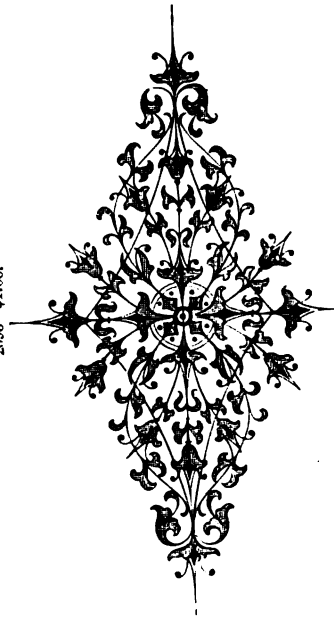

2025 \$1.00.

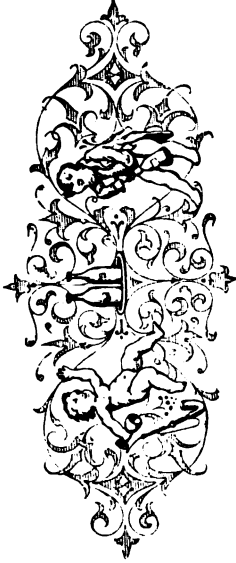

1944 40c.



2076 \$1.00.



2061 50c.

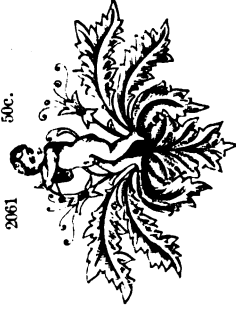

2068 \$1.00.

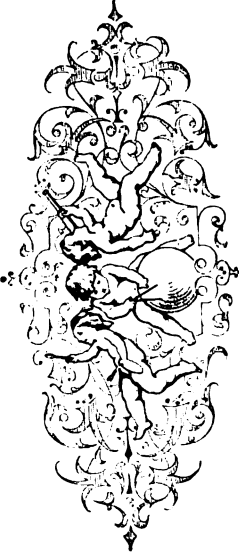

2070 \$1.00.

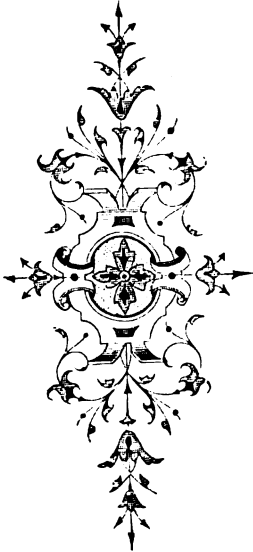

2102 \$1.25.

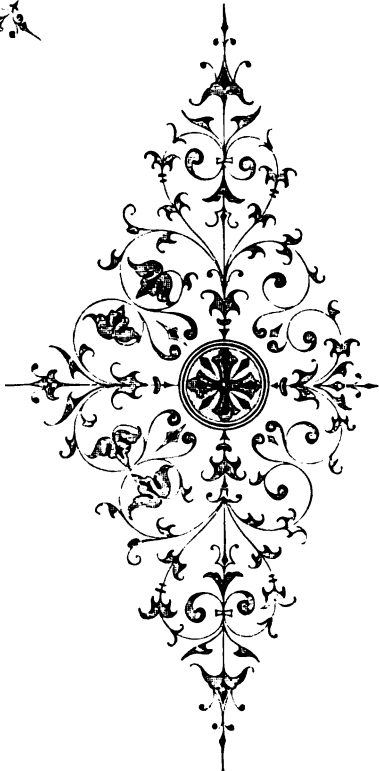

2056 75c.

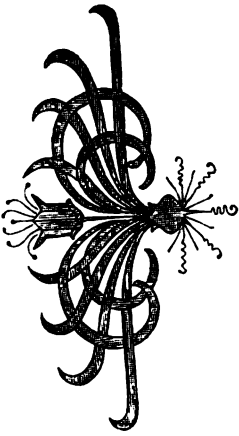

2001 75c.

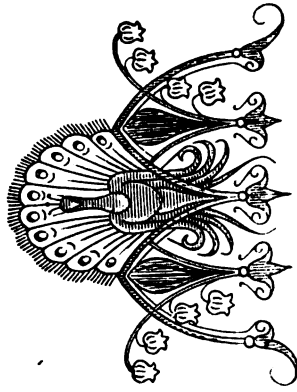

2006 75c.

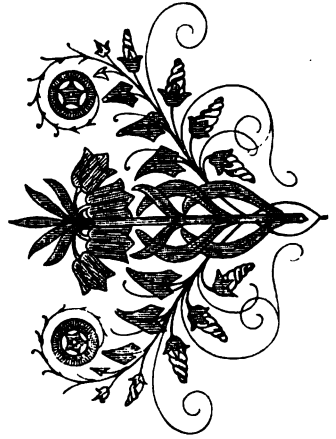

2073 60c.

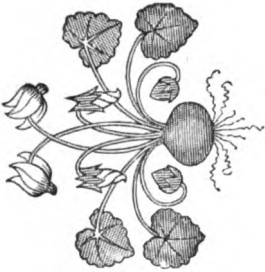

2000 60c.



2066 \$1.00.

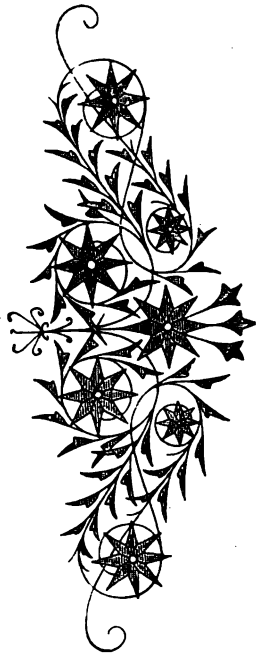

2074 75c.



2083 60c.

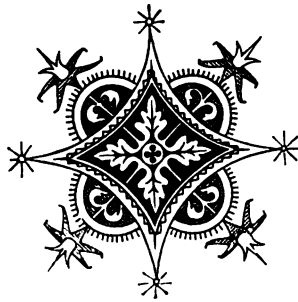

2079 75c.

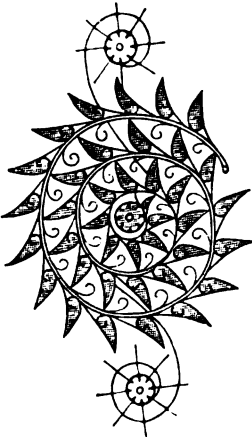

2006 75c.



2106 75c.

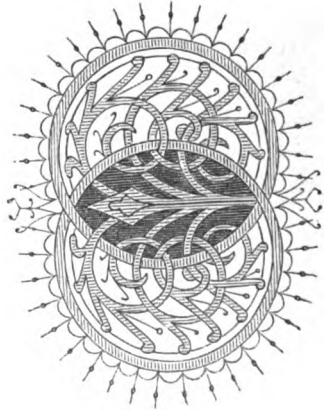

1951 75c.



2054 \$1.00.



1978 75c.

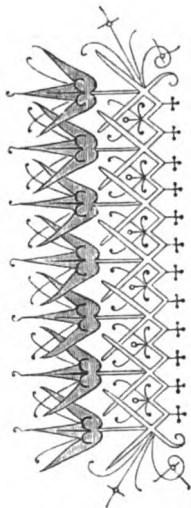

2092 75c.



2028 75c.



1987 60c.



1976 75c.



1980 50c.



1990 64c.



1977 75c.



2069 \$1.00.

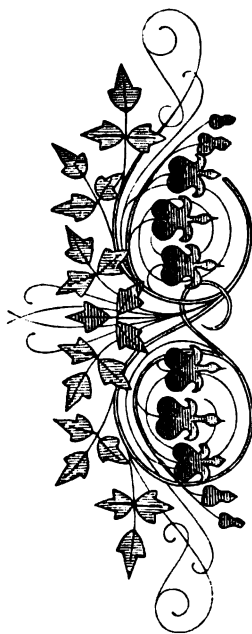

2062 75c.

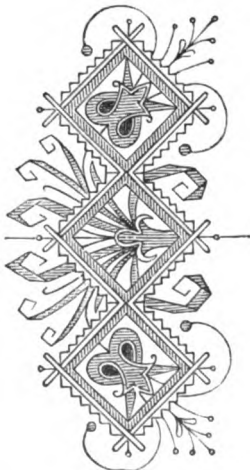

2015 \$1.00.

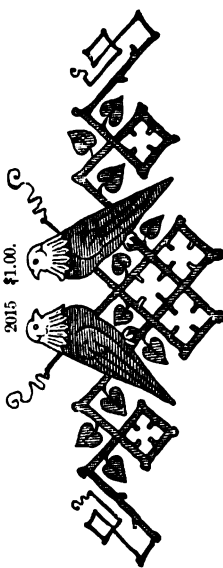

2075 75c.

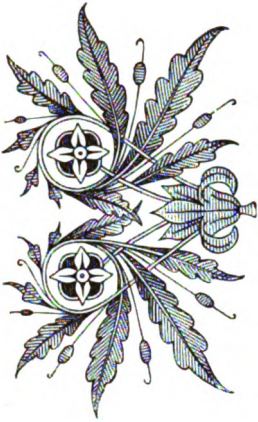

2068 75c.



2058 75c.

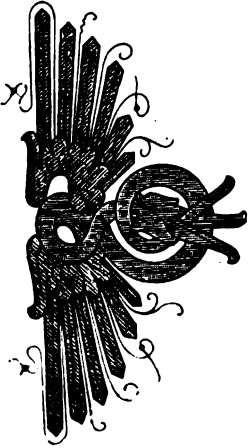

2077 75c.

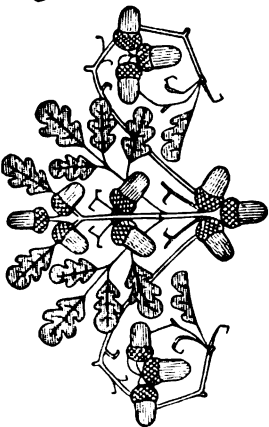

2085 \$1.25.

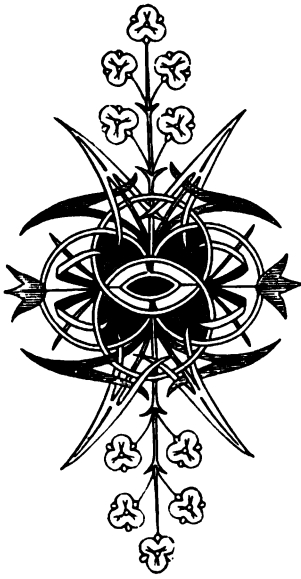

2000 \$1.25.

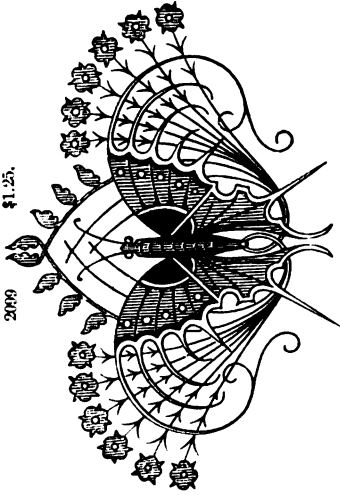

2080 \$1.25.

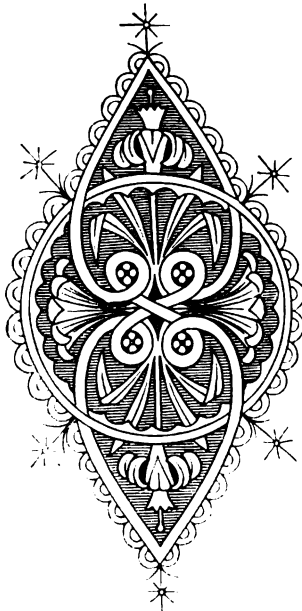

2084 \$1.00.



2004 \$1.25.

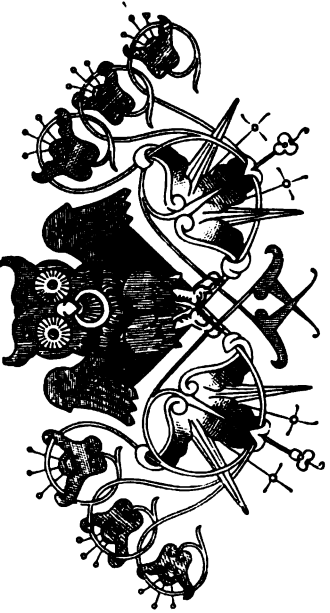

2080 \$1.00.

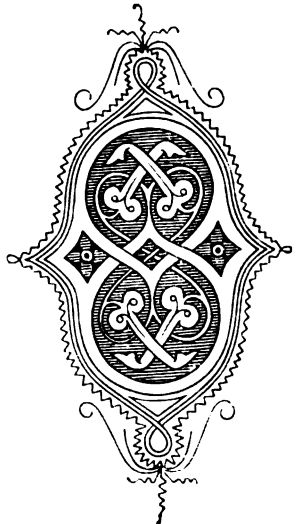

1985 \$1.00.

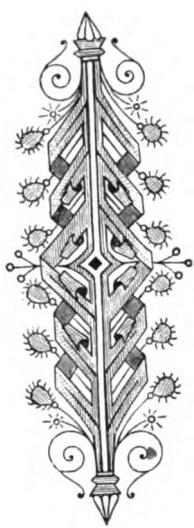

1988 \$1.00.

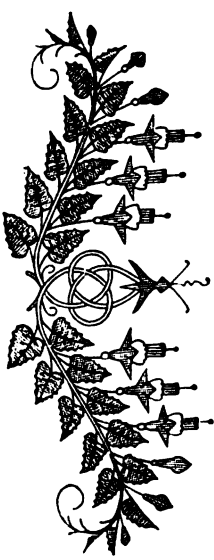

1972 75c.



2071 75c.



2083 \$1.25.

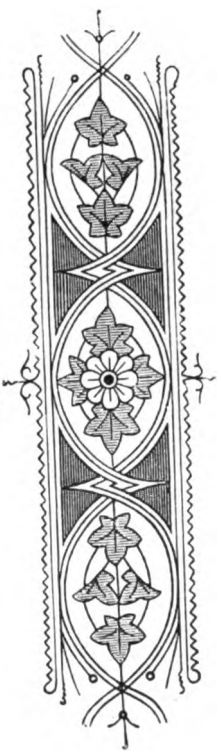

2013 75c.



1973 50c.

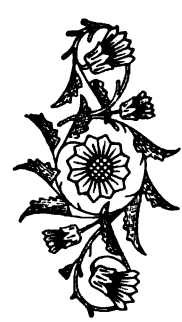

1994 \$1.50.



1979 60c.

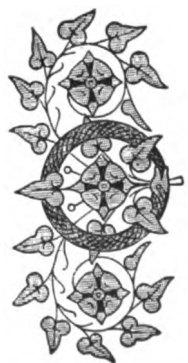



2064 60c.



2060 60c.



2014 60c.



2052 60c.

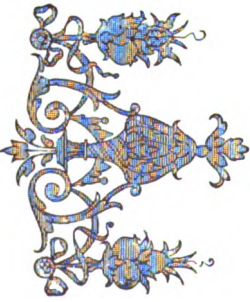

2072 60c.



2059 60c.

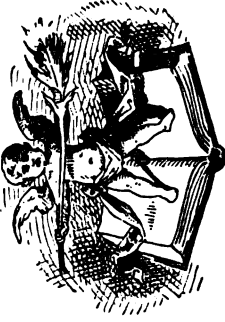

2055 60c.



2106 \$1.00.



2067 60c.



1964 40c.

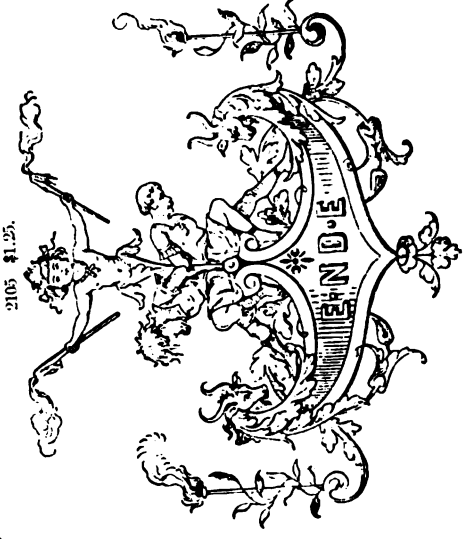

2105 \$1.25.



2049 60c.

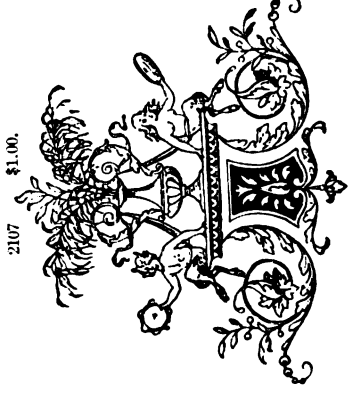

2107 \$1.00.

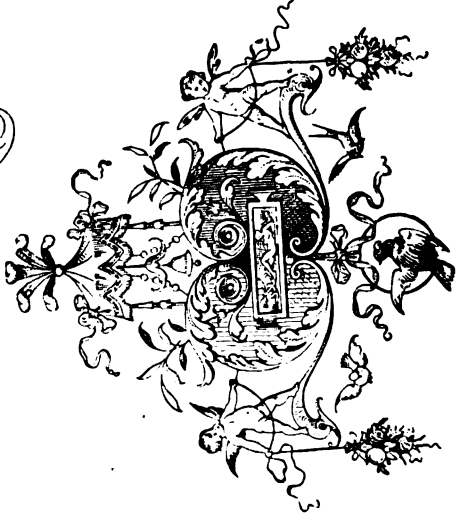

2103 \$1.25.

2074 60c.

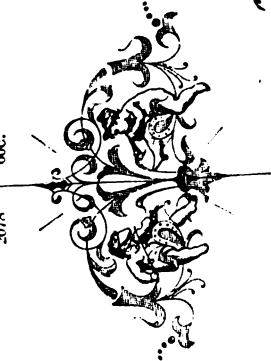

1962 50c.



1961 50c.



1963 50c.



2065 50c.



2046 50c.



2087 75c.



2097 \$1.00.



2081 60c.



2011 50c.



2101 \$1.25.



2100 \$1.25.

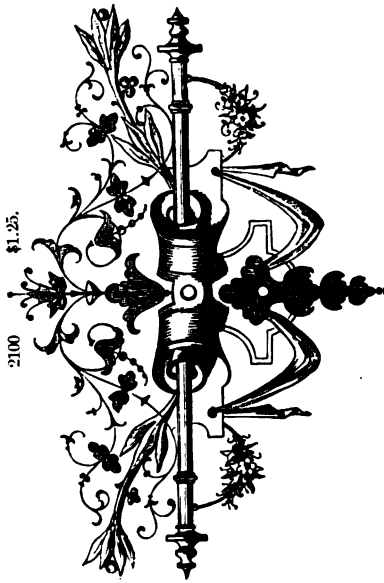

2104 \$1.25.



2023 \$1.25.

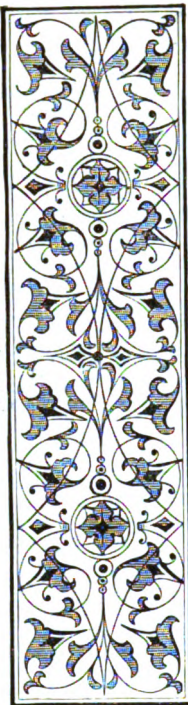

2027 \$1.25.

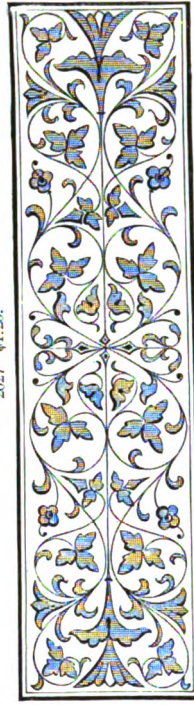

2021 \$1.25.

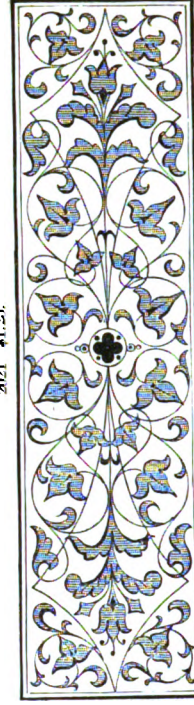

1888 75c.

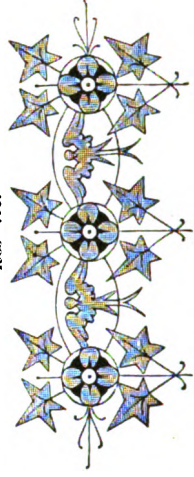

2008 60c.

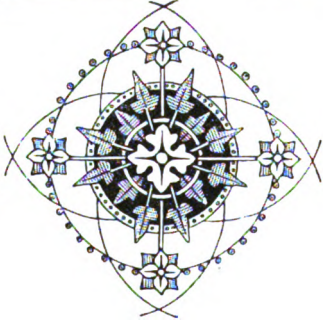

2082 60c.



2020 \$1.25.



2000 \$1.25.



1997 \$1.25.



1999 \$1.25.



1886 75c.

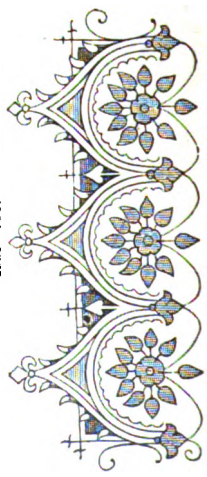

2005 40c.



2043 \$1.75.

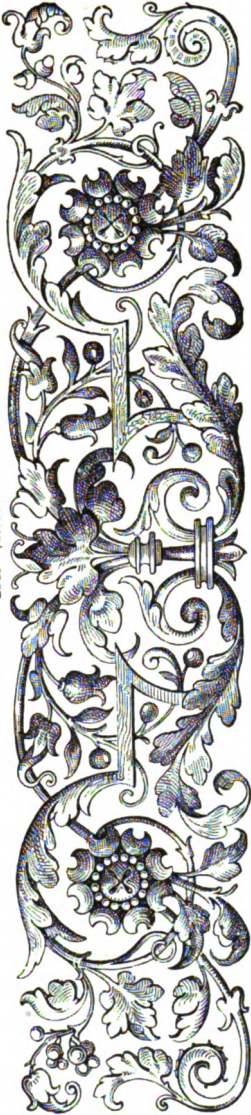

2003 40c.



2042 \$1.50.



2053 \$1.50.

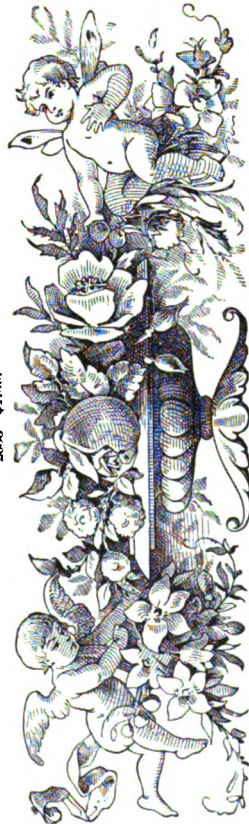

2006 40c.



2010 \$1.75.

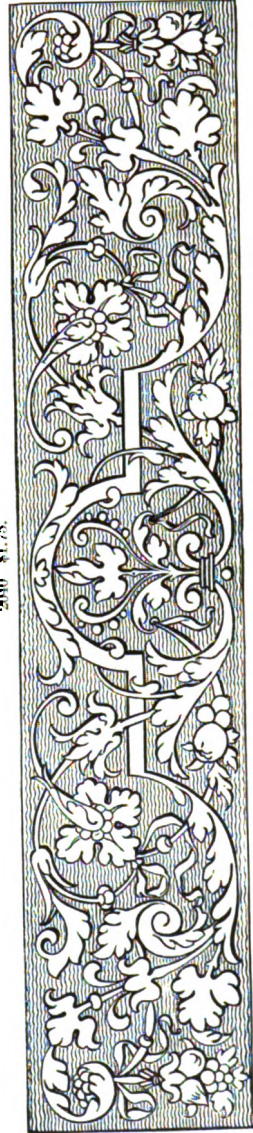

2004 40c.



2000 \$1.25.



2008 60c.

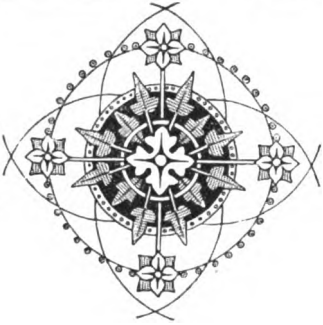

2023 \$1.25.



1997 \$1.25.



2082 60c.



2027 \$1.25.

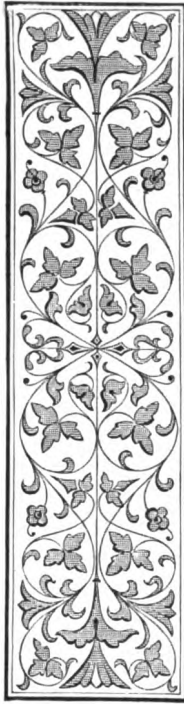

1999 \$1.25.



2021 \$1.25.

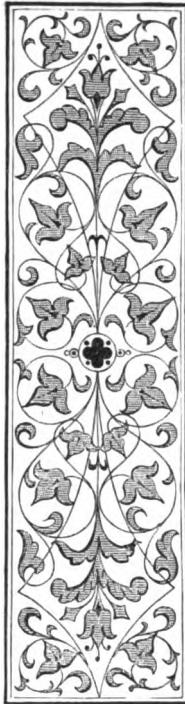

1986 75c.

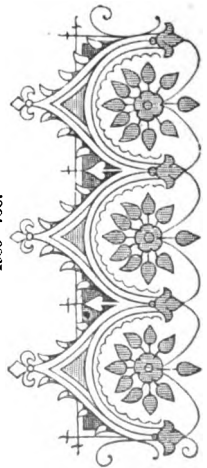

2029 \$1.25.



1988 75c.

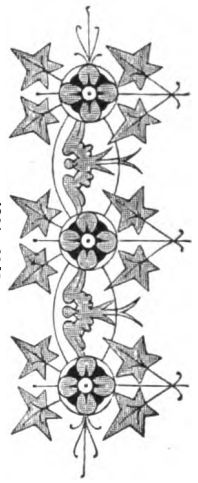

2003 40c.



2043 \$1.75.



2005 40c.



2053 \$1.50.

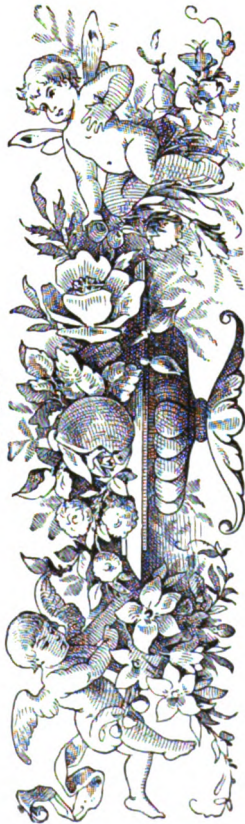

2042 \$1.50.



2004 40c.



2040 \$1.75.



2006 40c.



1904 \$1.00.



1887 50c.



1896 \$1.00.



1898 \$1.00.



1888 50c.



1901 \$1.00.



1902 \$1.00.



1910 50c.



1907 \$1.00.



1889 \$1.00.



1892 50c.



1905 \$1.00.



1899 \$1.00.



1893 50c.



1941 \$1.00.



1925 \$1.00.



1928 \$1.00.

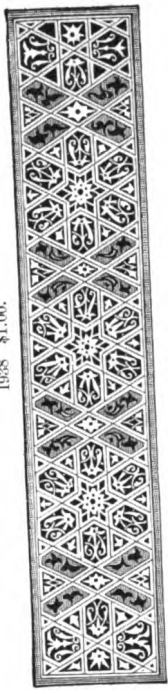

1946 \$1.00.



1996 \$1.00.



1949 \$1.00.



1912 30c.



1917 30c.



1913 30c.



1918 30c.



1915 30c.



1919 30c.



1916 30c.



1914 30c.



1950 \$1.00.

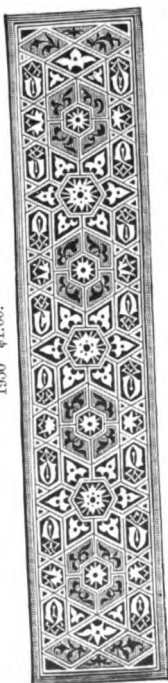

1945 \$1.00.

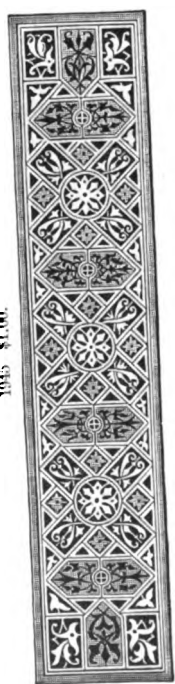

1942 \$1.00.



1932 \$1.00.



1933 \$1.00.



1921 75c.

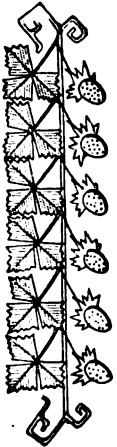

1923 75c.



1906 75c.



1956 75c.

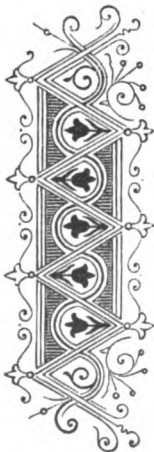

1905 \$1.25.



1937 75c.



1911 75c.



1922 75c.



1894 75c.



1895 75c.



1891 75c.



1897 75c.



1884 \$1.00.



1891 75c.



1882 \$1.00.



1903 75c.



1908 75c.



1900 75c.



2024 \$1.25.



2009 60c.



2010 60c.



2020 \$1.25.



2026 \$1.25.



2020 \$1.25.



2018 \$1.25.



1879 25c.



1880 25c.



1881 25c.



1882 25c.



1883 25c.



1884 25c.



1885 25c.



1886 25c.



1965 40c.



2034 \$1.75.



1963 40c.



2044 \$1.50.



2047 \$1.50.



2032 50c.



2041 \$1.75.



2031 50c.



2005 \$1.25.



1981 .50c.



2038 \$1.25.



2048 \$1.50.



2039 \$1.50.



2045 \$1.50.



2051 \$1.50.



CENTER PIECES.

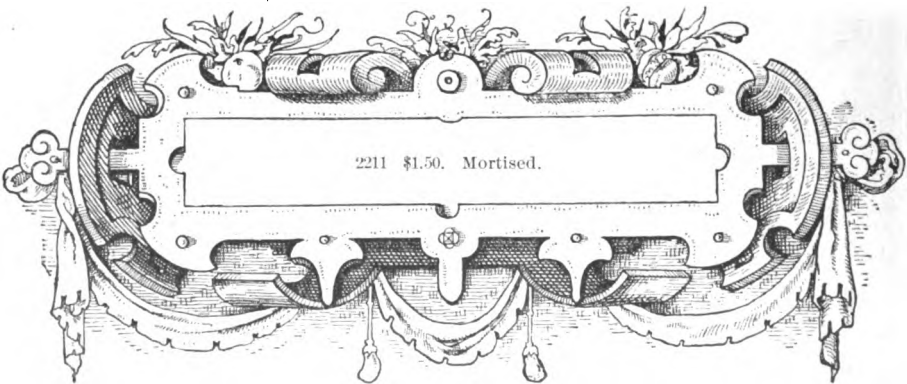
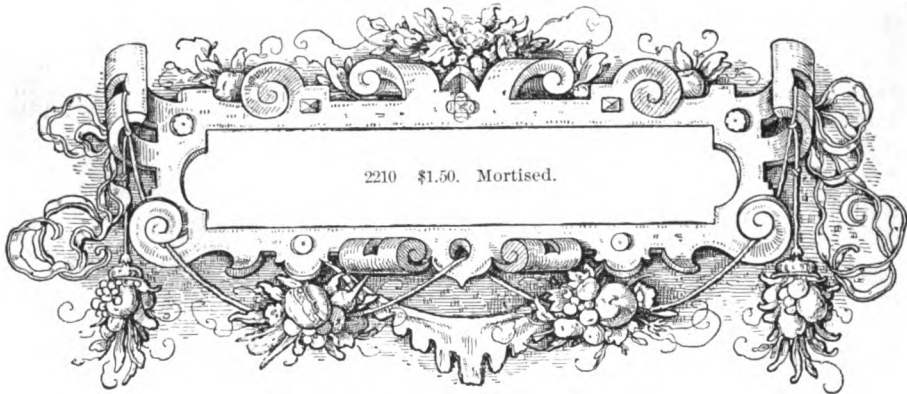

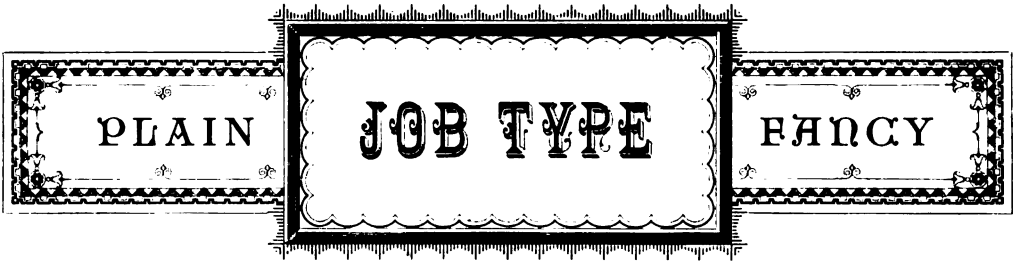

MISCELLANEOUS.

GT. PRIM. OLD STYLE NO. 3. (B.) 15 A, 30 a. \$5.00

Her Beautiful Face 86

DBL. SM. PICA OLD STYLE NO. 3. 12 A, 25 a. \$5.25

Market Report 3

DBL. GT. PRIM. OLD STYLE NO. 3. 8 A, 15 a. \$7.95

Stationer 3

FOUR-LINE PICA OLD STYLE NO. 3. 5 A, 8 a. \$8.00

Types 8

GT. PRIM. OLD STYLE. (B.) 15 A, 10 A, 30 a. \$5.00

Our Latest STYLES 86

DBL. SM. PICA OLD STYLE. 12 A, 8 A, 25 a. \$5.85

The Rubber BELT 5

DBL. ENGLISH OLD STYLE. 8 A, 6 A, 15 a. \$6.20

Best TYPES 7

DBL. GT. PRIM. OLD STYLE. 8 A, 6 A, 15 a. \$9.25

High Top 5

FOUR-LINE PICA OLD STYLE. 6 A, 4 A, 10 a. \$13.00

FERN 44

Hunters

NONPAREIL OLD STYLE TITLE
30 A, 52 a. Price, \$3.75.

COURTSHIP REGULATIONS
Only Silent and Hurried Kissing

MINION OLD STYLE TITLE. (J.)
25 A, 42 a. Price, \$3.85.

UNIVERSAL, MARTYRDOM
Fashion's Slavish Followers

BREVIER OLD STYLE TITLE.
25 A, 42 a. Price, \$3.90.

DUSTY TRAILING SKIRT
Inexpensive City Sweepers

BOURGEOIS OLD STYLE TITLE.
25 A, 42 a. Price, \$3.90.

MOONLIGHT COURTING
Evening Fortune-Hunting

LONG PRIMER OLD STYLE TITLE.
25 A, 42 a. Price, \$4.35.

ACTING TELEPHONES
Long-Distance Speakers

PICA OLD STYLE TITLE.
22 A, 32 a. Price, \$4.95.

HUMAN MONKEYS
Burlesque Mimicing

GT. PRIMER MAYENCE. (R.) 8 A, 4 A, 14 a. \$3.25

ENGLISH ROAD
Concert ELEVEN

DBL. PICA MAYENCE. 6 A, 4 A, 10 a. \$4.00

MEN HUNG
Seven DIMES

DBL. GT. PRIMER MAYENCE. 4 A, 3 A, 7 a. \$5.00

BENDERS
Stars HARE

CANON MAYENCE. 3 A, 2 A, 5 a. \$7.00

WORKS

Mad CUR

OLD STYLE ANTIQUE.

NONP. OLD STYLE ANTIQUE. (F.) 36 A, 70 a. \$2.85
CINCINNATI TYPE FOUNDRY
Printing Machinery of Every Description and
From all Makers 1883

BREVIER OLD STYLE ANTIQUE. 30 A, 50 a. \$3.00
COMMISSION MERCHANT
All Foreign and Domestic Productions
Receive Attention 1884

24 A, 50 a. LONG PRIMER OLD STYLE ANTIQUE. \$3.85
CELEBRATING AMERICAN INDEPENDENCE
Grand Lady Washington Entertainment and Old Folks' Concert
Costumes of Ye Olden Time 1882

18 A, 36 a. PICA OLD STYLE ANTIQUE. \$3.75
MODERN PHILANTHROPISTS
Political Candidates Before Election Day has Arrived
Extravagant Promises 1885

12 A, 24 a. GREAT PRIMER OLD STYLE ANTIQUE. \$4.10
AMERICAN BANKERS
Home Mutual Fire Insurance Company
Canadian Branch 1886

10 A, 16 a. DOUBLE SMALL PICA OLD STYLE ANTIQUE. \$4.75
ART JOURNAL 1887
Imported Summer Fashions

8 A, 12 a. TWO-LINE ENGLISH OLD STYLE ANTIQUE. \$6.00
THEATER 1889
Harmless Amusements

5 A, 10 a. TWO-LINE GREAT PRIMER OLD STYLE ANTIQUE. \$7.75
LEGION 86
Jacquiminot Rose

OLD STYLE EXTENDED.

NONP. OLD STYLE EXT. (Sl.) 24 A, 30 a. \$2.75
Instrumental Concert

VIOLINCELLO COMPOSITIONS
Complete Arrangement \$3

LG. PRIM. OLD STYLE EXT. 16 A, 16 a, 22 a. \$4.25

POPULAR AIRS
GARLAND OF SONG
Transcriptions 56

GT. PRIMER OLD STYLE EXT. 9 A, 9 a, 12 a. \$5.50

ANTHEM
TUNE BOOK
Quartette 4

BREVIER OLD STYLE EXT. 20 A, 16 a, 30 a. \$4.00

GENTLE MELODY
DANCES OF STRAUSS
12 Pretty Variations

PICA OLD STYLE EXT. 14 A, 14 a, 22 a. \$5.00

NEW OPERA
CONCERT GEMS
Piano Sonatas

DBL. PICA OLD STYLE EXT. 6 A, 6 a, 10 a. \$7.00

CHOIRS
UNITING
Oratorio

4 A, 4 a, 6 a.

DOUBLE GREAT PRIMER OLD STYLE EXTENDED.

\$8.50

80 SHEETS
MUSIC FOLIO
Harmony 9

4 A, 4 a, 6 a.

CANON OLD STYLE EXTENDED.

\$17.75

DELIGHT
INTENSE
Charm 8

Quads and Spaces extra.

100

Cincinnati Type Foundry, 201 Vine St.

OLD STYLE BOLD.

6-POINT OLD STYLE BOLD. (Sl.) 16 A, 22 a. \$3.00

AMERICAN INVENTOR
Finest Exhibition

8-POINT OLD STYLE BOLD. 16 A, 22 a. \$3.50

HOMESPUN CLOTH
Neat Garments

14 A, 18 a.

10-POINT OLD STYLE BOLD.

\$3.50

CHARMING HISTORICAL ACCOUNT
Mythological Narrative 36

12 A, 16 a.

12-POINT OLD STYLE BOLD.

\$4.00

MODERN ART FURNITURE
Improved Designs 250

7 A, 9 a.

18-POINT OLD STYLE BOLD.

\$4.50

MIDNIGHT CHARM
Dark Shades

5 A, 7 a.

24-POINT OLD STYLE BOLD.

\$6.00

LONG MARCH
Tramped 10

4 A, 6 a.

36-POINT OLD STYLE BOLD.

\$9.50

RED GOLD
Locketts

4 A, 6 a.

48-POINT OLD STYLE BOLD.

\$15.00

PIGEON
Nested

LIGHTFACE CHALLENGE.

NONPAREIL (6 POINTS) LIGHTFACE CHALLENGE.
25 A, 40 a. \$3.25 (B)

FINANCIAL DISASTERS
The Chances to Make Fortunes 67

3-LINE NONP. (18 POINTS) LIGHTF. CHALLENGE.
10 A, 15 a. \$4.50

STEAMER
The Ocean 5

BOURGEOIS (9 POINTS) LIGHTFACE CHALLENGE.
20 A, 30 a. \$3.75

OLD STYLE ITALIC
Suitable for Circulars 35

2-LINE NONP. (12 POINTS) LIGHTF. CHALLENGE.
15 A, 25 a. \$4.25

MACHINERY
Sweet Songsters 2

6 A, 10 a. FOUR-LINE NONPAREIL (24 POINTS) LIGHTFACE CHALLENGE. \$5.75

EUROPEANS
Russia and France 3

EMERALD No. 3.

NONP. EMERALD No. 3. (B) 20 A, 30 a. \$2.20
WAS WARRANTED NOT
To Break under any Strain 643

2-L. NONP. EMERALD No. 3. 10 A, 10 a, 15 a. \$4.05

BRIDGES
Sand Baggers
8 ROMEO 6

BREVIER EMERALD No. 3. 15 A, 15 a, 25 a. \$3.10

LOT OF STEEL
Pens that Sold Wholesale
25 THIRTY GROSS 83

LG. PRIM. EMERALD No. 3. 12 A, 12 a, 18 a. \$3.25

FESTIVALS
Michigan Railroad
5 KANSAS CITY 3

8 A, 8 a, 10 a. THREE-LINE NONPAREIL EMERALD No. 3. \$5.10

RACE HORSES
Western Newspaper
84 EXAMINED 48

6 A, 6a, 8 a. FOUR-LINE NONPAREIL EMERALD No. 3. \$6.60

NECK LACE
Beautiful Stairs
6 SHINE 3

FABRIC.

PICA FABRIC. (F) 15 A, 24 a. \$3.75
HIGHLAND ♦ HOUSE ♦ PARLORS
◀ Dramatic ♦ Entertainment ▶

Gt. PRIMER FABRIC. 10 A, 18 a. \$4.00
◀ LOCAL ♦ NEWS ▶
Leadville Bugle Horn 28

8 A, 12 a. TWO-LINE PICA FABRIC. \$4.75
◀ EVENING ♦ EXCURSION ▶
◀ Merchant ♦ Tailors ♦ Emporium ♦ 1882 ▶

LIGHTFACE LATIN ANTIQUE.

NONP. LIGHTF. LATIN ANT. (H) 25 A, 50 a. \$2.85
THE RUTLAND HERALD
Paper Made Entirely of Sawdust 78

BREVIER LIGHTFACE LATIN ANT. 25 A, 50 a. \$3.25
DAILY NEWSPAPER
Cunard Steamboat Lines 65

2-LINE NONP. LIGHTF. LAT. ANT. 15 A, 30 a. \$2.90
PEN INDUSTRY
Grown Wonderfully 4

Lg. PRIM. LIGHTFACE LATIN ANT. 18 A, 36 a. \$3.00
FIFTEEN YEARS AGO
Pens were all Imported 3

3-LINE NONP. LIGHTF. LAT. ANT. 10 A, 16 a. \$3.45
SUPPLIED
Four Officers 5

4-LINE NONP. LIGHTF. LAT. ANT. 8 A, 12 a. \$4.90
PEARS
Big Trees 3

6 A, 10 a. SIX-LINE NONPAREIL LIGHTFACE LATIN ANTIQUE. \$7.00
RAILROADS
Excursion Party 8

4 A, 5 a. EIGHT-LINE NONPAREIL LIGHTFACE LATIN ANTIQUE. \$8.00
HOUSES
Fresh Fruit 4

Quads and Spaces extra.

MISCELLANEOUS.

BREVIER CIRCULAR GOTHIC. 25 A, 25 A, 75 a. \$5.90
(B)
FURNITURE MANUFACTURERS

Magnificent and Fashionable Black Walnut
623 AND MAHOGANY FURNITURE 364

LG. PRIMER CIRC. GOTHIC. 20 A, 20 A, 50 a. \$4.55
ENGLISH DICTIONARY

Burns Byron and Longfellows Poems
34 NICELY BOUND IN CLOTH 57

PICA CIRCULAR GOTHIC. 15 A, 15 A, 40 a. \$4.85
EASTERN DEALERS

The Celebrated European Markets
489 TYPE FOUNDRY 438

NONPAREIL GROTESQUE GOTHIC. (B) 30 A. \$1.75
THE LANDING OF THE PILGRIMS AT PLYMOUTH
537 MONTH OF DECEMBER 824

BREVIER GROT. GOTHIC. 25 A, 25 A. \$2.90
STRANGERS AT THE WHITE MOUNTAINS
35 EASTERN SUMMER RESORT 36

LG. PRIMER GROT. GOTHIC. 20 A, 20 A. \$2.65
FIFTY ONE HUNDRED THOUSAND
453 PHOTOGRAPHS 657

PICA GROT. GOTHIC. 15 A, 15 A. \$2.80.
PRESIDENTIAL CAMPAIGN
493 NOVEMBER 587

GT. PRIMER GROT. GOTHIC. 12 A, 12 A. \$4.15
DOOR AND BLINDS
3 FACTORIES 5

DBL. PICA GROT. GOTHIC. 8 A, 8 A. \$3.65
ORNAMENTS
3 FLOWER 4

Quads and Spaces extra.

2-LINE NONPAREIL (12 POINTS) LIGHT ANGULAR.
14 A, 26 a. \$2.00 (B)

THE INVENTION OF
Paper in Eighteen Hundred 45

3-LINE NONPAREIL (18 POINTS) LIGHT ANGULAR.
10 A, 18 a. \$2.95

ENGRAVINGS
Chinese Traveler 28

4-LINE NONPAREIL (24 POINTS) LIGHT ANGULAR.
8 A, 14 a. \$3.25

SOCIETIES
Pine Buildings 5

6-LINE NONPAREIL (36 POINTS) LIGHT ANGULAR,
6 A, 10 a. \$5.00

SECOND
Shannon 3

LG. PRIMER LIGHT-FACE LYRIC. 15 A, 25 a. \$3.00
(B)

✦MANHATTAN✦BEACH✦
Flyers From all Stables Game

PICA LIGHT-FACE LYRIC. 12 A, 20 a. \$3.50

✦HIS✦WONDERFUL✦
Queen City Under Water

GT. PRIMER LIGHT-FACE LYRIC. 8 A, 14 a. \$4.25

✦MERRY✦RAFT✦
Beauties In Eighty

DBL. PICA LIGHT-FACE LYRIC. 5 A, 10 a. \$4.85

✦MOSCOW✦
Conclave Tight

TOCSIN CONDENSED.

PICA TOCSIN CONDENSED. (D) 8 A, 20 A. \$2.90

IMPROVED JOB PRESS
NONPAREIL PRINTING MACHINES
REGEDING-BED, \$225.00

GT. PRIMER TOCSIN CONDENSED. 6 A, 12 A. \$3.30

FIRE INSURANCE
DALTON TRUST COMPANY
SAFE DEPOSITS 423

5 A, 8 A.

DBL. PICA TOCSIN CONDENSED.

\$3.75

THE SOUTHERN RAILROAD
DIRECT CONNECTION WITH CHATTANOOGA

5 A, 6 A.

DBL. GREAT PRIMER TOCSIN CONDENSED.

\$5.75

LATEST SPECIMENS
THE CINCINNATI TYPE FOUNDRY

GEOMETRIC CONDENSED.

22 A, 30 a.

PICA CONDENSED GEOMETRIC. (St.)

\$3.75

FANCIES * EQUALLING * IN * DELICATENESS * THE * FLITTING * SNOWFLAKES
» Imagination's † Fancies ‹ \$1,234,567,890 » Entertaining † Daintiness ‹

22 A, 30 a.

GREAT PRIMER CONDENSED GEOMETRIC.

\$4.25

CHASTENESS * AND * PURITY * IN * LANGUAGE * DESIRABLE
» Uprightness † and † Sincerity † in † Speech † 1234 ‹

12 A, 16 a.

DOUBLE PICA CONDENSED GEOMETRIC.

\$4.00

GRACEFULNESS UNITED TO ELEGANCE
» Gratifying † the † Æsthetic † Senses † 79 ‹

9 A, 12 a.

DOUBLE GREAT PRIMER CONDENSED GEOMETRIC.

\$5.45

DELIGHTFUL * UNIQUENESS
» Charming † Novelties † 10 ‹

GEOMETRIC.

- 16 A, 16 a, 50 a. PEARL GEOMETRIC ON NONPAREIL BODY. (Sl.) \$3.50
BEAUTIFUL SUNSETS APPEARING TO AN ENRAPTURED OBSERVER OF NATURE
NOW THE HUSH OF TWILIGHT FALLS GENTLY ON THE GREEN AND SLOPING MEADOWS
All Tremulous the Aspens Stand by the Wayworn Zephyrs Fanned 150
Great Charms of Evening DEPARTURE OF THE SUNLIGHT Splendors of a Dying Day
- 16 A, 50 a. NONPAREIL GEOMETRIC. \$2.75
Handsome Series for Neat, Tasty and Elegant Printing
RESULT OF THE APPLICATION OF A NEW PRINCIPLE IN TYPE DESIGNING
Extremely Useful in Almost Every Style of Artistic Typography 345
- 16 A, 50 a. BREVIER GEOMETRIC. \$3.50
Letters Composed of Straight Lines and Angles 80
GRACEFUL FORMS OF SQUARES AND PARALLELOGRAMS
Beautiful Effect Produced Without Using the Line of Beauty
- 13 A, 40 a. LONG PRIMER GEOMETRIC. \$3.50
Mathematical Measurement 360
TREATISES ON THE PRINCIPLES OF GEOMETRY
Attributes and Relations of Magnitudes Found
- 12 A, 34 a. PICA GEOMETRIC. \$4.00
Many Intricate Computations 64
ARITHMETICAL QUESTIONS DISCUSSED
Investigating the Mysteries of Calculation
- 10 A, 24 a. GREAT PRIMER GEOMETRIC. \$4.50
Cornering the Round
STRANGE THEOREMS PROVED
Odd Tricks of Numbers 125
- 10 A, 15 a. DOUBLE PICA GEOMETRIC. \$5.00
Trying Problem
SQUARING A CIRCLE
Puzzles for Scholars

GEOMETRIC ITALIC.

- 16 A, 16 a, 50 a. PEARL GEOMETRIC ITALIC ON NONPAREIL BODY. (Sl.) \$3.50
*THE MELANCHOLY DAYS HAVE COME, THE SADDEST OF THE YEAR, WITH RUSTLING WINDS
SOFT AUTUMN BREEZES BLOW AND BEND THE RUSTLING GRASSES LOW VOICING MOURNFUL MELODIES.
Mournful Poems Bewailing Nature's Bleak, Dismal and Dejected Appearance
Gloomier: Feelings Aroused SPIRIT OF WEARINESS INDULGED Sadness of Verse Scribblers*
- 16 A, 50 a. NONPAREIL GEOMETRIC ITALIC. \$2.75
*Each Thought of the Woman that Loved him the Best and the Children
THREE FISHERS WENT SAILING OUT INTO THE WEST AS THE BRIGHT SUN WENT DOWN
Men Must Work and Women Must Weep, For There's Little to Earn and Many to Keep*
- 16 A, 50 a. BREVIER GEOMETRIC ITALIC. \$3.50
*Win Her With Gifts if She Respect Not Honeyed Words
GIFTS THEN SEEM MOST PRECIOUS WHEN THEIR GIVER WE ESTEEM
Dumb Jewels More Quick Than Words Do Move a Woman's Mind \$75*
- 13 A, 40 a. LONG PRIMER GEOMETRIC ITALIC. \$3.50
*Myriads of Birds all Piping Lays to Spring
BALMIEST SOUTH WINDS BLOW AND THE MEADOWS BLOOM
Describing Very Picturesque and Cheerful Landscapes 43*
- 12 A, 34 a. PICA GEOMETRIC ITALIC. \$4.00
*Kissed at Dawn by Tiniest Dew-Drops
SWEETEST FLOWERS GREETING THE SUNLIGHT
Welcoming with Blushes the Beautiful Morn 80*
- 10 A, 24 a. GREAT PRIMER GEOMETRIC ITALIC. \$4.50
*Quickly Vanishing Illusions
DREAMLAND SPLENDORS DISPELLED
Atmospheric Castles Demolished 16*
- 10 A, 15 a. DOUBLE PICA GEOMETRIC ITALIC. \$5.00
*Convenient Invention
PHONOGRAPHIC SYMBOLS
Manual of Short-Hand 25*

GEOMETRIC ANTIQUE.

18 A, 24 a. PICA (12 POINTS) GEOMETRIC ANTIQUE. (Sl.) \$3.25

Followed by Pedantic Comments
INDEPENDENCE DECLARATION READINGS
Opportunities for a Young Orator, July 4th

12 A, 16 a. GREAT PRIMER (18 POINTS) GEOMETRIC ANTIQUE. \$3.75

Anniversary Speeches
ORATIONS USED FOR PRACTICE
College Patriotism Exhibition

8 A, 10 a. DOUBLE PICA (24 POINTS) GEOMETRIC ANTIQUE. \$4.00

Enchanting Vision
MOONLIGHT GRANDEUR
Magical Brightness 570

4 A, 6 a. DOUBLE GREAT PRIMER (36 POINTS) GEOMETRIC ANTIQUE. \$5.00

Illuminated
CHARMING LIGHT
Gentlest Beams

4 A, 5 a. CANON (48 POINTS) GEOMETRIC ANTIQUE. \$8.00

RAMBLINGS
Enchanted 2

GEOMETRIC GOTHIC.

20 A, 30 a. PICA (12 POINTS) GEOMETRIC GOTHIC. (Sl.) \$3.25

**Refreshed Nature Smiles and Cheers Mankind
SAUCY ROBINS RENDER SWEET MORNING CAROLS
And Greet Us With Melodious Notes 36**

16 A, 20 a. GREAT PRIMER (18 POINTS) GEOMETRIC GOTHIC. \$3.75

**Lonely Pathways Found
COOL AND DEEP SECLUDED GROVES
Retreats for Poetic Mortals 320**

10 A, 15 a. DOUBLE PICA (24 POINTS) GEOMETRIC GOTHIC. \$4.00

**Superior Portraiture
PHOTOGRAPHIC CAMERAS
Pictures Truly Natural 48**

5 A, 8 a. DOUBLE GREAT PRIMER (36 POINTS) GEOMETRIC GOTHIC. \$5.00

**Sheet Music
CHORAL MAGAZINE
Harmonization 16**

4 A, 5 a. CANON (18 POINTS) GEOMETRIC GOTHIC. \$8.00

**MECHANISMS
Revolutions 5**

MISCELLANEOUS.

20 A, 108 a

PICA TYPE WRITER.* (ST.)

\$7.50

It is well-known that a Communication printed in this way receives much more attention than if printed with ordinary type, as the use of the Type-Writer has become general.

20 A, 100 a.

TWO-LINE NONPAREIL REMINGTON No. 2.* (B)

\$7.25

This font is cast on uniform body, and contains uniform spaces. The face has been cut as a fac-simile of the type used on Remington Type Writer No. 2.

100 A.

LONG PRIMER COPYGRAPH.* (F)

\$6.00

FOR COMMERCIAL CIRCULARS NOTHING COULD BE BETTER ADAPTED TO THE PURPOSE THAN THIS STYLE OF TYPE. PURPLE INK AND A ROUGH TYMPAN SHEET WILL ADD GREATLY TOWARD THE

PICA FASHION CONDENSED. (F) 18 A, 24 a. \$3.50

MUSICAL FRIENDS
Beautiful and Reliable Type

GT. PRIMER FASHION COND. 12 A, 18 a. \$4.00

FANCY CARDS
European Importation

DBL. PICA FASHION COND. 6 A, 10 a. \$5.00

FASHIONS
National Banker

DBL. GT. PRIM. FASHION COND. 5 A, 8 a. \$5.50

ADMIRER
Model Design

Quads and Spaces extra, except *

LONG PRIMER FASHION. (F) 18 A, 24 a. \$4.25

Fashionable Society. 27

PICA FASHION. 12 A, 16 a. \$4.50

Reduced Prices. 79

GREAT PRIMER FASHION. 8 A, 12 a. \$5.00

Grand Army 7

DBL. SMALL PICA FASHION. 6 A, 10 a. \$6.00

Union Line

GT. PRIMER LONDON. (B) 13 A. \$2.00

MORRISON MORSE

DBL. PICA LONDON. 10 A. \$3.00

ONE MISSION

DBL. GT. PRIMER LONDON. 8 A. \$4.00

MONARCH

BISQUE.

LONG PRIMER BISQUE. (B) 20 A. \$1.20
PALATIAL DIME MUSEUMS 365

PICA BISQUE. 15 A. \$1.20
MASQUERADE BALLS 435

GREAT PRIMER BISQUE. 15 A. \$2.05
THE ANARCHIST 34

DBL. SMALL PICA BISQUE. 12 A. \$2.25
LIMBER DICK 16

DBL. PICA BISQUE. 10 A. \$2.75
EXPLOSION 8

8 A. DBL. GREAT PRIMER BISQUE. \$3.85
BATTLE GROUNDS 34

6 A. SEVEN-LINE NONPAREIL (42 POINTS) BISQUE. \$4.10
DREAD ANARCHY 1

5 A. EIGHT-LINE NONPAREIL (48 POINTS) BISQUE. \$4.35
WARM RAINS 4

5 A. TEN-LINE NONPAREIL (60 POINTS) BISQUE. \$6.10
GUM SHOP 5

4 A. TWELVE-LINE NONPAREIL (72 POINTS) BISQUE. \$7.25
THE KIDS 3

FACADE.

NONPAREIL FACADE. (R) 36 A. \$1.50
MINSTREL COMBINATIONS WITH TRAVELLING MENAGERIES
◀SECURE YOUR SEAT EARLY. ONLY 35 CENTS▶

BREVIER FACADE. 30 A. \$1.75
LARGEST CONSIGNMENT OF HOUSEHOLD FURNITURE
◀289 MONUMENT AVENUE DORCHESTER▶

PICA FACADE. 22 A. \$2.25
PATENTED COLORED POTOGRAPHS
◀45 PER CENT. BOUGHT▶

LONG PRIMER FACADE. 26 A. \$2.00
SECURE THE ONLY CORRECT SOUVENIRS
◀OUR CALENDAR FOR 1887▶

16 A. GREAT PRIMER FACADE. \$2.75
WONDERFUL MACHINES FOR ENGRAVING PATTERNS
◀FIRST MUSICAL SOIREE DECEMBER 25▶

12 A. DBL. PICA FACADE. \$3.25
MEDICINE CAREFULLY COMPOUNDED
◀RESIDENCE 48 HOPE SQ.▶

8 A. DBL. GREAT PRIMER FACADE. \$1.00
REMARKABLE SITUATIONS
◀15 STEAM ENGINES▶

5 A. CANON FACADE. \$1.75
HONORD AMERICAN
◀138 HORSES▶

OBELISK.

2-LINE BREVIER OBELISK. (J) 10 A, 14 a. \$2.50

ELECTRIC LIGHTING

Lightning Freaks and Vagaries

5 A, 7 a.

2-LINE PICA OBELISK. 7 A, 10 a. \$3.20

GREEN FIELDS

Fifteen Hour Ramble

THREE-LINE PICA OBELISK.

\$5.15

BEAUTIFUL TWILIGHT

Amidst Crumbling Architecture

SENTRY.

TWO-LINE NONPAREIL (12 POINTS) SENTRY.

20 A, 30 a. \$3.25 (B)

THE RAILWAY AND MARINE

Insurance Companies of Georgia 275

SIX-LINE NONPAREIL (36 POINTS) SENTRY.

8 A, 12 a. \$5.50

NECKLACES

The Americans 5

THREE-LINE NONPAREIL (18 POINTS) SENTRY.

15 A, 25 a. \$3.80

CINCINNATI FOUNDRY

No 201 Vine Street Cincinnati

FOUR-LINE NONPAREIL (24 POINTS) SENTRY.

12 A, 18 a. \$4.50

SENTRY SERIES

Fine Condensed Face 3

5 A, 8 a.

EIGHT-LINE NONPAREIL (48 POINTS) SENTRY.

\$6.75

THE BRIGHT STARS

Mornings and Evenings 4

4 A, 6 a.

TEN-LINE NONPAREIL (60 POINTS) SENTRY.

\$7.85

BRIGHT Diamond 8

Quads and Spaces extra.

113

Cincinnati Type Foundry, 201 Vine St.

MISCELLANEOUS.

LONG PRIMER VULCAN. (B) 30 A. \$1.95

8 CHARMING MELODIES 9

PICA VULCAN. 20 A. \$2.15

MASSIVE ROCKS 3

GREAT PRIMER VULCAN. 12 A. \$2.50

4 OUR HOME 5

DOUBLE PICA VULCAN. 10 A. \$3.85

OLD MEN 4

DOUBLE GREAT PRIMER VULCAN. 6 A. \$4.20

2 ARMY

3-LINE EXCELSIOR KITCAT. (J) 12 A, 16 a. \$1.52

◀ EXERCISE & SPORT ▶

◀ Dealers · In · Trout · Fishing · Supplies ▶

PICA KITCAT. 10 A, 14 a. \$1.55

◀ MOWING · WHEAT ▶

Hard · Work · and · Good · Eating

3-LINE NONPAREIL KITCAT. 8 A, 12 a. \$2.45

◀ PLEASANT ▶

Steamboat · Excursion

TWO-LINE PICA KITCAT. 6 A, 8 a. \$2.85

◀ TURNIP ▶

Market Produce

THREE-LINE PICA KITCAT. 4 A, 5 a. \$1.15

Bear *and* Nut

FOUR-LINE PICA KITCAT. 3 A, 4 a. \$6.00

Peaches

Quads and Spaces extra.

PARAGON ALTONA. (R) 14 A, 20 a. \$3.50

HARRISON MARTINS
National Happiness

DBL. GT. PRIMER ALTONA. 6 A, 10 a. \$4.25

MANNERISMS
Hemisphere

CANON ALTONA. 5 A, 6 a. \$5.50

MERMAID
Neatest

PICA EPITAPH. (R) 14 A. \$2.25

PATENTED MEDICINES

GT. PRIMER EPITAPH. 10 A. \$2.50

HOUSE AND BARN

DBL. PICA EPITAPH. 7 A. \$3.25

MORE MEN

DBL. GT. PRIMER EPITAPH. 5 A. \$4.25

WOMAN

CANON EPITAPH. 3 A. \$6.00

HAMS

— OTHELLO. —

12 A, 18 a.

GREAT PRIMER OTHELLO. (Sl.)

\$3.25

GRIEVOUS MURDER OF DESDEMONA RECORDED
Doubting Othello Deceived by Iago 30

8 A, 12 a.

DOUBLE PICA OTHELLO.

\$4.00

REVENGEFUL MOORISH HUSBAND
Violent Emotions Aroused

6 A, 8 a.

DOUBLE GREAT PRIMER OTHELLO.

\$5.00

MOURNING SHROUS SOLU
Melancholy Raiment 12

6 A, 8 a.

CANON OTHELLO.

\$7.50

SHADOWS OF EREBUS
Gloomiest Abode

4 A, 5 a.

SIX-LINE PICA OTHELLO.

\$10.00

MODERN ROSES
Floriculture 8

MOSLEM.

DBL. ENGLISH MOSLEM. (R) 9 A, 14 a. \$3.75

MOUNTAIN SCENE
Sketch from Nature 3

DBL. PARAGON MOSLEM. 6 A, 10 a. \$4.50

SEA MINERS
Special Number 5

4 A, 6 a.

CANON MOSLEM.

\$5.50

RECORDED STATEMENTS
No. 86 Arch Avenue

TENIERS.

7 A, 7 a.

DBL. GREAT PRIMER TENIERS. (R)

\$4.00

SANDORSON AND BRIGHTMAN COMMISSION MERCHANTS
BRINGING 216 BEAUTIFUL DIAMOND RINGS

5 A, 5 a.

CANON TENIERS.

\$5.00

HARRISBURGH MODERN READING SCHOOL
HOUSE 38 HARRISON SQUARE

4 A, 4 a.

FIVE-LINE PICA TENIERS.

\$6.00

RICHARD'S MUSIC BOOKS 5

RUBENS.

DBL. PICA RUBENS. (R) 11 A, 15 a. \$4.25

Grand Dramatical Concert

DBL. GT. PRIMER RUBENS. 7 A, 11 a. \$5.00

North-Western Man

FIVE-LINE PICA RUBENS. 4 A, 6 a. \$7.50

Grand Mind

CANON RUBENS. 5 A, 7 a. \$6.00

Great America

DUERER.

11 A, 16 a.

GREAT PRIMER DUERER. (R)

\$3.25

RECORDS OF ROMANTIC RAMBLES IN ROCKWOOD

Second Edition Only 75 Cent per Volume

8 A, 11 a.

DBL. PICA DUERER.

\$4.00

NINETEENTH GRAND PERFORMANCE

Admission Tickets \$1.22 Each

5 A, 7 a.

DBL. GREAT PRIMER DUERER.

\$4.75

ORIGINAL GERMAN REPORT

Store 93 Benson Street

3 A, 4 a.

CANON DUERER.

\$6.00

MODERN REFORMS

Sends 45 Books

✦ HOGARTH ✦ SERIES ✦

3-LINE NONP. HOGARTH. (Sl.) 9 A. 14 a. \$3.50

DOUBLE PICA HOGARTH. 6 A. 8 a. \$4.60

✦ NEW KITES ✦

✦ ANCIENT ✦

Youthful ✦ Sport ✦ 64

Curious ✦ Build

4 A. 6 a.

THREE-LINE PICA HOGARTH.

\$5.50

GREAT ✦ BARGAINS

Closing Out at Cost \$50

4 A. 4 a.

FOUR-LINE PICA HOGARTH.

\$7.50

✦ JUNE ✦ DAY ✦

Picnic ✦ Excursion

4 A. 4 a.

SIX-LINE PICA HOGARTH.

\$16.50

AUCTION

Call Board 8

ART GOTHIC.

LONG PRIMER ART GOTHIC. (Sl.) 18 A, 28 a. \$2.75

Modern Poet Sentenced to be Hung
Song about Sweet Violets 36

PICA ART GOTHIC. 14 A, 20 a. \$3.00

Explorings in the Arctic Circle
Courageous Travelers

12 A, 16 a.

GREAT PRIMER ART GOTHIC.

\$3.00

Ambitious Individuals Scheming for Political Power
Secret Manipulations of Conventions 82

8 A, 10 a.

DOUBLE PICA ART GOTHIC.

\$4.00

Advancement of American Journalists
Enterprising Scholarship

6 A, 8 a.

THREE-LINE PICA ART GOTHIC.

\$5.00

Barquains in Spring Costumes
handsome Raiment 65

4 A, 5 a.

CANON ART GOTHIC.

\$6.50

Theoretical Philology

4 A, 5 a.

FIVE-LINE PICA ART GOTHIC.

\$9.20

Market Gardener

3 A, 5 a.

SIX-LINE PICA ART GOTHIC.

\$10.00

Find North Pole

VICTORIA.

- 36 A. NONPAREIL (6 POINTS) VICTORIA. (Sl.) \$2.25
* CORROBORATIVE + EVIDENCE + OF + INTRINSIC + WORTH + \$75 *
PERSONAL · REMINISCENCES · CONCERNING · EQUATORIAL · INVESTIGATING · JOURNEYS
- 28 A. BREVIER (8 POINTS) VICTORIA. \$2.50
* SUPERIOR + TYPOGRAPHIC + ACHIEVEMENTS + 28 *
UNCEASING · EFFORTS · OF · ENTERPRISING · PRINTERS · RECOGNIZED
- 20 A. LONG PRIMER (10 POINTS) VICTORIA. \$2.75
* WONDERFUL + CYCLOPAMA + 54 *
ILLUSIVE · EFFECTS · OF · ACCURATE · PERSPECTIVE
- 16 A. PICA (12 POINTS) VICTORIA. \$3.00
* RECENT · NEWS · 32 *
MORNING + AND + EVENING + GAZETTEER
- 12 A. ENGLISH (14 POINTS) VICTORIA. \$3.25
* FINE · OUTFITS · \$64 *
FASHIONABLE + IN + ADORNMENT
- 10 A. THREE-LINE NONPAREIL (18 POINTS) VICTORIA. \$3.50
* LOVES · BOYS · 15 *
GENTLE + SWEET + MAIDEN
- 8 A. TWO-LINE PICA (24 POINTS) VICTORIA. \$4.50
* PURCHASE · 8 *
MARKET + BASKETS
- 6 A. THREE-LINE PICA (36 POINTS) VICTORIA. \$6.75
* SERIES *
SOLD + CHAIRS

ATLANTA.

- 28 A. NONPAREIL (6 POINTS) ATLANTA. (SL.) \$2.25
* LUXURIOUS + EDITION, + VOLUME + 24 *
WEDDING · STATIONERY · PROGRAMMES · AND · FINE · ART · PRINTING
- 20 A. BREVIER (8 POINTS) ATLANTA. \$2.50
* HISTORICAL + DISCOVERIES + 36 *
ANTIQUARIANS · REWARDED · AND · ENCOURAGED
- 16 A. LONG PRIMER (10 POINTS) ATLANTA. \$2.75
* KITCHEN · SUPPLIES · 412 *
GROCERY + AND + PROVISION + MARTS
- 12 A. PICA (12 POINTS) ATLANTA. \$3.00
* BRILLIANT · 75 *
GRAND + MOONLIGHT + SCENE
- 9 A. ENGLISH (14 POINTS) ATLANTA. \$3.25
* INGREDIENT · 8 *
PREPARING + MEDICINES
- 8 A. THREE-LINE NONPAREIL (18 POINTS) ATLANTA. \$3.50
* CHORUS · 16 *
FINE + BASS + VOICE
- 6 A. DBL. PICA (24 POINTS) ATLANTA. \$4.50
* BOILING · 2 *
NEW + SUGARS
- 4 A. THREE-LINE PICA (36 POINTS) ATLANTA. \$6.75
* HEIR *
RICH · SON

WASHINGTON.

22 A, 32 a.	NONPAREIL (6 POINTS) WASHINGTON. (Sl.)	\$2.25
Handsome and Useful Holiday Presents with Purchases Amounting to \$12		
DOMESTIC CHRISTMAS FESTIVITIES UNIVERSALLY PARTICIPATED IN BY CIVILIZED NATIONS		
18 A, 24 a.	BREVIER (8 POINTS) WASHINGTON.	\$2.50
Gorgeous Byzantine Decoration of the Alhambra 57		
BRILLIANTLY HARMONIC MASSES OF RICH CORRUSCATING SPLENDOR		
16 A, 22 a.	LONG PRIMER (10 POINTS) WASHINGTON.	\$2.75
Full Dress Parade Every Wednesday at 6		
QUEEN CITY VOLUNTEER DARK INFANTRY HORSE CORPS		
12 A, 18 a.	PICA (12 POINTS) WASHINGTON.	\$3.00
Impressive Ceremonial Observance 83		
DISCOVERY OF OHIO BY POLITICUS ASPIRANTIA		
9 A, 13 a.	THREE-LINE NONPAREIL (18 POINTS) WASHINGTON.	\$3.50
Dance and Jig Music \$30		
TRIANGLE AND GUITAR NOTEBOOK		
8 A, 10 a.	DBL. PICA (24 POINTS) WASHINGTON.	\$4.50
Dealers in Lucifers 48		
GUILD OF MATCH MAIDS		
5 A, 7 a.	THREE-LINE PICA (36 POINTS) WASHINGTON.	\$6.75
Experience 56		
PRACTICAL WORK		
4 A, 5 a.	FOUR-LINE PICA (48 POINTS) WASHINGTON.	\$10.00
LOVED Fine 2		

JUMBO.

NONPAREIL (6 POINTS) JUMBO. 30 A. \$1.60
◀ BAITING + FOR + SUCKERS + 35 ▶

BOURGEOIS (9 POINTS) JUMBO. 25 A. \$1.80
SPRING + FLOWERS + 327

3-LINE NONP. (18 POINTS) JUMBO. 12 A. \$3.00
SPRINGS 8

2-LINE NONP. (12 POINTS) JUMBO. 20 A. \$2.15
◀ UNEARTHED + 5 ▶

8 A. FOUR-LINE NONPAREIL (24 POINTS) JUMBO. \$3.00
◀ FISHING + RODS + 5 ▶

6 A. FIVE-LINE NONPAREIL (30 POINTS) JUMBO. \$4.30
◀ FINE + SILK ▶ 5

5 A. SIX-LINE NONPAREIL (36 POINTS) JUMBO. \$4.75
THE + RIDE + 6

PEERLESS.

8 A, 12 a. DOUBLE PICA PEERLESS. (B) \$4.05
BRIDGEPORT
5 Elegant Bathing Costumes

6 A, 10 a. DOUBLE GREAT PRIMER PEERLESS. \$5.85
CREATORS
Nine Hundred Dollars 3

5 A, 8 a. DOUBLE PARAGON PEERLESS. \$6.45
PLEASURE
7 Croquet Ground

✧ LYRIC ✧ SERIES ✧

PICA LYRIC. (B) 12 A, 20 a. \$3.50

✧ GOVERNMENTS ✧

France ✧ and ✧ Germany.
European 1872

GREAT PRIMER LYRIC. 8 A, 14 a. \$4.25

✧ GENERALS ✧

American ✧ FORGES.
War of 1812

5 A, 10 a.

DBL. PICA LYRIC.

\$4.85

✧ NORTHERN LIGHT ✧

Display of the Aurora Borealis
Sunday, April 19

DART SERIES.

TWO-LINE NONPAREIL DART. (P) 18 A. \$2.00

✧ OPENING ✧ OF ✧ SPRING ✧
✧ BONNETS ✧ AND ✧ FLOWERS, ✧
MILLINERY ✧ GOODS

THREE-LINE NONPAREIL DART. 14 A. \$2.75

HE FOLLOWETH
THE ✧ LIGHT ✧ OF ✧ LIFE
IN DARKNESS

10 A.

FOUR-LINE NONPAREIL DART.

\$2.95

✧ COMMERCIAL ✧ BULLETIN ✧
THE ✧ INDEPENDENT ✧ MERCHANTS
CORN EXCHANGE

5 A.

SIX-LINE NONPAREIL DART.

\$3.00

UNITED ✧ STATES
✧ PATRIOTIC ✧ DISPLAYS ✧

Quads and Spaces extra.

124

Cincinnati Type Foundry, 201 Vine St.

ROCOCO SERIES.

10 A, 10 A.

GREAT PRIMER ROCOCO. (St.)

\$4.65

DURABLE *  * PLEASING * 92
PRINTING * TYPES * AND * PRESSES
BEST MAKES *  64  * NEW STYLES

8 A, 8 A.

DOUBLE PICA ROCOCO.

\$5.85

ADVANCEMENT 46
DESIGNING *  * FOUNDING
ARTISTIC * WORKMEN * 25

5 A, 5 A.

DOUBLE GREAT PRIMER ROCOCO.

\$6.25

DELIGHTFUL
SPECIMEN * SHEETS
NEWER * CHARMS * 38

4 A, 4 A.

CANON ROCOCO.

\$9.75

GRAND MARCH
SUPREMACY * 2

MISCELLANEOUS.

2-LINE NONP. (12 POINTS) DOTTED. (B) 20 A. \$1.40
THE DOTTED SERIES 352

3-LINE NONP. (18 POINTS) DOTTED. 15 A. \$2.10
UNITED STATES 45

4-LINE NONP. (24 POINTS) DOTTED. 10 A. \$2.50
ALDERMEN 4

5-LINE NONP. (30 POINTS) DOTTED. 8 A. \$2.90
ANCHOR 6

6-LINE NONP. (36 POINTS) DOTTED. 6 A. \$3.80
STAND 3

PICA DADO. (J) 12 A, 18 a. \$2.55

→ **ATHLETIC + SPORTS** ←

→ **Amusement + of + the + Oldtime** →

TWO-LINE BREVIER DADO. 10 A, 14 a. \$3.15

→ **PROTRACTED** ←

→ **Journeying + to + Oblivion** →

TWO-LINE PICA DADO. 7 A, 10 a. \$4.05

→ **MODERN** ←

→ **Curiosity + Shop** →

TWO-LINE GREAT PRIMER DADO. 5 A, 8 a. \$5.45

→ **BLUE** ←

→ **Barbarian** →

Quads and Spaces extra.

NONPAREIL CULDEE. (J) 12 A, 24 a. \$2.55

→ **Autumnal Meeting** ←
Inauguration of Boreal Association

3-LINE EXCELSIOR CULDEE. 10 A, 20 a. \$2.80

→ **Novel Schemes** ←
Lessons in Outdoor Manners

PICA CULDEE. 8 A, 16 a. \$3.25

→ **Partnership** ←
Swindler and Company

3-LINE NONPAREIL CULDEE. 5 A, 10 a. \$3.80

→ **National** ←
Healthy Suburbs

TWO-LINE PICA CULDEE. 4 A, 8 a. \$4.60

White + Cash

TWO-LINE NONPAREIL (12 POINTS) BREVET.

10 A, 20 a. \$2.75 (B)

THE SUN AROSE

Very Early in the Morning 23

THREE-LINE NONPAREIL (18 POINTS) BREVET.

8 A, 16 a. \$3.75

COUNTRIES

Egypt and Europe 46

FOUR-LINE NONPAREIL (24 POINTS) BREVET.

5 A, 10 a. \$3.90

DESIGNER

Our Neighbor 45

SIX-LINE NONPAREIL (36 POINTS) BREVET.

4 A, 6 a. \$5.10

BEARDS

The Horse 5

Cincinnati Type Foundry, 201 Vine St.

PANSY AND OLIVE.

TWO-LINE NONPAREIL (12 POINTS) PANSY.
8 A, 14 a. \$2.15 (B)

OUR GREAT MIKADO
Began to Rule the Land 76

THREE-LINE NONPAREIL (18 POINTS) PANSY.
6 A, 10 a. \$2.65

SUPERIOR
Type Foundries 54

FOUR-LINE NONPAREIL (24 POINTS) PANSY.
5 A, 8 a. \$3.90

DIAMONDS
Shine Bright 3

SIX-LINE NONPAREIL (36 POINTS) PANSY.
4 A, 6 a. \$5.25

GREAT
General 2

TWO-LINE NONPAREIL (12 POINTS) OLIVE.
8 A, 14 a. \$2.25 (B)

LEAVES AND BARK
Office of Doolittle & Co 64

THREE-LINE NONPAREIL (18 POINTS) OLIVE.
6 A, 10 a. \$3.00

CELEBRATED
Fine Corn Beef 35

FOUR-LINE NONPAREIL (24 POINTS) OLIVE.
5 A, 8 a. \$4.00

PRIVATE
The Salt Lake 2

SIX-LINE NONPAREIL (36 POINTS) OLIVE.
4 A, 6 a. \$5.90

RANGE
New Year 4

SPENSER.

2-LINE NONP. (12 POINTS) SPENSER. (B) 20 A. \$1.40

◀ AMERICAN PEOPLE ▶ 23

3-LINE NONP. (18 POINTS) SPENSER. 15 A. \$2.25

STREET GUIDES 4

5-LINE NONP. (30 POINTS) SPENSER. 8 A. \$3.35

POUNDS 3

4-LINE NONP. (24 POINTS) SPENSER. 10 A. \$2.80

CENTURIES 6

6 A.

SIX-LINE NONPAREIL (36 POINTS) SPENSER.

\$4.00

◀ RUSTY BARS ▶ 5

Quads and Spaces extra.

127

Cincinnati Type Foundry, 201 Vine St.

MISCELLANEOUS.

PICA CLEMATIS. (B) 10 A, 25 a. \$3.20

MORRIS & RANSOM

Very Good Display of Chromos 34

GT. PRIMER CLEMATIS. 8 A, 20 a. \$4.00

WORK & PLAY

Ideal Opera Company 45

DBL. PICA CLEMATIS. 6 A, 14 a. \$5.70

EASTERN

Beautiful Stars 8

TWO-LINE NONPAREIL (12 POINTS) EMPIRE.
15 A, 25 a. \$2.75 (B)

EDITIONS PUBLISHED

Heavily Subscribers Daily Received 8

THREE-LINE NONPAREIL (18 POINTS) EMPIRE.
10 A, 15 a. \$3.60

CHESTNUT JOKES

By Political Candidates 6

FOUR-LINE NONPAREIL (24 POINTS) EMPIRE.
8 A, 12 a. \$4.40

KNOWLEDGE

Deserted Claims 3

SIX-LINE NONPAREIL (36 POINTS) EMPIRE.
5 A, 8 a. \$5.50

WOLVES

The Pacific 5

Quads and Spaces extra.

PICA BIJOU. (J) 12 A, 32 a. \$4.55

Hegelian Blowhard's Opportunity
1234567890

THREE-LINE NONP. BIJOU. 8 A, 20 a. \$5.35

Honestly Recommend * 9

TWO-LINE PICA BIJOU. 6 A, 14 a. \$5.75

21. Civil Reformers

TWO-LINE NONPAREIL (12 POINTS) ASTEROID.
15 A, 25 a. \$2.75 (B)

THE AUDITORIUM WAS

Overwhelmingly Crowded with the Elite 72

THREE-LINE NONPAREIL (18 POINTS) ASTEROID.
10 A, 15 a. \$3.00

THE CORPORATION

Denouncing the Legislation 3

FOUR-LINE NONPAREIL (24 POINTS) ASTEROID.
8 A, 12 a. \$3.75

THE MOVEMENT

Existence is Possible 2

FIVE-LINE NONPAREIL (30 POINTS) ASTEROID.
6 A, 10 a. \$4.25

RECOLLECTION

Many Happy Days 4

SIX-LINE NONPAREIL (36 POINTS) ASTEROID.
5 A, 8 a. \$5.00

RETURNS

Time Cometh 3

ANTLER.

TWO-LINE NONP. ANTLER. (B) 12 A, 18 a. \$2.15

⇒PRINTERS MACHINERY←

Office of the Cincinnati Type Foundry
23456789

THREE-LINE NONP. ANTLER. 10 A, 14 a. \$2.40

⇒STATE OF OHIO←

The Country Newspaper 5

7 A, 10 a.

FOUR-LINE NONPAREIL ANTLER.

\$3 10

⇒SIOUX INDIAN LODGE←

Man is Only Happy Within the Silent Grave 65

5 A, 7 a.

SIX-LINE NONPAREIL ANTLER.

\$4 10

⇒PIONEERS OF INDIANA←

Elegant Grapes from the Vine Yard 35

ANGULAR.

TWO-LINE NONP. ANGULAR. (B) 14 A, 26 a. \$2.00

SUPREME COURTS

The Thomson Opera Company
2345678

THREE-LINE NONP. ANGULAR. 10 A, 18 a. \$2.95

ENGRAVING

Chinese Traveler 43

8 A, 14 a.

FOUR-LINE NONPAREIL ANGULAR.

\$3 25

STARS AND STRIPES

2 Sailing on the Grand Ohio River

6 A, 10 a.

SIX-LINE NONPAREIL ANGULAR.

\$5 00

UNITED STATES

Central Railroad Line 4

MISCELLANEOUS.

PICA MYSTIC. (R) 16 A. \$2.00

→ CINCINNATI * FOUNDRY ←

GT. PRIMER MYSTIC. 12 A. \$2.25

◁ ARTISTIC * SERIES ▷

DBL. SMALL PICA MYSTIC. 9 A. \$2.50

→ FAST * MEN ←

DBL. ENGLISH MYSTIC. 7 A. \$3.00

HARD TIMES

DBL. PARAGON MYSTIC. 5 A. \$4.00

AMERICA

NONPAREIL EASTLAKE. (J) 30 A. \$1.90

< DESIRES * OF * AMBITIOUS * YOUTHS * 784 >

BREVIER EASTLAKE. 22 A. \$2.00

◁ 2950 * RARE * TROPICAL * PLANTS ▷

LONG PRIMER EASTLAKE. 22 A. \$2.20

◁ 63 * RAILROAD * MONARCHS ▷

PICA EASTLAKE. 16 A. \$2.20

◁ MINSTREL * JOKES * 85 ▷

GREAT PRIMER EASTLAKE. 10 A. \$2.30

◁ 31 * GRAIN * BAGS ▷

DOUBLE PICA EASTLAKE. 7 A. \$2.80

◁ PEARS * 46 ▷

DBL. GREAT PRIMER EASTLAKE. 5 A. \$3.80

→ 8 * RAT ←

Quads and Spaces extra.

LG. PRIM. NORMANESQUE. (B) 20 A. \$1.35

THE * STORMY * PARLIAMENTS

PICA NORMANESQUE. 15 A, 15 A. \$2.25

HIGH * LIFE * IN * THE * DARK
→ BROWN RATS ←

GT. PRIM. NORMANESQUE. 12 A, 12 A. \$2.60

POEMS * OF * EUROPE
STEEL POINTS

DBL. SM. PICA NORMANESQUE. 10 A, 10 A. \$3.25

HIGH * AND * DRY
→ HANDSOME ←

DBL. PICA NORMANESQUE. 8 A, 8 A. \$3.50

ON * THE * SUN
→ SEE GLEN ←

DBL. GT. PRIMER NORMANESQUE. 6 A, 6 A. \$4.75

→ RUINS ←
GARBLED * 92

PICA MURAL. (R) 14 A. \$2.25

MORNINGS AND EVENINGS

GT. PRIMER MURAL. 10 A. \$2.50

◁ GRENADIER ▷

DBL. PICA MURAL. 7 A. \$3.25

DORE AND SON

DBL. GT. PRIMER MURAL. 5 A. \$4.25

MORGAN

MISCELLANEOUS.

TWO-LINE NONPAREIL (12 POINTS) SUPERIOR.
18 A. \$1.75 (B)

CINCINNATI TYPE FOUNDRY 524

THREE-LINE NONPAREIL (18 POINTS) SUPERIOR.
12 A. \$2.10

AVERAGE WEIGHT 78

FOUR-LINE NONPAREIL (24 POINTS) SUPERIOR.
10 A. \$2.60

TOMBSTONES 3

SIX-LINE NONPAREIL (36 POINTS) SUPERIOR.
6 A. \$3.05

OHIO RIVER 3

3-LINE EXCELSIOR CRUIKSHANK. 10 A, 28 A. \$2.70
(J)

NEEDED RENOVATIONS
PROTECTION FOR HOME INDUSTRIES

PICA CRUIKSHANK. 10 A, 28 A. \$3.30

CORRECTIVE METHOD
PROPOSED NATIONAL REFORM

3-LINE NONPAREIL CRUIKSHANK. 6 A, 14 A. \$3.85

CONSTABLES
SHOWING KINDNESS

2-LINE PICA CRUIKSHANK. 5 A, 12 A. \$4.65

POLITICAL
OFFICE SEEKER

5-LINE NONPAREIL CRUIKSHANK. 4 A, 8 A. \$5.15

COLLECTIONS

3-LINE PICA CRUIKSHANK. 3 A, 6 A. \$5.80

PRESIDENT

Quads and Spares extra.

GT. PRIMER CARD GOTHIC. (F) 10 A, 8 A, 36 a. \$6.50

SPECTACULAR 84
Fine Typographic Combinations

2-LINE PICA CARD GOTHIC. 6 A, 8 A, 25 a. \$6.75

ELEGANT 85
Cincinnati Printing Houses

2-LINE GT. PRIM. CARD GOTH. 5 A, 4 A, 16 a. \$8.60

TYPOS 84
Artistic Printerdom

PICA ELITE. (B) 10 A, 25 a. \$3.00

CHEERFUL LITTLE BABIES
Straips of Youthful Harmonies 4

GREAT PRIMER ELITE. 8 A, 20 a. \$3.80

GREAT DIME MUSEUM
5 Original Comical Stories

DOUBLE PICA ELITE. 6 A, 14 a. \$4.80

NEW FANGY TOY
Sweet and Modest 7

PICA RENAISSANT. (D) 10 A, 16 a. \$2.80

ORNAMENTAL
Diamonds * and * Specimens * 47

GT. PRIMER RENAISSANT. 8 A, 12 a. \$2.80

INTEGRITY
Universal * Financial * 9

TWO-LINE SMALL PICA RENAISSANT.
6 A, 10 a. \$3.40

PAINTING
Superior * Stand * 5

MISCELLANEOUS.

LONG PRIMER YORK. (F) 12 A, 50 a. \$4.25
 YORK CATHEDRAL:
 The 13th Century Erected it was

PICA YORK. 10 A, 36 a. \$4.50
 YERK TOWN
 Defeats of Lord Cornwallis

3-LINE NONPAREIL YORK. 8 A, 24 a. \$5.75
 NEW YORK,
 City of Empire State

PICA HEROIC. (F) 12 A, 30 a. \$2.75
 HEROIC DEEDS
 Olden Times from 1376

3-LINE NONPAREIL HEROIC. 8 A, 16 a. \$3.50
 RECORD
 Heroic Deeds '65

2-LINE PICA HEROIC. 6 A, 12 a. \$4.00
 ANCESTOR
 Our Hero

THREE-LINE NONP. ROMANIC. (F) 5 A, 8 a. \$4.25
 PRINTING
 Artistic Jobs 5

TWO-LINE PICA ROMANIC. 4 A, 6 a. \$4.25
 CHOICE
 Fine Date 2

PICA CIRCLET. (B) 10 A. \$2.75
 CLOSE BANK

GREAT PRIMER CIRCLET. 8 A. \$3.25
 REGIONS

DBL. SMALL PICA CIRCLET. 6 A. \$3.50
 RID PIN

Quads and Spaces extra.

NONPAREIL OXONIAN. (J) 14 A, 24 a. \$2.15
 STANDARD CYLINDER AND JOB PRESSES
 GINGINATI TYPE FOUNDRY, NO. 201 VINE STREET

BREVIER OXONIAN. 12 A, 20 a. \$2.30
 ORIENTAL LITERARY RECORD
 FRENCH MAGAZINES AND PERIODICALS

LONG PRIMER OXONIAN. 10 A, 20 a. \$2.50
 BOARD OF EDUCATION
 BRYANT COMMERCIAL ACADEMY

PICA OXONIAN. 10 A, 18 a. \$3.05
 PAPAN STRUCTURES
 SPRINGTIME RAMBLES 1324

GREAT PRIMER OXONIAN. 8 A, 14 a. \$3.70
 TYPE FOUNDRY
 RELIABLE JOB PRESS

TWO-LINE LG. PRIMER OXONIAN. 7 A, 12 a. \$3.95
 NEW STYLES
 ELEGANT DESIGNS

TWO-LINE PICA OXONIAN. 5 A, 10 a. \$4.25
 COMPANIES
 MESSAGE BOY 3

LONG PRIMER ETHIC. (B) 20 A, 30 a. \$3.75
 TWENTY EIGHT
 White Elephants Stolen 25

PICA ETHIC. 20 A, 25 a. \$4.00
 UNIVERSITY
 Great Discoveries 45

GREAT PRIMER ETHIC. 10 A, 15 a. \$4.50
 KINGDOM
 City Bridges 33

DBL. PICA ETHIC. 6 A, 10 a. \$5.25
 SHORE
 Lake Erie 8

132

Cincinnati Type Foundry, 201 Vine St.

MISCELLANEOUS.

Lg. PRIMER (10 POINTS) APOLLO. 14 A. 32 a. \$3.25
(St.)

ELEGANT MILLINERY

Our new styles for 1887-88 have just arrived from Paris direct by way of the K. C. Ry. and will be sold to the lowest bidder, regardless of cost, our agents having procured them without trouble in the absence

2-LINE NONP. (12 POINTS) APOLLO. 12 A, 28 a. \$3.50

SCHOOL OF DESIGN

The curriculum of this institution will positively make a designing person of any young lady in the shortest space of time at the nominal sum of \$98

9 A, 18 a.

THREE-LINE NONPAREIL (18 POINTS) APOLLO.

\$4.00

BRETHREN OF CONFUSCIUS

A Special Meeting will be held on Jossday, to confer the Washeewashee degree on 218 Squirter, or first degree members of the above noble fraternity

10 A, 15 a.

FOUR-LINE NONPAREIL (24 POINTS) HERMES. (St.)

\$4.50

THE CINCINNATI TYPE FOUNDRY

New Series of Unique Old Style Borders 4
Elegant Addition to Typography

4 A, 6 a.

EIGHT-LINE NONPAREIL (48 POINTS) JUPITER. (St.)

\$7.00

NATIVE WINES

❖ Adulterated ❖

Concord ❖ Grapes ❖ 38

Quads and Spaces extra.

133

Cincinnati Type Foundry, 201 Vine St.

✂ SIGN ET. ✂

12 A, 24 a. THREE-LINE EXCELSIOR SIGNET. (7) \$2.10

Gircignati, on the Ohio, December 25th, 1885
 The Mantle of Night with its shadowy folds, draped the landscape in black obscurity,
 While from the distant echoing hill came the wierd plaint of whip-poor-will
 Reverberating through the misty vales.
 ↳ Rocksplitter Moses & Company, 2451 Desert Place.

10 A, 20 a. PICA SIGNET. \$2.70

Richardson's Patent Carbon Mixing Tool
 While with fierce gusts Old Boreas blew his breath, and angry rose
 the whelming waves of death.
 ↳ Rangeabout Gadover & Company, \$1,654 Cash.

8 A, 16 a. THREE-LINE NONPAREIL SIGNET. \$3.85

Down by the Old Garden Gate
 I wandered by, too late to meet my pretty mate
 No. 1364 Apple Lane
 ↳ Romulus & Remulous, Founders, &c.

6 A, 12 a. TWO-LINE PICA SIGNET. \$4.40

May will return in 1885
 That is if this Small Planet does survive
 The Whirligig of Time
 ↳ Received this day, \$1,246.

4 A, 8 a. THREE-LINE PICA SIGNET. \$6.60

Political Bickerings
 Hurt Trades \$63,145,000
 ↳ Rough but True.

ARTISTIC SERIES.

10 A, 16 a.

PICA ARTISTIC. (D)

\$2 80

❧ EUREKA ❧ STEAM ❧ PRINTING ❧ WORKS ❧

Colored Labels, Show Cards ❧ 326 ❧ Programmes, Receipts, Checks
Designers ❧ Engravers ❧ Lithographers

8 A, 12 a.

GREAT PRIMER ARTISTIC.

\$2 80

❧ THE ❧ CINCINNATI ❧ GYMNASIUM ❧

❧ Rare Exhibitions of Muscular Developments ❧
Famous American Athletes 86

6 A, 10 a.

DBL. SMALL PICA ARTISTIC.

\$3 40

❧ BRONZE ❧ STATUES ❧

Artistic ❧ Parlor ❧ Mantle ❧ Decorations
Fancy Pottery, 354

RHOMBIC SERIES.

LONG PRIMER RHOMBIC. (C) 15 A, 40 a. \$2.15

GREAT MARRYTOWN
Morning and Night Time 12

DBL. PICA RHOMBIC. 10 A, 15 a. \$4.60

CONSCIOUS
Searching of ❧

PICA RHOMBIC. 15 A, 25 a. \$2.40

HONEST, WORTHY,
Now found with trust 25

GT. PRIMER RHOMBIC. 12 A, 18 a. \$3.30

MERYTORIOUS
The Catastrophe 15

4 A, 8 a.

DOUBLE GREAT PRIMER RHOMBIC.

\$4.75

FAITHFULNESS

Through sunshine 23

Quads and Spaces extra.

135

Cincinnati Type Foundry, 201 Vine St.

MISCELLANEOUS.

8 A, 16 a. DOUBLE SMALL PICA ACADIAN No. 3. (T) \$3.70
DREAM OF UTOPIAN BLISS
Peaceful Cultivation of Native Works of Beauty 123

6 A, 12 a. DOUBLE PICA ACADIAN No. 3. \$4.50
THE QUIET READER
Never is Conspicuous in Street Fights 23

4 A, 8 a. FIVE-LINE NONPAREIL ACADIAN No. 3. \$5.05
PEACE AND REST
The Fruits of Living Proper \$8

12 A, 12 A. GREAT PRIMER ACADIAN No. 2. (T) \$4.80
SHEPHERDS AND SHEPHERDESSES
DROWSILY KEEPING WATCH OVER THEIR FLOCKS
↔ † 1234 123456 7890 * ↗

10 A, 10 A. DOUBLE SMALL PICA ACADIAN No. 2. \$6.00
SNOW-CAPPED MOUNTAINS
WERE THE MOST VISIBLE FEATURES
↔ † 1234 1234 5678 * ↗

8 A, 8 A. DOUBLE PICA ACADIAN No. 2. \$6.65
DELINO'S HEADS OF
UNSCRUPULOUS CUT-THROATS
↔ † 123456789 † †

MISCELLANEOUS.

8 A, 16 a.

THREE-LINE NONPAREIL CIRROUS. (T)

\$4.10

EVIDENCES OF EVOLUTION
Ring-Tailed Roman Design Attracted Attention 12

6 A, 12 a.

TWO-LINE PICA CIRROUS.

\$4.95

REVOLUTIONISTS
Justice Dispensed to all Applicants 34

4 A, 8 a.

THREE-LINE PICA CIRROUS.

\$6.10

INTERSPERSION
Of Grotesque and Elegant 5

12 A.

GREAT PRIMER ACADIAN No. 4. (T)

\$2.50

ROUND THE MARGIN OF THE WASTE

10 A.

DOUBLE SMALL PICA ACADIAN No. 4.

\$2.85

GLEANED BY SKILLFUL BOYS

8 A.

DOUBLE PICA ACADIAN No. 4.

\$3.10

LAMP, GAS AND TORCH

10 A.

THREE-LINE NONPAREIL IDEAL. (T)

\$2.85

WITH FRUITS AND FOLIAGE

7 A.

TWO-LINE PICA IDEAL.

\$3.00

BLOOMING BEAUTIFUL

MISCELLANEOUS.

PICA CHAUCER. (J) 12 A, 32 a. \$4.70

Impressive and Thoughtful
1234567890

THREE-LINE NONP. CHAUCER. 8 A, 20 a. \$5.55

Notice to our Patrons
12345678

TWO-LINE PICA CHAUCER. 6 A, 14 a. \$6.10

Antique Design
12345

DOUBLE PICA ALPINE. (T) 6 A, 12 a. \$4.35

DRINKERS
Touching Incident 3

THREE-LINE PICA ALPINE. 4 A, 8 a. \$5.80

RATION
Memories 82

LONG PRIMER MINSTER.
12 A, 32 a. Price, \$3.25.

LONGBOW DEBATERS
Political Candidate New's Gossipers

PICA MINSTER. (J)
10 A, 27 a. Price, \$3.70.

EGYPTIAN MAIDENS
Fancy Ethiopian Cheek Polish

GREAT PRIMER MINSTER.
8 A, 20 a. Price, \$4.60.

PARIS GREEN
Reputations Venerated

TWO-LINE PICA MINSTER.
6 A, 14 a. Price, \$5.75.

CHINESE
Century Pottery

Quads and Spaces extra.

LONG PRIMER TENDRIL.
12 A, 32 a. Price, \$3.15.

RECUPERATIVE EXPERIENCE
Patented Design in Peach Dumpling

PICA TENDRIL. (J)
10 A, 27 a. Price, \$5.75.

CHICKENSALAD LUNCH
Circumvallatory Wanderings

GREAT PRIMER TENDRIL.
8 A, 20 a. Price, \$4.60.

LEECH BLEEDING
Pugilistical Homicide

TWO-LINE PICA TENDRIL.
6 A, 14 a. Price, \$5.60.

DICTIONARY
Non Phrenology

PICA TEMPLAR. (R) 12 A, 18 a. \$3.00

TEMPERATE MUSKETEER
→ Boston City Guards ←

GT. PRIMER TEMPLAR. 9 A, 13 a. \$3.25

PREMIUM OFFERED
→ Worlds Exercises ←

DBL. SMALL PICA TEMPLAR. 7 A, 10 a. \$3.50

STEAM BOILER
→ Green Corn ←

DBL. ENGLISH TEMPLAR. 5 A, 7 a. \$4.00

AMERICANS
Historically

DBL. PARAGON TEMPLAR. 3 A, 5 a. \$5.00

COMICAL
Hilarities

MISCELLANEOUS.

BREVIER GLYPHTIC. (J)
22 A. Price, \$2.10.
*SADDLEHEAD'S * BEST * EDITIONS *

LONG PRIMER GLYPHTIC.
20 A. Price, \$2.10.
*SCULPTURED + MONOLITHS *

PICA GLYPHTIC.
18 A. Price, \$2.55.
*CERAMIC * RESEARCH *

GREAT PRIMER GLYPHTIC.
14 A. Price, \$2.95.
*FAN * DECORATING *

TWO-LINE PICA GLYPHTIC.
10 A. Price, \$3.70.
*WINE * LIST *

PICA COLONIAL. (D) 20 A. \$1.65
*PISTOL * SOLICITED * 359 *

GREAT PRIMER COLONIAL. 14 A. \$1.80
*PATRONIZERS * 79 *

TWO-LINE SMALL PICA COLONIAL. 10 A. \$2.00
*MORNING * 46 *

LONG PRIMER CAMPANILE.
16 A, 24 a. Price, \$2.25.
*MONTHLY COLLECTION OF DAINTIES *
Applicants + Enlightened + on + Questions + of + Law

PICA CAMPANILE. (J)
14 A, 20 a. Price, \$2.50.
*CRACKSMAN & LIGHTFINGER *
*Transactions * Strictly * Confidential *

GREAT PRIMER CAMPANILE.
10 A, 14 a. Price, \$2.90.
*OMNIBUS INDICATOR *
Coaches * through * to * Gintown

TWO-LINE PICA CAMPANILE.
7 A, 10 a. Price, \$3.65.
*ROAST * BEEF *
*Healthy * and * Good *

TWO-LINE GREAT PRIMER CAMPANILE.
4 A, 6 a. Price, \$4.55.
*ROVING *
*Highlanders *

Quads and Spaces extra.

TWO-LINE NONPAREIL MOXON. (D) 16 A. \$1.55

*SCHOOL * SYSTEM * 5 *

TWO-LINE MINION MOXON. 14 A. \$1.60

*PATRONAGE * 78 *

TWO-LINE LONG PRIMER MOXON. 10 A. \$1.90

*PARADISE * 8 *

TWO-LINE PICA MOXON. 6 A. \$2.00

*EXHIBIT *

TWO-LINE BREVIER ÆSTHETIC. 8 A, 12 A. \$3.30

*PERFORMING *
*MARK * DRAWS * 35 *

GRAND * PARKS

TWO-LINE LONG PRIMER ÆSTHETIC.
8 A, 10 A. \$3.90

*SPARKING *
*TIN * MERCHANT * 5

*MUSTANG *

TWO-LINE PICA ÆSTHETIC. 6 A, 8 A. \$4.70

*RANTER *
*NEW * METALIC

*PORT * 25 *

TWO-LINE ENGLISH ÆSTHETIC. 5 A, 7 A. \$4.90

*DUCKS *
*BLACK * RATS
*BOAR * 6 *

←KARNAC→

6 A, 12 a.

GREAT PRIMER KARNAC. (D)

\$3 40

→Madison Commercial Bank→
Annual Election of Principal Officers.
→Shares 58 Dividends→

5 A, 10 a.

DBL. SMALL PICA KARNAC.

\$3 75

→Christmas Festivities→
Thanksgiving 1885 Entertainment
→Grand Orchestra→

4 A, 8 a.

DBL. ENGLISH KARNAC.

\$4 90

→Foreign Imports→
→Sparkling \$43 Diamonds→
→Choice Jewelry→

3 A, 5 a.

DBL. GREAT PRIMER KARNAC.

\$4 90

→Horn & Grabb→
Wholesale Merchants.
→Richland 2→

MOTHER HUBBARD.

14 A.

PICA MOTHER HUBBARD. (D)

\$2 15

ARTISTIC AMERICAN PRINTER
SPECIAL DESIGNS 23 FINE ENGRAVINGS
ELEGANT SPECIMENS

10 A.

GREAT PRIMER MOTHER HUBBARD.

\$2 60

NATIONAL GUARDS
EXTRAORDINARY ILLUMINATION
PYROTECNICS 64

6 A.

TWO-LINE PICA MOTHER HUBBARD.

\$3 20

OPERAS 579
REFINED SINGERS

4 A.

TWO-LINE GREAT PRIMER MOTHER HUBBARD.

\$3 90

TRADE 8
MERCHANTS

3 A.

CANON MOTHER HUBBARD.

\$4 90

HOD 5
GRANDEUR

MISCELLANEOUS.

LONG PRIMER OLD STYLE CIRCULAR. (C) 15 A, 42 a. \$2.50

IMPORTANT NEWS
Gentle Mammals in Slumber 23

PICA OLD STYLE CIRCULAR. 12 A, 32 a. \$2.35
GRAND IMPROVEMENT
Standard Printing Houses 12

GT. PRIMER OLD STYLE CIRCULAR. 12 A, 32 a. \$3.50

Imported Instruments
Gold, Silver String 12

TWO-LINE ENGLISH CRITIC. (M) 8 A. \$5.30

THE BANK

LONG PRIMER OCCIDENT. (B) 20 A. \$1.65
FINER GREEN GRASS GROWS 38

PICA OCCIDENT. 15 A. \$1.75
NEWEST IN HATS & CAPS 32

GREAT PRIMER OCCIDENT. 10 A. \$2.00
6 DEMAND ONIONS 8

DOUBLE PICA OCCIDENT. 8 A. \$2.25
8 HONEST KIND

PICA OCCIDENT No. 2. (B) 15 A, 15 a. \$3.20
26 THE DENT & BURN LAD 26

GT. PRIMER OCCIDENT No. 2. 10 A, 10 a. \$3.25
3 SELL MEG & SHE TAR 3

DOUBLE PICA OCCIDENT No. 2. 8 A, 8 a. \$3.75
8 BE & CO BRAN 5

Quads and Spaces extra.

BREVIER LATIN ITALIC. (C) 20 A, 52 a. \$2.20
PROFESSOR STILLUM'S DREAM DROPS
Warrented to give Lasting Sleep to you 12

LONG PRIMER LATIN ITALIC. 20 A, 52 a. \$2.85
TRAVELERS STUDY INTEREST
Now is the time to buy your Ticket 15

PICA LATIN ITALIC. 15 A, 42 a. \$2.55
THE SHORTEST ROUTE TO
Swamp street right willing 16

GT. PRIMER LATIN ITALIC. 10 A, 27 a. \$3.30
SUPERIOR STOCK OF
Coats, Pants, Vests 16

LG. PRIMER OCCIDENT SHADED. (B) 20 A. \$1.95
MEMPHIS TO ROCHESTER 6

PICA OCCIDENT SHADED. 15 A. \$2.00
NOVEMBER TO AUGUST 3

GREAT PRIMER OCCIDENT SHADED. 10 A. \$2.25
BEND THE STEEL 6

DOUBLE PICA OCCIDENT SHADED. 8 A. \$2.50
REND THEM 2

PICA OCCIDENT SHADED No. 2. 15 A, 15 a. \$3.30
6 WINE & ALE HERE 6

GT. PRIM. OCCID. SHAD. No. 2. 10 A, 10 a. \$3.50
5 HAT & RAT SEC 3

DBL. PICA OCCID. SHAD. No. 2. 8 A, 8 a. \$4.00
3 DOG & BEN 8

142

Cincinnati Type Foundry, 201 Vine St.

MISCELLANEOUS.

- 10 A, 15 a. TWO-LINE NONPAREIL (12 POINTS) CHARTER. (B) \$3.05
LAUGHING COQUETTISH MAIDEN
Twenty Eight Hundred Thousand People 24
- 5 A, 12 a. THREE-LINE NONPAREIL (18 POINTS) CHARTER. \$4.60
KENTUCKY FARMS
Michigan and Lake Superior 56
- 6 A, 10 a. FOUR-LINE NONPAREIL (24 POINTS) CHARTER. \$5.40
CIRCULARS
The Charter Series 34
- 10 A, 20 a. PICA OCTAGON. (M) \$4.00
PANORAMA of the AMAZON
- 8 A, 16 a. GREAT PRIMER OCTAGON. \$6.50
RESUME and SHOP
- 6 A, 12 a. DOUBLE PICA OCTAGON. \$6.80
BON AND Minse Co.
- 10 A, 20 a. PICA LANDSEER. (B) \$3.90
«WESTERN CONTINENT»
Fire Marine & General Insurance Agents 45
- 6 A, 12 a. GREAT PRIMER LANDSEER. \$4.40
«SNOW STORM»
3 New Dining Parlor & Buffet
- 5 A, 8 a. DOUBLE PICA LANDSEER. \$5.60
«BUSINESS»
Thursday Evenings 5

MISCELLANEOUS.

LONG PRIMER OLD STYLE SHADED No. 2. (F)
12 A, 18 a. \$3.00

HOME BANK 84
Insurance Companies

PICA OLD STYLE SHADED No. 2. 8 A, 15 a. \$3.35

OLD SONG 85
Music Hath Charms

GT. PRIMER OLD STYLE SHADED No. 2.
6 A, 10 a. \$3.85

COMING 86
Election Times

TWO-LINE PICA OLD STYLE SHADED No. 2.
5 A, 8 a. \$5.00

DEPOT 7
Fast Trains

NONPAREIL (6 POINTS) ACME. 14 A, 20 a. \$2.40
(B)

BOARDING SCHOOL
Lip Curling and Head Tossing 576

BREVIER (8 POINTS) ACME. 12 A, 18 a. \$2.70

PACKET LINE
The Atlantic and Pacific 25

LG. PRIMER (10 POINTS) ACME. 10 A, 15 a. \$2.60

ROAST BEEF
Is Healthy and Good 45

2-LINE NONP. (12 POINTS) ACME. 8 A, 12 a. \$2.90

BENEATH
Diamond and Green 32

3-LINE NONP. (18 POINTS) ACME. 6 A, 10 a. \$3.90

JANUARY
Eighty Four 8

Quads and Spacers extra.

PICA OLD STYLE SHADED. (F) 18 A, 24 a. \$6.60

Commission House.

GT. PRIM. OLD STYLE SHADED. 15 A, 18 a. \$7.25

Great Eastern 8

DBL. SMALL PICA OLD STYLE SHADED.
12 A, 16 a. \$7.50

Good Time 7

DBL. ENGLISH OLD STYLE SHADED.
10 A, 12 a. \$8.50

Command 6

NONPAREIL CANTONIAN. (J) 18 A, 20 a. \$2.50

MYSTIFIED CHARACTERS
Wonderful Progressive Changes 123456

BREVIER CANTONIAN. 14 A, 18 a. \$2.90

CHANGEABLE SEASONS
Winter and Summer Sport 567

LONG PRIMER CANTONIAN. 12 A, 16 a. \$3.00

ABLE DEBATERS
Senatorial Gladiators 1234

PICA CANTONIAN. 10 A, 14 a. \$3.55

VERNAL SPRINGS
25 Delighted Visitors

GREAT PRIMER CANTONIAN. 7 A, 10 a. \$4.00

ARTISTIC
Sporting Men 5

DBL. PICA CANTONIAN. 5 A, 7 a. \$5.10

FAIRIES
5 Bad Boys

DBL. GREAT PRIMER CANTONIAN. 4 A, 6 a. \$7.40

TIMES
Freaks 8

MISCELLANEOUS.

PICA STERLING. (F) 12 A, 8 A. \$3.00
STERLING CHARACTER

3-LINE NONPAREIL STERLING. 6 A, 8 A. \$4.00
FINE STERLING

2-LINE PICA STERLING. 6 A, 8 A. \$4.00
NEW RING 8

3-LINE PICA STERLING. 4 A, 4 A. \$6.75.
SET ME 2

BREVIER COND. CLOISTER SHADED. (J) 30 A. \$2.40
MYSTERIES OF MECHANICAL POWER

Lg. PRIMER COND. CLOISTER SHADED. 25 A. \$2.40
NATIONAL TEST OF MANNERS

PICA COND. CLOISTER SHADED. 18 A. \$2.60
GEOMETRY DESTROYED

Gt. PRIMER COND. CLOISTER SHADED. 12 A. \$2.75
WINTER 56 WIND

DBL. SM. PICA CON. CLOISTER SHADED. 10 A. \$3.05
FAIR 76 GEMS

DBL. ENGLISH CON. CLOISTER SHADED. 7 A. \$3.80
41 SPRINGS

DBL. GT. PRIM. CON. CLOISTER SHADED. 5 A. \$4.30
TRIPS 34

DBL. PARA. COND. CLOISTER SHADED. 5 A. \$5.00
78 CARS

Gt. PRIMER HORIZONTAL SHADE. 8 A, 12 a. \$3.50
Horizontal Reduction 82

2-LINE PICA HORIZONTAL SHADE. 6 A, 8 a. \$4.50
Beautiful Design 3

2-LINE GT. PRIMER HORIZ. SHADE. 4 A, 6 a. \$5.00
Americans 4

4-LINE PICA HORIZONTAL SHADE. 3 A, 4 a. \$6.50
Master 5

BREVIER CLOISTER SHADED. (J) 30 A. \$2.80
THESPIAN ENTERTAINMENTS

LONG PRIMER CLOISTER SHADED. 25 A. \$3.10
DELIGHTED HOUSEHOLD

PICA CLOISTER SHADED. 18 A. \$3.20
234 COMICAL JOKES

GREAT PRIMER CLOISTER SHADED. 12 A. \$3.30
WALKERS 890

DBL. SM. PICA CLOISTER SHADED. 10 A. \$4.00
24 TRAMPS

DBL. ENGLISH CLOISTER SHADED. 7 A. \$4.45
GAME 79

DBL. GT. PRIMER CLOISTER SHADED. 5 A. \$4.75
8 GUMS

DBL. PARAGON CLOISTER SHADED. 5 A. \$6.10
MEN 5

ECLIPSE.

10 A, 15 a.

PICA ECLIPSE. (B)

\$5.20

HUDSONS ~~AND~~ BROWNELLS
76 Birds go Singing 67

6 A, 10 a.

GREAT PRIMER ECLIPSE.

\$6.00

DENYER ~~AND~~ OMAHA
Hard Storms 78

5 A, 6 a.

DBL. PICA ECLIPSE.

\$7.00

WET ~~AND~~ COLD
Eastern 3

ECLIPSE SHADED.

10 A, 15 a.

PICA ECLIPSE SHADED No. 2. (B)

\$5.50

HUDSONS ~~AND~~ BROWNELLS
76 Birds go Singing 67

8 A, 10 a.

GREAT PRIMER ECLIPSE SHADED No. 2.

\$6.30

DENYER ~~AND~~ OMAHA
Hard Storms 78

5 A, 6 a.

DBL. PICA ECLIPSE SHADED No. 2.

\$7.25

WET ~~AND~~ COLD
Eastern 3

ST. LOUIS SERIES.

8 A, 14 a.

THREE-LINE NONPAREIL ST. LOUIS. (SL.)

\$3 25

A WONDERFUL COMBINATION BALLET
123 Fastily Condensed and Beautifully Shaded 564

6 A, 10 a.

TWO-LINE PICA ST. LOUIS.

\$4 00

TYPOGRAPHIC ATTRACTION
Knowledge and Power are Friends 78

5 A, 6 a.

THREE-LINE PICA ST. LOUIS.

\$5 00

MISCHIEVOUS FAIRY
Put a Girdle Round About 13

5 A, 6 a.

FOUR-LINE PICA ST. LOUIS.

\$7 50

RELIEFS OF WOR
Base Ball and Corns 9

4 A, 5 a.

SIX-LINE PICA ST. LOUIS.

\$12 50

LATE RICE
American of '85

MISCELLANEOUS.

2-LINE NONP. (12 POINTS) CALUMET. (B) 12 A. \$2.10

GREAT BRITAIN 15

3-LINE NONP. (18 POINTS) CALUMET. 8 A. \$2.50

COMPANY 57

4-LINE NONP. (24 POINTS) CALUMET. 6 A. \$3.20

ROUTE 3

GT. PRIMER MALTESE OPEN. (B) 6 A, 12 a. \$3.75

Maple Shade Vale

DBL. SM. PICA MALTESE OPEN. 5 A, 10 a. \$4.25

Silent Villager

DBL. ENGLISH MALTESE OPEN. 4 A, 8 a. \$4.75

Fair Haven

2-LINE NONP. (12 POINTS) COREAN. (B) 12 A. \$2.40

GREAT BRITAIN 4

3-LINE NONP. (18 POINTS) COREAN. 8 A. \$2.65

COMPANY 4E

4-LINE NONP. (24 POINTS) COREAN. 6 A. \$4.00

ROUTE 3

PICA GRAVERS SHADE. (F) 12 A. \$3.50

THE NATION. 8

GT. PRIMER GRAVERS SHADE. 10 A. \$5.00

FLORIDA 7

TWO-LINE PICA GRAVERS SHADE. 8 A. \$6.00

CAMP 2

TWO-L. GT. PRIM. GRAVERS SHADE. 6 A. \$8.00

LONG

PICA LATTICE. (B) 12 A. \$2.35

+FOURTH OF JULY 4+

GREAT PRIMER LATTICE. 10 A. \$3.00

PANSY CLUBS 33

DBL. PICA LATTICE. 8 A. \$3.60

MICHIGAN 57

GREAT PRIMER MALTESE. (B) 6 A, 12 a. \$3.75

Rushed in Repose

DBL. SMALL PICA MALTESE. 5 A, 10 a. \$4.25

Indian Ravage

DBL. ENGLISH MALTESE. 4 A, 8 a. \$4.75

Melon Laid

PICA STEEL PLATE. (B) 12 A. \$3.20

THA BOOM 2

GREAT PRIMER STEEL PLATE. 10 A. \$4.00

CRANKS 8

TWO-LINE PICA STEEL PLATE. 8 A. \$5.10

MOIST 3

PICA RUSKIN. (J) 12 A. \$1.75

SPARKLING DIAMOND

GREAT PRIMER RUSKIN. 10 A. \$2.65

NATIONALITIES

DOUBLE PICA RUSKIN. 7 A. \$3.25

IMPIDENCE

DBL. GREAT PRIMER RUSKIN. 5 A. \$4.05

WISDOM

MISCELLANEOUS.

PICA LAUREL. (B) 15 A. \$2.00

CHICAGO † AND † TOLEDO

GREAT PRIMER LAUREL. 10 A, 10 A. \$3.50

WINDS † MOUNT † BLOW

DBL. PICA LAUREL. 8 A, 8 A. \$4.50

SIX † AND † NINE

DBL. GREAT PRIMER LAUREL. 6 A, 6 A. \$5.00

SHINE † BRIGHT

DBL. PARAGON LAUREL. 5 A, 5 A. \$5.60

TENTS
HAND † HOME

PICA STENCIL. (J) 10 A, 16 a. \$3.30

MANLY CONTESTS
15 Snow-Shoe Trials

THREE-LINE NONP. STENCIL. 7 A, 10 a. \$4.20

SNUG HOMES
Militia 2 Drill

TWO-LINE PICA STENCIL. 6 A, 8 a. \$5.20

JUDICIAL
45 Process

THREE-LINE PICA STENCIL. 4 A, 6 a. \$7.00

CHAPS
8 Cents

Quads and Spaces extra.

LONG PRIMER COPPERPLATE.
18 A. Price, \$2.90.

ELECTION LOBBIES

PICA COPPERPLATE. (J)
16 A. Price, \$3.20.

BALMY BREEZE

GREAT PRIMER COPPERPLATE.
12 A. Price, \$3.80.

DOUGHNUTS

TWO-LINE PICA COPPERPLATE.
8 A. Price, \$4.90.

FEELING

PICA AQUATINT.
14 A, 20 a. Price, \$3.70.

EXTRA ANNOUNCEMENT
Treatments for the Million

GREAT PRIMER AQUATINT. (J)
10 A, 14 a. Price, \$4.25.

RUBBER COATING
Irremovable Varnish

TWO-LINE PICA AQUATINT.
7 A, 10 a. Price, \$5.55.

INSURANCE
Double Secure

TWO-LINE GREAT PRIMER AQUATINT.
5 A, 7 a. Price, \$7.20.

FROZEN
Clear Ices

THREE-LINE NONP. PICTORIAL. (J) 12 A. \$2.30

12 EARLY BIRDS 34

TWO-LINE PICA PICTORIAL. 8 A. \$2.75

LUCKY 567 MEN

THREE-LINE PICA PICTORIAL. 6 A. \$3.90

13 GARDEN

MISCELLANEOUS.

10 A., 20 a.

PICA VICTOR. (B)

\$4.05

«HIGHWAY CLEANERS»

Ten Organ Grinders & Other Musicians 45

6 A., 12 a.

GREAT PRIMER VICTOR.

\$4.65

«NEWSPAPERS»

3 Railroad & Standard Time

5 A., 8 a.

DOUBLE PICA VICTOR.

\$5.55

«SERVANT»

Banking Company 4

LONG PRIMER CLEFT GOTHIC. (B) 12 A. \$1.40

DAILY NEWS

COUNTRY PAPER*

* 2735 *

PICA CLEFT GOTHIC. 10 A. \$1.50

RAILROAD

THE TRAINS

* 378 *

8 A.

GREAT PRIMER CLEFT GOTHIC.

\$2.00

CIGAR STORES

PASSENGER AGENTS

TWO-LINE NONPAREIL FLORIST. (B) 10 A. \$1.50

SHOVELS 4

JAPANESE OPERA

THREE-LINE NONPAREIL FLORIST. 8 A. \$1.75

BUILD 3

FINE CANDY

6 A.

FOUR-LINE NONPAREIL FLORIST.

\$2.25

AGENTS 4

ELEGANT FLOWERS

Quads and Spaces extra.

150

Cincinnati Type Foundry, 201 Vine St.

ARBORET NO. 2.

10 A.

PICA ARBORET No. 2. (J)

\$3.80



8 A.

THREE-LINE NONPAREIL ARBORET No. 2.

\$4.90

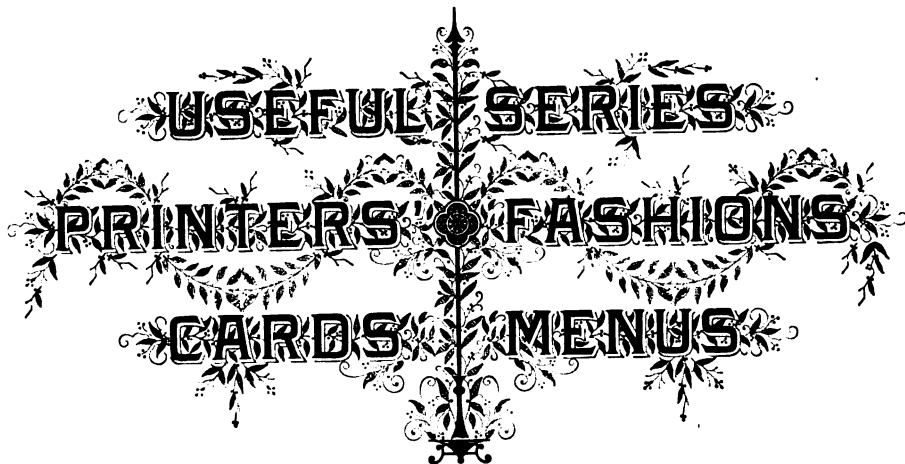

6 A.

TWO-LINE PICA ARBORET No. 2.

\$5.50

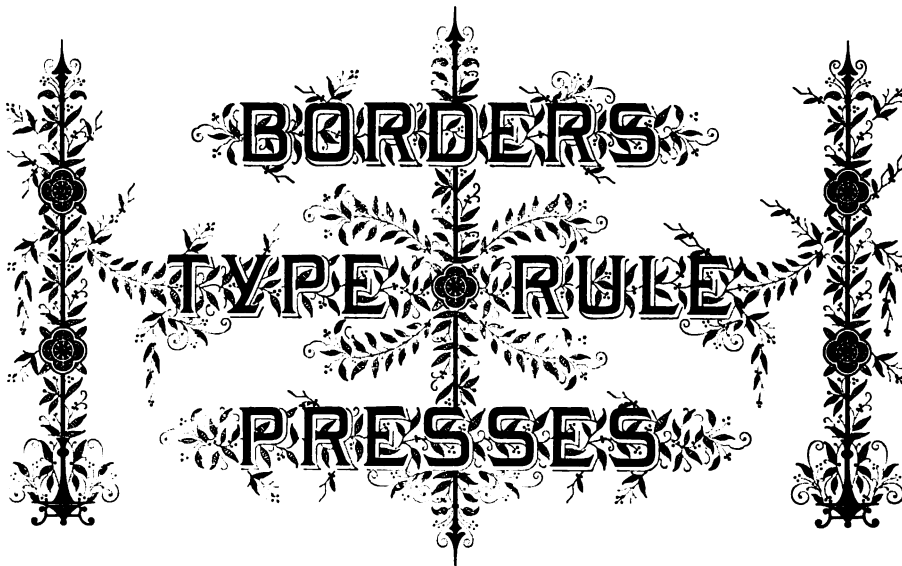

Quads and Spaces extra.

151

Cincinnati Type Foundry, 201 Vine St.

MISCELLANEOUS.

10 A. THREE-LINE NONPAREIL REMBRANDT. (T) \$2.00
TRAVELS OF CELEBRATED EUROPEANS

7 A. TWO-LINE PICA REMBRANDT. \$2.15
OHIO FORESTERS CONVENTIONS

5 A. THREE-LINE PICA REMBRANDT. \$2.85
SCULPTORS & PAINTERS

6 A. 12 a. TWO-LINE PICA SIGNET SHADE. (T) \$5.00
BUCOLIC BEAUTIES
29 Artists Enjoy Odd Conceit 78

4 A. 8 a. THREE-LINE PICA SIGNET SHADE. \$7.50
MAGNIFICENT
5 Delectable Pleasing 4

10 A. THREE-LINE NONPAREIL SOUVENIR. (F) \$3.75
MOONLIGHT PROMENADE 5

8 A. TWO-LINE PICA SOUVENIR. \$4.25
EDITORIAL POINT 6

5 A. THREE-LINE PICA SOUVENIR. \$6.00
FINE GOODS 16

MISCELLANEOUS.

3-LINE NONP. CRAYON. (J) 5 A, 12 a. \$4.05

2-LINE PICA CRAYON. 5 A, 10 a. \$5.15

Mexican *Ancient*
National Banks *River & Boat*

3 A, 5 a.

THREE-LINE PICA CRAYON.

\$6.30

Beechtown Foresters

7 A, 16 a.

THREE-LINE NONPAREIL MEDALLIC. (J)

\$3.00

Colleges for Technical Education
Thorough Apprentices *Competent Journeymen*
1234567890

6 A, 14 a.

TWO-LINE PICA MEDALLIC.

\$1.95.

Funning Epistles from Unpaid Mechanics
1234567890

4 A, 8 a.

THREE-LINE PICA MEDALLIC.

\$4.00

Presidents and Secretaries 789

PICA TINTED. (J) 12 A. \$2.15

PLEASANT GROVES

THREE-LINE NONPAREIL TINTED. 8 A. \$2.65

ENTHUSIASM

TWO-LINE PICA TINTED. 7 A. \$3.30

RAMBLING

FIVE-LINE NONPAREIL TINTED. 5 A. \$3.85

QUINGES

4 A.

THREE-LINE PICA TINTED.

\$4.00

WATERWORKS

Quads and Spaces extra.

153

Cincinnati Type Foundry, 201 Vine St.

MISCELLANEOUS.

5 A, 14 a. THREE-LINE NONPAREIL LABELLE. (P) \$3.85

CINCINNATI FOUNDRY
Showing Latest Styles of Specimens

5 A, 10 a. FOUR-LINE NONPAREIL LABELLE. \$5.00

SUMMER EXCURSION
Rowing Sailing and Bathing

4 A, 7 a. SIX-LINE NONPAREIL LABELLE. \$7.50

PIED SORTS
Base Ball Tossers

10 A. PICA AURORAL. (T) \$2.15

UNITED STATES BONDS
NATIONAL GREENBACK PARTY. SIZE

8 A. THREE-LINE NONPAREIL AURORAL. \$3.00

GRAND CONCERT
AARON MILITARY BAND

6 A. TWO-LINE PICA AURORAL. \$3.80

STOCKHOLDER
COMMERCIAL BANK

4 A. THREE-LINE PICA AURORAL. \$5.75

HUNTER
GOLD MINE 13

STEEL PLATE GOTHIC.

12 A.

PICA STEEL-PLATE GOTHIC. (J)

\$2.15

RELIABLE INDICATIONS
ELECTRIC LIGHT SOLAR EXHIBITS
1234567890

8 A.

THREE-LINE NONPAREIL STEEL-PLATE GOTHIC.

\$2.45

EARLY MORNING DISTURBANCE
1234567890

7 A.

TWO-LINE PICA STEEL-PLATE GOTHIC.

\$3.00

45 NORTHERN SCENES

4 A.

THREE-LINE PICA STEEL-PLATE GOTHIC.

\$4.10

CARPET BAGS 88

UMBRA.

8 A.

THREE-LINE NONPAREIL (18 POINTS) UMBRA. (B)

\$2.55

PRINTERS' FAVORITE BOOK
23 CINCINNATI OHIO 45

6 A.

FOUR-LINE NONPAREIL (24 POINTS) UMBRA.

\$3.25

GERMAN COMPANIES
4 SALT LAKES 8

4 A.

SIX-LINE NONPAREIL (36 POINTS) UMBRA.

\$4.95

CORAL ROCKS
7 PAINTS 6

STYLUS.

3-LINE EXCELSIOR STYLUS. (J) 12 A, 32 a. \$2.70

Late Important Despatches from Haiti Creek

1 2 3 4 5 6 7 8 9 0

TWO-LINE PICA STYLUS. 6 A, 14 a. \$5.60

751 Trade Names

PICA STYLUS. 12 A, 32 a. \$3.90

Jad-Hearted Excursionist at Sea

1 2 3 4 5 6 7 8 9 0

THREE-LINE NONP. STYLUS. 8 A, 20 a. \$5.05

Complimentary Notices

GROLIER.

PICA GROLIER. (J) 4 A, 8 A, 40 a. \$5.60

Extra Lower Case, \$2.10

Declaration of Independence

Disseminating the Constitution

Birthplace of Freedom

3-LINE NONP. GROLIER. 3 A, 6 A, 30 a. \$6.90

Extra Lower Case, \$2.55

Presidential Receptions

Meeting of Governors

3 A, 4 A, 20 a. \$7.50

TWO-LINE PICA GROLIER.

Extra Lower Case, \$2.30

Association for Encouragement of Industry

PENCRAFT.

PICA PENCRAFT. (J) 4 A, 8 A, 32 a. \$5.25

Extra Lower Case, \$2.05

Sketch from Memory

History of our Neighbours

3-LINE NONP. PENCRAFT No. 2. 3 A, 4 A, 20 a. \$6.80

Extra Lower Case, \$2.00

Deceptive Science

Penmanship Lessons

THREE-LINE NONPAREIL PENCRAFT, WITH THREE-LINE PICA INITIALS.
4 A, 12 a, 3 A Initials.

\$6.80

Handsome Card Ornaments

Elegant Display of Printing Machinery

MISCELLANEOUS.

6 A, 14 a.

THREE-LINE NONPAREIL LADY TEXT. (J)

\$3.90

GRAND EXHIBIT

Opening of Races

Christmas Holiday

5 A, 10 a.

TWO-LINE PICA LADY TEXT.

\$4.50

INDIA SHAWL

Bridal Presents

Costly Treasure

4 A, 8 a.

TWO-LINE PICA GEM. (F)

\$4 00

Boating Clubs, \$4825

Moonlight Excursions on Hudson River.

3 A, 8 a.

THREE-LINE PICA GEM.

\$5 50

Gentlemen's Furnishing Goods

8 A, 20 a.

PICA ANGULAR TEXT. (J)

\$2.85

Antiquated, Journalistic, Phrases.

Prophetic Inscriptions and Quaint Monumental Designs

6 A, 14 a.

THREE-LINE NONPAREIL ANGULAR TEXT.

\$3.25

National Banking Institution

Commercial Letters

Securities Negotiated

5 A, 10 a.

THREE-LINE PICA ANGULAR TEXT.

\$3.70

International

Electrical 1234567890 Exhibitions

MISCELLANEOUS.

TWO-LINE PICA TITLE TEXT OPEN, No. 3.
6 A, 14 a. Price, \$4.85.

Magnetic Reflections

TWO-LINE ENGLISH TITLE TEXT OPEN, No. 3.
6 A, 14 a. Price, \$5.75. (J)

Political Explorations

TWO-LINE GT. PRIM. TITLE TEXT OPEN, No. 3.
5 A, 10 a. Price, \$5.90.

Marriage Bureau

DOUBLE PARAGON TITLE TEXT OPEN, No. 3.
4 A, 7 a. Price, \$5.30.

Original States

GREAT PRIMER TITLE TEXT OPEN.
8 A, 20 a. Price, \$3.50.

Depositors of all Nations and Colors

TWO-LINE SMALL PICA TITLE TEXT OPEN.
8 A, 20 a. Price, \$4.30.

Childhood's Youthful Minds

2-LINE SM. PICA TITLE TEXT OPEN No. 2.
8 A, 20 a. Price, \$4.20.

Strains of Cheerful Harmony

TWO-LINE PICA TITLE TEXT OPEN.
6 A, 14 a. Price, \$4.85.

Wedding Celebration

TWO-LINE ENGLISH TITLE TEXT OPEN.
6 A, 14 a. Price, \$5.75.

Perfumes of the Rose

TWO-LINE GREAT PRIMER TITLE TEXT OPEN.
5 A, 10 a. Price, \$5.80.

Artistic Jewellers

DOUBLE PARAGON TITLE TEXT OPEN.
4 A, 7 a. Price, \$5.30.

Moving Crops

FOUR-LINE PICA TITLE TEXT OPEN.
3 A, 5 a. Price, \$6.85.

Santa Claus

Quads and Spaces extra.

3-LINE NONP. GRAPHIC TEXT. (J) 6 A, 14 a. \$3.60

Unique 1234 Specimens

TWO-LINE PICA GRAPHIC TEXT. 5 A, 10 a. \$3.95

Rural 567 Scenes

4-LINE PICA GRAPHIC TEXT. 3 A, 5 a. \$4.55

Boys and Girls

GT. PRIM. STEEL-PLATE TEXT. (B) 6 A, 14 a. \$3.75

Beautiful Willows 47

[DBL. PICA STEEL-PLATE TEXT. 5 A, 10 a. \$4.25

Flown Robins 2

DBL. ENGLISH STEEL-PLATE TEXT. 4 A, 8 a. \$4.75

New Walls 5

GREAT PRIMER MEZZOTYPE. (J) 5 A, 10 a. \$2.80

Wonderful Scenes

DOUBLE PICA MEZZOTYPE. 4 A, 8 a. \$4.15

Fairy Tales

DBL. GREAT PRIMER MEZZOTYPE. 3 A, 5 a. \$4.00

Beautiful

GT. PRIMER CHASED BLACK. (B) 8 A, 14 a. \$4.50

Something New 7

DBL. SM. PICA CHASED BLACK. 6 A, 12 a. \$5.00

Monogram. 7

DBL. ENGLISH CHASED BLACK. 5 A, 8 a. \$5.50

New York.

DBL. PARAGON CHASED BLACK. 4 A, 6 a. \$7.50

Bearer. 7

MISCELLANEOUS.

LG. PR. LIGHT MODEL BLACK. (F) 15 A, 36 a. \$4.50
Late Magazine Publications

PICA LIGHT MODEL BLACK. 12 A, 30 a. \$5.50
Cincinnati Type Foundry

GT. PRIM. LIGHT MODEL BLACK. 10 A, 20 a. \$5.00
Government Stamps

DBL. SMALL PICA LIGHT MODEL BLACK.
 8 A, 16 a. \$7.00
Choice Display

DBL. ENGLISH LIGHT MODEL BLACK.
 5 A, 12 a. \$7.50
Daily Mail

DBL. GREAT PRIMER LIGHT MODEL BLACK.
 5 A, 10 a. \$7.50
Fine Arts

GREAT PRIMER RIPPLE TEXT.
 8 A, 18 a. Price, \$3.95.
Mohammedan Domestic

TWO-LINE PICA RIPPLE TEXT. (J)
 6 A, 14 a. Price, \$5.15.
Omnibus Indicator

TWO-LINE GREAT PRIMER RIPPLE TEXT.
 5 A, 10 a. Price, \$6.95.
Evening Stars

PICA SLOPING BLACK.
 12 A, 32 a. Price, \$4.80.
Neptune Salt Manufacturing Co.

GREAT PRIMER SLOPING BLACK. (J)
 8 A, 20 a. Price, \$4.75.
Malice Towards None

TWO-LINE SMALL PICA SLOPING BLACK.
 8 A, 18 a. Price, \$6.00.
Superb Institutions

TWO-LINE ENGLISH SLOPING BLACK.
 5 A, 10 a. Price, \$6.00.
Evening Print

TWO-LINE GREAT PRIMER SLOPING BLACK.
 4 A, 7 a. Price, \$6.60.
Mementoes

Quads and Spaces extra.

PICA COPPER-PLATE TEXT. (F) 10 A, 20 a. \$4.00
Splendid New Outfits 8

GT. PRIM. COPPER-PLATE TEXT. 7 A, 12 a. \$4.65
Original Faces. 9

DBL. SM. PICA COP.-PLATE TEXT. 6 A, 10 a. \$4.75
Grand Army. 7

DBL. ENGLISH COP.-PLATE TEXT. 4 A, 8 a. \$5.50
Eloquence. 9

PICA MODEL BLACK SHADED. (F) 12 A, 30 a. \$5.50
Cincinnati Bankers. 67

GREAT PRIMER MODEL BLACK SHADED.
 8 A, 20 a. \$5.00
Hamburg Lines. 4

DBL. SMALL PICA MODEL BLACK SHADED.
 10 A, 16 a. \$7.00
New Faces. 7

TWO-LINE ENGLISH MODEL BLACK SHADED.
 5 A, 12 a. \$7.50
Homestead.

DBL. SM. PICA MEMORIAL. (R) 7 A, 10 a. \$3.50
SADDER SHOCKS
United States Militia

DBL. ENGLISH MEMORIAL. 5 A, 7 a. \$4.25
FIRST NIGHT
Americanism

DBL. PARAGON MEMORIAL. 3 A, 5 a. \$5.00
MEDIEVAL
Womankind

Boston Script.

9 A, 25 a.

GREAT PRIMER BOSTON SCRIPT. (R)

\$6.00

Unsurpassed in quality and color
We would call your attention to our Grand Fall Display
on Monday, November 27th, 1882.
Black Satins, Alpacas, Cachmeres & Brocades.

7 A, 20 a.

DOUBLE PICA BOSTON SCRIPT.

\$8.00

Mrs. Adams requests the pleasure
of Your Company on Friday Evening,
Wednesday, November 27th.

5 A, 15 a.

DOUBLE GREAT PRIMER BOSTON SCRIPT.

\$10.00

Commercial Job Printers
John Hinman Co.
Second National Bank

4 A, 10 a.

CANON BOSTON SCRIPT.

\$12.00

Herman Academy
Monograms 57

PAYSON AND STANDARD SCRIPTS.

GT. PRIMER PAYSON SCRIPT. (F) 15 lbs. \$15.00

French China Glassware
Foreign Articles \$125

DBL. PICA PAYSON SCRIPT. 15 lbs. \$13.50

United States 7
Government Bonds

DBL. GT. PRIMER PAYSON SCRIPT. 15 lbs. \$12.30

National Bank
Silver Dollar 2

DBL. GT. PRIMER PAYSON SCRIPT No. 2.
15 lbs. \$12.30

Engine Works
Department 3

16 lbs.

DOUBLE PARAGON PAYSON SCRIPT.

\$12.50

Noisy Crowd Welcoming 2

9 A, 25 a.

THREE-LINE NONPAREIL (18 POINTS) STANDARD SCRIPT. (B)

\$6.00

Obliging Printing and Stationery Company
Chicago Rock Island and Pacific Railroad in 1887

7 A, 20 a.

FOUR-LINE NONPAREIL (24 POINTS) STANDARD SCRIPT.

\$8.00

Young Ladies Fether Club
Hudson River Steamboat Companies 76

5 A, 15 a.

SIX-LINE NONPAREIL (36 POINTS) STANDARD SCRIPT.

\$10.00

Bond and Note Dealer
Saturday, October 24th, 1897

4 A, 10 a.

EIGHT-LINE NONPAREIL (48 POINTS) STANDARD SCRIPT.

\$12.00

Pay James E Dale
Seven Hundred 35

HEADING SCRIPTS.

DOUBLE PARAGON HEADING SCRIPT No. 1. (F) 5 A Caps, \$8.00; 12 a Lower Case, \$7.00.

Roman Sculptures
Orations of Demosthenes.

DOUBLE PARAGON HEADING SCRIPT No. 2. 5 A Caps, \$8.00; 12 a Lower Case, \$6.00.

Public Commissioners.
American Book Publishers.

DOUBLE PARAGON HEADING SCRIPT No. 3. 5 A Caps, \$8.00; 12 a Lower Case, \$5.00.

The State Treasurer
The Beautiful New Script

Complete Font, Caps and Lower Case Nos. 1, 2 and 3, \$25.00.

FIVE-LINE PICA HEADING SCRIPT No. 1. (F) 4 A Caps \$9.00; 8 a Lower Case, \$8.50.

Fire Insurance.

FIVE-LINE PICA HEADING SCRIPT No. 2. 4 A Cap, \$9.00; 8 a Lower Case, \$7.50.

Commercial Banking

FIVE-LINE PICA HEADING SCRIPT No. 3. 4 A Caps, \$9.00; 8 a Lower Case, \$7.00.

Produce Merchants

Complete Font, Caps and Lower Case Nos. 1, 2 and 3, \$30.00.

Quads and Spaces included.

162

Cincinnati Type Foundry, 201 Vine St.

SPENCERIAN SCRIPT.

9 A, 50 a. TWO-LINE BREVIER SPENCERIAN SCRIPT No. 2. (J) \$9.15

Initiation of Members and Cabalistic Observances

Wednesday Evening, September 27, 1896.

3 A. Ornamental Caps, separately, \$1.20.

9 A, 50 a. TWO-LINE SMALL PICA SPENCERIAN SCRIPT No. 2. \$12.40

Lessons in the Arts and Mysteries of Courtship

Methods for Becoming Fascinating

3 A. Ornamental Caps, separately, \$1.65.

8 A, 30 a. TWO-LINE ENGLISH SPENCERIAN SCRIPT No. 2. \$13.90

Distribution of Unexpended Greenbacks

Midnight Perambulators

3 A. Ornamental Caps, separately, \$2.15.

5 A, 25 a. DOUBLE PARAGON SPENCERIAN SCRIPT No. 2. \$17.95

Wednesday Evening, February 7.

2 A. Ornamental Caps, separately, \$2.80.

9 A, 50 a. TWO-LINE BREVIER SPENCERIAN SCRIPT. \$9.15

*This Intelligent Combination of Late Improvements
is presented for further appreciative consideration. Its*

9 A, 50 a. TWO-LINE SMALL PICA SPENCERIAN SCRIPT. \$13.65

*This Series of a New Style of Script,
which we call Spencerian, we present to the*

8 A, 30 a. TWO-LINE ENGLISH SPENCERIAN SCRIPT. \$14.40

Ladies' Amateurs and Correspondent,

5 A, 25 a. DOUBLE PARAGON SPENCERIAN SCRIPT. \$20.00

Philadelphia to Somewhere.

3 A, 9 a. FIVE-LINE PICA SPENCERIAN SCRIPT. \$17.60

Highway Department

MISCELLANEOUS SCRIPTS.

6 A, 16 a.	GREAT PRIMER LADIES' HAND SCRIPT. (M)	\$3.75
<i>Breathed by the Lips of Honor may Destroy some Noble Reputation.</i>		
4 A, 12 a.	DOUBLE PICA LADIES' HAND SCRIPT.	\$4.00.
<i>Have a Care of What you Say and More of what</i>		
3 A, 8 a.	DOUBLE COLUMBIAN LADIES' HAND SCRIPT.	\$4.50
<i>Fanciful notions Dispelled by Contrast</i>		
6 A, 16 a.	GREAT PRIMER LADIES' HAND SCRIPT No. 2.	\$3.75
<i>Perseverance has its own Reward in final Success amongst</i>		
4 A, 12 a.	DOUBLE PICA LADIES' HAND SCRIPT No. 2.	\$4.50
<i>Distance lends Enchantment, and Beautiful</i>		
3 A, 8 a.	DOUBLE COLUMBIAN LADIES' HAND SCRIPT No. 2.	\$4.75
<i>Trust always Home and Friends</i>		
7 A, 20 a.	FIVE-LINE NONPAREIL (30 POINTS) STEEL-PLATE SCRIPT No. 1.* (St.)	\$9.00.
Caps, \$4.50.		Lower Case, \$4.50.
<i>Madame Senat and Signor Neptune 7</i>		
7 A, 25 a.	FIVE-LINE NONPAREIL (30 POINTS) STEEL-PLATE SCRIPT No. 2.*	\$9.00
Caps, \$4.50.		Lower Case, \$4.50.
<i>Antique Conglomerate Universal Detractors 8</i>		
8 A, 32 a.	DOUBLE PICA CLEVELAND SCRIPT. (T)	\$8.50
<i>We here present for the approval 1739</i>		
6 A, 50 a.	PARAGON MODEL SCRIPT.* (F)	\$10.00
<i>Accident Insurance Modern Faces 75</i>		
16 pounds.	DOUBLE GREAT PRIMER MODEL SCRIPT.*	\$13.25
<i>New England Building Societies</i>		

Quads and Spaces extra, except *

164

Cincinnati Type Foundry, 201 Vine St.

MISCELLANEOUS SCRIPTS.

- 6 A, 40 a GREAT PRIMER MYRTLE SCRIPT. (B) \$5.00
Miss Beautiful Myrtle Script 18
Thursday Afternoon and Evening November the twenty third
- 5 A, 30 a DOUBLE PICA MYRTLE SCRIPT. \$6.00
Number 201 Vine Street
Office of the Cincinnati Type Foundry Ohio
- 7 A, 20 a DOUBLE PICA ARTISTIC SCRIPT. (B) \$7.00
Cincinnati Ohio November 23rd 1887
Have a care of what you say and more of what you do
- 8 A, 40 a, \$4.00 TWO-LINE NONPAREIL (12 POINTS) PRINCESS SCRIPT. (B) 16 A, 80 a, \$7.50
Received Thursday Afternoon June 29th 1887
Mahogany Black Walnut and Rosewood Drawing Room Furniture
- 6 A, 40 a, \$5.50 THREE-LINE NONPAREIL (18 POINTS) PRINCESS SCRIPT. 12 A, 80 a, \$10.00
German Medicines Drugs Perfumery 2543
Importers and Wholesale Dealers in English French and
- 5 A, 30 a, \$6.50 FOUR-LINE NONPAREIL (24 POINTS) PRINCESS SCRIPT. 10 A, 60 a, \$12.00
25 to 49 East Green Street
Stationary Steam Engine and Boiler Works
- 7 A, 20 a. DOUBLE PICA MAGNOLIA SCRIPT. (R) \$7.00
Banking Establishment of Madame Solmen
Sixteen Hundred Thousand Dollars
- 7 A, 20 a. DOUBLE PICA AUTOGRAPH SCRIPT. (R) \$8.00
Dodgeville Insurance Associations
Wallingford, Richardson & Co.

MISCELLANEOUS.

8 A, 32 a. DOUBLE SMALL PICA CARPENTER SCRIPT. (T) \$8.50

This delicate and beautiful Type properly printed will present an appearance of great grace. Jan. 1st, 1884.

8 A, 32 a. TWO-LINE ENGLISH CARPENTER SCRIPT. \$12.50

There are many handsome Script Types made, but none to surpass Carpenter for effective

10 A, 50 a. • GREAT PRIMER LAW-HAND. (F) \$10.00

*There is Poetry that is Beautiful, Impressive and Instructive, Elevat-
Sensational Literature \$123456*

8 A, 36 a. TWO-LINE PICA LAW-HAND. \$12.00

*In remote times the Me-
dium for Interchanging the
The Daily Press \$123456*

7 A, 20 a. FIVE-LINE NONPAREIL (30 POINTS) ROYAL SCRIPT No. 1. (SL.) \$9.00
Caps, \$4.50. Lower Case, \$4.50.

*46 Antimony St., Leadville.
Manufacture Artistic Typographers*

6 A, 18 a. FIVE-LINE NONPAREIL (30 POINTS) OLD STYLE SCRIPT. \$9.00
Caps, \$4.50. Lower Case, \$4.50.

*Menagerie 9852. Members.
Fine Antediluvian. Arkitecture*

Manuscript.

10 A, 44 a.

GREAT PRIMER MANUSCRIPT No. 1. (D)

\$6.00

In presenting this Script for the approval of Job Printers, we desire to call attention to several points considered while producing it. Legibility was secured by simplicity and strength in shaping letters. Durability, by an almost entire absence of kerned letters was

10 A, 40 a.

GREAT PRIMER MANUSCRIPT No. 2.

\$6.00

In presenting this Script for approval of Job Printers, we desire to call attention to several points considered while producing it. Legibility was secured by simplicity and

A A B B D E F G H I J K L M N O P Q R S T t h

Separate Lower Cases, either style, \$3.85 each.

6 A, 22 a.

DOUBLE PICA MANUSCRIPT No. 1.

\$7.00

The business of transcribing the remains of Roman and Grecian literature, became a useful, innocent, and a pleasing employ to many of those who

6 A, 20 a.

DOUBLE PICA MANUSCRIPT No. 2.

\$7.00

The business of transcribing the remains of Roman and Grecian literature, became a useful

A A B B D E F G H I J K L M N O
t h t t 1 2 3 4 5 6 7 8 9 0 @ C C C

Separate Lower Cases, either style, \$4.00 each.

MISCELLANEOUS SCRIPTS.

PICA LAKESIDE SCRIPT No. 2. (B) 8 A, 40 a. \$5.00

The Board of City Insurers
Foreign and Domestic Steel &

GT. PRIM. LAKESIDE SCRIPT No. 2. 6 A, 30 a. \$5.25

New Cabinet Furniture
Printers' Warehouses &

4 A, 20 a.

DOUBLE PICA ROUND FACE SCRIPT. (F)

\$8.00

Merchants International Exposition

PICA LAKESIDE SCRIPT. (B)

8 A 40 a. \$5.25

16 A, 80 a. \$10.00

The continued and liberal patronage extended to us by our many Friends and the Public

GREAT PRIMER LAKESIDE SCRIPT.

6 A, 30 a. \$5.50

12 A, 60 a. \$10.25

Plain and Fancy Letter,
Flourishes, Borders, etc.

DBL. PICA LAKESIDE SCRIPT. 4 A, 20 a. \$5.75

Cincinnati
Type and Presses

DBL. GT. PRIM. LAKESIDE SCRIPT. 3 A, 10 a. \$6.00

Nonpareil
Cylinder Press

8 A, 24 a.

PARAGON PENCILINGS No. 2. (M)

\$5.85

Breath from Heaven sent to lessen the misery of Unlucky

8 A, 24 a.

PARAGON PENCILINGS No. 1.

\$6.65

Hold your Councils at the Feast of the Pentecost

3 A, 8 a.

DOUBLE GREAT PRIMER CHICAGO SCRIPT. (M)

\$6.00

Democratic Ratification.

PICA SPINNER SCRIPT. (M) 6 A, 25 a. \$3.25

The Fourth Annual Meeting of the Stockholders of the Southern Railroad will be held August 25th. at

GT. PRIMER SPINNER SCRIPT. 6 A, 16 a. \$4.35

Grand Military Drill at Chester Hall, June 24th.

4 A, 12 a. \$4.75

DBL. PICA SPINNER SCRIPT.

8 A, 50 A. \$12.50

We invite the attention of all Stationers,
Booksellers and General Dealers to a fine

Quads and Spaces extra.

168

Cincinnati Type Foundry, 201 Vine St.

MAR 21 1958

