

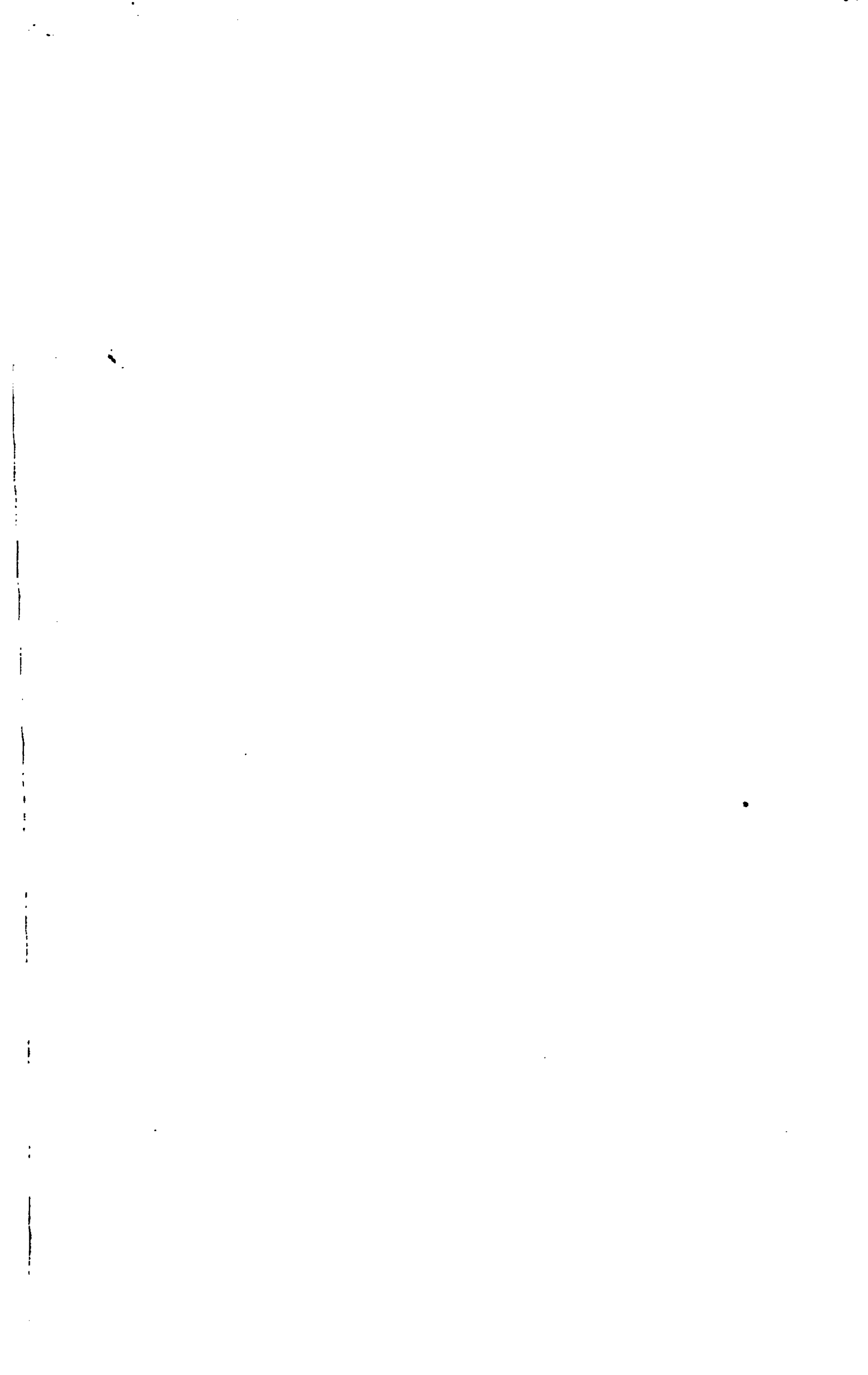

THE GIFT OF

Bence type co.

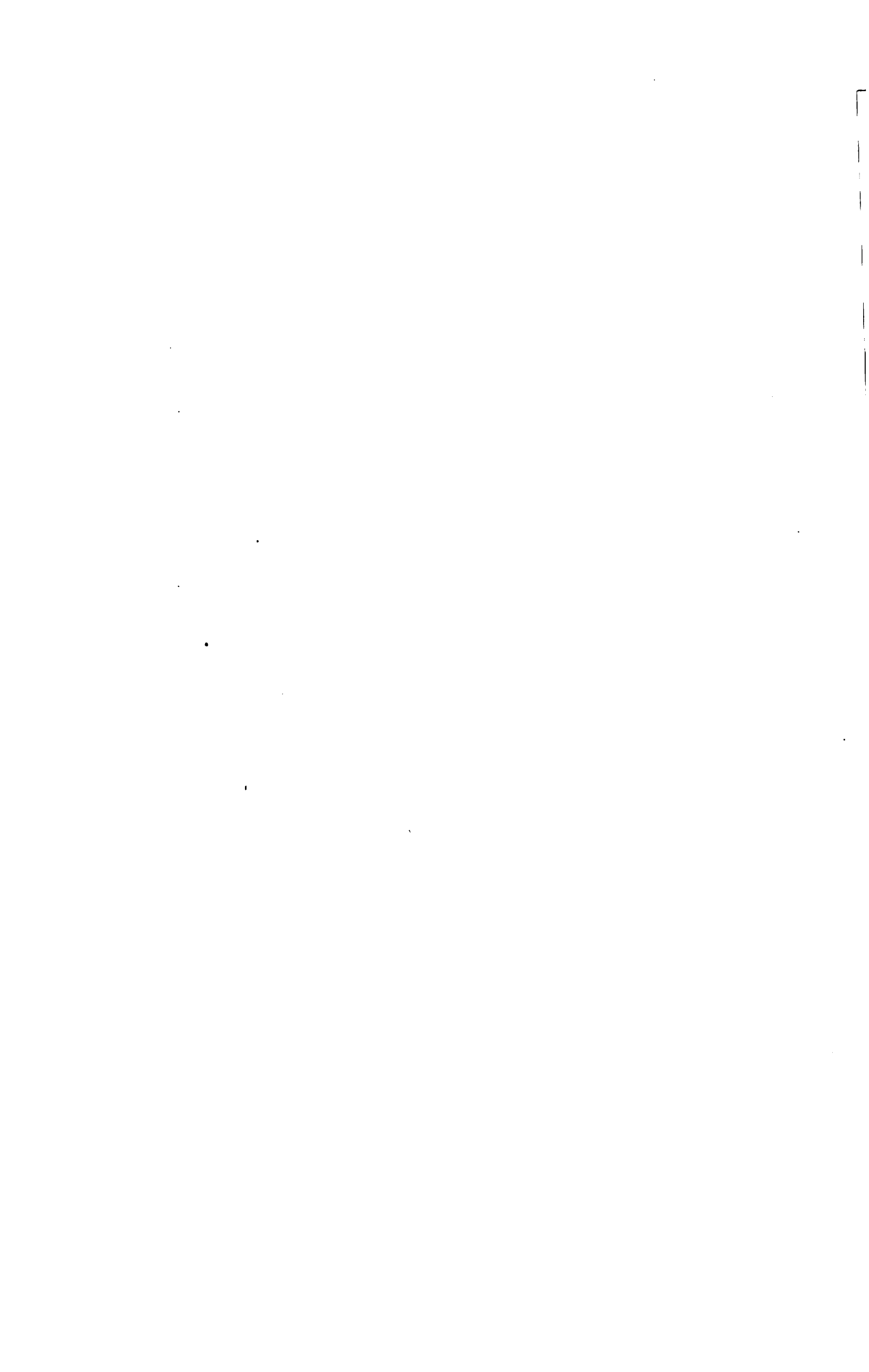



IF SELECTIONS ARE MADE FROM THIS HANDY-BOOK
IT WILL INSURE MORE PROMPT DELIVERY THAN
IF MADE FROM ANY OLDER EDITION.

ESTABLISHED IN 1813



LOCATED IN THIS BUILDING FOR THE
PAST EIGHTY-SIX YEARS

BRUCE TYPE FOUNDRY



OUR HANDY BOOK OF
TYPES, BORDERS
BRASS RULE AND CUTS
PRINTING MACHINERY
& GENERAL SUPPLIES



BRUCE TYPE
FOUNDRY
13 CHAMBERS STREET
NEW YORK, U. S. A.

**BRUCE QUALITY
BEST QUALITY**



7
2
123

To Our Many Patrons

IN this HANDY SPECIMEN BOOK is combined the contents of all previous books and supplements, and shows all our productions adapted to the point system. Type cast to the point system only is carried in stock, but orders for same on old bodies will be filled on reasonable notice.

Since commencing work on this book it was decided to change the bodies and schemes of some fonts so as to give the printer type on bodies most in use. Besides changing the bodies of a number of our scripts, we have added card fonts to same. All fonts changed either in body or scheme are shown in the index marked with a star (*) so as to avoid mistakes.

In making orders do not mutilate the book. Prices and numbers are annexed to all articles and giving same together with the page number on which same is shown is sufficient for a correct understanding of any order sent us.

The well-known "Bruce Quality," both in metal and workmanship, will always be maintained, and we point with pride to the fact that since the foundation of this house, nearly a century ago, "Bruce" product has never been equalled by any type foundry in the world.

Acknowledging the loyal support of our old customers, both domestic and foreign, in the past, we respectfully solicit a continuance of same in the future, pledging our best efforts to merit their favor and confidence.

BRUCE TYPE FOUNDRY

14 Sept. 09
 1000 2000 3000 4000 5000 6000 7000 8000 9000 10000

INDEX TO TYPE SPECIMENS AND CORRECTED PRICE-LIST

Having made a number of changes in casting and fonting the type shown herein since starting work on this specimen book, we give on the succeeding pages the corrected prices, schemes and bodies changed. All fonts which have been changed either in body or scheme and on scripts where card fonts have been added are marked with an asterisk (*) so as to avoid mistakes. Customers should watch this carefully when ordering. All type will be furnished on new bodies as per this price list, unless otherwise specified.

				PAGE
ACCENTS—JOB, PIECE, ROMAN, SCRIPT				3
ALAINE NO. 1559				272
*8 Pt.....	20A	\$1.25,	40a \$1.25	\$2.50
*10.....	15A	1.40,	30a 1.35	2.75
*12.....	12A	1.55,	25a 1.45	3.00
*18.....	10A	1.80,	15a 1.70	3.50
*24.....	8A	2.30,	12a 2.20	4.50
*36.....	6A	3.25,	10a 3.25	6.50
ALDINE NO. 161				122, 123
5 Pt.....	30A	\$1.25,	60a \$1.25	\$2.50
6.....	30A	1.25,	60a 1.20	2.45
7.....	30A	1.30,	60a 1.30	2.60
8.....	30A	1.55,	60a 1.50	3.05
10.....	20A	1.35,	40a 1.35	2.70
12.....	15A	1.35,	30a 1.30	2.65
18.....	12A	2.00,	25a 1.90	3.90
*24.....	10A	2.30,	20a 2.20	4.50
*30.....	8A	2.80,	15a 2.70	5.50
*36.....	6A	3.30,	12a 3.20	6.50
*48.....	5A	5.10,	10a 4.90	10.00
72.....	5A	10.00,	5a 6.40	16.40
96.....	4A	15.00,	4a 9.25	24.25
ANTIQUE NO. 300				163
8 Pt.....	30A	\$1.75,	60a \$1.75	\$3.50
10.....	20A	1.55,	40a 1.50	3.05
12.....	15A	1.50,	30a 1.40	2.90
18.....	12A	2.35,	25a 2.30	4.65
24.....	10A	3.30,	20a 3.30	6.60
*36.....	5A	4.15,	10a 4.10	8.25
48.....	5A	6.00,	5a 3.10	9.10
ANTIQUE NO. 301				164, 165
5½ Pt.....	30A	\$1.35,	60a \$1.35	\$2.70
6.....	30A	1.55,	60a 1.50	3.05
8.....	30A	1.95,	60a 1.90	3.85
10.....	20A	1.40,	40a 1.35	2.75
12.....	15A	1.50,	30a 1.40	2.90
18.....	12A	2.35,	25a 2.25	4.60
*24.....	10A	2.80,	20a 2.70	5.50
*30.....	8A	3.50,	15a 3.25	6.75
*36.....	6A	4.40,	12a 4.10	8.50
ANTIQUE NO. 302				166, 167
5 Pt.....	30A	\$1.00,	60a \$1.55	\$3.15
6.....	30A	1.55,	60a 1.50	3.05
8.....	30A	1.75,	60a 1.65	3.40
10.....	20A	1.50,	40a 1.45	2.95
12.....	15A	1.55,	30a 1.50	3.05
18.....	12A	2.35,	25a 2.30	4.65
*24.....	10A	2.70,	20a 2.80	5.50

				PAGE
ANTIQUE NO. 302..CONTINUED				166, 167
*30.....	8A	\$3.40,	15a \$3.35	\$6.75
36.....	8A	5.00,	15a 4.75	9.75
48.....	5A	7.00,	5a 3.65	10.65
84.....	4A	15.75,	15.75
ANTIQUE NO. 304				169
6 Pt.....	30A	\$1.40,	60a \$1.40	\$2.80
8.....	30A	1.95,	60a 1.90	3.85
9.....	20A	1.35,	40a 1.25	2.60
10.....	20A	1.70,	40a 1.65	3.35
11.....	20A	1.70,	40a 1.65	3.35
12.....	15A	1.80,	30a 1.70	3.50
ANTIQUE NO. 305				170
6 Pt.....	30A	\$1.50,	60a \$1.40	\$2.90
ANTIQUE NO. 306				170
6 Pt.....	30A	\$1.25,	60a \$1.20	\$2.45
8.....	30A	1.65,	60a 1.60	3.25
10.....	30A	1.45,	40a 1.35	2.80
12.....	15A	1.55,	30a 1.45	3.00
18.....	12A	2.40,	25a 2.25	4.65
ANTIQUE NO. 307				171
18 Pt.....	12A	\$2.60,	25a \$2.50	\$5.10
20.....	12A	2.75,	25a 2.65	5.40
22.....	12A	3.80,	25a 3.60	7.40
24.....	10A	3.35,	20a 3.25	6.60
*36.....	6A	6.00,	10a 4.00	10.00
*42.....	5A	6.85,	8a 5.65	12.50
ANTIQUE CONDENSED NO. 321				178, 179
6 Pt.....	30A	\$1.15,	60a \$1.15	\$2.30
8.....	20A	1.55,	60a 1.50	3.05
10.....	20A	1.20,	40a 1.20	2.40
12.....	15A	1.20,	30a 1.20	2.40
18.....	12A	1.85,	25a 1.85	3.70
*24.....	10A	2.35,	20a 2.25	4.60
*30.....	8A	2.85,	15a 2.75	5.60
36.....	8A	3.40,	15a 3.25	6.65
48 A.....	7A	5.00,	12a 4.50	9.50
48 B.....	5A	3.25,	5a 2.35	5.60
60.....	5A	6.00,	5a 3.90	9.90
96.....	4A	8.00,	4a 5.00	13.00
ANTIQUE CONDENSED NO. 323				181
12 Pt.....	15A.....			\$1.00
20.....	12A.....			1.60
24.....	10A.....			1.90
36.....	8A.....			3.30
48.....	5A.....			3.25

* Fonts either changed in body or scheme.

				PAGE					PAGE		
ANTIQUE CONDENSED NO. 324				185	BINNER GOTHIC..CONTINUED				272 P		
8 Pt.....	30A	\$1.25,	60a	\$1.25	\$2.50	36.....	10A	\$3.15,	15a	\$2.85	\$6.00
10.....	20A	1.25,	40a	1.25	2.50	48.....	8A	3.70,	12a	3.30	7.00
12.....	15A	1.05,	30a	1.00	2.05	60.....	7A	4.30,	10a	3.70	8.00
18.....	12A	1.70,	25a	1.60	3.30	72.....	5A	4.80,	5a	4.20	9.00
ANTIQUE EXTENDED NO. 330				129	BINNER SERIES				208 A, B, C		
6 Pt.....	15A	\$1.50,	30a	\$1.55	\$3.05	6 Pt.....	24A	\$1.40,	36a	\$1.10	\$2.50
8.....	15A	2.00,	30a	2.05	4.05	8.....	22A	1.55,	30a	1.20	2.75
10.....	10A	1.70,	20a	1.75	3.45	10.....	20A	1.70,	26a	1.30	3.00
12.....	10A	2.25,	20a	2.35	4.60	12.....	16A	1.95,	20a	1.30	3.25
ANTIQUE EXTENDED NO. 331				193	18.....	10A	2.10,	16a	1.90	4.00	
5 Pt.....	30A			\$2.25	24.....	8A	2.70,	10a	1.80	4.50	
ANTIQUE EXTENDED NO. 332				182	30.....	6A	2.90,	9a	2.10	5.00	
5 Pt.....	30A			\$2.50	36.....	5A	3.00,	8a	2.50	5.50	
6.....	30A			2.30	48.....	4A	4.90,	5a	2.85	7.75	
8.....	30A			2.60	54.....	4A	6.50,	5a	3.75	10.25	
10.....	20A			2.30	60.....	4A	7.50,	5a	4.75	12.25	
12.....	15A			2.40	72.....	4A	10.35,	5a	6.65	17.00	
16.....	15A			3.70	BLACK ORNATE NO. 516					295	
20.....	12A			4.95	22 Pt.....	8A	\$2.30,	25a	\$2.20	\$4.50	
24.....	8A			4.50	28.....	7A	3.10,	20a	2.90	6.00	
*30.....	6A			5.75	BLACK ORNATE SHADED NO. 517					295	
ANTIQUE EXTRA CONDENSED NO. 631				183	22 Pt.....	8A	\$2.20,	25a	\$2.30	\$4.50	
48 Pt.....	5A	\$5.00,	5a	\$3.75	\$8.75	28.....	7A	3.00,	20a	2.80	5.80
60.....	5A	8.00,	5a	5.60	13.60	BLACK ORNATE NO. 532				303	
84.....	4A	13.00,	4a	7.70	20.70	24 Pt.....	7A	\$3.50,	20a	\$3.25	\$6.75
ANTIQUE EXTRA CONDENSED NO. 632				184, 185	36.....	6A	5.20,	15a	4.75	9.95	
8 Pt.....	30A	\$1.90,	60a	\$1.90	\$3.80	48.....	5A	7.20,	12a	6.30	13.50
10.....	20A	1.55,	40a	1.55	3.10	BLACK ORNATE NO. 538				307	
12.....	15A	1.55,	30a	1.50	3.05	12 Pt.....	10A	\$2.20,	30a	\$2.45	\$4.65
18.....	12A	1.90,	25a	1.85	3.75	18.....	8A	2.85,	25a	3.00	5.85
*24.....	10A	2.40,	20a	2.35	4.75	24.....	7A	4.15,	20a	4.25	8.40
*30.....	10A	3.25,	20a	3.20	6.45	36.....	6A	5.85,	15a	6.25	12.10
*42.....	8A	3.00,	15a	3.80	7.70	BLACK ORNATE TEXT NO. 512				291	
48.....	7A	4.00,	12a	3.65	7.65	132 Pt.....	3A	\$16.00,	5a	\$13.95	\$29.95
ANTIQUE EXTRA CONDENSED NO. 634				186	BLACK RIMMED NO. 533					304	
6 Pt.....	30A			\$1.25	24 Pt.....	7A	\$3.75,	20a	\$4.00	\$7.75	
8.....	30A			1.80	36.....	6A	4.45,	15a	5.00	9.45	
10.....	20A			1.65	BLACK RIM SHADED NO. 535					306	
12.....	15A			1.60	22 Pt.....	8A	\$3.85,	25a	\$4.15	\$8.00	
18.....	12A			2.00	28.....	7A	4.65,	20a	5.00	9.65	
24.....	10A			2.50	36.....	6A	5.70,	15a	6.00	11.70	
36.....	8A			3.80	48.....	5A	6.50,	12a	7.50	14.00	
48.....	5A			3.70	BLACK TEXT NO. 401					283	
ANTIQUE POINTED NO. 309				173	72 Pt.....	3A	\$6.80,	5a	\$6.00	\$12.80	
12 Pt.....	15A	\$2.10,	30a	\$2.00	\$4.10	BLACK TEXT OPEN NO. 501				283	
18.....	12A	3.15,	25a	3.00	6.15	72 Pt.....	3A	\$6.50,	5a	\$5.75	\$12.25
*24.....	12A	4.00,	25a	3.70	7.70	BLACK TEXT OPEN NO. 502				283	
*30.....	10A	4.65,	20a	4.50	9.15	72 Pt.....	3A	\$6.50,	5a	\$5.75	\$12.25
APOTHECARIES' SIGNS				7	BLACK TEXT OPEN NO. 509					287	
ARLINGTON SERIES				208 J-L	96 Pt.....	3A	\$10.50,	5a	\$9.30	\$19.80	
10 Pt.....	20A	\$1.50,	26a	\$1.25	\$2.75	BODY TYPE					
12.....	16A	1.70,	20a	1.30	3.00	German.....				82-91	
18.....	10A	1.70,	16a	1.55	3.25	Modern Roman.....				15-69	
24.....	8A	2.30,	10a	1.70	4.00	Old Style Roman.....				70-79	
30.....	6A	2.70,	9a	2.30	5.00	BORDERS				354-377	
36.....	5A	3.00,	8a	2.50	5.50	6 Pt., Six Feet Font.....				\$2.00	
48.....	4A	4.65,	5a	3.10	7.75	9 " " " ".....				2.00	
60.....	4A	5.10,	5a	3.80	8.90	12 " " " ".....				2.25	
72.....	3A	6.75,	4a	4.40	11.15	18 " " " ".....				2.80	
ASTRONOMICAL SIGNS				9	24 " " " ".....					1.65	
AUGUSTAN BLACK NO. 504				284	36 " " " ".....					2.25	
8 Pt.....	20A	\$2.25,	60a	\$2.15	\$4.40	48 " " " ".....				1.50	
10.....	14A	1.80,	40a	1.95	3.75	60 " " " ".....				1.75	
12.....	10A	2.15,	30a	2.05	4.20	Combination No. 13.....				\$5.45	374
18.....	8A	2.75,	25a	2.60	5.35	" " " " 16.....				5.45	375
24.....	7A	3.60,	20a	3.35	6.95	" " " " 21.....				4.50	376
BINNER GOTHIC				272 P	" " " " 70.....					3.00	377
18 Pt.....	18A	\$1.75,	27a	\$1.50	\$3.25						
24.....	14A	2.20,	20a	1.80	4.00						
30.....	12A	2.60,	18a	2.40	5.00						

* Fonts either changed in body or scheme.

				PAGE					PAGE
CIRCULAR NO. 682				320	CONDENSED NO. 162				124
18 Pt.....	30A	\$3.50,	60a \$10.50	\$14.00	8 Pt.....	30A	\$1.30,	60a \$1.30	\$2.60
*24.....	25A	3.00,	50a 9.60	12.60	10.....	20A	1.00,	40a .95	1.95
CIRCULAR ITALIC NO. 1527				250	12.....	15A	1.15,	30a 1.10	2.25
12 Pt.....	15A	\$2.50,	30a \$1.40	\$3.90	14.....	15A	1.20,	30a 1.15	2.35
18.....	12A	3.40,	25a 2.00	5.40	CONDENSED NO. 163				125
24.....	10A	4.65,	20a 3.00	7.65	10 Pt.....	20A	\$1.05,	40a \$1.00	\$2.05
36.....	8A	7.20,	15a 5.00	12.20	12.....	15A	.99,	30a .99	1.80
48.....	5A	6.00,	5a 4.10	10.10	20.....	12A	1.60,	25a 1.40	3.00
CLARENDON NO. 322				180	24.....	10A	1.75,	20a 1.60	3.35
6 Pt.....	30A	\$1.20,	60a \$1.10	\$2.30	*30.....	9A	2.35,	18a 2.15	4.50
8.....	20A	1.40,	60a 1.20	2.60	36.....	8A	3.00,	15a 2.75	5.75
10.....	20A	1.20,	40a 1.00	2.20	CONDENSED NO. 164				126, 127
12.....	15A	1.25,	30a 1.05	2.30	6 Pt.....	30A	\$1.05,	60a \$1.00	\$2.05
18.....	12A	1.75,	25a 1.50	3.25	8.....	30A	1.40,	60a 1.30	2.70
*24.....	10A	2.50,	20a 2.00	4.50	10.....	20A	1.20,	40a 1.00	2.20
*30.....	8A	3.00,	15a 2.50	5.50	12.....	15A	1.20,	20a 1.10	2.30
CLARENDON CONDENSED NO. 320				176, 177	18.....	12A	1.70,	25a 1.60	3.30
10 Pt.....	20A	\$1.20,	40a \$1.10	\$2.30	*24.....	10A	2.30,	20a 2.20	4.50
12.....	15A	1.20,	30a 1.10	2.30	*30.....	9A	2.80,	18a 2.65	5.45
16.....	15A	1.70,	30a 1.40	3.10	36.....	8A	3.50,	15a 3.35	6.85
18.....	12A	1.75,	25a 1.50	3.25	48.....	7A	6.00,	12a 5.45	11.45
*24.....	10A	2.50,	20a 2.05	4.55	CONDENSED NO. 600				108
*30.....	9A	3.00,	18a 2.50	5.50	16 Pt.....	15A			\$1.85
36.....	8A	3.35,	15a 2.75	6.10	24.....	10A			2.70
*42.....	7A	5.00,	12a 4.30	9.30	40.....	8A			3.60
48.....	7A	6.50,	12a 5.45	11.95	CONDENSED BLACK TEXT NO. 506				286, 287
COATS OF ARMS				408	14 Pt.....	10A	\$1.95,	30a \$1.85	\$3.80
COMMERCIAL SIGNS				7	18.....	8A	2.10,	25a 2.00	4.10
CONDENSED NO. 121				106	*30.....	7A	3.25,	20a 3.00	6.25
9 Pt.....	20A			\$0.90	36.....	6A	4.10,	15a 3.70	7.80
10.....	20A			1.10	48.....	5A	6.10,	12a 5.60	11.70
12.....	15A			1.10	72.....	3A	6.95,	5a 6.00	12.95
16.....	12A			1.30	96.....	3A	9.25,	5a 8.25	17.50
20.....	12A			1.95	CONDENSED HAIRLINE NO. 647				315
24.....	10A			2.20	12 Pt.....	15A	\$1.20,	30a \$1.10	\$2.30
28.....	10A			2.30	COPPERPLATE SCRIPT NO. 2002				330, 331
36.....	8A			2.90	*36 Pt. Card Font.	3A	\$4.75,	8a \$3.25	\$8.00
CONDENSED NO. 122				107	*48 " " "	3A	7.00,	8a 5.00	12.00
10 Pt.....	20A			\$1.20	36 " Circular "	6A	7.50,	15a 7.25	14.75
12.....	15A			1.15	48 " " "	5A	11.00,	12a 9.50	20.50
16.....	15A			1.60	COPPERPLATE SCRIPT NO. 2003				330, 332
18.....	12A			1.95	36 Pt. Card Font.	3A	\$4.25,	8a \$3.50	\$7.75
20.....	12A			2.20	48 " " "	3A	6.25,	8a 4.25	10.50
22.....	12A			2.65	36 " Circular "	10A	11.00,	30a 10.30	21.30
24.....	10A			2.60	48 " " "	6A	10.15,	15a 9.00	19.15
CONDENSED NO. 123				108	COPPERPLATE SCRIPT NO. 2005				334
28 Pt.....	10A			\$3.50	*18 Pt. Card Font.	4A	\$2.00,	10a \$1.25	\$3.25
36.....	8A			4.50	18 " Circular "	9A	3.50,	97a 10.10	13.60
CONDENSED NO. 124				109	COPPERPLATE SCRIPT NO. 2006				334
9 Pt.....	20A			\$0.90	*24 Pt. Card Font.	4A	\$2.25,	10a \$1.50	\$3.75
10.....	20A			1.10	*24 " Circular "	7A	9.65,	56a 3.75	13.40
16.....	15A			1.65	DELAWARE NO. 1571				279
20.....	12A			1.95	12 Pt.....	15A	\$1.75,	15a \$1.00	\$2.75
24.....	10A			2.65	18.....	12A	2.50,	12a 1.50	4.00
CONDENSED NO. 125				110, 114	24.....	10A	3.00,	10a 1.60	4.60
10 Pt.....	20A			\$1.10	30.....	8A	3.45,	8a 2.00	5.45
12.....	15A			1.10	36.....	6A	4.00,	6a 2.35	6.35
16.....	15A			1.60	48.....	5A	4.45,	5a 3.00	7.45
48.....	5A			4.15	DE VINNE CONDENSED				272 H-K
60.....	5A			6.50	6 Pt.....	30A	\$1.25,	42a \$1.00	\$2.25
72.....	5A			9.10	8.....	25A	1.40,	36a 1.10	2.50
96.....	4A			13.00	10.....	22A	1.40,	30a 1.35	2.75
CONDENSED NO. 126				111, 112	12.....	18A	1.60,	22a 1.40	3.00
10 Pt.....	20A			\$1.30	14.....	12A	1.75,	20a 1.50	3.25
12.....	15A			1.15	18.....	10A	1.60,	16a 1.65	3.25
14.....	15A			1.40	24.....	8A	2.10,	12a 1.90	4.00
16.....	15A			2.05	30.....	6A	2.50,	9a 2.00	4.50
18.....	12A			1.70	36.....	5A	2.60,	8a 2.40	5.00
20.....	12A			2.20	42.....	4A	3.00,	6a 2.50	5.50
22.....	12A			2.55	48.....	4A	3.25,	5a 2.75	6.00
24.....	10A			2.45	54.....	4A	4.50,	5a 3.00	7.50
*30.....	9A			3.25	60.....	4A	6.00,	5a 4.00	10.00
36.....	8A			3.85	72.....	4A	8.75,	5a 6.25	15.00

* Fonts either changed in body or scheme.

INDEX TO TYPE SPECIMENS AND CORRECTED PRICE LIST.

v

				PAGE
DE VINNE EXTENDED				272 A-C
6 Pt.	24A	\$1.30,	36a \$1.20	\$2.50
8	22A	1.50,	30a 1.25	2.75
10	18A	1.65,	24a 1.35	3.00
12	14A	2.00,	18a 1.50	3.50
14	10A	2.00,	14a 1.75	3.75
18	9A	2.50,	12a 2.00	4.50
24	6A	3.00,	10a 3.00	6.00
30	5A	4.00,	8a 3.00	7.00
36	4A	4.50,	6a 3.50	8.00
42	4A	5.75,	5a 4.25	10.00
48	3A	7.00,	4a 4.50	11.50
54	3A	7.50,	4a 5.50	13.00
60	3A	9.75,	4a 6.25	16.00
72	3A	13.00,	4a 8.00	21.00
DE VINNE EXTRA CONDENSED				272 L, M
12 Pt.	20A	\$1.60,	26a \$1.40	\$3.00
14	18A	1.60,	22a 1.65	3.25
18	12A	1.55,	20a 1.70	3.25
24	10A	2.00,	16a 2.00	4.00
30	8A	2.50,	12a 2.50	5.00
36	6A	2.05,	12a 3.45	5.50
42	6A	3.00,	10a 3.00	6.00
48	5A	3.50,	8a 3.50	7.00
54	5A	4.25,	7a 3.75	8.00
60	4A	5.25,	5a 3.75	9.00
72	4A	8.75,	5a 6.25	15.00
DE VINNE ITALIC				272 N, O
6 Pt.	24A	\$1.25,	36a \$1.00	\$2.25
8	24A	1.40,	30a 1.10	2.50
10	20A	1.45,	26a 1.30	2.75
12	16A	1.60,	20a 1.40	3.00
14	12A	1.75,	18a 1.50	3.25
18	10A	2.10,	16a 1.90	4.00
24	8A	2.50,	10a 2.00	4.50
30	6A	3.00,	9a 2.75	5.75
36	5A	3.50,	8a 3.00	6.50
42	4A	4.00,	6a 3.25	7.25
48	4A	4.50,	5a 3.25	7.75
54	4A	6.60,	5a 4.65	11.25
60	4A	7.85,	5a 5.40	13.25
72	4A	11.20,	5a 7.80	19.00
DE VINNE SERIES				272 B-G
5½ Pt.	24A	\$1.35,	36a \$1.15	\$2.50
6	24A	1.25,	36a 1.00	2.25
7	22A	1.30,	34a 1.20	2.50
8	22A	1.40,	30a 1.10	2.50
10	20A	1.50,	26a 1.25	\$2.75
12	16A	1.70,	20a 1.30	3.00
14	12A	1.75,	18a 1.50	3.25
18	10A	1.70,	16a 1.55	3.25
24	6A	2.30,	10a 1.70	4.00
30	6A	2.70,	9a 2.30	5.00
36	5A	3.00,	8a 2.50	5.50
42	4A	4.00,	6a 3.25	7.25
48	4A	4.65,	5a 3.10	7.75
54	4A	6.00,	5a 4.25	10.25
60	4A	7.25,	5a 5.00	12.25
72	4A	10.00,	5a 7.00	17.00
DEVIC NO. 303				163
6 Pt.	30A	\$1.55,	60a \$1.50	\$3.05
8	30A	1.90,	60a 1.80	3.70
10	20A	1.85,	40a 1.75	3.60
12	15A	2.05,	30a 2.00	4.05
18	12A	3.00,	25a 2.80	5.80
24	10A	4.40,	20a 4.30	8.70
36	8A	6.65,	15a 6.50	13.15
DEVIC ITALIC				208 P
6 Pt.	18A	\$1.80,	40a \$1.70	\$3.50
8	15A	2.00,	30a 1.75	3.75
10	12A	2.10,	25a 1.90	4.00
12	10A	2.25,	20a 2.00	4.25
18	8A	2.50,	12a 2.00	4.50
24	6A	2.65,	10a 2.35	5.00
30	5A	3.70,	7a 2.80	6.50
36	5A	5.00,	7a 3.75	8.75
48	4A	6.60,	5a 4.15	10.75
60	4A	9.50,	5a 6.00	15.50

				PAGE	
ELECTROTYPES				402-448	
Check Blanks				405	
Coats of Arms				408	
Head and Tail Pieces				438-440	
Index				445	
Initials				402, 403	
Miscellaneous Cuts				406	
Newspaper Headings				446-448	
Ornaments				437	
Society				443	
State Seals				407	
Trade Cuts				412-436	
United States Emblems				441	
United States Flags				442	
ELONGATED ITALIC NO. 190				134	
48 Pt.	5A	\$5.30,	10a \$5.25	\$10.55	
84	4A	9.00,	4a 6.00	15.00	
ELZEVR GOTHIC				208 N, O	
6 Pt.	25A	\$1.15,	50a \$1.35	\$2.50	
8	22A	1.25,	44a 1.50	2.75	
10	20A	1.35,	40a 1.65	3.00	
12	18A	1.50,	36a 2.00	3.50	
14	15A	1.75,	30a 2.25	4.00	
18	12A	2.25,	24a 2.25	4.50	
24	8A	2.50,	16a 2.50	5.00	
30	6A	2.65,	12a 2.85	5.50	
36	5A	3.00,	9a 3.00	6.00	
48	3A	4.00,	6a 4.00	8.00	
60	3A	6.50,	5a 5.00	11.50	
ELZEVR ITALIC NO. 654				80, 81	
6 Pt.	30A	\$1.35,	60a \$1.10	\$2.45	
8	30A	1.50,	60a 1.30	2.80	
10	20A	1.30,	40a 1.00	2.30	
12	15A	1.50,	30a 1.05	2.55	
18	12A	2.50,	25a 1.40	3.90	
*24	10A	3.25,	20a 2.50	5.75	
36	8A	5.00,	15a 3.60	8.60	
ENGRAVERS' HAIRLINE NO. 644				315	
5 Pt.	30A	\$2.00,	30A \$1.40,	60a \$1.50	\$4.90
6	30A	2.50,	30A 1.60,	60a 1.90	6.00
10	20A	1.90,	30A 1.35,	40a 1.45	4.70
ENGRAVERS' ITALIC NO. 145				118	
6 Pt.	30A	\$1.60,	60a \$1.45	\$3.05	
8	30A	1.90,	60a 1.70	3.60	
10	20A	1.75,	40a 1.50	3.25	
12	15A	1.60,	30a 1.30	2.90	
ENGROSSING NO. 681				319	
12 Pt.	10A	\$1.90,	30a \$1.15	\$3.05	
18	8A	2.70,	25a 1.40	4.10	
24	7A	3.85,	20a 2.00	5.85	
36	6A	5.00,	15a 3.40	8.40	
48	5A	7.00,	12a 4.50	11.50	
ERASED NO. 19				13	
ERASED ITALIC NO. 19				14	
ESSEX OLD STYLE NO. 1091				235	
12 Pt.	15A			\$2.05	
18	12A			2.90	
24	10A			4.05	
36	8A			7.40	
48	5A			6.85	
EXPANDED NO. 180				128, 129	
5 Pt.	30A	\$2.30,	60a \$2.20	\$4.50	
5½	30A			1.80	
6	30A	2.00,	60a 1.80	3.80	
8	30A	2.45,	60a 2.30	4.75	
10	20A	2.20,	40a 1.95	4.15	
12	15A	2.40,	30a 2.20	4.60	
18	12A	3.80,	25a 3.40	7.20	
24	10A			5.30	
EXTENDED BLACK TEXT NO. 513				292	
8 Pt.	20A	\$3.10,	60a \$3.10	\$6.20	
10	14A	2.75,	40a 2.75	5.50	
12	10A	2.75,	30a 2.75	5.50	
18	8A	4.00,	25a 4.00	8.00	
24	7A	5.50,	20a 5.30	10.80	
36	6A	8.50,	15a 8.20	16.70	

* Fonts either changed in body or scheme.

				PAGE					PAGE		
EXTENDED BLACK TEXT OPEN NO. 514				293	GERMAN OPEN NO. 590				97		
18 Pt.	8A	\$4.00,	25a	\$4.00	\$8.00	*12 Pt.	10A	\$2.35,	30a	\$2.45	\$4.80
24	7A	5.50,	20a	5.30	10.80	16	10A	4.05,	30a	4.15	8.20
36	6A	8.40,	15a	8.20	16.60	24	7A	4.20,	20a	4.35	8.55
						*30	6A	5.90,	15a	6.15	12.05
EXTENDED RUNIC NO. 643				193	GERMAN TEXT NO. 580				313, 314		
8 Pt.	30A	\$1.70,	60a	\$1.80	\$3.50	18 Pt.	8A	\$3.25,	25a	\$1.75	\$5.00
10	20A	1.50,	40a	1.30	2.80	*24	8A	4.50,	25a	2.70	7.20
12	15A	1.50,	30a	1.65	3.15	*42	5A	5.75,	12a	3.75	9.50
18	12A	2.15,	25a	2.30	4.45	48	3A	8.00,	5a	3.50	11.50
						84	3A	12.00,	5a	6.00	18.00
EXTRA CONDENSED NO. 601				124	GERMAN TITLE NO. 490				92, 93		
60 Pt.	5A	\$7.50,	5a	\$5.00	\$12.50	6 Pt.	20A	\$1.70,	60a	\$1.80	\$3.50
84	4A	13.45,	4a	8.00	21.45	7	20A	1.70,	60a	1.80	3.50
EXTRA CONDENSED NO. 602				131	GOTHIC NO. 200				187, 188		
8 Pt.	30A	\$1.75,	60a	\$1.65	\$3.40	6 Pt.	30A				\$2.05
10	20A	1.40,	40a	1.20	2.60	8	30A				1.80
12	15A	1.20,	30a	1.10	2.30	10	20A				1.50
EXTRA CONDENSED NO. 603				132, 133	GOTHIC NO. 201				139		
8 Pt.	30A	\$1.45,	60a	\$1.55	\$3.00	6 Pt.	30A	\$1.10,	60a	\$1.10	\$2.20
10	20A	1.20,	40a	1.25	2.45	8	30A	1.40,	60a	1.40	2.80
12	15A	1.10,	30a	1.20	2.30	10	20A	1.15,	40a	1.10	2.25
18	12A	1.35,	25a	1.55	2.90	12	15A	1.15,	30a	1.10	2.25
*24	10A	1.75,	20a	1.85	3.60	18	12A	1.95,	25a	1.90	3.85
*30	9A	2.10,	18a	2.30	4.40	24	10A	2.95,	20a	2.85	5.80
36	8A	2.50,	15a	2.70	5.20	GOTHIC NO. 202				140, 141	
48	6A	2.55,	12a	2.85	5.40	6 Pt.	30A	\$1.25,	60a	\$1.20	\$2.45
60	5A	3.00,	10a	3.40	6.40	8	30A	1.55,	60a	1.50	3.05
EXTRA CONDENSED BLACK TEXT NO. 526				299	GOTHIC NO. 203				142		
24 Pt.	7A	\$1.40,	20a	\$2.20	\$3.60	5 Pt.	30A	\$2.00,	60a	\$1.60	\$3.60
36	6A	2.00,	15a	3.00	5.00	6	30A	1.90,	60a	1.45	3.35
48	5A	2.85,	12a	4.00	6.85	8	30A	2.50,	60a	1.80	4.30
FAULKNER NO. 207				147	GOTHIC NO. 204				143		
6 Pt.	30A	\$1.05,	60a	\$1.00	\$2.05	12 Pt.	15A	\$1.25,	30a	\$1.25	\$2.50
8	30A	1.25,	60a	1.25	2.50	18	12A	1.95,	25a	1.95	3.90
10	20A	1.20,	40a	1.20	2.40	*24	10A	2.65,	20a	2.65	5.30
12	15A	1.15,	30a	1.10	2.25	*30	9A	3.35,	18a	3.30	6.65
14	15A	1.30,	30a	1.25	2.55	36	8A	4.75,	15a	4.70	9.45
18	12A	1.60,	25a	1.60	3.20	GOTHIC NO. 205				144	
FANCY TEXT NO. 515				294	GOTHIC NO. 206				145, 146		
24 Pt.	7A	\$2.75,	20a	\$1.50	\$4.25	6 Pt.	30A	\$1.50,	30a	\$0.95	\$2.45
36	6A	4.00,	15a	2.35	6.35	8	25A	1.70,	25a	1.00	2.70
48	5A	5.00,	12a	3.45	8.45						
FIGURES, ALL KINDS.				7							
FLORENCE NO. 1568				277							
12 Pt.	15A	\$1.50,	15a	\$0.95	\$2.45						
18	12A	2.10,	12a	1.25	3.35						
24	10A	2.50,	10a	1.55	4.05						
30	8A	3.05,	8a	2.00	5.05						
36	6A	3.00,	6a	1.75	5.75						
48	5A	4.00,	5a	2.30	6.30						
FLORENTINE HEAVYFACE				208 M							
5 on 6 Pt.	24A	\$1.25,	36a	\$1.25	\$2.50						
6	24A	1.40,	36a	1.10	2.50						
8	22A	1.50,	30a	1.25	2.75						
10	20A	1.65,	26a	1.35	3.00						
12	16A	1.85,	20a	1.40	3.25						
18	10A	2.10,	16a	1.90	4.00						
24	8A	2.55,	10a	1.95	4.50						
36	5A	2.85,	8a	2.65	5.50						
48	4A	4.25,	5a	3.50	7.75						
GERMAN NO. 90				82-88							
GERMAN NO. 91				89-91							
GERMAN CONDENSED NO. 491				94-96							
6 Pt.	20A	\$1.40,	60a	\$1.35	\$2.75						
8	20A	1.85,	60a	1.75	3.60						
10	10A	1.15,	30a	1.05	2.20						
12	10A	1.40,	30a	1.30	2.70						
14	10A	1.70,	30a	1.55	3.25						
18	8A	2.00,	25a	1.70	3.70						
*24	8A	2.85,	25a	2.45	5.30						
*30	7A	3.75,	20a	3.25	7.00						
36	6A	4.45,	15a	3.90	8.35						
*42	5A	4.20,	10a	3.50	7.70						
48	5A	6.25,	10a	5.35	11.60						

* Fonts either changed in body or scheme.

				PAGE
GOTHIC NO. 208...CONTINUED 145, 148				
10.....	20A	\$1.70,	20a \$1.00	\$2.70
12.....	15A	1.50,	15a 1.00	2.55
18.....	12A	2.20,	12a 1.40	3.60
24.....	10A	2.50,	10a 1.55	4.05
30.....	8A	3.65,	8a 2.00	5.65
36.....	6A	4.00,	6a 2.45	6.45
48.....	5A	5.50,	5a 3.00	8.50
GOTHIC ALIGNED, HEAVY 135				
6 Pt. No. 1.....	50A			\$1.40
6 Pt. No. 2.....	50A			1.50
6 Pt. No. 3.....	50A			1.75
6 Pt. No. 4.....	50A			2.20
6 Pt. No. 5.....	50A			2.60
GOTHIC ALIGNED, LIGHT 136				
6 Pt. No. 6.....	50A			\$1.00
6 Pt. No. 7.....	50A			1.15
6 Pt. No. 8.....	50A			1.45
6 Pt. No. 9.....	50A			1.90
GOTHIC CONDENSED NO. 240 148, 149				
6 Pt.....	30A	\$1.00,	60a \$1.05	\$2.05
8.....	30A	1.30,	60a 1.40	2.70
10.....	20A	1.15,	40a 1.25	2.40
12.....	15A	1.15,	30a 1.25	2.40
18.....	12A	1.60,	25a 1.70	3.30
*24.....	10A	1.80,	20a 2.20	4.00
*30.....	8A	2.30,	16a 2.70	5.00
*36.....	7A	3.00,	12a 3.60	6.60
*48.....	6A	3.90,	10a 4.60	8.50
*54.....	5A	3.50,	5a 3.00	6.50
GOTHIC CONDENSED NO. 241 150, 151				
6 Pt.....	30A	\$1.10,	60a \$1.20	\$2.30
8.....	30A	1.30,	60a 1.40	2.70
10.....	20A	1.20,	40a 1.30	2.50
12.....	15A	1.00,	30a 1.15	2.15
18.....	12A	1.60,	25a 1.70	3.30
*24.....	12A	2.00,	25a 2.20	4.20
*30.....	10A	2.50,	20a 2.70	5.20
36.....	8A	3.35,	15a 3.50	6.85
GOTHIC CONDENSED NO. 242 152, 153				
8 Pt.....	30A			\$1.25
10.....	20A			1.00
12.....	15A			1.00
16.....	15A			1.50
20.....	12A	\$2.40,	25a \$1.40	3.80
24.....	10A	3.00,	20a 1.85	4.85
36.....	8A	4.85,	15a 3.00	7.85
48.....	5A	3.70,	5a 3.00	6.70
72.....	5A	11.00,	5a 8.00	19.00
GOTHIC CONDENSED NO. 243 154, 155				
5 Pt.....	30A			\$1.15
6.....	30A			1.15
8.....	30A			1.55
10.....	20A			1.30
12.....	15A			1.15
18.....	12A			1.75
24.....	10A			2.45
36.....	8A			4.20
48.....	5A			4.75
GOTHIC CONDENSED NO. 244 156				
6 Pt.....	30A			\$0.90
8.....	30A			1.15
10.....	20A			1.00
12.....	15A			1.00
16.....	15A			1.35
20.....	12A			1.90
24.....	10A			2.30
36.....	8A			3.80
GOTHIC CONDENSED HAIRLINE NO. 621 158				
5 Pt.....	30A			\$1.40
6.....	30A			1.50
8.....	30A			2.00
10.....	20A			1.95
12.....	15A			1.75

				PAGE
GOTHIC CONDENSED ITALIC NO. 260 161				
8 Pt.....	30A	\$1.75,	60a \$1.40	\$3.15
10.....	20A	1.50,	40a 1.10	2.60
12.....	15A	1.50,	30a 1.15	2.65
*18.....	12A	1.90,	25a 1.55	3.45
*24.....	10A	2.60,	20a 2.00	4.60
GOTHIC CONDENSED ITALIC NO. 261 162				
48 Pt.....	5A			\$6.10
72.....	5A			10.55
GOTHIC EXTENDED NO. 250 159				
6 Pt.....	30A	\$1.50,	30a \$0.80	\$2.30
8.....	30A	2.00,	30a .95	2.95
10.....	20A	1.65,	20a .85	2.50
12.....	15A	1.65,	15a .85	2.50
18.....	12A	2.50,	12a 1.30	3.80
24.....	10A	3.70,	10a 2.00	5.70
36.....	8A	5.90,	8a 3.25	9.15
48.....	5A	6.20,	5a 3.40	9.60
GOTHIC EXTRA CONDENSED NO. 620 157				
12 Pt.....	15A	\$1.10,	30a \$1.10	\$2.20
18.....	12A	1.60,	25a 1.50	3.10
24.....	10A	1.90,	20a 1.80	3.70
36.....	8A	3.00,	15a 2.75	5.75
48.....	7A	4.55,	12a 4.00	8.55
GOTHIC ITALIC NO. 208 146				
10 Pt.....	20A	\$1.80,	20a \$1.00	\$2.80
12.....	15A	1.65,	15a 1.00	2.65
30.....	8A	3.50,	8a 2.50	6.00
GREEKIAN NO. 633 187, 188				
18 Pt.....	12A			\$1.50
24.....	10A			2.25
36.....	8A			4.10
48.....	5A			3.80
60.....	5A			6.90
84.....	4A			8.70
120.....	4A			14.30
144.....	3A			14.55
HAIRLINE SHADED NO. 648 316				
12 Pt.....	15A	\$1.85,	30a \$1.80	\$3.65
HARRINGTON NO. 1525 248				
12 Pt.....	15A	\$2.10,	30a \$1.95	\$4.05
18.....	12A	3.20,	25a 2.90	6.10
24.....	10A	4.00,	20a 3.65	7.65
36.....	8A	7.00,	15a 5.90	12.90
48.....	5A	5.55,	5a 4.60	10.15
HEAD AND TAIL PIECES 438, 440				
IMPERIAL ITALIC NO. 1546 265				
12 Pt.....	15A	\$2.00,	30a \$1.50	\$3.50
18.....	12A	3.00,	25a 2.00	5.00
24.....	10A	4.00,	20a 2.85	6.85
36.....	6A	5.00,	10a 3.50	8.50
48.....	5A	6.00,	5a 3.35	9.35
INDEX CUTS 445				
INITIAL NO. 1505 237				
22 Pt.....	12A	\$3.30,	25a \$2.90	\$6.20
28.....	10A	4.00,	20a 3.20	7.20
36.....	8A	5.50,	15a 4.55	10.05
INITIALS, ELECTROTYPE 402, 403				
ITALIAN ANTIQUE NO. 308 172				
6 Pt.....	30A	\$1.60,	60a \$1.60	\$3.20
8.....	30A	2.00,	60a 1.95	3.95
10.....	20A	1.65,	40a 1.60	3.25
12.....	15A	1.80,	30a 1.75	3.55
18.....	12A	2.60,	25a 2.60	5.20
24.....	10A	3.80,	20a 3.75	7.55
36.....	8A	6.25,	15a 6.20	12.45
48.....	5A	6.35,	5a 4.30	10.65
ITALIAN BLACK ORNAMENTED NO. 525 301				
18 Pt.....	8A	\$4.75,	25a \$3.00	\$7.75
24.....	7A	6.00,	20a 4.10	10.10
36.....	6A	8.25,	15a 6.00	14.25

* Fonts either changed in body or scheme.

				PAGE					PAGE	
ITALIAN CONDENSED NO. 341				189, 190	LACLEDE SERIES..CONTINUED				320 L	
6 Pt.	30A	\$1.00,	60a	\$0.90	48	4A	\$4.50,	7a	\$3.50	\$8.00
8	30A	1.35,	60a	1.25	60	3A	5.50,	6a	4.50	10.00
10	20A	1.20,	40a	1.10	72	3A	7.50,	5a	4.50	12.00
12	15A	1.40,	30a	1.25						
18	12A	1.65,	25a	1.45						
*24	10A	3.00,	20a	2.50						
*30	9A	3.15,	18a	2.75						
36	8A	4.60,	15a	4.20						
48	7A	5.75,	12a	5.20						
ITALIAN SCRIPT NO. 2007				335	LAW ITALIC NO. 146				119	
*30 Pt. Card Font.	4A	\$2.85,	9a	\$1.40	8 Pt.	30A	1.90,	60a	1.80	3.70
*30 " Circular "	7A	6.00,	50a	9.35	10	20A	1.70,	40a	1.65	3.35
ITALIAN SCRIPT NO. 2011				337	12	15A	1.50,	30a	1.45	2.95
*24 Pt. Card Font.	4A	\$2.00,	10a	\$1.75						
*36 " " " "	4A	3.60,	10a	2.40						
*48 " " " "	4A	4.50,	8a	3.00						
*24 " Circular "	7A	2.70,	60a	9.90						
36 " " " "	7A	5.25,	20a	5.40						
*48 " " " "	5A	5.75,	12a	5.65						
ITALIAN TEXT NO. 522				299	LIGHT HARRINGTON NO. 1526				249	
18 Pt.	10A	\$1.75,	30a	\$2.75	12 Pt.	15A	\$2.20,	30a	\$1.40	\$3.60
28	7A	3.30,	20a	3.50	18	12A	3.40,	25a	2.00	5.40
ITALIC FIGURES				7	24	10A	4.20,	20a	3.00	7.20
ITALIC HAIRLINE NO. 645				316	36	8A	6.00,	15a	4.65	10.65
10 Pt.	20A	\$2.55,	40a	\$2.50	48	5A	5.55,	5a	4.00	9.55
12	15A	2.70,	30a	2.65						
ITALIC HAIRLINE NO. 649				119	LITHOGRAPHIC BLACK NO. 534				305	
18 Pt.	12A	\$2.75,	25a	\$2.00	12 Pt.	10A	\$1.80,	30a	\$2.25	\$4.05
JENSEN HEAVYFACE				240 M-P	18	8A	3.50,	25a	2.40	5.90
12 Pt.	18A	\$1.85,	30a	\$1.40	24	7A	3.65,	20a	4.90	8.55
18	12A	2.30,	20a	1.70	36	6A	5.00,	15a	6.25	11.25
24	10A	2.70,	15a	1.80						
30	6A	2.75,	10a	2.25						
36	5A	3.20,	8a	2.30						
48	4A	5.00,	5a	2.75						
60	4A	7.85,	5a	4.40						
72	4A	11.00,	5a	6.00						
96	3A	12.50,	4a	6.50						
120	3A	14.80,	4a	7.70						
JENSEN ITALIC				240 G-L	LIVERMORE SERIES				320 M	
6 Pt.	20A	\$1.20,	50a	\$1.30	6 Pt.	15A	\$1.00,	60a	\$1.50	\$2.50
8	20A	1.40,	50a	1.35	8	15A	1.15,	55a	1.60	2.75
10	20A	1.60,	45a	1.40	10	15A	1.25,	55a	1.75	3.00
12	18A	1.70,	40a	1.55	12	15A	1.40,	50a	1.85	3.25
18	10A	2.00,	25a	2.00	18	9A	1.70,	28a	2.05	3.75
24	6A	2.15,	15a	2.35	24	6A	1.95,	18a	2.30	4.25
30	5A	2.40,	10a	2.60	30	5A	2.40,	12a	2.35	4.75
36	4A	2.80,	8a	2.70	36	4A	2.60,	10a	2.65	5.25
42	4A	4.00,	6a	3.25	48	3A	3.40,	6a	2.85	6.25
48	4A	4.50,	5a	3.25	60	3A	5.55,	4a	2.70	8.25
54	4A	6.00,	5a	4.25						
60	4A	8.00,	5a	4.25						
72	4A	9.00,	5a	8.00						
JENSEN OLD STYLE				240 A-F	MADISONIAN NO. 652				317	
6 Pt.	35A	\$1.50,	50a	\$1.00	10 Pt.	14A	\$2.90,	40a	\$2.60	\$5.50
8	25A	1.50,	35a	1.25	12	10A	2.65,	30a	2.30	4.95
10	25A	1.75,	30a	1.25	18	8A	3.40,	25a	2.85	6.25
12	18A	1.85,	30a	1.40	*24	7A	4.60,	20a	3.90	8.50
14	15A	1.95,	25a	1.55	*36	6A	7.00,	15a	5.50	12.50
18	12A	2.20,	20a	1.80	*48	5A	8.50,	12a	6.50	15.00
24	10A	2.60,	15a	1.90						
30	6A	2.90,	10a	2.10						
36	5A	3.00,	8a	2.50						
42	4A	4.00,	6a	3.25						
48	4A	4.65,	5a	3.10						
54	4A	6.00,	5a	4.25						
60	4A	7.25,	5a	5.00						
72	4A	10.00,	5a	7.00						
LACLEDE SERIES				320 L	MALTESE CROSSES				404	
10 Pt.	9A	\$1.15,	30a	\$1.60	MANHATTAN NO. 1570				278	
12	7A	1.15,	24a	1.85	*12 Pt.	10A	\$1.85,	15a	\$1.15	\$3.00
18	5A	1.25,	18a	2.00	*18	8A	2.50,	12a	1.50	4.00
24	5A	1.85,	14a	2.15	*24	6A	3.00,	10a	2.00	5.00
36	4A	3.25,	9a	3.00	*30	5A	3.75,	8a	2.25	6.00
					*36	4A	4.50,	6a	2.50	7.00
					*48	4A	5.00,	5a	3.00	8.00
					MATHEMATICAL SIGNS				12	
					MEDIEVAL NO. 524				307	
					24 Pt.	7A	\$2.70,	7a	\$2.50	[\$5.20]
					METAL BRACES				10	
					METAL CORNER QUADS				12	
					MISCELLANEOUS CUTS, CAST				409-411	
					MISCELLANEOUS CUTS, ELECTROTYPE				406	
					MODERN TEXT NO. 510				283, 291	
					84 Pt.	3A	\$10.00,	5a	\$6.70	\$16.70
					96	3A	11.40,	5a	7.00	18.40
					120	3A	16.00,	5a	10.70	26.70
					MODERN TEXT NO. 511				290	
					84 Pt.	3A	\$10.00,	5a	\$6.70	\$16.70
					96	3A	11.00,	5a	7.40	18.40
					120	3A	16.00,	5a	10.70	26.70
					MONASTERY TEXT NO. 401				282, 283	
					*8 Pt.	15A	\$1.80,	45a	\$1.70	\$3.50
					*10	10A	1.75,	30a	1.50	3.25
					*12	8A	1.80,	25a	1.70	3.50
					*14	8A	2.00,	25a	2.00	4.00
					*18	7A	2.75,	20a	2.25	5.00
					*24	6A	3.50,	18a	3.00	6.50
					*72	3A	7.00,	5a	5.80	12.80
					MONOGRAM NO. 530				302	
					24 Pt.	7A	\$2.85,	20A	\$2.00	\$4.85
					36	6A	3.65,	15A	3.00	6.65
					48	5A	5.00,	12A	4.25	9.25

* Fonts either changed in body or scheme.

				PAGE
MONOGRAM NO. 531				302
24 Pt.	7A	\$2.85,	20A \$2.00	\$4.85
36	6A	3.75,	15A 3.00	6.75
48	5A	5.00,	12A 4.85	9.35
MURRAY ANTIQUE NO. 311				175
10 Pt.	20A	\$1.75,	40a \$1.75	\$3.50
12	15A	1.65,	30a 1.65	3.30
18	12A	2.55,	25a 2.55	5.10
24	10A	3.35,	20a 3.35	6.70
36	8A	3.90,	15a 3.80	7.70
48	5A	5.00,	5a 3.90	8.90
MANANT TEXT NO. 544				312
12 Pt.	10A	\$2.05,	30a \$2.00	\$4.05
18	8A	2.75,	25a 2.50	5.25
24	7A	3.70,	20a 3.50	7.20
36	6A	5.00,	15a 4.85	9.85
48	5A	6.00,	5a 3.70	9.70
NEWSPAPER READINGS				446-448
NOTARIAL SCRIPT				336
*30 Pt. Card Font	5A	\$2.50,	12a \$1.50	\$4.00
*30 "Circular"	7A	4.05,	55a 8.00	12.05
OLD STYLE ANTIQUE NO. 310				174
6 Pt.	30A	\$1.35,	60a \$1.25	\$2.60
8	30A	1.75,	60a 1.50	3.25
10	20A	1.50,	40a 1.30	2.80
12	15A	1.40,	30a 1.25	2.65
18	12A	2.40,	25a 2.00	4.40
*24	10A	3.40,	20a 2.75	6.15
*30	9A	4.85,	18a 3.00	7.85
36	6A	5.00,	12a 3.60	8.60
ORNAMENTED NO. 1009				206
12 Pt.	15A			\$2.60
18	12A			3.40
22	12A			4.70
28	10A			6.00
36	8A			6.95
48	5A			8.10
60	5A			10.90
ORNAMENTED NO. 1024				207
12 Pt.	15A			\$2.30
18	12A			3.50
24	10A			4.95
36	8A			7.80
48	5A			7.40
ORNAMENTED NO. 1025				208
12 Pt.	15A			\$1.90
18	12A			3.00
24	10A			4.25
36	8A			6.65
48	5A			7.00
72	5A			10.25
ORNAMENTED NO. 1029				209
12 Pt.	15A			\$2.30
18	12A			3.00
22	12A			4.50
28	10A			6.25
36	8A			6.85
48	5A			7.85
ORNAMENTED NO. 1031				210
20 Pt.	12A			\$4.70
24	10A			6.65
28	10A			6.90
36	8A			8.30
ORNAMENTED NO. 1050				218
12 Pt.	15A			\$1.60
18	12A			2.40
24	10A			3.15
36	8A			5.75
48	5A			4.75
ORNAMENTED NO. 1051				214
12 Pt.	15A			\$2.15
18	12A			3.25
24	10A			4.85
36	8A			9.10
48	5A			8.45

				PAGE
ORNAMENTED NO. 1060				217
12 Pt.	15A			\$3.35
18	12A			4.00
24	10A			5.85
36	8A			10.65
48	5A			7.85
ORNAMENTED NO. 1066				202
10 Pt.	20A			\$2.75
12	15A			2.60
18	12A			3.50
24	10A			4.95
36	8A			7.40
ORNAMENTED NO. 1068				219
10 Pt.	20A			\$2.10
12	15A			2.20
18	12A			2.85
24	10A			4.05
36	8A			8.00
48	5A			6.85
ORNAMENTED NO. 1071				220
12 Pt.	15A			\$2.75
18	12A			4.25
24	10A			5.75
36	8A			11.50
ORNAMENTED NO. 1074				222
18 Pt.	12A			\$2.25
24	10A			3.40
36	8A			5.00
48	5A			5.75
ORNAMENTED NO. 1075				228
12 Pt.	15A			\$2.30
18	12A			3.35
24	10A			4.40
36	8A			8.20
ORNAMENTED NO. 1080				227
12 Pt.	15A			\$1.60
18	12A			2.35
24	10A			3.05
36	8A			5.65
48	5A			5.20
ORNAMENTED NO. 1081				228
12 Pt.	15A			\$1.60
18	12A			2.00
24	10A			2.35
36	8A			5.75
48	5A			5.30
ORNAMENTED NO. 1082				229
12 Pt.	15A			\$1.75
18	12A			2.35
24	10A			3.15
36	8A			5.75
ORNAMENTED NO. 1506				238
12 Pt.	15A	\$1.80,	30a \$1.70	\$3.50
18	12A	2.40,	25a 2.35	4.75
24	10A	3.20,	20a 3.10	6.30
ORNAMENTED NO. 1507				238
12 Pt.	15A	\$2.20,	30a \$2.15	4.35
18	12A	3.25,	25a 3.25	6.50
24	10A	4.10,	20a 4.10	8.20
ORNAMENTED NO. 1508				239
6 Pt.	30A			\$2.00
10	20A	\$3.30,	40a \$2.25	4.55
12	15A	2.50,	30a 2.45	4.95
20	12A	3.75,	25a 3.75	7.50
24	10A	4.75,	20a 4.70	9.45
ORNAMENTED NO. 1512				242
6 Pt.	30A	\$2.25,	60a \$2.25	\$4.50
8	30A	3.00,	60a 3.00	6.00
12	15A	2.35,	30a 2.30	4.65
18	12A	3.15,	25a 3.10	6.25
24	10A	4.65,	20a 4.60	9.25

* Fonts either changed in body or scheme.

				PAGE					PAGE		
ORNAMENTED NO. 1513				243	ORNAMENTED NO. 1542				262		
12 Pt.	15A	\$2.55,	15a	\$1.50	\$4.05	12 Pt.	15A	\$3.50,	15a	\$3.10	\$3.60
20.	12A	4.00,	12a	2.60	6.60	18.	12A	2.80,	12a	2.30	5.10
24.	10A	5.00,	10a	3.20	8.20	24.	10A	4.00,	10a	3.55	7.55
36.	8A	8.95,	8a	6.00	14.95	36.	8A	7.00,	8a	6.35	13.35
48.	5A	8.75,	5a	6.00	14.75	48.	5A	7.50,	5a	6.20	13.70
ORNAMENTED NO. 1515				245	ORNAMENTED NO. 1543				263		
10 Pt.	20A	\$3.35,	20a	\$2.00	\$5.35	12 Pt.	15A	\$1.65,	30a	\$1.55	\$3.20
12.	15A	3.35,	15a	2.00	5.35	18.	12A	2.25,	25a	2.00	4.25
18.	12A	4.25,	12a	2.75	7.00	24.	10A	3.40,	20a	3.00	6.40
24.	10A	6.15,	10a	4.00	10.15	36.	8A	5.35,	15a	4.75	10.10
36.	8A	10.00,	8a	6.70	16.70	48.	5A	4.50,	5a	3.80	8.30
48.	5A	10.30,	5a	7.00	17.30	ORNAMENTED NO. 1545				264	
ORNAMENTED NO. 1519				246	ORNAMENTED NO. 1547				266		
12 Pt.	15A	\$2.75,	15a	\$1.85	\$4.65	12 Pt.	15A	\$2.15,	30a	\$1.90	\$4.05
18.	12A	4.00,	12a	2.50	6.50	18.	12A	3.00,	25a	2.60	5.60
24.	10A	5.50,	10a	3.50	9.00	24.	10A	3.30,	10a	2.75	6.05
36.	8A	10.00,	8a	6.20	16.20	36.	8A	5.15,	8a	4.50	9.65
ORNAMENTED NO. 1522				247	ORNAMENTED NO. 1549				205		
12 Pt.	15A	\$4.00,	15a	\$2.95	\$6.95	18 Pt.	12A	\$2.00,	25a	\$1.85	\$3.85
18.	10A	5.75,	10a	4.00	9.75	24.	10A	3.00,	20a	2.65	5.65
24.	6A	5.65,	6a	3.90	9.55	36.	8A	4.60,	15a	4.00	8.60
36.	4A	8.00,	4a	5.10	13.10	ORNAMENTED ITALIC NO. 1550				205	
ORNAMENTED NO. 1528				251	ORNAMENTED NO. 1549				205		
12 Pt.	15A	\$2.35,	30a	\$2.00	\$4.35	12 Pt.	15A	\$2.50,	30a	\$2.15	\$4.65
18.	12A	3.00,	25a	2.75	5.75	18.	12A	3.80,	25a	3.35	7.15
24.	10A	4.50,	20a	3.95	8.45	24.	10A	5.35,	20a	4.65	10.00
36.	8A	7.75,	15a	6.00	13.75	ORNAMENTS, ELECTROTYPE				437	
48.	5A	6.00,	5a	4.60	10.60	OUTLINE NO. 646				196	
ORNAMENTED NO. 1529				252	ORNAMENTED NO. 1531				254		
18 Pt.	12A	\$2.50,	25a	\$2.00	\$4.50	18 Pt.	12A	\$2.65,	25a	\$2.25	\$4.90
24.	10A	3.50,	20a	2.70	6.20	24.	10A	3.75,	20a	3.00	6.75
36.	8A	5.75,	15a	4.50	10.25	36.	8A	6.50,	15a	5.00	11.50
48.	5A	4.95,	5a	3.50	8.45	48.	7A	9.90,	12a	7.00	16.90
ORNAMENTED NO. 1530				253	ORNAMENTED NO. 1532				255		
24 Pt.	10A	\$3.30,	10a	\$3.00	\$6.30	18 Pt.	12A	\$3.00,	25a	\$2.60	\$5.60
36.	8A	6.00,	8a	3.45	9.45	24.	10A	4.50,	20a	3.60	8.10
48.	5A	6.35,	5a	5.00	11.35	36.	8A	7.00,	15a	5.90	12.90
ORNAMENTED NO. 1531				254	ORNAMENTED NO. 1533				256		
18 Pt.	12A	\$2.65,	25a	\$2.25	\$4.90	18 Pt.	15A	\$2.25,	15a	\$2.00	\$4.25
24.	10A	3.75,	20a	3.00	6.75	24.	10A	2.70,	10a	2.35	5.05
36.	8A	6.50,	15a	5.00	11.50	36.	8A	5.00,	8a	4.00	9.00
48.	7A	9.90,	12a	7.00	16.90	48.	5A	5.00,	5a	4.00	9.00
ORNAMENTED NO. 1532				255	ORNAMENTED NO. 1535				257		
18 Pt.	12A	\$3.00,	25a	\$2.60	\$5.60	20 Pt.	12A	\$2.80,	25a	\$2.25	\$5.05
24.	10A	4.50,	20a	3.60	8.10	ORNAMENTED NO. 1536				258	
36.	8A	7.00,	15a	5.90	12.90	10 Pt.	20A	\$2.20,	40a	\$2.00	\$4.20
48.	7A	10.00,	12a	8.00	18.00	12.	15A	2.30,	30a	2.05	4.35
ORNAMENTED NO. 1533				256	ORNAMENTED NO. 1537				203		
18 Pt.	15A	\$2.25,	15a	\$2.00	\$4.25	10 Pt.	20A	\$2.20,	40a	\$2.20	\$4.40
24.	10A	2.70,	10a	2.35	5.05	12.	15A	2.50,	30a	2.15	4.65
36.	8A	5.00,	8a	4.00	9.00	18.	12A	3.15,	25a	2.75	5.90
48.	5A	5.00,	5a	4.00	9.00	22.	12A	4.00,	25a	3.75	7.75
ORNAMENTED NO. 1535				257	ORNAMENTED NO. 1540				199, 200		
20 Pt.	12A	\$2.80,	25a	\$2.25	\$5.05	6 Pt.	30A	\$2.75,			
ORNAMENTED NO. 1536				258	ORNAMENTED NO. 1548				267		
10 Pt.	20A	\$2.20,	40a	\$2.00	\$4.20	18 Pt.	12A	\$2.30,	12a	\$1.80	\$4.10
12.	15A	2.30,	30a	2.05	4.35	24.	10A	3.50,	10a	2.25	5.75
18.	12A	2.85,	25a	2.50	5.35	36.	8A	4.75,	8a	3.85	8.60
24.	10A	3.50,	20a	2.80	6.30	48.	5A	4.85,	5a	3.90	8.75
36.	8A	5.75,	15a	4.40	10.15	ORNAMENTED NO. 1564				204	
ORNAMENTED NO. 1537				203	ORNAMENTED NO. 1542				262		
10 Pt.	20A	\$2.20,	40a	\$2.20	\$4.40	12 Pt.	15A	\$3.50,	15a	\$3.10	\$3.60
12.	15A	2.50,	30a	2.15	4.65	18.	12A	2.80,	12a	2.30	5.10
18.	12A	3.15,	25a	2.75	5.90	24.	10A	4.00,	10a	3.55	7.55
22.	12A	4.00,	25a	3.75	7.75	36.	8A	7.00,	8a	6.35	13.35
28.	10A	5.00,	20a	4.55	9.55	48.	5A	7.50,	5a	6.20	13.70
36.	8A	7.00,	15a	6.25	13.25	ORNAMENTED NO. 1543				263	
ORNAMENTED NO. 1540				260	ORNAMENTED NO. 1545				264		
12 Pt.	15A	\$1.70,	15a	\$1.50	\$3.20	12 Pt.	15A	\$1.85,	30a	\$1.65	\$3.50
18.	12A	2.25,	12a	2.00	4.25	18.	12A	2.70,	25a	2.20	4.90
24.	10A	3.30,	10a	3.00	6.30	24.	10A	3.80,	20a	3.15	6.95
36.	8A	5.65,	8a	5.00	10.65	36.	8A	6.20,	15a	5.50	11.70
48.	5A	6.50,	5a	5.20	11.70	48.	5A	5.30,	5a	4.25	9.55
					ORNAMENTED NO. 1547				266		
					ORNAMENTED NO. 1549				205		
					ORNAMENTED ITALIC NO. 1550				205		
					ORNAMENTS, ELECTROTYPE				437		
					OUTLINE NO. 646				196		
					OUTLINE NO. 1010				197, 198		
					OUTLINE NO. 1037				201		
					OUTLINE NO. 1040				199, 200		
					OUTLINE NO. 1048				267		
					OUTLINE NO. 1564				204		

* Fonts either changed in body or scheme.

				PAGE
PAINT BRUSH NO. 651				
12 Pt.	15A	\$2.60,	30a \$2.50	\$5.10
18	12A	3.35,	25a 3.00	6.35
22	12A	4.75,	25a 4.00	8.75
PARKER TITLE NO. 1514				
12 Pt.	15A	\$2.65,	15a \$2.00	\$4.65
*18	12A	4.00,	12a 3.50	7.50
*24	10A	4.60,	10a 3.90	8.50
*30	8A			8.70
*36	6A			8.00
PENMAN SCRIPT NO. 2051				
*12 Pt. Card Font	5A	\$1.40,	18a \$1.40	\$2.80
*16	4A	1.75,	12a 1.50	3.25
*20	4A	2.00,	10a 1.75	3.75
*24	4A	2.50,	9a 2.00	4.50
*36	3A	4.00,	8a 3.00	7.00
12	15A	6.00,	60a 4.15	10.15
16	12A	7.00,	50a 5.20	12.20
20	10A	8.00,	40a 5.40	13.40
24	7A	8.50,	30a 6.25	14.75
*36	6A	10.50,	20a 5.80	16.30
PENMAN SCRIPT NO. 2052				
*20 Pt. Card Font	4A	\$2.00,	10a \$1.75	\$3.75
*24	4A	2.75,	9a 1.75	4.50
*36	3A	4.50,	8a 2.50	7.00
20	10A	7.75,	40a 4.60	12.35
24	7A	8.50,	30a 5.10	13.60
*36	6A	10.50,	20a 4.65	15.15
PENMAN SCRIPT NO. 2053				
*12 Pt. Card Font	5A	\$1.40,	18a \$1.40	\$2.80
*16	4A	1.70,	12a 1.55	3.25
*20	4A	2.00,	10a 1.75	3.75
*24	4A	2.50,	9a 2.00	4.50
*36	3A	4.25,	8a 2.75	7.00
*48	3A	7.00,	6a 3.50	10.50
12	15A	6.00,	60a 4.00	10.00
16	12A	7.00,	50a 5.30	12.30
20	10A	8.00,	40a 5.15	13.15
24	7A	9.50,	30a 4.65	14.15
*36	6A	10.50,	20a 5.10	15.60
*48	6A	11.50,	12a 6.65	18.15
60	3A	10.00,	8a 5.85	15.85
84	3A	17.00,	8a 9.70	26.70
PENMAN SCRIPT NO. 2054				
*48 Pt. Card Font	3A	\$6.75,	6a \$3.75	\$10.50
*48	6A	11.50,	12a 6.85	18.45
60	3A	10.00,	8a 5.20	15.20
84	3A	17.00,	8a 8.20	25.20
PER CENT MARKS				
PIECE ACCENTS				
PIECE FRACTIONS				
PITKIN NO. 1538				
8 Pt.	30A	\$2.00,	60a \$2.00	\$4.00
10	20A	1.70,	40a 1.70	3.40
12	15A	1.60,	30a 1.60	3.20
18	12A	2.40,	25a 2.35	4.75
24	10A	3.05,	20a 3.00	6.05
36	8A	5.00,	15a 4.75	9.75
POINTED FIGURES				
POINTED GOTHIC NO. 1511				
12 Pt.	15A	\$1.25,	30a \$1.20	\$2.45
20	12A	1.70,	25a 1.70	3.40
24	10A	2.00,	20a 1.95	3.95
36	8A	3.30,	15a 3.25	6.55
POINTERS NO. 1				
POINTERS NO. 2				
POST OLD STYLE ITALIC				
6 Pt.	16A	\$0.90,	36a \$1.10	\$2.00
8	14A	1.00,	32a 1.25	2.25
10	14A	1.10,	32a 1.40	2.50
12	10A	1.05,	25a 1.45	2.50
14	9A	1.25,	20a 1.50	2.75
18	7A	1.30,	16a 1.70	3.00

				PAGE
POST OLD STYLE ITALIC..CONTINUED				
24	5A	\$1.60,	12a \$2.15	\$3.75
30	4A	1.95,	9a 2.30	4.25
36	3A	2.50,	6a 2.25	4.75
48	3A	4.25,	5a 3.00	7.25
60	3A	6.40,	4a 4.10	10.50
POST OLD STYLE NO. 1				
6 Pt.	16A	\$0.95,	25a \$1.05	\$2.00
8	16A	1.15,	24a 1.10	2.25
10	14A	1.35,	20a 1.15	2.50
12	14A	1.45,	20a 1.30	2.75
14	12A	1.55,	18a 1.45	3.00
18	8A	1.65,	12a 1.60	3.25
24	6A	2.05,	9a 1.70	3.75
30	4A	2.25,	6a 2.00	4.25
36	3A	3.05,	5a 2.45	5.50
42	3A	4.20,	4a 2.80	7.00
48	3A	5.05,	4a 3.45	8.50
54	3A	6.50,	4a 4.25	10.75
60	3A	7.00,	4a 4.50	11.50
72	3A	12.00,	4a 7.00	19.00
POST OLD STYLE NO. 2				
6 Pt.	15A	\$0.90,	24a \$1.10	\$2.00
8	14A	1.10,	20a 1.15	2.25
10	12A	1.25,	18a 1.25	2.50
12	12A	1.35,	18a 1.40	2.75
14	10A	1.45,	15a 1.55	3.00
18	7A	1.50,	10a 1.75	3.25
24	5A	1.75,	8a 1.75	3.50
30	4A	2.25,	6a 2.25	4.50
36	3A	3.10,	5a 2.65	5.75
42	3A	4.20,	4a 3.30	7.50
48	3A	5.30,	4a 4.20	9.50
54	3A	6.50,	4a 4.75	11.25
60	3A	7.00,	4a 6.00	13.00
72	3A	11.65,	4a 8.35	20.00
POST ORNAMENTS AND INITIALS				
PROGRAM NO. 1534				
6 Pt.	30A	\$1.85,	60A \$1.40	\$3.25
QUENTELL SERIES				
6 Pt.	24A	\$1.10,	36a \$1.15	\$2.25
8	22A	1.30,	30a 1.20	2.50
10	20A	1.50,	26a 1.25	2.75
12	16A	1.65,	20a 1.35	3.00
14	12A	1.65,	18a 1.60	3.25
18	10A	1.60,	16a 1.65	3.25
24	8A	2.30,	10a 1.70	4.00
30	6A	2.70,	9a 2.30	5.00
36	5A	3.00,	8a 2.50	5.50
42	4A	3.75,	6a 3.50	7.25
48	4A	4.65,	5a 3.10	7.75
54	4A	6.00,	5a 4.25	10.25
60	4A	7.25,	5a 5.00	12.25
72	4A	10.00,	5a 7.00	17.00
RALSTON NO. 1089				
12 Pt.	15A			\$1.15
18	12A			1.35
24	10A			1.80
36	8A			2.55
48	5A			2.70
RAY SHADED NO. 529				
24 Pt.	6A	\$3.85,	15a \$3.80	\$7.65
36	4A	4.75,	10a 4.70	9.45
RECIPE MARKS				
REGAL ITALIC				
6 Pt.	24A	\$1.25,	48a \$1.25	\$2.50
8	18A	1.50,	36a 1.50	3.00
10	14A	1.75,	28a 1.75	3.50
12	12A	2.00,	24a 2.00	4.00
14	9A	2.00,	18a 2.20	4.20
18	7A	2.25,	14a 2.25	4.50
24	6A	2.50,	12a 2.75	5.25
30	5A	2.80,	10a 3.20	6.00
36	4A	3.25,	6a 3.25	6.50

* Fonts either changed in body or scheme.

				PAGE
REGAL TEXT NO. 543				311
12 Pt.	10A	\$1.75,	30a \$1.75	\$3.50
18.	8A	2.15,	25a 2.10	4.25
24.	7A	3.20,	20a 3.00	6.20
36.	6A	4.50,	15a 4.30	8.80
RELIGIOUS CUTS				444
REMINGTON STANDARD				320 0
12 Pt.	20A	\$2.00,	110a \$5.25	\$7.25
ROMAN AND ITALIC, MODERN				
No. 1.				62-69
" 11.				17-41
" 12.				17-26
" 13.				18-01
" 14.				21-34
" 15.				21-38
" 16.				16-60
" 17.				39
" 18.				39-42
" 19.				35-46
ROMAN AND ITALIC, OLD STYLE				
No. 20.				70-77
" 22.				78
" 100.				79
RUNIC NO. 640				191
8 Pt.	30A			\$1.45
10.	20A			1.30
12.	15A			1.25
16.	15A			1.80
20.	12A			2.30
24.	10A			2.70
36.	8A			4.05
48.	5A			4.20
RUNIC NO. 641				192
6 Pt.	30A	\$1.30,	60a \$1.00	\$2.30
8.	30A	1.90,	60a 1.50	3.40
10.	20A	1.60,	40a 1.30	2.90
12.	15A	1.50,	30a 1.30	2.80
18.	12A	2.05,	25a 1.70	3.75
20.	12A	2.60,	25a 2.30	4.90
24.	10A	3.20,	10a 2.60	5.80
48.	7A	5.65,	12a 4.90	10.55
RUNNING HAND SCRIPT NO. 2009'				336
*24 Pt. Card Font.	4A	\$2.25,	12a \$1.75'	\$4.00
*24 " Circular "	7A	3.00,	60a 9.60	12.60
RUSTIC NO. 1048'				211
10 Pt.	20A			\$2.10
12.	15A			2.30
18.	12A			3.40
24.	10A			5.15
36.	8A			6.05
48.	5A			6.75
SAXON ORNATE NO. 519				297
18 Pt.	8A	\$3.50,	25a \$3.25	\$6.75
24.	7A	\$5.00,	20a \$4.45	\$9.45
36.	6A	6.60,	15a 5.90	12.50
SAXON ORNATE SHADED NO. 520				297
18 Pt.	8A	\$3.50,	25a \$3.25	\$6.75
24.	7A	5.00,	20a 4.45	9.45
36.	6A	6.60,	15a 5.90	12.50
SAXON ORNATE SHADED NO. 521				298
18 Pt.	8A	\$2.70,	25a \$2.40	\$5.10
24.	7A	3.75,	20a 3.20	6.95
36.	6A	5.75,	15a 4.50	10.25
44.	5A	5.80,	12a 4.55	10.35
SCHOEFFER OLD STYLE				208 F-1
8 Pt.	25A	\$0.95,	50a \$1.05	\$2.00
10.	25A	1.10,	50a 1.15	2.25
12.	20A	1.15,	40a 1.35	2.50
15.	18A	1.60,	30a 1.40	3.00
18.	15A	1.80,	25a 1.70	3.50
24.	12A	2.15,	18a 1.85	4.00

				PAGE
SCHOEFFER OLD STYLE..CONTINUED				208 F-1
30.	8A	\$2.40,	12a \$2.10	\$4.50
36.	6A	2.75,	9a 2.25	5.00
48.	4A	3.20,	7a 2.80	6.00
60.	3A	4.10,	5a 2.90	7.00
72.	3A	5.40,	4a 3.10	8.50
SCORED FIGURES				7
SCOTTFORD NO. 1562				274
12 Pt.	15A	\$2.05,	30a \$2.00	\$4.05
18.	12A	2.70,	25a 2.65	5.35
24.	10A	3.50,	20a 3.45	6.95
*36.	6A	4.00,	10a 3.50	7.50
48.	5A	4.65,	5a 3.75	8.40
SECRETARY SCRIPT NO. 687				324, 325
12 Pt.	10A	\$2.15,	30a \$1.45	\$3.60
14.	10A	2.45,	30a 1.75	4.20
18.	8A	3.00,	25a 2.00	5.00
*24.	8A	4.00,	25a 2.65	6.65
SHADED NO. 1049				212
12 Pt.	15A			\$3.20
18.	12A			5.00
24.	10A			7.30
36.	8A			11.15
48.	5A			11.00
SHADED NO. 1052				215
18 Pt.	12A			\$2.40
24.	10A			3.60
36.	8A			5.15
48.	5A			5.95
SHADED NO. 1059				216
12 Pt.	15A			\$1.90
18.	12A			2.75
24.	10A			3.95
36.	8A			7.80
48.	5A			7.20
SHADED NO. 1067				218
18 Pt.	12A			\$2.40
24.	10A			2.15
36.	8A			3.20
48.	5A			6.05
SHADED NO. 1073				221
12 Pt.	15A			\$2.90
18.	12A			4.35
24.	10A			6.10
36.	8A			10.85
SHADED NO. 1076				224
12 Pt.	15A			\$2.30
18.	12A			3.25
24.	10A			3.95
36.	8A			7.60
SHADED NO. 1077				225
12 Pt.	15A			\$2.75
18.	12A			4.15
24.	10A			5.50
36.	8A			10.65
SHADED NO. 1079				226
12 Pt.	15A			\$1.75
18.	12A			2.35
24.	10A			3.50
36.	8A			4.80
48.	5A			5.65
SHADED NO. 1087				231
12 Pt.	15A			\$3.05
18.	12A			4.10
24.	10A			5.95
36.	8A			9.35
48.	5A			10.55
SHADED NO. 1088				232
12 Pt.	15A			\$2.45
18.	12A			3.60
22.	12A			4.95
36.	8A			8.30
48.	5A			7.90

* Fonts either changed in body or scheme.

	PAGE
SHADED NO. 1090	234
12 Pt. 15A	\$2.15
18. 12A	2.90
24. 10A	3.80
36. 8A	8.40
48. 5A	7.20
SHADED NO. 1092	236
12 Pt. 15A	\$1.90
18. 12A	3.00
24. 10A	3.85
36. 8A	6.25
48. 5A	6.30
SHADED NO. 1509	240
12 Pt. 15A \$3.00, 30a \$2.50	\$5.50
16. 15A 4.20, 30a 3.50	7.70
20. 12A 4.50, 25a 3.70	8.20
24. 10A 6.00, 20a 4.10	10.10
SHADED NO. 1541	261
12 Pt. 15A \$2.60, 30a \$2.20	\$4.80
18. 12A 3.00, 25a 2.50	5.50
22. 12A 4.15, 25a 3.50	7.65
28. 10A 5.10, 20a 4.25	9.35
36. 8A 7.55, 15a 6.50	14.05
48. 5A 6.60, 5a 4.00	10.60
SHADED NO. 1552	268
18 Pt. 12A \$4.00, 25a \$3.00	\$7.10
24. 10A 6.00, 20a 4.35	10.35
36. 8A 8.50, 15a 6.35	14.85
48. 5A 8.00, 5a 5.30	13.30
SHADED NO. 1553	269
18 Pt. 12A \$3.00, 25a \$2.35	\$5.35
24. 10A 4.00, 20a 2.85	6.85
36. 8A 6.00, 15a 4.15	10.15
48. 5A 4.75, 12a 3.00	7.75
SHADED GOTHIC NO. 1558	271
12 Pt. 15A \$1.80, 30a \$1.25	\$3.05
18. 12A 2.50, 25a 1.75	4.25
24. 10A 3.50, 20a 2.45	5.95
36. 8A 5.00, 15a 3.90	8.90
48. 5A 4.00, 5a 2.75	6.75
SHADED TEXT NO. 537	304
18 Pt. 7A \$2.60, 20a \$2.50	\$5.10
24. 6A 4.00, 15a 3.40	7.40
36. 4A 5.00, 10a 4.45	9.45
SHADED TEXT NO. 539	308
18 Pt. 8A \$2.30, 25a \$2.20	\$4.50
24. 7A 3.40, 20a 3.00	6.40
36. 6A 5.00, 15a 4.35	9.35
48. 5A 7.00, 12a 5.50	12.50
SHADED TEXT NO. 542	310
12 Pt. 10A \$2.10, 30a \$1.80	\$3.90
18. 8A 2.75, 25a 2.00	4.75
24. 7A 4.00, 20a 2.75	6.75
36. 6A 5.55, 15a 4.00	9.55
SHADED TITLE TEXT NO. 508	289
10 Pt. 14A \$1.80, 40a \$1.75	\$3.55
12. 10A 1.70, 30a 1.65	3.35
18. 8A 2.10, 25a 2.00	4.10
22. 8A 2.80, 25a 2.70	5.50
28. 7A 3.60, 20a 3.40	7.00
36. 6A 4.20, 15a 4.00	8.20
SNOW CARD NO. 630	318
10 Pt. 20A \$2.10, 40a \$1.80	\$3.90
12. 15A 2.15, 30a 1.90	4.05
18. 12A 3.35, 25a 2.65	6.00
24. 10A 4.35, 20a 3.40	7.75
36. 8A 6.50, 15a 5.40	11.90
48. 5A 6.00, 5a 4.60	10.60
SKELETON NO. 630	131
18 Pt. 12A	\$1.90
24. 10A	2.50
SMITH-PREMIER TYPEWRITER	\$200
12 Pt. 20A \$3.40, 108a \$4.10	\$7.50

	PAGE
SOCIETY CUTS	443
SPACE RULE	11
ST. ALBANS NO. 1561	278
12 Pt. 15A \$1.55, 30a \$1.50	\$3.05
18. 12A 2.35, 25a 2.00	4.35
24. 10A 3.00, 20a 2.40	5.40
36. 8A 4.60, 15a 3.60	8.20
48. 7A 6.00, 12a 4.80	10.80
STATE SEALS	407
SUPERIOR AND INFERIOR FRACTIONS	6
SUPERIOR AND INFERIOR LETTERS	6
TEUTONIC ORNAMENTED NO. 518	296
28 Pt. 7A \$6.00, 20a \$4.65	\$10.65
36. 6A 7.00, 15a 5.00	12.00
48. 5A 10.20, 12a 8.00	18.20
TEUTONIC SHADED NO. 523	300
22 Pt. 8A \$4.00, 20a \$3.65	\$7.65
28. 7A 6.00, 20a 4.75	10.75
36. 6A 6.70, 15a 5.00	11.70
48. 4A 10.00, 10a 7.40	17.40
TITLE NO. 101	98, 99
9 Pt. 20A	\$1.70
10. 20A	2.05
11. 20A	2.30
12. 15A	1.90
14. 15A	2.35
16. 15A	2.70
18. 12A	2.80
20. 12A	3.70
22. 12A	4.50
24. 10A	4.50
*30. 8A	5.35
*36. 6A	5.40
TITLE NO. 102	100, 101
9 Pt. 20A	\$1.30
10. 20A	1.50
11. 20A	1.75
12. 15A	1.50
14. 15A	2.25
16. 15A	2.20
18. 12A	2.40
20. 12A	2.85
22. 12A	3.25
24. 10A	3.60
*30. 8A	4.55
TITLE NO. 103	102
9 Pt. 20A	\$1.20
10. 20A	1.50
11. 20A	1.75
12. 15A	1.40
14. 15A	1.70
16. 15A	2.05
18. 12A	2.05
22. 12A	3.20
TITLE NO. 104	103
14 Pt. 15A	\$1.65
16. 15A	2.20
TITLE NO. 105	104
11 Pt. 20A	\$1.65
12. 15A	1.50
14. 15A	1.80
16. 15A	2.05
18. 12A	2.30
20. 12A	2.70
22. 12A	2.95
24. 10A	3.30
*30. 8A	4.20
TITLE NO. 106	105
10 Pt. 20A	\$1.50
12. 15A	1.65
14. 15A	1.85
16. 15A	2.25
18. 12A	2.50

* Fonts either changed in body or scheme.

				PAGE					PAGE	
TITLE NO. 106..CONTINUED				105	TITLE SCRIPT NO. 2004				333	
20.....	12A.....			\$2.90	12 Pt. Card Font. 5A	\$1.60,	16a	\$1.40	\$3.00	
22.....	12A.....			2.70	*18 " " " " 4A	1.90,	12a	1.60	3.50	
24.....	10A.....			3.35	*24 " " " " 3A	2.50,	10a	2.00	4.50	
TITLE NO. 107				103	12 " Circular " 14A	5.65,	160a	10.00	15.65	
11 Pt.....	20A.....			\$1.85	18 " " " " 9A	5.00,	90a	9.00	14.00	
12.....	15A.....			1.60	*24 " " " " 7A	4.50,	54a	8.10	12.60	
14.....	15A.....			1.90	TITLE TEXT NO. 507				288	
16.....	15A.....			2.20	10 Pt.....	14A	\$2.10,	40a	\$2.10	\$4.20
TITLE CONDENSED NO. 160				120, 121	12.....	10A	2.05,	30a	2.00	4.05
8 Pt.....	30A	\$1.50,	60a	\$1.45	18.....	8A	2.50,	25a	2.25	4.75
10.....	20A	1.20,	40a	1.10	*24.....	7A	3.40,	20a	3.00	6.40
12.....	15A	1.10,	30a	1.05	*30.....	6A	4.20,	18a	3.65	7.85
18.....	12A	1.75,	25a	1.70	36.....	6A	4.60,	15a	4.00	8.60
*24.....	10A	2.20,	20a	2.15	TRADE CUTS				412, 436	
*30.....	9A	3.00,	18a	2.80	TUDOR BLACK				320 J, K	
*32.....	8A			3.30	6 Pt.....	15A	\$1.00,	50a	\$1.25	\$2.25
*36.....	8A	4.00,	15a	4.00	8.....	15A	1.25,	50a	1.50	2.75
48.....	7A	5.50,	12a	5.45	10.....	12A	1.25,	36a	1.50	2.75
*60.....	5A	5.25,	5a	5.25	12.....	9A	1.00,	30a	1.75	2.75
TITLE EXPANDED NO. 182				130	18.....	8A	1.40,	25a	2.00	3.40
6 Pt.....	30A	\$2.00,	60a	\$1.80	20.....	5A	1.50,	15a	2.00	3.50
8.....	30A	2.75,	60a	2.30	24.....	5A	2.15,	15a	2.60	4.75
10.....	20A	2.35,	40a	2.00	36.....	4A	2.40,	12a	3.10	5.50
12.....	15A	2.20,	30a	2.00	42.....	4A	2.50,	12a	3.50	6.00
18.....	12A	3.00,	25a	2.65	48.....	5A	4.85,	8a	3.65	8.50
TITLE ITALIC NO. 141				115	72.....	3A	7.00,	5a	5.00	12.00
6 Pt.....	30A	\$1.70,	60a	\$1.50	UNITED STATES EMBLEMS				441	
8.....	30A	2.15,	60a	2.00	UNITED STATES FLAGS				442	
9.....	20A	1.50,	40a	1.30	VENETIAN NO. 650				316	
10.....	20A	1.75,	40a	1.60	10 Pt.....	20A	\$2.55,	40a	\$2.00	\$4.55
11.....	20A	1.80,	40a	1.60	12.....	15A	2.50,	30a	2.00	4.50
12.....	15A	1.80,	30a	1.70	18.....	12A	3.50,	25a	2.50	6.00
18.....	12A	3.00,	25a	2.35	VICTORIA NO. 540				309	
TITLE ITALIC NO. 144				117	8 Pt.....	20A	\$3.00,	60a	\$2.80	\$5.80
6 Pt.....	30A	\$1.50,	60a	\$1.40	10.....	14A	1.90,	40a	1.70	3.60
8.....	30A	1.75,	60a	1.75	12.....	10A	2.20,	30a	2.00	4.20
10.....	20A	1.55,	40a	1.50	18.....	8A	2.85,	25a	2.50	5.35
12.....	15A	1.65,	30a	1.65	22.....	8A	4.30,	25a	4.00	8.30
TITLE ROMAN NO. 140				113, 114	28.....	7A	5.00,	20a	4.45	9.45
5½ Pt.....	30A	\$1.00,	60a	\$1.55	WHITEFIELD NO. 1563				275	
5.....	30A	1.50,	60a	1.40	12 Pt.....	15A	\$2.10,	30a	\$2.10	4.20
6.....	30A	1.60,	60a	1.60	18.....	12A	2.50,	25a	2.50	5.00
7.....	30A	1.90,	60a	1.85	24.....	10A	3.00,	20a	2.95	5.95
8.....	30A	2.05,	60a	2.00	36.....	8A	4.20,	15a	4.10	8.30
9.....	20A	1.30,	40a	1.30	48.....	5A	3.60,	5a	2.50	6.10
10.....	20A	1.70,	40a	1.65	WOOD TYPE				449-464	
11.....	20A	1.70,	40a	1.65	WOOD ORNAMENTS				353	
12.....	15A	1.70,	30a	1.70	YOST TYPEWRITER				320 P	
18.....	12A	2.50,	25a	2.50	10 Pt.....	20A	\$2.10,	90a	\$4.65	\$6.75
TITLE ROMAN NO. 143				116	12.....	20A	1.85,	90a	4.65	6.50
6 Pt.....	30A	\$1.50,	60a	\$1.40						
8.....	30A	1.75,	60a	1.75						
10.....	20A	1.50,	40a	1.45						
12.....	15A	1.65,	30a	1.65						

Fonts either changed in body or scheme.

INDEX TO MACHINERY AND MATERIALS

Printers' Wood Goods . . . 466 to 495
Printers' Machinery . . . 496 to 544
Printers' Supplies . . . 545 to 592

	PAGE
ACME EXTENSION METAL FURNITURE	504
Acme Staple Binders	533-535
Adams-on Disc Cover	584
Addressing Machines	544
American Counter	519
American Job Press Counter	518
American Lead and Rule Cutters	540, 541
American Polhemus Cabinets	475, 478
American Steel-Run Cabinets	480
Army Press	509
Automatic Numbering Machines	515-517
BELLOWS	550
Bentravato	581
Benzine Cans	556
Blankets	560
—Felt	560
—Rubber	560
Bodkins	545
Bone Folders	551
Bookbinders' Cabinets	482
Bookbinders' Case	482
Book Sewing Machine	532
Book Stabbers	528
Boston Card Cutter	527
Boston Lead Rack	489
Boxwood	551
Brackets	549
Brass Gallies	563, 564
Brass Label Holders	548
Brass Rule Curving Machines	543
Brayers	578
Bronze Powders	587
Bronzing Mitten	584
Bronzing Pad	584
Brewer Quoins	554
Brewer Quoin-Lock	555
Brushes	561
Barbank's Embossing Composition	583
CABINETS	475-487
—American Polhemus	475-476
—American Steel-Run	480
—Blank Case	484
—Bookbinders	482
—Cut	484, 485
—Electro and Cut	485
—Galley	487
—Handy Letter Board	483
—Index Electro	484, 485
—Ink and Roller	483
—Linotype	486
—Porter's Extension Front	479
—Specimen	486
—Wisconsin, Hard-Wood	478
—Wisconsin, Steel-Run	481
—Wisconsin Window	477
—Wood Type	482
Card Cutters	527
Cases	467-472
—Bookbinders	482

	PAGE
Cases—Continued.	
—California Job	471
—Combination Quarter	470
—Compact Rule	469
—Double Lower	471
—Full Size	467
—Harris Rule	468, 469
—Individual Job	471
—Individual Lead or Rule	470
—Mammoth Wood Type	472
—Metal Furniture	472
—New York Job	471
—Patent Clasp	467, 468
—Patterson Job	471
—Rooker	468-471
—Rule	468-470
—Script or Wood Type	472
—Space and Quad	472
—Special	468
—Three-Quarter	467
—Two-Third	468
—Yankee Job	472
Case Racks	474
Case Stands, Wood	473, 474
Cement Brush	561
Challenge Country Cylinder Press	509
Chases	572-577
—Book or Shifting-Bar	574
—Cast Iron	576
—Electrotype	576
—For Job Presses	577
—Heading, with Cross-Bar	576
—Newspaper, Folio	572
—Newspaper Quarto	573
—Poster	575
—Quadruple	573
—Spider, for Job Presses	577
—Stereotype	577
—Twin	572
—Twin, with Bars	573
—Wrought Iron, for Job Presses	577
Cheapeake Economy Compound	582
Combination Paper Jogger	514
Combination Shuteboard and Type High Machine	539
Compact Rule Case	469
Composing Rules	545
Composing Stick Rack	548
Composing Sticks	546, 547
—American Job	547
—Buckeye	546
—Common Screw	546
—"C" Slot	546
—Grover	546
—Perfect News	547
—Poster	547
—Yankee Job	546
Copper Thin Spaces	550
Copy Holder, Kelsey	548
Counters	518, 519
—American	519
—American Job Press	518

Counters—Continued.			
—Double Dial Alarm	510		
—Durant	519		
Counter Shafts	514		
Cranston Presses	505-508		
Curving Machines, Rule	543		
Cut Cabinets	484, 485		
Cutting and Creasing Press, Gally	502		
BILLINGHAM PRESS PUNCH	553		
Disc Cover, Adamson	584		
Dividers	550		
Double Case Brackets	477		
Double Dial Alarm Counter	519		
Dryers	587		
Drying Racks	494, 495		
—Chicago	494		
—Koener's Interlocking	495		
—Movable	494		
—New York	494		
Durant Counter	519		
ECONOMIC PROOF PRESS.	513		
Elastic Padding Glue	580		
Electricity Dissipater	581		
Electro and Cut Cabinet	484, 485		
Elite Rule Bender	542		
Embossing Composition	583		
Embossing, Guide to	583		
Embossing Presses	501		
Engravers' Tools	551		
Engravers' Wood	551		
Eureka Lead Rack	489		
Eureka Type Wash	582		
Extension Front Cabinets	479		
Eyeletting Machines	537		
Eyelet Punch and Set	537		
Eye Shades	547		
FOLDERS, BONE AND STEEL	551		
Foot Sticks	490, 576		
Form Truck	577		
Furniture, L. S. Wood	490, 491		
GALLEY BRACKETS.	488		
Galley Cabinets	487		
Galley Proof Press	513		
Galley Racks	488		
Galleys	562, 564		
—All Brass	563		
—Closed End Mailing	562		
—Lincoln	564		
—Mailing	563		
—Plate Zinc Storage	564		
—Smooth Lined	562		
—Success, Riveted, all Brass	564		
—Unlined	562		
—Wooden	563		
Gally, Universal Presses	497-502		
Gauge Pin Drawer	552		
Gauge Pins and Guides	552		
Gloss Varnishes	587		
Glue Pot	580		
Gordon Presses	496		
Gripper Perforator	558		
Guides for Platen Presses	552		
HACK SAWS	550		
Hand Perforator	538		
Hand Rollers	578		
Hand Press, Washington	512		
Hand Stabbing Machines	528		
Handy Letter Board Cabinets	483		
Hangers	514		
Harris Rule Cases	469		
Hempel Quoins	554		
Hercules Liquid Overlay	581		
IDEAL HAND CYLINDER PRESS	511		
Ideal Inking Apparatus	511		
Illustration of Cases	470-472		
Imposing Surfaces, Iron	493		
Imposing Tables and Stones	492, 493		
Indexed Electrotpe Cabinets	484, 485		
Individual Lead or Rule Case	470		
Inks	585-587		
Ink and Roller Cabinet	483		
Ink Fountains	496		
Ink Knives	551		
Inkoleum	581		
Ink Reducers	581, 582		
Ink Slabs, Marble	493		
Ink Slice	551		
Ink Spade	551		
Iron Side and Foot Sticks	576		
Interlocking Drying Racks, Koener's	495		
KELSEY COPY HOLDER	548		
Keystone Hack Saw	550		
Knives	551, 580		
LABEL HOLDER	548		
Labor-Saving Furniture, Wood	490, 491		
Lamp Holder	549		
Lead and Rule Cutters	540, 541		
Leader and Sort Box	470, 564		
Lead or Rule Case	470		
Lead Racks	489		
Letter Board Cabinets	483		
Letter Boards	483		
Linotype Matrix Cabinet	486		
Linotype Planer	466		
Liquid Cement Brush	561		
Liquid Overlay	581		
Liquid Padding Glue	580		
Lye Brushes	561		
MAGNIFYING GLASS	551		
Mailing Galley	562, 563		
Mailing Machines	544		
Make-up Rules	545		
Mallets	466		
Marble Stones	492, 493		
May's Patent Leader and Sort Box	564		
Metallic Tape Coupler	561		
Midget Safety Quoin	555		
Mitre Boxes	550		
Mitering Machines	542		
Monitor Wire Stitchers	529, 532		
Morton Lock-up	556		
NARROW MARGIN REGISTER HOOKS	567		
Neverslip Quoin	557		
New York Space-saving Case Stands	474		
Numbering Machines	515-517		
—Bates' Automatic	517		
—Paragon	517		
—Wetter	515, 516		
OFFICIAL HAND LEVER PRESS	504		
Overhead Power Fixtures	514		
Overlay Knife	551		
Overlay Liquid	581		
PADDING GLUE, ELASTIC	580		
Pallet Ink Knives	551		
Paper Box Cutting and Creasing Press	502		
Paper Counter	580		
Paper Cutters	520, 526		
—Advance Lever	523		
—Advance Power	525		
—Challenge Lever	522		
—Challenge Pony Lever	523		
—Challenge Power	526		
—Chandler & Price	522		
—Clipper	524		
—Peerless Gem	520, 521		
—Peerless Power	526		
—Reliance Lever	523		
—Utility	524		
Paper Folders, Bone and Steel	551		
Paper Jogger	514		
Paper Knife	551		
Patent Tilting Case Bracket	477		
Peerless Press	503		

	PAGE		PAGE
Perforator	538	Staple Binders	533-536
Pilot Hand Lever Press	504	—Acme	533-535
Planers	466	—Breech Loader	536
Pliers	561	—Hercules	536
Power Fixtures	514	—Sure Shot No. 1	535
Press Guides	552	—Other Staple Binders	536
Press Points	553	Staples, Wire	536
Press Punches	553	Steel-Run Cabinets	476
Printers' Brushes	561	Stereotype Blocks	565-571
Printers' Dividers	550	—Mahogany	565, 566
Printers' Eye Shade	547	—Sectional Metal	567
Printers' Saw Table	539	—Weatherly Extension	568-571
Printers' Trucks	557	—Wesel Iron Grooved	567
Printing Inks	585-587	Stitching Machines	529-532
Printing Presses	496-512	Success Card Cutter	527
—Army	509		
—Challenge Country Cylinder	509	TABLET KNIFE	580
—Chandler & Price Gordon	496	Tablet Presses	579
—Cranston Improved Book and News	506	—Cotts Improved	579
—Cranston Improved Newspaper	506	—Union	579
—Cranston Improved Two-Roller	507	Tape	560
—Cranston Newspaper	505	Tape Couplers	561
—Cranston-Victor Commercial	508	Tape Fasteners	560
—Gally Universal	497-500	Tennis Book Sewing Machine	532
—Ideal Hand Cylinder	511	Tilting Case Brackets	477
—Improved Country Prouty	510	Trucks	557, 577
—New Leverless Monona	510	Tweezers	545
—Official Hand Lever	504	Type-High Gauge	549
—Peerless	503	Type-High Machine	539
—Pilot Hand Lever	504	Type Measures	548
—Washington Hand	512	Type Wash, Eureka	582
Proof Planers	466	Typographic Numbering Machines	515, 516
Proof Presses	513		
Proof Rollers	578	UNION LOCKABLE QUOIN	555
Punching Machine	537	Union Movable Galley Rack	488
Pulleys	514	Union Reversible Galley Bracket and Socket	488
		Union Safe Benzine Can	559
QUOIN LOCK	555	Union Storage Can	559
Quoins	554-557	Union Tablet Apparatus	579
—Mechanical	554-557	Universal Embossing Press	501
		Universal Cutting and Creasing Press	502
RAWHIDE MALLETS	466	Universal Presses	497, 502
Reducing Glass	551	Universal Stamping Press	501
Reducing Varnishes	587		
Register Hooks	567	VARNISHES	587
Reglet Cases, Labor Saving	490		
Reglet, Labor Saving	490	WASHINGTON HAND PRESS	512
Roller Supporters	578	Weatherly Extension Blocks	568-571
Rollers	578	Wesel Iron Grooved Block	567
Rule Bender	543	Wetter Numbering Machines	515, 516
Rule Cases	468-470	Whitstone's Embossing Composition	583
Rule Curving Machine	543	Wickersham Quoins	556
Rule Cutters	540-541	Wire Staples	536
Rule Shaper	543	Wire Stitchers	529-532
		Wisconsin Combination Quarter Cases	470
SAWS	539, 550	Wisconsin Hard Wood-Cabinets	478
Saw Table	539	Wisconsin Lead Racks	489
Shafting	514	Wisconsin Steel Run-Cabinets	481
Shooting Sticks	550	Wisconsin Window Cabinet	477
Shute Board and Type-High Machines	539	Wooden Gallies	567
Side Sticks	490, 576	Wooden Mallets	466
Specimen Cabinets	486	Wooden Shooting Sticks	550
Stabbing Machine, Hand	528	Wood Furniture	490, 492
Stamping Press, Gally Universal	501	Wood Type Cabinets	482
Stands	473, 474	Wood Type Racks	474, 482

LABOR-SAVING LEADS

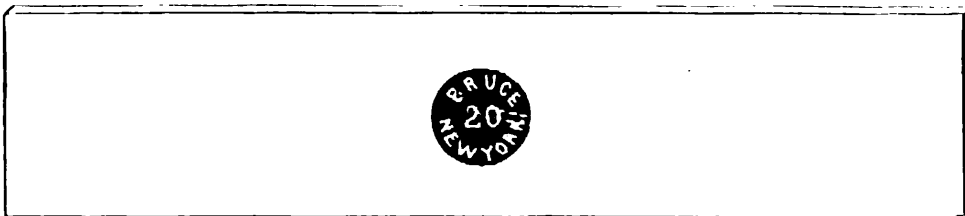
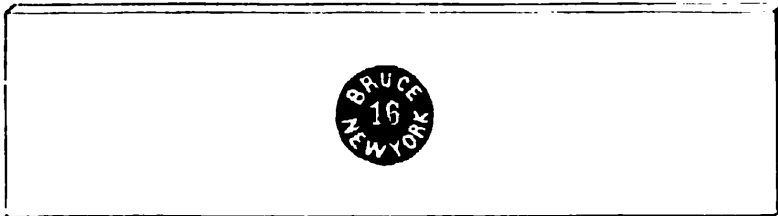
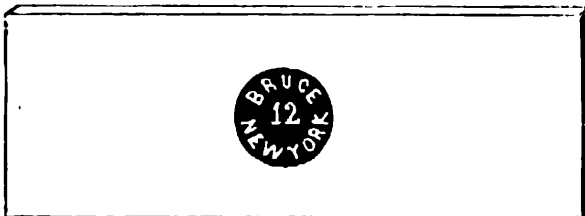
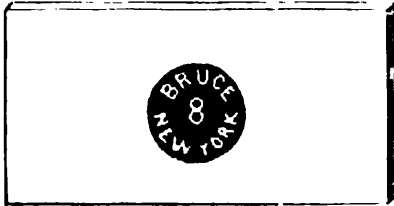
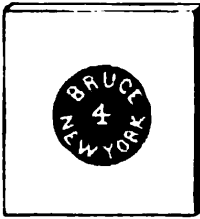

THESE LEADS (or SLUGS, as they are called when 6-Point or over), are cast 2, 3, 6 and 12-Point in thickness, and cut to 13 different lengths, viz.: 48, 54, 60, 66, 72, 84, 96, 120, 168, 182, 216, 240 and 264-Point.

The smallest assortment of either thickness weighs 25 pounds.

They are cut very accurately and the length of each lead stamped on it.

No job office should be without them. The saving in compositors' time will soon pay for them.

PRICE:

2 or 3-Point,
25c. per lb.
6 or 12-Point,
25c. per lb.

NUMBERED SLUGS

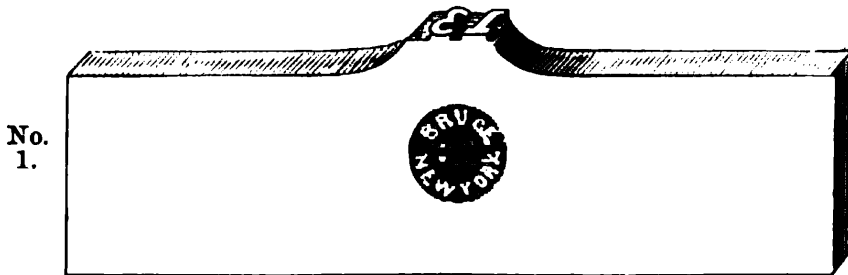

<p>PRICE:</p> <p>No. 1, Electro, 20c. No. 2, Metal, 15c. No. 3, Brass, 20c.</p>

BRUCE TYPE FOUNDRY, 13 CHAMBERS STREET, NEW YORK.

ACCENTS

WE FURNISH ACCENTS, WHEN REQUIRED, FOR ALL OUR TYPE, AS BELOW:

← FOR ALL BOOK AND NEWS TYPE →

Á À Â Ã Ä Å É È Ê Ë Ì Í Î Ï Ó Ô Õ Ö Ù Ú Û Ü Ñ Ç
 á à â ã ä å é è ê ë ì í î ï ó ô õ ö ù ú û ü ñ ç
 ā ē ī ō ū & ā ē ī ō ū

*Á À Â Ã Ä Å É È Ê Ë Ì Í Î Ï Ó Ô Õ Ö Ù Ú Û Ü Ñ Ç
 á à â ã ä å é è ê ë ì í î ï ó ô õ ö ù ú û ü ñ ç
 ā ē ī ō ū & ā ē ī ō ū*

← FOR ALL DISPLAY FONTS →

À Á É È Ê Õ Ñ Ç
 á à â ã ä å é è ê ì í ó ô ö õ ù ú û ü ñ ç

← FOR ALL SCRIPT FONTS →

*á à â ã ä å é è ê ë ì í î ï ó ô õ ö ù
 ú û ü ñ ç*

PRICE LIST OF BODY TYPE

SUBJECT TO DISCOUNT

POINT BODIES.	25 LBS.	500 LBS.	1000 LBS.
	TO 500 LBS.	TO 1000 LBS.	AND OVER.
	Per lb.	Per lb.	Per lb.
3½ Point	\$5 00	\$4 75	\$4 50
3½ " on 4½-Point	3 50	3 40	3 30
4½ "	1 60	1 55	1 50
5 "	1 20	1 15	1 10
5½ "	0 74	0 72	0 71
6 "	0 64	0 62	0 61
7 "	0 56	0 54	0 53
8 "	0 52	0 50	0 49
9 "	0 48	0 46	0 45
10 "	0 46	0 44	0 43
11 "	0 44	0 42	0 41
12 "	0 42	0 40	0 40
14 "	0 40	0 40	0 40
15 "	0 40	0 40	0 40
16 to 28 Point incl.	0 40	0 40	0 40
Above 28 Point at Second-class Prices			

Roman and German Body Type is put up in fonts of 25, 50 and 100 pounds, or some multiple of these weights. Included in each 25 pounds are 5 pounds of Spaces and Quads, and same proportions in larger fonts.

Italic and Accents will not be sent with Roman fonts unless specially ordered. Smallest font of Italic furnished weighs 5 pounds. A pair of full-size cases holds 50 pounds of body type.

SPACES AND QUADS IN JOB FONTS

Spaces and Quads are put up in Job Fonts at the following prices:

	Per Font		Per Font
5 Point	\$1 40	24 Point	\$0 60
5½ "	1 00	28 "	0 55
6 "	0 65	30 "	0 50
7 "	0 65	32 "	0 50
8 "	0 65	36 "	0 55
9 "	0 60	40 "	0 60
10 "	0 55	42 "	0 60
11 "	0 60	44 "	0 60
12 "	0 60	48 "	0 80
14 "	0 60	54 "	1 10
15 "	0 60	60 "	1 15
16 "	0 55	72 "	1 25
18 "	0 55	84 "	0 90
20 "	0 60	96 "	1 70
22 "	0 50	120 "	1 40

Spaces and Quads are also put up in assorted fonts of five pounds, at Body Type Prices.

BRUCE TYPE FOUNDRY, 13 CHAMBERS STREET, NEW YORK.

PRICE LIST OF JOB TYPE

SUBJECT TO DISCOUNT

POINT BODIES	Second-Class Type in fonts of 25 lbs. and over	Second-Class Special Type in fonts of 25 lbs. and over	Third-Class Type Scripts, Pat- ented Letters, etc. 25 lbs. and over
4½ Point	Per lb. \$2 50	Per lb. \$2 80	Per lb. \$3 20
5 "	1 80	2 00	2 80
5½ "	1 44	1 60	2 40
6 "	1 16	1 28	2 00
7 "	1 00	1 12	1 80
8 "	0 90	1 00	1 60
9 "	0 80	0 90	1 44
10 "	0 74	0 82	1 30
11 "	0 70	0 78	1 22
12 "	0 66	0 74	1 16
14 "	0 62	0 70	1 12
15 "	0 62	0 70	1 08
16 "	0 60	0 70	1 06
18 "	0 60	0 66	1 00
20 "	0 60	0 66	0 94
22 "	0 56	0 64	0 90
24 "	0 56	0 64	0 90
28 "	0 56	0 64	0 86
30 "	0 56	0 62	0 84
32 "	0 56	0 62	0 82
36 "	0 56	0 62	0 82
40 "	50 lbs. and over \$0 54	50 lbs. and over \$0 60	50 lbs. and over \$0 78
42 "	0 54	0 60	0 72
44 "	0 54	0 60	0 72
48 "	0 54	0 60	0 72
54 "	Sold in Fonts only	Sold in Fonts only	Sold in Fonts only
60 "			
72 "			
84 "			
96 "			
120 "			

ALLOWANCE FOR OLD TYPE AND OTHER METALS

Old type (clean and unmixed with other metals), electrotypes, leads and brass, delivered at foundry free, will be taken at current prices in even exchange for new type or printing material.

Customers sending in old metal are requested to mark their names on all packages, and to forward by mail a shipping receipt or bill of lading, with the net weight of each kind of material, as soon as shipment is made. Compliance with this request will aid in identifying shipments, and prevent errors. Ship as "old metal" to secure low freight rate.

SPECIAL NOTICE.—Zinc plates, metal containing zinc, or type and other plates mixed with zinc plates, and stereotype plates, will not be received at any price. Type, electrotype plates, leads and brass, must be packed separately, as the value of each differs.

SUPERIOR AND INFERIOR LETTERS

FOR PRICES, SEE COLUMN 3, PAGE 5

<p style="text-align: center;">FIVE POINT. abcdefghijklmnopqrstuvwxy</p> <p style="text-align: center;">FIVE-AND-A-HALF POINT. abcdefghijklmnopqrstuvwxy</p> <p style="text-align: center;">SIX POINT. abcdefghijklmnopqrstuvwxy</p> <p style="text-align: center;">SEVEN POINT. abcdefghijklmnopqrstuvwxy</p> <p style="text-align: center;">EIGHT POINT. abcdefghijklmnopqrstuvwxy</p> <p style="text-align: center;">NINE POINT. abcdefghijklmnopqrstuvwxy</p> <p style="text-align: center;">TEN POINT. abcdefghijklmnopqrstuvwxy</p> <p style="text-align: center;">ELEVEN POINT. abcdefghijklmnopqrstuvwxy</p> <p style="text-align: center;">TWELVE POINT. abcdefghijklmnopqrstuvwxy</p>	<p style="text-align: center;">FIVE POINT. abcdefghijklmnopqrstuvwxy</p> <p style="text-align: center;">FIVE-AND-A-HALF POINT. abcdefghijklmnopqrstuvwxy</p> <p style="text-align: center;">SIX POINT. abcdefghijklmnopqrstuvwxy</p> <p style="text-align: center;">SEVEN POINT. abcdefghijklmnopqrstuvwxy</p> <p style="text-align: center;">EIGHT POINT. abcdefghijklmnopqrstuvwxy</p> <p style="text-align: center;">NINE POINT. abcdefghijklmnopqrstuvwxy</p> <p style="text-align: center;">TEN POINT. abcdefghijklmnopqrstuvwxy</p> <p style="text-align: center;">ELEVEN POINT. abcdefghijklmnopqrstuvwxy</p> <p style="text-align: center;">TWELVE POINT. abcdefghijklmnopqrstuvwxy</p>
---	---

SUPERIOR AND INFERIOR FRACTIONS

FOR PRICES, SEE COLUMN 3, PAGE 5

<p style="text-align: center;">FIVE POINT—No. 1. 1234567890 1/4 1/2 1234567890</p> <p style="text-align: center;">FIVE-AND-A-HALF POINT—No. 1. 1234567890 1/4 1/2 1234567890</p> <p style="text-align: center;">SIX POINT—No. 1. 1234567890 1/4 1/2 1234567890</p> <p style="text-align: center;">SEVEN POINT—No. 1. 1234567890 1/4 1/2 1234567890</p> <p style="text-align: center;">EIGHT POINT—No. 1. 1234567890 1/4 1/2 1234567890</p> <p style="text-align: center;">NINE POINT—No. 1. 1234567890 1/4 1/2 1234567890</p> <p style="text-align: center;">TEN POINT—No. 1. 1234567890 1/4 1/2 1234567890</p> <p style="text-align: center;">ELEVEN POINT—No. 1. 1234567890 1/4 1/2 1234567890</p> <p style="text-align: center;">TWELVE POINT—No. 1. 1234567890 1/4 1/2 1234567890</p>	<p style="text-align: center;">PATENT FIGURES.</p> <p style="text-align: center;">FIVE POINT—No. 2. 1234567890 1/4 1/2 1234567890</p> <p style="text-align: center;">FIVE-AND-A-HALF POINT—No. 2. 1234567890 1/4 1/2 1234567890</p> <p style="text-align: center;">SIX POINT—No. 2. 1234567890 1/4 1/2 1234567890</p> <p style="text-align: center;">SEVEN POINT—No. 2. 1234567890 1/4 1/2 1234567890</p> <p style="text-align: center;">EIGHT POINT—No. 2. 1234567890 1/4 1/2 1234567890</p> <p style="text-align: center;">NINE POINT—No. 2. 1234567890 1/4 1/2 1234567890</p> <p style="text-align: center;">TEN POINT—No. 2. 1234567890 1/4 1/2 1234567890</p>
---	--

BRUCE TYPE FOUNDRY, 13 CHAMBERS STREET, NEW YORK.

PIECE FRACTIONS

FOR PRICES,
SEE COLUMN 2, PAGE 5

SIX POINT.....	<u>1234567890</u>	1234567890	$\frac{2}{16}$ $\frac{15}{16}$ $\frac{75}{100}$ $\frac{199}{100}$ -
EIGHT POINT....	<u>1234567890</u>	1234567890	$\frac{4}{8}$ $\frac{15}{16}$ $\frac{95}{100}$ $\frac{750}{1000}$ -
NINE POINT.....	<u>1234567890</u>	1234567890	$\frac{4}{8}$ $\frac{15}{16}$ $\frac{3}{16}$ $\frac{99}{100}$ -
TEN POINT.....	<u>1234567890</u>	1234567890	$\frac{4}{8}$ $\frac{9}{10}$ $\frac{3}{16}$ $\frac{700}{1000}$ -
ELEVEN POINT..	<u>1234567890</u>	1234567890	$\frac{4}{8}$ $\frac{9}{10}$ $\frac{95}{100}$ $\frac{700}{1000}$ -
TWELVE POINT..	<u>1234567890</u>	1234567890	$\frac{4}{8}$ $\frac{3}{16}$ $\frac{15}{16}$ $\frac{99}{100}$ -

ITALIC FIGURES

FOR PRICES,
SEE COLUMN 2, PAGE 5

OLD STYLE.	MODERN.
FIVE POINT..... <i>1234567890</i>	<i>1234567890</i> \$.....SIX POINT
SIX POINT..... <i>1234567890</i>	<i>1234567890</i> \$.....SEVEN POINT
SEVEN POINT..... <i>1234567890</i>	<i>1234567890</i> \$.....EIGHT POINT
EIGHT POINT..... <i>1234567890</i>	<i>1234567890</i> \$.....NINE POINT
NINE POINT..... <i>1234567890</i>	<i>1234567890</i> \$.....TEN POINT
TEN POINT..... <i>1234567890</i>	<i>1234567890</i> \$....ELEVEN POINT
ELEVEN POINT.... <i>1234567890</i>	<i>1234567890</i> \$...TWELVE POINT
TWELVE POINT.... <i>1234567890</i>	<i>1234567890</i> \$..FOURTEEN POINT
FOURTEEN POINT.. <i>1234567890</i>	

CANCELLED, POINTED AND SCORED FIGURES--10 PT.

FOR PRICES, SEE COLUMN 2, PAGE 5

CANCELLED FIGURES.	POINTED FIGURES.	SCORED FIGURES.
<i>1234567890</i>	1234567890	<u>1234567890</u>

COMMERCIAL SIGNS

FOR PRICES,
SEE COLUMN 1, PAGE 5

<p>FIVE-AND-A-HALF POINT. 1 2 3 4 5 6 7 8 9 @ # \$ % & / ° ' ¢</p>	<p>SIX POINT. 1 2 3 4 5 6 7 8 9 @ # \$ % & / ° ' ¢</p>	<p>SEVEN POINT. 1 2 3 4 5 6 7 8 9 @ # \$ % & / ° ' ¢</p>
<p>EIGHT POINT. 1 2 3 4 5 6 7 8 9 @ # \$ % & / ° ' ¢</p>	<p>NINE POINT. 1 2 3 4 5 6 7 8 9 @ # \$ % & / ° ' ¢</p>	<p>TEN POINT. 1 2 3 4 5 6 7 8 9 @ # \$ % & / ° ' ¢</p>
<p>ELEVEN POINT. 1 2 3 4 5 6 7 8 9 @ # \$ % & / ° ' ¢</p>	<p>TWELVE POINT. 1 2 3 4 5 6 7 8 9 @ # \$ % & / ° ' ¢</p>	

APOTHECARIES' SIGNS

FOR PRICES,
SEE COLUMN 1, PAGE 5

<p>FIVE POINT. 1 2 3 4 5 R ℞ 3 3 9</p>	<p>SIX POINT. 1 2 3 4 5 R ℞ 3 3 9</p>	<p>SEVEN POINT. 1 2 3 4 5 R ℞ 3 3 9</p>	<p>EIGHT POINT. 1 2 3 4 5 R ℞ 3 3 9</p>
<p>NINE POINT. 1 2 3 4 5 R ℞ 3 3 9</p>	<p>TEN POINT. 1 2 3 4 5 R ℞ 3 3 9</p>	<p>ELEVEN POINT. 1 2 3 4 5 R ℞ 3 3 9</p>	<p>TWELVE POINT. 1 2 3 4 5 R ℞ 3 3 9</p>

RECIPE MARKS

No. 1. 5½-POINT. R	No. 3. 7-POINT. R	No. 5. 9-POINT. R	No. 7. 11-POINT. R	No. 9. 14-POINT. R 5c.	No. 11. 24-POINT. R 10c.	No. 13. 36-POINT. R 15c.
No. 14. 48-POINT. R 20c.	No. 12. 30-POINT. R 10c.	No. 10. 18-POINT. R 5c.	No. 8. 12-POINT. R	No. 6. 10-POINT. R	No. 4. 8-POINT. R	No. 2. 6-POINT. R

NOS. 1 TO 5 AND 6 TO 8, IN SETS OF 4 EACH, 15c. PER SET.

PER CENT. MARKS

No. 1. 5½-POINT. %	No. 3. 7-POINT. %	No. 6. 10-POINT. %	No. 8. 12-POINT. %	No. 10. 16-POINT. % 5c.	No. 13. 28-POINT. % 15c.	No. 15. 48-POINT. % 20c.
No. 14. 36-POINT. % 15c.	No. 12. 22-POINT. % 10c.	No. 11. 18-POINT. % 10c.	No. 9. 14-POINT. % 5c.	No. 7. 11-POINT. %	No. 5. 9-POINT. %	No. 4. 8-POINT. %

NOS. 1 TO 5 AND 6 TO 8, IN SETS OF 4 EACH, 15c. PER SET.

CATALOGUE MARKS

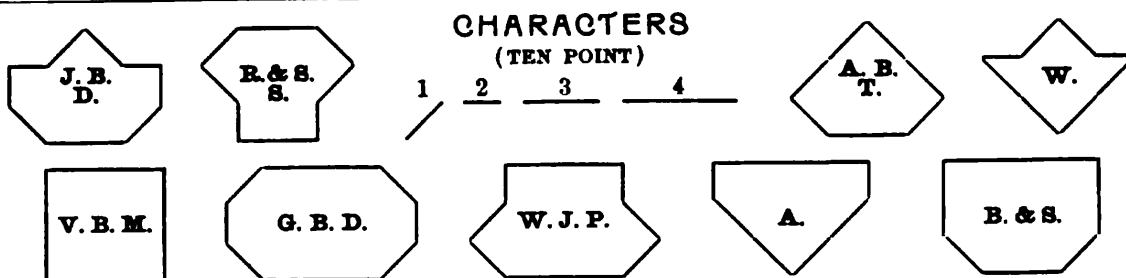

The Smallest Font contains: 44 each of Nos. 1 and 2; 22 of No. 3; 11 of No. 4
PER FONT, 75¢.

PIECE ACCENTS

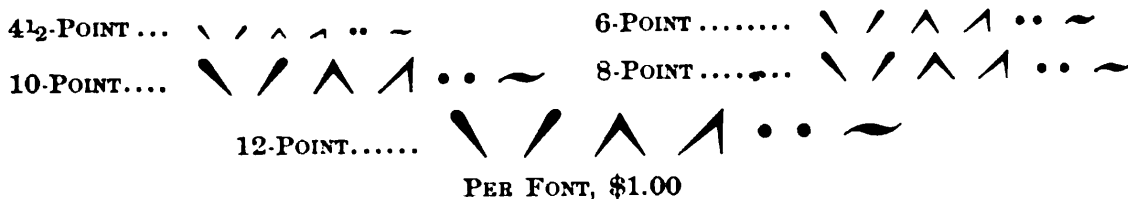

BRUCE TYPE FOUNDRY, 13 CHAMBERS STREET, NEW YORK.

ASTRONOMICAL SIGNS

FOR PRICES,
SEE COLUMN 3, PAGE 5

SIX POINT.

1	2	3	4	5	6	7	8	9	10	11	12	13	14	15	16	17	18	19
♈	♉	♊	♋	♌	♍	♎	♏	♐	♑	♒	♓	♈	♉	♊	♋	♌	♍	♎
			20	21	22	23	24	25	26	27	28	29	30	31	32			
			♈	♉	♊	♋	♌	♍	♎	♏	♐	♑	♒	♓	♈	♉	♊	♋

SEVEN POINT.

1	2	3	4	5	6	7	8	9	10	11	12	13	14	15	16	17	18	19
♈	♉	♊	♋	♌	♍	♎	♏	♐	♑	♒	♓	♈	♉	♊	♋	♌	♍	♎
			20	21	22	23	24	25	26	27	28	29	30	31	32			
			♈	♉	♊	♋	♌	♍	♎	♏	♐	♑	♒	♓	♈	♉	♊	♋

EIGHT POINT.

1	2	3	4	5	6	7	8	9	10	11	12	13	14	15	16	17	18	19
♈	♉	♊	♋	♌	♍	♎	♏	♐	♑	♒	♓	♈	♉	♊	♋	♌	♍	♎
			20	21	22	23	24	25	26	27	28	29	30	31	32			
			♈	♉	♊	♋	♌	♍	♎	♏	♐	♑	♒	♓	♈	♉	♊	♋

NINE POINT.

1	2	3	4	5	6	7	8	9	10	11	12	13	14	15	16	17	18	19
♈	♉	♊	♋	♌	♍	♎	♏	♐	♑	♒	♓	♈	♉	♊	♋	♌	♍	♎
			20	21	22	23	24	25	26	27	28	29	30	31	32			
			♈	♉	♊	♋	♌	♍	♎	♏	♐	♑	♒	♓	♈	♉	♊	♋

TEN POINT.

1	2	3	4	5	6	7	8	9	10	11	12	13	14	15	16	17	18	19
♈	♉	♊	♋	♌	♍	♎	♏	♐	♑	♒	♓	♈	♉	♊	♋	♌	♍	♎
			20	21	22	23	24	25	26	27	28	29	30	31	32			
			♈	♉	♊	♋	♌	♍	♎	♏	♐	♑	♒	♓	♈	♉	♊	♋

ELEVEN POINT.

1	2	3	4	5	6	7	8	9	10	11	12	13	14	15	16	17	18	19
♈	♉	♊	♋	♌	♍	♎	♏	♐	♑	♒	♓	♈	♉	♊	♋	♌	♍	♎
			20	21	22	23	24	25	26	27	28	29	30	31	32			
			♈	♉	♊	♋	♌	♍	♎	♏	♐	♑	♒	♓	♈	♉	♊	♋

TWELVE POINT.

1	2	3	4	5	6	7	8	9	10	11	12	13	14	15	16	17	18	19
♈	♉	♊	♋	♌	♍	♎	♏	♐	♑	♒	♓	♈	♉	♊	♋	♌	♍	♎
			20	21	22	23	24	25	26	27	28	29	30	31	32			
			♈	♉	♊	♋	♌	♍	♎	♏	♐	♑	♒	♓	♈	♉	♊	♋

TEN POINT, No. 2.

1	2	3	4	5	6	7	8	9	10	11	12	13	14	15	16

TWELVE POINT, No. 2.

1	2	3	4	5	6	7	8	9	10	11	12	13	14	15	16

SIXTEEN POINT.

1	2	3	4

TWENTY POINT.

1	2	3	4

TWENTY-FOUR POINT.

1	2	3	4

MATHEMATICAL SIGNS

FOR PRICES,
SEE COLUMN 3, PAGE 5

FIVE POINT.

1	2	3	4	5	6	7	8	9	10	11	12	13	14	15	16	17
+	-	×	÷	=	∠	∟	~	::	:	□	△	⊥	□		‡	≡
		18	19	20	21	22	23	24	25	26	27	28	29	30		
		±	▱	☉	○	∟	◦	'	#	≅	∴	√	√	↗		

FIVE-AND-A-HALF POINT.

1	2	3	4	5	6	7	8	9	10	11	12	13	14	15	16	17
+	-	×	÷	=	∠	∟	~	::	:	□	△	⊥	□		‡	≡
		18	19	20	21	22	23	24	25	26	27	28	29	30		
		±	▱	☉	○	∟	◦	'	≡	≅	∴	√	√	↗		

SIX POINT.

1	2	3	4	5	6	7	8	9	10	11	12	13	14	15	16	17
+	-	×	÷	=	∠	∟	~	::	:	□	△	⊥	□		‡	≡
		18	19	20	21	22	23	24	25	26	27	28	29	30		
		±	▱	☉	○	∟	◦	'	≡	≅	∴	√	√	↗		

SEVEN POINT.

1	2	3	4	5	6	7	8	9	10	11	12	13	14	15	16	17
+	-	×	÷	=	∠	∟	~	::	:	□	△	⊥	□		‡	≡
		18	19	20	21	22	23	24	25	26	27	28	29	30		
		±	▱	☉	○	∟	◦	'	≡	≅	∴	√	√	↗		

EIGHT POINT.

1	2	3	4	5	6	7	8	9	10	11	12	13	14	15	16	17
+	-	×	÷	=	∠	∟	~	::	:	□	△	⊥	□		‡	≡
		18	19	20	21	22	23	24	25	26	27	28	29	30		
		±	▱	☉	○	∟	◦	'	≡	≅	∴	√	√	↗		

NINE POINT.

1	2	3	4	5	6	7	8	9	10	11	12	13	14	15	16	17
+	-	×	÷	=	∠	∟	~	::	:	□	△	⊥	□		‡	≡
		18	19	20	21	22	23	24	25	26	27	28	29	30		
		±	▱	☉	○	∟	◦	'	≡	≅	∴	√	√	↗		

TEN POINT.

1	2	3	4	5	6	7	8	9	10	11	12	13	14	15	16	17
+	-	×	÷	=	∠	∟	~	::	:	□	△	⊥	□		‡	≡
		18	19	20	21	22	23	24	25	26	27	28	29	30		
		±	▱	☉	○	∟	◦	'	≡	≅	∴	√	√	↗		

ELEVEN POINT.

1	2	3	4	5	6	7	8	9	10	11	12	13	14	15	16	17
+	-	×	÷	=	∠	∟	~	::	:	□	△	⊥	□		‡	≡
		18	19	20	21	22	23	24	25	26	27	28	29	30		
		±	▱	☉	○	∟	◦	'	≡	≅	∴	√	√	↗		

TWELVE POINT.

1	2	3	4	5	6	7	8	9	10	11	12	13	14	15	16	17
+	-	×	÷	=	∠	∟	~	::	:	□	△	⊥	□		‡	≡
		18	19	20	21	22	23	24	25	26	27	28	29	30		
		±	▱	☉	○	∟	◦	'	≡	≅	∴	√	√	↗		

TEN POINT METAL BRACES

PRICE PER SET,
\$1.60.

A Set consists of one Brace
of each size.

THREE POINT BRACES

Set consists of four Braces
of each size.

PRICE PER SET,
\$1.00.

SPACE RULE

SEVEN POINT.....	- - - - -	Cast on 2½-Point body. \$1.50 per lb.
EIGHT POINT.....	- - - - -	
NINE POINT.....	- - - - -	
TEN POINT.....	- - - - -	
ELEVEN POINT.....	- - - - -	
TWELVE POINT.....	- - - - -	

METAL CORNER QUADS

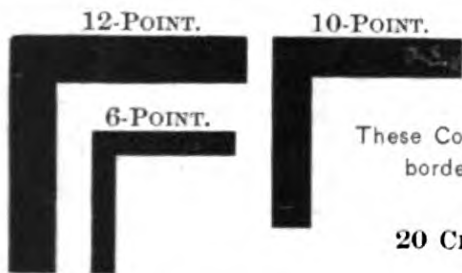

These Corner Quads, for use on rule
borders, insure perfect joints.

20 CENTS FOR SET OF FOUR.

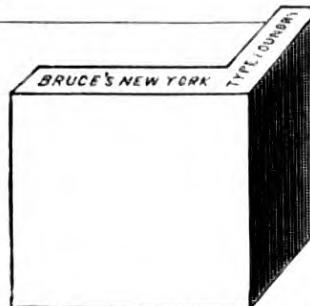

BRUCE TYPE FOUNDRY, 13 CHAMBERS STREET, NEW YORK.

CHESSMEN AND DRAUGHTS

TWENTY POINT CHESSMEN



THE
SMALLEST FONT OF CHESSMEN
CONTAINS

32 pieces of No. 1

2 pieces each of Nos. 2 to 11 and
14 to 23

6 pieces each of Nos. 12 and 13
and 24 and 25

Also Quads

PER FONT, \$4.80.

Brass Border for Chessmen,
25 cents extra

TWENTY POINT DRAUGHTS

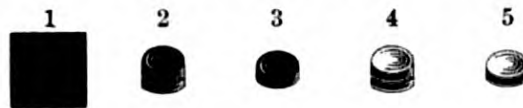

THE
SMALLEST FONT OF DRAUGHTS
CONTAINS

32 pieces of No. 1

6 pieces each of Nos. 2 and 4

12 pieces each of Nos. 3 and 5

Also Quads

PER FONT, \$4.80.

Brass Border for Draughts,
25 cents extra.

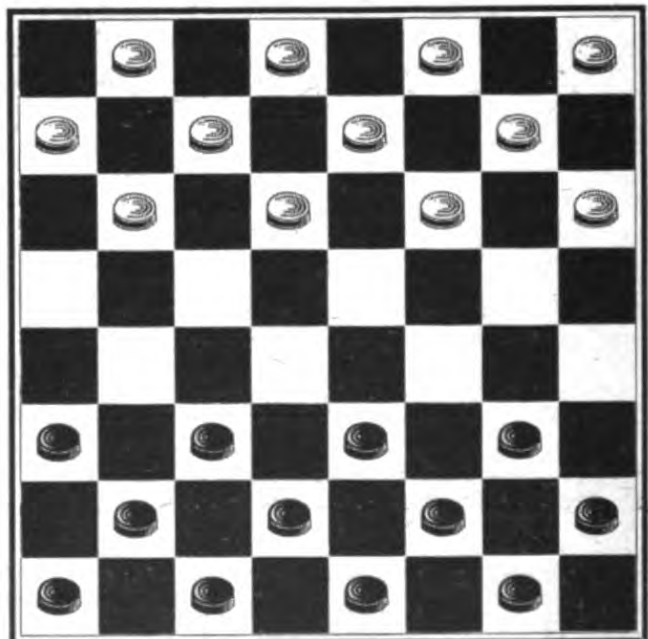

WE ALSO MAKE CHESSMEN AND DRAUGHTS ON 24-POINT BODY.

BRUCE TYPE FOUNDRY, 13 CHAMBERS STREET, NEW YORK.

ERASED

Ordered to be printed with the amendments of the Senate, viz.: Omit the parts struck through and insert that not cancelled.

14-POINT ERASED, No. 19.

3-NICK.

35 (5) ~~And hereafter no binding shall be done for~~
36 ~~any department of the government except in plain~~
37 ~~sheep or cloth, and no books shall be printed and~~
38 ~~bound except when the same shall be ordered by~~
39 ~~Congress or are provided by law.~~

40 (6) ~~And whenever any department shall re-~~
41 ~~quire any printing to be done, Government Printer~~
42 ~~shall furnish to such department a specification of~~
43 ~~the cost by items for said printing so called for; and~~

44 (7) That the sum of thirteen thousand dollars,
45 being the unexpended balance of the sum appro-
46 priated by act approved December fourteenth,
47 eighteen hundred -and seventy-seven, for printing
48 and binding for the Library of Congress, be, and
49 the same is hereby, reappropriated, and may be

50 Government Printing Office: For the construc-
51 tion of outside fire-escape ladders for the Govern-
52 ment Printing Office, three thousand dollars.

~~ABCDEFGHIJKLMN OPQRSTUVWXYZÆ&~~

~~ABCDEFGHIJKLMN OPQRSTUVWXYZÆ&~~

~~abcdefghijklmnopqrstu vwxyzæœffiffi.,;:'! ?-----~~

~~1234567890\$£~~

ERASED ITALIC

Ordered to be printed with the amendments of the Senate, viz.: Omit the parts struck through and insert that not cancelled.

14 POINT ERASED ITALIC, No. 19.

3-NICK.

35 ~~(5) And hereafter no binding shall be done~~
36 ~~for any department of the government except in~~
37 ~~plain sheep or cloth, and no books shall be printed~~
38 ~~and bound except when the same shall be~~
39 ~~ordered by Congress or are provided by law.~~

40 ~~(6) And whenever any department shall re-~~
41 ~~quire any printing to be done, Government Printer~~
42 ~~shall furnish to such department a specification of~~
43 ~~the cost by items for said printing so called for; and~~

44 (7) That the sum of thirteen thousand dollars,
45 being the unexpended balance of the sum appropri-
46 ated by act approved December fourteenth, eighteen
47 hundred and seventy-seven, for printing and bind-
48 ing for the Library of Congress, be, and the same is
49 hereby, reappropriated, and may be expended for

50 ~~Government Printing Office: For the con-~~
51 ~~struction of outside fire escape ladders for the Gov-~~
52 ~~ernment Printing Office, three thousand dollars.~~

~~ABCDEFGHIJKLMNOPQRSTUVWXYZÆ&~~

~~abcdefghijklmnopqrstuvwxyzæœfiffiffll.,:;-----~~

~~1234567890&£~~

BOOK AND NEWSPAPER FACES--MODERN

FOUR-AND-A-HALF POINT.

DIAMOND.

2-POINT LEADS USED THROUGHOUT.....

FOUR-AND-A-HALF POINT, No. 16.

2-NICK.

THE FIRST FOUNDEES had no common standard of height, thickness or other magnitude, and consequently the shape of the letters cut and cast by them differed very widely. It is easy in an old book to identify the type there used as having been employed in another book, and to state in what printing-office the work was prepared. To some extent the productions of two of the present foundries can still be told apart from all others, as there are differences which serve to mark them. The printers of the cradle age generally cast their own type and made their own punches. The letter were probably of brass or copper, and the matrices of lead. In the Enschedé foundry, in Haarlem, are leaden matrices, said to be derived from punches of copper. They are now over four hundred years old. The metal cast into them only touched them at the end of each type, and was chilled as soon as it touched the

leaden plate, leaving this intact. They were also obliged to make their own ink and construct their own presses. Type-founding seems to have been the first of the typographic processes which separated from the others and was carried on as a separate trade. Prior to this a printer was obliged to cut his own punches, fit up his matrices and do his own casting. It is true the number of characters employed with a certain size was small, not much exceeding one hundred; the type was large, thus obviating the necessity of so great an accuracy as was afterwards requisite, and few faces were necessary. Many printing-offices of the sixteenth century had only four or five sizes of type. The quantity required was also small. Enough for two quarto pages would do, if there were no more, and three or four cases full of type were amply sufficient. A printer could sometimes buy the stock of another who was declining business; he might induce a friend in another town to cast letter for him, and he could take some comparatively new characters of an old font, touch them up with a graver and employ them as punches for a new casting. Caxton did this. Some of the irregularity of old faces can thus be accounted for, as the letters, after being touched up, would give a duplicate, although slightly different from the original

ABCDEFGHIJKLMN O PQRSTU VWXYZ&#

ABCDEFGHIJKLMN O PQRSTU VWXYZ&#

Ⓢ 1234567890 & ½ ¼ ⅓ ⅔ ⅖ ⅘ ⅙ ⅛

PATENT FIGURES AND FRACTIONS—Ⓢ 1234567890 ½ ¼ ⅓ ⅔ ⅖ ⅘ ⅙ ⅛

The first foundries had no common standard of height, thickness or other magnitude, and consequently the shape of the letters cut and cast by them differed very widely. It is easy in an old book to identify the type there used as having

ABCDEFGHIJKLMN O PQRSTU VWXYZ&#

abcd efghijklmno pqrstuvwxy z

FIVE POINT.

PEARL.

FIVE POINT, No. 11.

2-NICK.

THE FIRST FOUNDEES had no common standard of height, thickness or other magnitude, and consequently the shape of the letters cut and cast by them differed very widely. It is easy in an old book to identify the type there used as having been employed in another book, and to state in what printing-office the work was prepared. To some extent the productions of two of the present foundries can still be told apart from all others, as there are differences which serve to mark them. The printers of the cradle age generally cast their own type and made their own punches. The letter were probably of brass or copper, and the matrices of lead. In the Enschedé foundry, in Haarlem, are leaden matrices, said to be derived from punches of copper. They are now over four hundred years old. The metal cast into them only touched them at the end of each type, and was chilled as soon as it touched the leaden plate, leaving this intact. They were also obliged to make their own ink and construct their own presses. Type-founding seems to have been the first of the typographic processes which separated from the others and was carried on as a separate trade. Prior to this a printer was obliged to cut his own punches, fit up his matrices and do his own casting. It is true the number of characters employed with a certain size was small, not much exceeding one hundred; the type was large, thus obviating

ABCDEFGHIJKLMN O PQRSTU VWXYZ&#

ABCDEFGHIJKLMN O PQRSTU VWXYZ&#

Ⓢ 1234567890 & ½ ¼ ⅓ ⅔ ⅖ ⅘ ⅙ ⅛

PATENT FIGURES AND FRACTIONS—Ⓢ 1234567890 ½ ¼ ⅓ ⅔ ⅖ ⅘ ⅙ ⅛

The first foundries had no common standard of height, thickness or other magnitude, and consequently the shape of the letters cut and cast by them differed very widely. It is easy in an old book to identify the

ABCDEFGHIJKLMN O PQRSTU VWXYZ&#

abcd efghijklmno pqrstuvwxy z

PROVERBS.

CHAPTER XII.

WHOSO loveth instruction loveth knowledge: but he that hateth reproof is brutish.

2 A good man obtaineth favour of the Lord: but a man of wicked devices will be condemn.

3 A man shall not be established by wickedness: but the root of the righteous shall not be moved.

4 A virtuous woman is a crown to her husband: but she that maketh ashamed is as rottenness in his bones.

CHAPTER XIII.

A WISE son heareth his father's instruction: but a scorner heareth not rebuke.

2 A man shall eat good by the fruit of his mouth: but the soul of the transgressors shall eat violence.

3 He that keepeth his mouth keepeth his life: but he that openeth wide his lips shall have destruction.

4 The soul of the sluggard desireth, and hath nothing: but the soul of the diligent shall be made fat.

BRUCE TYPE FOUNDRY, 13 CHAMBERS STREET, NEW YORK.

FIVE POINT.

PEARL.

FIVE POINT, No. 16.

2-NICK.

THE FIRST FOUNDERS had no common standard of height, thickness or other magnitude, and consequently the shape of the letters cut and cast by them differed very widely. It is easy in an old book to identify the type there used as having been used in another book, and to state in what printing-office the work was prepared. To some extent the productions of two of the present foundries can still be told apart from all others, as there are differences which serve to mark them. The printers of the cradle age generally cast their own type and made their own punches. The latter were probably of brass or copper, and the matrices of lead. In the Enschedé foundry, in Haarlem, are leaden matrices, said to be derived from punches of copper. They are now over four hundred years old. The metal cast into them only touched them at the end of each type, and was chilled as soon as it touched the leaden plate, leaving this intact. They were also obliged to make their own ink and construct their own presses. Type-founding seems to have been the first of the typographic processes which separated from the others and was carried on as a separate trade. Prior to this a printer was obliged to cut his own punches, fit up his matrices and do his own casting

ABCDEFGHIJKLMN OPQRSTUVWXYZÆ&

ABCDEFGHIJKLMN OPQRSTUVWXYZÆ&

§ 1234567890 & ½ ¼ ⅓ ⅔ ⅕ ⅖

PATENT FIGURES AND FRACTIONS—§ 1234567890 ½ ¼ ⅓ ⅔ ⅕ ⅖

The first founders had no common standard of height, thickness or other magnitude, and consequently the shape of the letters cut and cast by them differed very widely. It is easy in an old book to identify the type there used as

ABCDEFGHIJKLMN OPQRSTUVWXYZÆ&

abcdefghijklmno pqrstuvwxyz

I. SAMUEL.

CHAPTER XXIII.

THEN they told David, saying, Behold, the Philistines fight against Kellah, and they rob the threshing-floors.

¶ Therefore David inquired of the LORD, saying, Shall I go and smite these Philistines? And the LORD said unto David, Go, and smite the Philistines, and save Kellah.

CHAPTER XIV.

AND it came to pass, when Saul was returned from following the Philistines, that it was told him, saying, Behold, David is in the wilderness of Engedi.

¶ Then Saul took three thousand chosen men out of all Israel, and went to seek David and his men upon the rocks of the wild goats.

FIVE POINT, No. 21.

3-NICK.

THE FIRST FOUNDERS had no common standard of height, thickness or other magnitude, and consequently the shape of the letters cut and cast by them differed very widely. It is easy in an old book to identify the type there used as having been used in another book, and to state in what printing-office the work was prepared. To some extent the productions of two of the present foundries can still be told apart from all others, as there are differences which serve to mark them. The printers of the cradle age generally cast their own type and made their own punches. The latter were probably of brass or copper, and the matrices of lead. In the Enschedé foundry, in Haarlem, are leaden matrices, said to be derived from punches of copper. They are now over four hundred years old. The metal cast into them only touched them at the end of each type, and was chilled as soon as it touched the leaden plate, leaving this intact. They were also obliged to make their own ink and construct their own presses. Type-founding seems to have been the first of the typographic processes which separated from the others and was carried on as a separate trade. Prior to this a printer was obliged to cut his own punches, fit up his matrices and do his own casting. It is true the number of

ABCDEFGHIJKLMN OPQRSTUVWXYZÆ&

ABCDEFGHIJKLMN OPQRSTUVWXYZÆ&

§ 1234567890 & ½ ¼ ⅓ ⅔ ⅕ ⅖

PATENT FIGURES AND FRACTIONS—§ 1234567890 ½ ¼ ⅓ ⅔ ⅕ ⅖

The first founders had no common standard of height, thickness or other magnitude, and consequently the shape of the letters cut and cast by them differed very widely. It is easy in an old book to identify the type there used as

ABCDEFGHIJKLMN OPQRSTUVWXYZÆ&

abcdefghijklmno pqrstuvwxyz

DEUTERONOMY.

CHAPTER XIV.

YE are the children of the LORD your God: ye shall not cut yourselves, nor make any baldness between your eyes for the dead.

¶ For thou art a holy people unto the LORD thy God, and the LORD hath chosen thee to be a peculiar people unto himself, above all the nations that are upon the earth.

CHAPTER XV.

AT the end of every seven years thou shalt make a release.

¶ And this is the manner of the release: Every creditor that lendeth *ought* unto his neighbour, shall release it; he shall not exact it of his neighbor, or of his brother; because it is called the LORD's release.

BRUCE TYPE FOUNDRY, 13 CHAMBERS STREET, NEW YORK.

FIVE-AND-A-HALF POINT.

AGATE.

FIVE-AND-A-HALF POINT, No. 11.

2-NICK.

THE FIRST FOUNDERS had no common standard of height, thickness or other magnitude, and consequently the shape of the letters cut and cast by them differed very widely. It is easy in an old book to identify the type there used as having been employed in another book, and to state in what printing-office the work was prepared. To some extent the production of two of the present foundries can still be told apart from all others, as there are differences which serve to mark them. The printers of the cradle age generally cast their own type and made their own punches. The latter were probably of brass or copper, and the matrices of lead. In the Enschedé foundry, in Haarlem, are leaden matrices, said to be derived from punches of copper. They are now over four hundred years old. The metal cast into them only touched them at the end of each type, and was chilled as soon as it touched the leaden plate, leaving this intact. They were also obliged to make their own ink and construct their own presses. Type-founding seems to have been the first of the typographic processes which separated from the others and was carried on as a separate trade. Prior to this a printer was obliged to cut his own punches,

ABCDEFGHIJKLMN O PQRSTU VWXYZÆ&

ABCDEFGHIJKLMN O PQRSTU VWXYZÆ&

§ 1234567890 & ¶¶¶¶¶¶¶¶ ¶ ½ ¼ ⅓ ⅔ ⅕ ⅖ ⅗

PATENT FIGURES AND FRACTIONS—§ 1234567890 ½ ¼ ⅓ ⅔ ⅕ ⅖ ⅗

The first founders had no common standard of height, thickness or other magnitude, and consequently the shape of the letters cut and cast by them differed very widely. It is easy in an old book to identify

ABCDEFGHIJKLMN O PQRSTU VWXYZÆ&

abcdefghijklmnopqrstu vwxyz

No. 11.

THE FIRST FOUNDERS had no common standard of height, thickness or other magnitude, and consequently the shape of the letters cut and cast by them differed very widely. It is easy in an old book to identify the type there used as having been employed in another book, and to state in what printing-office the work was prepared. To some extent the productions of two of the present foundries can still be told apart from all others, as there are differences which serve to mark them. The printers of the cradle age generally cast their own type and made their own punches. The latter were probably of brass or copper, and the matrices of lead. In the Enschedé foundry, in Haarlem, are

No. 12.

THE FIRST FOUNDERS had no common standard of height, thickness or other dimensions, and consequently the shape of the letters cut and cast by them differed very widely. It is easy in an old book to identify the type there used as having been employed in another book, and to state in what printing-office the work was prepared. To some extent the productions of two of the present foundries can still be told apart from all others, as there are differences which serve to mark them. The printers of the cradle age generally cast their own type and made their own punches. The latter were probably of brass or copper, and the matrices of lead. In the Enschedé foundry, in Haarlem, are leaden matrices, said to be derived from punches of copper. They are now over four hundred years old. The metal cast into them only touched them at the end of each type, and was chilled as soon as it touched

FIVE-AND-A-HALF POINT, No. 12.

2-NICK.

THE FIRST FOUNDERS had no common standard of height, thickness or other magnitude, and consequently the shape of the letters cut and cast by them differed very widely. It is easy in an old book to identify the type there used as having been employed in another book, and to state in what printing-office the work was prepared. To some extent the productions of two of the present foundries can still be told apart from all others, as there are differences which serve to mark them. The printers of the cradle age generally cast their own type and made their own punches. The latter were probably of brass or copper, and the matrices of lead. In the Enschedé foundry, in Haarlem, are leaden matrices, said to be derived from punches of copper. They are now over four hundred years old. The metal cast into them only touched them at the end of each type, and was chilled as soon as it touched the leaden plate, leaving this intact. They were also obliged to make their own ink and construct their own presses. Type-founding seems to have been the first of the

ABCDEFGHIJKLMN O PQRSTU VWXYZÆ&

ABCDEFGHIJKLMN O PQRSTU VWXYZÆ&

§ 1234567890 ¶¶¶¶¶¶¶¶ ¶ ½ ¼ ⅓ ⅔ ⅕ ⅖ ⅗

PATENT FIGURES AND FRACTIONS—§ 1234567890 ½ ¼ ⅓ ⅔ ⅕ ⅖ ⅗

The first founders had no common standard of height, thickness or other magnitude, and consequently the shape of the letters cut and cast by them differed very widely. It

ABCDEFGHIJKLMN O PQRSTU VWXYZÆ&

abcdefghijklmnopqrstu vwxyz

V. B. MUNSON, SUCCESSOR TO

GEO. BRUCE'S SON & CO., 13 CHAMBERS STREET, NEW YORK.

FIVE-AND-A-HALF POINT.

AGATE.

FIVE-AND-A-HALF POINT, No. 13.

2-NICK.

THE FIRST FOUNDERS had no common standard of height, thickness or other magnitude, and consequently the shape of the letters cut and cast by them differed very widely. It is easy in an old book to identify the type there used as having been employed in another book, and to state in what printing-office the work was prepared. To some extent the productions of two of the present foundries can still be told apart from all others, as there are differences which serve to mark them. The printers of the cradle age generally cast their own type and made their own punches. The latter were probably of brass or copper, and the matrices of lead. In the Enschedé foundry, in Haarlem, are leaden matrices, said to be derived from punches of copper. They are now over four hundred years old. The metal cast into them only touched them at the end of each type, and was chilled as soon as it touched the leaden plate, leaving this intact. They were also obliged to make their own ink and construct their own presses. Type-founding seems to have been the first of the typographic processes which

ABCDEFGHIJKLMN OPQRSTUVWXYZÆ&

ABCDEFGHIJKLMN OPQRSTUVWXYZÆ&

§ 1234567890 £ 1111111111 ½ ¼ ⅓ ⅔ ⅕ ⅙ ⅚

PATENT FIGURES AND FRACTIONS—§ 1234567890 ½ ¼ ⅓ ⅔ ⅕ ⅙ ⅚

The first founders had no common standard of height, thickness or other magnitude, and consequently the shape of the letters cut and cast by them differed very widely. It is easy in an old

ABCDEFGHIJKLMN OPQRSTUVWXYZÆ&

abcdefghijklmnopqrstuvwxyz

No. 13.

THE FIRST FOUNDERS had no common standard of height, thickness or other magnitude, and consequently the shape of the letters cut and cast by them differed very widely. It is easy in an old book to identify the type there used as having been employed in another book, and to state in what printing-office the work was prepared. To some extent the productions of two of the present foundries can still be told apart from all others, as there are differences which serve to mark them. The printers of the cradle age generally cast their own type and made their own punches. The latter were probably of brass or copper, and the matrices of lead. In the Enschedé foundry, in Haarlem, are leaden matrices, said to be derived from punches of copper. They are now over four hundred years old. The metal cast into them only touched them at the end of each type, and was chilled as soon as it touched the leaden

No. 14.

THE FIRST FOUNDERS had no common standard of height, thickness or other magnitude, and consequently the shape of the letters cut and cast by them differed very widely. It is easy in an old book to identify the type there used as having been employed in another book, and to state in what printing-office the work was prepared. To some extent the productions of two of the present foundries can still be told apart from all others, as there are differences which serve to mark them. The printers of the cradle age generally cast their own type and made their own punches. The latter were probably of brass or copper, and the matrices of lead. In the Enschedé foundry, in Haarlem, are leaden ma-

FIVE-AND-A-HALF POINT, No. 14.

2-NICK.

THE FIRST FOUNDERS had no common standard of height, thickness or other magnitude, and consequently the shape of the letters cut and cast by them differed very widely. It is easy in an old book to identify the type there used as having been employed in another book, and to state in what printing-office the work was prepared. To some extent the productions of two of the present foundries can still be told apart from all others, as there are differences which serve to mark them. The printers of the cradle age generally cast their own type and made their own punches. The latter were probably of brass or copper, and the matrices of lead. In the Enschedé foundry, in Haarlem, are leaden matrices, said to be derived from punches of copper. They are now over four hundred years old. The metal cast into them only touched them at the end of each type, and was chilled as soon as it touched the leaden plate, leaving this intact. They were also obliged to make their own ink and construct their own presses. Type-founding seems to have been the first of the typographic processes which separated from the others and was carried on as a separate trade. Prior to this a printer was obliged to cut his own punches, fit up his matrices and

ABCDEFGHIJKLMN OPQRSTUVWXYZÆ&

ABCDEFGHIJKLMN OPQRSTUVWXYZÆ&

§ 1234567890 £ 1111111111 ½ ¼ ⅓ ⅔ ⅕ ⅙ ⅚

PATENT FIGURES AND FRACTIONS—§ 1234567890 ½ ¼ ⅓ ⅔ ⅕ ⅙ ⅚

The first founders had no common standard of height, thickness or other magnitude, and consequently the shape of the letters cut and cast by them differed very widely. It is easy in an old

ABCDEFGHIJKLMN OPQRSTUVWXYZÆ&

abcdefghijklmnopqrstuvwxyz

V. B. MUNSON, SUCCESSOR TO

GEO. BRUCE'S SON & CO., 13 CHAMBERS STREET, NEW YORK.

FIVE-AND-A-HALF POINT.

AGATE.

FIVE-AND-A-HALF POINT, No. 15.

2-NICK.

THE FIRST FOUNDERS had no common standard of height, thickness or other magnitude, and consequently the shape of the letters cut and cast by them differed very widely. It is easy in an old book to identify the type there used as having been employed in another book, and to state in what printing-office the work was prepared. To some extent the productions of two of the present foundries can still be told apart from all the others, as there are differences which serve to mark them. The printers of the cradle age generally cast their own type and made their own punches. The latter were probably of brass or copper, and the matrices of lead. In the Enschedé foundry, in Haarlem, are leaden matrices, said to be derived from punches of copper. They are now over four hundred years old. The metal cast into them only touched them at the end of each type, and was chilled as soon as it touched the leaden plate, leaving this intact. They were also obliged to make their own ink and construct their own presses. Type-founding seems to have been the first of the typographic processes which separated from the others and was carried on as a separate trade. Prior to this a printer was obliged to cut his own punches, fit up his matrices and do his own casting. It is true the number of characters

ABCDEFGHIJKLMN OPQRSTUVWXYZÆ&

ABCDEFGHIJKLMN OPQRSTUVWXYZÆ&

§ 1234567890 £ 11111111 ½ ¼ ⅓ ⅔ ⅕ ⅖ ⅗ ⅘

PATENT FIGURES AND FRACTIONS—§ 1234567890 ½ ¼ ⅓ ⅔ ⅕ ⅖ ⅗ ⅘

The first founders had no common standard of height, thickness or other magnitude, and consequently the shape of the letters cut and cast by them differed very widely. It is easy in an old book to identify

ABCDEFGHIJKLMN OPQRSTUVWXYZÆ&

abcdefghijklmno pqrstuvwxyz

No. 15.

THE FIRST FOUNDERS had no common standard of height, thickness or other magnitude, and consequently the shape of the letters cut and cast by them differed very widely. It is easy in an old book to identify the type there used as having been employed in another book, and to state in what printing-office the work was prepared. To some extent the productions of two of the present foundries can still be told apart from all others, as there are differences which serve to mark them. The printers of the cradle age generally cast their own type and made their own punches. The latter were probably of brass or copper, and the matrices of lead. In the Enschedé foundry, in Haarlem, are leaden matrices, said to be derived from

No. 21.

THE FIRST FOUNDERS had no common standard of height, thickness or other magnitude, and consequently the shape of the letters cut and cast by them differed very widely. It is easy in an old book to identify the type there used as having been employed in another book, and to state in what printing-office the work was prepared. To some extent the productions of two of the present foundries can still be told apart from all others, as there are differences which serve to mark them. The printers of the cradle age generally cast their own type and made their own punches. The latter were probably of brass or copper, and the matrices of lead. In the Enschedé foundry, in Haarlem, are leaden matrices, said to be derived from punches of copper. They are now over four hundred years old. The metal cast into them only touched them at the end of each type, and was chilled as soon as it touched the leaden plate, leaving this intact. They were also

FIVE-AND-A-HALF POINT, No. 21.

3-NICK.

THE FIRST FOUNDERS had no common standard of height, thickness or other magnitude, and consequently the shape of the letters cut and cast by them differed very widely. It is easy in an old book to identify the type there used as having been employed in another book, and to state in what printing-office the work was prepared. To some extent the productions of two of the present foundries can still be told apart from all others, as there are differences which serve to mark them. The printers of the cradle age generally cast their own type and made their own punches. The latter were probably of brass or copper, and the matrices of lead. In the Enschedé foundry, in Haarlem, are leaden matrices, said to be derived from punches of copper. They are now over four hundred years old. The metal cast into them only touched them at the end of each type, and was chilled as soon as it touched the leaden plate, leaving this intact. They were also obliged to make their own ink and construct their own presses. Type-founding seems to have been the first of the typographic processes which separated from the others and was carried on as a separate trade. Prior to this

ABCDEFGHIJKLMN OPQRSTUVWXYZÆ&

ABCDEFGHIJKLMN OPQRSTUVWXYZÆ&

§ 1234567890 £ 11111111 ½ ¼ ⅓ ⅔ ⅕ ⅖ ⅗ ⅘

PATENT FIGURES AND FRACTIONS—§ 1234567890 ½ ¼ ⅓ ⅔ ⅕ ⅖ ⅗ ⅘

The first founders had no common standard of height, thickness or other magnitude, and consequently the shape of the letters cut and cast by them differed very widely. It is easy in an old book to identify

ABCDEFGHIJKLMN OPQRSTUVWXYZÆ&

abcdefghijklmno pqrstuvwxyz

V. B. MUNSON, SUCCESSOR TO

GEO. BRUCE'S SON & CO., 13 CHAMBERS STREET, NEW YORK.

SIX POINT.

NONPAREIL.

SIX POINT, No. 11.

3-NICK.

THE FIRST FOUNDERS had no common standard of height, thickness or other magnitude, and consequently the shape of the letters cut and cast by them differed very widely. It is easy in an old book to identify the type there used as having been employed in another book, and to state in what printing-office the work was prepared. To some extent the productions of two of the present foundries can still be told apart from all others, as there are differences which serve to mark them. The printers of the cradle age generally cast their own type and made their own punches. The latter were probably of brass or copper, and the matrices of lead. In the Enschedé foundry, in Haarlem, are leaden matrices, said to be derived from punches of copper. They are now over four hundred years old. The metal cast into them only touched them at the end of each type, and was chilled as soon as it touched the leaden plate, leaving this intact. They were also obliged to make their own ink and construct their own presses. Type-founding seems to have been the

ABCDEFGHIJKLMN OPQRSTUVWXYZÆ&

ABCDEFGHIJKLMN OPQRSTUVWXYZÆ

\$ 1234567890 & ¶¶¶¶¶¶¶¶ ½¼⅓⅔¼⅓⅔

PATENT FIGURES AND FRACTIONS—\$ 1234567890 ½¼⅓¼⅓⅔

The first founders had no common standard of height, thickness or other magnitude, and consequently the shape of the letters cut and cast by them differed very widely. It is easy

ABCDEFGHIJKLMN OPQRSTUVWXYZÆ&

abcdefghijklmnopqrstuvwxy

No. 11.

THE FIRST FOUNDERS had no common standard of height, thickness or other magnitude, and consequently the shape of the letters cut and cast by them differed very widely. It is easy in an old book to identify the type there used as having been employed in another book, and to state in what printing-office the work was prepared. To some extent the productions of two of the present foundries can still be told apart from all others, as there are differences which serve to mark them. The printers of the cradle age generally cast their own type and made their own punches. The latter were pro-

No. 12.

THE FIRST FOUNDERS had no common standard of height, thickness or other magnitude, and consequently the shape of the letters cut and cast by them differed very widely. It is easy in an old book to identify the type there used as having been employed in another book, and to state in what printing-office the work was prepared. To some extent the productions of two of the present foundries can still be told apart from all others, as there are differences which serve to mark them. The printers of the cradle age generally cast their own type and made their own punches. The latter were probably of brass or copper, and the matrices of lead. In the Enschedé foundry, in Haarlem, are leaden matrices, said to be derived

SIX POINT, No. 12.

3-NICK.

THE FIRST FOUNDERS had no common standard of height, thickness or other magnitude, and consequently the shape of the letters cut and cast by them differed very widely. It is easy in an old book to identify the type there used as having been employed in another book, and to state in what printing-office the work was prepared. To some extent the productions of two of the present foundries can still be told apart from all others, as there are differences which serve to mark them. The printers of the cradle age generally cast their own type and made their own punches. The latter were probably of brass or copper, and the matrices of lead. In the Enschedé foundry, in Haarlem, are leaden matrices, said to be derived from punches of copper. They are now over four hundred years old. The metal cast into them only touched them at the end of each type, and was chilled as

ABCDEFGHIJKLMN OPQRSTUVWXYZÆ&

ABCDEFGHIJKLMN OPQRSTUVWXYZÆ

\$ 1234567890 & ¶¶¶¶¶¶¶¶ ½¼⅓⅔¼⅓⅔

PATENT FIGURES AND FRACTIONS—\$ 1234567890 ½¼⅓¼⅓⅔

The first founders had no common standard of height, thickness or other magnitude, and consequently the shape of the letters cut and cast by them differed very

ABCDEFGHIJKLMN OPQRSTUVWXYZÆ&

abcdefghijklmnopqrstuvwxy

V. B. MUNSON, SUCCESSOR TO

GEO. BRUCE'S SON & CO., 13 CHAMBERS STREET, NEW YORK.

SIX POINT.

NONPAREIL.

SIX POINT, No. 13.

3-NICK.

THE FIRST FOUNDERS had no common standard of height, thickness or other magnitude, and consequently the shape of the letters cut and cast by them differed very widely. It is easy in an old book to identify the type there used as having been employed in another book, and to state in what printing-office the work was prepared. To some extent the productions of two of the present foundries can still be told apart from all others, as there are differences

which serve to mark them. The printers of the cradle age generally cast their own type and made their own punches. The latter were probably of brass or copper, and the matrices of lead. In the Enschedé foundry, in Haarlem, are leaden matrices, said to be derived from punches of copper. They are now over four hundred years old. The metal cast into them only touched them at the end of each type, and was chilled as soon as it touched the leaden plate, leaving this intact. They were also obliged to make their own ink and construct their own presses. Type-founding

ABCDEFGHIJKLMN OPQRSTUVWXYZÆ&

ABCDEFGHIJKLMN OPQRSTUVWXYZÆ&

\$ 1234567890 & ¶¶¶¶¶¶¶¶ ¶½¼¼¼¾¾¾¾¾¾

PATENT FIGURES AND FRACTIONS—\$ 1234567890 ½¼¼¼¼¾¾¾¾¾¾

The first founders had no common standard of height, thickness or other magnitude, and consequently the shape of the letters cut and cast by them differed very widely. It

ABCDEFGHIJKLMN OPQRSTUVWXYZÆ&

abcdefghijklmnopqrstuvwxyz

SIX POINT, No. 14.

3-NICK.

THE FIRST FOUNDERS had no common standard of height, thickness or other magnitude, and consequently the shape of the letters cut and cast by them differed very widely. It is easy in an old book to identify the type there used as having been employed in another book, and to state in what printing-office the work was prepared. To some extent the productions of two of the present foundries can still be told apart from all others, as there are differences which serve to mark them. The printers of the cradle age generally cast their own type and made their own punches. The latter were probably of brass or copper, and the matrices of lead. In the Enschedé foundry, in Haarlem, are leaden matrices, said to be derived from punches of copper. They are now over four hundred years old. The metal cast into them only touched them at the end of each type, and was chilled as soon as it touched

ABCDEFGHIJKLMN OPQRSTUVWXYZÆ&

ABCDEFGHIJKLMN OPQRSTUVWXYZÆ&

\$ 1234567890 & ¶¶¶¶¶¶¶¶ ¶½¼¼¼¾¾¾¾¾¾

PATENT FIGURES AND FRACTIONS—\$ 1234567890 ½¼¼¼¼¾¾¾¾¾¾

The first founders had no common standard of height, thickness or other magnitude, and consequently the shape of the letters cut and cast by them differed very widely. It is easy

ABCDEFGHIJKLMN OPQRSTUVWXYZÆ&

abcdefghijklmnopqrstuvwxyz

SIX POINT, No. 15.

3-NICK.

THE FIRST FOUNDERS had no common standard of height, thickness or other magnitude, and consequently the shape of the letters cut and cast by them differed very widely. It is easy in an old book to identify the type there used as having been employed in another book, and to state in what printing-office the work was prepared. To some extent the productions of two of the present foundries can still be told apart from all others, as there are differences which serve to mark them. The printers of the cradle age generally cast their own type and made their own punches. The latter were probably of brass or

copper, and the matrices of lead. In the Enschedé foundry, in Haarlem, are leaden matrices, said to be derived from punches of copper. They are now over four hundred years old. The metal cast into them only touched them at the end of each type, and was chilled as soon as it touched the leaden plate, leaving this intact. They were also obliged to make their own ink and construct their own presses. Type-founding seems to have been the first of the typographic processes which

ABCDEFGHIJKLMN OPQRSTUVWXYZÆ&

ABCDEFGHIJKLMN OPQRSTUVWXYZÆ&

\$ 1234567890 & ¶¶¶¶¶¶¶¶ ¶½¼¼¼¾¾¾¾¾¾

PATENT FIGURES AND FRACTIONS—\$ 1234567890 ½¼¼¼¼¾¾¾¾¾¾

The first founders had no common standard of height, thickness or other magnitude, and consequently the shape of the letters cut and cast by them differed very widely. It is easy in an

ABCDEFGHIJKLMN OPQRSTUVWXYZÆ&

abcdefghijklmnopqrstuvwxyz

V. B. MUNSON, SUCCESSOR TO
GEO. BRUCE'S SON & CO., 13 CHAMBERS STREET, NEW YORK.

SIX POINT.

NONPAREIL.

SIX POINT, NO. 16.

2-NICK.

THE FIRST FOUNDERS had no common standard of height, thickness or other magnitude, and consequently the shape of the letters cut and cast by them differed very widely. It is easy in an old book to identify the type there used as having been employed in another book, and to state in what printing-office the work was prepared. To some extent the productions of two of the present foundries can still be told apart from all others, as there are differences which serve to mark them. The printers of the cradle age generally cast their own type and made their own punches. The latter were probably of brass or copper, and the matrices of lead. In the Enschedé foundry, in Haarlem, are leaden matrices, said to be derived from punches of copper. They are now over four hundred years old. The metal cast into them only touched them at the end of each type, and was chilled as soon as it touched the leaden plate, leaving this intact. They were also obliged to make their own ink and construct their own presses. Type-founding

ABCDEFGHIJKLMN O PQRSTU VWXYZÆ&

ABCDEFGHIJKLMN O PQRSTU VWXYZÆ&

§ 1234567890 £ 11111111 ½¼⅓⅔¼⅕⅙⅑

PATENT FIGURES AND FRACTIONS—§ 1234567890 1₂1₃1₄1₈2₃3₄3₈5₈7₈

The first founders had no common standard of height, thickness or other magnitude, and consequently the shape of the letters cut and cast by them differed very widely. It is easy in an

ABCDEFGHIJKLMN O PQRSTU VWXYZÆ&

abcdefghijklmnopqrstu vwxyz

No. 16.

THE FIRST FOUNDERS had no common standard of height, thickness or other magnitude, and consequently the shape of the letters cut and cast by them differed very widely. It is easy in an old book to identify the type there used as having been employed in another book, and to state in what printing-office the work was prepared. To some extent the productions of two of the present foundries can still be told apart from all others, as there are differences which serve to mark them. The printers of the cradle age generally cast their own type and made their own punches. The latter were probably of brass or copper, and the matrices of lead. In the Enschedé foundry, in Haarlem, are leaden matrices, said to be derived from punches of copper. They are now over four hundred years old. The metal cast into them only touched them at the end

No. 21.

THE FIRST FOUNDERS had no common standard of height, thickness or other magnitude, and consequently the shape of the letters cut and cast by them differed very widely. It is easy in an old book to identify the type there used as having been employed in another book, and to state in what printing-office the work was prepared. To some extent the productions of two of the present foundries can still be told apart from all others, as there are differences which serve to mark them. The printers of the cradle age generally cast their own type and made their own punches. The latter were probably of brass or

SIX POINT, No. 21.

2-NICK.

THE FIRST FOUNDERS had no common standard of height, thickness or other magnitude, and consequently the shape of the letters cut and cast by them differed very widely. It is easy in an old book to identify the type there used as having been employed in another book, and to state in what printing-office the work was prepared. To some extent the productions of two of the present foundries can still be told apart from all others, as there are differences which serve to mark them. Printers of the cradle age generally cast their own type and made their own punches. The latter were probably of brass or copper, and the matrices of lead. In the Enschedé foundry, in Haarlem, are leaden matrices, said to be derived from punches of copper. They are now over four hundred years old. The metal cast into them only touched them at the end of each type, and was chilled as soon as it touched the leaden plate, leaving this intact. They were also obliged to make their own ink and construct their own presses. Type-founding seems to have been the first of the typographic pro-

ABCDEFGHIJKLMN O PQRSTU VWXYZÆ&

ABCDEFGHIJKLMN O PQRSTU VWXYZÆ&

§ 1234567890 £ 11111111 ½¼⅓⅔¼⅕⅙⅑

PATENT FIGURES AND FRACTIONS—§ 1234567890 1₂1₃1₄1₈2₃3₄3₈5₈7₈

The first founders had no common standard of height, thickness or other magnitude, and consequently the shape of the letters cut and cast by them differed very widely. It is easy in an

ABCDEFGHIJKLMN O PQRSTU VWXYZÆ&

abcdefghijklmnopqrstu vwxyz

V. B. MUNSON, SUCCESSOR TO
GEO. BRUCE'S SON & CO., 13 CHAMBERS STREET, NEW YORK.

SEVEN POINT.

MINTON.

SEVEN POINT, No. 11.

2-NICK.

THE FIRST FOUNDERS had no common standard of height, thickness or other magnitude, and consequently the shape of the letters cut and cast by them differed very widely. It is easy in an old book to identify the type there used as having been employed in another book, and to state in what printing-office the work was prepared. To some extent the productions of two of the present foundries can still be told apart from all others, as there are differences which serve to mark them. The printers of the cradle age generally cast their own type and made their own punches. The latter were probably of brass or copper, and the matrices of lead. In the Enschedé foundry, in Haarlem, are leaden matrices, said to be derived from punches of copper. They are now over four hundred years old. The metal cast into them only touched them at the end of each type, and was chilled as soon as it touched the leaden plate, leaving this intact. They were also obliged to make their own ink and construct their own presses. Type-founding seems to have been the first of the typographic processes which separated from the others and was carried on as a separate trade. Prior to this a printer was obliged to cut his own punches, fit up his matrices and do his own casting. It is true the number of characters employed with a certain size was small, not much exceeding one hundred; the type was

ABCDEFGHIJKLMNOPQRSTUVWXYZÆ&

ABCDEFGHIJKLMNOPQRSTUVWXYZÆ

§ 1234567890 £ ||||| ½ ⅓ ¼ ⅕ ⅙ ⅚ ⅞ ⅛

PATENT FIGURES AND FRACTIONS—\$ 1234567890 ½ ⅓ ¼ ⅕ ⅙ ⅚ ⅞ ⅛

The first founders had no common standard of height, thickness or other magnitude, and consequently the shape of the letters cut and cast by them differed very widely.

ABCDEFGHIJKLMNOPQRSTUVWXYZÆ&

abcdefghijklmnopqrstuvwxy

SEVEN POINT, No. 12.

2-NICK.

THE FIRST FOUNDERS had no common standard of height, thickness or other magnitude, and consequently the shape of the letters cut and cast by them differed very widely. It is easy in an old book to identify the type there used as having been employed in another book, and to state in what printing-office the work was prepared. To some extent the productions of two of the present foundries can still be told apart from all others, as there are differences which serve to mark them. The printers of the cradle age generally cast their own type and made their own punches. The latter were probably of brass or copper, and the matrices of lead. In the Enschedé foundry, in Haarlem, are leaden matrices, said to be derived from punches of copper. They are now over four hundred years old. The metal cast into them only touched them at the end of each type, and was chilled as soon as it touched the leaden plate, leaving this intact. They were also obliged to make their own ink and construct their own presses. Type-founding seems to have been the first of the typographic processes which separated from the others and was carried on as a separate trade. Prior to this a printer was obliged to cut his own punches, fit up his matrices and do

ABCDEFGHIJKLMNOPQRSTUVWXYZÆ&

ABCDEFGHIJKLMNOPQRSTUVWXYZÆ

§ 1234567890 £ ||||| ½ ⅓ ¼ ⅕ ⅙ ⅚ ⅞ ⅛

PATENT FIGURES AND FRACTIONS—\$ 1234567890 ½ ⅓ ¼ ⅕ ⅙ ⅚ ⅞ ⅛

The first founders had no common standard of height, thickness or other magnitude, and consequently the shape of the letters cut and cast by them differed

ABCDEFGHIJKLMNOPQRSTUVWXYZÆ&

abcdefghijklmnopqrstuvwxy

V. B. MUNSON, SUCCESSOR TO
GEO. BRUCE'S SON & CO., 13 CHAMBERS STREET, NEW YORK.

SEVEN POINT.

MINION.

SEVEN POINT, No. 13.

2-NICK.

THE FIRST FOUNDERS had no common standard of height, thickness or other magnitude, and consequently the shape of the letters cut and cast by them differed very widely. It is easy in an old book to identify the type there used as having been employed in another book, and to state in what printing-office the work was prepared. To some extent the productions of two of the present foundries can still be told apart from all others, as there are differences which serve to mark them. The printers of the cradle age generally cast their own type and made their own punches. The latter

ABCDEFGHIJKLMN OPQRSTUVWXYZÆ&

ABCDEFGHIJKLMN OPQRSTUVWXYZÆ

§ 1234567890 £ 1111111111 1/2 1/3 1/4 1/8 2/3 3/4 3/8 5/8 7/8

PATENT FIGURES AND FRACTIONS—§ 1234567890 1/2 1/3 1/4 1/8 2/3 3/4 3/8 5/8 7/8

The first founders had no common standard of height, thickness or other magnitude, and consequently the shape of the letters cut and cast by them differed very

ABCDEFGHIJKLMN OPQRSTUVWXYZÆ&

abcdefghijklmnopqrstuvwxyz

SEVEN POINT, No. 14.

2-NICK.

THE FIRST FOUNDERS had no common standard of height, thickness or other magnitude, and consequently the shape of the letters cut and cast by them differed very widely. It is easy in an old book to identify the type there used as having been employed in another book, and to state in what printing-office the work was prepared. To some extent the productions of two of the present foundries can still be told apart from all others, as there are differences which serve to mark them. The printers of the cradle age generally cast their own type and made their own punches. The latter were probably of brass or

ABCDEFGHIJKLMN OPQRSTUVWXYZÆ&

ABCDEFGHIJKLMN OPQRSTUVWXYZÆ

§ 1234567890 £ 1111111111 1/2 1/3 1/4 1/8 2/3 3/4 3/8 5/8 7/8

PATENT FIGURES AND FRACTIONS—§ 1234567890 1/2 1/3 1/4 1/8 2/3 3/4 3/8 5/8 7/8

The first founders had no common standard of height, thickness or other magnitude, and consequently the shape of the letters cut and cast by them differed very

ABCDEFGHIJKLMN OPQRSTUVWXYZÆ&

abcdefghijklmnopqrstuvwxyz

SEVEN POINT, No. 15.

2-NICK.

THE FIRST FOUNDERS had no common standard of height, thickness or other magnitude, and consequently the shape of the letters cut and cast by them differed very widely. It is easy in an old book to identify the type there used as having been employed in another book, and to state in what printing-office the work was prepared. To some extent the productions of two of the present foundries can still be told apart from all others, as there are differences which serve to mark them. The printers of the cradle age generally cast their own type and made their own punches. The latter were probably of brass or copper,

ABCDEFGHIJKLMN OPQRSTUVWXYZÆ&

ABCDEFGHIJKLMN OPQRSTUVWXYZÆ

§ 1234567890 £ 1111111111 1/2 1/3 1/4 1/8 2/3 3/4 3/8 5/8 7/8

PATENT FIGURES AND FRACTIONS—§ 1234567890 1/2 1/3 1/4 1/8 2/3 3/4 3/8 5/8 7/8

The first founders had no common standard of height, thickness or other magnitude, and consequently the shape of the letters cut and cast by them differed

ABCDEFGHIJKLMN OPQRSTUVWXYZÆ&

abcdefghijklmnopqrstuvwxyz

V. B. MUNSON, SUCCESSOR TO
GEO. BRUCE'S SON & CO., 13 CHAMBERS STREET, NEW YORK.

SEVEN POINT.

MINION.

SEVEN POINT, No. 16.

3-NICK.

THE FIRST FOUNDERS had no common standard of height, thickness or other magnitude, and consequently the shape of the letters cut and cast by them differed very widely. It is easy in an old book to identify the type there used as having been employed in another book, and to state in what printing-office the work was prepared. To some extent the productions of two of the present foundries can still be told apart from all others, as there are differences which serve to mark them. The printers of the cradle age generally cast their own type and made their own punches. The latter were probably of brass or copper, and the matrices of lead. In the Enschedé foundry, in Haarlem, are leaden matrices, said to be derived from punches of copper. They are now over four hundred years old. The metal cast into them only touched them at the end of each type, and was chilled as soon as it touched the leaden plate, leaving this intact. They were also obliged to make their own ink and construct their own presses. Type-founding seems to have been the first of the typographic processes which separated from the others and was carried on as a separate trade. Prior to this a printer was obliged to cut his own punches, fit up his matrices and do his own casting. It is true the number of characters employed with a certain size was small, not much exceeding one hundred; the type was large, thus obviating the necessity of so great an accuracy as was after-

ABCDEFGHIJKLMN O PQRSTU VWXYZÆ&

ABCDEFGHIJKLMN O PQRSTU VWXYZÆ&

§ 1234567890 £ †††††††††† ½ ⅓ ¼ ⅕ ⅖ ¾ ⅞ ⅞

PATENT FIGURES AND FRACTIONS—§ 1234567890 ½ ⅓ ¼ ⅕ ⅖ ¾ ⅞ ⅞

The first founders had no common standard of height, thickness or other magnitude, and consequently the shape of the letters cut and cast by them differed very widely. It is easy

ABCDEFGHIJKLMN O PQRSTU VWXYZÆ&

abcdefghijklmnopqrstuvwxyz

SEVEN POINT, No. 21.

3-NICK.

THE FIRST FOUNDERS had no common standard of height, thickness or other magnitude, and consequently the shape of the letters cut and cast by them differed very widely. It is easy in an old book to identify the type there used as having been employed in another book, and to state in what printing-office the work was prepared. To some extent the productions of two of the present foundries can still be told apart from all others, as there are differences which serve to mark them. The printers of the cradle age generally cast their own type and made their own punches. The latter were probably of brass or copper, and the matrices of lead. In the Enschedé foundry, in Haarlem, are leaden matrices, said to be derived from punches of copper. They are now over four hundred years old. The metal cast into them only touched them at the end of each type, and was chilled as soon as it touched the leaden plate, leaving this intact. They were also obliged to make their own ink and construct their own presses. Type-founding seems to have been the first of the typographic processes which separated from the others and was carried on as a separate trade. Prior to this a printer was obliged to cut his own punches, fit up his matrices and do his own casting. It is true the number of characters employed with a certain size was small, not much exceeding one hundred; the type was large, thus obviating the neces-

ABCDEFGHIJKLMN O PQRSTU VWXYZÆ&

ABCDEFGHIJKLMN O PQRSTU VWXYZÆ&

§ 1234567890 £ †††††††††† ½ ⅓ ¼ ⅕ ⅖ ¾ ⅞ ⅞

PATENT FIGURES AND FRACTIONS—§ 1234567890 ½ ⅓ ¼ ⅕ ⅖ ¾ ⅞ ⅞

The first founders had no common standard of height, thickness or other magnitude, and consequently the shape of the letters cut and cast by them differed very widely. It is easy

ABCDEFGHIJKLMN O PQRSTU VWXYZÆ&

abcdefghijklmnopqrstuvwxyz

V. B. MUNSON, SUCCESSOR TO

GEO. BRUCE'S SON & CO., 13 CHAMBERS STREET, NEW YORK.

EIGHT POINT.

BREVIER.

EIGHT POINT, No. 11.

3-NICK.

THE FIRST FOUNDERS had no common standard of height, thickness or other magnitude, and consequently the shape of the letters cut and cast by them differed very widely. It is easy in an old book to identify the type there used as having been employed in another book, and to state in what printing-office the work was prepared. To some extent the productions of two of the present foundries can still be told apart from all others, as there are differences which serve to mark them. The printers of the cradle age generally cast their own type and made their own punches. The latter were probably of brass or copper, and the matrices of lead. In the Enschedé foundry, in Haarlem, are leaden matrices, said to be derived from punches of copper. They are now over four hundred years old. The metal cast into them only touched them at the end of each type, and was chilled as soon as it touched the leaden plate, leaving this intact. They were also obliged

ABCDEFGHIJKLMN OPQRSTUVWXYZÆ&

ABCDEFGHIJKLMN OPQRSTUVWXYZÆ

\$ 1234567890 £  ½ ⅓ ¼ ⅕ ⅔ ¾ ⅜ ⅝ ⅞

PATENT FIGURES AND FRACTIONS—\$ 1234567890 ½ ⅓ ¼ ⅕ ⅔ ¾ ⅜ ⅝ ⅞

The first founders had no common standard of height, thickness or other magnitude, and consequently the shape of the letters cut and cast by them differed very widely. It is easy in an old book to identify the type there

ABCDEFGHIJKLMN OPQRSTUVWXYZÆ&

abcdefghijklmnopqrstuvwxy

EIGHT POINT, No. 12.

3-NICK.

THE FIRST FOUNDERS had no common standard of height, thickness or other magnitude, and consequently the shape of the letters cut and cast by them differed very widely. It is easy in an old book to identify the type there used as having been employed in another book, and to state in what printing-office the work was prepared. To some extent the productions of two of the present foundries can still be told apart from all others, as there are differences which serve to mark them. The printers of the cradle age generally cast their own type and made their own punches. The latter were probably of brass or copper, and the matrices of lead. In the Enschedé foundry, in Haarlem, are leaden matrices, said to be derived from punches of copper. They are now over four hundred years old. The metal cast into them only touched them at the end of each type, and was chilled

ABCDEFGHIJKLMN OPQRSTUVWXYZÆ&

ABCDEFGHIJKLMN OPQRSTUVWXYZÆ

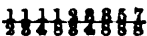
\$ 1234567890 £  ½ ⅓ ¼ ⅕ ⅔ ¾ ⅜ ⅝ ⅞

PATENT FIGURES AND FRACTIONS—\$ 1234567890 ½ ⅓ ¼ ⅕ ⅔ ¾ ⅜ ⅝ ⅞

The first founders had no common standard of height, thickness or other magnitude, and consequently the shape of the letters cut and cast by them differed very widely. It is easy in an old book to identify the

ABCDEFGHIJKLMN OPQRSTUVWXYZÆ&

abcdefghijklmnopqrstuvwxy

V. B. MUNSON, SUCCESSOR TO

GEO. BRUCE'S SON & CO., 13 CHAMBERS STREET, NEW YORK.

EIGHT POINT.

BREVIER.

EIGHT POINT, No. 13.

3-NICK.

THE FIRST FOUNDERS had no common standard of height, thickness or other magnitude, and consequently the shape of the letters cut and cast by them differed very widely. It is easy in an old book to identify the type there used as having been employed in another book, and to state in what printing-office the work was prepared. To some extent the productions of two of the present foundries can still be told apart from all others, as there are differences which serve to mark them. The printers of the cradle age generally cast their own type and made their own punches. The latter were probably of brass or copper, and the matrices of lead. In the Enschedé foundry, in Haarlem, are leaden matrices, said to be derived from punches of copper. They are now over four hundred years old. The metal cast into them only touched them at the end of each type, and was chilled as soon as it touched the leaden plate, leaving this

ABCDEFGHIJKLMN^{OP}QRSTU^VWXYZÆ^{CE}&

ABCDEFGHIJKLMN^{OP}QRSTU^VWXYZÆ^{CE}

\$ 1234567890 £ $\frac{1}{2}$ $\frac{1}{3}$ $\frac{1}{4}$ $\frac{1}{8}$ $\frac{2}{3}$ $\frac{3}{4}$ $\frac{3}{8}$ $\frac{5}{8}$ $\frac{7}{8}$

PATENT FIGURES AND FRACTIONS—\$ 1₂ 1₃ 1₄ 1₈ 2₃ 3₄ 3₈ 5₈ 7₈

The first founders had no common standard of height, thickness or other magnitude, and consequently the shape of the letters cut and cast by them differed very widely. It is easy in an old book to identify the type there used

ABCDEFGHIJKLMN^{OP}QRSTU^VWXYZÆ^{CE}&

abcdefghijklmnopqrstu^vwxyz

EIGHT POINT, No. 14.

3-NICK.

THE FIRST FOUNDERS had no common standard of height, thickness or other magnitude, and consequently the shape of the letters cut and cast by them differed very widely. It is easy in an old book to identify the type there used as having been employed in another book, and to state in what printing-office the work was prepared. To some extent the productions of two of the present foundries can still be told apart from all others, as there are differences which serve to mark them. The printers of the cradle age generally cast their own type and made their own punches. The latter were probably of brass or copper, and the matrices of lead. In the Enschedé foundry, in Haarlem, are leaden matrices, said to be derived from punches of copper. They are now over four hundred years old. The metal cast into them only touched them at the end of each type, and was chilled as soon as it touched the leaden plate, leaving this intact. They were also obliged

ABCDEFGHIJKLMN^{OP}QRSTU^VWXYZÆ^{CE}&

ABCDEFGHIJKLMN^{OP}QRSTU^VWXYZÆ^{CE}

\$ 1234567890 £ $\frac{1}{2}$ $\frac{1}{3}$ $\frac{1}{4}$ $\frac{1}{8}$ $\frac{2}{3}$ $\frac{3}{4}$ $\frac{3}{8}$ $\frac{5}{8}$ $\frac{7}{8}$

PATENT FIGURES AND FRACTIONS—\$ 1₂ 1₃ 1₄ 1₈ 2₃ 3₄ 3₈ 5₈ 7₈

The first founders had no common standard of height, thickness or other magnitude, and consequently the shape of the letters cut and cast by them differed very widely. It is easy in an old book to identify the type there

ABCDEFGHIJKLMN^{OP}QRSTU^VWXYZÆ^{CE}&

abcdefghijklmnopqrstu^vwxyz

V. B. MUNSON, SUCCESSOR TO
GEO. BRUCE'S SON & CO., 13 CHAMBERS STREET, NEW YORK.

EIGHT POINT.

BREVIER.

EIGHT POINT, No. 15.

3-NICK.

THE FIRST FOUNDERS had no common standard of height, thickness or other magnitude, and consequently the shape of the letters cut and cast by them differed very widely. It is easy in an old book to identify the type there used as having been employed in another book, and to state in what printing-office the work was prepared. To some extent the productions of two of the present foundries can still be told apart from all others, as there are differences which serve to mark them. The printers of the cradle age generally cast their own type and made their own punches. The latter were probably of brass or copper, and the matrices of lead. In the Enschedé foundry, in Haarlem, are leaden matrices, said to be derived from punches of copper. They are now over four hundred years old. The metal cast into them only touched them at the end of each type, and was chilled as soon as it touched the leaden plate, leaving this intact. They were also obliged to make their

ABCDEFGHIJKLMN OPQRSTUVWXYZÆ&

ABCDEFGHIJKLMN OPQRSTUVWXYZÆ

\$ 1234567890 £ 1111111111 ½ ⅓ ¼ ⅕ ⅙ ⅗ ⅘ ⅞

PATENT FIGURES AND FRACTIONS—\$ 1234567890 ½ ⅓ ¼ ⅕ ⅙ ⅗ ⅘ ⅞

The first founders had no common standard of height, thickness or other magnitude, and consequently the shape of the letters cut and cast by them differed very widely. It is easy in an old book to identify the type there used as

ABCDEFGHIJKLMN OPQRSTUVWXYZÆ&

abcdefghijklmnopqrstuvwxyz

EIGHT POINT, No. 16.

2-NICK.

THE FIRST FOUNDERS had no common standard of height, thickness or other magnitude, and consequently the shape of the letters cut and cast by them differed very widely. It is easy in an old book to identify the type there used as having been employed in another book, and to state in what printing-office the work was prepared. To some extent the productions of two of the present foundries can still be told apart from all others, as there are differences which serve to mark them. The printers of the cradle age generally cast their own type and made their own punches. The latter were probably of brass or copper, and the matrices of lead. In the Enschedé foundry, in Haarlem, are leaden matrices, said to be derived from punches of copper. They are now over four hundred years old. The metal cast into them only touched them at the end of each type, and was chilled as soon as it touched the leaden plate, leaving this intact. They were also obliged to make their own ink and construct their own presses.

ABCDEFGHIJKLMN OPQRSTUVWXYZÆ&

ABCDEFGHIJKLMN OPQRSTUVWXYZÆ

\$ 1234567890 £ 1111111111 ½ ⅓ ¼ ⅕ ⅙ ⅗ ⅘ ⅞

PATENT FIGURES AND FRACTIONS—\$ 1234567890 ½ ⅓ ¼ ⅕ ⅙ ⅗ ⅘ ⅞

The first founders had no common standard of height, thickness or other magnitude, and consequently the shape of the letters cut and cast by them differed very widely. It is easy in an old book to identify the type there used as having been

ABCDEFGHIJKLMN OPQRSTUVWXYZÆ&

abcdefghijklmnopqrstuvwxyz

V. B. MUNSON, SUCCESSOR TO
GEO. BRUCE'S SON & CO., 13 CHAMBERS STREET, NEW YORK.

EIGHT POINT.

BREVIER.

EIGHT POINT, No. 21.

2-NICK.

THE FIRST FOUNDERS had no common standard of height, thickness or other magnitude, and consequently the shape of the letters cut and cast by them differed very widely. It is easy in an old book to identify the type there used as having been employed in another book, and to state in what printing-office the work was prepared. To some extent the productions of two of the present foundries can still be told apart from all others, as there are differences which serve to mark them. The printers of the cradle age generally cast their own type and made their own punches. The latter were probably of brass or copper, and the matrices of lead. In the Enschedé foundry, in Haarlem, are leaden matrices, said to be derived from punches of copper. They are now over four hundred years old. The metal cast into them only touched them at the end of each type, and was chilled as soon as it touched the leaden plate, leaving this intact. They were also obliged to make their own ink and construct their own presses. Type-founding seems to have been the first of the typographic processes which separated from the others and was carried on as a separate trade. Prior to this a printer was obliged to cut his own punches, fit up his matrices and do his own casting. It is true the number of characters employed with a certain size was small, not much exceeding one hundred; the type

ABCDEFGHIJKLMNOPQRSTUVWXYZÆ&

ABCDEFGHIJKLMNOPQRSTUVWXYZÆ

\$ 1234567890 £ 1111111111 ½ ⅓ ¼ ⅕ ⅔ ¾ ⅞ ⅞

PATENT FIGURES AND FRACTIONS—\$ 1234567890 ½ ⅓ ¼ ⅕ ⅔ ¾ ⅞ ⅞

The first founders had no common standard of height, thickness or other magnitude, and consequently the shape of the letters cut and cast by them differed very widely. It is easy in an old book to identify the type there used as having been employed in another book, and to state in what printing-office the work was prepared. To some extent the productions of two of the present foundries can still be

ABCDEFGHIJKLMNOPQRSTUVWXYZÆ&

abcdefghijklmnopqrstuvwxyz

EIGHT POINT, No. 21.

How can my muse want subject to invent.
While thou dost breathe, that pour'st into my verse
Thine own sweet argument, too excellent
For every vulgar paper to rehearse?
O, give thyself the thanks, if aught in me
Worthy perusal stand against thy sight:
For who's so dumb that cannot write to thee,
When thou thyself dost give invention light?
Be thou the tenth muse, ten times more in worth
Than those old nine rhymers which invoke:
And he that calls on thee, let him bring forth
Eternal numbers to outlive long date.
If my slight muse do please these curious days.
The pain be mine, but thine shall be the praise.

V. B. MUNSON, SUCCESSOR TO
GEO. BRUCE'S SON & CO., 13 CHAMBERS STREET, NEW YORK.

NINE POINT.

BOURGEOIS.

NINE POINT, No. 11.

2-NICK.

THE FIRST FOUNDERS had no common standard of height, thickness or other magnitude, and consequently the shape of the letters cut and cast by them differed very widely. It is easy in an old book to identify the type there used as having been employed in another book, and to state in what printing-office the work was prepared. To some extent the productions of two of the present foundries can still be told apart from all others, as there are differences which serve to mark them. The printers of the cradle age generally cast their own type and made their own punches. The latter were probably of brass or copper, and the matrices of lead. In the Enschedé foundry, in Haarlem, are leaden matrices, said to be derived from punches of copper. They are now over four hundred years old. The metal cast

ABCDEFGHIJKLMN OPQRSTUVWXYZÆŒ&

ABCDEFGHIJKLMN OPQRSTUVWXYZÆŒ

\$ 1234567890 £ ††††††††††

The first founders had no common standard of height, thickness or other magnitude, and consequently the shape of the letters cut and cast by them differed very widely. It is easy in an old book to identify the type

ABCDEFGHIJKLMN OPQRSTUVWXYZÆŒ&

abcdefghijklmnopqrstuvwxy

NINE POINT, No. 13.

2-NICK.

THE FIRST FOUNDERS had no common standard of height, thickness or other magnitude, and consequently the shape of the letters cut and cast by them differed very widely. It is easy in an old book to identify the type there used as having been employed in another book, and to state in what printing-office the work was prepared. To some extent the productions of two of the present foundries can still be told apart from all others, as there are differences which serve to mark them. The printers of the cradle age generally cast their own type and made their own punches. The latter were probably of brass or copper, and the matrices of lead. In the Enschedé foundry, in Haarlem, are leaden matrices, said to be derived from punches of copper. They are now over four hundred years old. The

ABCDEFGHIJKLMN OPQRSTUVWXYZÆŒ&

ABCDEFGHIJKLMN OPQRSTUVWXYZÆŒ

\$ 1234567890 £ ††††††††††

The first founders had no common standard of height, thickness or other magnitude, and consequently the shape of the letters cut and cast by them differed very widely. It is easy in an old book to

ABCDEFGHIJKLMN OPQRSTUVWXYZÆŒ&

abcdefghijklmnopqrstuvwxy

V. B. MUNSON, SUCCESSOR TO
GEO. BRUCE'S SON & CO., 13 CHAMBERS STREET, NEW YORK.

NINE POINT.

BOURGEOIS.

NINE POINT, No. 14.

2-NICK.

THE FIRST FOUNDERS had no common standard of height, thickness or other magnitude, and consequently the shape of the letters cut and cast by them differed very widely. It is easy in an old book to identify the type there used as having been employed in another book, and to state in what printing-office the work was prepared. To some extent the productions of two of the present foundries can still be told apart from all others, as there are differences which serve to mark them. The printers of the cradle age generally cast their own type and made their own punches. The latter were probably of brass or copper, and the matrices of lead. In the Enschedé foundry, in Haarlem, are leaden matrices, said to be derived from punches of copper. They are now over four hundred years old. The

ABCDEFGHIJKLMN OPQRSTUVWXYZÆ&

ABCDEFGHIJKLMN OPQRSTUVWXYZÆ

\$ 1234567890 £ ††††††††††

The first founders had no common standard of height, thickness or other magnitude, and consequently the shape of the letters cut and cast by them differed very widely. It is easy in an old book to

ABCDEFGHIJKLMN OPQRSTUVWXYZÆ&

abcdefghijklmnopqrstuvwxyz

NINE POINT, No. 15.

2-NICK.

THE FIRST FOUNDERS had no common standard of height, thickness or other magnitude, and consequently the shape of the letters cut and cast by them differed very widely. It is easy in an old book to identify the type there used as having been employed in another book, and to state in what printing-office the work was prepared. To some extent the productions of two of the present foundries can still be told apart from all others, as there are differences which serve to mark them. The printers of the cradle age generally cast their own type and made their own punches. The latter were probably of brass or copper, and the matrices of lead. In the Enschedé foundry, in Haarlem, are leaden matrices, said to be derived from punches of copper. They are now over four hundred years old. The metal cast into

ABCDEFGHIJKLMN OPQRSTUVWXYZÆ&

ABCDEFGHIJKLMN OPQRSTUVWXYZÆ

\$ 1234567890 £ ††††††††††

The first founders had no common standard of height, thickness or other magnitude, and consequently the shape of the letters cut and cast by them differed very widely. It is easy in an old book to

ABCDEFGHIJKLMN OPQRSTUVWXYZÆ&

abcdefghijklmnopqrstuvwxyz

V. B. MUNSON, SUCCESSOR TO
GEO. BRUCE'S SON & CO., 13 CHAMBERS STREET, NEW YORK.

NINE POINT.

BOURGEOIS.

NINE POINT, No. 16.

3-NICK.

THE FIRST FOUNDERS had no common standard of height, thickness or other magnitude, and consequently the shape of the letters cut and cast by them differed very widely. It is easy in an old book to identify the type there used as having been employed in another book, and to state in what printing-office the work was prepared. To some extent the productions of two of the present foundries can still be told apart from all others, as there are differences which serve to mark them. The printers of the cradle age generally cast their own type and made their own punches. The latter were probably of brass or copper, and the matrices of lead. In the Enschedé foundry, in Haarlem, are leaden matrices, said to be derived from punches of copper. They are now over four hundred years old. The metal cast into them only touched them at

ABCDEFGHIJKLMN OPQRSTUVWXYZÆŒ&

ABCDEFGHIJKLMN OPQRSTUVWXYZÆŒ

\$ 1234567890 £ ††††††††††

The first founders had no common standard of height, thickness or other magnitude, and consequently the shape of the letters cut and cast by them differed very widely. It is easy in an old book to identify the

ABCDEFGHIJKLMN OPQRSTUVWXYZÆŒ&

abcdefghijklmnopqrstuvwxyz

NINE POINT, No. 21.

2-NICK.

THE FIRST FOUNDERS had no common standard of height, thickness or other magnitude, and consequently the shape of the letters cut and cast by them differed very widely. It is easy in an old book to identify the type there used as having been employed in another book, and to state in what printing-office the work was prepared. To some extent the productions of two of the present foundries can still be told apart from all others, as there are differences which serve to mark them. The printers of the cradle age generally cast their own type and made their own punches. The latter were probably of brass or copper, and the matrices of lead. In the Enschedé foundry, in Haarlem, are leaden matrices, said to be derived from punches

ABCDEFGHIJKLMN OPQRSTUVWXYZÆŒ&

ABCDEFGHIJKLMN OPQRSTUVWXYZÆŒ

\$ 1234567890 £ ††††††††††

The first founders had no common standard of height, thickness or other magnitude, and consequently the shape of the letters cut and cast by them differed very widely. It is easy in an old book to identify the

ABCDEFGHIJKLMN OPQRSTUVWXYZÆŒ&

abcdefghijklmnopqrstuvwxyz

V. B. MUNSON, SUCCESSOR TO
GEO. BRUCE'S SON & CO., 13 CHAMBERS STREET, NEW YORK.

TEN POINT.

LONG PRIMER.

TEN POINT, No. 11.

3-NICK.

THE FIRST FOUNDERS had no common standard of height, thickness or other magnitude, and consequently the shape of the letters cut and cast by them differed very widely. It is easy in an old book to identify the type there used as having been employed in another book, and to state in what printing-office the work was prepared. To some extent the productions of two of the present foundries can still be told apart from all others, as there are differences which serve to mark them. The printers of the cradle age generally cast their own type and made their own punches. The latter were probably of brass or copper, and the matrices of lead. In the Enschedé foundry, in

ABCDEFGHIJKLMN^{OP}QRSTU^VWXYZÆ&

ABCDEFGHIJKLMN^{OP}QRSTU^VWXYZÆ&

\$ 1234567890 £ ~~11112222~~³³³³

The first founders had no common standard of height, thickness or other magnitude, and consequently the letters cut and cast by

ABCDEFGHIJKLMN^{OP}QRSTU^VWXYZÆ&

abcdefghijklmnopqrstu^vwxyz

TEN POINT, No. 13.

3-NICK.

THE FIRST FOUNDERS had no common standard of height, thickness or other magnitude, and consequently the shape of the letters cut and cast by them differed very widely. It is easy in an old book to identify the type there used as having been employed in another book, and to state in what printing-office the work was prepared. To some extent the productions of two of the present foundries can still be told apart from all others, as there are differences which serve to mark them. The printers of the cradle age generally cast their own type and made their own punches. The latter were probably of brass or copper, and the matrices of

ABCDEFGHIJKLMN^{OP}QRSTU^VWXYZÆ&

ABCDEFGHIJKLMN^{OP}QRSTU^VWXYZÆ&

\$ 1234567890 £ ~~11112222~~³³³³

The first founders had no common standard of height, thickness or other magnitude, and consequently the shape of the letters cut

ABCDEFGHIJKLMN^{OP}QRSTU^VWXYZÆ&

abcdefghijklmnopqrstu^vwxyz

V. B. MUNSON, SUCCESSOR TO
GEO. BRUCE'S SON & CO., 13 CHAMBERS STREET, NEW YORK.

TEN POINT.

LONG PRIMER.

TEN POINT, No. 14.

8-NICK.

THE FIRST FOUNDERS had no common standard of height, thickness or other magnitude, and consequently the shape of the letters cut and cast by them differed very widely. It is easy in an old book to identify the type there used as having been employed in another book, and to state in what printing-office the work was prepared. To some extent the productions of two of the present foundries can still be told apart from all others, as there are differences which serve to mark them. The printers of the cradle age generally cast their own type and made their own punches. The latter were probably of brass or copper, and the matrices of lead. In the Enschedé foundry, in

ABCDEFGHIJKLMN~~OP~~QRSTU~~VW~~XYZÆ&

ABCDEFGHIJKLMN~~OP~~QRSTU~~VW~~XYZÆ&

\$ 1234567890 £ ~~11112222~~
~~33334444~~

The first founders had no common standard of height, thickness or other magnitude, and consequently the shape of the

ABCDEFGHIJKLMN~~OP~~QRSTU~~VW~~XYZÆ&

abcdefghijklmnopqrstuvwxy~~z~~

TEN POINT, No. 15.

8-NICK.

THE FIRST FOUNDERS had no common standard of height, thickness or other magnitude, and consequently the shape of the letters cut and cast by them differed very widely. It is easy in an old book to identify the type there used as having been employed in another book, and to state in what printing-office the work was prepared. To some extent the productions of two of the present foundries can still be told apart from all others, as there are differences which serve to mark them. The printers of the cradle age generally cast their own type and made their own punches. The latter were probably of brass or copper, and the matrices of lead. In the Enschedé foundry, in Haarlem, are leaden

ABCDEFGHIJKLMN~~OP~~QRSTU~~VW~~XYZÆ&

ABCDEFGHIJKLMN~~OP~~QRSTU~~VW~~XYZÆ&

\$ 1234567890 £ ~~11112222~~
~~33334444~~

The first founders had no common standard of height, thickness or other magnitude, and consequently the shape of the

ABCDEFGHIJKLMN~~OP~~QRSTU~~VW~~XYZÆ&

abcdefghijklmnopqrstuvwxy~~z~~

V. B. MUNSON, SUCCESSOR TO
GEO. BRUCE'S SON & CO., 13 CHAMBERS STREET, NEW YORK.

TEN POINT.

LONG PRIMER.

TEN POINT, No. 16.

2-NICK.

THE FIRST FOUNDERS had no common standard of height, thickness or magnitude, and consequently the shape of the letters cut and cast by them differed very widely. It is easy in an old book to identify the type there used as having been employed in another book, and to state in what printing-office the work was prepared. To some extent the productions of two of the present foundries can still be told apart from all others, as there are differences which serve to mark them. The printers of the cradle age generally cast their own type and made their own punches. The latter were probably of brass or copper, and the matrices of lead. In the Enschedé foundry, in Haarlem, are leaden matrices, said to be derived from

ABCDEFGHIJKLMN~~OP~~QRSTU~~VW~~XYZÆ~~Œ~~&

ABCDEFGHIJKLMN~~OP~~QRSTU~~VW~~XYZÆ~~Œ~~

§ 1234567890 £ ~~1111233357~~
~~2348834888~~

The first founders had no common standard of height, thickness or other magnitude, and consequently the shape of the letters cut and

ABCDEFGHIJKLMN~~OP~~QRSTU~~VW~~XYZÆ~~Œ~~&

abcdefghijklmnopqrstuvwxy~~z~~

TEN POINT, No. 19.

3-NICK.

THE FIRST FOUNDERS had no common standard of height, thickness or other magnitude, and consequently the shape of the letters cut and cast by them differed very widely. It is easy in an old book to identify the type there used as having been employed in another book, and to state in what printing-office the work was prepared. To some extent the productions of two of the present foundries can still be told apart from all others, as there are differences which serve to mark them. The printers of the cradle age generally cast their own type and made their own punches. The latter were probably of brass or copper, and the matrices of lead. In the Enschedé foundry, in Haarlem, are leaden

ABCDEFGHIJKLMN~~OP~~QRSTU~~VW~~XYZÆ~~Œ~~&

ABCDEFGHIJKLMN~~OP~~QRSTU~~VW~~XYZÆ~~Œ~~

§ 1234567890 £ ~~1111233357~~
~~2348834888~~

The first founders had no common standard of height, thickness or other magnitude, and consequently the shape of the letters cut and

ABCDEFGHIJKLMN~~OP~~QRSTU~~VW~~XYZÆ~~Œ~~&

abcdefghijklmnopqrstuvwxy~~z~~

V. B. MUNSON, SUCCESSOR TO
GEO. BRUCE'S SON & CO., 13 CHAMBERS STREET, NEW YORK.

TEN POINT.

LONG PRIMER.

TEN POINT, No. 21.

3-NICK.

THE FIRST FOUNDERS had no common standard of height, thickness or other magnitude, and consequently the shape of the letters cut and cast by them differed very widely. It is easy in an old book to identify the type there used as having been employed in another book, and to state in what printing-office the work was prepared. To some extent the productions of two of the present foundries can still be told apart from all others, as there are differences which serve to mark them. The printers of the cradle age generally cast their own type and made their own punches. The latter were probably of brass or copper, and the matrices of lead. In the Enschedé foundry, in Haarlem, are leaden matrices, said to be derived from punches of copper. They are now over four hundred years old. The metal cast into them only touched them at the end of each type, and was chilled as soon as it touched the leaden plate, leaving this intact. They were also obliged to make their own ink and construct their own presses. Type-founding seems to have been the first of the typographic processes which separated from the others and was carried on as a separate trade. Prior to this a printer was obliged to cut his own punches, fit up his matrices and do his casting. It is true the number of characters employed with a certain size was small, not much exceeding one hundred; the type was large, thus obviating the necessity of so great an accuracy as was afterwards requisite, and few faces were necessary. Many printing-offices of the sixteenth century had only four or five sizes of type. The quantity required was also small. Enough for two quarto pages would do, if there were no more, and three or four cases full of type were amply sufficient. A printer could sometimes buy the stock of another who was declining business; he might induce a friend in another town to cast letter for him, and he could take some comparatively new characters from an old font,

ABCDEFGHIJKLMN OPQRSTUVWXYZÆŒ&

ABCDEFGHIJKLMN OPQRSTUVWXYZÆŒ

§ 1234567890 £ 1111222257
2348884888

The first founders had no common standard of height, thickness or other magnitude, and consequently the shape of the letters cut and cast by them differed very widely. It is easy in an old book to identify the type there used as having been employed in another book

ABCDEFGHIJKLMN OPQRSTUVWXYZÆŒ&

abcdefghijklmnopqrstuvwxy z

V. B. MUNSON, SUCCESSOR TO
GEO. BRUCE'S SON & CO., 13 CHAMBERS STREET, NEW YORK.

ELEVEN POINT.

SMALL PICA.

ELEVEN POINT, No. 11.

2-NICK.

THE FIRST FOUNDERS had no common standard of height, thickness or other magnitude, and consequently the shape of the letters cut and cast by them differed very widely. It is easy in an old book to identify the type there used as having been employed in another book, and to state in what printing-office the work was prepared. To some extent the productions of two of the present foundries can still be told apart from all others, as there are differences which serve to mark them. The printers of the cradle age generally cast their own

ABCDEFGHIJKLMNOPQRSTUVWXYZÆŒ&

ABCDEFGHIJKLMNOPQRSTUVWXYZÆŒ

\$ 1234567890 £ ½¼¼¾¾¾¾¾

The first founders had no common standard of height, thickness or other magnitude, and consequently the shape of the letters cut

ABCDEFGHIJKLMNOPQRSTUVWXYZÆŒ&

abcdefghijklmnopqrstuvwxy

ELEVEN POINT, No. 13.

2-NICK.

THE FIRST FOUNDERS had no common standard of height, thickness or other magnitude, and consequently the shape of the letters cut and cast by them differed very widely. It is easy in an old book to identify the type there used as having been employed in another book, and to state in what printing-office the work was prepared. To some extent the productions of two of the present foundries can still be told apart from all others, as there are differences which serve to mark them. The printers of the cradle age generally cast their own

ABCDEFGHIJKLMNOPQRSTUVWXYZÆŒ&

ABCDEFGHIJKLMNOPQRSTUVWXYZÆŒ

\$ 1234567890 £ ½¼¼¾¾¾¾¾

The first founders had no common standard of height, thickness or other magnitude, and consequently the shape of the letters cut

ABCDEFGHIJKLMNOPQRSTUVWXYZÆŒ&

abcdefghijklmnopqrstuvwxy

V. B. MUNSON, SUCCESSOR TO
GEO. BRUCE'S SON & CO., 13 CHAMBERS STREET, NEW YORK.

ELEVEN POINT.

SMALL PICA.

ELEVEN POINT, No. 15.

2-NICK.

THE FIRST FOUNDERS had no common standard of height, thickness or other magnitude, and consequently the shape of the letters cut and cast by them differed very widely. It is easy in an old book to identify the type there used as having been employed in another book, and to state in what printing-office the work was prepared. To some extent the productions of two of the present foundries can still be told apart from all others, as there are differences which serve to mark them. The printers of the cradle age generally cast their own type and made their own

ABCDEFGHIJKLMN OPQRSTUVWXYZÆŒ&

ABCDEFGHIJKLMN OPQRSTUVWXYZÆŒ

§ 1234567890 £ 1111222233334444

The first founders had no common standard of height, thickness or other magnitude, and consequently the shape of the letters cut

ABCDEFGHIJKLMN OPQRSTUVWXYZÆŒ&

abcdefghijklmnopqrstuvwxyz

ELEVEN POINT, No. 16.

2-NICK.

THE FIRST FOUNDERS had no common standard of height, thickness or other magnitude, and consequently the shape of the letters cut and cast by them differed very widely. It is easy in an old book to identify the type there used as having been employed in another book, and to state in what printing-office the work was prepared. To some extent the productions of two of the present foundries can still be told apart from all others, as there are differences which serve to mark them. The printers of the cradle age generally cast their own type and made their own punches. The

ABCDEFGHIJKLMN OPQRSTUVWXYZÆŒ&

ABCDEFGHIJKLMN OPQRSTUVWXYZÆŒ

§ 1234567890 £ 1111222233334444

The first founders had no common standard of height, thickness or other magnitude, and consequently the shape of the letters cut and cast by them

ABCDEFGHIJKLMN OPQRSTUVWXYZÆŒ&

abcdefghijklmnopqrstuvwxyz

V. B. MUNSON, SUCCESSOR TO
GEO. BRUCE'S SON & CO., 13 CHAMBERS STREET, NEW YORK.

ELEVEN POINT.

SMALL PICA.

ELEVEN POINT, No. 17.

2-NICK.

THE FIRST FOUNDERS had no common standard of height, thickness or other magnitude, and consequently the shape of the letters cut and cast by them differed very widely. It is easy in an old book to identify the type there used as having been employed in another book, and to state in what printing-office the work was prepared. To some extent the productions of two of the present foundries can still be told apart from all others, as there are differences which serve to mark them. The printers of the cradle age generally cast their own type and made their own punches. The latter were probably of brass

ABCDEFGHIJKLMN OPQRSTUVWXYZÆ&

ABCDEFGHIJKLMN OPQRSTUVWXYZÆ&

\$ 1234567890 £ 1111222257
1111222257

The first founders had no common standard of height, thickness or other magnitude, and consequently the shape of the letters cut and cast by them

ABCDEFGHIJKLMN OPQRSTUVWXYZÆ&

abcdefghijklmnopqrstuvwxy

ELEVEN POINT, No. 18.

2-NICK.

THE FIRST FOUNDERS had no common standard of height, thickness or other magnitude, and consequently the shape of the letters cut and cast by them differed very widely. It is easy in an old book to identify the type there used as having been employed in another book, and to state in what printing-office the work was prepared. To some extent the productions of two of the present foundries can still be told apart from all others, as there are differences which serve to mark them. The printers of the cradle age generally cast their own type and made their own punches. The

ABCDEFGHIJKLMN OPQRSTUVWXYZÆ&

ABCDEFGHIJKLMN OPQRSTUVWXYZÆ&

\$ 1234567890 £ 1111222257
1111222257

The first founders had no common standard of height, thickness or other magnitude, and consequently the shape of the letters cut and cast by them

ABCDEFGHIJKLMN OPQRSTUVWXYZÆ&

abcdefghijklmnopqrstuvwxy

V. B. MUNSON, SUCCESSOR TO
GEO. BRUCE'S SON & CO., 13 CHAMBERS STREET, NEW YORK.

ELEVEN POINT.

SMALL PICA.

ELEVEN POINT, No. 21.

2-NICK.

THE FIRST FOUNDERS had no common standard of height, thickness or other magnitude, and consequently the shape of the letters cut and cast by them differed very widely. It is easy in an old book to identify the type there used as having been used in another book, and to state in what printing-office the work was prepared. To some extent the productions of two of the present foundries can still be told apart from all others, as there are differences which serve to mark them. The printers of the cradle age generally cast their own type and made their own punches. The latter were probably of brass or copper, and the matrices of lead. In the Enschedé foundry, in Haarlem, are leaden matrices, said to be derived from punches of copper. They are now over four hundred years old. The metal cast into them only touched them at the end of each type, and was chilled as soon as it touched the leaden plate, leaving this intact. They were also obliged to make their own ink and construct their own presses. Type-founding seems to have been the first of the typographic processes which separated from the others and was carried on as a separate trade. Prior to this a printer was obliged to cut his own punches, fit up his matrices and do his own casting. It is true the number of characters employed with a certain size was small, not much exceeding one hundred; the type was large, thus obviating the necessity of so great an accuracy as was afterwards requisite, and few faces were necessary. Many printing-offices of the sixteenth century had only four or five sizes of type. The quantity required was also small. Enough for two quarto pages would do, if there

ABCDEFGHIJKLMN OPQRSTUVWXYZÆŒ&

ABCDEFGHIJKLMN OPQRSTUVWXYZÆŒ

\$ 1234567890 £ 1 1 1 1 2 2 2 2 3 3 3 3 4 4 4 4 5 5 5 5 6 6 6 6 7 7 7 7

The first founders had no common standard of height, thickness or other magnitude, and consequently the shape of the letters cut and cast by them differed very widely. It is easy in an old book to identify the type there used as having been employed in another book, and to state in what print-

ABCDEFGHIJKLMN OPQRSTUVWXYZÆŒ&

abcdefghijklmnopqrstuvwxy z

V. B. MUNSON, SUCCESSOR TO
GEO. BRUCE'S SON & CO., 13 CHAMBERS STREET, NEW YORK.

TWELVE POINT.

PICA.

TWELVE POINT, No. 11.

3-NICK.

THE FIRST FOUNDERS had no common standard of height, thickness or other magnitude, and consequently the shape of the letters cut and cast by them differed very widely. It is easy in an old book to identify the type there used as having been employed in another book, and to state in what printing-office the work was prepared. To some extent the productions of two of the present foundries can still be told

ABCDEFGHIJKLMN**OP**QRSTU**VW**XYZÆŒ&

ABCDEFGHIJKLMN**OP**QRSTU**VW**XYZÆŒ

\$ 1234567890 £ ~~111123357~~
~~234834888~~

The first founders had no common standard of height, thickness or other magnitude, and consequently the shape of the

*ABCDEFGHIJKLMN**OP**QRSTU**VW**XYZÆŒ&*

abcdefghijklmnopqrstuvwxy
z

TWELVE POINT, No. 13.

3-NICK.

THE FIRST FOUNDERS had no common standard of height, thickness or other magnitude, and consequently the shape of the letters cut and cast by them differed very widely. It is easy in an old book to identify the type there used as having been employed in another book, and to state in what printing-office the work was prepared. To some extent the productions of two of the present foundries can still be told

ABCDEFGHIJKLMN**OP**QRSTU**VW**XYZÆŒ&

ABCDEFGHIJKLMN**OP**QRSTU**VW**XYZÆŒ

\$ 1234567890 £ ~~111123357~~
~~234834888~~

The first founders had no common standard of height, thickness or other magnitude, and consequently the shape of the

*ABCDEFGHIJKLMN**OP**QRSTU**VW**XYZÆŒ&*

abcdefghijklmnopqrstuvwxy
z

V. B. MUNSON, SUCCESSOR TO
GEO. BRUCE'S SON & CO., 13 CHAMBERS STREET, NEW YORK.

TWELVE POINT.

PICA.

TWELVE POINT, No. 16.

2-NICK.

THE FIRST FOUNDERS had no common standard of height, thickness or other magnitude, and consequently the shape of the letters cut and cast by them differed very widely. It is easy in an old book to identify the type there used as having been employed in another book, and to state in what printing-office the work was prepared. To some extent the productions of two of the present foundries can still be told apart from all others, as there are differ-

ABCDEFGHIJKLMN~~OP~~QRSTU~~VW~~XYZÆ~~Œ~~&

ABCDEFGHIJKLMN~~OP~~QRSTU~~VW~~XYZÆ~~Œ~~

\$ 1234567890 £ ~~111123357~~
~~234834888~~

The first founders had no common standard of height, thickness or other magnitude, and consequently the shape of the letters cut

ABCDEFGHIJKLMN~~OP~~QRSTU~~VW~~XYZÆ~~Œ~~&

abcdefghijklmnopqrstu~~vw~~xyz

TWELVE POINT, No. 18.

3-NICK.

THE FIRST FOUNDERS had no common standard of height, thickness or other magnitude, and consequently the shape of the letters cut and cast by them differed very widely. It is easy in an old book to identify the type there used as having been employed in another book, and to state in what printing-office the work was prepared. To some extent the productions of two of the present foundries can still be told apart from all others, as there are differences which serve

ABCDEFGHIJKLMN~~OP~~QRSTU~~VW~~XYZÆ~~Œ~~&

ABCDEFGHIJKLMN~~OP~~QRSTU~~VW~~XYZÆ~~Œ~~

\$ 1234567890 £ ~~111123357~~
~~234834888~~

The first founders had no common standard of height, thickness or other magnitude, and consequently the shape of the letters

ABCDEFGHIJKLMN~~OP~~QRSTU~~VW~~XYZÆ~~Œ~~&

abcdefghijklmnopqrstu~~vw~~xyz

TWELVE POINT.

PICA.

TWELVE POINT, No. 21.

3-NICK.

THE FIRST FOUNDERS had no common standard of height, thickness or other magnitude, and consequently the shape of the letters cut and cast by them differed very widely. It is easy in an old book to identify the type there used as having been employed in another book, and to state in what printing-office the work was prepared. To some extent the productions of two of the present foundries can still be told apart from all others, as there are differences which serve to mark them. The printers of the cradle age generally cast their own type and made their own punches. The latter were probably of brass or copper, and the matrices of lead. In the Enschedé foundry, in Haarlem, are leaden matrices, said to be derived from punches of copper. They are now over four hundred years old. The metal cast into them only touched them at the end of each type, and was chilled as soon as it touched the leaden plate, leaving this intact. They were also obliged to make their own ink and construct their own presses. Type-founding seems to have been the first of the typographic processes which separated from the others and was carried on as a separate trade. Prior to this a printer was obliged to cut his own punches, fit up his matrices and do his own casting. It is true the number

ABCDEFGHIJKLMNOPQRSTUVWXYZÆŒ&

ABCDEFGHIJKLMNOPQRSTUVWXYZÆŒ

\$ 1234567890 £ 111123357
234834888

The founders had no common standard of height, thickness or magnitude, and consequently the shape of the letters cut by them differed very widely. It is easy in an old book to identify the type there used as having been employed

ABCDEFGHIJKLMNOPQRSTUVWXYZÆŒ&

abcdefghijklmnopqrstuvwxy

MUNSON, SUCCESSOR TO

GEO. BUNSON & CO., 13 CHAMBERS STREET, NEW YORK.

FOURTEEN POINT.

ENGLISH.

FOURTEEN POINT, No. 13.

2-NICK.

THE FIRST FOUNDERS had no common standard of height, thickness or other magnitude, and consequently the shape of the letters cut and cast by them differed very widely. It is easy in an old book to identify the type there used as having been employed in another book, and to state in what printing-office the work was prepared. To some extent the productions of two of the present foundries can still be told apart from all others, as there are differences which serve to mark them. The printers of the cradle age generally cast their own type and made their own punches. The latter were probably of brass or copper, and the matrices of lead. In the Enschedé foundry, in Haarlem, are leaden matrices, said to have been derived from punches of copper. They are now over four hundred years old. The metal cast into them touched them only at the end of each type, and was chilled as soon as it touched the leaden plate, leaving this intact. They were also obliged to make their own ink and construct their own presses. Type-found-

ABCDEFGHIJKLMN**OP**QRSTU**V**WXYZÆŒ

ABCDEFGHIJKLMN**OP**QRSTU**V**WXYZÆŒ

\$ 1234567890 £ $\frac{111123357}{234834888}$

The first founders had no common standard of height, thickness or other magnitude, and conse-

*ABCDEFGHIJKLMN**OP**QRSTU**V**W*

*abcdefghijklmnopqrstuvwxy**z***

V. B. MUNSON, SUCCESSOR TO
GEO. BRUCE'S SON & CO., 13 CHAMBERS STREET, NEW YORK.

FOURTEEN POINT.

ENGLISH.

FOURTEEN POINT, No. 16.

1-NICK.

THE FIRST FOUNDERS had no common standard of height, thickness or other magnitude, and consequently the shape of the letters cut and cast by them differed very widely. It is easy in an old book to identify the type there used as having been employed in another book, and to state in what printing-office the work was prepared. To some extent the productions of two of the present foundries can still be told apart from all others, as there are differences which serve to mark them. The printers of the cradle age generally cast their own type and made their own punches. The latter were probably of brass or copper, and the matrices of lead. In the Enschedé foundry, in Haarlem, are leaden matrices, said to be derived from punches of copper. They are now over four hundred years old. The metal cast into them only touched them at the end of each type, and was chilled as soon as it touched the leaden plate, leaving this intact. They were also obliged to make their own ink and construct their own presses. Type-founding seems to have been the first of the typographic

ABCDEFGHIJKLMNOPQRSTUVWXYZÆŒ&

ABCDEFGHIJKLMNOPQRSTUVWXYZÆŒ

\$ 1234567890 £ $\frac{111123357}{234834888}$

The first founders had no common standard of height, thickness or other magnitude, and consequently the shape

ABCDEFGHIJKLMNOPQRSTUVWXYZ

abcdefghijklmnopqrstvwxyz

V. B. MUNSON, SUCCESSOR TO
GEO. BRUCE'S SON & CO., 13 CHAMBERS STREET, NEW YORK.

FOURTEEN POINT.

ENGLISH.

FOURTEEN POINT, No. 19.

1-NICK.

THE FIRST FOUNDERS had no common standard of height, thickness or other magnitude, and consequently the shape of the letters cut and cast by them differed very widely. It is easy in an old book to identify the type there used as having been employed in another book, and to state in what printing-office the work was prepared. To some extent the productions of two of the present foundries can still be told apart from all others, as there are differences which serve to mark them. The printers of the cradle age generally cast their own type and made their own punches. The latter were probably of brass or copper, and the matrices of lead. In the En-schedé foundry, in Haarlem, are leaden matrices, said to be derived from punches of copper. They are now over four hundred years old. The metal cast into them only touched them at the end of each type, and was chilled as soon as it touched the leaden plate, leaving this intact. They were also obliged to make their own ink and construct their own presses. Type-founding seems to have been the first of the typographic processes which separated from the others and was carried on as a separate

ABCDEFGHIJKLMNOPQRSTUVWXYZÆŒ&

ABCDEFGHIJKLMNOPQRSTUVWXYZÆŒ

\$ 1234567890 £ ~~111123357~~
~~234884888~~

The first founders had no common standard of height, thickness or other magnitude, and consequently the shape

ABCDEFGHIJKLMNOPQRSTUVWXYZ

abcdefghijklmnopqrstuvwxy

V. B. MUNSON, SUCCESSOR TO
GEO. BRUCE'S SON & CO., 13 CHAMBERS STREET, NEW YORK.

SIXTEEN POINT.

COLUMBIAN.

SIXTEEN POINT, No. 18.

1-NICK.

THE FIRST FOUNDERS had not a common standard of height, thickness or other magnitude, and consequently the shape of the letters cut and cast by them differed very widely. It is an easy matter in an old book to identify the type there used as having been employed in another book, and to state in what printing-office the work was prepared. To some extent the productions of two of the present foundries can still be told apart from all others, as there are differences which serve to mark them. The printers of the cradle age generally cast their own type and made their own punches. The latter were probably of brass or copper, and the matrices of lead. In the Enschedé foundry, in Haarlem, are leaden matrices, said to be derived from punches of copper. They are

ABCDEFGHIJKLMN OPQRSTU

ABCDEFGHIJKLMN OPQRSTUVWXYZÆŒ

\$ 1234567890 £ $\frac{111123357}{234834888}$

The first founders had not a common standard of height, thickness or other magnitude, and consequently the shape of the letters cut and

ABCDEFGHIJKLMN OPQRS

abcdefghijklmnopqrstuvwxyz

V. B. MUNSON, SUCCESSOR TO
GEO. BRUCE'S SON & CO., 13 CHAMBERS STREET, NEW YORK.

TWELVE POINT.

PICA.

TWELVE POINT, No. 16.

2-NICK.

THE FIRST FOUNDERS had no common standard of height, thickness or other magnitude, and consequently the shape of the letters cut and cast by them differed very widely. It is easy in an old book to identify the type there used as having been employed in another book, and to state in what printing-office the work was prepared. To some extent the productions of two of the present foundries can still be told apart from all others, as there are differ-

ABCDEFGHIJKLMN~~OP~~QRSTU~~V~~WXYZÆ~~Œ~~&

ABCDEFGHIJKLMN~~OP~~QRSTU~~V~~WXYZÆ~~Œ~~

\$ 1234567890 £ ~~111123357~~
~~234834888~~

The first founders had no common standard of height, thickness or other magnitude, and consequently the shape of the letters cut

ABCDEFGHIJKLMN~~OP~~QRSTU~~V~~WXYZÆ~~Œ~~&

abcdefghijklmnopqrstuvwxy~~z~~

TWELVE POINT, No. 18.

3-NICK.

THE FIRST FOUNDERS had no common standard of height, thickness or other magnitude, and consequently the shape of the letters cut and cast by them differed very widely. It is easy in an old book to identify the type there used as having been employed in another book, and to state in what printing-office the work was prepared. To some extent the productions of two of the present foundries can still be told apart from all others, as there are differences which serve

ABCDEFGHIJKLMN~~OP~~QRSTU~~V~~WXYZÆ~~Œ~~&

ABCDEFGHIJKLMN~~OP~~QRSTU~~V~~WXYZÆ~~Œ~~

\$ 1234567890 £ ~~111123357~~
~~234834888~~

The first founders had no common standard of height, thickness or other magnitude, and consequently the shape of the letters cut

ABCDEFGHIJKLMN~~OP~~QRSTU~~V~~WXYZÆ~~Œ~~&

abcdefghijklmnopqrstuvwxy~~z~~

V. B. MUNSON, SUCCESSOR TO
GEO. BRUCE'S SON & CO., 13 CHAMBERS STREET, NEW YORK.

TWELVE POINT.

PICA.

TWELVE POINT, No. 21.

3-NICK.

THE FIRST FOUNDERS had no common standard of height, thickness or other magnitude, and consequently the shape of the letters cut and cast by them differed very widely. It is easy in an old book to identify the type there used as having been employed in another book, and to state in what printing-office the work was prepared. To some extent the productions of two of the present foundries can still be told apart from all others, as there are differences which serve to mark them. The printers of the cradle age generally cast their own type and made their own punches. The latter were probably of brass or copper, and the matrices of lead. In the Enschedé foundry, in Haarlem, are leaden matrices, said to be derived from punches of copper. They are now over four hundred years old. The metal cast into them only touched them at the end of each type, and was chilled as soon as it touched the leaden plate, leaving this intact. They were also obliged to make their own ink and construct their own presses. Type-founding seems to have been the first of the typographic processes which separated from the others and was carried on as a separate trade. Prior to this a printer was obliged to cut his own punches, fit up his matrices and do his own casting. It is true the number

ABCDEFGHIJKLMN OPQRSTUVWXYZÆŒ&

ABCDEFGHIJKLMN OPQRSTUVWXYZÆŒ

\$ 1234567890 £ ~~111123357~~
~~234834888~~

The first founders had no common standard of height, thickness or other magnitude, and consequently the shape of the letters cut and cast by them differed very widely. It is easy in an old book to identify the type there used as having been employed

ABCDEFGHIJKLMN OPQRSTUVWXYZÆŒ&

abcdefghijklmnopqrstuvwxy z

V. B. MUNSON, SUCCESSOR TO
GEO. BRUCE'S SON & CO., 13 CHAMBERS STREET, NEW YORK.

FOURTEEN POINT.

ENGLISH.

FOURTEEN POINT, No. 18.

2-NICK.

THE FIRST FOUNDERS had no common standard of height, thickness or other magnitude, and consequently the shape of the letters cut and cast by them differed very widely. It is easy in an old book to identify the type there used as having been employed in another book, and to state in what printing-office the work was prepared. To some extent the productions of two of the present foundries can still be told apart from all others, as there are differences which serve to mark them. The printers of the cradle age generally cast their own type and made their own punches. The latter were probably of brass or copper, and the matrices of lead. In the Enschedé foundry, in Haarlem, are leaden matrices, said to have been derived from punches of copper. They are now over four hundred years old. The metal cast into them touched them only at the end of each type, and was chilled as soon as it touched the leaden plate, leaving this intact. They were also obliged to make their own ink and construct their own presses. Type-found-

ABCDEFGHIJKLMN OPQRSTUVWXYZÆŒ

ABCDEFGHIJKLMN OPQRSTUVWXYZÆŒ

\$ 1234567890 £ $\frac{111123357}{234834888}$

The first founders had no common standard of height, thickness or other magnitude, and conse-

ABCDEFGHIJKLMN OPQRSTUVWXYZ

abcdefghijklmnopqrstuvwxyz

V. B. MUNSON, SUCCESSOR TO
GEO. BRUCE'S SON & CO., 13 CHAMBERS STREET, NEW YORK.

FOURTEEN POINT.

ENGLISH.

FOURTEEN POINT, No. 16.

1-NICK.

THE FIRST FOUNDERS had no common standard of height, thickness or other magnitude, and consequently the shape of the letters cut and cast by them differed very widely. It is easy in an old book to identify the type there used as having been employed in another book, and to state in what printing-office the work was prepared. To some extent the productions of two of the present foundries can still be told apart from all others, as there are differences which serve to mark them. The printers of the cradle age generally cast their own type and made their own punches. The latter were probably of brass or copper, and the matrices of lead. In the Enschedé foundry, in Haarlem, are leaden matrices, said to be derived from punches of copper. They are now over four hundred years old. The metal cast into them only touched them at the end of each type, and was chilled as soon as it touched the leaden plate, leaving this intact. They were also obliged to make their own ink and construct their own presses. Type-founding seems to have been the first of the typographic

ABCDEFGHIJKLMN OPQRSTUVWXYZÆŒ&

ABCDEFGHIJKLMN OPQRSTUVWXYZÆŒ

\$ 1234567890 £ ~~111123357~~
~~234834888~~

The first founders had no common standard of height, thickness or other magnitude, and consequently the shape

ABCDEFGHIJKLMN OPQRSTUVWXYZ

abcdefghijklmnopqrstuvwxy

V. B. MUNSON, SUCCESSOR TO
GEO. BRUCE'S SON & CO., 13 CHAMBERS STREET, NEW YORK.

FOURTEEN POINT.

ENGLISH.

FOURTEEN POINT, No. 19.

1-NICK.

THE FIRST FOUNDERS had no common standard of height, thickness or other magnitude, and consequently the shape of the letters cut and cast by them differed very widely. It is easy in an old book to identify the type there used as having been employed in another book, and to state in what printing-office the work was prepared. To some extent the productions of two of the present foundries can still be told apart from all others, as there are differences which serve to mark them. The printers of the cradle age generally cast their own type and made their own punches. The latter were probably of brass or copper, and the matrices of lead. In the Enschedé foundry, in Haarlem, are leaden matrices, said to be derived from punches of copper. They are now over four hundred years old. The metal cast into them only touched them at the end of each type, and was chilled as soon as it touched the leaden plate, leaving this intact. They were also obliged to make their own ink and construct their own presses. Type-founding seems to have been the first of the typographic processes which separated from the others and was carried on as a separate

ABCDEFGHIJKLMNOPQRSTUVWXYZÆŒ&

ABCDEFGHIJKLMNOPQRSTUVWXYZÆŒ

\$ 1234567890 £ $\frac{111123357}{234884888}$

The first founders had no common standard of height, thickness or other magnitude, and consequently the shape

ABCDEFGHIJKLMNOPQRSTUVWXYZ

abcdefghijklmnopqrstuvwxyz

V. B. MUNSON, SUCCESSOR TO
GEO. BRUCE'S SON & CO., 13 CHAMBERS STREET, NEW YORK.

SIXTEEN POINT.

COLUMBIAN.

SIXTEEN POINT, No. 18.

1-NICK.

THE FIRST FOUNDERS had not a common standard of height, thickness or other magnitude, and consequently the shape of the letters cut and cast by them differed very widely. It is an easy matter in an old book to identify the type there used as having been employed in another book, and to state in what printing-office the work was prepared. To some extent the productions of two of the present foundries can still be told apart from all others, as there are differences which serve to mark them. The printers of the cradle age generally cast their own type and made their own punches. The latter were probably of brass or copper, and the matrices of lead. In the Enschedé foundry, in Haarlem, are leaden matrices, said to be derived from punches of copper. They are

ABCDEFGHIJKLMNQRSTU

ABCDEFGHIJKLMNQRSTUVWXYZÆŒ

\$ 1234567890 £ $\frac{111123357}{234834888}$

The first founders had not a common standard of height, thickness or other magnitude, and consequently the shape of the letters cut and

ABCDEFGHIJKLMNQRST

abcdefghijklmnopqrstuvwxyz

V. B. MUNSON, SUCCESSOR TO
GEO. BRUCE'S SON & CO., 13 CHAMBERS STREET, NEW YORK.

EIGHTEEN POINT.

GREAT PRIMER.

EIGHTEEN POINT, No. 13.

1-NICK.

THE FIRST FOUNDERS had not a common standard of height, thickness or other magnitude, and consequently the shape of the letters cut and cast by them differed very widely. It is easy in an old book to identify the type there used as having been employed in another book, and to state in what printing-office the work was prepared. To some extent the productions of two of the present foundries can still be told apart from all others, as there are differences which serve to mark them. The printers of the cradle age generally cast their own type and made their own punches. The latter were probably of

ABCDEFGHIJKLMN**OP**QRSTUVWX

ABCDEFGHIJKLMN**OP**QRSTUVWXYZÆŒ

\$ 1234567890 £ $\frac{111123357}{234834888}$

The first founders had no common standard of height, thickness or other magnitude, and consequently the shape of the letters cut

*ABCDEFGHIJKLMN**OP**QRST*

abcdefghijklmnopqrstvwxyz

V. B. MUNSON, SUCCESSOR TO
GEO. BRUCE'S SON & CO., 13 CHAMBERS STREET, NEW YORK.

EIGHTEEN POINT.

GREAT PRIMER.

EIGHTEEN POINT, No. 16.

1-NICK.

THE FIRST FOUNDERS had no common standard of height, thickness or other magnitude, and consequently the shape of the letters cut and cast by them differed very widely. It is easy in an old book to identify the type there used as having been used in another book, and to state in what printing-office the work was prepared. To some extent the productions of two of the present foundries can still be told apart from all others, as there are differences which serve to mark them. The printers of the cradle age generally cast their own type and made their own punches. The latter were probably made of brass or copper, and the matrices of lead. In the Enschedé foundry, in Haarlem, are leaden matrices, said to be derived from punches of copper. They are now over four hundred years old. The metal cast into them only touched them at the

ABCDEFGHIJKLMN OPQRSTUVWXYZ

ABCDEFGHIJKLMN OPQRSTUVWXYZÆŒ

§ 1234567890 £ $\frac{111123357}{234834888}$

abcdefghijklmnopqrstvwxyz

V. B. MUNSON, SUCCESSOR TO
GEO. BRUCE'S SON & CO., 13 CHAMBERS STREET, NEW YORK.

TWENTY-TWO POINT.

DOUBLE SMALL PICA.

TWENTY-TWO POINT, No. 18.

1-NICK.

THE FIRST FOUNDERS had no common standard of height, thickness or other magnitude, and as a consequence the shape of the letters cut and cast by them differed very widely. It is easy in an old book to identify the type there used as having been employed in another book, and to state in what printing-office the work was prepared. To some extent the productions of two of the present foundries can

ABCDEFGHIJKLMNOPQR

ABCDEFGHIJKLMNOPQRSTUVWXYZ

\$ 1234567890 £

The first founders had no common standard of height or thickness or

ABCDEFGHIJKLMNOPQ

abcdefghijklmnopqrstvwxyz

V. B. MUNSON, SUCCESSOR TO
GEO. BRUCE'S SON & CO., 13 CHAMBERS STREET, NEW YORK.

TWENTY-TWO POINT.

DOUBLE SMALL PICA.

TWENTY-TWO POINT, No. 16.

1-NICK.

THE FIRST FOUNDERS had not a common standard of height, thickness or other magnitude, and consequently the shape of the letters cut and cast by them differed very widely. It is easy in an old book to identify the type there used as having been used in another book, and to state in what printing-office the work was prepared. To some extent the productions of two of the present foundries can still be told apart from all others, as there are differences which serve to mark them. The printers of the cradle age generally cast their own type and made their own punches. The latter were probably of brass or copper,

ABCDEFGHIJKLMN OPQRSTU

\$ 1234567890 £

abcdefghijklmnopqrstuvwxy z

V. B. MUNSON, SUCCESSOR TO
GEO. BRUCE'S SON & CO., 13 CHAMBERS STREET, NEW YORK.

TWENTY-EIGHT POINT.

DOUBLE ENGLISH.

TWENTY-EIGHT POINT, No. 13.

1-NICK.

MANY printing-offices of the sixteenth century had only three or four sizes of type, and a small quantity of each size was required. Enough for two or three quarto pages would do, if there were no more, and three or four cases full of

ABCDEFGHIJKLM

\$ 1234567890 £

Many printing-offices of the sixteenth century had

ABCDEFGHIJ

abcdefghijklmnopqrstuv

V. B. MUNSON, SUCCESSOR TO
GEO. BRUCE'S SON & CO., 13 CHAMBERS STREET, NEW YORK.

TWENTY-EIGHT POINT.
DOUBLE ENGLISH.

TWENTY-EIGHT POINT, No. 16.

1-NICK.

THE first founders had no common standard of height or thickness or other magnitude, and consequently the shape of the letters cut and cast by them differed very widely. It is easy in an old book to recognize the type there used as having been employed in another book, and even to name the printing-office in which the work

ABCDEFGHIJKLM

§ 1234567890 £

abcdefghijklmnopqrstuvwx

V. B. MUNSON, SUCCESSOR TO
GEO. BRUCE'S SON & CO., 13 CHAMBERS STREET, NEW YORK.

THIRTY-SIX POINT.

DOUBLE GREAT PRIMER.

THIRTY-SIX POINT, No. 13.

1-NICK.

ALL the work done
by the early printers
was with large type.
Many difficulties of
a mechanical nature
were thus overcome,
particularly that of

ABCDEFGHIJK

\$ 1234567 £

*All the work done by
the early printer was*

abcdefghijklmnop

V. B. MUNSON, SUCCESSOR TO
GEO. BRUCE'S SON & CO., 13 CHAMBERS STREET, NEW YORK.

THIRTY-SIX POINT.

DOUBLE GREAT PRIMER.

THIRTY-SIX POINT, No. 16.

1-NICK.

THE first step in type-making is the preparation of the punch. A punch is simply a type in steel; it must be in that metal, as it is only used to be driven into a copper plate, and it must be perfect in face

ABCDEFGHIJK

\$ 1234567890 £

abcdefghijklmnopqrst

V. B. MUNSON, SUCCESSOR TO
GEO. BRUCE'S SON & CO., 13 CHAMBERS STREET, NEW YORK.

FORTY-EIGHT POINT.

FOUR LINE PICA.

FORTY-EIGHT POINT, No. 13.

1-NICK.

THE workman
receives his idea
from a drawing
supplied by the
master founder,
or else is given a
A B C D E F G H
\$ 1 2 3 4 £
abcd efghijklmn

V. B. MUNSON, SUCCESSOR TO
GEO. BRUCE'S SON & CO., 13 CHAMBERS STREET, NEW YORK.

FORTY-EIGHT POINT.

FOUR LINE PICA.

FORTY-EIGHT POINT, No. 16.

1-NICK.

THE metal in
type is a mix-
ture of lead, tin
and antimony.
Copper is also
supposed to be
A B C D E F
\$ 1 2 3 £
a b c d e f g h i j k l

V. B. MUNSON, SUCCESSOR TO
GEO. BRUCE'S SON & CO., 13 CHAMBERS STREET, NEW YORK.

SIXTY POINT.

FIVE LINE PICA.

5 a 5 A—28 lb.

SIXTY POINT, No. 13.

\$13.50.

UNION
Dry Goods
Store 7

5 a 5 A—28 lb.

SIXTY POINT ITALIC, No. 13.

\$13.50.

CAST ON SLANTING BODY, SO THAT NO LETTER OVERHANGS; THEY ARE, THEREFORE, AS STRONG AS ROMAN TYPE.

BRASS
Rules and
Circles 8

V. B. MUNSON, SUCCESSOR TO
GEO. BRUCE'S SON & CO., 13 CHAMBERS STREET, NEW YORK.

EIGHTY-FOUR POINT.

SEVEN LINE PICA.

4 a 4 A—45 lb.

EIGHTY-FOUR POINT, No. 13.

\$21.60.

OUR
Home 5

4 a 4 A—51 lb.

EIGHTY-FOUR POINT ITALIC, No. 13.

\$24.50.

CAST ON SLANTING BODY, SO THAT NO LETTER OVERHANGS; THEY ARE, THEREFORE, AS STRONG AS ROMAN TYPE.

AND
Book 7

V. B. MUNSON, SUCCESSOR TO
GEO. BRUCE'S SON & CO., 13 CHAMBERS STREET, NEW YORK.

SEVENTY-TWO POINT.

SIX LINE PICA.

5 a 5 A—33 lb.

SEVENTY-TWO POINT, No. 16.

\$15.85.

BOLD
Romans 6

ONE HUNDRED AND EIGHT POINT.

NINE LINE PICA.

4 a 4 A—60 lb.

ONE HUNDRED AND EIGHT POINT, No. 16.

\$28.80.

THE
Time 7

V. B. MUNSON, SUCCESSOR TO
GEO. BRUCE'S SON & CO., 13 CHAMBERS STREET, NEW YORK.

ONE HUNDRED AND TWENTY POINT.

TEN LINE PICA.

4 a 4 A—74 lb.

ONE HUNDRED AND TEN POINT, No. 13.

\$35.50.

EMER

Bon 5

4 a 4 A—86 lb.

ONE HUNDRED AND TEN POINT ITALIC, No. 13.

\$41.00.

CAST ON SLANTING BODY, SO THAT NO LETTER OVERHANGS; THEY ARE, THEREFORE, AS STRONG AS ROMAN TYPE.

The 7

V. B. MUNSON, SUCCESSOR TO
GEO. BRUCE'S SON & CO., 13 CHAMBERS STREET, NEW YORK.

THE FIRST FOUNDERS had not a common standard of height, thickness or other magnitude, and consequently the shape of the letters cut and cast by them differed very widely. It is easy in an old book to identify the type used as having been employed in another book, and to state in what printing office the work was prepared. To some extent the productions of two of the present foundries can still be told apart from all others, as there are differences which serve to mark them. The printers of the cradle age generally cast their own type and made their own punches. The latter were probably of brass or copper, and the matrices

ABCDEFGHIJKLMNOPQRST

ABCDEFGHIJKLMNOPQRSTUVWXYZ

\$ 1234567890 £ $\frac{111123357}{234834888}$

The first founders had no common standard of height, thickness or other magnitude, and consequently the shape of the letters cut and

ABCDEFGHIJKLMNOPQ

abcdefghijklmnpqrstuvwxyz

THE first step in type-making is the preparation of the punch. This is simply a type in steel; it must be of that metal, for it is only used to be driven into a copper plate, and it must be perfect in face, for the cast reproductions imitate it faithfully. The workman gets his idea from a rough drawing made by the master founder, or from examination of a specimen, which he is told to imitate with or without changes. Usually speaking, if it is a new series, the letters are first cut on long primer or pica, and then others are made

ABCDEFGHIJKLMNO P Q

\$ 1234567890 £

The first step in type-making is the preparation of the punch. This is

ABCDEFGHIJKLMNO P

abcdefghijklmnopqrstuvwxy z

THE first step in type-making is the preparation of the punch. This is simply a type in steel; it must be of that metal, for it is used to be driven into a copper plate, and it must be perfect in face, for the cast reproductions imitate it faithfully. The workman gets his idea from a rough drawing by the master founder, or from examination of a specimen, which he is told to imitate

ABCDEFGHIJKLMNO

\$ 1234567890 £

The first step in type-making is the preparation of the punch, a

ABCDEFGHIJKLM

abcdefghijklmnopqrstvwxyz

MANY printing-offices of the sixteenth century had only three or four sizes of type, and a small quantity of each size was required. Sufficient for two or three quarto pages would do, if there were not more, and three or four cases full of type was considered ample

ABCDEFGHIJKLMN

\$ 1234567890 £

Many printing-offices of the sixteenth century had

ABCDEFGHIJKL

abcdefghijklmnopqrstuv

THE first step in type-making is the preparation of the punch. The punch is simply a type in steel. It must be of steel, for it is only used to be driven into a copper plate, and it should be perfect in face, for

ABCDEFGHIJKLM

\$ 1234567890 £

The first step in type-

ABCDEFGHIJ

abcdefghijklmnop

**IN America the first
journal appeared in
Boston, on the 25th
of September, 1690.
It contained reading
matter which caused
the General Court to
issue an order for its**

ABCDEFGHIJ

\$ 1234567890 £

In America the first

ABCDEFGHI

abcdefghijklmnopq

NEW type has, or
should have, all of
its fine lines intact.
Its beauty is some-
what marred after
being subjected to
about twenty-nine

ABCDEFGHIJ

\$1234567890£

New type has, or

ABCDEFGHIJ

abcdefghijklmno

**THE first daily
in America was
the Advertiser,
begun in Phila-
delphia in July,
1784. Another**

ABCDEFGHI

\$ 12345678 £

The first paper

ABCDEFGHI

abcdefghijklm

BOOK AND NEWSPAPER FACES--OLD STYLE.

**2-POINT LEADS USED
THROUGHOUT.....**

FIVE POINT, NO. 20 PEARL.

2-NICK.

THE FIRST FOUNDERS had no common standard of height, thickness or other magnitude, and consequently the shape of the letters cut and cast by them differed very widely. It is easy in an old book to identify the type there used as having been employed in another book, and to state in what printing-office the work was prepared. To some extent the productions of two of the present foundries can still be told apart from all others, as there are differences which serve to mark them. The printers of the cradle age generally cast their own type and made their own punches. The latter were probably of brass or copper, and the matrices of lead. In the Enschedé foundry, in Haarlem, are leaden matrices, said to be derived from punches of copper. They are now over four hundred years old. The metal cast into them only touched them at the end of each type, and was chilled as soon as it touched the leaden plate, leaving this intact. They were also obliged to make their own ink and construct their own presses. Type-founding seems to have been the first of the typographic processes which separated from the others and was carried on as a separate trade. Prior to this a printer was obliged to cut his own punches, fit up his matrices and do his own casting. It is true the number of characters employed with a certain size

ABCDEFGHIJKLMN O PQRSTU VWXYZÆ&

ABCDEFGHIJKLMN O PQRSTU VWXYZÆ

\$ 1234567890 £ ½¼⅓⅒⅑⅐⅏ⅎ⅍⅌⅋⅊ⅉⅈⅇⅆⅅ⅄⅃⅂⅁

The first founders had no common standard of height, thickness or other magnitude, and consequently the shape of the letters cut and cast by them differed very widely. It is easy in an old book to identify the type there used as

ABCDEFGHIJKLMN O PQRSTU VWXYZÆ&

abcdefghijklmnopqrstuvwxyz

FIVE POINT.

MY tongue-tied muse in manners hold her still,
While comments of your praise, richly compil'd,
Reserve their character with golden quill,
And precious phrase by all the muses fill'd.
I think good thoughts while others write good words,
And, like unlettered clerk, still cry "Amen"
To every hymn that able spirit affords,
In polish'd form of well-refined pen.
Hearing you prais'd, I say, "'Tis so, 'tis true."
And to the most of praise add something more;
But that is in my thought, whose love to you,
Though words come hindmost, holds his rank
before.
Then others for the breath of words respect,
Me for my dumb thoughts, speaking in effect.

SIX POINT.

THY gift, thy tables, are within my brain,
Full character'd with lasting memory,
Which shall above that idle rank remain,
Beyond all date, even to eternity:
Or at the least so long as brain and heart
Have faculty by nature to subsist;
Till each to raz'd oblivion yield his part
Of thee, thy record never can be missed.
That poor attention could not so much hold,
Nor need I tallies thy dear love to score;
Therefore to give them from me was I bold,
To trust those tables that receive thee more:
To keep an adjunct to remember thee,
Were to import forgetfulness in me.

SIX POINT, NO. 20 NONPAREIL.

2-NICK.

THE FIRST FOUNDERS had no common standard of height, thickness or other magnitude, and consequently the shape of the letters cut and cast by them differed very widely. It is easy in an old book to identify the type there used as having been employed in another book, and to state in what printing-office the work was prepared. To some extent the productions of two of the present foundries can still be told apart from all others, as there are differences which serve to mark them. The printers of the cradle age generally cast their own type and made their own punches. The latter were probably of brass or copper, and the matrices of lead. In the Enschedé foundry, in Haarlem, are leaden matrices, said to be derived from punches of copper. They are now over four hundred years old. The metal cast into them only touched them at the end of each type, and was chilled as soon as it touched the leaden plate, leaving this intact. They were also obliged to make their own ink and construct their own presses. Type-

ABCDEFGHIJKLMN O PQRSTU VWXYZÆ&

ABCDEFGHIJKLMN O PQRSTU VWXYZÆ

\$ 1234567890 £ ½¼⅓⅒⅑⅐⅏ⅎ⅍⅌⅋⅊ⅉⅈⅇⅆⅅ⅄⅃⅂⅁

The first founders had no common standard of height, thickness or other magnitude, and consequently the shape of the letters cut and cast by them differed very widely. It is easy in an old

ABCDEFGHIJKLMN O PQRSTU VWXYZÆ&

abcdefghijklmnopqrstuvwxyz

V. B. MUNSON, SUCCESSOR TO
GEO. BRUCE'S SON & CO., 13 CHAMBERS STREET, NEW YORK.

SEVEN POINT, NO. 20

'3-NICK.

MINION.

THE FIRST FOUNDERS had no common standard of height, thickness or other magnitude, and consequently the shape of the letters cut and cast by them differed very widely. It is easy in an old book to identify the type there used as having been employed in another book, and to state in what printing-office the work was prepared. To some extent the productions of two of the present foundries can still be told apart from all others, as there are differences which serve to mark them. The printers of the cradle age generally cast their own type and made their own punches. The latter were probably of brass or copper, and the matrices of lead. In the Enschedé foundry, in Haarlem, are leaden matrices, said to

ABCDEFGHIJKLMNPOQRSTUVWXYZÆŒ&

ABCDEFGHIJKLMNPOQRSTUVWXYZÆŒ

\$ 1234567890 £ ½ ⅓ ¼ ⅕ ⅙ ⅗ ⅘ ⅞ ⅝

The first founders had no common standard of height, thickness or other magnitude, and consequently the shape of the letters cut and cast by them differed very widely. It is easy

ABCDEFGHIJKLMNPOQRSTUVWXYZÆŒ&

abcdefghijklmnopqrstuvwxyz

<p>EVEN as the sun with purple-colour'd face Had ta'en his last leave of the weeping morn, Rose-cheeked Adonis hied him to the chase; Hunting he lov'd, but love he laughed to scorn; Sick-thoughted Venus makes amain unto him, And like a bold-fac'd suitor 'gins to woo him.</p>	<p>SEVEN POINT</p>
<p>“Thrice fairer than myself,” thus she began, “The field's chief flower, sweet above compare, Stain to all nymphs, more lovely than a man, More white and red than doves or roses are: Nature that made thee, with herself at strife, Saith that the world hath ending with thy life.</p>	<p>EIGHT POINT</p>

EIGHT POINT, NO. 20

2-NICK.

BREVIER.

THE FIRST FOUNDERS had no common standard of height, thickness or other magnitude, and consequently the shape of the letters cut and cast by them differed very widely. It is easy in an old book to identify the type there used as having been employed in another book, and to state in what printing-office the work was prepared. To some extent the productions of two of the present foundries can still be told apart from all others, as there are differences which serve to mark them. The printers of the cradle age generally cast their own type and made their own punches. The latter were probably of brass or copper, and the matrices of lead. In the Enschedé foundry,

ABCDEFGHIJKLMNPOQRSTUVWXYZÆŒ&

ABCDEFGHIJKLMNPOQRSTUVWXYZÆŒ

\$ 1234567890 £ ½ ⅓ ¼ ⅕ ⅙ ⅗ ⅘ ⅞ ⅝

The first founders had no common standard of height, thickness or other magnitude, and consequently the shape of the letters cut and cast by them differed

ABCDEFGHIJKLMNPOQRSTUVWXYZÆŒ&

abcdefghijklmnopqrstuvwxyz

V. B. MUNSON, SUCCESSOR TO
 GEO. BURCE'S SON & CO., 13 CHAMBERS STREET, NEW YORK.

NINE POINT, NO. 20

3-NICK.

BOURGEOIS.

THE FIRST FOUNDERS had no common standard of height, thickness or other magnitude, and consequently the shape of the letters cut and cast by them differed very widely. It is easy in an old book to identify the type there used as having been employed in another book, and to state in what printing-office the work was prepared. To some extent the productions of two of the present foundries can still be told apart from all others, as there are differences which serve to mark them. The printers of the cradle age generally cast their own type and made their own punches. The latter were probably of brass or copper, and the matrices of lead. In the Enschedé foundry, in Haarlem, are leaden matrices, said to be derived from punches of copper. They are now over four hundred years old. The metal cast into them only touched them at the end of each type, and was chilled as soon as

ABCDEFGHIJKLMNOPQRSTUVWXYZÆ&

ABCDEFGHIJKLMNOPQRSTUVWXYZÆ

\$ 1234567890 £ ½ ⅓ ¼ ⅙ ⅛ ⅔ ¾ ⅜ ⅝ ⅞

The first founders had no common standard of height, thickness or other magnitude, and consequently the shape of the letters cut and cast by them differed widely. It is easy in an old book to identify the type there used as having been employed in another book, and to

ABCDEFGHIJKLMNOPQRSTUVWXYZÆ&

abcdefghijklmnopqrstuvwxy

TEN POINT, NO. 20

2-NICK.

LONG PRIMER.

THE FIRST FOUNDERS had no common standard of height, thickness or other magnitude, and consequently the shape of the letters cut and cast by them differed widely. It is easy in an old book to identify the type there used as having been employed in another book, and to state in what printing-office the work was prepared. To some extent the productions of two of the present foundries can still be told apart from all others, as there are differences which serve to mark them. The printers of the cradle age generally cast their own type and made their own punches. The latter were probably of brass or copper, and the matrices of lead. In the Enschedé foundry, in Haarlem, are leaden matrices, said to be derived from punches of copper. They are now over four hundred years old. The

ABCDEFGHIJKLMNOPQRSTUVWXYZÆ&

ABCDEFGHIJKLMNOPQRSTUVWXYZÆ

\$ 1234567890 £ ½ ⅓ ¼ ⅙ ⅛ ⅔ ¾ ⅜ ⅝ ⅞

The first founders had no common standard of height, thickness or other magnitude, and consequently the shape of the letters cut and cast by them differed very widely. It is easy in an old book to

ABCDEFGHIJKLMNOPQRSTUVWXYZÆ&

abcdefghijklmnopqrstuvwxy

V. B. MUNSON, SUCCESSOR TO
GEO. BRUCE'S SON & CO., 13 CHAMBERS STREET, NEW YORK.

ELEVEN POINT, NO. 20

3-NICK.

SMALL PICA.

THE FIRST FOUNDERS had no common standard of height, thickness or other magnitude, and consequently the shape of the letters cut and cast by them differed very widely. It is easy in an old book to identify the type there used as having been employed in another book, and to state in what printing-office the work was prepared. To some extent the productions of two of the present foundries can still be told apart from all others, as there are differences which serve to mark them. The printers of the cradle age generally cast their own type and made their

ABCDEFGHIJKLMN OPQRSTUVWXYZÆŒ&

ABCDEFGHIJKLMN OPQRSTUVWXYZÆŒ

\$ 1234567890 £ ½ ⅓ ¼ ⅙ ⅛ ⅔ ¾ ⅜ ⅝ ⅞

The first founders had no common standard of height, thickness or other magnitude, and consequently the shape of the letters cut and cast by them differed very widely. It is easy

ABCDEFGHIJKLMN OPQRSTUVWXYZÆŒ&

abcdefghijklmnopqrstuvwxy z

TWELVE POINT, NO. 20

2-NICK.

PICA.

THE FIRST FOUNDERS had no common standard of height, thickness or other magnitude, and consequently the shape of the letters cut and cast by them differed very widely. It is easy in an old book to identify the type there used as having been employed in another book, and to state in what printing-office the work was prepared. To some extent the productions of two of the present foundries can still be told apart from all others, as there

ABCDEFGHIJKLMN OPQRSTUVWXYZÆŒ&

ABCDEFGHIJKLMN OPQRSTUVWXYZÆŒ

\$ 1234567890 £ ½ ⅓ ¼ ⅙ ⅛ ⅔ ¾ ⅜ ⅝ ⅞

The first founders had no common standard of height, thickness or other magnitude, and consequently the

ABCDEFGHIJKLMN OPQRSTUVWXYZÆŒ&

abcdefghijklmnopqrstuvwxy z

V. B. MUNSON, SUCCESSOR TO
GEO. BRUCE'S SON & CO., 13 CHAMBERS STREET, NEW YORK.

THE FIRST FOUNDERS had not a common standard of height, thickness or other magnitude, and consequently the shape of the letters cut and cast by them differed very widely. It is easy in an old book to identify the type there used as having been used in another book, and to state in what printing-office the work was prepared. To some extent the productions of two of the present foundries can still be told apart from all others, as there are differences which serve to mark them. Printers of the cradle age generally cast their own type and made their own punches. The latter were probably of brass or copper, and the matrices of lead. In the Enschedé foundry, Haarlem, are leaden matrices, said to be derived from punches of copper. They are now over four hundred years old. The metal cast into them only touched them at the end of each type, and was chilled as soon as it touched the leaden plate, leaving this intact. They were also obliged to make their own inks and construct their own presses. Type-founding seems to have been the first of the typographic processes which

ABCDEFGHIJKLMNOPQRSTUVWXYZ

ABCDEFGHIJKLMNOPQRSTUVWXYZÆŒ

\$ 1234567890 £ 1/2 1/3 1/4 1/6 1/8 2/3 3/4 3/8 5/8 7/8

The first founders had no common standard of height, thickness or other magnitude, and consequently the shape of the letters cut and cast by them differed very widely. It is easy in an old

ABCDEFGHIJKLMOPQRSTUVWXYZ

abcdefghijklmnopqrstuvwxy

THE FIRST FOUNDERS had not a common standard of height, thickness or other magnitude, and consequently the shape of the letters cut and cast by them differed very widely. It is quite easy in an old book to identify the type there used as having been employed in another book, and to state in what printing-office the work was prepared. To some extent the productions of two of the present foundries can still be told apart from all others, as there are differences by which they can be recognized. Printers of the cradle age generally cast their own type and made their own punches. The latter were probably of brass or copper, and the matrices of lead. In the Enschedé foundry

ABCDEFGHIJKLMNOPQRSTU

ABCDEFGHIJKLMNOPQRSTUVWXYZÆŒ

\$ 1234567890 £

The first founders had no common standard of height, thickness or other magnitude, and consequently the shape of the letters cut and

ABCDEFGHIJKLMNOPQRS

abcdefghijklmnopqrstvwxyz

THE FIRST STEP in type-founding is the preparation of the punch. This is a type in steel; it must be in that metal, for it is only used to be driven into a copper plate, and it must be perfect in face, for the cast reproductions imitate it faithfully. The workman receives his idea from a rough drawing of the master founder, or from examination of a specimen, which he is instructed to imitate with or without changes. Usually speaking,

ABCDEFGHIJKLMNO P Q

ABCDEFGHIJKLMNO P Q R S T U

\$ 1 2 3 4 5 6 7 8 9 0 £

The first step in type-founding is the making of the punch. This is

ABCDEFGHIJKLMN

abcdefghijklmnopqrstvwxyz

THE FIRST STEP in type-
founding is the prepara-
tion of the punch, which
is simply a type in steel.
It must be made of that
metal, as it is only used

ABCDEFGHIJKL

ABCDEFGHIJKLMNO P Q

\$ 1234567890 £

Printers in 17th century

ABCDEFGHI

abcdefghijklmnopqrstu

TEN POINT WASHINGTON OLD STYLE--No. 22

LONG PRIMER.

THE FIRST FOUNDERS had no common standard of height, thickness or other magnitude, and consequently the shape of the letters cut and cast by them differed very widely. It is easy in an old book to identify the type there used as having been employed in another book, and to state in what printing-office the work was prepared. To some extent the productions of two of the present foundries can still be told apart from all others, as there are differences which serve to mark them. The printers of the cradle age generally cast their own type and made their own punches. The latter were probably of brass or copper, and the matrices of lead. In the Enschedé foundry, in Haarlem, are leaden matrices, said to be derived from punches of copper. They are now over four hundred years old. The metal cast into them only touched them at the end of each type, and was chilled as soon as it touched the leaden plate, leaving this intact. They were also obliged to make their own ink and construct their own presses. Type-founding seems to have been the first of the typographic processes which separated from the others and was carried on as a separate trade. Prior to this a printer was obliged to cut his own punches, fit up his matrices and do his own casting. It is true the number of characters employed with a certain size was small, not much exceeding one hundred; the type was large, thus obviating the necessity of so great an accuracy as was afterwards requisite, and few faces were necessary. Many printing-offices of the sixteenth century had only four or five sizes of type. The quantity required was also small. Enough for two quarto pages would do, if there were no more, and three or four cases full of type were amply sufficient. A printer could sometimes buy the stock of another who was declining business; he might induce a friend in another town to cast letter for him, and he could take

ABCDEFGHIJKLMN OPQRSTUVWXYZÆ&

ABCDEFGHIJKLMN OPQRSTUVWXYZÆ&

\$ 1234567890 £ ½ ⅓ ¼ ⅕ ⅙ ⅔ ¾ ⅞ ⅝ ⅞

The first founders had no common standard of height, thickness, or other magnitude, and consequently the shape of the letters cut and cast by them differed very widely. It is easy in an old book to identify the type there used as having been employed in another

ABCDEFGHIJKLMN OPQRSTUVWXYZÆ&

1234567890\$

abcdefghijklmnopqrstuvwxy z

☞ OTHER SIZES OF THIS SERIES IN PREPARATION

V. B. MUNSON. SUCCESSOR TO
GEO. BRUCE'S SON & CO., 13 CHAMBERS STREET, NEW YORK.

STYLE 100.

20 A—2 lb. 4 oz.

10-POINT OLD STYLE, No. 100.

\$1.65.

THE STUDDED BRIDLE ON A RUGGED BOUGH
NIMBLY SHE FASTENS I234

15 A—2 lb. 6 oz.

12-POINT OLD STYLE, No. 100.

\$1.55.

FED THEM WITH HIS SIGHT, THEY
HIM WITH BERRIES I234

15 A—4 lb. 2 oz.

16-POINT OLD STYLE, No. 100.

\$2.50.

HERE OVERCOME, AS ONE
FULL OF DESPAIR I234

12 A—5 lb. 12 oz.

20-POINT OLD STYLE, No. 100.

\$3.45.

DID YOU NOT NAME
A TEMPEST I234

10 A—6 lb. 12 oz.

24-POINT OLD STYLE, No. 100.

\$3.80.

IT WILL BE FOR
THY GOOD I2

8 A—11 lb.

36-POINT OLD STYLE, No. 100.

\$6.15.

FROM HIM I
COME I2

V. B. MUNSON, SUCCESSOR TO
GEO. BRUCE'S SON & CO., 13 CHAMBERS STREET, NEW YORK.

STYLE 654.

60 a 30 A—2 lb. 2 oz. 6-POINT ELZEVIR ITALIC, No. 654. \$2.45.

WHEREFORE REJOICE? WHAT CONQUEST BRINGS HE HOME?

What tributaries follow him to Rome, to grace in captive bonds his chariot wheels? You blocks, you stones, you worse than senseless things! O, you hard hearts, you cruel men of Rome, knew you not Pompey? Many a time and oft have you 1234567890

ABCDEFGHIJKLMNOPQRSTUVWXYZÆ&
ABCDEFGHIJKLMNŒOPQRSTUVWXYZ

60 a 30 A—3 lb. 2 oz. 8-POINT ELZEVIR ITALIC, No. 654. \$2.80.

CLIMBED UP TO WALLS AND BATTLEMENTS, TO

Towers and windows, yea, to chimney-tops, your infants in your arms, and there have sat the livelong day, with patient expectation, to see great Pompey pass the streets of Rome; and when you saw his chariot appear, 13467890

ABCDEFGHIJKLMNOPQRSTUVWXYZÆ&
ABCDEFGHIJKLMNŒOPQRSTUVWXYZ

40 a 20 A—3 lb. 2 oz. 10-POINT ELZEVIR ITALIC, No. 654. \$2.30.

HAVE YOU NOT MADE AN UNIVERSAL SHOUT,

That Tiber trembled underneath her banks, to hear the replication of your sounds, made in her concave shores? And do you not now put on your best attire? And do 1234567890

ABCDEFGHIJKLMNOPQRSTUVWXYZÆ&
ABCDEFGHIJKLMNŒOPQRSTUVWXYZ

30 a 15 A—4 lb. 12-POINT ELZEVIR ITALIC, No. 654. \$2.55.

YOU NOW CULL OUT A HOLIDAY?

And do you now strew flowers in his way, that comes in triumph over Pompey's blood? Be gone!

Run to your houses! 1234567890

ABCDEFGHIJKLMNOPQRSTUVWXYZÆ&
ABCDEFGHIJKLMNŒOPQRSTUVWXYZ

V. B. MUNSON, SUCCESSOR TO
GEO. BRUCE'S SON & CO., 13 CHAMBERS STREET, NEW YORK.

STYLE 654.

25 a 12 A—6 lb. 8 oz.

18-POINT ELZEVIR ITALIC, No. 654.

\$3.90.

PEACE! CÆSAR SPEAKS.

*Stand you directly in Antonius' way when
he doth run his course. 1234567890*

ABCDEFGHIJKLMN O PQRST

UVWXYZÆŒ&

ABDE&fMnPRtUw

25 a 12 A—10 lb. 4 oz.

22-POINT ELZEVIR ITALIC, No. 654.

\$5.75.

I KNOW NOT, SIR.

*How that may change his mood;
that's the question. 123*

as es is us

15 a 8 A—15 lb. 6 oz.

36-POINT ELZEVIR ITALIC, No. 654.

\$8.60.

WHO'S THIS?

*What a blunt fellow is he
grown to be! 12346*

as es is us

V. B. MUNSON, SUCCESSOR TO
GEO. BRUCE'S SON & CO., 13 CHAMBERS STREET, NEW YORK.

STYLE 90.

FIVE-AND-A-HALF POINT GERMAN, No. 90.

3-NICK.

Schrift (Lettern, Typen), metallene Buchstaben, welche zum Drucken eines Buches gebraucht werden. Die Schrift besteht aus vierseitigen, etwa 1 Zoll langen Stiften, auf denen oben der Buchstabe erhaben, aber links, gegossen ist. Die untere Seite des Stifts heißt der Fuß, der Unterschied zwischen Fuß und der obern Seite die Höhe. Die Entfernung von der untern Seite des Buchstabens bis zu dessen oberen (Stärke) und von einer Seite zur andern (Breite) heißt Schriftregel. Bücher in Deutscher Sprache pflegen in der edigen Fraktur, mit dickeren Strichen fette Schrift genannt, gedruckt zu werden, welche von der alten Mönchschrift stammt und rechtwinkelig auf den Zeilen steht. Auch die Gothische Schrift ist eine nach Mönchsform gegossene, mit einigen Zierrathen versehene fette Fraktur. Sie wurde durch die Titel englischer Bücher, wo die Hauptzeile und der Verlagsort oft aus ihr gedruckt sind, in Frankreich und seit 1824 auch in Deutschland gewöhnlich, aber in beiden Ländern zur Neugothischen oder Pariser Gothischen vereinfacht. Zuweilen sind die größeren Gattungen derselben mustert. Auch Kanzleischrift hat man, welche schön verziert in neuerer Zeit vorhanden und besser zu Titel- und Hauptzeilen bestimmt ist. Der Gegensatz zu Fraktur ist die Antiqua, welche die Form der lateinischen Schrift mehr beibehalten hat; mit ihr werden lateinische, italienische, französische, englische, spanische, portugiesische, holländische, ungarische, polnische ic., jetzt auch dänische, schwedische, böhmische, lithauische Bücher, selbst viele deutsche, besonders wissenschaftliche Werke gedruckt. Die von den Deutschen A. Pannartz und K. Schöynheim um 1467 in Rom erfundene, von Aldus Manutius verbesserte Antiqua zerfällt wieder in eigentliche Antiqua, bei welcher die Grundstriche rechtwinkelig auf der Zeile stehen, und in Curfiv, bei welcher die Buchstaben nach der rechten Seite überhängen. Die Fraktur, Antiqua und Curfiv werden auch als fette und halbfette

A B C D E F G H I J K L M N O P Q R S T U V W X Y Z Ä Ö Ü

♠ ♡ ♢ ♣ ♤ ♥ ♦ ♧ ♨ ♩ ♪ ♫ ♬ ♭ ♮ ♯ ♮ ♭ ♭

abcdefghijklmnopqrstuvwxyz

§ 1234567890 £

SIX-POINT GERMAN, No. 90.

2-NICK.

Schrift (Lettern, Typen), metallene Buchstaben, welche zum Drucken eines Buches gebraucht werden. Die Schrift besteht aus vierseitigen, etwa 1 Zoll langen Stiften, auf denen oben der Buchstabe erhaben, aber links, gegossen ist. Die untere Seite des Stifts heißt der Fuß, der Unterschied zwischen Fuß und der obern Seite die Höhe. Die Entfernung von der untern Seite des Buchstabens bis zu dessen oberen (Stärke) und von einer Seite zur andern (Breite) heißt Schriftregel. Bücher in Deutscher Sprache pflegen in der edigen Fraktur, mit dickeren Strichen fette Schrift genannt, gedruckt zu werden, welche von der alten Mönchschrift stammt und rechtwinkelig auf den Zeilen steht. Auch die Gothische Schrift ist eine nach Mönchsform gegossene, mit einigen Zierrathen versehene fette Fraktur. Sie wurde durch die Titel englischer Bücher, wo die Hauptzeile und der Verlagsort oft aus ihr gedruckt sind, in Frankreich und seit 1824 auch in Deutschland gewöhnlich, aber in beiden Ländern zur Neugothischen oder Pariser Gothischen vereinfacht. Zuweilen sind die größeren Gattungen derselben mustert. Auch Kanzleischrift hat man, welche schön verziert in neuerer Zeit vorhanden und besser zu Titel- und Hauptzeilen bestimmt ist. Der Gegensatz zu Fraktur ist die Antiqua, welche die Form der lateinischen Schrift mehr beibehalten hat; mit ihr werden lateinische, italienische, französische, englische, spanische, portugiesische, holländische, ungarische, polnische ic., jetzt auch dänische, schwedische, böhmische, lithauische Bücher, selbst viele deutsche, bes. wissenschaftliche Werke gedruckt. Die von den Deutschen A. Pannartz und K. Schöynheim um 1467 in Rom erfundene, von Aldus Manutius verbesserte Antiqua zerfällt wieder in eigentliche Antiqua, bei welcher die Grundstriche rechtwinkelig auf der Zeile stehen, und in Curfiv, bei welcher die Buchstaben nach der rechten Seite überhängen. Die Fraktur, Antiqua und Curfiv werden auch als fette und halbfette

A B C D E F G H I J K L M N O P Q R S T U V W X Y Z Ä Ö Ü

♠ ♡ ♢ ♣ ♤ ♥ ♦ ♧ ♨ ♩ ♪ ♫ ♬ ♭ ♮ ♯ ♮ ♭ ♭

abcdefghijklmnopqrstuvwxyz

§ 1234567890 £

SEVEN-POINT GERMAN, No. 90.

3-NICK.

Schrift (Lettern, Typen), metallene Buchstaben, welche zum Drucken eines Buches gebraucht werden. Die Schrift besteht aus vierseitigen, etwa 1 Zoll langen Stiften, auf denen oben der Buchstabe erhaben, aber links, gegossen ist. Die untere Seite des Stifts heißt der Fuß, der Unterschied zwischen Fuß und der obern Seite die Höhe. Die Entfernung von der untern Seite des Buchstabens bis zu dessen oberen (Stärke) und von einer Seite zur andern (Breite) heißt Schriftregel. Bücher in Deutscher Sprache pflegen in der edigen Fraktur, mit dickeren Strichen fette Schrift genannt, gedruckt zu werden, welche von der alten Mönchschrift stammt und rechtwinkelig auf den Zeilen steht. Auch die Gothische Schrift ist eine nach Mönchsform gegossene, mit einigen Zierrathen versehene fette Fraktur. Sie wurde durch die Titel englischer Bücher, wo die Hauptzeile und der Verlagsort oft aus ihr gedruckt sind, in Frankreich und seit 1824 auch in Deutschland gewöhnlich, aber in beiden Ländern zur Neugothischen oder Pariser Gothischen vereinfacht. Zuweilen sind die größeren Gattungen derselben mustert. Auch Kanzleischrift hat man, welche schön verziert in neuerer Zeit vorhanden und besser zu Titel- und Hauptzeilen bestimmt ist. Der Gegensatz zu Fraktur ist die Antiqua, welche die Form der lateinischen Schrift mehr beibehalten hat; mit ihr werden lateinische, italienische, französische, englische, spanische, portugiesische, holländische, ungarische, polnische ic., jetzt auch dänische, schwedische, böhmische, lithauische Bücher, selbst viele deutsche, bes. wissenschaftliche Werke gedruckt. Die von den Deutschen A. Pannartz und K. Schöynheim um 1467 in Rom erfundene, von Aldus Manutius verbesserte Antiqua zerfällt wieder in eigentliche Antiqua, bei welcher die Grundstriche rechtwinkelig auf der Zeile stehen, und in Curfiv, bei welcher die Buchstaben nach der rechten Seite überhängen. Die Fraktur, Antiqua und Curfiv werden auch als fette und halbfette

A B C D E F G H I J K L M N O P Q R S T U V W X Y Z Ä Ö Ü

♠ ♡ ♢ ♣ ♤ ♥ ♦ ♧ ♨ ♩ ♪ ♫ ♬ ♭ ♮ ♯ ♮ ♭ ♭

abcdefghijklmnopqrstuvwxyz

§ 1234567890 £

V. B. MUNSON, SUCCESSOR TO
GEO. BRUCE'S SON & CO., 13 CHAMBERS STREET, NEW YORK.

STYLE 90.

EIGHT POINT GERMAN, No. 90.

2-NICK.

Schrift (Lettern, Typen), metallene Buchstaben, welche zum Drucken eines Buches gebraucht werden. Die Schrift besteht aus vierseitigen, etwa 1 Zoll langen Stiften, auf denen oben der Buchstabe erhaben, aber links, gegossen ist. Die untere Seite des Stifts heißt der Fuß, der Unterschied zwischen Fuß und der obern Seite die Höhe. Die Entfernung von der untern Seite des Buchstabens bis zu dessen oberen (Stärke) und von einer Seite zur andern (Breite) heißt Schriftkegel. Bücher in Deutscher Sprache pflegen in der edigen Fraktur, mit dickeren Strichen fette Schrift genannt, gedruckt zu werden, welche von der alten Mönchschrift stammt und rechtwinkelig auf den Zeilen steht. Auch die Gothische Schrift ist eine nach Mönchsform gegossene, mit einigen Zierrathen versehene fette Fraktur. Sie wurde durch die Titel englischer Bücher, wo die Hauptzeile und der Verlagsort oft aus ihr gedruckt sind, in Frankreich und seit 1824 auch in Deutschland gewöhnlich, aber in beiden Ländern zur Neugothischen oder Pariser Gothischen vereinfacht. Zuweilen sind die größeren Gattungen derselben musirt. Auch Kanzleischrift hat man, welche schön verziert in neuerer Zeit vorhanden und besser zu Titel- und Hauptzeilen bestimmt ist. Der Gegensatz zu Fraktur ist die Antiqua, welche die Form der lateinischen Schrift mehr beibehalten hat; mit ihr werden lateinische, italienische, französische, englische, spanische, portugiesische, holländische, ungarische, polnische u., jetzt auch dänische, schwedische, böhmische, lithauische Bücher, selbst viele deutsche, besonders wissenschaftliche Werke gedruckt. Die von den Deutschen A. Pannartz und K. Schwynheim um 1467 in Rom erfundene, von Aldus Manutius verbesserte Antiqua zerfällt wieder in eigentliche Antiqua, bei welcher die Grundstriche rechtwinkelig auf der Zeile stehen, und in Cursiv, bei welcher die Buchstaben

A B C D E F G H I J K L M N O P Q R S T U V W X Y Z Ä Ö Ü

♠ ♡ ♢ ♣ ♤ ♥ ♦ ♧ ♨ ♩ ♪ ♫ ♬ ♭ ♮ ♯ ♮

a b c d e f g h i j k l m n o p q r s t u v w x y z

§ 1 2 3 4 5 6 7 8 9 0 £

NINE POINT GERMAN, No. 90.

3-NICK.

Schrift (Lettern, Typen), metallene Buchstaben, welche zum Drucken eines Buches gebraucht werden. Die Schrift besteht aus vierseitigen, etwa 1 Zoll langen Stiften, auf denen oben der Buchstabe erhaben, aber links, gegossen ist. Die untere Seite des Stifts heißt der Fuß, der Unterschied zwischen Fuß und der obern Seite die Höhe. Die Entfernung von der untern Seite des Buchstabens bis zu dessen oberen (Stärke) und von einer Seite zur andern (Breite) heißt Schriftkegel. Bücher in Deutscher Sprache pflegen in der edigen Fraktur, mit dickeren Strichen fette Schrift genannt, gedruckt zu werden, welche von der alten Mönchschrift stammt und rechtwinkelig auf den Zeilen steht. Auch die Gothische Schrift ist eine nach Mönchsform gegossene, mit einigen Zierrathen versehene fette Fraktur. Sie wurde durch die Titel englischer Bücher, wo die Hauptzeile und der Verlagsort oft aus ihr gedruckt sind, in Frankreich und seit 1824 auch in Deutschland gewöhnlich, aber in beiden Ländern zur Neugothischen oder Pariser Gothischen vereinfacht. Zuweilen sind die größeren Gattungen derselben musirt. Auch Kanzleischrift hat man, welche schön verziert in neuerer Zeit vorhanden und besser zu Titel- und Hauptzeilen bestimmt ist. Der Gegensatz zu Fraktur ist die Antiqua, welche die Form der lateinischen Schrift mehr beibehalten hat; mit ihr werden lateinische, italienische, französische, englische, spanische, portugiesische,

A B C D E F G H I J K L M N O P Q R S T U V W X Y Z Ä Ö Ü

♠ ♡ ♢ ♣ ♤ ♥ ♦ ♧ ♨ ♩ ♪ ♫ ♬ ♭ ♮ ♯ ♮

a b c d e f g h i j k l m n o p q r s t u v w x y z

§ 1 2 3 4 5 6 7 8 9 0 £

V. B. MUNSON, SUCCESSOR TO
GEO. BRUCE'S SON & CO., 13 CHAMBERS STREET, NEW YORK.

STYLE 90.

TEN POINT GERMAN, No. 90.

2-NICK.

Schrift (Lettern, Typen), metallene Buchstaben, welche zum Drucken eines Buches gebraucht werden. Die Schrift besteht aus vierseitigen, etwa 1 Zoll langen Stiften, auf denen oben der Buchstabe erhaben, aber links, gegossen ist. Die untere Seite des Stifts heißt d. r. Fuß, der Unterschied zwischen Fuß und der obern Seite die Höhe. Die Entfernung von der untern Seite des Buchstabens bis zu dessen oberen (Stärke) und von einer Seite zur andern (Breite) heißt Schriftregel. Bücher in Deutscher Sprache pflegen in der edigen Fraktur, mit dickeren Strichen fette Schrift genannt, gedruckt zu werden, welche von der alten Mönchschrift stammt und rechtwinkelig auf den Zeilen steht. Auch die Gothische Schrift ist eine nach Mönchsform gegossene, mit einigen Zierrathen versehene fette Fraktur. Sie wurde durch die Titel englischer Bücher, wo die Hauptzeile und der Verlagsort oft aus ihr gedruckt sind, in Frankreich und seit 1824 auch in Deutschland gewöhnlich, aber in beiden Ländern zur Neugothischen oder Pariser Gothischen vereinfacht. Zuweilen sind die größeren Gattungen derselben mustert. Auch Kanzleischrift hat man, welche schön verziert in neuerer Zeit vorhanden und besser zu Titel- und Hauptzeilen bestimmt ist. Der Gegensatz zu

A B C D E F G H I J K L M N O P Q R S T U V W X Y Z Ä Ö Ü

ch d ll s s i i s s t t s s ä ö ü abcdefghijklmnopqrstuvwxyz \$ 1234567890 £

ELEVEN POINT GERMAN, No. 90.

3-NICK.

Schrift (Lettern, Typen), metallene Buchstaben, welche zum Drucken eines Buches gebraucht werden. Die Schrift besteht aus vierseitigen, etwa 1 Zoll langen Stiften, auf denen oben der Buchstabe erhaben, aber links, gegossen ist. Die untere Seite des Stifts heißt der Fuß, der Unterschied zwischen Fuß und der obern Seite die Höhe. Die Entfernung von der untern Seite des Buchstabens bis zu dessen oberen (Stärke) und von einer Seite zur andern (Breite) heißt Schriftregel. Bücher in Deutscher Sprache pflegen in der edigen Fraktur, mit dickeren Strichen fette Schrift genannt, gedruckt zu werden, welche von der alten Mönchschrift stammt und rechtwinkelig auf den Zeilen steht. Auch die Gothische Schrift ist eine nach Mönchsform gegossene, mit einigen Zierrathen versehene fette Fraktur. Sie wurde durch die Titel englischer Bücher, wo die Hauptzeile und der Verlagsort oft aus ihr gedruckt sind, in Frankreich und seit 1824 auch in Deutschland gewöhnlich, aber in beiden Ländern zur Neugothischen oder Pariser Gothischen vereinfacht. Zuweilen sind die größeren Gattungen

A B C D E F G H I J K L M N O P Q R S T U V W X Y Z Ä Ö Ü

ch d ll s s i i s s t t s s ä ö ü abcdefghijklmnopqrstuvwxyz \$ 1234567890 £

V. B. MUNSON, SUCCESSOR TO
GEO. BRUCE'S SON & CO., 13 CHAMBERS STREET, NEW YORK.

STYLE 90.

TWELVE POINT GERMAN, No. 90.

2-NICK.

Schrift (Lettern, Typen), metallene Buchstaben, welche zum Drucken eines Buches gebraucht werden. Die Schrift besteht aus vierseitigen, etwa 1 Zoll langen Stiften, auf denen oben der Buchstabe erhaben, aber links, gegossen ist. Die untere Seite des Stifts heißt der Fuß, der Unterschied zwischen Fuß und der obern Seite die Höhe. Die Entfernung von der untern Seite des Buchstabens bis zu dessen oberer (Stärke) und von einer Seite zur andern (Breite) heißt Schriftkegel. Bücher in Deutscher Sprache pflegen in der edigen Fraktur, mit dickeren Strichen fette Schrift genannt, gedruckt zu werden, welche von der alten Mönchschrift stammt und rechtwinkelig auf den Zeilen steht. Auch die Gothische Schrift ist eine nach Mönchsform gegossene, mit einigen Zierrathen versehene fette Fraktur. Sie wurde durch die Titel

A B C D E F G H I J K L M N O P Q R S T U V W X Y Z Ä Ö Ü

h c k l s s i f f s t s s ä ö ü a b c d e f g h i j k l m n o p q r s t u v w x y z \$ 1 2 3 4 5 6 7 8 9 0 £

FOURTEEN POINT GERMAN, No. 90.

1-NICK.

Schrift (Lettern, Typen), metallene Buchstaben, welche zum Drucken eines Buches gebraucht werden. Die Schrift besteht aus vierseitigen, etwa 1 Zoll langen Stiften, auf denen oben der Buchstabe erhaben, aber links, gegossen ist. Die untere Seite des Stifts heißt der Fuß, der Unterschied zwischen Fuß und der obern Seite die Höhe. Die Entfernung von der untern Seite des Buchstabens bis zu dessen oberer (Stärke) und von einer Seite zur andern (Breite) heißt Schriftkegel. Bücher in Deutscher Sprache pflegen in der edigen Fraktur, mit dickeren Strichen fette Schrift genannt, gedruckt zu werden, welche von der alten Mönchs-

A B C D E F G H I J K L M N O P Q R S T U V W X Y Z Ä Ö Ü

a b c d e f g h i j k l m n o p q r s t u v w x y z

h c k l s s i f f s t s s ä ö ü \$ 1 2 3 4 5 6 7 8 9 0 £

V. B. MUNSON, SUCCESSOR TO
GEO. BRUCE'S SON & CO., 13 CHAMBERS STREET, NEW YORK.

STYLE 90.

SIXTEEN POINT GERMAN, No. 90.

1-NICK.

Schrift (Lettern, Typen), metallene Buchstaben, welche zum Drucken eines Buches gebraucht werden. Die Schrift besteht aus vierseitigen, etwa 1 Zoll langen Stiften, auf denen oben der Buchstabe erhaben, aber links, gegossen ist. Die untere Seite des Stifts heißt der Fuß, der Unterschied zwischen Fuß und der obern Seite die Höhe. Die Entfernung von der untern Seite des Buchstabens bis zu dessen oberer (Stärke) und von einer Seite zur andern (Breite)

A B C D E F G H J K L M N O P Q R S T U V W X Y Z Ä Ö Ü

abcdefghijklmnopqrstuvwxyz

ch d ll s s i i s s t s s ä ö ü

\$ 1234567890 £

EIGHTEEN POINT GERMAN, No. 90.

1-NICK.

Schrift (Lettern, Typen), metallene Buchstaben, welche zum Drucken eines Buches gebraucht werden. Die Schrift besteht aus vierseitigen, etwa 1 Zoll langen Stiften, auf denen oben der Buchstabe erhaben, aber links, gegossen ist. Die untere Seite des Stifts heißt der Fuß, der Unterschied zwischen Fuß und der obern Seite die Höhe. Die Entfernung von der untern

A B C D E F G H J K L M N O P Q R S T U V W X Y Z

abcdefghijklmnopqrstuvwxyz

ch d ll s s i i s s t s s ä ö ü Ä Ö Ü

\$ 1234567890 £

V. B. MUNSON, SUCCESSOR TO
GEO. BRUCE'S SON & CO., 13 CHAMBERS STREET, NEW YORK.

TWENTY POINT GERMAN, No. 90.

Gleich nach der Erfindung der Buchdruckerkunst zeichneten sich die Deutschen als Schriftgießer aus; Pannartz und Schweynheim in Rom erfanden um 1470 die Antiqua, der Italiener Aldus Manutius in Venedig die Cursiv; später ging das Schriftgießen besonders nach Holland über, und die holländischen Antiquaschriften waren im 17. und 18. Jahrhundert berühmt.

A B C D E F G H I J K L M N O P Q R S T U V

a b c d e f g h i j k l m n o p q r s t u v w x y z

ch ð ll s fi ff st ß ß 1 2 3 4 5 6 7 8 9 0

TWENTY-FOUR POINT GERMAN, No. 90.

Gutenberg wurde um's Jahr 1399 in der Stadt Mainz geboren

THIRTY-TWO POINT GERMAN, No. 90.

Jedenfalls kehrte Gutenberg nach Mainz zurück

STYLE 90.

10 a 5 A—23 lb.

48-POINT GERMAN, No. 90.

\$8.75.

Staats Zeitung

5 a 3 A—30 lb.

72-POINT GERMAN, No. 90.

\$11.30.

Wie gehts 2

5 a 3 A—42 lb. 8 oz.

96-POINT GERMAN, No. 90.

\$16.15.

Schlösser

5 a 3 A—75 lb.

144-POINT GERMAN, No. 90.

\$28.50.

Söhnte

V. B. MUNSON, SUCCESSOR TO
GEO. BRUCE'S SON & CO., 13 CHAMBERS STREET, NEW YORK.

STYLE 91.

SIX POINT GERMAN, No. 91.

3-NICK.

Schriftsteller, ist der Verfasser eines zum öffentlichen Gebrauch bestimmten Schriftwerkes. Schriftstellerei setzt daher überall die einigermaßen allgemeine Verbreitung der Schreibekunst voraus; mit der Leichtigkeit und Sicherheit der Ver- vielfältigung und Verbreitung des Geschriebenen wird ihre Thätigkeit und Wirksamkeit gesteigert. Ursprünglich schrieben nur die für den öffentlichen Gebrauch, welche etwas der Aufbewahrung Würdiges zu schreiben hatten; die ältesten Schriftdenkmale der Völker enthalten überall Aufzeichnungen merkwürdiger historischer Ereignisse, religiöser Satzungen, epischer Gesänge, welche vorher durch mündliche Tradition fortgepflanzt im Munde des Volkes gelebt hatten und durch die Schrift fixirt wurden. Dazu kommen aber frühzeitig absichtlich gesammelte Erzählungen wichtiger Ereignisse, Aufzeich- nungen merkwürdiger Beobachtungen aus dem Gebiete der Natur, Erzeugnisse der Dichtkunst und des Nachdenkens. Geschichte, Poesie, Philosophie und Naturkunde waren daher im Alterthum, namentlich bei den Griechen und den Römern, die Hauptgebiete der schriftstellerischen Production. Es ist natürlich, daß zu jeder Zeit und bei jedem Volke zunächst die geistig hervorragendsten Individuen als Schriftsteller austraten; daher, so lange die geistige Cultur nicht allgemein verbreitet ist, wie in dem früheren Alterthum und dann wieder im Mittelalter, die Schriftstellerei vorzugsweise in den Händen der Priester und Geistlichen war; ebenso natürlich ist aber auch, daß die Veranlassungen zu einer schriftstellerischen Thätigkeit, so wie die Wirksamkeit ihrer Producte nicht bloß mit der allgemeineren Verbreitung der geistigen Cultur,

ABCDEFGHIJKLMN OPQRSTUVWXYZ ÄÜ

ch d l f i f f f t h g ä ö ü

abcdefghijklmnopqrstuvwxyz

§ 1234567890 £

SEVEN POINT GERMAN, No. 91.

2-NICK.

Schriftsteller, ist der Verfasser eines zum öffentlichen Gebrauch bestimmten Schriftwerkes. Schriftstellerei setzt daher überall die einigermaßen allgemeine Verbreitung der Schreibekunst voraus; mit der Leichtigkeit und Sicherheit der Ver- vielfältigung und Verbreitung des Geschriebenen wird ihre Thätigkeit und Wirksamkeit gesteigert. Ursprünglich schrieben nur die für den öffentlichen Gebrauch, welche etwas der Aufbewahrung Würdiges zu schreiben hatten; die ältesten Schriftdenkmale der Völker enthalten überall Aufzeichnungen merkwürdiger historischer Ereignisse, religiöser Satzungen, epischer Gesänge, welche vorher durch mündliche Tradition fortgepflanzt im Munde des Volkes gelebt hatten und durch die Schrift fixirt wurden. Dazu kommen aber frühzeitig absichtlich gesammelte Erzählungen wichtiger Ereignisse, Aufzeichnungen merkwürdiger Beobachtungen aus dem Gebiete der Natur, Erzeugnisse der Dichtkunst und des Nachdenkens. Geschichte, Poesie, Philosophie und Naturkunde waren daher im Alterthum, namentlich bei den Griechen und den Römern, die Hauptgebiete der schriftstellerischen Production. Es ist natürlich, daß zu jeder Zeit und bei jedem Volke zunächst die geistig hervorragendsten Individuen als Schriftsteller austraten; daher, so lange die geistige Cultur

ABCDEFGHIJKLMN OPQRSTUVWXYZ ÄÜ

ch d l f i f f f t h g ä ö ü

abcdefghijklmnopqrstuvwxyz

§ 1234567890 £

EIGHT POINT GERMAN, No. 91.

3-NICK.

Schriftsteller, ist der Verfasser eines zum öffentlichen Gebrauch bestimmten Schriftwerkes. Schriftstellerei setzt daher überall die einigermaßen allgemeine Verbreitung der Schreibekunst voraus; mit der Leichtigkeit und Sicherheit der Ver- vielfältigung und Verbreitung des Geschriebe- nen wird ihre Thätigkeit und Wirksamkeit gesteigert. Ursprünglich schrieben nur die für den öffentlichen Gebrauch, welche etwas der Aufbewahrung Würdiges zu schreiben hatten; die ältesten Schriftdenkmale der Völker enthalten überall Aufzeichnungen merkwürdiger historischer Ereignisse, religiöser Satzungen, epischer Gesänge, welche vorher durch mündliche Tradition fortgepflanzt im Munde des Volkes gelebt hatten und durch die Schrift fixirt wurden. Dazu kommen aber frühzeitig absichtlich gesammelte Erzählungen wichtiger Ereignisse, Aufzeichnungen merkwürdiger Beobachtungen aus dem Gebiete der Natur, Erzeugnisse der Dichtkunst und des Nachdenkens. Geschichte, Poesie, Philosophie und Naturkunde waren daher im Alterthum,

ABCDEFGHIJKLMN OPQRSTUVWXYZ ÄÜ

ch d l f i f f f t h g ä ö ü

abcdefghijklmnopqrstuvwxyz

§ 1234567890 £

V. B. MUNSON, SUCCESSOR TO
GEO. BRUCE'S SON & CO., 13 CHAMBERS STREET, NEW YORK.

STYLE 91.

NINE POINT GERMAN, No. 91.

Schriftsteller, ist der Verfasser eines zum öffentlichen Gebrauch bestimmten Schriftwerkes. Schriftstellerei setzt daher überall die einigermaßen allgemeine Verbreitung der Schreibekunst voraus; mit der Leichtigkeit und Sicherheit der Vervielfältigung und Verbreitung des Geschriebenen wird ihre Thätigkeit und Wirksamkeit gesteigert. Ursprünglich schrieben nur die für den öffentlichen Gebrauch, welche etwas der Aufbewahrung Würdiges zu schreiben hatten; die ältesten Schriftdenkmale der Völker enthalten überall Aufzeichnungen merkwürdiger historischer Ereignisse, religiöser Satzungen, epischer Gesänge, welche vorher durch mündliche Tradition fortgepflanzt im Munde des Volkes gelebt hatten und durch die Schrift fixirt wurden. Dazu kommen aber frühzeitig absichtlich gesammelte Erzählungen wichtiger Ereignisse, Aufzeichnungen merkwürdiger Beobachtungen aus dem Gebiete der Natur, Erzeugnisse der Dichtkunst und des Nachdenkens. Geschichte, Poesie, Philosophie und Naturkunde waren daher im Alterthum, namentlich bei den Griechen und den Römern, die Hauptgebiete der schriftstellerischen Production. Es ist natürlich, daß zu jeder Zeit und bei jedem Volke zunächst die geistig hervorragenden Individuen als Schriftsteller auftraten; daher, so lange die geistige Cultur nicht allgemein verbreitet ist, wie in dem früheren Alterthum und dann wieder im Mittelalter, die Schriftstellerei vorzugsweise in den Händen der Priester und Geistlichen war; ebenso natürlich ist aber auch, daß die Veranlassungen zu einer schriftstellerischen Thätigkeit, so wie die Wirksamkeit ihrer Producte nicht bloß mit der allgemeineren Verbreitung der

A B C D E F G H I J K L M N O P Q R S T U V W X Y Z Ä Ö Ü

ch ð ll f fi ff st ß þ ä ö ü

abcdefghijklmnopqrstuvwxyz

\$1234567890£

TEN POINT GERMAN, No. 91.

Schriftsteller, ist der Verfasser eines zum öffentlichen Gebrauch bestimmten Schriftwerkes. Schriftstellerei setzt daher überall die einigermaßen allgemeine Verbreitung der Schreibekunst voraus; mit der Leichtigkeit und Sicherheit der Vervielfältigung und Verbreitung des Geschriebenen wird ihre Thätigkeit und Wirksamkeit gesteigert. Ursprünglich schrieben nur die für den öffentlichen Gebrauch, welche etwas der Aufbewahrung Würdiges zu schreiben hatten; die ältesten Schriftdenkmale der Völker enthalten überall Aufzeichnungen merkwürdiger historischer Ereignisse, religiöser Satzungen, epischer Gesänge, welche vorher durch mündliche Tradition fortgepflanzt im Munde des Volkes gelebt hatten und durch die Schrift fixirt wurden. Dazu kommen aber frühzeitig absichtlich gesammelte Erzählungen wichtiger Ereignisse, Aufzeichnungen merkwürdiger Beobachtungen aus dem Gebiete der Natur, Erzeugnisse der Dichtkunst und des Nachdenkens. Geschichte, Poesie, Philosophie und Naturkunde waren daher im Alterthum, namentlich bei den Griechen und den Römern, die Hauptgebiete der schriftstellerischen Production. Es ist natürlich, daß zu jeder Zeit und bei jedem Volke

A B C D E F G H I J K L M N O P Q R S T U V W X Y Z Ä Ö Ü

ch ð ll f fi ff st ß þ ä ö ü

abcdefghijklmnopqrstuvwxyz

\$1234567890£

V. B. MUNSON, SUCCESSOR TO
GEO. BRUCE'S SON & CO., 13 CHAMBERS STREET, NEW YORK.

STYLE 91.

ELEVEN POINT GERMAN, No. 91.

Schriftsteller, ist der Verfasser eines zum öffentlichen Gebrauch bestimmten Schriftwerkes. Schriftstellerei setzt daher überall die einigermaßen allgemeine Verbreitung der Schreibekunst voraus; mit der Leichtigkeit und Sicherheit derervielfältigung und Verbreitung des Geschriebenen wird ihre Thätigkeit und Wirksamkeit gesteigert. Ursprünglich schrieben nur die für den öffentlichen Gebrauch, welche etwas der Aufbewahrung Würdiges zu schreiben hatten; die ältesten Schriftdenkmale der Völker enthalten überall Aufzeichnungen merkwürdiger historischer Ereignisse, religiöser Sagen, epischer Gesänge, welche vorher durch mündliche Tradition fortgepflanzt im Munde des Volkes gelebt hatten und durch die Schrift fixirt wurden. Dazu kommen aber frühzeitig absichtlich gesammelte Erzählungen wichtiger Ereignisse, Aufzeichnungen merkwürdiger Beobachtungen aus dem Gebiete der Natur, Erzeugnisse der Dichtkunst und des

A B C D E F G H I J K L M N O P Q R S T U V W X Y Z Ä Ö Ü

ch d ll f f f f t ß k ä ö ü abcdefghijklmnopqrstuvwxyz \$1234567890£

TWELVE POINT GERMAN, No. 91.

Schriftsteller, ist der Verfasser eines zum öffentlichen Gebrauch bestimmten Schriftwerkes. Schriftstellerei setzt daher überall die einigermaßen allgemeine Verbreitung der Schreibekunst voraus; mit der Leichtigkeit und Sicherheit derervielfältigung und Verbreitung des Geschriebenen wird ihre Thätigkeit und Wirksamkeit gesteigert. Ursprünglich schrieben nur die für den öffentlichen Gebrauch, welche etwas der Aufbewahrung Würdiges zu schreiben hatten; die ältesten Schriftdenkmale der Völker enthalten überall Aufzeichnungen merkwürdiger historischer Ereignisse, religiöser Sagen, epischer Gesänge, welche vorher durch mündliche Tradition fortgepflanzt im Munde des Volkes gelebt hatten und durch die Schrift fixirt wurden. Dazu kommen aber frühzeitig absichtlich

A B C D E F G H I J K L M N O P Q R S T U V W X Y Z Ä Ö Ü

abcdefghijklmnopqrstuvwxyz

ch d ll f f f f t ß k ä ö ü \$ 1234567890 £

STYLE 490.

60 a 20 A—3 lb.

6-POINT GERMAN TITLE, No. 490.

\$3.50.

Am Schlusse des fünfzehnten Jahrhunderts befanden sich zweiundzwanzig Buchdruckereien in Köln. Unter ihnen befand sich diejenige des Arnold Ter Hoorne, der trotz seiner gelegentlichen schlechten Druckarbeit erwähnt zu werden verdient als der erste in Deutschland, welcher

A B C D E F G H I J K L M N O P Q R S T U V W X Y Z

ch d ll f fi ff st s s abcdefghijklmnopqrstuvwxyz; 1234567890

60 a 20 A—3 lb. 8 oz.

7-POINT GERMAN TITLE, No. 490.

\$3.50.

Die Buchdruckerkunst wurde im Jahre 1468 in Augsburg eingeführt durch Günther Janier aus Neutlingen, der vermuthlich in Strasburg gelernt hatte. Er war der erste Buchdrucker in Deutschland, welcher ein Buch mit Antiquaschrift druckte. Seine Bücher waren mit vielen

A B C D E F G H I J K L M N O P Q R S T U V W X Y Z

ch d ll f fi ff st s s abcdefghijklmnopqrstuvwxyz; 1234567890

60 a 20 A—5 lb. 8 oz.

8-POINT GERMAN TITLE, No. 490.

\$4.95.

Es ist wahrscheinlich, daß der Drucker der vier merkwürdigen Ausgaben des „Speculum“ sich in Utrecht befand, ehe Ketelaer im Jahre 1743

A B C D E F G H I J K L M N O P Q R S T U V W X Y Z

ch d ll f fi ff st s s abcdefghijklmnopqrstuvwxyz; 1234567890

30 a 10 A—3 lb.

9-POINT GERMAN TITLE, No. 490.

\$2.40.

Ulrich Zell, der erste Buchdrucker in Köln, druckte nie ein Buch in deutscher Schrift. Seine sämtlichen Bücher waren mit gothischer von

A B C D E F G H I J K L M N O P Q R S T U V W X Y Z

ch d ll f fi ff st s s abcdefghijklmnopqrstuvwxyz; 1234567890

30 a 10 A—4 lb.

10-POINT GERMAN TITLE, No. 490.

\$2.95.

In Strasburg fanden die Buchdrucker mehr Ermuthigung als in Mainz, indem dort schon vor 1500 sechszehn Buch-

A B C D E F G H I J K L M N O P Q R S T U V W X Y Z

ch d ll f fi ff st s s abcdefghijklmnopqrstuvwxyz; 1234567890

30 a 10 A—4 lb. 8 oz.

11-POINT GERMAN TITLE, No. 490.

\$3.15.

Gutenberg hat die ersten von ihm gedruckten Sachen weder mit seinem Namen noch mit einer Zeitangabe versehen.

A B C D E F G H I J K L M N O P Q R S T U V W X Y Z

ch d ll f fi ff st s s abcdefghijklmnopqrstuvwxyz; 1234567890

30 a 10 A—5 B. 14 oz.

12-POINT GERMAN TITLE, No. 490.

\$3.85.

Ueber Gutenberg's Thätigkeit in den nächstfolgenden Jahren herrscht tiefes Dunkel 1234

30 a 10 A—7 B. 4 oz.

14-POINT GERMAN TITLE, No. 490.

\$4.50.

Die erste Druckerpresse in Schottland wurde in Edinburg aufgestellt 1234

25 a 8 A—9 B. 2 oz.

18-POINT GERMAN TITLE, No. 490.

\$5.50.

Gutenberg vollendete das Katholikon des Johannes im Jahre 1460

25 a 8 A—13 B. 2 oz.

22-POINT GERMAN TITLE, No. 490.

\$7.35.

Die chinesische Schrift enthält 84,000 Lettern 1234

20 a 7 A—16 B. 10 oz.

28-POINT GERMAN TITLE, No. 490.

\$9.30.

Die ersten Typen glichen den Handschriften 12

15 a 6 A—18 B.

36-POINT GERMAN TITLE, No. 490.

\$10.10.

**Gutenberg, Schöffer
u. Faust 2369**

STYLE 491.

60 a 20 A—2 lb. 6 oz.

6-POINT GERMAN CONDENSED, No. 491.

\$2.75.

Den Griechen und Römern war die Buchdruckerkunst nicht bekannt, doch verstanden sie die Kunst, durch die offenen Stellen anschnittener Bleche durchzumalen, wie dies auf Waarenballen und dergleichen noch jetzt geschieht. Die Erfindung, Figuren, Bilder und Schrift mittelst gestochener Metallplatten oder in Holz geschnittener Formen zu vervielfältigen, fällt erst in das 14. Jahrhundert und gab ohne Zweifel die erste Anregung zu der Entdeckung, Schriftformen aus beweglichen Typen zusammenzusetzen, so daß diese nach dem Abdruck aus einander genommen und zur Zusammensetzung neuer Schriftformen benutzt werden konnten. Die Entwickelung der Buchdruckerkunst scheint auf die folgende Weise vor sich gegangen zu sein: 1) Die Anwendung erhabener geschnittener Formen zum Drucken von Seide und

ABCDEFGHIJKL MNOPQRSTUVWXYZ

ch d ll f ff ft h k abcdefghijklmnopqrstuvwxyz 1234567890

60 a 20 A—4 lb.

8-POINT GERMAN CONDENSED, No. 491.

\$3.60.

Das Jahr 1440 ist keineswegs das richtige Erfindungsjahr der Buchdruckerkunst, obgleich man herkömmlich dieses Jahr als das Erfindungsjahr annimmt auch 1840 allgemein wieder das Jubiläum der Erfindung gefeiert hat, wie es 1540, 1640 und 1740 schon begangen wurde. Im Jahre 1455 trennte sich Gutenberg von seinen beiden Gesellschaftern, und diese setzten nun das ursprüngliche Geschäft fort, vollendeten die 42zeilige Bibel in 2 Foliobänden (wahrscheinlich 1456) und begannen darauf Bücher mit kleineren Lettern zu drucken: zugleich legte Gutenberg eine neue Druckerei an. Das erste bekannte Buch mit Angabe des Druckjahrs war das

ABCDEFGHIJKL MNOPQRSTUVWXYZ

ch d ll f ff ft h k abcdefghijklmnopqrstuvwxyz 1234567890

30 a 10 A—3 lb.

10-POINT GERMAN CONDENSED, No. 491.

\$2.20.

In der ersten Zeit des Buchdruckes waren die Drucker zugleich Schriftgießer, Buchhändler und nicht selten auch Gelehrte. Erst allmählig bildeten sich die Buchdruckerei und die Schriftgießerei als selbstständige Gewerbe aus, dagegen findet sich Verleger und Drucker noch jetzt häufig in einer Person vereinigt. Das Buchdruckergerwerbe trat von vorn herein als eine Kunst auf und wurde als solche von den gebildeten und höheren Ständen betrieben, auch wetteiferten die Buchdrucker der frühesten Zeit, ihren Zeugnissen ein zierliches und schönes Aussehen

ABCDEFGHIJKL MNOPQRSTUVWXYZ

ch d ll f ff ft h k abcdefghijklmnopqrstuvwxyz 1234567890

30 a 10 A—4 lb. 2 oz.

12-POINT GERMAN CONDENSED, No. 491.

\$2.70.

Ein Jahrzehnt später war es wieder ein Fremder, der den Gedanken eines Gutenbergdenkmals anregte. Professor Gio. Batt. Micheletti, ein Neapolitaner, schrieb: „Nicht allein Deutschland, nicht allein Europa, sondern die ganze Welt muß zusammenwirken, Gutenberg ein Denkmal der Dankbarkeit zu errichten.“ Bis auf den heutigen Tag aber existirt

ABCDEFGHIJKL MNOPQRSTUVWXYZ

ch d ll f ff ft h k abcdefghijklmnopqrstuvwxyz 1234567890

Bodenheimer sagt mit Recht: „Man würde in Mainz den Eintrag in dem Dominikanerbuche beachtet haben, wenn man überhaupt in Mainz, um Gutenberg und seine Kunst sich bekümmert hätte; das Volk so wenig als die Mönche, bei denen er lag, wußten bei Beginn des siebenzehnten Jahrhunderts, zu welcher Zeit das Grabmal schwerlich noch zu sehen war, noch irgend etwas von ihm, und auch im achthebnten Jahrhundert haben die Mainzer Gelehrten, wie selbst ein

ABCDEFGHIJKL MNOPQRSTUVWXYZ
\$ 1234567890

Ueber Gutenberg's Thätigkeit in den nächstfolgenden Jahren herrscht tiefes Dunkel. Jedenfalls kehrte Gutenberg nach Mainz zurück; hier vereinigte er sich zu Ende August 1450 mit Johann Faust zur Uebung der Buchdruckerkunst in dem Hause „Zum Jungen“.

ABCDEFGHIJKL MNOPQRSTUVWXYZ
\$ 1234567890

Garten der Gesundheit, ist der Titel des ersten Buches, welches Schöffer mit deutschen Lettern druckte 123

20 a 7 A—12 lb. 8 oz. 28-POINT GERMAN CONDENSED, No. 491.

\$7.00.

Krent euch des Lebens weil noch
das Lämpchen glüth 123

15 a 6 A—14 lb. 14 oz. 36-POINT GERMAN CONDENSED, No. 491.

\$8.35.

Der Hoorn wandte zuerst die
arabischen Ziffern an 12

10 a 5 A—14 lb. 14 oz. 40-POINT GERMAN CONDENSED, No. 491.

\$7.70.

Gutenberg trennte sich
von Just in 1455

10 a 5 A—21 lb. 8 oz. 48-POINT GERMAN CONDENSED, No. 491.

\$11.60.

Schöffer starb im
Jahre 1502

STYLE 590.

30 a 10 A—4 B.

11-POINT GERMAN OPEN, No. 590.

\$4.80.

**Die Stadt Mainz, das Moguntiacum, hat den doppelten
Ruhm, zugleich die Geburtsstätte des Erfinders
und der Erfindung der Buchdruckerkunst zu sein 123**

30 a 10 A—7 B. 12 oz.

16-POINT GERMAN OPEN, No. 590.

\$8.20.

**Gutenberg hat die ersten von ihm gedruckten
Sachen weder mit seinem Namen
noch mit einer Zeitangabe versehen 123**

20 a 7 A—9 B. 8 oz.

24-POINT GERMAN OPEN, No. 590.

\$8.55.

**In 1462 beendigten Just und
Schöffer den kostspieligen
Druck einer lateinischen Bibel**

15 a 6 A—14 B.

32-POINT GERMAN OPEN, No. 590.

\$12.05.

**Die erste Druckerpresse in
Schottland wurde in
Edinburg aufgestellt 12**

V. B. MUNSON, SUCCESSOR TO
GEO. BRUCE'S SON & CO., 13 CHAMBERS STREET, NEW YORK.

STYLE 101.

20 A—2 lb. 2 oz.

9-POINT, No. 101.

\$1.70.

**BUT THERE IS A CERTAIN HISTORICAL
SIGNIFICANCE IN THE EVENT 123**

20 A—2 lb. 12 oz.

10-POINT, No. 101.

\$2.05.

**PRESENTED AN UNUSUALLY LIVELY
AND PROSPEROUS ASPECT 134**

20 A—3 lb. 4 oz.

11-POINT, No. 101.

\$2.30.

**SUFFERED SOMEWHAT OF LATE
OWING TO THE LACK 123**

15 A—2 lb. 14 oz.

12-POINT, No. 101.

\$1.90.

**LOYAL SUPPORT THE COMPANY
NATURALLY EXPECTED 123**

15 A—3 lb. 12 oz.

14-POINT, No. 101.

\$2.35.

**THE PRINCIPAL INDUSTRY
OF THE VILLAGE 123**

15 A—4 lb. 8 oz.

16-POINT, No. 101.

\$2.70.

**VIRTUALLY A MONOPOLY
OF THE TRADE 123**

12 A—4 lb. 10 oz.

18-POINT, No. 101.

\$2.80.

**TOOK THE INITIATIVE
IN THE WORK 123**

V. B. MUNSON, SUCCESSOR TO
GEO. BRUCE'S SON & CO., 13 CHAMBERS STREET, NEW YORK.

STYLE 101.

12 A—6 B. 2 oz.

20-POINT, No. 101.

\$3.70.

**ABSURDITY OF SUCH
A PROPOSAL 123**

12 A—8 B.

22-POINT, No. 101.

\$4.50.

**MOST APPARENT
AT START 12**

10 A—8 B.

24-POINT, No. 101.

\$4.50.

**ANY NECESSITY
ARISING 12**

10 A—9 B. 8 oz.

28-POINT, No. 101.

\$5.35.

**REMARKABLE
DISPLAY 12**

8 A—9 B. 10 oz.

32-POINT, No. 101.

\$5.40.

**TYPOGRAPH
UNION 12**

V. B. MUNSON, SUCCESSOR TO
GEO. BRUCE'S SON & CO., 13 CHAMBERS STREET, NEW YORK.

STYLE 102.

20 A—1 lb. 10 oz.

9-POINT, No. 102.

\$1.30.

**THUS READY FOR THE WAY OF LIFE OR DEATH,
I WAIT THE SHARPEST BLOW 1234**

20 A—2 lb.

10-POINT, No. 102.

\$1.50.

**BE QUIET THEN, AS MEN SHOULD BE, TILL HE
HATH PAST NECESSITY 1234**

20 A—2 lb. 8 oz.

11-POINT, No. 102.

\$1.75.

**WE SHALL HAVE HIM HERE TO-MORROW,
WITH HIS BEST RUFF ON 1234**

15 A—2 lb. 4 oz.

12-POINT, No. 102.

\$1.50.

**WHAT HE WILL DO GRACIOUSLY WILL
I THANKFULLY RECEIVE 1234**

15 A—3 lb. 10 oz.

14-POINT, No. 102.

\$2.25.

**THE FITTER THEN THE GODS
SHOULD HAVE HER 1234**

15 A—3 lb. 10 oz.

16-POINT, No. 102.

\$2.20.

**SHE IS ALL HAPPY AS THE
FAIREST OF ALL 1234**

V. B. MUNSON, SUCCESSOR TO
GEO. BRUCE'S SON & CO., 13 CHAMBERS STREET, NEW YORK.

STYLE 102.

12 A—4 lb.

18-POINT, No. 102.

\$2.40.

**HER REASON TO HERSELF
IS ONLY KNOWN 1234**

12 A—4 lb. 12 oz.

20-POINT, No. 102.

\$2.85.

**HE HATH FOUND THE
MEANING OF IT 12**

12 A—5 lb. 12 oz.

22-POINT, No. 102.

\$3.25.

**AS YON GRIM LOOK
DOTH TESTIFY 12**

10 A—6 lb. 6 oz.

24-POINT, No. 102.

\$3.60.

**WHOM I PRETEND
TO DO HONOR 12**

10 A—8 lb. 2 oz.

28-POINT, No. 102.

\$4.55.

**TO MAKE ME DO
HIS WILL 12**

V. B. MUNSON, SUCCESSOR TO
GEO. BRUCE'S SON & CO., 13 CHAMBERS STREET, NEW YORK.

STYLE 103.

20 A-1 lb. 8 oz.

9-POINT, No. 103.

\$1.20.

NOW WOULD I GIVE A THOUSAND FURLONGS OF SEA
FOR A SINGLE ACRE OF BARREN GROUND 1234

20 A-2 lb.

10-POINT, No. 103.

\$1.50.

THE WILLS ABOVE US BE DONE! BUT I WOULD
FAIN DIE A DRY DEATH, O FERDINAND 1234

20 A-2 lb. 8 oz.

11-POINT, No. 103.

\$1.75.

HERE'S NEITHER BRUSH NOR SHRUB, TO
BEAR OFF ANY WIND AT ALL 1234

15 A-2 lb. 2 oz.

12-POINT, No. 103.

\$1.40.

ANOTHER STORM IS BREWING! WOW! I
HEAR IT SING I' THE WIND 1234

15 A-2 lb. 12 oz.

14-POINT, No. 103.

\$1.70.

YON BLACK CLOUD LOOKS LIKE
HE'D SHED HIS LIQUOR 1234

15 A-3 lb. 6 oz.

16-POINT, No. 103.

\$2.05.

WHAT HAVE YE HERE? A MAN
FISH? DEAD OR ALIVE? 1234

12 A-3 lb. 6 oz.

18-POINT, No. 103.

\$2.05.

HE SMELLS LIKE A FISH 1234

12 A-5 lb. 12 oz.

22-POINT, No. 103.

\$3.20.

A FISHY SMELL 1234

V. B. MUNSON, SUCCESSOR TO
GEO. BRUCE'S SON & CO., 13 CHAMBERS STREET, NEW YORK.

STYLES 104 and 107.

15 A—2 lb. 10 oz.

14-POINT, No. 104,

\$1.65.

**TEACH ME, DEAR CREATURE, HOW
TO THINK AND SPEAK 1234**

15 A—3 lb. 10 oz.

16-POINT, No. 104.

\$2.20.

**YOU WERE BEST TO CALL THEM
GENERALLY, MY LORD 1234**

20 A—2 lb. 10 oz.

11-POINT, No. 107.

\$1.85.

**IN SOOTH, I KNOW NOT WHY I AM SO
SAD; YOU SAY IT WEARIES 1234**

15 A—2 lb. 6 oz.

12-POINT, No. 107.

\$1.60.

**HAVE YOU HEARD ANY IMPUTATION
TO THE CONTRARY, SIR 1234**

15 A—3 lb.

14-POINT, No. 107.

\$1.90.

**AND THEN THERE IS THE PERIL
OF WATER AND WIND 1234**

15 A—3 lb. 10 oz.

16-POINT, No. 107.

\$2.20.

**FIFTEEN THOUSAND DUCATS
FOR THREE MONTHS 1234**

V. B. MUNSON, SUCCESSOR TO
GEO. BRUCE'S SON & CO., 13 CHAMBERS STREET, NEW YORK.

STYLE 105.

20 A—2 lb. 6 oz.

11-POINT, No. 105.

\$1.65.

HIS REASONS ARE TWO GRAINS OF WHEAT
HID IN TWO BUSHELS OF CHAFF 1234

15 A—2 lb. 4 oz.

12-POINT, No. 105.

\$1.50.

YOU SHALL SEEK ALL DAY ERE YOU
WILL FIND THEM, ANTONIO 3456

15 A—2 lb. 14 oz.

14-POINT, No. 105.

\$1.80.

WE HAD A QUARREL O'ER IT 1234

15 A—3 lb. 6 oz.

16-POINT, No. 105.

\$2.05.

AND SO WE TWO PARTED 1234

12 A—3 lb. 14 oz.

18-POINT, No. 105.

\$2.30.

AND FOR FOUR DAYS 1234

12 A—4 lb. 8 oz.

20-POINT, No. 105.

\$2.70.

I'LL BE WITH YOU 1234

12 A—5 lb. 4 oz.

22-POINT, No. 105.

\$2.95.

IF I CAN CATCH ON 12

10 A—5 lb. 14 oz.

24-POINT, No. 105.

\$3.30.

TO SOME QUOIN 12

10 A—7 lb. 8 oz.

28-POINT, No. 105.

\$4.20.

O MARGARET! 12

V. B. MUNSON, SUCCESSOR TO
GEO. BRUCE'S SON & CO., 13 CHAMBERS STREET, NEW YORK.

STYLE 106.

20 A—2 B.

10-POINT, No. 106.

\$1.50.

FAITH, WE MET, AND FOUND THE QUARREL
WAS UPON THE SEVENTH CAUSE 1234

15 A—2 B. 8 oz.

12-POINT, No. 106.

\$1.65.

IF ANY MAN DOUBT THAT LET'S
PUT HIM TO THE TEST 1234

15 A—3 B.

14-POINT, No. 106.

\$1.85.

I HAVE HAD FOUR QUARRELS
AND ONE GOOD SCRAP 1234

15 A—3 B. 12 oz.

16-POINT, No. 106.

\$2.25.

THAT IS QUANTUM SUF 12

12 A—4 B. 2 oz.

18-POINT, No. 106.

\$2.50.

HE IS SURELY SWIFT 12

12 A—4 B. 14 oz.

20-POINT, No. 106.

\$2.90.

HOW SAY YOU NOW 12

12 A—4 B. 14 oz.

22-POINT, No. 106.

\$2.70.

AN ANGRY TENOR 12

10 A—6 B.

24-POINT, No. 106.

\$3.35.

ACQUAINTANCE 12

V. B. MUNSON, SUCCESSOR TO
GEO. BRUCE'S SON & CO., 13 CHAMBERS STREET, NEW YORK.

STYLE 121.

20 A—1 lb. 2 oz.

9-POINT CONDENSED, No. 121.

\$0.90.

IN THE SUMMER NO ONE'S GLUMMER THAN THE PLUMBER, BUT WHEN THE
WEATHER'S COLDER HE WILL TAKE HIS TIME TO LAUGH; 1234

20 A—1 lb. 8 oz.

10-POINT CONDENSED, No. 121.

\$1.10.

IN WINTER'S BLEAK HE'LL TAKE A WEEK TO STOP A LEAK THAT
OUGHT TO TAKE AN HOUR AND A HALF 1234

15 A—1 lb. 10 oz.

12-POINT CONDENSED, No. 121.

\$1.10.

HATH BEEN TUTORED IN THE RUDIMENTS OF MANY
DESPERATE STUDIES BY HIS UNCLES 1234

12 A—2 lb. 2 oz.

16-POINT CONDENSED, No. 121.

\$1.30.

THEY SHALL BE MARRIED TO-MORROW 12

12 A—3 lb. 4 oz.

20-POINT CONDENSED, No. 121.

\$1.95.

AND I WILL BID THE DUKE COME 12

10 A—3 lb. 14 oz.

24-POINT CONDENSED, No. 121.

\$2.20.

START THE MUSIC, GEORGE 12

10 A—4 lb. 2 oz.

28-POINT CONDENSED, No. 121.

\$2.30.

ENCYCLOPÆDIA. BRITANNICA 12

8 A—5 lb. 2 oz.

36-POINT CONDENSED, No. 121.

\$2.90.

THE MAN WITH A HOE 12

V. B. MUNSON, SUCCESSOR TO
GEO. BRUCE'S SON & CO., 13 CHAMBERS STREET, NEW YORK.

STYLE 122.

20 A—1 lb. 10 oz.

10-POINT CONDENSED, No. 122.

\$1.20.

THEN HE'S A MOST NOTABLE COWARD, AN INFINITE AND
ENDLESS LIAR, AN HOURLY PROMISE-BREAKER 1234

15 A—1 lb. 12 oz.

12-POINT CONDENSED, No. 122.

\$1.15.

AND THE OWNER OF NOT ONE GOOD QUALITY
WORTHY YOUR LORDSHIP'S NOTICE 1234

15 A—2 lb. 10 oz.

16-POINT CONDENSED, No. 122.

\$1.60.

FOR THE LOVE OF LAUGHTER, HINDER
NOT THE HUMOR OF HIM 1234

12 A—3 lb. 4 oz.

18-POINT CONDENSED, No. 122.

\$1.95.

WHEREIN HAVE YOU PLAYED THE
KNAVE WITH FORTUNE 1234

12 A—3 lb. 10 oz.

20-POINT CONDENSED, No. 122.

\$2.20.

OF MOST CHASTE RENOWN 12

12 A—4 lb. 12 oz.

22-POINT CONDENSED, No. 122.

\$2.65.

WHERE'S YOUR MASTER 12

10 A—4 lb. 10 oz.

24-POINT CONDENSED, No. 122.

\$2.60.

ALL YET SEEMS WELL 12

V. B. MUNSON, SUCCESSOR TO
GEO. BRUCE'S SON & CO., 13 CHAMBERS STREET, NEW YORK.

STYLES 123 and 600.

10 A—6 lb. 4 oz.

28-POINT CONDENSED, No. 123.

\$3.50.

TWELFTH NIGHT 12

8 A—8 lb.

36-POINT CONDENSED, No. 123.

\$4.50.

WARKWORTH 2

15 A—1 lb. 12 oz.

16-POINT CONDENSED, No. 600.

\$1.85.

IF MUSIC BE THE FOOD OF LOVE, PLAY ON; GIVE ME EXCESS
OF IT; PLEASE REPEAT THAT STRAIN, LUBAR 1234

10 A—3 lb.

24-POINT CONDENSED, No. 600.

\$2.70.

ENOUGH; NO MORE; 'TIS NOT SO SWEET
NOW AS IT WAS BEFORE, SIR 1234

8 A—4 lb. 10 oz.

40-POINT CONDENSED, No. 600.

\$3.60.

SO FULL OF SHAPES IS FANCY 12

V. B. MUNSON, SUCCESSOR TO
GEO. BRUCE'S SON & CO., 13 CHAMBERS STREET, NEW YORK.

STYLE 124.

20 A—1 lb. 2 oz.

9-POINT CONDENSED, No. 124.

\$0.90.

MOST RADIANT, EXQUISITE AND UNMATCHABLE BEAUTY, I PRAY YOU TELL
ME IF THIS BE THE LADY OF THE HOUSE, FOR I NEVER SAW HER 1234

20 A—1 lb. 8 oz.

10-POINT CONDENSED, No. 124.

\$1.10.

MADAM, THERE IS AT THE GATE A YOUNG GENTLEMAN WITH RED
WHISKERS WHO IS DESIROUS OF SPEAKING WITH YOU 1234

15 A—2 lb. 12 oz.

16-POINT CONDENSED, No. 124.

\$1.65.

ADMIT HIM, SLAVE; BUT FIRST BRING
HITHER MY TRUSTED GATLING 1234

12 A—3 lb. 4 oz.

20-POINT CONDENSED, No. 124.

\$1.95.

FLORID WHISKERS, FOR A VERITY,
SUGGEST THIS PRECAUTION 1234

10 A—4 lb. 12 oz.

24-POINT CONDENSED, No. 124.

\$2.65.

THE AUGUST LADY OF THE
HOUSE; WHICH IS SHE 12

V. B. MUNSON, SUCCESSOR TO
GEO. BRUCE'S SON & CO., 13 CHAMBERS STREET, NEW YORK.

STYLE 125.

20 A—1 lb. 8 oz.

10-POINT CONDENSED, No. 125.

\$1.10.

SOME ARE BORN GREAT, SOME ACHIEVE GREATNESS, AND SOME
HAVE GREATNESS THRUST UPON THEM 12345

15 A—1 lb. 10 oz.

12-POINT CONDENSED, No. 125.

\$1.10.

BY EACH PARTICULAR STAR IN HEAVEN, AND BY
ALL THEIR INFLUENCES, YOU MAY 1234

15 A—2 lb. 10 oz.

16-POINT CONDENSED, No. 125.

\$1.60.

AS WELL FORBID THE SEA TO OBEY THE
MOON, OR THE SUN TO SHINE 1234

5 A—7 lb. 10 oz.

48-POINT CONDENSED, No. 125.

\$4.15.

DISTRIBUTE

5 A—12 lb. 8 oz.

60-POINT CONDENSED, No. 125.

\$6.50.

PICAYUNE

5 A—17 lb. 8 oz.

72 POINT CONDENSED, No. 125.

\$9.10.

WEEKLY

96-POINT OF THIS SERIES ON PAGE 114.

V. B. MUNSON, SUCCESSOR TO
GEO. BRUCE'S SON & CO., 13 CHAMBERS STREET, NEW YORK.

STYLE 126.

20 A—1 lb. 12 oz.

10-POINT CONDENSED, No. 126.

\$1.30.

THE SUN BEGINS TO GILD THE WESTERN SKY, AND NOW
IS THE HOUR SYLVIA SHOULD MEET ME 1234567890

15 A—1 lb. 12 oz.

12-POINT CONDENSED, No. 126.

\$1.15.

YONDER COMES SYLVIA: AND SYLVIA IS MINE.
GIVE BACK, ELSE EMBRACE THY DEATH 123

15 A—2 lb. 4 oz.

14-POINT CONDENSED, No. 126.

\$1.40.

COME NOT WITHIN THE MEASURE OF MY
WRATH: CALL NOT SYLVIA THINE 123

15 A—3 lb. 6 oz.

16-POINT CONDENSED, No. 126.

\$2.05.

IF ONCE AGAIN, MILAN SHALL NOT
BEHOLD THEE. HERE SHE IS 123

12 A—2 lb. 14 oz.

18-POINT CONDENSED, No. 126.

\$1.70.

TAKE POSSESSION OF HER WITH A
TOUCH; I DARE THEE TO 1234

12 A—3 lb. 10 oz.

20-POINT CONDENSED, No. 126.

\$2.20.

BUT BREATHE UPON MY LOVE
MY OWN TRUE SYLVIA 1234

V. B. MUNSON, SUCCESSOR TO
GEO. BRUCE'S SON & CO., 13 CHAMBERS STREET, NEW YORK.

STYLE 126.

12 A—4 lb. 8 oz.

22-POINT CONDENSED, No. 126.

\$2.55.

I CARE NOT FOR HER, SIR; I
CLAIM HER NOT, AND 123

10 A—4 lb. 6 oz.

24-POINT CONDENSED, No. 126.

\$2.45.

THEREFORE YOU MAY BE
HER REAL OWNER 123

10 A—5 lb. 12 oz.

28-POINT CONDENSED, No. 126.

\$3.25.

MORE BASE ART THOU
TO LEAVE HER 123

8 A—6 lb. 14 oz.

36-POINT CONDENSED, No. 126.

\$3.85.

ON ANY SUCH EASY
CONDITIONS 123

V. B. MUNSON, SUCCESSOR TO
GEO. BRUCE'S SON & CO., 13 CHAMBERS STREET, NEW YORK.

STYLE 140.

60 a 30 A—1 lb. 12 oz. 5-POINT TITLE ROMAN, No. 140. \$3.15.

SINCE WHAT I AM TO SAY MUST BE BUT THAT WHICH CONTRADICTS
My accentuation, and the testimony on my part no other but what comes from myself, it shall scarce
best me to say "Not guilty;" 1234

60 a 30 A—2 lb. 5½-POINT TITLE ROMAN, No. 140. \$2.90.

MINE INTEGRITY, BEING COUNTED FALSEHOOD, SHALL,
As I express it, be so received. But thus, if powers divine behold our human actions, as I
most firmly believe they do, 1234

60 a 30 A—2 lb. 12 oz. 6-POINT TITLE ROMAN, No. 140. \$3.20.

I DOUBT NOT THEN BUT INNOCENCE SHALL MAKE
False accusation blush, and tyranny tremble at patience. You, my lord, best
know (who least will seem to do so) 1234

60 a 30 A—3 lb. 12 oz. 7-POINT TITLE ROMAN, No. 140. \$3.75.

MY PAST LIFE HAS BEEN AS CONTINENT,
As chaste, as true, as I am now unhappy, which is more than
history can pattern 1234

60 a 30 A—4 lb. 8 oz. 8-POINT TITLE ROMAN, No. 140. \$4.05.

THOUGH DEVIS'D, AND PLAY'D, TO TAKE
Spectators; for behold me, a fellow of the royal bed, a great
daughter, the mother to a 1234

40 a 20 A—3 lb. 4 oz. 9-POINT TITLE ROMAN, No. 140. \$2.60.

HOPEFUL PRINCE, HERE STANDING,
To prate and talk for life and honor before who please to
come and hear. For life, 1234

40 a 20 A—4 lb. 8 oz. 10-POINT TITLE ROMAN, No. 140. \$3.35.

I PRIZE IT, AS I WEIGH GRIEF,
Which I spare: for honor, 'tis a derivative from me
to mine, for which only I stand. 1234

V. B. MUNSON, SUCCESSOR TO
GEO. BRUCE'S SON & CO., 13 CHAMBERS STREET, NEW YORK.

STYLES 140 and 125.

40 a 20 A—4 lb. 12 oz.

11-POINT TITLE ROMAN, No. 140.

\$3.35.

WHERE'S BOHEMIA? SPEAK.

**Here in your city; I just now came from him; he's
o'ermuch in his cups, my lord 123**

30 a 15 A—5 lb. 2 oz.

12-POINT TITLE ROMAN, No. 140.

\$3.40.

THEN YOU ARE MARRIED?

**We are not, sir; nor are we likely to be
for several moons 123**

25 a 12 A—8 lb. 6 oz.

18-POINT TITLE ROMAN, No. 140.

\$5.00.

I RESCUED HER

**Her Highness is in safety, fear
you not, my lord 123**

4 A—26 lb.

96-POINT CONDENSED, No. 125.

\$13.00.

NOTES

V. B. MUNSON, SUCCESSOR TO
GEO. BRUCE'S SON & CO., 13 CHAMBERS STREET, NEW YORK.

STYLE 141.

60 a 30 A—2 lb. 12 oz. 6-POINT TITLE ITALIC, No. 141. \$3.20.

HEAVEN DEFEND MY SOUL FROM SUCH FOUL SIN!

*Shall I seem crest-fallen in my father's sight? Or with pale, shrieking beggar
fear impeach my height before this outdar'd dastard? 1234*

60 a 30 A—4 lb. 10 oz. 8-POINT TITLE ITALIC, No. 141. \$4.15.

MIKE, DEMAND OF YONDER CHAMPION

*The cause of his arrival here in arms; ask him his name;
swear him in the justice of his cause. 1234*

40 a 20 A—3 lb. 8 oz. 9-POINT TITLE ITALIC, No. 141. \$2.80.

IN GOD'S NAME AND THE KING'S, SAY

*Who thou art, and why thou com'st thus knightly clad in
arms; 'gainst what man com'st thou, 1234*

40 a 20 A—4 lb. 8 oz. 10-POINT TITLE ITALIC, No. 141. \$3.35.

AND WHAT'S THY QUARREL, SIR?

*Speak truly, on thy knighthood, and thine oath; so
defend thee heaven, and thy valor! 1234*

40 a 20 A—4 lb. 14 oz. 11-POINT TITLE ITALIC, No. 141. \$3.40.

MY NAME IS THOMAS MOWBRAY,

*Duke of Norfolk, who hither come engaged by my
oath both to defend my loyalty 1234*

30 a 15 A—5 lb. 4 oz. 12-POINT TITLE ITALIC, No. 141. \$3.50.

AND TRUTH TO GOD, TO

My king, and to my succeeding issue 123

25 a 12 A—8 lb. 14 oz. 18-POINT TITLE ITALIC, No. 141. \$5.35.

KING RICHARD II.

And craves to kiss thy hand 2

V. B. MUNSON, SUCCESSOR TO
GEO. BRUCE'S SON & CO., 13 CHAMBERS STREET, NEW YORK.

STYLE 143.

60 a 30 A—2 lb. 8 oz.

6-POINT TITLE ROMAN, No. 143.

\$2.90.

NOW IS THE WINTER OF OUR DISCONTENT MADE GLORIOUS

**Summer by this sun of York; and all the clouds that low'r'd upon our house in the
deep bosom of the ocean buried. Now are our brows bound with
victorious wreaths; Our bruised arms hung
up for monuments; 1234**

60 a 30 A—3 lb. 14 oz.

8-POINT TITLE ROMAN, No. 143.

\$3.50.

OUR STERN ALARUMS CHANG'D TO MERRY

**Meetings; Our dreadful marches to delightful measures. Grim-
visag'd war has smoothed his wrinkled front; And
now, instead of mounting 1234**

40 a 20 A—4 lb.

10-POINT TITLE ROMAN, No. 143.

\$2.95.

BARBED STEEDS, TO FRIGHT THE SOULS

**Of fearful adversaries, he capers nimbly in my lady's
chamber, to the lascivious pleasing of a
lute. But I, that am not 123**

30 a 15 A—5 lb.

12-POINT TITLE ROMAN, No. 143.

\$3.30.

**SHAPED FOR SPORTIVE TRICKS,
Nor made to court an amorous looking-
glass—I, that am rudely stamp'd,
and want love's majesty 12**

V. B. MUNSON, SUCCESSOR TO
GEO. BRUCE'S SON & CO., 13 CHAMBERS STREET, NEW YORK.

STYLE 144.

60 a 30 A—2 lb. 8 oz.

6-POINT TITLE ITALIC, No. 144.

\$2.90.

SET DOWN, SET DOWN, YOUR HONOURABLE LOAD,

*If honor may be shrouded in a hearse, whilst I awhile obsequiously lament the untimely
fall of virtuous Lancaster. Poor key-cold figure of a holy king!
Pale ashes of the house of Lancaster! 1234*

60 a 30 A—3 lb. 14 oz.

8-POINT TITLE ITALIC, No. 144.

\$3.50.

THOU BLOODLESS REMNANT OF THAT

*Royal blood! Be it lawful that I invoke thy ghost, to hear the
lamentations of poor Anne, wife to thy Edward,
to thy slaughter'd son, stabb'd 1234*

40 a 20 A—4 lb. 2 oz.

10-POINT TITLE ITALIC, No. 144.

\$3.05.

BY THE SELF-SAME HAND THAT

*Made these wounds! Lo, in these windows that let
forth thy life I pour the helpless balm
of my poor eyes: O, 1234*

30 a 15 A—5 lb.

12-POINT TITLE ITALIC, No. 144.

\$3.30.

CURSED BE THE HAND THAT

*Made these holes! Cursed the heart that
had the heart to do it! Cursed
the blood that let 1234*

V. B. MUNSON, SUCCESSOR TO
GEO. BRUCE'S SON & CO., 13 CHAMBERS STREET, NEW YORK.

STYLE 145.

60 a 30 A—2 lb. 10 oz.

6-POINT ENGRAVERS' ITALIC, No. 145.

\$3.05.

*NOT I, TILL I HAVE SHEATH'D MY RAPIER IN HIS BOSOM,
And withal, thrust those reproachful speeches down his throat that he hath breath'd
in my dishonour here 1234*

*Even as the sun with purple-colour'd face
Had ta'en his last leave of the weeping morn,
Rose-cheek'd Adonis kied him to the chase;
Hunting he loved, but love he laugh'd to scorn;
Sick-thoughted Venus makes amain unto him,
And like a bold-fac'd suitor 'gins to woo him.*

60 a 30 A—4 lb.

8-POINT ENGRAVERS' ITALIC, No. 145

\$3.60.

*ON, MY LORDS, THE BETTER FOOT BEFORE:
Straight will I bring you to the loathsome pit where I espied the
panther fast asleep. 1234*

*Vice is a monster of such hideous mien
That to be hated needs but to be seen;
Yet seen too oft, familiar with her face,
We first endure, then pity, then embrace.*

40 a 20 A—4 lb. 6 oz.

10-POINT ENGRAVERS' ITALIC, No. 145.

\$3.25.

*STAND BACK! ROOM! BEAR BACK!
If you have tears prepare to shed them now. You all do
know this mantle. I remember the first
time Cæsar put it on: 1234*

30 a 15 A—4 lb. 6 oz.

12-POINT ENGRAVERS' ITALIC, No. 145.

\$2.90.

*'T WAS ON A SUMMER EVENING,
In his tent. That day he overcame the Nervii.
Look! in this place ran Cassius'
dagger through 1234*

V. B. MUNSON, SUCCESSOR TO
GEO. BRUCE'S SON & CO., 13 CHAMBERS STREET, NEW YORK.

STYLES 146 AND 649.

60 a 30 A—4 lb. 2 oz.

8-POINT LAW ITALIC, No. 146.

\$3.70.

THE BLUE WATERS SKIRT ME RIGHT AND LEFT

*There is nothing but water before and only water behind. Above
me are sailing clouds, or the blue vault,
which we call, with childish license, heaven. The sails, white
and full, like helping friends, are
pushing me on, and night and day are distent with
the winds which come and go
none know whence, and none know whither 123567890*

40 a 20 A—4 lb. 8 oz.

10-POINT LAW ITALIC, No. 146.

\$3.35.

A LAND BIRD FLUTTERS ALOFT, WEARY

*With long flying, and lost in a world where are no
forests but the careening masts,
and no foliage but the drifts of white spray
It cleaves awhile to the smooth spars
till suddenly urged 12356*

30 a 15 A—4 lb. 8 oz.

12-POINT LAW ITALIC, No. 146.

\$2.95.

URGED BY HOMEWARD YEARNING

*It bears off in the face of the wind, and sinks
and rises over the angry waters
until its strength is gone, and the blue
waves squelch the poor flutterer 12345678*

25 a 12 A—4 lb. 12 oz.

18-POINT ITALIC HAIR-LINE, No. 649.

\$4.75.

ONE AFTERNOON LAST WEEK

*I climbed over the low wall that skirts the yard and
plucked a flower from his tomb 123*

V. B. MUNSON, SUCCESSOR TO
GEO. BRUCE'S SON & CO., 13 CHAMBERS STREET, NEW YORK.

STYLE 160.

60 a 30 A—3 lb. 4 oz.

8-POINT TITLE CONDENSED, No. 160.

\$2.95.

FRIENDS, ROMANS, COUNTRYMEN, LEND ME YOUR EARS!

**I come to bury Cæsar, not to praise him. The evil that men do lives after them,
the good is oft interred with their bones. So let it be with Cæsar.**

Brutus hath told you Cæsar was ambitious; 1234

40 a 20 A—3 lb. 2 oz.

10-POINT TITLE CONDENSED, No. 160.

\$2.30.

IF IT WERE SO, IT WAS A GRIEVOUS FAULT;

**And grievously hath Cæsar answered it. Here, under leave of Brutus
and the rest (for Brutus is an honourable man, so are
they all, all honourable men), 1234**

30 a 15 A—3 lb. 4 oz.

12-POINT TITLE CONDENSED, No. 160.

\$2.15.

COME I TO SPEAK IN CÆSAR'S FUNERAL.

**He was my friend, faithful and just to me: but Brutus says he
was ambitious; and Brutus, he is an honorable man.**

He hath brought many captives to Rome, 12

25 a 12 A—5 lb. 12 oz.

18-POINT TITLE CONDENSED, No. 160.

\$3.45.

WHOSE RANSOMS DID THE

**General coffers fill: Did this in Cæsar seem
ambitious? 1234**

25 a 12 A—7 lb. 12 oz.

22-POINT TITLE CONDENSED, No. 160.

\$4.35.

I SPEAK NOT TO DISPROVE

**What Brutus spoke; but here I am to
speak what I do know 1234**

V. B. MUNSON, SUCCESSOR TO
GEO. BRUCE'S SON & CO., 13 CHAMBERS STREET, NEW YORK.

STYLE 160.

20 a 10 A—10 lb. 6 oz.

28-POINT TITLE CONDENSED, No. 160.

\$5.80.

**I DESIRE NO MORE;
Do you prepare the body 123**

8 A—5 lb. 14 oz.

32-POINT TITLE CONDENSED, No. 160.

\$3.30.

KING RICHARD III. 2

15 a 8 A—14 lb. 12 oz.

40-POINT TITLE CONDENSED, No. 160.

\$8.00.

**HOW WEAK A THING
O Brutus! 123**

12 a 7 A—20 lb. 4 oz.

48-POINT TITLE CONDENSED, No. 160 A.

\$10.95.

**HEAR ME, FOR I
will speak 12**

5 a 5 A—16 lb.

48-POINT TITLE CONDENSED, No. 160 B.

\$8.65.

D'YE moind 5

V. B. MUNSON, SUCCESSOR TO
GEO. BRUCE'S SON & CO., 13 CHAMBERS STREET, NEW YORK.

STYLE 161.

60 a 30 A—1 lb. 6 oz. 5-POINT ALDINE, No. 161. \$2.50.

O, HELEN, GODDESS, NYMPH, PERFECT, DIVINE! TO WHAT, MY LOVE, SHALL I COMPARE THINE EYES!
Crystal is muddy. O, how ripe in show thy lips, those kissing cherries, tempting grow! That pure congealed white, high
Taurus' snow, fann'd with the eastern wind, turns to a crew when thou hold'st up thy hand:
O let me kiss this princess of pure white, this seal of bliss! 1234

60 a 30 A—2 lb. 2 oz. 6-POINT ALDINE, No. 161. \$2.45.

**O SPITE! O HELL! I SEE YOU ARE ALL BENT TO SET AGAINST ME FOR YOUR
Merriment. If you were civil and knew courtesy you would not do me thus much injury. Can you
not hate, as I know you do, but you must join, in souls, to mock me too! 1234**

60 a 30 A—2 lb. 10 oz. 7-POINT ALDINE, No. 161. \$2.60.

**IF YOU WERE MEN, AS MEN YOU ARE IN SHOW, YOU WOULD NOT
Treat a gentle lady so. To vow, and swear, and superpraise my parts, when, I am
sure, you hate me with your hearts. I will not trust you. 1234**

60 a 30 A—3 lb. 6 oz. 8-POINT ALDINE, No. 161. \$3.05.

**YOU BOTH ARE RIVALS, AND LOVE HERMIA, AND NOW
Both rivals, to mock Helena: a trim exploit, a manly enterprise, to conjure
tears up in a poor maid's eyes with your derision! 1234**

40 a 20 A—3 lb. 10 oz. 10-POINT ALDINE, No. 161. \$2.70.

**NEVER DID MOCKERS WASTE MORE IDLE BREATH.
Now I do perceive they have conjoin'd, all three, to fashion this
false sport in spite of me. Villains! 1234**

30 a 15 A—4 lb. 12-POINT ALDINE, No. 161. \$2.65.

**I PRAY YOU, THOUGH YOU MOCK ME,
Gentlemen, let her not hurt me; I was never curst;
Let her not strike me, I pray you. 123**

25 a 12 A—6 lb. 8 oz. 18-POINT ALDINE, No. 161. \$3.90.

**HAVE YOU NO MODESTY,
No shame, no touch of bashfulness? 123**

V. B. MUNSON, SUCCESSOR TO
GEO. BRUCE'S SON & CO., 13 CHAMBERS STREET, NEW YORK.

WATCH THE INDEX CLOSELY IN ORDERING, AS MANY CHANGES HAVE BEEN MADE IN THE SCHEME, PRICE AND BODIES. THIS APPLIES ESPECIALLY TO SCRIPT FACES, AS WE HAVE ADDED CARD FONTS TO NEARLY ALL OF SAME.

BRUCE TYPE FOUNDRY.

WANTON THE INDEX OBJECT IN
ORDERING HAS MANY CHANGES
HAVE BEEN MADE IN THE BODIES
THAT THE BODIES. THIS APPEARS
ESPECIALLY TO SORT FACES AS
WE HAVE ADDED CARD FONTS TO
NEARLY ALL OF SAME
BRUCE TYPE FOUNDRY

STYLE 161.

25 a 12 A—8 lb. 8 oz.

22-POINT ALDINE, No. 161.

\$4.75.

SAULT STE. MARIE, Michigan 2

20 a 10 A—12 lb.

28-POINT ALDINE, No. 161.

\$6.70.

ROCHESTER, New York 2

15 a 8 A—16 lb. 4 oz.

36-POINT ALDINE, No. 161.

\$9.10.

HAMILTON, Ohio 2

12 a 7 A—22 lb. 8 oz.

48-POINT ALDINE, No. 161.

\$12.15.

SALEM, Mass. 2

5 a 5 A—31 lb. 8 oz.

72-POINT ALDINE, No. 161.

\$16.40.

Rock Oil 5

4 a 4 A—48 lb. 8 oz.

96-POINT ALDINE, No. 161.

\$24.25.

Maine 7

V. B. MUNSON, SUCCESSOR TO
GEO. BRUCE'S SON & CO., 13 CHAMBERS STREET, NEW YORK.

STYLE 162 and 601.

60 a 30 A—2 lb. 14 oz. 8-POINT CONDENSED, No. 162. \$2.60.

ALL THE WORLD'S A STAGE, AND ALL THE MEN AND WOMEN MERELY
Players: they have their exits and their entrances; and one man in his time plays many parts, his acts being seven ages. At first the infant, 1234

40 a 20 A—2 lb. 10 oz. 10-POINT CONDENSED, No. 162. \$1.95.

MEWLING AND PUKING IN THE NURSE'S ARMS; THEN THE WHINING
Schoolboy, his satchel and shining morning face, creeping like snail unwillingly to school; and then the lover, sighing like furnace, with a 1234

30 a 15 A—3 lb. 6 oz. 12-POINT CONDENSED, No. 162. \$2.25.

WOEFUL BALLAD MADE TO HIS MISTRESS'
Eyebrow. Then, a soldier, full of strange oaths, and bearded like a pard, jealous in honor, sudden and 1234

30 a 15 A—3 lb. 12 oz. 14-POINT CONDENSED, No. 162. \$2.35.

QUICK IN QUARREL, SEEKING THE BUBBLE
Reputation even in the belching cannon's mouth, b'gosh! 1234

5 a 5 A—19 lb. 8 oz. 60-POINT EXTRA CONDENSED, No. 601. \$12.50.

West India 10

4 a 4 A—35 lb. 12 oz. 84-POINT EXTRA CONDENSED, No. 601. \$21.45.

Prominent

V. B. MUNSON, SUCCESSOR TO
GEO. BRUCE'S SON & CO., 13 CHAMBERS STREET, NEW YORK.

STYLE 163.

40 a 20 A—2 lb. 12 oz.

10-POINT CONDENSED, No. 163.

\$2.05.

ALL FOR OUR VANTAGE, MEN. THEN, IN GOD'S NAME, MARCH.

True hope is swift, and flies with swallow's wings; kings it makes gods and meaner creatures kings! King Richard III. Act 5, Scene 2. 1234

30 a 15 A—2 lb. 12 oz.

12-POINT CONDENSED, No. 163.

\$1.80.

GIVE ME ANOTHER HORSE! BIND UP MY WOUNDS!

Have mercy, Jesu!---Soft; I did but dream. O coward conscience, how dost thou afflict me! The lights burn blue. 1234

25 a 12 A—5 lb.

20-POINT CONDENSED, No. 163.

\$3.00.

THE HOUR IS NOW DEAD MIDNIGHT.

Cold fearful drops stand on my trembling flesh. What, do I fear myself? there's none else by 123

20 a 10 A—6 lb.

24-POINT CONDENSED, No. 163.

\$3.35.

HAVE YOU SLEPT, MY LORD?

Sweetest sleep and fairest-boding dreams. 123

20 a 10 A—8 lb.

28-POINT CONDENSED, No. 163.

\$4.50.

AWAKE AND WIN THE DAY!

O quiet untroubled soul, awake! 123

15 a 8 A—10 lb. 4 oz.

36-POINT CONDENSED, No. 163.

\$5.75.

WE MUST have knocks 123

V. B. MUNSON, SUCCESSOR TO
GEO. BRUCE'S SON & CO., 13 CHAMBERS STREET, NEW YORK.

STYLE 164.

60 a 30 A—1 lb. 12 oz.

6-POINT CONDENSED, No. 164.

\$2.05.

AS I INTEND TO PROSPER, AND REPENT, SO THRIVE I IN MY DANGEROUS AFFAIRS
Of hostile arms! myself myself confound! Heaven and fortune bar me happy hours! Day yield me not
thy light, nor night thy rest! Be opposite all planets of good luck to my proceeding!

60 a 30 A—3 lb.

8-POINT CONDENSED, No. 164.

\$2.70.

IF, WITH DEAR HEART'S LOVE, IMMACULATE DEVOTION, HOLY
Thoughts, I tender not thy beauteous princely daughter! In her consists my very
happiness, and thine; without her, follows to myself, 123

40 a 20 A—3 lb.

10-POINT CONDENSED, No. 164.

\$2.20.

AND THEE, HERSELF, THE LAND, AND MANY A CHRISTIAN
Soul, death, desolation, ruin and decay; it cannot be avoided but by
this. Therefore, be the attorney of my love to her. 123

30 a 15 A—3 lb. 8 oz.

12-POINT CONDENSED, No. 164.

\$2.30.

THE TYRANNOUS AND BLOODY ACT IS DONE;
The foulest and most arch deed of piteous massacre that
ever yet this fair land was guilty of. 123

25 a 12 A—5 lb. 8 oz.

18-POINT CONDENSED, No. 164.

\$3.30.

STAY; YET LOOK BACK WITH ME
To the tower. Pity, you ancient stones, those
tender babes within your walls. 123

25 a 12 A—8 lb.

22-POINT CONDENSED, No. 164.

\$4.50.

AND MUST SHE DIE FOR THIS?
O, let her live, and I'll corrupt her. 12

V. B. MUNSON, SUCCESSOR TO
GEO. BRUCE'S SON & CO., 13 CHAMBERS STREET, NEW YORK.

20 a 10 A—9 lb. 12 oz.

28-POINT CONDENSED, No. 164.

\$5.45.

LET ME BUT MEET YOU,
Ladies, one hour hence, and I'll
salute your grace 123

15 a 8 A—12 lb. 4 oz.

36-POINT CONDENSED, No. 164.

\$6.85.

SAD HEART, ADIEU!
Go thou to Richmond, and
fortune guide thee 123

12 a 7 A—21 lb. 4 oz.

48-POINT CONDENSED, No. 164.

\$11.45.

AM I KING?
'Tis so, m'lord, but
Edw. lives 12

STYLE 180.

60 a 30 A—2 lb. 8 oz. 5-POINT EXPANDED, No. 180. \$4.50.

ARE YOU NOT MOV'D, WHEN ALL THE SWAY OF
Earth shakes like a thing unfirm? O Cicero, I have seen tempests, when
the scolding winds have riv'd the knotty oaks; and I have
seen the ambitious ocean swell, and rage, 1234

30 A—1 lb. 4 oz. 5½-POINT EXPANDED, No. 180. \$1.80.

AND FOAM, TO BE EXALTED WITH THE THREAT'NING
CLOUDS; BUT NEVER TILL TO-NIGHT, NEVER TILL NOW
DID I GO THROUGH A TEMPEST OF FIRE. 123

60 a 30 A—3 lb. 4 oz. 6-POINT EXPANDED, No. 180. \$3.80.

EITHER THERE IS CIVIL STRIFE IN HEAVEN,
Or else the world, too saucy with the gods, incenses them to
send destruction. Why, saw you anything more
wonderful? A common slave, 123

60 a 30 A—5 lb. 4 oz. 8-POINT EXPANDED, No. 180. \$4.75.

YOU KNOW HIM WELL BY SIGHT,
Held up his left hand, which did flame and burn
like twenty torches joined, and yet his
hand, not sensible of fire, 123

40 a 20 A—5 lb. 10 oz. 10-POINT EXPANDED, No. 180. \$4.15.

REMAIN'D UNSCORCH'D.
Besides, I have not since put up my sword,
against the capital I met a lion, who
glared upon me and went 123

V. B. MUNSON, SUCCESSOR TO
GEO. BRUCE'S SON & CO., 13 CHAMBERS STREET, NEW YORK.

STYLES 180 AND 330.

30 a 15 A—7 B.

12-POINT EXPANDED, No. 180.

\$4.60.

DO YOU KNOW THEM?
No, sir; their hats about their
ears are pluck'd, and 123

25 a 12 A—12 B.

18-POINT EXPANDED, No. 180.

\$7.20.

THEIR FACES
Buried in their cloaks,

10 A—9 B. 8 oz.

24-POINT EXPANDED, No. 180.

\$5.30.

VERMONT 23

30 a 15 A—2 B. 10 oz.

6-POINT ANTIQUE EXTENDED, No. 330.

\$3.05.

MUSIC OFT HATH SUCH CHARM
To make bad good, and good provoke to
harm. I cry you mercy, sir 128

30 a 15 A—4 B. 8 oz.

8-POINT ANTIQUE EXTENDED, No. 330.

\$4.05.

AND WELL COULD WISH
You had not found me here quite
so musical; I do, indeed 12

30 a 10 A—4 B. 10 oz.

10-POINT ANTIQUE EXTENDED, No. 330.

\$3.45.

THERE IS WRITTEN
In your brow honesty, 12

20 a 10 A—7 B.

12-POINT ANTIQUE EXTENDED, No. 330.

\$4.60.

PAINING, SIR,
I have been told, is 12

V. B. MUNSON, SUCCESSOR TO
GEO. BRUCE'S SON & CO., 13 CHAMBERS STREET, NEW YORK.

STYLE 182.

60 a 30 A—3 lb. 4 oz. 6-POINT TITLE EXPANDED, No. 182. \$3.80.

WELL, BRUTUS, THOU ART NOBLE; YET
I see thy honourable metal may be wrought from that it is dispos'd:
Therefore 'tis meet that noble minds keep ever with
their likes, for who so firm that 1234

60 a 30 A—5 lb. 10 oz. 8-POINT TITLE EXPANDED, No. 182. \$5.05.

CANNOT BE SEDUC'D? CÆSAR DOTH
Bear me hard; but he loves Brutus. If I were
Brutus now, and he were Cassius, he
should not humour me. 123

40 a 20 A—5 lb. 14 oz. 10-POINT TITLE EXPANDED, No. 182. \$4.35.

I WILL THIS VERY NIGHT,
In several hands, in his windows throw,
as if they came from numerous
citizens, writings, 123

30 a 15 A—6 lb. 6 oz. 12-POINT TITLE EXPANDED, No. 182. \$4.20.

ALL TENDING TO THE
Great opinion that Rome holds of
his name; wherein obscurely
his ambition shall 123

25 a 12 A—9 lb. 6 oz.' 18-POINT TITLE EXPANDED, No. 182. \$5.65.

BE GLANCED AT;
And then let Cæsar seat him
sure; for we shall
shake him 12

V. B. MUNSON, SUCCESSOR TO
GEO. BRUCE'S SON & CO., 13 CHAMBERS STREET, NEW YORK.

STYLES 602 AND 630.

60 a 30 A—2 lb. 2 oz. 8-POINT EXTRA CONDENSED, No. 602. \$3.40.

CASSIUS, BE NOT DECEIV'D: IF I HAVE VEILED MY LOOK, I TURN THE TROUBLE OF MY COUNTENANCE
Merely upon myself. Vexed I am, of late, with passions of some difference, conceptions only proper to myself, which give
some soil, perhaps, to my behaviour; but let not therefore my good friends be griev'd, 1234567890

40 a 20 A—2 lb. 10-POINT EXTRA CONDENSED, No. 602. \$2.60.

AMONG WHICH NUMBER, CASSIUS, BE YOU ONE; NOR CONSTRUE ANY FURTHER MY NEGLECT,
Than that poor Brutus, with himself at war, forgets the shows of love to other men. Then, Brutus, I have
mistook your passion: by means whereof this breast of mine hath buried 1234567890

30 a 15 A—2 lb. 12-POINT EXTRA CONDENSED, No. 602. \$2.30.

THOUGHTS OF GREAT VALUE, WORTHY COGITATIONS; TELL ME, GOOD
Brutus, can you see your face? No, Cassius, for the eye sees not itself but by reflection, by
some other things. 'Tis just, and it is much lamented, 1234567890

12 A—1 lb. 14 oz. 18-POINT SKELETON, No. 630. \$1.90.

THIS MURTHEROUS SHAFT THAT'S SHOT HATH NOT
YET LIGHTED, AND OUR SAFEST WAY IS TO
AVOID THE AIM; MEN, TO HORSE 123

10 A—2 lb. 12 oz. 24-POINT SKELETON, No. 630. \$2.50.

LET US NOT BE DAINY OF LEAVE-TAKING,
BUT SHIFT AWAY: THERE'S WARRANT
IN THEFT THAT STEALS ITSELF 12

V. B. MUNSON, SUCCESSOR TO
GEO. BRUCE'S SON & CO., 13 CHAMBERS STREET, NEW YORK.

STYLE 603.

60 a 30 A—1 lb. 14 oz. 8-POINT EXTRA CONDENSED, No. 603. \$3.00.

I CANNOT TELL WHAT YOU AND OTHER MEN THINK OF THIS LIFE; BUT, FOR MY SINGLE SELF, I HAD AS LIEF NOT BE
As live to be in awe of such a thing as I myself. I was born free as Cæsar; so were you; we both have fed as well; and
we can both endure the winter's cold as well as he: for once, upon a raw and gusty day, the
troubled Tiber chafing with her shores, Cæsar said to me, 1234567890

40 a 20 A—1 lb. 14 oz. 10-POINT EXTRA CONDENSED, No. 603. \$2.45.

“DAR’ST THOU, CASSIUS, NOW, LEAP IN WITH ME INTO THIS ANGRY FLOOD, AND SWIM TO
Yonder point?” Upon the word, accoutred as I was, I plunged in, and bade him follow: so indeed he did.
The torrent roar’d, and we did buffet it with lusty sinews, throwing it aside and
stemming it with hearts of controversy. 1234567890

30 a 15 A—2 lb. 12-POINT EXTRA CONDENSED, No. 603. \$2.30.

BUT ERE WE COULD ARRIVE THE POINT PROPOS’D, CÆSAR CRIED “HELP
Me, Cassius, or I sink.” I, as Æneas, our great ancestor, did from the flames of Troy upon
his shoulder the old Anchises bear, so from the waves of Tiber did I,
the tired Cæsar. And this man has now 1234567890

25 a 12 A—2 lb. 14 oz. 18-POINT EXTRA CONDENSED, No. 603. \$2.90.

BECOME A GOD, AND CASSIUS IS A WRETCHED CREATURE, AND
Must bend his body if Cæsar carelessly but nod on him. He had a fever when
he was in Spain, and when the fit was on him 1234567890

25 a 12 A—4 lb. 22-POINT EXTRA CONDENSED, No. 603. \$3.60.

I DID MARK HOW HE DID SHAKE; ’TIS TRUE, THIS GOD
Did shake; his coward lips did from their color fly, and that same eye
whose bend doth awe the world did lose its lustre; 123

V. B. MUNSON, SUCCESSOR TO
GEO. BRUCE'S SON & CO., 13 CHAMBERS STREET, NEW YORK.

STYLE 603.

20 a 10 A—5 lb. 2 oz. 28-POINT EXTRA CONDENSED, No. 603. \$4.40.

THE HOUSE WAS PACKED AND CROWDED

To the doors and to the dome, The play began a-moving like
a petrel o'er the foam 1234

15 a 8 A—6 lb. 6 oz. 36-POINT EXTRA CONDENSED, No. 603. \$5.20.

THE STRAINS WERE LIQUID MELODY

The jokes were very fine, And not the sort that 12

12 a 6 A—7 lb. 8 oz. 48-POINT EXTRA CONDENSED, No. 603. \$5.40.

CAUSE A CHILL TO WANDER UP

The spine; In fact the merry travesty came 12

10 a 5 A—10 lb. 60-POINT EXTRA CONDENSED, No. 603. \$6.40.

BOOMING WITH a hop, and it 12

V. B. MUNSON, SUCCESSOR TO
GEO. BRUCE'S SON & CO., 13 CHAMBERS STREET, NEW YORK.

STYLE 190.

10 a 5 A—19 lb. 8 oz.

48-POINT ELONGATED ITALIC, No. 190.

\$10.55.

BRUCE'S TYPE

*Is unequalled in
any respect 23*

4 a 4 A—30 lb.

84-POINT ELONGATED ITALIC, No. 190.

\$15.00.

HISTORY

National 8

V. B. MUNSON, SUCCESSOR TO
GEO. BRUCE'S SON & CO., 13 CHAMBERS STREET, NEW YORK.

GOTHIC ALIGNED—HEAVY

50 A—1 lb. 3 oz. 6-POINT GOTHIC ALIGNED—HEAVY, No. 1. \$1.40.

THE EDITORS OF THE BUNGTOWN BLISTER, AFTER AN UNAVOIDABLE DELAY FAR BEYOND THE TIME LIMITED
IN THEIR PROPOSALS, PRESENT SUBSCRIBERS WITH THE FIRST NUMBER JULY 1, 1900,
FEELING ASSURED THAT A DISCERNING PUBLIC WILL NOT BE

50 A—1 lb. 5 oz. 6-POINT GOTHIC ALIGNED—HEAVY, No. 2. \$1.50.

DILATORY IN EXHIBITING A GREENBACK APPRECIATION OF OUR ENTERPRISE. REGARDING THE
EXCELLENT TYPOGRAPHICAL APPEARANCE OF THE BLISTER, WE NEED ONLY SAY
THAT OUR ENTIRE PLANT WAS PURCHASED FROM THE

50 A—1 lb. 8 oz. 6-POINT GOTHIC ALIGNED—HEAVY, No. 3. \$1.75.

CELEBRATED ESTABLISHMENT OF GEORGE BRUCE'S SON & CO. NEW YORK CITY.
AN INSTITUTION WHICH HAS NO SUPERIOR AND FEW EQUALS AMONG
THE TYPE FOUNDERS OF THIS OR ANY OTHER COUNTRY

50 A—1 lb. 14 oz. 6-POINT GOTHIC ALIGNED—HEAVY, No. 4. \$2.20.

POLITICALLY, WE FRANKLY ACKNOWLEDGE A TENDER REGARD FOR THE
CANDIDATE WITH THE BIGGEST WAD. WE ARE SOCIALIST
ANARCHIST, DEMOCRAT, REPUBLICAN, OR ANY-

50 A—2 lb. 4 oz. 6-POINT GOTHIC ALIGNED—HEAVY, No. 5. \$2.60.

THING ELSE, ACCORDING TO WHICH CANDIDATE OR PARTY
SECURES OUR POWERFUL SUPPORT AND INFLUENCE.
IN SHORT, WE ARE OUT FOR THE STUFF

"THE CYNIC"

EVEN IN THIS AGE OF PROGRESS

AMONG THE NATIONS THERE IS TO BE FOUND THE DISCONTENTED
GROWLING INDIVIDUAL,

WHO, SITTING ALOFT WITH HEAD ABOVE THE CLOUDS, VIEWS DIMLY
THROUGH THE INTERVENING FOG THE WORKS OF
LESS ELEVATED MORTALS.

AT EACH PLAUDIT OF THE MASSES

HE WITHDRAWS MORE SECURELY WITHIN THE GLOOM, AND,
THUS ENVELOPED, GROWLS FORTH.

THE CYNIC AND OBSERVER OF THE TIMES

12345 M M M M M M M M 67890

V. B. MUNSON, SUCCESSOR TO
GEO. BRUCE'S SON & CO., 13 CHAMBERS STREET, NEW YORK.

GOTHIC ALIGNED—LIGHT

50 A—14 oz. 6-POINT GOTHIC ALIGNED—LIGHT, No. 6. \$1.00.

I COULD A TALE UNFOLD WHOSE LIGHTEST WORD WOULD HARROW UP THY VERY SOUL, CAUSE THY YOUNG BLOOD TO FREEZE UP IN THY VEINS,
AND EACH PARTICULAR HAIR TO STAND ERECT LIKE QUILLS ON THE BACK OF THE FRETFUL PORCUPINE

50 A—1 lb. 6-POINT GOTHIC ALIGNED—LIGHT, No. 7. \$1.15.

NOW IS THE WINTER OF OUR DISCONTENT MADE GLORIOUS SUMMMER BY THIS SUN OF YORK; AND ALL THE CLOUDS
THAT LOW'R'D UPON OUR HOUSE IN THE DEEP BOSOM OF THE OCEAN BURIED

50 A—1 lb. 4 oz. 6-POINT GOTHIC ALIGNED—LIGHT, No. 8. \$1.45.

NOW ARE OUR BROWS BOUND WITH VICTORIOUS WREATHS; OUR BRUISED ARMS HUNG UP
FOR MONUMENTS; OUR STERN ALARUMS CHANG'D TO MERRY MEETINGS

50 A—1 lb. 10 oz. 6-POINT GOTHIC ALIGNED—LIGHT, No. 9. \$1.90.

I'M OLD MAN THUNDER! LO, I COME WITH RUSH OF WIND AND ROLL OF
DRUM, AND ALL THE WORLD HAD BETTER STAND FROM UNDER

<div style="border: 1px solid black; padding: 5px;"> <p style="text-align: center;">GEO. BRUCE'S SON & CO.</p> <p style="text-align: center;">WERE AWARDED MEDALS</p> <p style="text-align: center;">...AT...</p> <p>VIENNA - - - 1873 PHILADELPHIA 1876 PARIS - - - 1878 SYDNEY - - 1879 MELBOURNE - 1880 ANTWERP - - 1885</p> <p style="text-align: center;">..FOR..</p> <p style="text-align: center;">DURABILITY, BEAUTY OF FINISH</p> <p style="text-align: center;">..AND..</p> <p style="text-align: center;">GENERAL EXCELLENCE</p> </div>	<table style="width: 100%; border: none;"> <tr> <td style="width: 25%;">TYPE</td> <td style="width: 25%;">BRASS RULE</td> <td style="width: 25%;">FURNITURE</td> <td style="width: 25%;">FRAMES</td> </tr> <tr> <td>BORDERS</td> <td>BRASS DASHES</td> <td>WOOD OR METAL</td> <td>CASES</td> </tr> <tr> <td>ORNAMENTS</td> <td>CIRCLES AND OVALS</td> <td>LEADS AND SLUGS</td> <td>ETC. ETC.</td> </tr> </table>	TYPE	BRASS RULE	FURNITURE	FRAMES	BORDERS	BRASS DASHES	WOOD OR METAL	CASES	ORNAMENTS	CIRCLES AND OVALS	LEADS AND SLUGS	ETC. ETC.	<div style="border: 1px solid black; padding: 5px; width: fit-content; margin: 0 auto;"> <p style="font-size: small;">THE PIONEER ESTABLISHMENT OF AMERICA IN THE MANUFACTURE OF TYPE AND PRINTING MATERIAL</p> </div> <p style="font-size: x-large; font-weight: bold; margin: 10px 0;"><u>BRUCE'S NEW YORK TYPE FOUNDRY</u></p> <p style="font-size: small;">ESTABLISHED IN 1813</p> <p style="font-weight: bold; margin: 10px 0;">13 CHAMBERS STREET NEW YORK</p> <p style="font-weight: bold; margin: 10px 0;">V. B. MUNSON</p> <p style="font-size: x-small;">SUCCESSOR TO GEO. BRUCE'S SON & CO.</p>
TYPE	BRASS RULE	FURNITURE	FRAMES											
BORDERS	BRASS DASHES	WOOD OR METAL	CASES											
ORNAMENTS	CIRCLES AND OVALS	LEADS AND SLUGS	ETC. ETC.											

432: mmm Mmm 1234

V. B. MUNSON, SUCCESSOR TO
GEO. BRUCE'S SON & CO., 13 CHAMBERS STREET, NEW YORK.

STYLE 200.

30 A—1 lb. 12 oz.

6-POINT GOTHIC, No. 200.

\$2.05.

AND YESTERNIGHT, AT SUPPER, YOU SUDDENLY AROSE, AND WALKED ABOUT,
MUSING AND SIGHING, WITH YOUR ARMS ACROSS: AND WHEN I
ASKED YOU WHAT THE MATTER WAS, 1234

30 A—2 lb.

8-POINT GOTHIC, No. 200.

\$1.80.

YOU STAR'D UPON ME WITH UNGENTLE LOOKS: I URG'D
YOU FURTHER; THEN YOU SCRATCH'D YOUR
HEAD, AND IMPATIENTLY 1234

20 A—2 lb.

10-POINT GOTHIC, No. 200.

\$1.50.

STAMP'D YOUR BIG FOOT: YET I INSISTED, YET
YOU ANSWER'D NOT; BUT WITH AN
ANGRY WAFTURE OF 1234

15 A—2 lb. 8 oz.

12-POINT GOTHIC, No. 200.

\$1.65.

YOUR HAND, GAVE SIGN TO ME TO
LEAVE YOU: SO I DID, FEARING
TO STRENGTHEN THE 123

15 A—4 lb. 2 oz.

16-POINT GOTHIC, No. 200.

\$2.50.

IMPATIENCE WHICH SEEM'D
TOO MUCH ENKINDLED
DEAR MY LORD 12

V. B. MUNSON, SUCCESSOR TO
GEO. BRUCE'S SON & CO., 13 CHAMBERS STREET, NEW YORK.

STYLE 200.

12 A—5 lb. 10 oz.

20-POINT GOTHIC, No. 200.

\$3.40.

**WE'LL BRING HIM TO
HIS HOUSE WITH
HURRAHS 123**

10 A—6 lb. 8 oz.

24-POINT GOTHIC, No. 200.

\$3.65.

**LAY ON, MACDUFF,
AND DAMN'D BE
HE WHO 123**

8 A—10 lb. 10 oz.

36-POINT GOTHIC, No. 200.

\$5.95.

**FIRST CRIES
HOLD, 123**

5 A—13 lb. 6 oz.

48-POINT GOTHIC, No. 200.

\$7.25.

**ENOUGH!
NUF 12**

V. B. MUNSON, SUCCESSOR TO
GEO. BRUCE'S SON & CO., 13 CHAMBERS STREET, NEW YORK.

STYLE 201.

60 a 30 A—1 lb. 14 oz.

6-POINT GOTHIC, No. 201.

\$2.20.

A BLESSED LABOUR, MY MOST SOVEREIGN LORD. AMONG THIS PRINCELY HEAP,

If any here, by false intelligence or wrong surmise, hold me a foe; if I unwittingly, or in my rage, have aught committed that is hardly borne by any in this presence, I desire to reconcile me to his friendly peace; 'tis death to me to be at enmity; 1234567890

60 a 30 A—3 lb. 2 oz.

8-POINT GOTHIC, No. 201.

\$2.80.

I HATE IT, AND DESIRE ALL GOOD MEN'S LOVE. FIRST, MADAM,

I entreat true peace of you, which I will purchase with my duteous service; of you, my noble cousin Buckingham, if ever any grudge were lodg'd between us; of you, and you, 1234567890

40 a 20 A—3 lb.

10-POINT GOTHIC, No. 201.

\$2.25.

LORD RIVERS, AND OF DORSET, THAT ALL WITHOUT

Desert have frown'd on me; of you, Lord Woodville, and Lord Scales, of you; dukes, earls, lords, gentlemen: indeed, of all. 123

30 a 15 A—3 lb. 6 oz.

12-POINT GOTHIC, No. 201.

\$2.25.

I DO NOT KNOW THAT ENGLISHMAN ALIVE

With whom my soul is any jot at odds, more than the infant that is born to-night. Believe me, gentlemen. 123

25 a 12 A—6 lb. 6 oz.

18-POINT GOTHIC, No. 201.

\$3.85.

NOT TO RELENT IS BEASTLY,

Savage, devilish. My friend, I spy some pity in thy sinister looks. 123

20 a 10 A—10 lb. 6 oz.

24-POINT GOTHIC, No. 201.

\$5.80.

PEACE, CHILDREN;

The king doth love you 13

V. B. MUNSON, SUCCESSOR TO
GEO. BRUCE'S SON & CO., 13 CHAMBERS STREET, NEW YORK.

STYLE 202.

60 a 30 A—2 lb. 2 oz.

6-POINT GOTHIC, No. 202.

\$2.45.

HAVE I A TONGUE TO DOOM MY BROTHER'S DEATH, AND SHALL THAT
Tongue give pardon to a slave? My brother kill'd no man, his fault was thought, and yet his
punishment was bitter death. Who sued to me for him? who, in my wrath,
kneel'd at my feet, and bade me be advis'd? 1234567890

60 a 30 A—3 lb. 6 oz.

8-POINT GOTHIC, No. 202.

\$3.05.

WHO SPOKE OF BROTHERHOOD? WHO SPOKE OF LOVE?
Who told me how the poor soul did forsake the mighty Warwick, and did fight
for me? Who told me in the field at Tewksbury, when
Oxford had me down, he rescu'd me, 1234

40 a 20 A—3 lb. 2 oz.

10-POINT GOTHIC, No. 202.

\$2.30.

AND SAID, "DEAR BROTHER, LIVE, AND BE A KING?"
Who told me, when we both lay in the field, frozen almost to death,
how he did lap me even in his garments, and did give
himself, all thin and naked, to the 12345

30 a 15 A—3 lb. 12 oz.

12-POINT GOTHIC, No. 202.

\$2.50.

NUMB-COLD NIGHT? ALL THIS FROM MY
Remembrance brutish wrath sinfully plucked, and not a
man of you had so much grace to put it in
my mind. But when your carters, 123

25 a 12 A—6 lb. 8 oz.

18-POINT GOTHIC, No. 202.

\$3.90.

OR YOUR WAITING VASSALS,
Have done a drunken slaughter, have
defac'd the precious image of
our dear Redeemer 123

V. B. MUNSON, SUCCESSOR TO
GEO. BRUCE'S SON & CO., 13 CHAMBERS STREET, NEW YORK.

STYLE 202.

25 a 12 A—9 B. 8 oz.

22-POINT GOTHIC, No. 202.

\$5.30.

YOU STRAIGHT ARE ON
Your knees for pardon, pardon;
and I, unjustly too, must
grant it you; 123

20 a 10 A—11 B. 14 oz.

28-POINT GOTHIC, No. 202.

\$6.65.

FOR MY BROTHER
Not a man would speak a
word. The proudest
of you all 123

15 a 8 A—16 B. 14 oz.

36-POINT GOTHIC, No. 202.

\$9.45.

ARE BEHOLDEN
To him; yet none of
you would 123

V. B. MUNSON, SUCCESSOR TO
GEO. BRUCE'S SON & CO., 13 CHAMBERS STREET, NEW YORK.

STYLE 203.

60 a 30 A—2 lb.

5-POINT GOTHIC, No. 203.

\$3.60.

**METHOUGHT THAT I HAD BROKEN FROM THE TOWER, AND WAS
Embarked to cross to Burgundy; and in my company my brother Gloster, who from
my cabin tempted me to walk upon the hatches; 1234567890**

60 a 30 A—2 lb. 14 oz.

6-POINT GOTHIC, No. 203.

\$3.35.

**THERE WE LOOK'D TOWARD ENGLAND, AND CITED UP A
Thousand heavy times, during the wars of York and Lancaster, that
had befall'n us. As we pac'd along upon 1234**

60 a 30 A—4 lb. 12 oz.

8-POINT GOTHIC, No. 203.

\$4.30.

**THE GIDDY FOOTING OF THE HATCHES,
Methought that Gloster stumbled, and, falling, struck
me, that thought to stay him, 1234**

40 a 20 A—5 lb.

10-POINT GOTHIC, No. 203.

\$3.70.

**OVERBOARD, INTO THE TUMBLING
Billows of the main. O Lord! methought what
pain it was to drown! 1234**

30 a 15 A—5 lb. 8 oz.

12-POINT GOTHIC, No. 203.

\$3.65.

**WHAT DREADFUL NOISE OF
Water in mine ears! The sights of ugly
death within mine eyes! 123**

25 a 12 A—9 lb. 2 oz.

18-POINT GOTHIC, No. 203.

\$5.50.

**I THOUGHT I SAW A
Thousand fearful wrecks 12**

20 a 10 A—13 lb.

24-POINT GOTHIC, No. 203.

\$7.30.

**THOUSAND MEN
Gnaw'd by fishes! 12**

V. B. MUNSON, SUCCESSOR TO
GEO. BRUCE'S SON & CO., 13 CHAMBERS STREET, NEW YORK.

STYLE 204.

30 a 15 A—3 lb. 12 oz.

12-POINT GOTHIC, No. 204.

\$2.50.

A SENTRY STROLLED LAZILY OUT INTO
The roadway, dragging his gun by the bayonet 123

25 a 12 A—6 lb.

18-POINT GOTHIC, No. 204.

\$3.60.

HIS CAPTAIN FOLLOWED HIM
From the post-house, throwing a 123

20 a 10 A—8 lb.

24-POINT GOTHIC, No. 204.

\$4.50.

HALF-SMOKED CIGARRO
To a ragged urchin beside 123

15 a 8 A—10 lb. 8 oz.

30-POINT GOTHIC, No. 204.

\$5.90.

THE ROLLING SEA
She solemnly sailed 123

12 a 6 A—12 lb. 4 oz.

36-POINT GOTHIC, No. 204.

\$6.85.

ADVERTisement 12

5 a 5 A—12 lb.

48-POINT GOTHIC, No. 204.

\$6.50.

METROpolitan 2

V. B. MUNSON, SUCCESSOR TO
GEO. BRUCE'S SON & CO., 13 CHAMBERS STREET, NEW YORK.

SYTLE 205.

30 A—1 lb. 4 oz.

6-POINT GOTHIC, No. 205.

\$1.45.

BUT THE SOLID STREETS SOON GAVE WAY TO OPEN PLACES AND
LOW MUD CABINS, WHERE THE HORSES' HOOFS 1234567

30 A—2 lb. 4 oz.

8-POINT GOTHIC, No. 205.

\$2.00.

BEAT ON A SUN-BAKED ROAD, AND WHERE THE
INHABITANTS SAT LAZILY BEFORE 12345

20 A—2 lb. 6 oz.

10-POINT GOTHIC, No. 205.

\$1.75.

THE DOOR IN THE FADING LIGHT, WITH
NO KNOWLEDGE OF CHANGES 123

15 A—2 lb. 8 oz.

12-POINT GOTHIC, No. 205.

\$1.65.

THAT THE DAY HAD WROUGHT IN
THE CITY, AND WITH BUT 1234

12 A—3 lb. 12 oz.

18-POINT GOTHIC, No. 205.

\$2.25.

MOMENTARY INTEREST IN
A BLACK CARRIAGE 12

10 A—5 lb. 8 oz.

24-POINT GOTHIC, No. 205.

\$3.10.

AND DISTINGUISHED
OCCUPANTS 123

V. B. MUNSON, SUCCESSOR TO
GEO. BRUCE'S SON & CO., 13 CHAMBERS STREET, NEW YORK.

STYLE 206.

30 a 30 A—2 lb. 2 oz.

6-POINT GOTHIC, No. 206.

\$2.45.

**IN THE LOW LANDS, WHERE THE FEVER LAY, THE MIST
Rose above the level of their heads and completely enshrouded
them in a curtain of fog, and 1234567890**

25 a 25 A—3 lb.

8-POINT GOTHIC, No. 206.

\$2.70.

**DEW FELL HEAVILY, PENETRATING THEIR
Clothing and chilling their heated bodies so that the
sweating horses were in a lather 1234**

20 a 20 A—3 lb. 10 oz.

10-POINT GOTHIC, No. 206.

\$2.70.

**THEY HAD SETTLED INTO A STEADY
Gallop now and ten or more miles and several
other things had been left behind 123**

15 a 15 A—3 lb. 14 oz.

12-POINT GOTHIC, No. 206.

\$2.55.

**THE HORSES HAD DROPPED
Into a quiet walk, the driver into a loud
snooze, snoring eloquently 123**

12 a 12 A—6 lb.

18-POINT GOTHIC, No. 206.

\$3.60.

**THE PASSENGERS GOT
Out and dropped into a tavern
to see a man 123**

10 a 10 A—7 lb. 4 oz.

24-POINT GOTHIC, No. 206.

\$4.05.

**OR TAKE A DROP
Of white man's burden 123**

V. B. MUNSON, SUCCESSOR TO
GEO. BRUCE'S SON & CO., 13 CHAMBERS STREET, NEW YORK.

STYLES 206 AND 208.

8 a 8 A—10 lb. 2 oz.

30-POINT GOTHIC, No. 206.

\$5.65.

HE PAUSED
Smites his thigh 12

6 a 6 A—11 lb. 8 oz.

36-POINT GOTHIC, No. 206.

\$6.45.

LOOKS brave 2

5 a 5 A—15 lb. 12 oz.

48-POINT GOTHIC, No. 206.

\$8.50.

SAYS enuf 2

20 a 20 A—3 lb. 12 oz.

10-POINT GOTHIC ITALIC, No. 208.

\$2.80.

SOME LIKE UPON THE WINDING STYX
To wield the bending oar, nor care they 123

15 a 15 A—4 lb.

12-POINT GOTHIC ITALIC, No. 208.

\$2.65.

THOUGH THEIR BACKS ARE
Burned, and every muscle sore 123

8 a 8 A—10 lb. 12 oz.

30-POINT GOTHIC ITALIC, No. 208.

\$6.00.

BASEBALL
National game 123

V. B. MUNSON, SUCCESSOR TO
GEO. BRUCE'S SON & CO., 13 CHAMBERS STREET, NEW YORK.

STYLE 207.

60 a 30 A—1 lb. 12 oz. 6-POINT GOTHIC, No. 207. \$2.05.

WITH REFERENCE TO THE BURIAL PLACE OF JOHANN GUTENBURG, IT IS
Remarkable that an error should have existed up to the present day. It has been hitherto the
opinion that Johann Genszfleisch, called Gutenberg 12345

60 a 30 A—2 lb. 12 oz. 8-POINT GOTHIC, No. 207. \$2.50.

WAS BURIED IN THE FRANCISCAN MONASTERY OF MENTZ
This, however, has been proved to be erroneous by an ancient record discovered by Dr.
Bockenheimer, from which it appears that 12345

40 a 20 A—3 lb. 4 oz. 10-POINT GOTHIC, No. 207. \$2.40.

THE INVENTOR OF PRINTING RESTS IN THE OLD
Dominican Monastery in the same town. The document in which
this interesting fact is recorded is the 1234

30 a 15 A—3 lb. 6 oz. 12-POINT GOTHIC, No. 207. \$2.25.

MORTUARY BOOK OF THE DOMINICAN
Monastery of Mentz. Adam Gelthus, not long after the
great printer's death, caused 1234

30 a 15 A—4 lb. 2 oz. 14-POINT GOTHIC, No. 207. \$2.55.

A TABLET TO BE ERECTED TO HIS
Memory in the Church of St. Francis, bearing an
inscription which we have 1234

25 a 12 A—5 lb. 6 oz. 18-POINT GOTHIC, No. 207. \$3.20.

PERSONALLY COPIED AND
Laboriously translated, but which we are
compelled to omit 1234

V. B. MUNSON, SUCCESSOR TO
GEO. BRUCE'S SON & CO., 13 CHAMBERS STREET, NEW YORK.

STYLE 240.

60 a 30 A—1 lb. 12 oz. 6-POINT GOTHIC CONDENSED, No. 240. \$2.05.

NO, NO, MY DREAM WAS LENGTHEN'D AFTER LIFE; O, THEN BEGAN THE TEMPEST
To my soul! I pass'd, methought, the melancholy flood with that sour ferryman which the poets write of,
unto the kingdom of perpetual night. The first that there did greet my stranger soul
was my great father-in-law, renowned Warwick, who spake 1234

60 a 30 A—3 lb. 8-POINT GOTHIC CONDENSED, No. 240. \$2.70.

ALoud, "WHAT SCOURGE FOR PERJURY CAN THIS DARK MONARCHY
Afford false Clarence?" And so he vanish'd. Then came wandering by a shadow
like an angel, with bright hair dabbled in blood, and he 1234

40 a 20 A—3 lb. 4 oz. 10-POINT GOTHIC CONDENSED, No. 240. \$2.40.

SHRIEK'D OUT ALoud, "CLARENCE IS COME, FALSE,
Fleeting, perjured Clarence, that stabb'd me in the field at Whitby;
seize on him, furies, take him unto torment!" 1234

30 a 15 A—3 lb. 10 oz. 12-POINT GOTHIC CONDENSED, No. 240. \$2.40.

WITH THAT, METHOUGHT, A LEGION OF FOUL
Fiends environ'd me, and howled into mine ears such
hideous cries that with the very noise 1234

25 a 12 A—5 lb. 8 oz. 18-POINT GOTHIC CONDENSED, No. 240. \$3.30.

I TREMBLING AWAK'D, AND FOR A
Season after could not believe but that I was
in hell, so terrible was the effect 1234

25 a 12 A—7 lb. 14 oz. 22-POINT GOTHIC CONDENSED, No. 240. \$4.40.

MY DREAM DID LEAVE ON ME.
I pray you, keeper, stay near me. 1234

V. B. MUNSON, SUCCESSOR TO
GEO. BRUCE'S SON & CO., 13 CHAMBERS STREET, NEW YORK.

WATCH THE INDEX CLOSELY IN ORDERING, AS MANY CHANGES HAVE BEEN MADE IN THE SCHEME, PRICE AND BODIES. THIS APPLIES ESPECIALLY TO SCRIPT FACES, AS WE HAVE ADDED CARD FONTS TO NEARLY ALL OF SAME.

BRUCE TYPE FOUNDRY.

WE WOULD LIKE TO THANK YOU FOR YOUR ORDER.
YOUR ORDER HAS BEEN RECEIVED AND WE WILL
PROCESS IT AS SOON AS POSSIBLE. WE WILL
CONTACT YOU IF WE HAVE ANY QUESTIONS.
THANK YOU FOR CHOOSING US.

STYLE 240.

20 a 10 A—9 B. 4 oz. 28-POINT GOTHIC CONDENSED, No. 240. \$5.20.

SORROW BREAKS SEASONS
Makes night morning and 1234

15 a 8 A—11 B. 12 oz. 36-POINT GOTHIC CONDENSED, No. 240. \$6.60.

THE NOONTIDE NIGHT.
How now, my hearties 12

12 a 7 A—15 B. 12 oz. 48-POINT GOTHIC CONDENSED, No. 240 A. \$8.50.

I CALL THEE NOT
Thy deadlier stroke 12

5 a 5 A—10 B. 2 oz. 48-POINT GOTHIC CONDENSED, No. 240 B. \$5.50.

BRACKENBURY
Romeo and Juliet 12

V. B. MUNSON, SUCCESSOR TO
GEO. BRUCE'S SON & CO., 13 CHAMBERS STREET, NEW YORK.

STYLE 241.

60 a 30 A—2 lb. 6-POINT GOTHIC CONDENSED, No. 241. \$2.30.

WHAT! WERE YOU SNARLING ALL BEFORE I CAME, READY TO CATCH EACH OTHER
By the throat; and so turn you all your hatred now on me? Did York's dread curse prevail so much
with heaven that Henry's death, my lovely Edward's death, their kingdom's loss,
my woful banishment, should all but answer for that peevish brat?
Can curses pierce the clouds and enter heaven? 1234

60 a 30 A—3 lb. 8-POINT GOTHIC CONDENSED, No. 241. \$2.70.

WHY, THEN GIVE WAY, YOU DULL CLOUDS, TO MY QUICK CURSES!
Though not by war, by surfeit die your king, as ours by murder, to make him a
king! Edward, thy son, that now is prince of Wales, for Edward,
our son, that was prince of Wales, die in his youth 1234

40 a 20 A—3 lb. 6 oz. 10-POINT GOTHIC CONDENSED, No. 241. \$2.50.

BY LIKE UNTIMELY VIOLENCE! THYSELF A QUEEN, FOR
Me that was a queen, outlive thy glory, like my wretched self!
Long may'st thou live, to wail thy children's death
and see another, as I see thee now, 1234

30 a 15 A—3 lb. 4 oz. 12-POINT GOTHIC CONDENSED, No. 241. \$2.15.

DECK'D IN THY RIGHTS, AS THOU ART STALL'D IN
Mine! Long die thy happy days before thy death, and,
after many lengthen'd hours of grief, die neither
mother, wife, nor England's queen! 1234

25 a 12 A—5 lb. 8 oz. 18-POINT GOTHIC CONDENSED, No. 241. \$3.30.

RIVERS, AND DORSET, YOU BOTH WERE
Standers by, and so wast thou, Lord Hastings,
when my son was stabbed with bloody
daggers: God, I pray him, 1234

V. B. MUNSON, SUCCESSOR TO
GEO. BRUCE'S SON & CO., 13 CHAMBERS STREET, NEW YORK.

STYLE 241.

25 a 12 A—7 lb. 8 oz. 22-POINT GOTHIC CONDENSED, No. 241.

\$4.20.

THAT NONE OF YOU MAY LIVE
Your natural age, but by some unlook'd
accident cut off! And I shall
never cease to pray. 123

20 a 10 A—9 lb. 4 oz. 28-POINT GOTHIC CONDENSED, No. 241.

\$5.20.

POOR OLD PAINTED QUEEN,
Vain flourish of my fortune! Why
strew'st thou sugar on that
bottled up spider, 123

15 a 8 A—12 lb. 4 oz. 36-POINT GOTHIC CONDENSED, No. 241.

\$6.85.

WHOSE DEADLY WEB
Ensnareth thee? 'Tis knife
thou whet'st for thyself 12

V. B. MUNSON, SUCCESSOR TO
GEO. BRUCE'S SON & CO., 13 CHAMBERS STREET, NEW YORK.

STYLE 242.

30 A—1 lb. 6 oz.

8-POINT GOTHIC CONDENSED, No. 242.

\$1.25.

AND LEAVE OUT THEE? STAY, DOG, FOR THOU SHALT HEAR ME. IF HEAVEN HAVE
ANY GRIEVOUS PLAGUE IN STORE, EXCEEDING THOSE THAT I CAN WISH UPON
THEE, O, LET THEM KEEP IT TILL THY SINS BE RIPE, AND THEN 1234

20 A—1 lb. 6 oz.

10-POINT GOTHIC CONDENSED, No. 242.

\$1.00.

HURL DOWN THEIR INDIGNATION ON THEE, THE TROUBLER OF THE POOR
WORLD'S PEACE! THE WORM OF CONSCIENCE STILL BE-GNAW
THY SOUL! THY FRIENDS SUSPECT FOR TRAITORS 1234

15 A—1 lb. 8 oz.

12-POINT GOTHIC CONDENSED, No. 242.

\$1.00.

WHILE THOU LIV'ST, AND TAKE DEEP TRAITORS FOR THY
DEAREST FRIENDS! NO SLEEP CLOSE UP THAT
DEADLY EYE OF THINE, UNLESS IT 1234

15 A—2 lb. 8 oz.

16-POINT GOTHIC CONDENSED, No. 242.

\$1.50.

BE WHILE A TORMENTING DREAM AFFRIGHTS
THEE WITH A HELL OF UGLY DEVILS!
THOU ELVISH-MARKED 1234

25 a 12 A—6 lb. 6 oz.

20-POINT GOTHIC CONDENSED, No. 242.

\$3.80.

WERE I SO TALL TO REACH THE
Pole, or grasp the ocean in my span, I would
be measured by my soul: the mind's
the standard of the man 123

V. B. MUNSON, SUCCESSOR TO
GEO. BURCE'S SON & CO., 13 CHAMBERS STREET, NEW YORK.

STYLE 242.

20 a 10 A—8 lb. 10 oz. 24-POINT GOTHIC CONDENSED, No. 242.

\$4.85.

**FALSE-BODING WOMAN,
End thy frantic curse, lest to 12**

15 a 8 A—14 lb. 36-POINT GOTHIC CONDENSED, No. 242.

\$7.85.

**THY HARM THOU
Move our patience 12**

5 a 5 A—12 lb. 6 oz. 48-POINT GOTHIC CONDENSED, No. 242.

\$6.70.

**FOUL SHAME
Upon you, fiend 2**

5 a 5 A—36 lb. 8 oz. 72-POINT GOTHIC CONDENSED, No. 242.

\$19.00.

The Bard 3

V. B. MUNSON, SUCCESSOR TO
GEO. BRUCE'S SON & CO., 13 CHAMBERS STREET, NEW YORK.

STYLE 243.

30 A—10 oz. 5-POINT GOTHIC CONDENSED, No. 243. \$1.15.

**MY LORD OF BLOSTER, I HAVE TOO LONG BORNE YOUR BLUNT UPBRAIDINGS AND YOUR BITTER SCOFFS; BY HEAVEN,
I WILL ACQUAINT HIS MAJESTY OF THESE GROSS TAUNTS THAT OFT I HAVE ENDUR'D. I HAD RATHER
BE A COUNTRY SERVANT-MAID THAN A GREAT QUEEN, WITH THIS CONDITION, 1234567890**

30 A—1 lb. 6-POINT GOTHIC CONDENSED, No. 243. \$1.15.

**TO BE SO BAITED, AND SCORN'D, AND STORMED AT; SMALL JOY HAVE I IN BEING ENGLAND'S
QUEEN. AND LESSEN'D BE THAT SMALL, GOD, I BESEECH HIM! THY HONOUR,
STATE, AND SEAT, IS DUE TO ME. 1234567890**

30 A—1 lb. 12 oz. 8-POINT GOTHIC CONDENSED, No. 243. \$1.55.

**THREAT ME WITH TELLING OF THE KING? TELL HIM, AND SPARE NOT;
WHAT I HAVE SAID I WILL AVOUCH, IN PRESENCE OF THE
KING. I DARE ADVENTURE TO BE SENT 12345**

20 A—1 lb. 12 oz. 10-POINT GOTHIC CONDENSED, No. 243. \$1.30.

**TO THE TOWER. 'TIS TIME TO SPEAK, ALL MY PAINS ARE
QUITE FORGOT. OUT, DEVIL! I REMEMBER THEM
TOO WELL; THOU KILL'DST MY HUSBAND 123**

15 A—1 lb. 12 oz. 12-POINT GOTHIC CONDENSED, No. 243. \$1.15.

**HENRY IN THE TOWER, AND EDWARD, MY POOR SON,
AT TEWKSBURY, WHICH MAY GOD REVENGE,
YOU MURTHEROUS VILLAIN 1234**

12 A—2 lb. 14 oz. 18-POINT GOTHIC CONDENSED, No. 243. \$1.75.

**HIE THEE TO HELL FOR SHAME, AND
LEAVE THIS WORLD, CACODÆMON!
THERE THY KINGDOM IS 1234**

V. B. MUNSON, SUCCESSOR TO
GEO. BRUCE'S SON & CO., 13 CHAMBERS STREET, NEW YORK.

STYLE 243.

10 A—4 lb. 6 oz.

24-POINT GOTHIC CONDENSED, No. 243.

\$2.45.

**PEACE, MASTER MARQUIS!
YOU ARE MALAPERT; YOU
TALK TOO MUCH 1234**

8 A—7 lb. 8 oz.

36-POINT GOTHIC CONDENSED, No. 243.

\$4.20.

**TUT, TUT, MY LORD,
WE'LL HAVE NONE
OF THY PRATE 2**

5 A—8 lb. 12 oz.

48-POINT GOTHIC CONDENSED, No. 243.

\$4.75.

**COME, HE DIES;
I HAD FORGOT
REWARD 12**

V. B. MUNSON, SUCCESSOR TO
GEO. BRUCE'S SON & CO., 13 CHAMBERS STREET, NEW YORK.

STYLE 244.

30 A—12 oz. 6-POINT GOTHIC CONDENSED, No. 244. \$0.90.

A LITTLE JOY ENJOYS THE QUEEN THEREOF! FOR I AM SHE, AND ALTOGETHER JOYLESS. I CAN NO LONGER
HOLD ME PATIENT. HEAR ME, YOU WRANGLING PIRATES, THAT FALL OUT 1234567890

30 A—1 lb. 4 oz. 8-POINT GOTHIC CONDENSED, No. 244. \$1.15.

IN SHARING THAT WHICH YOU HAVE PILL'D FROM ME; WHICH OF YOU TREMBLES NOT
THAT LOOKS ON ME? IF NOT, THAT I BEING QUEEN YOU 1234567890

20 A—1 lb. 6 oz. 10-POINT GOTHIC CONDENSED, No. 244. \$1.00.

BOW LIKE SUBJECTS, YET THAT BY YOU DEPOS'D YOU DO QUAKE LIKE
REBELS? AH, GENTLE VILLAIN, DO NOT TURN AWAY! 1234

15 A—1 lb. 8 oz. 12-POINT GOTHIC CONDENSED, No. 244. \$1.00.

FOUL WRINKLED WITCH, WHAT MAK'ST THOU IN MY SIGHT?
BUT REPETITION OF WHAT THOU HAST MARR'D; 123

15 A—2 lb. 4 oz. 16-POINT GOTHIC CONDENSED, No. 244. \$1.35.

THAT I WILL MAKE, SIR, BEFORE I LET THEE GO.
I SEE YOU ARE BECOMING PENITENT. 123

12 A—3 lb. 2 oz. 20-POINT GOTHIC CONDENSED, No. 244. \$1.90.

THAT SHALT THOU KNOW HEREAFTER 12

10 A—4 lb. 2 oz. 24-POINT GOTHIC CONDENSED, No. 244. \$2.30.

GIVE YOU GOOD MORROW 12

8 A—6 lb. 12 oz. 36-POINT GOTHIC CONDENSED, No. 244. \$3.80.

MADAM, FAREWELL 2

V. B. MUNSON, SUCCESSOR TO
GEO. BRUCE'S SON & CO., 13 CHAMBERS STREET, NEW YORK.

STYLE 620.

30 a 15 A
1 lb. 14 oz.

12-POINT GOTHIC EXTRA CONDENSED, No. 620.

\$2.20.

IF BY YOUR ART, MY DEAREST FATHER, YOU HAVE PUT THE WILD WATERS IN THIS ROAR,
Alay them; the sky, it seems, would pour down stinking pitch, but that the sea, mounting to the welkin's
check, dashes the fire out. O, I have suffered with those that I saw suffer! a brave
vessel, who had no doubt some noble creature in her, 1234567890

25 a 12 A
3 lb. 2 oz.

18-POINT GOTHIC EXTRA CONDENSED, No. 620.

\$3.10.

DASH'D ALL TO PIECES. O, THE CRY DID KNOCK AGAINST MY
Very heart! Poor souls! they perish'd. Had I been any god of power, I
would have sunk the sea within the earth, or 1234567890

20 a 10 A
4 lb. 2 oz.

24-POINT GOTHIC EXTRA CONDENSED, No. 620.

\$3.70.

E'ER IT SHOULD THE GOOD SHIP HAVE SWALLOW'D,
And the fraughting souls within her. Now I pray your reason
for raising this terrible sea-storm. 1234567890

15 a 8 A
7 lb.

36-POINT GOTHIC EXTRA CONDENSED, No. 620.

\$5.75.

GOOD! SPEAK TO THE MARINERS!
Fall to't, or we run ourselves aground. 1234

12 a 7 A
11 lb. 14 oz.

48-POINT GOTHIC EXTRA CONDENSED, No. 620.

\$8.55.

BOATSWAIN, have a care 12345

V. B. MUNSON, SUCCESSOR TO
GEO. BRUCE'S SON & CO., 13 CHAMBERS STREET, NEW YORK.

STYLE 621.

30 A—8 oz. 5-POINT GOTHIC CONDENSED HAIR LINE, No. 621. \$1.40.

NIBLE PATRIOTISM, PATRONS OF MY RIGHT, DEFEND THE JUSTICE OF MY CAUSE WITH ARMS: AND, COUNTRYMEN, MY LOVING
FOLLOWERS, PLEAD MY SUCCESSIONAL TITLE WITH YOUR SWORDS. I AM HIS FIRST-BORN SON, THAT WAS THE LAST
THAT WORE THE IMPERIAL CROWN OF ROME; THEN LET MY FATHER'S HONORS LIVE IN ME
OUR WRONGS MAKE ADE WITH THIS INDIGNITY 1234567890

30 A—12 oz. 6-POINT GOTHIC CONDENSED HAIR LINE, No. 621. \$1.50.

ROMANS, FRIENDS, FOLLOWERS, FAVOURERS OF MY RIGHT, IF EVER BASSIANUS, CÆSAR'S SON, WERE CRACIOUS IN
THE EYES OF ROYAL ROME, KEEP THEN THIS PASSAGE TO THE CAPITOL; AND SUFFER NOT DISHONOR
TO APPROACH TH' IMPERIAL SEAT; TO VIRTUE CONSECRATE, TO JUSTICE, CONTINENCE,
AND NOBILITY: BUT LET DESERT IN PURE ELECTION SHINE. 123456

30 A—1 lb. 4 oz. 8-POINT GOTHIC CONDENSED HAIR LINE, No. 621. \$2.00.

PRINCES, THAT STRIVE BY FACTIONS AND BY FRIENDS AMBITIOUSLY FOR RULE AND
EMPERY, KNOW THAT THE PEOPLE OF ROME, FOR WHOM WE STAND FRIENDS
A SPECIAL PARTY, HAVE BY COMMON VOICE, IN ELECTION FOR THE
ROMAN EMPEROR, CHOSEN ANDRONICUS, SURNAMED 1234

20 A—1 lb. 8 oz. 10-POINT GOTHIC CONDENSED HAIR LINE, No. 621. \$1.95.

PIUS, FOR MANY GOOD AND GREAT DESERTS TO ROME: A NOBLER
MAN, A BRAVER WARRIOR, LIVES NOT TO-DAY WITHIN THE
CITY'S WALLS. HE BY THE SENATE IS ACCITED
HOME FROM WEARY WARS AGAINST 123

15 A—1 lb. 8 oz. 12-POINT GOTHIC CONDENSED HAIR LINE, No. 621. \$1.75.

THE BARBAROUS GOths, THAT WITH HIS SONS, A TERROR
TO OUR FOES, HATH YOK'D A NATION STRONG,
TRAIN'D UP IN ARMS, AND EVER READY
FOR THE FRAY. 1234567890

V. B. MUNSON, SUCCESSOR TO
GEO. BRUCE'S SON & CO., 13 CHAMBERS STREET, NEW YORK.

STYLE 250.

30 a 30 A—2 B. 6-POINT GOTHIC EXTENDED, No. 250. \$2.30.

VANISH; OR I SHALL GIVE THEE THY DESERVING.

Let him take thee, and hoist thee up to the shouting plebeians; follow
his chariot, like the greatest spot of all thy sex; 1234

30 a 30 A—3 B. 4 oz. 8-POINT GOTHIC EXTENDED, No. 250. \$2.95.

'TIS WELL THOU'RT GONE, IF IT BE WELL

To live; but better 'twere thou fell'st into my fury, for one
death might have prevented many 12345

20 a 20 A—3 B. 6 oz. 10-POINT GOTHIC EXTENDED, No. 250. \$2.50.

I HAVE DONE MY WORK ILL, FRIENDS:

Pray make an end of what I have begun 1234

15 a 15 A—3 B. 12 oz. 12-POINT GOTHIC EXTENDED, No. 250. \$2.50.

THE STAR IS FALLEN, AND

Time is at his period. Alas, wow! 1234

12 a 12 A—6 B. 6 oz. 18-POINT GOTHIC EXTENDED, No. 250. \$3.80.

BEAR ME, FRIENDS,

To where Cleopatra is 123

10 a 10 A—10 B. 2 oz. 24-POINT GOTHIC EXTENDED, No. 250. \$5.70.

WHERE, Antony 12

8 a 8 A—16 B. 6 oz. 36-POINT GOTHIC EXTENDED, No. 250. \$9.15.

CLEOpatra 12

5 a 5 A—17 B. 12 oz. 48-POINT GOTHIC EXTENDED, No. 250. \$9.60.

ANTony 12

V. B. MUNSON, SUCCESSOR TO
GEO. BRUCE'S SON & CO., 13 CHAMBERS STREET, NEW YORK.

STYLE 251.

15 a 15 A—3 lb. 8 oz. 12-POINT GOTHIC EXTENDED, No. 251. \$2.30.

THE TROOPERS FELL BACK
On two sides, and the carriages, with
the President's leading 123

12 a 12 A—5 lb. 4 oz. 18-POINT GOTHIC EXTENDED, No. 251. \$3.15.

FILED SLOWLY PAST
As the massed bands played
Annie Rooney and 123

10 a 10 A—8 lb. 24-POINT GOTHIC EXTENDED, No. 251. \$4.50

OTHER CLASSIC
Selections, to the 12

8 a 8 A—12 lb. 36-POINT GOTHIC EXTENDED, No. 251. \$6.70.

MANIFEST
Delight of all 2

5 a 5 A—13 lb. 8 oz. 48-POINT GOTHIC EXTENDED, No. 251. \$7.30.

MARTIAL
Tramping 4

V. B. MUNSON, SUCCESSOR TO
GEO. BRUCE'S SON & CO., 13 CHAMBERS STREET, NEW YORK.

STYLE 260.

60 a 30 A
3 lb. 8 oz.

8-POINT GOTHIC CONDENSED ITALIC, No. 260.

\$3.15.

*O, PARDON ME, THOU BLEEDING PIECE OF EARTH, THAT I AM
Meek and gentle with these butchers! Thou art the ruins of the noblest man
that ever lived in the tide of times. Woe to the hand that
shed this costly blood. Over thy wounds 1234*

40 a 20 A
3 lb. 8 oz.

10-POINT GOTHIC CONDENSED ITALIC, No. 260.

\$2.60.

*NOW DO I PROPHECY, WHICH, LIKE DUMB MOUTHS,
Do ope their ruby lips to beg the voice and utterance of my tongue,
a curse shall light upon the limbs of men; domestic
fury, and fierce civil strife, 12345*

30 a 15 A
4 lb.

12-POINT GOTHIC CONDENSED ITALIC, No. 260.

\$2.65.

*SHALL CUMBER ALL THE PARTS OF ITALY;
Blood and destruction shall be so in use, and dreadful
objects so familiar, that mothers shall but
smile when they behold 2468*

30 a 15 A
5 lb. 12 oz.

16-POINT GOTHIC CONDENSED ITALIC, No. 260.

\$3.45.

*THEIR INFANTS QUARTER'D WITH
The hands of war; all pity chok'd with custom
of fell deeds; and Cæsar's spirit,
ranging for revenge, 123*

25 a 12 A
7 lb. 10 oz.

20-POINT GOTHIC CONDENSED ITALIC, No. 260.

\$4.60.

*WITH ATE BY HIS SIDE, COME
Hot from hell, shall in these confines,
with a monarch's voice, 1234*

V. B. MUNSON, SUCCESSOR TO
GEO. BRUCE'S SON & CO., 13 CHAMBERS STREET, NEW YORK.

STYLE 261.

5 A—11 lb. 4 oz.

48-POINT GOTHIC CONDENSED ITALIC, No. 261.

\$6.10.

***AMBASSADOR
TO SWAT
1234567890***

5 A—20 lb. 4 oz.

72-POINT GOTHIC CONDENSED ITALIC, No. 261.

\$10.55

***BOSANKO
VALE 2***

V. B. MUNSON, SUCCESSOR TO
GEO. BRUCE'S SON & CO., 13 CHAMBERS STREET, NEW YORK.

STYLE 300.

60 a 30 A—3 lb. 14 oz. 8-POINT ANTIQUE, No. 300. \$3.50.

ROMANS, COUNTRYMEN, AND LOVERS, HEAR ME
For my cause; be silent, that you may hear; believe me for mine
honour, and have respect to mine honour, 1234

40 a 20 A—4 lb. 2 oz. 10-POINT ANTIQUE, No. 300. \$3.05.

THAT YOU MAY BELIEVE; CENSURE ME
In your wisdom; and awake your senses, that you
may the better judge. If there 1234

30 a 15 A—4 lb. 6 oz. 12-POINT ANTIQUE, No. 300. \$2.90.

BE ANY IN THIS ASSEMBLY, ANY
Dear friend of Cæsar's, to him I say, Brutus'
love to Cæsar was no less than his. 12

25 a 12 A—7 lb. 12 oz. 18-POINT ANTIQUE, No. 300. \$4.65.

IF THEN THAT FRIEND
Why I rose against Cæsar, 123

20 a 10 A—11 lb. 12 oz. 24-POINT ANTIQUE, No. 300. \$6.60.

THIS I ANSWER:
Not that I loved him 3

15 a 8 A—20 lb. 36-POINT ANTIQUE, No. 300. \$11.20.

LESS, but that 5

5 a 5 A—16 lb. 14 oz. 48-POINT ANTIQUE, No. 300. \$9.10.

ROMans! 4

V. B. MUNSON, SUCCESSOR TO
GEO. BRUCE'S SON & CO., 13 CHAMBERS STREET, NEW YORK.

STYLE 301.

60 a 30 A—1 lb. 14 oz.

5½-POINT ANTIQUE, No. 301.

\$2.70.

NOT THAT I LOVED CÆSAR LESS, BUT THAT I LOVED OLD ROME MORE.
Had you rather Cæsar were living, and die all slaves, than that Cæsar were dead, to live all free men? As Cæsar loved me, I weep for him; as he was fortunate, I rejoice at it; as he was vallant, I honour him: but, as he was ambitious, I slew him. 1234567890

60 a 30 A—2 lb. 10 oz.

6-POINT ANTIQUE, No. 301.

\$3.05.

THERE IS TEARS, FOR HIS LOVE; JOY, FOR HIS FORTUNE;
Honour, for his valour; and death, for his ambition. Who is here so base as to be a bondman? If any, speak; for him have I offended.
Who is here so rude that would not 1234

60 a 30 A—4 lb. 4 oz.

8-POINT ANTIQUE, No. 301.

\$3.85.

BE A ROMAN? IF ANY, SPEAK; FOR HIM HAVE I
Offended. Who is here so vile that will not love his country? If any, speak; for him have I offended. I pause for a reply.
None, Brutus. Then none have I offended. 123

40 a 20 A—3 lb. 12 oz.

10-POINT ANTIQUE, No. 301.

\$2.75.

I HAVE DONE NO MORE TO CÆSAR THAN
You shall do to Brutus. The question of Cæsar's death is writ in the Capitol; his glory not extenuated, wherein he was worthy; nor 1234

30 a 15 A—4 lb. 6 oz.

12-POINT ANTIQUE, No. 301.

\$2.90.

HIS OFFENCES ENFORC'D, FOR
Which he suffer'd death. Here comes his body, mourned by Mark Antony, 1234

25 a 12 A—7 lb. 10 oz.

18-POINT ANTIQUE, No. 301.

\$4.60.

I SLEW MY BEST LOVER
For the good of Rome, so I have same dagger for myself. 12

V. B. MUNSON, SUCCESSOR TO
GEO. BRUCE'S SON & CO., 13 CHAMBERS STREET, NEW YORK.

STYLE 301:

25 a 12 A—11 lb. 14 oz.

22-POINT ANTIQUE, No. 301.

\$6.65.

LIVE, BRUTUS, LIVE!
Bring him with triumph to
his house; give him a
statue with his 12

20 a 10 A—17 lb. 8 oz.

28-POINT ANTIQUE, No. 301.

\$9.80.

ANCESTORS.
Cæsar's better part
crown'd in 12

15 a 8 A—20 lb. 6 oz.

36-POINT ANTIQUE, No. 301.

\$11.40.

BRUTUS!
Silence, silence!
he speaks 12

V. B. MUNSON, SUCCESSOR TO
GEO. BRUCE'S SON & CO., 13 CHAMBERS STREET, NEW YORK.

STYLE 302.

60 a 30 A—1 lb. 12 oz. 5-POINT ANTIQUE, No. 302. \$3.15.

IF NOT THE FACE OF MEN, THE SUFFERANCE OF OUR SOULS, THE TIME'S
Abuse: if these motives be weak, break off betimes, and every man hence to his idle bed; so let
high-sighted tyranny range on, till each man drop by lottery. But if these,
as I am sure they do, bear fire enough to kindle cowards, 1245

60 a 30 A—2 lb. 10 oz. 6-POINT ANTIQUE, No. 302. \$3.05.

AND TO STEEL WITH VALOUR THE MELTING SPIRITS OF
Women, then, countrymen, what need we any spur but our own cause to prick us
to redress? what other bond than secret Romans, that have
spoke the word, and will not palter? 12345

60 a 30 A—3 lb. 12 oz. 8-POINT ANTIQUE, No. 302. \$3.40.

AND WHAT OTHER OATH THAN HONESTY TO HONESTY
Engag'd, that this shall be, or we will fall for it? Swear priests, and
cowards, and men cautelous, old feeble carrions, and such
suffering souls that welcome wrongs: Unto 123

40 a 20 A—4 lb. 10-POINT ANTIQUE, No. 302. \$2.95.

BAD CAUSES SWEAR SUCH CREATURES
As men doubt; but do not stain the even virtue of our
enterprise, nor the insuppressive 1234

30 a 15 A—4 lb. 10 oz. 12-POINT ANTIQUE, No. 302. \$3.05.

METAL OF OUR SPIRITS, TO THINK
That, or our cause, or our performance, did
need a single oath, when 1234

25 a 12 A—7 lb. 12 oz. 18-POINT ANTIQUE, No. 302. \$4.65.

EVERY DROP OF BLOOD
That every Roman subject bears,
and nobly bears, 1234

V. B. MUNSON, SUCCESSOR TO
GEO. BRUCE'S SON & CO., 13 CHAMBERS STREET, NEW YORK.

STYLE 302.

25 a 12 A—11 lb.

22-POINT ANTIQUE, No. 302.

\$6.15.

**WHAT OF CICERO?
Shall we sound him too? 12**

20 a 10 A—14 lb.

28-POINT ANTIQUE, No. 302.

\$7.85.

**NAME HIM NOT
Indeed, he is not fit 12**

15 a 8 A—17 lb. 6 oz.

36-POINT ANTIQUE, No. 302.

\$9.75.

**TREBONIUS
Is welcome here 12**

5 a 5 A—19 lb. 12 oz.

48-POINT ANTIQUE, No. 302.

\$10.65.

ASHing 13

4 A—31 lb. 8 oz.

84-POINT ANTIQUE, No. 302.

\$15.75.

TON 7

V. B. MUNSON, SUCCESSOR TO
GEO. BRUCE'S SON & CO., 13 CHAMBERS STREET, NEW YORK.

STYLE 303.

60 a 30 A—2 lb. 10 oz.

6-POINT DORIC, No. 303.

\$3.05.

**OUR COURSE WILL SEEM TOO BLOODY, CAIUS CASSIUS,
To cut the head off, and then hack the limbs, like wrath in death and envy
afterwards: for Antony is but a limb of Cæsar. 12345**

60 a 30 A—4 lb. 2 oz.

8-POINT DORIC, No. 303.

\$3.70.

**LET US BE SACRIFICERS, BUT NOT BUTCHERS, CAIUS.
We all stand up against the spirit of Cæsar; and in the spirit
of men there is no blood; O, that we then 1234**

40 a 20 A—4 lb. 14 oz.

10-POINT DORIC, No. 303.

\$3.60.

**COULD COME BY CÆSAR'S SPIRIT, AND
Not dismember Cæsar! But, alas, Cæsar must
bleed for it! And, gentle friends, 123**

30 a 15 A—6 lb. 2 oz.

12-POINT DORIC, No. 303.

\$4.05.

**LET'S KILL HIM BOLDLY, BUT
Not wrathfully; let's carve him as
a dish fit for the gods, 123**

25 a 12 A—9 lb. 10 oz.

18-POINT DORIC, No. 303.

\$5.80.

**NOT HEW HIM AS A
Carcase fit for hounds. 12**

20 a 10 A—15 lb. 8 oz.

24-POINT DORIC, No. 303.

\$8.70.

ALL HAIL, Cæsar 2

15 a 8 A—23 lb. 8 oz.

36-POINT DORIC, No. 303.

\$13.15.

CALPurnia 2

V. B. MUNSON, SUCCESSOR TO
GEO. BRUCE'S SON & CO., 13 CHAMBERS STREET, NEW YORK.

STYLE 304.

60 a 30 A—2 B. 8 oz. 6-POINT ANTIQUE, No. 304. \$2.90.

O MIGHTY CAESAR! DOST THOU LIE SO LOW? ARE ALL THY
Conquests, glories, triumphs, spoils, shrunk to this little measure? Fare thee
well. I knew not, gentlemen, what you intend, who else must
be let blood, who else is rank: 1234567890

60 a 30 A—4 B. 4 oz. 8-POINT ANTIQUE, No. 304. \$3.85.

IF I MYSELF, THERE IS NO HOUR SO FIT AS
Caesar's death hour, nor no instrument of half that worth as those
your swords, made rich with the most noble blood
of all this world. I do beseech ye, 123

40 a 20 A—3 B. 4 oz. 9-POINT ANTIQUE, No. 304. \$2.60.

IF YOU BEAR ME HARD, NOW, WHILST YOUR
Purpled hands do reek and smoke, fulfil your pleasure. Were I
to live a thousand years I shall not find myself so apt
to die: No place will please me so, 123

40 a 20 A—4 B. 8 oz. 10-POINT ANTIQUE, No. 304. \$3.35.

NO MEAN OF DEATH, AS HERE BY
Caesar, and by you so cut off, the choice and master
spirits of this age. O Antony! beg not
your death of us. Though 123

40 a 20 A—4 B. 12 oz. 11-POINT ANTIQUE, No. 304. \$3.35.

NOW WE MUST APPEAR BLOODY
And cruel, as, by our hands and this our present act,
you see we do, yet see you but our
hands, and this the 123

30 a 15 A—5 B. 6 oz. 12-POINT ANTIQUE, No. 304. \$3.50.

BLEEDING BUSINESS THEY
Have done: our hearts you see not, and
our hearts are pitiful 123

V. B. MUNSON, SUCCESSOR TO
GEO. BRUCE'S SON & CO., 13 CHAMBERS STREET, NEW YORK.

STYLES 305 AND 306.

60 a 30 A—2 lb. 8 oz.

6-POINT ANTIQUE, No. 305.

\$2.90.

EACH MAN RENDER ME HIS BLOODY HAND: FIRST, MARCUS BRUTUS,
Will I shake with you; next, Caius Cassius, do I take your hand; and now, Decius
Brutus, yours; now yours, Metullus; yours, Cinna; and, my valiant
Casca, yours; though last not least, Trebonius. 12345

60 a 30 A—2 lb. 2 oz.

6-POINT ANTIQUE, No. 306.

\$2.45.

GENTLEMEN ALL, ALAS! WHAT SHALL I SAY? MY CREDIT NOW STANDS
On such slippery ground that one of two bad ways you must conceit me, either a coward or a
flatterer. That I did love thee, Cæsar, O, 'tis true: if then thy spirit look upon
us now, shall it not grieve thee, dearer than thy death, 1234

60 a 30 A—3 lb. 10 oz.

8-POINT ANTIQUE, No. 306.

\$3.25.

TO SEE THY ANTONY MAKING HIS PEACE, SHAKING
The bloody fingers of thy foes, most noble! in the presence of thy corse?
Had I as many eyes as thou hast wounds, weeping 1234

40 a 20 A—3 lb. 12 oz.

10-POINT ANTIQUE, No. 306.

\$2.80.

FAST AS THEY STREAM FORTH THY BLOOD,
It would become me better than to close in friendly terms
with thine enemies. Pardon me, Julius! 12345

30 a 15 A—4 lb. 8 oz.

12-POINT ANTIQUE, No. 306.

\$3.00.

HERE WAST THOU BAY'D, BRAVE
Hart; here didst thou fall, and here thy hunters
stand, sign'd in thy spoil, and 1234

25 a 12 A—7 lb. 12 oz.

18-POINT ANTIQUE, No. 306.

\$4.65.

CRIMSON'D I' THY LETHE.
O world! thou wast the forest to
this hart, and this 1234

V. B. MUNSON, SUCCESSOR TO
GEO. BRUCE'S SON & CO., 13 CHAMBERS STREET, NEW YORK.

STYLE 307.

25 a 12 A—8 lb. 8 oz.

18-POINT ANTIQUE, No. 307.

\$5.10.

**SMOOTH SUCCESS BE
Strew'd beneath your feet 12**

25 a 12 A—9 lb.

20-POINT ANTIQUE, No. 307.

\$5.40.

**FISHES, DRINKS, AND
Wastes his nights in revel 12**

25 a 12 A—13 lb. 4 oz.

22-POINT ANTIQUE, No. 307.

\$7.40.

ANTONY Cleopatra 12

20 a 10 A—11 lb. 12 oz.

24-POINT ANTIQUE, No. 307.

\$6.60.

DRIVE him to Rome 12

15 a 8 A—24 lb. 14 oz.

36-POINT ANTIQUE, No. 307.

\$13.90.

CHArmian 2

15 a 8 A—26 lb. 8 oz.

40-POINT ANTIQUE, No. 307.

\$14.30.

OCTAvius 2

WE ALSO MAKE 48 AND 72-POINT OF THIS SERIES.

V. B. MUNSON, SUCCESSOR TO
GEO. BRUCE'S SON & CO., 13 CHAMBERS STREET, NEW YORK.

STYLE 308.

60 a 30 A—2 lb. 12 oz. 6-POINT ITALIAN ANTIQUE, No. 308. \$3.20.

THUS, BRUTUS, DID MY MASTER BID ME KNEEL; THUS
Did Mark Antony bid me fall down; and, being prostrate, thus he bade
me say: Brutus is noble, wise, valiant and honest: 12345

60 a 30 A—4 lb. 6 oz. 8-POINT ITALIAN ANTIQUE, No. 308. \$3.95.

I WILL FOLLOW THE FORTUNES AND AFFAIRS
Of noble Brutus, through the hazards of this untrod state, with
all true faith. So says my master Antony. 1234

40 a 20 A—4 lb. 6 oz. 10-POINT ITALIAN ANTIQUE, No. 308. \$3.25.

THY MASTER IS A WISE AND VALIANT
Roman; I never thought him worse. Tell him, so
please him, come unto this place; 123

30 a 15 A—5 lb. 6 oz. 12-POINT ITALIAN ANTIQUE, No. 308. \$3.55.

HE SHALL BE SATISFIED,
And, by my honour, go unharm'd 123

25 a 12 A—8 lb. 10 oz. 18-POINT ITALIAN ANTIQUE, No. 308. \$5.20.

UPON HIS devious way 12

20 a 10 A—13 lb. 8 oz. 24-POINT ITALIAN ANTIQUE, No. 308. \$7.55.

MOST barbarous 12

15 a 8 A—22 lb. 4 oz. 36-POINT ITALIAN ANTIQUE, No. 308. \$12.45.

KING Lear 12

5 a 5 A—19 lb. 12 oz. 48-POINT ITALIAN ANTIQUE, No. 308. \$10.65.

MU Tiny 2

V. B. MUNSON, SUCCESSOR TO
GEO. BRUCE'S SON & CO., 13 CHAMBERS STREET, NEW YORK.

STYLE 309.

30 a 15 A—6 lb. 4 oz. 12-POINT ANTIQUE POINTED, No. 309.

\$4.10.

WHEREFORE TO DOVER?

**Because I would not see thy cruel
nails pluck out his eyes 12**

25 a 12 A—10 lb. 4 oz. 18-POINT ANTIQUE POINTED, No. 309.

\$6.15.

THRUST HIM OUT

**At gates, and let him smell
his way to Dover 12**

25 a 12 A—13 lb. 12 oz. 22-POINT ANTIQUE POINTED, No. 309.

\$7.70.

IT WAS HE THAT

**To us made overture of
thy treasons 12**

20 a 10 A—16 lb. 6 oz. 28-POINT ANTIQUE POINTED, No. 309.

\$9.15.

O, I AM SLAIN!

**My lord, you've one
eye left 123**

V. B. MUNSON, SUCCESSOR TO
GEO. BRUCE'S SON & CO., 13 CHAMBERS STREET, NEW YORK.

STYLE 310.

60 a 30 A—2 lb. 4 oz. 6-POINT ANTIQUE, No. 310. \$2.60.

**THERE IS A KIND OF CHARACTER IN THY LIFE THAT, TO THE
Observer, doth thy history fully unfold: thyself and thy belongings are not thine own so
proper as to waste thyself upon thy virtues, they on thee. 1234567890**

60 a 30 A—3 lb. 10 oz. 8-POINT ANTIQUE, No. 310. \$3.25.

**HEAVEN DOES WITH US AS WE WITH TORCHES DO;
Not light them for themselves: for if our virtues did not go forth of us, 'twere
all alike as if we had them not. Spirits are not finely 1234**

40 a 20 A—3 lb. 12 oz. 10-POINT ANTIQUE, No. 310. \$2.80.

**TOUCH'D BUT TO FIND ISSUES: NOR NATURE
Never lends the smallest scruple of her excellence, but, like a
thrifty goddess, she determines herself the 1234**

30 a 15 A—4 lb. 12-POINT ANTIQUE, No. 310. \$2.65.

**GLORY OF A CREDITOR, BOTH THANKS
And use. But I do bend my speech to one that 123**

25 a 12 A—7 lb. 6 oz. 18-POINT ANTIQUE, No. 310. \$4.40.

**CAN MY PART IN HIMSELF
Advertise: hold, therefore, Angelo 12**

25 a 12 A—11 lb. 22-POINT ANTIQUE, No. 310. \$6.15.

MEASURE for measure 123

20 a 10 A—14 lb. 28-POINT ANTIQUE, No. 310. \$7.85.

WHAT'S to do here 12

12 a 6 A—15 lb. 6 oz. 36-POINT ANTIQUE, No. 310. \$8.60.

HE'S ON to-day 3

V. B. MUNSON, SUCCESSOR TO
GEO. BRUCE'S SON & CO., 13 CHAMBERS STREET, NEW YORK.

STYLE 311.

40 a 20 A—4 lb. 12 oz.

10-POINT ANTIQUE, No. 311.

\$3.50.

THEY WERE THE BEST EQUIPPED
And least disciplined corps in the army, and were
seldom seen in the city 1234567890

30 a 15 A—5 lb.

12-POINT ANTIQUE, No. 311.

\$3.30.

WERE A PICTURESQUE BODY
Of blackguards, in their high-topped boots
and silver-tipped sombreros 123

25 a 12 A—8 lb. 8 oz.

18-POINT ANTIQUE, No. 311.

\$5.10.

THE SUN FLASHED ON
The trappings of the soldiers 12

20 a 10 A—12 lb.

24-POINT ANTIQUE, No. 311.

\$6.70.

AND BANNERS
And flags filled the air 12

15 a 8 A—13 lb. 12 oz.

36-POINT ANTIQUE, No. 311.

\$7.70.

RESTLESS
Mobs of people 12

3 a 5 A—16 lb. 8 oz.

48-POINT ANTIQUE, No. 311.

\$8.90.

COLUMbia 2

V. B. MUNSON, SUCCESSOR TO
GEO. BRUCE'S SON & CO., 13 CHAMBERS STREET, NEW YORK.

STYLE 320.

40 a 20 A
3 lb. 2 oz.

10-POINT CLARENDON CONDENSED, No. 320.

\$2.30.

WHEN WE OUR BETTERS SEE BEARING OUR WOES, WE
Scarcely think our miseries our foes. Who alone suffers suffers most in
the mind, leaving free things and happy shows behind;
but then the mind much sufferance doth 1234

30 a 15 A
3 lb. 8 oz.

12-POINT CLARENDON CONDENSED, No. 320.

\$2.30.

O'ERSKIP, WHEN GRIEF HATH MATES, AND
Bearing fellowship. How light and portable my pain is
now, when that which makes me bend
makes the king bow. 12345

30 a 15 A
5 lb. 2 oz.

16-POINT CLARENDON CONDENSED, No. 320.

\$3.10.

EDMUND, FAREWELL. GO, SEEK THE
Traitor Gloster; pinion him like a thief, and bring
him before us: though well we may not
pass upon his life without 1234

25 a 12 A
5 lb. 6 oz.

18-POINT CLARENDON CONDENSED, No. 320.

\$3.25.

THE FORM OF JUSTICE, YET OUR
Power shall do a courtesy to our wrath, which
men may blame, not control. 123

25 a 12 A
8 lb. 2 oz.

22-POINT CLARENDON CONDENSED, No. 320.

\$4.55.

WHO'S THERE? THE TRAITOR?
Ingrateful fox! 'tis he. Bind fast his
corky arms. Hold him. 123

V. B. MUNSON, SUCCESSOR TO
GEO. BRUCE'S SON & CO., 13 CHAMBERS STREET, NEW YORK.

STYLE 320.

20 a 10 A
9 lb. 14 oz.

28-POINT CLARENDON CONDENSED, No. 320.

\$5.50.

WHAT MEAN YOU, SIRRS?
Good my friends, consider: you
are my guests; do me 123

15 a 8 A
10 lb. 14 oz.

36-POINT CLARENDON CONDENSED, No. 320.

\$6.10.

NO FOUL PLAY, MY
Friends. By the gods, 'tis
most ignobly done 12

12 a 7 A
17 lb. 4 oz.

44-POINT CLARENDON CONDENSED, No. 320.

\$9.30.

TO PLUCK ME
By the beard, sir 56

12 a 7 A
22 lb. 2 oz.

48-POINT CLARENDON CONDENSED, No. 320.

\$11.95.

NETHERlands 2

V. B. MUNSON, SUCCESSOR TO
GEO. BRUCE'S SON & CO., 13 CHAMBERS STREET, NEW YORK.

STYLE 321.

60 a 30 A—2 lb. 6-POINT ANTIQUE CONDENSED, No. 321. \$2.30.

WHAT BLOODY MAN IS THAT? HE CAN REPORT, AS SEEMETH BY HIS FLIGHT,
Of the revolt the newest state. This is the sergeant, who, like a good and hardy soldier, fought
'gainst my captivity. Hail, brave friend! Say to the king the knowledge of the
broil, as thou didst leave it. Doubtful it stood, 1234567890

60 a 30 A—3 lb. 6 oz. 8-POINT ANTIQUE CONDENSED, No. 321. \$3.05.

AS TWO SPENT SWIMMERS THAT DO CLING TOGETHER, AND
Choke their art. The merciless Macdonwald (worthy to be a rebel; for, to that,
the multiplying villainies of nature do swarm upon him), 12345

40 a 20 A—3 lb. 4 oz. 10-POINT ANTIQUE CONDENSED, No. 321. \$2.40.

FROM THE ISLES OF KERNES AND GALLOWGLASSES
Is supplied; and fortune, on his quarry smiling, show'd like a rebel's
wife. But all's too weak; for brave Macbeth, 12345

30 a 15 A—3 lb. 10 oz. 12-POINT ANTIQUE CONDENSED, No. 321. \$2.40.

RIGHT WELL HE DESERVES THAT NAME,
Disdaining fortune, with his brandish'd steel, which did
smoke with bloody execution, 12345

25 a 12 A—6 lb. 2 oz. 18-POINT ANTIQUE CONDENSED, No. 321. \$3.70.

LIKE VALOUR'S MINION, CARVED
Out his passage, till he faced the slave; 12

25 a 12 A—8 lb. 4 oz. 22-POINT ANTIQUE CONDENSED, No. 321. \$4.60.

WHICH NE'ER shook hands, nor 12

20 a 10 A—10 lb. 28-POINT ANTIQUE CONDENSED, No. 321. \$5.60.

BADE FAREWELL to him 12

V. B. MUNSON, SUCCESSOR TO
GEO. BRUCE'S SON & CO., 13 CHAMBERS STREET, NEW YORK.

STYLE 321.

15 a 8 A
11 lb. 14 oz.

36-POINT ANTIQUE CONDENSED, No. 321.

\$6.65.

MACBETH and Banquo 12

12 a 7 A
17 lb. 10 oz.

48-POINT ANTIQUE CONDENSED, No. 321 A.

\$9.50.

COME WHAT may 12

5 a 5 A
10 lb. 6 oz.

48-POINT ANTIQUE CONDENSED, No. 321 B.

\$5.60.

GENTLEwoman 12

5 a 5 A
19 lb.

60-POINT ANTIQUE CONDENSED, No. 321.

\$9.90.

Job Printers 6

4 a 4 A
27 lb. 4 oz.

96-POINT ANTIQUE CONDENSED, No. 321.

\$13.60.

New York 2

V. B. MUNSON, SUCCESSOR TO
GEO. BRUCE'S SON & CO., 13 CHAMBERS STREET, NEW YORK.

STYLE 322.

60 a 30 A—2 lb.

6-POINT CLARENDON, No. 322.

\$2.30.

IS THIS A DAGGER WHICH I SEE BEFORE ME, THE HANDLE TOWARD MY HAND ?

Come, let me clutch thee: I have thee not, yet I see thee still. . Art thou not, fatal vision, sensible to feeling, as to sight? or art thou but a dagger of the mind, a false creation, 1234567890

60 a 30 A—2 lb. 14 oz.

8-POINT CLARENDON, No. 322.

\$2.60.

PROCEEDING FROM THE HEAT-OPPRESSED BRAIN ? I SEE THEE YET, IN

Form as palpable as this which now I draw. Thou marshal'st me the way that I was going, and such an instrument I was to use. Mine eyes are 12345

40 a 20 A—3 lb.

10-POINT CLARENDON, No. 322.

\$2.20.

MADE THE FOOLS O' THE OTHER SENSES, ELSE WORTH

All the rest. I see thee still, and on thy blade and dudgeon gouts of blood, which was not so before. There's no such thing. 1234

30 a 15 A—3 lb. 8 oz.

12-POINT CLARENDON, No. 322.

\$2.30.

IT IS THE BLOODY BUSINESS WHICH INFORMS

Thus to mine eyes. Now o'er the one half world nature seems dead, and wicked dreams abuse 1234

25 a 12 A—5 lb. 6 oz.

18-POINT CLARENDON, No. 322.

\$3.25.

THE CURTAIN'D SLEEP: WITCHCRAFT

Celebrates pale Hecate's offerings; wither'd 12

25 a 12 A—8 lb. 14 oz.

22-POINT CLARENDON, No. 322.

\$5.00.

MURTHUR, ALARM'D BY HIS

Sentinel, the wolf, whose howl is 12

20 a 10 A—11 lb. 4 oz.

28-POINT CLARENDON, No. 322.

\$6.30.

HIS WATCH, stealthily 12

V. B. MUNSON, SUCCESSOR TO
GEO. BRUCE'S SON & CO., 13 CHAMBERS STREET, NEW YORK.

STYLE 323.

15 A—1 lb. 8 oz.

12-POINT ANTIQUE CONDENSED, No. 323.

\$1.00.

**WHO CAN BE WISE, AMAZED, TEMPERATE, AND FURIOUS,
LOYAL, AND NEUTRAL, IN A MOMENT? NO MAN 1234**

12 A—2 lb. 10 oz.

20-POINT ANTIQUE CONDENSED, No. 323.

\$1.60.

**THAT EXPEDITION OF MY VIOLENT LOVE
DID OUTFRAN THE PAUSER REASON 123**

10 A—3 lb. 6 oz.

24-POINT ANTIQUE CONDENSED, No. 323.

\$1.90.

**AND HIS GASH'D STABS LOOK'D LIKE
A RED BREACH IN NATURE 123**

8 A—5 lb. 14 oz.

36-POINT ANTIQUE CONDENSED, No. 323.

\$3.30.

**WHO COULD REFRAIN THAT
HAD A HEART TO LOVE 2**

5 A—6 lb.

48-POINT ANTIQUE CONDENSED, No. 323.

\$3.25.

ULYSSES S. GRANT 2

V. B. MUNSON, SUCCESSOR TO
GEO. BRUCE'S SON & CO., 13 CHAMBERS STREET, NEW YORK.

STYLE 332.

30 A-1 lb. 6 oz. 5-POINT ANTIQUE EXTENDED, No. 332. \$2.50.

**OWING TO THE EXTENDED NATURE OF THIS SERIES,
EXTENDED REMARKS ARE CONDENSED 1234567**

30 A-2 lb. 6-POINT ANTIQUE EXTENDED, No. 332. \$2.30.

**CAPTAIN, I HAVE TO REPORT THAT THERE
HAS BEEN AN EXPLOSION, AND 1234**

30 A-2 lb. 14 oz. 8-POINT ANTIQUE EXTENDED, No. 332. \$2.60.

**AS THE SHIP IS SINKING, I THINK I'LL
JUST MAKE MY ESCAPE NOW 123**

20 A-3 lb. 2 oz. 10-POINT ANTIQUE EXTENDED, No. 332. \$2.30.

**AU REVOIR, CAP! I'LL SEE YOU
ON THE OTHER SHORE 123**

15 A-3 lb. 10 oz. 12-POINT ANTIQUE EXTENDED, No. 332. \$2.40.

THE EMERALD ISLE 12

15 A-6 lb. 2 oz. 16-POINT ANTIQUE EXTENDED, No. 332. \$3.70.

DEWEY PARADE 2

12 A-8 lb. 4 oz. 20-POINT ANTIQUE EXTENDED, No. 332. \$4.95.

HUMAN FISH 3

8 A-8 lb. 24-POINT ANTIQUE EXTENDED, No. 332. \$4.50.

COLUMBIA 2

8 A-10 lb. 12 oz. 28-POINT ANTIQUE EXTENDED, No. 332. \$5.95.

VERBUM 2

V. B. MUNSON, SUCCESSOR TO
GEO. BRUCE'S SON & CO., 13 CHAMBERS STREET, NEW YORK.

STYLE 631.

5 a 5 A
12 lb. 2 oz.

48-POINT ANTIQUE EXTRA CONDENSED, No. 631.

\$8.75.

**MY YOUNGER
Remembrance 23**

5 a 5 A
21 lb. 4 oz.

60-POINT ANTIQUE EXTRA CONDENSED, No. 631.

\$13.60.

**SOUNDS
Harmonious 8**

4 a 4 A
34 lb. 8 oz.

84-POINT ANTIQUE EXTRA CONDENSED, No. 631.

\$20.70.

TURney 6

V. B. MUNSON, SUCCESSOR TO
GEO. BRUCE'S SON & CO., 13 CHAMBERS STREET, NEW YORK.

STYLE 632.

60 & 30 A
2 lb. 6 oz.

8-POINT ANTIQUE EXTRA CONDENSED, No. 632.

\$3.80.

OUR FEARS IN BANQUO STICK DEEP, AND IN HIS ROYALTY OF NATURE REIGNS THAT WHICH
Would be fear'd: 'tis much he dares; and, to that dauntless temper of his mind, he hath a wisdom that doth
guide his valour to act in safety. There is none but he whose being I do fear; 1234567890

40 & 20 A
2 lb. 6 oz.

10-POINT ANTIQUE EXTRA CONDENSED, No. 632.

\$3.10.

AND UNDER HIM MY GENIUS IS REBUK'D, AS, 'TIS SAID, MARK ANTONY'S WAS
By Caesar. He chid the sisters, when first they put the name of king upon me, and bade them
speak to him; then, prophet-like, they hail'd him father to a line of kings: 1234

30 & 15 A
2 lb. 10 oz.

12-POINT ANTIQUE EXTRA CONDENSED, No. 632.

\$3.05.

UPON MY HEAD THEY PLAC'D A FRUITLESS CROWN, AND PUT A
Barren sceptre in my gripe; thence to be wrench'd with an unlineal hand, no
son of mine succeeding. If it be so, for Banquo's issue 1234

25 & 12 A
3 lb. 12 oz.

18-POINT ANTIQUE EXTRA CONDENSED, No. 632.

\$3.75.

HAVE I FIL'D MY MIND; FOR THEM THE GRACIOUS
Duncan have I murther'd: put rancours in the vessel of my peace, only
for them; and mine eternal jewel given to the common 1234

25 & 12 A
5 lb. 4 oz.

22-POINT ANTIQUE EXTRA CONDENSED, No. 632.

\$4.75.

ENEMY OF MAN, TO MAKE THEM KINGS, THE
Seed of Banquo kings! Rather than so, come, fate, into
the list, and champion me to the utterance 123

V. B. MUNSON, SUCCESSOR TO
GEO. BRUCE'S SON & CO., 13 CHAMBERS STREET, NEW YORK.

STYLES 632 AND 324.

20 a 10 A
7 lb. 8 oz.

28-POINT ANTIQUE EXTRA CONDENSED, No. 632.

\$6.45.

O, GENTLE LADY, 'tis not for you to hear 12

15 a 8 A
9 lb. 14 oz.

40-POINT ANTIQUE EXTRA CONDENSED, No. 632.

\$7.70.

IN WOMAN'S EAR 'twould kill 12

12 a 7 A
10 lb. 10 oz.

48-POINT ANTIQUE EXTRA CONDENSED, No. 632.

\$7.65.

CONTENDING against time 12

60 a 30 A
2 lb. 12 oz.

8-POINT ANTIQUE CONDENSED, No. 324.

\$2.50.

SCREW YOUR COURAGE TO THE STICKING POINT, AND WE'LL NOT FAIL.

When Duncan is asleep, his two chamberlains will I with wine and wassel so convince,
that memory, the warder of the brain, shall be a fume, 1234567890

40 a 20 A
3 lb. 6 oz.

10-POINT ANTIQUE CONDENSED, No. 324.

\$2.50.

AND THE RECEIPT OF REASON A LIMBECK ONLY.

When in swinish sleep their drenched natures lie, as in a death,
what cannot you and I perform 1234567890

30 a 15 A
3 lb. 2 oz.

12-POINT ANTIQUE CONDENSED, No. 324.

\$2.05.

UPON THE UNGUARDED DUNCAN? WHAT

Upon his spongy officers, who shall bear the guilt 1234

25 a 12 A
5 lb. 8 oz.

18-POINT ANTIQUE CONDENSED, No. 324.

\$3.30.

I DARE DO ALL THAT MAY BECOME
A man: and he who dares do more, is none 12

V. B. MUNSON, SUCCESSOR TO
GEO. BRUCE'S SON & CO., 13 CHAMBERS STREET, NEW YORK.

STYLE 634.

30 A 6-POINT ANTIQUE EXTRA CONDENSED, No. 634. \$1.25.
10 oz.

AVAUNT! AND QUIT MY SIGHT! LET THE EARTH HIDE THEE! THY BONES ARE MARROWLESS, THY BLOOD IS COLD;
THOU HAST NO SPECULATION IN THOSE EYES WHICH THOU DOST GLARE WITH! 1234567890

30 A 8-POINT ANTIQUE EXTRA CONDENSED, No. 634. \$1.80.
1 lb. 2 oz.

APPROACH THOU LIKE THE RUGGED RUSSIAN BEAR, THE ARM'D RHINOCEROS, OR THE FEROCIOUS
TIGER: TAKE ANY SHAPE BUT THAT, MY FIRM NERVES SHALL NEVER TREMBLE; 1234

20 A 10-POINT ANTIQUE EXTRA CONDENSED, No. 634. \$1.65.
1 lb. 4 oz.

OR, BE ALIVE AGAIN, AND DARE ME TO THE DESERT WITH THY SWORD; IF
TREMBLING I INHABIT THEN, PROTEST ME THE BABY OF A GIRL 1234

15 A 12-POINT ANTIQUE EXTRA CONDENSED, No. 634. \$1.60.
1 lb. 6 oz.

DRINK TO THE GENERAL JOY OF THE WHOLE TABLE, AND TO OUR
DEAR FRIEND BANQUO: WOULD HE WERE HERE 12345

12 A 18-POINT ANTIQUE EXTRA CONDENSED, No. 634. \$2.00.
2 lb.

LET FALL THY BLADE ON VULNERABLE CRESTS 1234

10 A 24-POINT ANTIQUE EXTRA CONDENSED, No. 634. \$2.50.
2 lb. 12 oz.

MAKE MY HEART KNOCK AT MY RIBS 123

8 A 36-POINT ANTIQUE EXTRA CONDENSED, No. 634. \$3.80.
4 lb. 10 oz.

SO RUNS 'GAINST REASON 12

5 A 48-POINT ANTIQUE EXTRA CONDENSED, No. 634. \$3.70.
5 lb. 2 oz.

LAY ON, MACDUFF 12

V. B. MUNSON, SUCCESSOR TO
GEO. BRUCE'S SON & CO., 13 CHAMBERS STREET, NEW YORK.

STYLE 633.

12 A—1 lb. 8 oz.

18-POINT GRECIAN, No. 633.

\$1.50.

**O, SPLENDID OLD MAN! HOW WELL IN THEE APPEARS THE CONSTANT
SERVICE OF THE ANTIQUE WORLD, WHEN 1234567890**

10 A—2 lb. 8 oz.

24-POINT GRECIAN, No. 633.

\$2.25.

**SERVICE SWEAT FOR DUTY, AND NOT FOR MEED!
THOU ART NOT FOR THE FASHION 12345**

8 A—5 lb.

36-POINT GRECIAN, No. 633.

\$4.10.

**OF THESE TIMES, WHEN NONE
WILL SWEAT BUT 1234**

5 A—5 lb. 4 oz.

48-POINT GRECIAN, No. 633.

\$3.80.

FOR PROMOTION! 1234

5 A—10 lb. 12 oz.

60-POINT GRECIAN, No. 633.

\$6.90.

THE VITAGRAPH 4

V. B. MUNSON, SUCCESSOR TO
GEO. BRUCE'S SON & CO., 13 CHAMBERS STREET, NEW YORK.

STYLE 633.

4 A—14 lb. 8 oz.

84-POINT GRECIAN, No. 633.

\$8.70.

AUTOMOBILE 2

4 A—24 lb. 10 oz.

120-POINT GRECIAN, No. 633.

\$14.30.

STEAMER

3 A—26 lb.

144-POINT GRECIAN, No. 633.

\$14.55.

JOYFUL

V. B. MUNSON, SUCCESSOR TO
GEO. BRUCE'S SON & CO., 13 CHAMBERS STREET, NEW YORK.

STYLE 341.

60 a 30 A
1 lb. 10 oz.

6-POINT ITALIAN CONDENSED, No. 341.

\$1.90.

THUS HAVE I POLITICLY BEGUN MY REIGN, AND 'TIS MY HOPE TO END SUCCESSFULLY: MY
Falcon now is sharp, and passing empty, and, till she stoop, she must not be full-gorg'd, for then she never looks upon
her lure. Another way I have to man my haggard, to make her come, and know her keeper's
call: that is, to watch her, as we watch these kites, 1234567890

60 a 30 A
2 lb. 14 oz.

8-POINT ITALIAN CONDENSED, No. 341.

\$2.60.

THAT BATE, AND BEAT, AND WILL NOT BE OBEDIENT. SHE EAT NO
Meat to-day, nor none shall eat; last night she slept not, nor to-night she shall not; as
with the meat, some undeserved fault I'll find about the making
of the bed; and here I'll fling the pillow, 12345

40 a 20 A
3 lb. 2 oz.

10-POINT ITALIAN CONDENSED, No. 341.

\$2.30.

THERE THE BOLSTER, THIS WAY THE COVERLET,
Another way the sheets: Ay, and amid this hurly, I intend that all is
done in reverend care of her. And, in conclusion,
she shall watch all night, and 123456

30 a 15 A
4 lb.

12-POINT ITALIAN CONDENSED, No. 341.

\$2.65.

IF SHE CHANCE TO NOD I'LL RAIL AND
Brawl, and with the clamour keep her still awake.
This is one way to kill a wife with
kindness, and thus 1234

25 a 12 A
5 lb. 2 oz.

18-POINT ITALIAN CONDENSED, No. 341.

\$3.10.

I'LL CURB HER MAD AND HEADSTRONG
Humour. He that knows better how to tame a
shrew, now let him speak; 'tis naught
but charity to show. 12345

V. B. MUNSON, SUCCESSOR TO
GEO. BRUCE'S SON & CO., 13 CHAMBERS STREET, NEW YORK.

25 a 12 A
9 lb. 14 oz.

22-POINT ITALIAN CONDENSED, No. 341.

\$5.50.

WHAT, DID HE MARRY ME
To famish me? Beggars at father's
door have a present alms, 123

20 a 10 A
10 lb. 8 oz.

28-POINT ITALIAN CONDENSED, No. 341.

\$5.90.

BUT I, WHO NEVER
Knew how to entreat, or never
needed to entreat, 123

15 a 8 A
15 lb. 12 oz.

36-POINT ITALIAN CONDENSED, No. 341.

\$8.80.

AM STARVED
For meat, and oh, so 12

12 a 7 A
20 lb. 4 oz.

48-POINT ITALIAN CONDENSED, No. 341.

\$10.95.

GIDDY FROM
Lack of sleep! 12

STYLE 640.

30 A—1 lb. 10 oz.

8-POINT RUNIC, No. 640.

\$1.45.

WILT THOU REACH STARS, BECAUSE THEY SHINE ON THEE? 1234567

20 A—1 lb. 12 oz.

10-POINT RUNIC, No. 640.

\$1.30.

WILT THOU ASPIRE TO GUIDE THE HEAVENLY CAR 1234

15 A—1 lb. 14 oz.

12-POINT RUNIC, No. 640.

\$1.25.

GO, BASE INTRUDER! O'ERWEENING SLAVE! 12

15 A—3 lb.

16-POINT RUNIC, No. 640.

\$1.80.

RESERVE THY FAWNING SMILES 123

12 A—3 lb. 14 oz.

20-POINT RUNIC, No. 640.

\$2.30.

MY EARS ARE STOPP'D, SIR 12

10 A—4 lb. 14 oz.

24-POINT RUNIC, No. 640.

\$2.70.

AND IN DUMB SILENCE 2

8 A—7 lb. 4 oz.

36-POINT RUNIC, No. 640.

\$4.05.

O, GIVE US A REST 4

5 A—7 lb. 12 oz.

48-POINT RUNIC, No. 640.

\$4.20.

OR A HOLIDAY 4

V. B. MUNSON, SUCCESSOR TO
GEO. BRUCE'S SON & CO., 13 CHAMBERS STREET, NEW YORK.

STYLE 641.

60 a 30 A—2 lb. 6-POINT RUNIC, No. 641. \$2.30.

**THERE'S NOTHING SITUATE UNDER HEAVEN'S EYE BUT HATH HIS BOUND, IN EARTH,
In sea, in sky: the beasts, the fishes, and the winged fowls are their males' subjects, 123456789**

60 a 30 A—3 lb. 12 oz. 8-POINT RUNIC, No. 641. \$3.40.

**AND AT THEIR CONTROLS: MEN, MORE DIVINE, THE MASTERS
Of all these, lords of the wide world and wide watery seas, 1234567**

40 a 20 A—3 lb. 14 oz. 10-POINT RUNIC, No. 641. \$2.90.

**INDUED WITH INTELLECTUAL SENSE AND SOULS, AND
Of more pre-eminence than fish and fowls, are masters 123**

30 a 15 A—4 lb. 4 oz. 12-POINT RUNIC, No. 641. \$2.80.

**TO THEIR FEMALES, AND THEIR LORDS,
Then let your will attend on their accords 1234**

25 a 12 A—6 lb. 4 oz. 18-POINT RUNIC, No. 641. \$3.75.

THERE IS SOMETHING in the wind 123

25 a 12 A—8 lb. 2 oz. 20-POINT RUNIC, No. 641. \$4.90.

BACK, SLAVE, or I will break 123

20 a 10 A—10 lb. 6 oz. 24-POINT RUNIC, No. 641. \$5.80.

DID YOU converse with 12

12 a 7 A—19 lb. 8 oz. 48-POINT RUNIC, No. 641. \$10.55.

COMEDY of Errors 1

V. B. MUNSON, SUCCESSOR TO
GEO. BRUCE'S SON & CO., 13 CHAMBERS STREET, NEW YORK.

STYLES 331 AND 643.

30 A—1 lb. 4 oz. 5-POINT ANTIQUE EXTENDED, No. 331. \$2.25.

GOOD MORNING, MASTERS; PUT YOUR TORCHES OUT, MEN.
THE WOLVES HAVE PRAY'D: AND LOOK, THE GENTLE
DAY DAPPLES THE DROWSY EAST WITH
SPOTS OF GRAY 1234567890

60 a 30 A—3 lb. 14 oz. 8-POINT EXTENDED RUNIC, No. 643. \$3.50.

SO MAY OUTWARD SHOWS BE LEAST THEMSELVES;
The world is still deceiv'd with ornament. In law, what plea so tainted
and corrupt, but, being season'd with a gracious voice,
obscures the show of evil? 1234567890

40 a 20 A—3 lb. 12 oz. 10-POINT EXTENDED RUNIC, No. 643. \$2.80.

IN RELIGION, WHAT DAMNED ERROR BUT
Some sober brow will bless it and approve it with a text,
hiding the grossness with fair ornament?
There is no vice so simple, 123

30 a 15 A—4 lb. 12 oz. 12-POINT EXTENDED RUNIC, No. 643. \$3.15.

BUT ASSUMES SOME MARK OF
Virtue on his outward parts. There be many
cowards, whose hearts are all as
false as stayers of sand, 12

25 a 12 A—7 lb. 6 oz. 18-POINT EXTENDED RUNIC, No. 643. \$4.45.

WEAR YET UPON THEIR
Chins the fierce beards of Hercules
and frowning Mars, 123

V. B. MUNSON, SUCCESSOR TO
GEO. BRUCE'S SON & CO., 13 CHAMBERS STREET, NEW YORK.

STYLE 642.

60 a 30 A—2 lb. 12 oz.

6-POINT CELTIC, No. 642.

\$3.20.

DOWN BY A RILL THERE'S A LITTLE STILL, WHERE THE
Smoke curls up to the sky; And you can tell, by a whiff of the smell, that
there's whiskey, boys, close by. For 1234567890

60 a 30 A—4 lb. 10 oz.

8-POINT CELTIC, No. 642.

\$4.15.

IT FILLS THE AIR WITH A PERFUME RARE,
And between both me and you, as home we roll we'll take
another bowl of the real old mountain dew 12

40 a 20 A—4 lb. 10 oz.

10-POINT CELTIC, No. 642.

\$3.45.

YE GRANGERS ALL FROM DONEGAL,
Galway and Leitrim too, Off with your coats and
wet your throats with 1234567890

30 a 15 A—4 lb. 12 oz.

12-POINT CELTIC, No. 642.

\$3.15.

THE REAL OLD MOUNTAIN DEW.
Then away with your pills, for it cures the
ills of Christian, Pagan and Jew 123

25 a 12 A—8 lb. 10 oz.

18-POINT CELTIC, No. 642.

\$5.20.

THE SWEET POTHEEN
From Ireland so green--I don't
know last line, do you? 12

20 a 10 A—12 lb.

24-POINT CELTIC, No. 642.

\$6.70.

BALM OF GILEAD
White Man's Burden 2

V. B. MUNSON, SUCCESSOR TO
GEO. BRUCE'S SON & CO., 13 CHAMBERS STREET, NEW YORK.

STYLE 653.

30 A—1 lb. 2 oz.

6-POINT CELTIC, No. 653.

\$1.30.

O HEAVENS! WHY DOES MY BLOOD THUS MUSTER TO MY HEART, MAKING
BOTH IT UNABLE FOR ITSELF, AND DISPOSSESSING 1234567890

30 A—2 lb.

8-POINT CELTIC, No. 653.

\$1.80.

ALL MY OTHER PARTS OF THEIR NECESSARY FITNESS?
SO PLAY THE FOOLISH THROGS WITH 12345

20 A—2 lb. 6 oz.

10-POINT CELTIC, No. 653.

\$1.75.

ONE THAT SWOONS: CROWD IN ALL TO
HELP HIM, AND SO STOP THE 1234

15 A—2 lb. 14 oz.

12-POINT CELTIC, No. 653.

\$1.90.

AIR BY WHICH HE SHOULD BE
REVIVED. VERY TRUE 123

12 A—4 lb. 4 oz.

18-POINT CELTIC, No. 653.

\$2.55.

THE HAND THAT HATH
MADE YOU FAIR 12

10 A—6 lb. 10 oz.

24-POINT CELTIC, No. 653.

\$3.70.

HAS ALSO MADE
YOU GOOD 12

10 A—9 lb. 4 oz.

28-POINT CELTIC, No. 653.

\$5.20.

ACCOUNTED 2

V. B. MUNSON, SUCCESSOR TO
GEO. BRUCE'S SON & CO., 13 CHAMBERS STREET, NEW YORK.

STYLE 646.

30 A-1 lb. 4 oz.

6-POINT OUTLINE, No. 646.

\$2.50.

AS A SOLDIER IT WAS THE FATE OF WASHINGTON TO WIN
FEW VICTORIES. HIS MILITARY CAREER WAS
NO SPECTACULAR BLAZE OF TRIUMPH. HE FOUGHT
ALMOST ALWAYS AT A DISADVANTAGE

30 A-2 lb. 6 oz.

8-POINT OUTLINE, No. 646.

\$3.80.

AND HIS BATTLES WERE MORE OFTEN LOST THAN
WON. HIS VERY FIRST REAL BATTLE, AT
MONT MERRILL, ENDED NOT ONLY IN DEFEAT
BUT IN A CAPTIVITY DEATH

40 a 20 A-4 lb. 10 oz.

10-POINT OUTLINE, No. 646.

\$6.00.

IN THE WAR OF THE REVOLUTION
He was beaten again and again. But the people
perceived that his defeats were
never due to his fault, while his 123456

30 a 15 A-6 lb. 8 oz.

14-POINT OUTLINE, No. 646.

\$7.30.

VICTORIES WERE ALL HIS
Own. With the resources at command
he accomplished all that
was possible, and his 123456

V. B. MUNSON, SUCCESSOR TO
GEO. BRUCE'S SON & CO., 13 CHAMBERS STREET, NEW YORK.

STYLE 1010.

15 A—1 lb. 12 oz.

12-POINT ORNAMENTED, No. 1010.

\$2.05.

THIS NEAT AND ATTRACTIVE SERIES OF OUTLINES
IS MEETING WITH UNIVERSAL APPROVAL
VERY EFFECTIVE FOR NEWSPAPER DISPLAY 123

12 A—2 lb. 14 oz.

18-POINT ORNAMENTED, No. 1010.

\$2.90.

CUT PRICES IN GENTS' FURNISHINGS
PATENT MEDICINES AND FURS
TOBACCO HARDWARE CORSETS 123

10 A—4 lb. 6 oz.

24-POINT ORNAMENTED, No. 1010.

\$3.95.

SEE ME AT THE FOUNTAIN
UNACCOMPANIED
COLD SPARKLING FREE 12

8 A—7 lb. 6 oz.

36-POINT ORNAMENTED, No. 1010.

\$6.05.

ANNUAL ABLUTIONS
INJURIOUS 12

V. B. MUNSON, SUCCESSOR TO
GEO. BRUCE'S SON & CO., 13 CHAMBERS STREET, NEW YORK.

STYLE 1010.

5 A—8 lb. 8 oz.

48-POINT ORNAMENTED, No. 1010.

\$6.10.

ADMINISTRATE
ALBANY 12

5 A—16 lb. 12 oz.

72-POINT ORNAMENTED, No. 1010.

\$10.70.

GOLCONDA
RUBY 7

4 A—26 lb.

96-POINT ORNAMENTED, No. 1010.

\$15.60.

STORE 7

V. B. MUNSON, SUCCESSOR TO
GEO. BRUCE'S SON & CO., 13 CHAMBERS STREET, NEW YORK.

STYLE 1040.

30 A—1 lb. 6 oz. 6-POINT ORNAMENTED, No. 1040. \$2.75.

ONE HUNDRED YEARS AGO TO-DAY, THURSDAY, DECEMBER 14,
AMERICA LOST THE GREATEST MAN THE NATION
EVER POSSESSED. OTHER FIGURES GROW SMALLER 12345

30 A—2 lb. 4 oz. 8-POINT ORNAMENTED, No. 1040. \$3.60.

AS THEY RECEDE INTO THE DEPTHS OF HISTORY, BUT
WASHINGTON LOOMS STEADILY HIGHER
AS THE ROLL OF HIS SUCCESSORS LENGTHENS 123

20 A—2 lb. 8 oz. 10-POINT ORNAMENTED, No. 1040. \$3.25.

THE FIRST PRESIDENT'S POSITION AND
ACHIEVEMENTS BECOME MORE
CONSPICUOUSLY UNIQUE 1234567890

15 A—2 lb. 10 oz. 12-POINT ORNAMENTED, No. 1040. \$3.05.

AMERICA PRODUCED NO GEORGE
WASHINGTONS BEFORE 1732
NONE SINCE DECEMBER 14, 1799

12 A—5 lb. 18-POINT ORNAMENTED, No. 1040. \$5.00.

AS A SOLDIER HE HAD
NO OPPORTUNITY
TO SHOW HIS SIZE 12

V. B. MUNSON, SUCCESSOR TO
GEO. BRUCE'S SON & CO., 13 CHAMBERS STREET, NEW YORK.

STYLE 1040.

10 A—6 lb. 8 oz.

24-POINT ORNAMENTED, No. 1040.

\$5.85.

GREAT GENERALS
OFTEN POOR
STATESMEN 123

8 A—10 lb. 12 oz.

36-POINT ORNAMENTED, No. 1040.

\$8.80.

PRESIDENT'S
UNIQUE
POSITION 4

5 A—12 lb. 10 oz.

48-POINT ORNAMENTED, No. 1040.

\$9.10.

PERFECT
TYPE 8

V. B. MUNSON, SUCCESSOR TO
GEO. BRUCE'S SON & CO., 13 CHAMBERS STREET, NEW YORK.

STYLE 1037.

20 A—2 lb. 8 oz.

10-POINT ORNAMENTED, No. 1037.

\$3.25.

**ISAAC NEWTON LIKENED HIMSELF TO A
CHILD ON THE SEASHORE
GATHERING BRIGHT PEBBLES 1234**

15 A—2 lb. 6 oz.

12-POINT ORNAMENTED, No. 1037.

\$2.75.

**TIME FOREVER THE CRADLE OF HOPE
CONSTANTLY FLIES, YET
OVERCOMES ALL THINGS BY 123**

12 A—4 lb. 4 oz.

18-POINT ORNAMENTED, No. 1037.

\$4.25.

**HOW TEMPUS DOES FUGIT
TIME FOR DINNER 123**

12 A—7 lb. 2 oz.

22-POINT ORNAMENTED, No. 1037.

\$6.40.

**TWO PAILS OF BEER
ONE SINKER 12**

10 A—8 lb. 12 oz.

28-POINT ORNAMENTED, No. 1037.

\$7.50.

**WORKINGMAN'S
BANQUET 12**

V. B. MUNSON, SUCCESSOR TO
GEO. BRUCE'S SON & CO., 18 CHAMBERS STREET, NEW YORK.

STYLE 1066.

20 A—2 lb. 2 oz.

10-POINT ORNAMENTED, No. 1066.

\$2.75.

**ON THESE ISLANDS ARE THE NESTING-PLACES OF
COUNTLESS THOUSANDS OF BIRDS 123**

15 A—2 lb. 4 oz.

12-POINT ORNAMENTED, No. 1066.

\$2.60.

**IN SOME PLACES THE YOUNG GULLS AND
OTHER FLUFFY INFANTS 123**

12 A—3 lb. 8 oz.

18-POINT ORNAMENTED, No. 1066.

\$3.50.

**WOULD PROWL AROUND UNDER
OUR FEET IN THE 123**

10 A—5 lb. 8 oz.

24-POINT ORNAMENTED, No. 1066.

\$4.95.

**MOST AWKWARD AND
LUDICROUS WAY 12**

8 A—9 lb.

36-POINT ORNAMENTED, No. 1066.

\$7.40.

**NOISY PARENTS
HOVERING 2**

V. B. MUNSON, SUCCESSOR TO
GEO. BRUCE'S SON & CO., 13 CHAMBERS STREET, NEW YORK.

STYLE 1537.

40 a 20 A—3 lb. 6 oz. 10-POINT ORNAMENTED, No. 1537. \$4.40.

HE SMILED GRIMLY AND MADE NO ANSWER
But sat with knitted brows looking out across the leafless trees
of the wind-swept plaza 1234567890

30 a 15 A—4 lb. 12-POINT ORNAMENTED, No. 1537. \$4.65.

AT THE SOUTHERN END OF THE PLAZA
The band was playing waltzes that came throbbing
through the trees and beating 123

25 a 12 A—5 lb. 14 oz. 18-POINT ORNAMENTED, No. 1537. \$5.90.

AGAINST THE PLATE GLASS
In vain efforts to add to the tortures that
already were unbearable 123

25 a 12 A—8 lb. 10 oz. 22-POINT ORNAMENTED, No. 1537. \$7.75.

HIS FACE WAS SERIOUS
And he was apparently listening 12

20 a 10 A—11 lb. 2 oz. 28-POINT ORNAMENTED, No. 1537. \$9.55.

SHE TOO TURNED
And wandered down to 23

15 a 8 A—16 lb. 2 oz. 36-POINT ORNAMENTED, No. 1537. \$13.25.

THE RIVER bank 2

V. B. MUNSON, SUCCESSOR TO
GEO. BRUCE'S SON & CO., 13 CHAMBERS STREET, NEW YORK.

STYLE 1564.

15 a 15 A—2 lb. 14 oz.

12-POINT ORNAMENTED, No. 1564.

\$3.30.

THERE WAS PROBABLY ONLY ONE
Other general living who could have accomplished
what Washington did in 123

12 a 12 A—4 lb. 10 oz.

18-POINT ORNAMENTED, No. 1564.

\$4.65.

THAT DESPERATE RETREAT
Across the wilds of New Jersey in the Fall
and Winter of 1776

10 a 10 A—6 lb. 14 oz.

24-POINT ORNAMENTED, No. 1564.

\$6.20.

ALWAYS FIRST IN
Hearts of his countrymen 12

8 a 8 A—11 lb. 14 oz.

36-POINT ORNAMENTED, No. 1564.

\$9.75.

RECOGNITION
Of sterling worth 12

5 a 5 A—12 lb.

48-POINT ORNAMENTED, No. 1564.

\$8.65.

FIRST nights 4

V. B. MUNSON, SUCCESSOR TO
GEO. BRUCE'S SON & CO., 13 CHAMBERS STREET, NEW YORK.

STYLES 1549 AND 1550.

25 a 12 A—3 lb. 14 oz.

18-POINT ORNAMENTED No. 1549.

\$3.85.

WE FISHED WHEN THE BROOK WAS SO

**Low and the sky so hot that we might as well have thrown our
flies upon the turnpike 123456**

20 a 10 A—6 lb. 4 oz.

24-POINT ORNAMENTED, No. 1549.

\$5.65.

PERHAPS TOO THERE IS A BEVY

Of little dirty nosed nephews and nieces 12

15 a 8 A—10 lb. 8 oz.

36-POINT ORNAMENTED, No. 1549.

\$8.60.

COME TO spend a holiday 12

30 a 15 A—4 lb.

12-POINT ORNAMENTED, No. 1550.

\$4.65.

***Forever Pramping overhead or Raising the old Harry
below, while you are trying to read 1234567890***

25 a 12 A—7 lb. 2 oz.

18-POINT ORNAMENTED, No. 1550.

\$7.15.

***Last and worst is some Fidgety Old
Uncle, forever too cold or too hot 19***

20 a 10 A—11 lb. 2 oz.

24-POINT ORNAMENTED, No. 1550.

\$10.00.

***Impudently kisses your wife
and calls her His Peggy 3***

V. B. MUNSON, SUCCESSOR TO
GEO. BRUCE'S SON & CO., 13 CHAMBERS STREET, NEW YORK.

STYLE 1009.

15 A—2 lb. 4 oz. 12-POINT ORNAMENTED, No. 1009. \$2.60.

INDIGNATION BLAZING IN HIS FACE 1234

12 A—3 lb. 6 oz. 18-POINT ORNAMENTED, No. 1009. \$3.40.

WITH A GESTURE OF DISDAIN 12

12 A—5 lb. 4 oz. 22-POINT ORNAMENTED, No. 1009. \$4.70.

SOME IN SORROW WEPT 12

10 A—7 lb. 28-POINT ORNAMENTED, No. 1009. \$6.00.

NO OTHER GIFT 12

8 A—8 lb. 8 oz. 36-POINT ORNAMENTED, No. 1009. \$6.95.

POSSIBILITIES 12

5 A—11 lb. 4 oz. 48-POINT ORNAMENTED, No. 1009. \$8.10.

MASONIC 9

5 A—17 lb. 60-POINT ORNAMENTED, No. 1009. \$10.90.

LEADING 2

WE ALSO MAKE 72-POINT OF THIS SERIES.

V. B. MUNSON, SUCCESSOR TO
GEO. BRUCE'S SON & CO., 13 CHAMBERS STREET, NEW YORK.

STYLE 1024.

15 A—2 lb.

12-POINT ORNAMENTED, No. 1024.

\$2.30.

**THESE CLUSTERING GEMS THAT GLEAM
WITH DANCING RAYS 1234567**

12 A—3 lb. 8 oz.

18-POINT ORNAMENTED, No. 1024.

\$3.50.

**NO FLAW SHALL MAR, NOR
ACID BLIGHT ASSAIL 12**

10 A—5 lb. 8 oz.

24-POINT ORNAMENTED, No. 1024.

\$4.95.

**AND TURN AND GAZE
AND DREAM 12**

8 A—9 lb. 8 oz.

36-POINT ORNAMENTED, No. 1024.

\$7.80.

**THE LAND, SEA
AND SKY 12**

5 A—10 lb. 4 oz.

48-POINT ORNAMENTED, No. 1024.

\$7.40.

HONESTY 4

V. B. MUNSON, SUCCESSOR TO
GEO. BRUCE'S SON & CO., 13 CHAMBERS STREET, NEW YORK.

STYLE 1025.

15 A—1 lb. 10 oz.

12-POINT ORNAMENTED, No. 1025.

\$1.90.

HIS PURPLE VEINS STOOD OUT LIKE IRON RODS 12

12 A—3 lb.

18-POINT ORNAMENTED, No. 1025.

\$3.00.

HALF HIDDEN BY THE YERDURE 12

10 A—4 lb. 12 oz.

24-POINT ORNAMENTED, No. 1025.

\$4.25.

WITH SCOWLING FACE 12

8 A—8 lb. 2 oz.

36-POINT ORNAMENTED, No. 1025.

\$6.65.

CAME ON A PAGE 12

5 A—9 lb. 12 oz.

48-POINT ORNAMENTED, No. 1025.

\$7.00.

WONDERS 17

5 A—16 lb.

72-POINT ORNAMENTED, No. 1025.

\$10.25.

ANNALS

WE ALSO MAKE 96-POINT AND 110-POINT OF ABOVE SERIES.

V. B. MUNSON, SUCCESSOR TO
GEO. BRUCE'S SON & CO., 13 CHAMBERS STREET, NEW YORK.

BINNER SERIES

72 POINT

4 A 5 a \$17 00

BRICK
Hue Golf
Shoes

60 POINT

4 A 5 a \$12 25

CINDER
Path Road
Bicycle

BINNER SERIES

54 POINT

4 A 5 a \$10 25

**BEST HIGH
Price Onions**

48 POINT

4 A 5 a \$7 75

**INDIAN MEAL
Flour and Hams**

36 POINT

5 A 8 a \$5 50

**COMIC SKETCH
With Lead Pencils
Not Traced**

BINNER SERIES

30 POINT

6 A 9 a \$5 00

**MAGNIFICENT
Harbor and River View**

24 POINT

8 A 10 a \$4 50

**RADICAL CHANGES
During Presidential Election**

18 POINT

10 A 16 a \$4 00

**BRITISH NORTH AMERICA
Raising Numerous Valuable Equines
Thoroughly Acclimated**

12 POINT

16 A 20 a \$3 25

**GRAND HOLIDAY
Printers and Editorial
Fabricators**

10 POINT

20 A 26 a \$3 00

**TWILIGHT HUSH
Hence the Shadows Growing
Unsurpassable**

8 POINT

22 A 30 a \$2 75

**WORCESTER CELEBRATION
Attended by Small Army from Ohio
and California, with Bright Bunting**

6 POINT

24 A 36 a \$2 50

**FACE OF LATE TYPOGRAPHY
Handsome, Durable and Comprehensive the
Fervor of its Reception Should be Unmixed**

1 2 3 4 5 6 7 8 9 0

1 2 3 4 5 6 7 8 9 0

QUENTELL SERIES

72 POINT

4 A 5 a \$17 00

TIME Runs

60 POINT

4 A 5 a \$12 25

Count GIRLS

54 POINT

4 A 5 a \$10 25

NIGHT Return

48 POINT

4 A 5 a \$7 75

Order GENERAL

42 POINT

4 A 6 a \$7 25

**EXCURSIONS
Divorce Register**

QUENTELL SERIES

36 POINT

5 A 8 a \$5 50

PERFORMANCES
Remarkable Country

30 POINT

6 A 9 a \$5 00

CORRESPONDENCE
Distinguished Questions

24 POINT

8 A 10 a \$4 00

ENTERPRISING MERCHANT
Sending Phonograph Message

18 POINT

10 A 16 a \$3 25

UNREALIZATION
Beautiful Floriated

14 POINT

12 A 18 a \$3 25

BASEBALL GAMES
Enchanted Amusement

12 POINT

16 A 20 a \$3 00

POCKET ESTIMATE
Provocation and Sensation

10 POINT

20 A 26 a \$2 75

PHOTOGRAPHERS RESOLUTION
Beautiful, Glorious and Charming

8 POINT

22 A 30 a \$2 50

THROUGH COUNTLESS DANGERS
Charitable Society Distributing Clothing
1234567890

6 POINT

24 A 36 a \$2 25

PATENT CYLINDER PRINTING MACHINE
Magnificent Assortment Woodwork Exhibited
1234567890

QUENTELL FRACTIONS

$\frac{1}{4}$ $\frac{1}{2}$ $\frac{3}{4}$ $\frac{1}{8}$ $\frac{3}{8}$ $\frac{5}{8}$ $\frac{7}{8}$ $\frac{1}{3}$ $\frac{2}{3}$ $\frac{1}{4}$ $\frac{1}{2}$ $\frac{3}{4}$ $\frac{1}{8}$ $\frac{3}{8}$ $\frac{5}{8}$ $\frac{7}{8}$ $\frac{1}{3}$ $\frac{2}{3}$

PRICES: 6 POINT TO 24 POINT, INCLUSIVE, 50 OTS. PER POINT; 30 POINT AND 36 POINT, 75 OTS. PER POINT.

Made for all sizes on this page

72 POINT

3 A 4 a \$8 50

DESERVING
Student tried
for Diplomas

60 POINT

3 A 5 a \$7 00

REMARKABLE
Time was made
on the Voyages

48 POINT

4 A 7 a \$8 00

BRIGHT PERSONS
Blessed with Sound
Health and Millions

36 POINT

6 A 9 a \$5 00

CHARITABLE REMEDY
We should always assist
those who are deserving

30 POINT

8 A 12 a \$4 50

INTREPID AND PATRIOTIC
They stood on the deck like
heroes, so firmly intent were
they on the seizure of the fort

24 POINT

12 A 18 a \$4 00

ADVANTAGES OF KNOWLEDGE

FORTUNE may be left to us by our parents, but the resources of education must be developed by ourselves, or we must lack it forever

48 POINT SCHÖEFFER OLD STYLE INITIALS 3 A \$4 00

10 POINT

25 A 50 a \$2 25

FOR HIS GREAT QUALIFICATION PETER SCHÖEFFER WAS MADE MANAGER OF THE OFFICE IN MENTZ

PETER SCHÖEFFER before the age of twenty years was considered a perfect copyist of old manuscripts, with a slight knowledge of printing taught him by Gutenberg. He attracted the attention of Fust, who found in him one who could cleverly manage a Printing Office, and by adding to his great knowledge the acquirement of ingenuity, he made many acceptable changes in the pages of the Bible and Psalter. Between 1462 and 1464 turbulent times occurred in Mentz, and business was at a standstill.

24 POINT SCHÖEFFER OLD STYLE INITIALS 6 A \$2 50

18 POINT

15 A 25 a \$3 50

DIFFICULTY IN CHOOSING COMPANIONS

THE task is a dilemma, but we all should endeavor to make a good selection and not come to hasty conclusions as to the relative value of our friends, for in many instances time may develop a different phase of character, and

36 POINT SCHÖEFFER OLD STYLE INITIALS 4 A \$3 50

15 POINT

18 A 30 a \$3 00

AN IDEA OF DISCOVERING A NEW HEMISPHERE

IT was Columbus, the intrepid Italian, who conceived the idea about the world being round instead of flat, and who sailed off into an unknown sea in the expectation to discover a hemisphere of two continents. Encouraged by the Spanish Crown in his undertaking, he set sail on August 3, 1492, sailing in a westerly direction.

36 POINT SCHÖEFFER OLD STYLE INITIALS 4 A \$3 50

8 POINT

25 A 50 a \$2 00

THE FIRST COPIES OF THE BIBLE DO NOT CONTAIN THE NAME OF THE PRINTER NOR THE YEAR OF PUBLICATION

ONLY a few impressions have been preserved to the present day; indeed, they were entirely lost to the world until the latter half of the eighteenth century, when a copy was found in the library of Cardinal Mazarin in Paris; hence, the few existing copies are generally spoken of as Mazarin Bibles. Some of these were printed on vellum, but the earliest copies were on paper. There are only six copies now extant, two of which are in the United States, one belonging to the collection of Mr. George Brinley, of Connecticut, and the other owned by the late Mr. James Lenox, of New York City. These two copies are on paper. The Brinley copy is said to have a leaf or two in fac-simile, while the Lenox copy is perfect in every respect. This copy now enriches

15 POINT SCHÖEFFER OLD STYLE INITIALS 6 A \$1 50

12 POINT

20 A 40 a \$2 50

FEW THOUGHTFUL POINTS ON THE STUDY OF ASTRONOMY

TO many of us it will be very interesting to note the fact that during the month of August there is to be seen Jupiter and Venus in conjunction. It takes place low down in the western part of the horizon, and will be worth all the trouble we can take to witness such beautiful display; also the conjunction of Jupiter and the Moon, and Venus and the Moon. It is an infrequent occurrence to see these three bodies so close together, and the students should therefore avail themselves of this rare opportunity of viewing them.

24 POINT SCHÖEFFER OLD STYLE INITIALS 6 A \$2 50

48 POINT

4 A 5 a \$7 75

SONG OF HOME
Composed by one
who Never spent
a Minute there 3

36 POINT

5 A 8 a \$5 50

THE RUSTIC BRIDGE
Has been the Subject
for Poets and Artists
ever since the first one
was built ~ Pastoral 8

ARLINGTON SERIES

30 POINT

6 A 9 a \$5 00

ADVANTAGES RECORDED
EVEN if our Prices were
just as high as those of
the average Store, it would
pay you to come miles to
purchase Here ~ ~ \$32.68

24 POINT

8 A 10 a \$4 00

SHOES TO PLEASE EVERYBODY
~ ~ **LATEST FOOTWEAR** ~ ~
THIS Department has earned its
great popularity by Studying
and Filling the wants of Patrons,
who find our Shoes to be as good
as those much more Expensive
~ 1234567890 ~



ARLINGTON SERIES

18 POINT

10A 16a \$3 25

OUR WINTER SALE OF FINE CLOTHING

~ ~ GREATEST VALUES ~ ~

FROM the same manufacturer who sent us the Overcoats which made such a stir among Young Men during the past week, we have bought a lot of Clothes for Men, which go on Sale to-day ~ ~ \$30.24

10 POINT

20 A 26a \$2 75

GRAND EXHIBIT OF IMPORTED AND DOMESTIC MILLINERY

~ ~ OPEN EVENINGS UNTIL TEN ~ ~

TO-DAY'S showing of Trimmed Hats is so unique, so great, so different from any other ever seen, that you should not miss it. This is the fashion center for admirers of all that is stylish and elegant in the Millinery world. Our own special and exclusive designs are side by side with the finest copies of the best foreign models. In this beautiful display, newly trimmed Hats are numbered by the thousands, and have no equal for richness

1 2 3 4 5 6 7 8 9 0

12 POINT

16 A 20a \$3 00

COME AND INSPECT OUR DISPLAY OF ORIENTAL SILKS

~ ~ NOTEWORTHY BARGAINS ~ ~

OUR Silk Salon blooms with a magnificent collection of filmy weaves in all the characteristic New Designs, and we have dressed the Salon in gala attire in their honor; the Japanese Silks are shown in an Oriental booth by themselves. To crown all, the Prices are the same as during the Summer, and means that they are Twenty Per Cent. less than present prices \$238

FLORENTINE HEAVYFACE

48 POINT

4 A 5 a \$7 75

**SOUNDING
Army 9 Packs**

36 POINT

5 A 8 a \$5 50

**PORTSMOUTH
Cruiser 83 Station**

24 POINT

8 A 10 a \$4 50

**REGULAR SOLDIERS
Gentlemanly 25 Characters**

18 POINT

10 A 16 a \$4 00

**AMERICAN
Type 8 Founder**

12 POINT

16 A 20 a \$3 25

**TEXAS RANGERS
Marching to Quincy 8**

10 POINT

20 A 26 a \$3 00

**HUMBUG OINTMENT
Efficacious 9 Medicaments**

8 POINT

22 A 30 a \$2 75

**DELIGHTFUL PAGEANTS
Viewed from a Hundred Stands 24**

6 POINT

24 A 36 a \$2 50

**ENDURE EASTERN HARDSHIPS
Mountain Climbers \$34 were Exhausted**

5 POINT ON 6 POINT

24 A 36 a \$2 50

**BASKING IN WINTERS CHILLY WEATHER
Enjoying the Lavishly-Stocked Larders £254179**

ELZEVIR GOTHIC

60 POINT

3 A 5 a \$11 50

GAMES
Fast Horses

48 POINT

3 A 6 a \$8 00

‡CHARM‡
Roman Guard

36 POINT

5 A 9 a \$6 00

MONUMENTS
Grandeur Described

30 POINT

6 A 12 a \$5 50

‡COUNCILMANIC‡
Independent Convention

ELZEVIR GOTHIC

24 POINT

8 A 16 a \$5 00

MOUNT VESUVIUS
Gorgeous Palaces Destroyed
Violent Eruption

18 POINT

12 A 24 a \$4 50

NATIONAL PREROGATIVE
Liberal Reform Movements Indorsed
Municipal Resolution

14 POINT

15 A 30 a \$4 00

FAMOUS ELOCUTIONISTS ENTERTAIN
Distinguished Orators Receive Congratulations
Linguistic Powers Unsurpassed

12 POINT

18 A 36 a \$3 50

NATIONAL CONVENTION CONSIDERED
International Monetary Questions Frequently Discussed
Organization Committee Reports

10 POINT

20 A 40 a \$3 00

HANDSOME PREMIUMS AWARDED COMPETITORS
Collection of Botanical Specimens and Delicate Wild Flowers
Floricultural and Horticultural Exhibition

8 POINT

22 A 44 a \$2 75

IMPROVEMENT OF MANKIND
Advocating Protection for the Honest
Our Industrial Conditions
1234567890

6 POINT

25 A 50 a \$2 50

MORALS OF THE GENERAL PUBLIC
Dawn of Civilization and Decrease of Crime
Modern Religious Thoughts
1234567890

DORIC ITALIC

60 POINT

4 A 5 a \$15 50

The END

48 POINT

4 A 5 a \$10 75

DOG Carts

36 POINT

5 A 7 a \$8 75

Crowd LARGE

30 POINT

5 A 7 a \$8 50

SPECIAL Markets

24 POINT

6 A 10 a \$5 00

Cheap VEST

18 POINT

8 A 12 a \$4 50

Money FOUND

12 POINT

10 A 20 a \$4 25

RECOGNITION
Entertain Nobleman

10 POINT

12 A 25 a \$4 00

HOSTILE TRIBES
Prepare Twenty Braves

8 POINT

15 A 30 a \$3 75

LECTURING COURSES
Members Securing Tickets
1 2 3 4 5 6 7 8 9 0

6 POINT

18 A 40 a \$3 50

AMBITIOUS AUSTRALIAN
Promises Many Business Chances
1 2 3 4 5 6 7 8 9 0

STYLE 1029.

15 A—2 lb.

12-POINT ORNAMENTED, No. 1029.

\$2.30.

**FAR TO THE NORTH ROSE THE NEXT RANGE
OF MOUNTAINS, AND THROUGH A 123**

12 A—3 lb.

18-POINT ORNAMENTED, No. 1029.

\$3.00.

**BARELY VISIBLE NOTCH THE THIN
SILVER THREAD OF THE 123**

12 A—5 lb.

22-POINT ORNAMENTED, No. 1029.

\$4.50.

**DEEP SHINING RIVER WAS
LOST TO VIEW 123**

10 A—7 lb. 4 oz.

28-POINT ORNAMENTED, No. 1029.

\$6.25.

**TO MEMORY EVER
SO DEAR 12**

8 A—8 lb. 6 oz.

36-POINT ORNAMENTED, No. 1029.

\$6.85.

HE SINGS LIKE A 2

5 A—10 lb. 14 oz.

48-POINT ORNAMENTED, No. 1029.

\$7.85.

FOG HORN 7

WE ALSO MAKE 60 AND 72-POINT OF THIS SERIES.

V. B. MUNSON, SUCCESSOR TO
GEO. BRUCE'S SON & CO., 13 CHAMBERS STREET, NEW YORK.

STYLE 1031.

12 A—5 lb.

20-POINT ORNAMENTED, No. 1031.

\$4.70.

ONE SOLEMN BELL, THAT
CHILLS THE SOUL 12

10 A—7 lb. 6 oz.

24-POINT ORNAMENTED, No. 1031.

\$6.65.

AND IS THE BAR AS
JOLLY STILL 12

10 A—8 lb.

28-POINT ORNAMENTED, No. 1031.

\$6.90.

IT WAS A DISMAL
YULETIDE 12

8 A—10 lb. 2 oz.

36-POINT ORNAMENTED, No. 1031.

\$8.30.

THE WORLD IS
ALL AWRY 2

V. B. MUNSON, SUCCESSOR TO
GEO. BRUCE'S SON & CO., 13 CHAMBERS STREET, NEW YORK.

STYLE 1048.

20 A—1 lb. 10 oz.

10-POINT ORNAMENTED, No. 1048.

\$2.10.

**BECAUSE THE JAGGED HOLES IN THE SOLDIER'S TUNIC
APPEALED TO WHAT WAS BRAVEST IN HIM 123**

15 A—2 lb.

12-POINT ORNAMENTED, No. 1048.

\$2.30.

**HE CROSSED HIMSELF QUICKLY, AND RAISING
HIS HAND SLOWLY TO HIS VISOR 123**

12 A—3 lb. 6 oz.

18-POINT ORNAMENTED, No. 1048.

\$3.40.

**LIFTED HIS HELMET AND POINTED
WITH IT TO THE DOOR 456**

10 A—5 lb. 12 oz.

24-POINT ORNAMENTED, No. 1048.

\$5.15.

**STEPPING QUIETLY, THE
MOB PUSHED OUT 78**

8 A—7 lb. 6 oz.

36-POINT ORNAMENTED, No. 1048.

\$6.05.

WITHOUT EVEN A 4

5 A—9 lb. 6 oz.

48-POINT ORNAMENTED, No. 1048.

\$6.75.

GLANCE AT 4

V. B. MUNSON, SUCCESSOR TO
GEO. BRUCE'S SON & CO., 13 CHAMBERS STREET, NEW YORK.

STYLE 1049.

IN THIS SERIES THE LETTERS A, F, L, T, U, V, W AND Y ARE KERNED AT THE SIDES, ONE-TWELFTH OF THE BODY, AND ARE ACCOMPANIED BY A SPACE TO USE WHEN THE KERN IS UNNECESSARY.

15 A—2 lb. 12 oz. 12-POINT ORNAMENTED, No. 1049. \$3.20.

**THE INTERIOR OF THE BOX WAS
IN PERFECT ORDER 123**

12 A—5 lb. 18-POINT ORNAMENTED, No. 1049. \$5.00.

**AND THE LITTLE ROOM
POSSESSED AN 123**

10 A—8 lb. 2 oz. 24-POINT ORNAMENTED, No. 1049. \$7.30.

**UNDEFINABLE
CHARM 12**

8 A—13 lb. 10 oz. 36-POINT ORNAMENTED, No. 1049. \$11.15.

**ADVANCED
IDEAS 2**

5 A—15 lb. 4 oz. 48-POINT ORNAMENTED, No. 1049. \$11.00.

FRAIL 1

V. B. MUNSON, SUCCESSOR TO
GEO. BRUCE'S SON & CO., 13 CHAMBERS STREET, NEW YORK.

STYLE 1050.

15 A—1 lb. 6 oz.

12-POINT ORNAMENTED, No. 1050.

\$1.60.

WITHOUT WAITING FOR THE OTHERS THE FOUR OUTRIDERS
GALLOPED AHEAD TO THE FIRST CROSS STREET 1234

12 A—2 lb. 6 oz.

18-POINT ORNAMENTED, No. 1050.

\$2.40.

LOOKED UP AND DOWN ITS LENGTH, AND, IN
GREAT ALARM AT WHAT THEY SAW 123

10 A—3 lb. 8 oz.

24-POINT ORNAMENTED, No. 1050.

\$3.15.

MOTIONED THE DRIVER TO GET A
MOVE ON, CROSSED STREET 12

8 A—7 lb.

36-POINT ORNAMENTED, No. 1050.

\$5.75.

AND TOLD HIM TO KEEP
CLOSE IN THE REAR 12

5 A—6 lb. 10 oz.

48-POINT ORNAMENTED, No. 1050.

\$4.75.

SOUL TERRIFYING
ADVENTURES 2

V. B. MUNSON, SUCCESSOR TO
GEO. BRUCE'S SON & CO., 13 CHAMBERS STREET, NEW YORK.

STYLE 1051.

15 A—1 lb. 14 oz.

12-POINT ORNAMENTED, No. 1051.

\$2.15.

**UPON AN ISLAND FORT TOWARD THE EASTERN
SUN A PATRIOT BANNER WAVED 1234**

12 A—3 lb. 4 oz.

18-POINT ORNAMENTED, No. 1051.

\$3.25.

**AND 'NEATH IT IN MARTIAL ARRAY
A NOBLE BAND STOOD 123**

10 A—5 lb. 6 oz.

24-POINT ORNAMENTED, No. 1051.

\$4.85.

**PATIENTLY AWAITING
DAWN OF DAY 123**

8 A—11 lb. 2 oz.

36-POINT ORNAMENTED, No. 1051.

\$9.10.

**DEMONSTRATED
POSSIBLE 12**

5 A—11 lb. 12 oz.

48-POINT ORNAMENTED, No. 1051.

\$8.45.

**MASTERFUL
TACT 2**

V. B. MUNSON, SUCCESSOR TO
GEO. BRUCE'S SON & CO., 13 CHAMBERS STREET, NEW YORK.

STYLE 1052.

12 A—2 lb. 6 oz.

18-POINT ORNAMENTED, No. 1052.

\$2.40.

THEN SLOWLY FLUSHED THE DAWN, AND ON
A SUDDEN BURST REVERBERATING
THUNDER, A FLAMING SHELL ROSE 1234

10 A—4 lb.

24-POINT ORNAMENTED, No. 1052.

\$3.60.

SCREAMING TO SEAWARD O'ER
FREEDOM'S CITADEL 123

8 A—6 lb. 4 oz.

36-POINT ORNAMENTED, No. 1052.

\$5.15.

GUNS ANSWERED TILL
THRICE TWIXT 12

5 A—8 lb. 4 oz.

48-POINT ORNAMENTED, No. 1052.

\$5.95.

NOW AND AGAIN
VISIBLE 12

V. B. MUNSON, SUCCESSOR TO
GEO. BRUCE'S SON & CO., 13 CHAMBERS STREET, NEW YORK.

STYLE 1059.

15 A—1 lb. 10 oz.

12-POINT ORNAMENTED, No. 1059.

\$1.90.

**ON WARM SUNNY DAYS, WHEN THE OLD WORLD WENT
WELL, IT WAS MOST COMFORTABLE 1234**

12 A—2 lb. 12 oz.

18-POINT ORNAMENTED, No. 1059.

\$2.75.

**TO BRING THE MATTRESSES FROM THE
CABIN, AND PLACING THEM 123**

10 A—4 lb. 6 oz.

24-POINT ORNAMENTED, No. 1059.

\$3.95.

**ON TOP OF THE DECK-HOUSE
LIE DOWN AND DEVOTE 12**

8 A—9 lb. 8 oz.

36-POINT ORNAMENTED, No. 1059.

\$7.80.

**THE WHOLE TIME TO
BREATHING 12**

5 A—10 lb.

48-POINT ORNAMENTED, No. 1059.

\$7.20.

**IDEAL AUGUST
LOAFING 2**

V. B. MUNSON, SUCCESSOR TO
GEO. BRUCE'S SON & CO., 13 CHAMBERS STREET, NEW YORK.

STYLE 1060.

15 A—2 lb. 14 oz.

12-POINT ORNAMENTED, No. 1060.

\$3.35.

**HERE WE SAW THE DAILY LIFE
OF A LITTLE COMMUNITY 12**

12 A—4 lb.

18-POINT ORNAMENTED, No. 1060.

\$4.00.

**THE LIKE OF WHICH CAN
NOT BE FOUND IN 12**

10 A—6 lb. 8 oz.

24-POINT ORNAMENTED, No. 1060.

\$5.85.

**ANOTHER PART OF
THE WORLD 12**

8 A—13 lb.

36-POINT ORNAMENTED, No. 1060.

\$10.65.

**ONE FOUND A
LOBSTER 2**

5 A—10 lb. 14 oz.

48-POINT ORNAMENTED, No. 1060.

\$7.85.

**RAG-TIME
GALS 3**

V. B. MUNSON, SUCCESSOR TO
GEO. BRUCE'S SON & CO., 13 CHAMBERS STREET, NEW YORK.

STYLE 1067.

12 A—2 lb. 6 oz.

18-POINT ORNAMENTED, No. 1067.

\$2.40.

ALL ITS VOICES SANG A SIREN'S SONG AND
THE MYRIAD FACES OF HILLS AND
LAKES SMILED A GRAD WELCOME 12345

10 A—2 lb. 6 oz.

24-POINT ORNAMENTED, No. 1067.

\$2.15.

IN SUMMER THIS IS GOD'S OWN
LAND OF BEAUTY
LABRADOR WILDERNESS 12

8 A—3 lb. 14 oz.

36-POINT ORNAMENTED, No. 1067.

\$3.20.

BEAUTIES OF NATURE
UNADORNED 123

5 A—8 lb. 6 oz.

48-POINT ORNAMENTED, No. 1067.

\$6.05.

WARBLES IN THE
WOODS 123

V. B. MUNSON, SUCCESSOR TO
GEO. BRUCE'S SON & CO., 13 CHAMBERS STREET, NEW YORK.

STYLE 1068.

20 A—1 lb. 10 oz.

10-POINT ORNAMENTED, No. 1068.

\$2.10.

**HERE IS A BLOOD-STAINED SASH BESIDE A RUSTY SWORD,
WITH A LITTLE WHITE CARD IN WHAT IS 1234**

15 A—1 lb. 14 oz.

12-POINT ORNAMENTED, No. 1068.

\$2.20.

**MOST LIKELY THE DELICATE HANDWRITING OF
SOME WIDOW OR DAUGHTER, WHO 123**

12 A—2 lb. 14 oz.

18-POINT ORNAMENTED, No. 1068.

\$2.85.

**HAS FOR THE FIRST TIME MOVED IT
FROM ITS RESTING-PLACE 123**

10 A—4 lb. 8 oz.

24-POINT ORNAMENTED, No. 1068.

\$4.05.

**OVER THE FAMILY ALTAR
TO ITS PRESENT 123**

8 A—9 lb. 12 oz.

36-POINT ORNAMENTED, No. 1068.

\$8.00.

**PLAGE IN HISTORY
BUILDING 123**

5 A—9 lb. 8 oz.

48-POINT ORNAMENTED, No. 1068.

\$6.85.

TENNESSEE 4

V. B. MUNSON, SUCCESSOR TO
GEO. BRUCE'S SON & CO., 13 CHAMBERS STREET, NEW YORK.

STYLE 1071.

A, V, W AND Y IN THIS SERIES ARE KERNED AT THE SIDES ONE-TWELFTH OF THE BODY, AND ARE ACCOMPANIED BY A SPACE TO USE WHEN THE KERN IS UNNECESSARY.

15 A—2 lb. 6 oz.

12-POINT ORNAMENTED, No. 1071.

\$2.75.

**OVER THE EDGE OF THE FAN GLEAMS
A PAIR OF SOFT EYES,
SPANISH EYES, THOSE THAT 1234**

12 A—4 lb. 4 oz.

18-POINT ORNAMENTED, No. 1071.

\$4.25.

**FLASH OR SWOON AS THE
MOOD STIRS THEIR
LIQUID DEPTHS 123456**

10 A—6 lb. 6 oz.

24-POINT ORNAMENTED, No. 1071.

\$5.75.

**ABOVE THESE IS A
LOW WHITE
FOREHEAD 1234**

8 A—14 lb.

36-POINT ORNAMENTED, No. 1071.

\$11.50.

**AND MASSES
OF RED 12**

V. B. MUNSON, SUCCESSOR TO
GEO. BRUCE'S SON & CO., 13 CHAMBERS STREET, NEW YORK.

STYLE 1073.

A. L. V. W AND Y IN THIS SERIES ARE KEENED AT THE SIDES ONE-TWELFTH OF THE BODY, AND ARE ACCOMPANIED BY A SPACE TO USE WHEN THE KEEN IS UNNECESSARY.

15 A—2 B. 8 oz.

12-POINT ORNAMENTED, No. 1073.

\$2.90.

**SURMOUNTING ALL THIS CHARMING
LOVELINESS--ABOVE THE
MOUTH AND TEETH--ABOVE 123**

12 A—4 B. 6 oz.

18-POINT ORNAMENTED, No. 1073.

\$4.35.

**THOSE SOFT, SEDUCTIVE
EYES--ABOVE THE
FAIR, WHITE THROAT 2**

10 A—6 B. 12 oz.

24-POINT ORNAMENTED, No. 1073.

\$6.10.

**ON TOP THE MASS
OF WAVY
BLACK HAIR 33**

8 A—13 B. 4 oz.

36-POINT ORNAMENTED, No. 1073.

\$10.85.

**IS A MODERN
BONNET 2**

V. B. MUNSON, SUCCESSOR TO
GEO. BRUCE'S SON & CO., 13 CHAMBERS STREET, NEW YORK.

STYLE 1074.

12 A—2 lb. 4 oz.

18-POINT ORNAMENTED, No. 1074.

\$2.25.

A FINE SUNDAY IN CENTRAL PARK

SEPTEMBER, 1901

10 A—3 lb. 12 oz.

24-POINT ORNAMENTED, No. 1074.

\$3.40.

INTERNATIONAL YACHT RACE

OCTOBER, 2000

8 A—6 lb. 2 oz.

36-POINT ORNAMENTED, No. 1074.

\$5.00.

ME AND BOBIE IN 24

A. D. 3000

5 A—7 lb. 14 oz.

48-POINT ORNAMENTED, No. 1074.

\$5.75.

STUYVESANT

1817

V. B. MUNSON, SUCCESSOR TO
GEO. BRUCE'S SON & CO., 13 CHAMBERS STREET, NEW YORK.

STYLE 1075.

15 A—2 lb.

12-POINT ORNAMENTED, No. 1075.

\$2.30.

A SOFT SUMMER BREEZE SHOOK OUT THE
BRIGHT FLAGS AND BANNERS
THE SAILS OF THE MYRIAD CRAFT 123

12 A—3 lb. 6 oz.

18-POINT ORNAMENTED, No. 1075.

\$3.35.

WHICH ROCKED GENTLY ON THE
SUNLIT BOSOM OF THE 123

10 A—4 lb. 14 oz.

24-POINT ORNAMENTED, No. 1075.

\$4.40.

LAND-LOCKED HARBOR
AT OWEN SOUND 12

8 A—10 lb.

36-POINT ORNAMENTED, No. 1075.

\$8.20.

AND THE BANDS
PLAYED ON 12

V. B. MUNSON, SUCCESSOR TO
GEO. BRUCE'S SON & CO., 13 CHAMBERS STREET, NEW YORK.

15 A—2 lb

12-POINT ORNAMENTED, No. 1076.

\$2.30.

**A STRIKING STUDY OF AMERICAN MANNERS,
CUSTOMS AND INSTITUTIONS
FROM A FOREIGNER'S STANDPOINT 1234**

12 A—3 lb. 4 oz.

18-POINT ORNAMENTED, No. 1076.

\$3.25.

**LITERARY ANECDOTES BY AN OLD
PHILADELPHIA EDITOR 1234**

10 A—4 lb. 6 oz.

24-POINT ORNAMENTED, No. 1076.

\$3.95.

**HANDSOME VOLUME WITH
ILLUSTRATIONS 1234**

8 A—9 lb. 4 oz.

36-POINT ORNAMENTED, No. 1076.

\$7.60.

**WORKS OF ARTISTS
IN PASTEL 123**

V. B. MUNSON, SUCCESSOR TO
GEO. BRUCE'S SON & CO., 13 CHAMBERS STREET, NEW YORK.

STYLE 1077.

15 A—2 lb. 6 oz.

12-POINT ORNAMENTED, No. 1077.

\$2.75.

**THE SPECTACLE AS A SPECTACLE
COULD BE APPRECIATED
BY ANYONE, WHETHER 12345**

12 A—4 lb. 2 oz.

18-POINT ORNAMENTED, No. 1077.

\$4.15.

**HE KNEW ITS ORIGIN OR
WAS SIMPLY 123**

10 A—6 lb. 2 oz.

24-POINT ORNAMENTED, No. 1077.

\$5.50.

**INFLUENCED BY A
DESIRE TO 123**

8 A—13 lb.

36-POINT ORNAMENTED, No. 1077.

\$10.65.

**LEND ME SIX
DOLLARS 2**

V. B. MUNSON, SUCCESSOR TO
GEO. BRUCE'S SON & CO., 13 CHAMBERS STREET, NEW YORK.

STYLE 1079.

A—1 lb. 8 oz.

12-POINT ORNAMENTED, No. 1079.

\$1.75.

UPON A FRIGID MORN IN DREARY WINTER CAME A POOR
OLD RED-NOSED PRINTER, WHO WAS
URGENTLY IN NEED OF A SMALL DONATION 1284

12 A—2 lb. 6 oz.

18-POINT ORNAMENTED, No. 1079.

\$2.35.

WITH WHICH TO GRATIFY HIS LONGING FOR
HIS FAVORITE POTATION 1284

10 A—3 lb. 14 oz.

24-POINT ORNAMENTED, No. 1079.

\$3.50.

THE GENTLEMANLY COMPS GAVE
HIM THE MARBLE HEART 123

8 A—5 lb. 14 oz.

36-POINT ORNAMENTED, No. 1079.

\$4.80.

ADVISED HIM TO DEPART
AND TO START 123

5 A—7 lb. 12 oz.

48-POINT ORNAMENTED, No. 1079.

\$5.65.

SANS CEREMONY 1

V. B. MUNSON, SUCCESSOR TO
GEO. BRUCE'S SON & CO., 13 CHAMBERS STREET, NEW YORK.

STYLE 1080.

15 A—1 lb. 6 oz.

12-POINT ORNAMENTED, No. 1080.

\$1.60.

THROUGH SWAMPS AND JUNGLES; AT OTHER TIMES OVER THE
LIMESTONE FORMATION ALONG THE COAST,
WHERE WAVES DASHED AS HIGH AS THE SMOKE-STACK 123

12 A—2 lb. 6 oz.

18-POINT ORNAMENTED, No. 1080.

\$2.35.

COVERING THE EXCURSIONISTS WITH A WHITE
SPRAY, WHILE THOUSANDS OF 1234

10 A—3 lb. 6 oz.

24-POINT ORNAMENTED, No. 1080.

\$3.05.

LAND-CRABS, PAINTED YELLOW AND
BLACK AND RED, SCRAMBLED 123

8 A—6 lb. 14 oz.

36-POINT ORNAMENTED, No. 1080.

\$5.65.

WITH A RATTLE LIKE DEAD
MEN'S BONES 1234

5 A—7 lb. 4 oz.

48-POINT ORNAMENTED, No. 1080.

\$5.20.

ACROSS THE RAILS

V. B. MUNSON, SUCCESSOR TO
GEO. BRUCE'S SON & CO., 13 CHAMBERS STREET, NEW YORK.

STYLE 1081.

15 A—1 lb. 6 oz.

12-POINT ORNAMENTED, No. 1081.

\$1.60.

GREAT LIZARDS RAN FROM SUNNY ROCKS AT SOUND OF THEIR
APPROACH, AND A DEER BOUNDED ACROSS THE
TRACKS FIFTY FEET IN FRONT OF THE COW-CATCHER 1234

12 A—2 lb.

18-POINT ORNAMENTED, No. 1081.

\$2.00.

WE WERE ALL AT THE STATION TO MEET THEM
IN THE WHITEST OF WHITE DUCK 1234

10 A—2 lb. 10 oz.

24-POINT ORNAMENTED, No. 1081.

\$2.35.

AND WITH A BUNCH OF PONIES TO
CARRY THEM ON THEIR 1234

8 A—7 lb.

36-POINT ORNAMENTED, No. 1081.

\$5.75.

TOUR OF INSPECTION OF
THE VILLAGE OF 123

5 A—7 lb. 6 oz.

48-POINT ORNAMENTED, No. 1081.

\$5.30.

SUN-BAKED HUTS 1

V. B. MUNSON, SUCCESSOR TO
GEO. BRUCE'S SON & CO., 13 CHAMBERS STREET, NEW YORK.

STYLE 1082.

15 A—1 lb. 8 oz.

12-POINT ORNAMENTED, No. 1082.

\$1.75.

I WAS OF SUCH LITTLE ACCOUNT THAT I'VE BEEN KNOCKED
THE LENGTH OF THE MAIN DECK AT THE END OF
THE MATE'S FIST AND LEFT TO LIE BLEEDING 1234567

12 A—2 lb. 6 oz.

18-POINT ORNAMENTED, No. 1082.

\$2.35.

I HADN'T A THING TO MY NAME THEN BUT
THE CLOTMES I WORE, AND 1234

10 A—3 lb. 8 oz.

24-POINT ORNAMENTED, No. 1082.

\$3.15.

I'VE BEEN A COWBOY, WITH EIGHT
THOUSAND HEAD OF CATTLE 12

8 A—7 lb.

36-POINT ORNAMENTED, No. 1082.

\$5.75.

AS MY SOLE COMPANIONS
THE WHOLE YEAR 12

V. B. MUNSON, SUCCESSOR TO
GEO. BRUCE'S SON & CO., 13 CHAMBERS STREET, NEW YORK.

STYLE 1084.

15 A—1 lb. 10 oz

12-POINT ORNAMENTED, No. 1084.

\$1.90.

I'VE SAT IN MY SADDLE NIGHT AFTER NIGHT, WITH
NOTHING OVERHEAD BUT THE STARS,
THE NEAREST COCKTAIL 15,000 MILES AWAY 12

12 A—3 lb. 2 oz.

18-POINT ORNAMENTED, No. 1084.

\$3.10.

I'VE FOUGHT ON THE MUD FLOOR OF A
MEXICAN SHACK, WITH A NAKED 12

10 A—4 lb.

24-POINT ORNAMENTED, No. 1084.

\$3.60.

DAGGER IN MY HAND, FOR MY
LAST DOLLAR 1234

8 A—8 lb.

36-POINT ORNAMENTED, No. 1084.

\$6.55.

DARED THE BOWERY
WITH ALL MY 12

5 A—9 lb.

48-POINT ORNAMENTED, No. 1084.

\$6.50.

JEWELRY ON 4

V. B. MUNSON, SUCCESSOR TO
GEO. BRUCE'S SON & CO., 13 CHAMBERS STREET, NEW YORK.

STYLE 1087.

15 A—2 lb. 10 oz.

12-POINT ORNAMENTED, No. 1087.

\$3.05.

SOFT AS A ROSE-LEAF THAT THE
WEST WINDS PRAY 1234

12 A—4 lb. 2 oz.

18-POINT ORNAMENTED, No. 1087.

\$4.10.

THE SPLENDID GLORY OF
THE EVENING SKY 123

10 A—6 lb. 10 oz.

24-POINT ORNAMENTED, No. 1087.

\$5.95.

HILLS RADIANT IN
CRIMSON 123

8 A—11 lb. 6 oz.

36-POINT ORNAMENTED, No. 1087.

\$9.35.

PURPLE, AND
GOLD 123

5 A—14 lb. 10 oz.

48-POINT ORNAMENTED, No. 1087.

\$10.55.

VBRITAS
YUM 2

V. B. MUNSON, SUCCESSOR TO
GEO. BRUCE'S SON & CO., 13 CHAMBERS STREET, NEW YORK.

STYLE 1088.

15 A—2 lb. 2 oz.

12-POINT ORNAMENTED, No. 1088.

\$2.45.

**GAZING AT THE SUNLIT SEA, ROCKING LIKE
A BOWL OF MOLTEN GOLD 1234**

12 A—3 lb. 10 oz.

18-POINT ORNAMENTED, No. 1088.

\$3.60.

**FROM THE LOFTY, RAGGED CLIFFS
TO THE HORIZON 1234**

12 A—5 lb. 8 oz.

22-POINT ORNAMENTED, No. 1088.

\$4.95.

**ON A GLISTENING PEAK,
SILHOUETTED 123**

8 A—10 lb. 2 oz.

36-POINT ORNAMENTED, No. 1088.

\$8.30.

**AGAINST BLAZE
OF SEA 123**

5 A—11 lb.

48-POINT ORNAMENTED, No. 1088.

\$7.90.

**A BUZZARD
SAT 12**

V. B. MUNSON, SUCCESSOR TO
GEO. BRUCE'S SON & CO., 13 CHAMBERS STREET, NEW YORK.

STYLE 1089.

15 A—1 lb.

12-POINT ORNAMENTED, No. 1089.

\$1.15.

FROM THE HIGH CLIFF, ON WHICH THE PALMS STOOD, THEY COULD LOOK UP AND DOWN
THE NARROW INLET THAT JOINED THE OCEAN AND SEE THE MOONLIGHT 1234

12 A—1 lb. 6 oz.

18-POINT ORNAMENTED, No. 1089.

\$1.35.

TURNING THE WATER INTO A RIPPLING LADDER OF LIGHT AND GILDING
THE DARK GREEN LEAVES OF THE WIDE-SPREADING PALMS 1235

10 A—2 lb.

24-POINT ORNAMENTED, No. 1089.

\$1.80.

DIRECTLY BELOW THEM LAY THE WATERS OF THE BAY,
REFLECTING THE RED AND GREEN LIGHTS OF 123

8 A—3 lb. 2 oz.

36-POINT ORNAMENTED, No. 1089.

\$2.55.

SHIPS AT ANCHOR, AND BEYOND THEM THE
YELLOW LIGHTS OF THE TOWN 12345

5 A—3 lb. 12 oz.

48-POINT ORNAMENTED, No. 1089.

\$2.70.

BLINKED THROUGH THE QUICKLY
GATHERING GLOOM 12345

V. B. MUNSON, SUCCESSOR TO
GEO. BRUCE'S SON & CO., 13 CHAMBERS STREET, NEW YORK.

STYLE 1090.

15 A—1 lb. 14 oz.

12-POINT ORNAMENTED, No. 1090.

\$2.15.

**IN THE NARROW STREETS WERE COWBOYS AND
BARE-LEGGED MULE-DRIVERS, AND 1234**

12 A—2 lb. 14 oz.

18-POINT ORNAMENTED, No. 1090.

\$2.90.

**VERY RAGGED RANCHMEN WITH RED
CAPED CLOAKS HANGING 1234**

10 A—4 lb. 4 oz.

24-POINT ORNAMENTED, No. 1090.

\$3.80.

**NEARLY TO THEIR MUDDY
SANDALS 123456**

8 A—10 lb. 4 oz.

36-POINT ORNAMENTED, No. 1090.

\$8.40.

**CHARMING NEGRO
WOMEN 1234**

5 A—10 lb.

48-POINT ORNAMENTED, No. 1090.

\$7.20.

**WITH LARGE
MOUTHS 3**

V. B. MUNSON, SUCCESSOR TO
GEO. BRUCE'S SON & CO., 13 CHAMBERS STREET, NEW YORK.

STYLE 1091.

15 A—1 lb. 12 oz.

12-POINT ORNAMENTED, No. 1091.

\$2.05.

EVEN WITHOUT THE HAWKS THE JAYS ALWAYS
HAD A CAUSE OF COMPLAINT 123456

12 A—2 lb. 14 oz.

18-POINT ORNAMENTED, No. 1091.

\$2.90.

BESIDES FREQUENT BATTLES WITH
THE WOODPECKERS 1234

10 A—4 lb. 8 oz.

24-POINT ORNAMENTED, No. 1091.

\$4.05.

THEY CONTRIVED TO GET
UP A NOTABLE 1234

8 A—9 lb.

36-POINT ORNAMENTED, No. 1091.

\$7.40.

WITH THE FLYING
SQUIRRELS 123

5 A—9 lb. 8 oz.

48-POINT ORNAMENTED, No. 1091.

\$6.85.

BALMY JUNE,
A. D. 1989

V. B. MUNSON, SUCCESSOR TO
GEO. BRUCE'S SON & CO., 13 CHAMBERS STREET, NEW YORK.

STYLE 1092.

15 A—1 lb. 10 oz.

12-POINT ORNAMENTED, No. 1092.

\$1.90.

THE GREAT SQUARE IN WHICH THE EVOLUTIONS WERE
TO TAKE PLACE WAS LINED ON ITS FOUR SIDES 123

12 A—3 lb.

18-POINT ORNAMENTED, No. 1092.

\$3.00.

BY THE CARRIAGES OF THE WEALTHY,
EXCEPT AT THE TWO GATES 123

10 A—4 lb. 4 oz.

24-POINT ORNAMENTED, No. 1092.

\$3.85.

WHERE A WIDE SPACE WAS
LEFT OPEN TO 123

8 A—7 lb. 10 oz.

36-POINT ORNAMENTED, No. 1092.

\$6.25.

ADMIT THE CROWD
OF SAVAGES 123

5 A—8 lb. 12 oz.

48-POINT ORNAMENTED, No. 1092.

\$6.30.

THREATENING
THE GATE 4

V. B. MUNSON, SUCCESSOR TO
GEO. BRUCE'S SON & CO., 13 CHAMBERS STREET, NEW YORK.

STYLE 1505.

25 a 12 A 6 lb. 14 oz.

22-POINT ORNAMENTED, No. 1505.

\$6.20.

IN THANKFUL APPRECIATION
OF THE MANY KINDNESSES AND REPEATED GIFTS
RECEIVED AT THE HANDS OF
THE PRINTERS OF THE UNITED STATES,
CANADA AND EUROPE

20 a 10 A—8 lb. 6 oz.

28-POINT ORNAMENTED, No. 1505.

\$7.20.

THIS TOURIST'S MEDICINE CHEST
CAPACITY ONE QUART
IS RESPECTFULLY BEQUEATHED TO THE
FELLOW TOURIST

15 a 8 A—12 lb. 4 oz.

36-POINT ORNAMENTED, No. 1505.

\$10.05.

WHOSE APPRECIATION OF THIS
HONOR MOVES HIM TO
INVEST AT LEAST A HALF

V. B. MUNSON, SUCCESSOR TO
GEO. BRUCE'S SON & CO., 13 CHAMBERS STREET, NEW YORK.

STYLES 1506 AND 1507.

30 a 15 A—3 lb. 12-POINT ORNAMENTED, No. 1506. \$3.50.

AS WE ROWED FROM ONE LAKE INTO THE NEXT
We would come unexpectedly upon sheltered coves where the clear,
green water slipped over a sandy bottom 1234567890

25 a 12 A—4 lb. 12 oz. 18-POINT ORNAMENTED, No. 1506. \$4.75.

AS HARD AND SMOOTH AS ASPHALT,
And then we would row frantically back to camp
for our bathing suits to try it 1234567

20 a 10 A—7 lb. 24-POINT ORNAMENTED, No. 1506. \$6.30.

ONCE WE WERE REWARDED
By finding fresh prints of an antelope 12

30 a 15 A—3 lb. 12 oz. 12-POINT ORNAMENTED, No. 1507. \$4.35.

THERE WERE NIGHTS WHEN WE WOULD GO
Out in the canoe and float as far into the chain of lakes
as we dared, with only the far-off 1234567

25 a 12 A—6 lb. 8 oz. 18-POINT ORNAMENTED, No. 1507. \$6.50.

CRY OF A LOON OR THE SOFT
Whirr of a wild turkey, as it scurried
low across the water 123456

20 a 10 A—9 lb. 2 oz. 24-POINT ORNAMENTED, No. 1507. \$8.20.

THAT WAS IN JANUARY
When the ice is ten feet thick 23

V. B. MUNSON, SUCCESSOR TO
GEO. BRUCE'S SON & CO., 13 CHAMBERS STREET, NEW YORK.

STYLE 1508.

30 A—1 lb.

6-POINT ORNAMENTED, No. 1508.

\$2.00.

THERE IS A DREAMY HEAT AND QUIET ABOUT THIS SORT OF HAPPY LOTUS
LAND, A DELICIOUS SENSE OF UTTER SOLITUDE, AND A
GLIMPSE OF A HAPPY EXISTENCE INDEPENDENT OF MOST OF THE
THINGS WHICH ONE USUALLY CONSIDERS ESSENTIAL TO HAPPINESS

40 a 20 A—3 lb. 8 oz.

10-POINT ORNAMENTED, No. 1508.

\$4.55.

FROM THAT PLACE THE WORLD AND ALL ITS
Pleasures seemed as far off as though one were looking at them
through the wrong end of an opera glass 12345678

30 a 15 A—4 lb. 4 oz.

12-POINT ORNAMENTED, No. 1508.

\$4.95.

THE FEELING BEGAN TO GROW UPON US
At the outset of the long, lazy journey, when we
drove straight west over the prairie 123

25 a 12 A—8 lb.

20-POINT ORNAMENTED, No. 1508.

\$7.50.

WITH THE HORSES GOING
In their steady, easy trot, the trap
swaying gently on the 123

20 a 10 A—10 lb. 8 oz.

24-POINT ORNAMENTED, No. 1508.

\$9.45.

SOFT PRAIRIE GRASS
And a misty mountain peak
in the distance 123

V. B. MUNSON, SUCCESSOR TO
GEO. BRUCE'S SON & CO., 13 CHAMBERS STREET, NEW YORK.

STYLE 1509.

30 a 15 A—4 lb. 12 oz.

12-POINT ORNAMENTED, No. 1509.

\$5.50.

THE WEATHER GREW ROUGH EARLY
In that September, and all at once, in a
moment, as it were, the pretty
watering-place lost 123

30 a 15 A—7 lb. 4 oz.

16-POINT ORNAMENTED, No. 1509.

\$7.70.

ITS AIR OF SUMMER GAYETY
The sea looked cold. A few of the
more hardy bathers 123

25 a 12 A—8 lb. 12 oz.

20-POINT ORNAMENTED, No. 1509.

\$8.20.

BRAVED IT ON SELECT
Days in the surf, but they had
become purple 12

20 a 10 A—11 lb. 4 oz.

24-POINT ORNAMENTED, No. 1509.

\$10.10.

WHEN THEY RAN
Up to the bath-houses
in such a shiver

V. B. MUNSON, SUCCESSOR TO
GEO. BRUCE'S SON & CO., 13 CHAMBERS STREET, NEW YORK.

JENSON OLD STYLE

72 POINT

4 A 5 a \$17 00

ROMANS
Grand pieces
third year 25

60 POINT

4 A 5 a \$12 25

FOUNDERS
Original model
artistic faces 13

JENSON OLD STYLE



54 POINT

4 A 5 a \$10 25

ORIGINAL
English founders
cast Diamond as
far back as 1700

48 POINT

4 A 5 a \$7 75

DESIGNING
The date at which
we quit the survey
is not glorious.  

JENSON OLD STYLE

42 POINT

4 A 6 a \$7 25

DARING RIDERS
Surge over the plains
beyond 36 castles. 

36 POINT

5 A 8 a \$5 50

SINGLE 25 JUSTICE
Full of healthy sense and
inspiration for all nations

30 POINT

6 A 10 a \$5 00

DEMAND FOR UNIQUE
Effects which surprise the eye
and amaze the brain cost less
in the end than ordinary 780

JENSON OLD STYLE

24 POINT

10A 15a \$4 50

PRICES BASED ON FIGURES

The check to uncertain estimating is in keeping a record of every item of expense that enters into the work and comparing it with the estimate when the job is completed. It is the only practical method of arriving at tangible facts on which to base the cost of your own productions 47 

18 POINT

12A 20a \$4 00

ENLIGHTEN HONEST CUSTOMERS

In one particular it is always wise to enlighten every patron in order to reach a basis of mutual understanding when contracts are made. Most people are more or less ignorant of the customs and terms of the trade. This ignorance leads to much disputing and rankling dissatisfaction on the part of customers. Well-meaning and honest though they are, it is difficult for them to understand why the bill should be \$329 

JENSON OLD STYLE

14 POINT

15 A 25 a \$3 50

ON THE PROGRESS IN MACHINERY AND THE MAKING OF NEW TYPE FACES.***



IN 1835 I saw for the first time the printing house of Harper & Brothers. With childish awe I watched the flutter of the friskets of a dozen hand presses, and the slow but steady piling-up of printed sheets on the bank. Could any machines be finer or better? So I thought, and so Harper & Brothers thought; but in a few years the hand presses were supplanted by the Adams. This change was but the beginning of a series of changes that I can sketch in outline only. The two-roller Adams of wood frame was followed by the four-roller machine of iron frame and \$4295

12 POINT

18 A 30 a \$3 25

MODERN VERSION OF THE WORLD OLD STORY OF MAKING BRICKS WITHOUT STRAW.***



WHEN we discover here and there a printer wasting his energies and abilities in the vain endeavor to execute printing to the satisfaction of his clients with type lacking in originality, in art, and devoid of the life that can only be imparted by a genius in designing, we are reminded of the cruel task allotted to the Hebrews by the old Egyptians. There is neither profit nor pleasure in trying to impart an artistic effect with in-artistic type. It is a question whether the durability of such type is not an added injury to the unfortunate printer who uses it. Pound for pound the type of the American Type Founders Co. costs no more than type unenlivened by artistic merit; but in its true value it surpasses all other type as the masterpieces £376

JENSON OLD STYLE

10 POINT

25 A 30 a \$3 00

HE HAS DEMANDS FOR FACES BOLD AND BLACK, LIGHT AND SKINNY, BROAD, CONDENSED, LARGE



MALL, with long ceriphs, with short ceriphs, with high ascenders, with short descenders, and other mannerisms too tedious to describe. We are asked to get these in fonts of thousands of pounds, but to buy half of them, or quarter of them, is to invite bankruptcy. There are publishers who ask that thousands of pages be kept standing for months. There are men before me who have sent, and are sending, proofs to Europe, and even to the Pacific Islands, and Asia. A prominent printer of Paris told me that the weight of the book types in his house largely exceeded two million pounds. The tied-up pages piled up like bricks on every floor of the house was proof of the statement. Fifty years ago a book and job printer could keep sixty compositors at work on a plant of types and appurtenances that cost less than \$10,000.

6 POINT

35 A 50 a \$2 50

A GOOD FEATURE IN PREVAILING FASHIONS IS THE GENERAL DISLIKE FOR ALL ORNAMENTAL AND FRAIL TYPES.

WHEN Whittinghouse of London revived the trade for old style letter, in 1844, the old order changed. Not liked at all in the beginning, old style slowly grew in favor, especially with those who wished to give distinction to their work. Before 1860 it was required of every prosperous book and job printer that he should have a full series of old style faces, complete from Pearl to Canon. This compelled a doubling of the expense of equipping the composing room; but if the demand for novelty had stopped here, this added expense might not need any notice. But it did not stop with the modernized old style. Think of the varieties now offered to us by the type founders—Caslon, Franklin, Barth, Binny, Ronaldson, Cadmus or Elzevir, French, Jenson, etc. Nor is this all: other faces with peculiar mannerisms are made abroad, and there are publishers who will have them. Standard or modern-cut Roman is provided by type founders in greater variety. The book printer who has two faces only in series soon finds them insufficient. He has demands for others.

8 POINT

25 A 35 a \$2 75

THE MANUFACTURERS OF OUR MACHINES ASSURED US AGAIN AND AGAIN THAT THEIR LAST MACHINES WERE PERFECTION.



IT was not possible to make anything better; they would meet every demand for strength, speed, accuracy, and ease of handling. So they did for a time; but in a few years on came the improvements, once declared impossible, and in the form of larger and more efficient machines. The presses that were the best of their kind in 1865 proved too small and too slow in 1875. To continue to use them would be to do work at cost or at loss. When one has room enough, the old machines may be set aside and put to an inferior class of presswork. But when rents are high and space is contracted the old machines must be sold. What do we get for old presses? It often happens that after only seven or ten years of service, the press that cost \$3000 or \$5000 will be sold for from \$300 to \$600. It is not worn out, it may be in good condition, and should be efficient for twenty years more, but it must be sold because it is not up to present needs. It will not pay to keep it when your rival is using new machines.

JENSON ITALIC

72 POINT

4 A 5 a \$17 00

Our Reports
were valued
SECURE

60 POINT

4 A 5 a \$12 25

Roman Letters
were invented
MODERN

JENSON ITALIC

54 POINT

4A 5a 810 25

*German printers
used bold Black
Type which was
PRINTED*

48 POINT

4A 5a 87 75

*In early history the
first type Printers
in the Monasteries
RECEIVED*

JENSON ITALIC

42 POINT

4A 6a 87 25

*Italic type is claimed
by historians to be a
good imitation of the
writings of Petrarch*
HISTORICAL

36 POINT

4A 8a 85 50

*The honor of introducing
Italic has been bestowed
on Aldus Manutius, who
used it in classical works*
INTRODUCTION

For Jenson Italic ornamental lower-case, see page 240^b

JENSON ITALIC

30 POINT

5 A 10 a \$5 00

The original Italic letter was called Venetian or Aldine and was defaced by very strange irregularities in the formation of the slope of the characters

MALFORMATIONS

24 POINT

6 A 15 a \$4 50

Astonishing strides in the designing of Italic type have been made in the last few years. The improvements made in their beauty and the general up-to-date style of their characters reflect a high degree of superiority on the skill of the modern designer

ADVANCEMENTS

*For Jenson Italic ornamental lower-case, see page 240**

BRUCE TYPE FOUNDRY, 13 CHAMBERS STREET, NEW YORK.

JENSON ITALIC

18 POINT

10 A 25 a \$4 00

Jenson Italic as a display type is a decided novelty. It is distinct in style and striking in character. It is made to the same line as the Jenson Old Style, and its value as a companion letter will be appreciated by printer and advertiser

CHARACTERS

12 POINT

18 A 40 a \$3 25

Makers of Advertisements who formerly recommended the use of old style letters to their clientele will recognize in the Jenson Italic a monotony-breaking substitute, and the reading public will see it and be impressively attracted by advertisements set in this modest and character-giving letter. The aim of writers of advertisements is naturally to attract business to themselves, and that can only be done by attracting the great mass of readers to those who advertise

MAKING PROFITS

PARTICULAR ATTENTION IS DIRECTED TO THE BEAUTY OF THE CAP LINES IN THIS SERIES

The Jenson Italic

Ornamental lower-case letters are intended to be used exclusively as final letters. To get the very best results they should be used sparingly in all classes of work. One or two letters properly placed in a job will add to its attractiveness.

The Jenson Italic

*Ornamental lower-case letters are made in three characters *n g y* and are cast in all the sizes from 12 Point to 72 Point.*

The Jenson Italic

Ornamental lower-case characters are not put up with regular fonts, as all fonts are complete without them. They are furnished at the following prices per font:

12 POINT, 18 POINT AND 24 POINT
EACH 50 CENTS

30 POINT, 36 POINT, 42 POINT, 48 POINT
EACH 75 CENTS

54 POINT, 60 POINT AND 72 POINT
EACH \$1 00

JENSON ITALIC

10 POINT

20 A 45 a \$3 00

THE type made by the American Type Founders' Company is conceded by expert printers to outrank all competitors in its beauty of design, style of finish, and admirable wearing qualities. These three cardinal features are, in themselves, sufficient to recommend them to the vast army of purchasing printers and magazine publishers as a money-saving investment

O Leon, my lover,
Why should you despair,
When Love comes unbidden
With wreaths in his hair?
I love you, my Mona,
Is easy to say
As bird on the tree-top
To sing out his lay.

POINTS TO CONSIDER

8 POINT

20 A 50 a \$2 75

JENSON TYPE.

In Jenson type my printer knows
The height of typographic pose;
The black-faced letters cross the page
Like mummings of some by-gone age
In solemn, sad, funereal rows.

No matter what is said, "it goes,"
Though doggerel verse—puerile prose—
If but its wretched rantings rage
In Jenson type.

Go, foolish rhyme, and dress your woes
In this prevailing garb of those
Who call all well that fits the gauge
Set by the medieval sage—
You too, may conquer, I suppose,
In Jenson type.

NOW to the point that pinches mankind the hardest—the unloosening of the purse-string—and has been the subject of frequent discussions for time immemorial. In figuring on the cost of new type do you regard it as an unnecessary expense or in the light of a good investment to buy the best? If as an investment, suppose a first-class, distinctive style of type costs you a little more than the ordinary and less attractive design, but the returns from the former are double the returns from the latter, which one would you select? You won't hesitate to choose that which is the most profitable.

ARGUMENT AND EXPLANATION

8 POINT

20 A 50 a \$2 50

EVERYTHING that is required in a printing office, from a pair of tweezers to a perfecting press (to say nothing of type) can be supplied on the shortest notice by any Branch House of the American Type Founders' Company. These Branches are all conveniently located throughout the United States for the benefit of the trade and to facilitate the work of supplying the demands made upon us by an appreciative and increasing patronage. Therefore, place your orders with Branch nearest your place of business to insure promptness. A printing office completely supplied with the products of our manufacture is worth far more for use or sale than one made up from the productions of incomplete type foundries.

INFORMATION FOR THE ENTERPRISING

1234567890

O Mona, you tease me,
And vex me for aye;
But, Mona, I love you,
Shall love you alway;
I would to the altar
Now lead you a bride,
But love makes me falter
And sway with the tide.

Then bye, oh bye, darling,
For Mona must part
From Leon her lover
With dread in his heart;
Your love is the dewdrop
That dies in the sun,
Good-by, and forever,
With Mona unwon!

BRUCE TYPE FOUNDRY, 13 CHAMBERS STREET, NEW YORK.

JENSON HEAVYFACE

120 POINT

3 A 4 a \$22 50

FINE

Brake

60 POINT

4 A 5 a \$12 25

BANGLLED

**Designed for
work of 1899**

JENSON HEAVYFACE

96 POINT

3 A 4 a \$19 00

BRICK

Strikers

72 POINT

4 A 5 a \$17 00

SPREAD

Duty Bold

Plants \$2

JENSON HEAVYFACE

48 POINT

4 A 5 a \$7 75

NEW SERIES
Bright Method
Plain 48 Guide

36 POINT

5 A 8 a \$5 50

PRIOR NOTICE
Liberal 56 Patron
Enjoy Clear Strong

30 POINT

6 A 10 a \$5 00

CONVEY MEANING
As necessary for Jenson
Old Style as boldface is
for ordinary romans 73

JENSON HEAVYFACE

24 POINT

10 A 15 a \$4 50

REWARD FOR BEST LINE EDUCATED CUSTOMERS

Appreciate Progressive Printers
Investing in 53 Modern Letters
Substantial Harvest Gathering

18 POINT

12 A 20 a \$4 00

TRADESMENS MODEST PRAISE IS MERITED IN EVERY RESPECT

Every printer should include this series of
Jenson Heavyface in stock for regular use.
Clear-cut characters with a style that will
look well, cast in metal that will wear long

12 POINT

18 A 30 a \$3 25

DEMAND FOR JENSON HEAVYFACE IS POSITIVE PROOF OF ITS POPULARITY WITH THE CRAFT

A strikingly handsome and impressive clean cut face made
complete with Figures in 10 well graded sizes, is especially
adapted for use with the Jenson Old Style and is receiving
generous and merited praise from printers of every section.
It has become one of the most popular of our recent products

STYLE 1511.

30 a 15 A—2 lb. 2 oz.

12-POINT ORNAMENTED, No. 1511.

\$2.45.

BARGES WENT AWAY LADEN TO THE STATIONS AND CAME BACK EMPTY
Except at night, when they brought over the few and fewer husbands whose wives were
staying down simply because they hated to go up and begin
the social life of the winter 1234567890

25 a 12 A—3 lb. 10 oz.

20-POINT ORNAMENTED, No. 1511.

\$3.40.

THE PEOPLE WHO HAD THROGGED THE GRASS-BORDERED
Paths of the village dwindled in number; the riding and driving on
the roads was less and less; the native life showed itself
more in the sparsity of the sojourners 1234567890

20 a 10 A—4 lb. 6 oz.

24-POINT ORNAMENTED, No. 1511.

\$3.95.

THE SWEET WILD FERN IN THE OPEN FIELDS
And the bugs and blackberry vines among the bowlders,
were blighted with the cold wind 1234567890

15 a 8 A—8 lb.

36-POINT ORNAMENTED, No. 1511.

\$6.55.

EVEN THE SWAYING SEA-WEED
At the foot of the rocks seemed to feel a
sharper chill than of the brine 1234

V. B. MUNSON, SUCCESSOR TO
GEO. BRUCE'S SON & CO., 13 CHAMBERS STREET, NEW YORK.

STYLE 1512.

60 a 30 A—2 lb. 4 oz.

6-POINT ORNAMENTED, No. 1512.

\$4.50.

THERE IS SOMETHING IN A MIDNIGHT FIRE THAT PRICKS THE NERVES
It may be the contrast between the quiet streets outside, with the dim stores, the shrouded
counters, the shadows of the tall facades on the roadway, the
white porcupines of light 1234567890

60 a 30 A—3 lb. 12 oz.

8-POINT ORNAMENTED, No. 1512.

\$6.00.

BLINKING AND WINKING IN THE DARK, VIOLET AIR
And the seething excitement that waits around the corner. Or it may
be that the touch of pathos in human calamity
and the touch of horror in 12345

30 a 15 A—4 lb.

12-POINT ORNAMENTED, No. 1512.

\$4.65.

HUMAN PERIL BLEND WITH SHUDDERING
Appreciation of the pageantry of the sight. The
meanest structure flaming in the night
borrows a sinister beauty 123

25 a 12 A—6 lb. 4 oz.

18-POINT ORNAMENTED, No. 1512.

\$6.25.

AND MORE THAN ANYTHING IT
May be that fire-bells, especially in the
unguarded hour of darkness 123

20 a 10 A—10 lb. 4 oz.

24-POINT ORNAMENTED, No. 1512.

\$9.25.

STARTLE THE SENSES
With the sympathy of the
common dread 123

V. B. MUNSON, SUCCESSOR TO
GEO. BRUCE'S SON & CO., 13 CHAMBERS STREET, NEW YORK.

STYLE 1513.

15 a 15 A—3 lb. 8 oz.

12-POINT ORNAMENTED, No. 1513.

\$4.05.

**SHE'S SMILING SOFTLY TO HER-
Self, scarce moving in the morning sun; small
heed hath she of her gentle kine 123**

12 a 12 A—7 lb.

20-POINT ORNAMENTED, No. 1513.

\$6.60.

**JAVOTTE, MIGNONNE
Feeding daintily on the short
sweet meadow grass 123**

10 a 10 A—9 lb. 2 oz.

24-POINT ORNAMENTED, No. 1513.

\$8.20.

**THE COW-GIRL
Stands in the sunlight 2**

8 a 8 A—18 lb. 4 oz.

36-POINT ORNAMENTED, No. 1513.

\$14.95.

**TRANQUIL
Hours at home 2**

5 a 5 A—20 lb. 8 oz.

48-POINT ORNAMENTED, No. 1513.

\$14.75.

SAN Juan 2

V. B. MUNSON, SUCCESSOR TO
GEO. BRUCE'S SON & CO., 13 CHAMBERS STREET, NEW YORK.

STYLE 1514.

15 a 15 A—4 lb.

12-POINT ORNAMENTED, No. 1514.

\$4.65.

**O, LET ME COOL MY ACHING
Brow, the maiden murmured, and the
rain, descending from the 123 V**

15 a 15 A—8 lb.

16-POINT ORNAMENTED, No. 1514.

\$8.50.

**PASSING CLOUDS
Began to patter on the pain
Let it patter 123**

12 a 12 A—11 lb. 10 oz.

22-POINT ORNAMENTED, No. 1514.

\$10.45.

**PANORAMA
Prominent persons
pictured 123**

10 A—10 lb. 2 oz.

28-POINT ORNAMENTED, No. 1514.

\$8.70.

PERFECTLY 4

8 A—12 lb. 14 oz.

36-POINT ORNAMENTED, No. 1514.

\$10.55.

AMERICA 3

V. B. MUNSON, SUCCESSOR TO
GEO. BRUCE'S SON & CO., 13 CHAMBERS STREET, NEW YORK.

STYLE 1515.

20 a 20 A—4 lb. 2 oz. 10-POINT ORNAMENTED, No. 1515. \$5.35.

THERE WERE SUDDEN PARTINGS
That press the life from out young hearts 12

15 a 15 A—4 lb. 10 oz. 12-POINT ORNAMENTED, No. 1515. \$5.35.

AND CHOKING SIGHS
Which ne'er might be repeated 12

12 a 12 A—7 lb. 18-POINT ORNAMENTED, No. 1515. \$7.00.

SONGS THAT WOKE
The echoes of the forest 12

10 a 10 A—11 lb. 4 oz. 24-POINT ORNAMENTED, No. 1515. \$10.15.

MECHANICAL
Genius rewarded 2

8 a 8 A—20 lb. 6 oz. 36-POINT ORNAMENTED, No. 1515. \$16.70.

IMMUNE
Blue jackets 2

5 a 5 A—24 lb. 48-POINT ORNAMENTED, No. 1515. \$17.30.

HONest 2

V. B. MUNSON, SUCCESSOR TO
GEO. BRUCE'S SON & CO., 13 CHAMBERS STREET, NEW YORK.

STYLE 1519.

15 a 15 A—4 lb.

12-POINT ORNAMENTED, No. 1519.

\$4.65.

WEARING A VERY TALL
Well-worn silk hat, and clothed in a
rusty black suit of clerical
cut, the whole figure appeared 123

12 a 12 A—6 lb. 8 oz.

18-POINT ORNAMENTED, No. 1519.

\$6.50.

LIKE A TRAVELLING
Silhouette, the simile being
still further carried 12

10 a 10 A—10 lb.

24-POINT ORNAMENTED, No. 1519.

\$9.00.

OUT BY THE
Black army saddled
broncho 12

8 a 8 A—19 lb. 12 oz.

36-POINT ORNAMENTED, No. 1519.

\$16.20.

PICTURES
Of life on the
frontier 12

V. B. MUNSON, SUCCESSOR TO
GEO. BRUCE'S SON & CO., 13 CHAMBERS STREET, NEW YORK.

STYLE 1522.

15 a 15 A—6 lb.

12-POINT ORNAMENTED, No. 1522.

\$6.95.

IN ALL THE WORLD
There is no highway so
beautiful,
None so shaded 12

10 a 10 A—9 lb, 12 oz.

18-POINT ORNAMENTED, No. 1522.

\$9.75.

WINDS ALONG
The banks of the
Wabash 13

6 a 6 A—10 lb, 10 oz.

24-POINT ORNAMENTED, No. 1522.

\$9.55.

SMELLS
Of fresh cut
hay 12

4 a 4 A—16 lb.

36-POINT ORNAMENTED, No. 1522.

\$13.10.

GIRLS
Amazon
Act 2

V. B. MUNSON, SUCCESSOR TO
GEO. BRUCE'S SON & CO., 13 CHAMBERS STREET, NEW YORK.

STYLE 1525.

30 a 15 A—3 lb. 8 oz. 12-POINT ORNAMENTED, No. 1525. \$4.05.

THE SUDDEN TEMPEST OF ACCLAMATION
And the frantic fluttering of innumerable garments in
the air, startled the spirited horses 123456

25 a 12 A—6 lb. 2 oz. 18-POINT ORNAMENTED, No. 1525. \$6.10.

THEY DASHED MADLY AWAY
And plunged upon the bits, when the left
rein parted at the bridle 136

20 a 10 A—8 lb. 10 oz. 24-POINT ORNAMENTED, No. 1525. \$7.65.

SWUNG TO THE RIGHT
Dashing chariot to atoms 136

15 a 8 A—15 lb. 12 oz. 36-POINT ORNAMENTED, No. 1525. \$12.90.

HUMAN INSECTS
Parasites, flatterers 3

5 a 5 A—14 lb. 2 oz. 48-POINT ORNAMENTED, No. 1525. \$10.15.

DEAD soldier 9

V. B. MUNSON, SUCCESSOR TO
GEO. BRUCE'S SON & CO., 13 CHAMBERS STREET, NEW YORK.

STYLE 1526.

30 & 15 A—3 lb. 2 oz.

12-POINT ORNAMENTED, No. 1526.

\$3.60.

THE WHOLE NEIGHBORHOOD FOR MILES
Around had been familiar to my early youth, and was still dear to
memory. Riding along the well-known 1234

25 & 12 A—5 lb. 6 oz.

18-POINT ORNAMENTED, No. 1526.

\$5.40.

ROAD LEADING INTO THE TOWN
From the south I conjured up the brilliant and
imposing spectacle presented by 123

20 & 10 A—8 lb.

24-POINT ORNAMENTED, No. 1526.

\$7.20.

THE SUPERB FIRE-HALL
The location of which, midway 16

15 & 8 A—13 lb.

36-POINT ORNAMENTED, No. 1526.

\$10.65.

UP A LONG HILL
Reduces to a minimum 9

5 & 5 A—13 lb. 4 oz.

48-POINT ORNAMENTED, No. 1526.

\$9.55.

HOPPE of saving 9

V. B. MUNSON, SUCCESSOR TO
GEO. BRUCE'S SON & CO., 13 CHAMBERS STREET, NEW YORK.

STYLE 1527.

30 a 15 A—3 lb. 6 oz. 12-POINT ORNAMENTED, No. 1527. \$3.90.

*FAR UP IN THE MOUNTAINS, HUNDREDS
Of miles from any habitation, we live the healthful life of a
lumber camp, working from 1234567890*

25 a 12 A—5 lb. 6 oz. 18-POINT ORNAMENTED, No. 1527. \$5.40.

*STARLIGHT TO STARLIGHT
Breathing the pure mountain air, keen with
the frosty vigor of autumn 169*

20 a 10 A—8 lb. 8 oz. 24-POINT ORNAMENTED, No. 1527. \$7.65.

*EATING RAVENOUSLY
The plain, well-cooked food which
is prepared for us and 169*

15 a 8 A—14 lb. 14 oz. 36-POINT ORNAMENTED, No. 1527. \$12.20.

*EATEN IN CAMP
Or on the mountain side 9*

5 a 5 A—14 lb. 48-POINT ORNAMENTED, No. 1527. \$10.10.

GREAT Scott 9

V. B. MUNSON, SUCCESSOR TO
GEO. BRUCE'S SON & CO., 13 CHAMBERS STREET, NEW YORK.

STYLE 1528.

30 a 15 A—3 lb. 12 oz. 12-POINT ORNAMENTED, No. 1528. \$4.35.

AN OLD UNUSED PLANK ROAD LED THROUGH
A mountain pass and along the course of a partially
dry stream far into the interior 12345

25 a 12 A—5 lb. 12 oz. 18-POINT ORNAMENTED, No. 1528. \$5.75.

MOUNTAINS STRIPPED OF TIMBER
Now standing ragged and uncouth in
their new growths 1234

20 a 10 A—9 lb. 6 oz. 24-POINT ORNAMENTED, No. 1528. \$8.45.

A LARGE BRICK HOTEL
At the bridge was closed 12

15 a 8 A—16 lb. 12 oz. 36-POINT ORNAMENTED, No. 1528. \$13.75.

TRAVELLERS'
Baggage in piles 12

5 a 5 A—14 lb. 12 oz. 48-POINT ORNAMENTED, No. 1528. \$10.60.

TRAIN shed 12

V. B. MUNSON, SUCCESSOR TO
GEO. BRUCE'S SON & CO., 13 CHAMBERS STREET, NEW YORK.

STYLE 1529.

25 a 12 A—4 lb. 8 oz.

18-POINT ORNAMENTED, No. 1529.

\$4.50.

HE WAS RATHER TALL AND STRAIGHT
Under his wide sombrero the upper forehead was
white and smooth as a girl's 1234

20 a 10 A—6 lb. 14 oz.

24-POINT ORNAMENTED, No. 1529.

\$6.20.

GOSPEL SHARKS WE KNOW
And camp cooks and peddlers who get
our wages for tin watches 12

15 a 8 A—12 lb. 8 oz.

36-POINT ORNAMENTED, No. 1529.

\$10.25.

FRINGED TROUSERS
And a soiled linen shirt and
yellow collar 12

5 a 5 A—11 lb. 12 oz.

48-POINT ORNAMENTED, No. 1529.

\$8.45.

EXPRESSIONS
Of friendly regard 4

V. B. MUNSON, SUCCESSOR TO
GEO. BRUCE'S SON & CO., 13 CHAMBERS STREET, NEW YORK.

STYLE 1530.

10 a 10 A—7 lb.

24-POINT ORNAMENTED, No. 1530.

\$6.30.

ORNAMENTATIONS
Unequaled in Conception or
Artistic Detail
Architectural Triumph 12

8 a 8 A—11 lb. 8 oz.

36-POINT ORNAMENTED, No. 1530.

\$9.45.

MARVELLOUS
Results Obtained for
Posterity 12

5 a 5 A—15 lb. 12 oz.

48-POINT ORNAMENTED, No. 1530.

\$11.35.

CAMPAIGN
Literature and
Budge 12

V. B. MUNSON, SUCCESSOR TO
GEO. BRUCE'S SON & CO., 13 CHAMBERS STREET, NEW YORK.

STYLE 1531.

25 a 12 A—4 lb. 14 oz.

18-POINT ORNAMENTED, No. 1531.

\$4.90.

OUTSIDE IT WAS WHITE AND STILL
Almost like a clear, quiet night in the snows of
midwinter; for a heavy white 1234

20 a 10 A—7 lb. 8 oz.

24-POINT ORNAMENTED, No. 1531.

\$6.75.

FROST WAS EVERYWHERE
And in the thin, unmoving air you
almost hear the 1234

15 a 8 A—14 lb.

36-POINT ORNAMENTED, No. 1531.

\$11.50.

LOUD GARMENTS
Of the would-be sports as
they hustle past 12

12 a 7 A—23 lb. 8 oz.

48-POINT ORNAMENTED, No. 1531.

\$16.90.

ON THE WAY
To the Olympic 2

V. B. MUNSON, SUCCESSOR TO
GEO. BRUCE'S SON & CO., 13 CHAMBERS STREET, NEW YORK.

STYLE 1532.

25 a 12 A—5 lb. 10 oz.

18-POINT ORNAMENTED, No. 1532.

\$5.60

ONLY THE TUNEFUL FLOW
And splash of the run, which caught the
living sunlight and 1234

20 a 10 A—9 lb.

24-POINT ORNAMENTED, No. 1532.

\$8.10.

SO FLASHED IT BACK
In radiance through the clear
air, that quivered 123

15 a 8 A—15 lb. 12 oz.

36-POINT ORNAMENTED, No. 1532.

\$12.90.

IN THE ECSTASY
Of free, buoyant life 2

12 a 7 A—25 lb.

48-POINT ORNAMENTED, No. 1532.

\$18.00.

ON SABBATH
Day we rested 2

V. B. MUNSON, SUCCESSOR TO
GEO. BRUCE'S SON & CO., 13 CHAMBERS STREET, NEW YORK.

STYLE 1533.

15 a 15 A—4 lb. 4 oz.

18-POINT ORNAMENTED, No. 1533.

\$4.25.

IN A CONFLICT-WORKED COAL MINE
Two prisoners labored side by side, a negro and
a white man -- labored in chains 1234

10 a 10 A—5 lb. 10 oz.

24-POINT ORNAMENTED, No. 1533.

\$5.05.

THE GUARD'S PRESENCE
Prevented any lengthy interchange
of weighty opinions 123

8 a 8 A—11 lb.

36-POINT ORNAMENTED, No. 1533.

\$9.00.

DISALLOW ANY AGENS
Of conflicts with law 123

5 a 5 A—12 lb. 8 oz.

48-POINT ORNAMENTED, No. 1533.

\$9.00.

AS YOU SOW
So You Mow-See 2

V. B. MUNSON, SUCCESSOR TO
GEO. BRUCE'S SON & CO., 13 CHAMBERS STREET, NEW YORK.

STYLES 1534 AND 1535.

60 & 30 A—1 lb. 10 oz.

6-POINT ORNAMENTED, No. 1534.

\$3.25.

ALL TYPE SHOULD BE SELECTED BY THE MANAGER OR PROPRIETOR. THE FORM OF WORK OF AN OFFICE IS INHERENTLY FIXED BY THE SUPERVISION OF ITS
OWNER. AND THE OWNER HAS AN EXCELLENT OPPORTUNITY TO SHOW HIS GOOD TASTE BY
SELECTING THIS LETTER AS BEING ESPECIALLY APPROPRIATE FOR DANCE, MUSICAL AND CONCERT PROGRAMMES.

<p>OVERTURE--KASUTSER SONATA .</p> <p>ADDRESS--THE SILVER QUESTION .</p> <p>SONG--ANNIE ROBERT</p> <p>VIOLIN SOLO</p> <p>COMIC SONG</p> <p>DICHTATION</p> <p>FLUTE SWINGING</p> <p>BARITONE SOLO</p> <p>SONG--GOOD NIGHT</p>	<p>1. GRAND MARCH.....</p> <p>2. QUADRILLE.....</p> <p>3. WALTZ.....</p> <p>4. SCHOTTISCH.....</p> <p>5. POLKA.....</p> <p>6. VIRGINIA REEL.....</p> <p>7. WALTZ.....</p> <p>8. VEGETABLE QUICKSTEP.....</p> <p>9. QUADRILLE.....</p> <p>10. POLKA.....</p> <p>11. WALTZ.....</p> <p>12. SIR ROGER DE COVERLEY.....</p>	<p>. DANCER</p> <p>. MR. ESCER</p> <p>. MISS COUGHLIN</p> <p>. MR. LINDRAY</p> <p>. MR. SCOR</p> <p>. MISS McMANUS</p> <p>. MASTER CLIFFORD</p> <p>. MR. McGUIRE</p> <p>. MISS FOYLE</p>
--	---	--

ONCE UPON A MIDNIGHT DREAMY, AS I FORGOTTEN WEAR AND WEARY
OVER ALL THE CHRISTMAS PRESENTS THAT A BOVISH FANCY DRAWS;
WHILE WITH SLEEP I TRIED TO TUGGLE, TRIED WITH ALL MY MIGHT AND MUSCLE,
SUDDENLY I HEARD A RUSTLE LIKE THE NOISE OF SANTA CLAUS.

25 & 12 A—5 lb. 6 oz.

20-POINT ORNAMENTED, No. 1535.

\$5.05.

A MOST REALISTIC SCENE
WAS NOW PRESENTED TO THE WONDERING GAZE OF THE
ASSEMBLED MULTITUDE
AS BATTALION AFTER BATTALION, HEADED BY THEIR
BANDS, MARCHED IN AT THE WIDE GATES 1234

V. B. MUNSON, SUCCESSOR TO
GEO. BRUCE'S SON & CO., 13 CHAMBERS STREET, NEW YORK

STYLE 1536.

40 a 20 A—3 lb. 4 oz. 10-POINT ORNAMENTED, No. 1536. \$4.20.

A CLOSE OBSERVER MIGHT HAVE DETECTED
A SLIGHT TREMOR IN THE WELL-GLOVED HANDS THAT HANDLED THE
REINS SO PROFESSIONALLY 1234567890

30 a 15 A—3 lb. 12 oz. 12-POINT ORNAMENTED, No. 1536. \$4.35.

IT WAS EVIDENT THAT THE TRAVELLERS
WERE NOT OF THE COUNTRY, AND OBVIOUS THAT REGARD
FOR THEIR HEALTH BROUGHT THEM HERE 123

25 a 12 A—5 lb. 6 oz. 18-POINT ORNAMENTED, No. 1536. \$5.35.

THE APPEARANCE OF THE LADY
SUGGESTED THAT SHE WOULD BE MORE AT HOME
ON THE BOX OF A FOUR-IN-HAND 123

20 a 10 A—7 lb. 24-POINT ORNAMENTED, No. 1536. \$6.30.

SHE WORE A BIG BUNCH
OF BLUE CARNATIONS, OR SOME SUCH ODD
DECORATION, IN HER BELT 1236

15 a 8 A—12 lb. 6 oz 36-POINT ORNAMENTED, No. 1536. \$10.15.

IN THE MORNING
THE TRAVELLERS STARTED 31

V. B. MUNSON, SUCCESSOR TO
GEO. BRUCE'S SON & CO., 13 CHAMBERS STREET, NEW YORK.

STYLE 1538.

60 a 30 A—2 lb. 8 oz. 8-POINT ORNAMENTED, No. 1538. \$4.00.

I SAID TO MY LUNCH: OH, LUNCH, LATE LUNCH, WILL YOU LIE ON MY
Stomach to-night; will you nestle there, or rear and tear in a huge nightmarish fright? Will you
thrill me with aching pain; will your fits and jerks 1234567890

40 a 20 A—2 lb. 10 oz. 10-POINT ORNAMENTED, No. 1538. \$3.40.

BUST MY STOMACH WORKS SO I NEVER CAN LUNCH AGAIN?
Will you throb like a stone-bruised toe; will you double me up like a poisoned pup,
and fill me with grief and woe? 1234567890

30 a 15 A—2 lb. 12 oz. 12-POINT ORNAMENTED, No. 1538. \$3.20.

AND MY LATE LUNCH GAVE A DYSPEPTIC HUMP,
And answered me fair and true: I'm on to my job, and I'll jump and throb
till the air with your cussing is blue 1234567890

25 a 12 A—4 lb. 12 oz. 18-POINT ORNAMENTED, No. 1538. \$4.75.

THE NEW ARRIVALS ACCOMPANIED
Their visitors to the veranda as they started to their
cabin on the island for the night 1234

20 a 10 A—6 lb. 12 oz. 24-POINT ORNAMENTED, No. 1538. \$6.05.

MADE FAREWELL SPEECHES
That moved the assemblage to tears 123

15 a 8 A—11 lb. 14 oz. 36-POINT ORNAMENTED, No. 1538. \$9.75.

ATTACHED the silverware 12

V. B. MUNSON, SUCCESSOR TO
GEO. BRUCE'S SON & CO., 13 CHAMBERS STREET, NEW YORK.

STYLE 1540.

15 a 15 A—2 lb. 12 oz. 12-POINT ORNAMENTED, No. 1540. \$3.20.

HE COULD SEE HER WHITE DECKS
And the rails of polished brass, and the comfortable
canopied wicker chairs 123456

12 a 12 A—4 lb. 4 oz. 18-POINT ORNAMENTED, No. 1540. \$4.25.

GAILY COLORED CUSHIONS
And flat coils of rope, and the tapering
masts and white yards 123

10 a 10 A—7 lb. 24-POINT ORNAMENTED, No. 1540. \$6.30.

AS HIS LANGUAGE
Is somewhat free we will not
interrupt him 123

8 a 8 A—13 lb. 36-POINT ORNAMENTED, No. 1540. \$10.65.

VENERATION
Reflecting opinions 2

5 a 5 A—16 lb. 4 oz. 48-POINT ORNAMENTED, No. 1540. \$11.70.

GLEN island 4

V. B. MUNSON, SUCCESSOR TO
GEO. BRUCE'S SON & CO., 13 CHAMBERS STREET, NEW YORK.

STYLE 1541.

30 a 15 A—4 lb. 2 oz. 12-POINT ORNAMENTED, No. 1541. \$4.80.

THEY WOULD HAVE BEEN CONSPICUOUS
Anywhere, aside from their unusual dimensions,
both of height and girth 1234567890

25 a 12 A—5 lb. 8 oz. 18-POINT ORNAMENTED, No. 1541. \$5.50.

SHE WORE HER PARIS GOWN
And he was very swell in his pajamas 12

25 a 12 A—8 lb. 8 oz. 22-POINT ORNAMENTED, No. 1541. \$7.65.

UNSTINTED APPLAUSE
Greeted their every appearance 12

20 a 10 A—10 lb. 14 oz. 28-POINT ORNAMENTED, No. 1541. \$9.35.

SMOTHERING SEAS
Washed the reeling deck 12

15 a 8 A—17 lb. 2 oz. 36-POINT ORNAMENTED, No. 1541. \$14.05.

ABAF the shaft 12

5 a 5 A—14 lb. 12 oz. 48-POINT ORNAMENTED, No. 1541. \$10.60.

LONG tennis 12

V. B. MUNSON, SUCCESSOR TO
GEO. BRUCE'S SON & CO., 13 CHAMBERS STREET, NEW YORK.

STYLE 1542.

15 a 15 A—3 lb. 2 oz.

12-POINT ORNAMENTED, No. 1542.

\$3.60.

**'TIS NOT IN MORTALS TO COMMAND
Success, but we'll do more, Sempronius: we'll
deserve it Cheers in the gallery 12**

12 a 12 A—5 lb. 2 oz.

18-POINT ORNAMENTED, No. 1542.

\$5.10.

**LARGE LEATHER MEDALS
For unflinching devotion to duty
Tackling the salt horse 12**

10 a 10 A—8 lb. 6 oz.

24-POINT ORNAMENTED, No. 1542.

\$7.55.

**ARMY AND NAVY
Broad sides of grape 12**

8 a 8 A—16 lb. 5 oz.

36-POINT ORNAMENTED, No. 1542.

\$13.35.

**KEARSARGE
Latest addition 2**

5 a 5 A—19 lb.

48-POINT ORNAMENTED, No. 1542.

\$13.70.

DRY dock 3

V. B. MUNSON, SUCCESSOR TO
GEO. BRUCE'S SON & CO., 13 CHAMBERS STREET, NEW YORK.

STYLE 1543.

30 a 15 A—2 lb. 12 oz.

12-POINT ORNAMENTED, No. 1543.

\$3.20.

THE YOUNG MAN STRUCK A DEFIANT ATTITUDE

And his manner justified our jumping at the conclusion that it was he
who had similarly treated William Patterson 1234

25 a 12 A—4 lb. 4 oz.

18-POINT ORNAMENTED, No. 1543.

\$4.25.

HEROIC DEEDS DESERVING REWARD

Life-savers who daily brave the tempestuous seas to
rescue ship-wrecked mariners 1234

20 a 10 A—7 lb. 2 oz.

24-POINT ORNAMENTED, No. 1543.

\$6.40.

ON THE ROLLING DEEP

Where the scattered waters rave and
winds their revels keep 12

15 a 8 A—12 lb. 5 oz.

36-POINT ORNAMENTED, No. 1543.

\$10.10.

NOTWITHSTANDING

Harbor police regulations 3

5 a 5 A—11 lb. 8 oz.

48-POINT ORNAMENTED, No. 1543.

\$8.30.

STATEN Islander 3

V. B. MUNSON, SUCCESSOR TO
GEO. BRUCE'S SON & CO., 13 CHAMBERS STREET, NEW YORK.

STYLE 1545.

30 a 15 A—3 lb.

12-POINT ORNAMENTED, No. 1545.

\$3.50.

IN ANOTHER MOMENT YOU ARE IN LONDON
Riding through the never-ending restlessness of its streets in a
cab, with your hat-box safe beside you 123

25 a 12 A—4 lb. 14 oz.

18-POINT ORNAMENTED, No. 1545.

\$4.90.

YOUR TRUNK BY THE DRIVER
And old London with its history on all sides of
you, its polished sidewalks 123

20 a 10 A—7 lb. 12 oz.

24-POINT ORNAMENTED, No. 1545.

\$6.95.

BIG BURLY POLICEMEN
And small sweeps at every corner,
providing safe crossing 123

15 a 8 A—14 lb. 4 oz.

36-POINT ORNAMENTED, No. 1545.

\$11.70.

AND PUSH-CARTS
Galorum ad infinitum 2

5 a 5 A—13 lb. 4 oz.

48-POINT ORNAMENTED, No. 1545.

\$9.55.

SHORT Dinner 3

V. B. MUNSON, SUCCESSOR TO
GEO. BRUCE'S SON & CO., 13 CHAMBERS STREET, NEW YORK.

STYLE 1546.

30 a 15 A—3 lb.

12-POINT ORNAMENTED, No. 1546.

\$3.50.

AN AMERICAN ENJOYS LONDON MORE

*During his second visit. He is likely to be a little older, with very
little left of his former prejudice 1234*

25 a 12 A—5 lb.

18-POINT ORNAMENTED, No. 1546.

\$5.00.

THE PORTER AT YOUR HOTEL

*May remember you, and there may be one or two
of the old waiters still left 123*

20 a 10 A—7 lb. 10 oz.

24-POINT ORNAMENTED, No. 1546.

\$6.85.

NELSON'S MONUMENT

*And the National Gallery are both
former friends 1234*

15 a 8 A—13 lb. 10 oz.

36-POINT ORNAMENTED, No. 1546.

\$11.15.

WESTMINSTER

Abbey to old St. Paul's 12

5 a 5 A—13 lb.

48-POINT ORNAMENTED, No. 1546.

\$9.35.

ROYAL yachts 4

V. B. MUNSON, SUCCESSOR TO
GEO. BRUCE'S SON & CO., 13 CHAMBERS STREET, NEW YORK.

STYLE 1547.

30 a 15 A—3 lb. 8 oz.

12-POINT ORNAMENTED, No. 1547.

\$4.05.

COUNTRY BOYS LOOKING WITH ENVY

*At the smart uniforms of the soldiers, and with terror at
the dingy army of sandwich men 1234*

25 a 12 A—5 lb. 10 oz.

18-POINT ORNAMENTED, No. 1547.

\$5.60.

SHUFFLING THROUGH THE

*Gutter carrying advertisements of hot and
cold luncheons, baths 1245*

10 a 10 A—6 lb. 12 oz.

24-POINT ORNAMENTED, No. 1547.

\$6.05.

MANICURE PARLORS

*Serving as terrible examples of
the fate of those who 12*

8 a 8 A—11 lb. 12 oz.

36-POINT ORNAMENTED, No. 1547.

\$9.65.

FAIL TO ENLIST

And become soldiers 12

5 a 5 A—13 lb. 12 oz.

48-POINT ORNAMENTED, No. 1547.

\$9.90.

GRAVE *crises 4*

V. B. MUNSON, SUCCESSOR TO
GEO. BRUCE'S SON & CO., 13 CHAMBERS STREET, NEW YORK.

STYLE 1548.

12 a 12 A—4 lb. 2 oz.

18-POINT ORNAMENTED, No. 1548.

\$4.10.

THE DIRTY OLD RAT MAN

And his pets find Brighton too dull in the winter
and come up to London 123

10 a 10 A—6 lb. 6 oz.

24-POINT ORNAMENTED, No. 1548.

\$5.75.

THERE IS NO NEED

To go faster than a horse can trot
and the best way 123

8 a 8 A—10 lb. 8 oz.

36-POINT ORNAMENTED, No. 1548.

\$8.60.

IS TO WALK IT

If you are too tired to run
and can't fly 12

5 a 5 A—12 lb. 2 oz.

48-POINT ORNAMENTED, No. 1548.

\$8.75.

CONSTANT

Roars and yells 3

V. B. MUNSON, SUCCESSOR TO
GEO. BRUCE'S SON & CO., 13 CHAMBERS STREET, NEW YORK.

STYLE 1552.

25 a 12 A—7 lb. 2 oz.

18-POINT ORNAMENTED, No. 1552.

\$7.10.

GIVE ME A GOOD DINNER
After it a good cigar, then I will
serve you such a nice 12

20 a 10 A—11 lb. 8 oz.

24-POINT ORNAMENTED, No. 1552.

\$10.35.

BRIGHT, SUNSHINY
Sheet of reverie, twisted
out of the smoke 12

15 a 8 A—18 lb. 2 oz.

36-POINT ORNAMENTED, No. 1552.

\$14.85.

'T WILL MAKE
Your old heart 23

5 a 5 A—18 lb. 8 oz.

48-POINT ORNAMENTED, No. 1552.

\$13.30.

TO A CHE
Aunty dear 2

V. B. MUNSON, SUCCESSOR TO
GEO. BRUCE'S SON & CO., 13 CHAMBERS STREET, NEW YORK.

STYLE 1553.

25 a 12 A—5 lb. 6 oz.

18-POINT ORNAMENTED, No. 1553.

\$5.35.

TALL ELMS RISE HERE AND THERE

**Along the margin of the valley, their leafy
arms recklessly throwing 123**

20 a 10 A—7 lb. 10 oz.

24-POINT ORNAMENTED, No. 1553.

\$6.85.

GREAT PATCHES OF SHADE

**Upon the meadow, where the quiet
cud-chewing herd 123**

15 a 8 A—12 lb. 6 oz.

36-POINT ORNAMENTED, No. 1553.

\$10.15.

WOULD BE VISIBLE

Had it not been sold for 12

12 a 5 A—10 lb. 12 oz.

48-POINT ORNAMENTED, No. 1553.

\$7.75.

A THOUSAND

Pounds last week 2

V. B. MUNSON, SUCCESSOR TO
GEO. BRUCE'S SON & CO., 13 CHAMBERS STREET, NEW YORK.

STYLE 1557.

30 a 15 A—2 lb. 6 oz.

12-POINT ORNAMENTED, No. 1557.

\$2.75.

THE VILLAGE WAS EMPTY, EXCEPT FOR THE FAMILIES OF
Native workmen and the ownerless dogs, the scavengers of the colony, that snarled
and barked and ran leaping in front of the ponies' heads 1234

25 a 12 A—3 lb. 8 oz.

18-POINT ORNAMENTED, No. 1557.

\$3.50.

RISING ABRUPTLY ABOVE THE ZING VILLAGE
Lay the first of the five great hills, with its open front cut into
great terraces, on which the men clung 1234

20 a 10 A—5 lb. 6 oz.

24-POINT ORNAMENTED, No. 1557.

\$4.85.

LIKE FLIES ON THE SIDE OF A WALL,
Some of them in groups around an opening, or in
couples pounding a steel bar held 1234

15 a 8 A—8 lb. 6 oz.

36-POINT ORNAMENTED, No. 1557.

\$6.85.

BY A FELLOW WORKMAN,
While others stood idly by, simply 12

5 a 5 A—9 lb.

48-POINT ORNAMENTED, No. 1557.

\$6.50.

WAITING for 6 o'clock 12

STYLE 1558.

30 a 15 A—2 lb. 10 oz. 12-POINT ORNAMENTED, No. 1558. \$3.05.

SELF-IMPORTANT LITTLE DUMMY ENGINES, DRAGGING LONG
Trains of ore cars, rolled and rocked on the uneven surface of the road,
and swung around the sharp corners and curves 1234

25 a 12 A—4 lb. 4 oz. 18-POINT ORNAMENTED, No. 1558. \$4.25.

WITH WARNING SHRIEKS OF THEIR WHISTLES.
We could see, on the peaks outlined against the sky, the
signal-men waving their red flags, and 123

20 a 10 A—6 lb. 10 oz. 24-POINT ORNAMENTED, No. 1558. \$5.95.

PLUNGING DOWN THE MOUNTAIN
Out of danger, as the earth rumbled and
shook and vomited out a 123

15 a 8 A—10 lb. 14 oz. 36-POINT ORNAMENTED, No. 1558. \$8.90.

SHOWER OF STONES
And rubbish into the air 123

5 a 5 A—9 lb. 6 oz. 48-POINT ORNAMENTED, No. 1558. \$6.75.

VIGOROUS activity 12

V. B. MUNSON, SUCCESSOR TO
GEO. BRUCE'S SON & CO., 13 CHAMBERS STREET, NEW YORK.

STYLE 1559.

60 a 30 A—3 lb. 4 oz.

8-POINT ORNAMENTED, No. 1559.

\$5.20.

THE SHUTTERS WERE BEATING VICIOUSLY AGAINST THE
Side of the house, the wind rushing through the palms, the rain beating in splashes
on the zinc roof. It did not come soothingly, but like the 12345

40 a 20 A—3 lb. 6 oz.

10-POINT ORNAMENTED, No. 1559.

\$4.40.

RUSH OF WAVES SWEEPING OVER A ROUGH
Beach. The storm slackened somewhat but did not cease, and the
rain fell with dreary, relentless persistence. 123

30 a 15 A—3 lb. 14 oz.

12-POINT ORNAMENTED, No. 1559.

\$4.55.

RIVULETS OF MUDDY WATER HAD
Cut gutters over the lawn, and poured from under
the veranda, and plants and palms 123

25 a 12 A—6 lb. 12 oz.

18-POINT ORNAMENTED, No. 1559.

\$6.75.

LAY BENT AND BROKEN
We had together planned to wear 12

20 a 10 A—10 lb. 4 oz.

24-POINT ORNAMENTED, No. 1559.

\$9.20.

BLUE JEAN SUITS
And a smile, but the smile 3

15 a 8 A—16 lb.

36-POINT ORNAMENTED, No. 1559.

\$13.10.

HAD BECOME
A chronic grin 234

V. B. MUNSON, SUCCESSOR TO
GEO. BRUCE'S SON & CO., 13 CHAMBERS STREET, NEW YORK.

DE VINNE EXTENDED

72 POINT

3 A 4 a \$21 00

GUM
Bands

60 POINT

3 A 4 a \$16 00

FINE
Grinder

54 POINT

3 A 4 a \$13 00

STAR
Beamed

DE VINNE EXTENDED

48 POINT

3 A 4 a \$11 50

HOME
Fashions

42 POINT

4 A 5 a \$10 00

FARMS
Fine Cattle

36 POINT

4 A 6 a \$8 00

SPRING
Sugar Barrel

30 POINT

5 A 8 a \$7 00

INDUSTRY
Missouri Firms

BRUCE TYPE FOUNDRY, 13 CHAMBERS STREET, NEW YORK.

DE VINNE EXTENDED

24 POINT

6 A 10 a \$6 00

EXPOSITION
Home Manufacture

18 POINT

9 A 12 a \$4 50

UNIFORM PRINT
Looks Plain and Artistic

14 POINT

10 A 14 a \$3 75

BEAUTIFUL SCENE
Views From Excursion Boats

12 POINT

14 A 18 a \$3 50

NINETEENTH CENTURY
Base Ball and Lawn Tennis Player

10 POINT

18 A 24 a \$3 00

EUROPEAN BICYCLE EXHIBITION
American Products Receive Highest Awards
Enterprising Competitors

8 POINT

22 A 30 a \$2 75

MODEST YOUTHS
Introduced to Director
Gratifying Result
12345678

6 POINT

24 A 36 a \$2 50

JUVENILE ORCHESTRA
Renders Popular Selections
Thursday Evening
1234567890

DE VINNE SERIES

72 POINT

A 5 a \$17 00

MODISH
Costume

60 POINT

4 A 5 a \$12 25

MERIDEN
Romances

54 POINT

4 A 5 a \$10 25

DESIGNER
Bond Notes

BRUCE TYPE FOUNDRY, 13 CHAMBERS STREET, NEW YORK.

DE VINNE SERIES

48 POINT

4 A 5 a \$7 75

**EXPORTING
Cheap Grade
of Neckwear**

42 POINT

4 A 6 a \$7 25

**BAKED SHAD
Served Daily to
Regular Guests**

36 POINT

5 A 8 a \$5 50

**HEROIC ACTION
Under Heavy Fire
by a Young Cadet**

DE VINNE SERIES

30 POINT

8 A 9 a \$5 00

RIGHTS OF LIBERTY
When in the course of
events it becomes 503

24 POINT

8 A 10 a \$4 00

ALEXANDER HAMILTON
When in the course of time
it became necessary for one
people to dissolve the 9076

18 POINT

10 A 16 a \$3 25

DECLARE OUR INDEPENDENCE
When, in the course of time, it will
be found necessary for one people to
dissolve the bands which have 456

14 POINT

12 A 18 a \$3 25

EQUAL STATION AMONG THE POWERS
When, in the course of human events, it be-
comes necessary for one people to dissolve
the political bands which connect them with
another, and to assume, among the 1236890

Lining Figures only furnished with regular fonts. Old Style Figures furnished in separate fonts

DE VINNE SERIES

12 POINT

16 A 20 a \$3 00

PROCLAIM LIBERTY THROUGHOUT THE LAND

When, in the course of human events, it becomes necessary for one people to dissolve the bands which have connected them with another, and to assume, among the powers, the separate and equal station to which the laws of nature and of nature's God entitle them, a decent respect to the opinions of mankind 809

10 POINT

20 A 26 a \$2 75

THE BASIS FOR THE CONSTITUTION OF THE UNITED STATES

When, in the course of human events, it becomes necessary for one people to dissolve the political bands which have connected them with another, and to assume, among the powers of the earth, the separate and equal station to which the laws of nature and of nature's God entitle them, a decent respect to the opinions of mankind requires that they should declare the causes which impel them to the separation. We hold these truths to be self-evident 978

8 POINT

22 A 30 a \$2 50

REVOLUTIONARY CONVENTIONS

When, in the course of events, it becomes necessary for one people to dissolve the political bands which have connected them with another, and to assume, among the powers of the earth, the separate and equal station to which the laws of nature and of nature's God entitle 315789

7 POINT

22 A 34 a \$2 50

PROCLAIMS SELF-EVIDENT TRUTHS

When, in the course of human events, it becomes necessary for one people to dissolve the political bands which have connected them with another, and to assume, among the powers of the earth, the separate and equal station to which the laws of nature and of nature's God entitle them, a decent respect to the opinions of mankind requires that 86

6 POINT

24 A 36 a \$2 25

RIGHTS OF THE COLONIES RESERVED

When, in the course of human events, it becomes necessary for one people to dissolve the political bands which have connected them with another, and to assume, among the powers of the earth, the separate and equal station to which the laws of nature and of nature's God entitle them, a decent respect to the opinions of mankind requires that they should declare the causes which impel them to the separation. We hold 2560

5½ POINT

24 A 36 a \$2 50

GIVING FREEDOM AND INDEPENDENCE

When, in the course of human events, it becomes necessary for one people to dissolve the political bands which have connected them with another, and to assume, among the powers of the earth, the separate and equal station to which the laws of nature and of nature's God entitle them, a decent respect to the opinions of mankind requires that they should declare the causes which impel them to the separation. We hold these truths to be self-evident, that all men 2345

Lining Figures only furnished with regular fonts. Old Style Figures furnished in separate fonts

DE VINNE CONDENSED

72 POINT

4 A 5 a \$15 00

DESIGNER
Requesting

60 POINT

4 A 5 a \$10 00

HORSEMEN
Scare Riders

54 POINT

4 A 5 a \$7 50

BURNISHERS
Found Advice

DE VINNE CONDENSED

48 POINT

4 A 5 a \$8 00

HOME COMING
Member Desires
Song of Evening

42 POINT

4 A 6 a \$5 50

WOMEN SEARCH
Engage Children to
Recite Good Poems

36 POINT

5 A 8 a \$5 00

STUDENTS REBUILD
Exercising to Develop
the Muscles of Wrists

DE VINNE CONDENSED

30 POINT

8 A 9 a 84 50

FREEDOM AND LIBERTY
When, in the course of time
it seems necessary for one
people of equal station 1475

24 POINT

8 A 12 a 84 00

SUFFERINGS OF THE COLONIES
When, in the course of human life,
it becomes necessary for one people
to dissolve the political band which
connected them with another 1392

18 POINT

10 A 16 a 83 25

OUR PROTEST AGAINST UNJUST TAXES
When, in the pursuit of human events, it
becomes necessary for one people to break
the political bands which have joined them
with one another, and to assume, among the
powers of the earth, the separate and 7986

DE VINNE CONDENSED

14 POINT

12 A 20 a \$3 25

LONG FOLLOWING OF ABUSES AND USURPATION
When, in the course of human incidents, it becomes necessary for one people to break the political bands which have connected them with one another, and to assume, among the powers of the earth, the separate and equal station to which the laws of nature 1947

12 POINT

18 A 22 a \$3 00

ALTERING FUNDAMENTALLY THE FORMS OF GOVERNMENT
When, in the course of human events, it becomes necessary for one people to dissolve the political bands which have connected them with one another, and to assume, among the powers of the earth, the separate and equal station to which the laws of nature and of nature's God entitle them, a decent respect to the opinions of mankind requires that they should declare the causes 5973

10 POINT

22 A 30 a \$2 75

TAKING AWAY OUR CHARTERS, ABOLISHING OUR MOST VALUABLE LAWS
When, in the course of human events, it becomes necessary for one people to dissolve the political bands which have connected them with one another, and to assume, among the powers of the earth, the separate and equal station to which the laws of nature and of nature's God sanction them, a decent respect to the opinions of mankind requires that they should declare the causes which impel them to the separation. We hold these truths to be self-evident, that all men are created equal; that they are endowed by their Creator with certain 1234567890

8 POINT

25 A 36 a \$2 50

SECURES CONSENT OF THE GOVERNED
When, in the course of human events, it becomes necessary for one people to dissolve the bands which connect them with another, and to assume, among the powers of the earth, the separate and equal station to which the laws of nature and of nature's God entitle them, a decent respect to the opinions of mankind requires that 71958

6 POINT

30 A 42 a \$2 25

LIFE, LIBERTY, AND THE PURSUIT OF HAPPINESS
When, in the course of human events, it becomes necessary for one people to dissolve the political bands which have connected them with another, and to assume among the powers of the earth the separate and equal station to which the laws of nature and of nature's God entitle them, a decent respect to the opinions of mankind requires that they should declare the causes which impel them to the separation. We hold these truths to be self-evident, that all men are created equal; that they are endowed by their Creator

72 POINT

4 A 5 a \$15 00

NOBLE Horses

60 POINT

4 A 5 a \$9 00

Brought ROCKER

54 POINT

5 A 7 a \$8 00

DURABLE Flooring

48 POINT

5 A 8 a \$7 00

Landscape IMPROVED

42 POINT

6 A 10 a \$6 00

**MODERN CUISINE
Clothed in Deep Mystery**

36 POINT

6 A 12 a \$5 50

COLLEGE MONTHS
Bright Maidens in Attendance

30 POINT

8 A 12 a \$5 00

NUMEROUS LANDMARKS
Throughout Cumberland Discovered

24 POINT

10 A 16 a \$4 00

INNUMERABLE REQUISITIONS
Administrations Upholding Monroe Doctrine

18 POINT

12 A 20 a \$3 25

DISPLAY BEAUTIFUL FLORAL DESIGNS
Seventh Annual International Chrysanthemum Exhibit
Handsome Flowers Displayed

14 POINT

18 A 22 a \$3 25

NATIONAL CONVENTION
Mississippi Valley Metropolis
1 2 3 4 5 6 7 8 9 0

12 POINT

20 A 26 a \$3 00

VENEZUELAN COMMISSION
Arbitration Now Becomes Necessary
1 2 3 4 5 6 7 8 9 0

72 POINT

4 A 5 a \$19 00

Lost RIG

60 POINT

4 A 5 a \$13 25

RUN Fast

54 POINT

4 A 5 a \$11 25

Read NICE

48 POINT

4 A 5 a \$7 75

BEAR Skins

42 POINT

4 A 6 a \$7 25

Beaver DIVES

36 POINT

5 A 8 a \$6 50

GRAND Festival

30 POINT

6 A 9 a \$5 75

***BLUSTERING
Destructive Cyclones***

24 POINT

8 A 10 a \$4 50

***FIRING ROCKETS
Distress Signals Answered***

18 POINT

10 A 16 a \$4 00

***WANDERING ARABIANS
Experienced Numerous Hardships***

14 POINT

12 A 18 a \$3 25

***DELIGHTFUL HOLIDAY SEASON
Society Whirlwinds Unceasingly Blowing
Frivolous Dames Dancing***

12 POINT

16 A 20 a \$3 00

***UNDERSTANDS
Thoroughly Mechanical***

10 POINT

20 A 26 a \$2 75

***ARMENIAN MASSACRE
Turkish Cruelty Shows Plainly***

8 POINT

22 A 30 a \$2 50

***CHICAGO WEEKLY NEWS
Universally Pronounced Brilliancy
1234567890***

6 POINT

24 A 36 a \$2 25

***AMERICAN TYPE FOUNDRY
Manufactures Superior Printing Materials
1234567890***

BINNER GOTHIC

72 POINT

5 A 8 a \$9 00

FARMERS Inauguration

60 POINT

7 A 10 a \$8 00

Manufacturers EXPENDITURE

48 POINT

8 A 12 a \$7 00

DISTINGUISHED Artistic Thermometer

36 POINT

10 A 15 a \$6 00

MODERN RAILROAD
Delights Excursionists

30 POINT

12 A 18 a \$5 00

PERMANENT INVESTMENT
Eastern Historical Society

24 POINT

14 A 20 a \$4 00

BURNING ELEVATORS UNNOTICED
Mild Languor of Soft Brown Eyes
1234567890

18 POINT

18 A 27 a \$3 25

ADMIRER BEAUTIFUL FOLDING SLEEVES
Funeral Services Held Over Dead Soldiers
1234567890

STYLE 1561.

30 a 15 A—2 lb. 10 oz.

12-POINT ORNAMENTED, No. 1561.

\$3.05.

EXCEPT FOR THE CEASELESS MURMUR OF INSECT LIFE
About them the night was absolutely still, so still that the striking of the
ships' bells in the harbor came to them sharply 123456

25 a 12 A—4 lb. 6 oz.

18-POINT ORNAMENTED, No. 1561.

\$4.35.

ACROSS THE SURFACE OF THE WATER,
And they could hear from time to time the splash of
some great fish and the 12345678

20 a 10 A—6 lb.

24-POINT ORNAMENTED, No. 1561.

\$5.40.

STEADY CREAKING OF AN OAR
In a rowlock, that grew fainter and fainter
as it drew further away 1234

15 a 8 A—10 lb.

36-POINT ORNAMENTED, No. 1561.

\$8.20.

UNTIL IT WAS DROWNED
In the distance or the murky 1234

12 a 7 A—15 lb.

48-POINT ORNAMENTED, No. 1561.

\$10.80.

WATERS OF THE BAY
Sic semper tyrannus 12345

V. B. MUNSON, SUCCESSOR TO
GEO. BRUCE'S SON & CO., 13 CHAMBERS STREET, NEW YORK.

STYLE 1562.

30 a 15 A—3 lb. 8 oz.

12-POINT ORNAMENTED, No. 1562.

\$4.05.

BUT THE LOGUST TREES, HUNG WITH THE
Grape-like bunches of white blossoms, were all hazy with
the quivering wings of dusk-moths 12343

25 a 12 A—5 lb. 6 oz.

18-POINT ORNAMENTED, No. 1562.

\$5.35.

SLENDER SPHINX-MOTHS DARTED
And turned and hovered over the phlox, gray
wraiths of dead humming-birds 123

20 a 10 A—7 lb. 12 oz.

24-POINT ORNAMENTED, No. 1562.

\$6.95.

POISED OVER PHANTOM
Flowers, the spray drifting like 12

15 a 8 A—13 lb. 10 oz.

36-POINT ORNAMENTED, No. 1562.

\$11.15.

A VEIL OF MIST
Across the shadowy 12

5 a 5 A—11 lb. 8 oz.

48-POINT ORNAMENTED, No. 1562.

\$8.40.

BLOSSOMS
Of white iris 234

V. B. MUNSON, SUCCESSOR TO
GEO. BRUCE'S SON & CO., 13 CHAMBERS STREET, NEW YORK.

STYLE 1563.

30 a 15 A—3 lb. 10 oz. 12-POINT ORNAMENTED, No. 1563. \$4.20.

THE BRANCHES OF THE TREES ON THE EDGES
Of the bare parade ground were black with men and
boys, and the balconies and roofs of 123

25 a 12 A—5 lb. 18-POINT ORNAMENTED, No. 1563. \$5.00.

HOUSES THAT FACED IT WERE GAY
With flags and bunting, and alive with women
wrapped for the occasion in 1234

20 a 10 A—6 lb. 10 oz. 24-POINT ORNAMENTED, No. 1563. \$5.95.

THEIR GAY COLORED SHAWLS
On the grass surging up and down 12

15 a 8 A—10 lb. 2 oz. 36-POINT ORNAMENTED, No. 1563. \$8.30.

BEHIND THEM WERE
More thousands, hurrying 12

5 a 5 A—8 lb. 8 oz. 48-POINT ORNAMENTED, No. 1563. \$6.10.

TO GET A GLIMPSE
Of the great pageant 12

V. B. MUNSON, SUCCESSOR TO
GEO. BRUCE'S SON & CO., 13 CHAMBERS STREET, NEW YORK.

STYLE 1567.

. 15 a 15 A—2 lb. 10 oz. 12-POINT ORNAMENTED, No. 1567. \$3.05.

**THE MOON ROSE GRANDLY A FEW MINUTES
Later, and flooded the forest with light so that 1234**

12 a 12 A—4 lb. 6 oz. 18-POINT ORNAMENTED, No. 1567. \$4.35.

**OPEN PLACES WERE CLEAR AS
Day, strange shadows were thrown 123**

10 a 10 A—5 lb. 12 oz. 24-POINT ORNAMENTED, No. 1567. \$5.15.

**ATHWART THE TRAIL,
Turning rocks and fallen trees 12**

8 a 8 A—7 lb. 12 oz. 30-POINT ORNAMENTED, No. 1567. \$6.50.

**TO HUMAN FORMS
Crouching or standing 12**

6 a 6 A—9 lb. 36-POINT ORNAMENTED, No. 1567. *\$7.40.

CHRYSAnthemum 12

5 a 5 A—11 lb. 10 oz. 48-POINT ORNAMENTED, No. 1567. \$8.35.

COMMissioner 12

V. B. MUNSON, SUCCESSOR TO
GEO. BRUCE'S SON & CO., 13 CHAMBERS STREET, NEW YORK.

STYLE 1568.

15 a 15 A—2 lb. 2 oz. 12-POINT ORNAMENTED, No. 1568. \$2.45.

FROM THE FOREST THEY CAME TO LITTLE STREAMS
And broad shallow rivers, the rocks in the fording places 123

12 a 12 A—3 lb. 6 oz. 18-POINT ORNAMENTED, No. 1568. \$3.35.

CHURNING THE WATER INTO MASSES
Of foam, and the horses kicking up showers 123

10 a 10 A—4 lb. 8 oz. 24-POINT ORNAMENTED, No. 1568. \$4.05.

AND CLOUDS OF SPRAY AS THEY
Made their way against the current 123

8 a 8 A—6 lb. 30-POINT ORNAMENTED, No. 1568. \$5.05.

NOT FOR ONE MOMENT
Was present peril thought of 12

6 a 6 A—7 lb. 36-POINT ORNAMENTED, No. 1568. \$5.75.

LOVE, WAR and politics 12

5 a 5 A—8 lb. 12 oz. 48-POINT ORNAMENTED, No. 1568. \$6.30.

MERCHANT prince 12

V. B. MUNSON, SUCCESSOR TO
GEO. BRUCE'S SON & CO., 13 CHAMBERS STREET, NEW YORK.

STYLE 1570.

15 a 15 A—3 lb.

12-POINT ORNAMENTED, No. 1570.

\$3.50.

**THEY PASSED AT INTERVALS THROUGH
Sleepy villages of mud huts with straw roofs 123**

12 a 12 A—4 lb. 14 oz.

18-POINT ORNAMENTED, No. 1570.

\$4.90.

**DOGS RAN YELPING OUT
To bark furiously at passers-by 123**

10 a 10 A—6 lb. 12 oz.

24-POINT ORNAMENTED, No. 1570.

\$6.05.

**ELECTRIC CABS DASH
By with their peculiar whir 12**

8 a 8 A—8 lb. 12 oz.

30-POINT ORNAMENTED, No. 1570.

\$7.35.

**NIGHT CAME ON
As usual about now 12**

6 a 6 A—10 lb. 2 oz.

36-POINT ORNAMENTED, No. 1570.

\$8.30.

TOUT ensemble 12

5 a 5 A—11 lb. 10 oz.

48-POINT ORNAMENTED, No. 1570.

\$8.35.

MALCOntent 12

V. B. MUNSON, SUCCESSOR TO
GEO. BRUCE'S SON & CO. 13 CHAMBERS STREET, NEW YORK.

STYLE 1571.

15 a 15 A—2 lb. 6 oz. 12-POINT ORNAMENTED, No. 1571. \$2.75.

WE SKIRTED THE EDGE OF A PRECIPICE AND
Looked down tens of thousands of feet below at the 123

12 a 12 A—4 lb. 18-POINT ORNAMENTED, No. 1571. \$4.00.

ROARING, RAGING, WHITE-CRESTED
Torrent that lashed itself into impotent 123

10 a 10 A—5 lb. 2 oz. 24-POINT ORNAMENTED, No. 1571. \$4.60.

FURY AT ITS FAILURE TO
Engulf our party in its dampness 12

8 a 8 A—6 lb. 8 oz. 30-POINT ORNAMENTED, No. 1571. \$5.45.

HA! YOU ARE SILENT
You cannot answer! Nuf 12

6 a 6 A—7 lb. 12 oz. 36-POINT ORNAMENTED, No. 1571. \$6.35.

SHAMROCK leading 12

5 a 5 A—10 lb. 6 oz. 48-POINT ORNAMENTED, No. 1571. \$7.45.

OCTOBER 20, noon!

V. B. MUNSON, SUCCESSOR TO
GEO. BRUCE'S SON & CO., 13 CHAMBERS STREET, NEW YORK.

STYLE 400.

60 a 20 A—2 lb.

6-POINT BLACK, No. 400.

\$4.00.

When the winter winds are wailing with a weird and dismal wail,
And the flimsy flakes are flying on the pinions of the gale;
When the fierce Atlantic billows, with a sullen, angry roar,
Rush up the sandy beach and dash against the rock-bound shore;
When from the polar regions comes the frost king in his might,
When we hear the storm fiends shrieking through the tenebrous night;

60 a 20 A—3 lb. 4 oz.

8-POINT BLACK, No. 400.

\$5.20.

The Nation has more to be thankful for in **ABCDEFGHIJKLMN** than for many a year past: The successful and speedy termination of the War with Spain; Dewey's magnificent victory at Manila, which gave us an Empire across the seas

40 a 14 A—3 lb. 12 oz.

10-POINT BLACK, No. 400.

\$4.85.

And an established place among the Great Powers of the world; peace and prosperity at home, with plenty of work for all and at good wages. Surely we all have much to be thankful for

30 a 10 A—4 lb. 2 oz.

12-POINT BLACK, No. 400.

\$4.80.

Under their learned counsel the House of the Golden Pillars took on a new magnificence. Artists were brought from Corinth and Rome and Hoboken

25 a 8 A—8 lb. 2 oz.

18-POINT BLACK, No. 400.

\$8.10.

Lavish banquets of the most scandalous cost enticed all the highest-toned guests into its dining halls

STYLES 400 AND 500.

25 a 8 A—13 lb. 6 oz.

22-POINT BLACK, No. 400.

\$12.05.

**Everything he touched
was Blighted**

15 a 6 A—20 lb. 12 oz.

36-POINT BLACK, No. 400.

\$17.00.

**As Fair as the
Girl of Troy**

25 a 8 A—8 lb. 8 oz.

18-POINT BLACK OPEN, No. 500.

\$8.50.

**Backward, roll backward, O
Time, in your flight**

25 a 8 A—13 lb. 12 oz.

22-POINT BLACK OPEN, No. 500.

\$12.35.

**Make Me a child again
Just for to-night**

15 a 6 A—20 lb. 12 oz.

36-POINT BLACK OPEN, No. 500.

\$17.00.

**Like a river is
strong and**

V. B. MUNSON, SUCCESSOR TO
GEO. BRUCE'S SON & CO., 13 CHAMBERS STREET, NEW YORK.

STYLE 401.

60 a 20 A—3 lb.

8-POINT BLACK, No. 401.

\$4.80.

Next morning the strange old man whom we had seen in the Grobe of Daphne, but neber since, appeared mysteriously at the door of the house, as if he had been sent for, and entered, to dwell there like an invited guest

40 a 14 A—3 lb. 8 oz.

10-POINT BLACK, No. 401.

\$4.55.

Hermas could not but make him Welcome, and at first he tried hard to regard him with Reverence and Affection, as the one person through whom his good fortune had come

30 a 10 A—3 lb. 8 oz.

12-POINT BLACK, No. 401.

\$4.05.

There was a chill in the inscrutable smile of Ontis, as he called himself, that seemed to mock at reverence. He was in the house as one watching a Strange Experiment

30 a 10 A—4 lb.

14-POINT BLACK, No. 401.

\$4.50.

In his presence Hermas was conscious of a certain irritation, a Resentful Anger against the calm, frigid scrutiny 123

25 a 8 A—5 lb. 8 oz.

18-POINT BLACK, No. 401.

\$5.50.

Tranquil, interested and ready to supply anything that might be needed for its completion 123

25 a 8 A—8 lb. 12 oz.

22-POINT BLACK, No. 401.

\$7.85.

Curiously watching to see how long it would continue, yet oblivious 125

WE ALSO MAKE 72-POINT OF THIS SERIES.

V. B. MUNSON, SUCCESSOR TO
GEO. BRUCE'S SON & CO., 13 CHAMBERS STREET, NEW YORK.

STYLES 401, 501, 502 AND 510.

5 a 3 A—20 lb.

72-POINT BLACK, No. 401.

\$12.80.

The Nation

5 a 3 A—19 lb. 4 oz.

72-POINT BLACK OPEN, No. 501.

\$12.25.

New Epoch

5 a 3 A—19 lb. 4 oz.

72-POINT BLACK OPEN, No. 502.

\$12.25.

Republican

5 a 3 A—27 lb. 14 oz.

84-POINT MODERN TEXT, No. 510.

\$16.70.

City Times

V. B. MUNSON, SUCCESSOR TO
GEO. BRUCE'S SON & CO., 13 CHAMBERS STREET, NEW YORK.

STYLE 504.

60 a 20 A—2 lb. 12 oz. 8-POINT AUGUSTAN BLACK, No. 504. \$4.40.

Eyes that followed him everywhere, a Pair of Spies, peering out over the Smiling Mouth and long white Beard. A perpetual Haste took possession of him, an Uneasiness that left him no Repose. The Summit of Life had been attained after incessant effort 1234567890

40 a 14 A—2 lb. 14 oz. 10-POINT AUGUSTAN BLACK, No. 504. \$3.75.

The highest possible point of Felicity. Henceforward the course could only be at a level, perhaps Downward. It might be Brief; at best it could not be very Long. It was folly to lose a day, an hour 123456

30 a 10 A—3 lb. 10 oz. 12-POINT AUGUSTAN BLACK, No. 504. \$4.20.

That would be the only Fatal Mistake: to forfeit anything of the Bargain that he had made. He would have it, and Hold it, and Enjoy it to the full 1234567890

25 a 8 A—5 lb. 6 oz. 18-POINT AUGUSTAN BLACK, No. 504. \$5.35.

The World probably had Nothing Better to give than it had already given; but surely it had Many Things that were New 1234

20 a 7 A—7 lb. 12 oz. 24-POINT AUGUSTAN BLACK, No. 504. \$6.95.

The beauty of Athenais lost nothing with the Passing Seasons, but grew the more Perfect even

V. B. MUNSON, SUCCESSOR TO
GEO. BRUCE'S SON & CO., 13 CHAMBERS STREET, NEW YORK.

STYLE 505.

40 a 14 A—2 lb. 6 oz.

10-POINT CHURCH TEXT, No. 505.

\$3.10.

Another drop of success fell into his brimming cup. His black Numidian Horses, which he had been training for three years for the world-renowned Races of Antioch won the victory over a score of rivals. Hermas received the Prize carelessly 1234567890

30 a 10 A—3 lb. 4 oz.

14-POINT CHURCH TEXT, No. 505.

\$3.65.

And turned to drive once more around the Circus to show himself to the People. He lifted the eager Boy into the Chariot beside him to share his triumph. Here, indeed, was the glory

25 a 8 A—4 lb. 6 oz.

18-POINT CHURCH TEXT, No. 505.

\$4.35.

Of his life, this Matchless Son, his brighter counterpart, carved in breathing Ivory, touching his arm and Balancing Himself proudly on the swaying floor of the Chariot 1234

25 a 8 A—5 lb. 10 oz.

22-POINT CHURCH TEXT, No. 505.

\$5.05.

As the horses pranced around the Ring a thundering shout of applause filled the Amphitheatre, and Thousands of Spectators waved their salutations

20 a 7 A—7 lb. 10 oz.

28-POINT CHURCH TEXT, No. 505.

\$6.55.

Hail, clever Hermas, master of success! Hail, little Hermas, Prince of Good Luck!

V. B. MUNSON, SUCCESSOR TO
GEO. BRUCE'S SON & CO., 13 CHAMBERS STREET, NEW YORK.

STYLE 506.

30 a 10 A—3 lb. 6 oz. 14-POINT CONDENSED BLACK, No. 506. \$3.80.

Hermas was entertaining his Father's nearest friend, the sophist Libanius,
with his daughter the beautiful Athenais, in the triclinium

25 a 8 A—4 lb. 2 oz. 18-POINT CONDENSED BLACK, No. 506. \$4.10.

When the visit of the Presbyter was announced, the young man
loosed a collar of Gold and Jewels from his neck

20 a 7 A—7 lb. 4 oz. 28-POINT CONDENSED BLACK, No. 506. \$6.25.

Take this to John of Antioch, and tell him it
is a Gift from his former Pupil

15 a 6 A—9 lb. 8 oz. 36-POINT CONDENSED BLACK, No. 506. \$7.80.

I will always send Him what he
wants, but it is Useless for us

12 a 5 A—16 lb. 4 oz. 48-POINT CONDENSED BLACK, No. 506. \$11.70.

The exile of Hermas is
Dividing them

V. B. MUNSON, SUCCESSOR TO
GEO. BRUCE'S SON & CO., 13 CHAMBERS STREET, NEW YORK.

STYLES 506 AND 509.

5 a 3 A—20 lb. 4 oz.

72-POINT CONDENSED BLACK, No. 506.

\$12.95.

The Athenæum

5 a 3 A—29 lb. 2 oz.

96-POINT CONDENSED BLACK, No. 506.

\$17.50.

Telegraph

5 a 3 A—33 lb.

96-POINT BLACK OPEN, No. 509.

\$19.80.

The Mail

V. B. MUNSON, SUCCESSOR TO
GEO. BRUCE'S SON & CO., 13 CHAMBERS STREET, NEW YORK.

STYLE 507.

40 a 14 A—3 lb. 4 oz. 10-POINT CONDENSED BLACK, No. 507. \$4.20.

The love of Athenais and Hermas was like a Stream that sinks out of sight
for a time in a rocky place, but springs to light again, brighter 123

30 a 10 A—3 lb. 8 oz. 12-POINT CONDENSED BLACK, No. 507. \$4.05.

And fuller than ever, in a Green Meadow. As boy and girl
they had constructed many a mud pie together 123

25 a 8 A—4 lb. 12 oz. 18-POINT CONDENSED BLACK, No. 507. \$4.75.

And Loved each other among the Jasmine and Lilies
along the shaded banks of the Bigosh 123

20 a 8 A—7 lb. 2 oz. 22-POINT CONDENSED BLACK, No. 507. \$6.40.

When Athenais entered the House of Golden
Pillars a bride the music of life 123

20 a 7 A—9 lb. 2 oz. 28-POINT CONDENSED BLACK, No. 507. \$7.85.

Came with her, the bliss of the home
unfolding like a flower 123

15 a 6 A—10 lb. 8 oz. 36-POINT CONDENSED BLACK, No. 507. \$8.60.

When a Child came to them, a
strong, beautiful Boy 12

V. B. MUNSON, SUCCESSOR TO
GEO. BRUCE'S SON & CO., 13 CHAMBERS STREET, NEW YORK.

STYLE 508.

40 a 14 A—2 lb. 12 oz. 10-POINT BLACK OPEN, No. 508. \$3.55.

He saw the Shapeless Terror that was moving toward him, but He was
Powerless to stay its approach or to escape it 123

30 a 10 A—2 lb. 14 oz. 12-POINT BLACK OPEN, No. 508. \$3.35.

A bar of sun-warmed shingle where a man may bask and loaf
to the click of shod canoe-poles round the bend 123

25 a 8 A—4 lb. 2 oz. 18-POINT BLACK OPEN, No. 508. \$4.10.

To a silent smoky Indian that we know, To a couch of
new-pulled hemlock with the Starlight 123

25 a 8 A—6 lb. 2 oz. 22-POINT BLACK OPEN, No. 508. \$5.50.

Do you know the Shallow Baltic, where the
seas are Quick and Short 123

20 a 7 A—8 lb. 2 oz. 28-POINT BLACK OPEN, No. 508. \$7.00.

He can take his chance of Drowning
while I sail and sail her 12

15 a 6 A—10 lb. 36-POINT BLACK OPEN, No. 508. \$8.20.

When the blazoned, bird-winged
Butterflies flap thro' 12

V. B. MUNSON, SUCCESSOR TO
GEO. BRUCE'S SON & CO., 13 CHAMBERS STREET, NEW YORK.

STYLE 511.

5 a 3 A—27 lb. 14 oz.

84-POINT MODERN TEXT OPEN, No. 511.

\$16.70.

The Budget

5 a 3 A—34 lb. 8 oz.

96-POINT MODERN TEXT OPEN, No. 511.

\$20.70.

Chronicle

5 a 3 A—46 lb.

120-POINT MODERN TEXT OPEN, No. 511.

\$26.70.

Tribune

V. B. MUNSON, SUCCESSOR TO
GEO. BRUCE'S SON & CO., 13 CHAMBERS STREET, NEW YORK.

STYLES 510 AND 512.

5 a 3 A—30 lb. 10 oz.

96-POINT MODERN TEXT, No. 510.

\$18.40.

Mercury

5 a 3 A—46 lb.

120-POINT MODERN TEXT, No. 510.

\$26.70.

Weekly

5 a 3 A—53 lb. 8 oz.

132-POINT BLACK ORNAMENTED, No. 512.

\$29.95.

Whirling

V. B. MUNSON, SUCCESSOR TO
GEO. BRUCE'S SON & CO., 13 CHAMBERS STREET, NEW YORK.

STYLE 513.

60 a 20 A—3 lb. 14 oz. 8-POINT EXTENDED BLACK, No. 513. \$6.20.

While strolling down the street last eve, upon mere pleasure bent,
'Twas after business worries of the day 1234567890

40 a 14 A—4 lb. 4 oz. 10-POINT EXTENDED BLACK, No. 513. \$5.50.

Just a little bit off the Top for me, for me, for me, A
little bit off the Top for me, for me 123456

30 a 10 A—4 lb. 12 oz. 12-POINT EXTENDED BLACK, No. 513. \$5.50.

Chop me off a Yard or two, or two -- I'll tell
you when to stop, to stop 12345

25 a 8 A—8 lb. 18-POINT EXTENDED BLACK, No. 513. \$8.00.

All I want is a small portion
off the Top, the Top 123

20 a 7 A—12 lb. 24-POINT EXTENDED BLACK, No. 513. \$10.80.

She was Bred in Old
Kentucky 1234

15 a 6 A—20 lb. 6 oz. 36-POINT EXTENDED BLACK, No. 513. \$16.70.

She was Pie in
New Orleans

V. B. MUNSON, SUCCESSOR TO
GEO. BRUCE'S SON & CO., 13 CHAMBERS STREET, NEW YORK.

STYLES 514 AND 529.

25 a 8 A—8 lb.

18-POINT EXTENDED BLACK OPEN, No. 514.

\$8.00.

She was Cake in Cincinnati, in
Boston Pork and Beans 12

20 a 7 A—12 lb.

24-POINT EXTENDED BLACK OPEN, No. 514.

\$10.80.

When the sisters dance
a ballet to church 12

15 a 6 A—20 lb. 4 oz.

36-POINT EXTENDED BLACK OPEN, No. 514.

\$16.60.

Most demurely
patterned 12

15 a 6 A—8 lb. 8 oz.

24-POINT BLACK RAY SHADED, No. 529.

\$7.65.

That dances honey-pale
upon the moon

10 a 4 A—11 lb. 8 oz.

36-POINT BLACK RAY SHADED, No. 529.

\$9.45.

Chill our flushed
dreamlets

V. B. MUNSON, SUCCESSOR TO
GEO. BRUCE'S SON & CO., 13 CHAMBERS STREET, NEW YORK.

STYLES 515 AND 651.

20 a 7 A—4 lb. 12 oz.

24-POINT TEXT, No. 515.

\$4.25.

She rules her Rugged Hilltops and her Breathless Groves of
Galm, and whether in Waste or City 1234

15 a 6 A—7 lb. 12 oz.

36-POINT TEXT, No. 515.

\$6.35.

With Freedom her Shining Shield 123

12 a 5 A—11 lb. 12 oz.

48-POINT TEXT, No. 515.

\$8.45.

Queen by right of her Might 12

30 a 15 A—4 lb. 6 oz.

12-POINT PAINT BRUSH, No. 651.

\$5.10.

AT NIGHT, IN SOME LITTLE
Meagre mountain town we stroll about 12345

25 a 12 A—6 lb. 6 oz.

18-POINT PAINT BRUSH, No. 651.

\$6.35.

NARROWLY ESCAPED
Arrest for starting a crap game 123

25 a 12 A—9 lb. 12 oz.

22-POINT PAINT BRUSH, No. 651.

\$8.75.

PRESENTLY COMES
A young priest, in black 123

V. B. MUNSON, SUCCESSOR TO
GEO. BRUCE'S SON & CO., 13 CHAMBERS STREET, NEW YORK.

STYLES 516 AND 517.

25 a 8 A—5 B.

22-POINT BLACK ORNATE, No. 516.

\$4.50.

Near the mound where he was supposed to lie, a Great
Vine of English Ivy had grown over a
low, red-tiled House, which, with its quaintly

20 a 7 A—7 B.

28-POINT BLACK ORNATE, No. 516.

\$6.00.

Pitched Roofs and squat white Chimneys,
closed in the fourth side of the
Hotel, the side once open for Garden

25 a 8 A—5 B.

22-POINT BLACK ORNATE SHADED, No. 517.

\$4.50.

It was "brabe," as Madame Guano called it, with a few
yards of turf, a great mulberry tree that
stretched one gaunt arm across to the ivy-covered

20 a 7 A—6 B. 12 oz.

28-POINT BLACK ORNATE SHADED, No. 517.

\$5.80.

Wall, a patch or two of Flowers, and little
Iron Tables where the Women
took coffee when the Sun was shining

V. B. MUNSON, SUCCESSOR TO
GEO. BRUCE'S SON & CO., 13 CHAMBERS STREET, NEW YORK.

20 a 7 A—12 lb. 6 oz. 28-POINT TEUTONIC ORNAMENTED, No. 518.

\$10.65.

Not being a bloodthirsty man
he pondered much on
these things, and after 12

15 a 6 A—14 lb. 10 oz. 36-POINT TEUTONIC ORNAMENTED, No. 518.

\$12.00.

Years of awful Dorry,
he decided that he
had better fly de coop 3

12 a 5 A—25 lb. 4 oz. 48-POINT TEUTONIC ORNAMENTED, No. 518.

\$18.20.

He flew and never
came back
Is flying yet 3

STYLES 519 AND 520.

25 a 8 A—6 lb. 12 oz.

18-POINT SAXON ORNATE, No. 519.

\$6.75.

Our New Possessions in Pacific Ocean 12

20 a 7 A—10 lb. 8 oz.

24-POINT SAXON ORNATE, No. 519.

\$9.45.

National Expansion Desirable 12

15 a 6 A—15 lb. 4 oz.

36-POINT SAXON ORNATE, No. 519.

\$12.50.

America vs. Aguinaldo 12

25 a 8 A—6 lb. 12 oz.

18-POINT SAXON ORNATE SHADED, No. 520.

\$6.75.

School for Education of Young Women 12

20 a 7 A—10 lb. 8 oz.

24-POINT SAXON ORNATE SHADED, No. 520.

\$9.45.

Harvest Home Festival Fight 12

15 a 6 A—15 lb. 4 oz.

36-POINT SAXON ORNATE SHADED, No. 520.

\$12.50.

Put Me off at Buffalo 12

V. B. MUNSON, SUCCESSOR TO
GEO. BRUCE'S SON & CO., 13 CHAMBERS STREET, NEW YORK.

25 a 8 A—5 lb. 2 oz. 18-POINT SAXON ORNATE SHADED, No. 521.

\$5.10.

Story of the Merry Mariners of the Mary
By One of Them 34

20 a 7 A—7 lb. 12 oz. 24-POINT SAXON ORNATE SHADED, No. 521.

\$6.95.

My Hilarious Visit at Exbridge
By Bill Harrison 12

15 a 6 A—12 lb. 8 oz. 36-POINT SAXON ORNATE SHADED, No. 521.

\$10.25.

The Sailor's Confession
By Douglass 12

12 a 5 A—13 lb. 4 oz. 44-POINT SAXON ORNATE SHADED, No. 521.

\$10.35.

Wow! What's on Mac
By Mack 12

V. B. MUNSON, SUCCESSOR TO
GEO. BRUCE'S SON & CO., 13 CHAMBERS STREET, NEW YORK.

STYLES 522 AND 526.

30 a 10 A—4 lb. 8 oz.

18-POINT ITALIAN TEXT, No. 522.

\$4.50.

Through stormy and sunlit Days still shall the crescent pages of
History sing her praise—The White Republic

20 a 7 A—6 lb. 12 oz.

28-POINT ITALIAN TEXT, No. 522.

\$5.80.

Sons who learned to love her and of loving her learned
to Die for the Flag of the White Republic

20 a 7 A—4 lb.

24-POINT EXTRA CONDENSED BLACK, No. 526.

\$3.60.

But Winter is the Monarch of the Year, when Wild Winds make the
Giant Pines their Harp, and entertain the Gods 123456

15 a 6 A—6 lb. 2 oz.

36-POINT EXTRA CONDENSED BLACK, No. 526.

\$5.00.

Only to those who miss a Presence dear the thorns of
Winter's holly-crown are Sharp 1234567

12 a 5 A—9 lb. 8 oz.

48-POINT EXTRA CONDENSED BLACK, No. 526.

\$6.85.

And all its Berries gleam like Drops 14

V. B. MUNSON, SUCCESSOR TO
GEO. BRUCE'S SON & CO., 13 CHAMBERS STREET, NEW YORK.

STYLE 523.

20 a 8 A—8 lb. 8 oz.

22-POINT TEUTONIC SHADED, No. 523.

\$7.65.

The Thistle, Shamrock, Rose entwine the
Maple Leaf forever 1234

20 a 7 A—12 lb. 8 oz.

28-POINT TEUTONIC SHADED, No. 523.

\$10.75.

Spring has her Varied Skies,
her Waking Leaves 123

15 a 6 A—14 lb. 4 oz.

36-POINT TEUTONIC SHADED, No. 523.

\$11.70.

Summer her lavish dower
of bloom and balm 12

10 a 4 A—24 lb. 2 oz.

48-POINT TEUTONIC SHADED, No. 523.

\$17.40.

Autumn days of
calmness 12

V. B. MUNSON, SUCCESSOR TO
GEO. BRUCE'S SON & CO., 13 CHAMBERS STREET, NEW YORK.

25 a 8 A
7 lb. 12 oz.

18-POINT ITALIAN BLACK ORNAMENTED, No. 525.

\$7.75.

Second Annual Athletic Meeting
of the Hayseed Harriers
Turnipville, December 1, 1899

20 a 7 A
11 lb. 4 oz.

24-POINT ITALIAN BLACK ORNAMENTED, No. 525.

\$10.10.

Celebrated Semper Paratus
Female Orchestra
Calliope Solos on Tap

15 a 6 A
17 lb. 6 oz.

36-POINT ITALIAN BLACK ORNAMENTED, No. 525.

\$14.25.

Biscuit, Cheese and
Beer ad lib
Frankfurter 5cts.

V. B. MUNSON, SUCCESSOR TO
GEO. BRUCE'S SON & CO., 13 CHAMBERS STREET, NEW YORK.

STYLES 530 AND 531.

20 a 7 A—5 lb. 6 oz.

24-POINT MONOGRAM, No. 530.

\$4.85.

Of Pilgrim Eyes Provisioned and Puritan Lips 123

15 a 6 A—8 lb. 2 oz.

36-POINT MONOGRAM, No. 530.

\$6.65.

Foretold, Dowered with the Wealth of 12

12 a 5 A—12 lb. 12 oz.

48-POINT MONOGRAM, No. 530.

\$9.25.

Woodland, Glory of Virgin 12

20 a 7 A—5 lb. 6 oz.

24-POINT MONOGRAM, No. 531.

\$4.85.

AWOKE THE WHITE REPUBLIC, THE GIFT OF THE LORD 123

15 a 6 A—8 lb. 4 oz.

36-POINT MONOGRAM, No. 531.

\$6.75.

AS BROAD AND FREE AS THE BORDERS 12

12 a 5 A—13 lb.

48-POINT MONOGRAM, No. 531.

\$9.35.

THE LIGHT OF HER OPTICS 12

CUSTOMERS DESIRING BOTH OF THESE STYLES, NEED ORDER ONLY ONE FONT
OF THE CAPITALS.

V. B. MUNSON, SUCCESSOR TO
GEO. BRUCE'S SON & CO., 13 CHAMBERS STREET, NEW YORK.

STYLE 532.

20 a 7 A—7 lb. 8 oz.

24-POINT BLACK ORNAMENTED, No. 532.

\$6.75.

Annual Commencement Exercises

Demill College

Lecture Hall

Light o'clock

15 a 6 A—12 lb. 2 oz.

36-POINT BLACK ORNAMENTED, No. 532.

\$9.95.

Restaurant de Mermaid

Table d'Hôte

Brewster's Room

12 a 5 A—18 lb. 12 oz.

48-POINT BLACK ORNAMENTED, No. 532.

\$13.50.

American Hotel

Wallabond

V. B. MUNSON, SUCCESSOR TO
GEO. BRUCE'S SON & CO., 13 CHAMBERS STREET, NEW YORK.

STYLES 533 AND 537.

20 a 7 A—8 lb. 10 oz.

24-POINT BLACK RIMMED, No. 533.

\$7.75.

Pursues the priceless guerdon
at a reckless gait

15 a 6 A—11 lb. 8 oz.

36-POINT BLACK RIMMED, No. 533.

\$9.45.

Arrived at four and had
to wait till eight

20 a 7 A—5 lb. 2 oz.

18-POINT BLACK ORNAMENTED, No. 537.

\$5.10.

The Mother of Loyal Daughters, whose
giraffe and guard are these 123

15 a 6 A—8 lb. 4 oz.

24-POINT BLACK ORNAMENTED, No. 537.

\$7.40.

The leagues of inland waters
filled with live sardines 12

10 a 4 A—11 lb. 8 oz.

36-POINT BLACK ORNAMENTED, No. 537.

\$9.45.

Mountains of dusky
diamonds 123

V. B. MUNSON, SUCCESSOR TO
GEO. BRUCE'S SON & CO., 13 CHAMBERS STREET, NEW YORK.

STYLE 534.

30 a 10 A—3 lb. 8 oz. 12-POINT LITHOGRAPHIC BLACK, No. 534.

\$4.05.

Flags and various other things were flying far and
near, The drums were gaily
tapped, as well as numerous kegs of beer

25 a 8 A—5 lb. 14 oz. 18-POINT LITHOGRAPHIC BLACK, No. 534.

\$5.90.

The hoot-beats of the dead beats as
they hustled for their share
Filled the room and floated out

20 a 7 A—9 lb. 8 oz. 24-POINT LITHOGRAPHIC BLACK, No. 534.

\$8.55.

Upon the whisky-flavored
air, The band played
Will You Love Me When

15 a 6 A—13 lb. 12 oz. 36-POINT LITHOGRAPHIC BLACK, No. 534.

\$11.25.

The Leaves Begin to
Turn, and the
people climbed up

V. B. MUNSON, SUCCESSOR TO
GEO. BRUCE'S SON & CO., 13 CHAMBERS STREET, NEW YORK.

25 a 8 A—8 lb. 14 oz. 22-POINT BLACK RIM SHADED, No. 535.

\$8.00.

**Each to the other plighted till the
end of Time they stand 123**

20 a 7 A—11 lb. 4 oz. 28-POINT BLACK RIM SHADED, No. 535.

\$9.65.

**Palmetto to Pine united and
Prairie to Pasture 12**

15 a 6 A—14 lb. 4 oz. 36-POINT BLACK RIM SHADED, No. 535.

\$11.70.

**And the Deeds and the
Deaths of Men 3**

12 a 5 A—19 lb. 6 oz. 48-POINT BLACK RIM SHADED, No. 535.

\$14.00.

**And on through the
unrun ages 12**

V. B. MUNSON, SUCCESSOR TO
GEO. BRUCE'S SON & CO., 13 CHAMBERS STREET, NEW YORK.

STYLES 524 AND 538.

20 a 7 A—5 lb. 12 oz.

22-POINT MEDIEVAL, No. 524.

\$5.20.

Christmas Day was dawning o'er New York
ninety years ago, and as the curtain of
night drew softly upward along the edge 12

30 a 10 A—4 lb.

12-POINT BLACK ORNAMENTED, No. 538.

\$4.65.

Of the sky, the rugged crest of Mount Konkers
stood outlined with pale light 123

25 a 8 A—5 lb. 14 oz.

18-POINT BLACK ORNAMENTED, No. 538.

\$5.85.

The great City lay half asleep, still
multitudes of Christians 123

20 a 7 A—9 lb. 6 oz.

24-POINT BLACK ORNAMENTED, No. 538.

\$8.40.

Robed in white and bearing
lighted torches 123

15 a 6 A—14 lb. 12 oz.

36-POINT BLACK ORNAMENTED, No. 538.

\$12.10.

Were hustling down
to the Battery 12

V. B. MUNSON, SUCCESSOR TO
GEO. BRUCE'S SON & CO., 13 CHAMBERS STREET, NEW YORK.

STYLE 539.

25 a 8 A—4 lb. 8 oz.

18-POINT BLACK ORNAMENTED, No. 539.

\$4.50.

There was the old time Fire-eater, with eyes that flame and
flash, who haunts the ever closing drink, and
sports a White Monstache, Who's on his uppers 123

20 a 7 A—7 lb. 2 oz.

24-POINT BLACK ORNAMENTED, No. 539.

\$6.40.

All the time, though feeling spick and span,
While on his proud and jaunty air
no fate can lay the ban; Yes, he was 12

15 a 6 A—11 lb. 6 oz.

36-POINT BLACK ORNAMENTED, No. 539.

\$9.35.

There and full of life; he dreamt
of Lees and Clays 123

12 a 5 A—17 lb. 6 oz.

48-POINT BLACK ORNAMENTED, No. 539.

\$12.50.

A reminiscent figure of
ante-bellum days 4

V. B. MUNSON, SUCCESSOR TO
GEO. BRUCE'S SON & CO., 13 CHAMBERS STREET, NEW YORK.

STYLE 540.

60 a 20 A—3 lb. 10 oz. 8-POINT VICTORIA, No. 540. \$5.80.

NOTHING IS MORE DELIGHTFUL TO A BENEVOLENT MIND
Than the sight of human happiness, and the traveller who beholds it in any country
will by the sympathy of nature share in the felicity 1234

40 a 14 A—2 lb. 12 oz. 10-POINT VICTORIA, No. 540. \$3.60.

EVERY TRAVELLER IN THIS COUNTRY WILL HAVE
His feelings powerfully excited by seeing the happiest people on earth, whose
prospects are unbounded. Heaven, ever propitious to 123

30 a 10 A—3 lb. 10 oz. 12-POINT VICTORIA, No. 540. \$4.20.

AMERICA, CROWNS THE YEAR WITH
Health and plenty, and we everywhere behold the vivid
countenance and the smile of joy 123

25 a 8 A—5 lb. 6 oz. 18-POINT VICTORIA, No. 540. \$5.35.

THE OLD-TIME QUERY AND
Complaint "Why were former days better than
these" is not heard in the land 12

25 a 8 A—9 lb. 4 oz. 22-POINT VICTORIA, No. 540. \$8.30.

"OUT OF THE HEART
The mouth speaketh," and there 12

20 a 7 A—11 lb. 28-POINT VICTORIA, No. 540. \$9.45.

IS A FEELING OF
Contentment and a glow of 12

V. B. MUNSON, SUCCESSOR TO
GEO. BRUCE'S SON & CO., 13 CHAMBERS STREET, NEW YORK.

30 a 10 A—3 lb. 6 oz. 12-POINT BLACK ORNAMENTED, No. 542.

\$3.90.

Charles the Second ate a chop there with Nell Gwynne.
A brass tablet in one corner informs you that this was the favorite
seat of Dr. Samuel Johnson,
And the panelling immediately below is quite polished by the
heads of generations of the faithful.

25 a 8 A—4 lb. 12 oz. 18-POINT BLACK ORNAMENTED, No. 542.

\$4.75.

Goldsmith, Pope, Congreve, De Quincy,
Chackerau, Dickens, Leech, Douglas Jerrold and
Tom Hood were among its frequenters.

20 a 7 A—7 lb. 8 oz. 24-POINT BLACK ORNAMENTED, No. 542.

\$6.75.

There are authentic legends that
Shakespeare spent many hours here, being
near his theatre in Playhouse Yard.

15 a 6 A—11 lb. 10 oz. 36-POINT BLACK ORNAMENTED, No. 542.

\$9.55.

The old Cheshire Cheese, an
ancient resort in London.

STYLE 543.

30 a 10 A—3 lb.

12-POINT BLACK ORNAMENTED, No. 543.

\$3.50.

The ease of manner and appearance of satisfaction which
pervade a Well-dressed Woman arise from a confidence in her own
attractiveness. Her toilet is winning,
because it is becoming and fresh, and her womanly
instinct is responsible for its becomingness 1234567890

25 a 8 A—4 lb. 4 oz.

18-POINT BLACK ORNAMENTED, No. 543.

\$4.25.

Sometimes it strikes you with Wonder, sometimes
with instant Delight, as of love at first sight,
but in either case it is Indefinable 123

20 a 7 A—6 lb. 14 oz.

24-POINT BLACK ORNAMENTED, No. 543.

\$6.20.

Inexpressible, except Approximately
and by Comparisons,
like the Flavor of a Peach 1234

15 a 6 A—10 lb. 12 oz.

36-POINT BLACK ORNAMENTED, No. 543.

\$8.80.

On the Scent of Violets, or a
perfume-laden breeze 12

V. B. MUNSON, SUCCESSOR TO
GEO. BRUCE'S SON & CO., 13 CHAMBERS STREET, NEW YORK.

STYLE 544.

30 & 10 A—3 lb. 8 oz. 12-POINT BLACK ORNAMENTED, No. 544.

\$4.05.

In and out of the lights they passed him, vague impressions of
filmy draperies and lantern-lit faces, with 123456

25 & 8 A—5 lb. 4 oz. 18-POINT BLACK ORNAMENTED, No. 544.

\$5.25.

Now and then a shadowy gesture or a sparkle of
laughing eyes in the twilight 123456

20 & 7 A—8 lb. 24-POINT BLACK ORNAMENTED, No. 544.

\$7.20.

Beyond, the dark foliage of sycamore
and maple loomed, motionless 12

15 & 6 A—12 lb. 36-POINT BLACK ORNAMENTED, No. 544.

\$9.85.

With never a puff of wind to
stir the tender leaves 12

5 & 5 A—13 lb. 8 oz. 48-POINT BLACK ORNAMENTED, No. 544.

\$9.70.

There were others;
one or two 123

V. B. MUNSON, SUCCESSOR TO
GEO. BRUCE'S SON & CO., 13 CHAMBERS STREET, NEW YORK.

STYLE 580.

25 a 8 A—5 lb.

18-POINT GERMAN TEXT, No. 580.

\$5.00.

To the Chinese is generally conceded the credit for the earliest invention and use of Printing.

The claim is valid, and the priority of the Celestial Empire in the Art seems to be fairly well established 12345

25 a 8 A—8 lb.

22-POINT GERMAN TEXT, No. 580.

\$7.20.

If the taking of Impressions from an Engraved Plate be accounted an achievement of sufficient importance. This was first accomplished by one Shoo Fred Wung Gimms 12345

12 a 5 A—12 lb. 3 oz.

40-POINT GERMAN TEXT, No. 580.

\$9.50.

Medieval Kings and Princes,
among them William the
Conqueror, had their monograms
cut on blocks of wood 1234

STYLE 580.

5 a 3 A—16 lb.

48-POINT GERMAN TEXT, No. 580.

\$11.50.

In Testimony whereof
We now know We

5 a 3 A—30 lb.

84-POINT GERMAN TEXT, No. 580.

\$18.00.

In Witness
Whereof

5 a 3 A—52 lb.

120-POINT GERMAN TEXT, No. 580.

\$30.15.

Records

V. B. MUNSON, SUCCESSOR TO
GEO. BRUCE'S SON & CO., 13 CHAMBERS STREET, NEW YORK.

STYLES 644, 647 AND 648.

60 a 30 A 30 A 5-POINT ENGRAVERS' HAIR-LINE, No. 644. \$4.90.
1 lb. 12 oz.

WESTWARD OF THE STREAM, WHERE WE ARE LYING, THE BANKS ROLL UP SWIFTLY
Into sloping hills, covered with groves of oak and green pasture lands, dotted with mossy rocks. And farther on,
where some wood has been swept down, some ten years gone, by the axe, the new growth,
heavy with the luxuriant foliage of spring, covers wide spots of the
SLANTING LAND, WHILE SOME DEAD TREE IN THE MIDST STILL STRETCHES OUT ITS BARE ARMS TO THE
BLAST, A SOLITARY MOURNER OVER THE WRECK OF ITS FOREST BROTHERS 1234567890

60 a 30 A 30 A 6-POINT ENGRAVERS' HAIR-LINE, No. 644. \$6.00.
3 lb.

TO EASTWARD THE RIDGY BANK PASSES INTO WAVY MEADOWS
Upon whose farther edge you see the roofs of an ancient mansion, with tall chimneys and
taller elm trees shading it. Beyond, the hills rise gradually, like
the hired man in the morning, and 1234567890
SWEEP AWAY INTO WOOD-CROWNED HEIGHTS THAT ARE BLUE WITH DISTANCE, ETC.

40 a 20 A 30 A 10-POINT ENGRAVERS' HAIR-LINE, No. 644. \$4.70.
3 lb. 10 oz.

AT THE UPPER END OF THE VALLEY THE STREAM
Is lost to the eye in a wide swamp wood, which in the autumn time is covered
with a scarlet sheet, blotched here and there by the
DARK CRIMSON OR NAVY BLUE STAINS OF THE ASH-TOPS 1234

30 a 15 A—2 lb. 12-POINT CONDENSED HAIR-LINE, No. 647. \$2.30.

FARTHER ON, THE HILLS CROWD CLOSE TO THE BROOK, AND COME DOWN
With granite boulders and scattered birch trees and beeches, under which, upon the smoky mornings
of May, I have time and again loitered, and thrown my line into
the dark still pools, only to find that the fish were somewhere else 1234567890

30 a 15 A—3 lb. 2 oz. 12-POINT HAIR-LINE SHADED, No. 648. \$3.65.

BELOW, AND LOOKING SOUTHWARD THROUGH THE
Openings of the huge oaks that shade me, I see a broad stretch of
meadow, with glimpses of the silver surface
of the stream, the giant solitary elms, and of several
other things not necessary to mention 12345

V. B. MUNSON, SUCCESSOR TO
GEO. BRUCE'S SON & CO., 13 CHAMBERS STREET, NEW YORK.

STYLES 645 AND 650.

40 a 20 A—3 lb. 14 oz. 10-POINT ITALIC HAIR-LINE, No. 645. \$5.05.

*SIXTY YEARS AGO, THEY TELL ME, MY FATHER -
Used to loiter here with his gun, while his hounds lay around under
the scattered oaks. Now he sleeps in the little grave-
yard yonder, where I can see the 1284*

30 a 15 A—4 lb. 10 oz. 12-POINT ITALIC HAIR-LINE, No. 645. \$5.35.

*WHITE TABLETS GLIMMERING
Through the foliage. I never knew him. He
died at the age of twenty-six 128*

40 a 20 A—3 lb. 8 oz. 10-POINT VENETIAN, No. 650. \$4.55.

*OTHER FEET HAVE TROD UPON THIS KNOLL
Far more dear to me. The older neighbors have sometimes told me
how they have seen, forty years ago 1234567890*

30 a 15 A—3 lb. 14 oz. 12-POINT VENETIAN, No. 650. \$4.50.

*TWO PRETTY ROSY-CHEEKED GIRLS
Idling on this spot, under the shade, gathering acorns
and making oak=leaf garlands 123*

25 a 12 A—6 lb. 18-POINT VENETIAN, No. 650. \$6.00.

*FOR THEIR FOREHEADS
Alas, Alas! The garlands they wear now are
not earthly garlands 1234*

V. B. MUNSON, SUCCESSOR TO
GEO. BRUCE'S SON & CO., 13 CHAMBERS STREET, NEW YORK.

STYLE 652.

40 & 14 A—4 lb. 4 oz. 10-POINT MADISONIAN, No. 652. \$5.50.

*And together we go down into Savoy to that marvellous
valley under the shoulder of Mont Blanc 1234*

33 & 10 A—4 lb. 4 oz. 12-POINT MADISONIAN, No. 652. \$4.95.

*Or we wander over the Mer de Glace, and pick Alpine
roses from the edge of the frowning glacier 123*

25 & 8 A—6 lb. 4 oz. 18-POINT MADISONIAN, No. 652. \$6.25.

*We toil at nightfall up to the monastery of
the great St. Bernard, where 123*

25 & 8 A—10 lb. 10 oz. 22-POINT MADISONIAN, No. 652. \$9.55.

*The ice crackles in the foot-path,
the cold moon glistens 123*

15 & 6 A—21 lb. 36-POINT MADISONIAN, No. 652. \$17.20.

*Arrah, go on; you're
only fooling 12*

12 & 5 A—30 lb. 48-POINT MADISONIAN, No. 652. \$21.60.

New Haven 17

V. B. MUNSON, SUCCESSOR TO
GEO. BRUCE'S SON & CO., 13 CHAMBERS STREET, NEW YORK.

STYLE 680.

40 a 20 A—3 lb. 10-POINT SHOW CARD, No. 680. \$3.90.

AGAIN, WE ARE AMONG THE GRANITE HEIGHTS
Whose ledges are filled with ice, upon the Grimsel. The pond is dark and
cold; the paths are slippery and winding 1234567890

30 a 15 A—3 lb. 8 oz. 12-POINT SHOW CARD, No. 680. \$4.05.

THE GREAT GLACIER OF THE AAR
Sends down icy breezes, and the echoes ring from rock to rock
as if the ice-God answered 123456

25 a 12 A—6 lb. 18-POINT SHOW CARD, No. 680. \$6.00.

LISTEN TO THE MELODIOUS
Rolling tongue of the Venetian gondolier, as he
sings his morning song 123

20 a 10 A—8 lb. 10 oz. 24-POINT SHOW CARD, No. 680. \$7.75.

SQUARE TOWERS
Pyramidal tops, clustered domes 4

15 a 8 A—14 lb. 8 oz. 36-POINT SHOW CARD, No. 680. \$11.90.

MAKING (and) breaking 4

5 a 5 A—14 lb. 12 oz. 48-POINT SHOW CARD, No. 680. \$10.60.

BILL of Lading 4

V. B. MUNSON, SUCCESSOR TO
GEO. BRUCE'S SON & CO., 13 CHAMBERS STREET, NEW YORK.

STYLE 681.

30 & 10 A—2 lb. 10 oz.

12-POINT ENGROSSING, No. 681.

\$3.05.

*We glide nearer and nearer to the floating wonder, under the silent working oar of our now
silent gondolier, and we ride up swiftly under the deep, broad shadows of
palaces, and see plainly the play of the sea water in the crevices of the masonry;
and we turn into narrow rivers 1234567890*

25 & 8 A—4 lb. 2 oz.

18-POINT ENGROSSING, No. 681.

\$4.10.

*Shaded darkly by overhanging walls, hearing no sound but of voices,
or the swaying of the water against the houses
And the mystic fingers of the Past, grappling our spirits 1234*

20 & 7 A—6 lb. 8 oz.

24-POINT ENGROSSING, No. 681.

\$5.85.

*Lead them away, willing and rejoicing captives thro'
the long vista of the ages that are past 12345*

15 & 6 A—10 lb. 4 oz.

36-POINT ENGROSSING, No. 681.

\$8.40.

*Upon the narrow Island we found
many Jewish graves 12345*

12 & 5 A

48-POINT ENGROSSING, No. 681.

\$11.50.

*Nearly covered with drifts
of shifting sand 123*

V. B. MUNSON, SUCCESSOR TO
GEO. BRUCE'S SON & CO., 13 CHAMBERS STREET, NEW YORK.

STYLES 682 AND 683.

60 a 30 A—14 lb.

18-POINT CIRCULAR, No. 682.

\$14.00.

THE CURTAIN OF NIGHT DREW

*Softly upward along the edge of the sky, and the ragged crests
of Mount Silpius stood outlined 12345*

60 a 30 A—14 lb.

22-POINT CIRCULAR, No. 682.

\$12.60.

IN THE DARK VAULT

*Of the central heavens larger stars still
glimmered drowsily 123*

30 a 10 A—2 lb. 4 oz.

12-POINT BORUSSIAN, No. 683.

\$2.60.

Just two hundred and seventy-eight years ago the Pilgrim Fathers celebrated Thanksgiving, in grateful acknowledgment of the first harvest in the colonies. New England has practically monopolized the Thanksgiving holiday 1234567890

25 a 8 A—3 lb. 4 oz.

18-POINT BORUSSIAN, No. 683.

\$3.25.

For nearly two centuries. New York State's first official recognition of the day was in 1817. Virginia recognized the day officially in 1857, and in the following year eight of the 1234567890

20 a 7 A—5 lb. 4 oz.

24-POINT BORUSSIAN, No. 683.

\$4.75.

Southern States proclaimed it a holiday. "We" will "recognize" it to-morrow, November 30, 1899

V. B. MUNSON, SUCCESSOR TO
GEO. BRUCE'S SON & CO., 13 CHAMBERS STREET, NEW YORK.

REGAL ITALIC

36 POINT

4 A 8 a \$6 50

HIRE Domestics

30 POINT

5 A 10 a \$8 00

Emblematic CORDS

24 POINT

6 A 12 a \$5 25

*ACHIEVEMENT
Meritorious Instruction*

18 POINT

7 A 14 a \$4 50

*MONROE DOCTRINE
Historic Document Published*

14 POINT

9 A 18 a \$4 20

*LEARNED EDUCATORS
Conclusive Academical Examination*

12 POINT

12 A 24 a \$4 00

*GYMNASIUM
Masculine Exerciser*

10 POINT

14 A 28 a \$3 50

*ORGANIZATION
Universal Peace Societies*

8 POINT

18 A 36 a \$3 00

*SURGICAL RECORDS
Scientific Theories Examined
1234567890*

6 POINT

24 A 48 a \$2 50

*INFORMATION BUREAU
Valuable Services Rendered Citizens
1234567890*

BRADLEY SERIES

60 POINT

3 A 5 a \$8 50

Leads the Style
in Black Letters

48 POINT

3 A 8 a \$6 75

Early printers were
loud in their praise

36 POINT

4 A 10 a \$5 00

Gothic went out of fashion
in Germany and France at
the end of the 16th century

BRADLEY SERIES

24 POINT

5 A 16 a \$3 50

GERMAN printers of 1450 used bold Black Letters so that they could avoid detection in their many undertakings of a hazardous nature

18 POINT

8 A 25 a \$3 25

THE pages of early books were either large or small folios, but sometimes quartos, and were therefore cumbrous and unhandy. • Aldus Manuccio, of Venice, was the first to introduce the

12 POINT

15 A 45 a \$3 00

GUTENBERG was over sixty years of age when The Dictes was printed and was notable for his industrious habit. He possessed good sound

8 POINT

18 A 52 a \$2 50

Gutenberg continued printing at Strasburg until the year 1444, when, his means being exhausted, he rejoined his uncle at Mentz. Here he renewed his experiments, and, as he needed financial assistance, secured an introduction to John Faust, a money-lender

54 POINT BRADLEY INITIALS 3 A \$4 25
SINGLE LETTER 25 CENTS

10 POINT

16 A 50 a \$2 75

FAUST and Schœffer printed the Bible, Psalter and other important works. From this rapid summary we may conclude: 1. That the merit of the invention of the art of printing, however rude it may

6 POINT

20 A 60 a \$2 25

The credit of inventing the art which perpetuates the history and achievements of all the arts and sciences has been obstinately contested, several cities having advanced rival claims to the honor of the discovery. This, however, should be no matter of surprise when we consider that the inventor of any new art, unprotected by law, would naturally endeavor to conceal its process for his own use and advantage. • After due

42 POINT BRADLEY INITIALS 3 A \$3 00
SINGLE LETTER 20 CENTS

BRADLEY ITALIC

80 POINT

3 A 5 a \$9 00

*Sound Banker
Receive Drafts*

48 POINT

3 A 7 a \$7 25

*Electrical Winder
Novel Time Clock*

36 POINT

4 A 10 a \$5 50

*Monthly Reports Given
Lombard Insurance Co.*

30 POINT

5 A 12 a \$5 00

*Quakers Welcome Visitors
Unique Patriotic Ceremony*

BRADLEY ITALIC

24 POINT

6 A 18 a \$4 50

*Fame and fortune never overtake
men in the day of their discontent*

18 POINT

9 A 26 a \$4 00

*The perilous rush of Speculators and the
Adventuresome Miner to the Gold Fields
has been overshadowed by Greater Issues*

15 POINT

12 A 36 a \$3 50

*Couched in tones of unmistakable patriotism, the
Declaration of Independence endowed the people
of the United States with privileges of the most
far-reaching importance to American citizenship*

12 POINT

14 A 40 a \$3 25

*The Laws of Progression have marked the closing of the
Nineteenth Century as the Age of Wonders. With pros-
pects of still greater attainments in the near future, the
best-thinking minds have predicted revolutions in social
and political life that will astonish the most conservative*

10 POINT

14 A 45 a \$3 00

*Pride and humility are rela-
tive terms. They suggest a
comparison of some sort with
an object higher or lower; and
the same mind may be proud*

1 2 3 4 5 6 7 8 9 0

8 POINT

16 A 48 a \$2 75

*Of two minds that possess equal
excellence, which is the noblest:
that which, however high the ex-
cellence attained by it, has some
nobler excellence in view; or that
which thinks only of those who*

1 2 3 4 5 6 7 8 9 0

BRADLEY EXTENDED

60 POINT

3 A 4a \$10 50

**Spend your
Bank Notes
in Pleasure**

48 POINT

3 A 6a \$8 50

**Nothing would
Satisfy People
so Much as to
know a Friend**

36 POINT

4A 10a \$6 50

**Timely Hints often
Make Fortunes for
Shrewd Negotiator**

30 POINT

5A 12a \$6 00

**National Achievement
of Diplomats in recent
years Illuminates our
History with Ambition**

24 POINT

6A 16a \$5 50

**The Predominant Ideas of
Modern Requirement are
both Useful and Expedient
to the Oriental Inhabitants**

BRADLEY EXTENDED

18 POINT

10 A 28 a \$5 00

The rich soil and climate of the State of California are notably adapted to the cultivation of the grape. The delicious richness and flavor of California grapes nothing of the fruit kind equals. They grow to a large size in the vineyards and bring \$12

12 POINT

14 A 42 a \$4 00

**Sweet is the pleasure
Itself cannot spoil!
Is not true leisure
One with true toil?**

15 POINT

12 A 36 a \$4 50

The cactus plant grows quickly in this section, and is used for hedging in all places

making an impervious barrier against man and beast. The stalks of some of the plants and shrubs are of the thickness of a man's body and grow to the height of sixteen feet. One of the most serviceable and highly useful plants of California is the soap plant. The 3156

**Rest is not quitting
The busy career;
Rest is the fitting
Of self to its sphere.**

BRADLEY EXTENDED

10 POINT

16 A 48 a 83 50

Philadelphia, March 29th, 1898.

Gentlemen:

Our salesman, Mr. John Young, will call on your firm on or about the first of next month with a full line of goods for the Fall and Winter Trade. We have added a fine line of inexpensive Parisian Novelties of which we will mail you a few samples. Thanking you heartily for past favors, and hoping for a continuance of the same, we remain,

Yours truly,

Martin Rober & Co.

6 POINT

20 A 60 a 83 00

**I met him in the cars,
Where resignedly he sat;
His hair was full of dust,
And so was his cravat;
He was furthermore embellished
By a ticket in his hat.**

**The conductor touched his arm,
And awoke him from a nap;
When he gave the feeding flies
An admonitory slap,
And his ticket to the man
In the yellow-lettered cap.**

**The heads of many men
Were bobbing as in sleep,
And many babies lifted
Their voices up to weep;
While the coal-dust darkly fell
On bonnets in a heap.**

**All the while the swaying cars
Kept rumbling o'er the rail,
And the frequent whistle sent
Shrieks of anguish to the gale,
And the cinders pattered down
On the grimy floor like hail.**

8 POINT

16 A 50 a 83 25

**Office of
Washington Excursion Bureau,
No. 47 First Avenue.**

January 21st, 1901.

In obedience to the wishes of our many patrons and the general public, a Chaperone will accompany each one of our Personally Conducted Summer Tours during the forthcoming season. This new innovation will be highly appreciated by parents desiring to send young children.

For detailed account of trips, rate of fare, and other useful information, write to

**William Valentine Brown,
General Manager.**

TUDOR BLACK

72 POINT

3 A 5 a \$12 00

Dark Echo

48 POINT

5 A 8 a \$8 50

Umpires
Eight and Ten

42 POINT

4 A 12 a \$6 00

Home Run
Stole the Games

36 POINT

4 A 12 a \$5 50

Divide Among
Grand Stand Money

TUDOR BLACK

24 POINT

5 A 15 a \$4 75

Eminent Censure
Award Genius Sparingly
Nation Proves

20 POINT

5 A 15 a \$3 50

Following Afterwards
Reputation is Like the Shadow
Preceding Before

18 POINT

8 A 25 a \$3 40

Sometimes, but Not Always
Accidents that Pass for Misfortunes
Return to our Welfare

12 POINT

9 A 30 a \$2 75

Quicken Movement
The Depletion of Purse
Dead Sure Thing

10 POINT

12 A 36 a \$2 75

Photographs Hanging
Obscure Way Unfavorable
Electric Lights

8 POINT

15 A 50 a \$2 75

Blockheads are Stubborn
Wise People Change Their Minds
1 2 3 4 5 6 7 8 9 0

6 POINT

15 A 50 a \$2 25

Ambition is Pronounced a Lottery
Censure is the Tax a Man Pays to the Public
for being Eminent. Don't all Speak at Once!
1 2 3 4 5 6 7 8 9 0

LACLEDE SERIES

72 POINT

3 A 5 a \$12 00

Monumental

60 POINT

3 A 6 a \$10 00

Broken Dishes

48 POINT

4 A 7 a \$8 00

Country Residence

36 POINT

4 A 9 a \$6 25

Unique Pictures Framed

24 POINT

5 A 14 a \$4 00

*Industrious
Western Farmer*

18 POINT

5 A 18 a \$3 25

*Enchantment
Handsome Decoration*

12 POINT

7 A 24 a \$3 00

*Financial Speculation
Renowned European Negotiators
1 2 3 4 5 6 7 8 9 0*

10 POINT

9 A 30 a \$2 75

*Journalistic Conventions
Neapolitan Newspapers Represented
1 2 3 4 5 6 7 8 9 0*

60 POINT

3 A 4 a \$8 25

Denouncement

48 POINT

3 A 6 a \$6 25

Famous Workmen

36 POINT

4 A 10 a \$5 25

Determined Advertiser

30 POINT

5 A 12 a \$4 75

Reward Honest Merchants

24 POINT

6 A 18 a \$4 25

*Brave Chaplain
Receives Medal*

18 POINT

9 A 28 a \$3 75

*Wonderful Cavalcade
Marching Homeward*

12 POINT

15 A 50 a \$3 25

*Youthful Juveniles Rehearse
Dramatic Elocution Admired*

10 POINT

15 A 55 a \$3 00

*Patriotic Orators Arouse Natives
Enthusiastic Countrymen Prepare
Great Midsummer Demonstration*

8 POINT

15 A 55 a \$2 75

*Sensational News of Great Victories
and Military Achievements Eagerly
Devoured by all Patriotic Admirers*

6 POINT

15 A 60 a \$2 50

*Conservatives and Radicals Join Hands
for the Sole Purpose of Introducing Peace
on Conditions Acceptable to both Countries*

1 2 3 4 5 6 7 8 9 0

1 2 3 4 5 6 7 8 9 0

CARD MERCANTILE

30 POINT No 10

5 A \$3 00

SERIES 10

24 POINT No 9

6 A \$2 75

LONGINGS

18 POINT No 8

8 A \$2 50

MORE TYPES

12 POINT No 7

14 A \$2 00

FINE CLEAN CARD

10 POINT No 6

16 A \$1 75

UNIQUE \$32.58 DESIGNS

8 POINT No 5

18 A \$1 50

AMERICAN TYPE FOUNDERS CO.

6 POINT No 4

20 A \$1 25

CARDS AND HEADINGS ARE INVESTED
WITH FINE ARISTOCRATIC SHARPNESS

6 POINT No 3

20 A \$1 15

AND IT IS DIFFICULT IF NOT IMPOSSIBLE TO
IMAGINE HOW ANYTHING FINER EVER CAN

6 POINT No 2

22 A \$1 00

FOR IMITATING THE WORK OF STEEL ENGRAVERS THERE
CAN BE NOTHING MORE BEAUTIFUL PICKED FROM A CASE

6 POINT No 1

26 A \$1 00

THE CARD MERCANTILE SERIES IS AN ABSOLUTE NECESSITY IN MODERNIZED
COMMUNITIES WHEREIN THE PEOPLE PATRONIZE ONLY 20TH CENTURY PRINTERS

BRUCE TYPE FOUNDRY, 13 CHAMBERS STREET, NEW YORK.

REMINGTON STANDARD

12 POINT

110a \$5 25 20A 110a \$7 25

Mayew, Lose and Moan

Dear Sirs--In answer to your letter of April 3 concerning Trees. Knowing all about such things we have prepared a small booklet entitled Trees--How to Grow Them--which will be sent for the small sum of 14 cents to all farm-houses east of Timbuctoo and north of Easton. The edition contains fine engravings and wood-cuts carved on the wood of trees raised through our efforts, and is printed on hand-made paper.

Respectfully

The Hawaiian Nurseries

SMITH-PREMIER TYPEWRITER

12 POINT

108a \$4 10 20A 108a \$7 50

SALE OF VALUABLE REAL ESTATE.

Whereas, John Smith and Samantha Smith, his wife, by their deed of Trust, dated May 23d, 1890, and duly recorded in the office of the Recorder of Deeds of the City of St. Louis, State of Missouri, in book 966, page 7, conveyed to the undersigned, as trustee, following described real estate, situate in the City of St. Louis, State of Missouri, to-wit: Lot thirty-five (35) of Claggett's second division, and in block number 4468. Said lot having a front of twenty-four (24) feet on the west side of Eagon street, by a depth westwardly of one hundred and twenty

Spaces are included with each font of Typewriter

BRUCE TYPE FOUNDRY, 13 CHAMBERS STREET, NEW YORK.

YOST TYPEWRITER

12 POINT

90 a \$4 65 20 A 90 a \$6 50

We beg to call your attention to this exact imitation of Yost Typewriter Type which was made especially for "imitation" work. No expense has been spared to make this type the most perfect imitation ever placed on the market, and all engaged in doing this class of work should send their orders at once if they wish to be up to date. The font consists of eighty-four characters, complete with crossed-out letters as well as all characters on the Yost machine

10 POINT

90 a \$4 65 20 A 90 a \$6 75

Everybody seems to think that as soon as they can afford it they must go to England or Europe and "be in style." If they go abroad for the scenery, or for a change of climate, they might just as well have stayed home. For within the bounds of the United States may be found places that would put to shame the Alpine scenery, and for mildness, or severity, of climate would exceed Southern France or Northern Russia. Few people have ever seen Yellowstone Park, or the Florida Everglades or the Grand Canyon of the Colorado.

Spaces are included with each font of Typewriter

BRUCE TYPE FOUNDRY, 13 CHAMBERS STREET, NEW YORK.

WATCH THE INDEX CLOSELY IN
ORDERING, AS MANY CHANGES
HAVE BEEN MADE IN THE SCHEME,
PRICE AND BODIES. THIS APPLIES
ESPECIALLY TO SCRIPT FACES, AS
WE HAVE ADDED CARD FONTS TO
NEARLY ALL OF SAME.

BRUCE TYPE FOUNDRY.

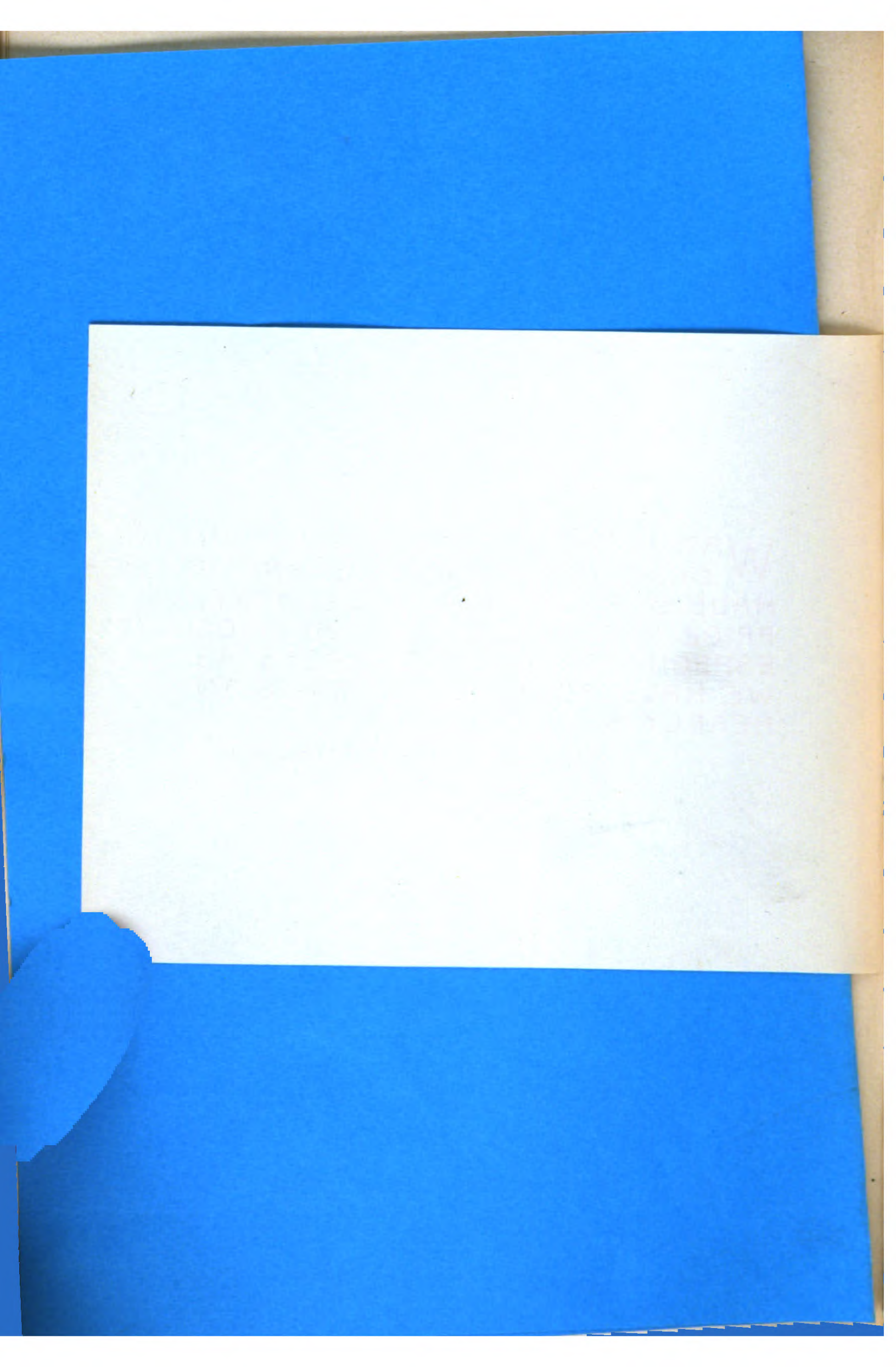

STYLE 688.

25 a 8 A—5 lb.

18-POINT CHIROGRAPH, No. 688.

\$5.00.

The first Thanksgiving of the Pilgrims was not given a permanent national status until 243 years afterwards, when, on October 20th, 1864, Abraham Lincoln, in grateful recognition of victories achieved by the

20 a 7 A—7 lb.

24-POINT CHIROGRAPH, No. 688.

\$6.30.

Union Army, and the "hopes of an ultimate and happy deliverance from all our dangers & afflictions," asked all of his fellow-citizens to join him in thanks to God 1234

15 a 6 A—10 lb. 12 oz.

36-POINT CHIROGRAPH, No. 688.

\$8.80.

Lincoln's proclamation was followed by proclamations by the Governors of the States, and this custom has been an annual one since 1864

V. B. MUNSON, SUCCESSOR TO
GEO. BRUCE'S SON & CO., 13 CHAMBERS STREET, NEW YORK.

STYLE 685.

24-POINT CALIGRAPH, No. 685.

Fonts of 15 lb.

\$13.50.

When the Revolutionary struggle ended and settlements began west of the Alleghenies it was not long before Pittsburgh, Lexington and Cincinnati became familiar with the art of printing. The annexing of the Louisiana territory did not immediately cause any great change, for the population was very sparse, and the growth of the region west of the U.S.

28-POINT CALIGRAPH, No. 685.

\$12.90.

Printing in the United States began in the year 1698 in Cambridge, Mass., the one workman being Stephen Daye, and the principal promoter being the Rev. Job Blover, who set sail with Daye and the printing material from England in that year, but unfortunately did not live until the voyage was completed. Blover's wife afterwards married Silvinger

STYLE 685.

22-POINT CALIGRAPH, No. 685.

IN FONTS OF 14 lb. 4 oz. \$12.80.

In the volume of business done in Printing in the larger cities of America the order would be New York, Chicago, Philadelphia, Boston, St. Louis, Cincinnati and Washington, the last doing chiefly Government work. Very little is done in Jersey City, Newark, Baltimore or Allegheny City in proportion to their magnitudes. Among the small cities more especially distinguished for the quantity of work turned out may be mentioned the

IN FONTS OF 30 lb. 48-POINT CALIGRAPH, No. 685.

\$21.60.

In the volume of business done in Printing in the larger Cities of America the order would be New York, Chicago, Philadelphia and

STYLE 687.

30 a 10 A—3 lb. 2 oz.

12-POINT SECRETARY, No. 687.

\$3.60.

New York State, the most populous State in the American Union, has also more printing offices and employs more workmen than any other. New York City was the first place in the State in which printing was carried on, the art having been

Albany was the second, a press beginning its work those printers who had taken up the popular side were
 ess at Fishkill, Esopus and Poughkeepsie. Presses
 e Revolution at Albany, Sag Harbor, Brooklyn,
 eekskill, Somers, Goshen, Newburgh, Poughkeepsie,
 l, Lansingburgh, Waterford, Troy, Salem, Platts-
 y, Johnstown, Herkimer, Utica, Oxford, Cazenovia,

25 a 8 A—5 lb.

18-POINT SECRETARY, No. 687.

\$5.00.

New York, the principal city in the United States, and that in which the fourth printing office in the country was established, being preceded in this respect by Cambridge, Boston and Philadelphia. The original printer was William Bradford, who had removed from Philadelphia. He began operations on April 10th, 1693, as appears from a warrant drawn upon the treasury in November of that year for six months' salary. Up to 1726 he had no rival, when John Peter Zenger, one of his

STYLE 687.

30 a 10 A—3 lb. 12 oz.

14-POINT SECRETARY, No. 687.

\$4.20.

Printing has been carried on in Scotland since 1507 or 1508, when Walter Chepman and Andrew Myllar began business in Edinburgh. They were followed by others, until in 1779 there were no fewer than twenty-seven printing offices in that city. The art was introduced into

Glasgow in 1630 by George Anderson, who was followed by Robert Faulstich in 1661. In 1740 Robert Faulstich, and the beauty of his impressions, began there. Others were first printed in Leith in 1651, Edinburgh in 1715, Aberdeen in 1748, Kelso in 1797, and

25 a 8 A—7 lb. 6 oz.

22-POINT SECRETARY, No. 687.

\$6.65.

Peter Schoeffer, one of the three persons commonly regarded as the inventors of Printing, was born about the year 1430, at Gernsheim, a little village situated on the Rhine, near Mentz. While still very young he was employed as a copyist in Paris. He was also in the employment of Gutenberg at Mentz for some

STYLE 2000.

FONTS OF 14 LB. 10 OZ.

12-POINT SCRIPT, No. 2000.

\$16.95.

Printing did not begin in England until some time after the dispersion of the printers at Mentz in 1462. It was introduced there by William Caxton, a mercer, who had lived in the Low Countries for many years. He began printing in the City of Westminster about the year 1476, having previously issued books on the Continent. His press was very industrious, and produced works steadily up to the time of his death in 1491. Wynken de Worde and Richard Pynson, two of his workmen, each entered into business in the City of London after Caxton's death. Machlinea, who began there in 1510. Other early Notary. In 1540 Theodoric Rodd of Cologne same year an unknown workman, who is generally a printer in the latter town. The art extended to other university town, Cambridge, began printing in

FONTS OF 14 LB.

18-POINT SCRIPT, No. 2000.

\$14.00.

Edinburgh, the capital of Scotland, has now for many years been one of the centres of book-making in the English language. During the reign of James the Fourth one Walter Chepman or Chapman, a rich tradesman and a man of influence, obtained for himself and his associate, Andrew G. Myllar, a patent for printing in Scotland, which is still extant. Myllar had learned the art of printing at Rouen

STYLE 2000.

FONTS OF 14 LB.

14-POINT SCRIPT, No. 2000.

\$15.65.

A Compositor is a gentleman who sets up type; and who also occasionally "sets 'em' up." There are three divisions of workmen in a printing office, excluding the clerks and laborers, who work in one part;

else; with no special knowledge of procedures. Types are compositors; proofmen and readers; the one who gets the form ready for printing, & errors; and the proofman prints it. Some edge of proofreading; which increases their while many are considered excellent judges of bits of strict economy accumulate vast wealth.

FONTS OF 14 LB.

22-POINT SCRIPT, No. 2000.

\$12.60.

Franklin, after setting type a long time in London, conceived the idea that it would be better for him to labor for a while at press, as giving him more exercise; and seventy years ago James Harper and Thurlow Weed wrought at either branch, as occasion might require. Hand-presses

STYLE 2001.

FONTS OF 14 LB. 18-POINT SCRIPT, No. 2001.

\$14.00.

Benjamin Franklin, the chief figure in America before the Revolution, one of the leading characters during it and directly afterwards, and a printer of Philadelphia, was born at Boston, Mass., on January 17, 1706. His father was an Englishman, who emigrated to this country about 1682, and followed the trade of a tallow

FONTS OF 14 LB.

22-POINT SCRIPT, No. 2001.

\$12.60.

Deje's Essay on Projects and one by Mather on Doing Good were among the books which influenced Franklin the most, and to obtain money to purchase more books he induced his brother to allow him a sum

FONTS OF 14 LB.

28-POINT SCRIPT, No. 2001.

\$12.05.

The love for writing which induced Franklin, at the age of 16, to write for his brother's paper, over the "nom de plume" of Silence Dogood, continued a strong passion throughout his

STYLE 2001.

FONTS OF 28 lb.

36-POINT SCRIPT, No. 2001.

\$22.95.

*You are respectfully requested to attend the
next meeting of Our Club and assist in deco-
rating the interior of the
refrigerator with such*

FONTS OF 24 lb. 8 oz.

44-POINT SCRIPT, No. 2001.

\$19.10.

*D^o J. Killebuck,
Maysense and Corn Gradicator,
Epidermaville.*

V. B. MUNSON, SUCCESSOR TO GEO. BRUCE'S SON & CO., 13 CHAMBERS STREET, NEW YORK.

STYLES 2002 AND 2003.

15 a 6 A—18 lb.

36-POINT COPPERPLATE SCRIPT, No. 2002.

\$14.75.

*For Grand Flourish.
In the Matter of
this Script Pills are ill*

STYLES 2002 and 2003
DIFFER ONLY IN THE
CAPITALS and FLOURISHES

30 a 10 A—26 lb.

36-POINT COPPERPLATE SCRIPT, No. 2003.

\$21.30.

*Annual Reception (1900)
Young Men's Bowling Association
of Allegheny, W. Va.*

V. B. MUNSON, SUCCESSOR TO GEO. BRUCE'S SON & CO., 13 CHAMBERS STREET, NEW YORK.

STYLE 2002.

12 a 5 A—28 lb. 8 oz.

48-POINT COPPERPLATE SCRIPT, No. 2002.

\$20.50.

Ancient and Honorable
Sanhaders.
99th Annual Session,
and Pay-day.

STYLE 2003.

15 a G A—26 lb. 10 oz.

48-POINT COPPERPLATE SCRIPT, No. 2003.

\$19.15.

Grand Billinery Opening.

April 1st, 1900.

Latest Imported Styles.

My Feathers.

V. B. MUNSON, SUCCESSOR TO GEO. BRUCE'S SON & CO., 13 CHAMBERS STREET, NEW YORK.

STYLE 2004.

FONTS OF 13 LB. 8 OZ.

12-POINT TITLE SCRIPT, No. 2004.

\$15.65.

The general opinion of all nations is that Germany was the birthplace of printing. The claims of only two places besides Mentz have ever been entertained in this connection by any large number of persons. They are in Haarlem, in Holland, and

several from France. It seems, however, that whatever may have been the case, not printing from movable types,

FONTS OF 14 LB.

18-POINT TITLE SCRIPT, No. 2004.

\$14.00.

Gutenberg's business passed into the hands of relatives by marriage, Henry and Nicholas Bechtermuntz. After them it was in the possession of the Brothers of the Life in Common, who were succeeded by one A. H. N. Jenkyns, from Normandy, who was displeased of certain parts

FONTS OF 14 LB.

22-POINT TITLE SCRIPT, No. 2004.

\$12.60.

As related elsewhere, Gutenberg began his attempts at printing in Strasbourg, removing to Mentz about the year 1444. From the time when the forty-two line Bible was published it is

STYLES 2005 AND 2006.

FONTS OF 13 lb. 10 oz.

18-POINT COPPERPLATE SCRIPT, No. 2005.

\$13.60.

In January, 1833, Horace Greeley began the printing business for himself in conjunction with Francis Story. They printed among other things the first penny daily ever issued. Its editor was Dr. Horatio D. Shepard, who began the enterprise with much faith, but little money, and that was exhausted in less than three weeks. After an existence of six months the partnership o

FONTS OF 14 lb. 14 oz.

22-POINT COPPERPLATE SCRIPT, No. 2006.

\$13.40.

Horace Greeley, who was called by Whittier "our later Franklin," the founder of the New York Tribune, was born of Scotch-Irish descent at Amherst, New Hampshire, on February 3, 1811. He displayed great eagerness in the acquisition of knowledge, and when

STYLE 2007.

FONTS OF 17 lb. 14 oz.

28-POINT ITALIAN SCRIPT, No. 2007.

\$15.35.

Claps of Nineteen Hundred.

*Our Release from Slavery will be celebrated by
a Grand "Coming-out" Ball
and Cake Walk,*

Monday Evening, April 1st, 1900.

You are invited.

STYLES 2008 AND 2009.

FONTS OF 14 lb.

28-POINT NOTARIAL, No. 2008.

\$12.05.

We beg to remind you that your Note for Fifteen Thousand Pounds became due and payable on the 19th instant, but so far we have received no intimation as to your intentions in the matter. The trivial amount represented by the note has

been necessary to enable us to start of interest since 17th non

FONTS OF 14 lb.

22-POINT RUNNING HAND, No. 2009.

\$12.60.

Dear Madam:

New York, January 12, 1900.

Referring to the matter under discussion last evening, I would suggest the advisability of taking a course of about seventeen years in some good School of Education, and you can rest assured that the neighbors will gladly assume

V. B. MUNSON, SUCCESSOR TO GEO. BRUCE'S SON & CO., 13 CHAMBERS STREET, NEW YORK.

STYLE 2011.

FONTS OF 14 lb.

22-POINT ITALIAN SCRIPT, No. 2011.

\$12.60.

*The management take pleasure in announcing to the patrons
of the Bathsheba Roof Garden the engagement for a short shasm,
ding lights in very light opera,*

FONTS OF 14 lb. 10 oz.

44-POINT ITALIAN SCRIPT, No. 2011.

\$11.40.

The Darktown Fire Brigade!

*will celebrate their
Watermelon Bang*

FONTS OF 13 lb.

36-POINT ITALIAN SCRIPT, No. 2011.

\$10.65.

*Yourselves and friends are cordially invited to
call and inspect our latest creations in Spring and
Summer Millinery, the very newest things to be*

V. B. MUNSON, SUCCESSOR TO GEO. BRUCE'S SON & CO., 13 CHAMBERS STREET, NEW YORK.

EXPLANATION OF THE PENMAN SERIES

THE EIGHT SIZES OF PENMAN shown on the following pages are cast so that the descending letters kern below the body and interlock with the ascenders, producing an effect like copperplate. The support to the kerned letters commences much further down the body than in ordinary Scripts, thus preventing the possibility of their breaking off, except by design. The spacing will sometimes have to be altered to accommodate the descending letters, and occasionally flourishes may be used to facilitate the justification. The Caps, Points, Flourishes, Figures, etc., and the first lower case to each size are cast with one nick; the other lower cases are cast with two and three nicks. Printers can thus be cheaply supplied with two or three lower case fonts to the same font of caps, etc., without any danger of commixture in the printing office. As the spaces and metal saved are more than one-third, they are considerably cheaper than ordinary Script.

The following characters constitute a font of Penman Lower Case :

a b c d e f g h i j k l m n o p q r s t u v w x y z 0 1 2 3 4 5 6 7 8 9 10 11 12 13 14 15 16 17 18 19 20 21 22 23 24 25 26 27 28 29 30 31 32 33 34 35 36 37 38 39 40 41 42 43 44 45 46 47 48 49 50 51 52 53 54 55 56 57 58 59 60 61 62 63 64 65 66 67 68 69 70 71 72 73 74 75 76 77 78 79 80 81 82 83 84 85 86 87 88 89 90 91 92 93 94 95 96 97 98 99 100 101 102 103 104 105 106 107 108 109 110 111 112 113 114 115 116 117 118 119 120 121 122 123 124 125 126 127 128 129 130 131 132 133 134 135 136 137 138 139 140 141 142 143 144 145 146 147 148 149 150 151 152 153 154 155 156 157 158 159 160 161 162 163 164 165 166 167 168 169 170 171 172 173 174 175 176 177 178 179 180 181 182 183 184 185 186 187 188 189 190 191 192 193 194 195 196 197 198 199 200 201 202 203 204 205 206 207 208 209 210 211 212 213 214 215 216 217 218 219 220 221 222 223 224 225 226 227 228 229 230 231 232 233 234 235 236 237 238 239 240 241 242 243 244 245 246 247 248 249 250 251 252 253 254 255 256 257 258 259 260 261 262 263 264 265 266 267 268 269 270 271 272 273 274 275 276 277 278 279 280 281 282 283 284 285 286 287 288 289 290 291 292 293 294 295 296 297 298 299 300 301 302 303 304 305 306 307 308 309 310 311 312 313 314 315 316 317 318 319 320 321 322 323 324 325 326 327 328 329 330 331 332 333 334 335 336 337 338 339 340 341 342 343 344 345 346 347 348 349 350 351 352 353 354 355 356 357 358 359 360 361 362 363 364 365 366 367 368 369 370 371 372 373 374 375 376 377 378 379 380 381 382 383 384 385 386 387 388 389 390 391 392 393 394 395 396 397 398 399 400 401 402 403 404 405 406 407 408 409 410 411 412 413 414 415 416 417 418 419 420 421 422 423 424 425 426 427 428 429 430 431 432 433 434 435 436 437 438 439 440 441 442 443 444 445 446 447 448 449 450 451 452 453 454 455 456 457 458 459 460 461 462 463 464 465 466 467 468 469 470 471 472 473 474 475 476 477 478 479 480 481 482 483 484 485 486 487 488 489 490 491 492 493 494 495 496 497 498 499 500 501 502 503 504 505 506 507 508 509 510 511 512 513 514 515 516 517 518 519 520 521 522 523 524 525 526 527 528 529 530 531 532 533 534 535 536 537 538 539 540 541 542 543 544 545 546 547 548 549 550 551 552 553 554 555 556 557 558 559 560 561 562 563 564 565 566 567 568 569 570 571 572 573 574 575 576 577 578 579 580 581 582 583 584 585 586 587 588 589 590 591 592 593 594 595 596 597 598 599 600 601 602 603 604 605 606 607 608 609 610 611 612 613 614 615 616 617 618 619 620 621 622 623 624 625 626 627 628 629 630 631 632 633 634 635 636 637 638 639 640 641 642 643 644 645 646 647 648 649 650 651 652 653 654 655 656 657 658 659 660 661 662 663 664 665 666 667 668 669 670 671 672 673 674 675 676 677 678 679 680 681 682 683 684 685 686 687 688 689 690 691 692 693 694 695 696 697 698 699 700 701 702 703 704 705 706 707 708 709 710 711 712 713 714 715 716 717 718 719 720 721 722 723 724 725 726 727 728 729 730 731 732 733 734 735 736 737 738 739 740 741 742 743 744 745 746 747 748 749 750 751 752 753 754 755 756 757 758 759 760 761 762 763 764 765 766 767 768 769 770 771 772 773 774 775 776 777 778 779 780 781 782 783 784 785 786 787 788 789 790 791 792 793 794 795 796 797 798 799 800 801 802 803 804 805 806 807 808 809 810 811 812 813 814 815 816 817 818 819 820 821 822 823 824 825 826 827 828 829 830 831 832 833 834 835 836 837 838 839 840 841 842 843 844 845 846 847 848 849 850 851 852 853 854 855 856 857 858 859 860 861 862 863 864 865 866 867 868 869 870 871 872 873 874 875 876 877 878 879 880 881 882 883 884 885 886 887 888 889 890 891 892 893 894 895 896 897 898 899 900 901 902 903 904 905 906 907 908 909 910 911 912 913 914 915 916 917 918 919 920 921 922 923 924 925 926 927 928 929 930 931 932 933 934 935 936 937 938 939 940 941 942 943 944 945 946 947 948 949 950 951 952 953 954 955 956 957 958 959 960 961 962 963 964 965 966 967 968 969 970 971 972 973 974 975 976 977 978 979 980 981 982 983 984 985 986 987 988 989 990 991 992 993 994 995 996 997 998 999 1000

and the following a font of Caps, Points, Flourishes, Figures, etc.:

*A B C D E F G H I J K L M N O P Q R
S T U V W X Y Z 0 1 2 3 4 5 6 7 8 9 1 1 2 1 1 2 1 1*

also Spaces and Quads.

In the 60-Point and 84-Point the characters *W* and *V* are omitted, and *o* substituted.

The
PERMAN

*Comprising eight sizes, ranging
from 12 to 84 Point, the Perma Series
forms the*

Series.

**Standard,
Most Serviceable,
and Cheapest**

*A printing establishment equipped with
this series needs no other script*

*Series of Scripts ever produced in this
or any other country*

STYLES 2051 AND 2053.

60 n 15 A—8 lb. 12 oz.

12-POINT PENMAN, No. 2051.

\$10.15.

I resume the history of our own city (Haarlem), to which, I assert, the chief honor of the invention of the Art of Printing is justly due; and which, I maintain, may be asserted with the greatest justice as of its own and native right. There is, however, an ancient opinion which alone eclipses our splendor, which is inscribed in the minds of some as if it had been burnt in by fire; so deeply rooted that no mattock, no wedge, no picture is able to eradicate or destroy it. In conformity with this opinion have the forms of letters with which we converse at Mentz, a celebrated and ancient Oh that I could obtain by a wish that

THESE TWO STYLES OF LOWER CASE
REQUIRE ONLY ONE FONT OF CAPS

60 n 15 A—8 lb. 10 oz.

12-POINT PENMAN, No. 2053.

\$10.00.

These dwell in Haarlem, about one hundred and twenty-eight years ago, in a public edifice of some magnificence (as the fabric which still remains can attest), overlooking the market place, opposite the Royal Palace, a man named Laurentius Johannes, surnamed Custos, because his family, by hereditary right, possessed an honorable and lucrative office distinguished by that title. To this man the world is indebted for an art more truly worthy of the laurel than that which binds the brow, for by the clearest right, and by the most solemn assertions, he is entitled to the credit

V. B. MUNSON, SUCCESSOR TO GEO. BRUCE'S SON & CO., 13 CHAMBERS STREET, NEW YORK.

STYLES 2051 AND 2053.

50 & 12 A—11 lb. 8 oz.

16-POINT PENMAN, No. 2051.

\$12.20.

*Walking in a wood near the City (as was the custom of
Opulent Citizens on festivals, or after dinner), he began to cut
Letters on the bark of a Beech Tree, which he, for the sake of
amusement, pressed on paper, in an inverted order, for his grand-
children to imitate. Having succeeded in this, and being a man*

50 & 12 A—11 lb. 10 oz.

16-POINT PENMAN, No. 2053.

\$12.30.

*Of talent and ingenuity, he began to meditate, on greater
things, and being assisted by his son-in-law, Peter Thomas (who
had four sons, who almost all attained consular dignity, which I
mention to show that the City owes its origin to a family of dis-
tinguished rank and position), he invented a more glutinous and*

ONLY ONE FONT OF CAPS
IS REQUIRED FOR BOTH
THESE STYLES OF
LOWER CASE

V. B. MUNSON, SUCCESSOR TO GEO. BRUCE'S SON & CO., 13 CHAMBERS STREET, NEW YORK.

STYLES 2051, 2052 AND 2053.

40 a 10 A
14 lb. 4 oz. 20-POINT PENMAN, No. 2051. \$13.40.

In 1815 a gentleman named Didot contrived a Script or leaning body, so as to make the joints more perfect and give better shape to letters. This form gradually

40 a 10 A
13 lb. 2 oz. 20-POINT PENMAN, No. 2052. \$12.35.

The great difficulty in cutting Script has been to make the lines of one letter join those of the next; and while these lines are always light, the task is filled with difficulty. And it

40 a 10 A—14 lb. 20-POINT PENMAN, No. 2053. \$13.15.

*Corresponding Secretary's Office,
Association for the Advancement of Wages
Soldier's Alley*

THESE THREE
STYLES OF
LOWER CASE
REQUIRE ONLY
ONE FONT OF
CAPS

V. B. MUNSON, SUCCESSOR TO GEO. BRUCE'S SON & CO., 13 CHAMBERS STREET, NEW YORK.

STYLES 2051, 2052 AND 2053.

<p>30 & 7 A—16 lb. 6 oz.</p> <p>At a representative meeting of the largest dealers in Artesian Wells in the west, it was and immediately feared</p>	<p>24-POINT PENMAN, No. 2051. \$14.75.</p>
<p>30 & 7 A—15 lb. 12 oz.</p> <p>In accordance with a custom, very generally observed by the Retail trade of America, Whizzing & Co. take pleasure</p>	<p>24-POINT PENMAN, No. 2053. \$14.15.</p>
<p>with regard to we it altered</p> <p>He might</p>	<p>24-POINT PENMAN, No. 2052. \$13.60.</p> <p>also notice that there is considerable difference in size between this face and 2051 at the top of this page.</p>

THESE THREE STYLES OF LOWER CASE REQUIRE ONLY ONE FONT OF CAPS

V. B. MUNSON, SUCCESSOR TO GEO. BRUCE'S SON & CO., 13 CHAMBERS STREET, NEW YORK.

STYLE 2051.

20 a 6 A—19 lb. 14 oz.

32-POINT PENMAN, No. 2051.

\$16.30.

*Masterpieces in Oil
The World's Greatest Painters!*

*On view to-day,
Saturday, December 30th.*

THIS LOWER CASE AND THOSE ON PAGES 345 AND 346
REQUIRE ONLY ONE FONT OF CAPS

V. B. MUNSON, SUCCESSOR TO GEO. BRUCE'S SON & CO., 13 CHAMBERS STREET, NEW YORK.

STYLE 2052.

20 & 6 A—18 lb. 8 oz.

32-POINT PENMAN, No. 2052.

\$15.15.

Commencement Exercises.
Miss Foster's School of Oratory
for Young Ladies,
Monday Evening; April 1st.

THIS LOWER CASE AND THOSE ON PAGES 344 AND 346
REQUIRE ONLY ONE FONT OF CAPS

V. B. MUNSON, SUCCESSOR TO GEO. BRUCE'S SON & CO., 13 CHAMBERS STREET, NEW YORK.

STYLE 2053.

20 a 6 A—19 lb.

32-POINT PENMAN, No. 2053.

\$15.60.

Bruce's New York Type Foundry.

A King Among Scripts,

The Penman Series.

W. B. Munson.

THIS LOWER CASE AND THOSE ON PAGES 344 AND 345
REQUIRE ONLY ONE FONT OF CAPS

V. B. MUNSON, SUCCESSOR TO GEO. BRUCE'S SON & CO., 13 CHAMBERS STREET, NEW YORK.

STYLE 2053.

12 & 6 A—23 lb. 4 oz.

44-POINT PENMAN, No. 2053.

\$18.15.

*Good Resolutions for 1900,
Made Dec. 31, 1899,
and, owing to the extreme cold,
Dusted January 2, 1900.*

THIS LOWER CASE AND THAT SHOWN ON PAGE 348
REQUIRE ONLY ONE FONT OF CAPS

V. B. MUNSON, SUCCESSOR TO GEO. BRUCE'S SON & CO., 13 CHAMBERS STREET, NEW YORK.

STYLE 2054.

12 a 6 A—23 lb. 10 oz.

44-POINT PENMAN, No. 2054.

\$18.45.

National Anglers' Association.
Annual Outing
Prizes for Editorial Poems.
Fishy Yams.

THIS LOWER CASE AND THAT SHOWN ON PAGE 347
REQUIRE ONLY ONE FONT OF CAPS

V. B. MUNSON, SUCCESSOR TO GEO. BRUCE'S SON & CO., 13 CHAMBERS STREET, NEW YORK.

STYLE 2053.

8 8 3 A—24 lb. 12 oz.

60-POINT PENMAN, No. 2053.

• \$15.85.

*Notwithstanding
Friendly Interference
it is successful.*

THIS LOWER CASE AND THAT SHOWN ON PAGE 350
REQUIRE ONLY ONE FONT OF CAPS

V. B. MUNSON, SUCCESSOR TO GEO. BRUCE'S SON & CO., 13 CHAMBERS STREET, NEW YORK.

STYLE 2054.

8 & 3 A—23 lb. 12 oz.

60-POINT PENMAN, No. 2054.

\$15.20.

*D. D. Wick Express Co.
Forwarding.
Only Automobiles.*

THIS LOWER CASE AND THAT SHOWN ON PAGE 349
REQUIRE ONLY ONE FONT OF CAPS

V. B. MUNSON, SUCCESSOR TO GEO. BRUCE'S SON & CO., 13 CHAMBERS STREET, NEW YORK.

STYLE 2053.

8 a 3 A—44 lb. 8 oz.

84-POINT PENMAN, No. 2053.

\$26.70.

Medals. George & Co.

THIS LOWER CASE AND THAT ON PAGE 352
REQUIRE ONLY ONE FONT OF CAPS

V. B. MUNSON, SUCCESSOR TO GEO. BRUCE'S SON & CO., 13 CHAMBERS STREET, NEW YORK.

STYLE 2054.

8 a 3 A—42 lb. 8 oz.

84-POINT PENMAN, No. 2054.

\$25.50.

*Shawto Company,
Cap. \$17.50.*

THIS LOWER CASE AND THAT ON PAGE 351
REQUIRE ONLY ONE FONT OF CAPS

V. B. MUNSON, SUCCESSOR TO GEO. BRUCE'S SON & CO., 13 CHAMBERS STREET, NEW YORK.

“POST” OLD STYLE ROMAN No 1

72 POINT

3A 4a \$19 00

FUNDS
Receive
Cash 14

60 POINT

3A 4a \$11 50

RENDER
Old Song
of Home 7

54 POINT °

3 A 4 a \$10 75

PRINTED
Record of
all Building
Societies 3

48 POINT °

3 A 4 a \$8 50

REGIMENT
The Modern
Methods &
Ideas of 34

“POST” OLD STYLE ROMAN No 1

42 POINT

3 A 4 a \$7 00

CHERISHED
Memories of 4

36 POINT

5 a \$5 50

AGED SAILOR
Haven of Rest by
the Seaside ♣ 92

30 POINT

4 A 6 a \$4 25

DISTINCT STYLES
Publisher Requested
all Advertisers ♡ 38

24 POINT

6 A 9 a \$3 75

FORCED MARCHING
The Advance Guard of
Napoleon's Army at ♣ 2

18 POINT

8 A 12 a \$3 25

CHEAPNESS EXEMPLIFIED
Our Fifth Annual Sale of Fine White Lawn Goods begins this morning. People who watch for real cheapness in honest \$985

12 POINT

14 A 20 a \$2 75

DOMESTIC GOODS
Last week we told you the new Woolens and Worsteds for the closing sartorial season of the 19th Century ♣ 5

8 POINT

16 A 24 a \$2 25

COUNTRY LOTS FOR SALE
The people are learning that prices on all kinds of real estate are much lower here than at any other leading houses in our line of business. There is nothing uncertain about this. It is done in pursuance ♣ 398

6 POINT

16 A 25 a \$2 00

HIGH GRADE PIANO SELLING
We have inaugurated a Special Piano Sale for the month of September to dispose of a large stock of very slightly used Pianos. The sale is necessitated through the extensive alterations which are to be made in our warerooms. All the Pianos are marked from one-third to one-half below our \$348

10 POINT

14 A 20 a \$2 50

SLUMP IN COTTON
The current week starts with less than a week's supply of cotton in the Liverpool market and a five days' supply on the sea. Cotton has been 2

14 POINT

12 A 18 a \$3 00

SPRING SALE OF DRESS FABRICS
Judging by the great variety of weaves that are now on exhibition in the Black Dress Goods Department, it would be difficult to name a special leader. From present indications it seems that \$247

“POST” OLD STYLE ROMAN No 2

72 POINT

3 A 4 a \$20 00

HEIRS
Claims
Made 8

60 POINT

3 A 4 a \$13 00

DESIGN
Work of
Merit  3

54 POINT

3 A 4 a \$11 25

MONTHS
Notice of
Dividend
Served 4

48 POINT °

3 A 4 a \$9 50

RETIRING
The Senior
Member of
the Firm 9

“POST” OLD STYLE ROMAN No 2

42 POINT

3A 4a \$7 50

BURDENED
Mankind ♣ 8

36 POINT

3A 5a \$5 75

AMUSEMENT
Entertained by
Bright People 7

30 POINT

4A 6a \$4 50

BRIGHT SCENES
Humorous Sketch
Acted by the ♠ 25

24 POINT

5A 8a \$3 50

SURPRISED NATIVE
The Introduction of a
Steamboat Line ♣ \$42

"POST" OLD STYLE ROMAN No 2

18 POINT

7 A 10 a \$3 25

SOUND SWEET MELODIES
Music is the source of our social pleasures; it soothes violent impulses in man, it dignifies ceremony ♪ ♪ 39

12 POINT

12 A 18 a \$2 75

AUTUMN STYLES
To-day you are invited to inspect the greatest display of Silks & Satins ever seen in this city ♪ 8

8 POINT

14 A 20 a \$2 25

STUDY IN ASTRONOMY
The principal thing in a telescope is the object-glass. It brings the rays of light to a focus, and these create an image of the object looked at. The image is in turn ♪ 2346

6 POINT

15 A 24 a \$2 00

OF INTEREST TO WOMEN
This lot of Dress Goods includes every worthy weave that has come from the mills of two continents during the past twelve-month. Many of the fabrics are enriched by scarf lines of threads, and by other means of ornamentation which reflect the ♪ 39

10 POINT

12 A 18 a \$2 50

SHADES & COLOR
The Satins and Silks that we now have in stock baffle description. The flashes of color in them know no rule but the ♪ 45

14 POINT

10 A 15 a \$3 00

EDUCATION AND ENJOYMENT
Milton was not only the grandest poet who has lived since Homer, but he was one of the most able schoolmasters of the period, and devised for all his pupils a ♪ 235

“POST” OLD STYLE ITALIC

60 POINT

3 A 4 a \$10 50

PROSPER
Gold Mine
Bought \$15

48 POINT

3 A 5 a \$7 25

ENCOURAGE
Resolute Youth
Determined to
Succeed in 68

“POST” OLD STYLE ITALIC

36 POINT

3 A 6 a 84 75

WORKS OF ART
The most attractive
place in this House
is our immense Art
Department. Work
of all the Master 12

30 POINT

4 A 9 a 84 25

SHIRTS & COLLARS
We celebrate a sale in
Suspenders to-day that
will appeal to men of
good taste who do not
object to saving \$2793

“POST” OLD STYLE ITALIC

24 POINT

5 A 12 a \$3 75

***SALE OF TABLE LINEN
AND MUSLINS TO-DAY***

*Buying all our Linen at the
lowest possible figures, we
can sell at bottom prices 87*

18 POINT

7 A 16 a \$3 00

***A MOST COMPLETE LINE OF
FALL SHOES FOR LADIES \$25***

*The newest and prettiest styles for
women are ready to-day, and every
day we are receiving large lots of
the most desirable shapes from our
factory. Call and see our stock 54*

14 POINT

9 A 20 a \$2 75

***A LARGE SALE OF CLOTHS, ETC.
FOR THE AUTUMN AND WINTER***

*Will be opened at 10 o'clock this morn-
ing, and continue throughout the week.
Our salesmen have been through all the
large European cities to secure this stock
of fine Clothing which we claim cannot
be equaled anywhere in this city \$23567*

"POST" OLD STYLE ITALIC

12 POINT

10 A 25 a \$2 50

HOUR SALES COMMENCE AT NINE O'CLOCK EVERY THURSDAY AND FRIDAY MORNING

Keeping in touch with the enterprise which is now attracting much attention in the city, we announce that we will have "Hour Sales" every Thursday and Friday all day. The prices we quote are such as will challenge immediate attention; but \$12456

10 POINT

14 A 32 a \$2 50

THIS IS THE HEADQUARTERS FOR FUR GOODS OF ALL DESCRIPTIONS SELLING AT LOWEST PRICES

Gifts of fur will be acceptable this holiday season, in spite of what the thermometer may say: for Furs are so very popular just now that the up-to-date maid or matron will wear them on proper occasions, whether the weather demands their use or not. These stores are headquarters for good Furs. Prices are the lowest for garments \$8239

8 POINT

14 A 32 a \$2 25

FIRST DISPLAY TO-DAY OF THIS HANDSOME COLLECTION OF LARGE ORIENTAL RUGS SECURED AT CONSTANTINOPLE

After a very extensive tour through the countries of the Orient, our salesmen have brought back such a collection of some of the rarest kinds of rugs as are not to be seen in any of the other stores in this city. For years we have been in the Oriental Rug business in about the same way as a great many other stores in this country, except that our prices were fair and uniform and not "artistic." The Rugs were conventional and of as good a quality as we had a right \$984

6 POINT

16 A 36 a \$2 00

PERFECTING A CAMERA WHICH PEERS THROUGH THE DENSEST MIST. IT WILL BE FOUND OF PRACTICAL VALUE TO NAVIES OF THE WORLD

In setting this camera for an exposure against fogs, a color screen is used. This is necessary because of the fact that the ordinary fog radiates an excess of blue actinic rays that fog a plate easily. With the seven lenses and the screen, however, the colors of the spectroscope are so blended, neutralized and centered as to make an impression through a dense fog that is more clear cut than a sunlight exposure made through an achromatic lens. From the bow of a boat moving at half speed through fog this apparatus will show every outline of a vessel half a mile away. It is discovered already that this apparatus has a remarkable 712

"POST" ORNAMENTS

Order by Name and No.

No. 152. 60 cts.



No. 154. 60 cts.



No. 151. 60 cts.



No. 156. 60 cts.



No. 153. 60 cts.



No. 155. 60 cts.



No. 194. 40 cts.



No. 192. 40 cts.



No. 193. 40 cts.



No. 197. 40 cts.



No. 195. 40 cts.



No. 196. 40 cts.



No. 189. 40 cts.



No. 186. 40 cts.



No. 184. 40 cts.



No. 187. 40 cts.



No. 190. 40 cts.



No. 188. 40 cts.



No. 183. 40 cts.



BRUCE TYPE FOUNDRY, 13 CHAMBERS STREET, NEW YORK.

"POST" ORNAMENTS

Order by Name and No.

No. 172. 50 cts.



No. 171. 50 cts.



No. 169. 50 cts.



No. 170. 50 cts.



No. 168. 50 cts.



No. 179. 50 cts.



No. 180. 50 cts.



No. 177. 50 cts.



No. 182. 50 cts.



No. 176. 50 cts.



No. 175. 50 cts.



No. 159. 60 cts.



No. 166. 60 cts.



No. 164. 60 cts.



No. 160. 60 cts.



No. 161. 60 cts.



No. 158. 60 cts.



No. 162. 60 cts.



No. 163. 60 cts.



BRUCE TYPE FOUNDRY, 13 CHAMBERS STREET, NEW YORK.

MORTISED INITIAL ORNAMENTS

*Order by Name
and No.*



No. 11. 80 cts.



No. 9. 80 cts.



No. 8. 80 cts.



No. 2. 80 cts.



No. 5. 80 cts.



No. 15. 80 cts.

BRUCE TYPE FOUNDRY, 13 CHAMBERS STREET, NEW YORK.

MORTISED INITIAL ORNAMENTS

*Order by Name
and No.*



No. 36. 70 cts.



No. 34. 70 cts.



No. 56. 60 cts.



No. 48. 60 cts.



No. 49. 60 cts.



No. 25. 70 cts.



No. 32. 70 cts.



No. 45. 60 cts.



No. 54. 60 cts.



No. 44. 60 cts.



No. 46. 60 cts.



No. 47. 60 cts.



No. 43. 60 cts.



No. 23. 70 cts.



No. 35. 70 cts.



No. 50. 60 cts.



No. 53. 60 cts.



No. 55. 60 cts.

BRUCE TYPE FOUNDRY, 13 CHAMBERS STREET, NEW YORK.

POINTERS--6 AND 12-POINT

NO. 1

PER FONT, \$1.30.

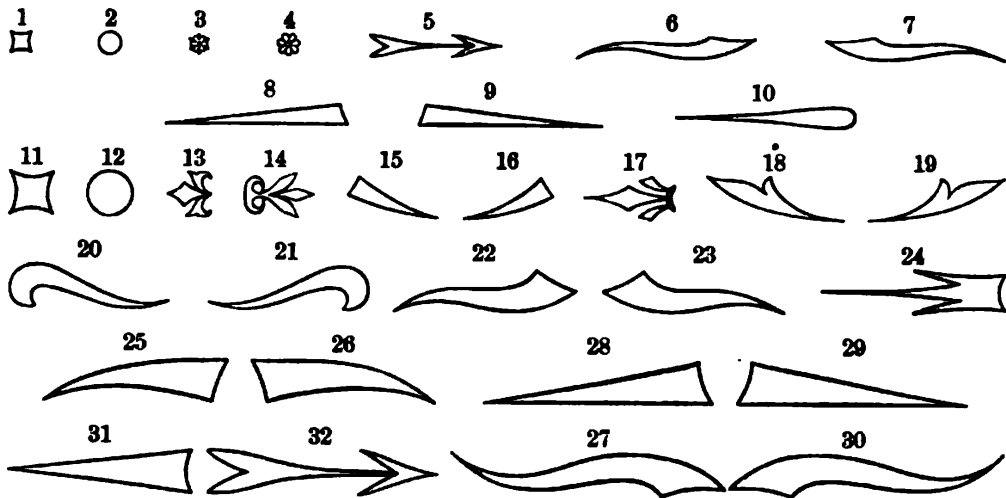

NO. 2

PER FONT, \$1.90.

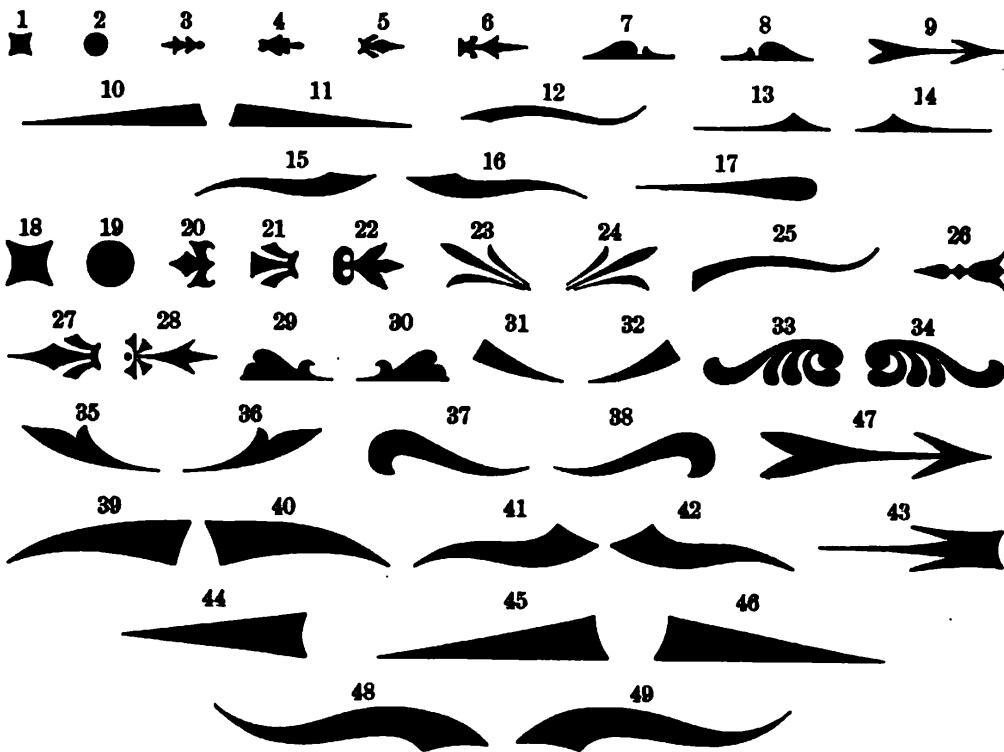

WORD ORNAMENTS

TWELVE POINT



PER LB. 66 CENTS.

V. B. MUNSON, SUCCESSOR TO
GEO. BRUCE'S SON & CO., 13 CHAMBERS STREET, NEW YORK.

SIX POINT BORDERS.

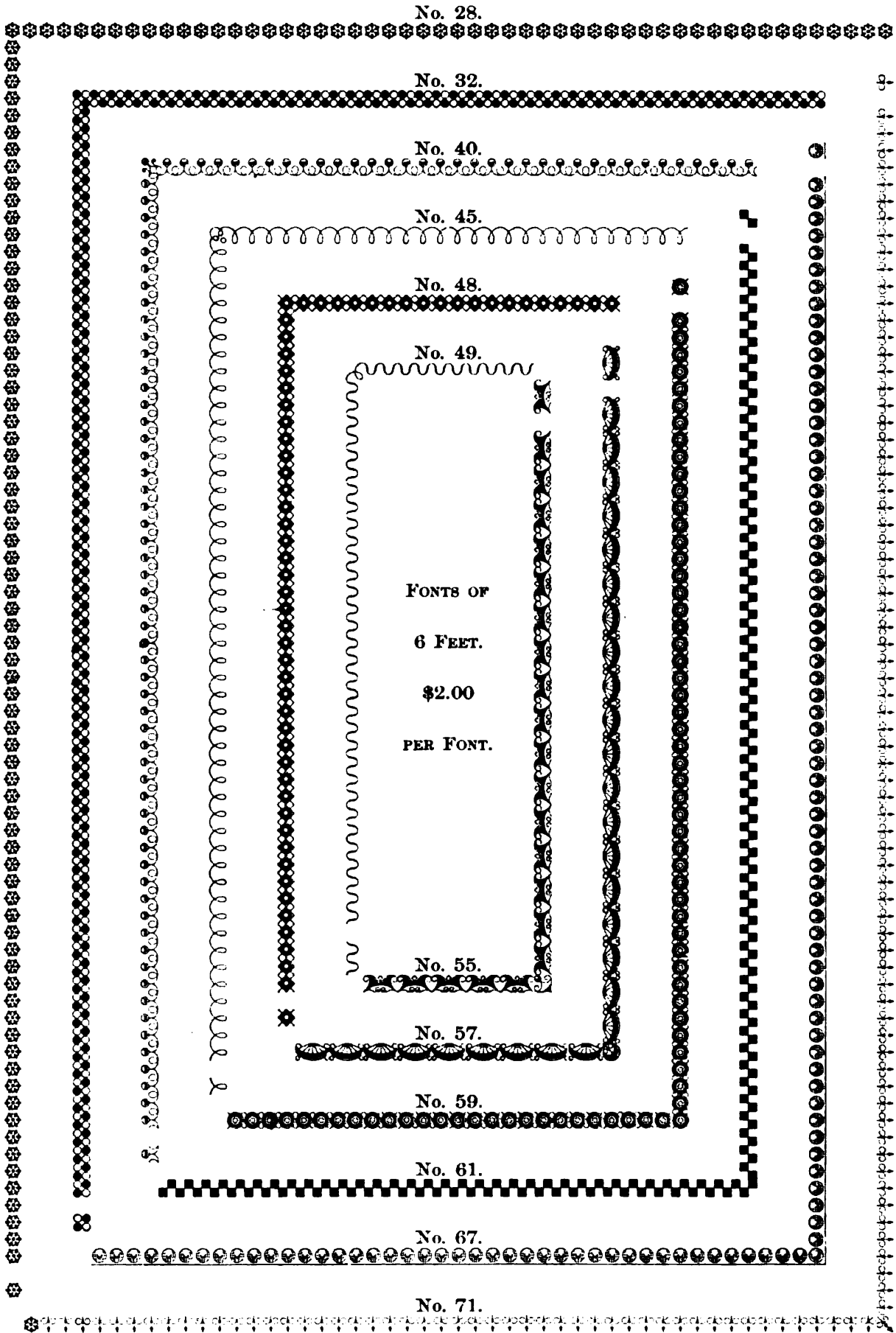

V. B. MUNSON, SUCCESSOR TO
GEO. BRUCE'S SON & CO., 13 CHAMBERS STREET, NEW YORK.

SIX POINT BORDERS

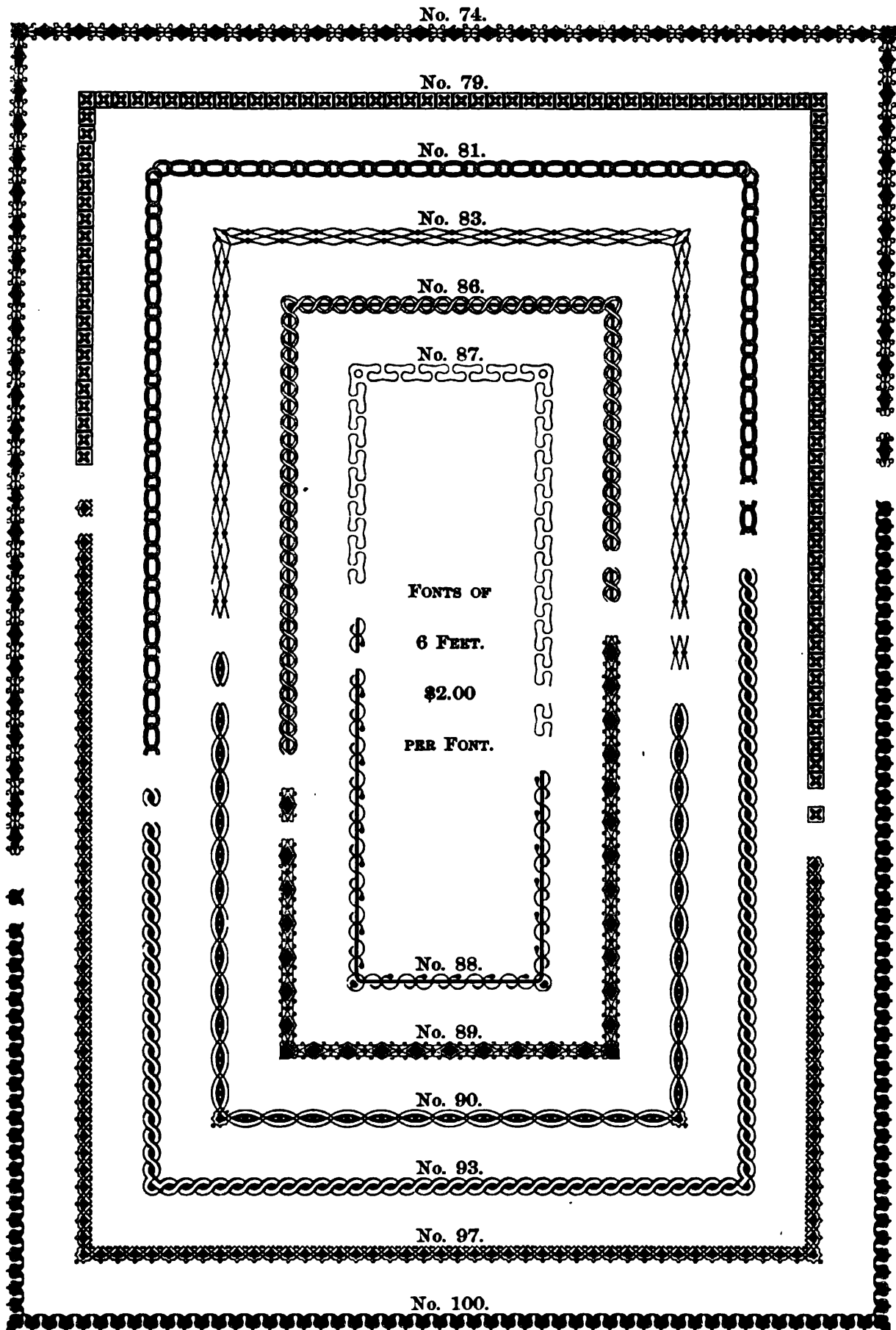

V. B. MUNSON, SUCCESSOR TO
GEO. BRUCE'S SON & CO., 13 CHAMBERS STREET, NEW YORK.

SIX POINT BORDERS

IN FONTS OF 6 FEET—\$2.00 PER FONT.

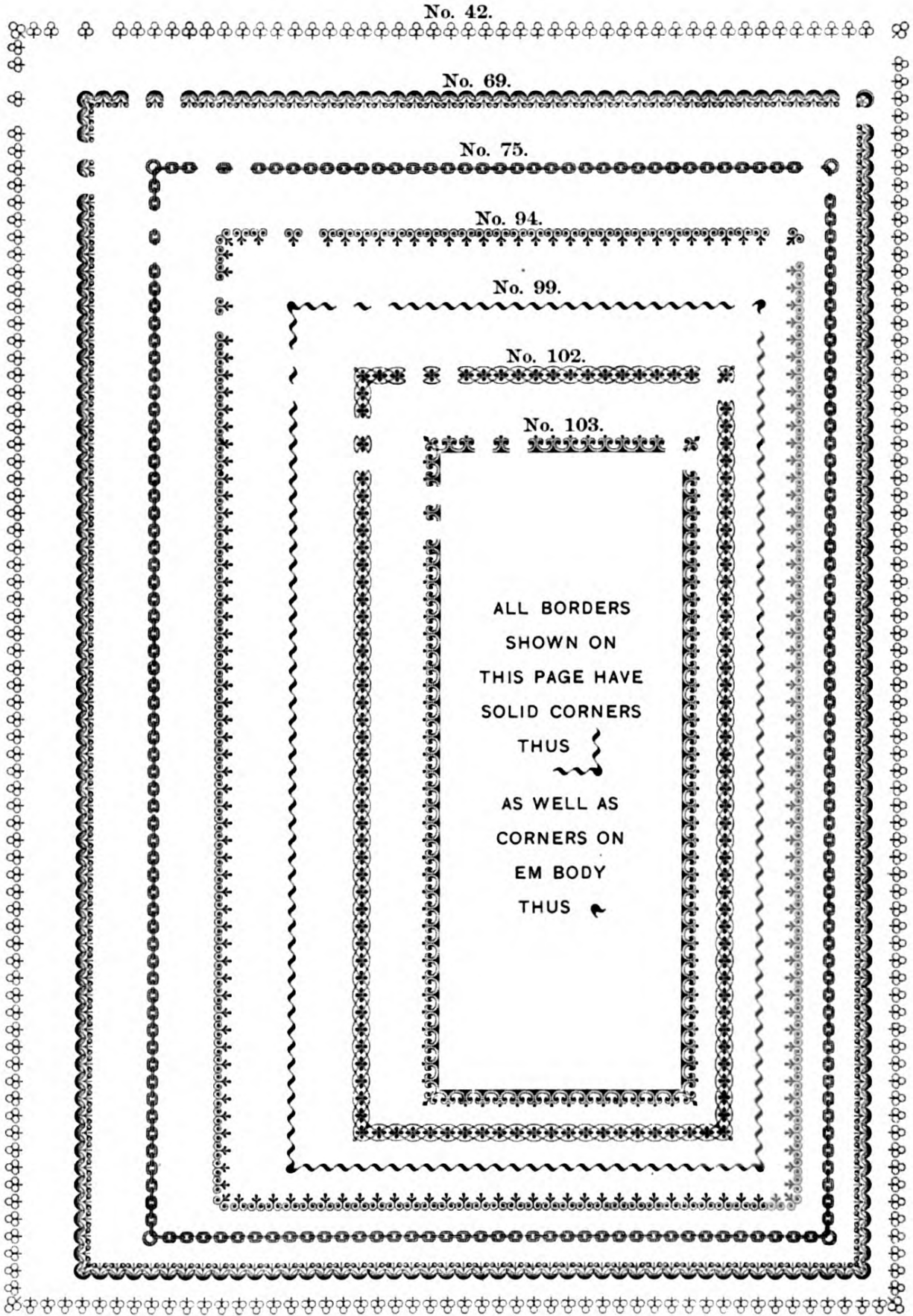

V. B. MUNSON, SUCCESSOR TO
GEO. BRUCE'S SON & CO., 13 CHAMBERS STREET, NEW YORK.

SIX POINT BORDERS

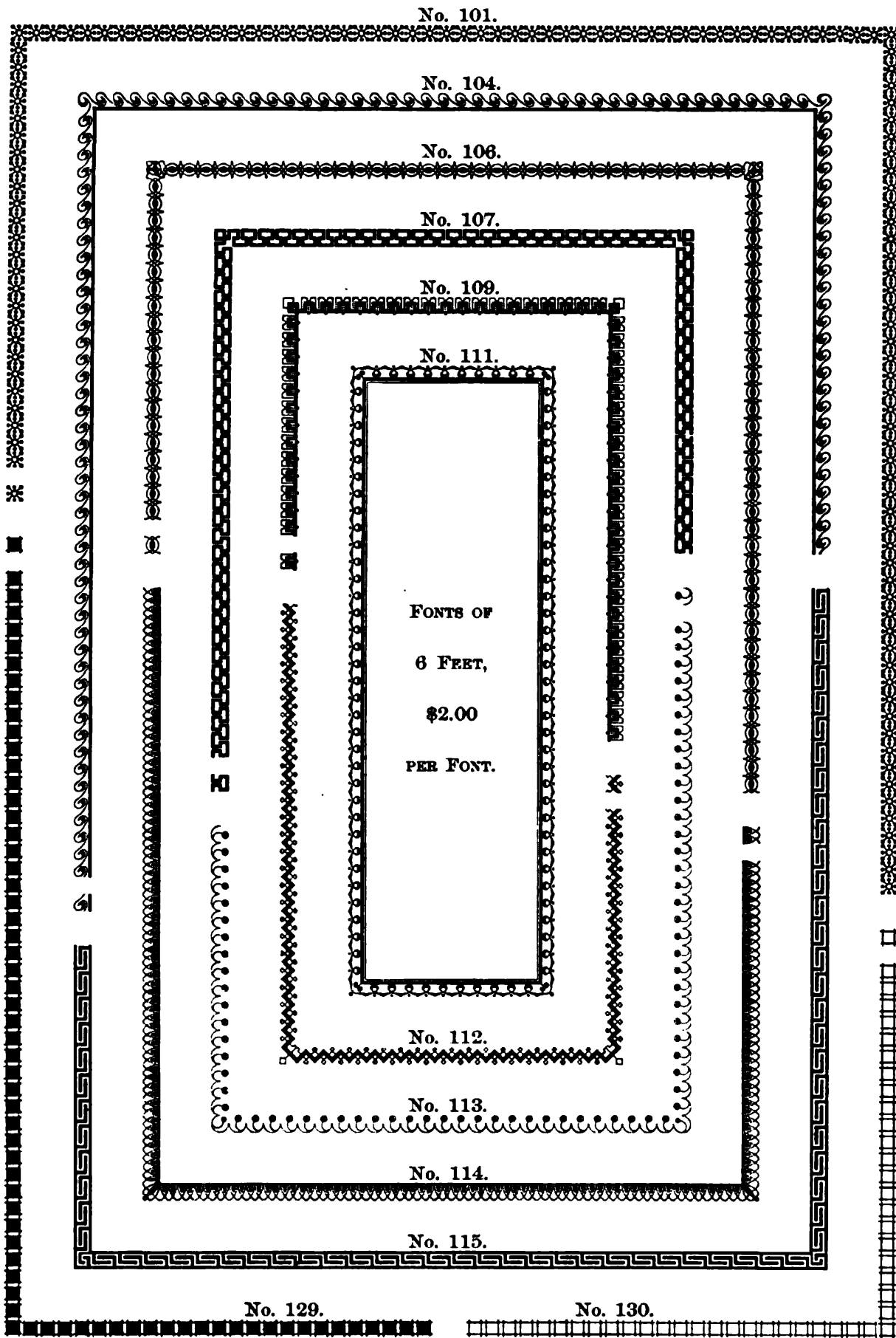

V. B. MUNSON, SUCCESSOR TO
GEO. BRUCE'S SON & CO., 13 CHAMBERS STREET, NEW YORK.

NINE POINT BORDERS

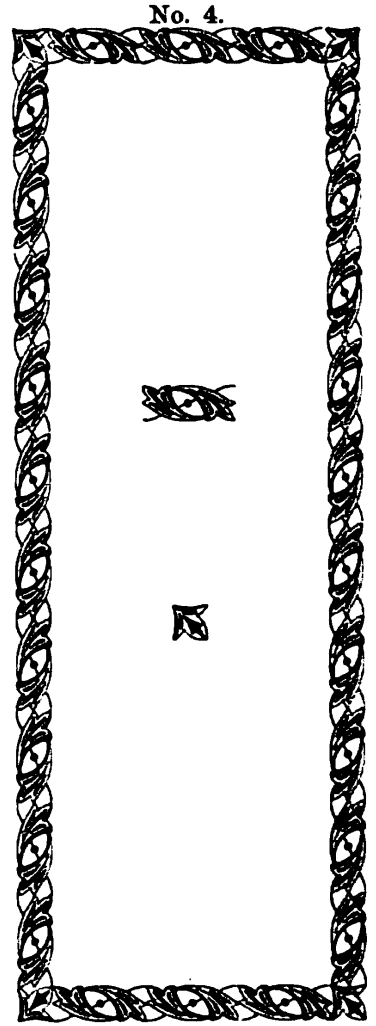
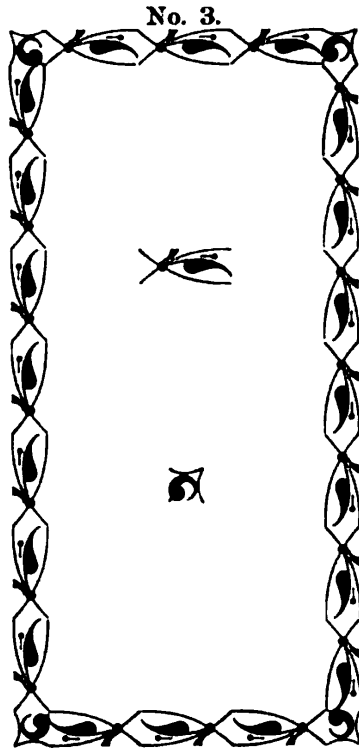
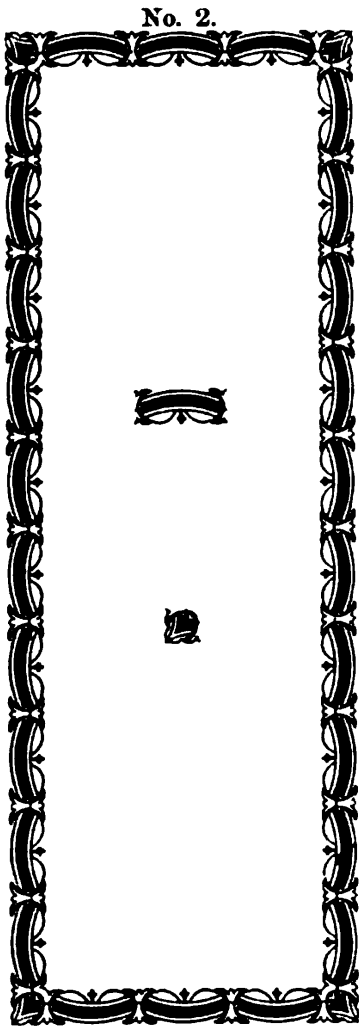

FONTS OF 6 FEET.
\$2.00 PER FONT.

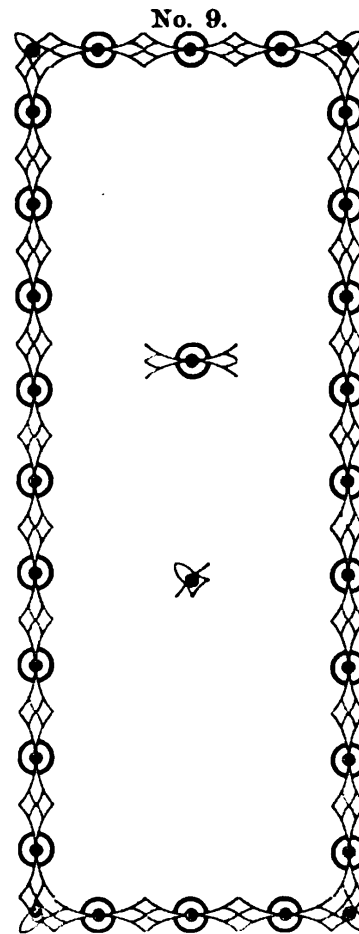
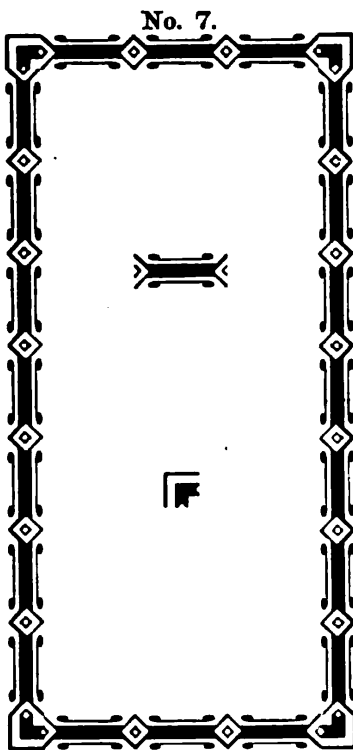

V. B. MUNSON, SUCCESSOR TO
GEO. BRUCE'S SON & CO., 13 CHAMBERS STREET, NEW YORK.

NINE POINT BORDERS

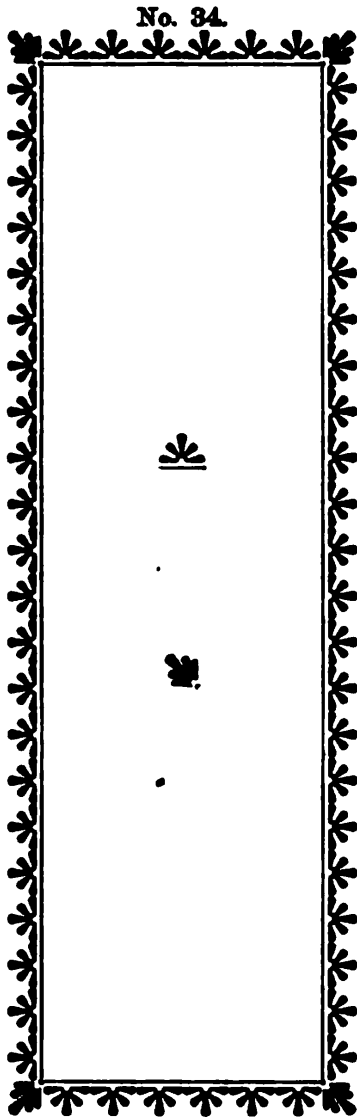
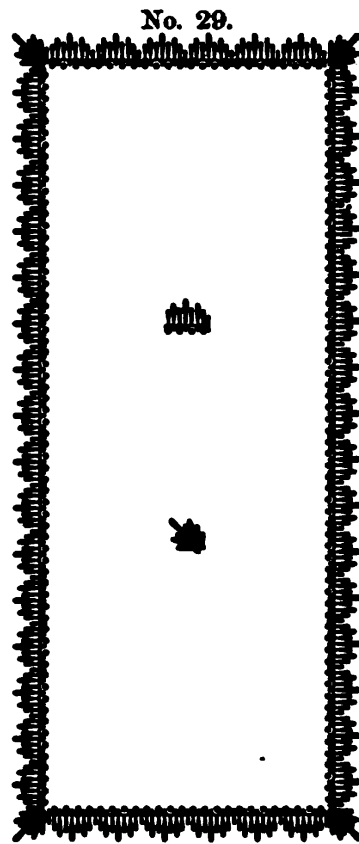
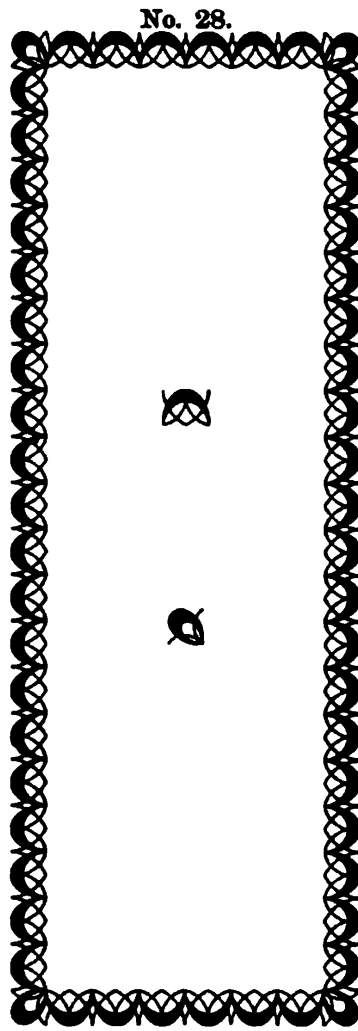
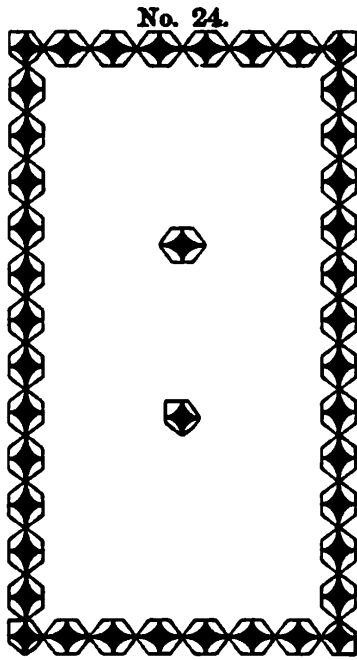

FONTS OF 6 FEET.
\$2.00 PER FONT.

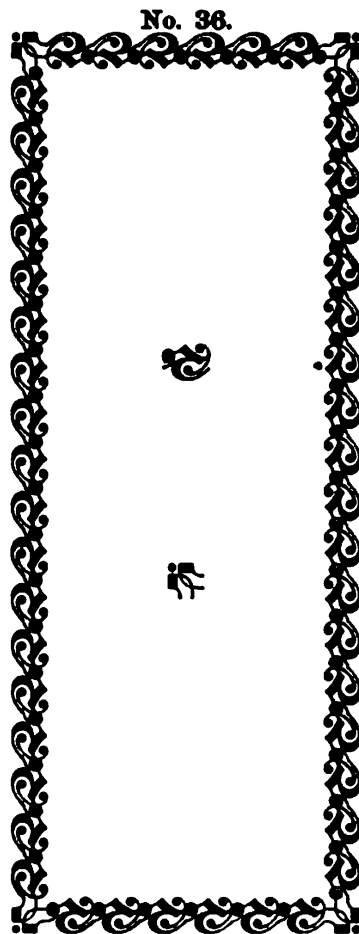

V. B. MUNSON, SUCCESSOR TO
GEO. BRUCE'S SON & CO., 13 CHAMBERS STREET, NEW YORK.

NINE POINT BORDERS

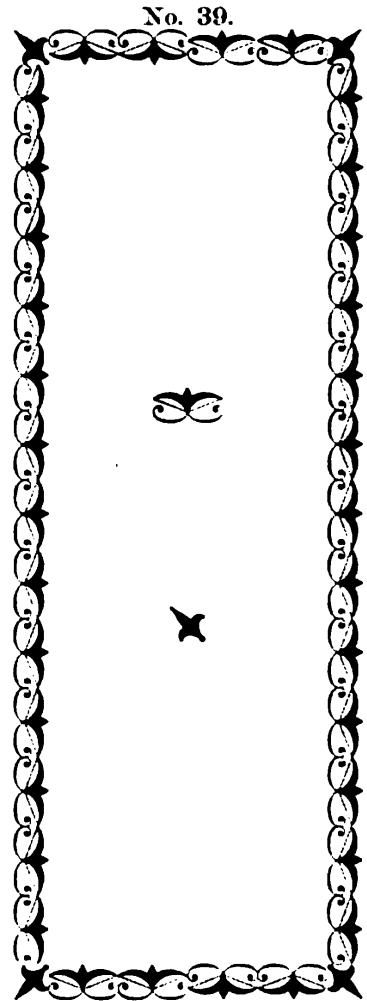
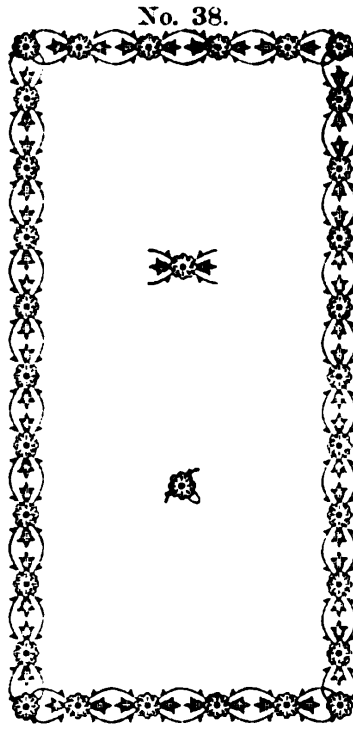
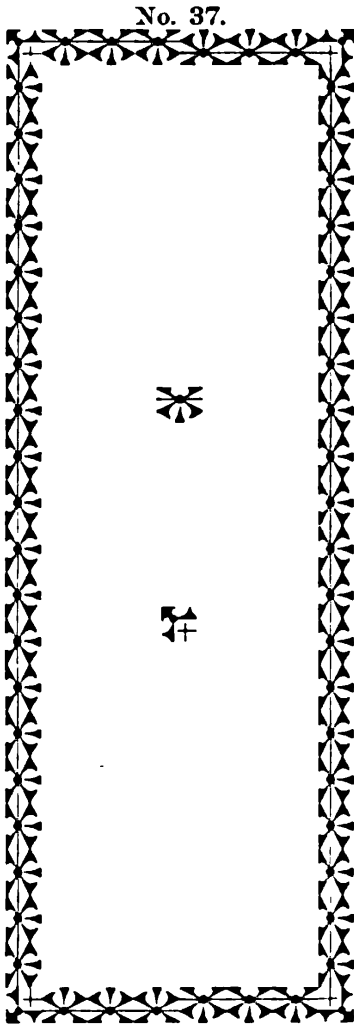

FONTS OF 6 FEET.
\$2.00 PER FONT.

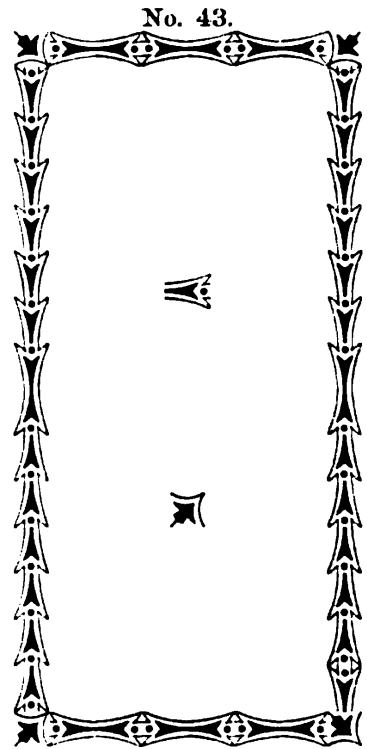
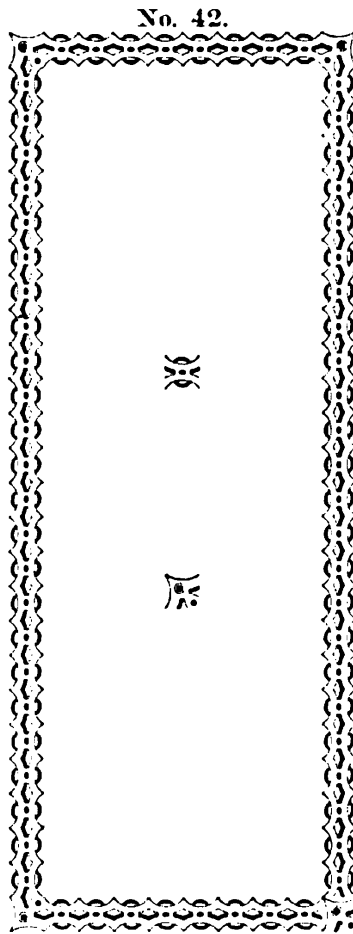
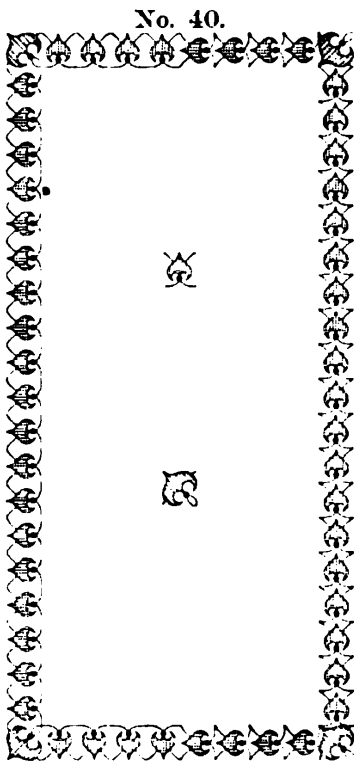

V. B. MUNSON, SUCCESSOR TO
GEO. BRUCE'S SON & CO., 13 CHAMBERS STREET, NEW YORK.

NINE POINT BORDERS

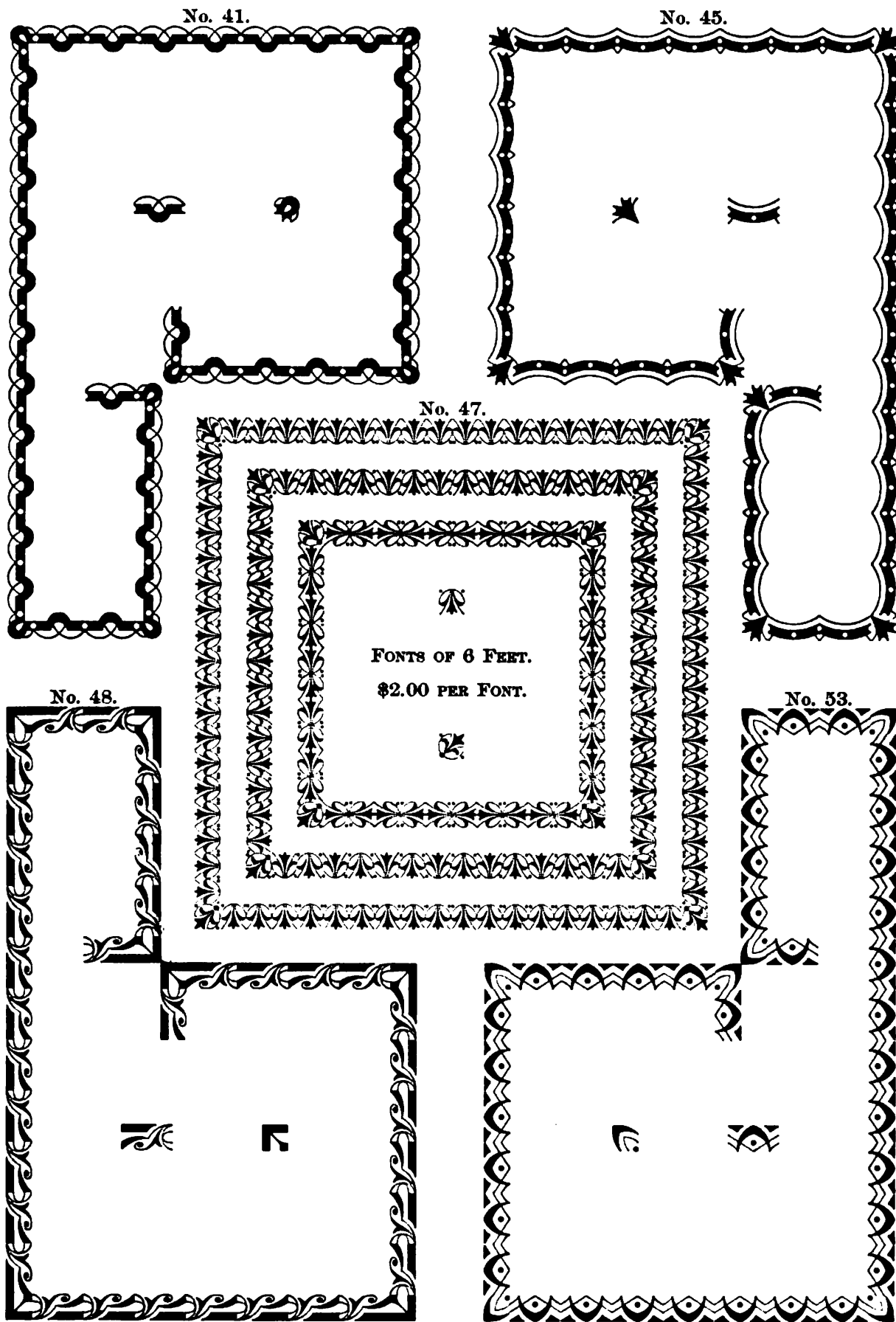

V. B. MUNSON, SUCCESSOR TO
GEO. BRUCE'S SON & CO., 13 CHAMBERS STREET, NEW YORK.

NINE POINT BORDERS

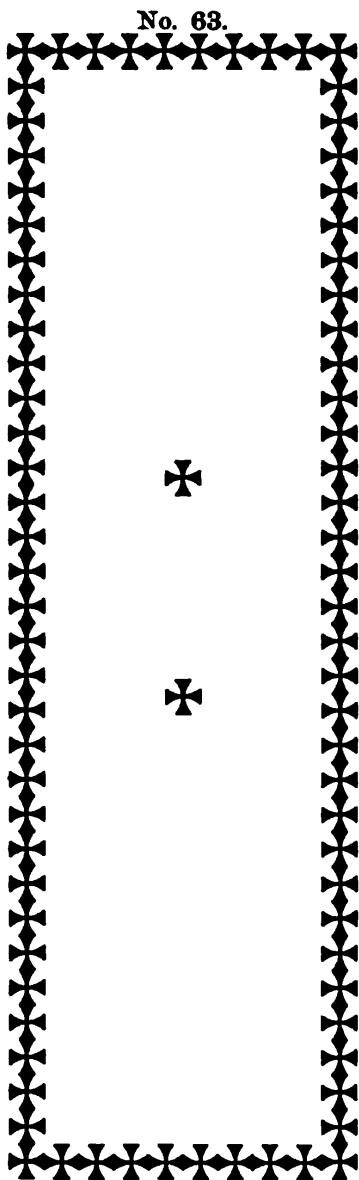
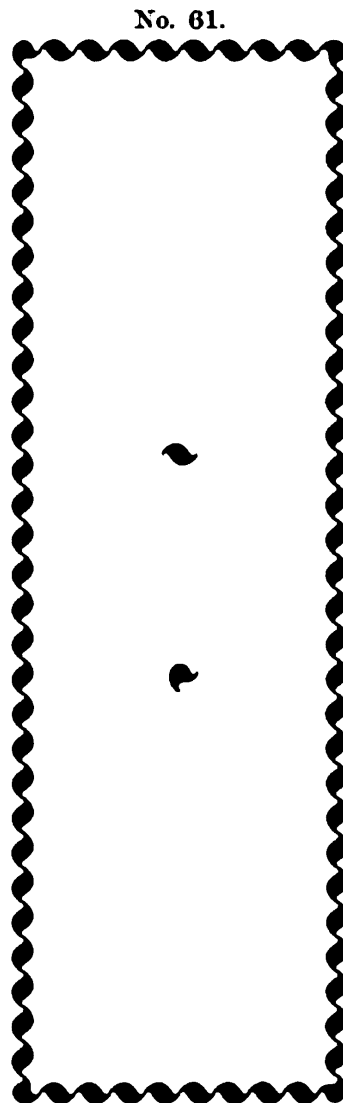
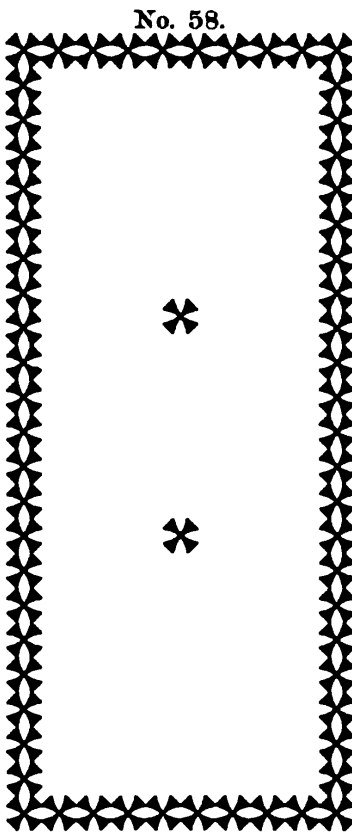
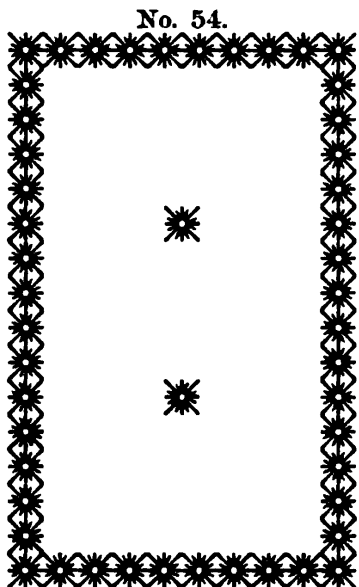

FONTS OF 6 FEET.
\$2.00 PER FONT.

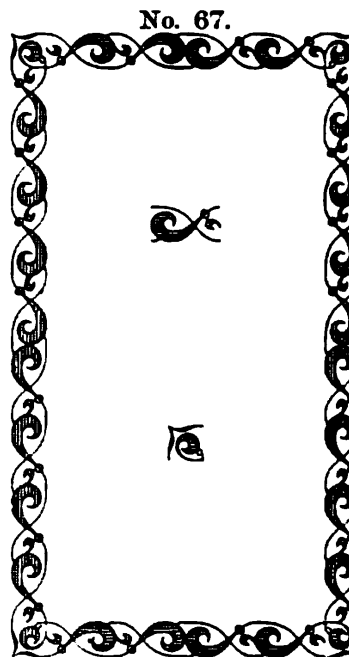
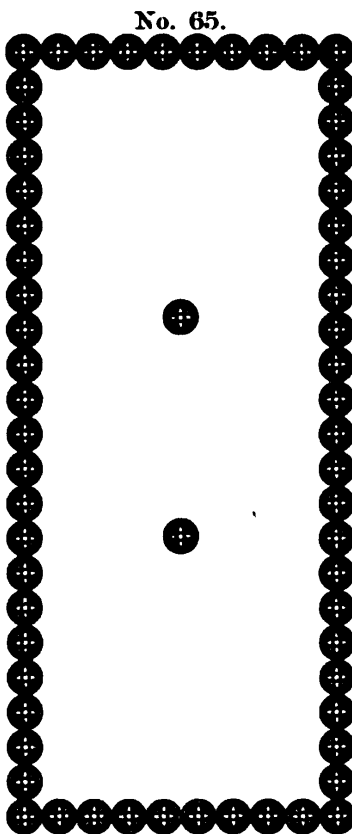

V. B. MUNSON, SUCCESSOR TO
GEO. BRUCE'S SON & CO., 13 CHAMBERS STREET, NEW YORK.

TWELVE POINT BORDERS

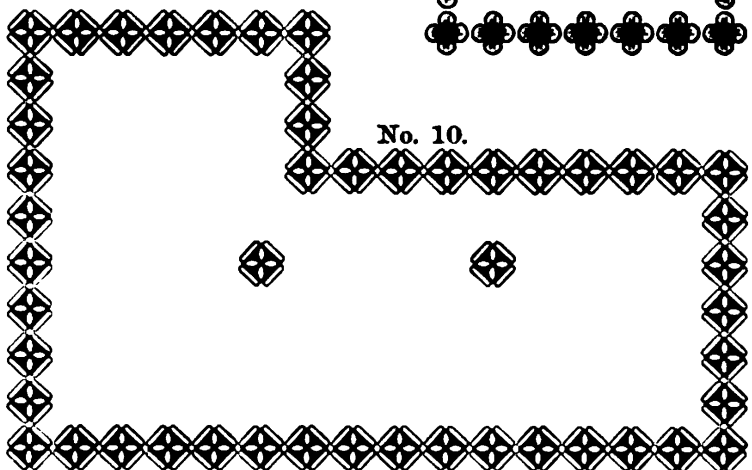
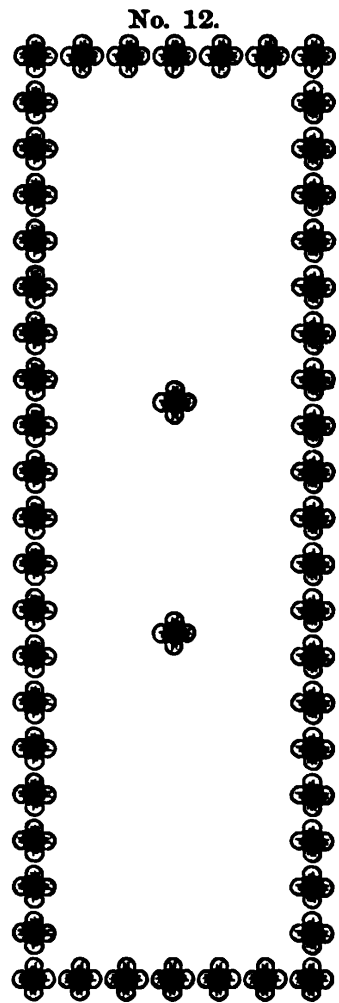
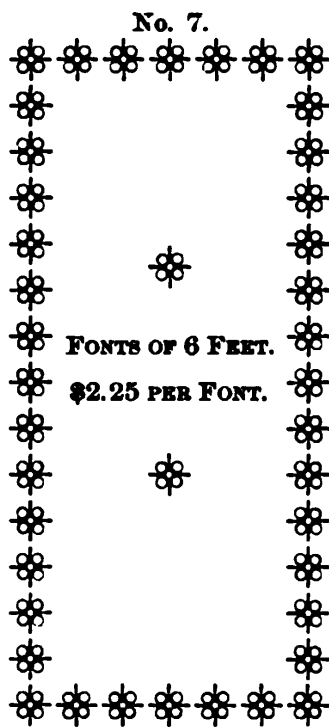
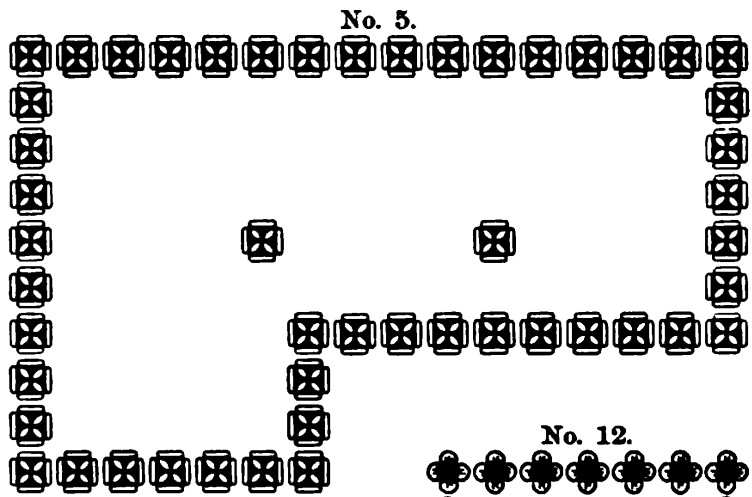
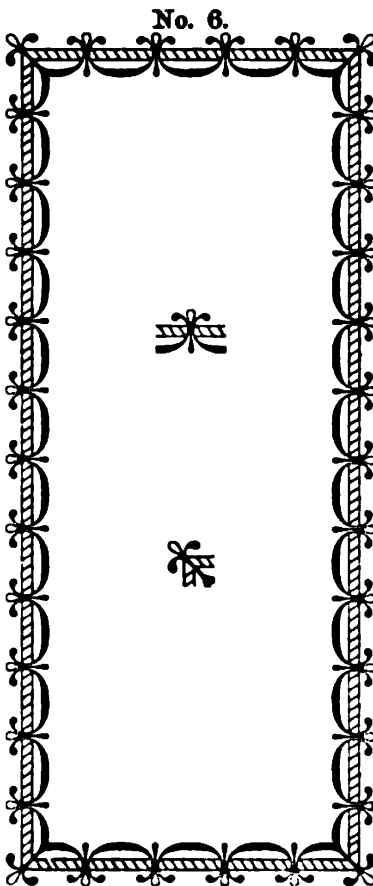
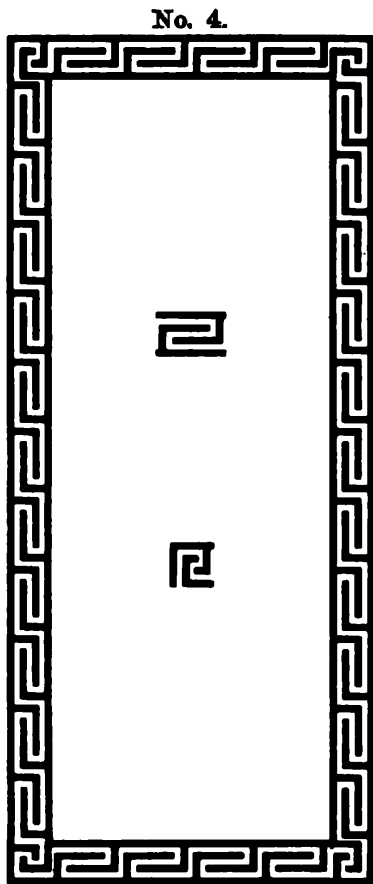

V. B. MUNSON, SUCCESSOR TO
GEO. BRUCE'S SON & CO., 13 CHAMBERS STREET, NEW YORK.

TWELVE POINT BORDERS

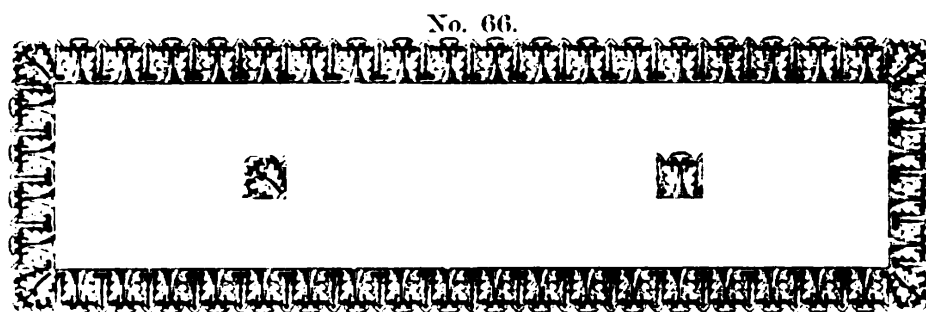
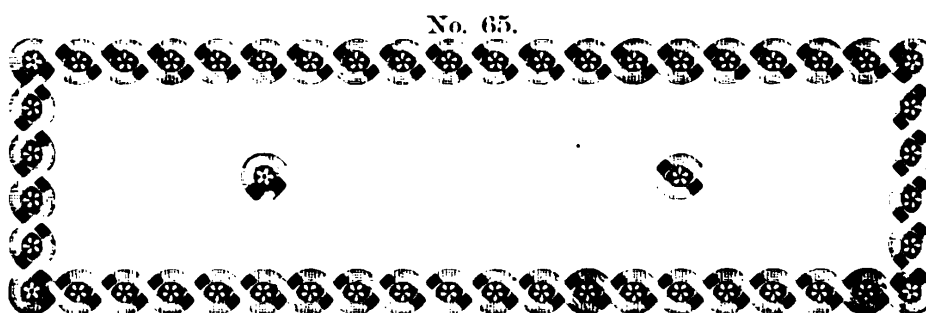
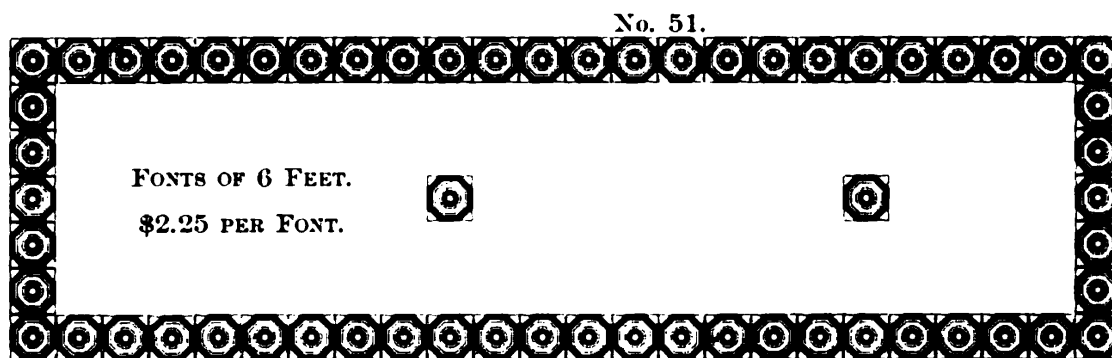
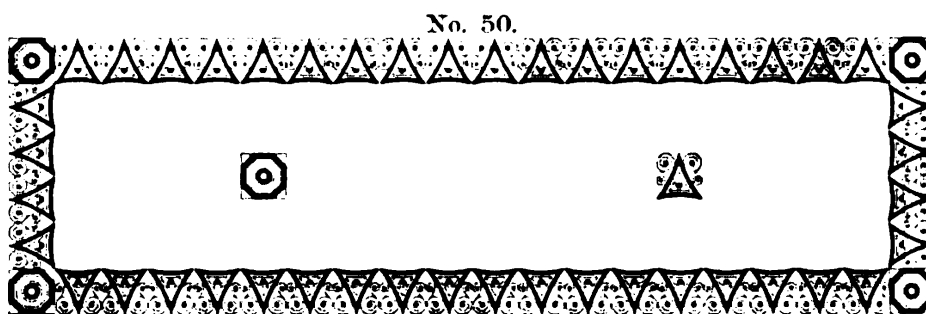
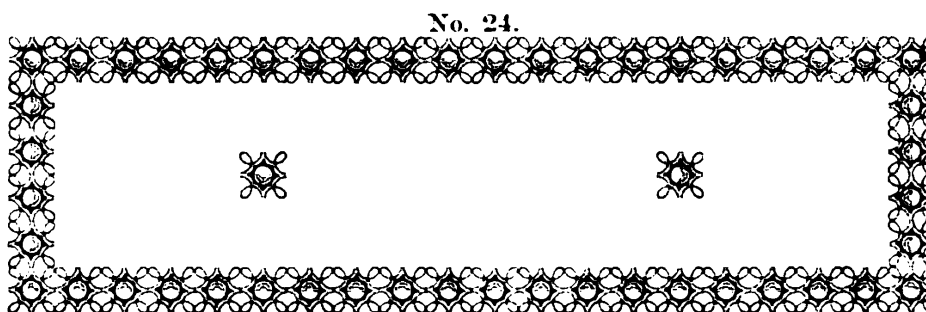
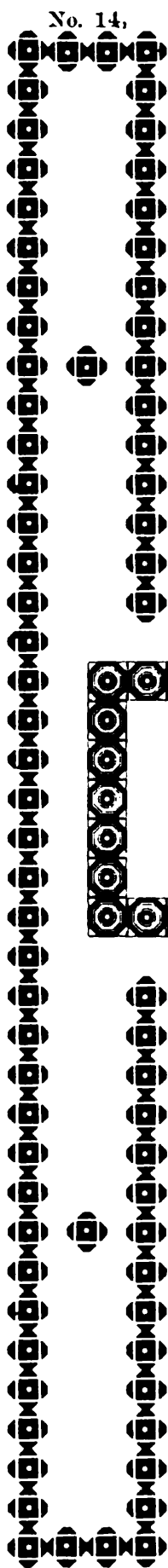

V. B. MUNSON, SUCCESSOR TO
GEO. BRUCE'S SON & CO., 13 CHAMBERS STREET, NEW YORK.

TWELVE POINT BORDERS

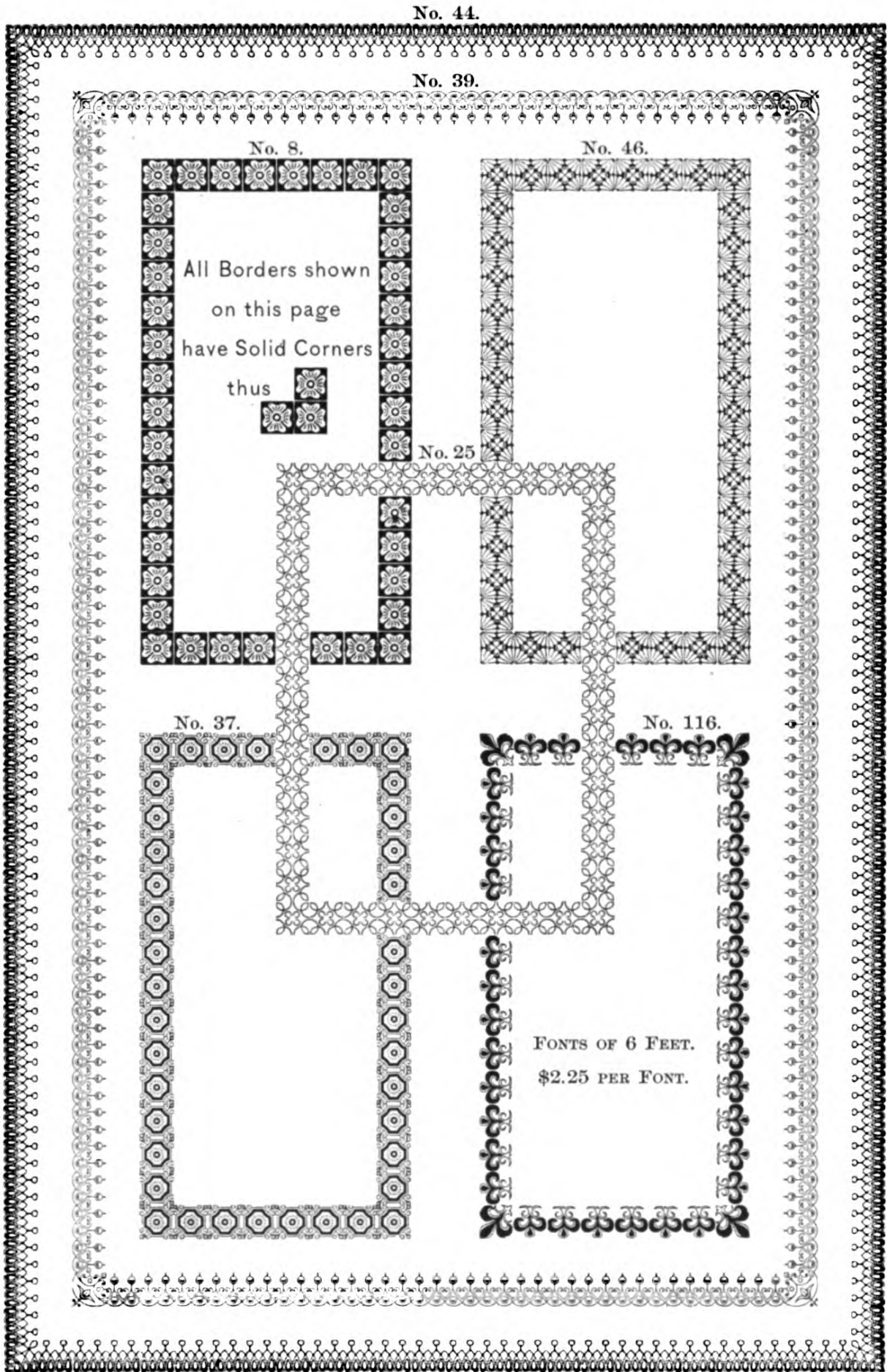

V. B. MUNSON, SUCCESSOR TO
GEO. BRUCE'S SON & CO., 13 CHAMBERS STREET, NEW YORK.

TWELVE POINT BORDERS

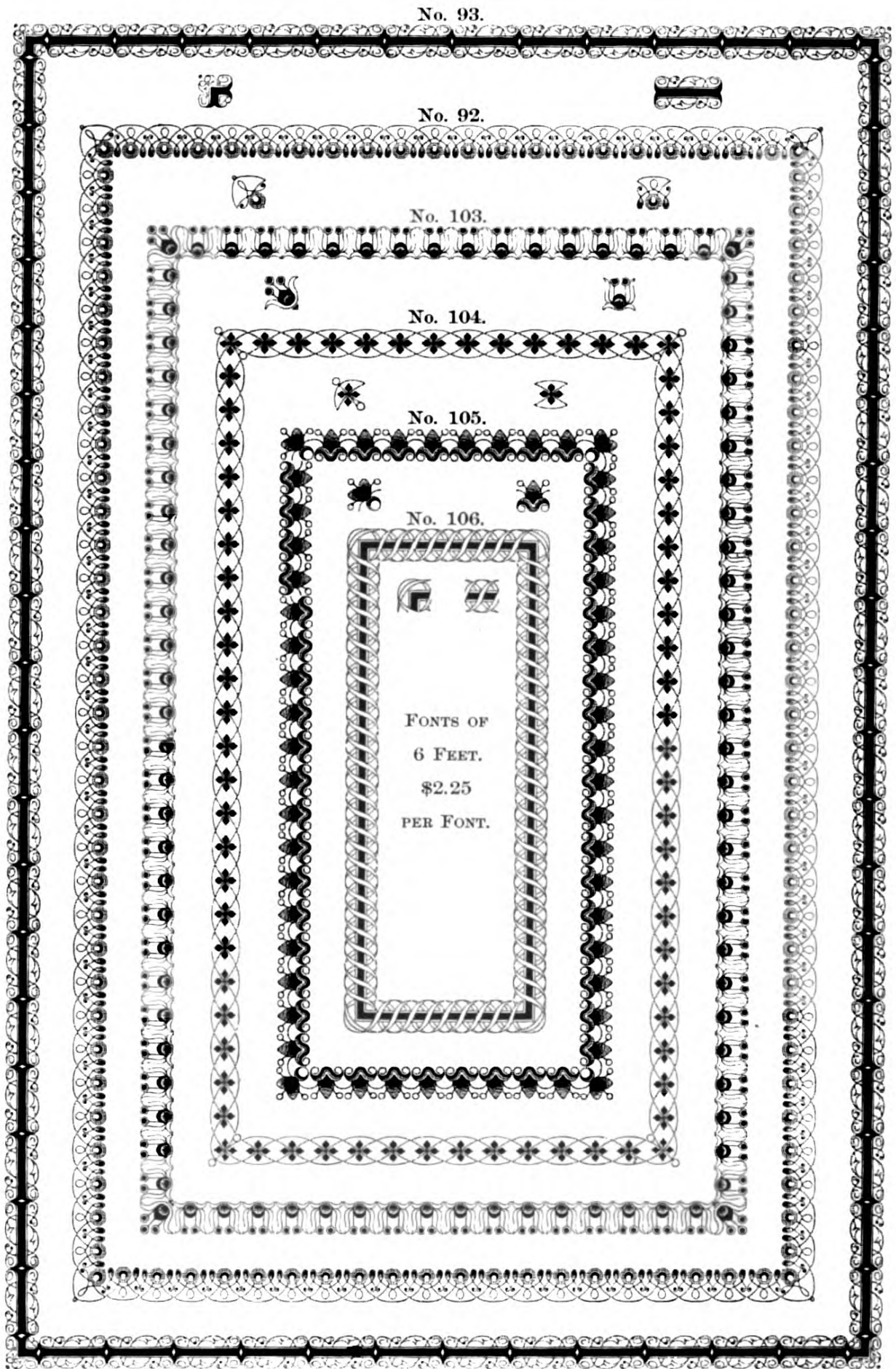

V. B. MUNSON, SUCCESSOR TO
GEO. BRUCE'S SON & CO., 13 CHAMBERS STREET, NEW YORK.

TWELVE POINT BORDERS

No. 100.



No. 112.

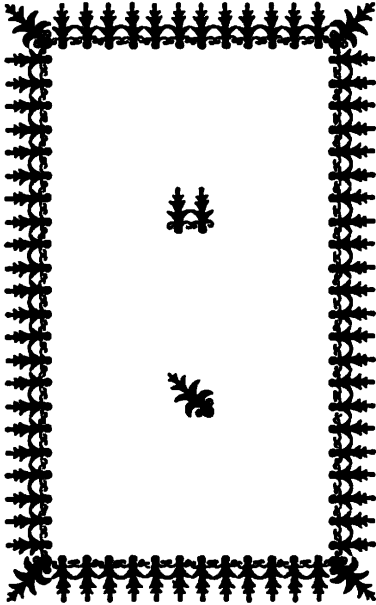

No. 113.

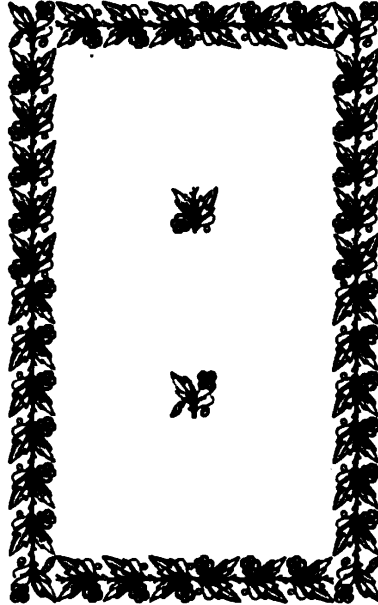

No. 114.

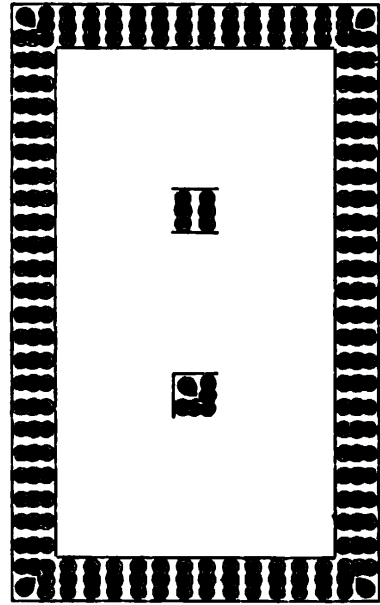

No. 115.



No. 117.

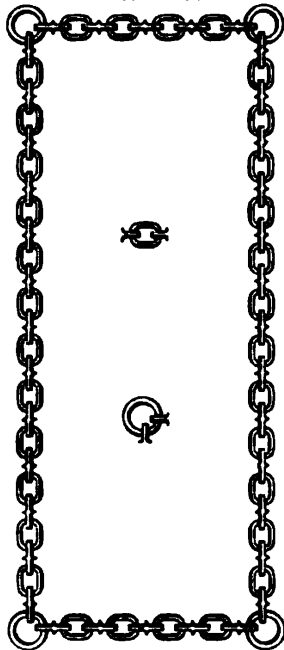

No. 118.

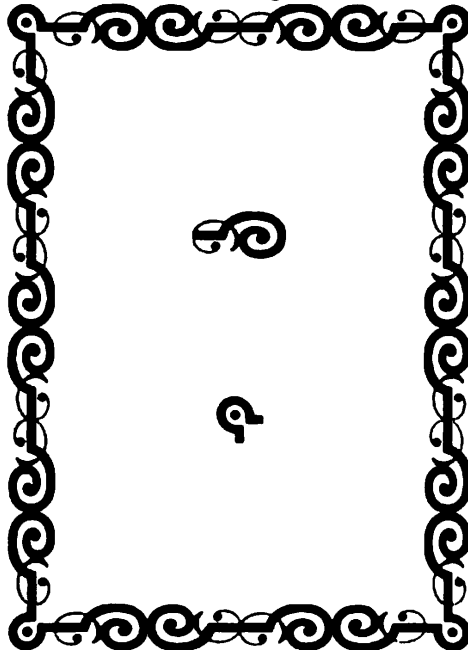

No. 119.

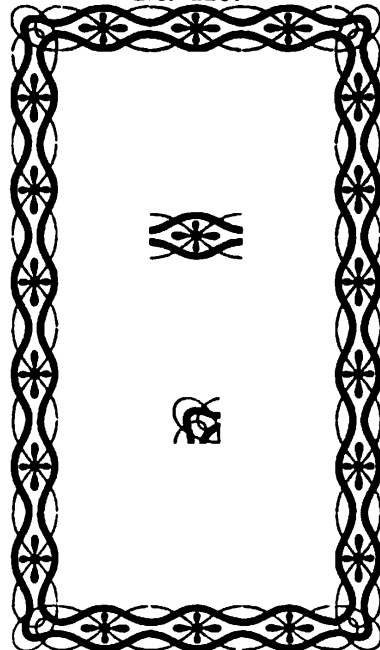

V. B. MUNSON, SUCCESSOR TO
GEO. BRUCE'S SON & CO., 13 CHAMBERS STREET, NEW YORK.

TWELVE POINT BORDERS

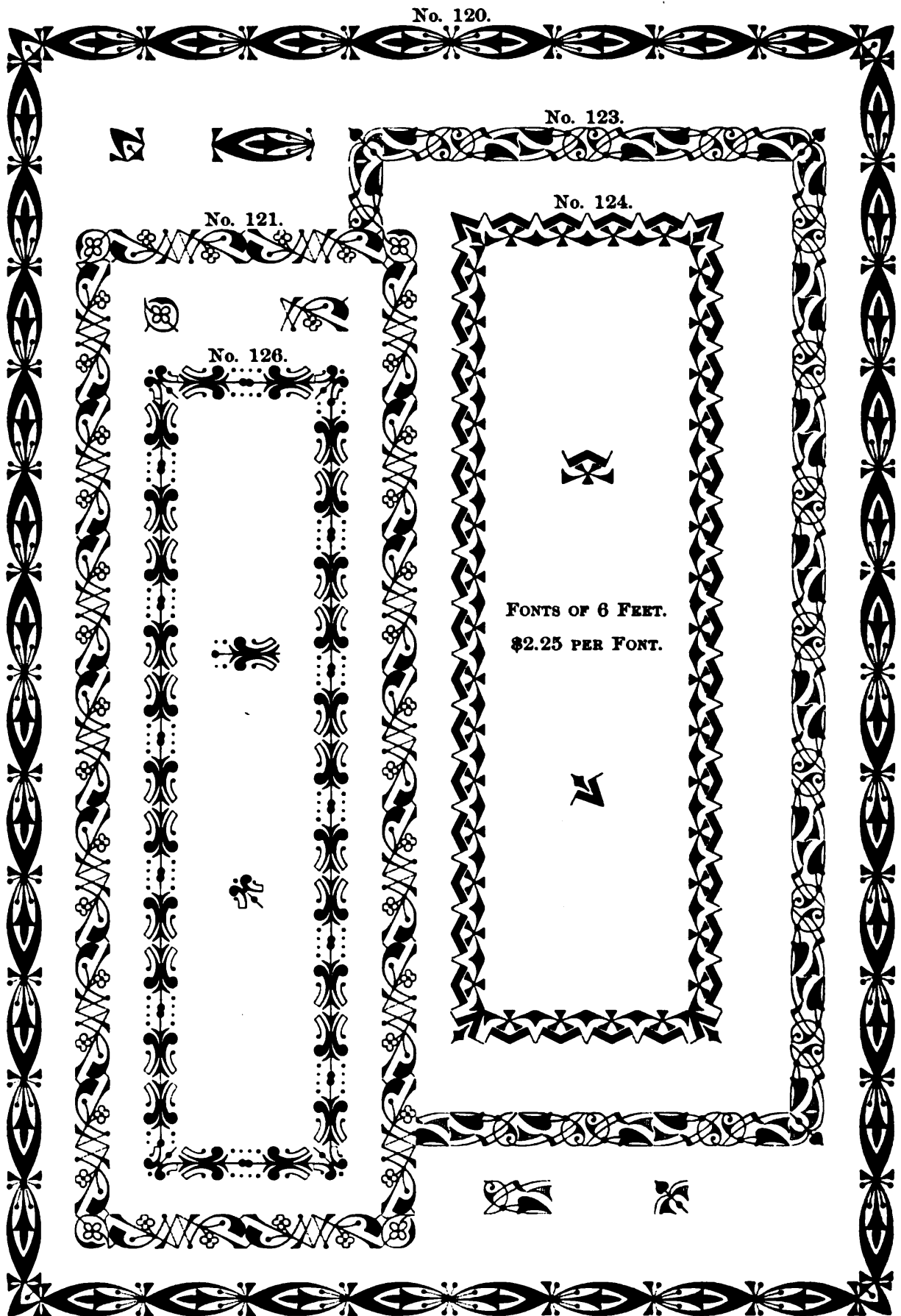

V. B. MUNSON, SUCCESSOR TO
GEO. BRUCE'S SON & CO., 13 CHAMBERS STREET, NEW YORK.

TWELVE POINT BORDERS

No. 127.

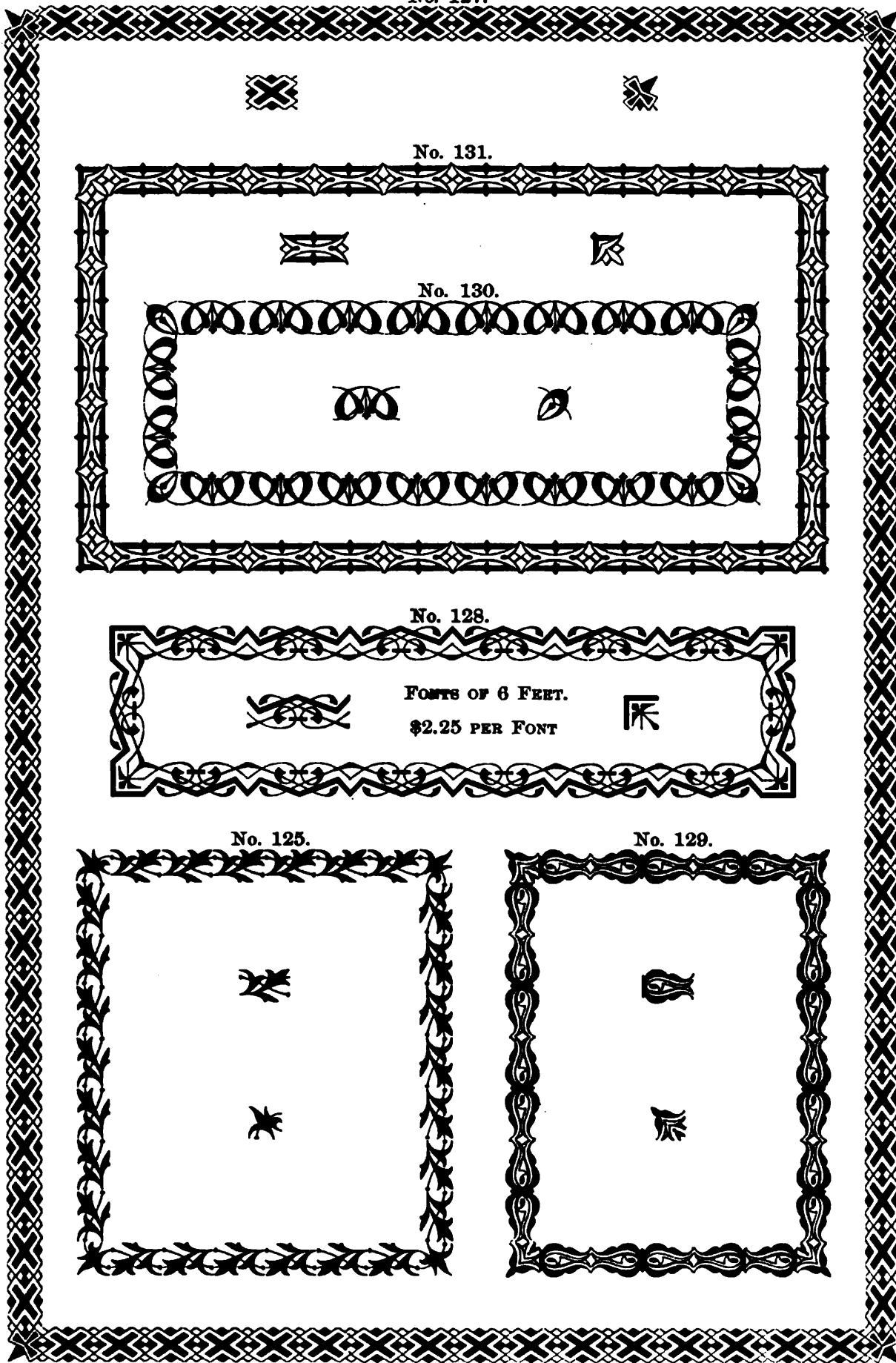

V. B. MUNSON, SUCCESSOR TO
GEO. BRUCE'S SON & CO., 13 CHAMBERS STREET, NEW YORK.

TWELVE POINT BORDERS

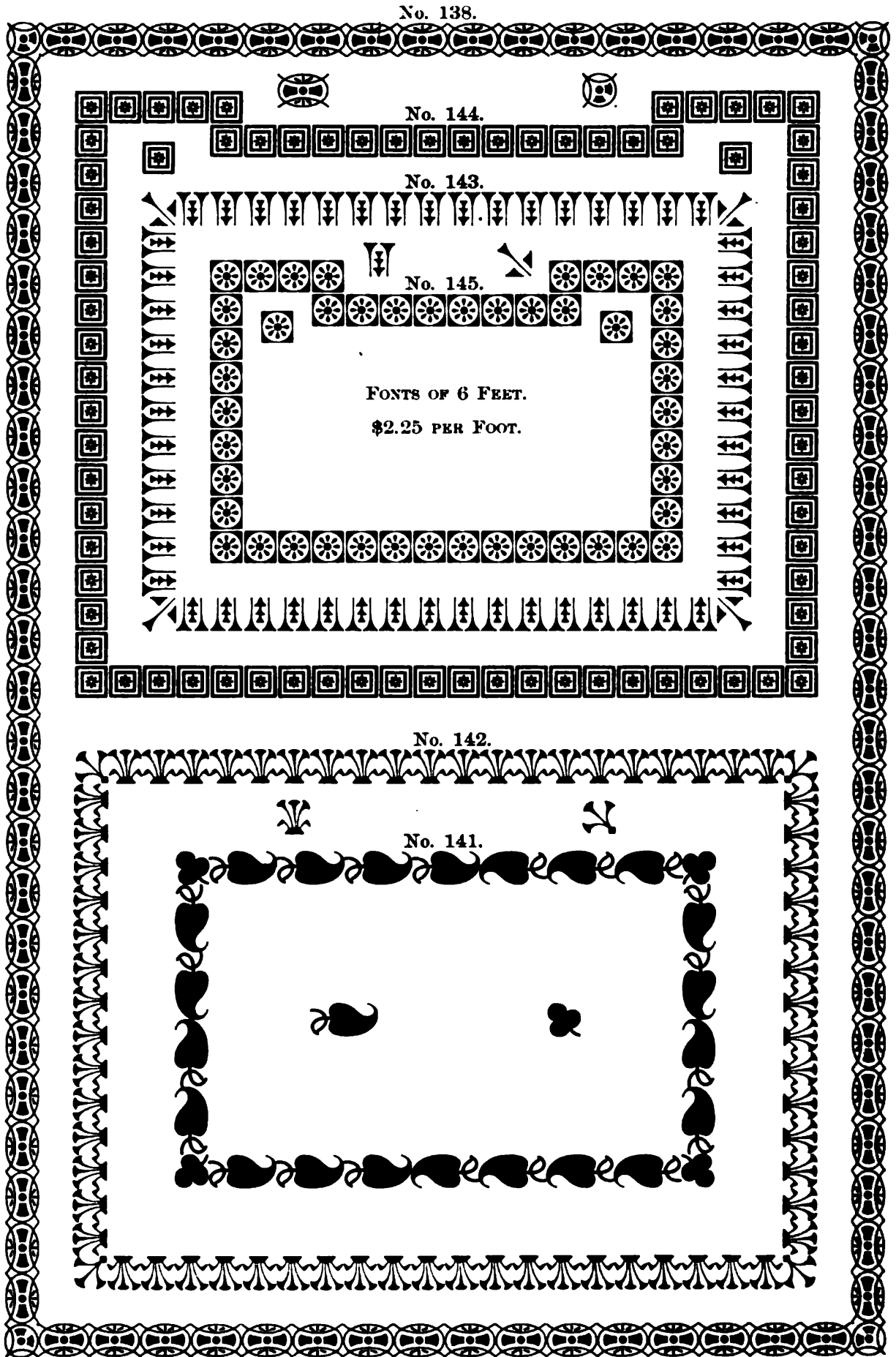

V. B. MUNSON, SUCCESSOR TO
GEO. BRUCE'S SON & CO., 13 CHAMBERS STREET, NEW YORK.

TWELVE POINT BORDERS

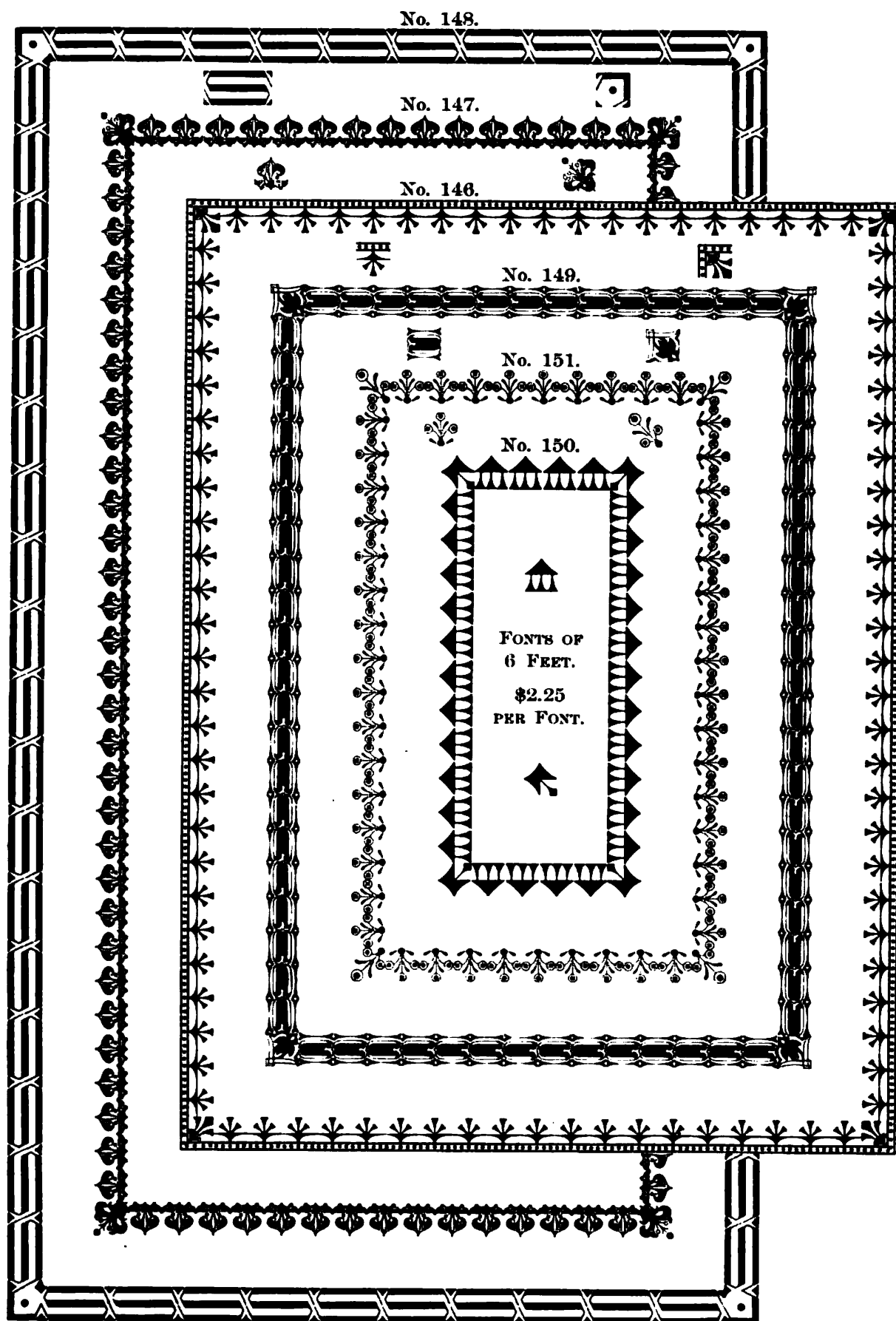

V. B. MUNSON, SUCCESSOR TO
GEO. BRUCE'S SON & CO., 13 CHAMBERS STREET, NEW YORK.

TWELVE POINT BORDERS

No. 154.

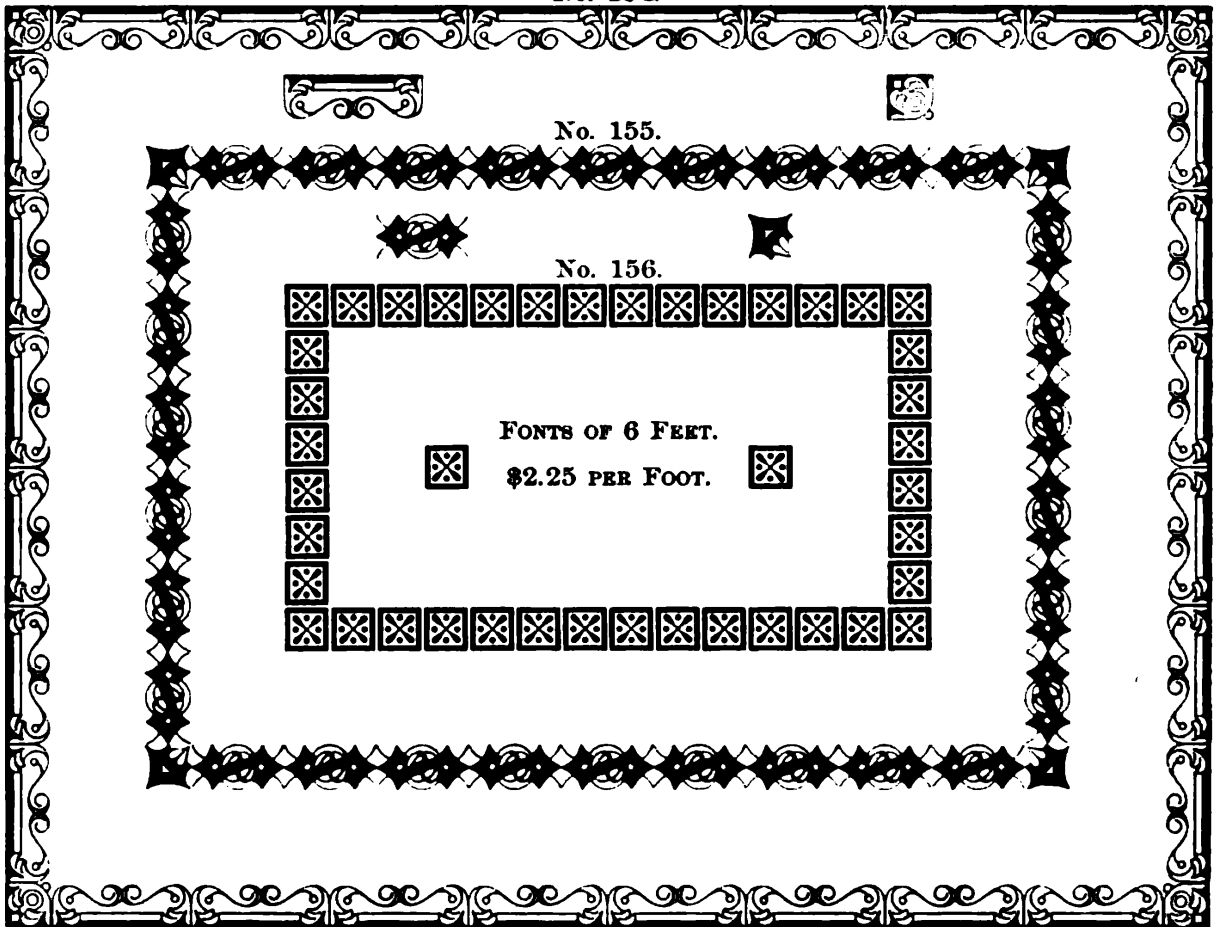

No. 152.

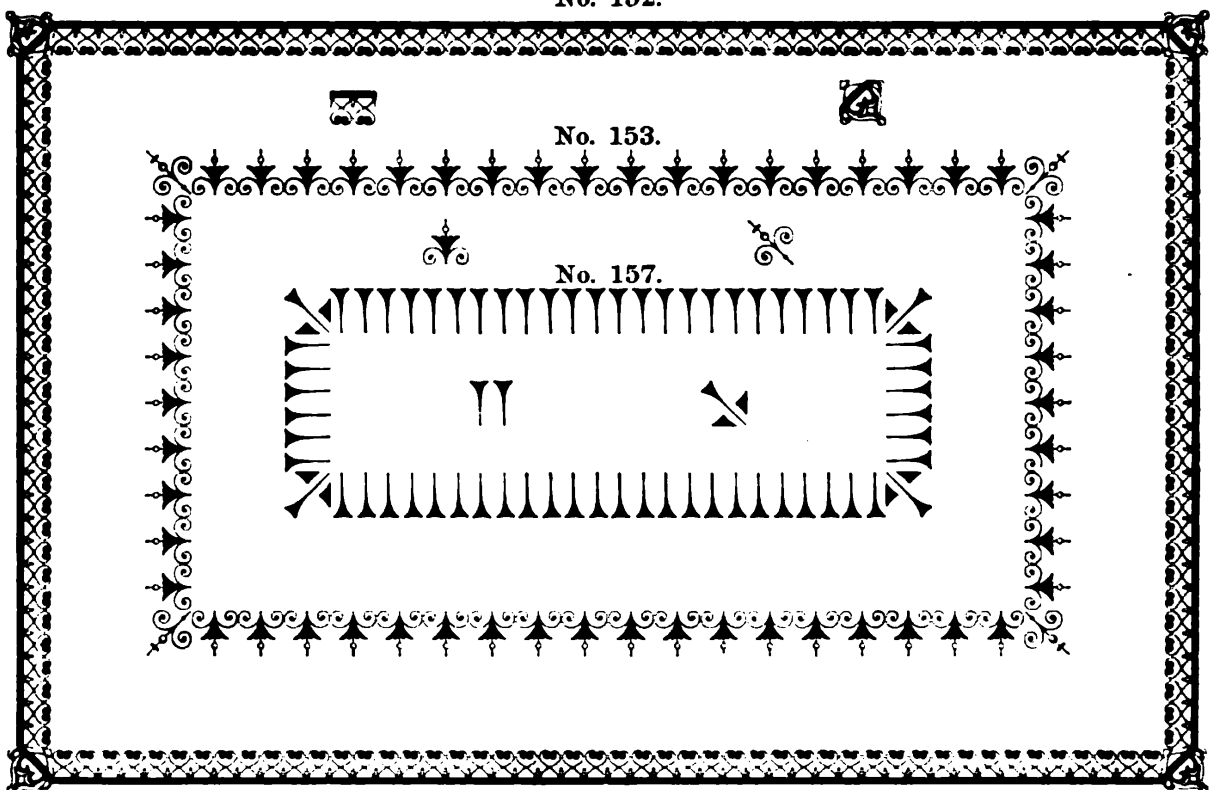

V. B. MUNSON, SUCCESSOR TO
GEO. BRUCE'S SON & CO., 18 CHAMBERS STREET, NEW YORK.

EIGHTEEN POINT BORDERS

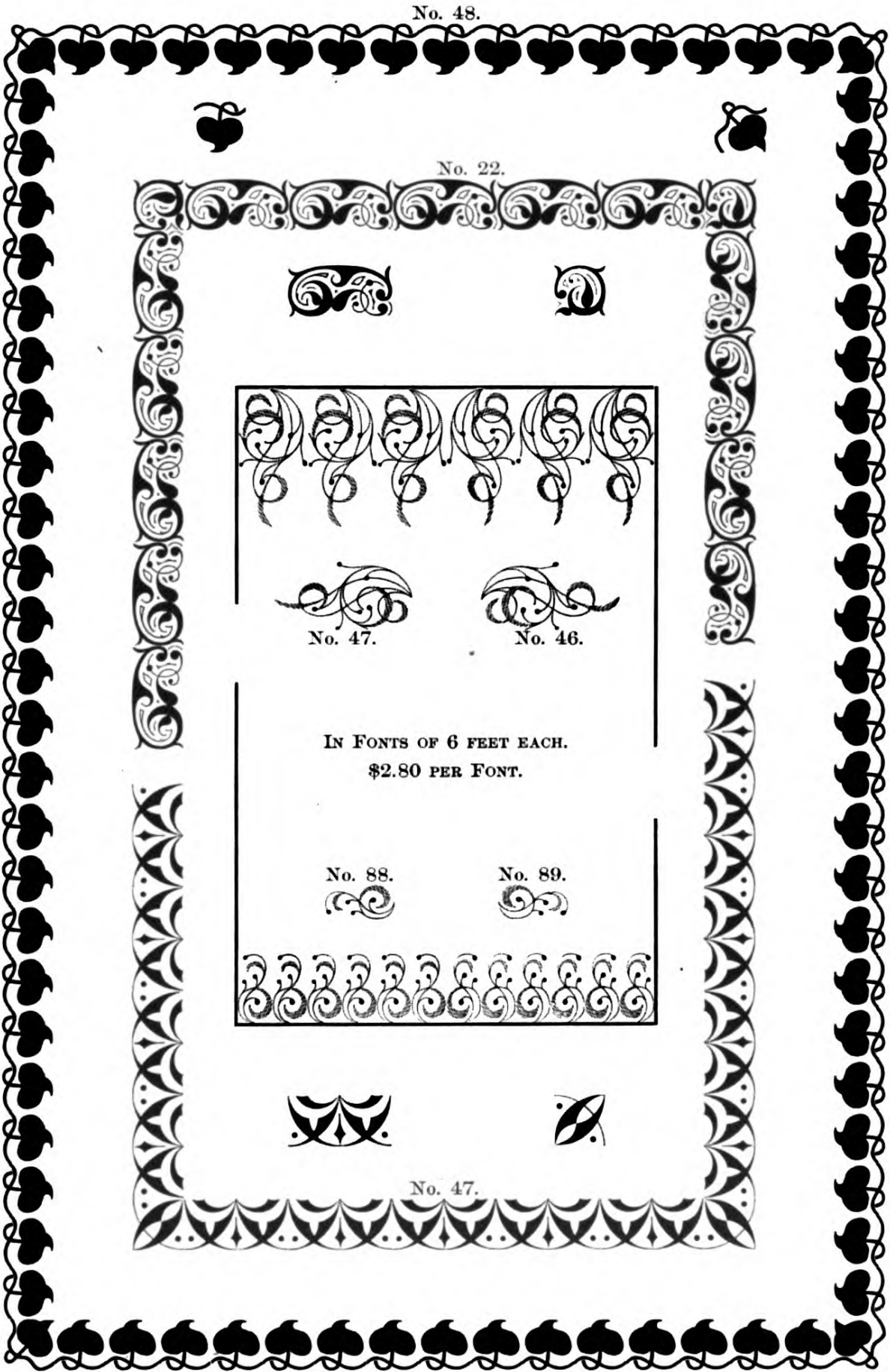

V. B. MUNSON, SUCCESSOR TO
GEO. BRUCE'S SON & CO., 13 CHAMBERS STREET, NEW YORK.

COMBINATION BORDER NO. 13

COMBINATION BORDER NO. 13

B R U E

CHARACTERS

1	2	3	4	5	6	7	8	9	10	11	12	13

THE
 SMALLEST FONT
 CONTAINS

{	35 each of Nos. 4 to 7 and 10 to 13 71 each of Nos. 2 and 9 140 pieces of No. 3 280 each of Nos. 1 and 8
---	---

PER FONT, \$5.45

V. B. MUNSON, SUCCESSOR TO
 GEO. BRUCE'S SON & CO., 13 CHAMBERS STREET, NEW YORK.

EIGHTEEN POINT BORDERS



No. 1.

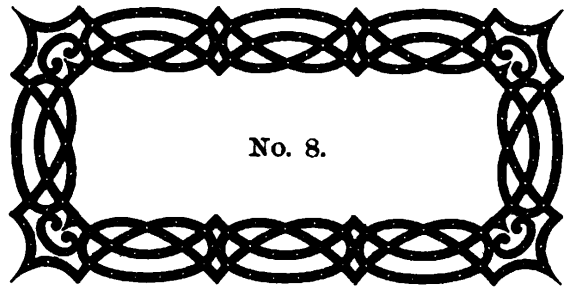

No. 8.

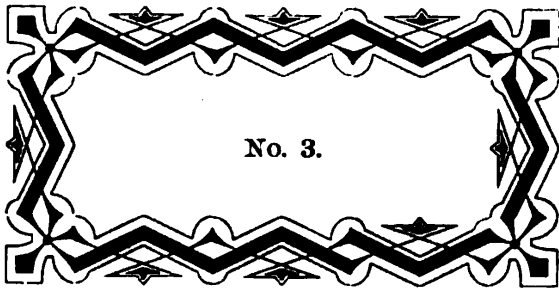

No. 3.

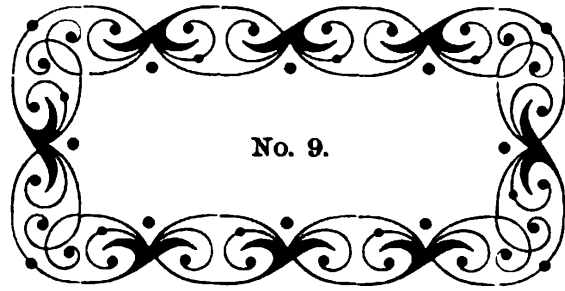

No. 9.

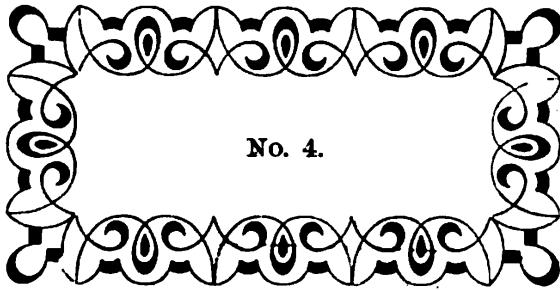

No. 4.

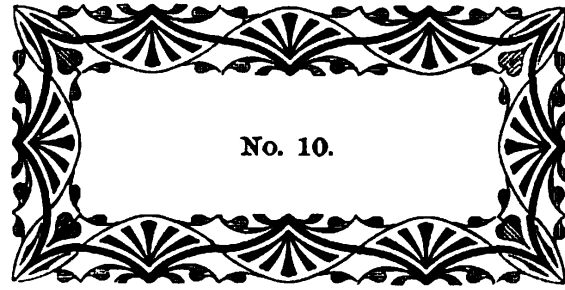

No. 10.

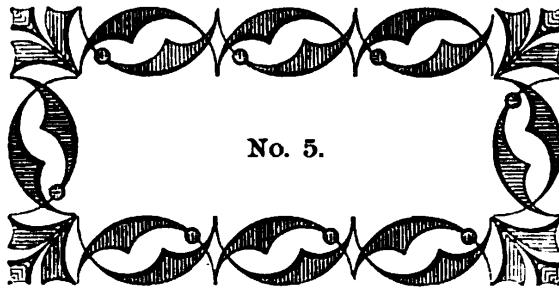

No. 5.

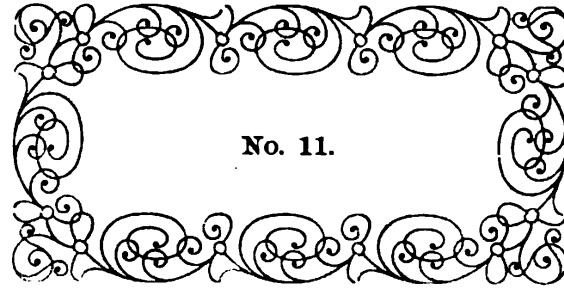

No. 11.

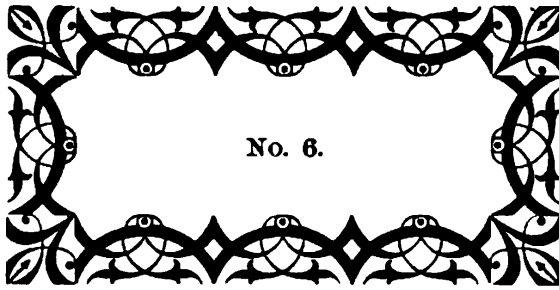

No. 6.

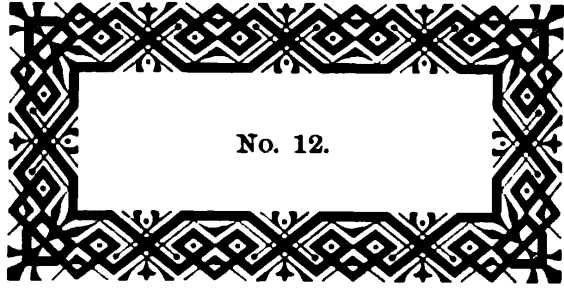

No. 12.

PUT UP IN 6 FEET FONTS. PRICE, \$2.80.

BRUCE TYPE FOUNDRY, 13 CHAMBERS STREET, NEW YORK.

EIGHTEEN POINT BORDERS

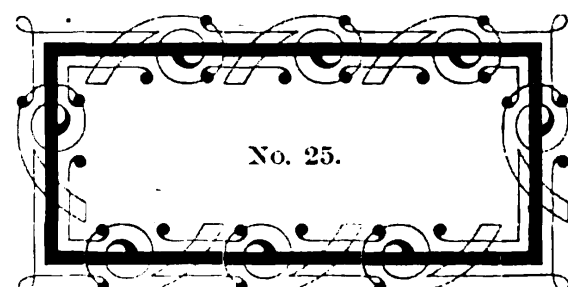
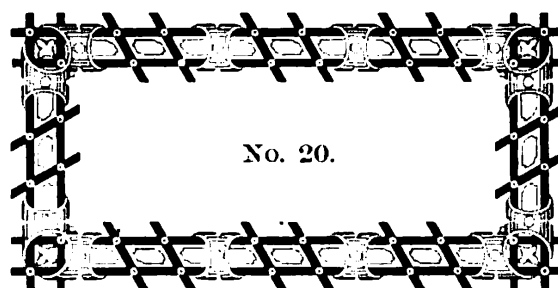
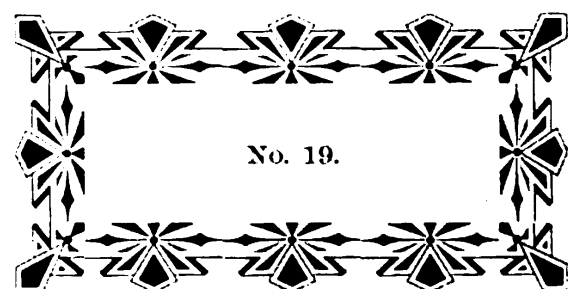
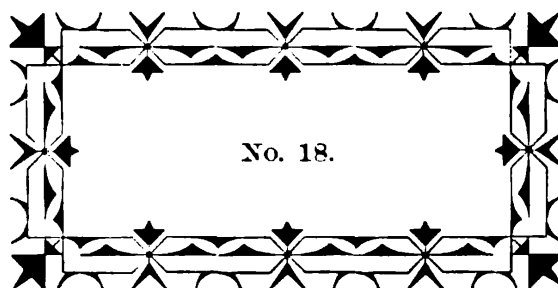
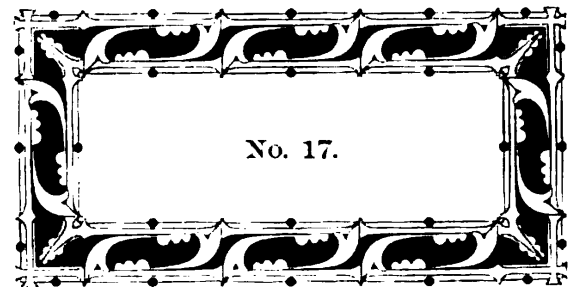
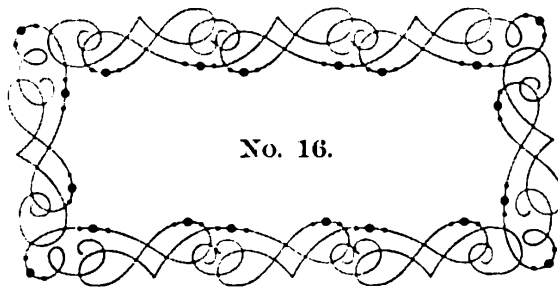
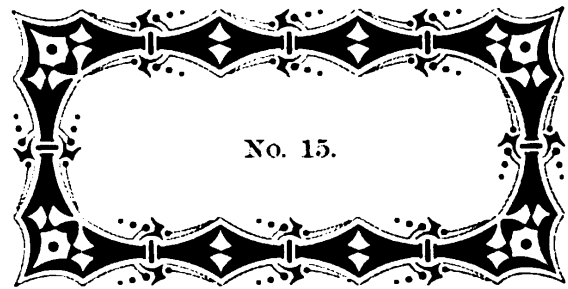
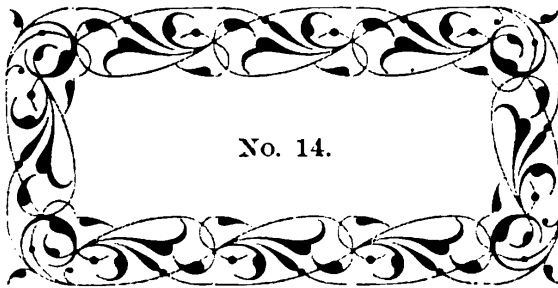
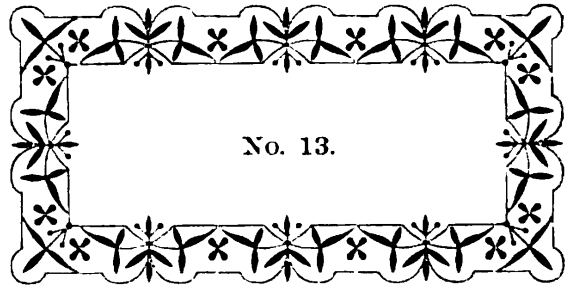
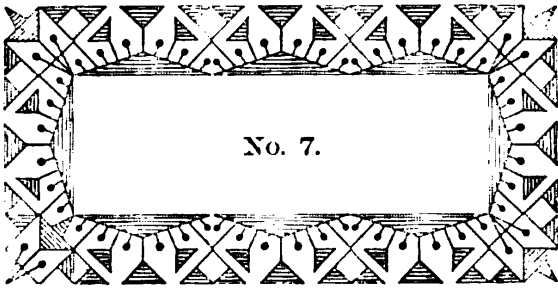

PUT UP IN 3 FEET FONTS. PRICE, \$2.80.

BRUCE TYPE FOUNDRY, 13 CHAMBERS STREET, NEW YORK.

EIGHTEEN POINT BORDERS

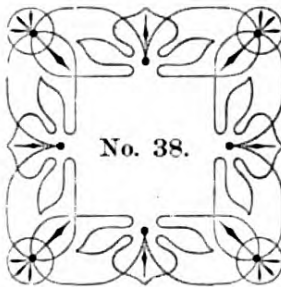

PUT UP IN 6 FEET FONTS. PRICE, \$2.80.

BRUCE TYPE FOUNDRY, 13 CHAMBERS STREET, NEW YORK.

TWENTY-FOUR POINT BORDERS

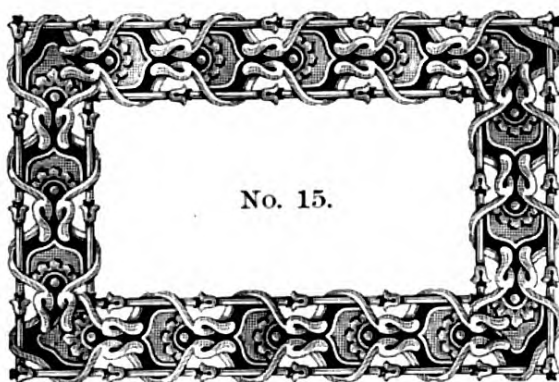

PUT UP IN 3 FEET FONTS. PRICE, \$1.65.

BRUCE TYPE FOUNDRY, 13 CHAMBERS STREET, NEW YORK.

TWENTY-FOUR POINT BORDERS

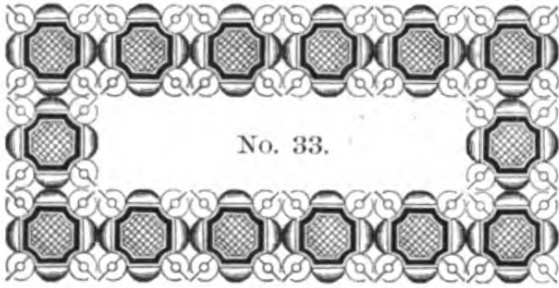

No. 33.

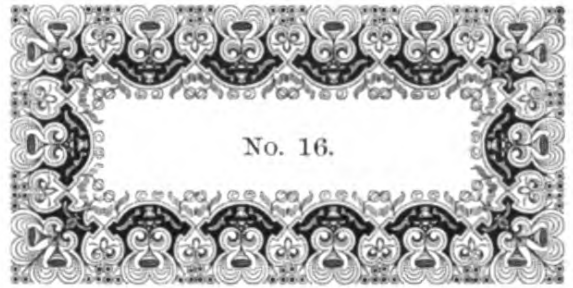

No. 16.

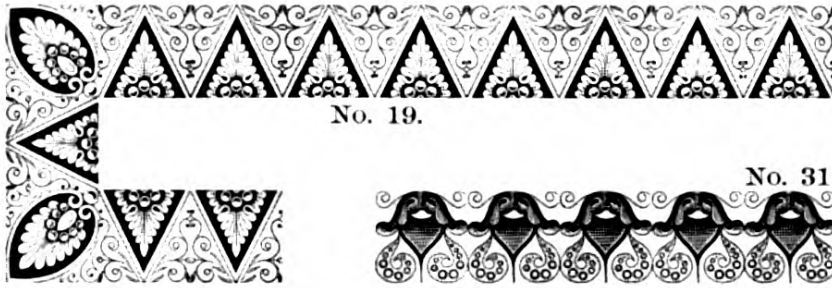

No. 19.



No. 31.



No. 26.

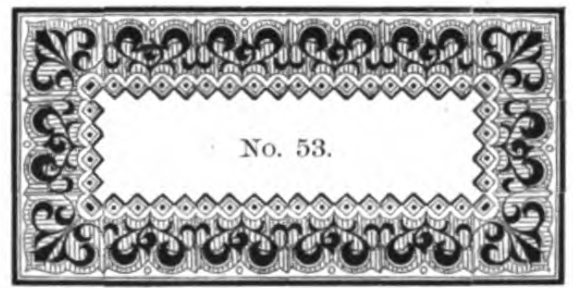

No. 53.

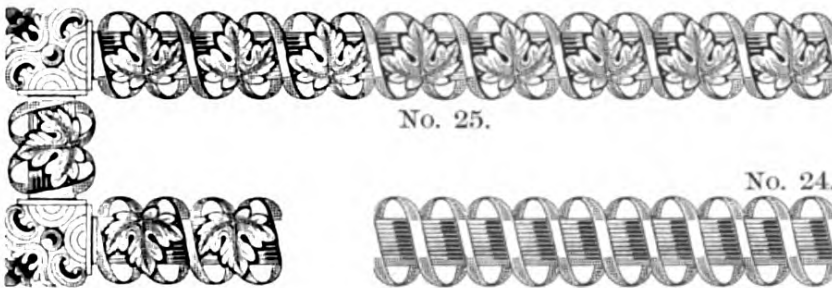

No. 25.

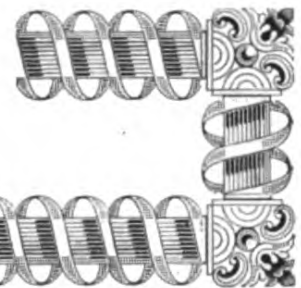

No. 24.



No. 51.

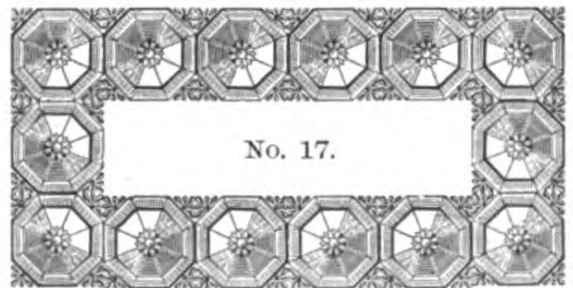

No. 17.

PUT UP IN 3 FEET FONTS. PRICE, \$1.65.

BRUCE TYPE FOUNDRY, 13 CHAMBERS STREET, NEW YORK.

TWENTY-FOUR POINT BORDERS

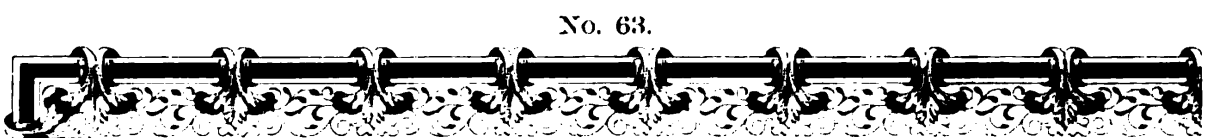
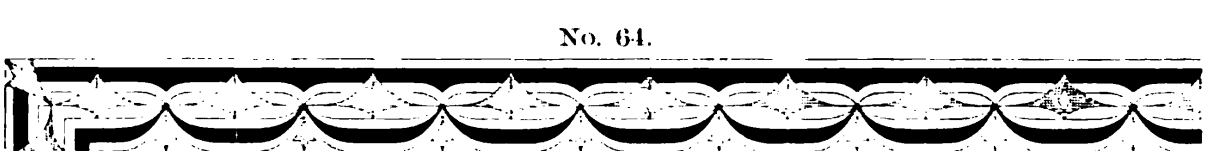
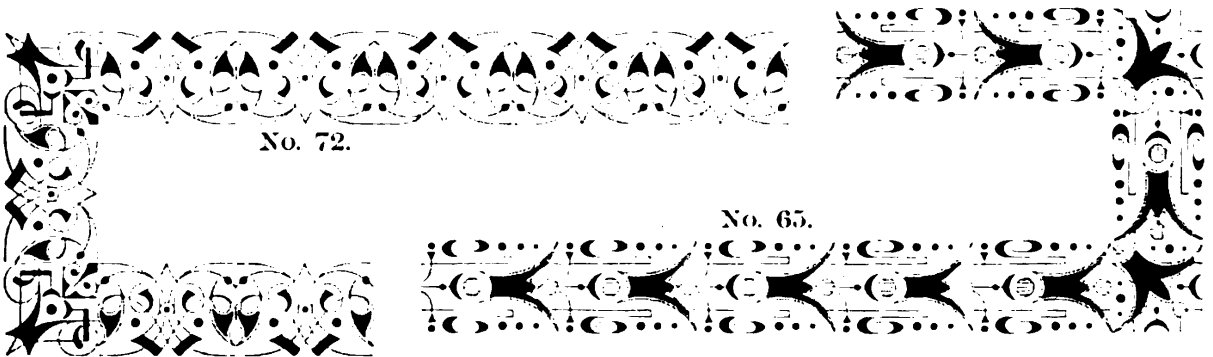
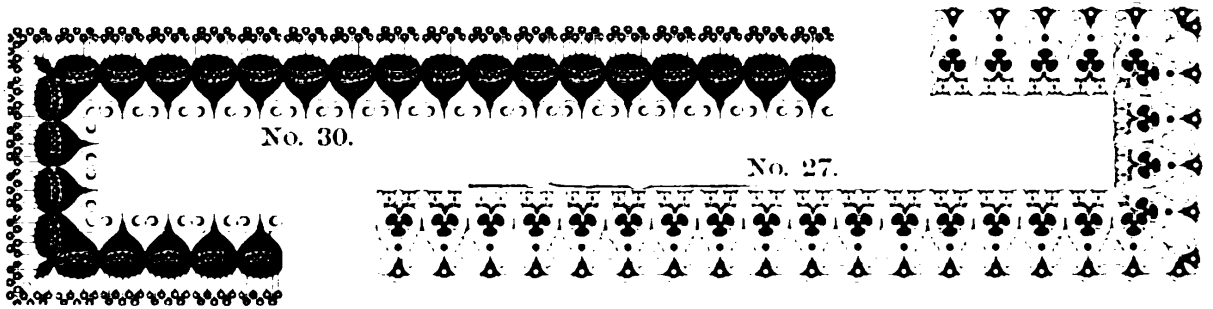
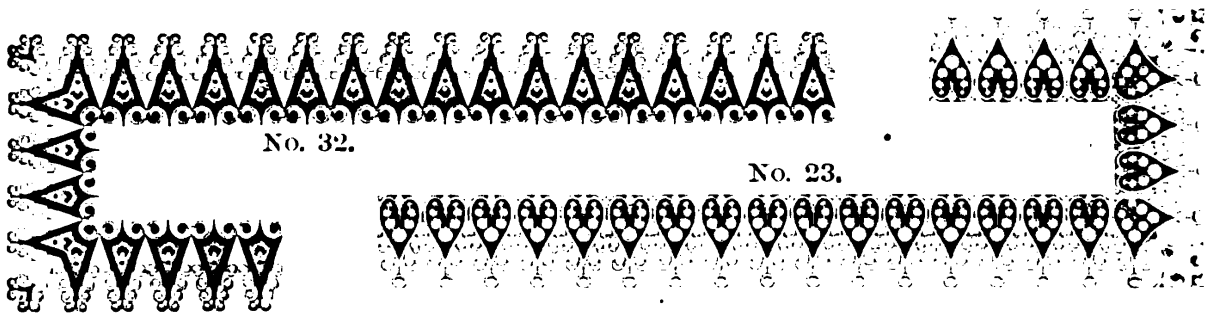

PUT UP IN 3 FEET FONTS. PRICE. \$1.65.

BRUCE TYPE FOUNDRY, 13 CHAMBERS STREET, NEW YORK.

THIRTY-SIX POINT BORDERS

No. 1

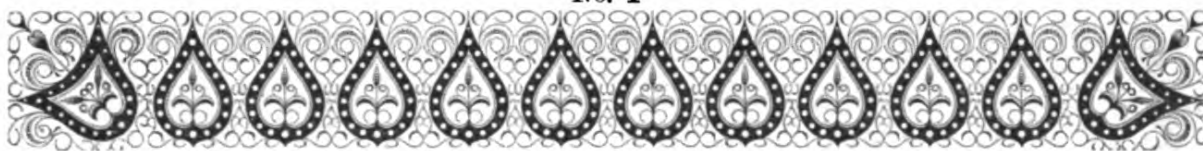

No. 3



No. 4



No. 6



No. 5



No. 7



No. 8



PUT UP IN 3 FEET FONTS. PRICE, \$2.25.

BRUCE TYPE FOUNDRY, 13 CHAMBERS STREET, NEW YORK.

THIRTY-SIX POINT BORDERS

No. 11



No. 14



No. 15



No. 23



No. 24



No. 19



No. 20



PUT UP IN 3 FEET FONTS. PRICE, \$2.25.

BRUCE TYPE FOUNDRY, 13 CHAMBERS STREET, NEW YORK.

THIRTY-SIX POINT BORDERS



No. 17.



No. 21

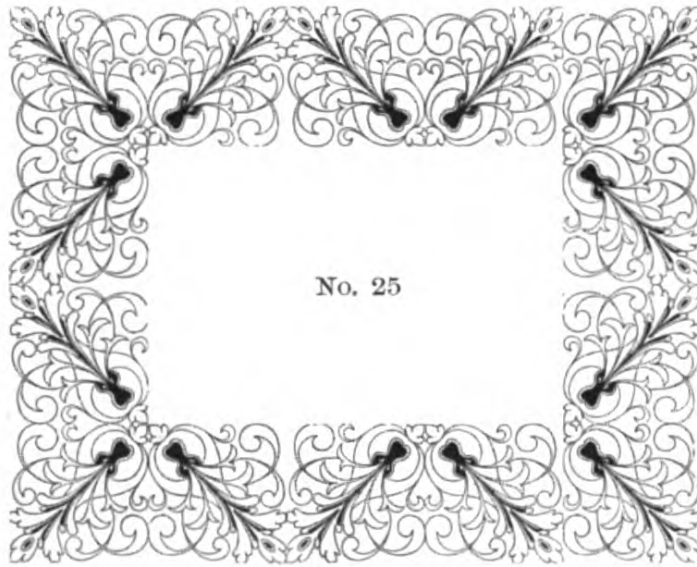

No. 25

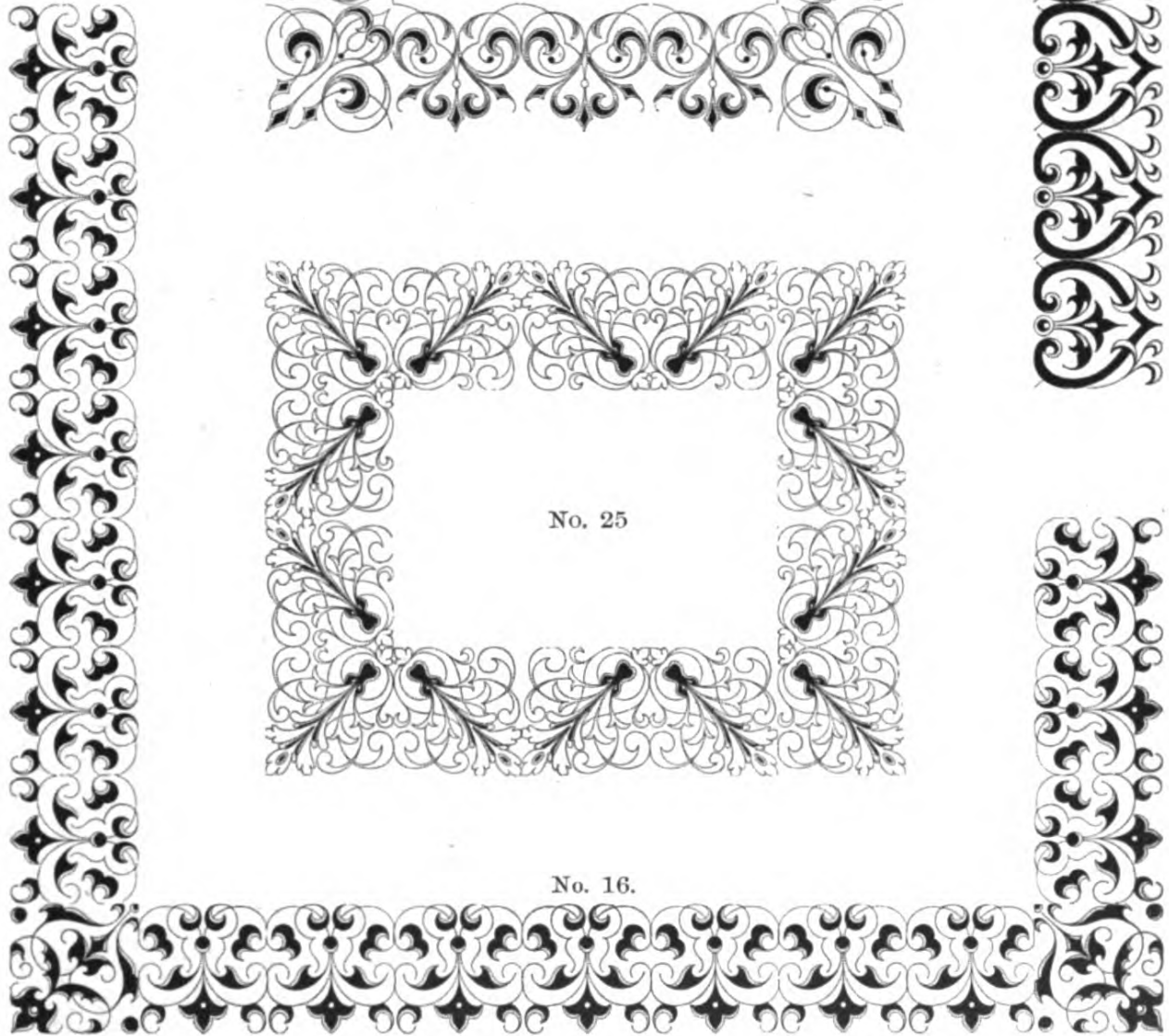

No. 16.

PUT UP IN 3 FEET FONTS. PRICE, \$2.25.

BRUCE TYPE FOUNDRY, 13 CHAMBERS STREET, NEW YORK.

FORTY-EIGHT POINT BORDERS

No. 6.



No. 7.



No. 8.



No. 11.



No. 21.



No. 22.



No. 24.



PUT UP IN 1 FOOT FONTS. PRICE, \$1.50.

BRUCE TYPE FOUNDRY, 13 CHAMBERS STREET, NEW YORK.

FORTY-EIGHT POINT BORDERS

No. 17.



No. 18.



No. 19.



No. 20.



No. 26.



No. 28.



No. 29.



PUT UP IN 1 FOOT FONTS. PRICE, \$1.50.

BRUCE TYPE FOUNDRY, 13 CHAMBERS STREET, NEW YORK.

FORTY-EIGHT POINT BORDERS

No. 25.



No. 27.



No. 33.



No. 34.



No. 35.



No. 12.



No. 16



PUT UP IN 1 FOOT FONTS. PRICE, \$1.50.

BRUCE TYPE FOUNDRY, 13 CHAMBERS STREET, NEW YORK.

FORTY-EIGHT POINT BORDERS

No. 32.



No. 36.



No. 41.



No. 13.



No. 14.



No. 15.



No. 23.



PUT UP IN 1 FOOT FONTS. PRICE, \$1.50.

BRUCE TYPE FOUNDRY, 13 CHAMBERS STREET, NEW YORK.

SIXTY POINT COMBINATION BANDS OR BORDERS

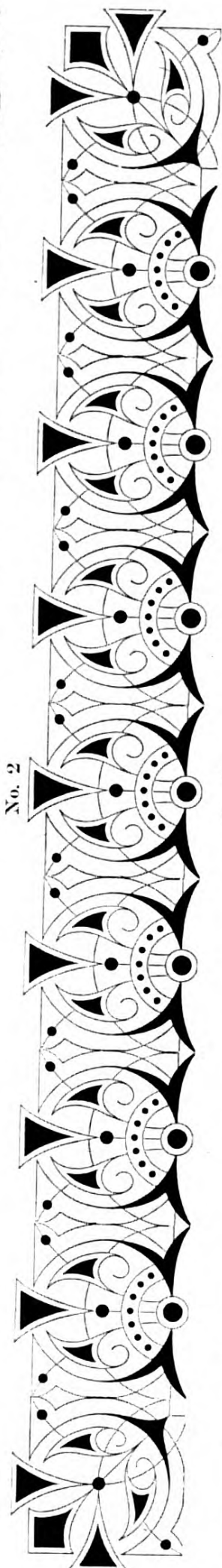

PUT UP IN 1 FOOT FONTS. PRICE, \$1.75

SIXTY POINT COMBINATION BANDS OR BORDERS

No. 10.



No. 6.



No. 11.



No. 5.



PUT UP IN 1 FOOT FONTS. PRICE, \$1.75.

SIXTY POINT COMBINATION BANDS OR BORDERS

No. 7.

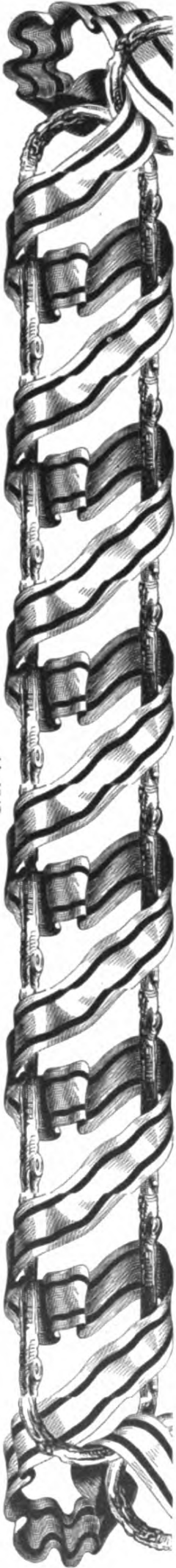

No. 9.



No. 12.



No. 13.

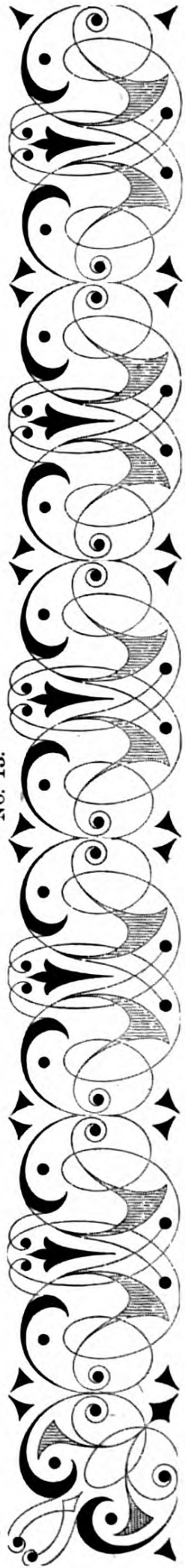

PUT UP IN 1 FOOT FONTS. PRICE, \$1.50

COMBINATION BORDER NO. 16

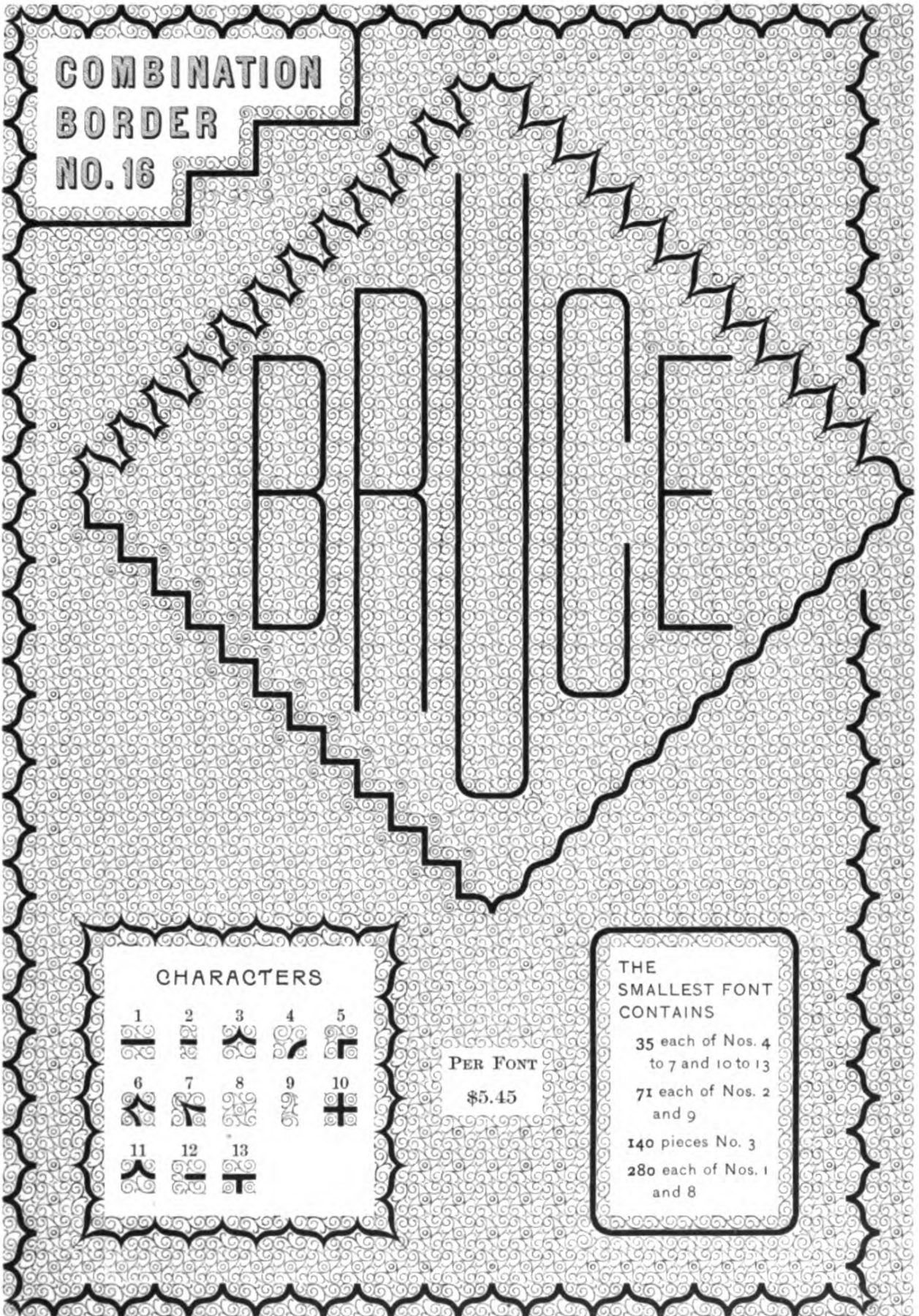

COMBINATION
BORDER
NO. 16

CHARACTERS

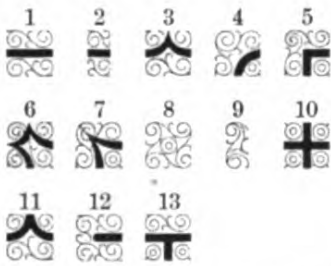

PER FONT
\$5.45

THE
SMALLEST FONT
CONTAINS

35 each of Nos. 4
to 7 and 10 to 13
71 each of Nos. 2
and 9
140 pieces No. 3
280 each of Nos. 1
and 8

V. B. MUNSON, SUCCESSOR TO
GEO. BRUCE'S SON & CO., 13 CHAMBERS STREET, NEW YORK.

COMBINATION BORDER NO. 21

COMBINATION BORDER NO. 21

1900

NOSNIUM

CHARACTERS

1 2 3 4 5
6 7 8
9 10

PER FONT
\$4.50

TYPE

THE
SMALLEST
FONT
CONTAINS

280 pieces of
No. 1

70 pieces of
8 and 9

140 each of
Nos. 2 to 7
and 10

also Quads

V. B. MUNSON, SUCCESSOR TO
GEO. BRUCE'S SON & CO., 13 CHAMBERS STREET, NEW YORK.

COMBINATION BORDER NO. 70

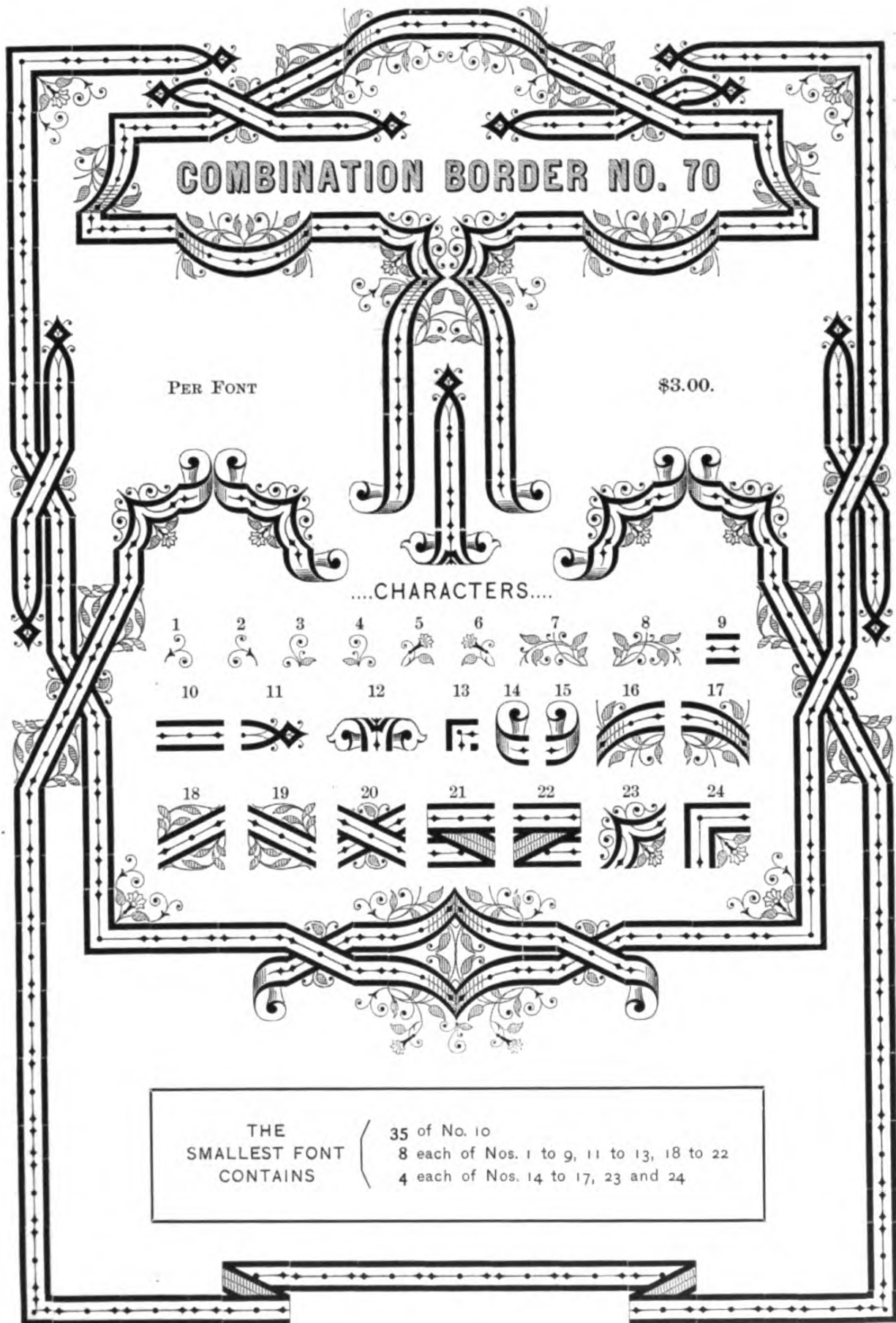

V. B. MUNSON, SUCCESSOR TO
 GEO. BRUCE'S SON & CO., 13 CHAMBERS STREET, NEW YORK.

SIXTY POINT COMBINATION BANDS OR BORDERS

No. 1



No. 2



No. 3

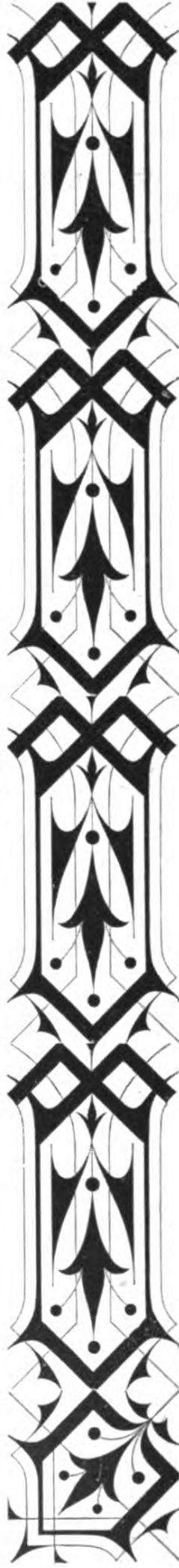

No. 4



PUT UP IN 1 FOOT FONTS. PRICE, \$1.75

SIXTY POINT COMBINATION BANDS OR BORDERS

No. 10.



No. 6.



No. 11.



No. 5.



PUT UP IN 1 FOOT FONTS. PRICE, \$1.75.

SIXTY POINT COMBINATION BANDS OR BORDERS

No. 7.

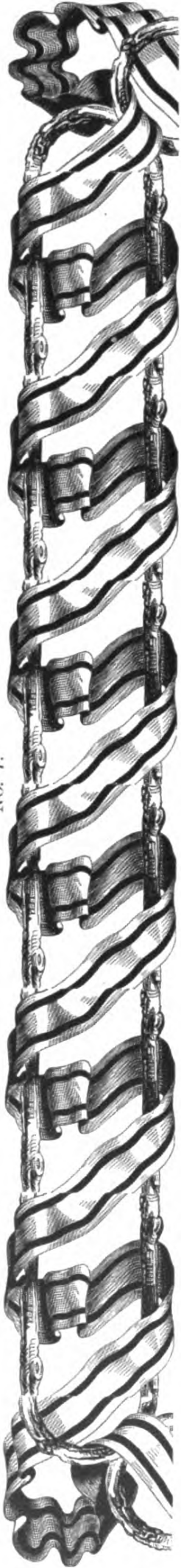

No. 9.

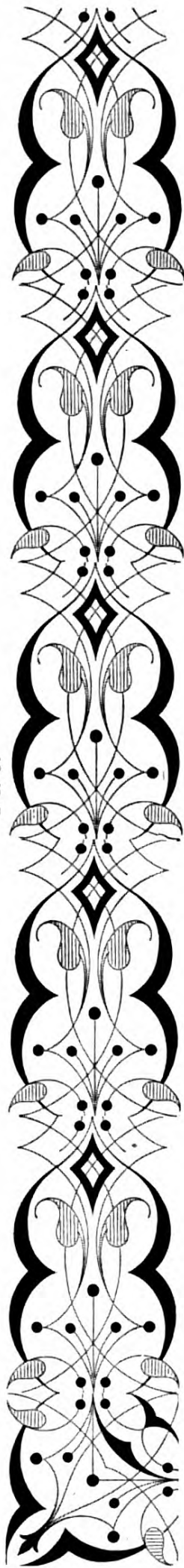

No. 12.



No. 13.

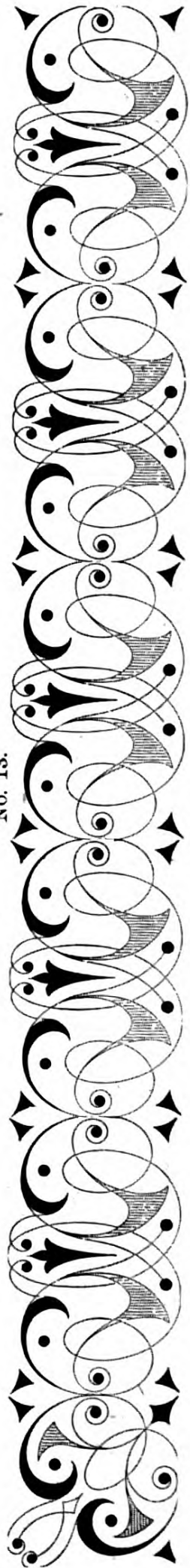

PUT UP IN 1 FOOT FONTS. PRICE, \$1.50

COMBINATION BORDER NO. 16

COMBINATION
BORDER
NO. 16

ELEGANCE

CHARACTERS

1	2	3	4	5
6	7	8	9	10
11	12	13		

PER FONT
\$5.45

THE
SMALLEST FONT
CONTAINS

35 each of Nos. 4
to 7 and 10 to 13

71 each of Nos. 2
and 9

140 pieces No. 3

280 each of Nos. 1
and 8

V. B. MUNSON, SUCCESSOR TO
GEO. BRUCE'S SON & CO., 13 CHAMBERS STREET, NEW YORK.

COMBINATION BORDER NO. 21

COMBINATION BORDER NO. 21

1900

NOSNUM

CHARACTERS

1	2	3	4	5
6	7	8		
9	10			

PER FONT
\$4.50

TYPE

THE SMALLEST FONT CONTAINS

- 280 pieces of No. 1
- 70 pieces of 8 and 9
- 140 each of Nos. 2 to 7 and 10
- also Quads

V. B. MUNSON, SUCCESSOR TO
GEO. BRUCE'S SON & CO., 13 CHAMBERS STREET, NEW YORK.

COMBINATION BORDER NO. 70

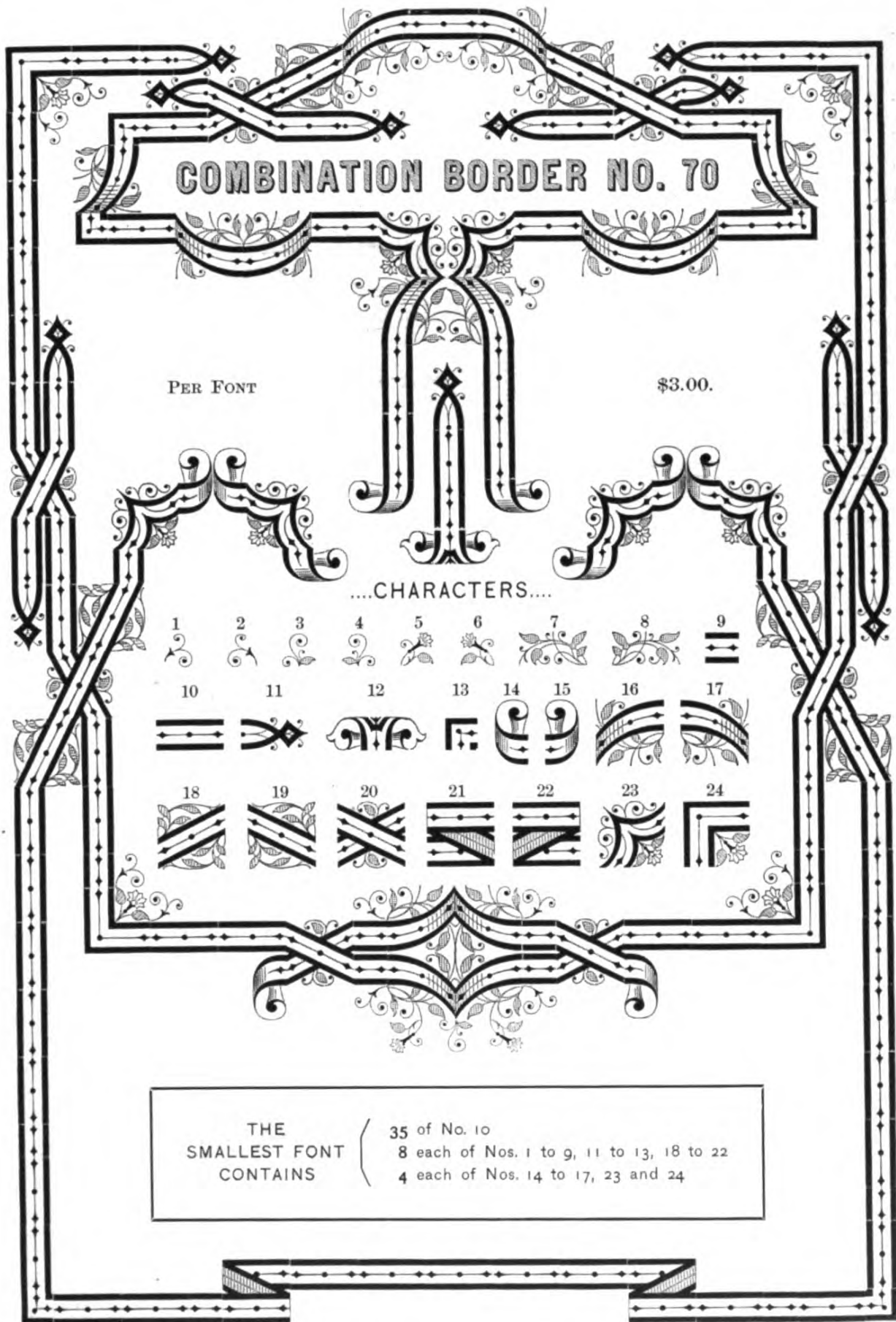

THE
SMALLEST FONT
CONTAINS

{	35 of No. 10
	8 each of Nos. 1 to 9, 11 to 13, 18 to 22
	4 each of Nos. 14 to 17, 23 and 24

V. B. MUNSON, SUCCESSOR TO
GEO. BRUCE'S SON & CO., 13 CHAMBERS STREET, NEW YORK.

BRASS RULE

No. 500	5 CENTS PER FOOT	1 POINT
" 501	7½ CENTS PER FOOT	1½ "
" 502	10 CENTS PER FOOT	2 "
" 503	15 CENTS PER FOOT	3 "
" 504	20 CENTS PER FOOT	4 "
" 505	25 CENTS PER FOOT	5 "
" 506	27½ CENTS PER FOOT	5½ "
" 507	30 CENTS PER FOOT	6 "
" 508	35 CENTS PER FOOT	7 "
" 509	40 CENTS PER FOOT	8 "
" 510	45 CENTS PER FOOT	9 "
" 511	50 CENTS PER FOOT	10 "
" 512	55 CENTS PER FOOT	11 "
" 513	60 CENTS PER FOOT	12 "
" 514	10 CENTS PER FOOT	2 "
" 515	15 CENTS PER FOOT	3 "
" 516	20 CENTS PER FOOT	4 "
" 517	20 CENTS PER FOOT	4 "
" 518	25 CENTS PER FOOT	5 "

All these Rules are sold in two-foot strips, or can be supplied in
Labor-saving Fonts. See pages 386 and 387

V. B. MUNSON, SUCCESSOR TO
GEO. BRUCE'S SON & CO., 13 CHAMBERS STREET, NEW YORK.

BRASS RULE

No. 519	30 CENTS PER FOOT	6 POINT
" 520	40 CENTS PER FOOT	8 "
" 521	50 CENTS PER FOOT	10 "
" 522	60 CENTS PER FOOT	12 "
" 523	15 CENTS PER FOOT	3 "
" 524	15 CENTS PER FOOT	3 "
" 525	20 CENTS PER FOOT	4 "
" 526	20 CENTS PER FOOT	4 "
" 527	25 CENTS PER FOOT	5 "
" 528	25 CENTS PER FOOT	5 "
" 529	30 CENTS PER FOOT	6 "
" 530	40 CENTS PER FOOT	8 "
" 531	50 CENTS PER FOOT	10 "
" 532	60 CENTS PER FOOT	12 "
" 533	15 CENTS PER FOOT	3 "
" 534	20 CENTS PER FOOT	4 "
" 535	25 CENTS PER FOOT	5 "
" 536	27½ CENTS PER FOOT	5½ "

All these Rules are sold in two-foot strips, or can be supplied in
Labor-saving Fonts. See pages 386 and 387

V. B. MUNSON, SUCCESSOR TO
GEO. BRUCE'S SON & CO., 13 CHAMBERS STREET, NEW YORK.

BRASS RULE

No. 537	30 CENTS PER FOOT	6 POINT
" 538	40 CENTS PER FOOT	8 "
" 539	40 CENTS PER FOOT	8 "
" 540	45 CENTS PER FOOT	9 "
" 541	50 CENTS PER FOOT	10 "
" 542	60 CENTS PER FOOT	12 "
" 543	20 CENTS PER FOOT	4 "
" 544	25 CENTS PER FOOT	5 "
" 545	30 CENTS PER FOOT	6 "
" 546	40 CENTS PER FOOT	8 "
" 547	50 CENTS PER FOOT	10 "
" 548	60 CENTS PER FOOT	12 "
" 549	20 CENTS PER FOOT	4 "
" 550	25 CENTS PER FOOT	5 "
" 551	30 CENTS PER FOOT	6 "
" 552	40 CENTS PER FOOT	8 "
" 553	50 CENTS PER FOOT	10 "
" 554	60 CENTS PER FOOT	12 "

All these Rules are sold in two-foot strips, or can be supplied in
Labor-saving Fonts. See pages 386 and 387

V. B. MUNSON, SUCCESSOR TO
GEO. BRUCE'S SON & CO., 13 CHAMBERS STREET, NEW YORK.

BRASS RULE

No. 555	20 CENTS PER FOOT	4 POINT
" 556	25 CENTS PER FOOT	5 "
" 557	30 CENTS PER FOOT	6 "
" 558	40 CENTS PER FOOT	8 "
" 559	50 CENTS PER FOOT	10 "
" 560	60 CENTS PER FOOT	12 "

The above Rules are sold in two-foot strips, or can be supplied in Labor-saving Fonts. See pages 386 and 387

" 561	10 CENTS PER FOOT	2 "
" 562	10 CENTS PER FOOT	2 "
" 563	10 CENTS PER FOOT	2 "
" 564	10 CENTS PER FOOT	2 "
" 565	15 CENTS PER FOOT	3 "
" 566	20 CENTS PER FOOT	4 "
" 567	25 CENTS PER FOOT	5 "
" 568	30 CENTS PER FOOT	6 "
" 569	10 CENTS PER FOOT	2 "
" 570	15 CENTS PER FOOT	3 "
" 571	20 CENTS PER FOOT	4 "
" 572	25 CENTS PER FOOT	5 "
" 573	10 CENTS PER FOOT	2 "
" 574	15 CENTS PER FOOT	3 "
" 575	20 CENTS PER FOOT	4 "
" 576	25 CENTS PER FOOT	5 "

V. B. MUNSON, SUCCESSOR TO
GEO. BRUCE'S SON & CO., 13 CHAMBERS STREET, NEW YORK.

BRASS RULE

No. 577	10 CENTS PER FOOT	2 POINT
" 578	10 CENTS PER FOOT	2 "
" 579	10 CENTS PER FOOT	2 "
" 580	15 CENTS PER FOOT	3 "
" 581	10 CENTS PER FOOT	2 "
" 582	15 CENTS PER FOOT	3 "
" 583	15 CENTS PER FOOT	3 "
" 584	20 CENTS PER FOOT	4 "
" 585	15 CENTS PER FOOT	3 "
" 586	25 CENTS PER FOOT	5 "
" 587	15 CENTS PER FOOT	3 "
" 588	25 CENTS PER FOOT	5 "
" 589	27½ CENTS PER FOOT	5½ "
" 590	30 CENTS PER FOOT	6 "
" 591	30 CENTS PER FOOT	6 "
" 592	25 CENTS PER FOOT	5 "
" 593	40 CENTS PER FOOT	8 "
" 594	15 CENTS PER FOOT	3 "
" 595	25 CENTS PER FOOT	5 "
" 596	30 CENTS PER FOOT	6 "
" 597	30 CENTS PER FOOT	6 "
" 598	25 CENTS PER FOOT	5 "

V. B. MUNSON, SUCCESSOR TO
GEO. BRUCE'S SON & CO., 13 CHAMBERS STREET, NEW YORK.

BRASS RULE

No. 599	40 CENTS PER FOOT	10 POINT
" 600	50 CENTS PER FOOT	10 "
" 601	30 CENTS PER FOOT	6 "
" 602	25 CENTS PER FOOT	5 "
" 603	40 CENTS PER FOOT	8 "
" 604	25 CENTS PER FOOT	5 "
" 605	40 CENTS PER FOOT	8 "
" 606	25 CENTS PER FOOT	5 "
" 607	50 CENTS PER FOOT	10 "
" 608	40 CENTS PER FOOT	8 "
" 609	50 CENTS PER FOOT	10 "
" 610	25 CENTS PER FOOT	5 "
" 611	25 CENTS PER FOOT	5 "
" 612	25 CENTS PER FOOT	5 "
" 613	30 CENTS PER FOOT	6 "
" 614	30 CENTS PER FOOT	6 "
" 615	40 CENTS PER FOOT	8 "
" 616	40 CENTS PER FOOT	8 "
" 617	30 CENTS PER FOOT	6 "











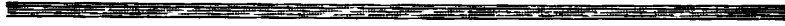
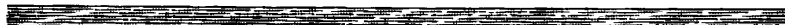

V. B. MUNSON, SUCCESSOR TO
GEO. BRUCE'S SON & CO., 13 CHAMBERS STREET, NEW YORK.

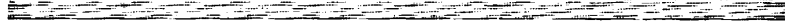
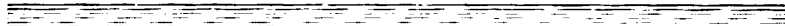
BRASS RULE

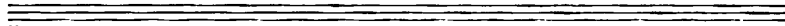
No. 618	30 CENTS PER FOOT	6 POINT
" 619	30 CENTS PER FOOT	6 "
" 620	40 CENTS PER FOOT	8 "
" 621	30 CENTS PER FOOT	6 "
" 622	40 CENTS PER FOOT	8 "
" 623	10 CENTS PER FOOT	2 "
" 624	20 CENTS PER FOOT	4 "
" 625	10 CENTS PER FOOT	2 "
" 626	15 CENTS PER FOOT	3 "
" 627	20 CENTS PER FOOT	4 "
" 628	20 CENTS PER FOOT	4 "
" 629	25 CENTS PER FOOT	5 "
" 630	30 CENTS PER FOOT	4 "
" 631	25 CENTS PER FOOT	5 "
" 632	30 CENTS PER FOOT	6 "
" 633	30 CENTS PER FOOT	6 "
" 634	30 CENTS PER FOOT	6 "
" 635	30 CENTS PER FOOT	6 "
" 636	30 CENTS PER FOOT	6 "
" 637	30 CENTS PER FOOT	6 "
" 638	30 CENTS PER FOOT	6 "

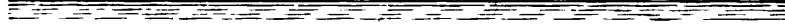
V. B. MUNSON, SUCCESSOR TO
GEO. BRUCE'S SON & CO., 13 CHAMBERS STREET, NEW YORK.

BRASS RULE

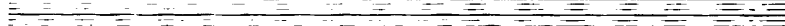
No. 639	20 CENTS PER FOOT 	4 POINT
" 640	30 CENTS PER FOOT 	6 "
" 641	40 CENTS PER FOOT 	8 "
" 642	40 CENTS PER FOOT 	10 "
" 643	60 CENTS PER FOOT 	12 "
" 644	60 CENTS PER FOOT 	12 "
" 645	60 CENTS PER FOOT 	12 "
" 646	60 CENTS PER FOOT 	12 "
" 647	60 CENTS PER FOOT 	12 "
" 648	60 CENTS PER FOOT 	12 "
" 649	60 CENTS PER FOOT 	12 "
" 650	60 CENTS PER FOOT 	12 "
" 651	60 CENTS PER FOOT 	12 "
" 652	60 CENTS PER FOOT 	12 "
" 653	60 CENTS PER FOOT 	12 "
" 654	60 CENTS PER FOOT 	12 "
" 655	60 CENTS PER FOOT 	12 "

V. B. MUNSON, SUCCESSOR TO
GEO. BRUCE'S SON & CO., 13 CHAMBERS STREET, NEW YORK.

LABOR-SAVING RULE

DOTTED

Smallest Font weighs 2 lb. 14 oz.

No. 561—2-POINT.

Per lb., \$1.75.

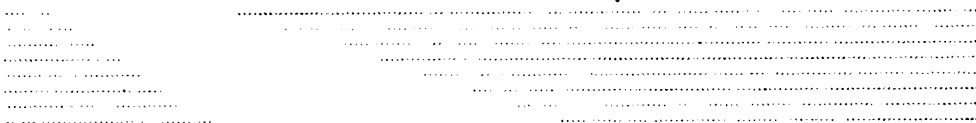

Smallest Font weighs 2 lb. 14 oz.

No. 564—2-POINT.

Per lb., \$1.75.

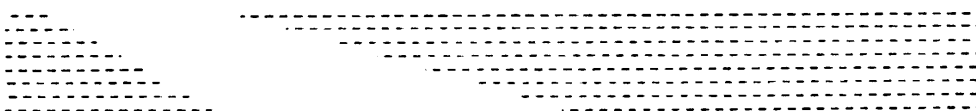

FONT ONE-HALF SIZE OF SCHEME SHOWN ON PAGE 387.

SINGLE

Smallest Font weighs 5 lb. 12 oz.

No. 502—2-POINT.

Per lb., \$1.75.

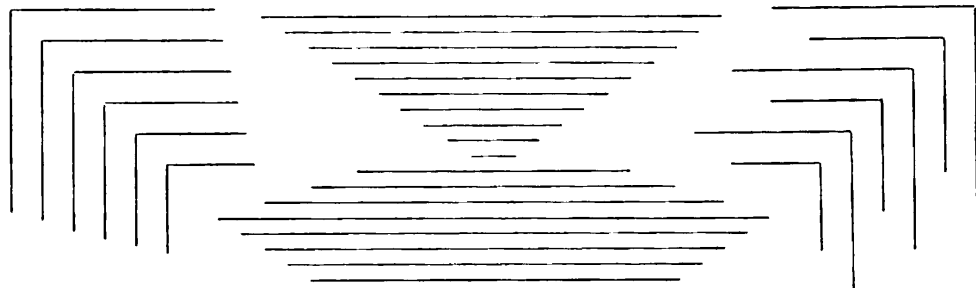

FOR SCHEME OF SINGLE RULE SEE PAGE 387.

PARALLEL

Smallest Font weighs 8 lb. 12 oz.

No. 515—3-POINT.

Per lb., \$1.60.

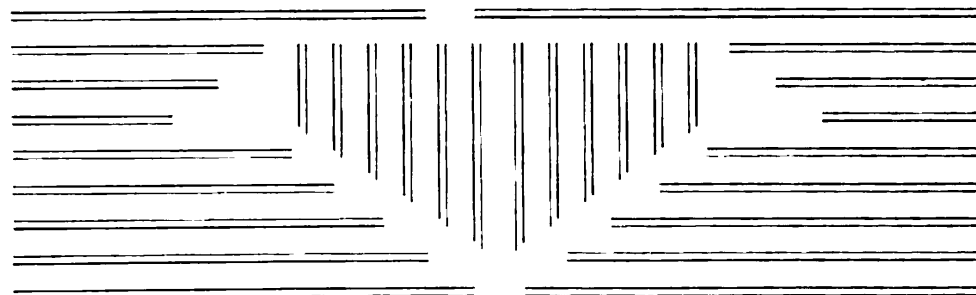

FOR SCHEME OF PARALLEL RULE SEE PAGE 387.

V. B. MUNSON, SUCCESSOR TO
GEO. BRUCE'S SON & CO., 13 CHAMBERS STREET, NEW YORK.

LABOR-SAVING RULE

RIGHT MITRES

2	2
2½	2½
3	3
4	4
4½	4½

ON THIS PAGE is shown one piece of each length contained in an ordinary font of Labor-Saving Rule, the 428 pieces composing font being apportioned as follows, the numbers denoting 12-point ems:

12	each	of	No.	1	to	No.	6
12	"	"	"	1½	"	"	6½
10	"	"	"	7	"	"	16
6	"	"	"	17	"	"	26
4	"	"	"	27	"	"	36
8 right mitres, from 2½ to 4½							
8 left " " 2½ to 4½							

The Rule shown is 3-point Double.
A font weighs 8 lb. 10 oz. ... Price,
\$1.60 per lb.

LEFT MITRES

2	2
2½	2½
3	3
4	4
4½	4½

V. B. MUNSON, SUCCESSOR TO
GEO. BRUCE'S SON & CO. 13 CHAMBERS STREET, NEW YORK.

NEW STYLE BEVELED BRASS RULES

No.	1	10 CENTS PER FOOT	2 POINT
"	2	10 CENTS PER FOOT	2 "
"	3	15 CENTS PER FOOT	3 "
"	4	15 CENTS PER FOOT	3 "
"	5	15 CENTS PER FOOT	3 "
"	6	20 CENTS PER FOOT	4 "
"	7	20 CENTS PER FOOT	4 "
"	8	20 CENTS PER FOOT	4 "
"	9	20 CENTS PER FOOT	4 "
"	10	25 CENTS PER FOOT	5 "
"	11	25 CENTS PER FOOT	5 "
"	12	25 CENTS PER FOOT	5 "
"	13	25 CENTS PER FOOT	5 "
"	14	25 CENTS PER FOOT	5 "
"	15	30 CENTS PER FOOT	6 "
"	16	30 CENTS PER FOOT	6 "
"	17	30 CENTS PER FOOT	6 "
"	18	30 CENTS PER FOOT	6 "
"	19	30 CENTS PER FOOT	6 "
"	20	30 CENTS PER FOOT	6 "

THESE BORDER RULES are all cut with the bevel on one side only, and are used without mitres, insuring better joints with less trouble. Simply reverse the head and foot rules and the joints are complete..... All these Rules are sold in two-foot strips, or can be supplied in Labor-saving Fonts, as shown on Page 389.

V. B. MUNSON, SUCCESSOR TO
GEO. BRUCE'S SON & CO., 13 CHAMBERS STREET, NEW YORK.

BEVELED RULE

IN
LABOR-SAVING
FONTS

No. 1—2-POINT

No. 2—2-POINT

No. 3—3-POINT

No. 4—3-POINT

No. 5—3-POINT

No. 6—4-POINT

No. 7—4-POINT

No. 8—4-POINT

No. 9—4-POINT

No. 10—5-POINT

No. 11—5-POINT

No. 12—5-POINT

No. 13—5-POINT

No. 14—5-POINT

No. 15—6-POINT

No. 16—6-POINT

No. 17—6-POINT

No. 18—6-POINT

No. 19—6-POINT

No. 20—6-POINT

..PRICES..

PER LB.

2-POINT

\$1.75

3-POINT

4 "

5 "

6 "

\$1.60

THIS LABOR-SAVING RULE WILL BE PUT UP IN FONTS
OF ANY SIZE TO SUIT THE PURCHASER .. NO MITRES

V. B. MUNSON, SUCCESSOR TO
GEO. BRUCE'S SON & CO., 13 CHAMBERS STREET, NEW YORK.

BRASS DASHES

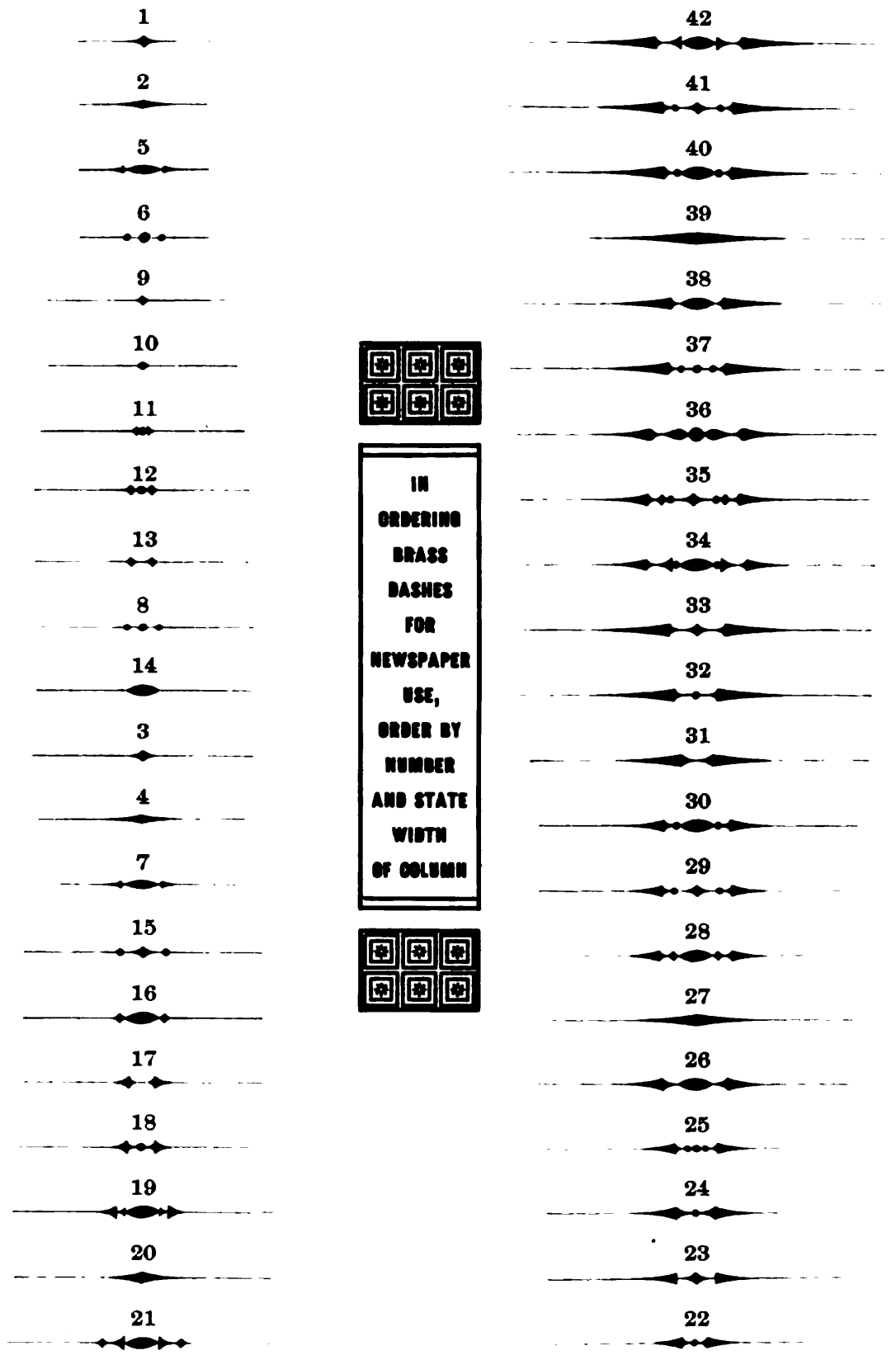

10 CENTS EACH

V. B. MUNSON, SUCCESSOR TO
 GEO. BRUCE'S SON & CO., 13 CHAMBERS STREET, NEW YORK.

BRASS DASHES

15 CENTS EACH

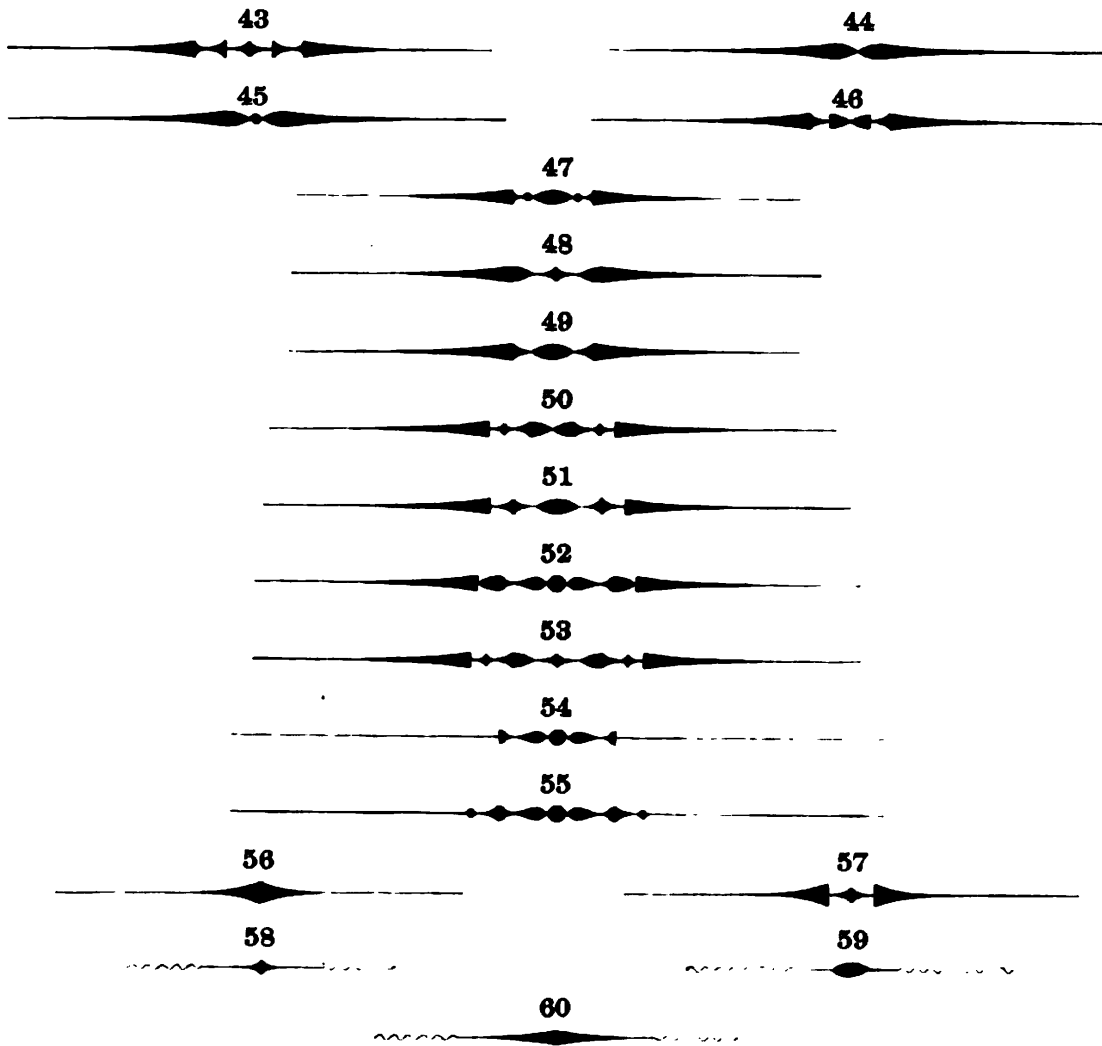

20 CENTS EACH

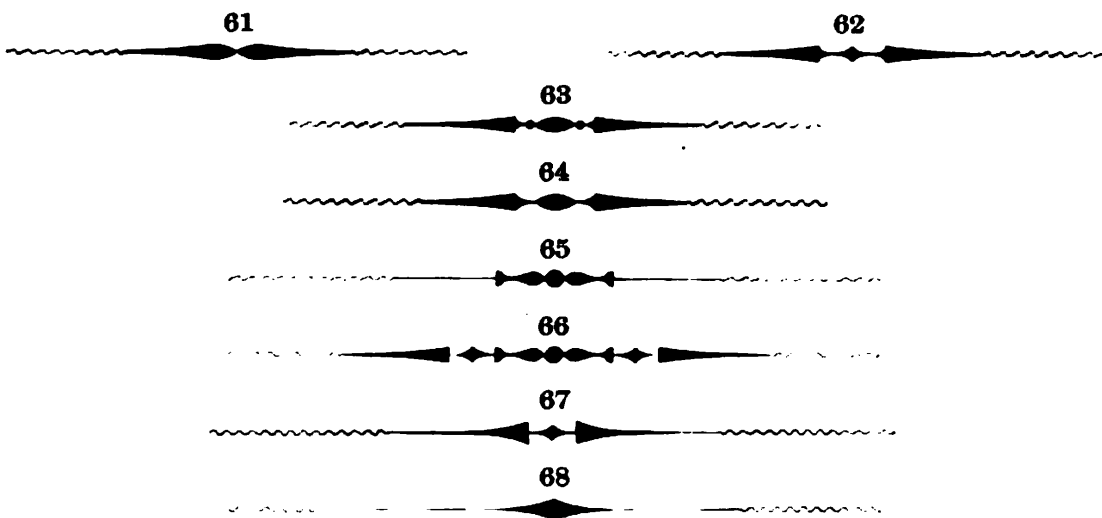

V. B. MUNSON, SUCCESSOR TO
GEO. BRUCE'S SON & CO., 13 CHAMBERS STREET, NEW YORK.

BRASS CIRCLES--SINGLE

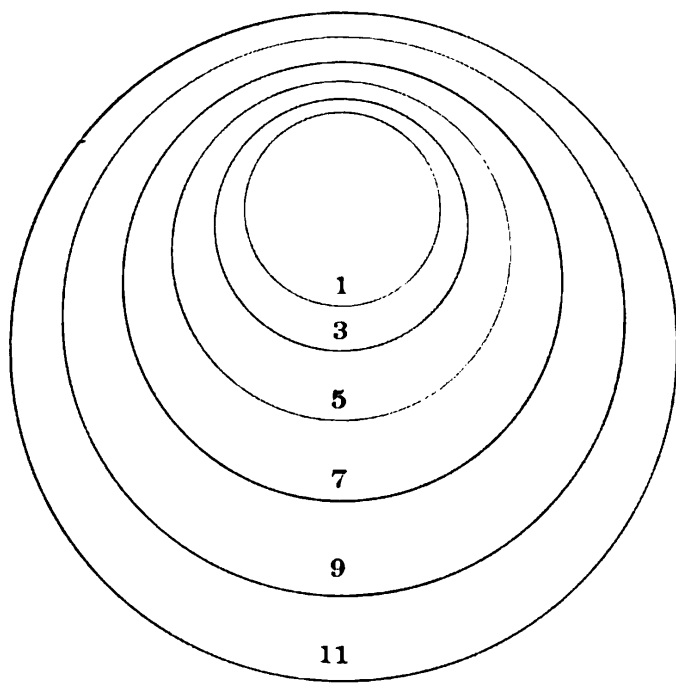

PRICES

No. 1 to No. 5
60c. each

No. 6 to No. 10
75c. each

Nos. 11 and 12
\$1.00 each

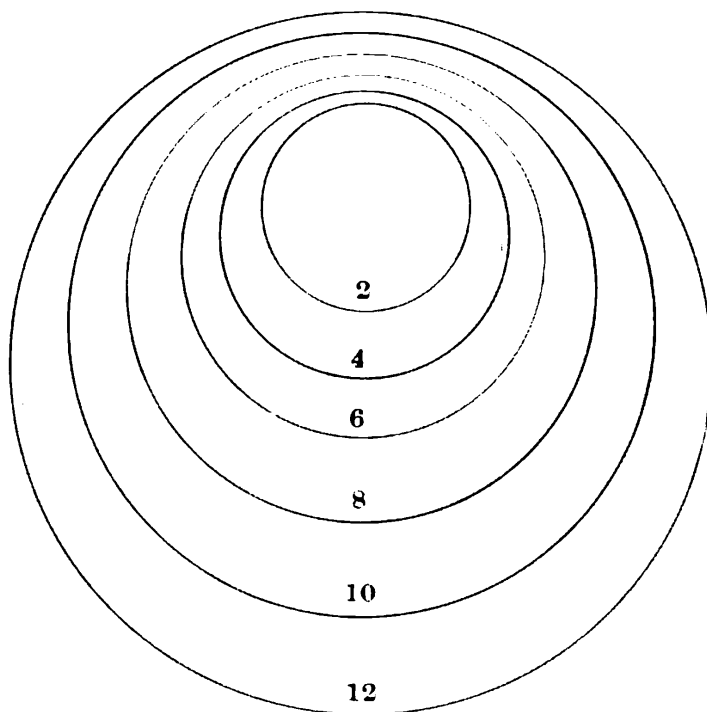

**THE SET OF
TWELVE CIRCLES**

\$8.25

V. B. MUNSON, SUCCESSOR TO
GEO. BRUCE'S SON & CO., 13 CHAMBERS STREET, NEW YORK.

BRASS CIRCLES--DOUBLE

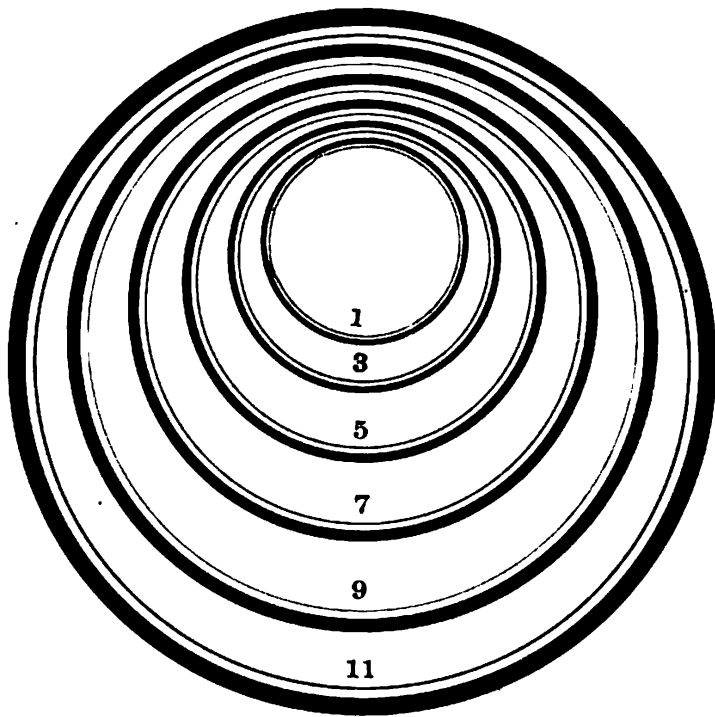

PRICES	
Nos. 1 to 5	\$0.60
EACH	
Nos. 6 to 10	\$0.75
EACH	
Nos. 11 AND 12	\$1.00
EACH	

THE
SET
OF
12
CIRCLES
FOR
\$8.25

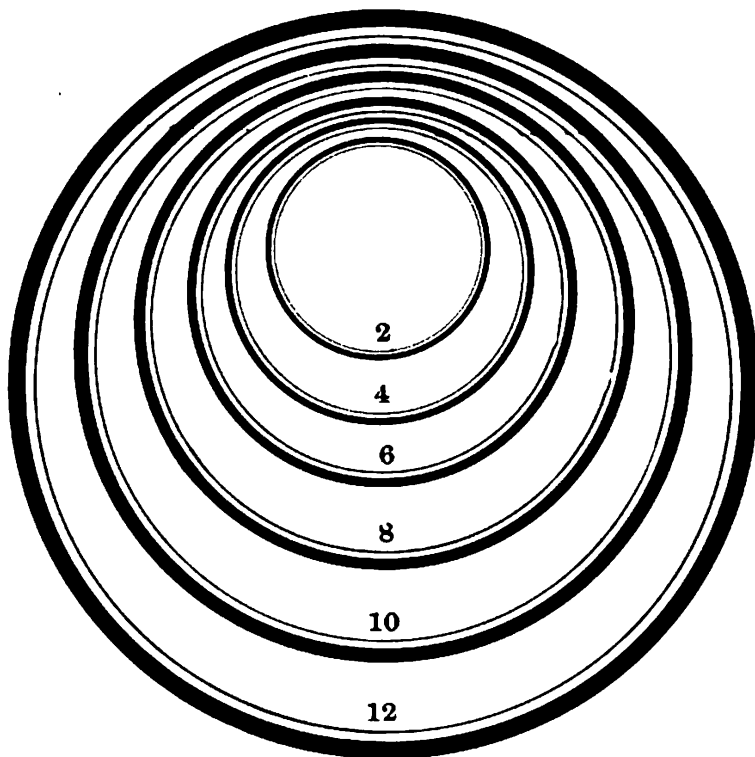

V. B. MUNSON, SUCCESSOR TO
GEO. BRUCE'S SON & CO., 13 CHAMBERS STREET, NEW YORK.

BRASS CIRCLES -- PARALLEL

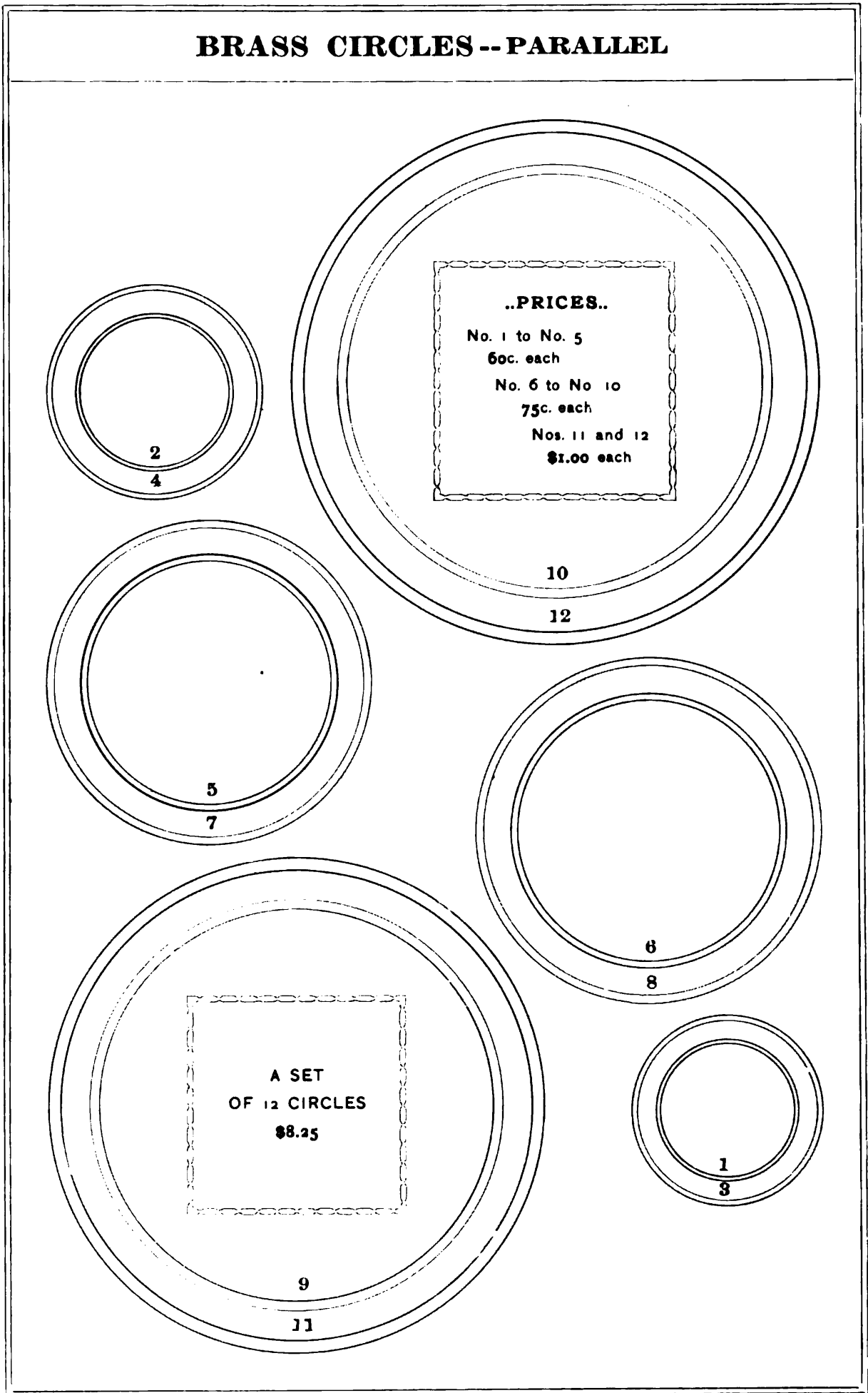

V. B. MUNSON, SUCCESSOR TO
GEO. BRUCE'S SON & CO., 13 CHAMBERS STREET, NEW YORK.

BRASS CIRCLES--TRIPLE

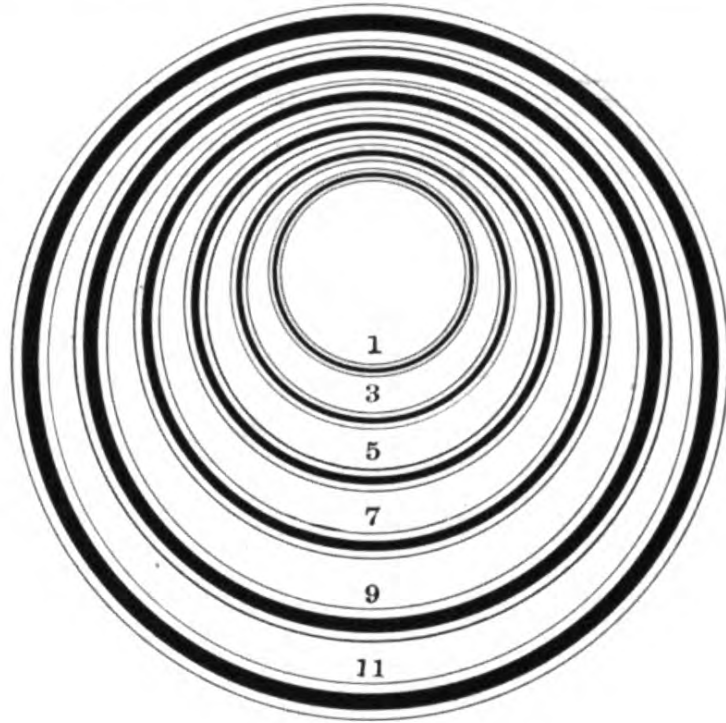

☼	☼	☼	☼
↓	↓	↓	↓
PRICES			
NO. 1 TO NO. 5			
\$0.60 EACH			
NO. 6 TO NO. 10			
\$0.75 EACH			
NOS. 11 AND 12			
\$1.00 EACH			
■			
THE SET OF			
12			
CIRCLES			
FOR \$8.25			
↑	↑	↑	↑
☼	☼	☼	☼

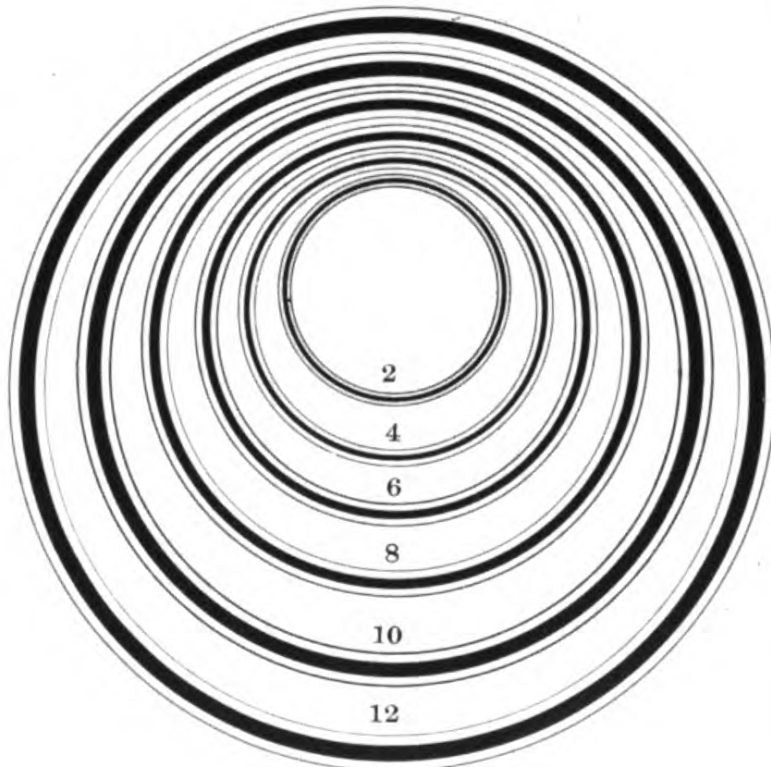

V. B. MUNSON, SUCCESSOR TO
 GEO. BRUCE'S SON & CO., 13 CHAMBERS STREET, NEW YORK.

BRASS ELLIPSES -- SINGLE

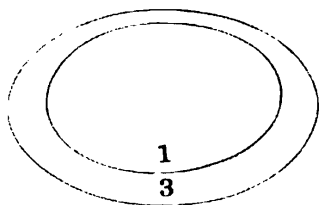
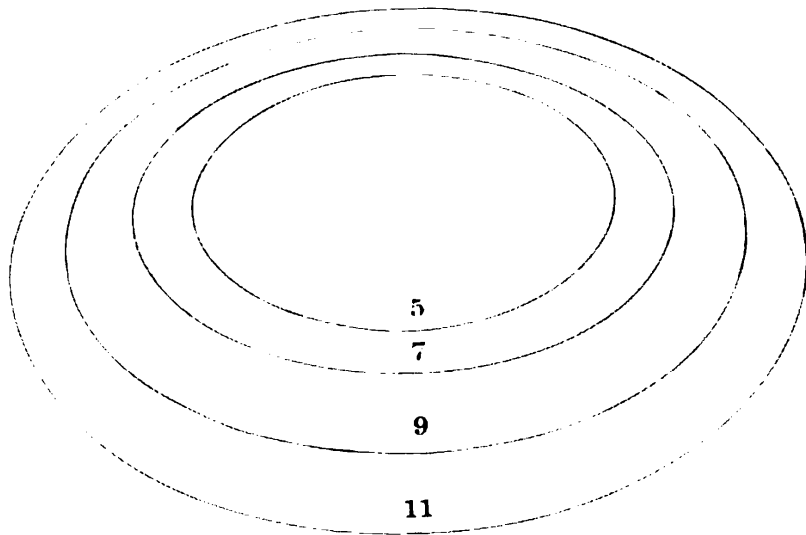

...PRICES...
No. 1 to No. 5,
\$1.00 each
No. 6 to No. 10,
\$1.12 each
Nos. 11 and 12,
\$1.35 each
.....
Set of 12 Ellipses,
\$12.00

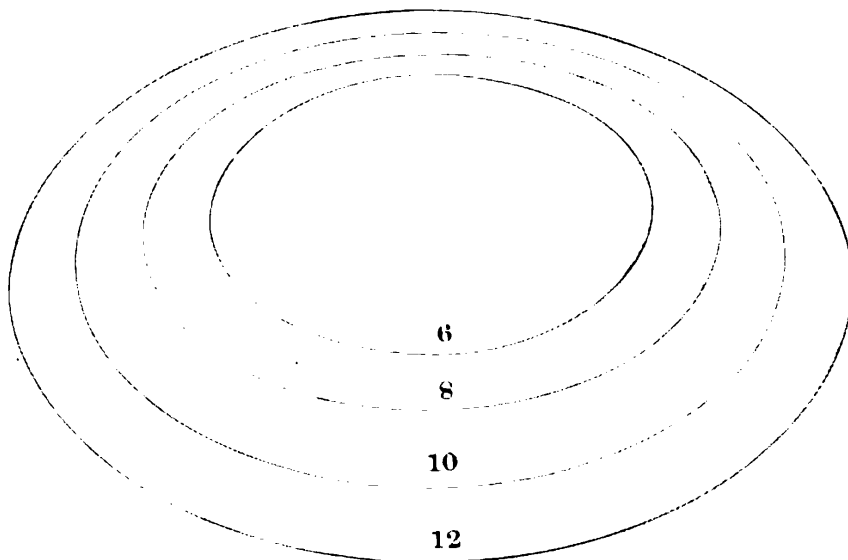
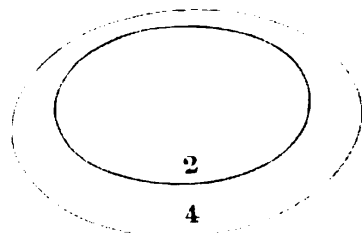

V. B. MUNSON, SUCCESSOR TO
GEO. BRUCE'S SON & CO., 13 CHAMBERS STREET, NEW YORK.

BRASS ELLIPSES--DOUBLE

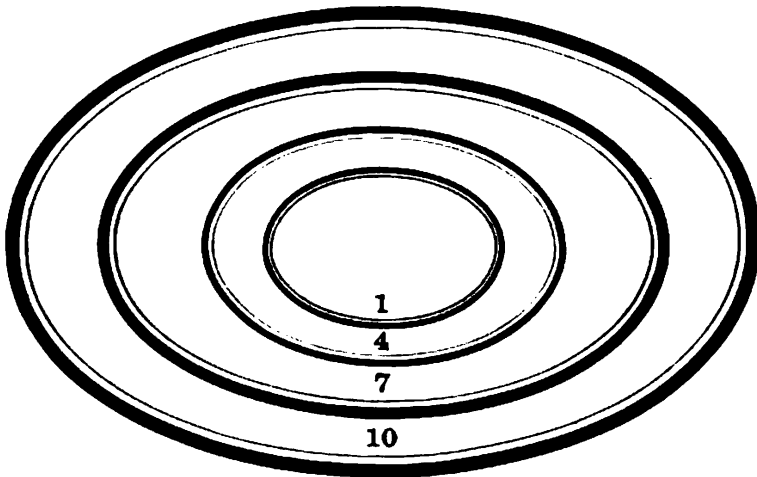

PRICES

NOS. 1 TO 5
\$1.00
EACH

NOS. 6 TO 10
\$1.12
EACH

NOS. 11 AND 12
\$1.35
EACH

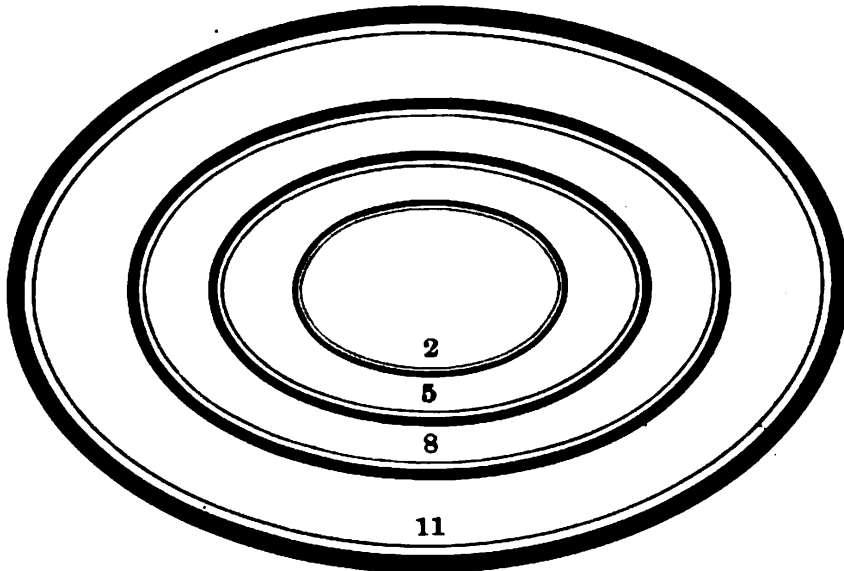

THE SET
OF
12
ELLIPSES
FOR
\$12.00

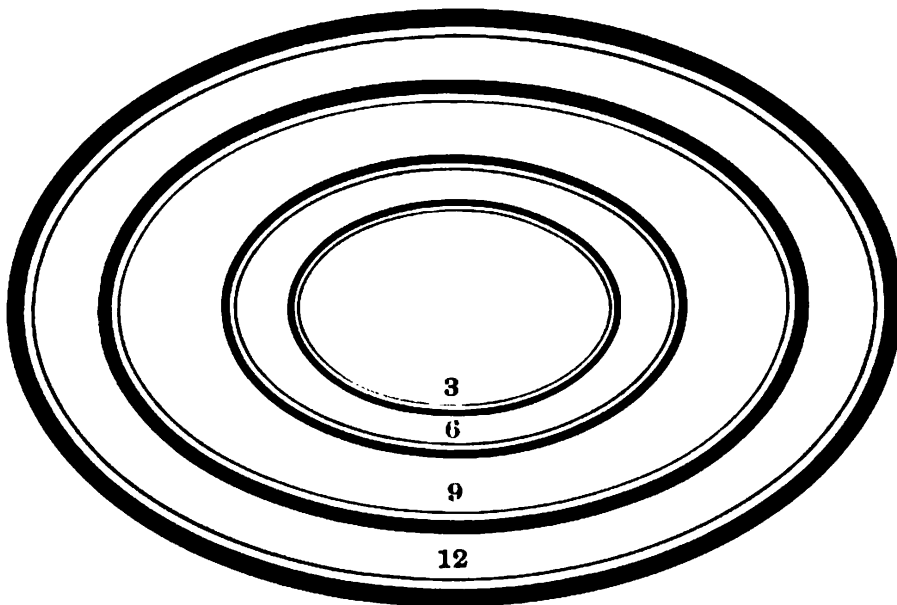

V. B. MUNSON, SUCCESSOR TO
GEO. BRUCE'S SON & CO., 13 CHAMBERS STREET, NEW YORK.

BRASS ELLIPSES--PARALLEL

...PRICES...
No. 1 to No. 5
\$1.00 each
No. 6 to No. 10
\$1.12 each
Nos. 11 and 12
\$1.35 each

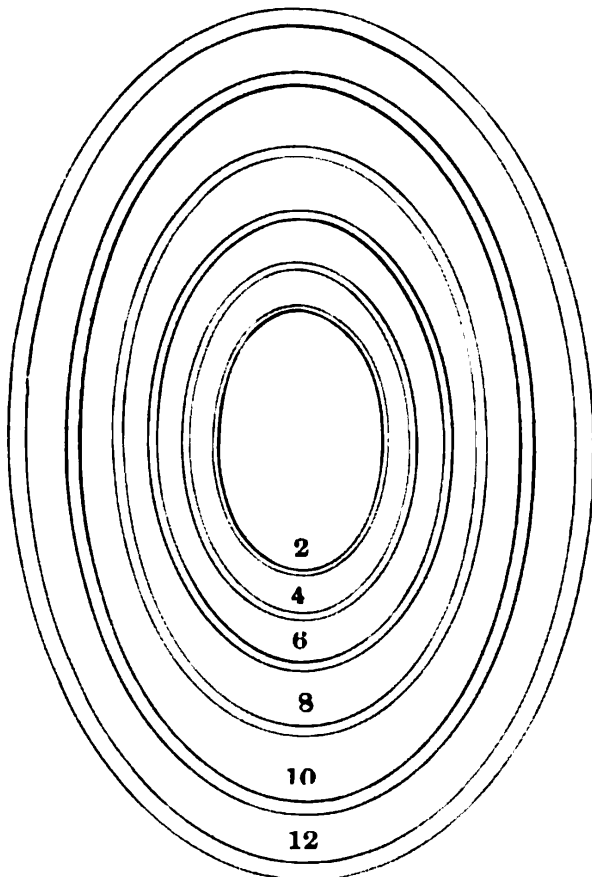
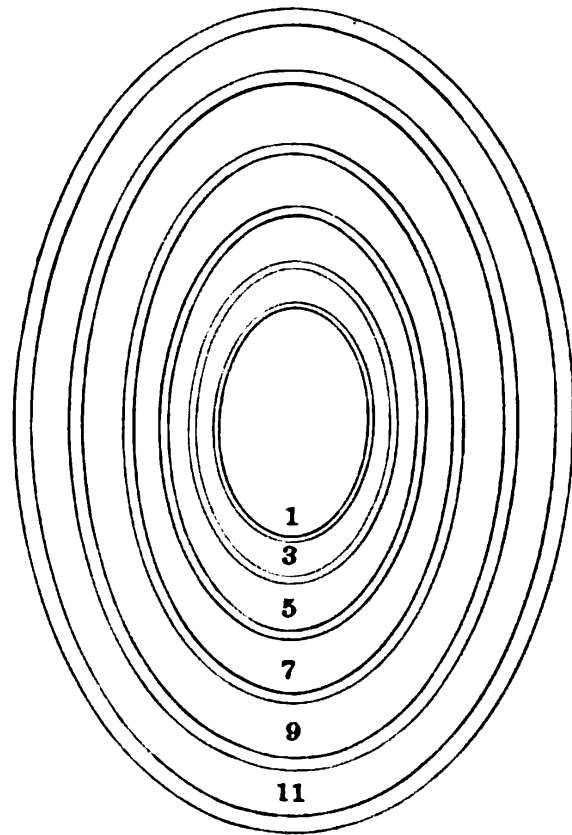

A SET OF
12
ELLIPSES
\$12.00

V. B. MUNSON, SUCCESSOR TO
GEO. BRUCE'S SON & CO., 13 CHAMBERS STREET, NEW YORK.

BRASS ELLIPSES--TRIPLE

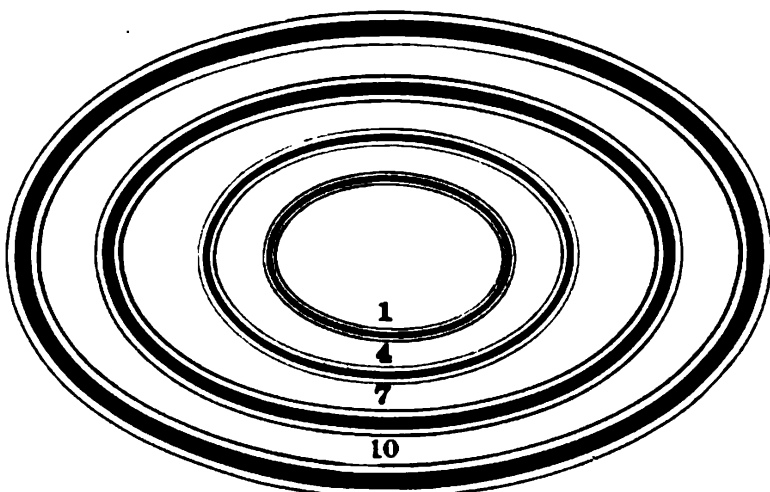

PRICES
NO. 1 TO NO. 5
\$1.00 EACH
NO. 6 TO NO. 10
\$1.12 EACH
NO. 11 AND 12
\$1.35 EACH

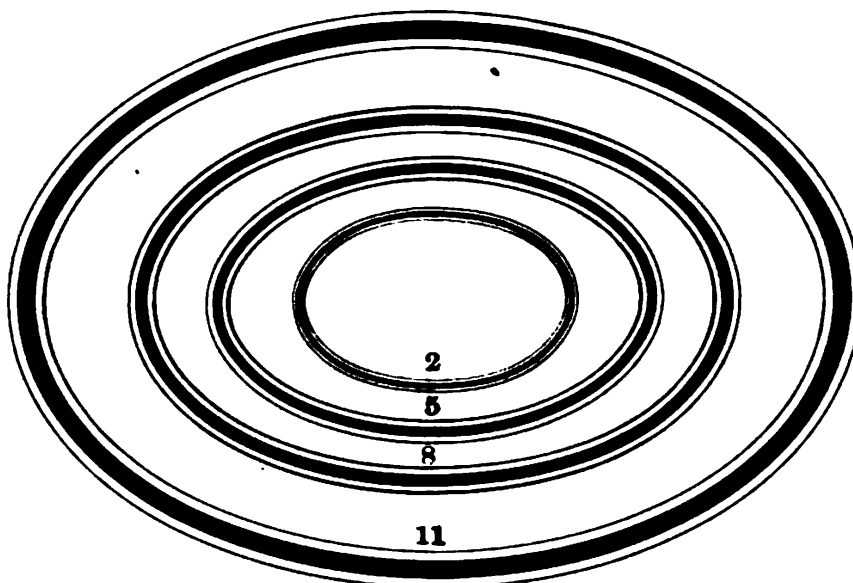

THE SET
OF
12
ELLIPSES
FOR
\$12.00

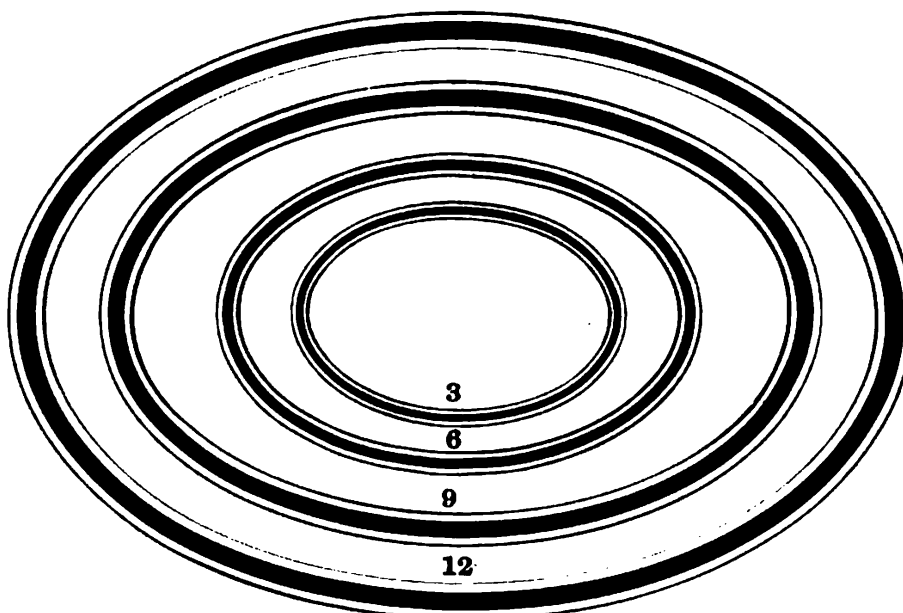

V. B. MUNSON, SUCCESSOR TO
GEO. BRUCE'S SON & CO., 18 CHAMBERS STREET, NEW YORK.

BRASS CIRCLES -- FANCY

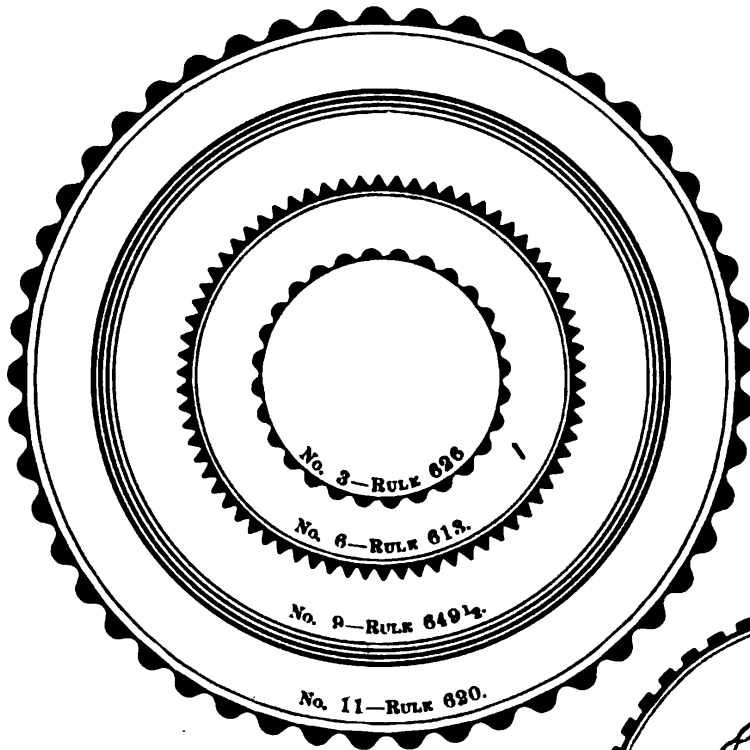

Brass Circles from all patterns of Rule exhibited in this book can be furnished to any of the 12 sizes shown on this page.

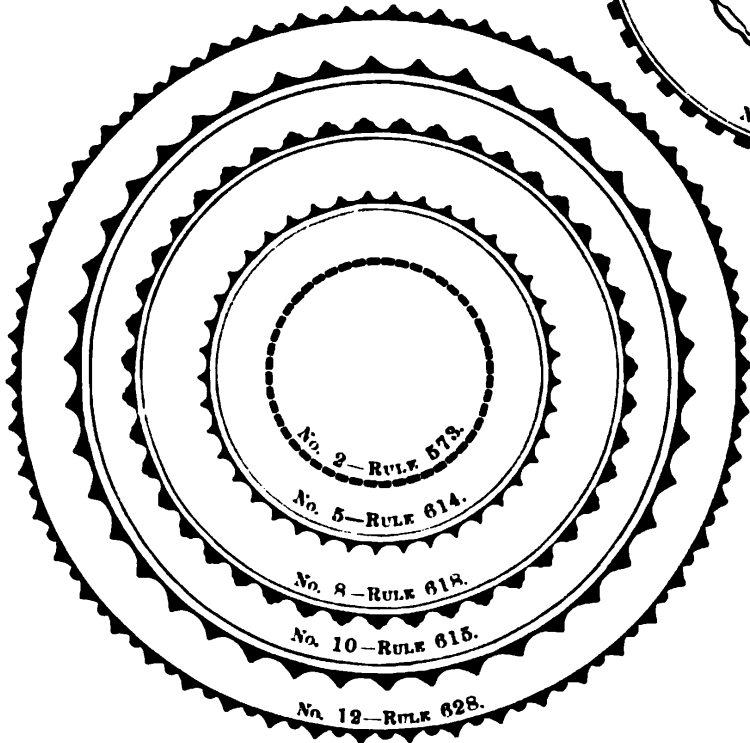
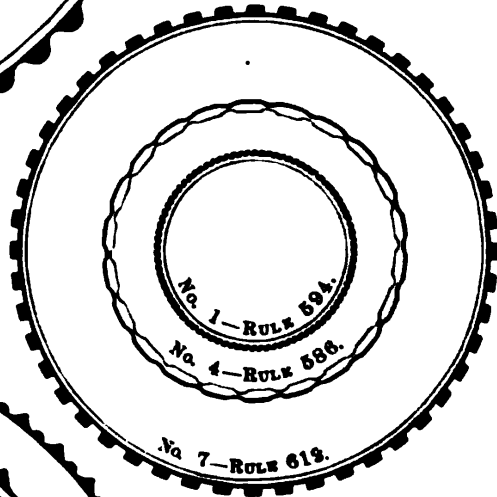

PRICES

**NOS. 1 TO 5,
\$0.75 EACH**

**NOS. 6 TO 10
\$0.90 EACH**

**NOS. 11 AND 12,
\$1.12 EACH**

V. B. MUNSON, SUCCESSOR TO
GEO. BRUCE'S SON & CO., 13 CHAMBERS STREET, NEW YORK.

BRASS ELLIPSES -- FANCY

Brass Ellipses from all patterns of Rule exhibited in this book can be furnished to any of the 12 sizes shown on this page.

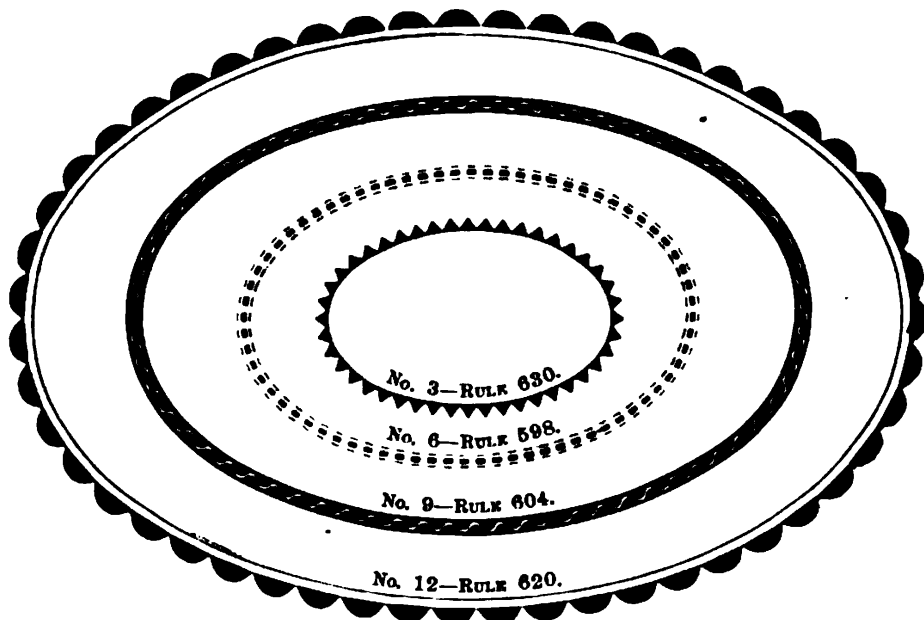
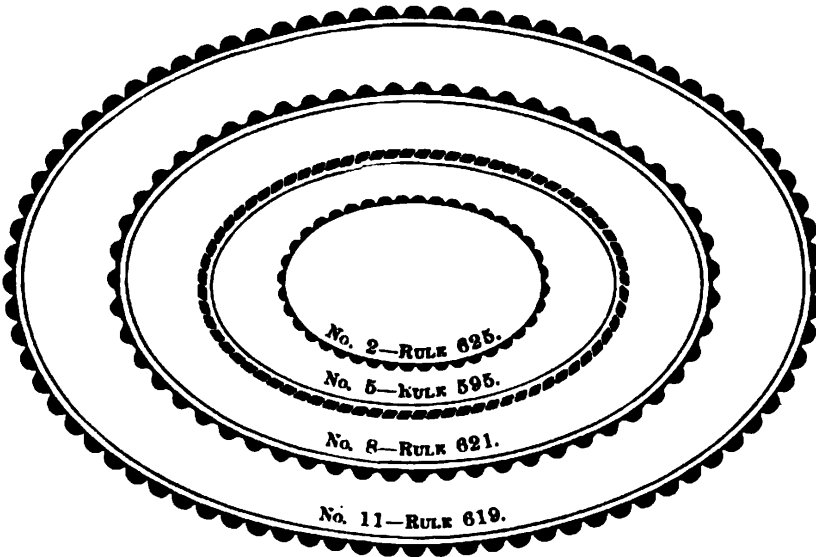
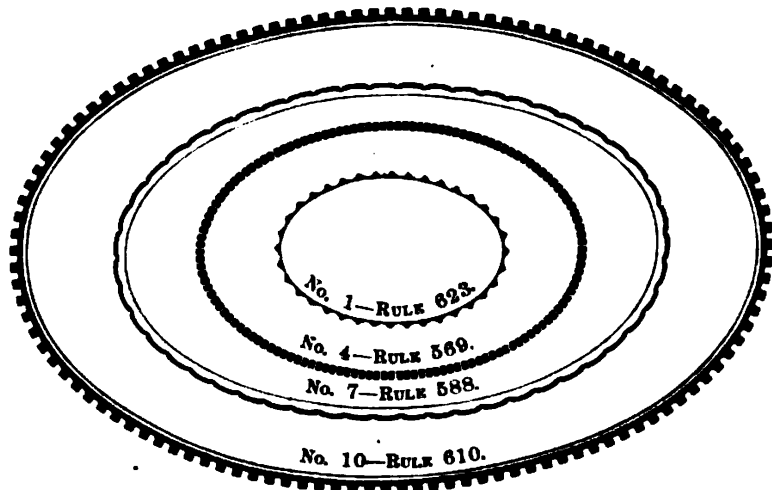

PRICES
 NOS. 1 TO 5,
 \$1.12 EACH
 NOS. 6 TO 10,
 \$1.25 EACH
 NOS. 11 AND 12,
 \$1.50 EACH

V. B. MUNSON, SUCCESSOR TO
 GEO. BRUCE'S SON & CO., 13 CHAMBERS STREET, NEW YORK.

ELECTROTYPE INITIALS

35 CENTS EACH.

SERIES 3.

\$7.00 PER SET.

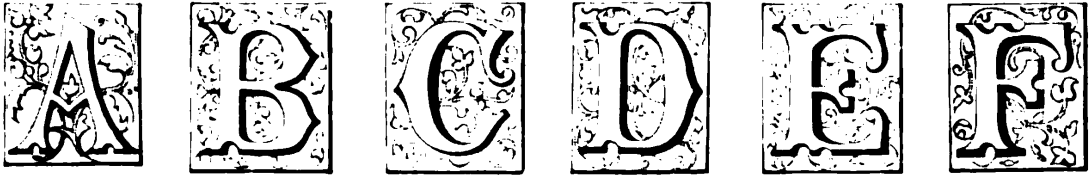

40 CENTS EACH.

SERIES 6.

\$8.00 PER SET.



40 CENTS EACH.

SERIES 7.

\$8.00 PER SET.



25 CENTS EACH.

SERIES 10.

\$5.00 PER SET.



30 CENTS EACH.

SERIES 11.

\$6.00 PER SET.



35 CENTS EACH.

SERIES 12.

\$7.00 PER SET.



V. B. MUNSON, SUCCESSOR TO
GEO. BRUCE'S SON & CO., 13 CHAMBERS STREET, NEW YORK.

ELECTROTYPE INITIALS

60 CENTS EACH.

SERIES 16.

\$12.00 PER SET.



35 CENTS EACH.

SERIES 17.

\$7.00 PER SET.



60 CENTS EACH.

SERIES 20.

\$12.00 PER SET.



50 CENTS EACH.





























SERIES 23.

\$10.00 PER SET.































V. B. MUNSON, SUCCESSOR TO
GEO. BRUCE'S SON & CO., 13 CHAMBERS STREET, NEW YORK.

MALTESE CROSSES

No. 1. 5½-POINT. 	No. 3. 7-POINT. 	No. 5. 9-POINT. 	No. 7. 11-POINT. 	No. 9. 18-POINT. 	No. 11. 30-POINT. 	No. 13. 40-POINT. 
No. 14. 48-POINT. 	No. 12. 36-POINT. 	No. 10. 24-POINT. 	No. 8. 12-POINT. 	No. 6. 10-POINT. 	No. 4. 8-POINT. 	No. 2. 6-POINT. 
20c.	10c.	10c.		5c.	10c.	15c.
No. 1. 5½-POINT. 	No. 3. 7-POINT. 	No. 5. 9-POINT. 	No. 7. 11-POINT. 	No. 9. 18-POINT. 	No. 11. 30-POINT. 	No. 13. 40-POINT. 
No. 14. 48-POINT. 	No. 12. 36-POINT. 	No. 10. 24-POINT. 	No. 8. 12-POINT. 	No. 6. 10-POINT. 	No. 4. 8-POINT. 	No. 2. 6-POINT. 
20c.	10c.	10c.		5c.	10c.	15c.

NOS. 1 TO 5 AND 6 TO 8, IN SETS OF 4 EACH, 15c. PER SET.

STARS

No. 1. 5½-POINT. 	No. 3. 7-POINT. 	No. 5. 9-POINT. 	No. 7. 11-POINT. 	No. 9. 18-POINT. 	No. 11. 30-POINT. 	No. 13. 40-POINT. 
No. 14. 48-POINT. 	No. 12. 36-POINT. 	No. 10. 24-POINT. 	No. 8. 12-POINT. 	No. 6. 10-POINT. 	No. 4. 8-POINT. 	No. 2. 6-POINT. 
20c.	10c.	10c.		5c.	10c.	15c.
No. 1. 5½-POINT. 	No. 3. 7-POINT. 	No. 5. 9-POINT. 	No. 7. 11-POINT. 	No. 9. 18-POINT. 	No. 11. 30-POINT. 	No. 13. 40-POINT. 
No. 14. 48-POINT. 	No. 12. 36-POINT. 	No. 10. 24-POINT. 	No. 8. 12-POINT. 	No. 6. 10-POINT. 	No. 4. 8-POINT. 	No. 2. 6-POINT. 
20c.	10c.	10c.		5c.	10c.	15c.

NOS. 1 TO 5 AND 6 TO 8, IN SETS OF 4, 15c. PER SET.

V. B. MUNSON, SUCCESSOR TO
GEO. BRUCE'S SON & CO., 13 CHAMBERS STREET, NEW YORK.

CHEQUE BLANKS

3300—30c.



3301—30c.



3304—30c.



3305—30c.



3308—30c.



3309—30c.



3312—30c.



3313—30c.



3320—30c.



3321—30c.



3336—35c.



3337—35c.



3344—35c.



3345—35c.

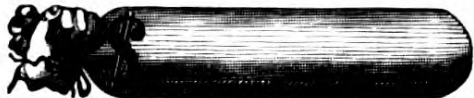

3348—35c.



3349—35c.



3360—35c.



3361—35c.



3368—40c.

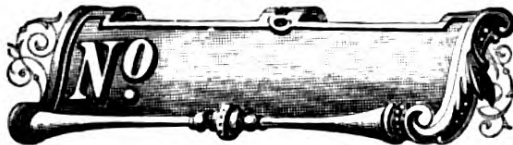

3369—40c.

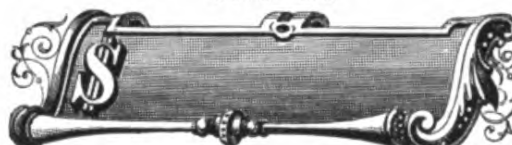

3372—40c.

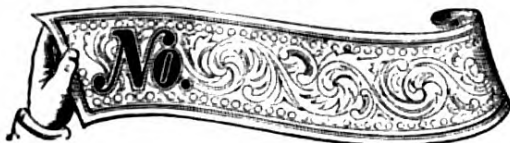

3373—40c.



V. B. MUNSON, SUCCESSOR TO
GEO. BRUCE'S SON & CO., 13 CHAMBERS STREET, NEW YORK.

MISCELLANEOUS CUTS





V. B. MUNSON, SUCCESSOR TO
GEO. BRUCE'S SON & CO., 13 CHAMBERS STREET, NEW YORK.

STATE SEALS

We have Seals of all the States of same size and style as the following.

PRICE—50 CENTS EACH.

2500.  UNITED STATES.	2501.  MAINE.	2502.  NEW HAMPSHIRE.	2503.  VERMONT.	2504.  MASSACHUSETTS.
2505.  RHODE ISLAND.	2506.  CONNECTICUT.	2507.  NEW YORK.	2508.  NEW JERSEY.	2509.  PENNSYLVANIA.
2510.  DELAWARE.	2511.  MARYLAND.	2512.  VIRGINIA.	2513.  WEST VIRGINIA.	2514.  NORTH CAROLINA.
2515.  SOUTH CAROLINA.	2516.  KENTUCKY.	2517.  TENNESSEE.	2518.  GEORGIA.	2519.  FLORIDA.
2520.  ALABAMA.	2521.  MISSISSIPPI.	2522.  LOUISIANA.	2523.  TEXAS.	2524.  OHIO.
2525.  MICHIGAN.	2526.  INDIANA.	2527.  ILLINOIS.	2528.  MISSOURI.	2529.  ARKANSAS.

V. B. MUNSON, SUCCESSOR TO
GEO. BRUCE'S SON & CO., 13 CHAMBERS STREET, NEW YORK.

COATS OF ARMS

We have Coats of Arms of all Countries of same size and style as the following.

PRICE—50 CENTS EACH.



V. B. MUNSON, SUCCESSOR TO
GEO. BRUCE'S SON & CO., 13 CHAMBERS STREET, NEW YORK.

MISCELLANEOUS CUTS

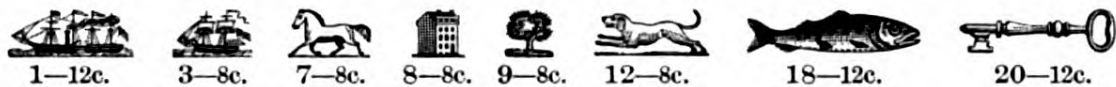

V. B. MUNSON, SUCCESSOR TO
GEO. BRUCE'S SON & CO., 13 CHAMBERS STREET, NEW YORK.

MISCELLANEOUS CUTS



3405—18c.



3411—12c.



3412—18c.



3413—25c.



3414—12c.



3415—18c.



3416—12c.



3417—12c.



3418—12c.



3419—12c.



3422—18c.



3423—25c.



3426—12c.



3427—12c.

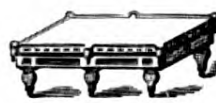

3430—25c.



3450—12c.



3428—18c.

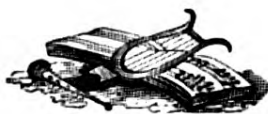

3431—25c.



3432—25c.



3433—18c.



3434—12c.



3436—18c.



3437—18c.



3438—18c.



3439—18c.



3440—18c.



3441—25c.



3435—25c.



3442—18c.



3443—18c.



3445—18c.



3447—18c.



3448—18c.



3451—25c.



3453—18c.



3454—25c.

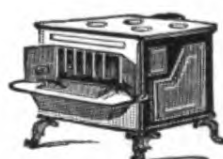

3455—25c.



1873—18c.



3456—18c.



3457—18c.

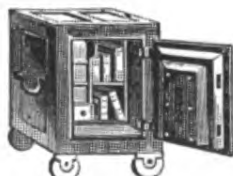

3458—30c.



3460—18c.



3461—35c.

V. B. MUNSON, SUCCESSOR TO
GEO. BRUCE'S SON & CO., 13 CHAMBERS STREET, NEW YORK.

MISCELLANEOUS CUTS

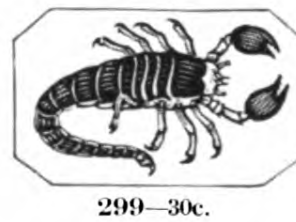
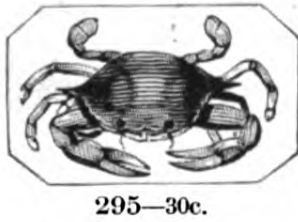
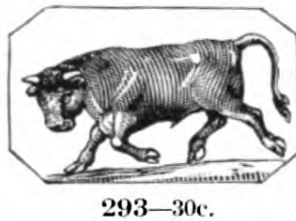
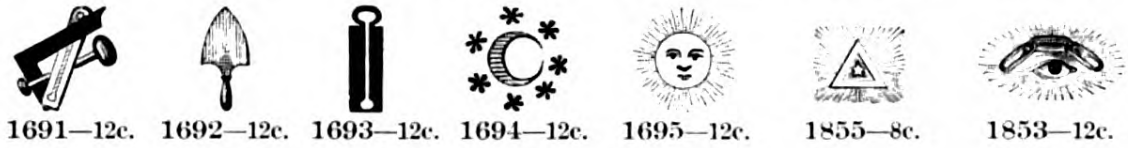

V. B. MUNSON, SUCCESSOR TO
GEO. BRUCE'S SON & CO., 13 CHAMBERS STREET, NEW YORK.

TRADE CUTS

PRICE—FIFTY CENTS EACH



3500. AGRICULTURE.

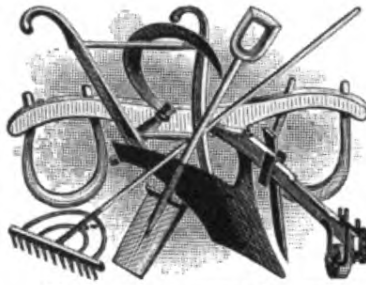

3501. AGRICULTURAL IMPLTS.



3502. APOTHECARY.



3503. ARTIFICIAL FLOWERS.



3504. AUCTIONEER.



3505. BAKER.

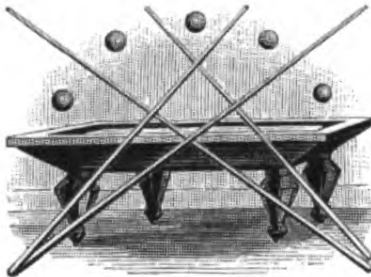

3506. BILLIARDS.

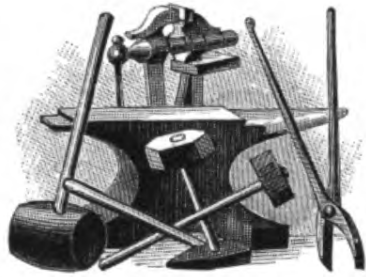

3507. BLACKSMITH.



3508. BLINDS AND SHADES.

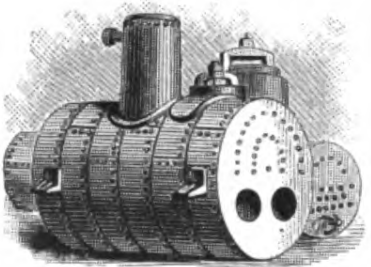

3509. BOILER-MAKER.



3510. BOOKBINDER.



3511. BOOKSTORE.



3512. SHOEMAKER (GENTS').

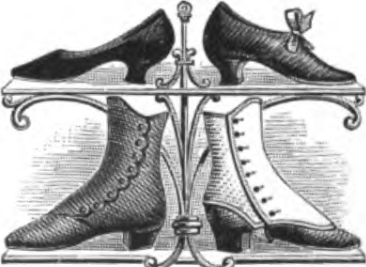

3513. SHOEMAKER (LADIES').



3514. BRASS FOUNDER.

V. B. MUNSON, SUCCESSOR TO
GEO. BRUCE'S SON & CO., 13 CHAMBERS STREET, NEW YORK.

TRADE CUTS

PRICE—FIFTY CENTS EACH

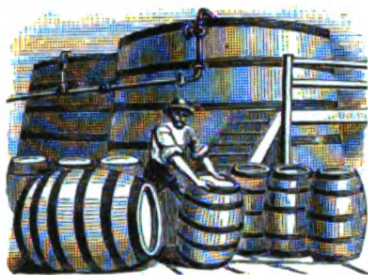

3515. BREWER.



3516. BRIC-A-BRAC.



3517. BRUSH DEALER.

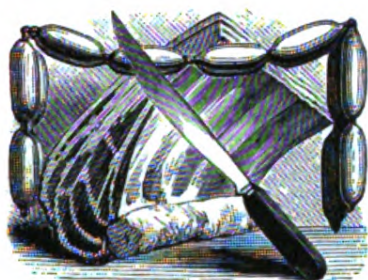

3518. BUTCHER.

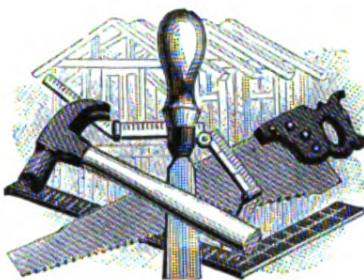

3519. CARPENTER.



3520. CARPETS.



3521. CARRIAGES AND WAGONS.



3522. CATTLE DEALER.



3523. CHAIR MAKER.

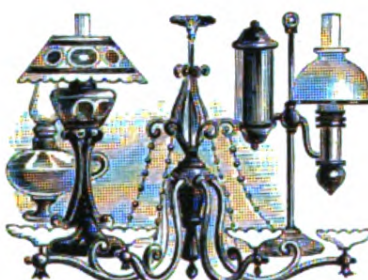

3524. CHANDELIERS AND LAMPS.



3525. CHINA AND GLASSWARE.

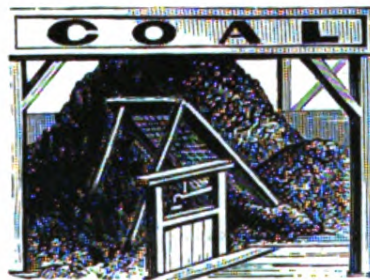

3526. COAL DEALER.

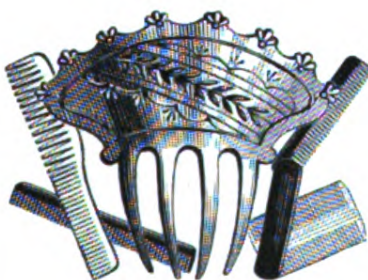

3527. COMB DEALER.



3528. CONFECTIONER.

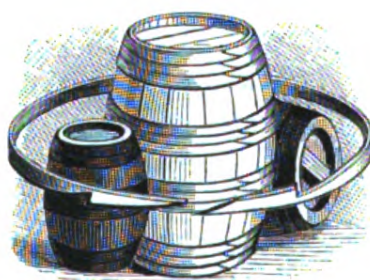

3529. COOPER.

V. B. MUNSON, SUCCESSOR TO
GEO. BRUCE'S SON & CO., 13 CHAMBERS STREET, NEW YORK.

TRADE CUTS

PRICE—FIFTY CENTS EACH

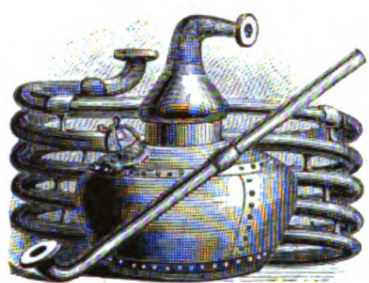

3530. COPPERSMITH.



3531. CUTLER.



3532. DAIRY.

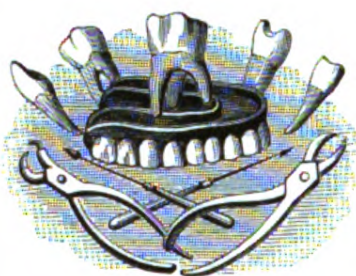

3533. DENTIST.



3534. DOG DEALER.



3535. DRESSMAKER.

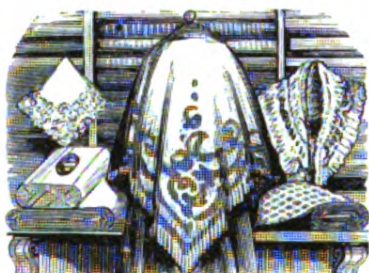

3536. DRY GOODS.



3537. EXPRESS.



3538. FARMER.



3539. FISH DEALER.

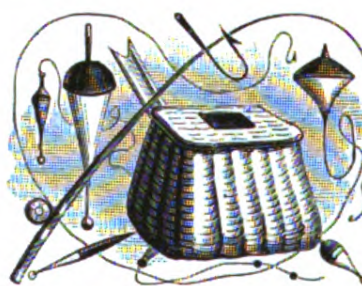

3540. FISHING TACKLE.



3541. FLORIST.



3542. FLOUR AND FEED.



3543. FRUIT.

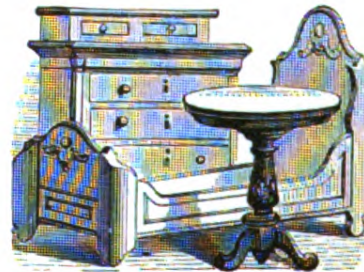

3544. FURNITURE.

V. B. MUNSON, SUCCESSOR TO
GEO. BRUCE'S SON & CO., 13 CHAMBERS STREET, NEW YORK.

TRADE CUTS

PRICE—FIFTY CENTS EACH



3545. FURRIER.

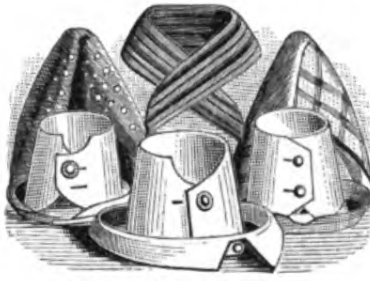

3546. GENTS' FURNISHINGS.



3547. GLOVER.



3548. GROCER.

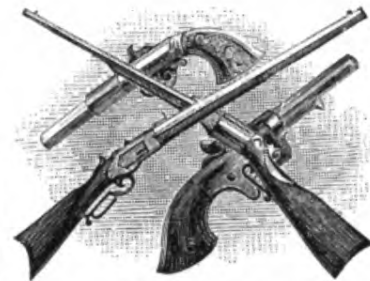

3549. GUNSMITH.



3550. HAIR DRESSER (GENTS').



3551. HAIR DRESSER (LADIES').



3552. HARDWARE.



3553. HARNESS DEALER.

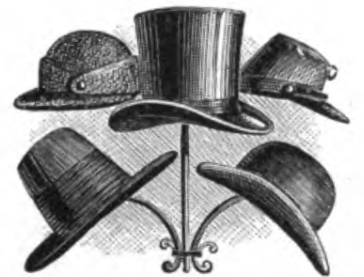

3554. HATTER.



3555. HORSE DEALER.

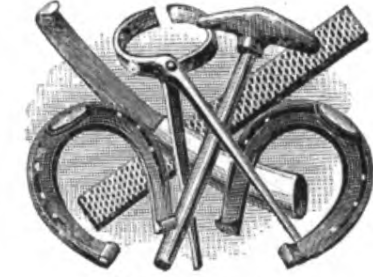

3556. HORSESHOER.



3557. HOSIERY.



3558. ICE.



3559. JEWELER.

V. B. MUNSON, SUCCESSOR TO
GEO. BRUCE'S SON & CO., 13 CHAMBERS STREET, NEW YORK.

TRADE CUTS

PRICE—FIFTY CENTS EACH



3560. KITCHEN FURNISHING.



3561. LAGER BEER.



3562. LAMPS AND OILS.

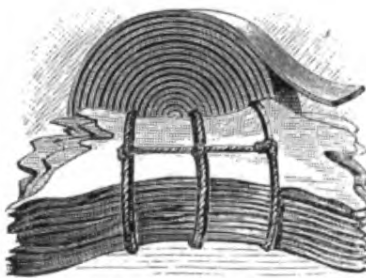

3563. LEATHER DEALER.



3564. LIQUOR DEALER.



3565. LIVERY STABLE.

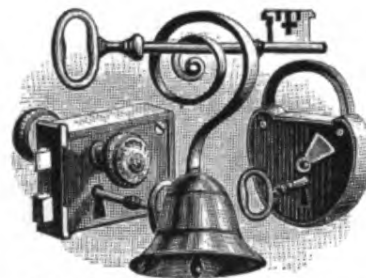

3566. LOCKSMITH AND BELL-HANGER.



3567. LOCOMOTIVE.



3568. LUMBER DEALER.

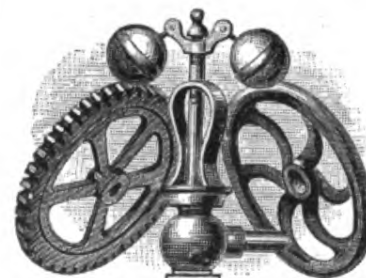

3569. MACHINIST.



3570. MARBLE CUTTER.

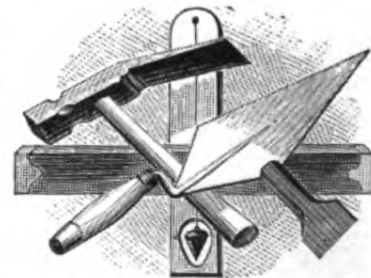

3571. MASON.



3572. MASONIC.



3573. MILLINERY.



3574. MILITARY GOODS.

V. B. MUNSON, SUCCESSOR TO
GEO. BRUCE'S SON & CO., 13 CHAMBERS STREET, NEW YORK.

TRADE CUTS

PRICE—FIFTY CENTS EACH



3575. MINERAL WATERS.

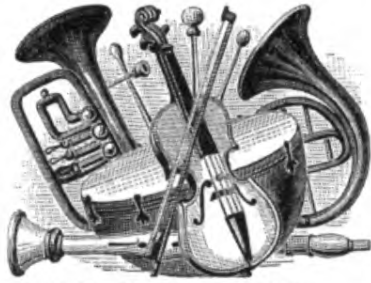

3576. MUSICAL INSTRUMENTS.



3577. MUSIC STORE.

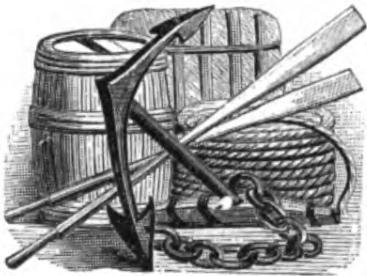

3578. NAVAL.



3579. ODDFELLOWS.



3580. OPTICIAN.



3581. OYSTER HOUSE.



3582. HOUSE PAINTER.



3583. SIGN PAINTER.



3584. PAPER HANGER.



3585. PATRIOTIC.

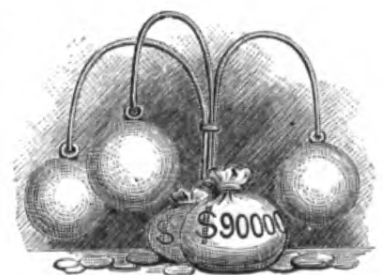

3586. PAWNBROKER.



3587. PERFUMERY.



3588 PHOTOGRAPHER.

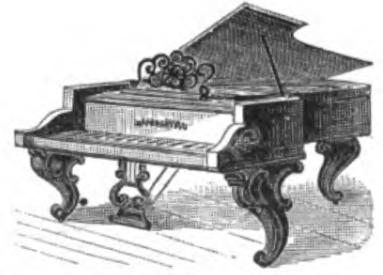

3589. PIANO DEALER.

V. B. MUNSON, SUCCESSOR TO
GEO. BRUCE'S SON & CO., 13 CHAMBERS STREET, NEW YORK.

TRADE CUTS

PRICE—FIFTY CENTS EACH



3590. PICKLES AND PRESERVES.

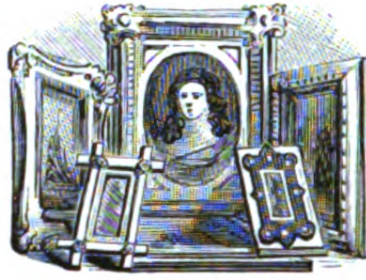

3591. PICTURE FRAMES.

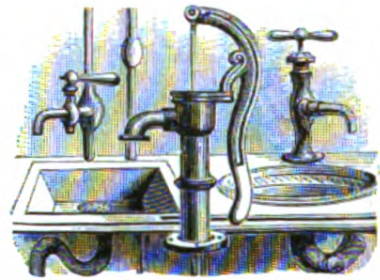

3592. PLUMBER.



3593. PRINTER.

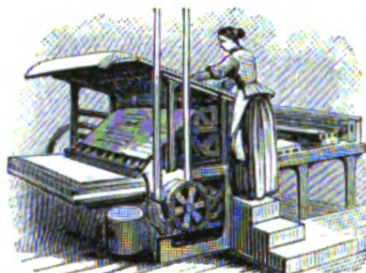

3594. PRINTER.

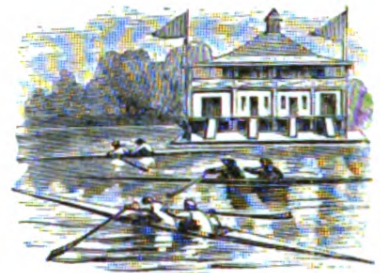

3595. BOAT RACE.

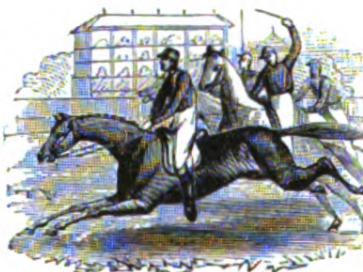

3596. HORSE RACE.



3597. YACHT RACE.



3598. RAILROAD (FREIGHT).



3599. RESTAURANT.

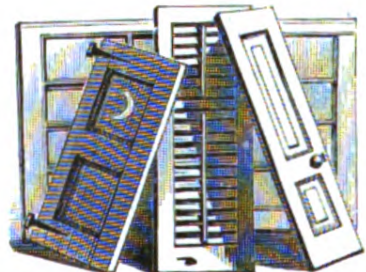

3600. SASHES, BLINDS AND DOORS.

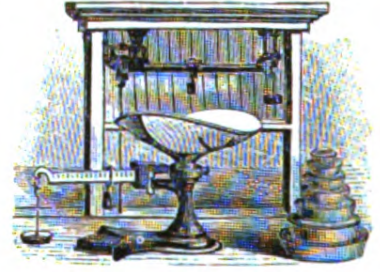

3601. SCALE MAKER.

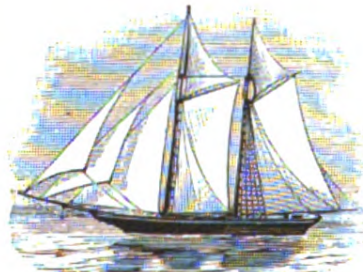

3602. SCHOONER.

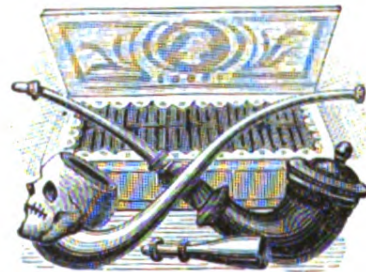

3603. SEGAR DEALER.



3604. SEWING MACHINES.

V. B. MUNSON, SUCCESSOR TO
GEO. BRUCE'S SON & CO., 13 CHAMBERS STREET, NEW YORK.

TRADE CUTS

PRICE—FIFTY CENTS EACH

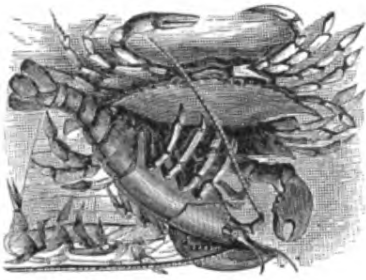

3605. SHELL-FISH DEALER.

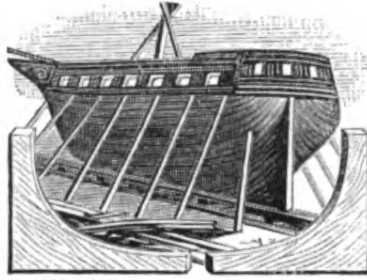

3606. SHIP BUILDER.



3607. SHIP CHANDLER.

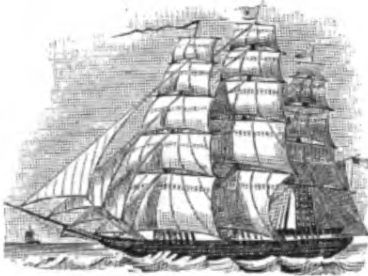

3608. SHIP (CLIPPER).



3609. SHIPPING (FREIGHT).

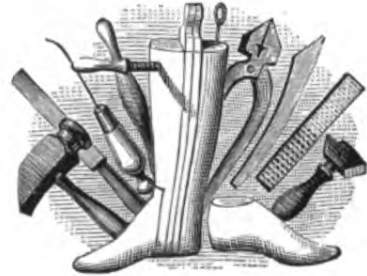

3610. SHOEMAKERS' FINDINGS.



3611. SILVERWARE.

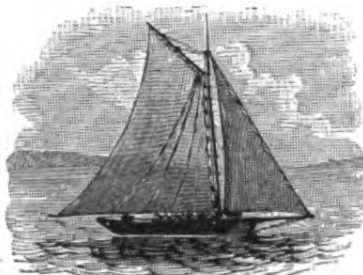

3612. SLOOP.

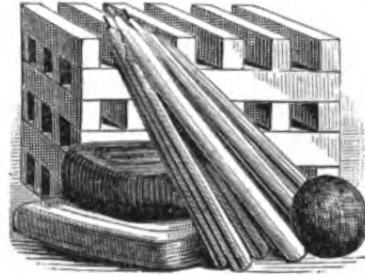

3613. SOAP AND CANDLES.

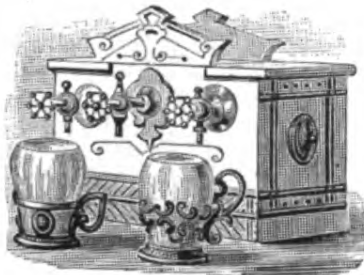

3614. SODA WATER.



3615. STATIONER.

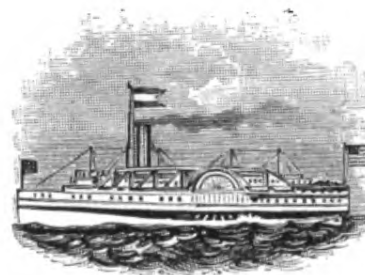

3616. STEAMBOAT.

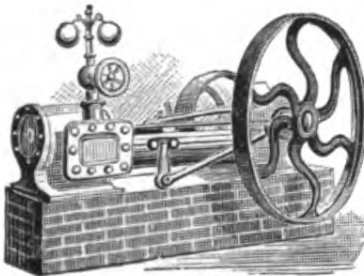

3617. STEAM ENGINE.

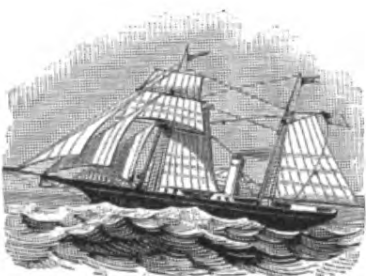

3618. STEAMSHIP.

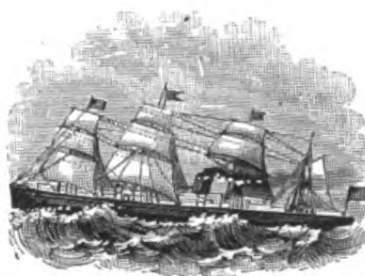

3619. STEAMSHIP.

V. B. MUNSON, SUCCESSOR TO
GEO. BRUCE'S SON & CO., 13 CHAMBERS STREET, NEW YORK.

TRADE CUTS

PRICE—FIFTY CENTS EACH

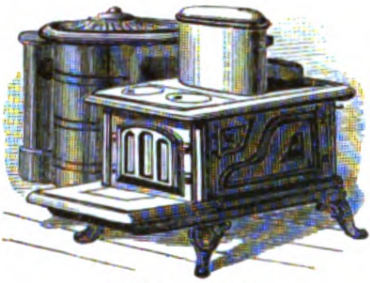

3620. STOVES.

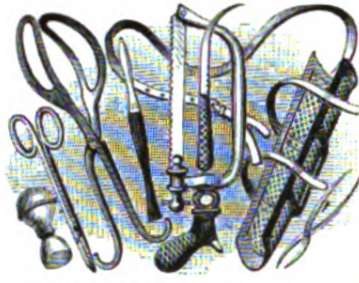

3621. SURGICAL INSTRUMENTS.



3622. TAILOR.



3623. TEA DEALER.



3624. THEATRICAL.



3625. TINWARE.



3626. TOBACCONIST.



3627. TOY DEALER.

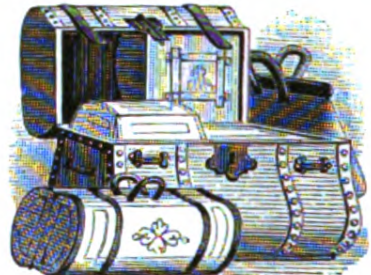

3628. TRUNKS.

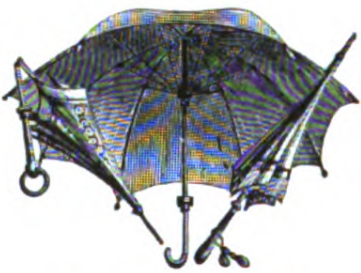

3629. UMBRELLA MAKER.

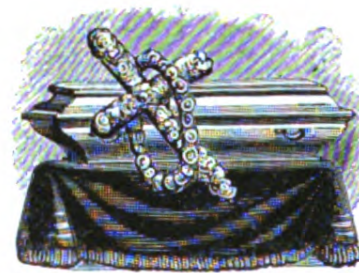

3630. UNDERTAKER.

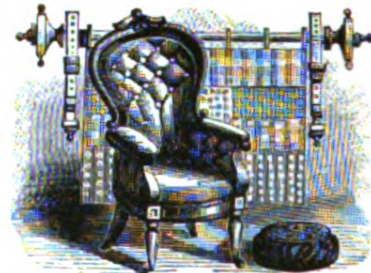

3631. UPHOLSTERER.



3632. WATCHES AND CLOCKS.

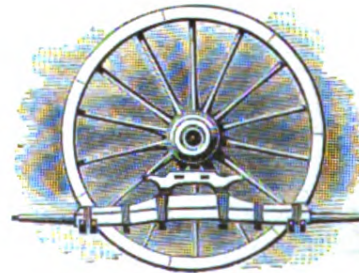

3633. WHEELWRIGHT.



3634. WINE AND BEER GARDEN.

V. B. MUNSON, SUCCESSOR TO
GEO. BRUCE'S SON & CO., 13 CHAMBERS STREET, NEW YORK.

TRADE CUTS

PRICE—ONE DOLLAR EACH



2700. AGRICULTURE.

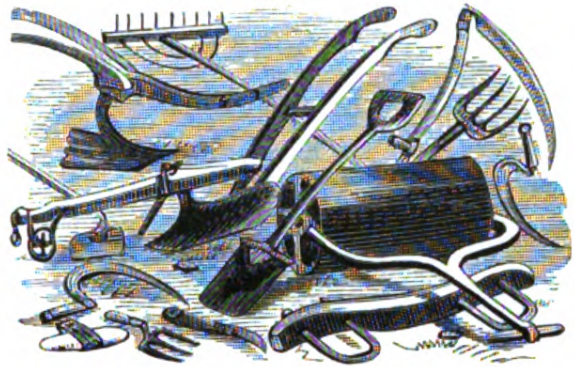

2701. AGRICULTURAL IMPLEMENTS.

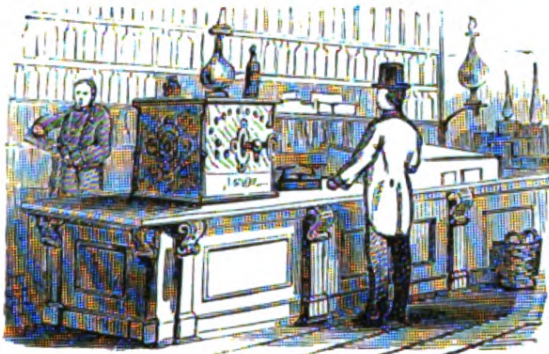

2702. APOTHECARY.

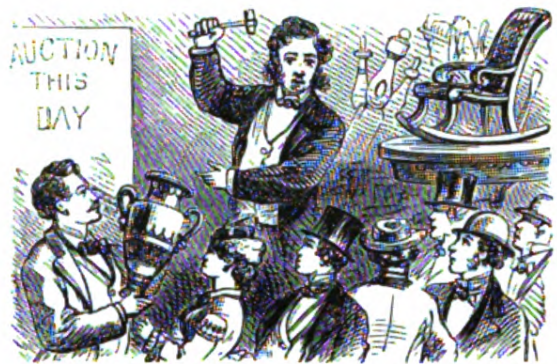

2703. AUCTIONEER.

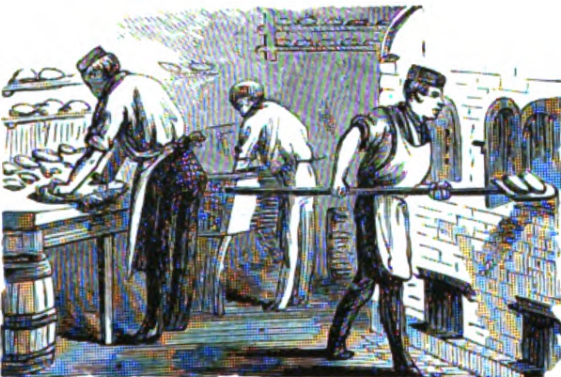

2704. BAKER.

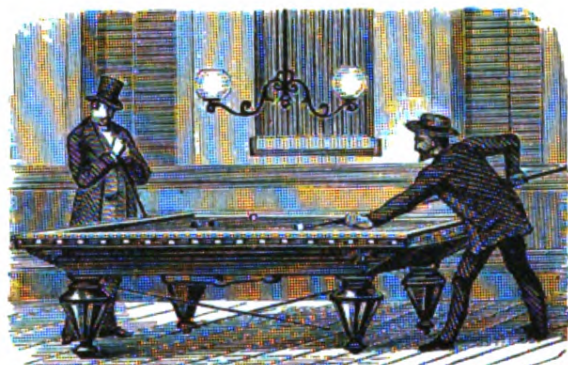

2705. BILLIARDS.

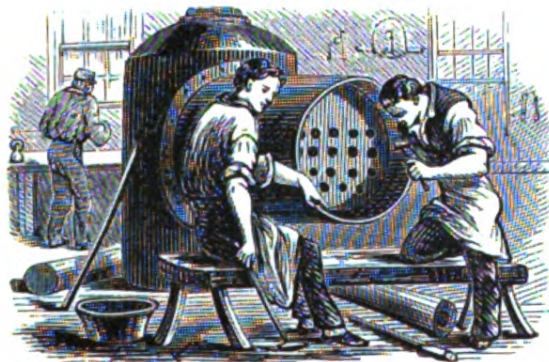

2706. BOILER MAKER.

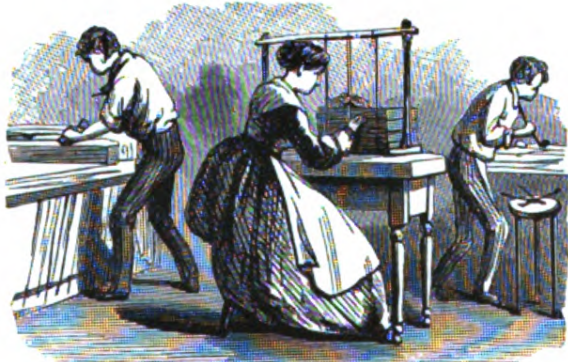

2707. BOOKBINDER.

V. B. MUNSON, SUCCESSOR TO
GEO. BRUCE'S SON & CO., 13 CHAMBERS STREET, NEW YORK.

TRADE CUTS

PRICE—ONE DOLLAR EACH



2708. BOOKSTORE.



2709. BOOTS AND SHOES (GENTS').



2710. BOOTS AND SHOES (LADIES').

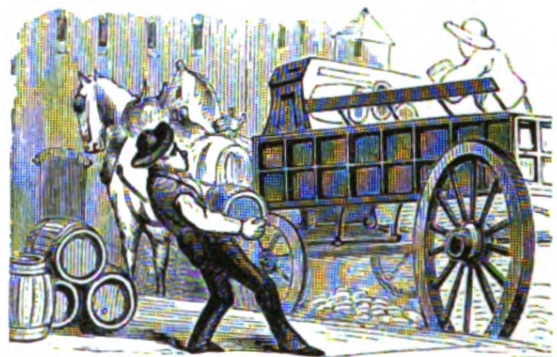

2711. BREWER.

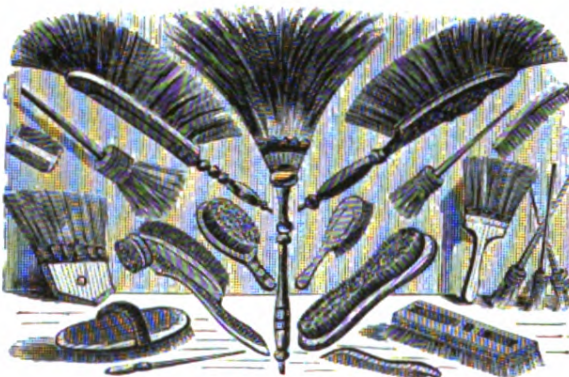

2712. BRUSH DEALER.

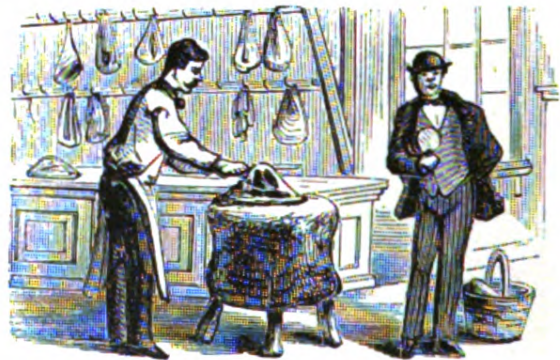

2713. BUTCHER.

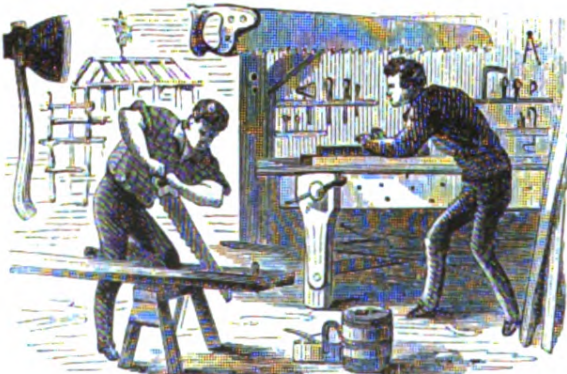

2714. CARPENTER.

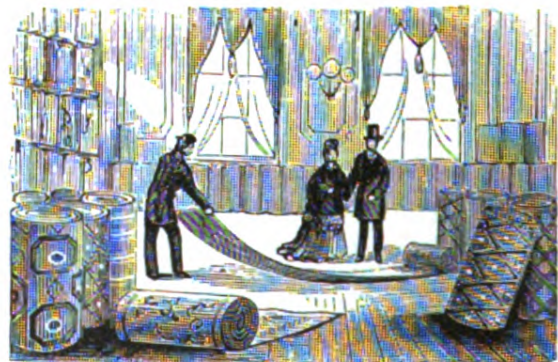

2715. CARPETS.

V. B. MUNSON, SUCCESSOR TO
GEO. BRUCE'S SON & CO., 13 CHAMBERS STREET, NEW YORK.

TRADE CUTS

PRICE—ONE DOLLAR EACH

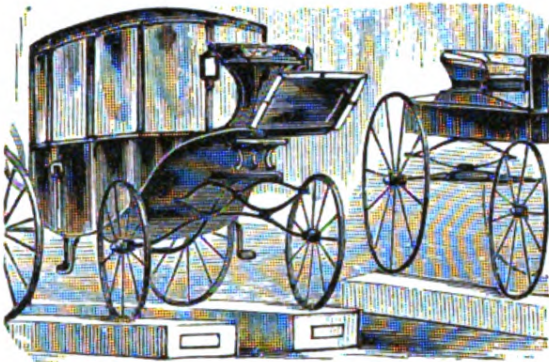

2716. CARRIAGES AND WAGONS.

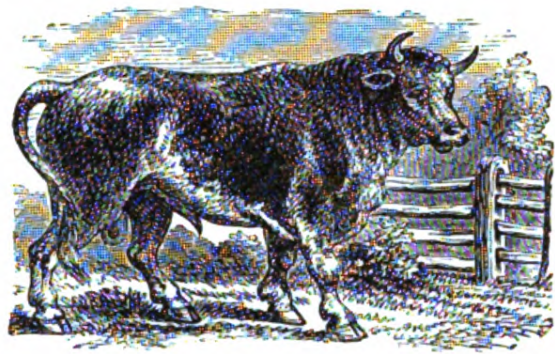

2717. CATTLE DEALER.

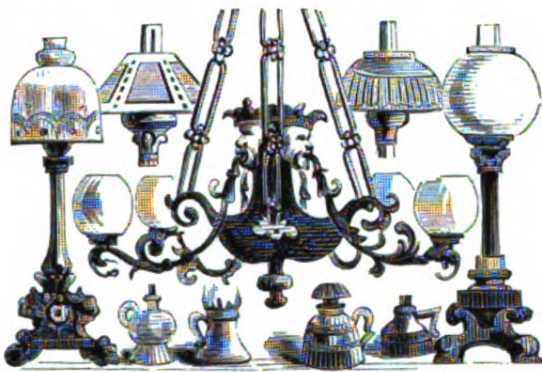

2718. CHANDELIERS.



2719. CHINA AND GLASSWARE.



2720. COAL DEALER.



2721. COAL MINER.



2722. CONFECTIONERY.



2723. COOPER.

V. B. MUNSON, SUCCESSOR TO
GEO. BRUCE'S SON & CO., 13 CHAMBERS STREET, NEW YORK.

TRADE CUTS

PRICE—ONE DOLLAR EACH



2724. CUTLER.



2725. DENTIST.



2726. DRESSMAKER.



2727. DRIVING.



2728. DRY GOODS.



2729. EXPRESS.



2730. FARMER.

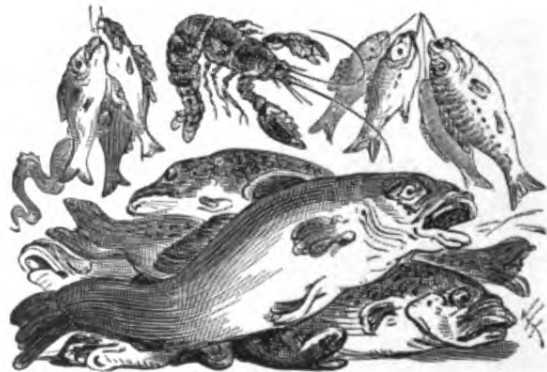

2731. FISH DEALER.

V. B. MUNSON, SUCCESSOR TO
GEO. BRUCE'S SON & CO., 13 CHAMBERS STREET, NEW YORK.

TRADE CUTS

PRICE—ONE DOLLAR EACH

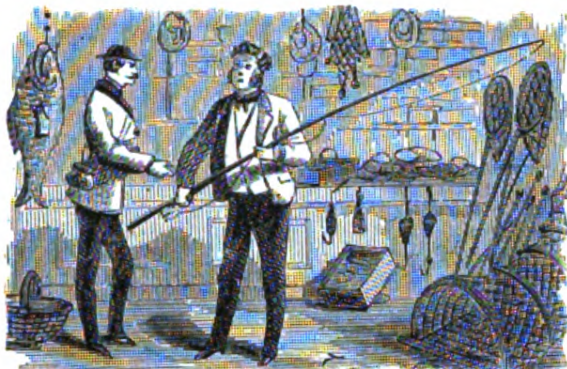

2732. FISHING TACKLE.



2733. FLORIST.



2734. FLOUR AND FEED.

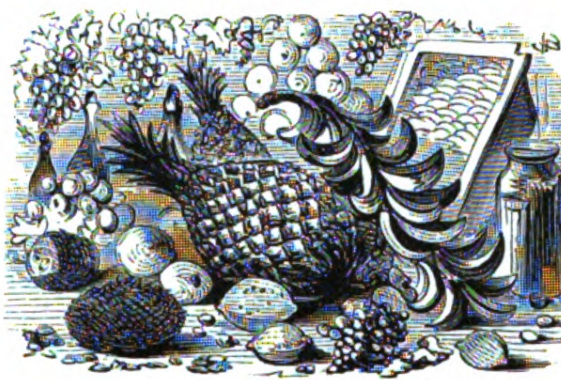

2735. FRUIT.

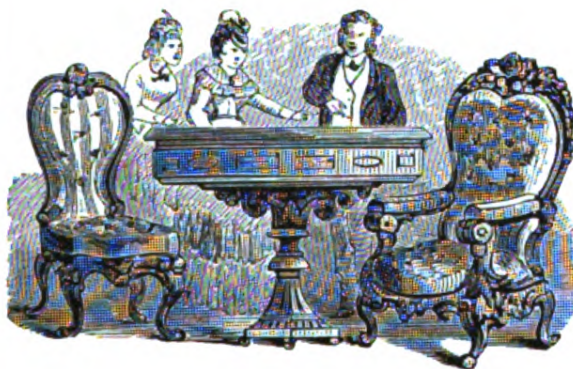

2736. FURNITURE.



2737. FURRER.

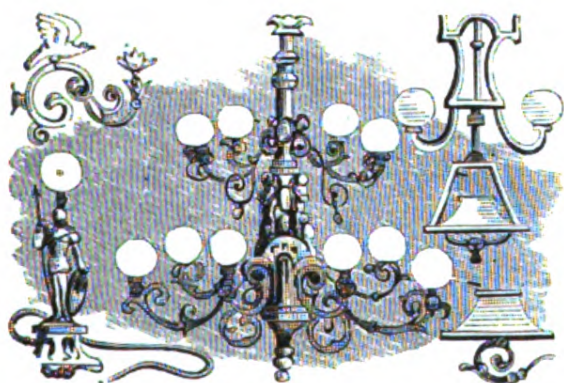

2738. GAS FIXTURES.

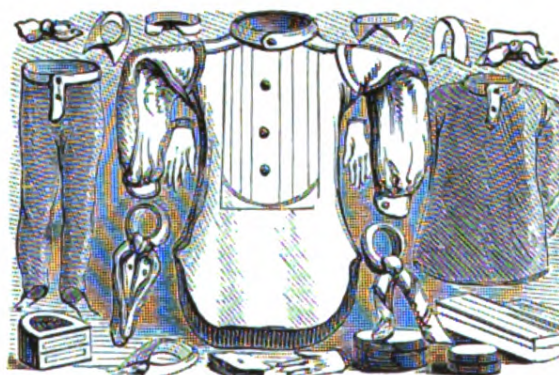

2739. GENTS' FURNISHINGS.

V. B. MUNSON, SUCCESSOR TO
GEO. BRUCE'S SON & CO., 13 CHAMBERS STREET, NEW YORK.

TRADE CUTS

PRICE—ONE DOLLAR EACH

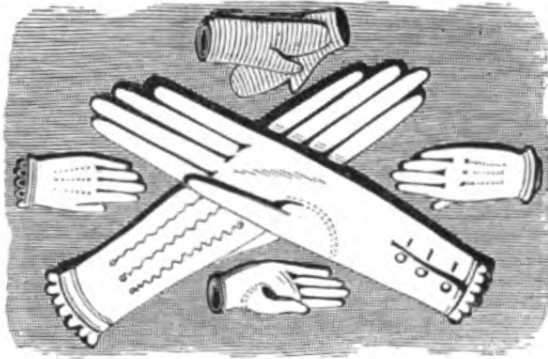

2740. GLOVER.



2741. GROCER.

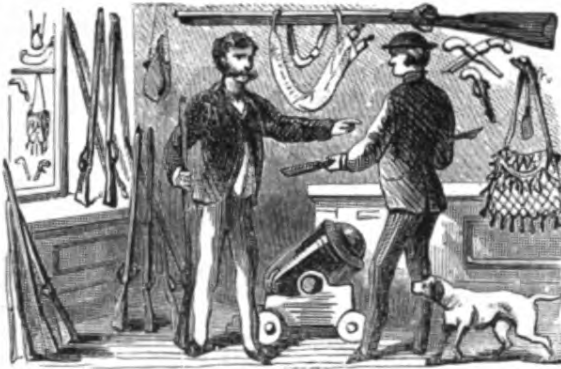

2742. GUNSMITH.



2743. HAIR DRESSER (GENTS').



2744. HAIR DRESSER (LADIES').

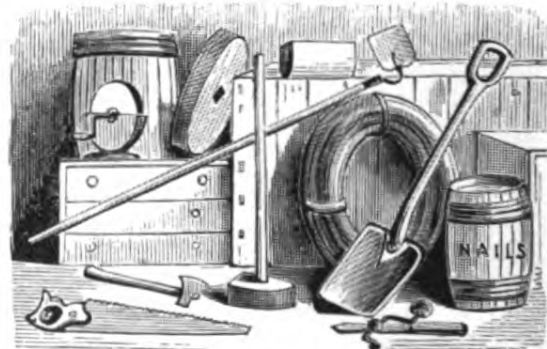

2745. HARDWARE.

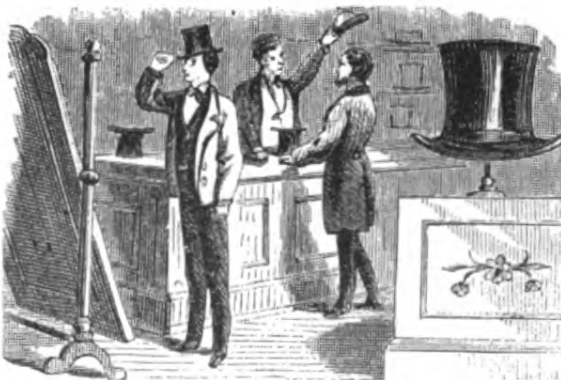

2746. HATTER.

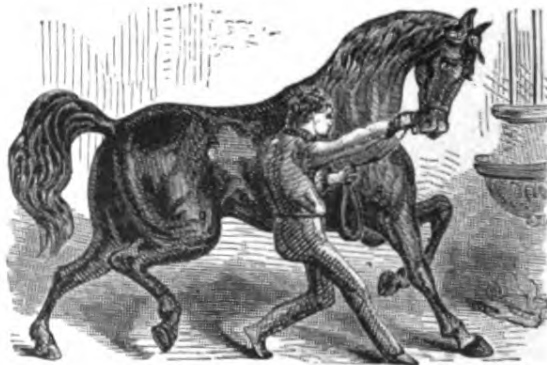

2747. HORSE DEALER.

V. B. MUNSON, SUCCESSOR TO
GEO. BRUCE'S SON & CO., 13 CHAMBERS STREET, NEW YORK.

TRADE CUTS

PRICE—ONE DOLLAR EACH

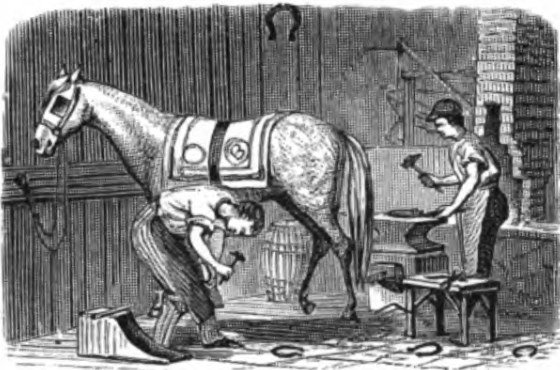

2748. HORSESHOER.



2749. HOSIERY



2750. ICE.

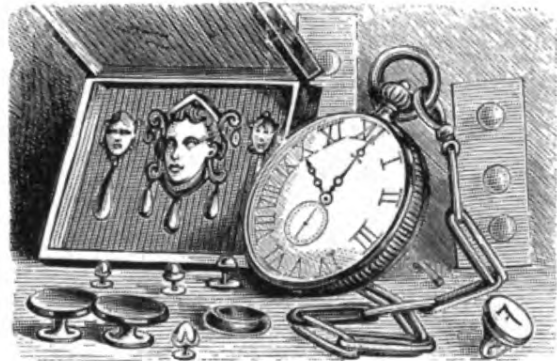

2751. JEWELER.



2752. KITCHEN FURNISHINGS.



2753. LAGER BEER.



2754. LAMP DEALER.



2755. LIVERY STABLE.

V. B. MUNSON, SUCCESSOR TO
GEO. BRUCE'S SON & CO., 13 CHAMBERS STREET, NEW YORK.

TRADE CUTS

PRICE—ONE DOLLAR EACH

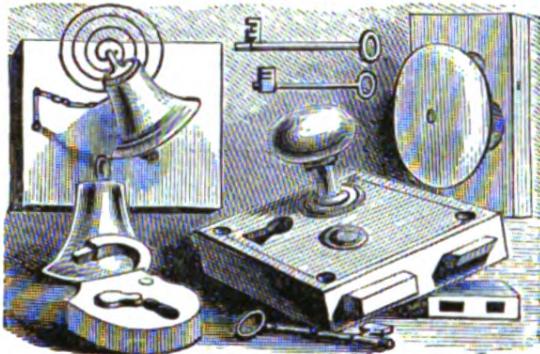

2756. LOCKSMITH AND BELL-HANGER.

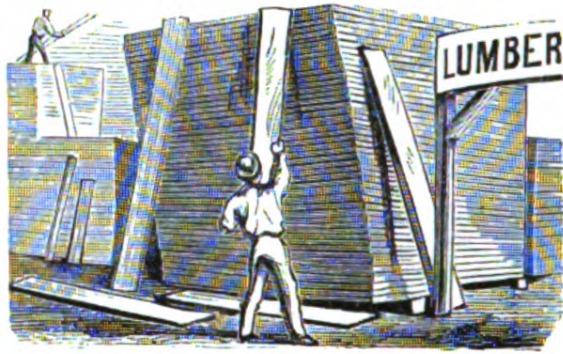

2757. LUMBER DEALER.

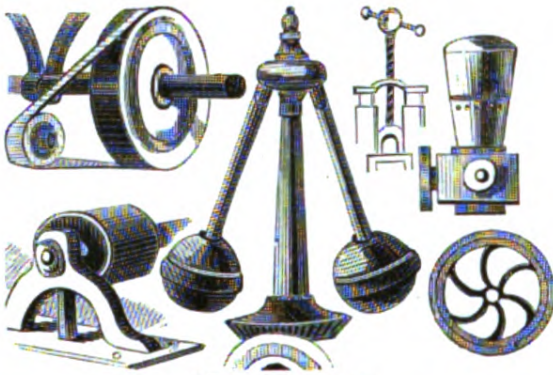

2758. MACHINIST.



2759. MARBLE WORKS.

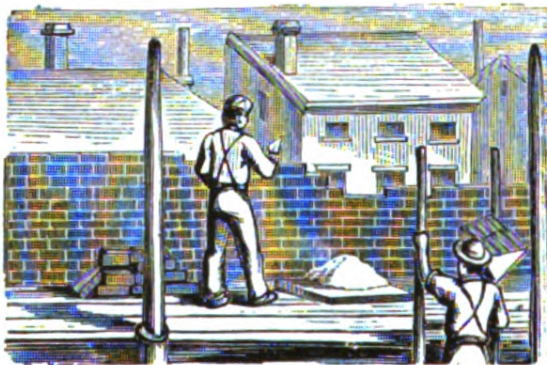

2760. MASON

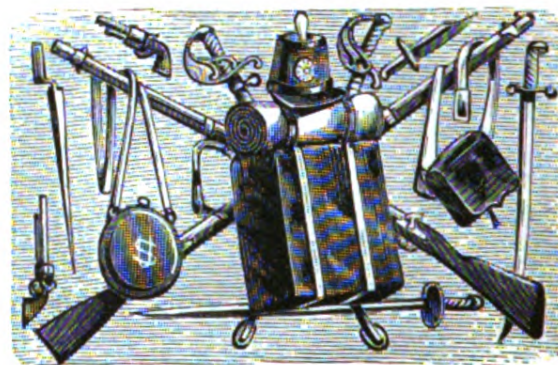

2761. MILITARY GOODS.

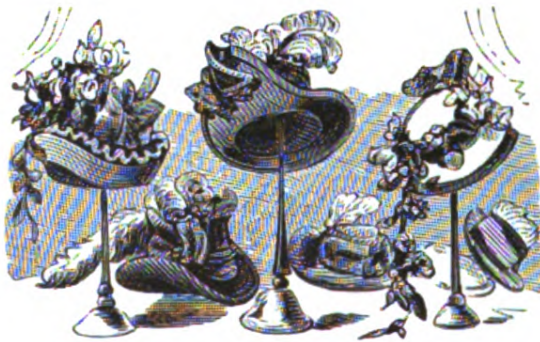

2762. MILLINERY.

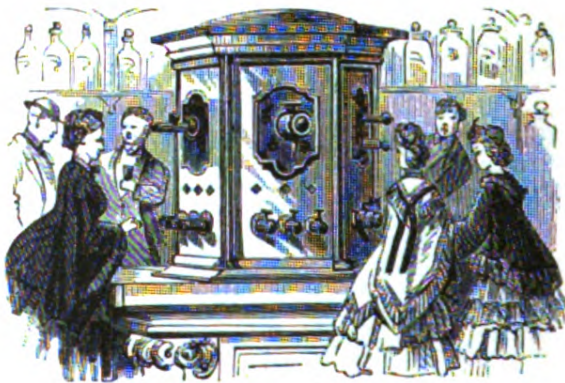

2763. MINERAL WATER.

V. B. MUNSON, SUCCESSOR TO
GEO. BRUCE'S SON & CO., 13 CHAMBERS STREET, NEW YORK.

TRADE CUTS

PRICE—ONE DOLLAR EACH

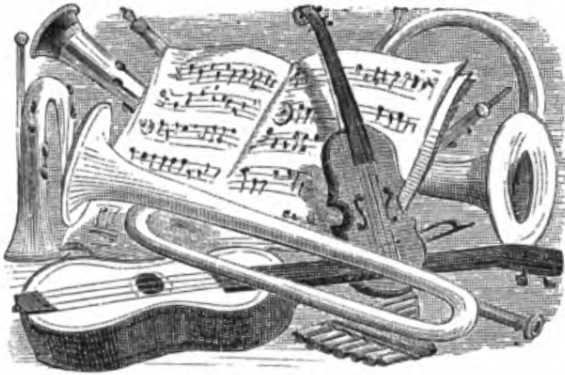

2764. MUSICAL INSTRUMENTS.



2765. MUSIC (INSTRUMENTAL).



2766. MUSIC (MILITARY).



2767. MUSIC (PIANO).



2768. MUSIC (SACRED).



2769. MUSIC (VOCAL).



2770. NAVAL.

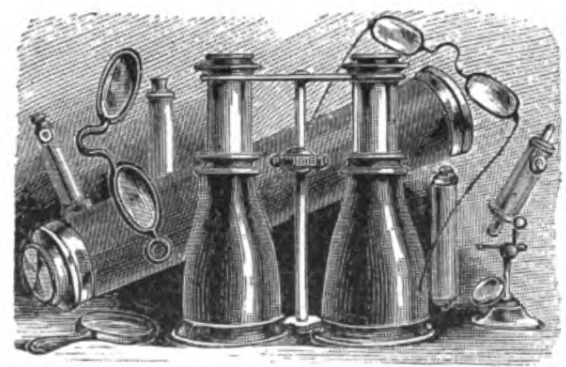

2771. OPTICAL.

V. B. MUNSON, SUCCESSOR TO
GEO. BRUCE'S SON & CO., 13 CHAMBERS STREET, NEW YORK.

TRADE CUTS

PRICE—ONE DOLLAR EACH

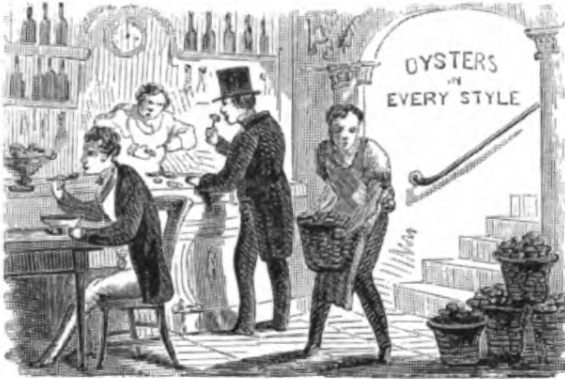

2772. OYSTER HOUSE.

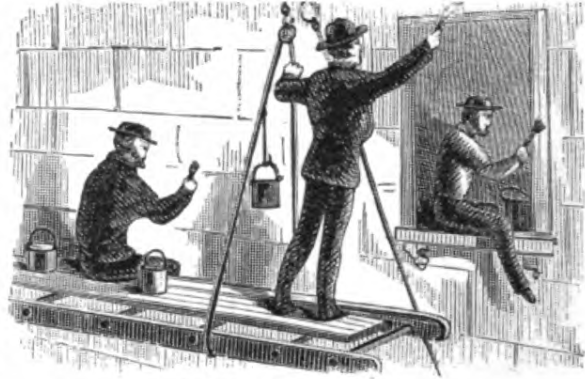

2773. HOUSE PAINTER.



2774. SIGN PAINTER.



2775. PAPER HANGER.



2776. PIANO DEALER.



2777. PICKLES.

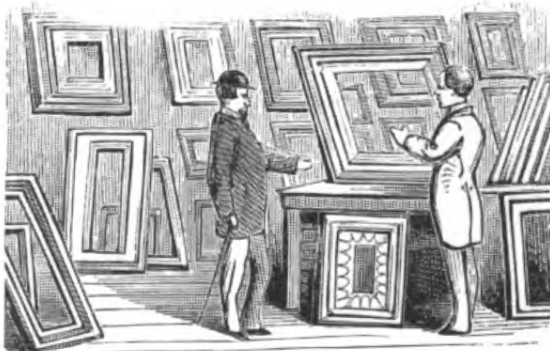

2778. PICTURE FRAMES.

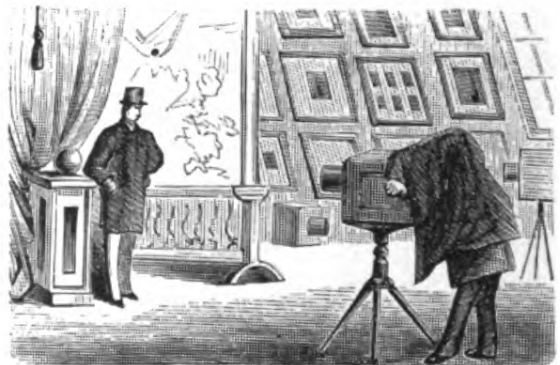

2779. PHOTOGRAPHER.

V. B. MUNSON, SUCCESSOR TO
GEO. BRUCE'S SON & CO., 13 CHAMBERS STREET, NEW YORK.

TRADE CUTS

PRICE—ONE DOLLAR EACH



2780. COTTON PLANTER.



2781. SUGAR PLANTER.



2782. TOBACCO PLANTER.

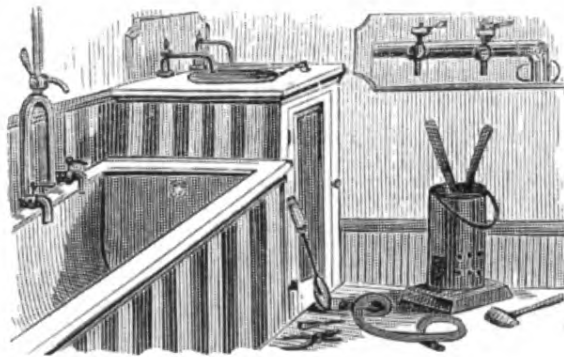

2783. PLUMBER.

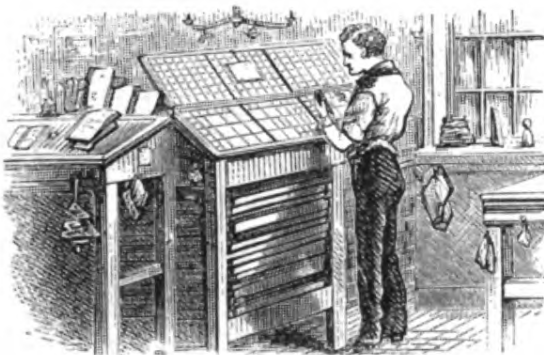

2784. PRINTER.

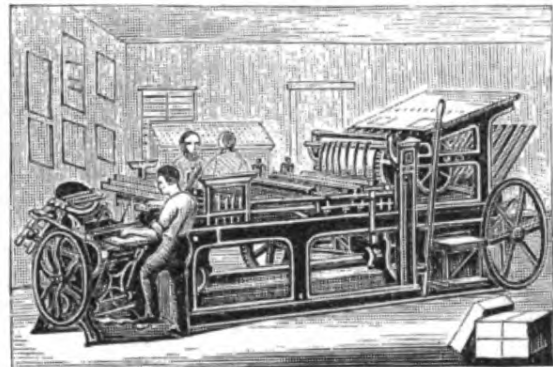

2785. PRINTER.

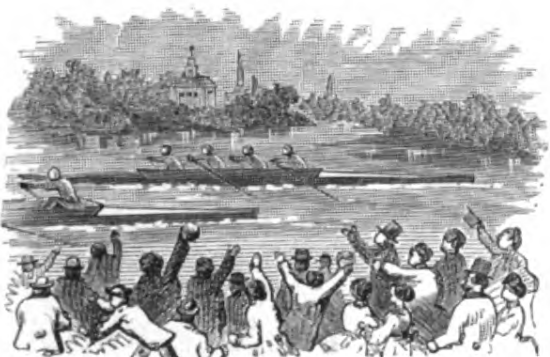

2786. BOAT RACE.

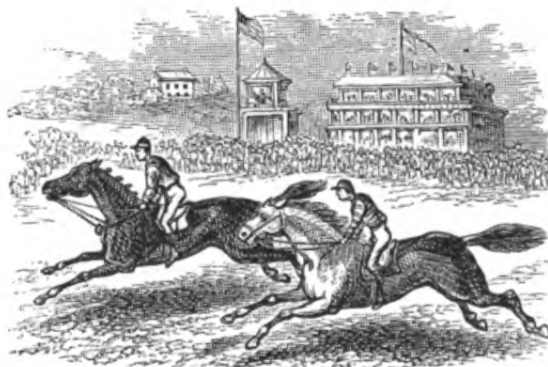

2787. HORSE RACE.

V. B. MUNSON, SUCCESSOR TO
GEO. BRUCE'S SON & CO., 13 CHAMBERS STREET, NEW YORK.

TRADE CUTS

PRICE—ONE DOLLAR EACH

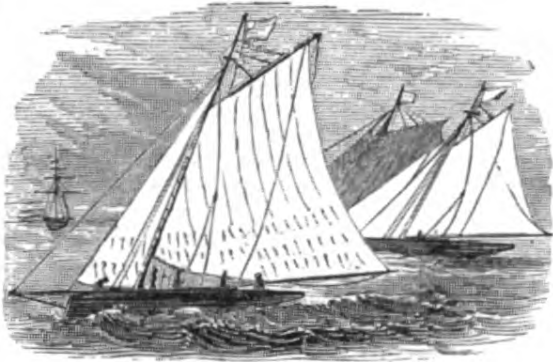

2788. YACHT RACE.



2789. RAILROAD (FREIGHT).



2790. RESTAURANT.



2791. SADDLERY.



2792. SASH, BLINDS AND DOORS.

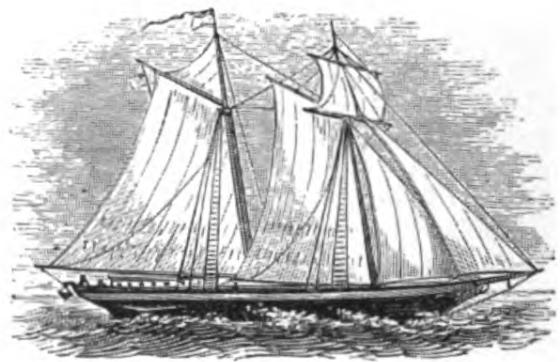

2793. SCHOONER.



2794. SEGAR DEALER.



2795. SEWING MACHINES.

V. B. MUNSON, SUCCESSOR TO
GEO. BRUCE'S SON & CO., 13 CHAMBERS STREET, NEW YORK.

TRADE CUTS

PRICE—ONE DOLLAR EACH



2796. SHIP-BUILDER.

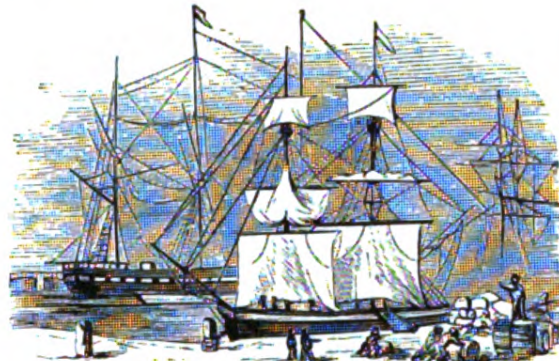

2797. SHIPPING.



2798. SHIPPING.

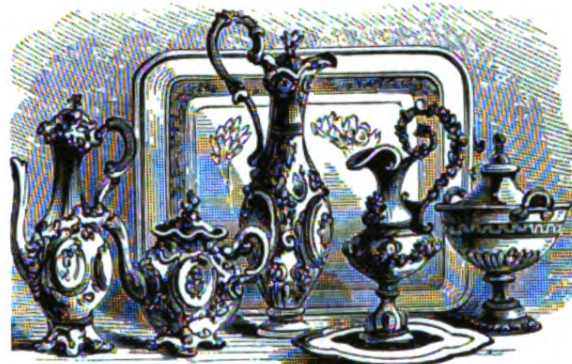

2799. SILVERWARE.

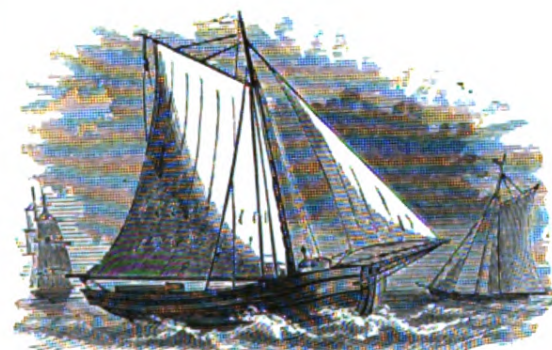

2800. SLOOP.



2801. STATIONER.

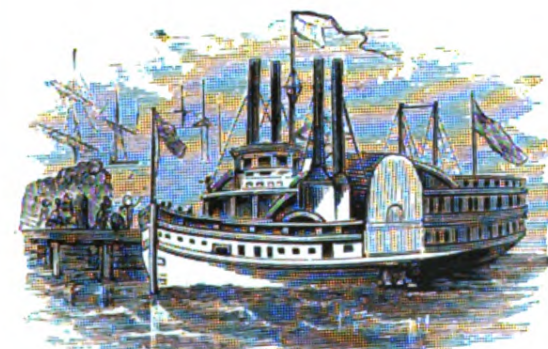

2802. STEAMBOAT.

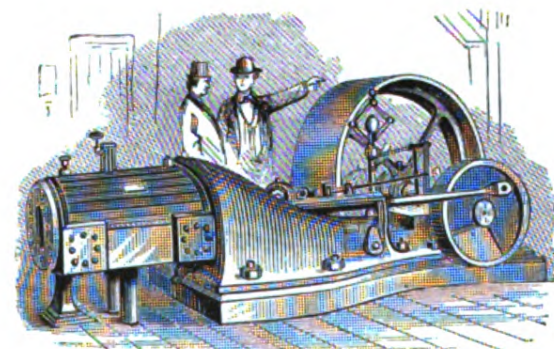

2803. STEAM ENGINE.

V. B. MUNSON, SUCCESSOR TO
GEO. BRUCE'S SON & CO., 13 CHAMBERS STREET, NEW YORK.

TRADE CUTS

PRICE—ONE DOLLAR EACH

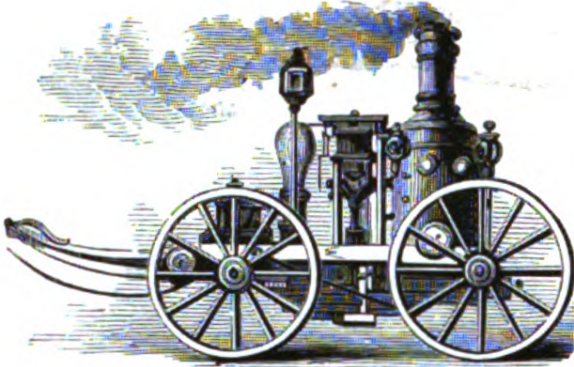

2804. STEAM FIRE ENGINE.

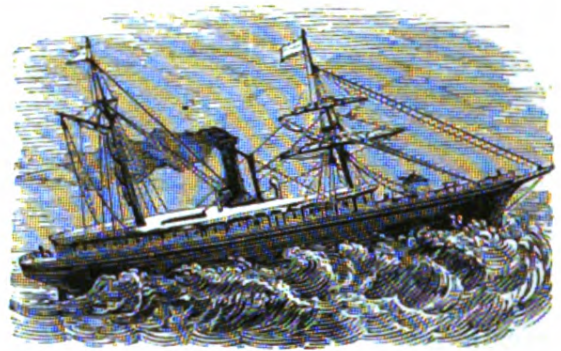

2805. STEAMSHIP

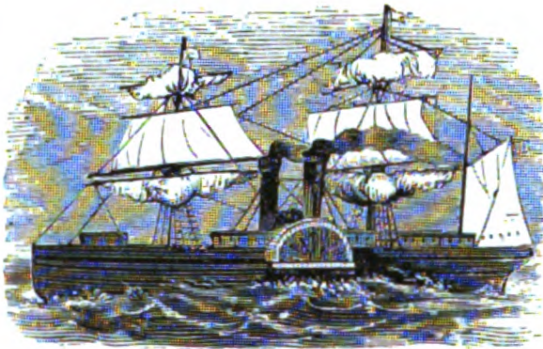

2806. STEAMSHIP.

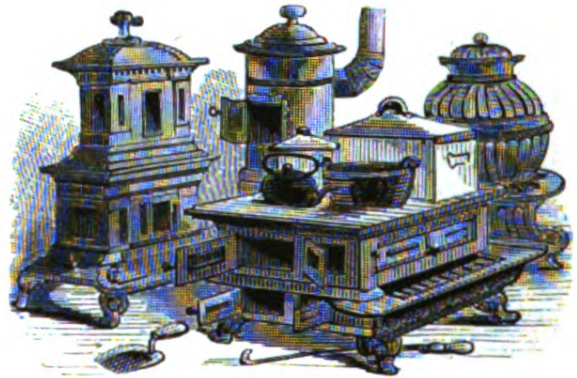

2807. STOVES.

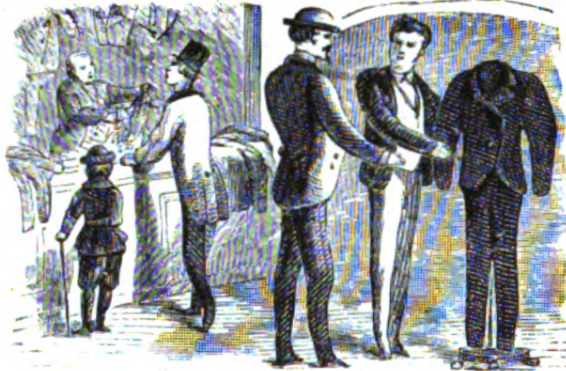

2808. TAILOR.

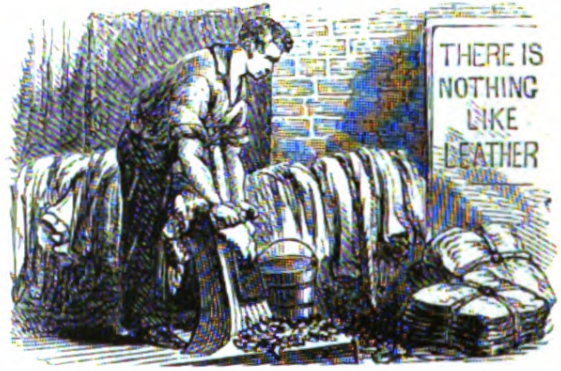

2809. TANNER.

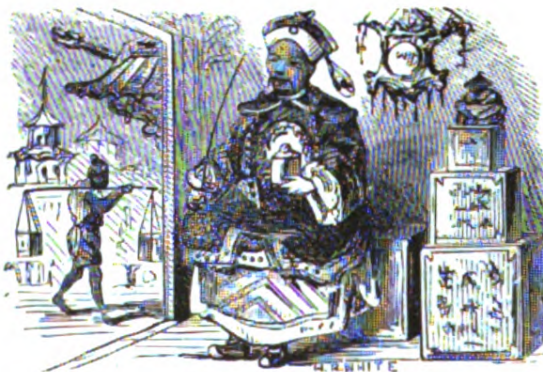

2810. TEA DEALER.



2811. THEATRICAL.

V. B. MUNSON, SUCCESSOR TO
GEO. BRUCE'S SON & CO., 13 CHAMBERS STREET, NEW YORK.

TRADE CUTS

PRICE—ONE DOLLAR EACH



2812. TINWARE.

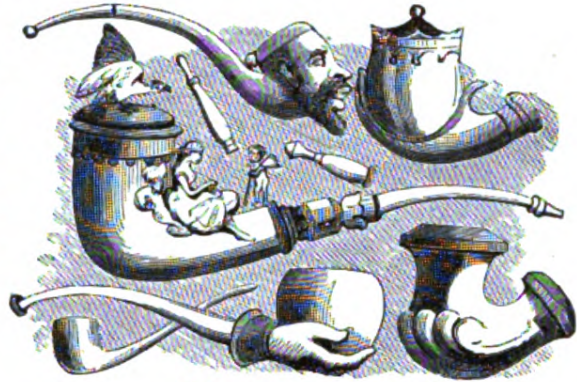

2813. PIPE DEALER.

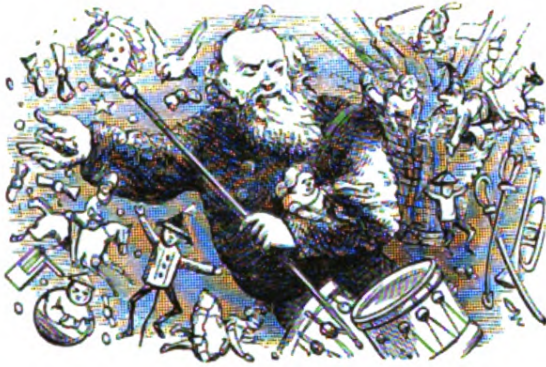

2814. TOY DEALER.

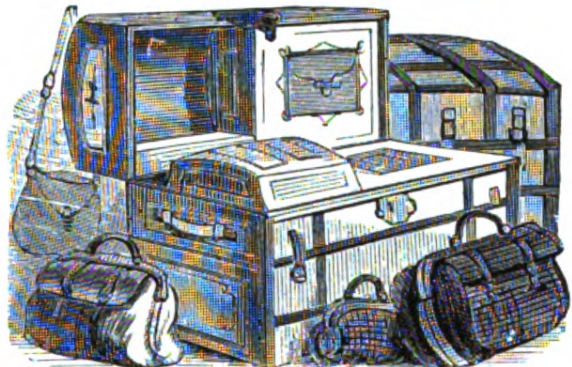

2815. TRUNKS.

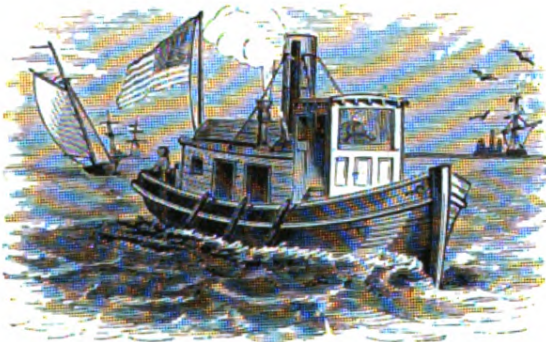

2816. TUG-BOAT.



2817. UMBRELLA DEALER.



2818. UNDERTAKER.



2819. UPHOLSTERER.

V. B. MUNSON, SUCCESSOR TO
GEO. BRUCE'S SON & CO., 13 CHAMBERS STREET, NEW YORK.

TRADE CUTS

PRICE—ONE DOLLAR EACH

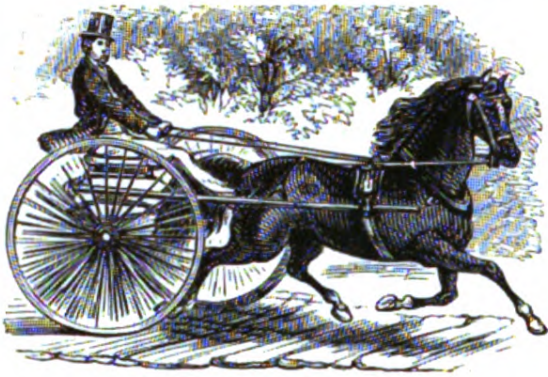

2820. DRIVING.

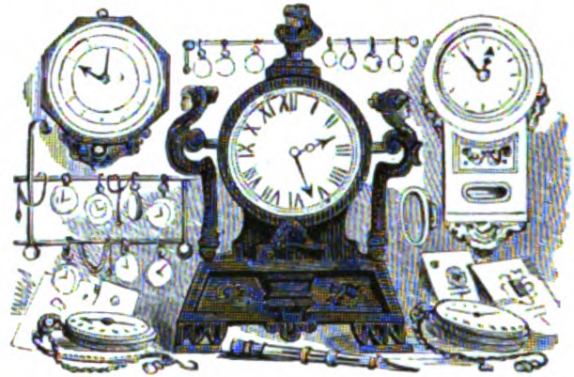

2821. WATCHES AND CLOCKS.



2822. WHEELWRIGHT.



2823. WINE AND BEER GARDEN.



2824. WINE DEALER.



2825. WILLOW WARE.

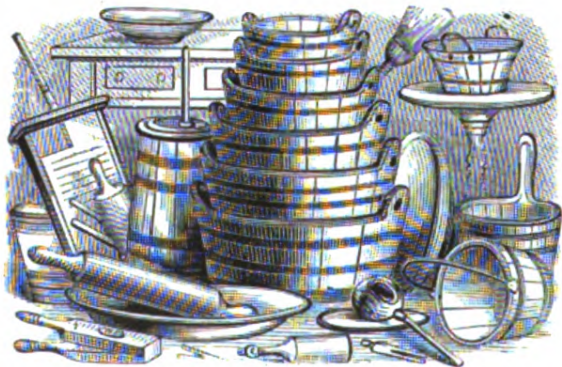

2826. WOODEN WARE.



2827. YANKEE NOTIONS.

V. B. MUNSON, SUCCESSOR TO
GEO. BRUCE'S SON & CO., 13 CHAMBERS STREET, NEW YORK.

ELECTROTYPE ORNAMENTS



3201-40c.



3167-40c.



3165-40c.



3177-40c.



3161-40c.



3190-40c.



3176-40c.



3159-40c.



3158-40c.



3196-40c.



3042-50c.



3160-40c.



3040-60c.



3041-60c.



3150-75c.



3067-50c.



3069-50c.



3063-50c.



3060-50c.



3061-50c.



3053-50c.



3064-50c.

V. B. MUNSON, SUCCESSOR TO
GEO. BRUCE'S SON & CO., 13 CHAMBERS STREET, NEW YORK.

HEAD AND TAIL PIECES



3047—\$1.25.



3205—\$1.25.



3044—50c.



3117—\$1.00.



3155—75c.



3122—75c.



3054—60c.



3046—\$1.00.



3014—75c.



3157—\$1.00.



3015—75c.



3153—\$1.25.



3152—\$1.00.

V. B. MUNSON, SUCCESSOR TO
GEO. BRUCE'S SON & CO., 13 CHAMBERS STREET, NEW YORK.

HEAD AND TAIL PIECES



3002—\$1.25.



3005—\$1.25.



3109—\$1.00.



3020—\$1.25.



3023—\$1.25.



3083—\$1.50.



3084—\$1.50.



3085—\$1.50.



3068—25c.



3070—25c.



3071—25c.



3072—25c.



3073—25c.



3074—25c.



3075—25c.

V. B. MUNSON, SUCCESSOR TO
GEO. BRUCE'S SON & CO., 13 CHAMBERS STREET, NEW YORK.

HEAD AND TAIL PIECES



3086—\$1.50.



3088—\$1.50.



3062—50c.



3204—15c.



3028—\$1.25.



3030—\$1.25.



3032—\$1.25.



3034—\$1.25.

V. B. MUNSON, SUCCESSOR TO
GEO. BRUCE'S SON & CO., 13 CHAMBERS STREET, NEW YORK.

UNITED STATES EMBLEMS



3900—25c.



3901—30c.



3903—50c.



3905—\$1.25.



3907—\$1.25.

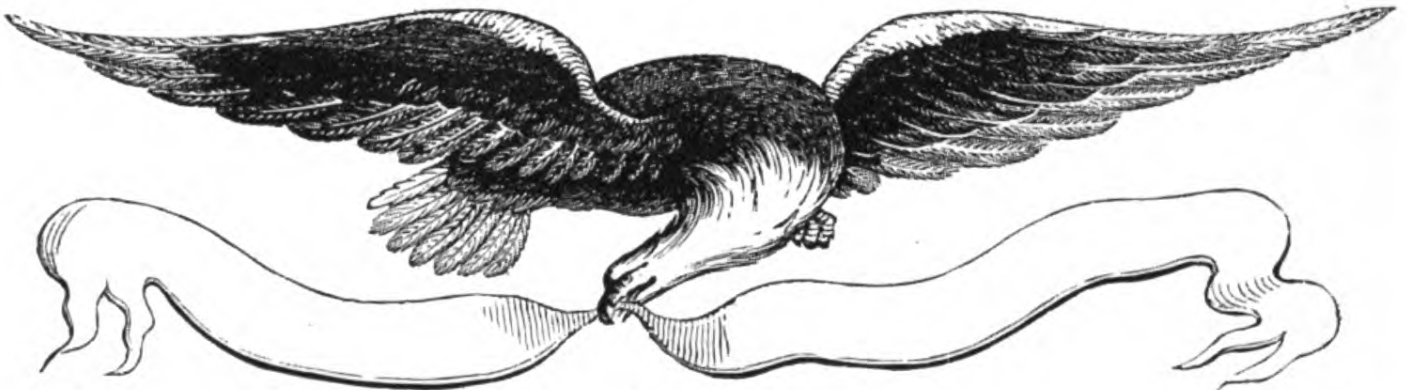

3908—\$2.00.



3906—\$1.00.



3904—50c.



3902—30c.

V. B. MUNSON, SUCCESSOR TO
GEO. BRUCE'S SON & CO., 13 CHAMBERS STREET, NEW YORK.

UNITED STATES FLAGS



1926—75c.; Two colors, \$1.50.



1928—\$1.00; Two colors, \$2.00.



5555—25c.



1933—50c.; Two colors, \$1.00.



1927—62c.; Two colors, \$1.25.



1933B—50c.



1929—75c.; Two colors, \$1.50.



1929B—75c.

V. B. MUNSON, SUCCESSOR TO
GEO. BRUCE'S SON & CO., 13 CHAMBERS STREET, NEW YORK.

G. A. R. AND K. OF P. EMBLEMS



5004—\$1.00.

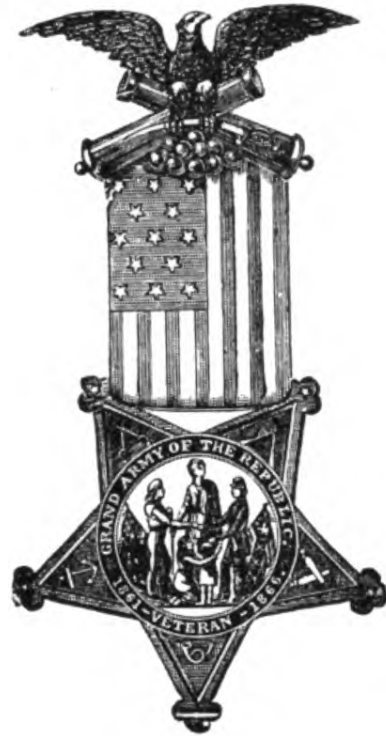

5003—75c.

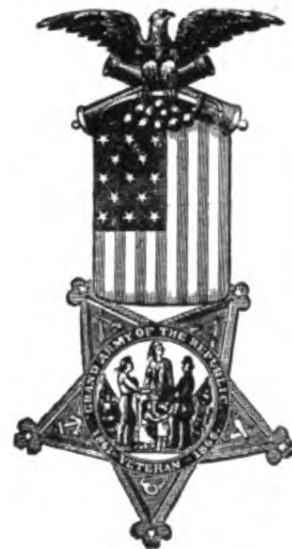

5002—60c.



5000—30c.



5001—30c.



5007—75c.



5006—60c.



5005—50c.

V. B. MUNSON, SUCCESSOR TO
GEO. BRUCE'S SON & CO., 13 CHAMBERS STREET, NEW YORK.

RELIGIOUS CUTS

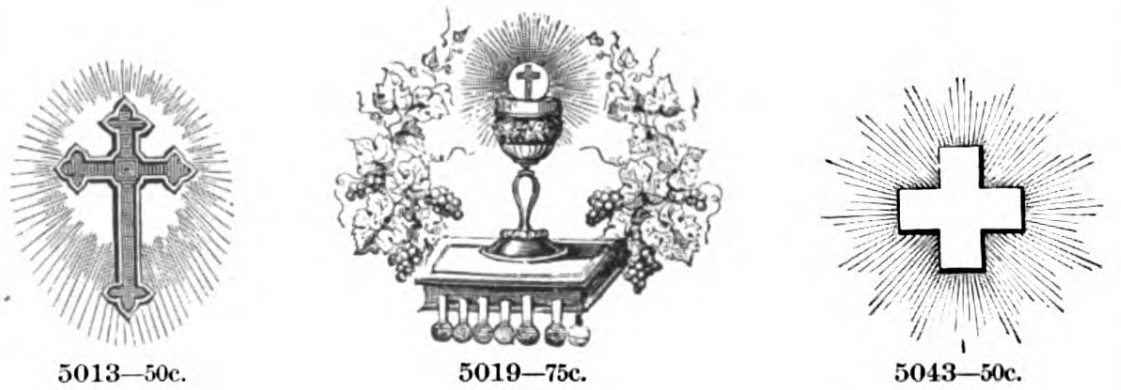
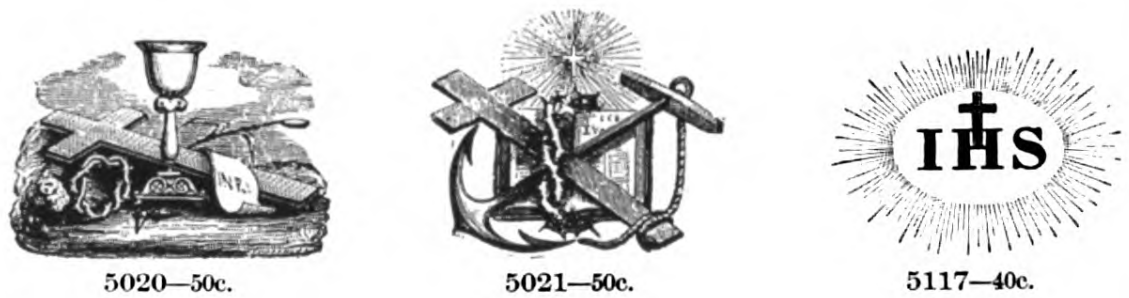
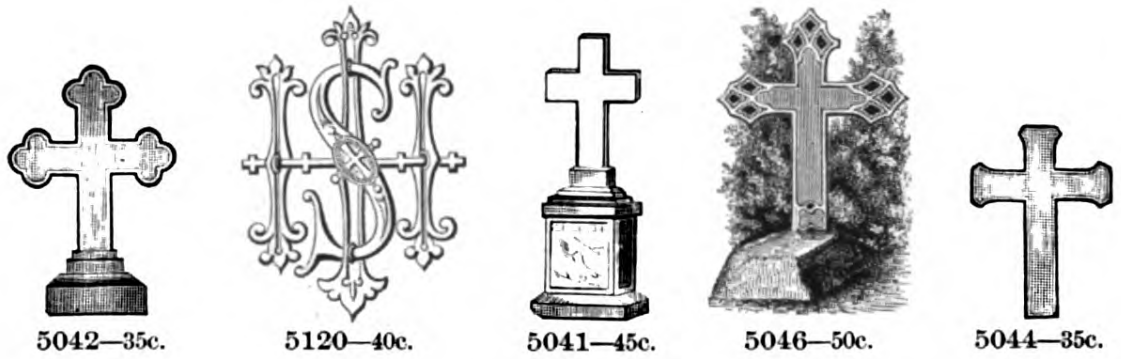
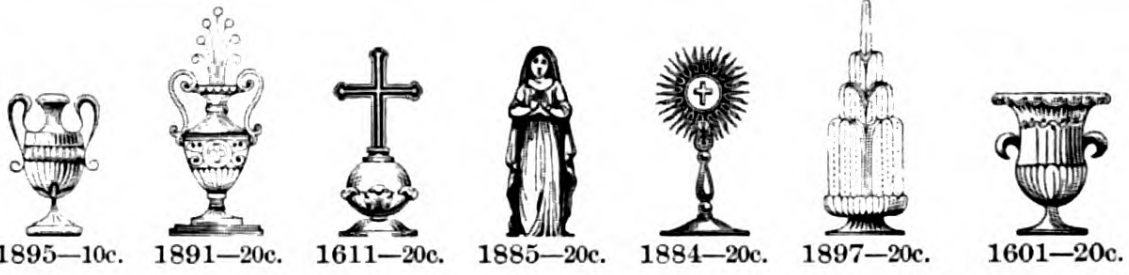

V. B. MUNSON, SUCCESSOR TO
GEO. BRUCE'S SON & CO., 13 CHAMBERS STREET, NEW YORK.

INDEX CUTS

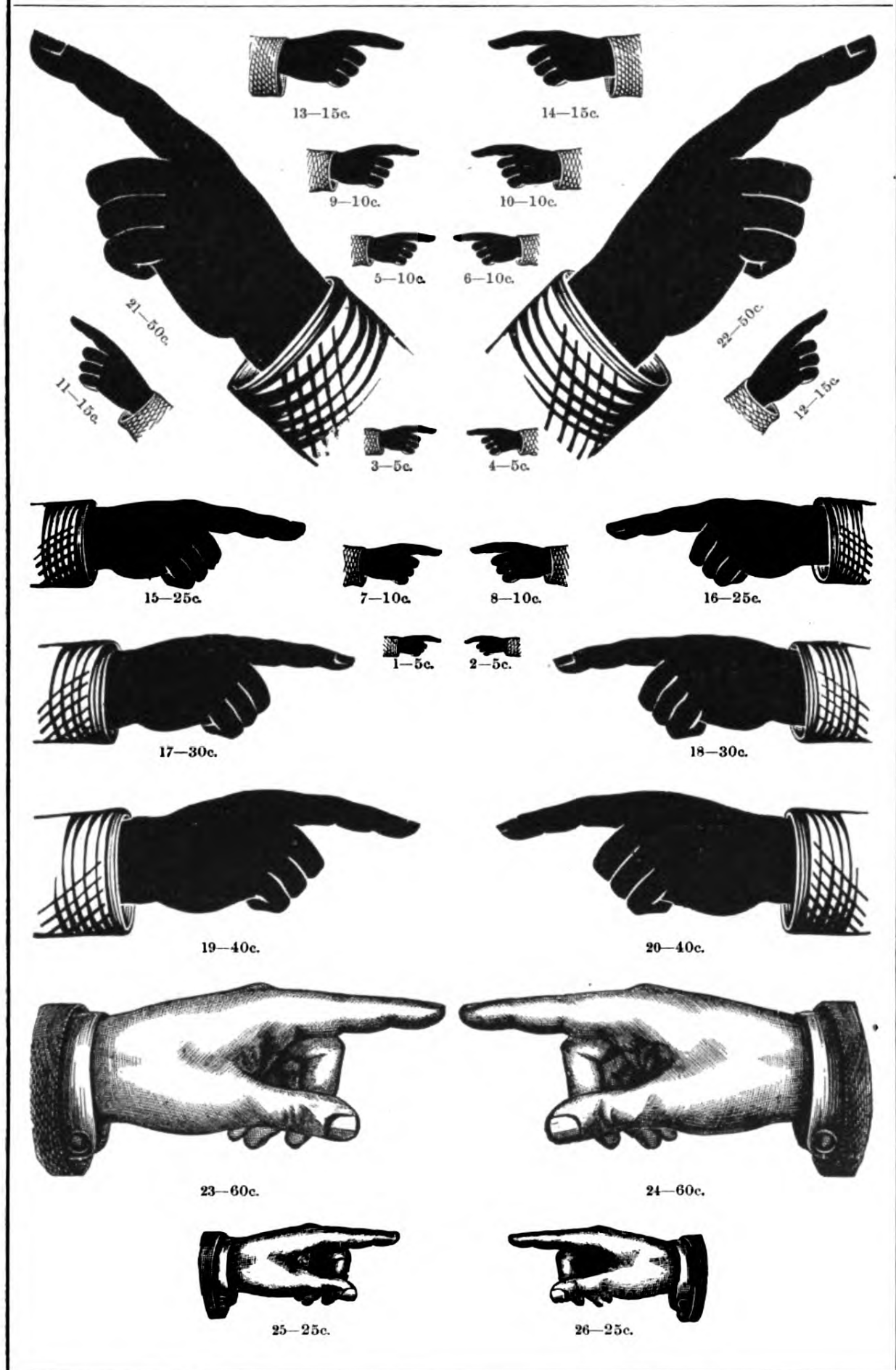

V. B. MUNSON, SUCCESSOR TO
 GEO. BRUCE'S SON & CO., 13 CHAMBERS STREET, NEW YORK.

ELECTROTYPE NEWSPAPER HEADINGS

48-POINT ROMAN, No. 13.

NO. 1.

9 CENTS PER LETTER.

NEW YORK LEDGER.

60-POINT ROMAN, No. 13.

NO. 2.

13 CENTS PER LETTER.

CROTON TIMES.

60 AND 80-POINT ITALIC, No. 13.

NO. 3.

14 CENTS PER LETTER.

THE GLOBE.

V. B. MUNSON, SUCCESSOR TO GEO. BRUCE'S SON & CO., 13 CHAMBERS STREET, NEW YORK.

ELECTROTYPE NEWSPAPER HEADINGS.

72-POINT BLACK OPEN, No. 501.

NO. 4.

12 CENTS PER LETTER.

The Morning Post.

72-POINT BLACK, No. 401.

NO. 5.

12 CENTS PER LETTER.

Durchaum Chronicle.

84-POINT MODERN TEXT OPEN, No. 511.

NO. 6.

15 CENTS PER LETTER.

Mail and Express.

V. B. MUNSON, SUCCESSOR TO GEO. BRUCE'S SON & CO., 13 CHAMBERS STREET, NEW YORK.

ELECTROTYPE NEWSPAPER HEADINGS

96-POINT BLACK OPEN, No. 509.

NO. 7.

16 CENTS PER LETTER.

Daily Enquirer.

448

96-POINT MODERN TEXT OPEN, No. 511.

NO. 8.

16 CENTS PER LETTER.

Daily Visitor.

V. B. MUNSON, SUCCESSOR TO GEO. BRUCE'S SON & CO., 13 CHAMBERS STREET, NEW YORK.

WOOD TYPE.

The series shown in this Specimen Book are selected from our Complete Specimen Book of Wood Type, which will be forwarded on application. It contains the most up-to-date, and also all the standard, styles of Wood Type, Borders and Ornaments.

Wood Type is priced by the letter, and sold in various sized fonts, as under. Font orders are subject to a liberal discount; small sort orders are subject to a smaller discount than is allowed on fonts. For prices and schemes of 4A and 5A fonts, see our Specimen Book of Wood Type.

- 3A cap font contains 75 letters.
- 3a lower-case font contains 65 letters.
- 4A cap font contains 106 letters.
- 4a lower-case font contains 90 letters.
- 5A cap font contains 120 letters.
- 5a lower-case font contains 104 letters.

Figures are put up separately.

Customers should bear in mind that End-Wood Type can be made any size desired. A wood-type letter increases in width in exactly the same proportion as it does in length. For example: If a 12-line letter is 2 inches wide, the same letter in 15-line will be 2½ inches wide, the increase being one-quarter each way.

Caps. 75 Letters	Lower Case 65 Letters	Figs. and Points.
A —3	a —3	1 —3
B —2	b —2	2 —2
C —2	c —2	3 —2
D —2	d —2	4 —2
E —4	e —4	5 —2
F —2	f —2	6 —2
G —2	g —2	7 —2
H —2	h —2	8 —2
I —4	i —3	9 —2
J —2	j —1	0 —5
K —1	k —1	\$ —2
L —4	l —4	! —2
M —2	m —2	. —3
N —3	n —3	: —1
O —3	o —3	; —1
P —2	p —2	— —2
Q —1	q —1	— —1
R —3	r —3	— —3
S —4	s —4	
T —3	t —4	
U —2	u —2	
V —2	v —2	
W —2	w —2	
X —1	x —1	
Y —2	y —2	
Z —1	z —1	
& —1	fi —1	
	fl —1	
	ff —1	
	fm —1	
	fn —1	

REVISED PRICE LIST PER LETTER.

This Price List Supersedes all Others Issued

The prices for all sizes of each style of type shown in this book can be found in this Revised Price List. The left-hand column gives the size of Type or lines Pica. The letters L, M, N, etc., at the top of table, give the class to which the letter belongs, and the figures in the different columns give the price per letter. The sizes of fonts are given above.

Always state whether CAPS alone are wanted, or CAPS and FIGURES, or CAPS, LOWER CASE and FIGURES, or CAPS and LOWER CASE, and how large a font or number of As.

Give full directions for shipping, unless it is desired to leave the matter to us, in which case we will ship the cheapest way, freight or express.

LINES PICA.	CLASSIFICATIONS.									
	L	M	N	O	P	Q	R	S	T	U
2-line	.06	.06	.06	.06	.06	.06	.08	.10	.13	.16
3-line	.06	.06	.06	.06	.06	.06	.08	.12	.15	.18
4-line	.06	.06	.06	.06	.06	.06	.08	.12	.15	.18
5-line	.06	.06	.06	.06	.07	.08	.09	.14	.17	.20
6-line	.06	.06	.06	.06	.08	.10	.11	.16	.19	.22
8-line	.08	.08	.08	.08	.10	.12	.13	.18	.22	.26
10-line	.09	.09	.10	.10	.12	.15	.16	.20	.25	.30
12-line	.10	.10	.12	.12	.14	.17	.18	.23	.28	.32
14-line	.11	.12	.13	.14	.16	.20	.22	.26	.30	.34
15-line	.12	.13	.14	.15	.18	.21	.24	.28	.32	.36
16-line	.12	.14	.15	.16	.19	.22	.25	.30	.34	.38
18-line	.13	.15	.17	.18	.21	.24	.28	.33	.37	.42
20-line	.14	.16	.18	.20	.24	.28	.32	.37	.40	.44
24-line	.17	.19	.22	.24	.28	.32	.36	.42	.45	.48
25-line	.18	.20	.23	.25	.30	.34	.38	.45	.48	.50
30-line	.21	.24	.27	.30	.35	.40	.44	.52	.55	.58
36-line	.28	.31	.34	.36	.41	.46	.50	.56	.59	.62
40-line	.33	.36	.38	.40	.45	.50	.56	.60	.63	.66
45-line	.36	.39	.42	.45	.50	.58	.63	.64	.67	.70
50-line	.45	.47	.48	.50	.56	.65	.70	.70	.72	.74
60-line	.50	.53	.56	.60	.66			.80	.83	.86
72-line	.60	.62	.64	.72	.78			.90	.95	1.00
80-line	.64	.66	.68	.80	.86			1.00	1.07	1.14
100-line	.75	.78	.80	1.00	1.06			1.15	1.25	1.35

All styles of Wood Type that are made can be furnished on receipt of sample at above prices, subject to liberal discount.

BRUCE TYPE FOUNDRY, 13 CHAMBERS STREET, NEW YORK.

WOOD TYPE.

WOOD RULE.

12 cents per yard on side-wood ; 15 cents per foot on end-wood—in assorted lengths. End-wood Rule cannot be supplied in yard lengths. Solid corners to match all sizes, 25 cents per set of four. Wood Rule is sold at a lesser discount than Wood Type.

STYLE W 24 POINT



STYLE U 18 POINT



STYLE R 12 POINT



STYLE N 8 POINT

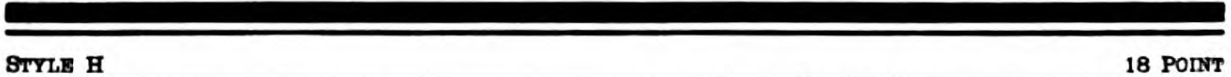

STYLE H 18 POINT



STYLE E 12 POINT

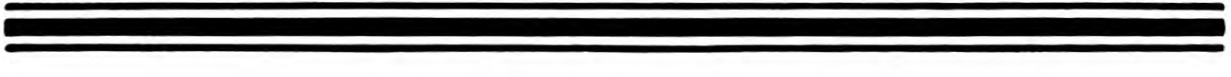

STAR RULE.

In fonts of 5 feet, with one set of Corners, \$1.90. Star Rule cannot be supplied in yard lengths.

No. 27



No. 23



No. 24



No. 20



WOOD POINTERS.

A set contains 25 pieces, matching those in our Metal Pointers.



2-line Pointers, per set, \$2.00	5-line Pointers, per set, \$3.50
3 " " " " 2.50	6 " " " " 4.00
4 " " " " 3.00	8 " " " " 5.00

For other styles of Wood and Star Rules, see our Complete Specimen Book of Wood Type. Sent on application only.

BRUCE TYPE FOUNDRY, 13 CHAMBERS STREET, NEW YORK.

WOOD TYPE.

END-WOOD BORDERS.

Kept in stock in 5-foot fonts, with one set of Corners. For a full sheet 10 feet of Border are required.

No. 244

5 FEET WITH CORNERS \$5 40



No. 333

5 FEET WITH CORNERS \$5 40

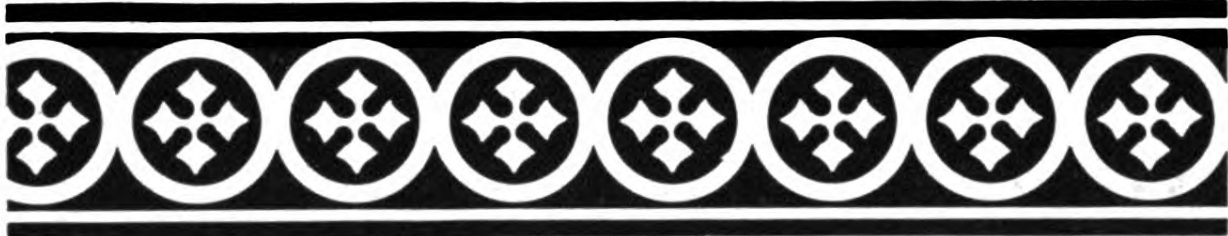

No. 131

5 FEET WITH CORNERS \$4 20



No. 295

5 FEET WITH CORNERS \$4 20



No. 110

5 FEET WITH CORNERS \$4 20



No. 254

5 FEET WITH CORNERS \$3 60



No. 259

5 FEET WITH CORNERS \$3 60



No. 250

5 FEET WITH CORNERS \$3 60



No. 40

5 FEET WITH CORNERS \$3 60



For a complete assortment of Wood Borders, see our Specimen Book of Wood Type. Sent on application only.

BRUCE TYPE FOUNDRY, 13 CHAMBERS STREET, NEW YORK.

WOOD TYPE.

CLASS P

NO. 641, 10-LINE

12 CENTS PER LETTER

Bands

CLASS P

NO. 641, 8-LINE

10 CENTS PER LETTER

Bradley

CLASS P

NO. 641, 6-LINE

8 CENTS PER LETTER

Founders 5

CLASS P

NO. 641, 5-LINE

7 CENTS PER LETTER

Predominate

For sizes of fonts and prices of other sizes of this series see page 449.
For specimens of other sizes see our Specimen Book of Wood Type, which is
sent only upon application. Lower case and figures made for all sizes.

BRUCE TYPE FOUNDRY, 13 CHAMBERS STREET, NEW YORK.

WOOD TYPE.

CLASS O

NO. 642, 10-LINE

10 CENTS PER LETTER

Great

CLASS O

NO. 642, 8-LINE

8 CENTS PER LETTER

Stands

CLASS O

NO. 642, 6-LINE

6 CENTS PER LETTER

Decorate

CLASS O

NO. 642, 5-LINE

6 CENTS PER LETTER

Establish 5

For sizes of fonts and prices of other sizes of this series see page 449. For specimens of other sizes see our Specimen Book of Wood Type, which is sent only upon application. Lower case and figures made for all sizes.

BRUCE TYPE FOUNDRY, 13 CHAMBERS STREET, NEW YORK.

WOOD TYPE.

CLASS O

NO. 627, 10-LINE

10 CENTS PER LETTER

Mad

CLASS O

NO. 627, 8-LINE

8 CENTS PER LETTER

Colts

CLASS O

NO. 627, 7-LINE

8 CENTS PER LETTER

Break

CLASS O

NO. 627, 6-LINE

6 CENTS PER LETTER

Grants

For sizes of fonts and prices of other sizes of this series see page 449.
For specimens of other sizes see our Specimen Book of Wood Type, which is
sent only upon application. Lower case and figures made for all sizes.

BRUCE TYPE FOUNDRY, 13 CHAMBERS STREET, NEW YORK.

WOOD TYPE.

CLASS O

NO. 629, 10-LINE

10 CENTS PER LETTER

Backs

CLASS O

NO. 629, 8-LINE

8 CENTS PER LETTER

Hunter

CLASS O

NO. 629, 6-LINE

6 CENTS PER LETTER

Exhibited

CLASS O

NO. 629, 5-LINE

6 CENTS PER LETTER

Celebration

For sizes of fonts and prices of other sizes of this series see page 449. For specimens of other sizes see our Specimen Book of Wood Type, which is sent only upon application. Lower case and figures made for all sizes.

BRUCE TYPE FOUNDRY, 13 CHAMBERS STREET, NEW YORK.

WOOD TYPE.

CLASS O

NO. 189, 10-LINE

10 CENTS PER LETTER

RIID

CLASS O

NO. 189, 8-LINE

8 CENTS PER LETTER

DOOG

CLASS O

NO. 189, 6-LINE

6 CENTS PER LETTER

Bands

CLASS O

NO. 189, 5-LINE

6 CENTS PER LETTER

Board 6

For sizes of fonts and prices of other sizes of this series see page 449.
For specimens of other sizes see our Specimen Book of Wood Type, which is
sent only upon application. Lower case and figures made for all sizes.

BRUCE TYPE FOUNDRY, 13 CHAMBERS STREET, NEW YORK.

WOOD TYPE.

CLASS N

NO. 95, 10-LINE

10 CENTS PER LETTER

ROUND HEADS

CLASS N

NO. 95, 8-LINE

8 CENTS PER LETTER

BOUNDING HORSE

CLASS N

NO. 95, 6-LINE

6 CENTS PER LETTER

DUTCHMAN BREECHES

CLASS N

NO. 95, 5-LINE

6 CENTS PER LETTER

Womens Beautiful Costumes

For sizes of fonts and prices of other sizes of this series see page 449. For specimens of other sizes see our Specimen Book of Wood Type, which is sent only upon application. Lower case and figures made for all sizes.

BRUCE TYPE FOUNDRY, 13 CHAMBERS STREET, NEW YORK.

WOOD TYPE.

CLASS N

NO. 24. 15-LINE

14 CENTS PER LETTER

ROBINS

CLASS N

NO. 24. 10-LINE

10 CENTS PER LETTER

POINTERS

CLASS N

NO. 24. 6-LINE

6 CENTS PER LETTER

NATIONAL SONGS

For sizes of fonts and prices of other sizes of this series see page 449. For specimens of other sizes see our Specimen Book of Wood Type, which is sent only upon application. Lower case and figures made for all sizes.

BRUCE TYPE FOUNDRY, 13 CHAMBERS STREET, NEW YORK.

WOOD TYPE.

CLASS N

NO. 37, 10-LINE

10 CENTS PER LETTER

HIDES

CLASS N

NO. 37, 8-LINE

8 CENTS PER LETTER

DESIGN

CLASS N

NO. 37, 6-LINE

6 CENTS PER LETTER

MOTHERS

CLASS N

NO. 37, 5-LINE

6 CENTS PER LETTER

Side Boards

For sizes of fonts and prices of other sizes of this series see page 449. For specimens of other sizes see our Specimen Book of Wood Type, which is sent only upon application. Lower case and figures made for all sizes.

BRUCE TYPE FOUNDRY, 13 CHAMBERS STREET, NEW YORK

WOOD TYPE.

CLASS O

NO. 23, 10-LINE

10 CENTS PER LETTER

DOOB

CLASS O

NO. 23, 8-LINE

8 CENTS PER LETTER

SUMM

CLASS O

NO. 23, 6-LINE

6 CENTS PER LETTER

CORES

CLASS O

NO. 23, 5-LINE

6 CENTS PER LETTER

MORNS

For sizes of fonts and prices of other sizes of this series see page 449. For specimens of other sizes see our Specimen Book of Wood Type, which is sent only upon application. Lower case and figures made for all sizes.

BRUCE TYPE FOUNDRY, 13 CHAMBERS STREET, NEW YORK.

WOOD TYPE.

CLASS L

NO. 81, 15-LINE

12 CENTS PER LETTER

SPRUCE

CLASS L

NO. 81, 10-LINE

9 CENTS PER LETTER

TIME RUNS

CLASS L

NO. 81, 6-LINE

6 CENTS PER LETTER

BRADENBURGH 8

For sizes of fonts and prices of other sizes of this series see page 449.
For specimens of other sizes see our Specimen Book of Wood Type, which is
sent only upon application. Lower case and figures made for all sizes.

BRUCE TYPE FOUNDRY, 13 CHAMBERS STREET, NEW YORK.

WOOD TYPE.

CLASS L

NO. 50, 10-LINE

9 CENTS PER LETTER

HOMER

CLASS L

NO. 50, 8-LINE

8 CENTS PER LETTER

GRINDER

CLASS L

NO. 50, 6-LINE

6 CENTS PER LETTER

NUMBERED

CLASS L

NO. 50, 5-LINE

6 CENTS PER LETTER

Government 4

For sizes of fonts and prices of other sizes of this series see page 449.
For specimens of other sizes see our Specimen Book of Wood Type, which is
sent only upon application. Lower case and figures made for all sizes.

BRUCE TYPE FOUNDRY, 13 CHAMBERS STREET, NEW YORK.

WOOD TYPE.

CLASS M

NO. 45 10-LINE

9 CENTS PER LETTER

RIDES

CLASS M

NO. 45. 8-LINE

8 CENTS PER LETTER

SHINER

CLASS M

NO. 45. 6-LINE

6 CENTS PER LETTER

GROUND

CLASS M

NO. 45. 5-LINE

6 CENTS PER LETTER

Numerate 5

For sizes of fonts and prices of other sizes of this series see page 449.
For specimens of other sizes see our Specimen Book of Wood Type, which is
sent only upon application. Lower case and figures made for all sizes.

BRUCE TYPE FOUNDRY, 13 CHAMBERS STREET, NEW YORK.

WOOD TYPE.

CLASS O

NO. 21, 10-LINE

10 CENTS PER LETTER

DOOG

CLASS O

NO. 21, 8-LINE

8 CENTS PER LETTER

RIMS

CLASS O

NO. 21, 6-LINE

6 CENTS PER LETTER

HOUSE

CLASS O

NO. 21, 5-LINE

6 CENTS PER LETTER

SPOKEN

For sizes of fonts and prices of other sizes of this series see page 449.
For specimens of other sizes see our Specimen Book of Wood Type, which is
sent only upon application. Lower case and figures made for all sizes.

BRUCE TYPE FOUNDRY, 13 CHAMBERS STREET, NEW YORK.

**Illustrated Catalogue and
Price List of Printing
Machinery and Supplies,
Wood Goods and Inks**



**EVERYTHING
FOR THE
PRINTER**

~ BRUCE TYPE FOUNDRY ~

No. 13 Chambers Street

NEW YORK

EVERYTHING FOR THE PRINTER.

PRINTERS' WOOD GOODS.

WOODEN MALLET.

Made of thoroughly seasoned and selected stock; handles screwed in; finished in oil; attractive shape. The lignumvitæ mallets can be specially recommended. They are heavier than hickory mallets, and wear like iron.

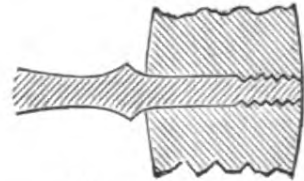

Shows Handle screwed in.

Hickory, small, 2½ × 4½ inches . . .	\$0 25	Lignumvitæ, 2¼ × 3½ inches	\$0 50
Hickory, medium, 3 × 5 inches	0 30	Lignumvitæ, 3 × 5 inches	0 60
Hickory, large, 3½ × 6 inches	0 40	Lignumvitæ, 3½ × 5½ inches	0 75
IRON BOUND WOODEN MALLET			1 00

PATENT RAWHIDE MALLET.

This mallet is made entirely of rolled rawhide, except handle, which is of wood.

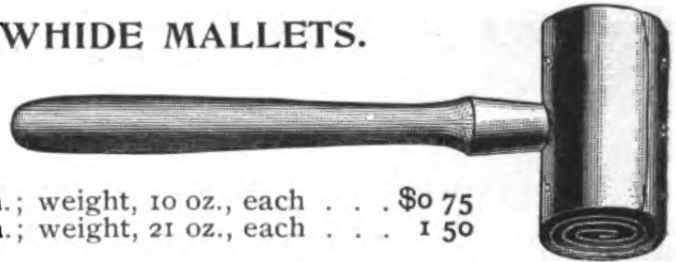

No. 4. Diameter, 2 in.; length, 3¼ in.; weight, 10 oz., each . . .	\$0 75
No. 5. Diameter, 2¾ in.; length, 4¼ in.; weight, 21 oz., each . . .	1 50

RAWHIDE BOUND MALLET.

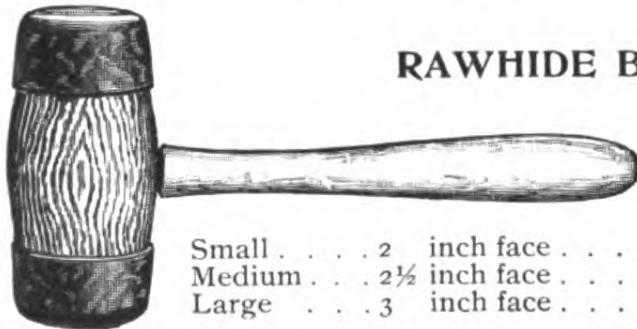

The most durable, finest finished, and hand-somest made. Positively will not split. The spring of the hide-facing cushions the blow and prevents jarring the muscles.

Small 2 inch face	\$0 60
Medium 2½ inch face	0 75
Large 3 inch face	1 00

PLANERS.

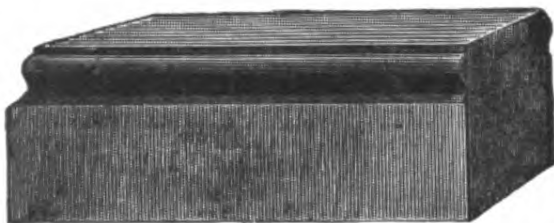

Maple, small, 3 × 6 inches	\$0 25
Maple, large, 3½ × 8 inches	0 30
Maple, leather top, 3½ × 8 inches	0 40

PROOF PLANERS.

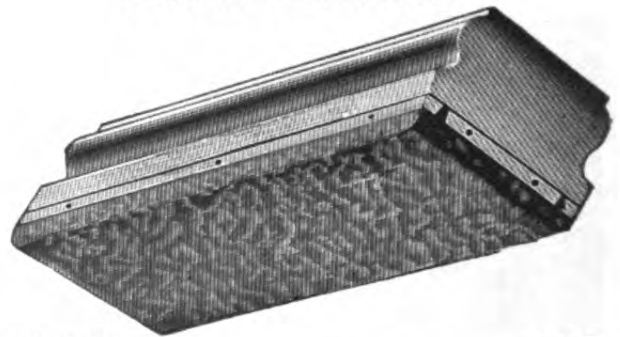

3½ × 8 inches	\$0 60
Piece Felt for recovering	0 30

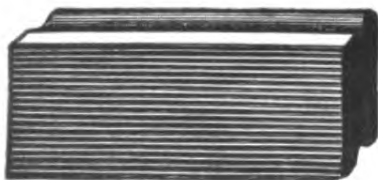

LINOTYPE PLANER.

The Linotype planer has a corrugated rubber face and is used for removing the burr from Linotype slugs.

Price, each	\$0 50
-----------------------	--------

EVERYTHING FOR THE PRINTER.

PRICE LIST OF CASES.

For illustrations of Cases, see pages 471 and 472.

PATENT NEW DEPARTURE TYPE CASES.

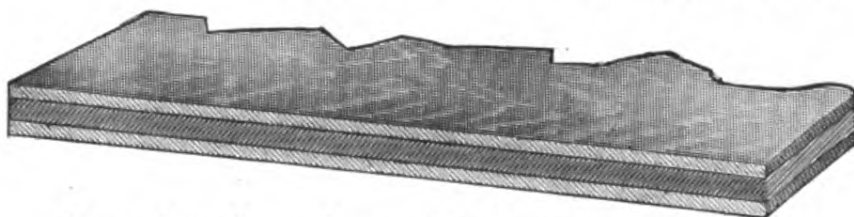

Shows three-ply case bottom, which will not warp nor crack.

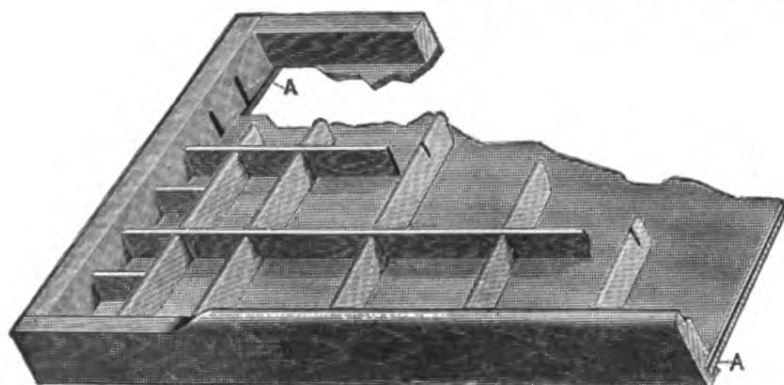

Shows at AA how the three-ply bottoms are set into the front and side rails, so that the case slides on the rails instead of on the case bottoms.

Our cases all have patent "New-Departure" three-ply bottoms, which prevent splitting, warping and shrinking. These bottoms are set into the side and front rails (see AA), so that the case slides on the side rails. As the grain of the side rails and of the case-runs in stands and cabinets run the same way, the cases slide much easier and with considerable less wear and tear.

FULL-SIZE CASES.

Size, $32\frac{1}{4} \times 16\frac{5}{8}$ inches.

	Clasp Cases.	Ordinary Cases.
News Cases, per pair	\$1 75	\$1 60
Cap Case	0 88	0 80
German News Cases, per pair	1 75	1 60
Italic or Job Case	1 00	0 90
California Job Case (see cut page 471)	1 00	0 90
Yankee Job Case—32 cap boxes—(see cut page 472)		1 00
Improved Job Case (see cut page 471)		1 20
Paterson Job Case (see cut page 471)		1 00
New York Job Case (see cut page 471)		1 00
Triple Case	1 00	0 90
Greek Cases (upper and lower), per pair	3 75	3 50
Music Cases (upper, lower and side), each	1 00	0 90
Double Lower Case (see cut page 471)		1 20
Rule Case		1 15
Space and Quad Case (see cut page 472)		1 00
Lead and Slug Case		1 00
Border Case		1 25
Figure Case		1 00
Metal Furniture Case (double depth), takes three layers of Furniture (see cut page 472)		2 00
Metal Furniture Case (single depth), takes two layers of Furniture (see cut page 472)		1 50
Blank Case		0 65
Wood Type No. 1 or Script Case, with bars (see page 472)		0 90

See also Special Wood-Type Cases listed on next page.

THREE-QUARTER CASES.

Size, $26\frac{1}{4} \times 16\frac{5}{8}$ inches.

News Cases, per pair	\$1 65	\$1 50
Cap Case	0 85	0 75
Italic or Job Case	0 95	0 85
California Job Case (see cut page 471)	0 95	0 85
Yankee Job Case—32 cap boxes—(see cut page 472)		0 85
Triple Case		0 85
Blank Case		0 60

BRUCE TYPE FOUNDRY, 13 CHAMBERS STREET, NEW YORK.

EVERYTHING FOR THE PRINTER.

TWO-THIRD CASES.

CAUTION.—There are two widths of two-third cases in use. If cases are required to fit stands already in use it is necessary, when ordering, to state exact width required, otherwise we will send our standard width, which is $21\frac{3}{4} \times 16\frac{5}{8}$ inches.

	Ordinary Cases.
New Cases, per pair	\$1 40
Job Case (thirty-two cap boxes)	0 75
Yankee Job Case (twenty-eight cap boxes)	0 75
California Job Case	0 75
Rule Case	0 90
Lead and Slug Case	0 75
Brass Leader Case	0 75
Script Case	0 75
Improved Job Case ($19\frac{3}{4}$ inches). Is deeper than the regular case, and has additional boxes for small caps	0 90
Border Case	0 90
Blank Case	0 45

ROOKER CASES.

A popular size for newspaper offices. Furnished to order only. Size, $28\frac{1}{2} \times 14$ inches over all.

	Patent Clasps.
News Cases, per pair	\$1 75
Italic or Job Case	1 00
California Job Case	1 00

SPECIAL CASES.

	Ordinary Cases.
Wood-Type Case No. 1 ($16\frac{5}{8} \times 32\frac{1}{4}$ inches)	\$0 90
Wood-Type Case No. 2 ($23 \times 32\frac{1}{4}$ inches)	1 00
Mammoth Wood-Type Case No. 3 (23×44 inches)	1 30
Wisconsin Combination "Quarter" Cases, Nos. A, B, C, D, for holding piece fractions, signs, fractions, figures and borders (see cut page 470), each	0 65

RULE CASES.

Regular Rule Case, full-size	\$1 15
Regular Rule Case, two-third size (see note at top of page)	0 90
Compact Rule Case. Four of them fit in a full-size blank case (see page 469), each	0 90
* Harris Rule Case, No. 1, holds two 8-pound fonts	1 25
* Harris Rule Case, No. 2, holds one 16-pound font	1 00
* Harris Rule Case, No. 3, } used together, hold one 32-pound font	0 75
* Harris Rule Case, No. 4, }	1 00
Full-size Blank Case, to hold four Harris Rule Cases	0 65

* See cut and description, page 469.

PATENT CLASP CASES.

These cases are of unusual strength, owing to the use of a brass clasp over the corner of each box and a long pin which is driven through center of each clasp and clinched, holding the partitions firmly to the bottom of the case. This feature, in combination with our "New-Departure"-case bottoms, makes these cases the strongest and most durable, especially for body type and in newspaper offices.

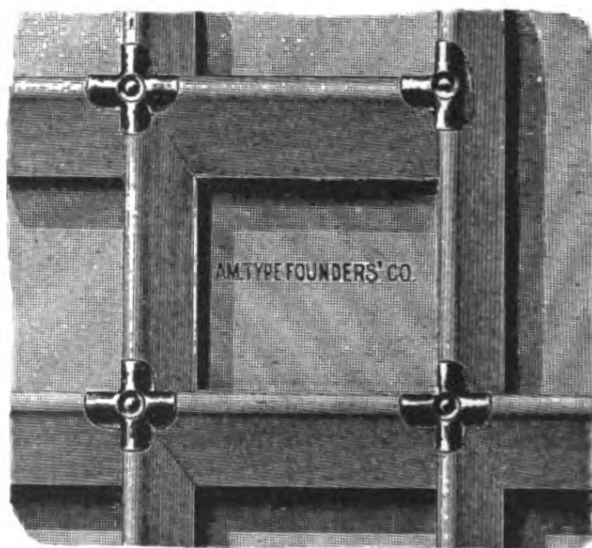

Section of Patent Clasp Case.

EVERYTHING FOR THE PRINTER.

HARRIS RULE CASES.

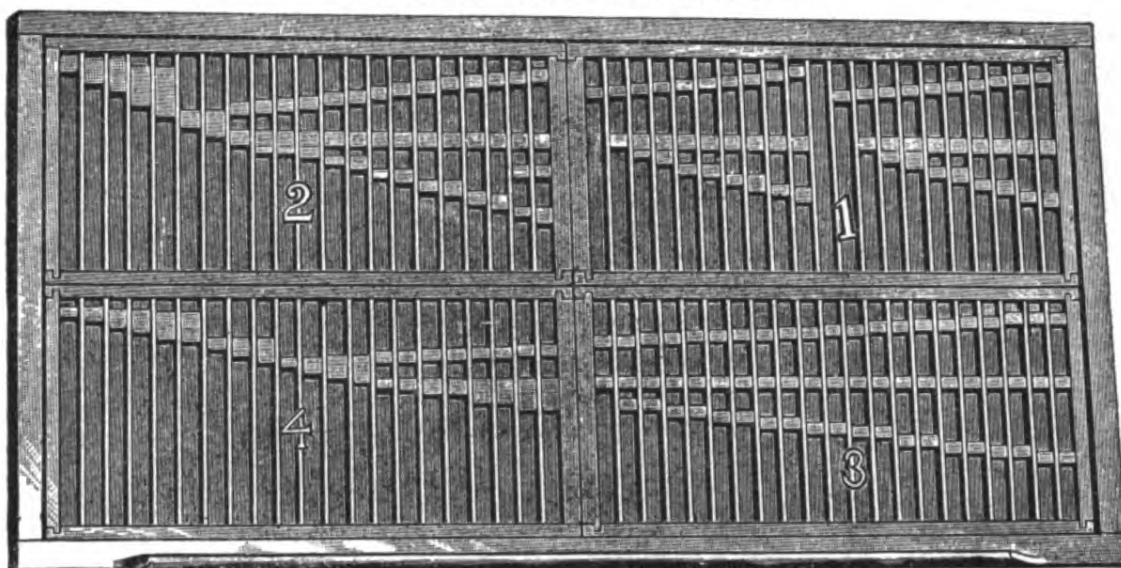

Four Harris Rule Cases in a Full-size Blank Case. Price, \$4 65.

In HARRIS RULE CASES the rule cannot fall flat—must always stay on end. Pi is prevented, because each box is accurately adjusted for its special size—for instance, a 21-em rule will not go into the 20-em rule box. Generous provision is made for the smaller sizes—the most valuable sizes in a labor-saving font. The cases may be used in sets or separately, as Nos. 1 and 2 are complete in themselves. Four of them fit into a full-size blank case.

The rule referred to below is 2-point, which is the most used.

No. 1 Harris Rule Case holds two complete small fonts of Labor Saving Rule, each weighing 8 pounds, or 16 pounds in all. Each half of this case holds eighteen pieces each length from 1 to 8½ ems (varying by ens), and eighteen pieces each from 9 to 18 ems (varying by ems) and nine pieces each 19, 20, 21, 22, 24, 26 and 28 ems, besides boxes for right and left miters.

No. 2 Harris Rule Case holds one complete font of 16 pounds weight or less. It has compartments for thirty-six pieces each from 1 to 9 ems long (varying by ens), eighteen pieces each from 10 to 24 ems long (varying by ems), and eighteen pieces each of 26, 28, 30, 32, 34, 36 ems long, besides boxes for right and left miters. A large proportion of small lengths allowed for.

Nos. 3 and 4 Harris Rule Cases are designed to be used together to hold a font of rule suitable for a large office, weighing 32 pounds or less. Two and in some cases four boxes are used to hold the most-used sizes. Each case has its proportion of the small sizes, so that if it is desired to carry one case to a compositor's stand for use in rule work, the other is available in its regular place with a good working font. These cases have compartments for seventy-two pieces each from 1 to 9 ems long (varying by ens), thirty-six pieces each from 10 to 24 ems long (varying by ems), and eighteen pieces each from 25 to 36 ems long (varying by ems), and boxes for right and left miters.

Harris Rule Case No. 1, holds two 8-pound fonts	\$1 25
Harris Rule Case No. 2, holds one 16-pound font	1 00
Harris Rule Case No. 3, } used together, hold one 32-pound font {	0 75
Harris Rule Case No. 4, }	1 00
Full-size Blank Case, to hold four of above	0 65

COMPACT RULE CASE.

Has compartments for brass rule from 1 to 36 ems Pica, and from 1½ to 9½ ems Pica, with places for miters. Size outside, 7¾ × 15¼ inches. Four fit in a full-size blank case. For Full-size Rule Cases see page 468.

Price \$0 90

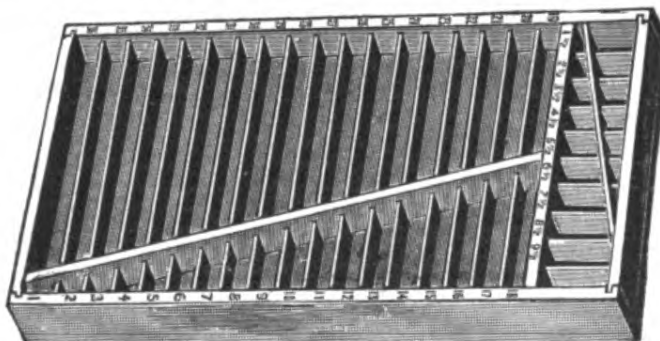

BRUCE TYPE FOUNDRY, 13 CHAMBERS STREET, NEW YORK.

EVERYTHING FOR THE PRINTER.

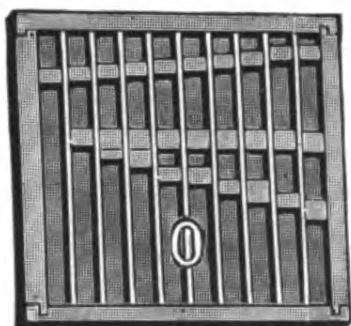

INDIVIDUAL LEAD OR RULE CASE.

In this a compositor may keep his much valued 12-to-Pica and other thicknesses of leads for justifying purposes, his pickups of dashes, rule, etc. The case can be kept in his drawer or on his galley rest. It has boxes from 1 to 9½ ems (varying by ens), from 10 to 22 ems (varying by ems), and from 22 to 28 ems (varying by two ems), with a long box for longer lengths. It is also useful for holding a small font of labor-saving brass rule.

Each, 7×7½ inches over all \$0 75

LEADER BOX.

The handiest receptacle for leaders. Can be put on a cap case, on a stone, or on a galley rest, bringing leaders close to hand. One or more required in every office for every size of body type used.

Each, 5×8×1¼ inches over all . . . \$0 25
Per dozen 2 50



WISCONSIN COMBINATION "QUARTER" CASES.

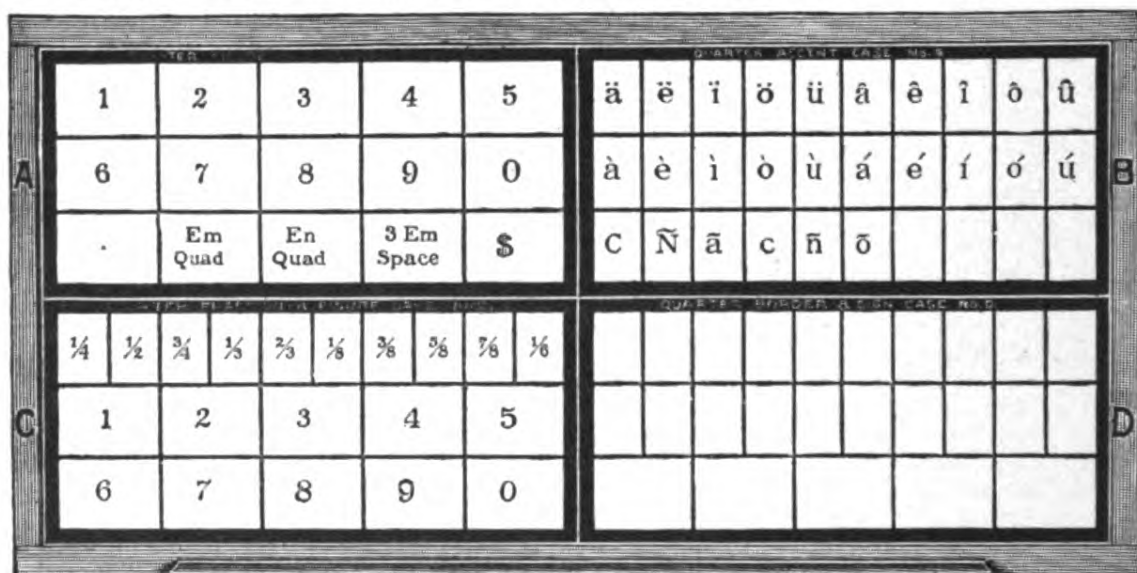

Shows four "Quarter" Cases in Full-size Blank Case.

Signs, borders, accents, split fractions, although most expensive, are usually stowed away in odd boxes of cap cases, and are rarely to be found when needed. "Quarter" Cases supply a means of keeping these valuable sorts where they can be found. They can be placed on a cap case, on a stand, or on the stone, convenient to hand of compositor. In setting mathematical work, foreign languages, dictionaries, and special catalogues, these "Quarter" Cases will prove invaluable. We show a few schemes for laying signs, fractions, etc., but various other uses for special purposes will suggest themselves to the "intelligent compositor."



For Split Fractions and Commercial Signs.



For Algebraic and Medical Signs.

- Quarter Case No. A, for Figures, etc. \$0 65
- Quarter Case No. B, for Accents, Split Fractions, etc. 0 65
- Quarter Case No. C, for Figures, Fractions, etc. 0 65
- Quarter Case No. D, for Signs, Borders, etc. 0 65
- Per set of four, in regular Full-size Blank Case 3 00

BRUCE TYPE FOUNDRY, 13 CHAMBERS STREET, NEW YORK.

EVERYTHING FOR THE PRINTER.

ILLUSTRATIONS OF CASES.

It is unnecessary to illustrate the most-used styles of cases. Nearly all the cases illustrated here have exceptional merit.

CALIFORNIA JOB CASE.

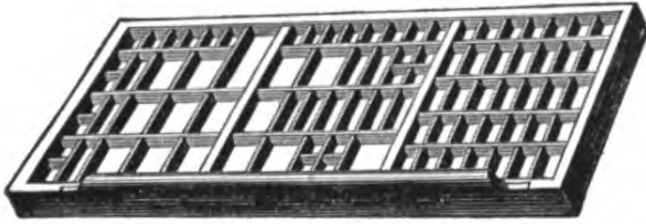

See "lay-out" on page 473

Has fourteen boxes less on cap side than the regular italic job case, thus giving more space for the cap alphabet. A more satisfactory case for the ordinary job font than the italic job case, especially in three-quarter size.

Full-size \$0 90
Three-quarter 0 85

IMPROVED JOB CASE.

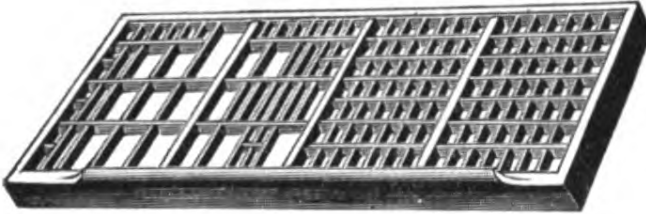

Holds caps, small caps, lower case and figures, or a cap and lower-case font (with figures) and an extra cap font. Will also hold three cap fonts, all with figures. Made full-size only.

Price \$1 20

NEW YORK JOB CASE.

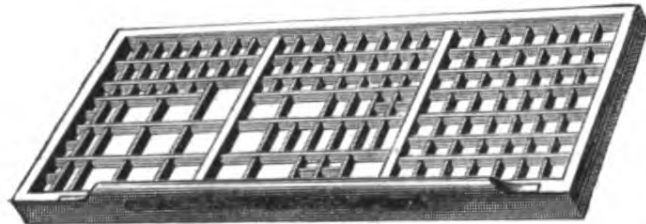

Holds caps, small caps, lower case and figures. The small caps are placed on the same side as the lower-case boxes, and above them. The lower-case boxes are therefore smaller than in a California job case. Made full-size only.

Price \$1 00

PATERSON JOB CASE.

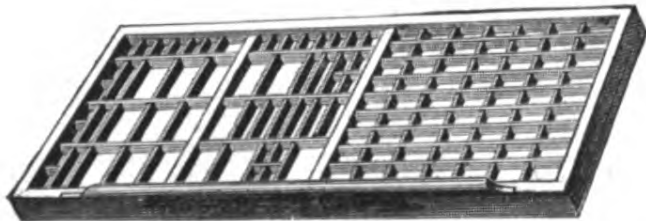

Holds caps, small caps, lower case and figures. The small caps are placed above the cap boxes, all of which are widened, thereby reducing the sizes of the lower-case boxes. A very useful case. Made full-size only.

Price \$1 00

DOUBLE LOWER CASE.

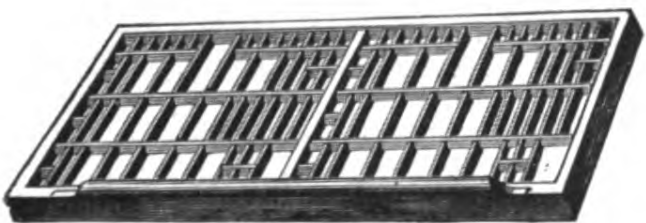

A most useful case. In most job fonts the caps occupy as much space as the lower case, while ordinary job cases give the caps one-half the room allotted the lower-case. In this case the space is divided equally between the caps and lower case. Made full-size only.

Price \$1 20

ROOKER CAP CASE.

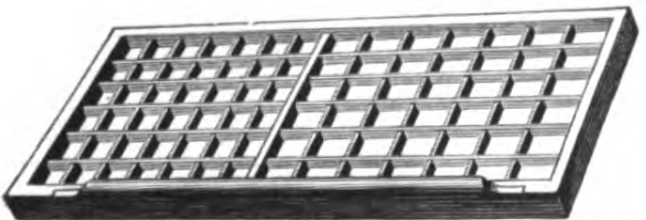

Made only in Rooker size ($28\frac{1}{4} \times 14\frac{1}{4}$). Gives more space for caps and less for small caps than the regular cap case. Rooker cases are two inches narrower than ordinary cases, and cannot be used on the same stands.

Price \$0 88

BRUCE TYPE FOUNDRY, 13 CHAMBERS STREET, NEW YORK.

EVERYTHING FOR THE PRINTER.

ILLUSTRATIONS OF CASES.

YANKEE JOB CASE.

In two-third size, a case with cap boxes at the back is a necessity, but in full-size and three-quarter size this case is inferior in utility to other job cases.

Full-size (32 cap boxes) \$1 00
 Three-quarter (32 cap boxes) 0 85
 Two-third (28 cap boxes) 0 75

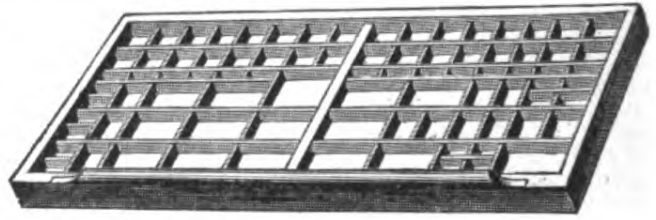

SPACE AND QUAD CASE.

This is an absolutely essential case in offices where economy of time and material is a consideration. Each case holds eight sizes of spaces and quads. Made full-size only.

Price \$1 00

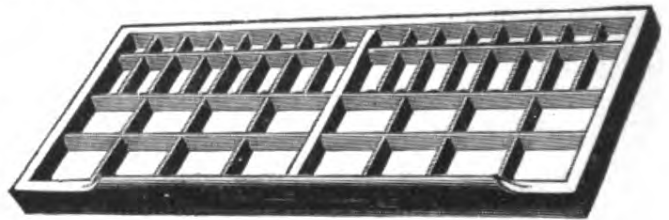

METAL FURNITURE CASE.

A handy receptacle for metal furniture. There are compartments for 1, 2, 3, 4, 5, 6, 8, 10, 15, 20, 25 and 50 ems. The double-depth case takes three layers of furniture; the single-depth case takes two layers. The latter can be put in a full-size case stand or rack, and the double-depth case is for use on top of a stand or cabinet, or a special place can be made for it under the stone. Made full-size only.

Double-depth \$2 00
 Single-depth 1 50

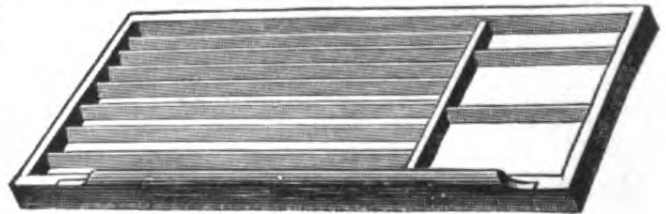

SCRIPT OR WOOD-TYPE CASE.

Although mostly sold for wood type, these cases are made so accurately as to be suitable for large script fonts. The movable partitions are adjustable by Picas. Nothing injures expensive script type so much as tumbling about in a case. The use of script cases will save type. Made in full- and two-third sizes.

Full-size \$0 90
 Two-third size 0 75

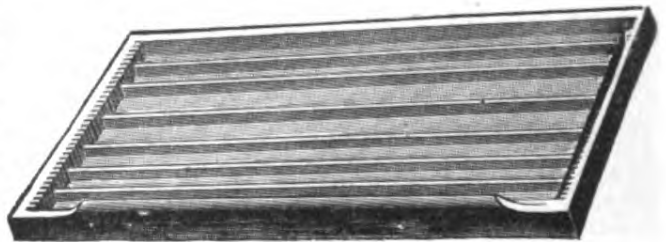

MAMMOTH WOOD-TYPE CASE.

No. 3 (Mammoth) Wood-Type Case, 23x44 inches, with slotted sides. For special rack to hold this size case, see page 474. There are two more sizes of wood-type cases made. For prices see page 468.

Price of No. 3 Wood-Type Case . . . \$1 30

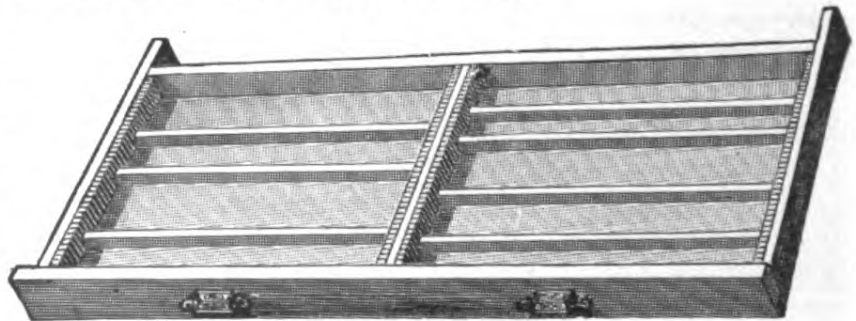

BRUCE TYPE FOUNDRY, 13 CHAMBERS STREET, NEW YORK.

EVERYTHING FOR THE PRINTER.

CASE STANDS.

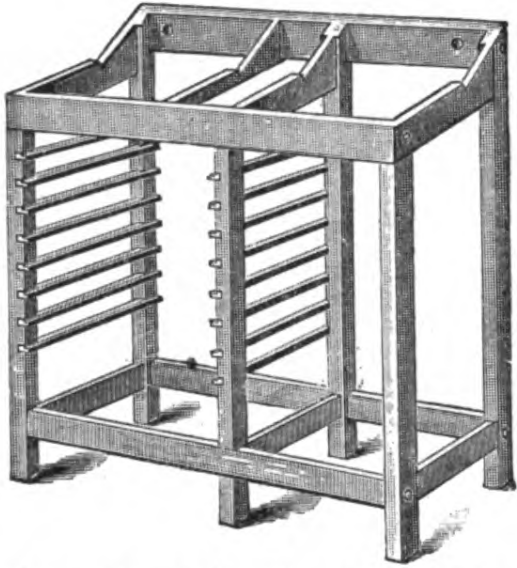

No. 6. Double News Stand, with Eight Racks.

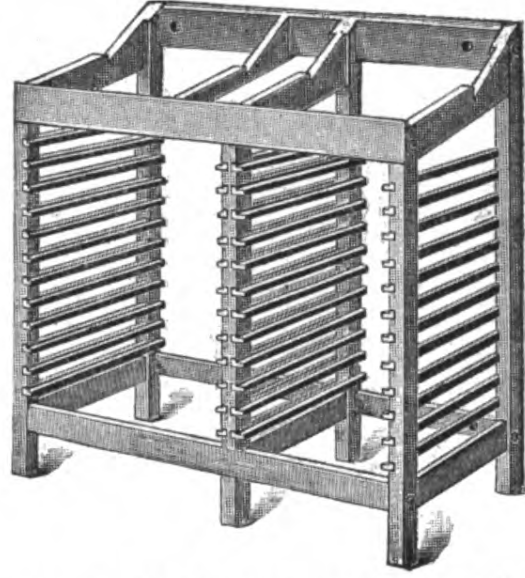

No. 11. Double Job Stand, with Racks for Twelve Full-size and Twelve Two-third Cases.

PRICE LIST OF CASE STANDS.

No. 1.	Single, without racks	\$2 75
No. 2.*	Single, with racks for 12 two-third cases	3 00
No. 2½	Single, with racks for 12 three-quarter cases	3 00
No. 4.	Single, with racks for 12 full-size cases	3 25
No. 6.	Double News, with racks for 8 full-size cases (see illustration)	3 75
No. 8.	Double News, with racks for 12 full-size cases	4 75
No. 11.*	Double Job Stand, with racks for 12 full-size and 12 two-third cases (see illustration)	5 50
No. 12.	Double Job Stand, with racks for 12 full-size and 12 three-quarter cases	5 75
No. 15.	Double Stand, with Galley Rest, and racks for 24 full-size cases (see illustration)	6 00
No. 17.	Double City Stand, with racks for 30 full-size cases (see illustration)	8 00

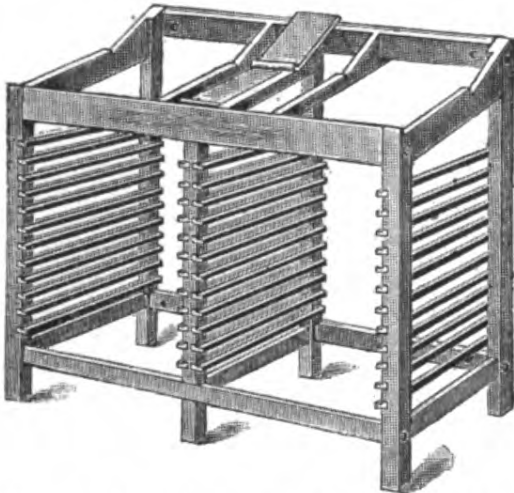

No. 15. Double Stand, with Galley Rest, and Racks for Twenty-four Full-size Cases.

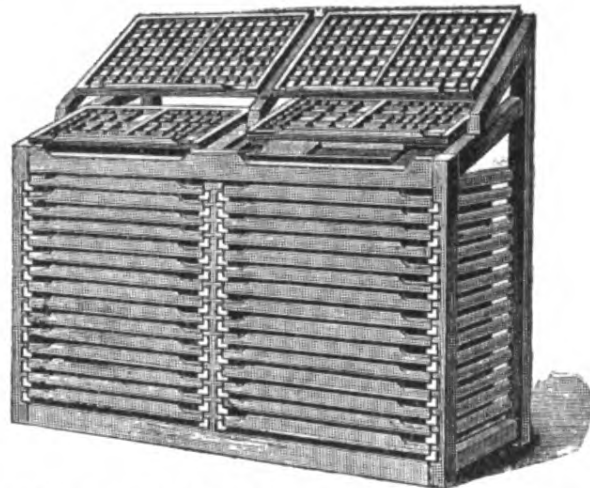

No. 17. Double City Stand. The upper cases project over the lower, bringing the caps nearer the hand. There is a shelf to hold a galley under the lower case, which can be pushed back to permit matter to be emptied on the galley.

**CAUTION.—There are two widths of two-third cases in use. In ordering it is necessary to state exact width of two-third case the stand is required to hold, otherwise we will send stands to take in our standard width of two-third cases.*

NEW YORK SPACE-SAVING CASE STANDS.



New York Double Stand.



New York Quadruple Stand (see end view below).

These are *space-saving, vent-reducing stands*. Two New York Double Stands, holding sixty cases in racks and four pairs cases on top, occupy eighteen square feet of floor space, as against thirty square feet occupied by two ordinary double stands, holding at most forty-eight cases in racks and four pairs cases on top—a saving of twelve square feet. Two Double City Stands occupy a floor space of twenty-five square feet as against seventeen feet occupied by one Quadruple New York Stand—a saving of eight square feet. This saving is obtained by making the racks correspond to size of cases exactly, bringing forward the cap cases so that they do not overhang at the back of stand (as they do on ordinary stands), and extending the lower cases several inches into the alley.



End view of New York Window and Quadruple Stands.

OTHER POINTS OF SUPERIORITY.

The lower cases project into the alley several inches, affording the compositor ample leg room, and allowing him to get closer to the type. The angle of the lower case is just right for rapid setting. The upper case is raised above the lower, and brought forward closer to the compositor's hand, while not obstructing the figure boxes of the lower case. The cases are held on strong iron brackets, securely screwed to a hard-wood top, which is perfectly smooth, and very useful for storing tied-up matter or for other purposes.

The Window Stand is a rearrangement of the Double Stand, so that it occupies a square area, and is very suitable for placing opposite a window.

New York Single Stand, with racks for 15 cases	\$ 6 50
New York Double Stand, with racks for 30 cases	10 50
New York Quadruple Stand, with racks for 60 cases	18 00
New York Window Stand, with racks for 30 cases	10 50

CASE RACKS.

Made of hard wood, bolted together, and the higher racks are braced at the center with iron rods to prevent spreading.

Full-size Cases.	Height.	
Single, to hold 10 cases	38 inches	\$ 5 50
Single, to hold 16 cases	50 inches	7 00
Single, to hold 20 cases	60 inches	8 00
Single, to hold 24 cases	70 inches	9 00
Single, to hold 30 cases	84 inches	10 00
Double, to hold 40 cases	60 inches	14 00
Double, to hold 60 cases	84 inches	18 00

Made to hold two-third and three-quarter cases at same prices. In ordering for two-third cases it is necessary to state exact width of cases, as there are two widths of two-third cases in use.

WOOD-TYPE CASE RACK.

Single, to hold 20 No. 3 Wood-Type Cases	\$9 00
A No. 3 Wood-Type Case is 23 x 44 inches over all.	

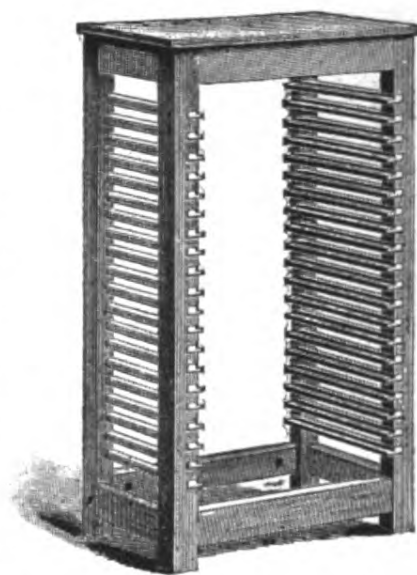

Case Rack for Twenty Full-size Cases.

EVERYTHING FOR THE PRINTER.

“AMERICAN-POLHEMUS” CABINETS.

All Hard Wood.

The object of the American-Polhemus Cabinet is to save time and space. Time is lost on the ordinary cabinets by stationing the compositor in front of twenty cases, all frequently in use by other men, who, when setting or distributing from them, keep the man at the cabinet idle. On the American-Polhemus Cabinets the job cases are unobstructed, and the compositor stands at the back, where he cannot be interrupted. If he is setting solid matter he can empty his sticks, without walking a step, on a galley kept under his lower case, as the cases are held by the Patent Tilting Bracket and Galley Rest. Illustrated on page 477.

Every inch of space on the American-Polhemus Cabinets is utilized to advantage. The galley top or bank is a most useful addition. The space between the cases is used as a sort of a galley cabinet. The top is flat, and tied-up matter may be kept on it, as the iron case brackets admit of easy access to the space under the cases and galley top. The brackets which hold the cases project into the alley eight inches, giving the compositor plenty of knee-room, while saving floor-space.

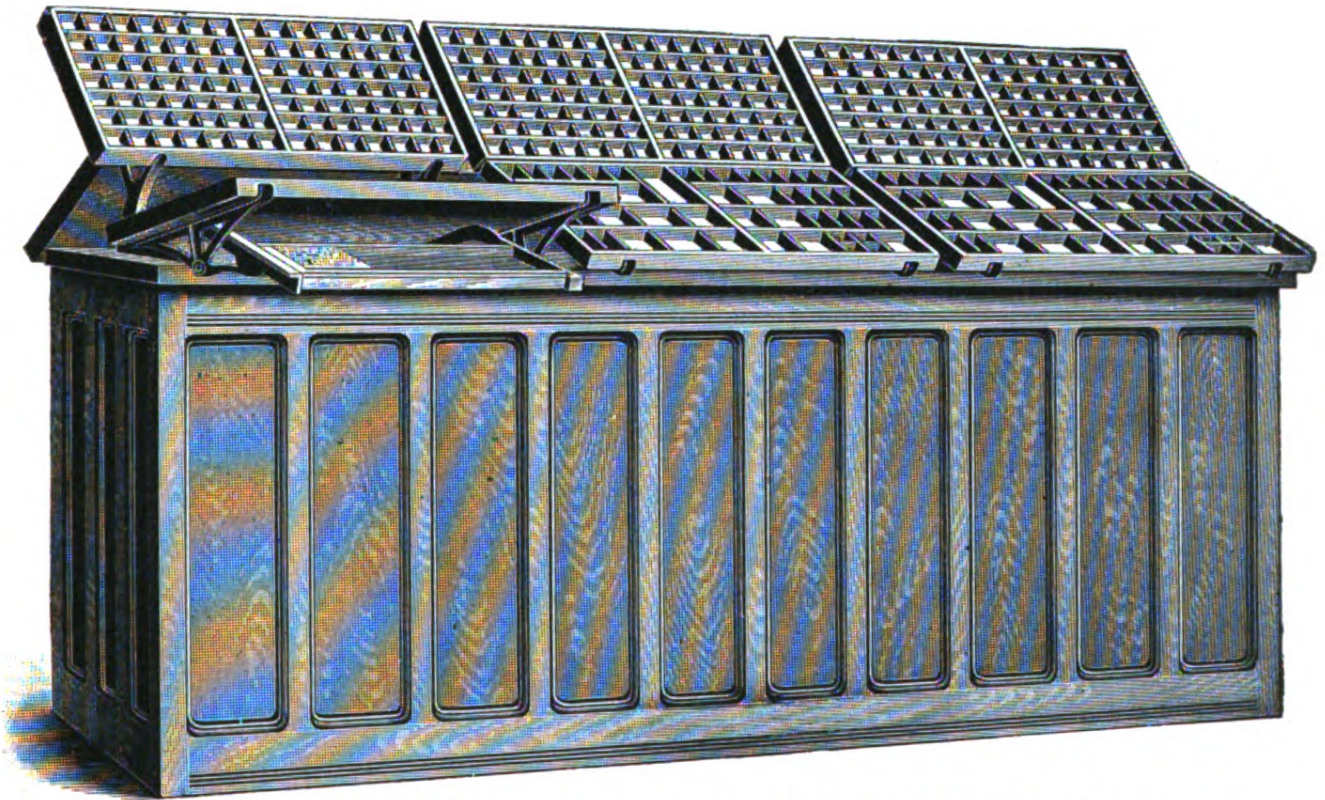

Back of American-Polhemus Triple Cabinet, showing arrangement of Body-letter Cases on the Patent Tilting Brackets.

PRICES OF AMERICAN-POLHEMUS CABINETS.

- No. 2. Single American-Polhemus Cabinet—Complete with 18 full-size California job cases, 1 pair of news cases, galley top, and 1 pair of patent tilting brackets \$35 00
- No. 1. Double American-Polhemus Cabinet—Complete with 18 full-size California and 20 two-third job cases, 2 pairs of news cases, galley top, 10 sort drawers or galley cabinet, and 2 pairs of patent tilting brackets 75 00
- No. 3. Triple American-Polhemus Cabinet—Complete with 18 full-size California and 40 two-third job cases (20 in a tier), 3 pairs news cases, galley top, 10 sort drawers and galley cabinet, and 3 pairs of patent tilting brackets . . . 110 00

BRUCE TYPE FOUNDRY, 13 CHAMBERS STREET, NEW YORK.

EVERYTHING FOR THE PRINTER.

STEEL-RUN AMERICAN-POLHEMUS CABINETS.

All Hard Wood.

These cabinets are similar to the American-Polhemus Cabinets, illustrated on these pages, except that the use of steel runs instead of wood runs increases their case-holding capacity without changing floor space or height.

- No. 4. Triple Polhemus Cabinets—Complete with 50 two-third and 25 full-size California job cases in three tiers (25 in a tier), 3 pairs news cases, galley top, 10 sort drawers and galley cabinet, and three pairs of patent tilting brackets. \$140 00
- No. 5. Double American-Polhemus Cabinet—Contains 25 full-size California job, 25 two-third job, and 2 pairs of full-size news cases on top, 10 sort drawers or galley cabinet, a galley top, and 2 pairs of patent tilting brackets 95 00
- No. 6. Double American-Polhemus Cabinet—Contains 50 full-size California job (25 in a tier), and 2 pairs of full-size news cases on top, a galley top, and 2 pairs of patent tilting brackets (*without sort drawers or galley cabinet*) . . . 95 00
- No. 7. Single American-Polhemus Cabinet—Contains 25 full-size California job, 1 pair of full-size news cases on top, a galley top, and 1 pair of patent tilting brackets 47 00

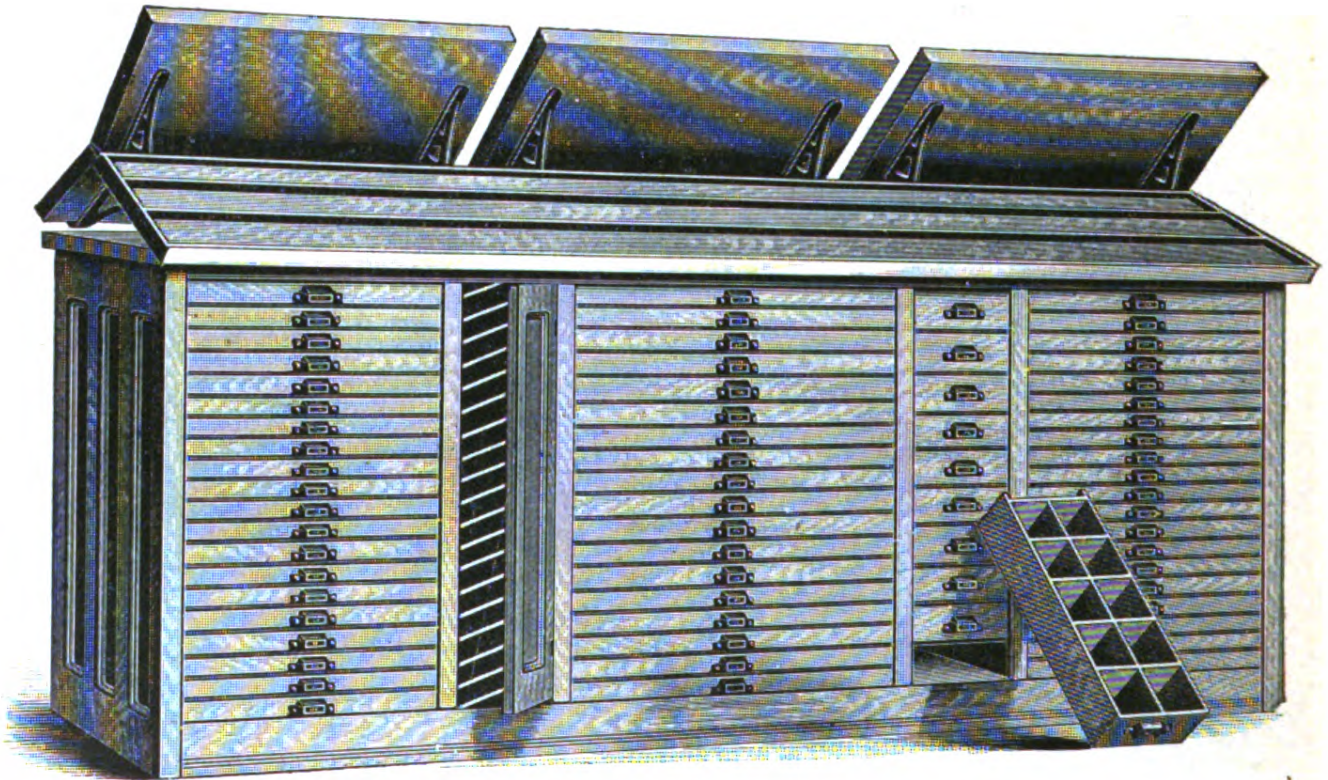

Front view of No. 3 Triple Polhemus Cabinet, showing Jobbing Cases, Sort Drawers, Galley Cabinet, and Galley Top on Bank.

CHOICE OF CASES.

Full-size California and two-third job cases will be furnished unless otherwise specified. Triple, regular job or italic, cap or lower cases, can be furnished, if desired, at the same prices. If rule, border or script cases are ordered, the difference in cost of cases will be added to the list price.

In ordering Double Polhemus Cabinets Nos. 1 and 5 be sure and state which you prefer—sort drawers or galley cabinet.

Cabinets are constructed of ash, with antique oak finish.

BRUCE TYPE FOUNDRY, 13 CHAMBERS STREET, NEW YORK.

EVERYTHING FOR THE PRINTER.

WISCONSIN WINDOW CABINET.

All Hard Wood.



Specially designed for placing in front of a window, as it does not obstruct the light, of which the cases on top get the full benefit. Two men may work undisturbed at the sides, while the job cases in front are convenient for other men. The top is flat, and useful for holding tied-up type.

These cabinets have the patent tilting bracket and galley rest, which enables a compositor to empty his stick without leaving the cabinet by simply tilting his lower case, as shown in the cut, thus exposing the galley.

Weight, crated, about 375 pounds. Width, 35 3/4 inches; height, 44 inches; depth, 20 3/8 inches.

No. 1. Wisconsin Window Cabinet, with 2 pairs of patent tilting brackets, 18 full-size California job cases, and 2 pairs of news cases on top \$36 00

No. 2. Wisconsin Window Cabinet, with 2 pairs of patent tilting brackets, 23 full-size cases and steel runs, and 2 pairs of news cases on top, same height as No. 1, 47 00

PATENT TILTING CASE BRACKET.

Used on Wisconsin Window and American-Polhemus Cabinets.

B B (outline) shows bracket holding case in position for setting. Shaded cut shows bracket tilted up, allowing compositor to empty on galley below lower case, which is more clearly shown in cut of Wisconsin Window Cabinet printed above. These brackets are also supplied with all American-Polhemus Cabinets.

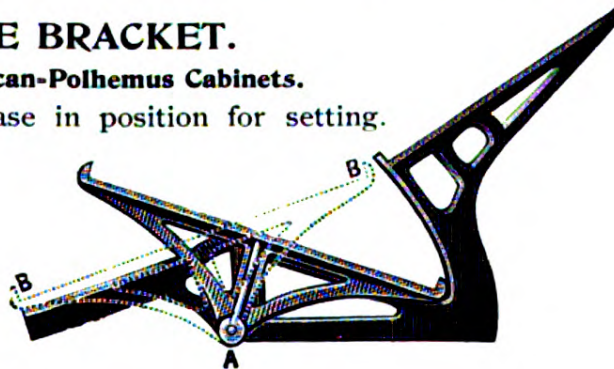

Per pair \$2 00

BRUCE TYPE FOUNDRY, 13 CHAMBERS STREET, NEW YORK.

EVERYTHING FOR THE PRINTER.

WISCONSIN HARD-WOOD CABINETS

With "New Departure" Cases.

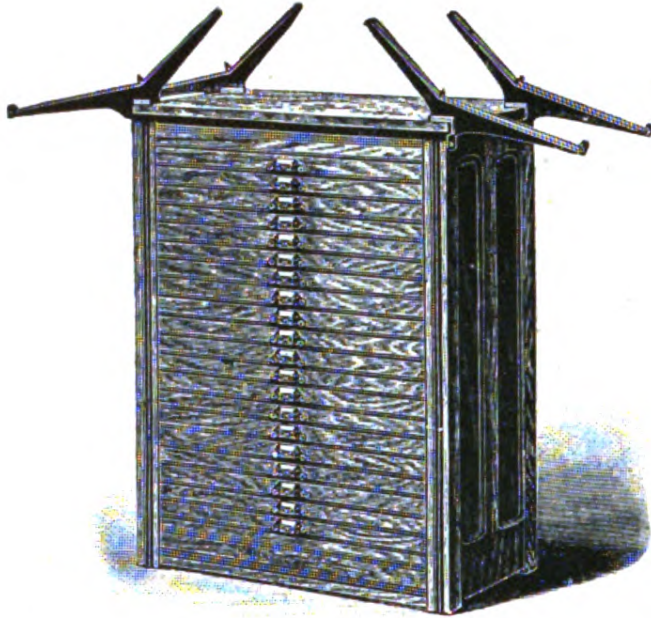

Twenty-Case Wisconsin Cabinet with Flat Top, showing Double Case Bracket, Style A, attached to top, for holding two pairs of cases. See page 546 for prices of Double Case Brackets, Style A.

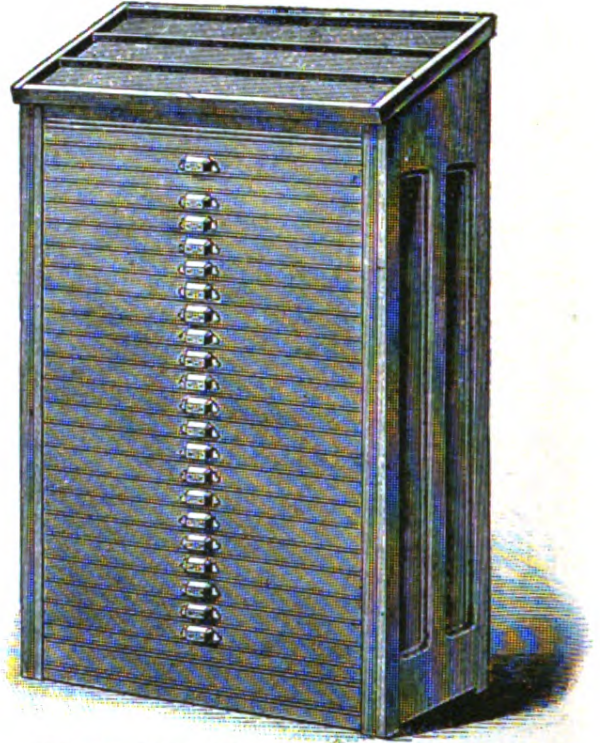

Twenty-Case Wisconsin Cabinet with Galley Top and Copy Drawer.

Although made of hard wood, these cabinets are sold at the same prices as ordinary cheap-looking stained cabinets. Three-quarter and full-size cabinets are furnished with California job cases, described on page 471, which are preferable to italic cases, as they afford more room for the caps. The bottoms are made flush with the floor, to prevent pi from getting underneath. The sides are double paneled and very tastefully moulded. Double case brackets may be put on top of the flat-top cabinets, making a very convenient stand, the regular height from the floor. *Galley-top cabinets are kept in stock with twenty cases only, but can be furnished for twelve and sixteen cases to order, though not recommended.*

LIST PRICES.

	Flat Top.	Galley Top.
No. 19. With 12 two-third job cases	\$15 00	. . .
No. 20. With 16 two-third job cases	18 00	. . .
No. 21. With 20 two-third job cases	21 00	\$24 00
No. 22. With 12 three-quarter California job cases	18 00	. . .
No. 23. With 16 three-quarter California job cases	22 00	. . .
No. 24. With 20 three-quarter California job cases	26 00	29 00
No. 25. With 12 full-size California job cases	22 00	. . .
No. 26. With 16 full-size California job cases	26 00	. . .
No. 27. With 20 full-size California job cases	30 00	33 00

See page 485 for Blank Case Cabinets.

OPTION :—Purchasers desiring special assortment of cases in lieu of the California job case, can make selection to suit their requirements. If higher-priced cases are selected, the difference in price is added to the list price of the cabinet.

EVERYTHING FOR THE PRINTER.

PORTER'S PATENT EXTENSION-FRONT STEEL-RUN CABINET.

The sides of these cabinets are extended four inches beyond the fronts of the cases. These extensions serve the printer in two ways: (1) A case near the top of a cabinet may be taken from its rack and placed in a more convenient position for setting from, and will be held by the extensions without withdrawing another case. This cannot be done on any other cabinet. (2) The extensions permit cases to be drawn out further from the racks than is possible in other cabinets, making it easier to set out of the rear boxes. In addition, these cabinets have all the best points of other cabinets, such as steel runs, "New-Departure" cases, hard wood throughout, and are stronger than any other cabinets. The extension sides make it practicable to use higher cabinets, containing more cases in a tier, than can be advised where ordinary cabinets are used.

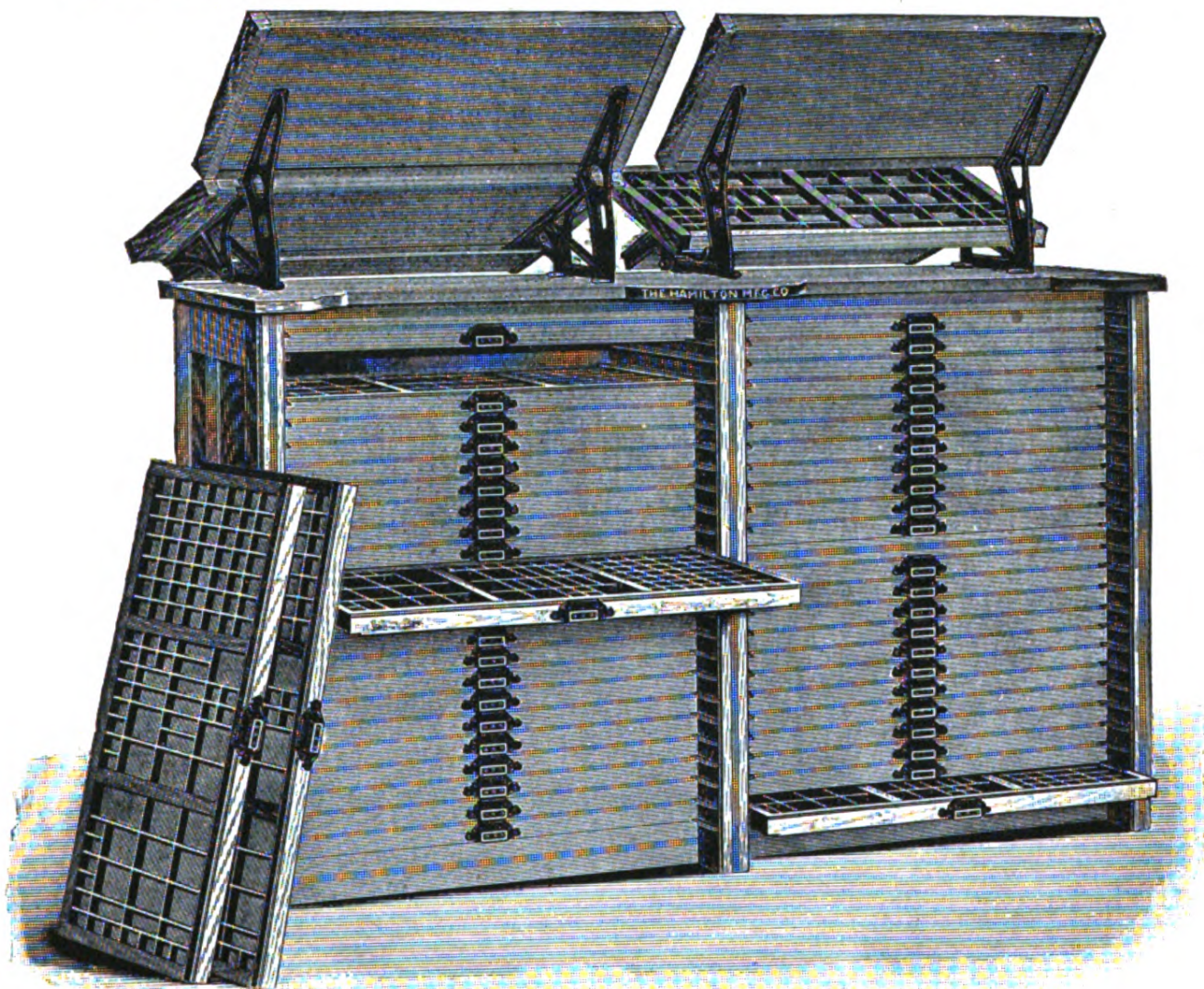

No. 7 Porter Steel-Run Cabinet.

LIST PRICES.

		Height Inches.	With Full-size California Job Cases—Flat Top.	With Full-size Blank Cases for Electrotypes.
No. 1.	25 cases, single tier	46	\$43 00	\$38 00
No. 2.	30 cases, single tier	53	51 00	45 00
No. 3.	40 cases, single tier	68	68 00	60 00
No. 4.	50 cases, single tier	84	85 00	75 00
No. 4.	50 cases, double tiers	46	85 00	75 00
No. 5.	60 cases, single tier	99	100 00	90 00
No. 5.	60 cases, double tiers	53	100 00	90 00
No. 6.	23 cases, single tier, with one pair tilting brackets and one pair news cases on top	43	45 00
No. 7.	46 cases, double tier, with two pair tilting brackets and two pairs news cases on top	43	90 00

These cabinets are 35½ inches wide and 22 inches deep. Depth of the extension front is 4 inches.
FOR OPTION ON CASES, see page 480.

BRUCE TYPE FOUNDRY, 13 CHAMBERS STREET, NEW YORK.

EVERYTHING FOR THE PRINTER.

AMERICAN STEEL-RUN CABINETS

Hold 50 per cent. more type in same floor space occupied by Regular 20-Case Cabinets.

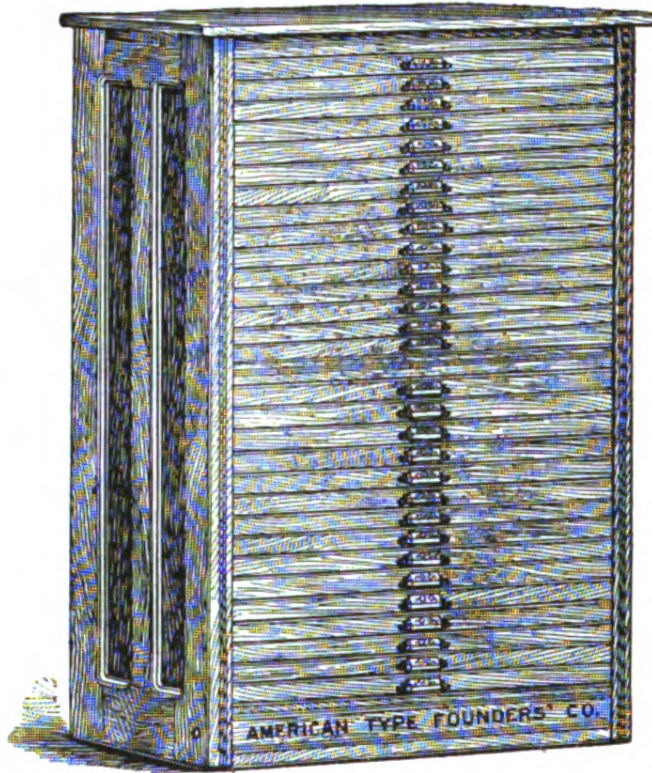

By substituting steel for wood in the runs, the awkward upper projections on the fronts of regular cabinet cases (which in the ordinary are put on to hide the wooden runs) are dispensed with, and ten more cases are got into the same space. Cases are easier to set out of, and *all cases are within easy reach of compositors of average height.*

The cabinets are made of hard wood, polished, braced in center to prevent spreading, and California job cases (giving one-third more room for caps by dispensing with two superfluous rows of boxes) are used instead of italic cases.

The height of the 30-case cabinets is 53 inches ; of the 40-case, 68 inches.

The illustration herewith shows the steel run used in American cabinets. Screws are countersunk.

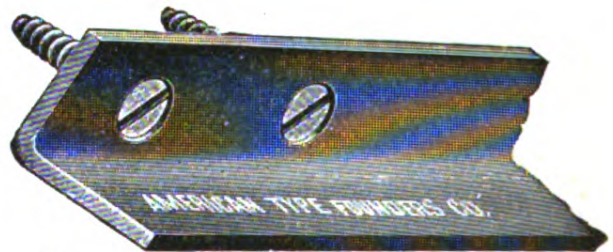

Shows Steel-Run with Countersunk Screws.

LIST PRICES.

	Flat Top.
30-case American Steel-Run Cabinet, with 30 two-third job cases	\$35 00
30-case American Steel-Run Cabinet, with 30 full-size California job cases	45 00
40-case American Steel-Run Cabinet, with 40 two-third job cases	48 00
40-case American Steel-Run Cabinet, with 40 full-size California job cases	60 00

OPTION.—Purchasers desiring special assortment of cases in lieu of the California job case, can make selection to suit their requirements. If higher-priced cases are selected, the difference in price is added to the list price of the cabinet.

BRUCE TYPE FOUNDRY, 13 CHAMBERS STREET, NEW YORK.

EVERYTHING FOR THE PRINTER.

**WISCONSIN CABINETS WITH STEEL RUNS.
FILLED WITH "NEW DEPARTURE" CASES.**

The merits of the modern Steel Run Cabinets have met with general recognition, and the best offices are now being equipped with these economical additions to the printing office. Where rents are high and space is limited these cabinets are especially recommended. They save twenty-five per cent. in space in the smaller sizes, and by using the high cabinets containing forty, fifty and sixty cases the saving is enormous. Space is utilized in the upper part of these high cabinets that was not occupied before. The same result is obtained by using high cabinets that is obtained in the eighteen-story office building.

The Capacity is Enormously Increased while the Ground Space Occupied Remains the Same.

Every case is easily accessible, because the ones at the top of the high cabinets can be taken out and brought down to the proper level.

See illustration of steel-run with countersunk screws on opposite page.

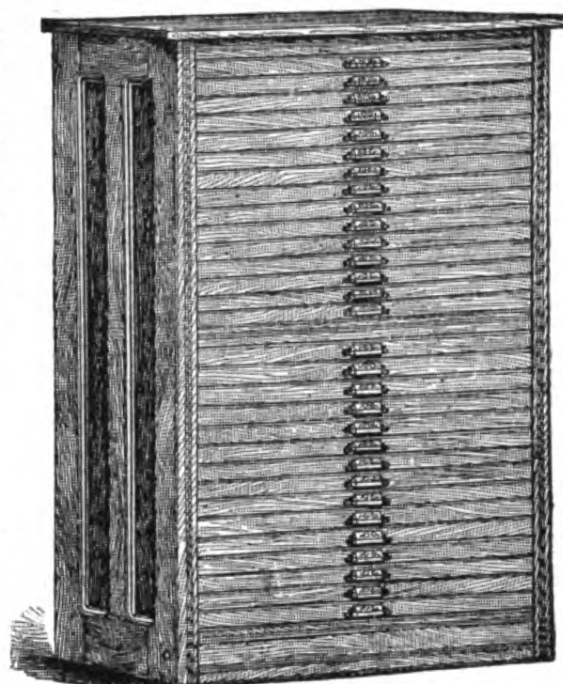

DIMENSIONS OF STEEL RUN CABINETS.

	Weight Full Size.	Height.		Weight Full Size.	Height.
20-case cabinets . . .	250 lbs.	37 3/8 inches	40-case cabinets . . .	475 lbs.	68 inches
25-case cabinets . . .	300 lbs.	44 1/4 inches	50-case cabinets . . .	575 lbs.	84 inches
30-case cabinets . . .	350 lbs.	53 inches	60-case cabinets . . .	650 lbs.	99 inches
		Full Size.		Three-quarter Size.	Two-third Size.
Depth		20 5/8 inches		19 5/8 inches	19 5/8 inches
Width		35 3/4 inches		29 3/4 inches	25 1/4 inches

PRICE LIST OF WISCONSIN STEEL RUN CABINETS.

	With Two-third Job Cases and Three-quarter and Full-size California Job Cases.		With Blank Cases for Electrotypes.	
	Flat Top.	Galley Top.	Flat Top.	Galley Top.
No. 1. With 20 two-third cases	\$25 00	\$28 00	\$21 00	\$24 00
No. 2. With 25 two-third cases	30 00	33 00	25 00	28 00
No. 3. With 30 two-third cases	35 00	. . .	29 00	. . .
No. 4. With 40 two-third cases	48 00	. . .	40 00	. . .
No. 5. With 50 two-third cases	60 00	. . .	50 00	. . .
No. 6. With 60 two-third cases	72 00	. . .	60 00	. . .
No. 7. With 20 three-quarter cases	30 00	33 00	26 00	29 00
No. 8. With 25 three-quarter cases	35 00	38 00	30 00	33 00
No. 9. With 30 three-quarter cases	40 00	. . .	34 00	. . .
No. 10. With 40 three-quarter cases	53 00	. . .	45 00	. . .
No. 11. With 50 three-quarter cases	65 00	. . .	55 00	. . .
No. 12. With 60 three-quarter cases	78 00	. . .	66 00	. . .
No. 13. With 20 full size cases	35 00	38 00	31 00	34 00
No. 14. With 25 full size cases	40 00	43 00	35 00	38 00
No. 15. With 30 full size cases	45 00	. . .	39 00	. . .
No. 16. With 40 full size cases	60 00	. . .	52 00	. . .
No. 17. With 50 full size cases	75 00	. . .	65 00	. . .
No. 18. With 60 full size cases	90 00	. . .	78 00	. . .
Double Case Brackets, per pair				1 25

Nos. 2, 8 and 14 are correct height to use with patent tilting brackets, in same manner as on Polhemus cabinets shown on page 475.

The Fifty-case and Sixty-case cabinets are furnished in one or two tiers, as desired. Brass label holders attached to any cabinet at an additional price of five cents per case list.

EVERYTHING FOR THE PRINTER.

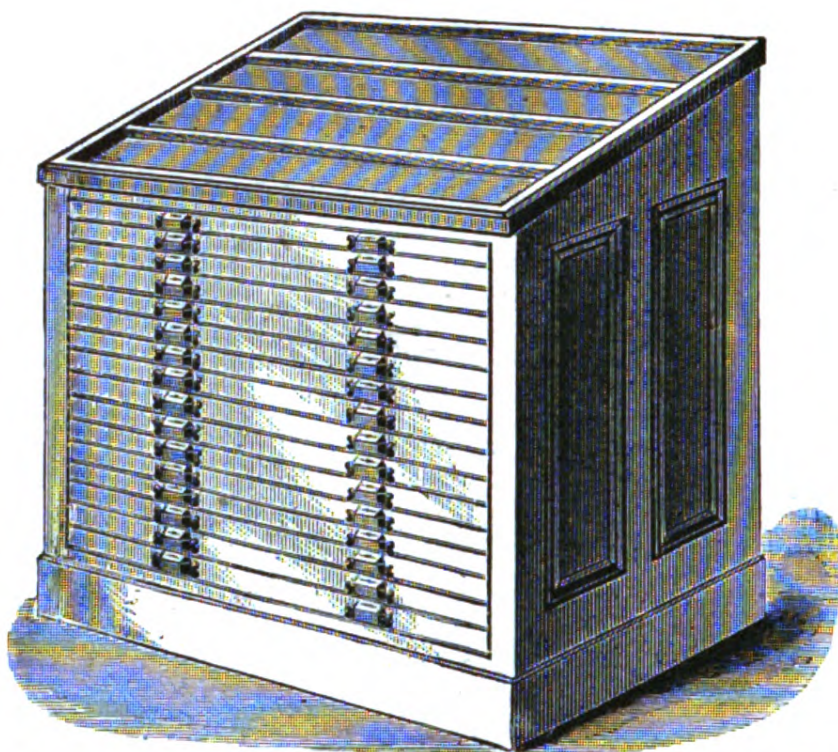

No. 5 Wood-Type Cabinet, with Galley Top. Occupies nine square feet floor space, and affords one hundred and twelve square feet for storage of type.

WOOD-TYPE CABINETS.

Very substantially constructed of hard wood. The cases are slotted on the sides, and have movable strips which may be adjusted to Picas. The cases in the Mammoth Cabinet (23 × 44 inches) have a center bar, and cases in the Regular Cabinet (23 × 32 inches) have no center bar.

These cabinets afford the most economical method of keeping wood type. The top of cabinet is available for use in laying out lines. They save the time lost in climbing to shelves, and the wood type is kept clean and is less liable to warp.

	Flat Top.	Galley Top.
No. 1. 12 cases, 23 × 32 inches	\$24 00	\$27 50
No. 2. 16 cases, 23 × 32 inches	30 00	33 50
No. 3. 20 cases, 23 × 32 inches	36 00	39 50
No. 4. 12 cases, 23 × 44 inches	30 00	34 00
No. 5. 16 cases, 23 × 44 inches	40 00	44 00
No. 6. 20 cases, 23 × 44 inches	48 00	52 00

WOOD-TYPE CASE RACK.

To hold twenty No. 3 wood-type cases (made to order) \$9 00

For prices of wood-type cases, see page 468. No. 3 Wood-type cases are 23 × 44 inches over all, and the price is \$1 30 each.

BOOKBINDERS' CABINETS.

Made of hard wood, with bronzed pulls on each case. The cases are made in exactly the same style as printers' cases. These cabinets occupy a space of 20 × 20 inches, and may be put on or under a bench. "A place for everything and everything in its place" is a rule bookbinders should live up to, and these cabinets enable them to do so.

- Cabinets with 6 cases . \$ 8 00
- Cabinets with 10 cases . 12 00
- Cabinets with 15 cases . 16 50

BOOKBINDERS' CASE.

Half cap case, 16 × 16 1/4 inches, without bronze pull, each \$0 60

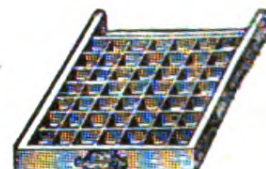

Case used in Bookbinders' Cabinet.

EVERYTHING FOR THE PRINTER.

HANDY LETTER BOARD CABINETS.

For the storage and safe keeping of job work these cabinets are unrivaled. Their cost will be saved in a few months by the prevention of pi. They occupy a floor space of 16×19 inches, with letter boards of 12×15 inches inside, and are made of hard wood throughout, in a solid and substantial manner. Boards are closed at sides and back, and are rabbeted in front to receive galleys. They are well-named "Handy." For job work within their size—and this the larger variety of such work—these small boards are much superior to the larger boards usually put under imposing tables, as it is a back-breaking job to get a form from these large boards when they are full of type.

It is distinctly an economy to place dead and live forms in such a receptacle as this, rather than to incumber useful space on an imposing stone, the type on which is always liable to damage. The protection they afford from dust is also worthy of consideration.

- With 10 boards \$10 50
- With 12 boards 12 00
- With 16 boards 15 00

Other sizes made to order at proportionate prices.

Handy Letter Board Cabinet with Sixteen Boards.

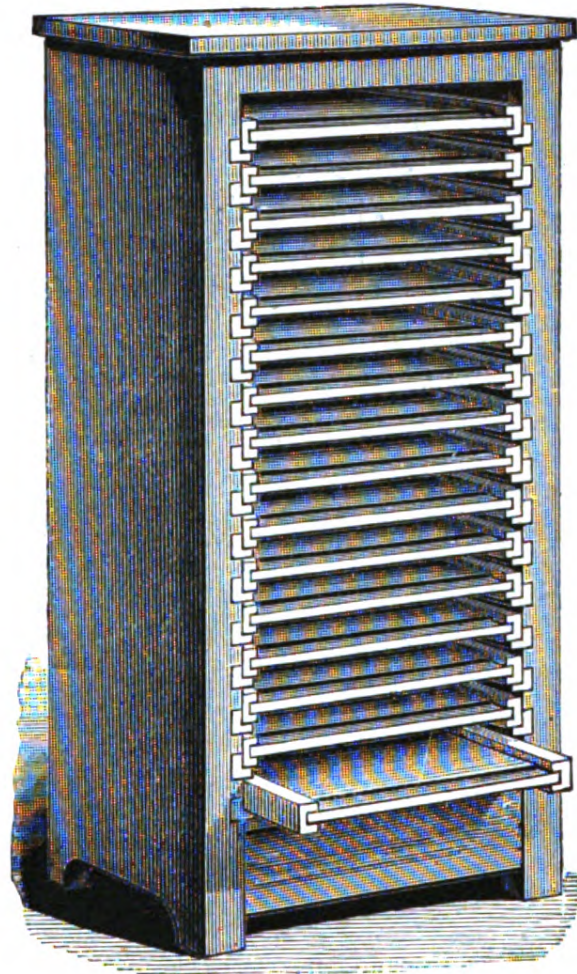

HARD-WOOD LETTER BOARDS.

Made of selected stock, smooth and true, with closed sides and backs, rabbeted in front to allow matter to slide on galleys easily. These boards have projecting backs so that they can be pulled out of the racks to the full extent of their inside measurements.

- No. 1, 21¼ × 20½ inches outside, fits two-third case stands \$1 20
- No. 2, 26¼ × 20½ inches outside, fits three-quarter stands 1 40
- No. 3, 32¼ × 20½ inches outside, fits full-size stands or racks 1 70

INK AND ROLLER CABINETS.

A very necessary article of printing-office furniture. The use of it will result in a saving of ink and rollers, which will speedily pay for the cost of cabinet.



- No. 1, with shelf for ink, shelf for brayer and ink slab, and brackets to hold 6 eighth and 6 quarto rollers \$6 50
- No. 2, with shelf for ink, shelf for brayers and ink slabs, and brackets for 6 each eighth, quarto and half-medium rollers 9 50
- No. 3, with shelf for ink, shelf for brayers and ink slabs, and brackets to hold 12 each eighth, quarto and half-medium rollers 13 00

BRUCE TYPE FOUNDRY, 13 CHAMBERS STREET, NEW YORK.

EVERYTHING FOR THE PRINTER.

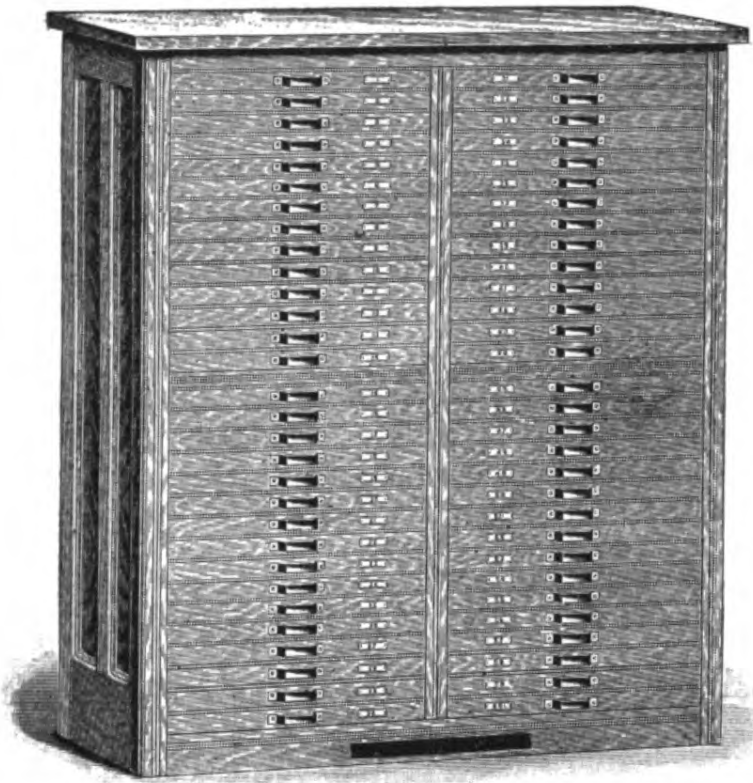

Nos. 6, 12, and 18 Cabinets, containing 60 Cases.

INDEXED ELECTRO-TYPE CABINET.

Fitted with the special cases illustrated below, each furnished with strong adjustable slotted partitions, each case numbered in front, and each section in the case designated by initial label, for which a secure holder is provided. The cuts in each lengthwise section are separated and held in place by shallow crosswise slats. An Index Book is furnished with each cabinet in which the cuts are indexed as follows:

ORIGINAL CUT			NAME OF CUT	ELECTROTYPES				
DRAWER	SECTION	DIVISION		DRAWER	SECTION	DIVISIONS		
12	D	3	Bicycle	31	E	1	2	3
12	A	2	Lawn Mower	33	A	4	5	6
12	E	3	Sewing Machine	35	B	1	2	3
12	D	4	Factory Plant	30	C	7	8	9

These cabinets meet in every respect the requirements of not only printers but of all manufacturing concerns that use cuts largely. Printers will do a favor to their customers of this class by calling their attention to these new cabinets. They are substantially and handsomely made of ash, finished in antique oak. The cases slide on steel runs, so that they take up the least possible space. The dimensions, weight and prices are given on next page.

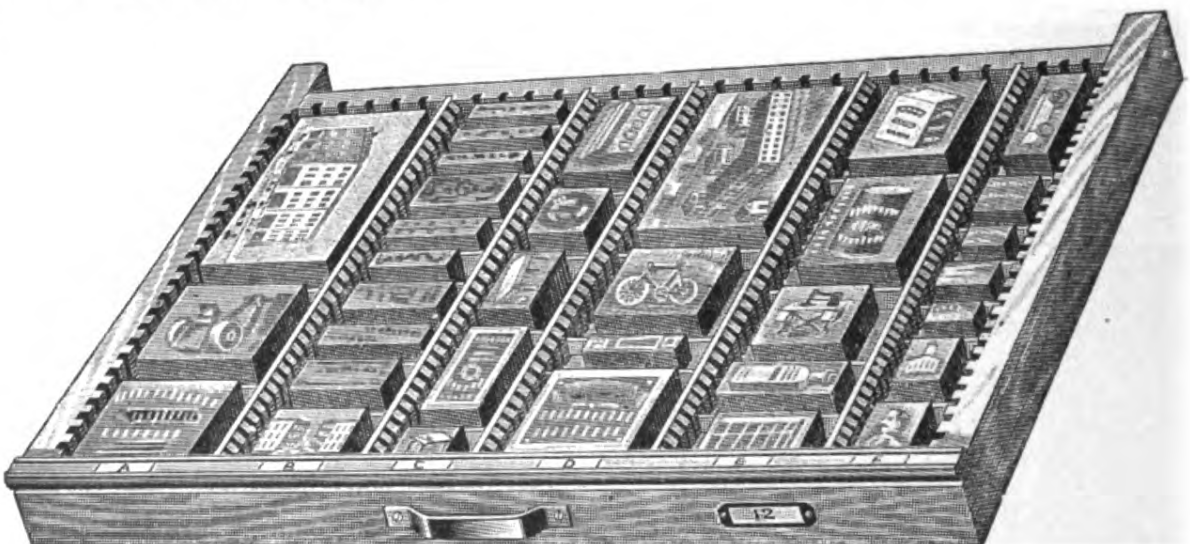

Case furnished in Indexed Electrotpe Cabinets.

Note that every cut is in a distinct compartment, and that as many sections and divisions of sections can be made as are desired. The plan of the index printed above refers to the case shown here.

BRUCE TYPE FOUNDRY, 13 CHAMBERS STREET, NEW YORK.

EVERYTHING FOR THE PRINTER.

PRICE LIST OF INDEXED ELECTROTYPE CABINETS.



The Division Slats, which are shallow, fit into these Section Slats as shown in cut on preceding page.

No.	Size of Cases Inches.	Height Inches.	Price.
1. With 20 two-third cases	16×21¾	38	\$25 00
2. With 25 two-third cases	16×21¾	45	30 00
3. With 30 two-third cases	16×21¾	53	35 00
4. With 40 two-third cases	16×21¾	68	48 00
5. With 50 two-third cases	16×21¾	84	60 00
6. With 60 two-third cases	16×21¾	99	72 00
7. With 20 three-quarter cases	16×26¼	38	30 00
8. With 25 three-quarter cases	16×26¼	45	35 00
9. With 30 three-quarter cases	16×26¼	53	40 00
10. With 40 three-quarter cases	16×26¼	68	53 00
11. With 50 three-quarter cases	16×26¼	84	65 00
12. With 60 three-quarter cases	16×26¼	99	78 00
13. With 20 full-size cases	16×32¼	38	35 00
14. With 25 full-size cases	16×32¼	45	40 00
15. With 30 full-size cases	16×32¼	53	45 00
16. With 40 full-size cases	16×32¼	68	60 00
17. With 50 full-size cases	16×32¼	84	75 00
18. With 60 full-size cases	16×32¼	99	90 00

The fifty-case and sixty-case cabinets are furnished in one or two tiers, as desired.

SPECIAL NOTICE.—The above prices include the cabinets fitted with a full equipment of division slats, including five of the slotted section divisions for each drawer in the two-third size cases, and six for each drawer in the three-quarter and full-size cases; also with a large assortment of cross divisions, in various lengths. Each drawer is fitted with a metal number plate, as shown in the illustrations on preceding page. One index book is furnished with each cabinet.



Flat-Top Sixteen-Case Electro Cabinet.

ELECTRO AND CUT CABINETS.

These cabinets are filled with blank cases, and are made of polished ash, with bronze case-pulls. The cases have extension backs. In addition to the ordinary use of the printer, these cabinets can be recommended to advertisers for keeping their wood cuts, etc., for keeping samples of hardware, confectionery, fancy stationery, for seeds, and for many other purposes.

All sizes can be supplied with galley tops at an advance of \$3.00 on flat-top prices, but galley tops are not recommended except on 20-case cabinets.

No.	Size of Cases Inches.	Height of Cabinet.	With Flat Top.	Galley Top.
No. 1.	12 two-third blank cases	34½ inches	\$12 00	. . .
No. 2.	16 two-third blank cases	43 inches	14 00	. . .
No. 3.	20 two-third blank cases	43 inches	16 00	\$19 00
No. 4.	12 three-quarter blank cases	34½ inches	15 00	. . .
No. 5.	16 three-quarter blank cases	43 inches	18 00	. . .
No. 6.	20 three-quarter blank cases	43 inches	21 00	24 00
No. 7.	12 full-size blank cases	34½ inches	19 00	. . .
No. 8.	16 full-size blank cases	43 inches	22 00	. . .
No. 9.	20 full-size blank cases	43 inches	25 00	28 00

BRUCE TYPE FOUNDRY, 13 CHAMBERS STREET, NEW YORK.

EVERYTHING FOR THE PRINTER.

LINOTYPE
MATRIX CABINET.

Has roll curtain front, with lock. Made of hard wood, beautifully finished, and very substantial. Each drawer is 14 1/4 x 15 inches inside, and holds 142 running inches of matrices set edgewise. A locked tool drawer, 4 1/2 inches deep, is placed at the bottom, which also holds the space bars on a brass rod.

- No. 1. 6 matrix and 1 tool drawers, height 29 1/2 ins. \$22 00
- No. 2. 8 matrix and 1 tool drawers, height 34 ins. 28 00
- No. 3. 10 matrix and 1 tool drawers, height 38 1/2 ins. 34 00
- No. 4. 12 matrix and 1 tool drawers, height 43 ins. 40 00

Six metal slugs, same shape and size as a matrix and 3/4-inch wide, furnished with each drawer. These hold up the matrices at ends of lines.

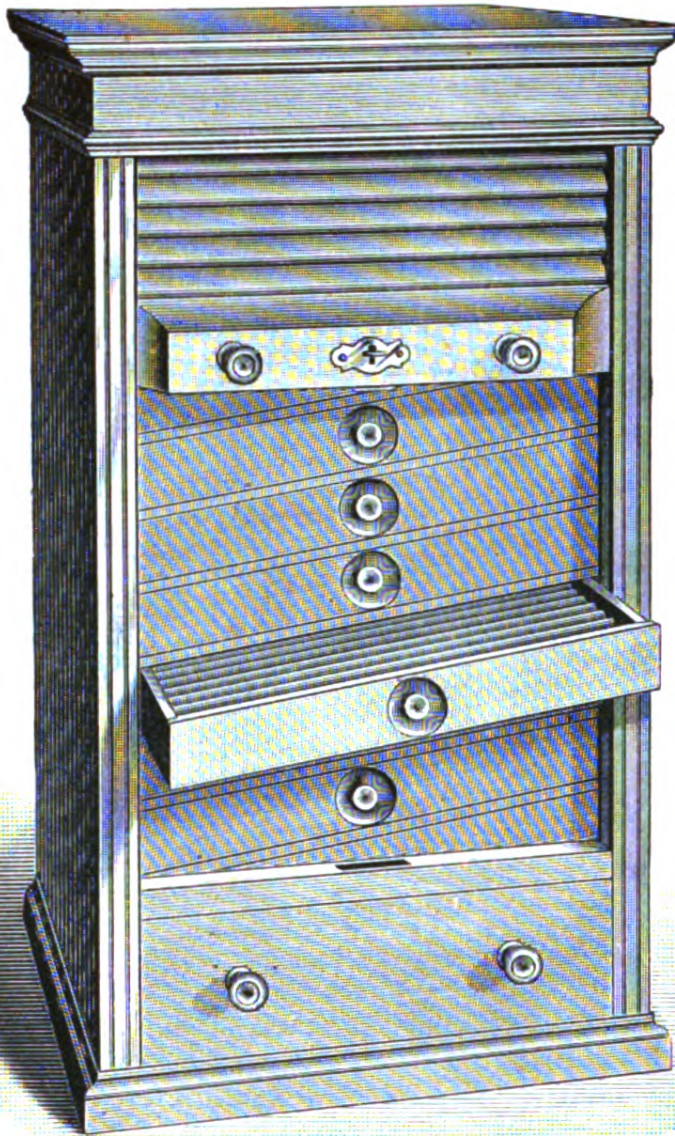

Eight-Drawer Linotype Matrix Cabinet.

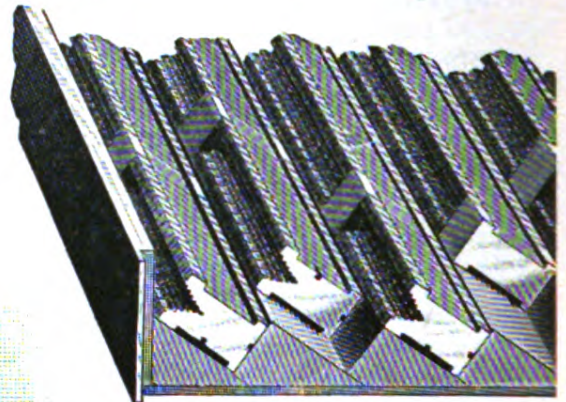

Detailed Section of Matrix Drawer, showing Matrices in place.

SPECIMEN CABINETS.

Made of ash. These cabinets are handsomely constructed, and will be an ornament to any office.

The drawers have movable partitions, and are made in two depths—2 1/2 inches and 5 inches. The No. 1 cabinet is the proper height for placing a letter-copying press on.

The methodical classification and preservation of specimens in a cabinet enables customers to decide on what they want quickly, and in many cases suggests other requirements. Let the public see what you have to sell, and they will become buyers.

- No. 1. 8 drawers, 26 inches wide by 19 inches deep by 37 inches high \$14 00
- No. 2. 12 drawers, 26 inches wide by 19 inches deep by 53 inches high 20 00

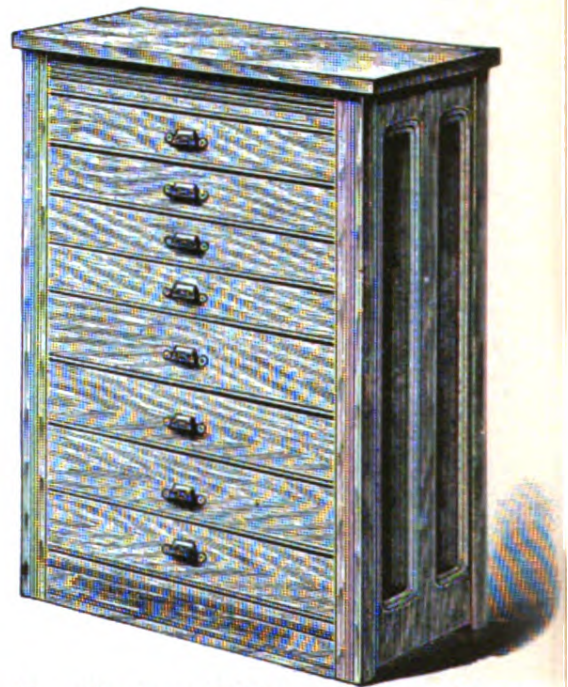

No. 1 Specimen Cabinet, 26 inches wide, 37 inches high, and 19 inches deep.

BRUCE TYPE FOUNDRY, 13 CHAMBERS STREET, NEW YORK.

EVERYTHING FOR THE PRINTER.

GALLEY CABINETS.

Made of thoroughly seasoned Hard Wood, in the most substantial manner.

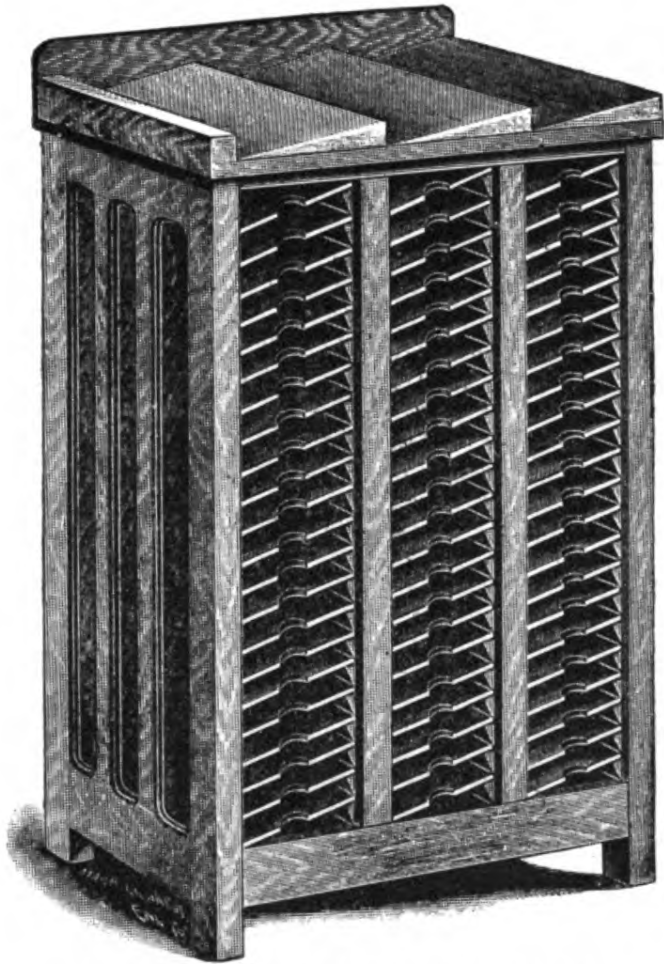

Three-tier Galley Cabinet with Galley Top, to hold Sixty-six Galleys.

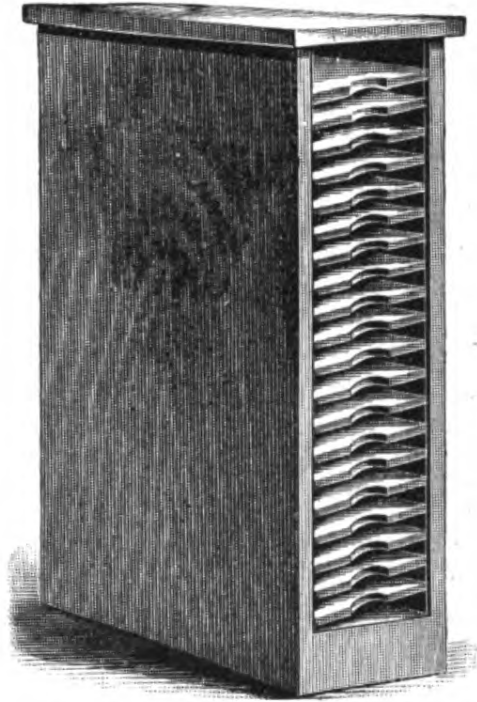

One-tier Flat-top Galley Cabinet, to hold Twenty Galleys.

Particular attention is directed to the galley cabinets of larger capacity. They are very desirable in the larger offices, and are designed to carry an immense weight of type safely. All these cabinets are made of hard wood. All flat-top cabinets are made same style as the one-tier cabinet illustrated above. All galley-top cabinets same as the three-tier cabinet shown on this page.

The "galley-top" cabinets are of much stronger construction than the "flat-top," and may be ordered with or without galley top, as desired, at the same prices.

	With Flat Top.	With Galley Top.	Boxing.
1 tier to hold 20 galleys	\$ 8 00	\$14 00	\$0 50
1 tier to hold 30 galleys	11 50	0 75
2 tiers to hold 40 galleys	15 00	25 00	1 00
2 tiers to hold 50 galleys	18 50	1 25
2 tiers to hold 60 galleys	22 00	1 50
3 tiers to hold 66 galleys	36 00	2 00
4 tiers to hold 88 galleys	47 50	2 50
6 tiers to hold 132 galleys	62 00	3 00
9 tiers to hold 198 galleys	85 00	4 00

NOTE.—The shelves in the larger cabinets should be numbered, and the proof of the galley should be numbered to correspond with the number on shelf, thus saving all the time required to locate galleys that are not so numbered. Iron number plates, made for numbering shelves, can be supplied at the following prices, net :

1 tier (20 galleys) . . \$1 00	2 tiers (50 galleys) . \$1 75	4 tiers (88 galleys) . \$3 00
1 tier (30 galleys) . . 1 25	2 tiers (60 galleys) . 2 00	6 tiers (132 galleys) . 4 00
2 tiers (40 galleys) . 1 50	3 tiers (66 galleys) . 2 25	9 tiers (198 galleys) . 5 00

BRUCE TYPE FOUNDRY, 13 CHAMBERS STREET, NEW YORK.

MOVABLE GALLEY RACKS.



Regular Galley Rack with Movable Galley Brackets.

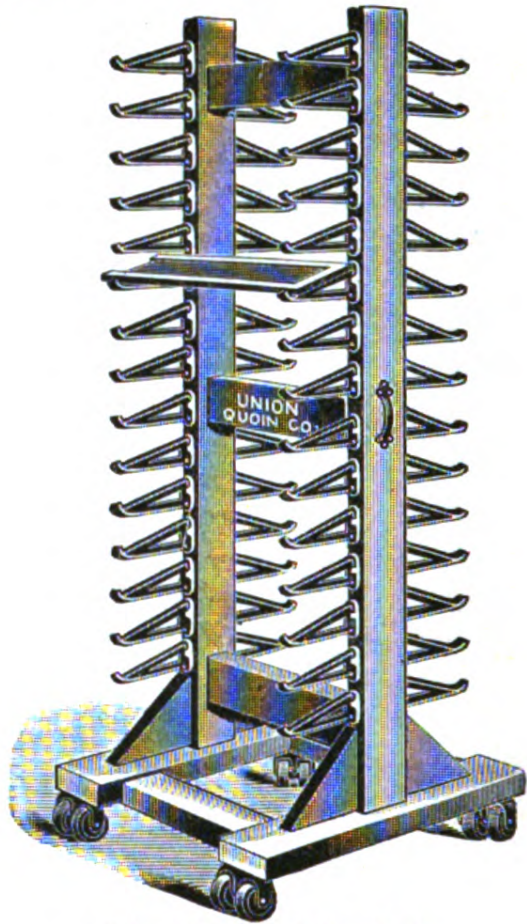

Union Movable Galley Rack.

UNION MOVABLE GALLEY RACK.

The Union Movable Galley Rack holds 30 galleys, and is mounted on strong casters so that it can be moved at will to the most convenient position for doing the work in hand.

Union Movable Galley Rack, holding 30 galleys \$21 00

REGULAR GALLEY RACK.

The Regular Galley Rack is intended for placing against the wall. The brackets are secured on a very strong hard-wood frame.

Regular Galley Rack, for 6 galleys	\$ 3 00
Regular Galley Rack, for 8 galleys	4 00
Regular Galley Rack, for 10 galleys	5 00
Regular Galley Rack, for 12 galleys	6 00
Regular Galley Rack, for 15 galleys	7 50
Regular Galley Rack, for 20 galleys	10 00

GALLEY BRACKETS.

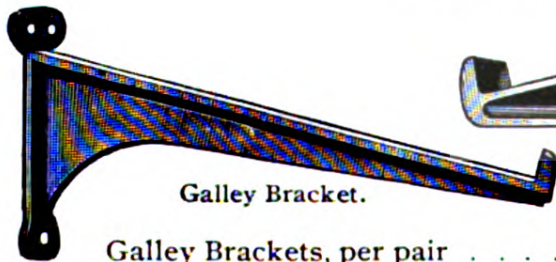

Galley Bracket.

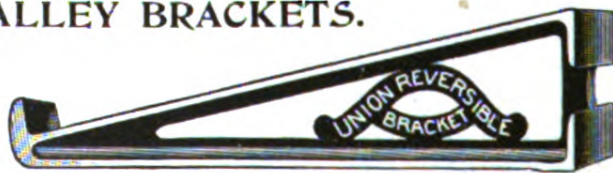

Union Reversible Galley Bracket and Socket.

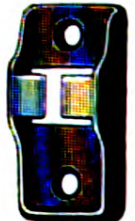

Galley Brackets, per pair	\$0 40
Union Reversible Galley Brackets, with sockets, per doz. pairs, \$6 00; per pair	0 60

EVERYTHING FOR THE PRINTER.

LABOR-SAVING LEAD RACKS.

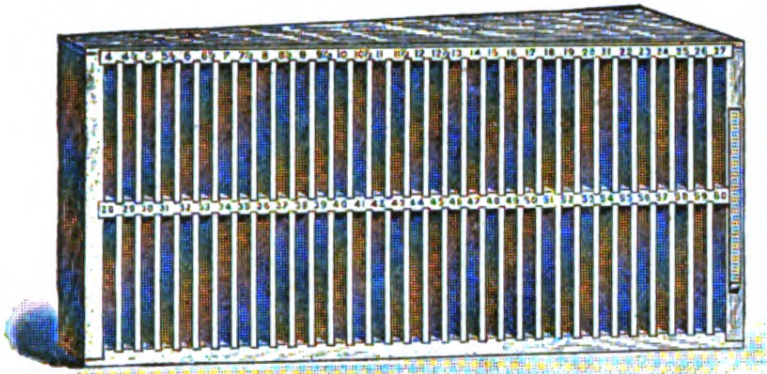

Two-tier Wisconsin Lead Rack ; 4 to 12½ by ens,
13 to 60 by ems.

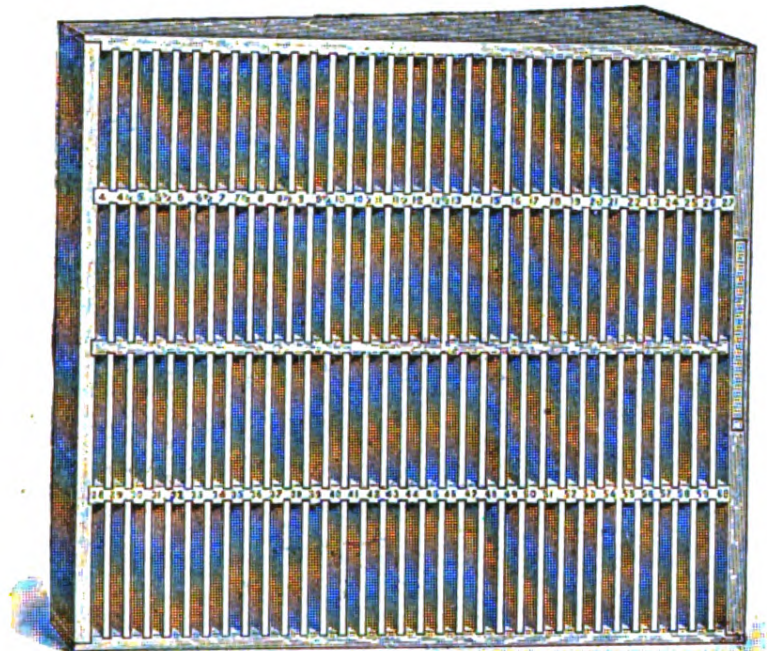

Four-tier Wisconsin Lead Rack ; 4 to 12½ by ens,
13 to 60 by ems twice.

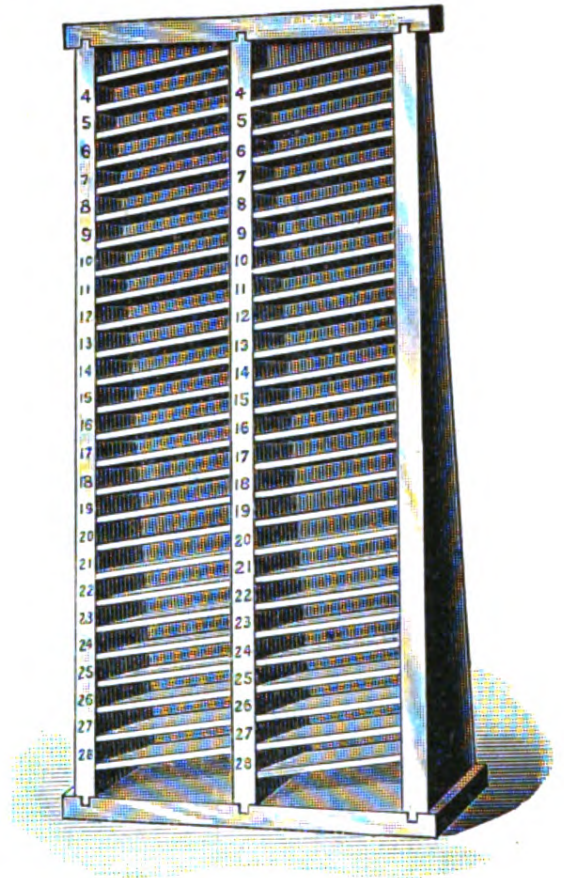

Eureka Lead Rack.

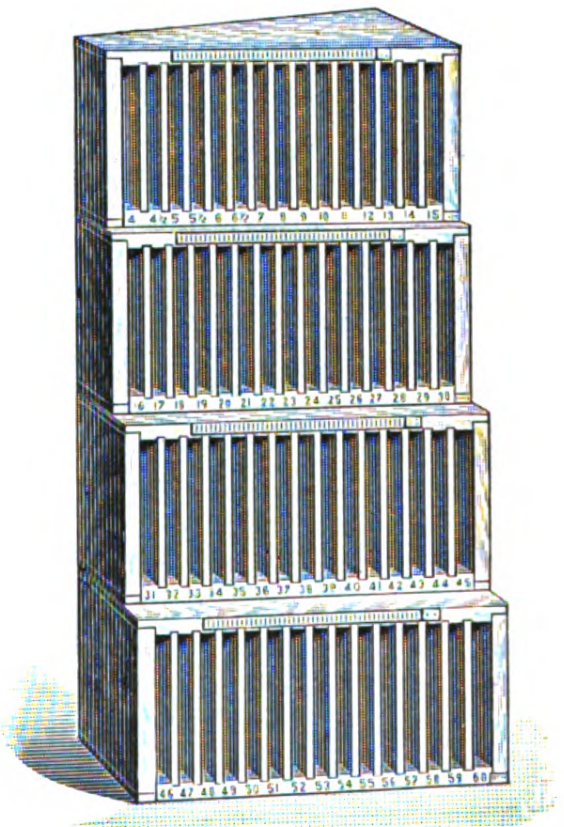

Boston Lead Racks.

PRICES.

- Two-tier Wisconsin Lead Rack \$6 00
Takes leads from 4 to 12½ ems (varying by ens), and from 13 to 60 ems (varying by ems), the length being stamped over each compartment. Compartments are eight inches high. Will hold 750 pounds of leads and slugs.
- Four-tier Wisconsin Lead Rack \$9 00
Has two compartments each for all sizes in the two-tier rack, and is similar in design and construction. Will hold 1500 pounds of leads and slugs.
- Eureka Lead Rack \$2 50
- Boston Lead Racks, set of four 5 40
 - No. 1 holds 4 to 15 ems lengths 0 90
 - No. 2 holds 16 to 30 ems lengths 1 20
 - No. 3 holds 31 to 45 ems lengths 1 50
 - No. 4 holds 46 to 60 ems lengths 1 80

BRUCE TYPE FOUNDRY, 13 CHAMBERS STREET, NEW YORK.

EVERYTHING FOR THE PRINTER.

WOOD FURNITURE, REGLET AND SIDE STICKS.

	Per yard.		Per yard.
Pearl to Pica Reglet	\$0 02	6- to 9-line Furniture	\$0 06
Gr. Primer Reglet to 2-line Furniture	0 03	10- to 12-line Furniture	0 08
3- to 5-line Furniture	0 04	13- to 16-line Furniture	0 10

SIDE STICKS, thin, medium or thick Per yard, \$0 06

**LABOR-SAVING
REGLET
CASES.**

Nos. 3, 4, 5, 6 are made same style as illustration.

The reglet lies flat, and varies by ems up to 51 ems, and by 5 ems in longer lengths. Nos. 1 and 2 are square boxes, in which reglet is put in on end, and varies by 10 ems up to 60 ems, with 72 and 120 ems added in the No. 2 case. One-half the pieces in each case are Pica body; the other half, Nonpareil body.

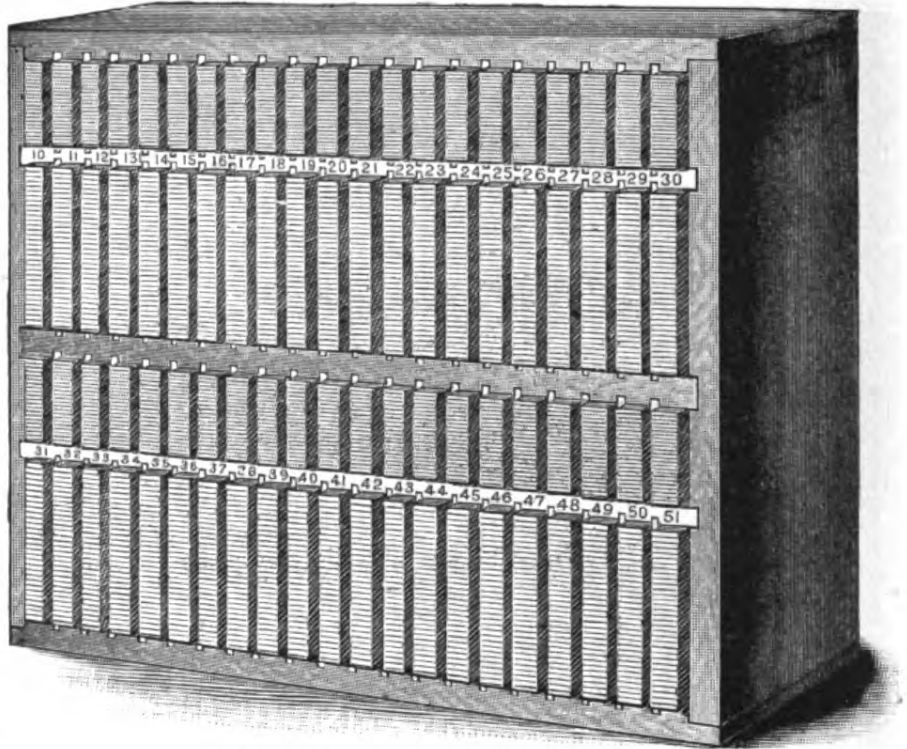

Reglet Case No. 4. 2100 pieces, \$8 00.

Case.	No. of Pieces.	No. of Yards.	Lengths in Case.	Price.
No. 1	1800	300	10 to 60 ems.	\$ 8 00
No. 2	2400	600	10 to 120 ems.	14 00
No. 3	4200	550	10 to 51 ems.	15 00
No. 4	2100	275	10 to 51 ems.	8 00
No. 5	6300	1500	10 to 150 ems.	38 00
No. 6	3150	750	10 to 150 ems.	20 00

REGLET CUT TO LENGTHS.

Nonpareil or Pica. Tied in Bundles.

100 pieces, 10 ems long	\$0 15	100 pieces, 45 ems long	\$0 50
100 pieces, 15 ems long	0 20	100 pieces, 50 ems long	0 55
100 pieces, 20 ems long	0 25	100 pieces, 55 ems long	0 60
100 pieces, 25 ems long	0 30	100 pieces, 60 ems long	0 65
100 pieces, 30 ems long	0 35	100 pieces, 65 ems long	0 70
100 pieces, 35 ems long	0 40	100 pieces, 70 ems long	0 75
100 pieces, 40 ems long	0 45		

Other lengths at proportionate prices.

LABOR-SAVING FURNITURE, WITHOUT CASES.

Half font of 280 pieces, in a box	\$2 75
Single font of 560 pieces, in a box	5 00
Double font of 1120 pieces, in a box	10 00
Mammoth font of 1530 pieces, in a box	25 00

BRUCE TYPE FOUNDRY, 13 CHAMBERS STREET, NEW YORK.

EVERYTHING FOR THE PRINTER.

LABOR-SAVING FURNITURE.

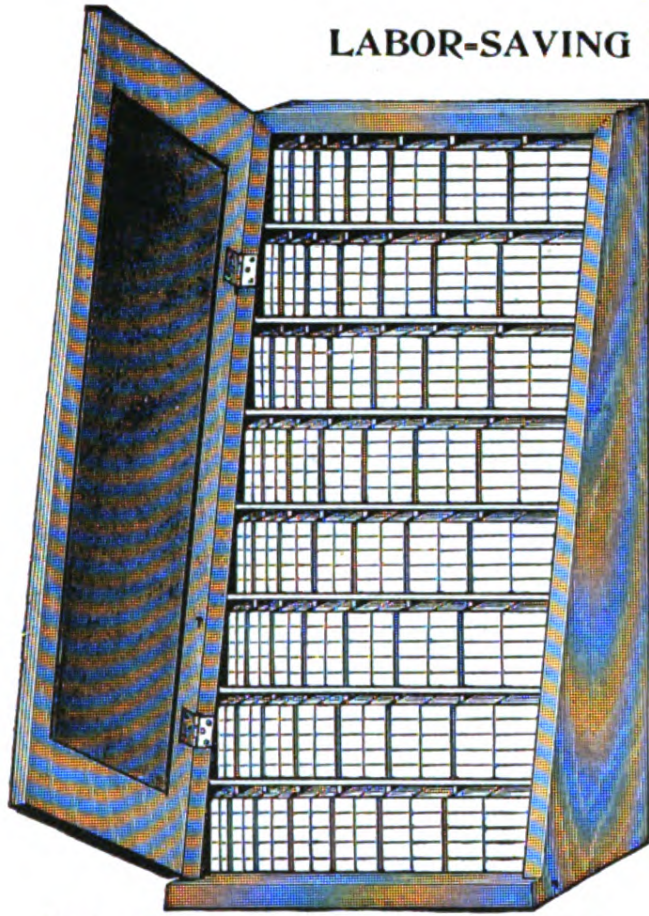

No. 3. Single Case, with Partitions and Door.

This Labor-Saving Furniture is thoroughly oiled, and cut to the point standard. Every piece has the size stamped on the end.

Cases are made *with* or *without* partitions. The usefulness of the font is doubled by having it in a case with partitions.

A single case contains 560 pieces, divided into 10 pieces, each 10, 15, 20, 25, 30, 40, 50 and 60 ems long by 2, 3, 4, 5, 6, 8 and 10 ems wide.

A half case contains half the number of pieces held in a single case.

THE No. 7 MAMMOTH CASE

is especially designed for large offices, and contains the following assortment of selected furniture, from 10 to 160 ems long : 270 pieces each 2-line, 3-line and 4-line furniture; 225 pieces each 5-line and 6-line furniture; 135 pieces each 8-line and 10-line furniture—assorted in 10, 15, 20, 25, 30, 40, 50, 60, 70, 80, 90, 100, 120, 140 and 160 ems lengths. There is a larger proportion of the narrower and most-used sizes than of the wide furniture.

- No. 1. Half case contains 280 pieces, with partitions . . . \$ 6 00
- No. 2. Half case contains 280 pieces, without partitions . . . 5 00
- No. 3. Single case contains 560 pieces, with partitions . . . 10 00
- No. 4. Single case contains 560 pieces, without partitions . . . 8 00
- No. 5. Double case contains 1120 pieces, with partitions . . . 18 00
- No. 6. Double case contains 1120 pieces, without partitions . . . 15 00

No. 7. Mammoth case, designed for large offices, with partitions, no door (see description above) 40 00

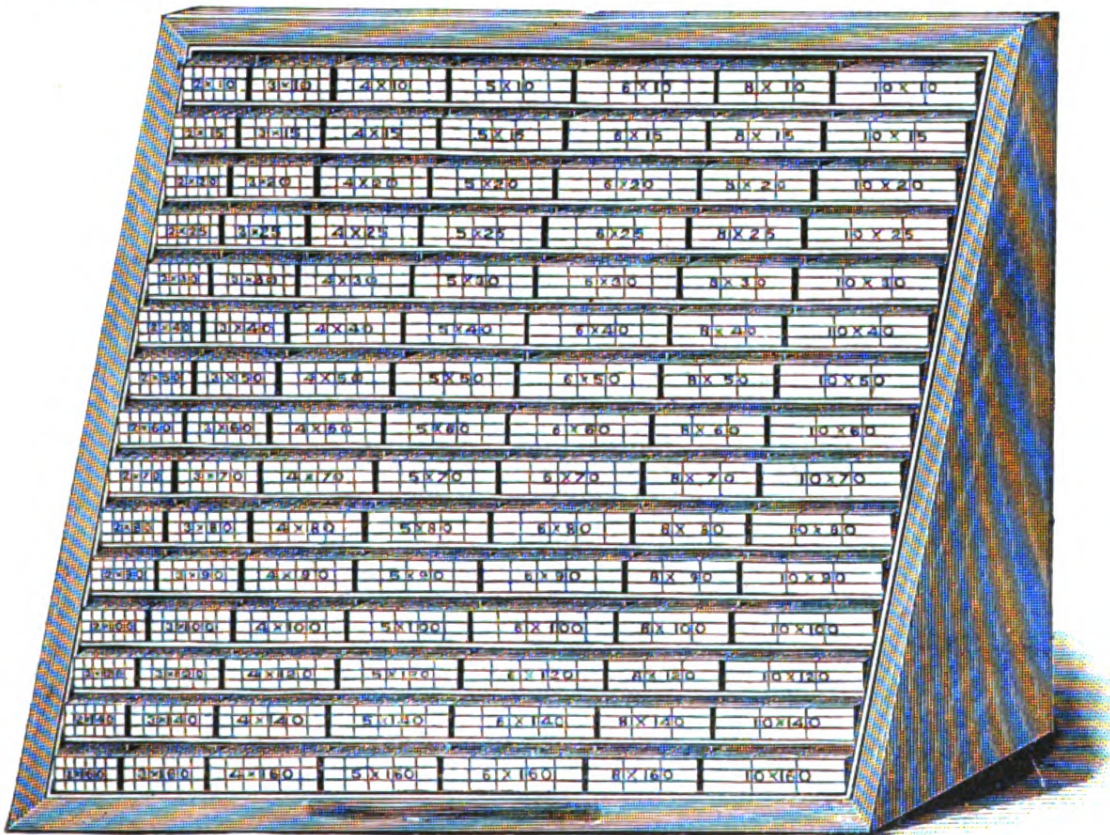

No. 7. Mammoth Labor-Saving Furniture Case.

BRUCE TYPE FOUNDRY, 13 CHAMBERS STREET, NEW YORK.

EVERYTHING FOR THE PRINTER.

IMPOSING TABLES AND MARBLE STONES.



Square-leg Imposing Table.

The imposing stone is an important piece of furniture in every printing office, and should be carefully selected with a view of getting the best the market affords. Our line is unsurpassed. The tables are made strong and serviceable, and fitted with the best hard marble tops and a strong coffin.

	Marble Stone.	Square-leg Table and Stone.	Round-leg Table and Stone.
For 6-column paper, 2 pages 24×36 inches	\$ 6 00	\$13 25	\$16 00
For 7-column paper, 2 pages 26×44 inches	8 00	16 00	20 00
For 8-column paper, 2 pages 28×50 inches	10 00	19 00	24 00
For 9-column paper, 2 pages 32×60 inches	13 50	23 50	28 50
For 7-column paper, 4 pages 26×76 inches	13 75	24 50	35 00
For 8-column paper, 4 pages 28×80 inches	15 50	28 00	38 00
For 9-column paper, 4 pages 30×90 inches	18 75	33 25	43 75
For 6-column quarto, 4 pages 36×60 inches	15 00	27 00	32 00
For 7-column quarto, 4 pages 48×60 inches	20 00	35 00	40 50

COFFINS.—When coffins only are desired, they can be had in any size, at 75 cents per running foot the long way.

A "coffin" is a hard wood frame which serves as a bed for the stone, protects its edges, and affords a rest for galleys when used for sliding off matter.

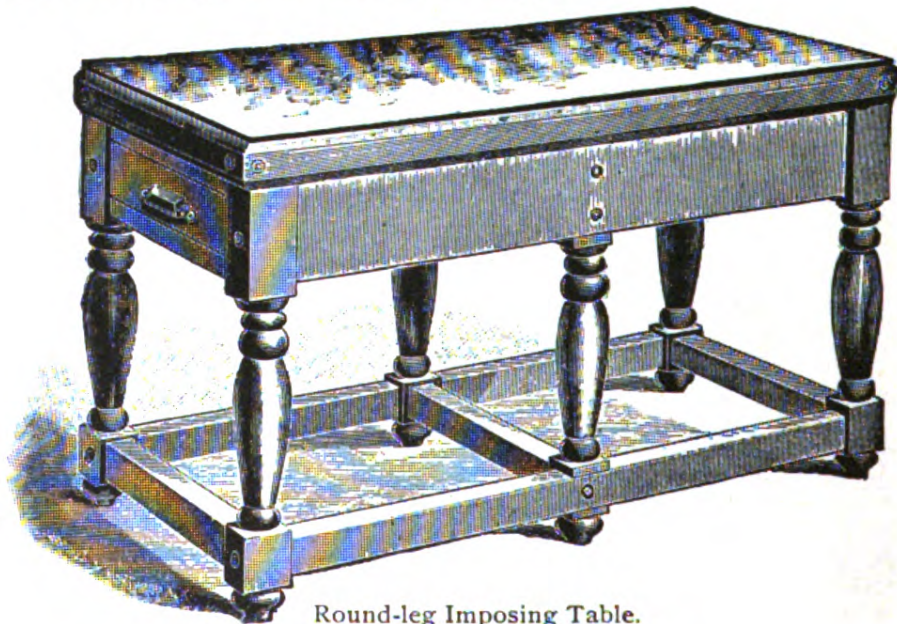

Round-leg Imposing Table.

BRUCE TYPE FOUNDRY, 13 CHAMBERS STREET, NEW YORK.

EVERYTHING FOR THE PRINTER.

IMPOSING TABLES WITH LETTER BOARDS.

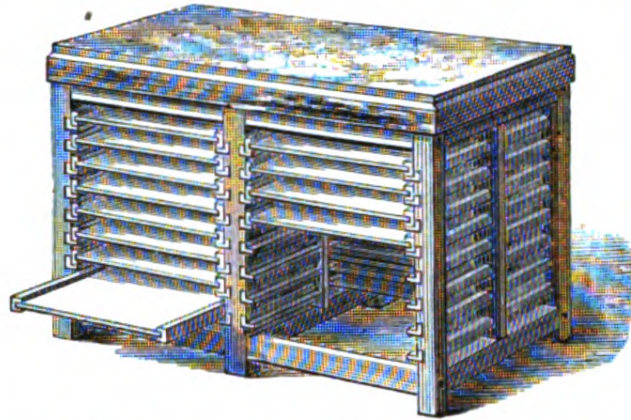

No. 9. With 36×60-inch Marble Top; has 32 Letter Boards, each 17½×26 inches inside.

No better disposition of the space underneath an imposing table can be made than to use it for letter boards. If the type is dead, it is shifted from the stone to the board without loss of time; if the matter is alive, it is handy for imposition.

These tables are made in the most substantial manner, of hard wood, and are strongly and firmly bolted together. The boards are made of hard wood, closed at sides and back, and are rabbeted in front to receive galley when sliding off type.

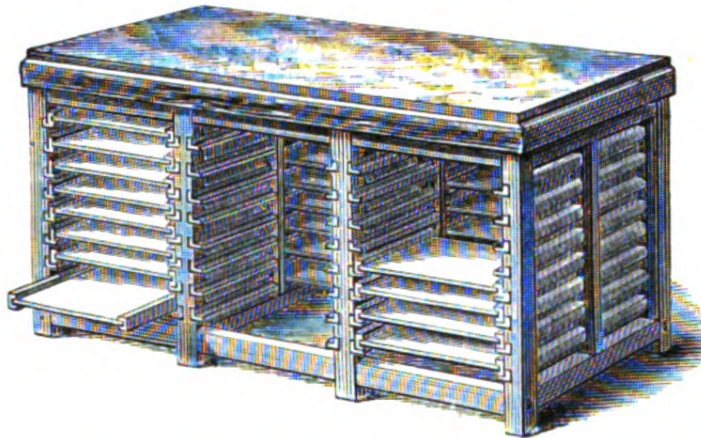

No. 10. With 40×80-inch Marble Top; has 48 Letter Boards, each 19½×22½ inches inside.

Prices with Hard Marble Stones.

	Number of Boards.	Size of Stone.	Size of Boards.	Without Boards.	Boards each.	Complete with Boards.
No. 2	10	24×36	22 ×32	\$40 00
No. 3	10	32×48	30 ×44	60 00
No. 9	32	36×60	17½×26	\$42 50	\$1 00	72 50
No. 10	48	40×80	19½×22½	55 00	0 90	95 50

IRON IMPOSING SURFACES

Supplied any size to order 2½ cents per square inch, net.

MARBLE INK SLABS.

8×12 inches	\$1 25
12×18 inches	3 00
18×24 inches	3 75

BRUCE TYPE FOUNDRY, 13 CHAMBERS STREET, NEW YORK.

EVERYTHING FOR THE PRINTER.

MOVABLE DRYING RACKS.

The frames of both these racks are of hard wood, bolted together, and mounted on strong casters, so that they can be easily moved when loaded. The shelves of the Chicago Rack are framed all around with hard wood, while those of the New York Rack are framed on ends only.



No. 1 New York Drying Rack.

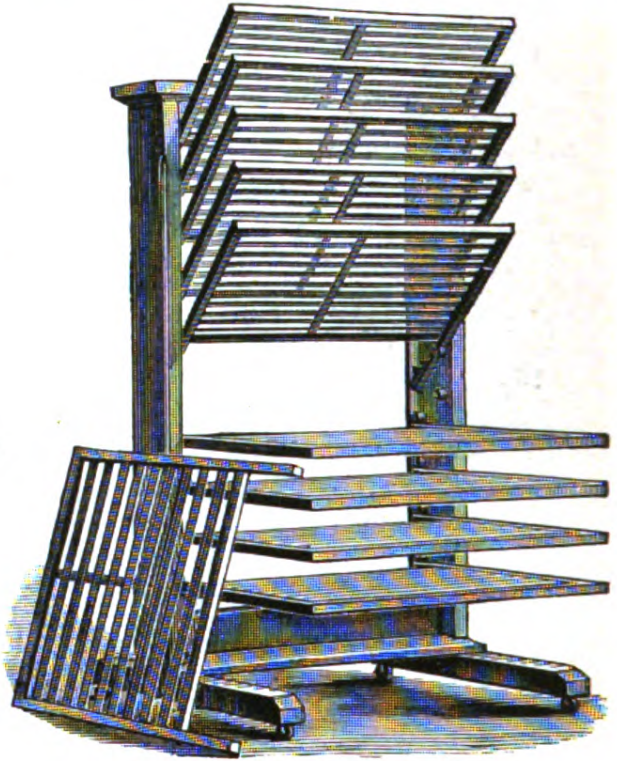

No. 6 Chicago Drying Rack.

NEW YORK DRYING RACKS.

- | | |
|---|---|
| No. 1. 20 shelves, each 24×36 in. . \$19 00 | No. 3. 20 shelves, each 28×42 in. . \$23 00 |
| No. 2. 30 shelves, each 24×36 in. . 23 00 | No. 4. 30 shelves, each 28×42 in. . 32 00 |

The No. 1 rack (the cheapest) gives a drying area of one hundred and twenty square feet, while actually using only six square feet of your costly floor space.

CHICAGO DRYING RACKS.

- | | |
|---|--|
| No. 5. 12 shelves, each 2×2 feet . . \$19 00 | No. 6. 10 shelves, each 2×3 feet . . \$22 00 |
| No. 7. 10 shelves, each 2½×4 feet . . \$26 00 | |

This rack is the most substantial movable drying rack made. Although it has fewer shelves than a New York, the extra space between the shelves is a distinct advantage, as on small jobs the sheets can be handled without moving the shelf on which they are placed. When not in use the shelves may be put out of the way, as illustrated in cut.

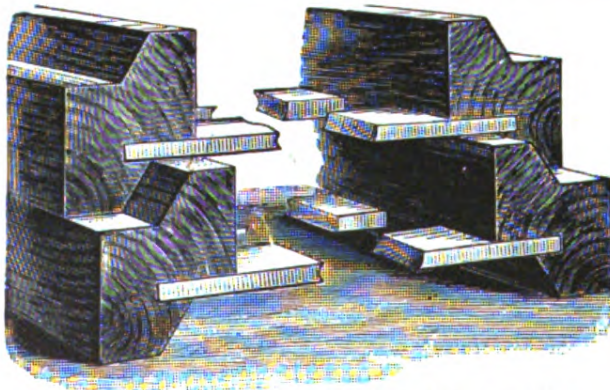

Figure 2. End View of Interlocking Device.

BEST RACKS FOR LARGE EDITIONS.

The Kærner Drying Racks, described on opposite page, have saved large firms thousands of dollars per year by enabling them to utilize their floor space to the utmost extent, making slip-sheeting unnecessary on very many jobs and preventing wastage by handling sheets. The interlocking device and method of inserting the slats into the sides is very plainly illustrated in Figure 2. No large establishment can afford to use wall-racks now that these effective racks, used in connection with trucks, will save their cost every month in the year.

KÖERNER'S PATENT INTERLOCKING DRYING RACKS.

(United States Patent, No. 392,735; Canadian Patent, No. 28,739.)

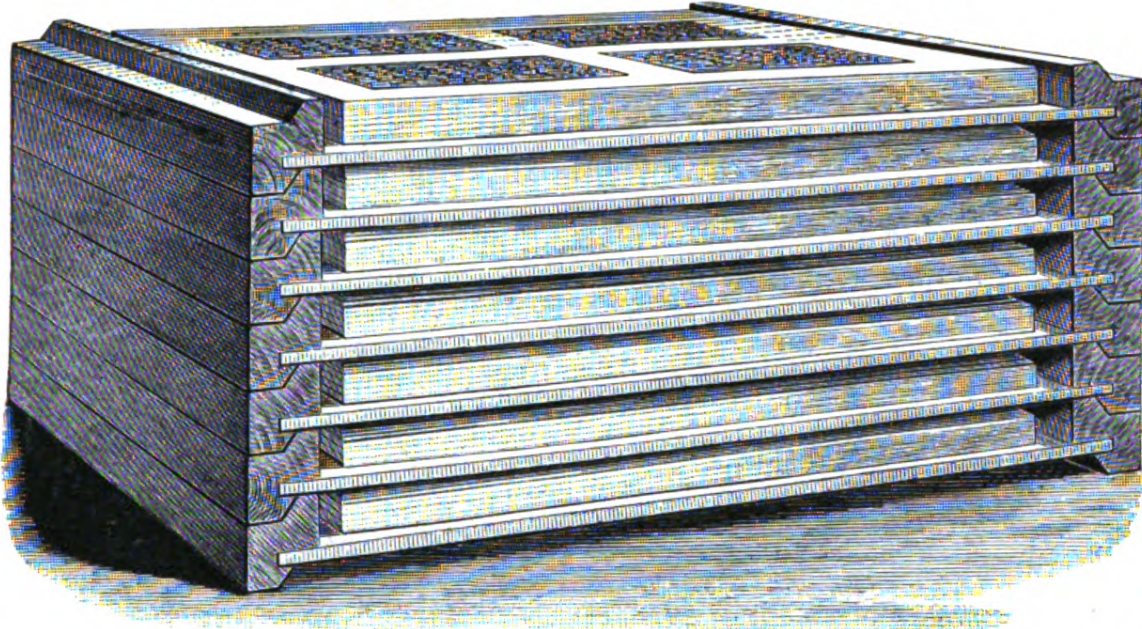

Fig. 2. Interlocking Racks Stacked with Paper, straight and rigid.
(See illustration of Interlocking Device on preceding page.)

These racks are for establishments which work on long runs, for color work, and for lithographers. They are used on *Puck* and *Truth*, and the American Lithographing Company has over 25,000 of them in its various establishments in New York City alone.

With these racks sheets are taken direct from the fly of the press, and may be stacked ceiling-high in a perfectly straight and rigid pile, which cannot be knocked over by accident, and with no more weight on the bottom than on the top sheets. This pile is a most effective drying room, occupying only the floor space of one rack, and from the time the sheets are fed into the machine until ready for shipment they need not be handled.

The interlocking device, which makes the pile straight and rigid, is shown in Figure 2. Each rack is firmly locked on its neighbor, but each slides with ease on the rack immediately below it. They save handling, all the time of that operation, and the consequent waste of paper through offset, smearing, finger-marks and tearing. In many cases these racks save expensive slip-sheeting. They circumvent electricity by receiving the sheet direct from the fly. They insure evenness of temperature, and thereby assist in getting a perfect register on lithographic work. They save seventy-five per cent. of floor space over any other method of drying sheets, and from one to two per cent. of paper, and a vast amount of time. A further saving of time may be effected by placing the racks as they come from the fly-board on a printer's truck, made to take these racks (see "Printers Truck"). A pile of racks can be moved quicker, safer and easier on the truck than a single armful can be moved by hand. The racks have hard-wood sides with wide soft-wood slats, and are very strongly put together.

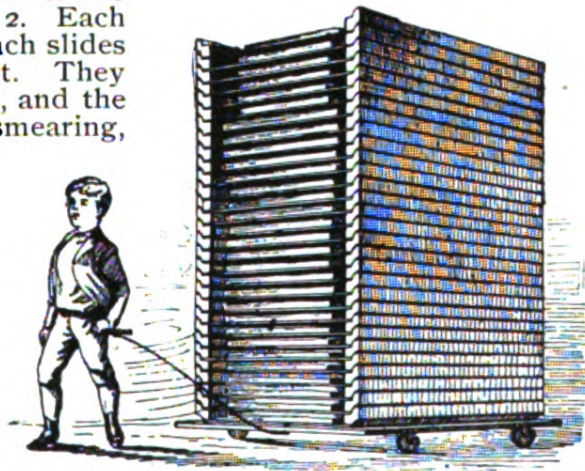

Fig. 1. Köerner's Racks on Printer's Truck.

NET PRICES.—Special Quotations Made on Car-load Lots.

These racks are made to order, and sizes will be varied to suit purchasers, at prices approximate to those quoted here:

38×52 in. inside and under \$0 65	15 ×21 in. inside and under . . . \$0 35
32×48 in. inside and under 0 60	13 ×19 in. inside and under . . . 0 30
24×36 in. inside and under 0 50	11 ×17 in. inside and under . . . 0 25
18×25 in. inside and under 0 40	8¾×13 in. inside and under . . . 0 20

BRUCE TYPE FOUNDRY, 13 CHAMBERS STREET, NEW YORK.

EVERYTHING FOR THE PRINTER.

PRINTERS' MACHINERY.

CHANDLER & PRICE GORDON PRESS.

A most popular press, and over 10,000 are in use. They are built to withstand both use and abuse. Side arms and shaft are made of forged steel, without seam or weld. Cam rollers are made of hardened tool steel. Impression throw-off is positive and easy to operate. The grippers are depressible, and cannot get under the rollers. Chase clamp is safe and instantaneous.

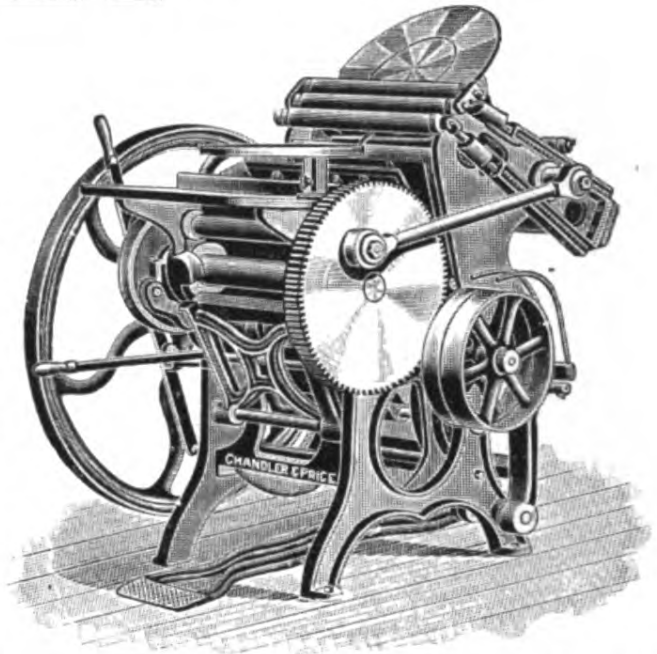

Eighth Medium,	7. × 11 inches inside chase	\$150 00
Eighth Medium,	8 × 12 inches inside chase	165 00
Quarto Medium,	10 × 15 inches inside chase	250 00
Half Medium,	12 × 18 inches inside chase	300 00
Large Half Medium,	14 × 20 inches inside chase	400 00
Half Super-Royal,	14½ × 22 inches inside chase	450 00
Steam Fixtures, all sizes		15 00
Buckeye Fountain		10 00
Chandler & Price Fountain		20 00
American Counter (see page 519), with attachments for any size press		12 00

WRITE FOR NET PRICES.

With each press there are three chases, one brayer, two wrenches, one set of cast rollers and one extra set of stocks. If desired, will send two extra chases or roller mould instead of covering one set of stocks with composition. No charge for boxing and shipping.

Shipping weights: 7 × 11, 1000 lbs.; 8 × 12, 1200 lbs.; 10 × 15, 1800 lbs.; 12 × 18, 2500 lbs.; 14 × 20, 3000 lbs.; 14½ × 22, 3100 lbs.

For prices of extra chases, see "Chases."

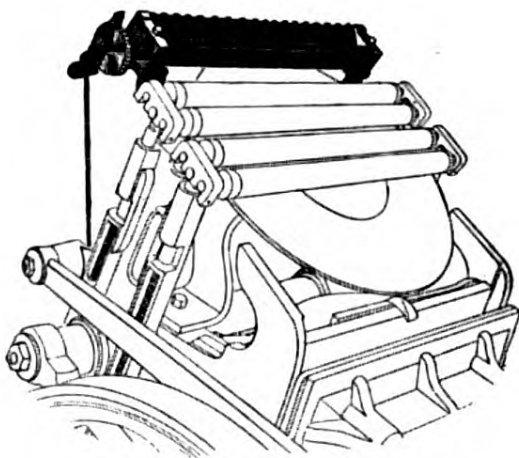

Chandler & Price Fountain.

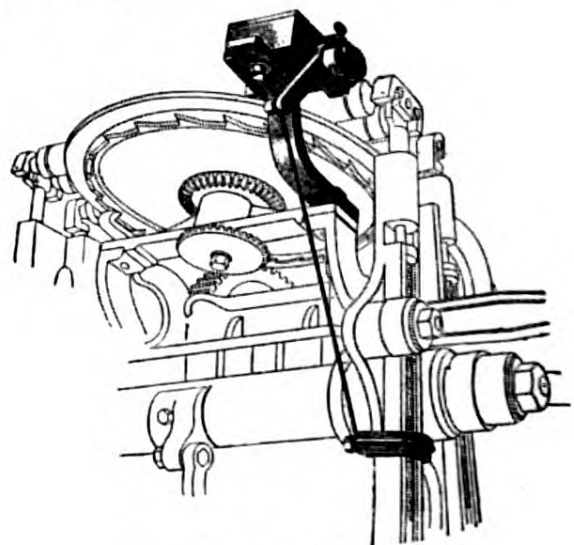

The Buckeye Fountain.

BRUCE TYPE FOUNDRY, 13 CHAMBERS STREET, NEW YORK.

EVERYTHING FOR THE PRINTER.

GALLY UNIVERSAL PRESS.

The Gally Universal Press is made in three styles, which are described on the following pages.

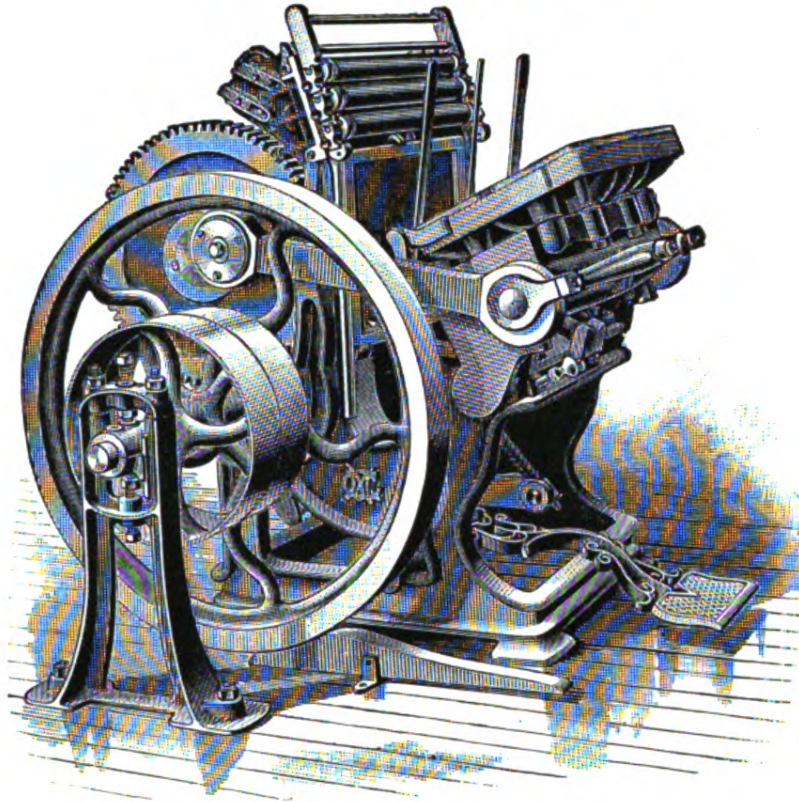

Excels all other types of platen presses because: (1) The bed and frame are cast in one piece, securing rigidity and keeping all shafts in line in spite of irregularities in floor or foundation. (2) The platen moves up squarely against the type form, giving a perfectly square impression. (3) The platen has nine supports, and is extra heavy, and is the only platen capable of sustaining the powerful impression necessary to secure the best results on large forms of cuts. (4) The impression can be thrown off instantly, the throw-off being controlled by a bar directly behind the platen. (5) The impression can be changed instantly all over the platen, varying from the imperceptible to an eighth of an inch. (6) The platen opens out widely, making it easy to feed paper into it. (7) The ink fountain is as efficient as the fountains on the highest grade cylinder presses. It is the most perfect fountain for a platen press ever made. (8) The operations of ink distribution and "inking" the form are distinct, and each performed by a separate set of rollers. In addition to the fountain ductor roller, there are four ink distributors (two of composition, two of iron) which supply two inking cylinders, from which the three form rollers receive a fresh, distributed supply of ink at each impression. On all other types of presses the form rollers have to distribute the crude ink as it leaves the fountain. (9) The form rollers can be held against the inking cylinders for distribution, while getting up color, and need not touch the type form. (10) The ink fountain can be divided by partitions for printing two or more colors at one time. (11) The weight and strength are greater than in any other platen press, as it is designed to do work that cannot be safely attempted on any other type of press.

The Gally Universal is designed for use by the best class of printers. In the hands of competent pressmen the press is the most durable, and will do first-class work in perfect register longer than any other press. We can refer purchasers to presses which have been in constant use for twenty years, doing perfect work to-day, and bidding fair to give the best results for years to come.

BRUCE TYPE FOUNDRY, 13 CHAMBERS STREET, NEW YORK.

EVERYTHING FOR THE PRINTER.

PRICES OF GALLY UNIVERSAL PRESSES.

F. O. B. FACTORY.

The following parts are included with each press: Ink fountain, power fixtures,* combination belt shifter and brake, three chases, one roller mould (for which two chases will be substituted, if preferred), six form roller stocks, four distributor roller stocks, two ductor roller stocks, twelve roller wheels (six large and six small), two iron lateral distributors, two feed tables, one small and one large wrench, one socket wrench, one chase latch wrench, and treadle fixtures. If treadle fixtures are not wanted, two chases will be sent instead.

If desired, we will cover one set of roller stocks with composition in lieu of roller mould.

* Power fixtures include fixtures on the press only.

BOXING FOR EXPORT: Quarto Medium, \$7 00; Half Medium, \$10 00; Half Super-Royal, \$15 00, net.

DESCRIPTION OF THE THREE STYLES.

STYLE No. 1.

This is the regular press, adapted for general commercial letterpress work.

Quarto Medium,	10×15 inches inside chase	\$350 00
Half Medium,	13×19 inches inside chase	450 00
Half Super-Royal,	14×22 inches inside chase	515 00

STYLE No. 2.

This style differs from Style No. 1 in that it is more heavily built and has a steel section in large gear wheel, and is specially adapted to the finest of work.

Half Medium,	13×19 inches inside chase	\$500 00
Half Super-Royal,	14×22 inches inside chase	575 00

STYLE No. 3.

This style differs from Style No. 2 in that it is more powerful and more heavily built, and is adapted by different combinations of special devices to different kinds of special work. It has heavier fly-wheel with outside floor support and extra wide driving pulleys for wide driving-belt. This press will do successfully all kinds of regular printing-office embossing, and in its different combinations is adapted to hot or cold work.

STYLE No. 3, COMBINATION A.

For letterpress printing of the highest grade, cold embossing, stamping, and all work that can be executed on a platen set to print at the height of type.

Quarto Medium,	10×15 inches inside chase	\$450 00
Half Medium,	13×19 inches inside chase	600 00
Half Super-Royal,	14×22 inches inside chase	650 00

STYLE No. 3, COMBINATION B.

For letterpress printing and (in addition to all work that can be done on Combination A) book-cover inlaying, and cutting and creasing. This combination is fitted with a movable ¼-inch steel platen plate and a movable ¼-inch brass platen plate, the latter for use in cutting and creasing.

Quarto Medium,	10×15 inches inside chase	\$470 00
Half Medium,	13×19 inches inside chase	626 00
Half Super-Royal,	14×22 inches inside chase	676 00

STYLE No. 3, COMBINATION C.

For letterpress printing and hot embossing (in addition to all work that can be done on Combinations A and B). This combination is fitted with a steam blank and pipe connections ¼ inch thick, movable ¼-inch steel plate on steam blank, a movable ¼-inch steel platen plate, a movable ¼-inch brass platen plate, one cast-iron .475-inch platen plate, and one cast-iron .595-inch platen plate with tympan clamps attached. This combination is fitted for use with dies ¼ inch thick.

Half Medium,	13×19 inches inside chase	\$738 00
Half Super-Royal,	14×22 inches inside chase	800 00

STYLE No. 3, COMBINATION D.

For letterpress printing, printing on wood (not exceeding one inch in thickness) and cold embossing. This combination is fitted with a ¼-inch movable platen blank and a ¼-inch movable steel platen plate. Cutting and creasing can be done on this combination by adding a ¼-inch brass platen plate.

Quarto Medium,	10×15 inches inside chase	\$474 00
Half Medium,	13×19 inches inside chase	629 00
Half Super-Royal,	14×22 inches inside chase	679 00

BRUCE TYPE FOUNDRY, 13 CHAMBERS STREET, NEW YORK.

EVERYTHING FOR THE PRINTER.

PRICES OF GALLY UNIVERSAL PRESSES—Continued.

STYLE No. 3, COMBINATION E.

For letterpress printing, printing on wood (not exceeding one inch in thickness) and hot embossing, and all work that can be done on Combinations A, B and C. This combination is fitted with steam blank and pipe connections, 7/8-inch movable cast-iron platen blank, one .405-inch movable cast-iron platen blank, 1/8-inch steel platen plate, a movable steel plate on steam blank and a movable 1/8-inch brass platen plate.

Half Medium,	13×19 inches inside chase	\$738 00
Half Super-Royal,	14×22 inches inside chase	800 00

SPECIAL ADAPTATIONS.

Gauges and special appliances furnished for all No. 3 Presses to order at an extra cost. The No. 3 Presses will be built to order, specially adapted to any work for which they can be used, at a reasonable extra cost to the customer.

PRICE LIST OF ATTACHMENTS FOR GALLY UNIVERSAL PRESS.

	10×15 Press.	13×19 Press.	14×22 Press.
Ink fountain	\$20 00	\$25 00	\$25 00
Fountain partitions, each	4 00	4 00	4 00
Power fixtures on press only	10 00	10 00	10 00
Overhead fixtures, complete	25 00	30 00	30 00
Cast-iron chases	2 00	2 25	2 75
Wrought-iron chases	5 50	6 50	7 25
Roller stocks	0 60	0 65	0 75

SPECIAL FEATURES OF THE GALLY UNIVERSAL PRESS.

TWO TYPES OF PLATEN PRESSES.

The Universal Press, when invented and patented in 1869-70, differed radically both in its fundamental principles and labor-saving appliances from any other platen press in use at that time. Since then platen presses everywhere are divided into two recognized types or classes, each taking the name of the original inventor: the "Gordon" type, with its hinged or "clam-shell" movement of bed and platen, as imitated with slight variations under a great variety of names, all distributing ink by means of a disc, and the "Gally Universal" type, with its fixed bed, sliding platen, square impact of impression on the form, solid frame and cylindrical ink distribution.

IMPRESSION.

The ideal impression is given by a Washington Hand Press, and the impression given by the Gally Universal is similar, and is perfect in practice and in theory. No other type of platen press can give a perfectly square impression.

The platen is massive, and is secured to the platen bridge by four controlling screws which pass through the bridge, and is supported at the corners and in the center by five adjustable screw supports, giving nine supports in all. Thus the utmost strength and an unyielding impression is obtained.

The platen movement in relation to the bed is illustrated in Figs. 2 and 3 (sectional drawings from the inside).

Fig. 2 shows the platen open at the feeding position, supported by the rockers (*R*) on the slideways (*s*). The movement is controlled by the draw-bars, which connect with a steel shaft (*A*) passing through the platen bridge. As the draw-bars pull the platen toward the bed it rocks forward until the flattened toes (*e*) of the rockers rest on the slideways (*s*), as shown in Fig. 3.

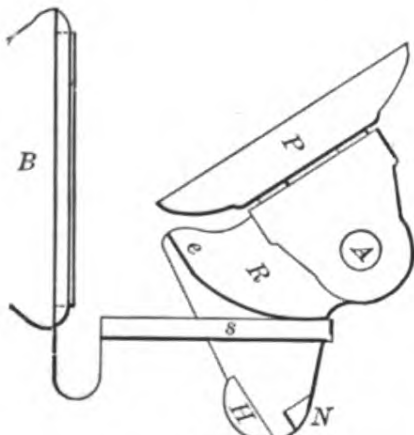

Fig. 2.

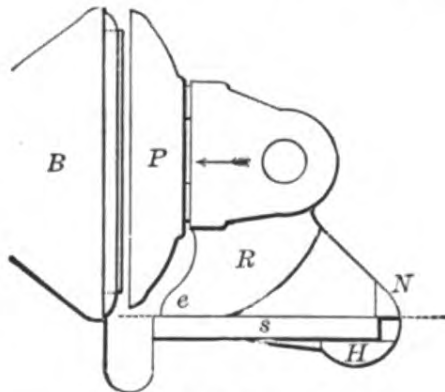

Fig. 3.

BRUCE TYPE FOUNDRY, 13 CHAMBERS STREET, NEW YORK.

EVERYTHING FOR THE PRINTER.

The platen is now half an inch from the type form, and exactly parallel to it, and the locking lugs (*N* and *H*) have engaged the slideways at top and bottom, preventing the platen from tipping. Thus secured, the platen slides squarely to the type form, taking a direct face impression. The platen then slides back and rocks to the feeding position again. The curve of the rockers (*R*) is struck from a point at the center of gravity of the whole moving piece, so that the movement is accomplished with a trifling expenditure of effort.

DISTRIBUTION OF INK.

The superiority of the Gally Universal Press is in no point more apparent than in the distribution and application of ink to the form. In Fig. 10 is shown the Gally Universal system of ink distribution. *C* is the main distributing cylinder, and *S* is the secondary distributing cylinder. The composition distributing rollers (*e* and *e'*) revolve on the distributing cylinders, and on top of the distributors are two metallic rollers (*v* and *v'*) with a steady lateral movement in opposite directions, constantly crossing and recrossing the lines of distribution. The ink is supplied from the fountain (*F*, Fig. 10) to the distributing cylinder (*C*), once at each impression, by the ductor roller (*H*), in an evenly spread line, immediately after the form rollers have left the cylinders to ink the form; and before the rollers have completed the rolling of the form and returned to the cylinders the applied ink is thoroughly distributed by the distributors (*e e'*), so that no undistributed ink can ever reach the form rollers or be applied to the form.

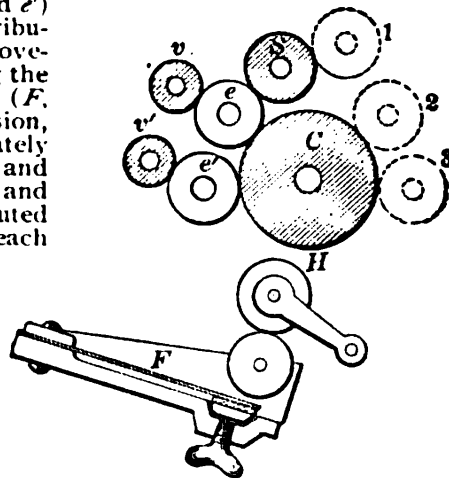

Fig. 10.

The distribution of ink is constant while the press is in motion, whether the form rollers (1, 2, 3) are in contact with cylinder or on the form. The cylinders, rollers and lateral distributors, as shown in Fig. 10, are made of different diameters on uneven measurements, so that their lines of contact are not repeated while revolving.

On presses with disc distribution the form rollers must distribute their own ink and convey it to the form, while on the Gally Universal these two functions are performed by two distinct sets of rollers. In the former case the work is necessarily imperfect; in the latter, both processes give perfect results.

INK FOUNTAIN.

The Gally Universal ink fountain is as complete as the ink fountain of any first-class cylinder press. Every part of it is under positive control. The movement of the fountain cylinder (*R*, Fig. 19) is regulated by a ratchet lever. The ink is carried from the cylinder (*R*) to the distributing cylinder *C*, Fig. 10, by a composition ductor roller. In nearly all ink fountains the regulating screws press directly against the steel blade, and in setting for a fine feed have a tendency to bind the fountain cylinder. In the Universal ink fountain (Fig. 19) *A* is a steel blade, *e* is rubber packing, and *a* is a very thin strip of steel against which the screws (*T*) are set. The rubber (*e*) furnishes an elasticity which prevents the blade from binding, while giving a perfect cut off. With this safeguard a press boy may be trusted to regulate the fountain. The fountain may be removed easily from the press to be cleansed, and is made interchangeable so that an extra fountain for colors may be put on in a few moments.

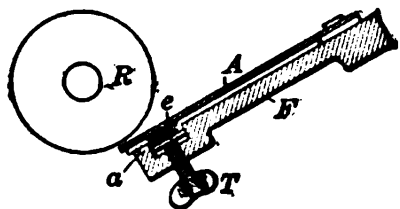
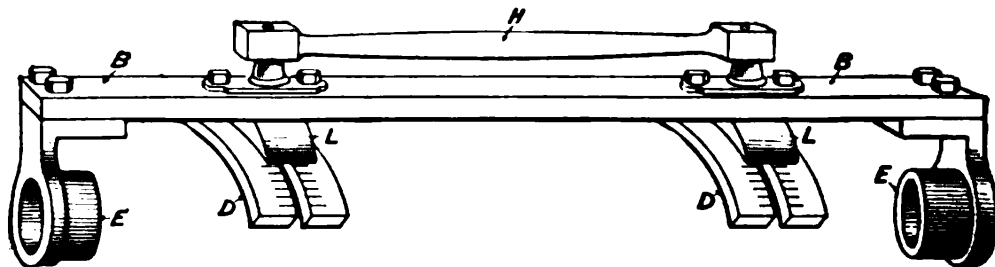

Fig. 19.

ADJUSTMENT OF IMPRESSION AND THROW-OFF.

The Gally Universal Press was the first to have a quick, easy method of adjusting the impression, and the Gally invention is still unexcelled. The theory of modern fine printing calls for a minimum of tympan packing, and to get this a fine adjustment of the platen impression is necessary. The labor as well as the inaccuracies of platen adjustment by means of the set screws make that method impracticable. Mr. Gally's invention is practically instantaneous, and allows of very fine adjustment or a total throw-off of the impression by the same device, which is located immediately behind the platen, in front of the pressman. The impression is regulated equally all over the surface of the platen by

means of the adjusterslides (*L*), which can be moved up or down, increasing or decreasing impression from a tissue paper's thickness to $\frac{1}{8}$ of an inch. These slides (*D*) are notched, and the latch, which is the lower end of



View of Impression Adjuster and Throw-off Bar, showing Notched Impression Adjuster Slides.

the throw-off handle (*H*), engages in this notch. When it is desired to throw off impression, the handle (*H*) is pulled, the latch is disengaged, and the adjuster bar (*BB*) drops down, carrying the platen back and preventing it from taking an impression.

EVERYTHING FOR THE PRINTER.

GALLY UNIVERSAL EMBOSSING PRESS.

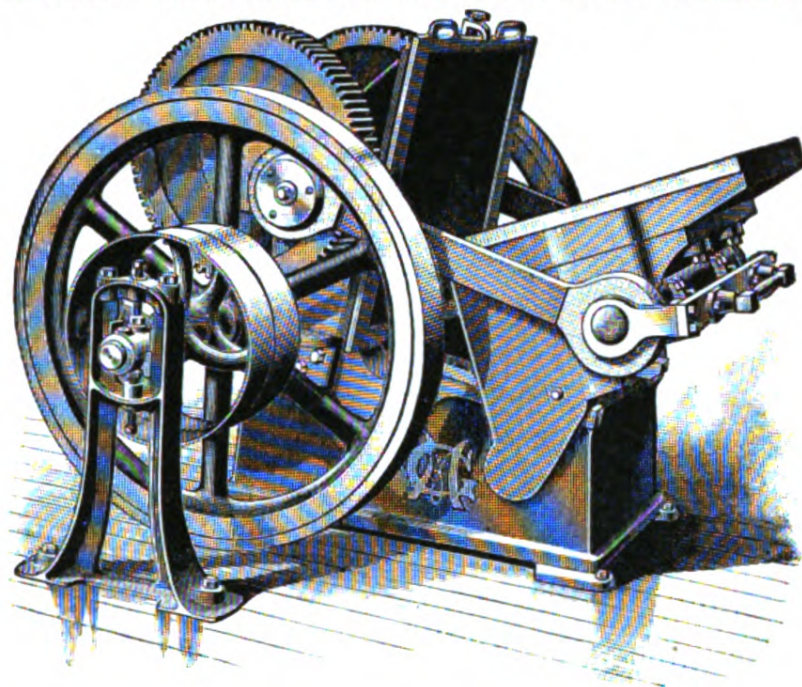

These are the largest embossing presses made, and combine strength, power, speed and facility for handling work easily in a degree unequaled by any other press. They are designed for extra heavy hot or cold process embossing, and book-cover stamping ("smashing"). The mechanical principles employed to give impression, power, and to throw-off impression, are the same as described on pages 499 and 500. Nothing better demonstrates the correctness of the mechanical principles on which Gally Universal Presses are built than their applicability to all degrees of power and strain. Every other type of platen press has its limitations—a point where it gets unwieldy and inefficient.

PRICES OF PRESS ONLY.

No. 1.	21 1/4 X 22-inch bed-plate, 18 X 20 -inch chase	\$800 00
No. 2.	24 X 26-inch bed-plate, 22 3/8 X 24 5/8-inch chase	900 00

PRICES OF EXTRA ATTACHMENTS.

Steam blank, complete, with pipe connections, for No. 1 Embosser, with steel die plate	\$105 00
Steam blank, complete, with pipe connections, for No. 2 Embosser, with steel die plate	118 00
Steel platen plate for No. 1 Embosser	19 50
Steel platen plate for No. 2 Embosser	26 00
Cast-iron platen blank for No. 1 Embosser	19 50
Cast-iron platen blank for No. 2 Embosser	26 00
Gas blank	200 00

Each press is complete with power fixtures on press.
 Each press is furnished with three chases (or one cast-iron bed blank in lieu of chases, at option of purchaser), two feed tables, one wrench, one belt-shifter and one brake.
 Gross weight, boxed, of embossing presses are: No. 1, 3400 pounds; No. 2, 4300 pounds.
 Boxing for export: No. 1, \$10 00; No. 2, \$15 00—net.
 Prices are f. o. b. factory.

GALLY UNIVERSAL STAMPING PRESS.

This is a very powerful press, built especially for stamping book covers, making signs and photo-mounts. The only fast-running press made that is sufficiently powerful to do this kind of work satisfactorily. Speed at least 1800 impressions per hour.

Size of bed, 24 X 26 inches	\$1600 00
---------------------------------------	-----------

FOR HOT WORK.

Steam blank	\$150 00
Gas blank	200 00

BRUCE TYPE FOUNDRY, 13 CHAMBERS STREET, NEW YORK.

EVERYTHING FOR THE PRINTER.

**GALLY UNIVERSAL PAPER-BOX CUTTING AND
CREASING PRESS.**

(See "Paper Box Making" at foot of this page.)

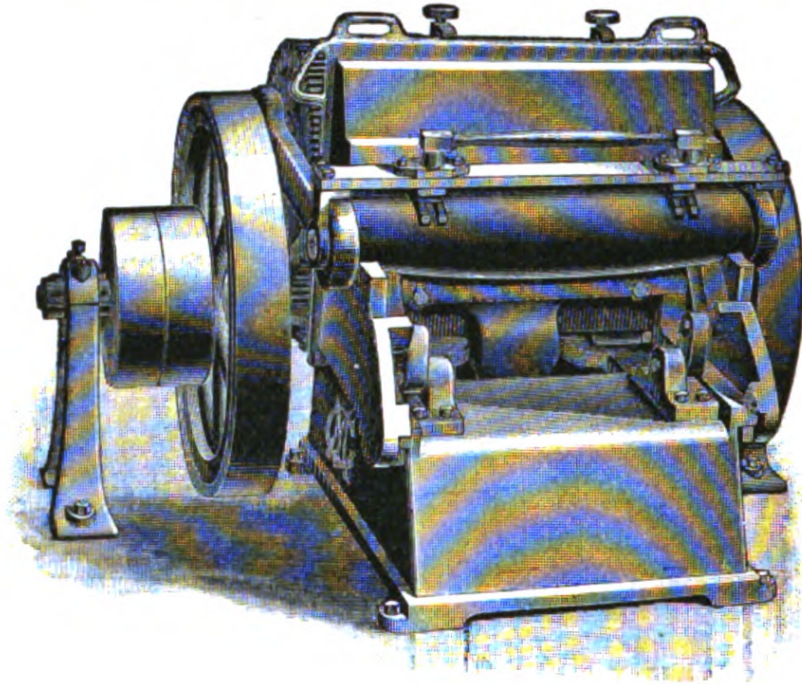

This is the only Cutting and Creasing Press on which the cutting form can be placed "out of center" without injury to the cutting rule or detriment to the work. Mr. Gally's latest patented improvement on these presses holds the platen to perfect register on an unbalanced form. This is a very important matter, as is fully understood by all those engaged in the manufacture of folding paper boxes and similar articles.

PRICES.

With Brass Platen Plate and Power Fixtures on Press.

No. 1.	22 × 31 ¼-inch bed-plate, 20 × 30 -inch chase	\$700 00
No. 1 ½.	24 ¼ × 31 ¼-inch bed-plate, 22 ½ × 30 ¼-inch chase	800 00
No. 2.	25 × 33 -inch bed-plate, 23 ¼ × 31 -inch chase	900 00
No. 4.	27 ½ × 41 ½-inch bed-plate, 27 × 40 -inch chase	1200 00

Prices are f. o. b. factory.

Each press is furnished with a ⅛-inch brass platen plate, three chases, two feed tables, one wrench, one belt-shifter and one brake.

Boxing for export: Nos. 1 and 1 ½, \$15 00; Nos. 2, and 4, \$20 00, net.

See page 993 for Extra Heavy Overhead Fixtures for Embossing and Cutting and Creasing Presses.

FOLDING PAPER BOX MAKING.

The process of making folding paper boxes is simple. The stock used is manilla board, made specially for the purpose. A cutting and creasing press is the same as an ordinary printing press, except that it is larger, has to be stronger, and does not require an inking apparatus. The shape of a box having been decided on, a form is set up with steel cutting and brass creasing rules—the former to cut out waste margins and to make slits, and the latter to crease or score the lines on which the stock in the box must bend when set up for use. It is usual to cut and crease as many boxes at one time as can be cut out from a full-sized sheet. The box leaves the press flat. It is then folded once and glued on one edge, and delivered flat. Any printing required is done before cutting and creasing. Any good compositor will understand the process after reading above explanation and examining a folded paper box. The glueing is done by a machine of moderate cost.

BRUCE TYPE FOUNDRY, 13 CHAMBERS STREET, NEW YORK.

EVERYTHING FOR THE PRINTER.

THE "PEERLESS" PRESS.

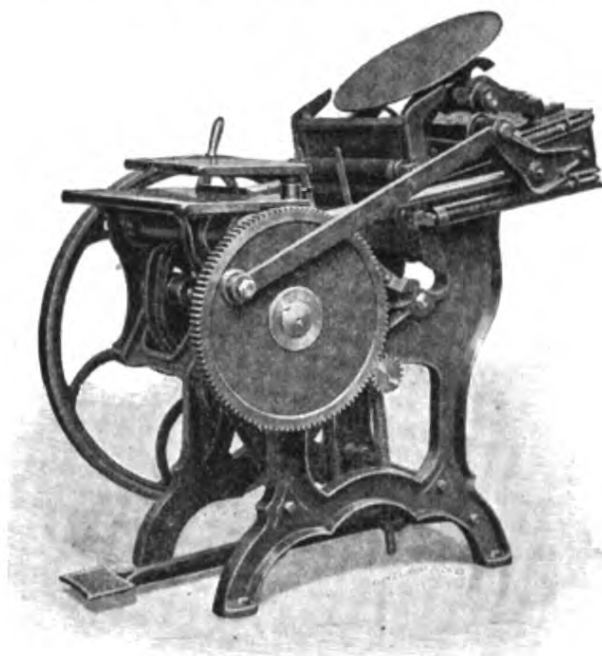

Of well-established reputation, smooth running, noiseless, easy to make-ready on, easy to feed, easy to run by treadle, with an effective throw-off, well built, exceptionally strong, and with a powerful toggle movement. The throw-off is positive and easy, and convenient to handle. The platen is sustained in the center by the toggle, and is strongest where platens are generally weakest, enabling the Peerless to do embossing and paper-box cutting and creasing, which tax a press very severely. It is a fast press.

Eighth Medium	8	× 12 inches inside chase	\$225 00
Large Eighth Medium	9	× 13 inches inside chase	250 00
Quarto Medium	10	× 15 inches inside chase	300 00
Large Quarto Medium	11	× 17 inches inside chase	350 00
Half Medium	14	× 20 inches inside chase	450 00
Half Super-Royal	14½	× 22 inches inside chase	500 00
Pony Ink Fountain, for Eighths and Quartos			10 00
Hinged-Well Ink Fountain, all sizes			25 00
Power fixtures on press, all sizes			15 00

WRITE FOR NET PRICES.

Three chases, one impression wrench, one brayer, two sets roller trucks, one set of cast rollers, and one extra set of stocks are furnished with each press.

If desired, will send roller mould or two extra chases instead of covering one set of stocks with composition.

CHASES FOR "PEERLESS" PRESSES.

	Cast Iron.	Steel.		Cast Iron.	Steel.
8×12 inches inside	\$1 25	\$3 00	11 × 17 inches inside	\$2 00	\$5 00
9×13 inches inside	1 50	3 50	14 × 20 inches inside	2 50	5 75
10×15 inches inside	1 50	4 50	14½ × 22 inches inside	3 00	6 00

SECOND-HAND PRESSES.

As a rule, second-hand presses of all makes and sizes can be supplied. Special lists of these are issued at short intervals. Those in want of second-hand machinery are invited to correspond with us. Time will be saved if correspondents will state exactly what they require.

BRUCE TYPE FOUNDRY, 13 CHAMBERS STREET, NEW YORK.

EVERYTHING FOR THE PRINTER.

PILOT HAND LEVER PRESS.

6½ × 10 inches inside chase \$35 00
 Ink fountain 10 00

One chase, one set of covered rollers, and one wrench supplied with each press.

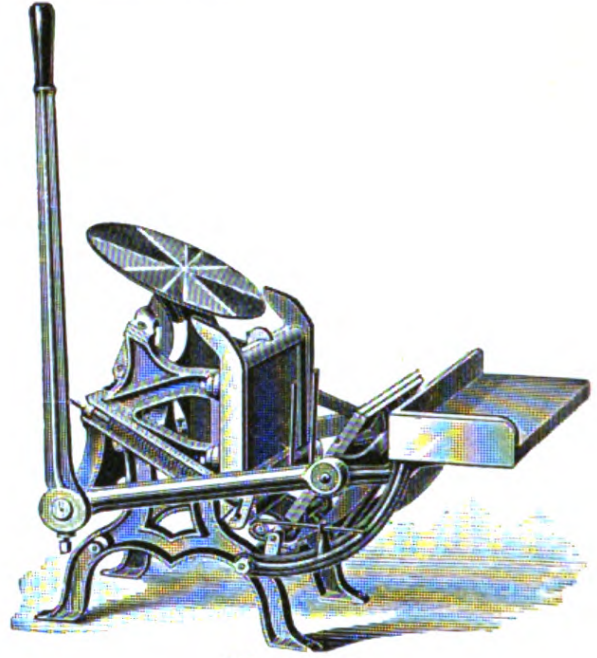

Pilot Press.

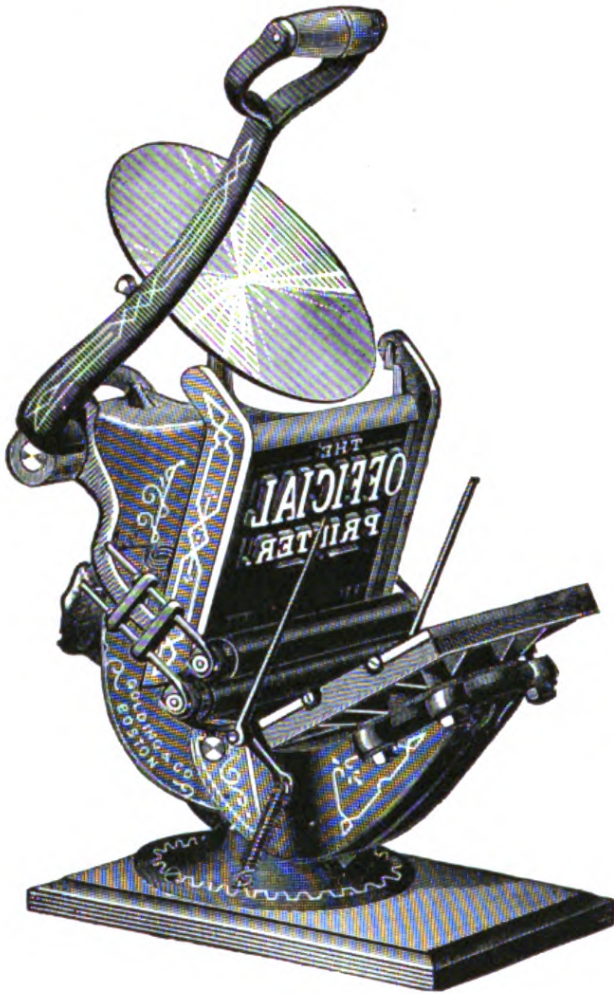

**OFFICIAL
 HAND LEVER PRESSES.**

No. 3. 5 × 7½ inches inside
 chase \$25 00
 No. 4. 6 × 9 inches inside chase . . 35 00
 No. 6. 8¼ × 12½ inches inside
 chase 60 00

One chase, one set of covered rollers and one wrench supplied with each press.

ACME METAL EXTENSION FURNITURE.

Designed to save time in locking up forms for job presses. It is quickly handled, and is adjustable according to Picas, extending from two and one-quarter to four inches. When locked up it is perfectly secure.

Price, per set of four . . . \$1 50
 Per dozen (three sets) . . 4 00

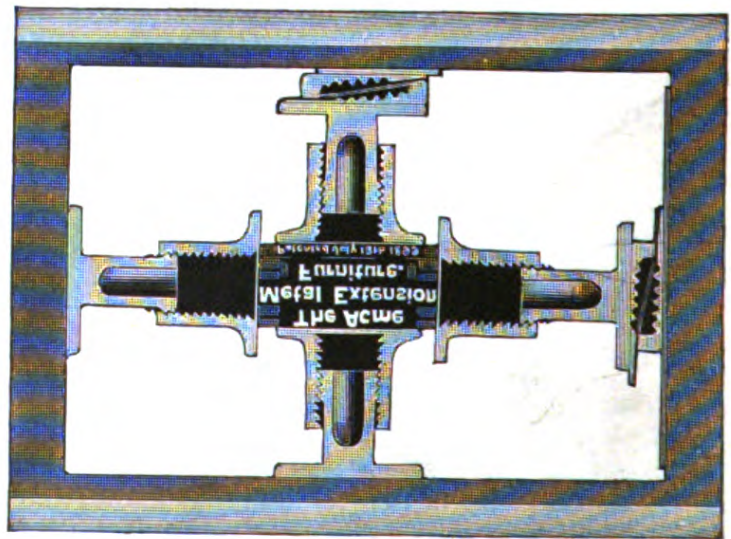

BRUCE TYPE FOUNDRY, 13 CHAMBERS STREET, NEW YORK.

EVERYTHING FOR THE PRINTER.

THE CRANSTON PRESSES.

These presses have always been built on high-grade lines. The motto of the maker, painted conspicuously in the factory, "First learn to do a thing well, then learn to do it quickly," has been consistently carried out, and it can safely be affirmed that the Cranston presses are unexcelled in fine workmanship, true mechanical principles, and superior materials, all which result in durability, smoothness, and general satisfaction. The new series of 1897 have numerous up-to-date improvements, and some sizes have been changed for the better convenience of printers. The numerous users of Cranston presses will be more than pleased with the new series.

THE CRANSTON NEWSPAPER PRESS.

**Two-Roller,
With Rack and Pinion Distribution.**

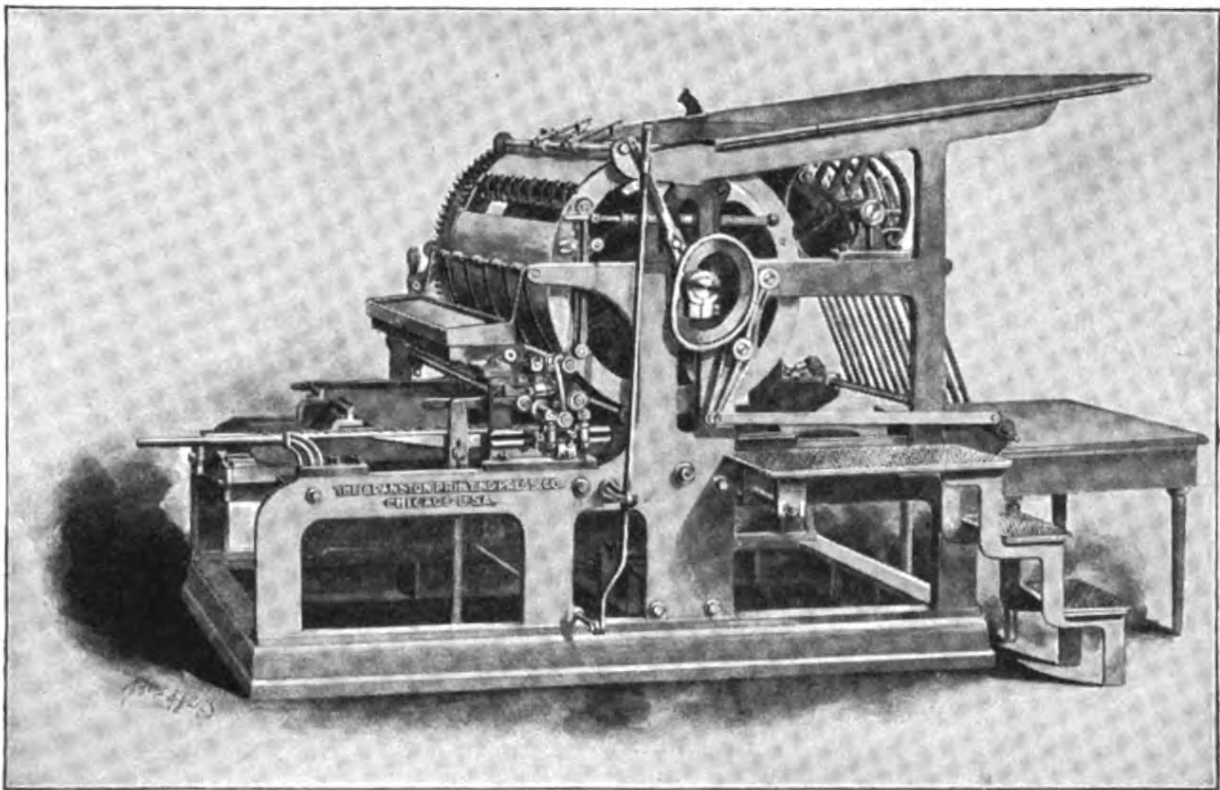

Built of the best material; furnished at a moderate price; put to practical tests;—it has proved by constant use to be an economical press to buy. The runners on both track and table are steel; the shafts, rolls, studs, shoes and wearing parts are also steel. All gears and racks are cut from the solid. The press is provided with air springs, tapeless delivery, noiseless gripper motion, continuous fly cam, adjustable feed guides. The fountain is placed high on the stand, thus giving easy access to bed of press. The form rolls are made of wrought iron pipe, and are of large size, easily placed in position and adjusted. There is a brake, a fountain cover, reel rod for blanket and tympan, and a guard for distributing rack.

Size.	Inside Bearers.	Matter Covered.	Length of Base.	Width of Base.	Weight Boxed.	Price.
No. 3½ . . .	33×48 . . .	28×44 . . .	7 ft. 7½ in. . . .	5 ft. 3½ in. . . .	9000 lbs. . . .	\$1600 00

An additional charge for table distribution.

Each press is furnished with overhead fixtures complete (except when furnished with hand power only), blanket, wrenches and one set stocks, cast ready for use, also one extra set stocks and iron steps.

BRUCE TYPE FOUNDRY, 13 CHAMBERS STREET, NEW YORK.

EVERYTHING FOR THE PRINTER.

THE CRANSTON IMPROVED NEWSPAPER PRESS.

Two-Roller, with Rack and Pinion Distribution.

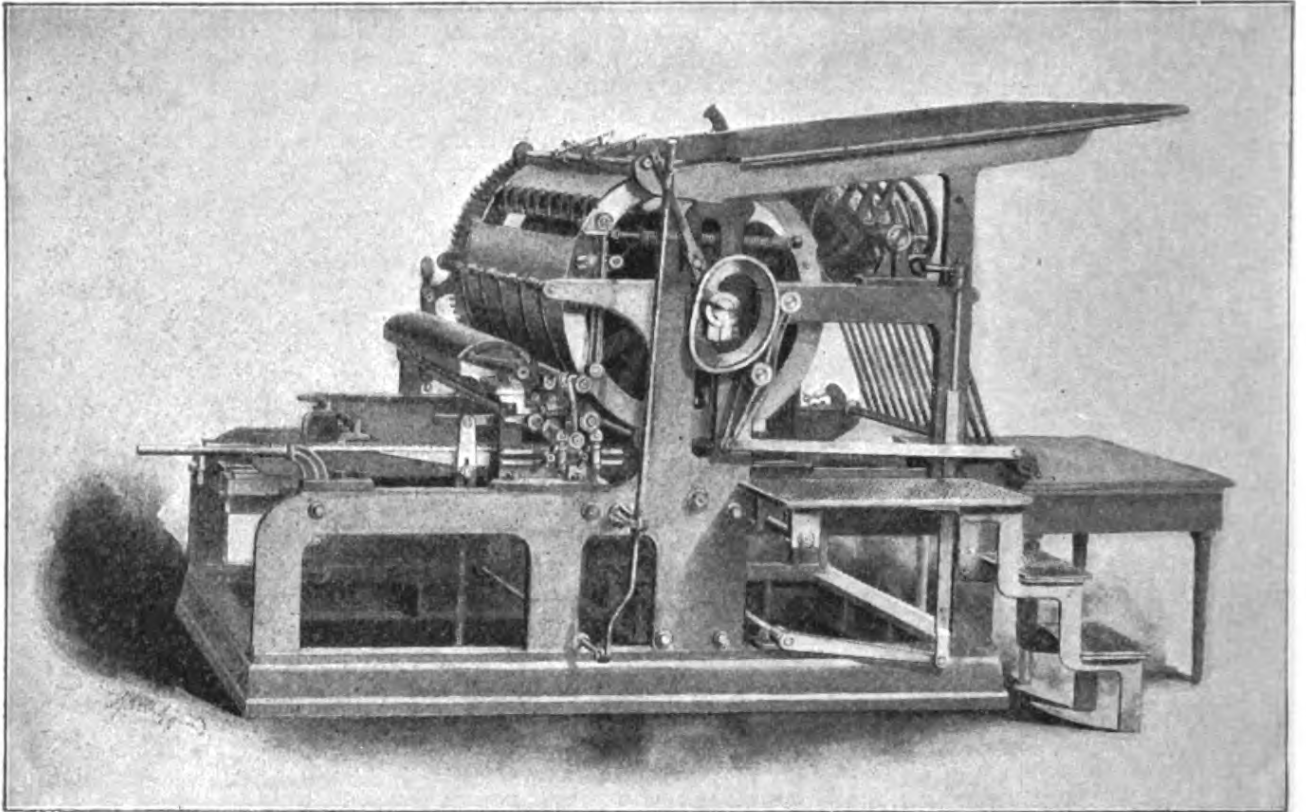

The Improved Newspaper Press has been materially changed in construction and general appearance. All racks and gears have wide faces, and are cut from the solid. The press has air springs; tapeless delivery—wheels adjustable to any size sheet; patented device for controlling motion of sliders; patent stop and reversing motion; noiseless gripper motion; continuous fly cam; feed guides that are capable of the finest adjustment; large size form rollers; long register rack and segment; deep fountain; cover for fountain; convenient arrangement for adjusting fountain roll; cylinder distribution.

Every convenient feature that the price at which it is offered will permit is put on this press, effecting a saving of time and labor for which the Cranston presses are well and favorably known.

Size.	Inside Bearers.	Matter Covered.	Length of Base.	Width of Base.	Weight Boxed.	Price.
No. 3½	33×48	28×44	7 ft. 7½ in.	5 ft. 3½ in.	9500 lbs.	\$1800 00

Table distribution extra.

Each press is furnished with overhead fixtures complete, blanket or hard packing, wrenches, iron steps, two complete sets stocks—one set cast with composition ready for immediate use.

THE CRANSTON IMPROVED BOOK AND NEWSPAPER PRESS.

Two-Roller, with Rack and Pinion Distribution.

The Improved Book and Newspaper Press has all of the features which made the Improved Newspaper Press the best newspaper press in the market, and in addition has a separate heavy cast-iron base plate which gives additional strength and solidity to the machine, and makes it possible to run it at a higher rate of speed without jar or injury to the press. It is especially designed for fine book, newspaper and general job printing. For accuracy of register and convenience of making ready it is unexcelled. The workmanship and wearing qualities are unsurpassed.

Size.	Inside Bearers.	Matter Covered.	Length of Base.	Width of Base.	Weight Boxed.	Price.
No. 3½	33×48	28×44	7 ft. 7½ in.	5 ft. 3½ in.	10,000 lbs.	\$2200 00
					Table distribution, extra	100 00

Each press is furnished with overhead fixtures complete, blanket or hard packing, wrenches, iron steps, two complete sets stocks—one set cast with composition ready for immediate use.

BRUCE TYPE FOUNDRY, 13 CHAMBERS STREET, NEW YORK.

EVERYTHING FOR THE PRINTER.

**THE CRANSTON PATENT IMPROVED TWO-ROLLER.
PRINTING PRESS.**

For Fine Book, Commercial and Newspaper Printing.

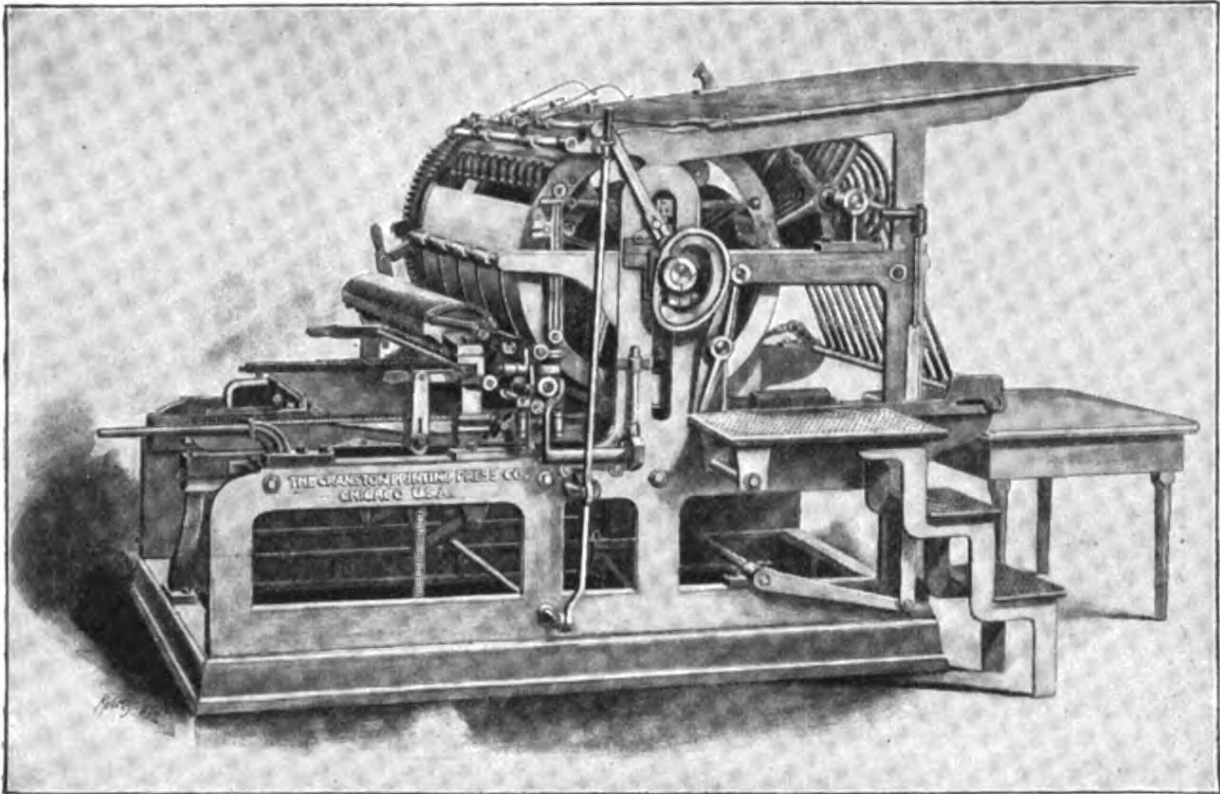

This press is carefully made in every detail. The stock and finish are unexcelled. The tracks are wide, and provided with steel rolls and runners. The wearing parts—shafts, knuckles, shoes, studs—are of steel. The gears and racks are cut from the solid, and have wide faces. The press has air springs; patent silent slider motion, which insures uniform travel of the sliders with the table; patent stop and reversing motion; improved feed guides; patent adjustable side-guide leaf on feed table, which can be set for the greatest precision of register.

The fly is operated by a silent motion, the cam having a continuous surface.

The fountain basin is deep, and will carry a large supply of ink. It is placed high on the stands, and easy access is thus given to the bed of the press.

The Cranston combines the essential features: great strength, unyielding impression, fine distribution, exact register, with convenience in adjustments and make-ready. It is operated with light power, and cannot but give satisfaction both in quantity and quality of work produced.

Size.	Inside Bearers.	Matter Covered.	Length of Base.	Width of Base.	Weight Boxed.	Price.
*No. 1	21 × 28	16 × 24	5 ft. 8¾ in.	3 ft. 8¼ in.	5,500	—
*No. 1½	21 × 36	16 × 32	5 ft. 8¾ in.	4 ft. 4½ in.	6,500	—
*No. 1A	24 × 30	19 × 26	6 ft. 2½ in.	3 ft. 10¼ in.	6,500	—
No. 2A	25 × 38	22 × 34	6 ft. 8¾ in.	4 ft. 7¾ in.	8,500	—
No. 2½	29 × 43	24 × 39	7 ft. 4½ in.	5 ft. —	10,000	—
No. 3½	33 × 48	27 × 44	7 ft. 9¾ in.	5 ft. 5 in.	11,000	—

*Commercial Series.

Each press is furnished with overhead fixtures complete, blanket and hard packing, wrenches, iron steps, and two complete sets stocks—one set cast with composition and ready for immediate use.

BRUCE TYPE FOUNDRY, 13 CHAMBERS STREET, NEW YORK.

EVERYTHING FOR THE PRINTER.

THE CRANSTON-VICTOR COMMERCIAL PRESS.

Two-Revolution, with Four Rollers.

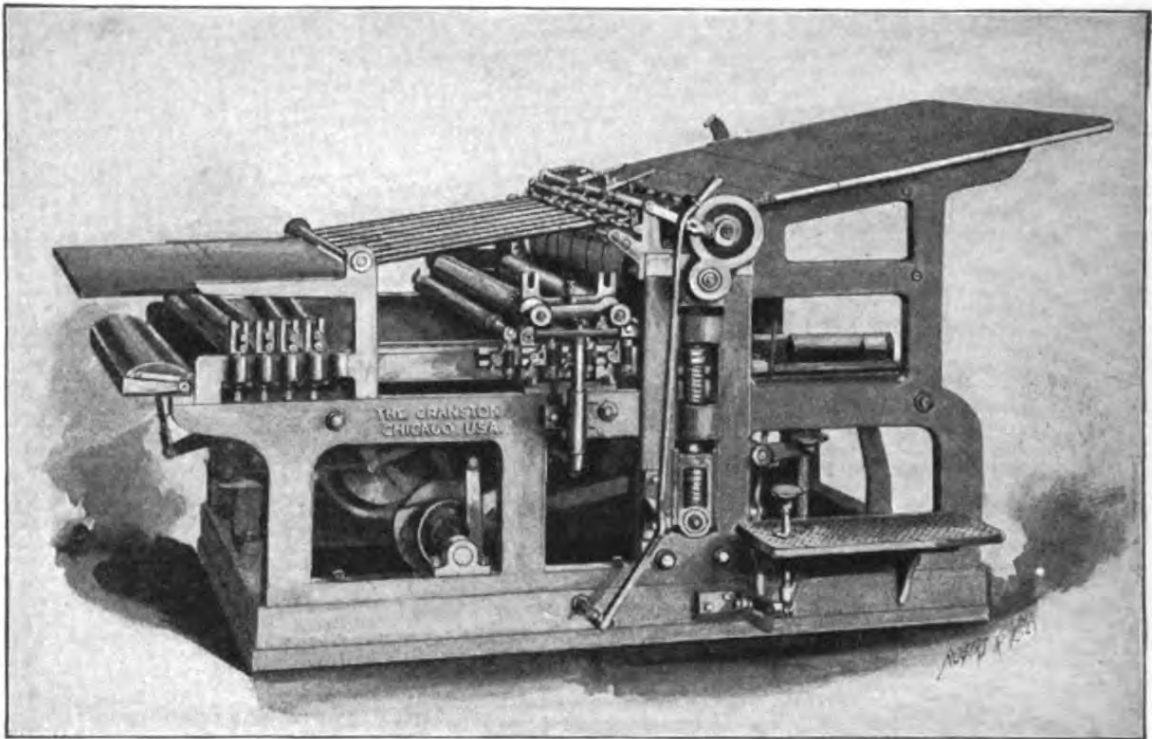

Various methods of engraving having been developed, and their utility practically demonstrated, the demand has been created for a press that will bring out delicate lines of half-tone, process, etched, photo-engraved plates, and work of this description, giving that clear and distinct impression without which the best results are not attainable from such plates. The new Victor Two-Revolution Four-Roller Commercial Press is especially designed for this class of work. Possessing as it does the patented features of our larger sizes, it is, like them, solidly constructed, giving an *unyielding impression* and an *ample inking surface*. Its size is convenient and sufficiently large to meet all demands for work of this class, while the speed provides for rapid production. Many features are embodied in this press for convenience in make-ready, etc. The distribution is a complete system, by means of which every particle of inking surface is *evenly* and *thoroughly* covered. The movements are easily adjusted and positive in their action. The cam has a continuous surface, and the sheets are laid lightly on the table without smut or off-set. Adjustable fly-fingers. The height of the press is such that it can be fed from the floor, and it is built with special reference to convenience in working about it. Its register is *faultless*. This press is the result of careful study, and embodies suggestions from practical printers regarding the requirements for printing this special work. The very satisfactory results obtained from those in use prove conclusively that the Victor will meet all requirements made upon it.

The speed is equal to all reasonable demands for fine printing.

Size.	Inside Bearers.	Matter Covered.	Length of Base.	Width of Base.	Weight Boxed.	Price.
No. 2A . .	26×38 in. .	21½×34 in. .	6 ft. 5¼ in. .	4 ft. 5¼ in. .	7500 lbs. . .	_____

Each press is furnished with overhead fixtures complete, blanket or hard packing, wrenches, two complete sets stocks—one set cast ready for immediate use.

A WISE PURCHASE.

The No. 2A Cranston-Victor Press is a money-maker. Fine job printing, from small circulars to any size within its capacity, can be done at high speed and with the finest results. In a printing establishment doing general work of all grades this press will prove exceedingly useful and profitable. Its construction and features are such that making ready can be done quickly. It takes in a great range of work which cannot be so profitably printed on a larger press.

BRUCE TYPE FOUNDRY, 13 CHAMBERS STREET, NEW YORK.

EVERYTHING FOR THE PRINTER.

CHALLENGE COUNTRY CYLINDER PRESS.

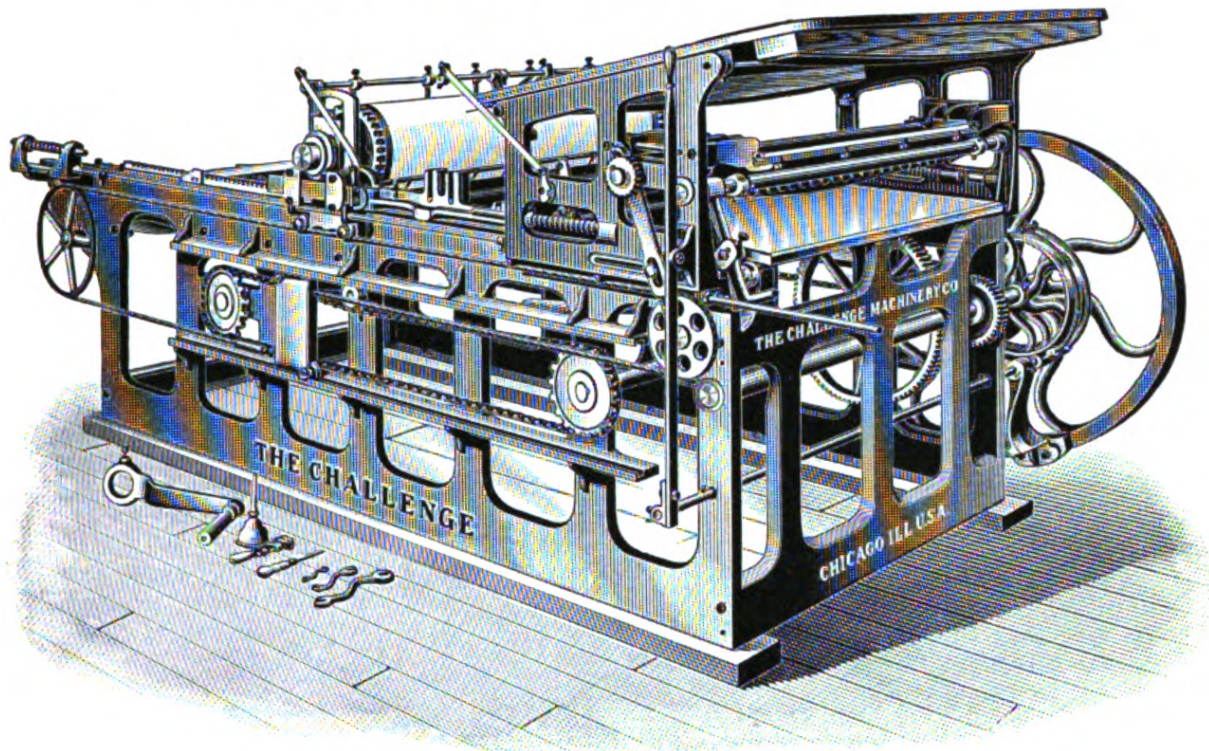

HAND-POWER SERIES.

	Size of Paper.	Size of Bed.	Shipping Weight.	Price.
No. 1.	6-column quarto	33×47½	3500 lbs.	\$500 00
No. 2.	7-column folio	27×38½	2800 lbs.	450 00

STEAM-POWER SERIES.

	Size of Paper.	Size of Bed.	Shipping Weight.	Price.
No. 11.	6-column quarto	33×47½	4500 lbs.	\$600 00
No. 12.	7-column folio	27×38½	3750 lbs.	550 00

Prices quoted are f. o. b. Chicago.

ARMY PRESS.

This is the lowest-priced press on which a newspaper of small circulation can be printed. The cylinder is stationary, but adjustable for impression by regulating screws at each end. The bed and form pass under the cylinder, and an impression is taken at each forward and backward movement.

Each press is furnished with two chases, patent quoins and key, side and foot sticks, roller frame and cast roller, oiler and wrench.

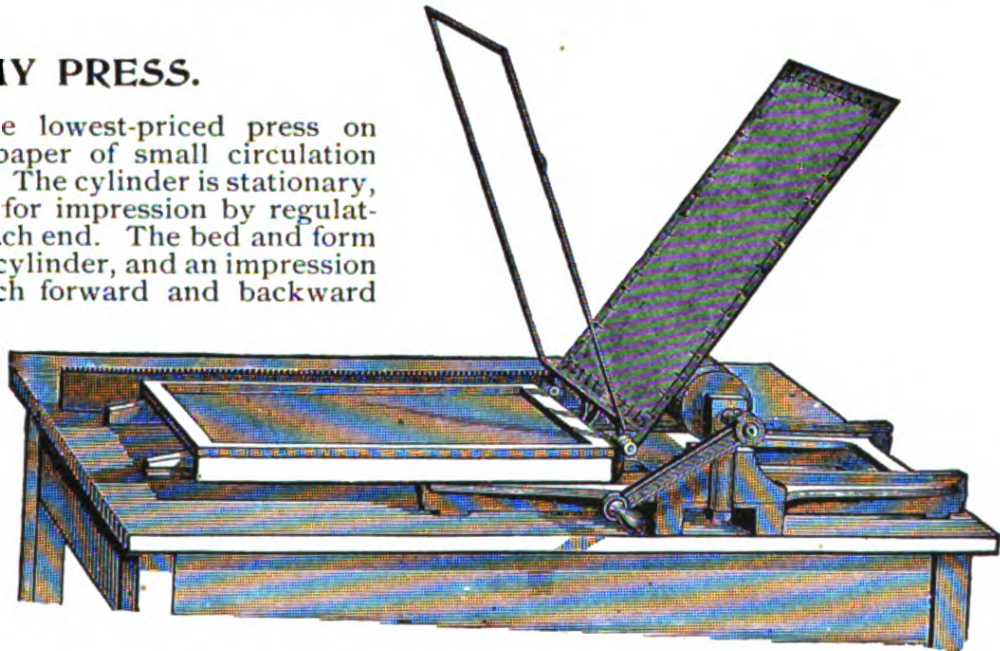

To print one page, 6-column folio, 14 5/8 × 20 1/2 inches	\$ 60 00
To print one page, 7-column folio, 16 7/8 × 22 7/8 inches	85 00
To print one page, 8-column folio, 19 1/4 × 25 1/2 inches	120 00
To print two pages, 5-column folio, 19 1/2 × 26 inches	125 00

BRUCE TYPE FOUNDRY, 13 CHAMBERS STREET, NEW YORK.

EVERYTHING FOR THE PRINTER.

IMPROVED COUNTRY PROUTY PRESS.

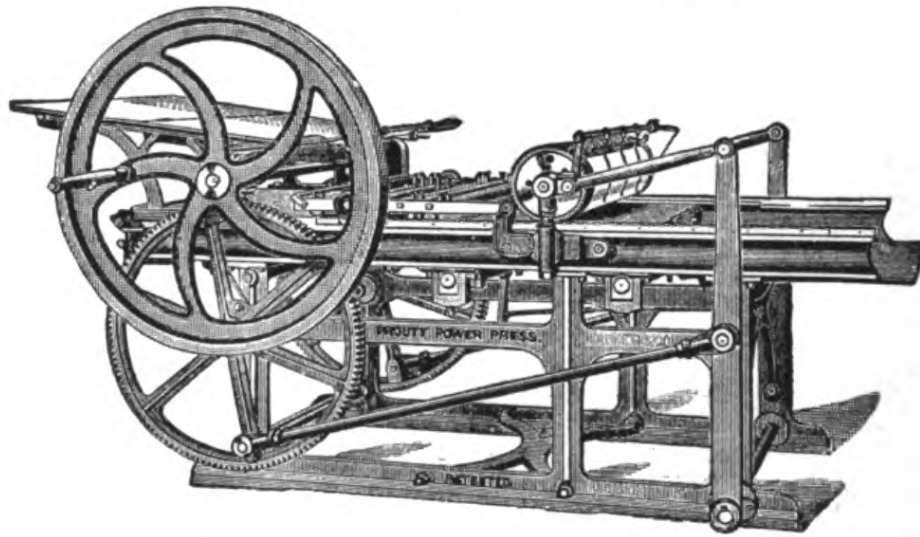

Square sides, patent square drop bed and throw-off. Self-inking. The cylinder rolls over the type form after taking the sheet from the feed-board. The rollers follow the cylinder over the type form. The cylinder is actuated by geared wheels which act on levers connecting at each end of cylinder.

	Size, inside bearers. Inches.	Weight. Pounds.	
No. 1. 7-column folio	27 × 37	3600	\$600 00
No. 2. 8-column folio	27½ × 43½	4000	700 00
No. 3. 6-column quarto	32½ × 46½	4600	800 00

The above prices include well fountain, rubber blanket, set of cast rollers, set of extra cores, and patent throw-off and impression lock. All boxed and on board cars. Steam fixtures, \$15 00 extra.

NEW LEVERLESS MONONA PRESS.

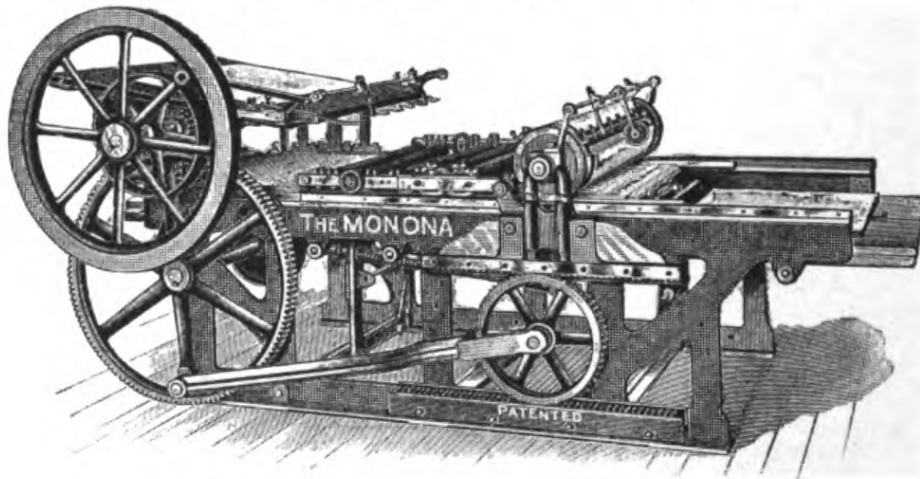

Similar in principle to Improved Country Prouty Press illustrated above, but more substantial in construction and without cylinder levers. The cylinder is held to the rails by a new double spindle cross-head. The cylinder is actuated by geared wheels running in racks.

	Newspaper Press.	Book and Job Press.
7-column folio	\$700 00	\$750 00
8-column folio	800 00	850 00
6-column quarto	900 00	950 00
7-column quarto	1050 00	1100 00

Each press sold with full set cast rollers, and blanket on cylinder. No charge for boxing. Steam fixtures, extra, \$15 00. Screw vibrators on top of form rollers, extra, \$15 00.

BRUCE TYPE FOUNDRY, 13 CHAMBERS STREET, NEW YORK.

IDEAL HAND CYLINDER PRESS.

The type form on this press is stationary. The cylinder is moved over the tympan by link belts running over sprocket wheels at each end of the press, and it prints a sheet at each forward or backward movement. The cylinder is made of steel, and is held firmly to the tracks by truck-wheels which run in a groove on the under side of the tracks. The boxes which hold the cylinder at each end, and in which it revolves, are connected by a stretcher rod running above the cylinder, which prevents side friction. The impression is regulated by four screws—two on each side—which raise or depress the bearers on which the cylinder runs. An effective inking apparatus is supplied, but is extra. A number of Ideal Presses are in use, and intending purchasers may gather how satisfactory they are to the users by reading the following extracts from a great many commendatory letters received:

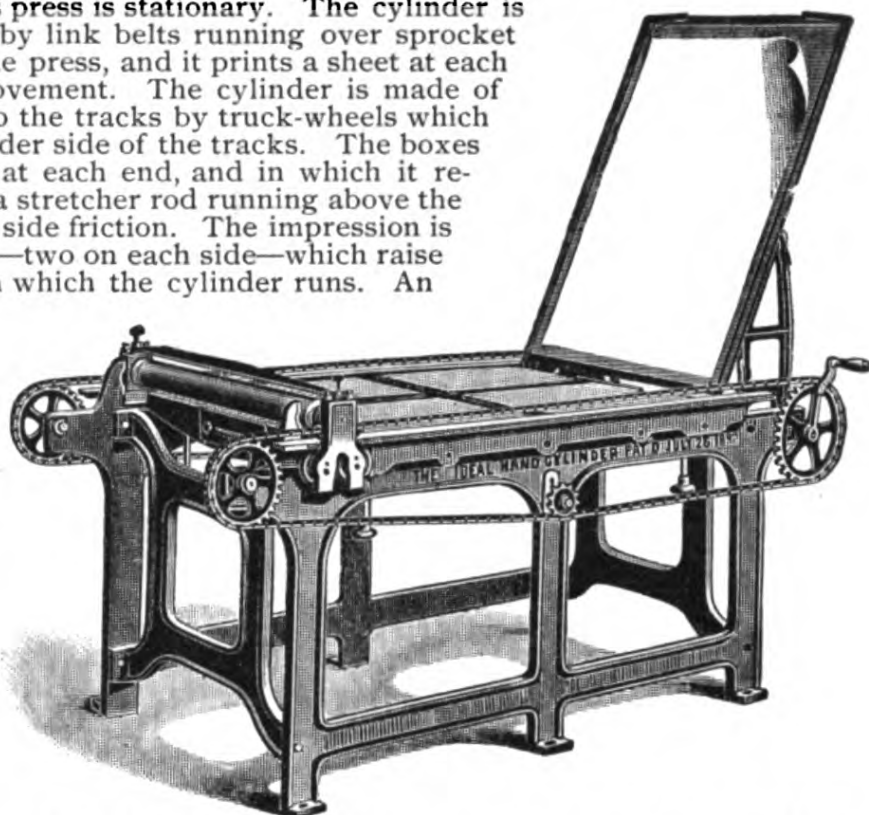

"My wife ran off 300 an hour on it the first day it was put up." * * * "With it our inexperienced pressman has made the following speed: 750 impressions in 75 minutes; 475 in one hour; 100 in 11 minutes. We run a regular lick of 100 every 15 minutes, or 400 per hour." * * * "The press is so simple that the veriest novice can set it up, and so light-running that a boy may operate it with ease." * * * "It is far superior to my old Washington for speed and quality of work."

- No. 1. 8-column folio or 5-column quarto, size of bed, 28½×43 inches \$200 00
 - No. 2. 9-column folio or 6-column quarto, size of bed, 33½×48¼ inches 225 00
 - No. 1. Floor space, 31×55. Weight, 700 pounds. Shipping weight, 975 pounds.
 - No. 2. Floor space, 35×60. Weight, 800 pounds. Shipping weight, 1100 pounds.
- Frisket for either size, furnished to order only, \$6 00. Extra tympan, covered, for either size, \$7 00.

IDEAL INKING APPARATUS.

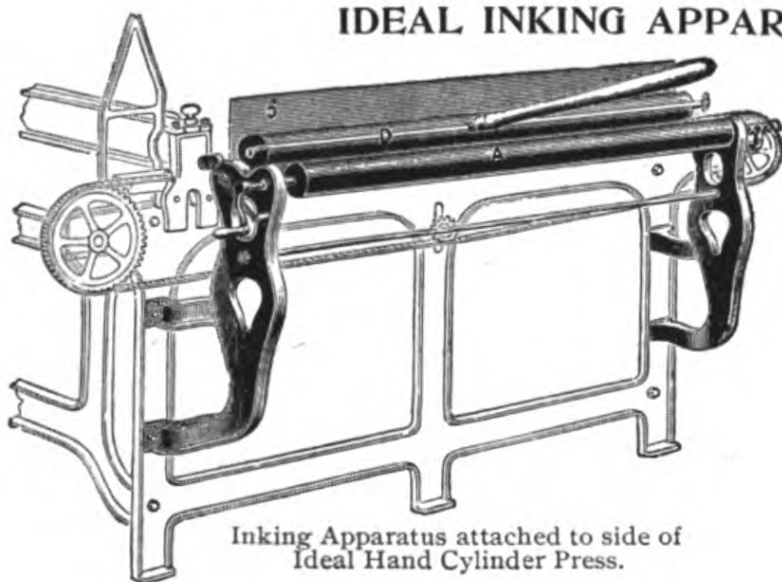

Inking Apparatus attached to side of Ideal Hand Cylinder Press.

There are two inking cylinders (A and B), one of which (A) revolves by means of the hand crank, and while revolving it automatically vibrates. The inking roller (D) rests on the inking cylinders and receives its supply of distributed ink. When the roller (D) is pushed toward the form, the automatic sheet-steel drop-leaf ink table (C) descends on the bed of the press and the roller (D) passes easily on to the type form. When the roller returns, the ink table (C) resumes its perpendicular position automatically. The Ideal Inking Apparatus is not furnished with the Ideal Press unless specially ordered.

- No. 1, for 8-column folio or 5-column quarto . \$30 00
- No. 2, for 9-column folio or 6-column quarto . 32 00

Hand Roller with Two Handles, including Extra Core:

- No. 1. 20 inches long, for 8-column single page \$3 75
- No. 2. 22 inches long, for 9-column single page 4 25

EVERYTHING FOR THE PRINTER.

WASHINGTON
HAND
PRESS.

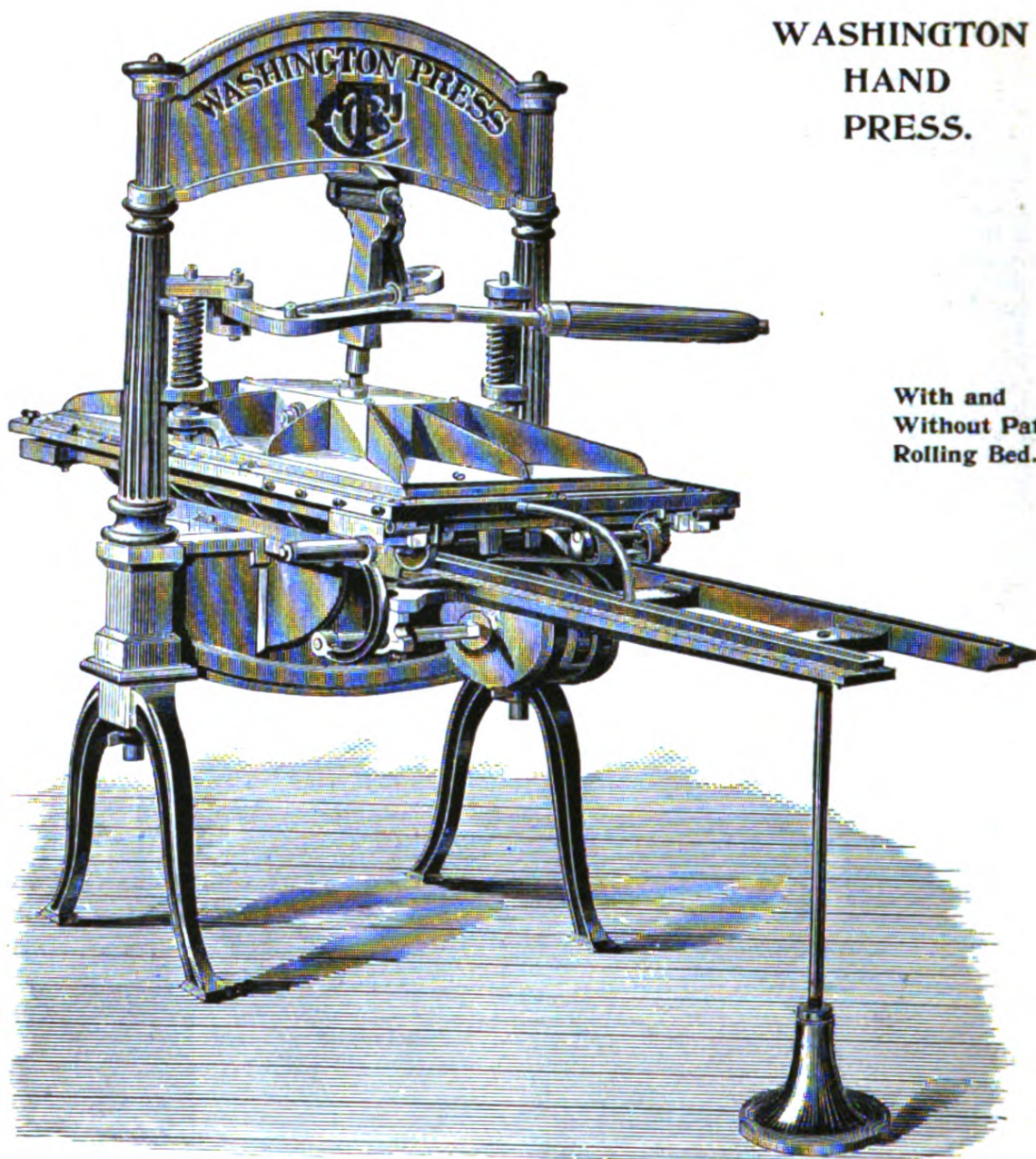

With and
Without Patent
Rolling Bed.

Platen.	Bed.		
14×18 inches . . .	17 ×21 inches . . .		\$150 00
16×21 inches . . .	20 ×25 inches . . .		175 00
20×25 inches . . .	24 ×29 inches . . .		200 00
23×31 inches . . .	25½ ×34¾ inches, for 6-column folio . . .		200 00
23×35 inches . . .	26½ ×39 inches, for 7-column folio . . .		225 00
25×39 inches . . .	28½ ×42 inches, for 8-column folio or 5-column quarto . . .		250 00
27×43 inches . . .	31½ ×47½ inches, for 9-column folio . . .		275 00

WITH PATENT ROLLING BED.

The patent rolling bed runs on rollers instead of sliding, and thus much exertion is spared the pressman, and the work is done quicker.

Platen.	Bed.		
23×35 inches . . .	26½ ×39½ inches, for 7-column folio . . .		\$250 00
25×39 inches . . .	28½ ×43½ inches, for 8-column folio or 5-column quarto . . .		275 00
27×43 inches . . .	31½ ×47½ inches, for 9-column folio . . .		300 00
29×43 inches . . .	33 ×48 inches, for 6-column quarto . . .		325 00

Above prices include two pairs of points, one wrench, one sheepsfoot, pair of bearers, and one extra frisket.

As a rule we can supply second-hand Washington Hand Presses of all sizes on demand.

BRUCE TYPE FOUNDRY, 13 CHAMBERS STREET, NEW YORK.

EVERYTHING FOR THE PRINTER.

GALLEY PROOF PRESSES.

AMERICAN PROOF PRESS.

Built in the most substantial manner, thoroughly braced, with accurate bed and cylinder. The cylinder is much heavier than on the average proof press, and consequently gives a much better impression. The best proof press made.

With Iron Stand.

- No. 1, 10×31 inches inside \$30 00
- No. 2, 16×31 inches inside 42 00

Without Stand.

- No. 1A, 10×31 inches inside . . . \$22 50
- No. 2A, 16×31 inches inside . . . 30 00

Each proof press is furnished with blanket, brayer frame and stock.



American Proof Press.

CHALLENGE PROOF PRESS.

The circumference of the cylinder is the same measurement as the printing surface of the bed, the cylinder revolving once from stop to stop. The No. 1 cylinder weighs 85 lbs.; other cylinders of proportionate weights. The cylinder is covered with finest quality felt blanket, and a brayer is furnished with each press, excepting those without iron stand. Nos. 1 and 2 have shelf for paper underneath the cabinet.

Size.	Inches.	Price.
No. 0,	9 × 27, with iron stand . .	\$25 00
No. 1,	10¼ × 32, with iron stand . .	30 00
No. 2,	16½ × 35, with iron stand . .	40 00
No. 00,	9 × 27, without iron stand,	15 00
No. 01,	10¼ × 32, without iron stand,	20 00
No. 02,	16½ × 35, without iron stand,	30 00

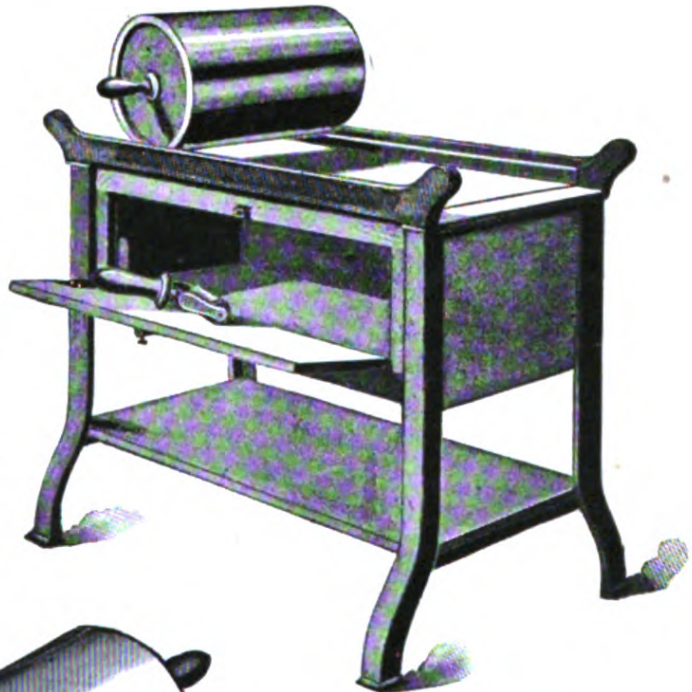

No. 1 Challenge Proof Press.

ECONOMIC PROOF PRESS.

This is the cheapest proof press made. It has no bed, but consists of a roller and braced side frame.



10×34 inches inside, complete with blanket and weight mould \$13 50

A mould is provided for casting weights which can be placed inside the cylinder to increase pressure according to character of the work.

FELT BLANKETS FOR PROOF PRESSES.

See page 564 for prices of Felt Blankets.

BRUCE TYPE FOUNDRY, 13 CHAMBERS STREET, NEW YORK.

EVERYTHING FOR THE PRINTER.

COMBINATION PAPER JOGGER.

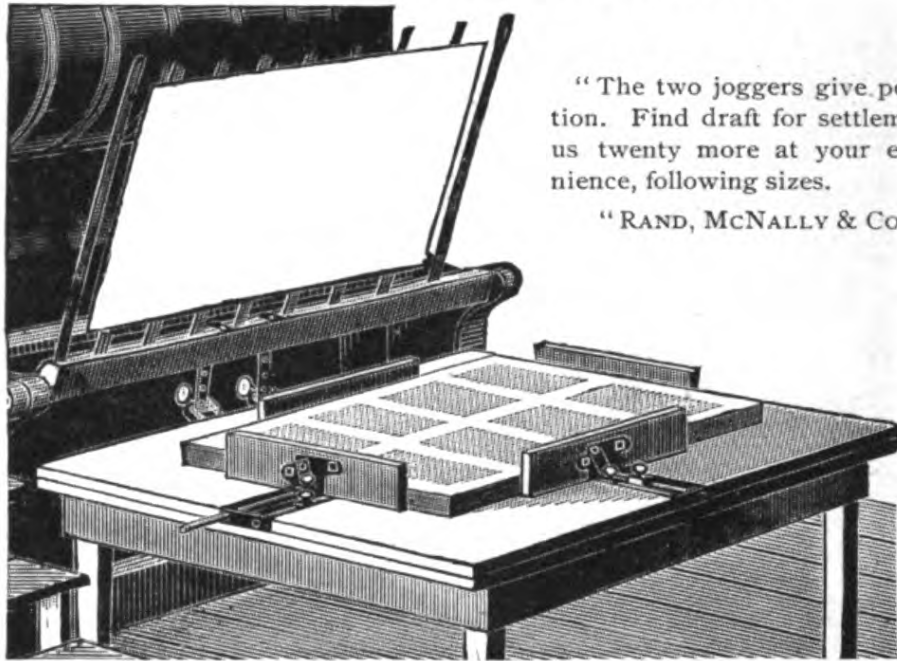

“The two joggers give perfect satisfaction. Find draft for settlement, and send us twenty more at your earliest convenience, following sizes.

“RAND, MCNALLY & Co., Chicago.”

Made with wings, to be instantly removed, if desired. No projecting rod on front side to tear clothes. This of itself is worth the price of a jogger. Patent attachable wings for small joggers, by which letter-heads, etc., can be evened up.

24×36 inches, or less	\$15 00
36×48 inches, or less	18 00
Larger than 36×48 inches	20 00

OVERHEAD POWER FIXTURES.

Consisting of countershaft, two adjustable hangers with oil cups, two cone pulleys, and driving pulley for main shaft.

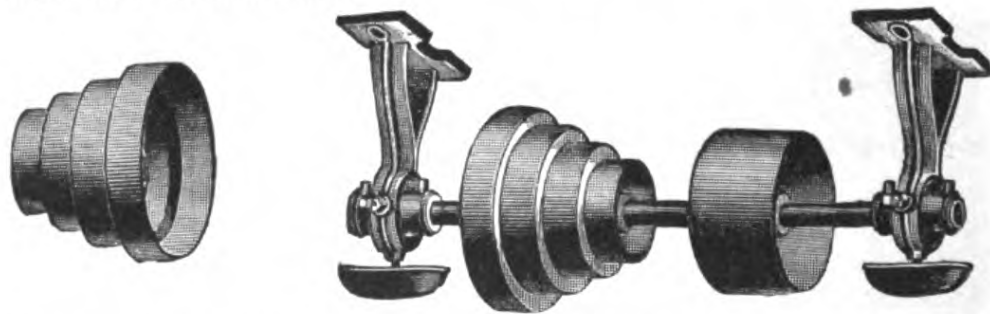

LIGHT FIXTURES FOR EIGHTH MEDIUM PRESSES AND SMALLER.

No. 1. 3 speed, 6 to 9 inches, belt 1½ inches	\$15 00
No. 2. 4 speed, 7 to 10 inches, belt 1¾ inches	18 00

HEAVY FIXTURES.

No. 3. 3 speed, Eighth Medium	\$20 00
No. 4. 4 speed, Eighth Medium	22 50
No. 5. 3 speed, Quarto Medium	22 50
No. 6. 4 speed, Quarto Medium	25 00
No. 7. 3 speed, Half Medium	27 50
No. 8. 4 speed, Half Medium	30 00

Shafting, Hangers, Pulleys and Collars furnished to order at the lowest prices.

• BRUCE TYPE FOUNDRY, 13 CHAMBERS STREET, NEW YORK.

EVERYTHING FOR THE PRINTER.

WETTER NUMBERING MACHINES.

THE BETTER WETTER.

The latest successful development in Numbering Machines, for use with or without type on printing presses. This is the only typographic numberer that prints nothing but the figures, without "No.," a period, or any other affix or suffix intended to act as plungers or to prevent the printed sheet from being smeared by the revolving figures. The pressure of the platen or cylinder on the figures operates the mechanism which changes the numbers and also an ingenious bearer, which raises automatically and holds the printed sheet off the figures while they are changing. This bearer does not print on or indent the paper.

The Better Wetter is made with that perfection in construction and materials which have made all "Wetter" Machines famous.

This is the smallest machine of its kind, being 7/8-inch wide, the length depending upon the number and thickness of figures required. *Type can be set close up to the machine on all sides.*

Four regular styles of figures made. Styles J and K kept in stock. Styles L and M furnished at short notice.

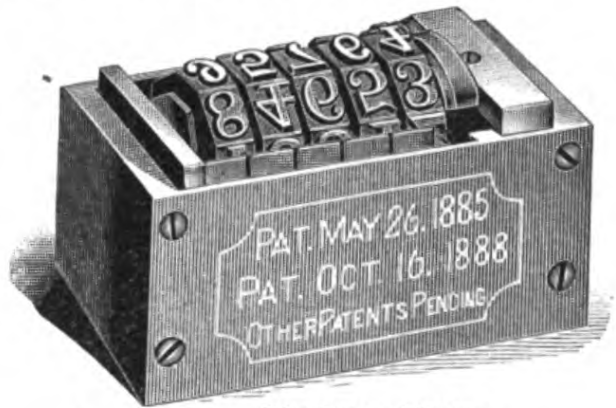

The Better Wetter.

Style J **1234567890** Style K **1234567890**

These Styles used on both the Better Wetter and No. 1 Wetter.

Style L **1234567890** Style M **1234567890**



No. 1, actual size, Style J.

No. 1 WETTER NUMBERING MACHINE.

This is the regular machine, of which thousands are in use all over the world. Permits printing and numbering at one impression. Can be used on any make of press. Numbers automatically from the unit to its full numerical capacity. It can be used with or *without* the character "No." Other characters, such as a star, parenthesis, fist, cipher, or any letter, can be used to either precede or follow the figures. Produces clean, smooth and distinct figures. Styles of figures J and K are most used, and are kept in stock, but Styles L and M can be furnished upon short notice.

The 5-wheel style J machine occupies a surface space of 3/8-inch in width by 1 1/4 inches in length.

PRICES OF No. 1 WETTER AND THE BETTER WETTER.

- Style J or K or L or M, five wheels, numbering up to 99999 \$25 00
- Style J or K or L or M, six wheels, numbering up to 999999 28 00
- Style J or K or L or M, seven wheels, numbering up to 9999999 31 00

In ordering state which machine is required, and state style of figure and number of wheels desired. Unless otherwise ordered, the 5-wheel style J Better Wetter will be sent.

SPECIAL WETTER NUMBERING MACHINES.



No. 3.

See description and prices on opposite page.

Made to Order only.

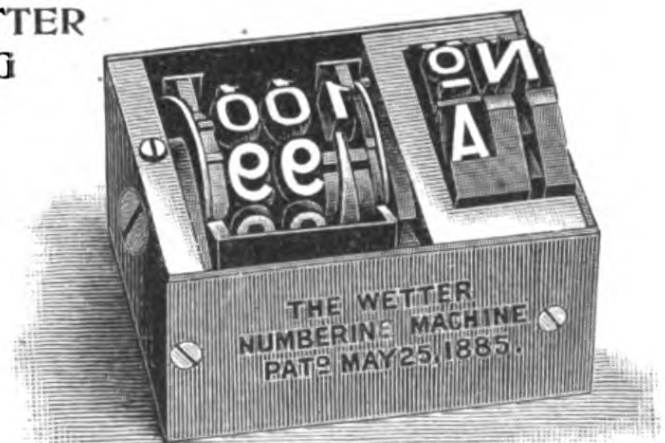

No. 4.

BRUCE TYPE FOUNDRY, 13 CHAMBERS STREET, NEW YORK.

EVERYTHING FOR THE PRINTER.

No. 3. WETTER MACHINE FOR SMALL RAILROAD WORK.

(See illustration on opposite page.)

Numbers on extreme end, as shown on diagram. Plunger is at foot of machine, and does not strike the printed sheet. Occupies only 5/8-inch space on ticket when locked in form.

1234567890

Style of Figures for No. 3 Machine.

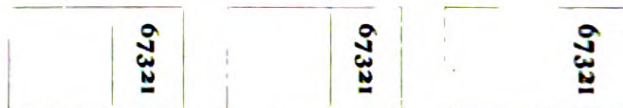

No. 3.	5-wheel (figures as above)	\$25 00
No. 3.	6-wheel	28 00
No. 3.	7-wheel	31 00

No. 4. WETTER MACHINE FOR NUMBERING CASH SALE SLIPS.

(See illustration on opposite page.)

Made to number automatically from 100 to 1, or 50 to 1. Object of numbers running backward is to avoid expense of collating sheets after printing. Can be made to number forward. After printing to 100 or 50 they commence again at 1. Plunger wheel can be made with a letter wheel to print A, B, C, D, E, F, G and H, or letter slides may be used in plunger, and any of these letters or the character "No." can be used at will by turning the wheel until the desired letter is on top.

Price, 3-wheel, with letter wheel	\$25 00
-----------------------------------	-------	---------

No. 5. WETTER DUPLEX MACHINE FOR NUMBERING DUPLEX RAILROAD TICKETS.

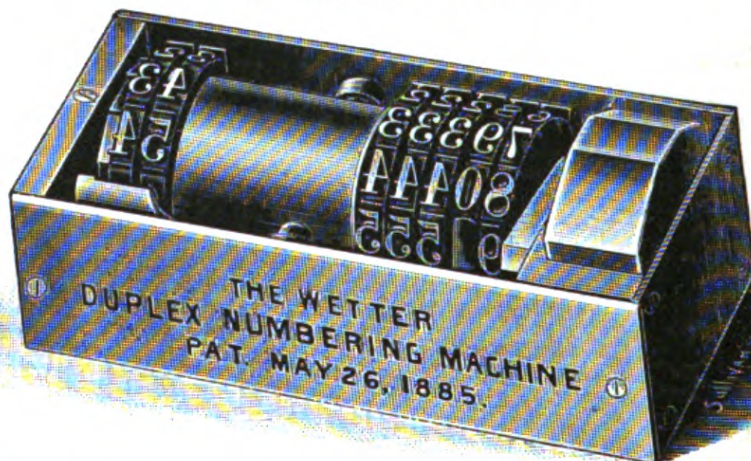

Numbers tickets on both sides and also on stub at one impression. Ticket numbers generally run from 1 to 100 or 0 to 99, and changes consecutively the book number which runs from 1 to 9999 or 1 to 99999. Can be arranged to change once at every one hundred impressions of ticket number, or can be made stationary, so that changes can be made by hand. There are three machines to a set—one for stub and one for each side of the ticket, to be used in same manner as ordinary Wetter Numberer, needing no attachment of any kind.

Set of three machines, net	\$120 00
----------------------------	-------	----------

No. 7. WETTER MACHINE FOR NUMBERING BOND COUPONS.

Numbers with or without serial attachment. 7/8-inch wide, and can be used on narrowest bond coupons. Letter wheel can be placed on end to indicate serial No. A, B, C, D, E, F, G, H, I or J; or the serial letter or character "No." can be placed close to figure, thus—A1.

Price, 5-wheel	\$25 00
Price, 6-wheel	28 00
Price, 7-wheel	31 00

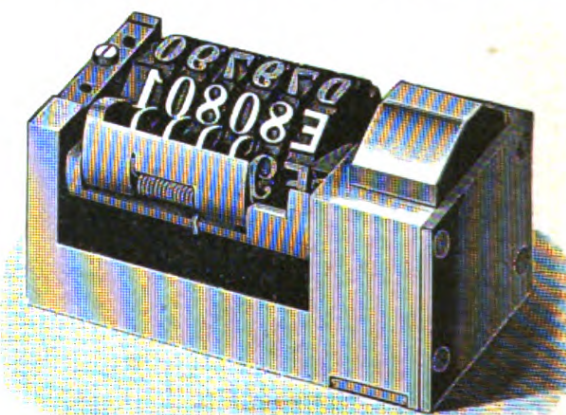

EVERYTHING FOR THE PRINTER.

BATES AUTOMATIC NUMBERING MACHINES.

These very superior machines operate consecutively, duplicate and repeat, and the changes are made instantaneously by simply moving the pointer on the dial. The figures are cut in steel and print perfectly. The movement of the figures is entirely automatic from 1 to the full numerical capacity of the machine. The figures receive ink automatically from a thick felt pad. The mechanism, material and finish are unsurpassed. Weight about 16 ounces. These machines are all furnished with special retarding device, which absolutely prevents the figures from ever getting out of alignment. Another great feature is that the ciphers are depressible, which makes the wearing even on all parts of these machines. The mechanism of the Bates Automatic Numbering Machine is internal, and it is entirely enclosed, so that it is not liable to get out of order or get clogged by dust. The ink-pad box is so arranged that the ink pad can be easily re-inked without soiling the fingers. The gauge plate is slotted, corresponding with the number of wheels of the machine, so that the exact location of the figures can be absolutely determined.

In lieu of Duplicating movement machines can be supplied with any one of the following movements at same prices: Tripling, Quadruplicating, Quintuplicating, Sextuplicating, but are not carried in stock, being made to order only.



Bates Machine, one-half actual size.

A 12345 E 12345
 G 12345 F 12345

Styles E and G are kept in stock and A and F are furnished to order at short notice.

4 wheels, numbering to 9,999	\$12 00
5 wheels, numbering to 99,999	14 00
6 wheels, numbering to 999,999	16 00
7 wheels, numbering to 9,999,999	18 00

Prices include ink and pad.

PARAGON NUMBERING MACHINE.

A machine of a cheaper grade, but accomplishing the same work as the Bates, the chief difference in method of construction being in the dial changer. In this machine the changes are made by inserting a pin in the holes opposite the indicators.

4 wheels, numbering to 9,999	\$ 8 00
5 wheels, numbering to 99,999	9 00
6 wheels, numbering to 999,999	10 00
7 wheels, numbering to 9,999,999	12 00

Each machine in wood box, with bottle of ink.

In ordering, state style of figures required. Paragon Machines with Gothic figures can be supplied at same prices.

R 1234567890
 S 1234567890
 T 1234567890
 W 1234567890



INK FOR NUMBERING MACHINES.

Ink—No. 0, ½ oz.	20 cents per bottle.	Ink—No. 3, 4 oz.	40 cents per bottle.
No. 2, 2 oz.	25 cents per bottle.	Extra felts for ink pads	10 cents each.

BRUCE TYPE FOUNDRY, 13 CHAMBERS STREET, NEW YORK.

EVERYTHING FOR THE PRINTER.

THE AMERICAN JOB PRESS
COUNTER.

For Platen Presses.

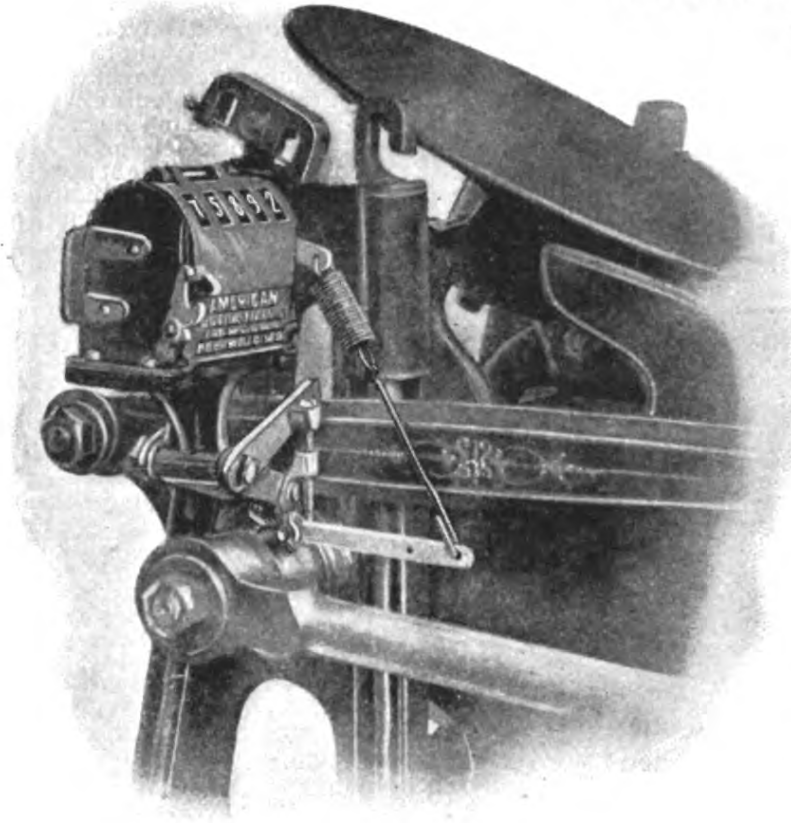

The above cut shows Counter attached to an 8 x 12
Chandler & Price Gordon.

We place this counter on the market after testing its merits thoroughly and believing that the printer will appreciate a reliable counter with which he can keep an accurate record of the number of impressions on his job presses. The counter registers *only when the impression is on.*

There is absolutely no strain whatever on the counter or attachment, the movement being positive and easy, and when once it is set needs no further attention. It can be attached to almost any Gordon press. Give size and make of press when ordering.

Any number wheel can be set forward or backward without disturbing the others.

There are no screws used in the entire construction, and the parts are so put together that they cannot get out of order or become disarranged while in use.

The pawls or dogs are so made that there are no corners to wear off and make the counting uncertain.

Price \$12 00

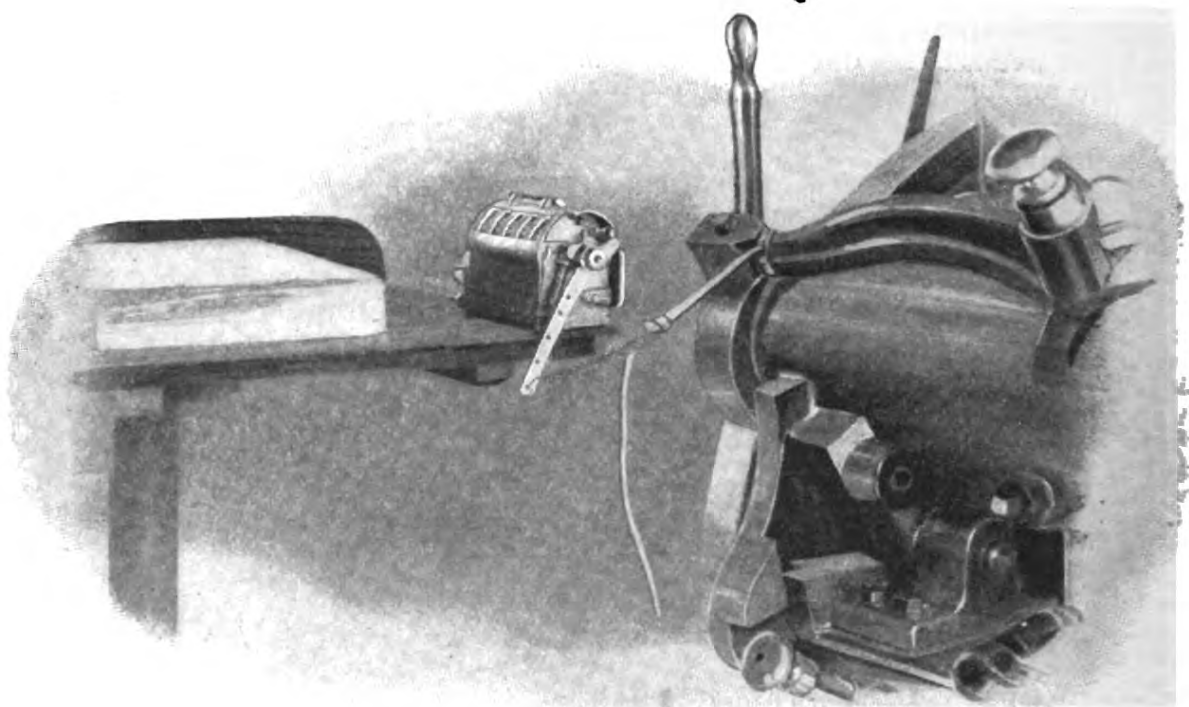

The above cut shows Counter fastened on left feed table of Gally Universal Press.

Price \$10 00

BRUCE TYPE FOUNDRY, 13 CHAMBERS STREET, NEW YORK.

EVERYTHING FOR THE PRINTER.

AMERICAN COUNTING MACHINE.

Has no superior for strength, accuracy, reliability. Can be set to zero, or any number, with the fingers with the greatest ease. There are no springs inside this counter, and all movements of the figure-dials are so positive that it is impossible for them to miss registering. The case may be screwed to the wall or on a table, and the lever can be set to any position, and will work from front or back. The figures are cast solid, nickel-plated, and are very legible.



Price \$10 00

See illustration of this Counter attached to a C. & P. Gordon and a Universal Press on opposite page.

DURANT COUNTER.



This counter gives perfect satisfaction. It is as reliable as it is strong, durable, and attractive.



No. 2, with Alarm Gong.

- No. 1, 4-dial, counts 10,000 . . . \$ 8 00
- No. 2, 5-dial, counts 100,000 . . . 10 00
- No. 3, 6-dial, counts 1,000,000 . . . 12 00
- No. 2A, 5-dial, with 4-inch gong, to give alarm at each 100 15 00

DOUBLE DIAL ALARM COUNTER.

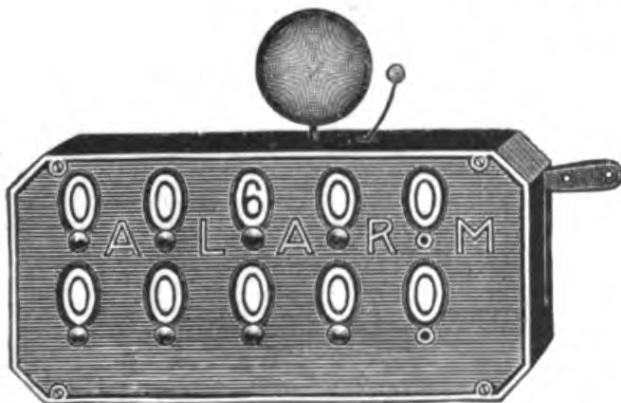

This counter is so constructed that the lower dials show the number run like the usual counter. The upper dials are the alarm device, and can be set (instantly without taking from the case, by thumb-screw or key) to any desired number you wish to print, and when that number is printed the bell will ring. To illustrate: Set the alarm on 600, if that is the number you wish to run, with lower dials on ciphers. First revolution of the machine the lower dials will show 1, and the upper dials 599 or one less, and so on until 600 is run, when the upper dials will stand at (000) ciphers and the bell will ring. Any time you look at the counter

it will show how many yet to run. Perfectly simple in construction. No more springs are used than in an ordinary counter, and all are made of best piano wire. This counter has an iron case, and very legible figures.

No. 1. Double Dial Alarm, 5x8, 1/2-inch figures, registering 100,000 \$15 00

BRUCE TYPE FOUNDRY, 13 CHAMBERS STREET, NEW YORK.

EVERYTHING FOR THE PRINTER.

PEERLESS GEM PAPER CUTTERS.

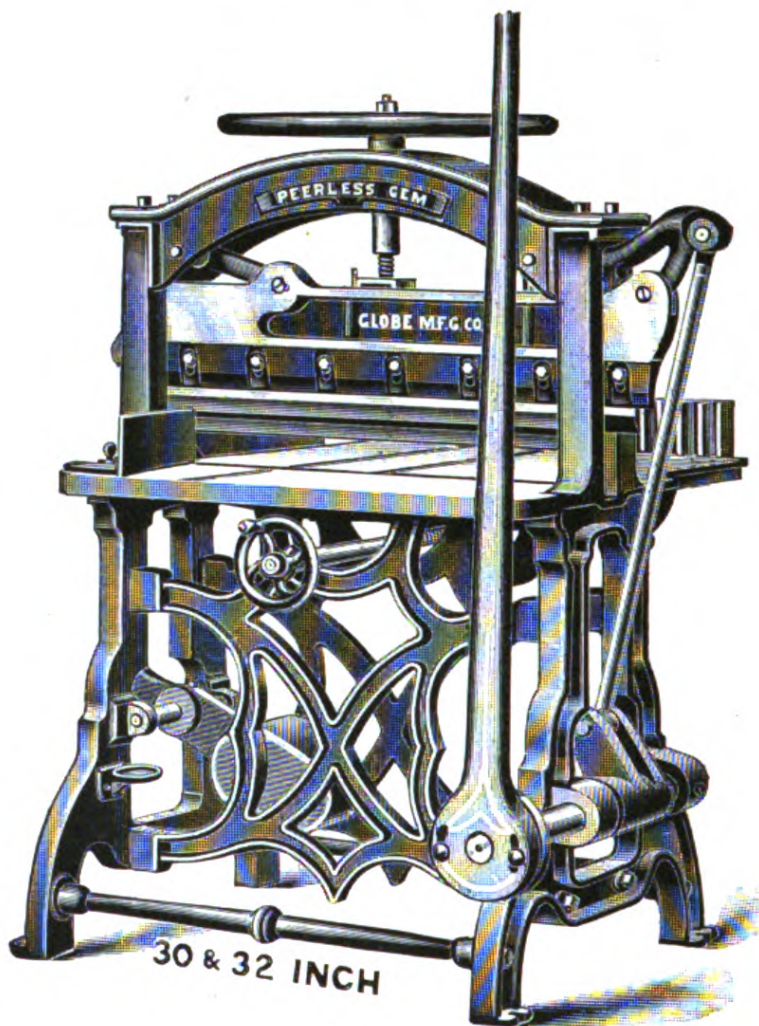

DETAILS OF CONSTRUCTION.

Weight, Unboxed.	Thickness of Knife Bar.	Thickness of Knife.	Depth of Knife.	Diameter Lever Shaft.	Diameter Steel Lever Connection Shaft.
30-inch . 1340 lbs.	1 ¼ in.	½ in.	5 in.	2 in.	1 ½ in.
32-inch . 1425 lbs.	1 ¼ in.	½ in.	5 in.	2 in.	1 ½ in.

Superior in every detail and in the leverage, cutting with greater ease to operator, and returning from cut with the least possible exertion, owing to their perfect balance. The frame is stronger, heavier and better braced; the knife thicker and deeper, insuring a truer cut and longer life; the lever is adjustable; the balance weight is now hung inside the frame, thus saving floor room. There are split back gauges, side gauges, and a front enameled measuring gauge. Unexcelled in construction, materials used, and finish.

23-inch, cuts 23 ¼ inches	\$100 00
25-inch, cuts 25 ¼ inches	125 00
30-inch, cuts 30 ¼ inches	175 00
32-inch, cuts 32 ¼ inches	200 00

Compare details of construction given above with those on other cutters.

BRUCE TYPE FOUNDRY, 13 CHAMBERS STREET, NEW YORK.

EVERYTHING FOR THE PRINTER.

25-INCH PEERLESS GEM CUTTER.

Excels all other cutters of its size in weight, ease of cut, strength, durability and finish. It is built on the same design as the Peerless Gem in all points, except that the lever is fixed on the shaft instead of being adjustable. The weight is 825 pounds, unboxed; has $4\frac{1}{2} \times \frac{3}{8}$ -inch knife; $1\frac{3}{4}$ -inch knife bar. The best money's worth ever offered in a 25-inch paper cutter.

The leverage both while cutting and returning is perfect, reducing the exertion of cutting to a minimum.

The balance weight is hung inside the frame to save floor space.



Style of 25-inch Peerless Gem Cutter.

25-inch, cuts $25\frac{1}{4}$ inches \$125 00

23-INCH PEERLESS GEM CUTTER.

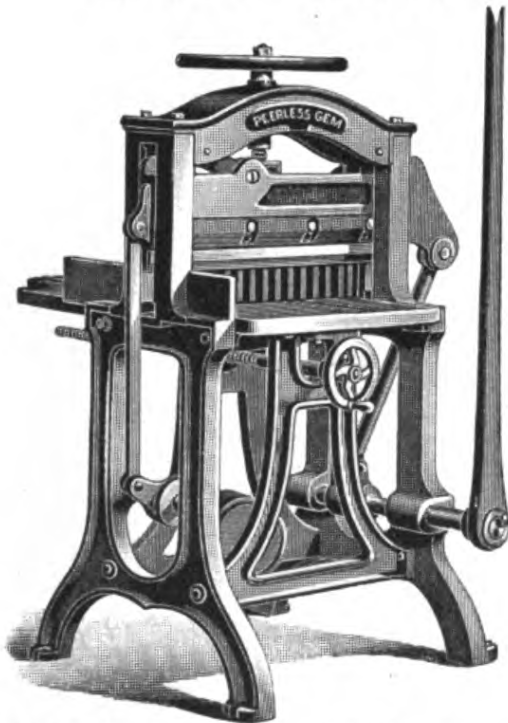

Style of 23-inch Peerless Gem Cutter.

No other cutter of this size, or about this size, equals the new 23-inch cutter. It weighs 725 pounds, unboxed; has $4\frac{1}{2} \times \frac{3}{8}$ -inch knife, and $1\frac{3}{4}$ -inch knife bar. Built on the Peerless-Gem principle, it has leverage of maximum power and easy return, and all the features of the 25-inch Peerless Gem Cutter. It is not possible to build a better cutter for the money asked.

The balance weight is hung inside the frame, thus saving floor space and removing an annoying obstruction.

23-inch, cuts $23\frac{1}{4}$ inches \$100 00

BRUCE TYPE FOUNDRY, 13 CHAMBERS STREET, NEW YORK.

CHANDLER & PRICE PAPER CUTTER.

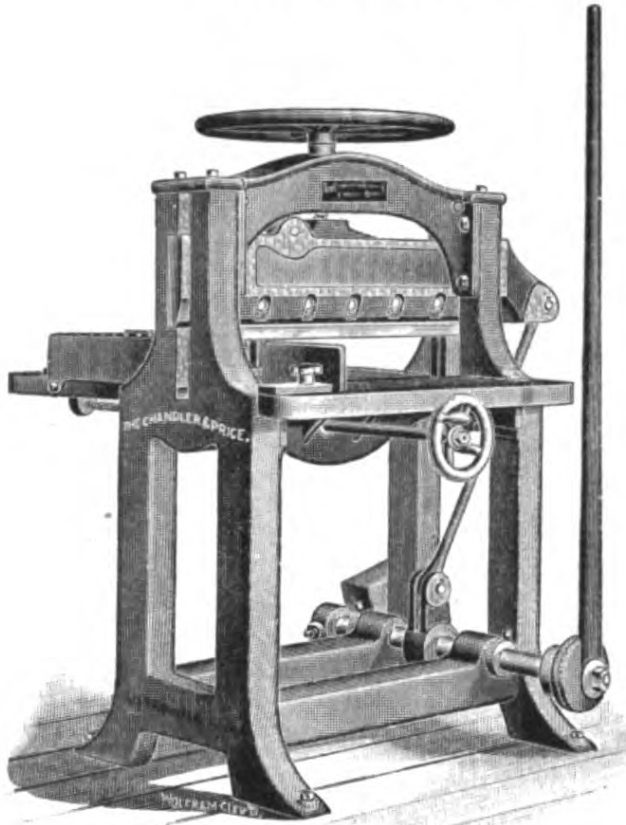

It is built from new designs by scientific methods. It has ample metal, properly distributed to withstand strains. The back gauge and clamp interlock, clamping as narrow as one-half inch. The fingers of the clamp have a broad surface, to avoid creasing the stock. All gauges are accurately squared with the knife. The back gauge extends to within one inch of the side gauge, and is divided and adjustable for book trimming or squaring small work. All parts are strictly interchangeable, and accurately fitting replacements may be ordered by number.

Made by one of the most reliable builders of printing machinery in the world.

23-inch	\$100 00
26-inch	130 00
30-inch	175 00

CHALLENGE LEVER PAPER CUTTER.

Has set screws and gibs in the frames for taking up wear of knife-bar.

The 25-inch cutter is provided with both front and back stationary side gauges, which are cast on the side frame, and are accurately squared to knife and back gauge. The 30-inch and 32-inch cutters have, in addition to these, an extra side gauge in front, adjustable to either side; also a split back gauge, useful in trimming pamphlets. They are provided with the interlocking back gauge and clamp, for cutting narrow widths, without extra cost.

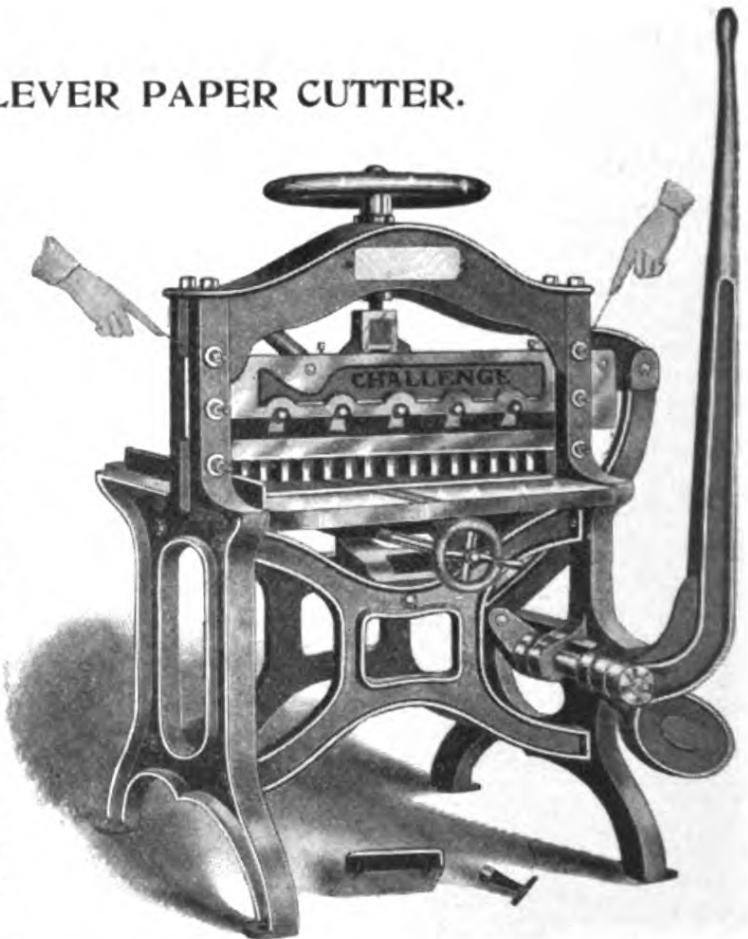

25-inch	\$135 00
30-inch	200 00
32-inch	225 00

BRUCE TYPE FOUNDRY, 13 CHAMBERS STREET, NEW YORK.

EVERYTHING FOR THE PRINTER.

RELIANCE LEVER PAPER CUTTER.

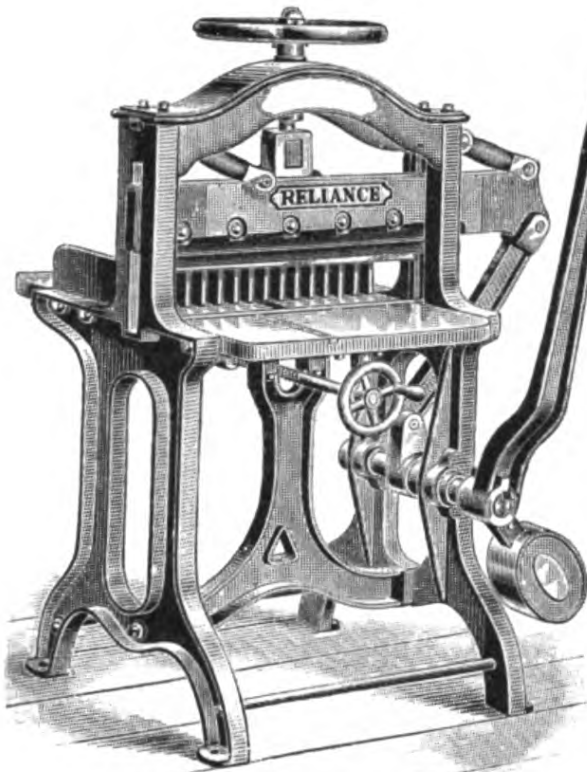

23-inch	\$90 00
25-inch	110 00
28-inch	135 00

ADVANCE LEVER PAPER CUTTER.

Its special feature is the arrangement for taking up wear in the slideway in which knife bar moves by means of steel gibs controlled by set screws.

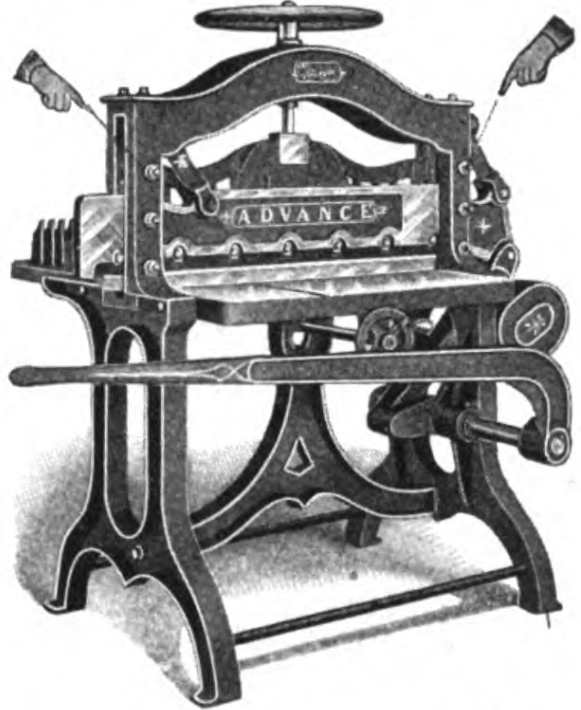

22½-inch	\$ 90 00
25-inch	110 00
30-inch	165 00
33-inch	200 00

CHALLENGE PONY LEVER PAPER CUTTER.

Used in conjunction with larger cutters, small cutters such as these and the cutters shown on page 524 often double the cutting capacity of an office at a small additional plant expense.

The especial advantage of the 19-inch cutter is that it cuts the usual sizes of flat papers—cap, demy, folio, double cap, medium, and royal.

Prices include interlocking back gauge and clamp, permitting stock to be gauged within one-half inch of knife.

16-inch	\$50 00
19-inch	65 00

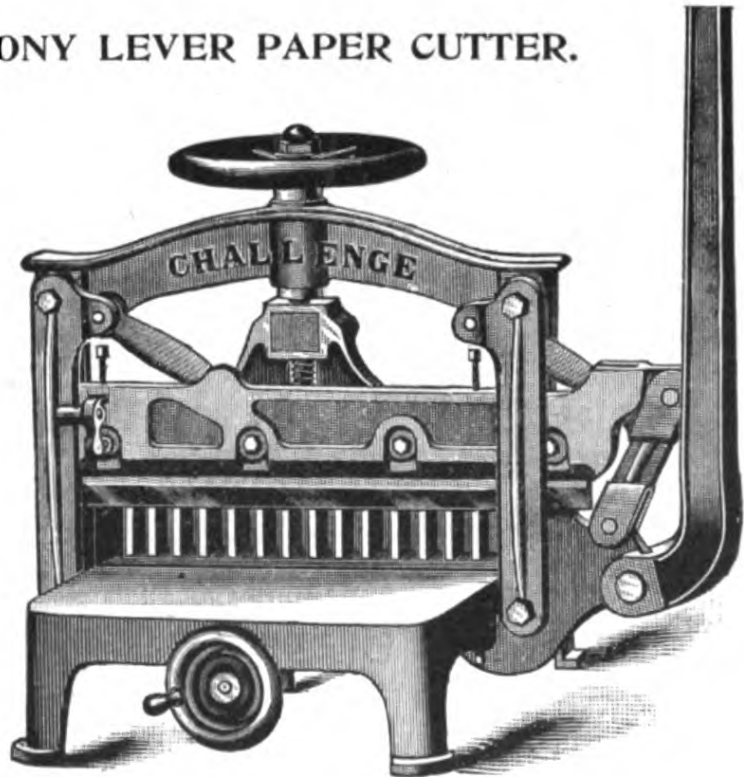

BRUCE TYPE FOUNDRY, 13 CHAMBERS STREET, NEW YORK.

UTILITY PAPER CUTTER.

A thoroughly well-built cutter, without a superior of its size. Has side and back gauges, and a patent reversible clamp which cuts very narrow strips without marking the paper.

	Without Stand.	With Iron Stand.
Cuts and squares 16 inches . . .	\$50 00	\$57 00
Cuts and squares 18 inches . . .	60 00	67 00

EXTRA KNIVES.

16-inch	\$4 50
18-inch	6 00

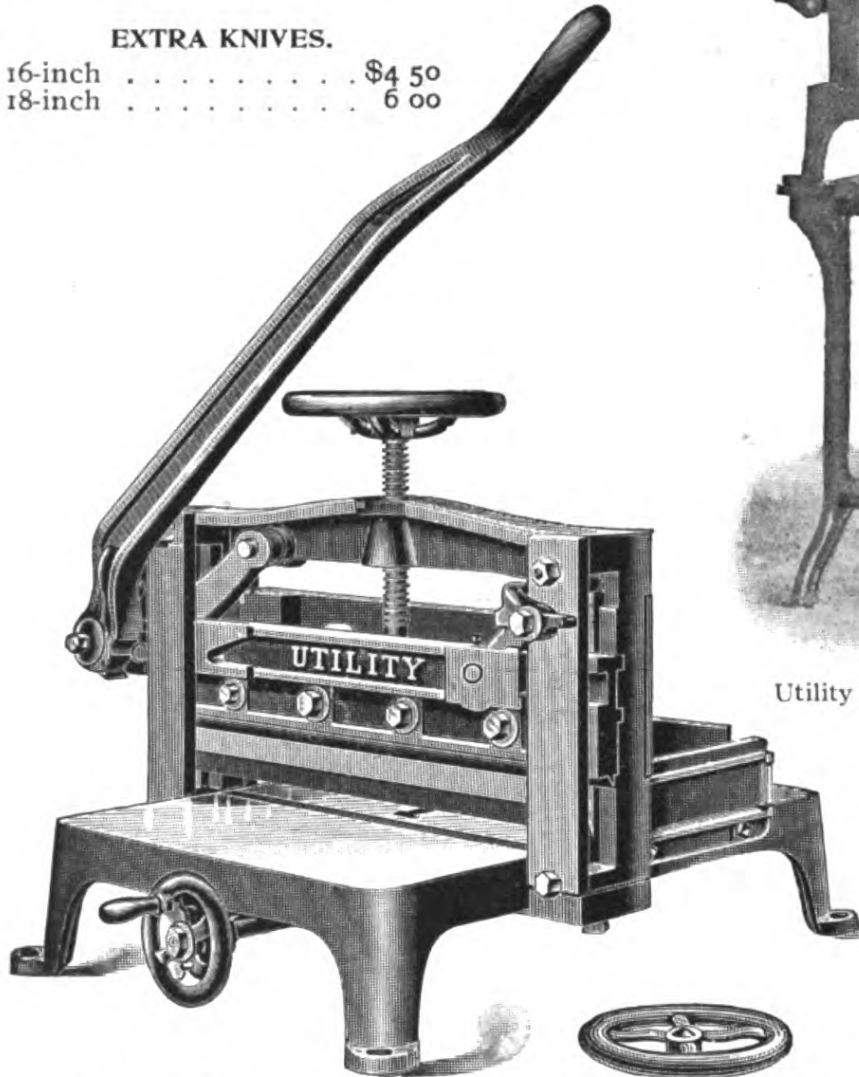

Utility Paper Cutter with Iron Stand.

WITH IRON STAND.

Iron stands are made for each size, and are recommended where bench room should be saved.

CLIPPER PAPER CUTTER.

Designed for cutting small work, such as labels, circulars, etc. Has a patented reversible clamp, which cuts very narrow strips and leaves no marks on the paper. The lever is pulled forward to cut. Quality of construction is A1.

Cuts and squares 12 inches . . . \$40 00

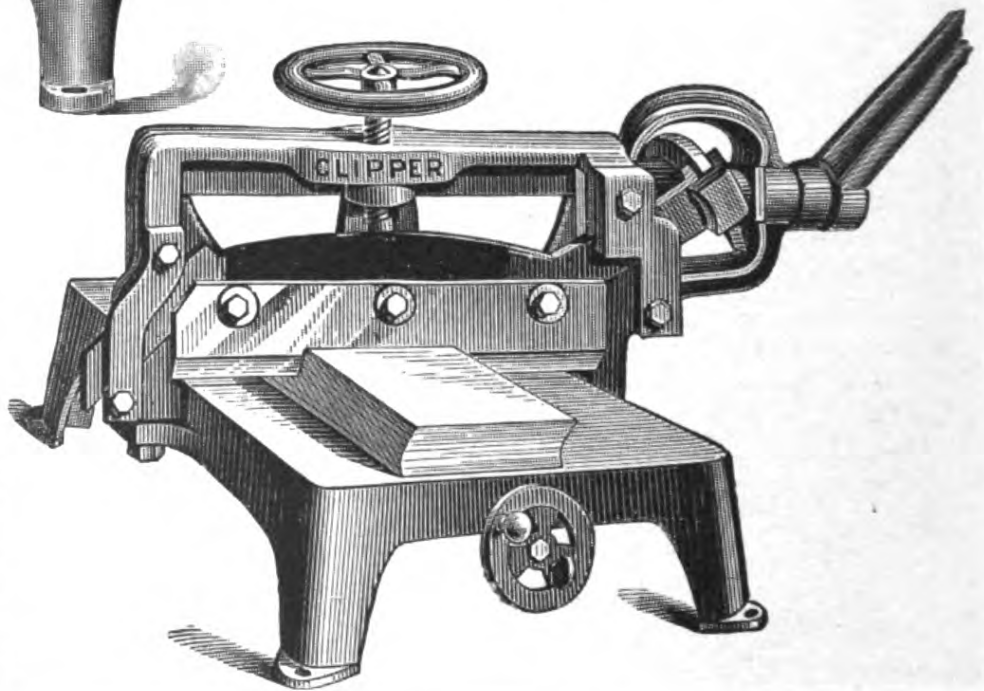

EVERYTHING FOR THE PRINTER.

ADVANCE POWER CUTTER.

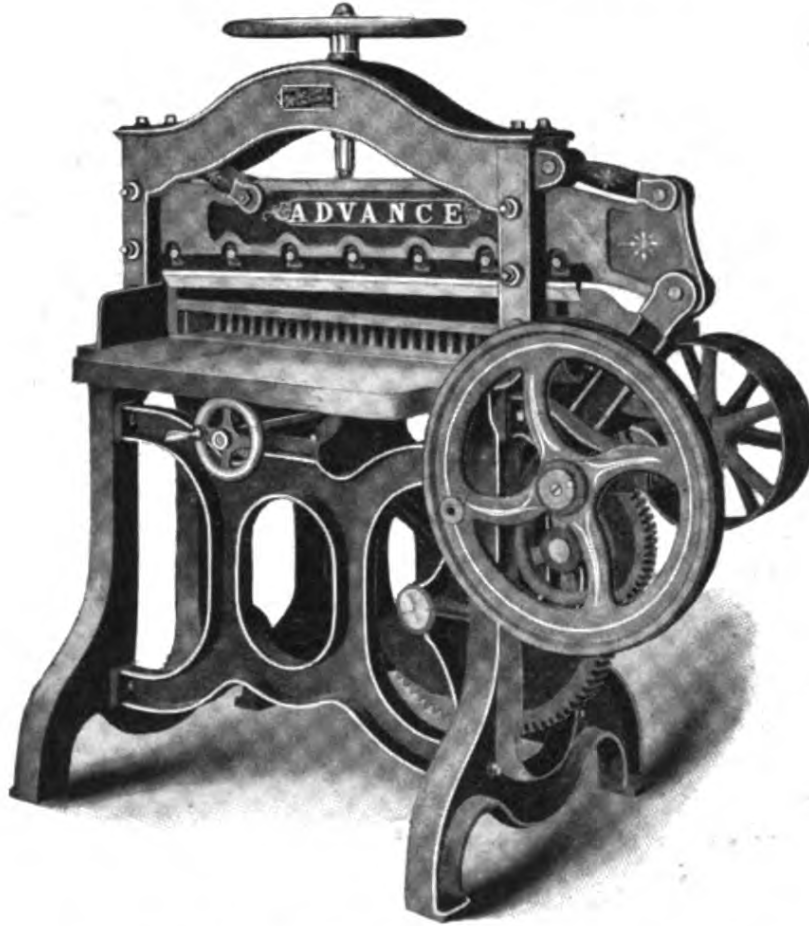

This is the lowest-priced Power Paper Cutter on the market, and can be recommended to buyers with whom low price is a prime consideration.

The Advance Power Cutter is fitted for hand or steam, is solidly built, the frame is firmly stayed by two substantial cross-braces, upon which is bolted the arch that supports the center of the bed, making it perfectly rigid and firm under pressure of clamp or knife.

It is fitted with the interlocking back gauge and clamp, by which paper may be cut to within half an inch of the knife.

It has brass figured rules in bed, back and front.

The throw-off is automatic and stops the knife instantly. It may be thrown off at any point, thus obviating possible waste of paper through error.

The knife has a dip-cut, which will be duly appreciated by all requiring a power paper cutter.

The slideways in which the knife bar moves is faced with steel gibs secured and adjusted by means of three set-screws on each side, so that any wear in the slideways may be taken up quite easily.

This is a very convenient style of cutter, as it will be found to be an effective and easily operated hand-power cutter at times when other power is not available.

30-inch, squares 30 inches	\$300 00
33-inch, squares 33 inches	350 00

BRUCE TYPE FOUNDRY, 13 CHAMBERS STREET, NEW YORK.

EVERYTHING FOR THE PRINTER.

PEERLESS POWER PAPER CUTTER.

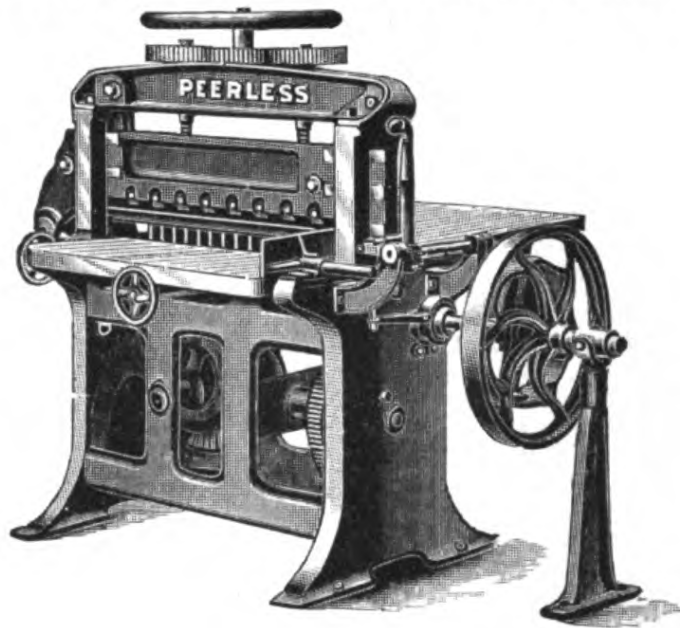

A powerful, compact, well-built cutter. The clamp is operated by two worm screws, which give it great firmness. Has interlocking back gauges and clamp, side gauges and measuring gauge. All movements are positive; all adjustments easy and rapid.

Cuts 36 inches square	\$650 00
Cuts 40 inches square	800 00

CHALLENGE POWER PAPER CUTTER.

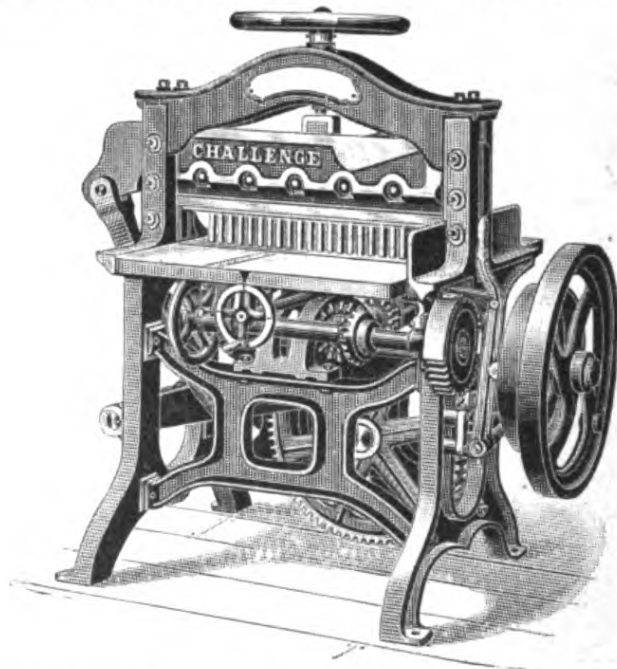

This cutter is provided with side gauges, back and front; an extra reversible side gauge for front table; split back gauge; interlocking back gauge and clamp, for cutting narrow widths; brass figured rules in bed, back and front. The slideways on which the knife bar moves are faced with gibs controlled by set screws, so that all wear in the slideways may be taken up.

30-inch, squares 30 inches	\$400 00
32-inch, squares 32 inches	450 00
36-inch, squares 36 inches	650 00
40-inch, squares 40 inches	750 00

BRUCE TYPE FOUNDRY, 13 CHAMBERS STREET, NEW YORK.

EVERYTHING FOR THE PRINTER.

BOSTON CARD CUTTERS.

With Accurate Gauges.

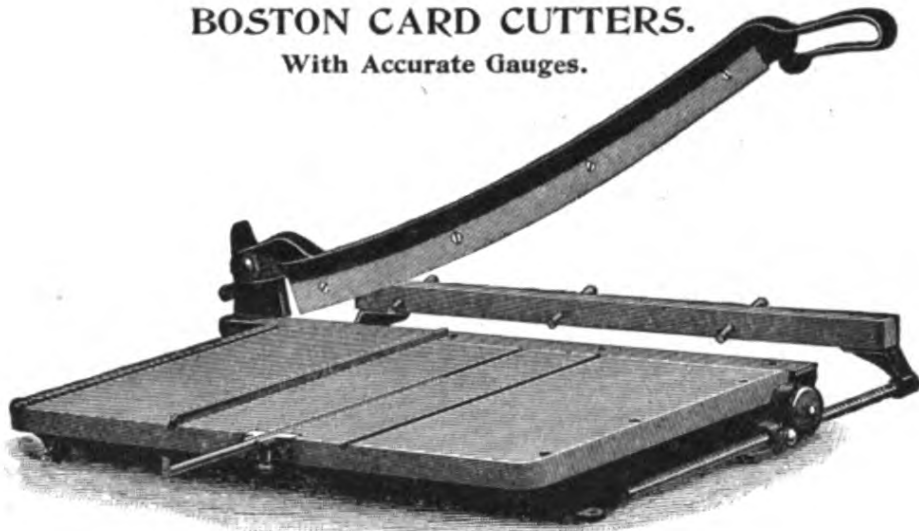

No. 24. With 24½-inch blade.

These cutters have iron frames and polished hard wood tables. The Nos. 12 and 24 sizes have accurate front, side and back gauges. The front gauge is operated by racks and pinions which hold the gauge securely at each end, and move it exactly parallel with the knife. No clamp is required, as the knives have a drawing cut, which keeps the sheet straight.

The No. 12 size will cut any length of sheet in two or more cuts, as the standard that holds the knife bar is on its inner side in line with the cutting edge, as shown in the cut.

The No. 8 size has a reversible gauge, which may be used either at front or back.

No. 8, with 8½-inch blade	\$ 8 50
No. 12, with 12½-inch blade	12 00
No. 24, with 24½-inch blade	20 00

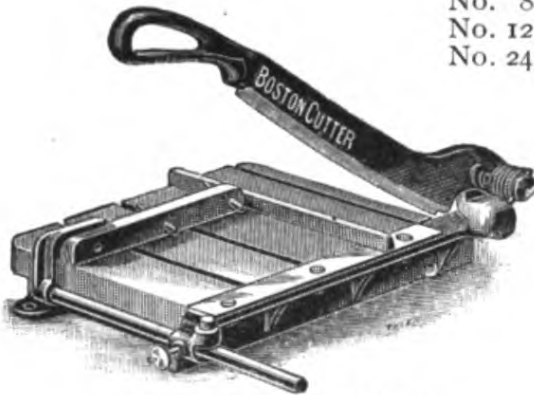

No. 8. With 8½-inch blade.

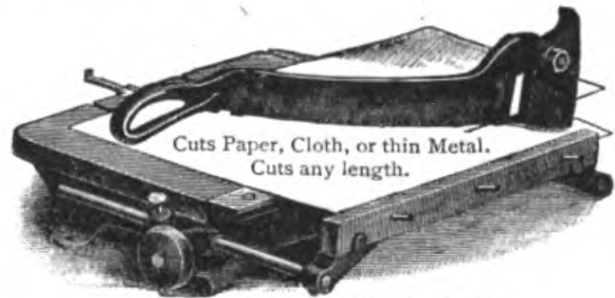

No. 12. With 12½-inch blade.

SUCCESS CARD CUTTER.

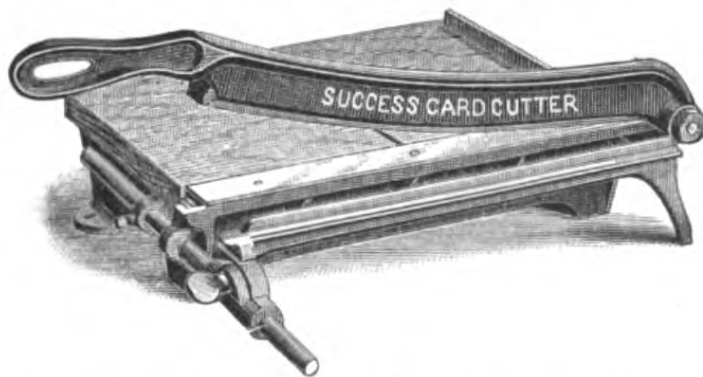

A well-made, reliable cutter, with movable side and front gauges. 12-inch knife \$10 00

BRUCE TYPE FOUNDRY, 13 CHAMBERS STREET, NEW YORK.

EVERYTHING FOR THE PRINTER.

THE CHALLENGE BOOK STABBER.

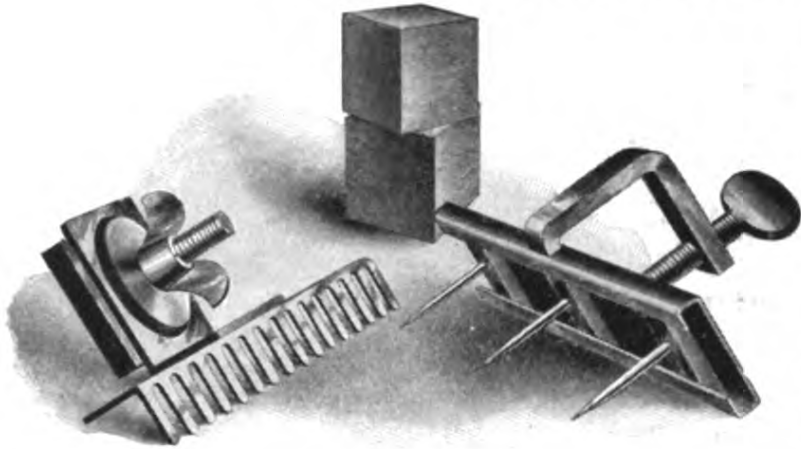

For use on clamp of paper cutter. Needles can be set any distance apart within a space of seven inches, and stab one sheet to three-quarter-inch thick. Invaluable in any printing office.

It is especially handy in binding pamphlets of all descriptions, stenographers' note books, memo. tabs, receipts, order blanks, etc.—in fact, all kinds of check binding is easily, neatly and quickly done.

By reference to the illustration below it will be seen that the stabber is easily attached to the clamp of the cutter. The comb-like piece in the illustration is the stripper, and is attached to the bed of the cutter, acting as a stripper and a back gauge for the work.

Cheapest and most efficient device for the purpose made.

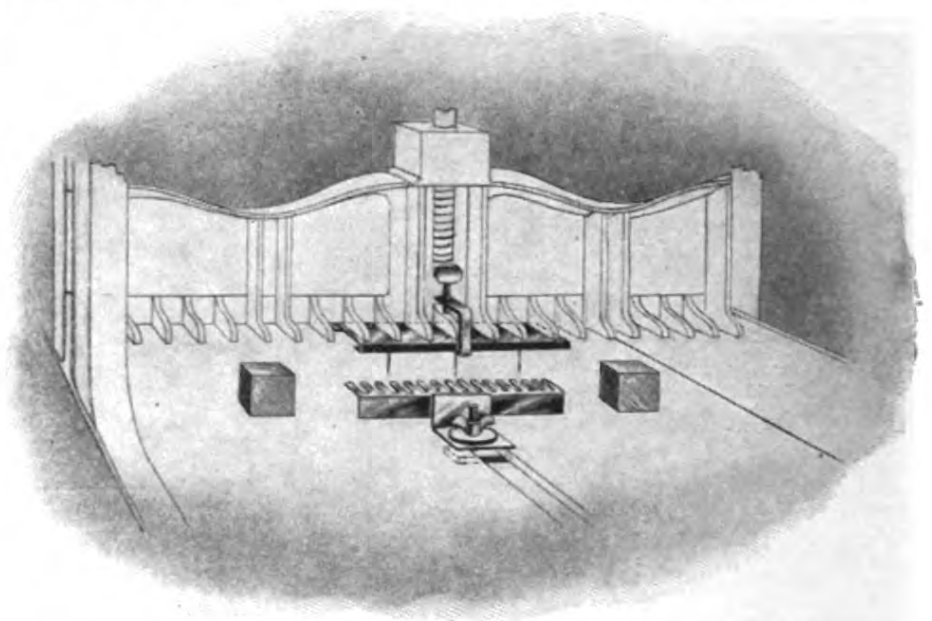

Challenge Book Stabber Adjusted on a Paper Cutter Ready for Use.

Price, complete \$4 00

HAND STABBING MACHINE.

For stabbing pamphlets, receipt books, etc., by hand or foot power. Built of iron, and made to fasten to a bench or table. The position of the needles can be easily and quickly changed, as they move laterally in a slot, and are held by set screws.



For hand power \$25 00
 For foot power 50 00
 Needles, per dozen 3 00

BRUCE TYPE FOUNDRY, 13 CHAMBERS STREET, NEW YORK.

EVERYTHING FOR THE PRINTER.

MONITOR-AUTOMATIC WIRE STITCHERS.

No. 00 MONITOR WIRE STITCHING MACHINE.

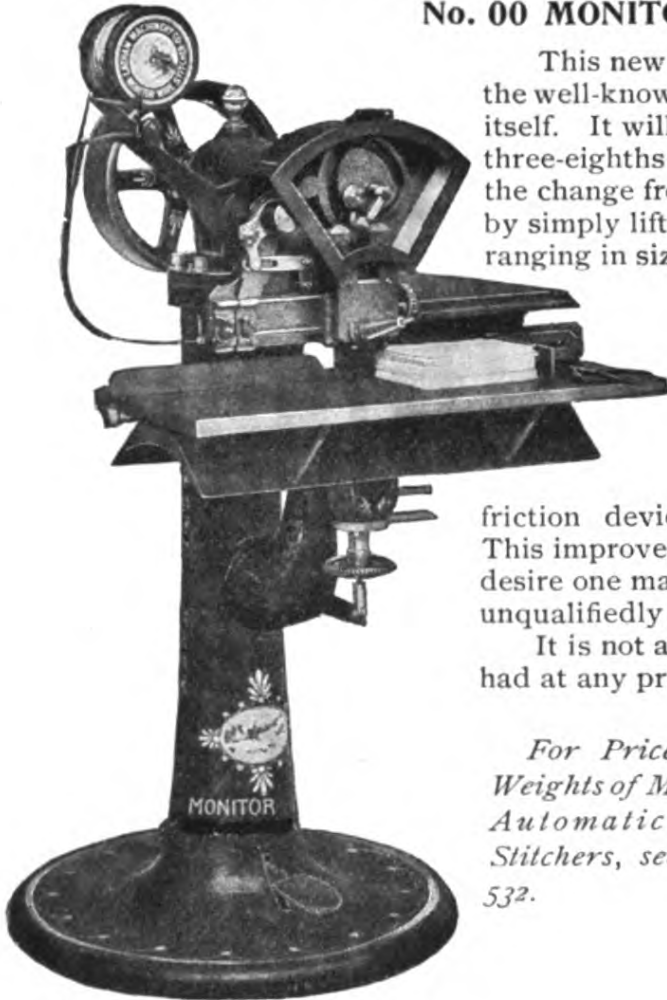

No. 00 Monitor Wire Stitcher.

The No. 00 Monitor will handle the largest range of work of any wire stitcher in the world.

This new machine combines all the good points of the well-known No. 0 with valuable features peculiar to itself. It will handle work from one sheet to one and three-eighths inches in thickness, either flat or saddle, the change from one to the other being made instantly by simply lifting off or replacing the flat table. Wire ranging in size from No. 25 round to No. 19 to 21 1/2 flat can be used with equal facility, an ingenious improvement in the feeding mechanism insuring the smallest wire being fed without bending or kinking. The spool tension is so arranged that just enough wire for one staple is delivered at a time, doing away with friction devices which require constant adjusting. This improved Monitor will be welcomed by those who desire one machine to handle a variety of work, as it is unqualifiedly guaranteed to do all that is claimed for it.

It is not a low-priced machine, but the best to be had at any price.

For Prices and Weights of Monitor Automatic Wire Stitchers, see page 532.

No. 0 TWENTIETH CENTURY MONITOR WIRE STITCHER.

Our No. 0 is designed for flat or side stitching only, and has a range of work from 1/4 inch to full 1 3/8 inches. It has all the same mechanism as the No. 00, with the exception that it does not have the saddle table for doing saddle stitching. It is provided with automatic clamp, if desired, for soft, spongy paper, which compresses the book firmly while being stitched, thus avoiding the breaking or tearing of the top and bottom sheets, or cover.

No change of parts for various thicknesses of work.

Guaranteed to stitch up to its fullest capacity.

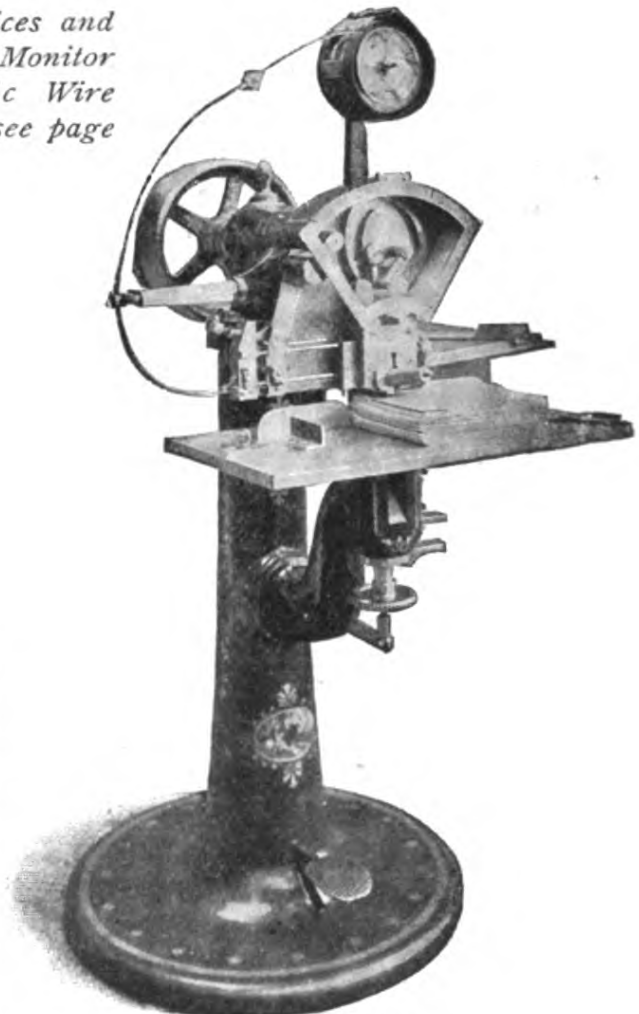

No. 0 Monitor Wire Stitcher.

Will stitch from 1/4 inch to 1 3/8 inches. Designed for flat work only.

BRUCE TYPE FOUNDRY, 13 CHAMBERS STREET, NEW YORK.

EVERYTHING FOR THE PRINTER.

MONITOR AUTOMATIC WIRE STITCHERS.

(Continued.)

TWENTIETH-CENTURY MONITOR WIRE STITCHER.

The Twentieth-Century Monitor Stitchers are undoubtedly the finest stitchers ever produced. They will stitch one thickness of tissue paper with No. 30 wire up to their fullest capacity with round or flat wire without change of parts. Our latest improved spool tension works automatically, and at each stroke of the feed lever it releases sufficient wire only for the next staple. Users will appreciate this improvement. It has an indicator numbered 1, 2, 3, 4, 5, 6, which is adjusted instantly for various lengths of staples. The cutter is now provided with a separate cutting blade, which has two cutting surfaces, and which can be replaced at a cost of a few cents (heretofore new cutters cost \$1.25 each). This cutter can be taken out of machine or replaced by hand without the use of tools. The new straight and roll-feeding attachment feeds the wire into the machine perfectly straight, and produces a perfect square staple, which is absolutely necessary to accomplish thick, heavy stitching. Also provided with wire straightener, automatic gauge, flat and saddle table, back and side gauges, etc.

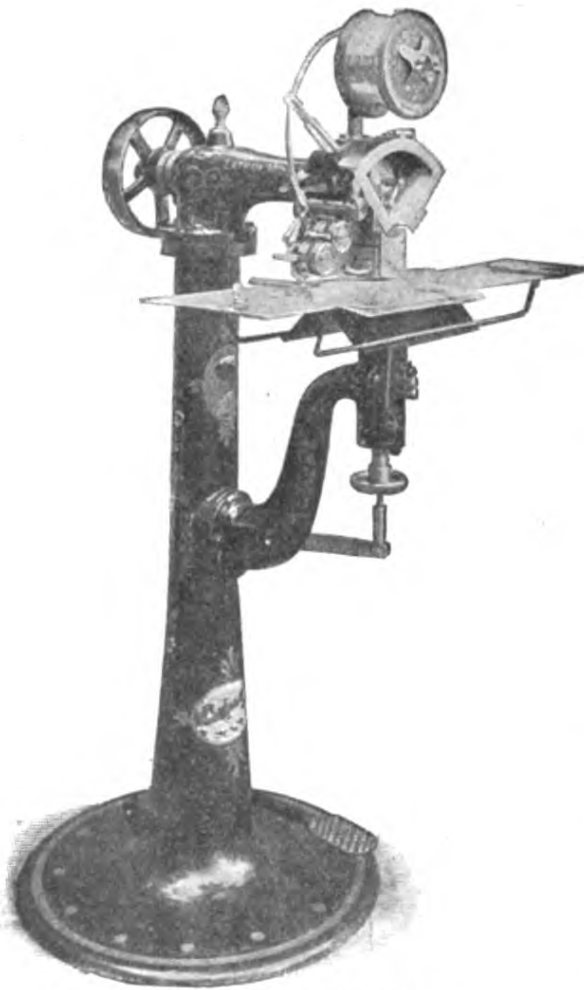

No. 2½ Monitor Wire Stitcher.
Capacity, ¼ inch.

No. 1¾ and No. 2 are of the same design.

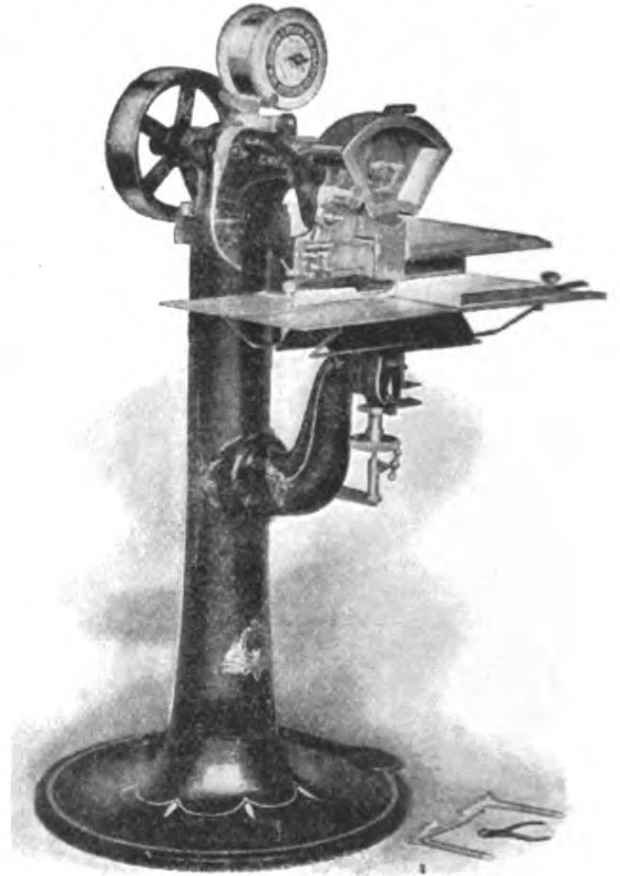

No. 1 Twentieth Century Monitor Wire Stitcher.
Capacity, ⅜ inch.

No. 1½ is of the same design.

No. 2½ MONITOR
WIRE STITCHER.

The No. 2½ Monitor is especially adapted for large pamphlet and calendar work. It has a drop of 16 inches, or a reach from clincher block to stand of 11 inches. It is constructed with a roll-feeding device which feeds the wire between two steel rollers, producing an evenness of feed and every staple of even length. Also equipped with improved spool tension, automatic gauge, flat and saddle table, gauges, etc.

This size machine can be run at a great speed, and is a big money maker.

For Prices and Weights of Monitor Automatic Wire Stitchers, see page 532.

BRUCE TYPE FOUNDRY, 13 CHAMBERS STREET, NEW YORK.

EVERYTHING FOR THE PRINTER.

MONITOR AUTOMATIC WIRE STITCHERS.

(Continued.)

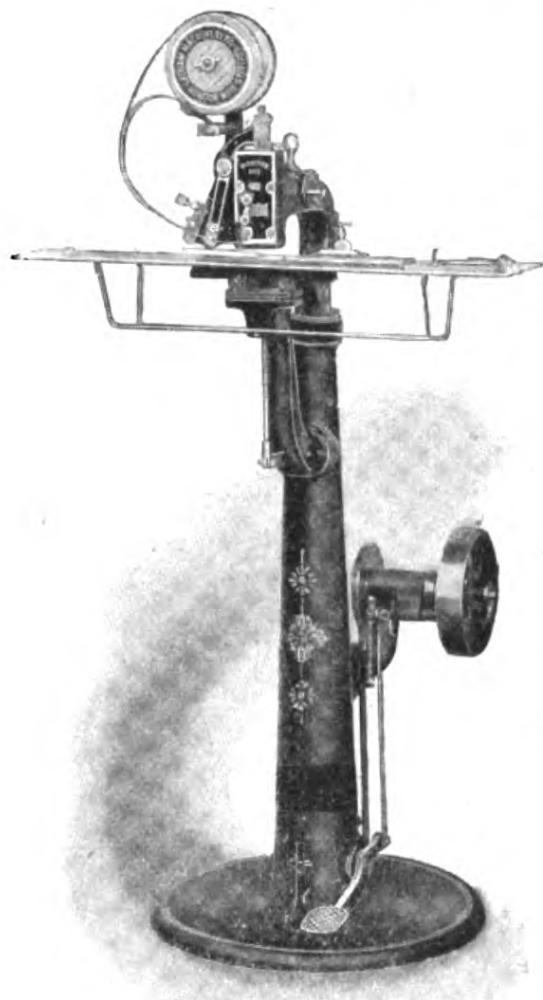

No. 3 Monitor Wire Stitcher.
Capacity, $\frac{1}{4}$ inch.

No. 3 MONITOR WIRE STITCHER.

This No. 3 Monitor is provided with all the improvements as on the more expensive stitchers, and will do stitching as neatly and as quickly.

It is built on a leverage movement, is very simple, does not get out of order nor break. With care this machine will earn its purchase price in a few weeks.

*For Prices and Weights of
Monitor Automatic Wire Stitchers,
see page 532.*

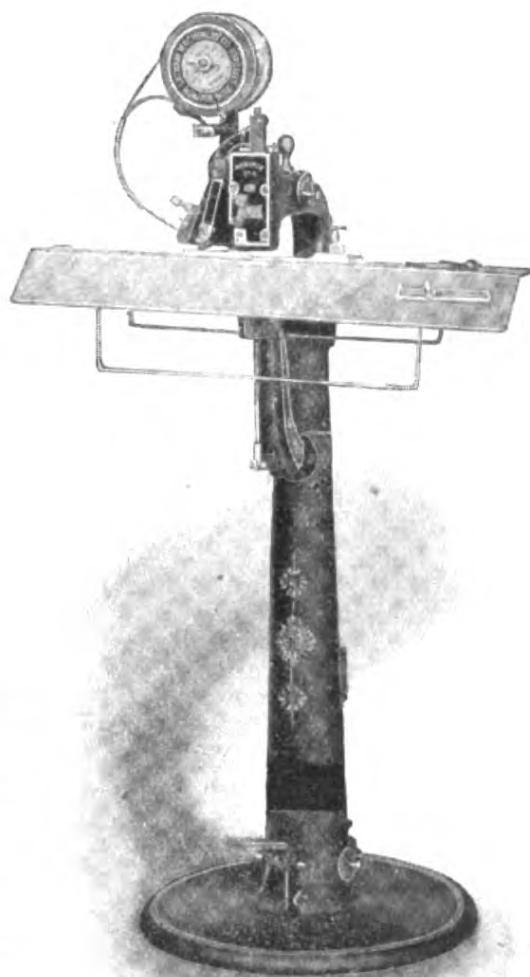

No. 4 Monitor Wire Stitcher for Foot
Power.
Capacity, $\frac{1}{4}$ inch.

No. 4 MONITOR WIRE STITCHER.

For Foot Power.

To reach the demand of small offices not provided with power, we herewith show a small foot-power stitcher at a price to bring it within the range of all medium-sized offices.

It feeds direct from a spool, making its own staples (at a cost of less than two cents per thousand). Will stitch both flat and saddle work without change of parts for different thicknesses of work or different sizes of wire. It has its own pedestal, similar to our power machines, and is of the same high standard of workmanship and material.

Uses thick and thin round wire from Nos. 25 to 30.

BRUCE TYPE FOUNDRY, 13 CHAMBERS STREET, NEW YORK.

EVERYTHING FOR THE PRINTER.

MONITOR AUTOMATIC WIRE STITCHERS.

(Continued.)

PRICES, WEIGHTS AND CAPACITIES OF MONITOR AUTOMATIC WIRE STITCHERS.

		Weight Boxed.	List Price.
No. 00	Twentieth Century—combined roll and straight feed; capacity, 2 sheets to 1 3/8 inches; uses 25 round wire, 19x21 1/2 flat wire 680 lbs.	\$700 00
No. 0	Twentieth Century—combined roll and straight feed; automatic clamp; capacity, 1/4 inch to 1 3/8 inches; uses 19x21 1/2 flat wire; flat work only. 575 lbs.	600 00
No. 1	Twentieth Century—combined roll and straight feed; capacity, 2 sheets to 7/8 inch; uses 25, 26, 27, 28 and 30 round wire, 20x25 flat wire 450 lbs.	450 00
No. 1 1/2	Twentieth Century—combined roll and straight feed; capacity, 2 sheets to 3/8 inch; uses 25, 26, 27, 28 and 30 round wire, 20x25 flat wire 400 lbs.	300 00
No. 1 3/4	Roll Feed—capacity, 2 sheets to 1/2 inch; uses 25, 26, 27, 28 and 30 round wire, 20x25 flat wire 375 lbs.	275 00
No. 2	Roll Feed—capacity, 2 sheets to 3/8 inch; uses 25, 26, 27, 28 and 30 round wire, 20x25 flat wire 350 lbs.	200 00
No. 2 1/2	Roll Feed Calendar Machine—capacity, 2 sheets to 1/4 inch; uses 25, 26, 27, 28 and 30 round wire; length of arm, straight back, 11 inches; sloped down, 16 inches 340 lbs.	175 00
No. 3	Direct Feed—same pattern as No. 4, with power added; capacity, 2 sheets to 1/4 inch; uses 25, 26, 27, 28 and 30 round wire 300 lbs.	150 00
No. 4	Direct Feed (Treadle)—capacity, 2 sheets to 1/4 inch; uses 25, 26, 27, 28 and 30 round wire 270 lbs.	100 00

All of the above have flat and saddle table except No. 0

TENNIS BOOK-SEWING MACHINE.

Designed for stitching blank books of every kind, and pamphlets and books not exceeding a thickness of three-eighths inch. Will sew through back or center, making stitches one-inch, half-inch, or quarter-inch long. Books sewed by this method are durable, and open perfectly. This machine is in use in almost every prominent blank-book factory in the United States.

In ordering steam power it is necessary to state diameter of shaft from which belt will be run to machine.

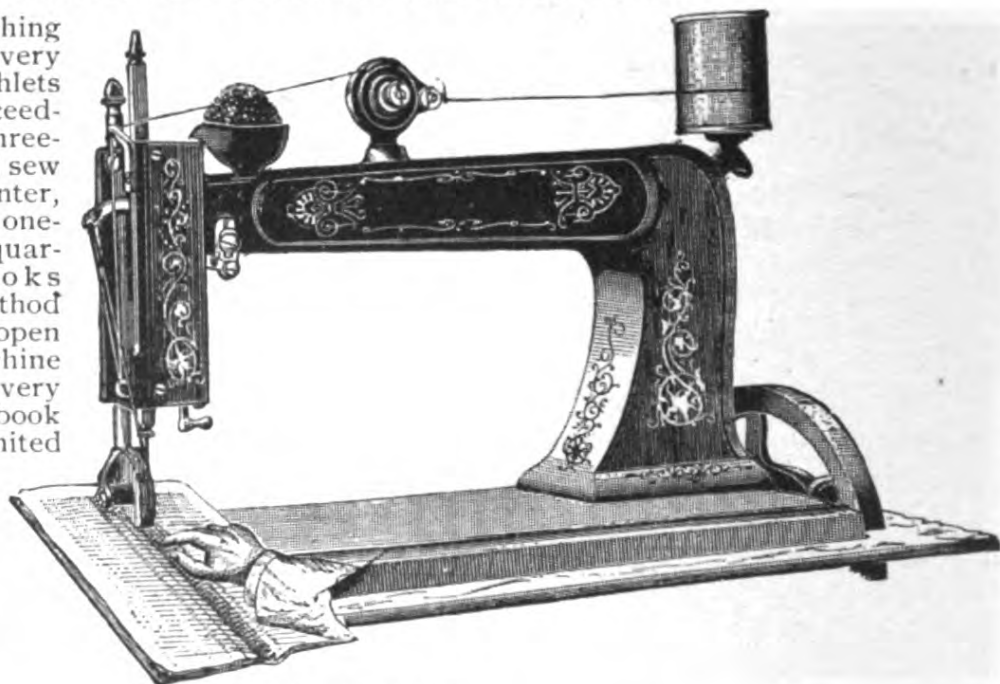

Length of Stitches.

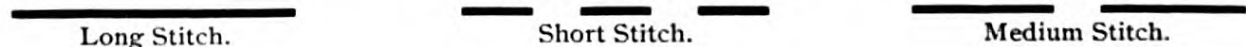

For foot power, with stand and table \$60 00
 For steam power, with variable speed, stand and pulleys, complete 70 00

Prices are strictly net f. o. b. factory.

BRUCE TYPE FOUNDRY, 13 CHAMBERS STREET, NEW YORK



**No. 6 ACME
TREADLE
STAPLE BINDER.**

**The Only Staple Binders
Which Will Not Clog.**

The No. 6 Acme Wire Staple Binder does a greater range of work, and does better work, than any other staple binder. At one stroke of the treadle it drives, clinches and releases the staple, each operation being independent, though continuous. It holds two hundred and fifty staples at a charge, and round or flat and fine or coarse staples may be used. Staples are fed automatically to driver by positive pressure on both legs, and clogging is prevented by a device which effectually prevents more than one staple getting under the driver at a time. The clinch is perfect on any thickness. There is ample room for putting in and taking out work, as the driver arm lifts more than an inch above the table after each clinch. There is a space of 8½ inches under the arm for calendar work. The treadle has a positive movement. Every machine is furnished with a strong iron stand. Will bind to a thickness of ¼ inch through any kind of paper, and is furnished with both flat and saddle-back tables, with gauges on the flat bed. For hard or coated papers, when the work is heavy, flat wire staples are used.

Acme Staple Binder No. 6.
For treadle, with flat and saddle tables.

Price, \$40.00

PRICES OF ACME TREADLE STAPLE BINDERS.

- No. 6 Acme Wire Staple Binder, capacity ¼-inch and under, on all kinds of paper, for round or flat wire, with table and treadle complete \$40 00
No. 4 Acme Wire Staple Binder, capacity ¼-inch and under, on ordinary printing paper, for round fine wire only, with table and treadle complete 27 00

For prices of Staples, see following page.

No. 4 ACME TREADLE STAPLE BINDER.

**The Only Staple Binders
Which Will Not Clog.**

The No. 4 Acme is very similar in appearance to the No. 6, and will stitch the same thickness on ordinary paper, but it uses only round fine staples, which cannot be used successfully on coated or filled paper unless such work is light. This machine is specially adapted for stapling the average run of pamphlets, calendars, sample work, etc. It does both flat and saddle-back work. It has the device for prevention of clogging, and the clinching is done by the pressure of the blade while driving the staple. Holds two hundred and fifty staples at a charge.

**UTILITY OF THESE
MACHINES.**

The addition of one of the Acme Treadle Staple Binders to the plant of small or moderate-sized printing offices, in towns in which there are no binderies, will make it easy and profitable to bind pamphlets, receipt books and other work. In towns where there are binderies they enable printers to save time, save handling of stock, and to avoid losses and damage in transit. All the staple binding machines in use were invented by one man, and the Acmes are the latest and most efficient. Like all such machines there is a certain knack to be acquired in order to handle them to the best advantage. Operators should read directions (which accompany the machines) very carefully.

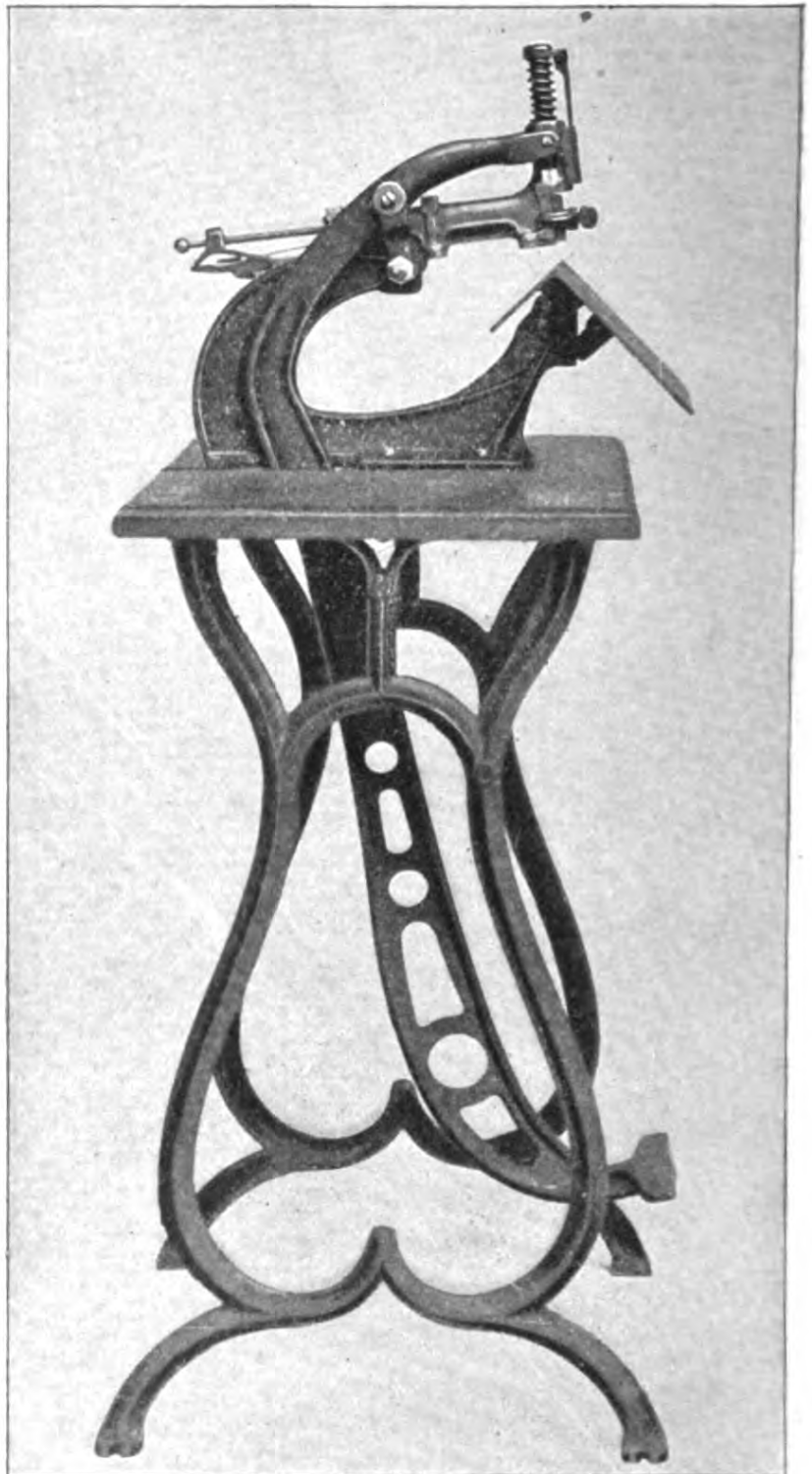

Acme Staple Binder No. 4.

Price, \$27.00

STAPLES FOR ACME BINDERS.

For Acme Binder No. 6: No. 20, $\frac{3}{16}$ inch, round; No. 21, $\frac{1}{4}$ -inch, round; No. 22, $\frac{5}{16}$ -inch, round; No. 23, $\frac{1}{4}$ -inch, flat; No. 24, $\frac{5}{16}$ -inch, flat—per box of 5000 of one size	\$1 25
For No. 4: No. 20, $\frac{3}{16}$ -inch, round; No. 21, $\frac{1}{4}$ -inch, round, and No. 22, $\frac{5}{16}$ -inch, round—per box of 5000 of one size	1 25



**ACME
STAPLE BINDER
No. 1.**

The most satisfactory low-priced staple binder made. *It will not clog*, as only one staple can get under the driver at one time. The frame swings on a pivot, and lifts high enough to give ample room for putting in and taking out the work—an advantage not obtainable on other low-priced staple binders. It holds one hundred staples at a charge. Binds $\frac{1}{4}$ -inch and under. The staple is fed automatically under the driver, which descends and drives it through the paper, the pressure clinching the staple tight on the under side. Uses flat staples only.

Price \$6 00
 Staples: No. 23A, $\frac{1}{4}$ -inch, flat; No. 24A, $\frac{5}{16}$ -inch, flat—per box of 5000 of one size . . . 1 25

**SURE SHOT
STAPLE
BINDER
No. 1.**

The most reliable binder for office use. Holds one hundred staples at a charge. Works on the same principle as the Acme No. 1, described above, but has no lever. Binds from two to fifty sheets.



Price \$3 00
 Staples: No. 23A, $\frac{1}{4}$ -inch; No. 24A, $\frac{5}{16}$ -inch—per box of 5000 of one size 1 25

BRUCE TYPE FOUNDRY, 13 CHAMBERS STREET, NEW YORK.

**BREECH LOADER
STAPLE BINDER.**

This is a handy machine for office use. Can be put to a great variety of uses. Binds paper or pamphlets from two to fifty sheets with wire staples; holds one hundred staples at a charge; feeds them out automatically; inserts them into the work, and clinches them on the under side.

Price \$3 00
Staples: C, $\frac{3}{16}$ -inch; D, $\frac{1}{4}$ -inch; E, $\frac{5}{16}$ -inch—per box of 1000 0 50

Only one size of staples in a box.

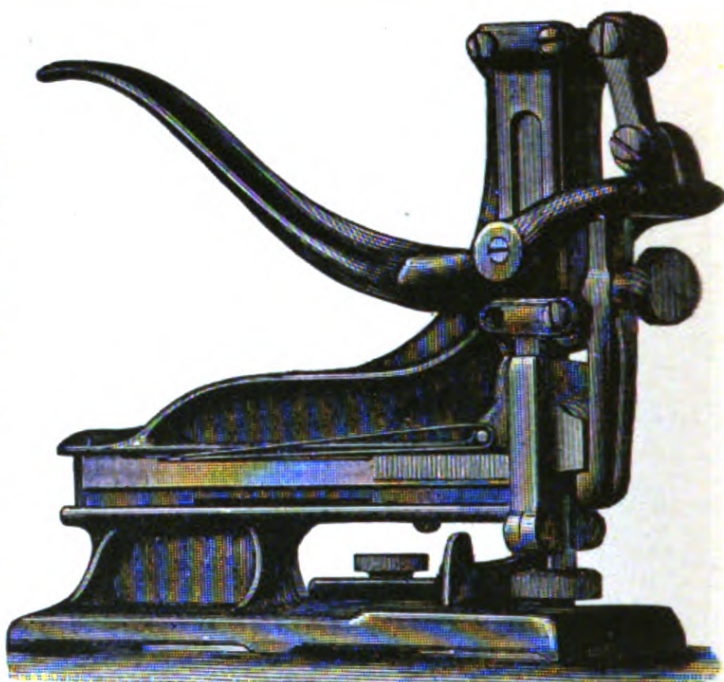

**HERCULES
WIRE STAPLE
BINDER.**

For Hand or Treadle.

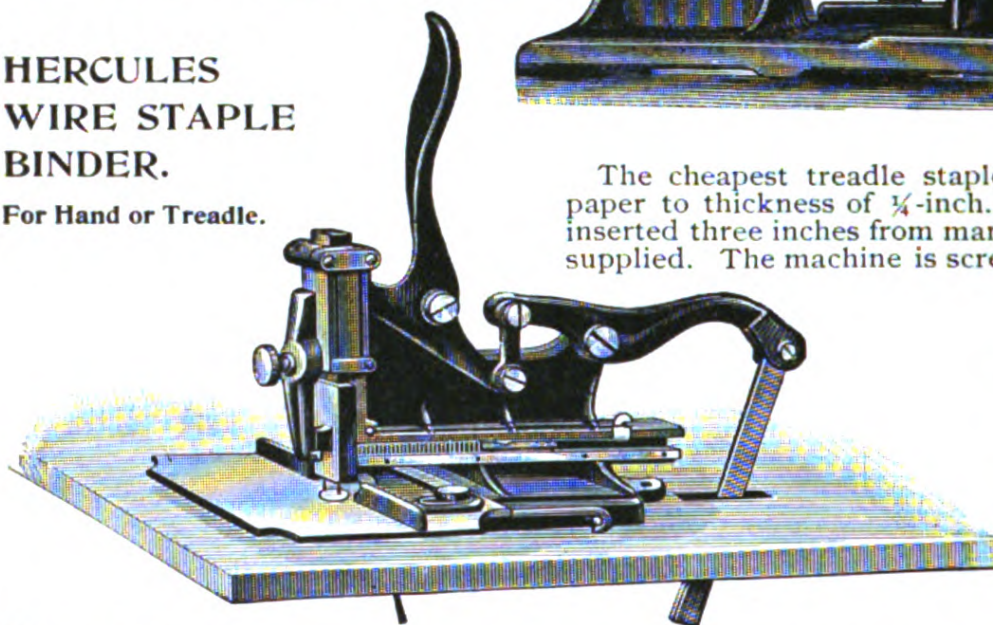

The cheapest treadle staple binder. Binds paper to thickness of $\frac{1}{4}$ -inch. Staples can be inserted three inches from margin. No table is supplied. The machine is screwed on a bench, and the treadle is screwed to the floor, connecting by means of a rod and spring.

Sold also for hand power only. Only one size of staples in a box.

Price, with treadle \$10 00
Staples: F, $\frac{3}{16}$ -in.; G, $\frac{1}{4}$ -in.; H, $\frac{5}{16}$ -in.; K, $\frac{3}{8}$ -in.—per box of 5000 of one size 1 25

OTHER STAPLE BINDERS.

No. 7 Staple Binder binds paper $\frac{5}{16}$ inch thick. Complete with table and treadle . . . \$32 00
No. 9 Staple Binder binds paper $\frac{1}{4}$ -inch thick. Complete with table and treadle . . . 36 00
No. 8 Saddle Back Staple Binder takes $\frac{3}{16}$ -inch staples only; designed for saddle-back work, but will take flat work by adding flat table; with saddle back only, \$30 00; with flat and saddle-back tables 31 50
Lightning Staple Binder No. 1 staples through $\frac{1}{4}$ -inch paper; No. 2 staples through $\frac{5}{16}$ -inch paper; each complete with treadle 24 00

WIRE STAPLES.

The following are the prices of staples for Staple Binders not illustrated:
For No. 9 Staple Binder: Staples No. 1 $\frac{1}{2}$, $\frac{3}{16}$ -inch long; No. 2, $\frac{1}{4}$ -inch long; No. 3, $\frac{5}{16}$ -inch long—per box of 5000 of one size \$1 25
For No. 8 Saddle Back Staple Binder: Staples No. 1, $\frac{3}{16}$ -inch long—per box of 5000 1 25
For No. 7 Staple Binder: Staples No. 4, $\frac{3}{16}$ -inch long; No. 5, $\frac{1}{4}$ -inch long; No. 6, $\frac{5}{16}$ -inch long; No. 6 $\frac{1}{2}$, $\frac{3}{8}$ -inch long—per box of 5000 of one size 1 25
For Lightning Staple Binder No. 1: Staples No. 7, $\frac{3}{16}$ -inch long; No. 8, $\frac{1}{4}$ -inch long; No. 9, $\frac{5}{16}$ -inch long—per box of 5000 of one size 1 25
For Lightning Staple Binder No. 2: Staples No. 10, $\frac{3}{8}$ -inch long; No. 11, $\frac{5}{16}$ -inch long; No. 12, $\frac{1}{2}$ -inch long—per box of 5000 of one size 1 25

BRUCE TYPE FOUNDRY, 13 CHAMBERS STREET, NEW YORK.

EVERYTHING FOR THE PRINTER.

No. 4 PUNCHING AND HAND EYELETING MACHINE.

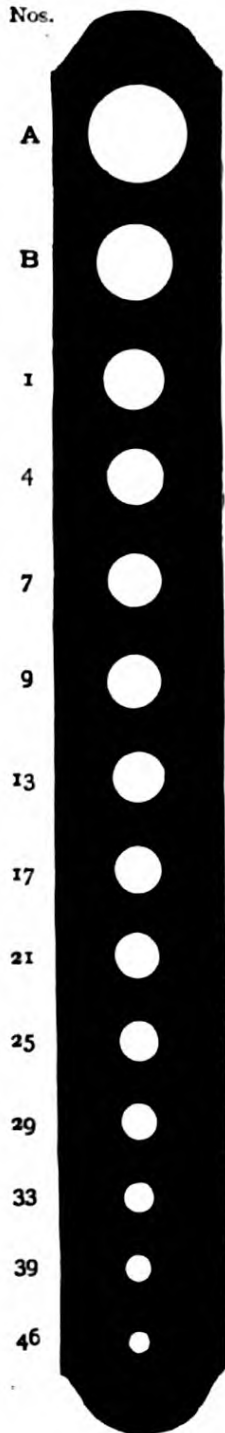

Can be used for Eyeletting by Hand by
Substituting Punches for Eyelet Sets.



Punch and Die.

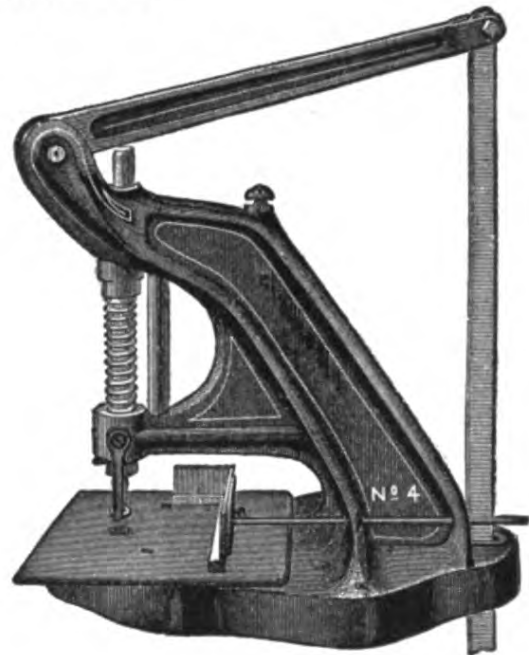

This is the proper machine to use with eyeletting machines. Except on cloth, good work cannot be done unless the hole is punched out *clean* before eyeletting. The No. 4 Machine will do work up to $\frac{3}{8}$ -inch diameter (No. 3 Calendar Eyelet) and has a reach of $6\frac{1}{2}$ inches back of plunger, and an adjustable gauge for all kinds of work.

By removing the punch and die and substituting an eyelet set, this machine may be used for eyeletting by hand feed, and will do perfect work.

No. 4 Punching Machine, with treadle, and one punch and die	\$20 00
Extra punch and die, per pair	2 50
Eyelet set, per pair	2 50

COMBINED EYELET PUNCH AND SET.



An indispensable tool in the printing office. Punches the hole and sets the eyelet. Takes only one size of eyelet (No. 2 Skirt).

Price, complete	\$2 25
Eyelets, per box of 1000	0 50

Sizes of punches and dies correspond with eyelets made. Order by number.

BRUCE TYPE FOUNDRY, 13 CHAMBERS STREET, NEW YORK.

EVERYTHING FOR THE PRINTER.

FRANKLIN HAND PERFORATOR.

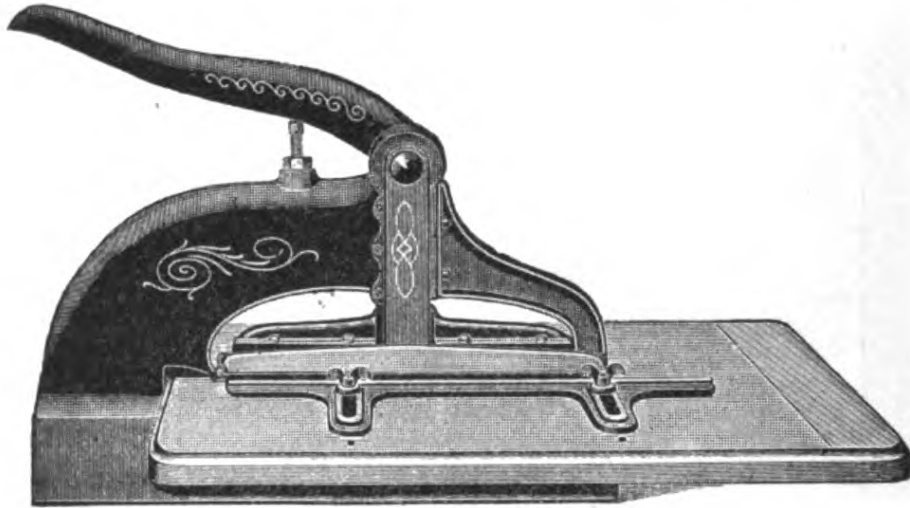

Perforates ten inches, and is provided with gauges on both sides, so that the sheets may be turned and fed in again, making a continuous perforated line of twenty inches. The pins make round holes, like the perforations on a sheet of postage stamps. Fifteen holes to an inch.

Hand Perforator, 10 inches \$25 00

STIMPSON LEVER AND TREADLE ROUND HOLE PERFORATOR.

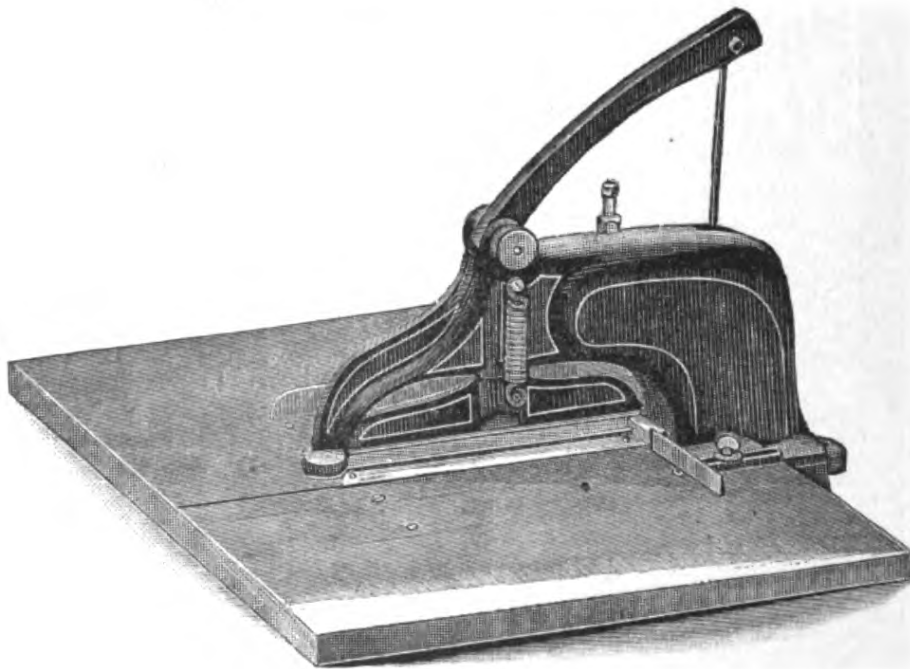

In every respect a perfect and superior machine, in keeping with the reputation of the makers, and well worth the price asked.

Perforators 10 inches with treadle \$40 00

BRUCE TYPE FOUNDRY, 13 CHAMBERS STREET, NEW YORK.

EVERYTHING FOR THE PRINTER.

**PRINTERS' SAW TABLE,
With Shoot-Board Attached.**

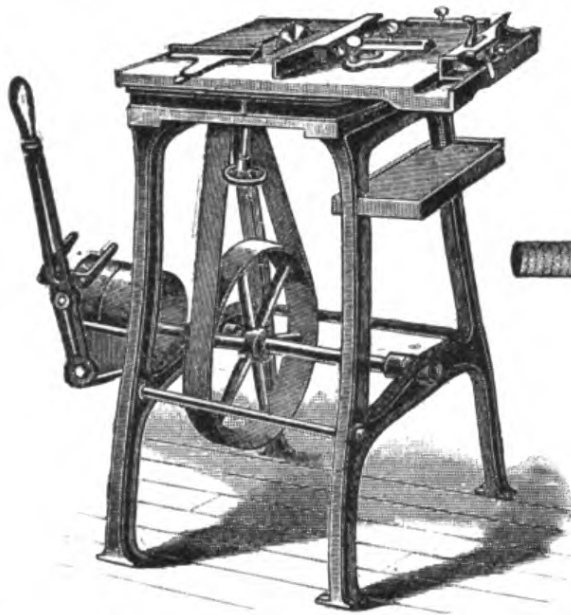

A very necessary machine in large printing offices. It will saw wood, metal or brass, and will trim wood and metal accurately from the merest shave upward. It affords the quickest and most accurate method of cutting slugs, furniture, thick brass rule and

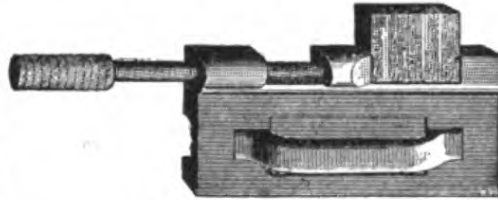

Attachment for Cutting Linotype Slugs.

plates, and as it is fitted in the most complete manner with gauges, all trimming and cutting is done with perfect trueness and squareness. An attachment for sawing linotype slugs is furnished for \$15.00 extra.

This is a thoroughly well-built machine, equal to similar machines used by electrotypers, made of iron and steel, with accurate adjustable gauges. The saw is raised or

lowered by means of a clamp-screw set under the table. The countershaft is attached to the saw, and should not run less than four hundred revolutions per minute. The driving pulley is 7 inches in diameter, for 2½-inch belt. Size of table is 18×24 inches, height 40 inches, and floor space occupied 24×32 inches.

lowered by means of a clamp-screw set under the table. The countershaft is attached to the saw, and should not run less than four hundred revolutions per minute. The driving pulley is 7 inches in diameter, for 2½-inch belt. Size of table is 18×24 inches, height 40 inches, and floor space occupied 24×32 inches.

- Saw table with shoot-board \$85 00
- Saw table without shoot-board 70 00
- No. 1. Attachment for sawing linotype slugs, extra 15 00
- No. 2. Attachment for sawing linotype slugs, for quick work, extra 25 00

COMBINATION SHUTEBOARD AND TYPE-HIGH MACHINE.

This machine will take blocks of ten inches wide and any length. The carriage or guide frame for plane being movable from side to side while operating, blocks of the full width of the bed can be shaved at one locking. The cuts or plates are laid face downward on the bed, locked, and then shaved until the knife or file cuts no more, when they will be even type-high. If blocks are too low, lay sheets of paper or cards below them to raise high enough for shaving, and afterwards glue these sheets to bottom of cut, or place them between plate and wood.

Patented,
January, 1894;
December, 1895.

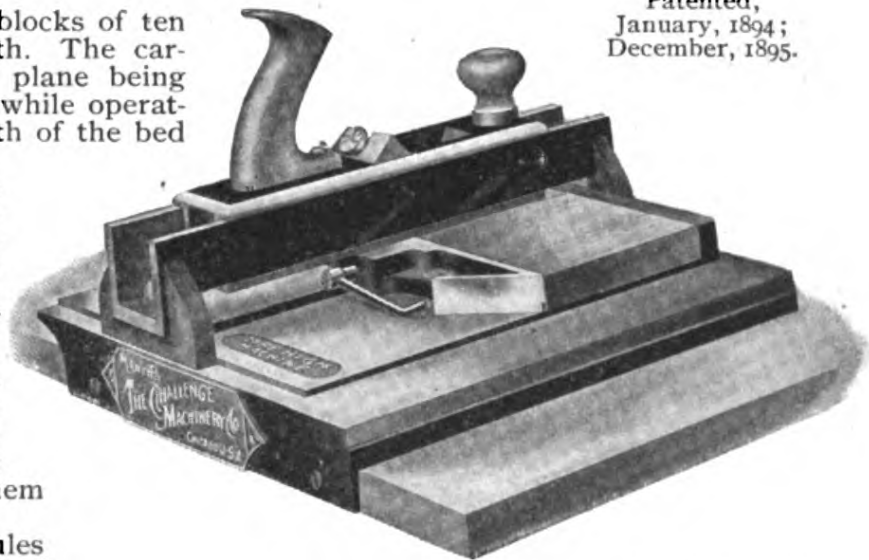

Three machines in one—Combination Shuteboard, Type-High Planer, Shaver and Miter Cutter.

For trimming slugs, rules or furniture (wood or metal of any size), cutting miters and squaring the sides of blocks, the guide frame is taken off and the plane used upon the side of the bed. It can be used as a bench vise, being handy for holding blocks when you want to take off or put on an electrotype plate. For warped blocks, the plates should be taken off, both top and bottom shaved and the plate remounted.

- Complete, with two planes (one file plane, one knife plane) \$25 00
- Extra files, each 0 75

BRUCE TYPE FOUNDRY, 13 CHAMBERS STREET, NEW YORK.

EVERYTHING FOR THE PRINTER.

AMERICAN LEAD AND RULE CUTTER No. 3.

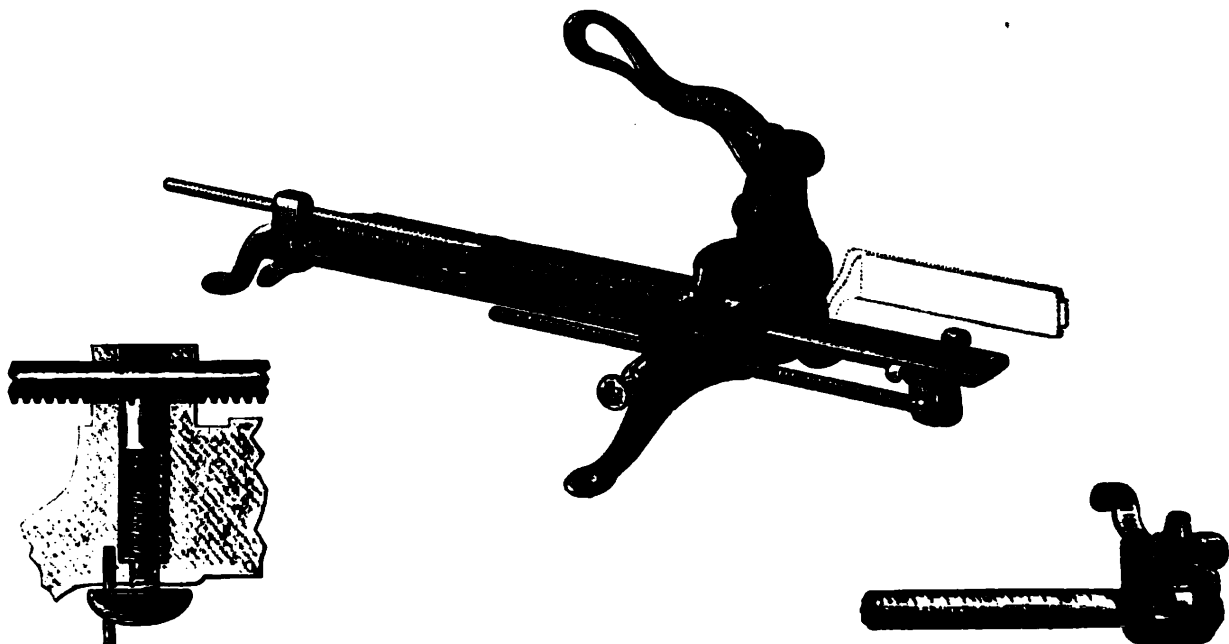

Gauge Lock.

WHY IT IS THE BEST.

Micrometer Gauge.

The gauges can be set instantly. They are absolutely positive. They are accurate, and guaranteed to remain so. They can be set to Nonpareils as well as Picas. The front gauge can also be set quickly and positively from one point to forty-eight Picas by points. It is impossible for either gauge to slip, or for material, however thin, to get under the bed gauge. The bed and gauge rods are graduated to Picas and numbered every five ems, the back gauge rod to indicate the measure when extended beyond the end of the bed. The cutting arrangement has no superior, being operated by a compound lever and provided with a shear cut for brass and a straight cut for leads.

The support to the right prevents any sag in the material between the front gauge and the knives. In cutting very short pieces it may be turned back out of the way, as indicated in cut. The machine rests on three feet, which insures a steady support no matter how uneven the surface on which it is placed. For accurate work this machine is without an equal. Material and workmanship the very best.

Capacity of bed gauge, up to 105 ems by Nonpareils; capacity of front gauge, up to 48 ems by points.

Price \$12 00

AMERICAN LEAD AND RULE CUTTER No. 2.

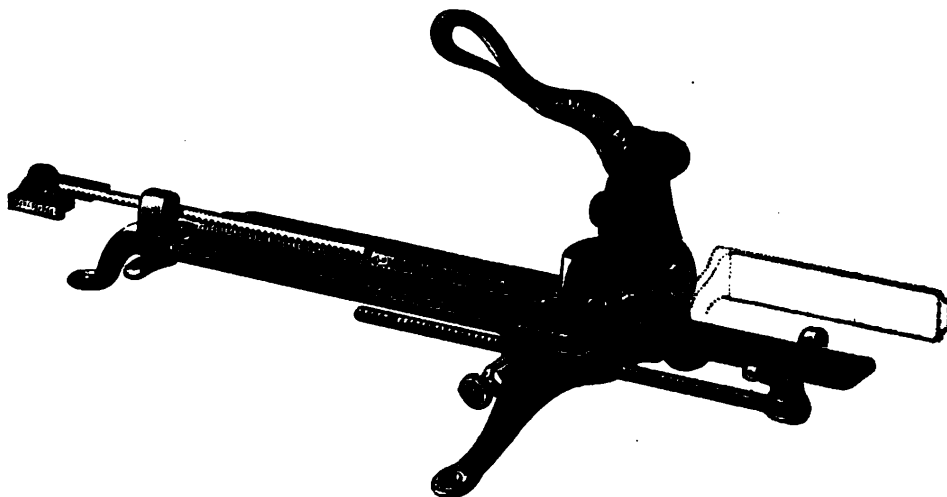

This cutter is the same as the American Lead and Rule Cutter No. 3, with the exception that the front gauge sets to Nonpareils only instead of to points, and is undoubtedly the best machine ever sold at the price.

Price \$10 00

BRUCE TYPE FOUNDRY, 13 CHAMBERS STREET, NEW YORK.

EVERYTHING FOR THE PRINTER.

AMERICAN LEAD AND RULE CUTTER No. 1.

This machine is very strong and compact. It is provided with a reversible bed gauge which is held in position as in a vise, the post through which the gauge-rod passes having a narrow slit in the top and a thumb-screw by means of which the rod is clamped quickly and securely. This cutter also has the grooved bed which, with corresponding projections on gauge-head, preclude the possibility of thin material getting under the gauge. The front gauge is held by a thumb-screw, as usual.

Material and construction unsurpassed—in fact, the best \$8.00 cutter made. Capacity of bed gauge, 13½ inches; capacity of front gauge, 6½ inches.

Price \$8 00

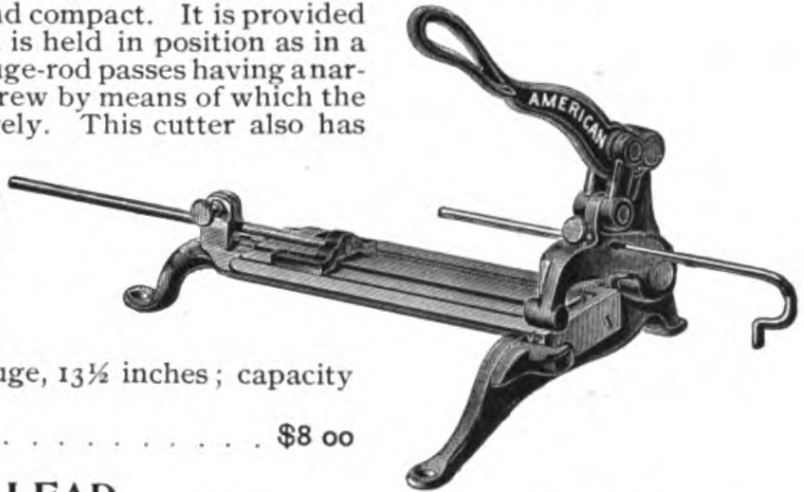

HANDY LEAD CUTTER.



Will cut leads and slugs six points thick, and, although not recommended as a rule cutter, will cut two-point brass rule. Has back and front gauges. Leads can be cut very rapidly and easily on this cutter by holding the lever and the handhold on frame in right hand, as in using hand shears. To get the best results this cutter should be screwed to bench or table.

Price \$4 00

CHANDLER & PRICE LEAD AND RULE CUTTER.

The bed and gauge are graduated to Picas.

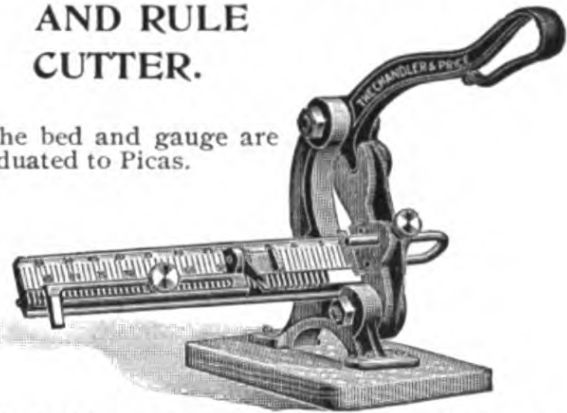

The bed is nearly vertical, and the lead or rule drops against the gauge edge by gravity, assuring a square cut.

Gauges 14 inches \$8 00

UTILITY LEAD CUTTER.

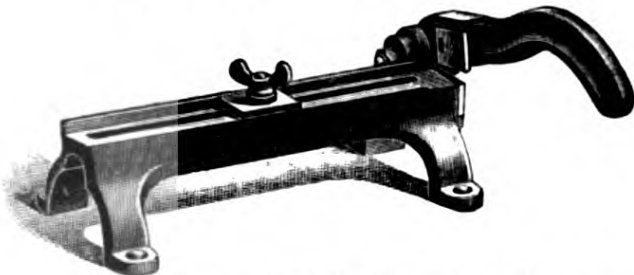

The strongest cheap lead cutter made. A reliable, cheap tool.

Price \$2 00

LEAD AND RULE CUTTERS.

No. 1 \$8 00
Gauges 12 inches.

No. 2 \$9 00
Graduated to Picas; gauges 12 in.

No. 3 (extra heavy) \$12 00
Bed, 13 in.; graduated to Picas; gauges 18 in.

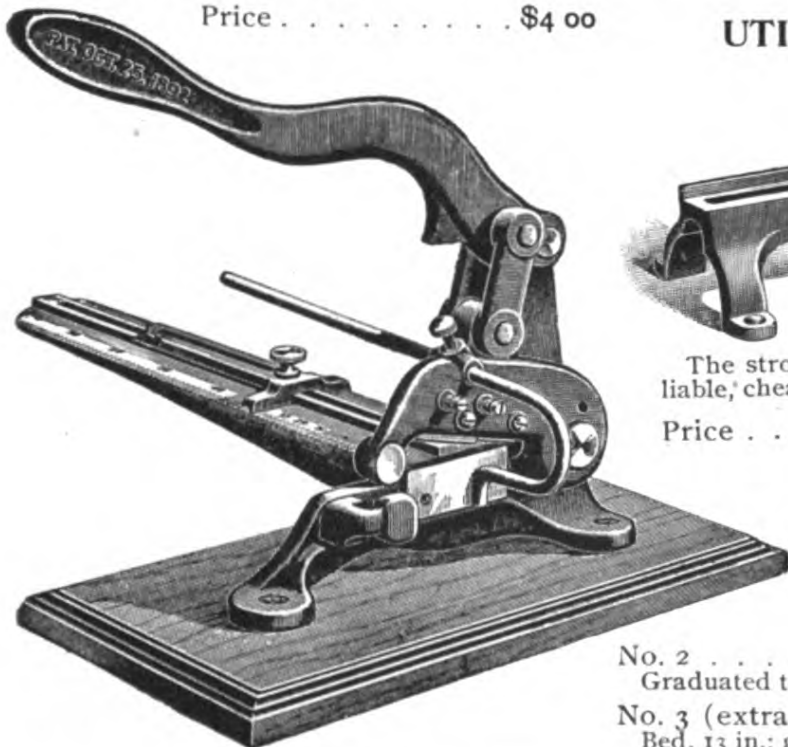

BRUCE TYPE FOUNDRY, 13 CHAMBERS STREET, NEW YORK.

EVERYTHING FOR THE PRINTER.

PATENT UPRIGHT MITER MACHINE.

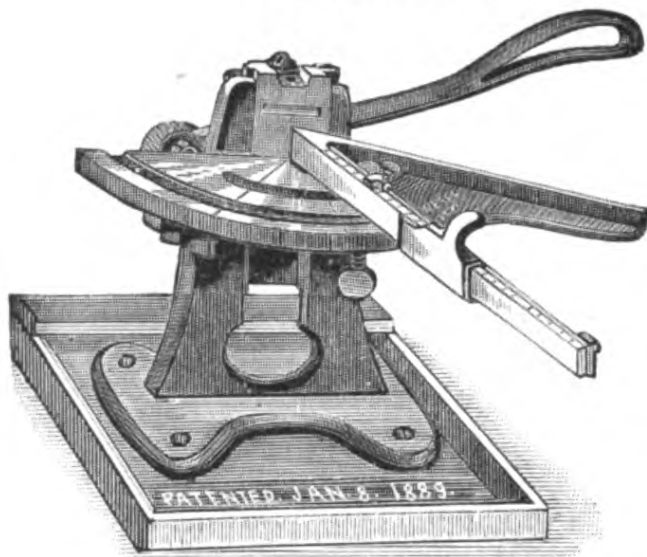

A strong, well-built, accurate machine. The cutting or shaving head has a positive up-and-down motion, and must cut as much at the bottom as at the top, as it cannot slip. The knife is regulated by set-screw. The sliding gauge is the best of its kind, enabling the operator to feed the rule up to the knife, but affords a positive check at the point where the desired length is reached. The bed is graduated, and is made movable, so that the whole cutting-edge of knife can be used. This machine is mounted in a strong, shallow, wooden box, which catches the shavings, and has at the front end an emery board on which the burr of the rules may be rubbed off.

With Sliding Gauge \$13 00
 With Micrometer Point-System
 Gauge 20 00

GOLDING UPRIGHT MITERER.

This machine differs in principle from the Patent Miterer (described on this page) in this: the rule is held stationary, and the knife is fed up to it, while in the Patent Miterer the knife is stationary and the rule is fed to it. The knife of the Golding Miterer is movable, but it is pivoted in such a way as to enable it to make a positive downward cut the same at the bottom as at the top. The knife adjustment is specially good. The bed is graduated and is made movable, so that the whole cutting edge of the knife may be used.

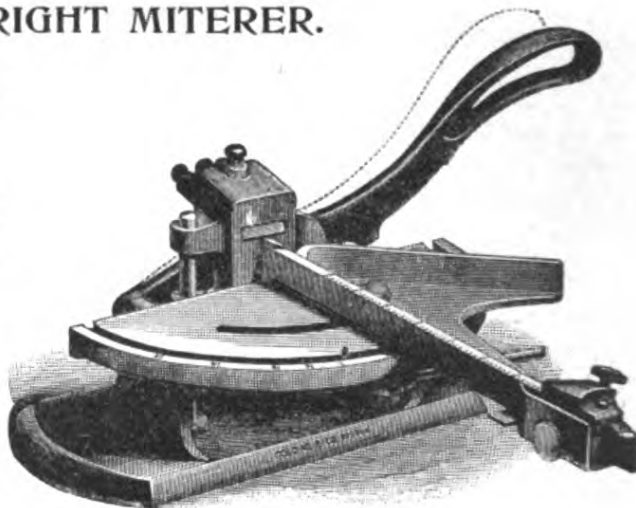

Price, boxed \$14 00

ELITE RULE BENDER.

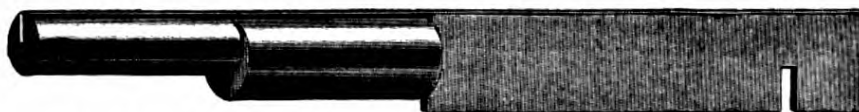

The blade is tool steel and the cylinders of brass. Bends rule from one to six points in thickness. The end of the rule is firmly held in the grooves in cylinder, and can be twisted into any shape.

Price, with instructions for rule bending \$2 00

THE BEST SAW FOR PRINTERS.

The Universal Sawing Machine is specially recommended as the best saw made for accurately cutting brass rule to labor-saving measure. The gauge of this machine can be set from one-half to fifty Picas, including all the halves in this measure.

BRUCE TYPE FOUNDRY, 13 CHAMBERS STREET, NEW YORK.

EVERYTHING FOR THE PRINTER.

GOLDING RULE-CURVING MACHINE.

This machine curves brass rule from one-quarter inch to eight inches in diameter by pressure exerted by the screw on curved brass plates, between which the rule is put at the proper place to get the required curve, as indicated by a scale engraved on the bed. Smaller curves can be made on this machine than on any other. An attachment is supplied for forming square corners as a substitute for mitered corners. Brass rule for curving or bending should be annealed. All brass rule made by us can be annealed to order at a slight extra charge.

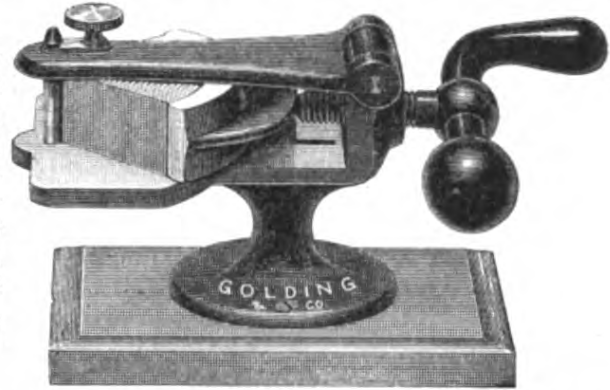

No. 1, curves one-quarter to four inches in diameter	\$12 00
No. 2, curves three-eighths to eight inches in diameter	18 00
Dies for forming square corners, per set	1 50

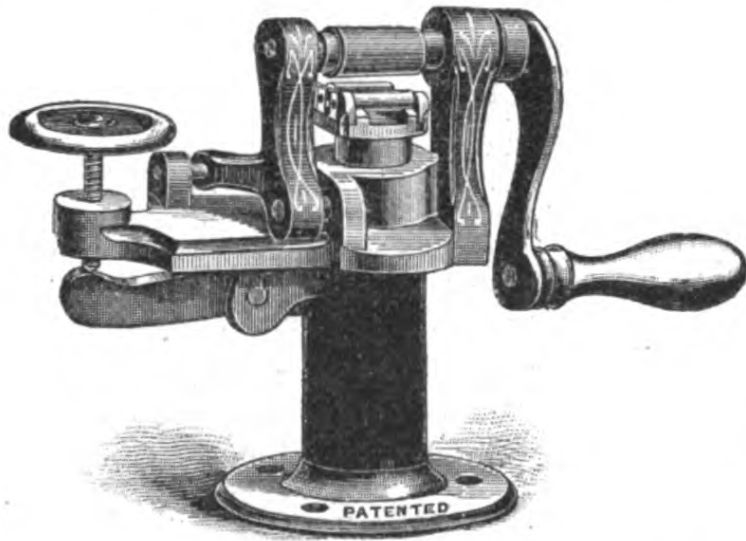

PRINTERS' CURVING MACHINE.

On this machine the curves are made by pressure between three iron rollers (two below and one on top), and the pressure is regulated by the screw at left hand side, which acts on a lever that raises or depresses the lower iron rollers. The action is very rapid, and, in the hands of an expert, accurate.

Price \$15 00

LITTLE GIANT RULE SHAPER.

The rule is held flat on the bed by the clamp (2). The gauge (5) is graduated to Picas by notches, and is regulated by the pointer (4), which engages in the notches. Five steel cutting tools of different angles are furnished with each machine. The cutting tool is held in the head (1). By turning the wheel the cutter is moved back and forth over the rule, sinking deeper at each cut, and when it completes the cut it is lifted automatically, ready for the next cut. If the rule is thinner than 12 points, the head (1) may be brought down to the rule by moving the lever (3). Any thickness of rule up to 12 point may be mitered. At each cut both sides of the miter are made, and join without further trimming. This machine is not designed for trimming the ends of leads and rules, and therefore does not supersede the upright miterer; but in offices where much mitering is done it will prove a time and rule saver, as it miters very rapidly.

Send for illustrated circular.

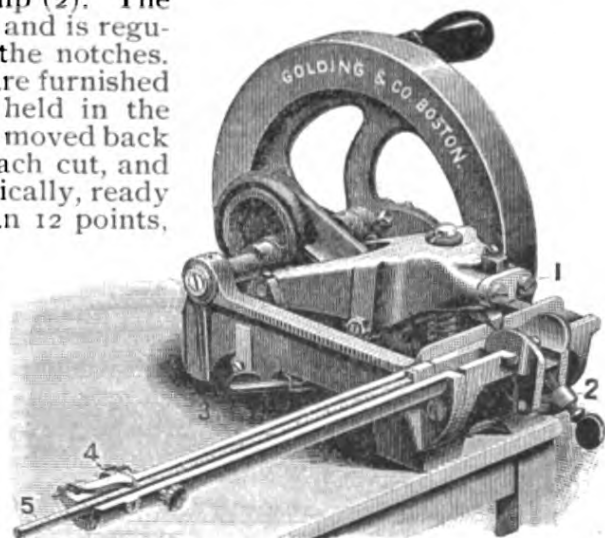

Price	\$35 00
Patent graduated gauge, extra	4 00

BRUCE TYPE FOUNDRY, 13 CHAMBERS STREET, NEW YORK.

EVERYTHING FOR THE PRINTER.

THE HORTON MAILER.

THE BEST MAILER ON THE MARKET.

Patented May 1, 1894
May 9, 1899

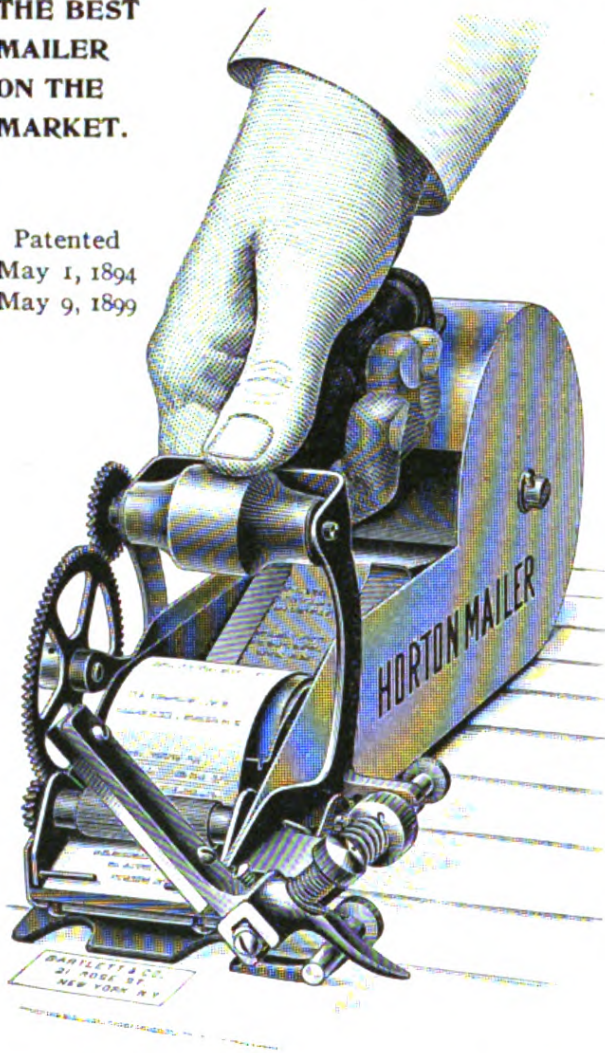

This is the best label-pasting mailer. It is quicker and more exact, because all its movements are positive. It is so simple that it can be worked rapidly and efficiently by the inexpert, while experts have addressed with it at the rate of 170 per minute. It is operated, as illustrated, by one hand, leaving the other entirely free to manipulate the papers or wrappers.

It guides and thoroughly pastes the slip, scrapes off all surplus paste, and sticks the label cleanly and firmly. The knives are thin and adjustable, with two cutting surfaces, and can be easily sharpened. The arrangements for adjusting knives with each other and regulating tension of knives are very exact.

It is very strongly made, and is the most durable of mailers.

When ordering mailer, don't forget to give width of mailing slip.

Slip guides furnished from 1 1/8 to 1 3/8 inches; taking all widths of mailing lists, not exceeding 10 1/2 Picas.

Price, with paste strainer, extra knives, screw driver and oil can, packed in a strong wooden box, net \$20 00

MUSTANG MAILER.

This mailer prints directly on the paper or envelope. The platen and its frame moves automatically, printing one address at a time. It will print three-line (8 point) addresses.

The Mustang Mailer occupies a space of 37 inches in length and 4 1/2 inches in width, and is made wholly of iron without springs or complications of any kind. Speed is regulated solely by the speed of operator in passing the papers to and from the mailer. The mail list is made up in galleys ten ems Pica wide on the inside.

Each galley holds seventy-five addresses. The weight of the machine is fifteen pounds, and of the galleys one pound.

Price \$10 00

MUSTANG MAILING GALLEY.

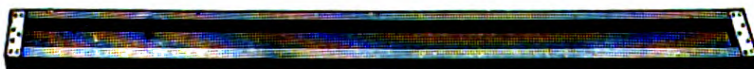

Zinc bottom \$0 50
Brass bottom 0 75

BRUCE TYPE FOUNDRY, 13 CHAMBERS STREET, NEW YORK.

EVERYTHING FOR THE PRINTER.

PRINTERS' SUPPLIES.

BODKINS.



No. 2, wood handle, needle steel,
each \$0 10

TWEEZERS.



This is good and cheap; polished steel; Nonpareil points.

No. 11, nickel-plated, each \$0 25



This is the best Tweezer procurable at the price; file point, steel, 4 inches long.

No. 5, nickel-plated, each \$0 50



These are the best made; tempered steel, nickel-plated, file-cut points and backs. No. 7 is 4 inches long; No. 8, 4 3/4 inches long.

No. 7, nickel-plated, 4 inches long, each \$0 75
No. 8, nickel-plated, 4 3/4 inches long, each 0 85



The only Tweezer that can be carried in the pocket with comfort and safety. It locks and unlocks automatically. Hold it points down and press between fingers gently, and it unlocks; hold it points up and bring points together, and it locks securely.

No. 9. Self-locking, nickel-plated, each \$0 90



When Tweezer is in use the Bodkin folds into it. When Bodkin is required, pressure on the file-cut arc shown in cut brings it out easily, and when extended it locks securely, and is as firm as an ordinary Bodkin. This is the latest and most satisfactory combination. Patent applied for.

No. 3. Combination Tweezer and Bodkin, nickel-plated, each \$1 00

COMPOSING AND MAKE-UP RULES.

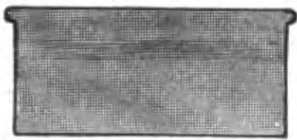

Steel Composing Rules, 15 ems and under, each \$0 25

Add 5 cents to above from 15 to 20 ems, and 10 cents extra from 20 to 25 ems.

Nickel plating, 15 cents extra.

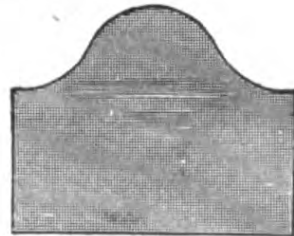

Steel Make-up Rules, 15 ems and under, each \$0 30

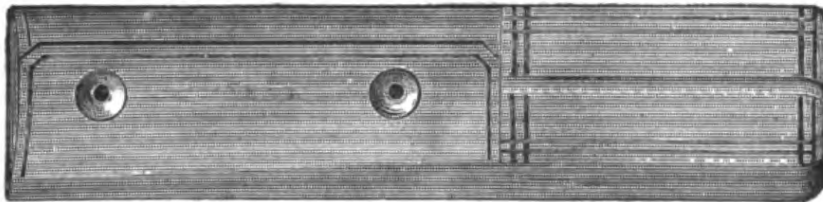

Set of 12 Steel Composing Rules, in leather case \$1 50

Sizes: 12, 13, 13 1/2, 14, 15, 16, 18, 21, 24, 26 1/2, 28, 30 ems.

BRUCE TYPE FOUNDRY, 13 CHAMBERS STREET, NEW YORK.

COMPOSING STICKS.

THE BUCKEYE.

Quick and easy to set; will not slip; lies flat; as secure as the Common Screw Stick, and easier to set than the Yankee Job Stick.

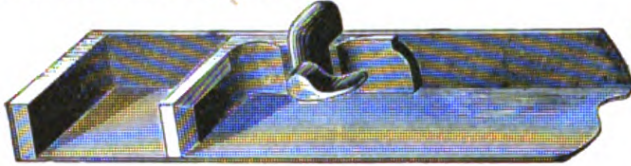

6 ins. × 2, 2¼ or 2½ ins. deep	..	\$0 90
8 ins. × 2, 2¼ or 2½ ins. deep	..	1 00
10 ins. × 2, 2¼ or 2½ ins. deep	..	1 20
12 ins. × 2, 2¼ or 2½ ins. deep	..	1 40
14 ins. × 2, 2¼ or 2½ ins. deep	..	1 60
16 ins. × 2, 2¼ or 2½ ins. deep	..	1 80
20 ins. × 2, 2¼ or 2½ ins. deep	..	2 20
24 ins. × 2, 2¼ or 2½ ins. deep	..	2 60

YANKEE JOB.

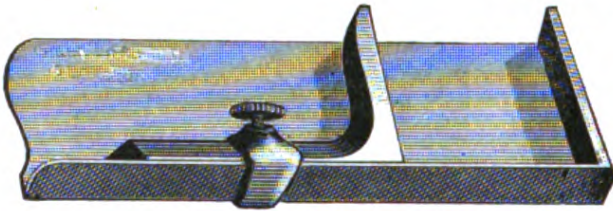

6 ins. × 2, 2¼ or 2½ ins. deep	..	\$0 75
8 ins. × 2, 2¼ or 2½ ins. deep	..	0 80
10 ins. × 2, 2¼ or 2½ ins. deep	..	1 00
12 ins. × 2, 2¼ or 2½ ins. deep	..	1 15
14 ins. × 2, 2¼ or 2½ ins. deep	..	1 30
16 ins. × 2, 2¼ or 2½ ins. deep	..	1 45
18 ins. × 2, 2¼ or 2½ ins. deep	..	1 60
20 ins. × 2, 2¼ or 2½ ins. deep	..	1 75

COMMON SCREW.

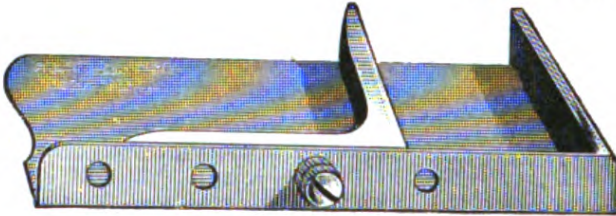

6 ins. × 2, 2¼ or 2½ ins. deep	..	\$0 75
8 ins. × 2, 2¼ or 2½ ins. deep	..	0 80
10 ins. × 2, 2¼ or 2½ ins. deep	..	1 00

Other sizes to order at same prices as Yankee Job Sticks.

THE GROVER.

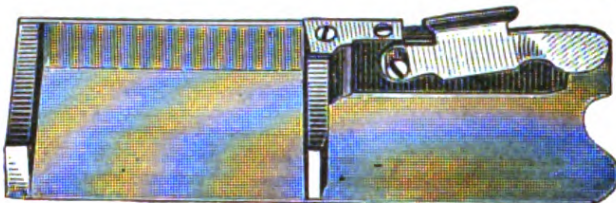

6 × 2¼ inches	..	\$0 90
8 × 2¼ inches	..	1 00
10 × 2¼ inches	..	1 20
10½ × 2½ inches (billhead)	..	1 60
12 × 2¼ inches	..	1 40
16 × 2¼ inches	..	1 80

Extra clasps, 10 cents; extra knees, 40 cents each.

"C" SLOT STICK.

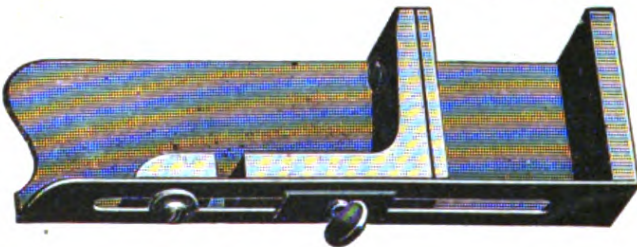

Has two entirely novel features: (1) The inside of face of the knee is adjustable, so that it can be squared up in case the knee wears; (2) The knee is in two sections, so that the Stick can be set to shorter measure without changing the full measure adjustment. See cut, which shows part of the knee at the left set for full measure, while the main part is set to a lesser measure.

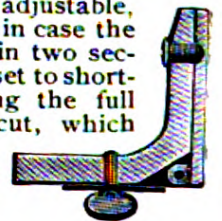

6 ins. × 2¼ ins. deep	..	\$1 15	10 ins. × 2¼ ins. deep	..	\$1 45
8 ins. × 2¼ ins. deep	..	1 25	12 ins. × 2¼ ins. deep	..	1 65

STANDARD JOB COMPOSING STICK.

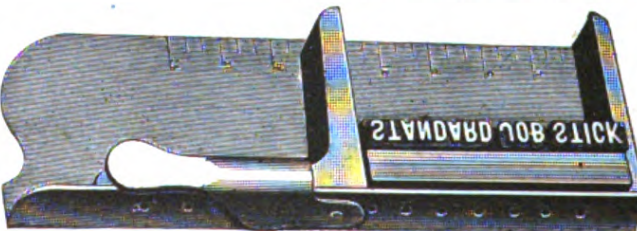

Sets instantly to Nonpareils or Picas, of the point system only, without the use of leads or quads, and once set cannot possibly slip.

	2 ins.	2¼ ins.	2½ ins.
6 inches	.. \$1 75	\$1 85	\$1 95
8 inches	.. 2 00	2 10	2 20
10 inches	.. 2 25	2 35	2 45
12 inches	.. 2 50	2 60	2 70

EVERYTHING FOR THE PRINTER.

AMERICAN JOB STICK.

This composing stick is constructed upon entirely new lines and is destined to become extremely popular. It is made with a series of notches in the back of the stick with corresponding steel teeth in the knee to engage in them, the knee being clamped to the back of the stick, as indicated in engraving. The knee is made with a diagonal brace which effectually prevents springing. This stick can be set to Nonpareils or Picas quicker and more accurately than any other, and it is impossible for the knee to slip or to spring. Just the thing for accurate tabular work. Has a hole near the end to hang it up by.

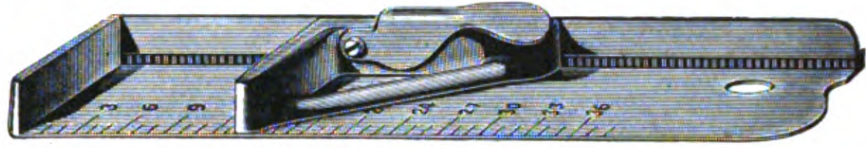

	2 Inches Deep.	2¼ Inches Deep.	2½ Inches Deep.
6-inch	\$1 75	\$1 85	\$1 95
8-inch	2 00	2 10	2 20
10-inch	2 25	2 35	2 45
12-inch	2 50	2 60	2 70
15-inch	3 00

Nickel plating, extra, 30 cents.

PERFECT NEWS STICKS.

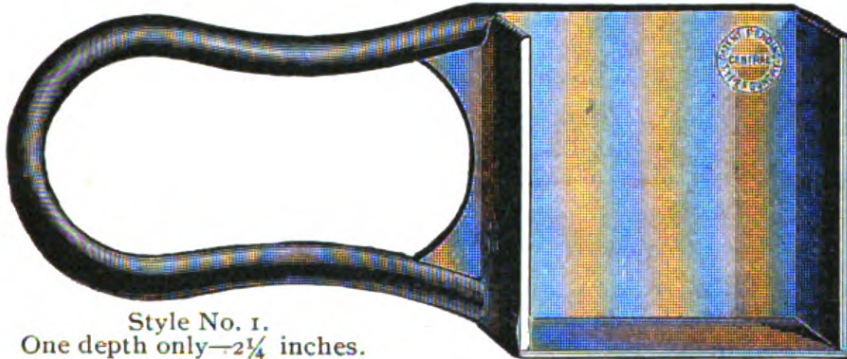

Style No. 1.
One depth only—2¼ inches.

These Sticks are made for setting one measure only, either 13 or 13½ ems Pica, and prevent all the annoyances due to variations in Sticks set inaccurately by careless compositors. It is undoubtedly the best Stick made for news measures.

Style No. 1 is made of best malleable iron; the handle and under side are japanned, so that the Stick cannot rust; the pan itself is milled out,

the sides being absolutely square and rigid, and altogether the Stick is as perfect as could be desired. Made one depth—2¼ inches—only, and for 13 or 13½ ems Pica measure.

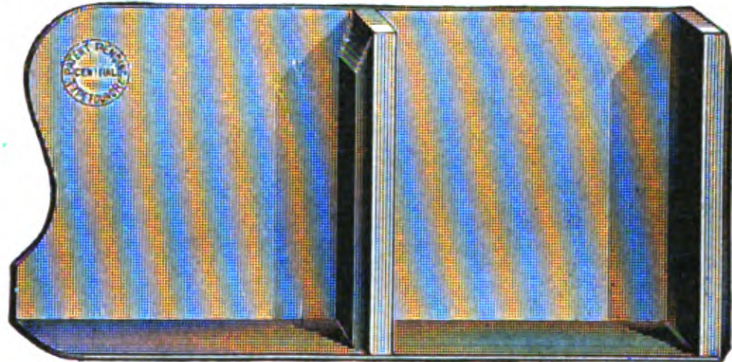

Style No. 2.

Style No. 2 is made of the best of steel, and the set bar or knee is riveted firmly to bottom and back of Stick. It is accurate in every respect.

These Sticks are made for 13 or 13½ ems Pica measure, and are 2¼ inches deep.

No. 1. Malleable Iron, milled, for 13 or 13½ ems Pica measure	\$0 75
No. 2. Steel-riveted, for 13 or 13½ ems Pica measure	0 80

WOODEN POSTER STICK.

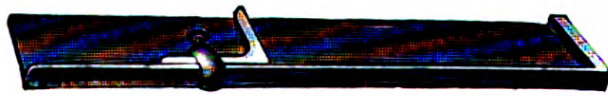

With brass-lined ends, iron knee and screw clamp.

16 inches	\$1 00
20 inches	1 10
24 inches	1 20
30 inches	1 35
36 inches	1 50
42 inches	1 80

PRINTERS' EYE SHADE.

Per dozen	\$1 50
Each	0 15

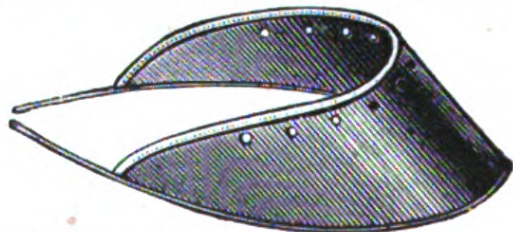

BRUCE TYPE FOUNDRY, 13 CHAMBERS STREET, NEW YORK.

EVERYTHING FOR THE PRINTER.

COMPOSING STICK RACK.

This Rack holds twelve Sticks, and can be attached to the wall or any other convenient place. The Sticks are held securely, and are preserved from the damage liable to them when "kicking about."

Each \$1 50

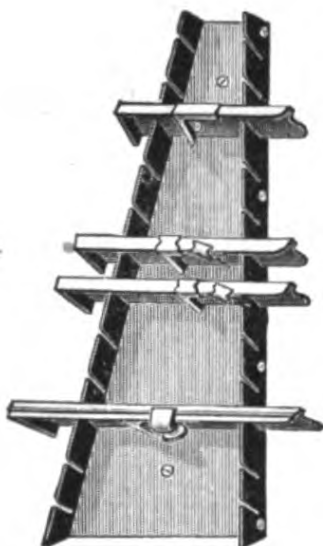

KELSEY COPY HOLDER.



Price, each \$0 75

BRASS LABEL HOLDER.



The utility of these Label Holders is apparent at a glance, especially when extra men are put on, as it enables them to locate the type quickly.

Size, 1x5 1/2 inches, per hundred, with cards and tacks complete \$2 75
 Size, 1x5 1/2 inches, per dozen (least quantity sold), complete 0 50

Other sizes furnished to order.

TYPE MEASURES.

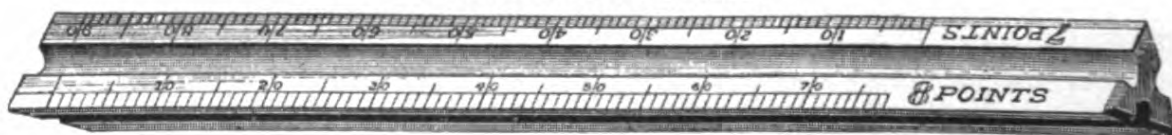

Boxwood Triangular Type Measure.

Boxwood, triangular shape, the best, 9 inches \$1 50
 Boxwood, triangular shape, the best, 18 inches 3 00

This Type Measure is superior to any, and is guaranteed to be accurate. The sides of the triangle are grooved, so that it is easily handled. It will measure any size from 5 1/2 Point to 18 Point, and all multiples of 6 Point.

Square Brass-Edged Wooden Type Scale, No. 120 \$0 30

Measures 5 1/2, 6, 7, 8, 9, 10, 11 and 12 Points, and has 12-inch scale.

Patent 12-inch Cardboard Type Scale \$0 25

Measures 4 1/2, 5, 5 1/2, 6, 7, 8, 9, 10, 11 and 12 Points, and has 12-inch scale.

Lincoln Type Measure, steel tape, 24 inches long, in German silver case, each \$2 00

Measures 376 lines of Agate (14 lines to the inch); 288 of 6 Point; 246 of 7 Point; 216 of 8 Point; 192 of 9 Point; 172 of 10 Point; 157 of 11 Point; 144 of 12 Point; and has a 24-inch scale, all plainly marked.



Exact size.

BRUCE TYPE FOUNDRY, 13 CHAMBERS STREET, NEW YORK.

EVERYTHING FOR THE PRINTER.

BRACKETS.

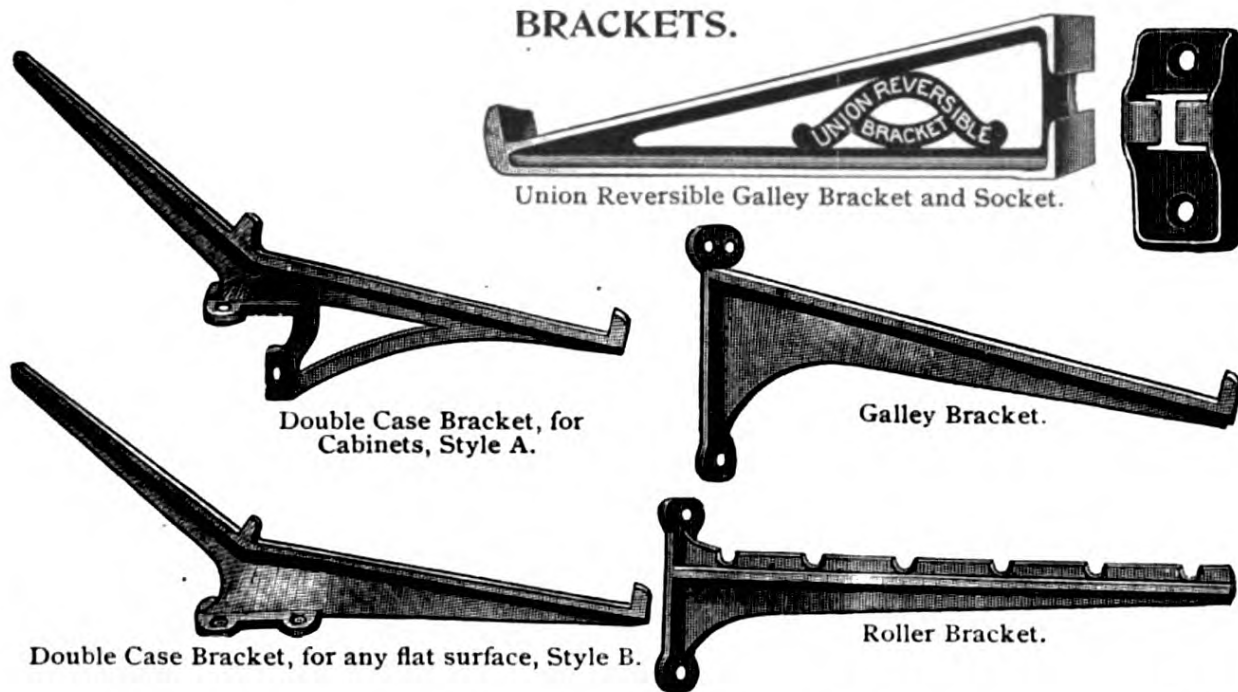

Double Case Brackets, style A, fit on end of Flat Top Cabinet, per pair	\$1 50
Double Case Brackets, style B, fit on any flat surface, per pair	1 25
Single Case Brackets, per pair	0 75
Galley Brackets, per pair	0 40
Roller Brackets, to hold six platen press rollers, per pair	0 50
Union Reversible Galley Brackets, with Sockets, per pair	0 60
Union Reversible Galley Brackets, with Sockets, per dozen pairs	6 00

CHALLENGE LAMP HOLDER.

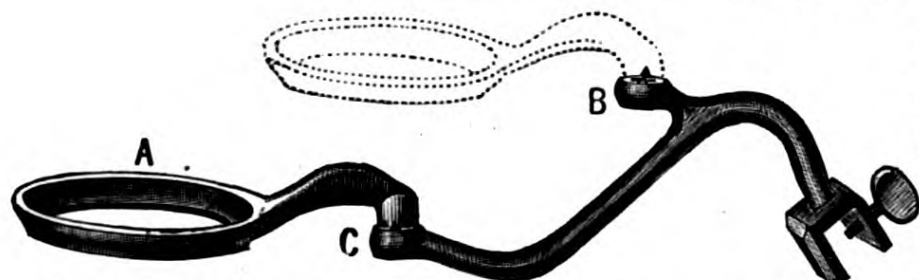

A most convenient and safe attachment for holding a lamp over the compositor's case. It will be readily understood by reference to the cut that the fount holder A can be instantly raised from C to B, as shown by the dotted lines, to adapt the position of the light to suit the compositor. Small thumb screws at

the top of B and C, with suitable recesses in A, retain the light perfectly stationary in any position.
Each \$0 75

TYPE-HIGH GAUGE.

Much time may be saved in the press room if the maker-up will test all electrotypes, and have those that are high or low brought to the proper height by an electrotyper, or do it himself, before the form goes to press. The wise employer should insist on the use of this gauge.

Price, each. \$2 50

See Type-High Machines on page 539.

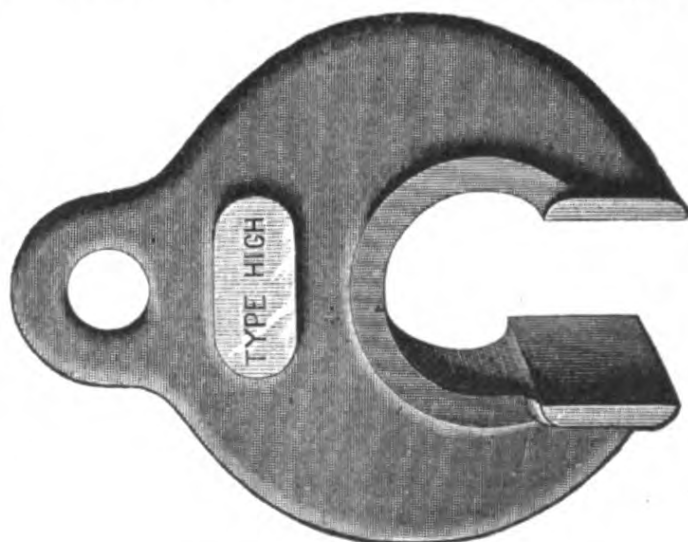

BRUCE TYPE FOUNDRY, 13 CHAMBERS STREET, NEW YORK.

EVERYTHING FOR THE PRINTER.

MITER BOXES.

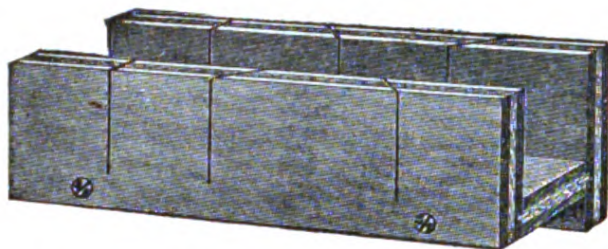

Our improved wood miter boxes are made of 3-ply glued stock, and will outlast the usual kind three to one. Will not break if thrown on the floor, and will resist all sorts of careless usage.

- Wood, 13½ ems wide, each \$0 50
- Wood, 3 inches wide, each 0 60
- IRON, each 2 50

BELLOWS.

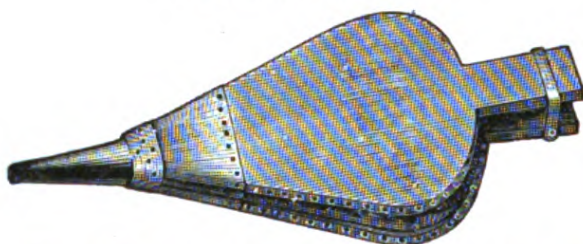

These bellows are correct in shape, and strongly made of the best materials.

- Small size \$1 00
- Large size 1 25

SAW.

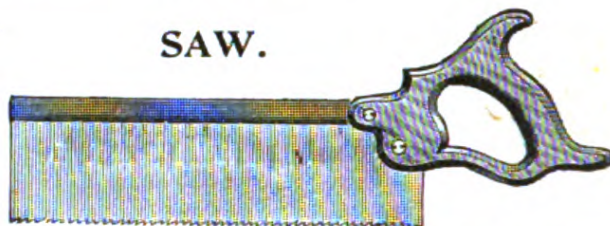

Back saw, for cutting wood or soft metal \$1 25

PRINTER'S DIVIDERS.

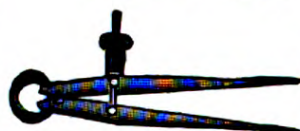

Always useful in laying out margins and distances, imposing plate forms, etc. A great time saver.

Price, each \$0 85

LEADER BOXES.

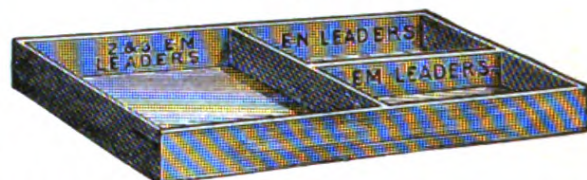

Just "the thing" for holding leaders. The size is 5×8×1¼ inches.

- Price, per dozen \$2 50
- Each 0 25

KEYSTONE HACK SAWS.

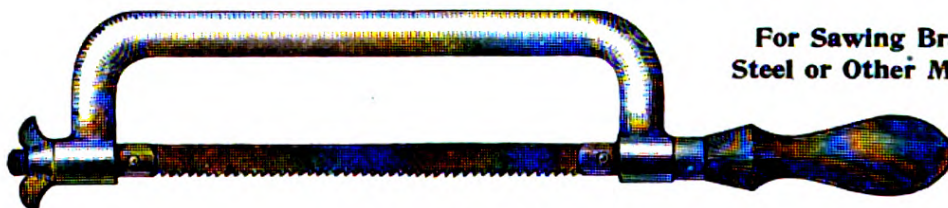

For Sawing Brass, Steel or Other Metals.

The saw blade is secured to the iron frame by two pins, and may be detached easily. When worn it is cheaper to put in a new blade than to refile. One dozen extra blades are furnished with each frame. This is a useful tool in any printing office for cutting thick brass rules, iron side sticks, etc.

- Eight-inch Keystone hack saw, polished frame, with one dozen saw blades \$1 50
- Extra blades, eight-inch, per dozen 1 00

SHOOTING STICKS.

- No. 3, wrought steel, nickel-plated, large, each \$0 75
- No. 2, wrought steel, nickel-plated, small, each 0 60
- Malleable iron, japanned, each 0 30
- Hickory shooting sticks, per dozen, 85 cents . . each, 0 08

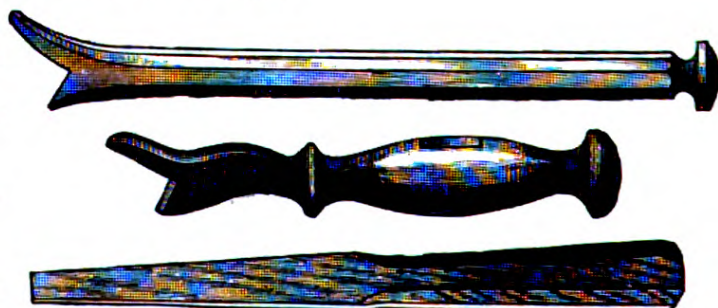

BRUCE TYPE FOUNDRY, 13 CHAMBERS STREET, NEW YORK.

EVERYTHING FOR THE PRINTER.

INK KNIVES.

- 6-inch blade, Style B . . . \$0 60
- 8-inch blade, Style B . . . 1 00
- 10-inch blade, Style B . . . 1 60

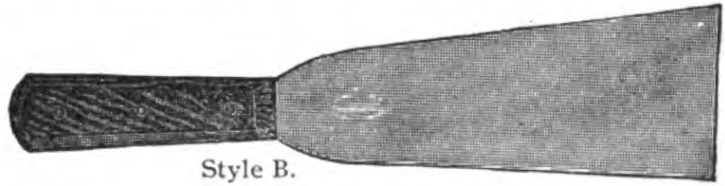

Style B.

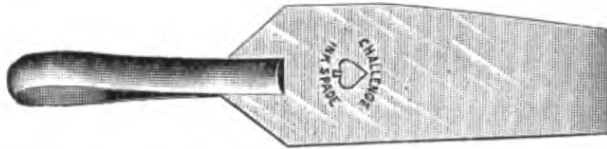

CHALLENGE INK SPADE.

It is all steel, full nickel plate, and will not discolor the daintiest tint.

- Steel handle, spring steel blade . . \$0 50
- By mail, 12 cents extra.

PAPER FOLDERS.



Also used for feeding cylinder presses.

- Steel, nickel-plated, 6 × 1 1/8 inches, each . . . \$0 50
- Bone, each, 25 cents; per dozen . . 2 50

PALLET INK KNIVES.



Square end.

- 6-inch blade . . . \$0 50
- 8-inch blade . . . 0 70
- 10-inch blade . . . 1 00

ST. JOHN PAPER KNIFE.

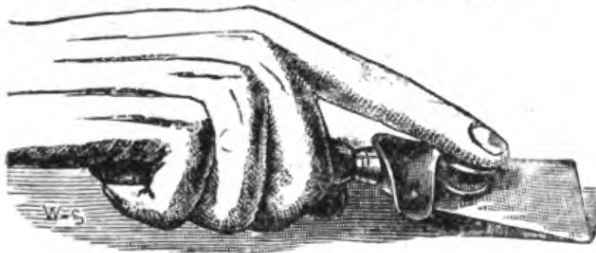

Made of fine steel and suitably pointed for cutting paper. Upon the back of the blade is fixed a broad guard, shaped to fit the finger, by which the operator is enabled to cut much faster and more easily than with a common knife.

- Price . . . \$0 50

INK SLICE.

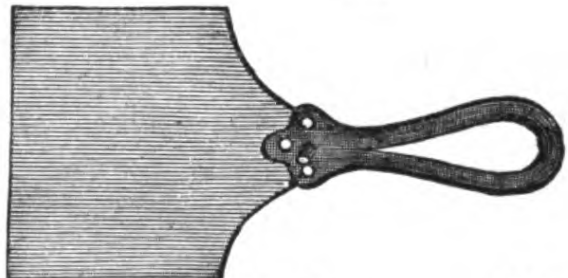

- Brass handle, steel blade . . . \$0 75

OVERLAY KNIFE.



- In leather case, 6 × 1/16 inch, nicked . \$0 60

ENGRAVERS' TOOLS.

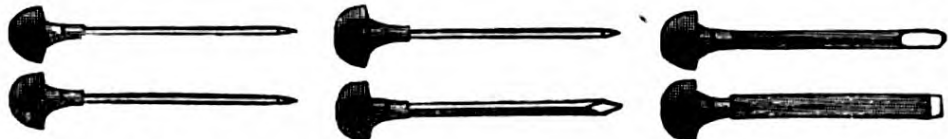

- Six tools, sharpened for use, with handles, in box . . . \$2 50

ENGRAVERS' WOOD.

Prepared to order, in the best manner. Prices are net. The minimum charge for Boxwood or Maple is twenty-five cents.

- Boxwood, per square inch . . . 2, 3, 4 and 5 cents.
- Maple, per square inch . . . 1 1/2 cents.
- Side-wood Poster Tint Blocks, 27 1/2 × 39 1/4 inches . . . \$1 25 each.
- Side-wood Poster Tint Blocks, per square foot . . . 0 25

MAGNIFYING AND REDUCING GLASSES.



Every careful printer needs these glasses. They are three inches in diameter, in strong metal frames with handle.

- Magnifying Glass, each . . . \$1 65
- Reducing Glass, each . . . 1 50

- STARS FOR FLY STICKS, per hundred . . . \$2 50

BRUCE TYPE FOUNDRY, 13 CHAMBERS STREET, NEW YORK.

EVERYTHING FOR THE PRINTER.

GAUGE PINS AND GUIDES.

See explanation of Nos. below.

Original Steel Gauge Pins, Nos. 1, 2, 3, 4, per dozen	\$0 60
Golden Steel Gauge Pins, Nos. 1, 2, 3, 4, 5, 6, per dozen	0 40
Spring Tongue Gauge Pins, one size only, per dozen	1 20
“ “ “ “ “ per set of three	0 40
Flexible Side Gauge Pins, per dozen	0 60
Perfect Register Gauge Pins, per set of three	1 25
Screw Adjusting Gauge Pins, one size only, per set of three	1 00
Extension Feed Guides, per pair	1 00
Cylinder Side Guides, each	0 50
Extra Tongues for Spring Tongue, “ Perfect,” or Screw Adjusting Pins, per dozen	0 25
Gauge Pin Drawers (see illustration at bottom of page), each	0 25

EXPLANATION OF NUMBERS.

No. 1 gauges are 12 points high, with lip $\frac{1}{16}$ -inch long; No. 2, 15 points high, $\frac{1}{16}$ -inch lip; No. 3, 18 points high, $\frac{1}{16}$ -inch lip; No. 4, 12 points high, short lip; No. 5, 15 points high, $\frac{1}{8}$ -inch lip; No. 6, 12 points high, $\frac{1}{4}$ -inch lip. All gauges with tongues are 12 points high.

GOLDEN STEEL GAUGE PIN.



ORIGINAL STEEL GAUGE PIN.



SPRING TONGUE GAUGE PIN.



This is the most satisfactory gauge pin made. It meets almost every requirement of the pressman.

FLEXIBLE SIDE GAUGE PIN.

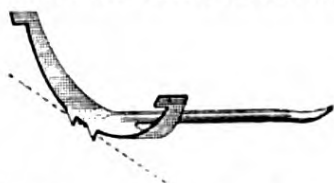

Non-smashable Gauge Pin.

May be placed directly under the gripper where it comes down upon the tympan. The sheets are fed to the curved spring arm. The pin is made of fine thin steel, and, having teeth, is adjustable and prevents the sheets from slipping under.

EXTENSION FEED GUIDES.

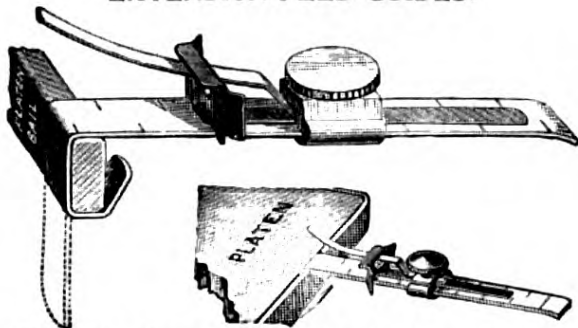

The cut shows the method of securing the guides between platen and platen bail, so that sheets may be fed below the lower edge of the platen.

PERFECT REGISTER GAUGE PIN.

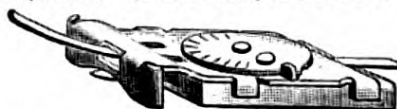

Pastes on like a quad, has a thin steel clip which strikes into tympan and prevents sheets from slipping under gauges, and is adjustable after pasting on.

SCREW ADJUSTING GAUGE PIN.

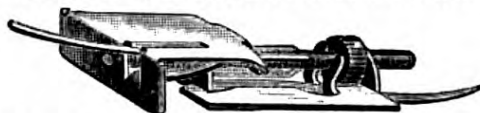

The prong should be inserted a quarter inch below the feeding line and forced snugly home. The base may be secured to the tympan with paste or glue if desired. The adjustment is got by means of the screw and nut with absolute precision and without weakening the hold of the pin to tympan.

CYLINDER SIDE GUIDE.



Secured to feed-board by the sharp point shown in outline in cut, which is placed at the side of pillar, so that hair adjustments may be got by simply turning the pillar to the desired position. The bendable brass tongue is adjustable in every direction.

GAUGE PIN DRAWER.

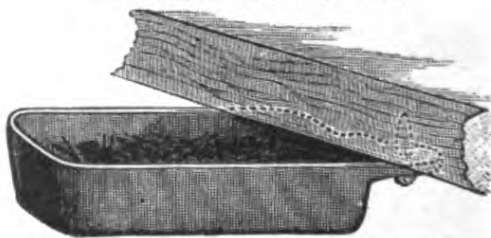

Screws on under the feed-board.

EVERYTHING FOR THE PRINTER.

PRESS POINTS.

For inserting in wood furniture when sheets are printed for folding machine. Points are screwed into wood with wrench as far as the cross pin will allow, when they will be found to be correct height.



Points, per dozen \$0 75
Wrench 0 75

DILLINGHAM PRESS PUNCH.

Patented March 2, 1897.

Is secured to the tympan of platen presses in same manner as a feed guide, and punches a clean hole in card or paper simultaneously with the printing on jobs which have a margin of one inch or more. The method of working this punch is clearly shown in accompanying half-tone. The slightly curved spring is placed under the upper tympan sheet, and the sheet to be punched is fed over this curved

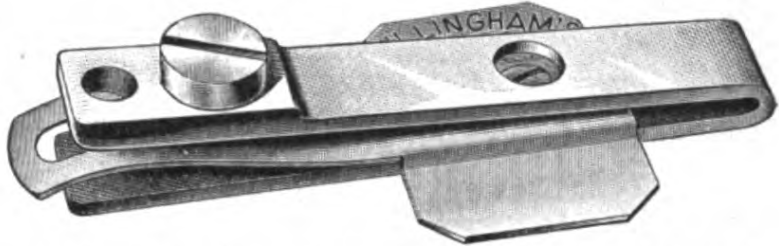

spring and under the punch with no more trouble than in feeding to gauge pins. The punch is secured to the tympan by paste or glue or (better still) by a mixture of paste and glue. Two or more punches can be used on one sheet. Punching and printing can be done simultaneously on a variety of work, such as window cards, programmes, orders of dance, souvenirs, etc.

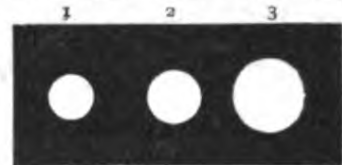
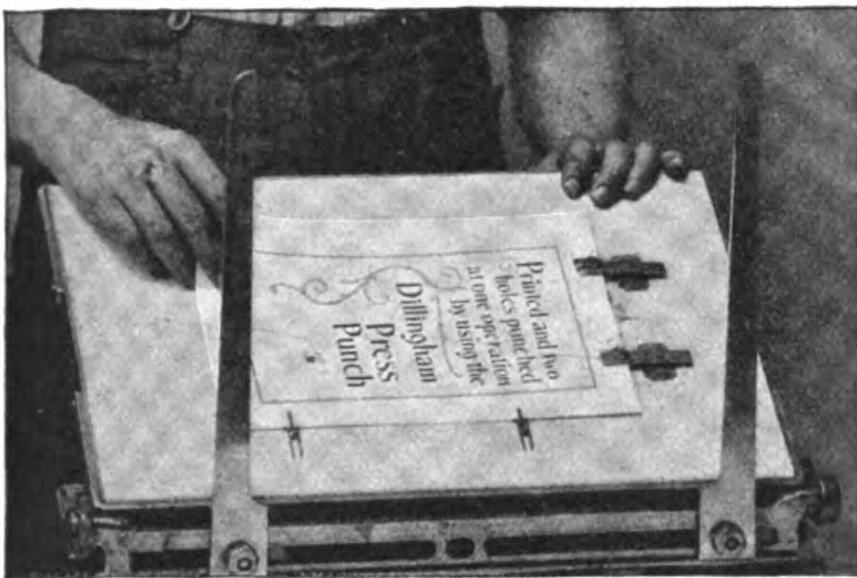

Made with three size holes, Nos. 1, 2 and 3, as per diagram. No. 3 will be sent unless otherwise ordered.

Each, with directions, net \$1 25

ELM CITY PRESS PUNCH.

One or more may be locked in a type form and will cut a clean, round hole $\frac{1}{8}$, $\frac{3}{16}$ or $\frac{1}{4}$ inch in paper or card stock at the same time the job is printed. This punch will not clog, as each piece cut is automatically ejected by the plunger as soon as the impression is released and falls on the floor. The ejector also protects the rollers from any danger of injury from the cutter. The punches are made on 30 and 36 point bodies. All parts being interchangeable, new cutters can be readily fitted in case of accident. The spring for controlling the ejector can also be made stronger by turning screw at bottom. The cutters are made two points lower than type to allow for pasting a small square of cutting fibre, which is furnished with the punches, on the tympan.

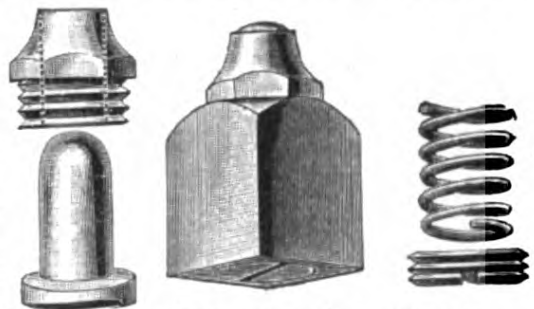

Per set for cutting $\frac{1}{8}$, $\frac{3}{16}$ and $\frac{1}{4}$ in. holes \$1 50
One punch, any size 0 75

Extra cutters, made of finest tool steel, \$0 15
Cutting fibres, per doz 0 10

PRESS PUNCH.

This punch is about one thirty-second inch lower than type, and can be locked up in a type form, thus enabling printers to punch holes in stock at the same time it is printed, without extra expense. A piece of 2-point brass rule should be cemented to the tympan sheet for the punch to strike on, and an opening left in the form opposite opening in base of punch to prevent it from becoming clogged. Made of best tool steel, tempered.

For $\frac{1}{8}$, $\frac{3}{16}$, or $\frac{1}{4}$ inch hole, each \$1 00



BRUCE TYPE FOUNDRY, 13 CHAMBERS STREET, NEW YORK.

EVERYTHING FOR THE PRINTER.

HEMPEL IMPROVED QUOIN.

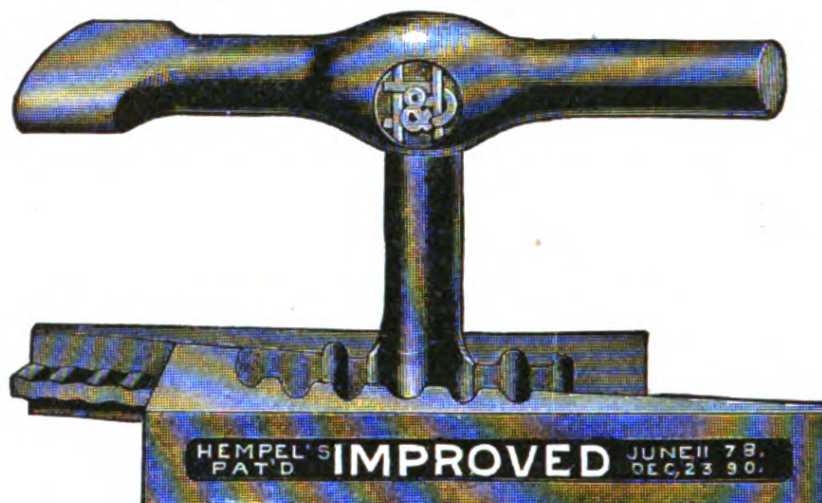

The Hempel Quoins are the standard, tested by time and approved by those who use them. This is the latest improved quoin.

No. 1 small, per dozen pairs	\$2 50
No. 2, large, per dozen pairs	3 00
Keys, each	0 50

IMPROVED BROWER QUOIN.

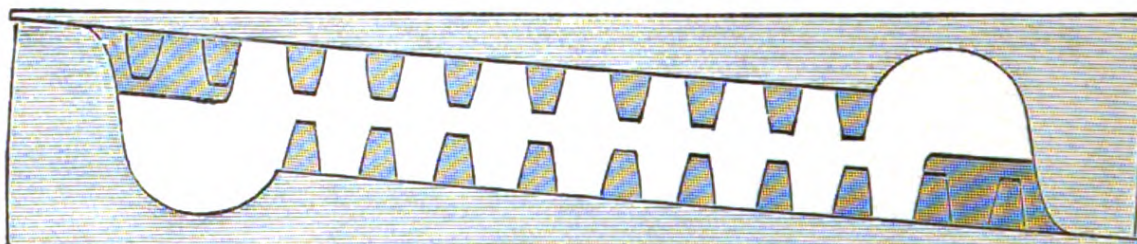

No. 2 Brower Quoin, actual size.

Has central racks, and consequently will not throw type off its feet. Works smoothly. The key, of steel, with cut teeth, has a firmer and deeper hold than in the old style quoin.



No. O. "Little Samson," actual size.

The No. O, as illustrated, is the smallest wedge quoin ever made, and will prove very valuable for job printers and on occasions when lock-up must be made in small spaces.

No. O, smallest wedge quoin made, "Little Samson," per dozen	\$2 00
No. 1, medium size, per dozen	2 50
No. 2, large size, per dozen	3 00
Steel keys, all sizes, each	0 50

	Per Dozen.	Key.
WICKERSHAM QUOIN	\$2 50	\$0 50
PERRY QUOIN	2 50	0 50
CHALLENGE HEMPEL QUOIN, No. 1	2 50	0 50
CHALLENGE HEMPEL QUOIN, No. 2	3 00	0 50

BRUCE TYPE FOUNDRY, 13 CHAMBERS STREET, NEW YORK.

EVERYTHING FOR THE PRINTER.

UNION LOCKABLE QUOIN.

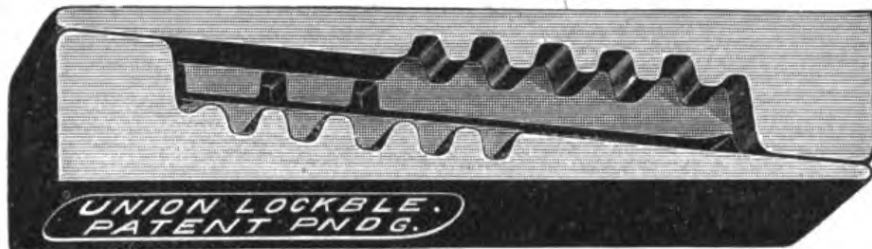

An exact duplicate of the original Hempel Quoin, with three notches cut in the central rib for the purpose of using the quoin in connection with the Patent Brower Lock, listed below.

No. 1, small, per dozen \$2 50 | No. 2, large, per dozen \$3 00
 Keys, each \$0 50

BROWER QUOIN LOCK.

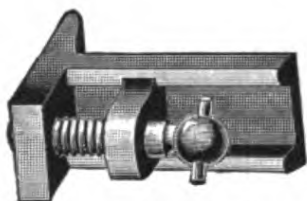

Fig. 2. The Lock.

The sidewise projection shown in Fig. 2 engages in notches cut in central rib of Union Lockable Quoin, or in the rack teeth of the Brower Quoin (see opposite page). The screw is then set up against the other half of the quoin, effectually preventing it from slipping. Quoins of the wedge principle are all liable on long runs to be loosened by the vibrations of the press. These locks make the lock-up doubly sure. They should be applied by the pressman after he has completed the make-ready and before the run is commenced.

No. 0, to fit No. 0 Brower Quoin, per dozen \$2 50
 No. 1, to fit No. 1 Brower Quoin, per dozen 2 75
 No. 2, to fit No. 2 Brower Quoin, per dozen 3 00
 No. 3, to fit No. 1 Union Lockable Quoin, per dozen 2 75
 No. 4, to fit No. 2 Union Lockable Quoin, per dozen 3 00
 Screw-driver, to fasten Quoin Lock, each 50

MIDGET SAFETY QUOIN.

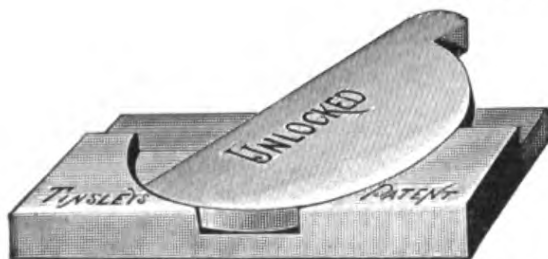

Fig. 3. Shows Midget Quoin unlocked.

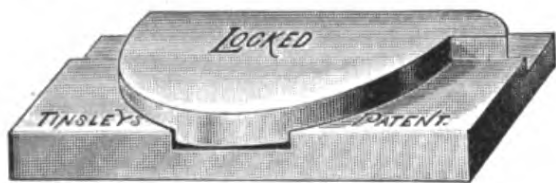

Fig. 2. This cut shows extreme expansion of six points when locked.

It is locked by a tap of a mallet, and occupies no more space in length when locked than when unlocked.

Can be used in a space 18 points wide by 120 points long, either outside or inside a form. It is absolutely safe, as when locked it rests against its corresponding flat surfaces, and the harder the surface it bears against the better.

This invaluable quoin may be used to lock up matter inside a brass circle, or oval, or within a solid border, or in places where no other quoin of wood or metal can be used.

Fig. 1 illustrates how this quoin is used in a mortised cut.

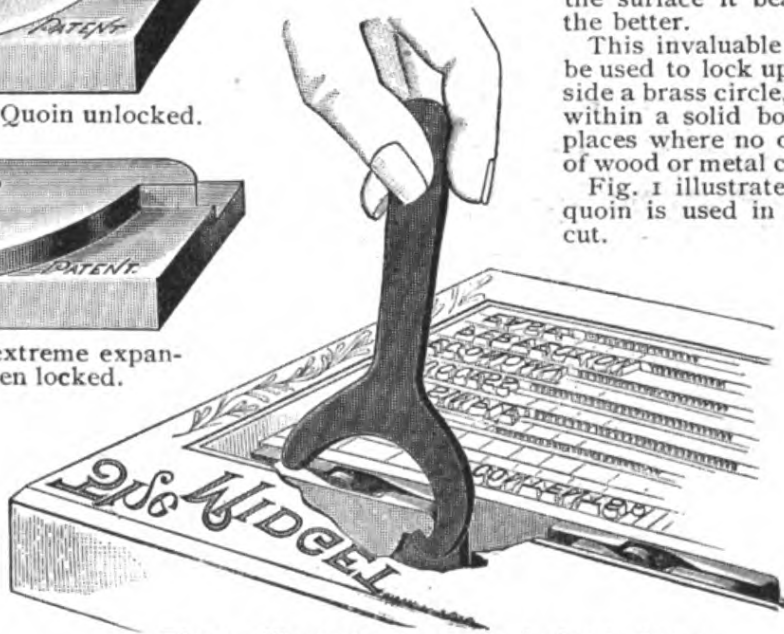

Fig. 1. Illustrates the method of unlocking.

Price, per dozen, with key, net \$2 00

BRUCE TYPE FOUNDRY, 13 CHAMBERS STREET, NEW YORK.

EVERYTHING FOR THE PRINTER.

THE MORTON LOCK-UP.

Rigid. Direct Spread. Quick. Secure.



An iron side-stick with broad bearings, true and square, attached to the best machine-

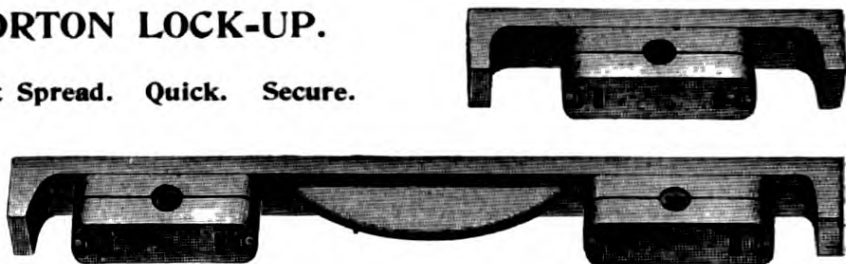

finished steel quoins. The quickest, safest and most complete lock-up—all in one piece. Place directly against type, putting furniture (if required) between chase and quoins. Give key a half-turn, and—that is all. No skew or spring; no waste of time or patience; and *no quoin can drop out* through carelessness, if any one has sufficient bearing.

The Morton Lock-Ups vary from exact inch measurement to agree (practically) with point lengths.

PRICES.

	Each.
3½-in., 1 quoin . . .	\$0 40
4-inch, 1 quoin . . .	0 40
5-inch, 1 quoin . . .	0 40
6-inch, 1 quoin . . .	0 45
6-inch, 2 quoins . . .	0 70
7-inch, 2 quoins . . .	0 70
8-inch, 2 quoins . . .	0 75
9-inch, 2 quoins . . .	0 75
10-inch, 2 quoins . . .	0 80
12-inch, 3 quoins . . .	1 10
13-inch, 3 quoins . . .	1 15
15-inch, 3 quoins . . .	1 20
18-inch, 3 quoins . . .	1 30

KEYS.

	Each.
Plain	\$0 50
Polished	0 75

Newspaper side-sticks and special lengths to order.

THE WICKERSHAM QUOIN.

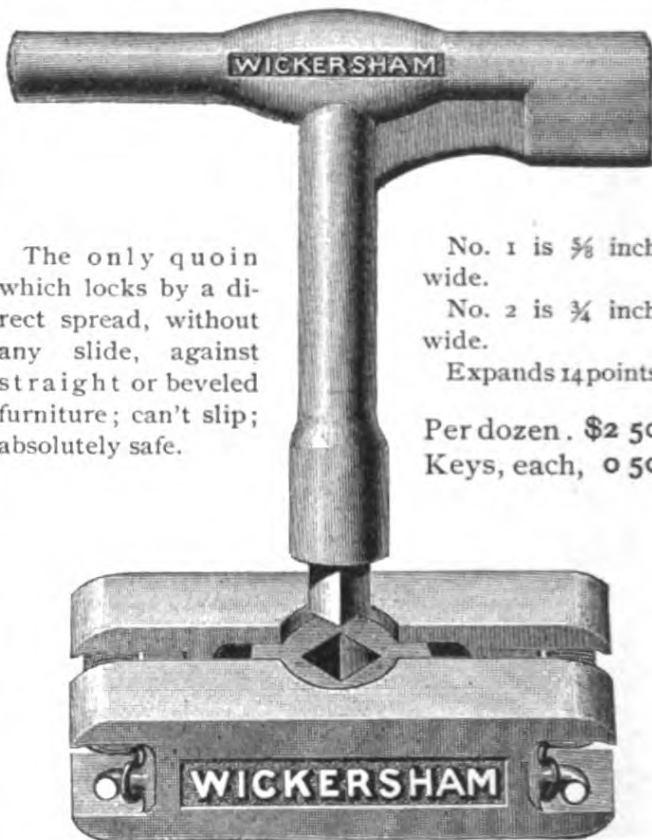

The only quoin which locks by a direct spread, without any slide, against straight or beveled furniture; can't slip; absolutely safe.

No. 1 is 5/8 inch wide.
No. 2 is 3/4 inch wide.
Expands 14 points
Per dozen. \$2 50
Keys, each, 0 50

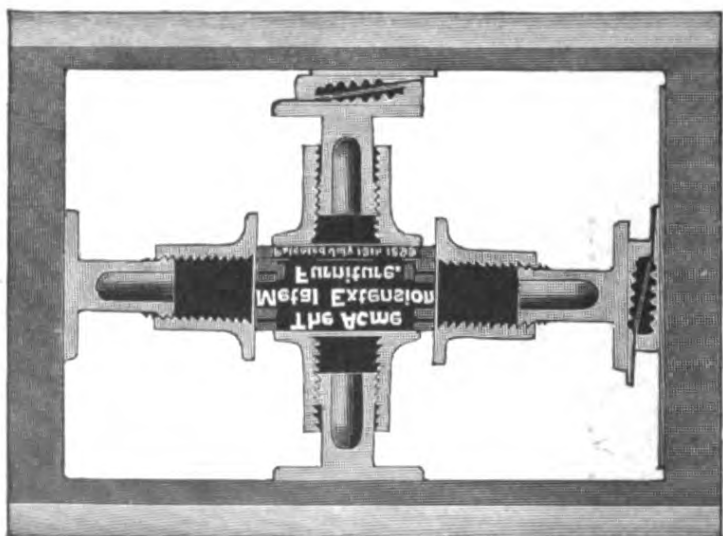

ACME METAL EXTENSION FURNITURE.

Designed to save time in locking up forms for job presses. It is quickly handled, and is adjustable according to Picas, extending from two and one-quarter to four inches. When locked up it is perfectly secure.

Price, per set of four . . . \$1 50
Per dozen (three sets) . . . 4 00

EVERYTHING FOR THE PRINTER.

NEVER-SLIP QUOIN.

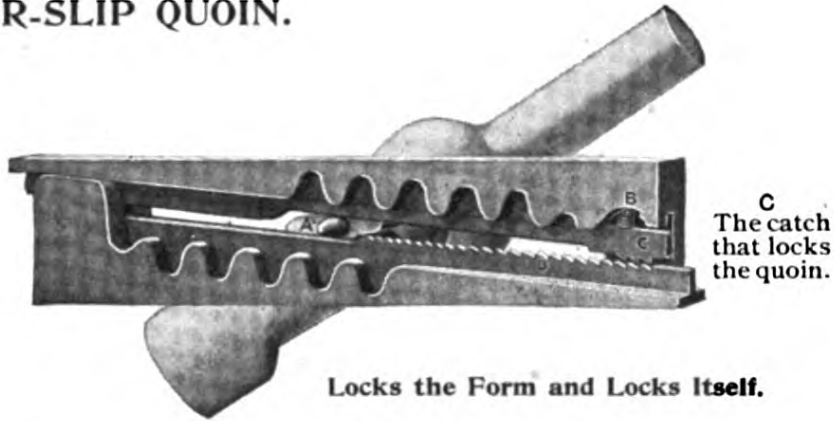

This quoin possesses all the advantages of any other quoin made. It is impossible for this quoin to slip after the form is locked up with it. This alone makes it of great value on fine work where exact register is required.

The Never-Slip Quoin is adapted to any ordinary work. It saves time, saves the imposing stones and the bed of the press. There is no possible chance of it becoming unlocked on the press. The simplicity of this quoin is its strongest feature. It is handled with a key like the ordinary quoin.

Price, per dozen \$3 25
 Keys, each 75

PRINTERS' TRUCKS.

Lay Printed Sheets on Trucks and not on the Floor, and thus Save Cost and Loss in Handling.

With platform 34 inches wide by 50 inches long, 11 3/4 inches high \$16 00

Special prices in quantities. Other sizes at proportionate rates.

Made of hard wood 1 1/4 inches thick, bolted, varnished. Center wheels, 9 3/4 inches diameter, 3 inches face. Caster wheels, 4 3/4 inches diameter, 1 1/4 inches face. Steel axle, 1 1/4 inches square, with steel braces 1 1/4 x 1/4 inches. The T-shaped handle is of 7/8-inch round steel, and is quickly attached to or detached from two eyelets fixed at each end. Weight, 182 pounds; handle weighs 11 1/2 pounds.

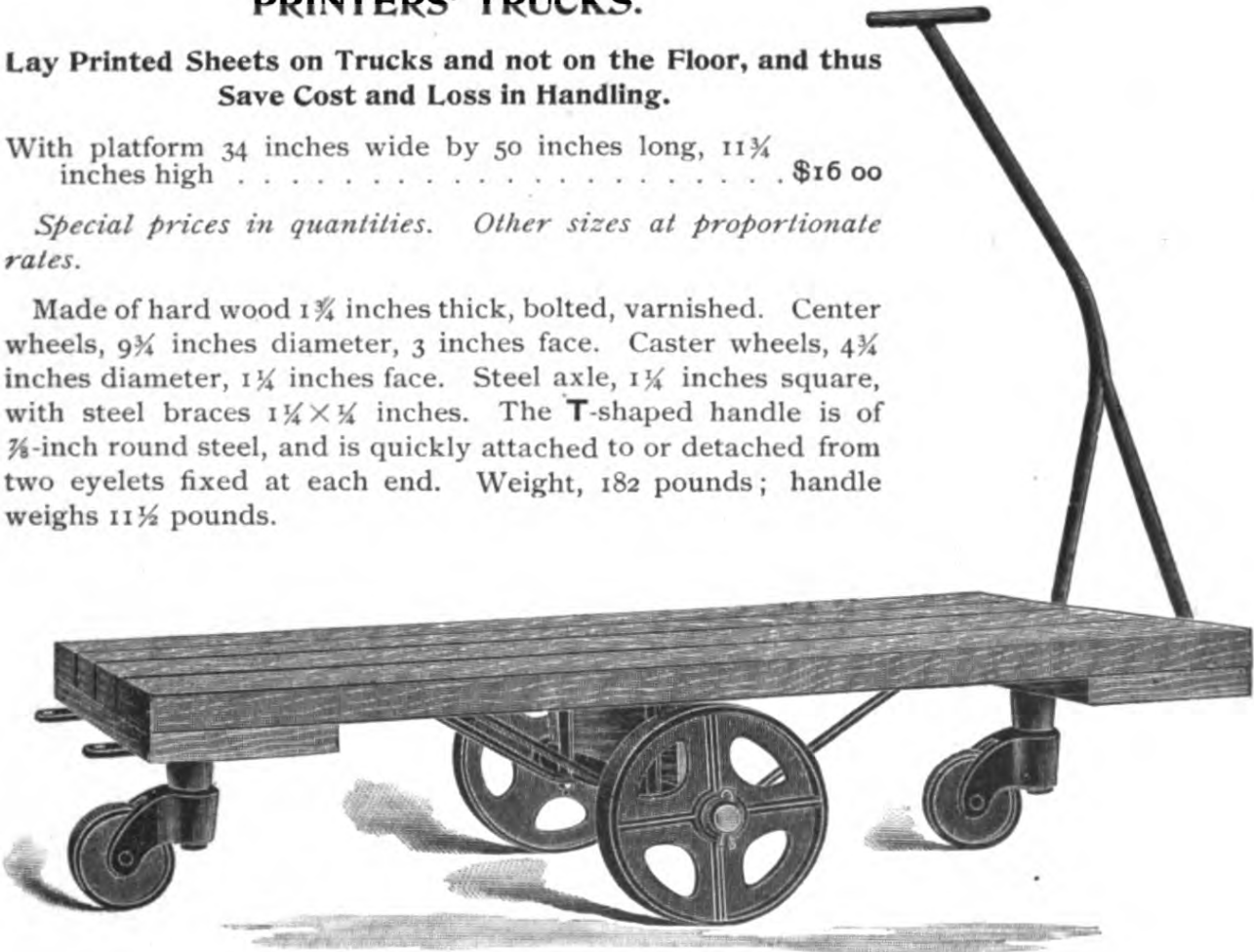

BRUCE TYPE FOUNDRY, 13 CHAMBERS STREET, NEW YORK.

EVERYTHING FOR THE PRINTER.

MILLER PERFECT GRIPPER PERFORATOR.

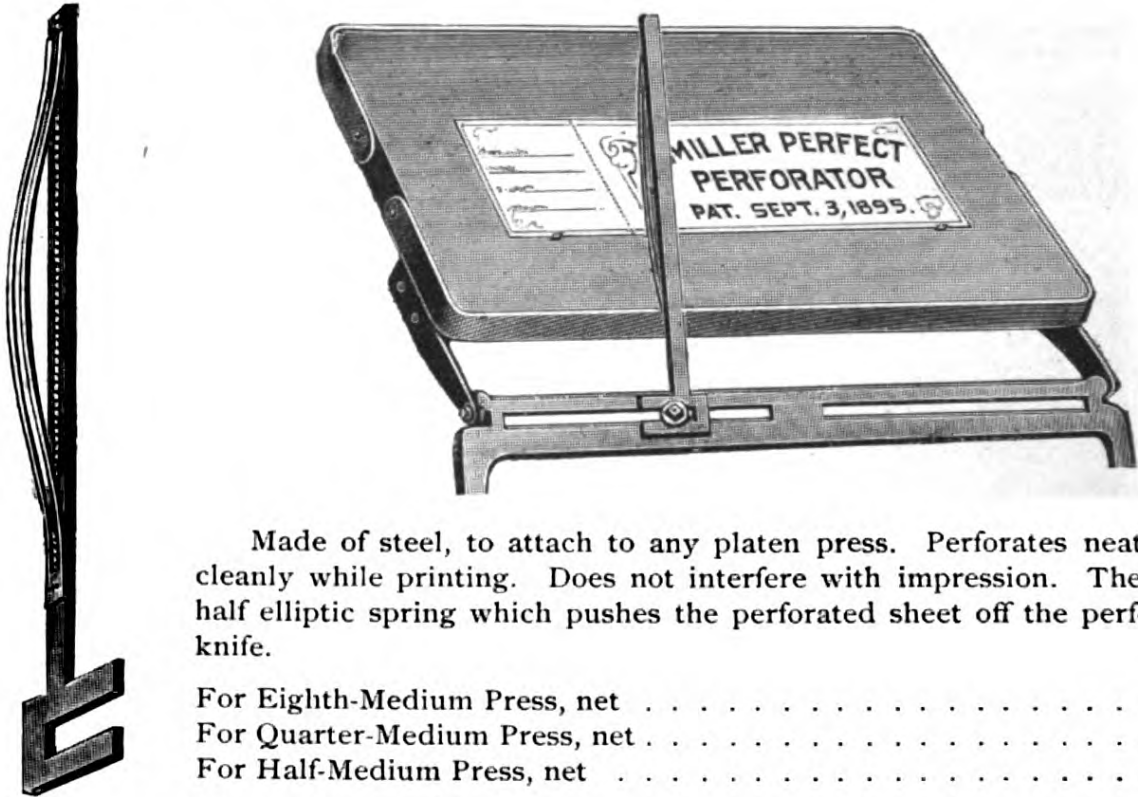

Made of steel, to attach to any platen press. Perforates neatly and cleanly while printing. Does not interfere with impression. There is a half elliptic spring which pushes the perforated sheet off the perforating knife.

- For Eighth-Medium Press, net \$5 00
- For Quarter-Medium Press, net 6 00
- For Half-Medium Press, net 7 00

When ordering it is necessary to state name and size of press.

PERFORATING AND SCORING MACHINE.

This Perforator and Scorer consists of a depressible, or disappearing, interchangeable steel blade (either with perforating or scoring surface), acting in connection with a base plate and lever, all secured within a steel casing and operated by a rubber pressure quad glued to the tympan, which presses against the lever, bringing blade into position just before taking impression.

It locks into the form and saves time, rollers and money by perforating (or scoring) and printing at one impression.

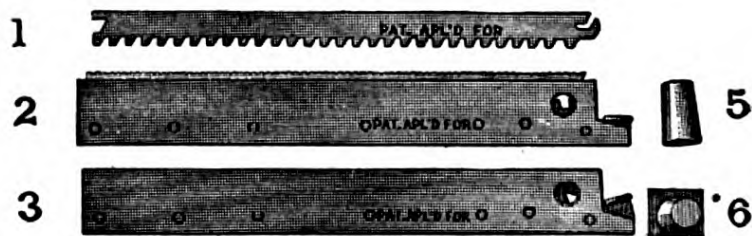

- 1—Creasing Blade.
- 2—Perforating Blade in position to take impression.
- 3—Perforator with Blade depressed.
- 5—Pressure Quad.
- 6—Pressure Quad glued on cardboard.

Made in the following sizes :

Sizes.	Total length.	Perforates or Scores.	Price.
No. 1	5 inches	4 1/8 inches	\$3 00
No. 2	7 inches	6 1/8 inches	4 00
No. 3	10 inches	9 inches	5 00
No. 4	12 inches	11 inches	6 00

BRUCE TYPE FOUNDRY, 13 CHAMBERS STREET, NEW YORK.

EVERYTHING FOR THE PRINTER.

UNION STORAGE CAN.

For Holding Benzine or Oils.

It is strongly made of galvanized iron and is self-closing. There can be no evaporation, and no fluid can be spilled until the nozzle is opened by means of the spring. A very necessary article in all printing offices which are permitted to have one or more gallons of benzine on the premises.

Quite a saving in the cost of benzine and oils will be realized by purchasing in the quantities held by these storage cans, besides avoiding the inconvenience of sending out at frequent intervals to get the ordinary benzine can filled up.

- 1-gallon can \$2 00
- 3-gallon can 2 50
- 5-gallon can 3 00



UNION SAFE BENZINE CAN.

This is patterned after the original benzine can, with the addition of a circular plate around the head, near the vent, by means of which the valve is opened without wetting the fingers. When pressure is removed it closes automatically. The head is attached to the can with a chain, so that it cannot be lost when unscrewed for the purpose of filling with benzine.



Made of tin.
Enamelled red.

Holds one quart, each \$0 75

SUCCESS SAFETY BENZINE CAN.

Made of Brass.

By the use of this safety can leakage of benzine or its vapor is prevented, as the stopper is automatically self-locking — always tightly closed when the can is not in use. The flow of benzine, naphtha or any other fluid is regulated by the pressure of the second and third fingers upon a circular plate on the nozzle; and the adjustment is so perfect that one can pour a single drop, or a full stream, at will. It is also neat and cleanly, for the hands are kept entirely free from contact with its contents. The patent improved stopper is as durable as it is simple. Made of the best material, and carefully finished and adjusted.

As a safeguard against loss by fire, this can is an economical and profitable "policy." Benzine is dangerous, but its use is divested of risk where this improved can is employed. It has been put to the test, and proved safe and serviceable in every respect. It may be overturned or placed in any position whatever, and the contents will not spill or overflow. There are no chains or exposed springs.

Approved by the Board of Fire Underwriters.



- Quart can \$0 75
- Gallon can 2 00

BRUCE TYPE FOUNDRY, 13 CHAMBERS STREET, NEW YORK.

EVERYTHING FOR THE PRINTER.

FELT BLANKETS.

Width.	Thick, Per Yard.	Thin, Per Yard.	Width.	Thick, Per Yard.
36 inches	\$5 40	\$2 75	56 inches	\$8 50
40 inches	6 00	3 00	58 inches	8 75
44 inches	6 60	3 25	60 inches	9 00
48 inches	7 25	..	62 inches	9 50
54 inches	8 10	..	65 inches	9 75

FELT BLANKETS.

Size Bed.	Size Blanket.	Thick, Each.	Thin, Each.
17×21	19×20	\$2 75	\$1 75
20×25	23×24	3 25	2 00
21×27	25×25	3 50	2 25
24×30	28×28	4 00	2 75
25×35	29×33	5 50	3 75
29×42	34×40	6 25	5 00
32×46	38×44	8 75	6 50
33×50	38×47	9 75	7 50
36×52	42×49	11 25	9 25
40×54	46×53	12 25	10 00

RUBBER BLANKETS.

Size Bed.	Size Blanket.	Regular Thickness.
17×21	19×20	Each, \$3 00
20×25	23×24	Each, 4 25
21×27	25×25	Each, 4 75
24×30	28×28	Each, 5 75
25×35	29×33	Each, 6 50
29×42	31×40	Each, 8 75
32×46	28×44	Each, 10 50
33×50	38×47	Each, 11 75
36×52	42×49	Each, 13 25
40×54	46×53	Each, 17 00

FELT BLANKETS FOR HAND PRESSES.

For 6-column Newspaper	\$3 00	For 8-column Newspaper	\$5 00
For 7-column Newspaper	3 75	For 9-column Newspaper	6 50

ROLLER CLOTH.

In rolls 12 yds. long by 2½ in. wide, per roll \$5 00

RUBBER BLANKETS.

	2-Ply 1-16-Inch Thick.	3-Ply 1-12-Inch Thick.	5-Ply ¾-Inch Thick.	Tympan Rubber.
26 inches wide, per yard	\$5 00	\$6 25	\$7 25	..
32 inches wide, per yard	5 75	7 00	8 75	..
34 inches wide, per yard	6 25	7 50	9 75	..
36 inches wide, per yard	6 50	7 75	10 25	\$1 25
38 inches wide, per yard	7 25	8 50	11 25	..
40 inches wide, per yard	7 50	8 75	11 75	..
44 inches wide, per yard	8 50	10 00	13 50	..
48 inches wide, per yard	10 50	12 00	16 00	..

TYMPAN PRESSBOARDS.

21×29 inches, each	\$0 50	35×52 inches, each	\$1 25
26×35 inches, each	0 75	40×56 inches, each	1 50
29×42 inches, each	1 00		

TAPE.

¾-inch, per roll	\$0 75	1-inch, per roll	\$1 50
⅝-inch, per roll	0 75	1½-inches, per roll	1 60
⅜-inch, per roll	1 00	1¾-inches, per roll	1 75
¼-inch, per roll	1 25	1½-inches, per roll	2 00
⅙-inch, per roll	1 40		

A roll of tape contains thirty-six yards.

TAPE FASTENER.

Fastens tape with eyelets, which are neatly clinched by the fastener.

Price, with box of eyelets \$1 25

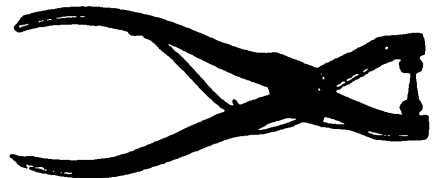

BRUCE TYPE FOUNDRY, 13 CHAMBERS STREET, NEW YORK.

EVERYTHING FOR THE PRINTER.

METALLIC TAPE COUPLERS.

This is a device for connecting ends of tape on presses and folding machines, so that there will be no wear at the joined parts, as is usual on sewed ends, which wear and cause the tape to run crooked and throw paper out of register. The Metallic Tape Coupler outlasts other methods of securing the ends of tape, and keeps the tape running true. It can be put on in a few seconds by means of parallel pliers made for that purpose.

PRICE PER BOX OF FIFTY.

No. 1, for ½-inch tape	\$1 25
No. 2, for ⅝-inch tape	1 50
No. 3, for ¾-inch tape	1 50
No. 4, for ⅞-inch tape	1 75
No. 5, for 1-inch tape	1 75
No. 6, for 1 ⅛-inch tape	1 75

SMOOTH-JAW PARALLEL PLIERS.

These pliers can be used for all sizes of couplers, per pair 1 00

PRINTERS' BRUSHES.

SOLID-BACK LYE BRUSH.

	Per doz.	Each.
No. 20. Medium, all bristle	\$5 00	\$0 50
No. 30. Large, all bristle	7 00	0 75
No. 8. Medium, Tampico	3 50	0 40
No. 9. Large, Tampico	4 50	0 50

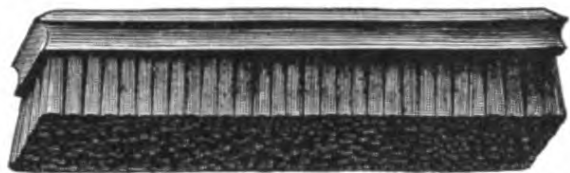

Furnished with handle at same price, if desired.



BENZINE BRUSH, OVAL BACK.

Benzine Brush, all bristle, oval back, genuine "pick" brush \$0 60

BENZINE BRUSH, WITH HANDLE.

Benzine Brush, all bristle \$0 40

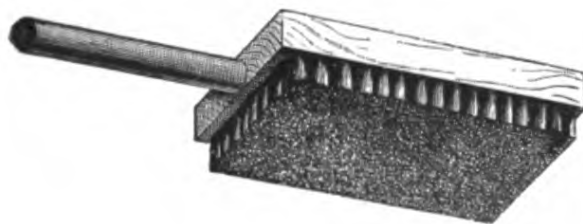

STEREOTYPE BEATING BRUSHES.

No. 120	\$5 00
No. 121	6 00
No. 122	7 00

LIQUID CEMENT BRUSH.

Made of French bristles, flat and double thick.

1 inch	\$0 30
1 ½ inch	0 40
2 inch	0 55
3 ½ inch	0 75

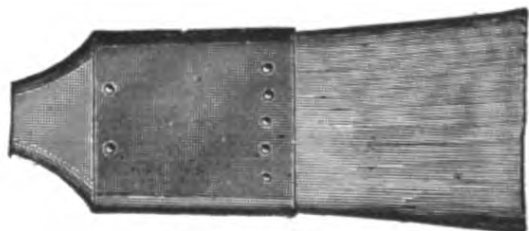

BRUCE TYPE FOUNDRY, 13 CHAMBERS STREET, NEW YORK.

EVERYTHING FOR THE PRINTER.

SMOOTH-LINED BRASS GALLEYS.

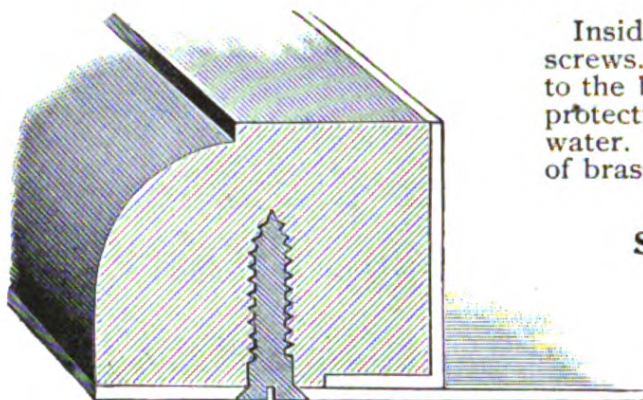

Sectional end view, showing how the brass lining protects the wood rim from action of lye and water.

Inside they are perfectly smooth and free from screws. The lining is angle brass, and is soldered to the bottom plate, strengthening the sides, and protecting the wood rim from the action of lye and water. The head is supported by a strong strip of brass.

SMOOTH-LINED JOB GALLEYS.

6	× 10 inches inside	\$2 00
8 ³ / ₄	× 13 inches inside	2 50
10	× 16 inches inside	3 00
12	× 18 inches inside	3 50
14	× 20 inches inside	4 00
15	× 22 inches inside	5 00
18	× 25 inches inside	5 75

SMOOTH-LINED COLUMN GALLEYS.

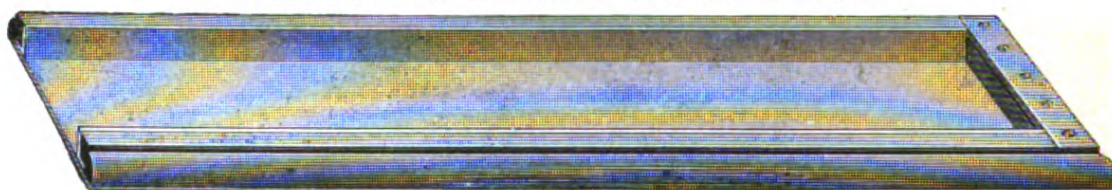

Smooth-Lined Column Galley, showing Brass Plate at Head.

Single Column, brass-lined,	3 ¹ / ₂ × 23 ¹ / ₈ inches inside	\$2 00
Single Column, brass-lined,	3 ¹ / ₂ × 11 ³ / ₈ inches inside	1 50
Medium width, brass-lined,	4 ³ / ₄ × 23 ¹ / ₈ inches inside	2 25
Double Column, brass-lined,	6 ¹ / ₄ × 23 ¹ / ₈ inches inside	2 50
Triple Column, brass-lined,	8 ¹ / ₂ × 23 ¹ / ₈ inches inside	3 00
Single Column, half-lined,	3 ¹ / ₂ × 23 ¹ / ₈ inches inside	1 75
Double Column, half-lined,	6 ¹ / ₄ × 23 ¹ / ₈ inches inside	2 25

UNLINED GALLEYS.

ZINC BOTTOM.

Single Column, 3 ¹ / ₂ × 23 ¹ / ₈ inches inside	\$1 25
Double Column, 6 ¹ / ₄ × 23 ¹ / ₈ inches inside	1 50

BRASS BOTTOM.

Single Column, 3 ¹ / ₂ × 23 ¹ / ₈ inches inside	\$1 50
Double Column, 6 ¹ / ₄ × 23 ¹ / ₈ inches inside	2 00

CLOSED-END MAILING GALLEYS.



6 ¹ / ₄ × 23 ¹ / ₈ inches inside, closed ends, all brass, each	\$3 25
7 ¹ / ₄ × 23 ¹ / ₈ inches inside, closed ends, all brass, each	3 50
6 ¹ / ₄ × 22 ¹ / ₄ inches inside, closed ends, brass lined, each	3 00
10 × 22 ¹ / ₄ inches inside, closed ends, brass lined, each	4 00
2 ⁷ / ₈ × 24 inches inside, closed ends, brass lined, each	2 25
6 ¹ / ₄ × 22 ¹ / ₄ closed ends, zinc bottom, unlined, each	1 50

EVERYTHING FOR THE PRINTER.

SUCCESS RIVETED ALL-BRASS GALLEYS.

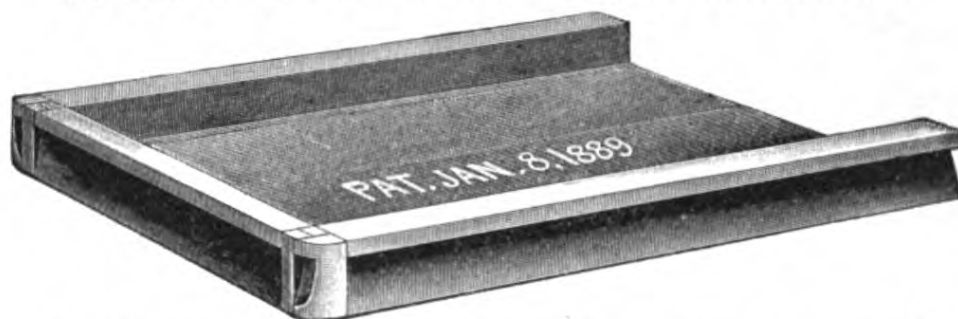

Made of heavy brass, the sides *riveted* strongly to the bottoms, and the corners locked together by a patented hold, which effectually resists all the strain of locking-up. These galleys will be found to be a great improvement over those galleys with bottoms screwed to the sides. The list prices remain the same as charged for



Shows method of securing sides to bottom by rivets.

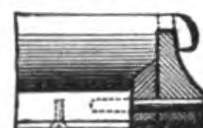

Shows patent corner hold.

galleys with bottom secured by screws. These galleys have been the standard for quality and construction for several years, and are still unexcelled.

ALL-BRASS COLUMN GALLEYS.

Single, 3¼ × 23¼ inches inside . . . \$2 00	Double, 6¼ × 23¼ inches inside . . . \$2 50
Single, 3¼ × 11¼ inches inside . . . 1 50	Triple, 8¼ × 23¼ inches inside . . . 3 25
Medium, 5 × 23¼ inches inside . . . 2 25	

ALL-BRASS JOB GALLEYS.

6 × 10 inches inside \$1 50	12 × 18 inches inside \$3 75
8¼ × 13 inches inside 2 00	14 × 21 inches inside 4 50
9 × 14 inches inside 2 50	15 × 22 inches inside 5 00
10 × 16 inches inside 3 00	18 × 25 inches inside 6 00

MAILING GALLEYS.



Mustang Mailing Galley.

Mustang Mailing Galley, zinc bottom \$0 50
Mustang Mailing Galley, brass bottom 0 75

WOODEN GALLEYS.

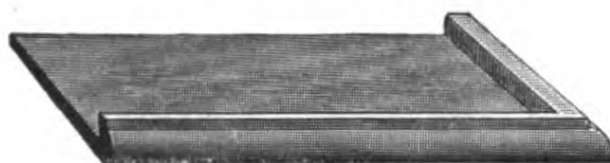

5 × 8 inches inside \$0 25
5 × 15 inches inside 0 30
5½ × 18 inches inside 0 40
6 × 10 inches inside 0 30
6½ × 24 inches inside 0 60
7 × 22 inches inside 0 55
8 × 10 inches inside 0 40
8 × 24 inches inside 0 60
10 × 16 inches inside 0 65
9 × 18 inches inside 0 70
10 × 24 inches inside 0 75
3½ × 24 inches inside 0 50

BRUCE TYPE FOUNDRY, 13 CHAMBERS STREET, NEW YORK.

EVERYTHING FOR THE PRINTER.

LINCOLN ALL-BRASS GALLEYS.

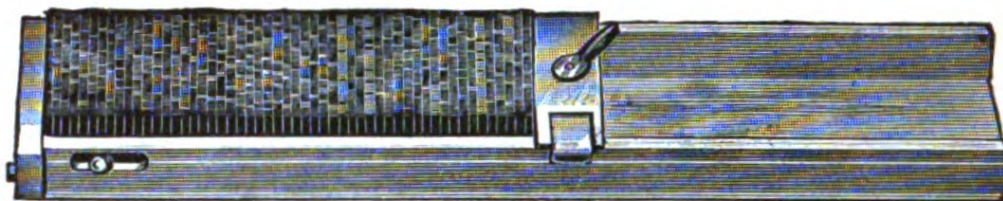

Shows the Galley locked at end and side.

A good galley for newspaper work. *Made to order* to hold any regular widths of matter in regular use in an office. The upper side or rim of galley is strongly hinged to the bottom.

This hinged side is dropped when emptying on galley, and when matter is ready for locking up the side is raised and is held by a spring-catch at head of galley

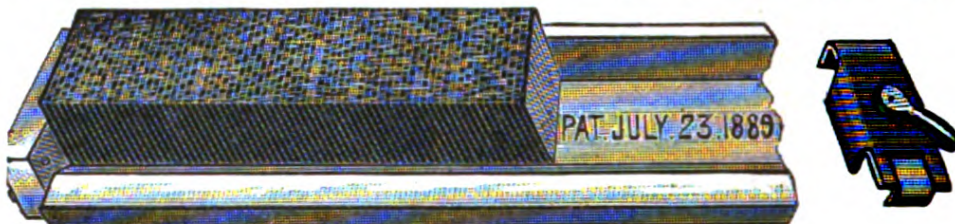

Shows the Galley unlocked, with end lock detached.

and by the end clamp which locks the sides and end at the same operation. The catch is loosened by turning lever to the right. These galleys are about one inch wider than the width of column they are made to take.

12-inch News, all brass	\$2 00	24-inch News, all brass	\$3 00
16-inch News, all brass	2 50	24-inch Book, all brass	3 50

In ordering, give exact width of columns.

PLATE ZINC STORAGE GALLEYS.

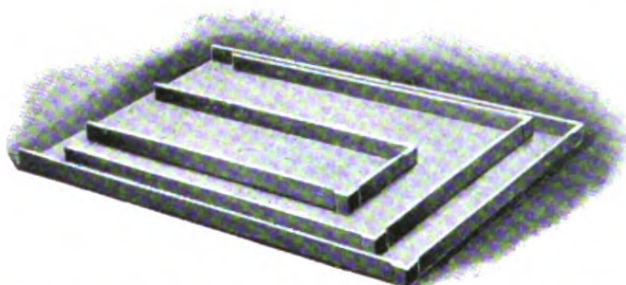

These galleys are shaped in special moulds, the corners reinforced, making them very substantial and durable. They are especially desirable for storage purposes where machine type-setting and Linotype machines are used. The material used is double-rolled plate zinc, especially made for this purpose.

Single column, 3½ × 23⅞ inches inside, each	\$1 00
Double column, 6¼ × 23⅞ inches inside, each	1 25

MAY'S PATENTED LEADER AND SORT BOX.

It occupies a most convenient position on the lower case, thus avoiding the long reach to the upper case. Covering just half the lower-case "e" box, and utilizing all spaces of partitions, etc., it does not obstruct the free use of a single sort in either case. The steel points on under side and two side arms hold the box firmly in position, with no danger of its being upset. The box is made to fit the only place a box can occupy on the case without covering copy or any of the sorts. (See location of box in illustration.)

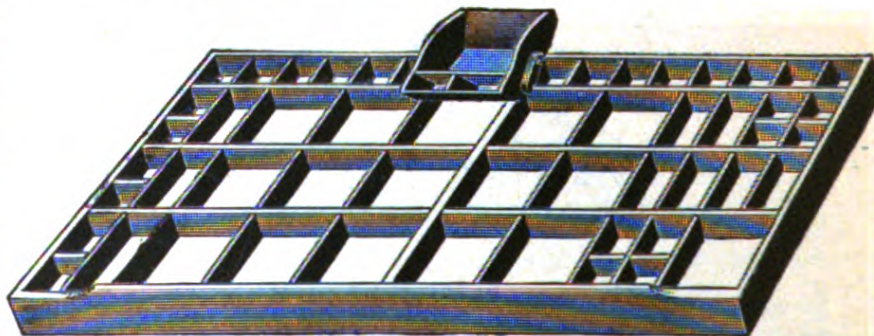

Price, single	\$0 50	Per dozen	\$5 00
-------------------------	--------	---------------------	--------

BRUCE TYPE FOUNDRY, 13 CHAMBERS STREET, NEW YORK.

EVERYTHING FOR THE PRINTER.

MAHOGANY AND IRON STEREOTYPE BLOCKS.

Mahogany Blocks are made of the best San Domingo mahogany, thoroughly seasoned, and are first-class in every detail. All blocks are made to order at short notice.

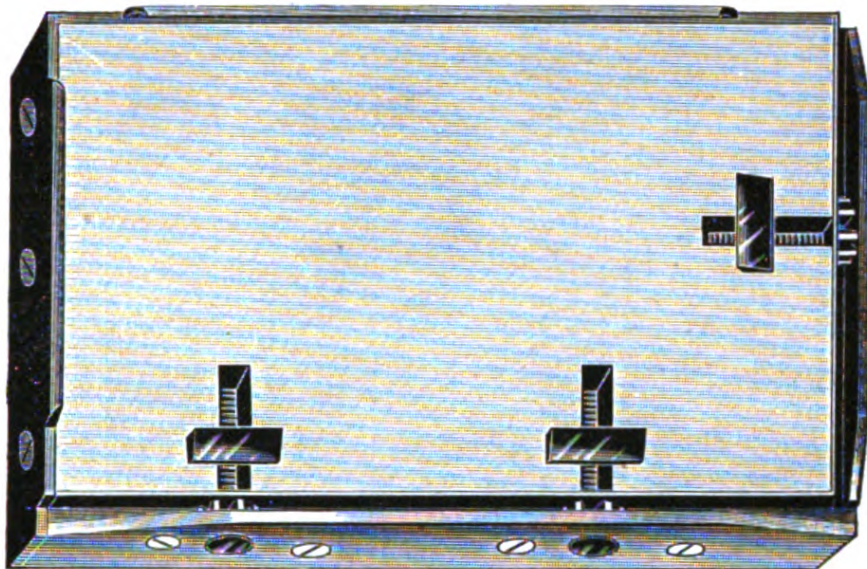

New Style Block, with Improved Side and End Hooks.

IMPORTANT POINTS.

Do not order a set of blocks, nor make up a form of patent blocks for press, until you know the exact size of chase that must hold the blocks, and the thickness and position of its cross-bars. Ascertain also the exact size of paper for which the blocks are intended, and whether the leaves of paper, after printing, are to be cut or uncut, and to be sewed or stitched. In making up blocks, if paper is to be uncut and sewed, allow nothing for loss by waste on the fore edge; if it is to be side-stitched and trimmed, make suitable allowance for margin that will be concealed by wire stitching in binding.

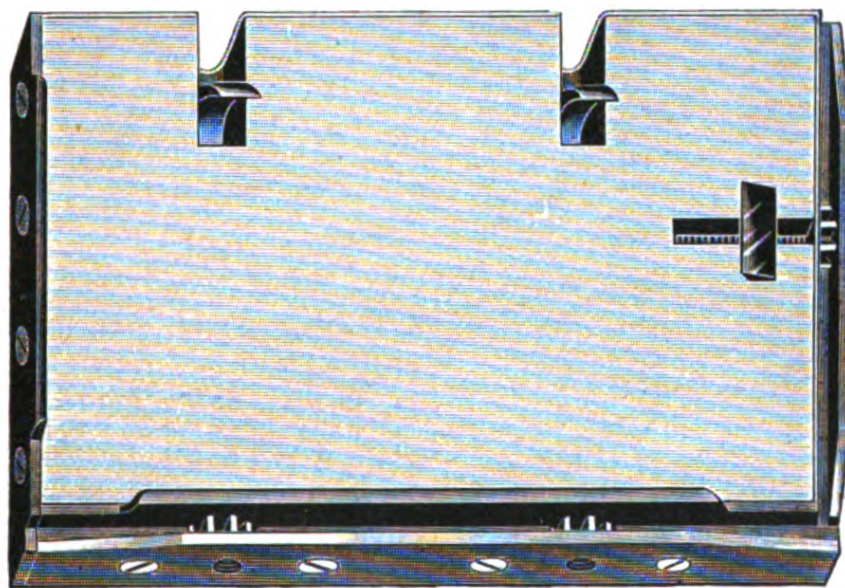

Plain Old Style Block.

CAUTION—To Avoid Errors. In sending orders, give the size of each block outside, and also the size of largest and smallest plate to be worked, *measuring the back of the plate*; or add $\frac{3}{4}$ of an inch to the printing matter, as follows, viz.: If the matter is 3×5 , the blocks should be $3\frac{3}{4} \times 5\frac{3}{4}$ outside, the bevel on the plate being about $\frac{1}{8}$. The hook and pinion will take $\frac{5}{8}$ with a little allowance for taking the plate free. All blocks are made $\frac{3}{4}$ -inch thick, unless otherwise ordered.

BRUCE TYPE FOUNDRY, 13 CHAMBERS STREET, NEW YORK.

EVERYTHING FOR THE PRINTER.

PRICE LIST OF MAHOGANY STEREOTYPE BLOCKS WITHOUT END HOOKS.

For Platen Presses.

To get the price of blocks with head brass, but no end hook, take the price of the next largest size in Price List. Add 50 cents each for extra hooks and pinions inserted in blocks.

SIZE.	Outside Dimensions of Blocks.	*Size of Smallest Plate incl'd'g Bevel.	No. of Side Hooks.	Imp. Plain Old Style.	Patent New Style.	Patent New Style Iron.	Proper Number of Blocks to Work a Sheet of Paper.
Folio—							
Imperial	16 × 22½	14¾ × 21¾	4	\$5 00	\$6 25	\$16 00	4 blocks to 33 × 46
Super-Royal	13½ × 21½	12¾ × 20¾	4	4 55	5 70	15 00	2 blocks to 22 × 28
Royal	12½ × 19½	11¾ × 18¾	4	4 20	5 25	14 00	4 blocks to 26 × 40
Medium	11½ × 18½	10¾ × 17¾	4	3 90	4 80	13 00	4 blocks to 24 × 38
Quarto—							
Imperial	11 × 16	9¾ × 14¾	4	3 75	4 50	12 00	8 blocks to 33 × 46
Super-Royal	10½ × 13½	9¾ × 12¾	3	3 10	3 75	10 50	4 blocks to 22 × 28
Royal	9½ × 12½	8¾ × 11¾	3	2 95	3 50	10 00	8 blocks to 26 × 40
Medium	9 × 11½	7¾ × 10¾	3	2 80	3 30	9 50	8 blocks to 24 × 38
Octavo—							
Imperial	7¾ × 11	6½ × 9¾	3	2 65	3 10	9 00	16 blocks to 33 × 46
Super-Royal	6½ × 10½	5¾ × 9¾	3	2 50	2 90	8 50	8 blocks to 22 × 28
Royal	6 × 9½	4¾ × 8¾	3	2 40	2 75	8 00	16 blocks to 26 × 40
Medium	5½ × 9	4¾ × 7¾	3	2 30	2 60	7 75	16 blocks to 24 × 38
Demy	5¼ × 7¾	4 × 6½	3	2 20	2 45	7 50	32 blocks to 33 × 46
Duodecimo—							
Broad	5¼ × 6¾	4 × 5½	2	1 65	1 90	..	24 blocks to 23 × 41
16mo—							
Super-Royal	5 × 6½	3¾ × 5¾	2	1 50	1 70	..	16 blocks to 22 × 28
Medium	4½ × 6	3¾ × 4¾	2	1 40	1 60	..	32 blocks to 26 × 40
Demy	3¾ × 5¼	2½ × 4	2	1 30	1 50	..	32 blocks to 23 × 33
18mo—							
Medium	3¾ × 5¼	2¾ × 4½	2	1 30	1 50	..	18 blocks to 19 × 24
32mo—							
Super-Royal	3 × 5	1¾ × 3¾	2	1 20	1 40	..	32 blocks to 22 × 28

* A block will take on a plate ½-inch smaller each way than the outside dimensions of the plate.

PRICE LIST OF MAHOGANY STEREOTYPE BLOCKS WITH END HOOKS.

For Cylinder Presses.

See "Caution" and other information on opposite page before ordering.

SIZE.	Outside Dimensions of Blocks.	*Size of Smallest Plate incl'd'g Bevel.	No. of Side Hooks.	No. of End Hooks.	Imp. Plain Old Style.	Patent New Style.	Patent New Style Iron.	Proper Number of Blocks to Work a Sheet of Paper.
Folio—								
Imperial	16 × 22½	14¾ × 21¾	4	3	\$7 25	\$8 50	\$21 00	4 blocks to 33 × 46
Super-Royal	13½ × 21½	12¾ × 20¾	4	3	6 80	7 95	19 50	2 blocks to 22 × 28
Royal	12½ × 19½	11¾ × 18¾	4	3	6 40	7 45	18 25	4 blocks to 26 × 40
Medium	11½ × 18½	10¾ × 17¾	4	3	6 10	7 00	17 25	4 blocks to 24 × 38
Quarto—								
Imperial	11 × 16	9¾ × 14¾	4	2	5 30	6 10	15 00	8 blocks to 33 × 46
Super-Royal	10½ × 13½	9¾ × 12¾	3	2	4 50	5 25	13 50	4 blocks to 22 × 28
Royal	9½ × 12½	8¾ × 11¾	3	2	4 25	4 90	12 75	8 blocks to 26 × 40
Medium	9 × 11½	7¾ × 10¾	3	2	4 00	4 60	12 25	8 blocks to 24 × 38
Octavo—								
Imperial	7¾ × 11	6½ × 9¾	3	1	3 30	3 80	10 75	16 blocks to 33 × 46
Super-Royal	6½ × 10½	5¾ × 9¾	3	1	3 15	3 60	10 00	8 blocks to 22 × 28
Royal	6 × 9½	4¾ × 8¾	3	1	3 00	3 40	9 50	16 blocks to 26 × 40
Medium	5½ × 9	4¾ × 7¾	3	1	2 85	3 25	9 00	16 blocks to 24 × 38
Demy	5¼ × 7¾	4 × 6½	3	1	2 70	3 10	8 50	32 blocks to 33 × 46
Duodecimo—								
Broad	5¼ × 6¾	4 × 5½	2	1	2 05	2 45	..	24 blocks to 23 × 41
16mo—								
Super-Royal	5 × 6½	3¾ × 5¾	2	1	1 95	2 30	..	16 blocks to 22 × 28
Medium	4½ × 6	3¾ × 4¾	2	1	1 85	2 15	..	32 blocks to 26 × 40
Demy	3¾ × 5¼	2½ × 4	2	1	1 75	2 00	..	32 blocks to 23 × 33
18mo—								
Medium	3¾ × 5¼	2¾ × 4½	2	1	1 75	2 00	..	18 blocks to 19 × 24
32mo—								
Super-Royal	3 × 5	1¾ × 3¾	2	1	1 65	1 85	..	32 blocks to 22 × 28

* A block will take on a plate ½-inch smaller each way than the outside dimensions of the plate.

See following page for Price List of Stereotype Sectional Metal Blocks.

BRUCE TYPE FOUNDRY, 13 CHAMBERS STREET, NEW YORK.

EVERYTHING FOR THE PRINTER.

WESEL PATENT IRON GROOVED BLOCK

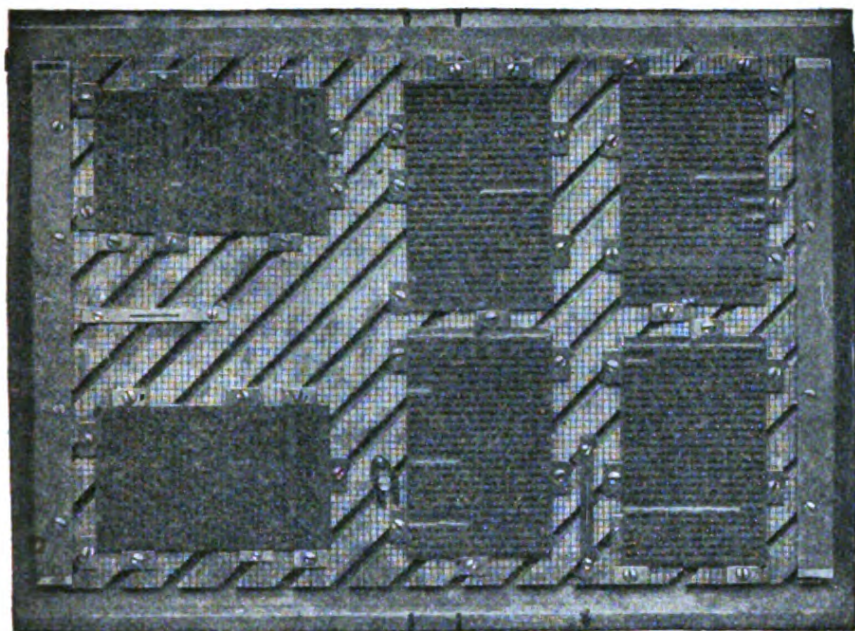

Completely meets the most exacting demands of those who print from plates, especially on three-color process work, and where close register is essential. It is a solid iron block, usually made to cover the maximum printing capacity of a press, 3/4-inch high, lined over its surface in squares of one Pica, with diagonal grooves cut in it one inch apart. In these grooves patent hooks are placed in such a way that they will hold any size of plate, allowing very close margins if necessary. No chase or furniture of any kind is needed with this block. Register is obtained quickly and positively. Points for folding machines of all makes are furnished, and can be placed in the correct positions. These blocks are also made for job presses, and in that case roller bearers are attachable, as shown in illustration.

Wesel Patent Iron Grooved Block for Cylinder and Job Presses. This illustration shows the block made to fit job press without chase.

Prices on application. State size of bed of press for which block is required, and also maximum size of form press will print.

STEREOTYPE SECTIONAL METAL BLOCKS

Consist of metal sections, made up of pieces 2x4, 2x8, 4x4, 4x8, and 8x8 ems Pica. Hooks are inserted in the largest sections, which may be arranged on any part of the block, and can be adapted for bed and platen or cylinder presswork. With an assortment of the sections or furniture the printer may, by a proper combination, prepare a set of blocks to take on a page of any size. The weight required for a page can be readily estimated by figuring 3 1/2 ounces to each square inch of back of plate. To extend size of sectional block, in case there is a shortage of sections, metal furniture not exceeding two ems Pica wide may be used. Our standard sectional blocks are made to take plates 11 points in thickness.

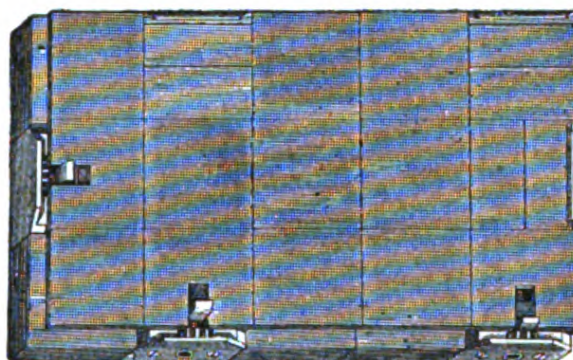

Sections with regular margin hook, each, \$1 00 | Brass catches, each \$0 15
 Sections with narrow margin hook, each, 1 10 | Sections or furniture, per pound . 0 25

CHALLENGE NARROW-MARGIN BRASS REGISTER HOOKS

For Three-Color Printing.

These hooks are intended for color printing. Six hooks to each average-size plate. They are placed on all sides of the plate, and by use of a small key the hook on one side is released, and the one opposite is tightened. By this means a plate may be moved the smallest fraction of an inch, and as each plate is registered independently it will be readily understood how easily and quickly a whole form of plates may be made to register absolutely.

We furnish to order sectional blocks in brass or iron, and all kinds of special combination blocks for book and color printing. Estimates on application.

Brass Register Hooks, each 6x6 ems, net \$1 25

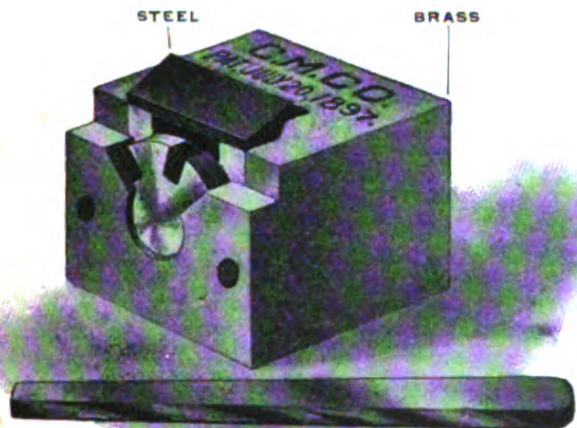

BRUCE TYPE FOUNDRY, 13 CHAMBERS STREET, NEW YORK.

EVERYTHING FOR THE PRINTER.

WEATHERLY EXTENSION BLOCKS.

IRON OR MAHOGANY.

Takes on a Plate any Size. Has all the Good Qualities of the Old-time Patent Stereotype Block and the Great Advantage of being Adjustable to Plates of Various Sizes.

The material and workmanship employed in the manufacture of these Blocks are the very best obtainable. They are made with the utmost precision and are in the front rank of modern inventions for producing the best results in printing.

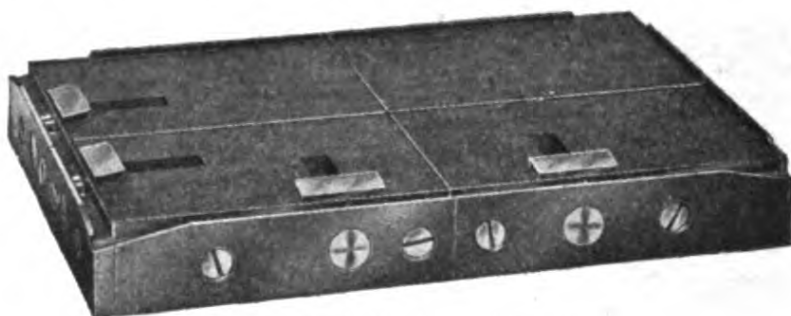

Fig. 1.—Block Without Extensions.

The cut (Fig. 1) shows the Block without extensions. The four corner sections are separate and made to a standard size, each measuring 2×3 inches, and when placed together, forming the Block as shown, they measure 4×6 inches, and will take on a plate any size from $2\frac{5}{8} \times 4\frac{5}{8}$ to $3\frac{3}{8} \times 5\frac{7}{16}$ inches.

It is often necessary to work narrow margins on plates of small size, and in such cases the Parallel Strips for increasing the Blocks slightly, as by Picas, can be used to great advantage. There are twenty-eight of these strips for each Block, viz.: two pieces each, 1 and 2 ems Pica wide by 12, 18, 24, 36, 37, 38 and 39 Picas long. They are accurately made with rabbeted end (so as not to interfere with the ratcheting), and by their use the Block can be increased in width or length, or both, from one to six ems Pica, beyond which sizes the Crosses meet every requirement.

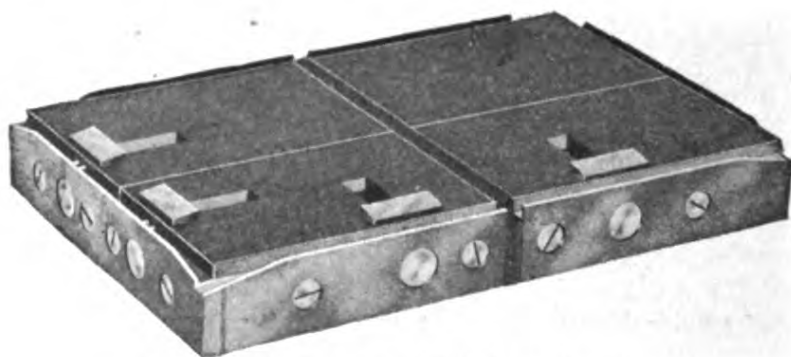

Fig. 2.—Block Extended in Length Only.

The cut (Fig. 2) shows the Block increased one Pica in length with a Parallel Strip. This can be increased to one inch without altering the width, if desired. Long, narrow plates are easily provided for in this manner. Printers will thoroughly appreciate this easy method of overcoming difficulties heretofore experienced with Blocks "a little too large" or "a bit too small."

There is not only a great deal of satisfaction in having on hand a set of Blocks that will take plates of any size that may come along, but there is obviously great economy in such Blocks. Often profitable work is turned away on account of not having Blocks of the necessary size, particularly if it happens to be an odd size seldom used. Other work is lost by not having Blocks of the desired size nor the time to order them specially made. All of this is a thing of the past—the printer having a set of Weatherly Extension Blocks is always ready, and if he has not purchased them they can be had promptly from stock, in mahogany or iron, at any time.

EVERYTHING FOR THE PRINTER.

WEATHERLY EXTENSION BLOCKS.

(Continued.)

The cut (Fig. 3) shows the Block extended, in width only, by use of a Parallel Strip 1 Pica wide by 36 Picas long. This can be increased to one inch without altering the length, thus taking on short, wide plates very conveniently.



Fig. 3.—Block Extended in Width Only.

The three Crosses shown as Fig. 6 are the principal extensions, and fully meet the requirements in all cases, except where narrow margins must be worked. Cross A is $4\frac{1}{2} \times 6\frac{3}{4}$ inches outside, and when used with the corner sections will take any size plate from $3\frac{1}{8} \times 5\frac{3}{8}$ to $3\frac{3}{8} \times 6\frac{3}{16}$ inches. Cross B is $5\frac{1}{4} \times 7\frac{3}{4}$ inches, and with the corner sections takes plates any size from $3\frac{3}{8} \times 6\frac{3}{8}$ to $4\frac{11}{16} \times 7\frac{3}{16}$ inches. Cross C is 6×9 inches, and with corner sections will take plates any size from $4\frac{5}{8} \times 7\frac{5}{8}$ to $5\frac{3}{8} \times 8\frac{7}{16}$ inches. It will be seen that the three regular-size Crosses cover all size plates from $2\frac{5}{8} \times 4\frac{5}{8}$ to $5\frac{3}{8} \times 8\frac{7}{16}$ inches, and all above sizes can be increased at least one Pica each way by using the Pica Parallel Strips in connection with the Crosses.

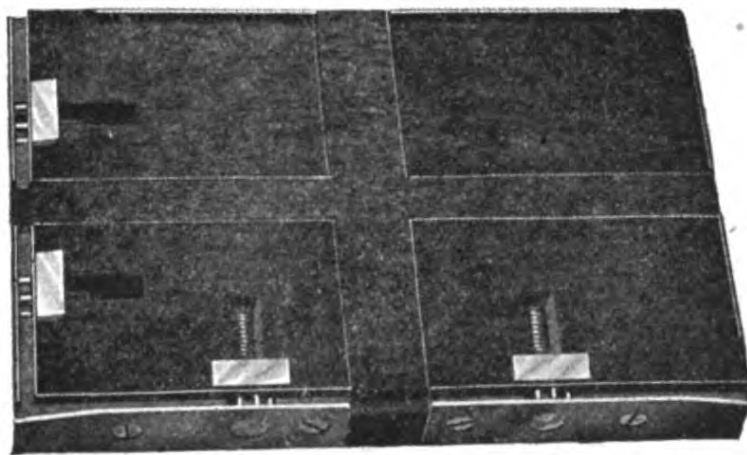

Fig. 4.—Block Extended Proportionately with Cross.

The cut (Fig. 4) shows the Block extended proportionately by use of Cross A, forming a complete Block $4\frac{1}{2} \times 6\frac{3}{4}$ inches outside. All the Crosses are accurately made, and the corner sections fit snugly. The Block will lock up in a form as well as if made in one solid piece.

No cuts showing Block with Crosses B and C are printed herewith as they are exactly like Cross A, except in sizes, which are given elsewhere.

The cut (Fig. 5) shows Block with a Cross of special large size and extra hook and clamp. In cases where it is desired to work an unusually large plate beyond the scope of Cross C, special Crosses of the size desired must be made to order. There is no limit to the size of special Crosses, which will be supplied promptly at moderate cost. In ordering them give the size of the printed page (type matter) or back measurement of plate to be worked. If hooks and clamps are desired on Crosses, be careful to state the number wanted. Prices of special Crosses, with or without hooks and clamps, quoted upon application.

EVERYTHING FOR THE PRINTER.

WEATHERLY EXTENSION BLOCKS.

(Continued.)

The cut (Fig. 6) shows three Extension Crosses, the larger one with hook and clamp. The four recesses in the Crosses are accurately made to a standard size, viz.: 2×3 inches, and the corner sections may always be relied upon to fit any regular or special Cross perfectly.

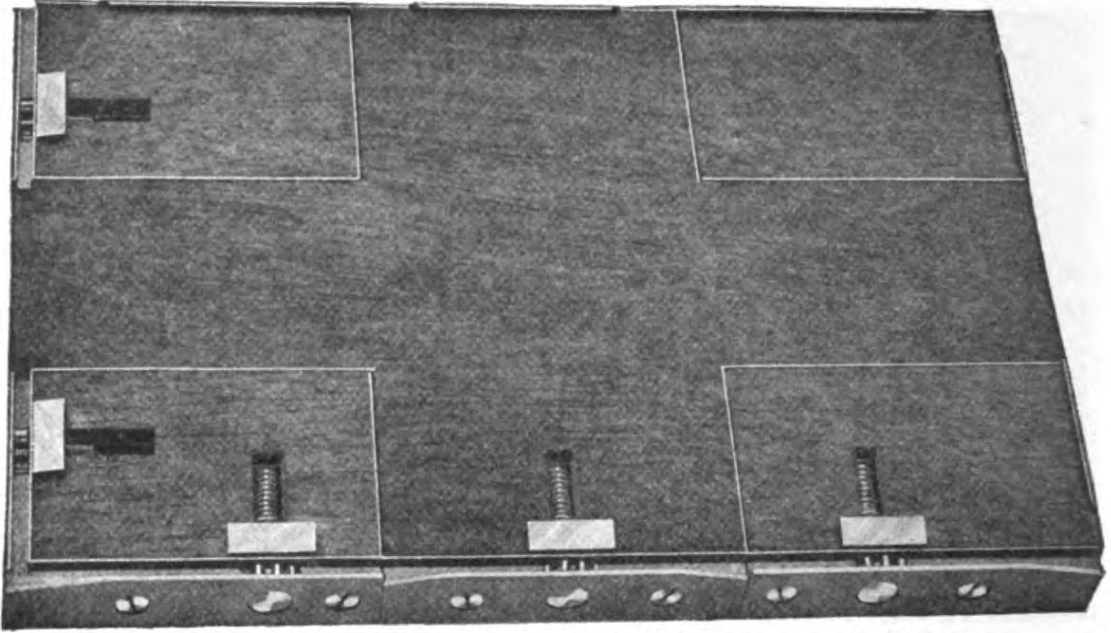

Fig. 5.—Block with Special Large Cross, showing Extra Hook and Clamp.

There are an equal number of right and left Crosses with each set of Blocks, and they are distinctly marked *R* and *L*, the same as the corner sections, to simplify and facilitate making up the Blocks in forms. The mahogany Crosses are cut out of a solid block of wood, and made with special machinery built to secure the utmost accuracy. While simple in appearance they require the greatest care in manufacturing, and are examined and gauged before being sent out from the factory.

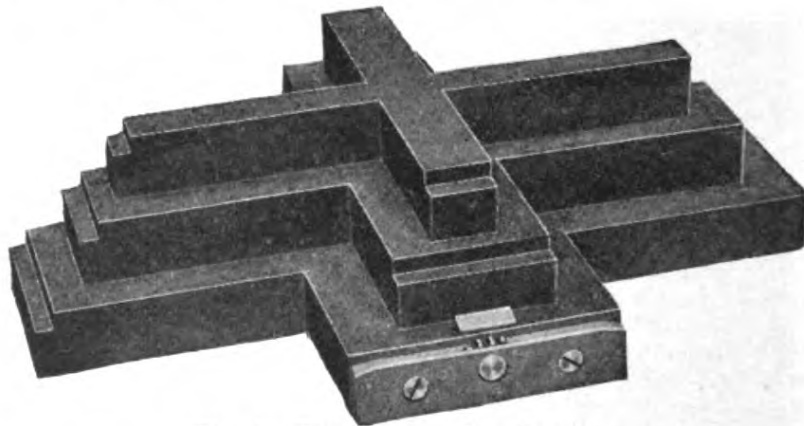

Fig. 6.—Three Extension Crosses.

The cut (Fig. 7) shows a set of thirty-two Blocks, complete with Crosses and Parallel Strips, in a substantial and handsomely made cabinet specially designed to hold them to the best advantage and save them from being lost or damaged. Sets of sixteen Blocks are put up in smaller cabinets in the same manner. The Corner Pieces and Crosses all rest on their edges when in the cabinet, and while in this position are not likely to be affected in any way by undue heat or moisture, as might be the case if left to lay flat on their sides when not in use. The cabinets also contain three compartments for ratchets, etc.

BRUCE TYPE FOUNDRY, 13 CHAMBERS STREET, NEW YORK.

EVERYTHING FOR THE PRINTER.

WEATHERLY EXTENSION BLOCKS.

(Continued.)

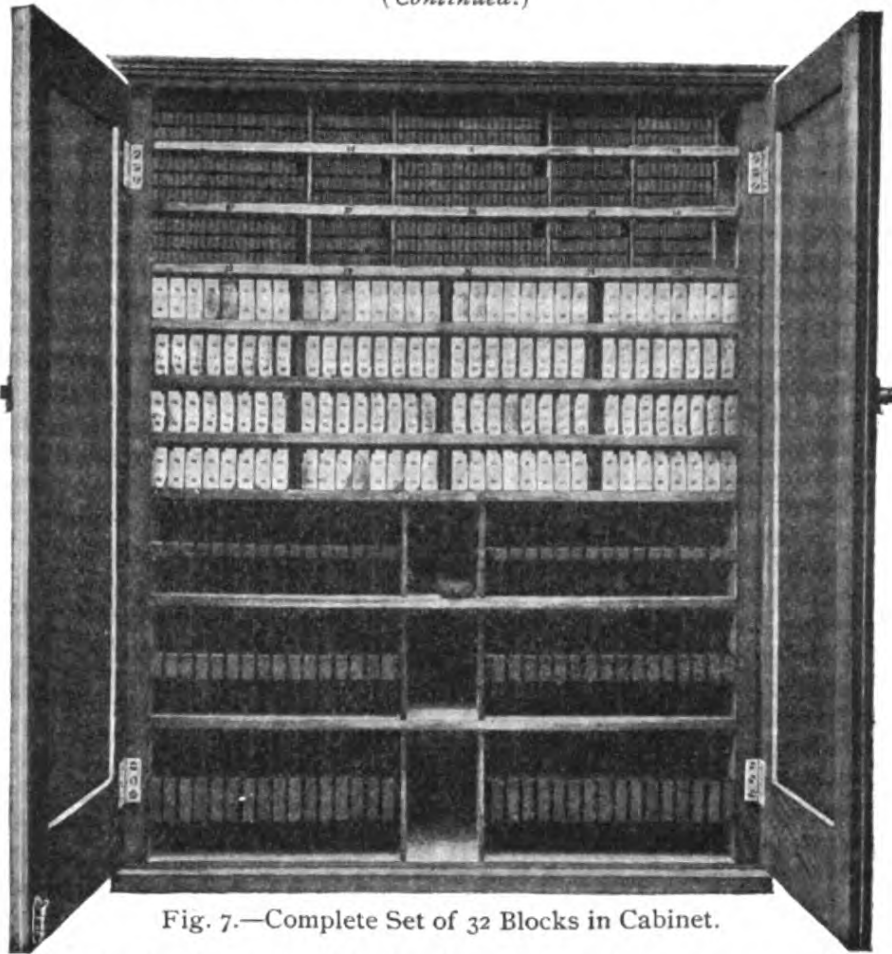

Fig. 7.—Complete Set of 32 Blocks in Cabinet.

The Iron Weatherly Extension Blocks differ from the Mahogany Blocks in material only. The four Corner Sections and largest Cross are made of iron, the hooks and clamps are brass, and the two small Crosses and Parallel Strips are made of steel bars, all highly finished in a most superior, workmanlike manner.

The Iron Blocks produce the very best results and save much time in making ready, the underlays on the back of plates being more effective when placed between the plate and the rigid iron base. They meet every possible requirement in printing book plates and half-tones. These Blocks are very serviceable in job offices having long runs of circulars, etc., where two, four or eight are run to a sheet, only requiring plates to be made, which are much cheaper than electrotypes mounted on wood. A set of four or eight of these Blocks will soon pay for themselves by the saving on electrotyping and presswork only.

BLOCK WITH DIFFERENT EXTENSIONS.

	Block Without Extensions.	With Cross A.	With Cross B.	With Cross C.
Outside dimensions of Blocks	4 × 6	4½ × 6¾	5¼ × 7¾	6 × 9
Largest Plate, including Bevel	3¾ × 5½	3¾ × 6¾	4½ × 7½	5¾ × 8½
Smallest Plate, including Bevel	2¾ × 4¾	3¾ × 5¾	3¾ × 6¾	4¾ × 7¾

PRICE LIST.

Mahogany Block, without Extensions	\$3 00
Iron Block, without Extensions	6 00

Extensions may be purchased as required at following prices: . . . Mahogany. . . Iron.

Crosses A and B, each	\$0 50	\$1 00
Cross C, each	0 50	1 25
Set of Parallel Strips (for each Block)	0 50	1 50

Cabinets for 16 Blocks, \$10 00; Cabinets for 32 Blocks, \$15 00.

Four sets of ordinary Stereotype Blocks, at an additional cost of 60 per cent., are required to work the same number and sizes of plates taken on by one set of sixteen Weatherly Extension Blocks.

No more waiting for Blocks to be made to order. These are carried in stock for immediate delivery.

BRUCE TYPE FOUNDRY, 13 CHAMBERS STREET, NEW YORK.

EVERYTHING FOR THE PRINTER.

WROUGHT IRON CHASES.

These Chases are Unexcelled for Accuracy, Squareness and Strength.

IMPORTANT.—In ordering chases mistakes will be avoided by observing the following instructions :

Give outside measurements.

Where chase or chases are to fit press, give actual size of bed. An allowance of $\frac{1}{8}$ inch will be made in length of chases.

If chases are to be made from other than regular stock, state size desired.

If side sticks are ordered, state whether they are to be straight or beveled, and give length of forms if other than standard newspaper size.

Bearer chases cost one-half more than regular chases.

Steel chases cost one-half more than wrought iron chases.

NEWSPAPER CHASES—Folio.

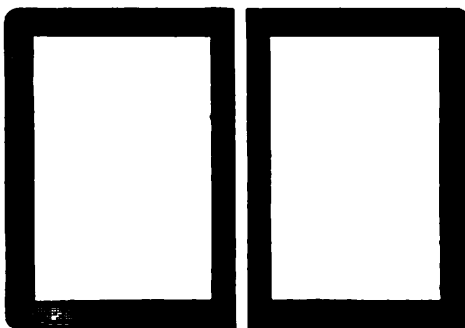

Twin or Folio Chases.

Number.	Column Folio.	Size of Pair Over All. Inches.	Chase Size Each Outside Inches.	Measurement Length and Breadth Over All. Inches.	Size of Material.†			Price of Pair.
					Width of Side Bars. Inches.	Width of End Bars. Inches.	Width of Back Bars. Inches.	
1	*5	28 × 21 $\frac{3}{4}$	14 × 21 $\frac{3}{4}$	49 $\frac{3}{4}$	1 $\frac{1}{8}$	1 $\frac{1}{8}$	1 $\frac{1}{8}$	\$ 9 50
2	5	29 $\frac{3}{8}$ × 22 $\frac{1}{4}$	14 $\frac{1}{8}$ × 22 $\frac{1}{4}$	51 $\frac{5}{8}$	1 $\frac{1}{8}$	1 $\frac{1}{8}$	1 $\frac{1}{8}$	9 90
3	*6	32 $\frac{1}{2}$ × 24	16 $\frac{1}{4}$ × 24	56 $\frac{1}{2}$	1 $\frac{1}{8}$	1 $\frac{1}{8}$	1 $\frac{1}{8}$	10 85
4	6	33 $\frac{7}{8}$ × 24	16 $\frac{1}{8}$ × 24	57 $\frac{7}{8}$	1 $\frac{1}{8}$	1 $\frac{1}{8}$	1 $\frac{1}{8}$	11 00
5	*7	38 × 25 $\frac{3}{4}$	19 × 25 $\frac{3}{4}$	63 $\frac{3}{4}$	1 $\frac{1}{8}$	1 $\frac{1}{8}$	1 $\frac{1}{8}$	12 15
6	7	38 $\frac{7}{8}$ × 26	19 $\frac{7}{8}$ × 26	64 $\frac{7}{8}$	1 $\frac{1}{8}$	1 $\frac{1}{8}$	1 $\frac{1}{8}$	12 35
7	*7×6	41 × 27	20 $\frac{1}{2}$ × 27	68	1 $\frac{1}{8}$	1 $\frac{1}{8}$	1 $\frac{1}{8}$	12 90
8	*8	42 × 28	21 × 28	70	1 $\frac{1}{4}$	1 $\frac{1}{4}$	1 $\frac{1}{4}$	13 30
9	8	43 $\frac{5}{8}$ × 28 $\frac{1}{4}$	21 $\frac{1}{8}$ × 28 $\frac{1}{4}$	71 $\frac{7}{8}$	1 $\frac{1}{4}$	1 $\frac{1}{4}$	1 $\frac{1}{4}$	13 70
10	*9	47 × 30 $\frac{1}{2}$	23 $\frac{1}{2}$ × 30 $\frac{1}{2}$	77 $\frac{1}{2}$	1 $\frac{1}{4}$	1 $\frac{1}{4}$	1 $\frac{1}{4}$	14 80
11	9	48 $\frac{3}{8}$ × 30 $\frac{1}{4}$	24 $\frac{3}{8}$ × 30 $\frac{1}{4}$	78 $\frac{5}{8}$	1 $\frac{1}{4}$	1 $\frac{1}{4}$	1 $\frac{1}{4}$	15 00
12	Paper 24x36	40 × 26 $\frac{1}{4}$	20 × 26 $\frac{1}{4}$	66 $\frac{1}{4}$	1 $\frac{1}{8}$	1 $\frac{1}{8}$	1 $\frac{1}{8}$	12 75

*These measures allow for 13 ems pica columns and 7 point column rules, except for 9-column paper, when 8 point column rules are used, allowing 1 $\frac{1}{4}$ inches for lock-up.

†Thickness of iron used in above chases is $\frac{3}{8}$ inch.

To Estimate Price of Twin or Folio Chases, Sizes not Listed:

Add length and breadth of pair over all in inches and multiply by 19 cents per inch.

In figuring extra stock charges, consider each chase separately; charges will be same as for Poster chase.

Minimum price per pair of Twin or Folio chases, \$9 00.

See Poster list for figuring measurements ending in fractions.

BRUCE TYPE FOUNDRY, 13 CHAMBERS STREET, NEW YORK.

EVERYTHING FOR THE PRINTER.

NEWSPAPER CHASES—Quarto.

Size No.	Col. Quarto	Size of Pair Over All. Inches.	Size of Each Chase Outside. Inches.	Measurement Length and Breadth Over All. Inches.	Size of Material.†				Price of Pair
					Width of Side Bars. Inches.	Width of End Bars. Inches.	Width of Back Bars. Inches.	Width of Cross Bars. Inches.	
13	*4	35 $\frac{7}{8}$ × 24 $\frac{1}{4}$	17 $\frac{1}{8}$ × 24 $\frac{1}{4}$	60 $\frac{1}{8}$	1 $\frac{1}{8}$	1 $\frac{1}{8}$	1 $\frac{3}{8}$	1	\$13 40
14	4	36 × 24 $\frac{1}{2}$	18 × 24 $\frac{1}{2}$	60 $\frac{1}{2}$	1 $\frac{1}{8}$	1 $\frac{1}{8}$	1 $\frac{3}{8}$	1	13 40
15	*5	43 × 28 $\frac{1}{2}$	21 $\frac{1}{2}$ × 28 $\frac{1}{2}$	71 $\frac{1}{2}$	1 $\frac{1}{8}$	1 $\frac{1}{8}$	1 $\frac{3}{8}$	1	15 85
16	5	44 $\frac{1}{8}$ × 29 $\frac{1}{2}$	22 $\frac{1}{8}$ × 29 $\frac{1}{2}$	73 $\frac{5}{8}$	1 $\frac{1}{8}$	1 $\frac{1}{8}$	1 $\frac{3}{8}$	1	16 30
17	*6	46 × 32 $\frac{1}{2}$	23 × 32 $\frac{1}{2}$	78 $\frac{1}{2}$	1 $\frac{1}{4}$	1 $\frac{1}{4}$	1 $\frac{3}{8}$	1	17 40
18	*6	47 × 32 $\frac{1}{2}$	23 $\frac{1}{2}$ × 32 $\frac{1}{2}$	79 $\frac{1}{2}$	1 $\frac{1}{4}$	1 $\frac{1}{4}$	1 $\frac{3}{8}$	1	17 60
19	6	47 $\frac{5}{8}$ × 34	23 $\frac{3}{8}$ × 34	81 $\frac{5}{8}$	1 $\frac{1}{4}$	1 $\frac{1}{4}$	1 $\frac{3}{8}$	1	18 05
20	*7	51 × 37 $\frac{1}{2}$	25 $\frac{1}{2}$ × 37 $\frac{1}{2}$	88 $\frac{1}{2}$	1 $\frac{5}{8}$	1 $\frac{5}{8}$	1 $\frac{3}{8}$	1	19 60
21	7	52 $\frac{1}{8}$ × 39	26 $\frac{1}{8}$ × 39	91 $\frac{1}{8}$	1 $\frac{5}{8}$	1 $\frac{5}{8}$	1 $\frac{3}{8}$	1	20 25
22	*8	56 $\frac{1}{8}$ × 43 $\frac{1}{2}$	28 $\frac{1}{8}$ × 43 $\frac{1}{2}$	99 $\frac{5}{8}$	1 $\frac{5}{8}$	1 $\frac{5}{8}$	1 $\frac{3}{8}$	1	22 00

*These measures allow for 13 ems pica columns and 7 point column rules, except for 9-column paper, when 8 point column rules are used, allowing 1 $\frac{3}{4}$ inches for lock-up.

†Thickness of iron used in above chases is $\frac{5}{8}$ inch.

To Estimate Price per Pair of Quarto Chases, Sizes not Listed:

Add length and breadth of pair over all in inches and multiply by 22 cents per inch.

In figuring extra stock charges, consider each chase separately; charges will be the same as for Poster chase.

Minimum price for pair of Quarto chases, \$12 00.

See Poster list for figuring measurements ending in fractions.

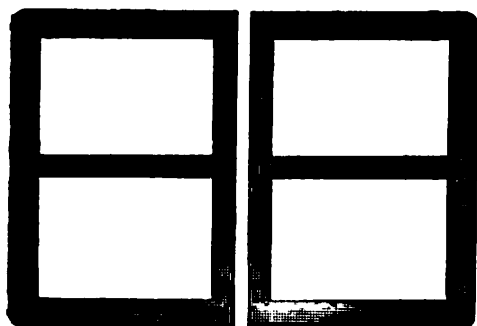

Twin or Quarto Chases with Bars.

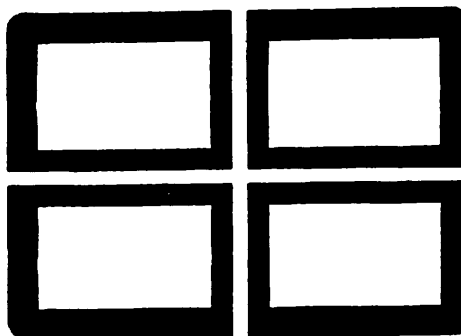

Quadruple Chases.

QUADRUPLE CHASES.

Size No.	Column Quadruple.	Size of Pair Over All. Inches.	Size of Each Chase Outside. Inches.	Measurement Length and Breadth Over All. Inches.	Size of Material.†				Price for Set of Four.
					Width of Side Bars. Inches.	Width of Inside End Bars. Inches.	Width of Outside End Bars. Inches.	Width of Back Bars. Inches.	
23	5	28 × 42 $\frac{1}{2}$	14 × 21 $\frac{1}{4}$	70 $\frac{1}{2}$	1 $\frac{1}{8}$	1 $\frac{3}{8}$	1 $\frac{1}{8}$	1 $\frac{3}{8}$	\$19 90
24	6	32 $\frac{1}{2}$ × 47	16 $\frac{1}{4}$ × 23 $\frac{1}{2}$	79 $\frac{1}{2}$	1 $\frac{1}{8}$	1 $\frac{3}{8}$	1 $\frac{1}{8}$	1 $\frac{3}{8}$	22 40
25	7	38 × 50 $\frac{1}{2}$	19 × 25 $\frac{1}{4}$	88 $\frac{1}{2}$	1 $\frac{1}{8}$	1 $\frac{3}{8}$	1 $\frac{1}{8}$	1 $\frac{3}{8}$	24 90

†Thickness of iron used in above chases is $\frac{5}{8}$ inch.

To Estimate Price of a Set of Quadruple Chases, Sizes not Listed:

Add length and breadth in inches of set over all and multiply by 28 cents per inch.

In figuring extra stock charges consider each chase separately; charges will be the same as for Poster chase.

Minimum price for set of Quadruple chases, \$18 00.

See Poster list for figuring measurements ending in fractions.

BRUCE TYPE FOUNDRY, 13 CHAMBERS STREET, NEW YORK.

EVERYTHING FOR THE PRINTER.

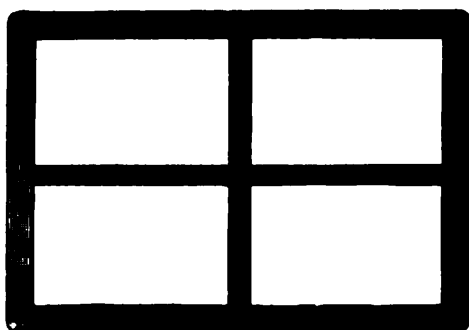

**BOOK
CHASES.**

With Solid Cross Bar
and with
Both Bars Shifting.

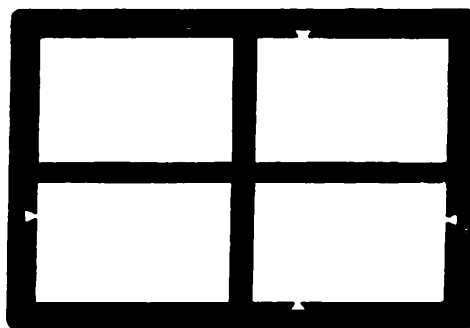

Size No.	Outside Measurement. Inches.	Measurement Length and Breadth. Inches.	Width of Iron.*		Price of Chase with Solid Cross Bars.	Price of Chase One Bar Shifting.	Price of Chase Both Bars Shifting.
			Side Bars.	End Bars.			
26	17 × 21	38	1	1	\$ 8 50	\$ 9 50	\$10 50
27	20 × 25	45	1 1/8	1 1/8	8 95	9 95	10 95
28	21 × 27	48	1 1/8	1 1/8	9 30	10 30	11 30
29	22 × 27	49	1 1/8	1 1/8	9 40	10 40	11 40
30	22 × 28	50	1 1/8	1 1/8	9 50	10 50	11 50
31	23 × 29	52	1 1/8	1 1/8	9 70	10 70	11 70
32	24 × 30	54	1 1/8	1 1/8	9 95	10 95	11 95
33	25 × 30	55	1 1/8	1 1/8	10 05	11 05	12 05
34	26 × 32	58	1 1/8	1 1/8	10 40	11 40	12 40
35	26 × 34	60	1 1/8	1 1/8	10 60	11 60	12 60
36	25 × 35	60	1 1/8	1 1/8	10 60	11 60	12 60
37	26 × 36	62	1 1/8	1 3/8	10 80	11 80	12 80
38	27 × 39	66	1 1/8	1 3/8	11 25	12 25	13 25
39	29 × 41	70	1 1/8	1 3/8	11 70	12 70	13 70
40	29 × 42	71	1 1/8	1 3/8	11 80	12 80	13 80
41	30 × 42	72	1 1/8	1 3/8	11 90	12 90	13 90
42	32 × 44	76	1 1/8	1 3/8	12 35	13 35	14 35
43	32 × 46	78	1 1/8	1 3/8	12 60	13 60	14 60
44	32 × 47	79	1 1/8	1 3/8	12 70	13 70	14 70
45	33 1/2 × 46	79 1/2	1 1/8	1 3/8	12 80	13 80	14 80
46	33 1/2 × 48	81 1/2	1 1/8	1 3/8	13 00	14 00	15 00
47	34 × 48	82	1 1/8	1 3/8	13 00	14 00	15 00
48	35 × 50	85	1 1/8	1 3/8	13 35	14 35	15 35
49	36 × 52	88	1 1/8	1 3/8	13 70	14 70	15 70
50	38 × 51	89	1 1/8	1 3/8	13 80	14 80	15 80
51	37 1/2 × 52	89 1/2	1 1/8	1 3/8	13 90	14 90	15 90
52	39 × 53	92	1 1/8	1 3/8	14 10	15 10	16 10
53	41 × 55	96	1 1/8	1 3/8	14 55	15 55	16 55
54	43 × 56	99	1 1/8	1 3/8	14 90	15 90	16 90
55	40 × 60	100	1 1/8	1 3/8	15 00	16 00	17 00
56	43 × 60	103	1 7/8	1 7/8	15 35	16 35	17 35
57	43 × 63	106	1 7/8	1 7/8	15 65	16 65	17 65
58	45 × 62	107	1 7/8	1 7/8	15 75	16 75	17 75
59	45 × 65	110	1 7/8	1 7/8	16 10	17 10	18 10
60	47 × 66	113	1 7/8	1 7/8	16 45	17 45	18 45

*Width of long cross bars, 5/8 inch. Width of short cross bars, 1 inch. Thickness of bars, 5/8 inch.

To Estimate Price of Book Chase, Size not Listed:

Find price of same size Poster or Skeleton chase and add \$4 00 if solid bars only are wanted.
Add \$5 00 if one bar only is to be shifted, and \$6 00 if both bars are to be shifted.
Minimum price of Book chase, with both bars shifting, \$10 50.
For bar only, add \$1 00 to list; for pair of dovetails, add \$1 00 to list; for both, add \$2 00 to list.
For extra stock, charge same as in Poster chases.
See Poster list for figuring measurements ending in fractions.

EVERYTHING FOR THE PRINTER.

POSTER CHASES.



Without Bar.

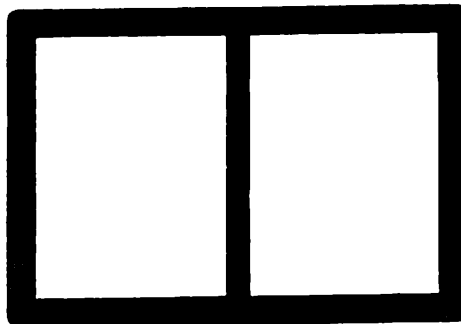

With Bar.

Number.	Outside Measurement Inches.		Measure-ment Length and Breadth. Inches.	Size of Material.*				Price of Poster Chase Without Bar.	Price of Poster Chase With Bar. Inches.
				Width of Side Bars.		Width of End Bars.			
				With Bar. Inches.	Without Bar. Inches.	With Bar. Inches.	Without Bar. Inches.		
61	17	× 21	38	1	1 1/8	1	1 1/8	\$ 4 50	\$ 6 50
62	20	× 25	45	1 1/8	1 1/8	1 1/8	1 1/8	4 95	6 95
63	21	× 27	48	1 1/8	1 1/8	1 1/8	1 1/8	5 30	7 30
64	22	× 28	50	1 1/8	1 1/8	1 1/8	1 1/8	5 50	7 50
65	24	× 30	54	1 1/8	1 1/8	1 1/8	1 1/8	5 95	7 95
66	26	× 32	58	1 1/8	1 1/8	1 1/8	1 1/8	6 40	8 40
67	25	× 35	60	1 1/8	1 1/8	1 1/8	1 1/8	6 60	8 60
68	27	× 39	66	1 3/8	1 1/4	1 1/8	1 1/4	7 25	9 25
69	29	× 42	71	1 3/8	1 1/4	1 1/8	1 1/4	7 80	9 80
70	32	× 46	78	1 3/8	1 1/4	1 1/8	1 1/4	8 60	10 60
71	32	× 47	79	1 3/8	1 1/4	1 1/8	1 1/4	8 70	10 70
72	33 1/2	× 48	81 1/2	1 3/8	1 3/8	1 1/8	1 3/8	9 00	11 00
73	34	× 50	84	1 3/8	1 3/8	1 1/8	1 3/8	9 25	11 25
74	35	× 52	87	1 3/8	1 3/8	1 1/8	1 3/8	9 55	11 55
75	37	× 54	91	1 3/8	1 3/8	1 1/8	1 3/8	10 00	12 00
76	39	× 53	92	1 3/8	1 3/8	1 1/8	1 3/8	10 10	12 10
77	39	× 55	94	1 3/8	1 3/8	1 1/8	1 3/8	10 35	12 35
78	41	× 55	96	1 3/8	1 3/8	1 1/8	1 3/8	10 55	12 55
79	43	× 60	103	1 7/8	1 1/2	1 1/8	1 1/2	11 35	13 35
80	47	× 66	113	1 7/8	1 1/2	1 1/8	1 1/2	12 45	14 45

*Width of cross bars, 1 inch. Thickness of bars, 3/8 inch.

To Estimate Price of a Poster Chase, Size not Listed :

Add length and breadth in inches together to obtain measure. Multiply this measure by 11 cents.

For price of News or Poster chase with bar, add \$2 00 to list of Poster without bar.

Minimum price of Poster chase, \$4 50.

For extra bar only, add \$1 00. For extra pair dovetails, add \$1 00.

Measurements ending in fractions to be figured as next full figure. For example: 17 × 20 1/4 in. — 37 3/4 in., figure 38 in.; 33 1/2 × 45 3/4 in. — 79 1/4 in., figure 80 in.; 29 3/8 × 40 1/2 in. — 69 3/8 in., figure 70 in.

CHARGES FOR EXTRA STOCK :

- For each 1/8 in. wider than regular, add for measurement (length and breadth) 40 ins. and smaller . \$0 40
- For each 1/8 in. wider than regular, add for measurement (length and breadth) 41 to 60 ins. incl. . . 0 65
- For each 1/8 in. wider than regular, add for measurement (length and breadth) 61 to 80 ins. incl. . . 0 90
- For each 1/8 in. wider than regular, add for measurement (length and breadth) 81 to 100 ins. incl. . . 1 15
- For each 1/8 in. wider than regular, add for measurement (length and breadth) 101 and larger . . . 1 40
- For 3/8 in. thick stock, add for measurement (length and breadth) 40 ins. and smaller 0 60
- For 3/8 in. thick stock, add for measurement (length and breadth) 41 to 60 ins. inclusive 1 00
- For 3/8 in. thick stock, add for measurement (length and breadth) 61 to 80 ins. inclusive 1 40
- For 3/8 in. thick stock, add for measurement (length and breadth) 81 to 100 ins. inclusive 1 80
- For 3/8 in. thick stock, add for measurement (length and breadth) 101 and larger 2 20
- For extra width and 3/8 inch thick stock, add both of the above advanced charges.

EVERYTHING FOR THE PRINTER.

HEADING CHASES.

Estimate Price of Heading Chase, Size not Listed, Same as Poster Chase:

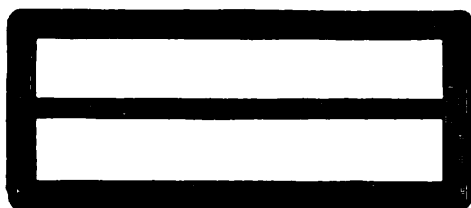

Minimum price of Heading chase without bar, \$4 50.

For bar and pair of dovetails, add \$2 00.

Unless otherwise ordered, cross-bar Heading chases will be furnished.

Figure extra stock same as in Poster chases.

See Poster list for figuring measurements ending in fractions.

Number.	Size of Chase Outside With Bar. Inches.	Size of Chase Inside. Inches.	Measurement Length and Breadth. Inches.	Size of Material.				Price of Chase Without Bar.	Price of Chase With Bar.
				Width of Side Bars.		Width of End Bars.			
				With Bar. Inches.	Without Bar. Inches.	With Bar. Inches.	Without Bar. Inches.		
81	8 × 19	6 × 17	27	1	1 1/8	1	1 1/8	\$4 50	\$6 50
82	10 × 23	8 × 21	33	1	1 1/8	1	1 1/8	4 50	6 50
83	10 1/8 × 30 1/8	8 × 28	40 1/4	1 1/8	1 1/8	1 1/8	1 1/8	4 50	6 50

Width of cross bars, 1 inch. Thickness of bars, 5/8 inch.

ELECTROTYPE CHASES.

Size Number.	Outside Measurement. Inches.	Inside Measurement. Inches.	Price of Chase.
84	13 × 17	10 × 14	\$5 70
85	15 × 21	12 × 18	5 70

Width of side and end bars, 1 1/2 inches. Thickness of bars, 5/8 inch.

Compute cost of Electrotpe chases same as for Poster, adding for extra stock.

Minimum price, \$5 70.

See Poster list for figuring measurements ending in fractions.

CAST IRON CHASES.

These are Finished Inside.

Outside Measure.	Price, each.	Outside Measure.	Price, each.	Outside Measure.	Price each.
6 × 7	\$0 45	10 × 24	\$1 50	12 × 33	\$2 25
6 1/2 × 8 1/4	0 50	10 × 25 1/2	1 65	13 3/4 × 20 1/2	1 75
6 × 18	1 20	10 × 28	1 75	14 × 16	1 40
8 × 10	0 80	11 × 16	1 30	14 × 18	1 75
9 × 12	1 00	10 1/2 × 14 1/2	1 25	14 3/4 × 19 1/4	1 80
8 1/2 × 14	1 10	12 × 14	1 20	15 × 24	2 00
8 × 20	1 30	12 × 15	1 30	16 × 19	1 90
8 × 24	1 40	12 × 18	1 40	17 × 22	1 75
8 × 28	1 60	12 × 26	1 80	17 × 22, with cross bar	2 25
10 × 14	1 20	12 × 30	1 90		

IRON SIDE AND FOOT STICKS.

Straight, 5/8 × 5/8, per inch \$0 04

Beveled, 5/8 to 1 inch × 5/8, per inch 0 05

Side sticks are made, unless otherwise ordered, 1/4 inch longer than the standard length of form, and foot sticks are made 1/4 inch shorter than standard width of form. If larger than 6-Point column rules are used, or columns wider than 13 ems Pica, allowance will have to be made.

EVERYTHING FOR THE PRINTER.

WROUGHT IRON CHASES FOR JOB PRESSES.

To insure a perfect fit on bed of press, we recommend customers to send sample chase with order after ascertaining that sample chase fits correctly.

- For 7 x 11, 8 x 12 and 9 x 13 presses \$5 00
- For 10 x 15 and 11 x 17 presses 5 50
- For 12 x 18 and 13 x 19 presses 6 50
- For 14 x 20, 14 x 22, and 14½ x 22 presses . . 7 25
- Minimum price of job press chase 5 00

CHASES FOR C. & P. GORDON PRESSES.

Inside Measure.	Cast Iron.	Cast Iron Screw.	Steel.	Steel Screw.
7 x 11 in.	\$1 00	\$1 50	\$2 70	\$4 00
8 x 12 in.	1 25	1 90	3 00	4 50
10 x 15 in.	1 50	2 25	4 50	6 75
12 x 18 in.	2 00	3 00	5 25	8 00
14 x 10 in.	2 50	3 75	5 75	8 50
14½ x 22 in.	3 00	4 50	6 00	9 00
13 x 19 in., special for 12 x 18 press			6 00	

CHASES FOR GALLY UNIVERSAL PRESSES.

	For 10x15 Press.	For 13x19 Press.	For 14x22 Press.
Cast iron	\$2 00	\$2 25	\$2 75
Wrought iron	5 50	6 50	7 25
*Steel skeleton	5 50	6 50	7 25

*Steel skeleton chases give more lock-up room, but do not add to printing capacity of press.

CHASES FOR PEERLESS PRESSES

	Cast Iron.	Steel.
For 8 x 12 press	\$1 25	\$3 00
For 9 x 13 press	1 50	3 50
For 10 x 15 press	1 50	4 50
For 11 x 17 press	2 00	5 00
For 14 x 20 press	2 50	5 75
For 14½ x 22 press	3 00	6 00

CHASES FOR JOB PRESSES.

Chases for job presses not shown in this catalogue can only be obtained by sending to the factory. Always send name of press and manufacturer's number, and specify whether chase is to be sent direct from the factory by express or freight. We can make new chases using old ones as a pattern at an advance over the prices for Chandler & Price Gordon Chases.

SPIDER CHASES FOR C. & P. JOB PRESSES.

These chases are invaluable for locking up small forms. They require but little furniture, and forms do not spring as is the case when locked up in a large chase.

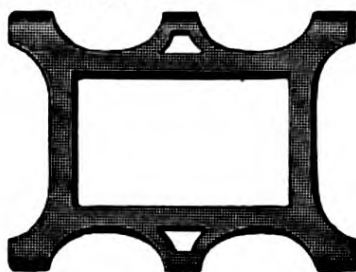

Inside Chase.	Price.
4 x 6 inches, for 7 x 11 press	\$1 00
4 x 6 inches, for 8 x 12 press	1 25
5 x 8 inches, for 10 x 15 press	1 50
6 x 9 inches, for 12 x 18 press	2 00
7 x 11 inches, for 14 x 20 press	2 50
8 x 12 inches, for 14½ x 22 press	3 00

STEREOTYPE CHASES.

The Best Made.

These stereotype chases are made in the most accurate manner, exactly type high, perfectly square and true. The side lock-up screw is attached to the side stick with a collar in such a manner as to enable the operator to lock up and unlock the chases with the wrench, drawing the side stick back and forward instantly, thus saving much time and avoiding the use of shooting stick and mallet, and consequent injury to the side stick. Prices, according to size, furnished on application.

Lock-up wrenches for stereotype chases, price \$2 50

FORM TRUCK.

Both the Form Trucks listed below are of malleable iron. The Union Form Truck is painted red.

The use of a form truck should be insisted on in every press room of any size, not only because it is a time saver, but because sliding chases along the floor is a source of frequent accidents.

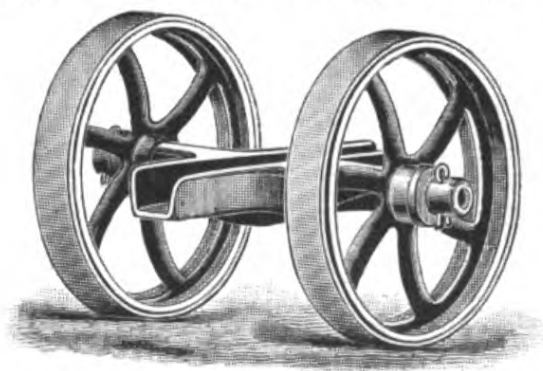

Iron tire \$3 00
 Union Form Truck, with rubber tire . . . 5 00

EVERYTHING FOR THE PRINTER.

HAND ROLLERS.

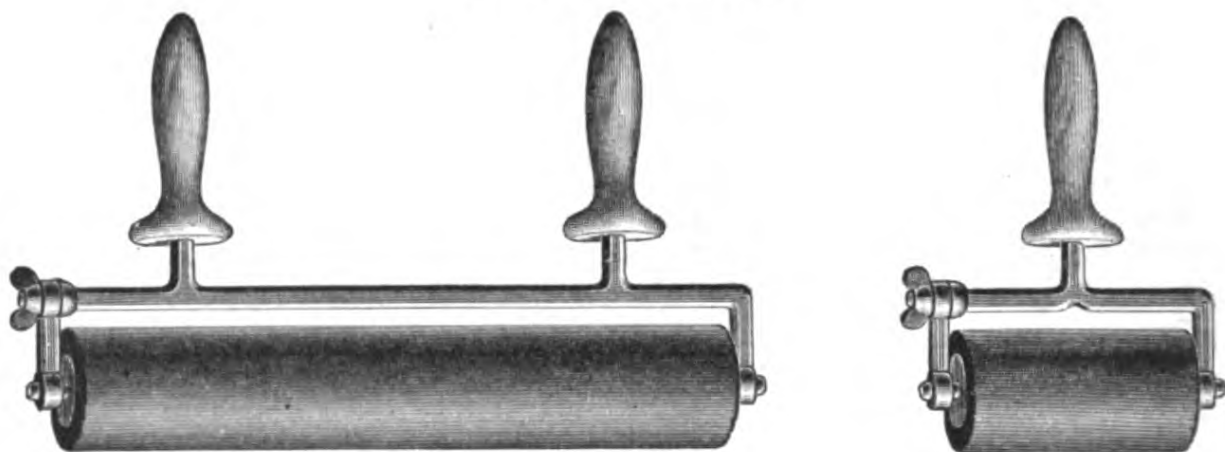

The frames of Nos. 1 to 7 are of wrought iron, the other frames of malleable iron. When complete rollers are ordered, we furnish them with the best roller composition. There is no economy in cheap roller composition.

	Number of Handles.	Frame with Stock.	Extra Stocks, each.	Complete with Com-position.	No.	Number of Handles.	Frame with Stock.	Extra Stocks, each.	Complete with Com-position.	
6 in.	1	\$1 25	\$0 40	\$1 75	1.	19½ in.	1	\$2 75	\$0 95	\$4 25
8 in.	1	1 25	0 40	1 85	2.	22½ in.	1	3 00	1 00	5 00
10 in.	1	1 50	0 50	2 00	3.	26½ in.	1	3 50	1 10	5 75
12 in.	1	1 75	0 60	2 55	4.	31½ in.	1	4 00	1 25	6 25
14 in.	2	2 00	0 70	3 00	4½.	36½ in.	1	4 50	1 40	6 75
16 in.	2	2 25	0 80	3 45	5.	39½ in.	1	4 65	1 45	7 25
18 in.	2	2 50	0 90	3 90	5½.	41½ in.	1	4 80	1 50	7 50
19½ in.	2	2 65	0 95	4 15	6.	44½ in.	1	5 00	1 55	8 00
					7.	48½ in.	1	5 50	1 70	8 50

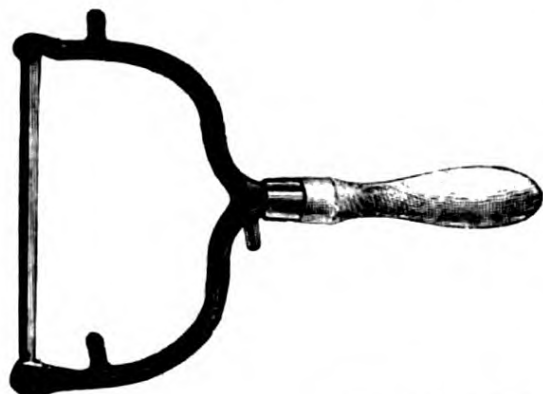

PROOF ROLLERS.

Malleable iron frame, wooden core and handle.

	Frame and Core.	Roller Complete.
6-inch	\$1 00	\$1 50
8-inch	1 05	1 60
10-inch	1 10	1 75
12-inch	1 25	2 00

STEEL ROLLER SUPPORTERS.

The best bearers yet devised for job presses. They only take up a quarter of an inch of the inside space of a chase, ease the pressure of the rollers on the form, prevent over-inking, equalize the impression, and save the rollers from cutting, as they are ¾-inch wide on top.

	Per pair.
For 5 × 9 chase	\$0 35
For 7 × 11 chase	0 40
For 8 × 12 chase	0 45
For 10 × 15 chase	0 50
For 11 × 17 chase	0 60
For 13 × 19 chase	0 75
For 14 × 20 chase	0 90
For 14½ × 22 chase	0 90

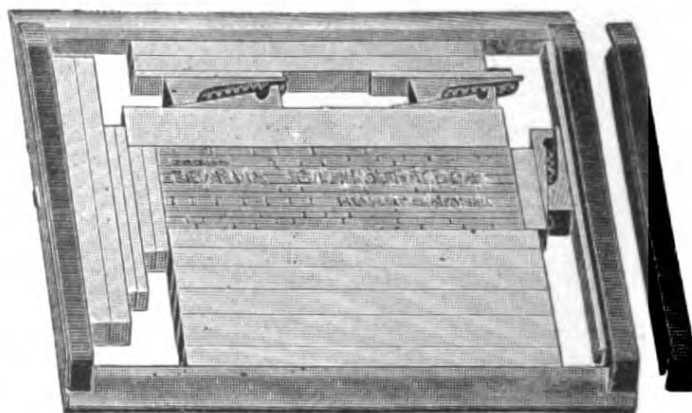

BRUCE TYPE FOUNDRY, 13 CHAMBERS STREET, NEW YORK.

EVERYTHING FOR THE PRINTER.

UNION TABLETING APPARATUS.

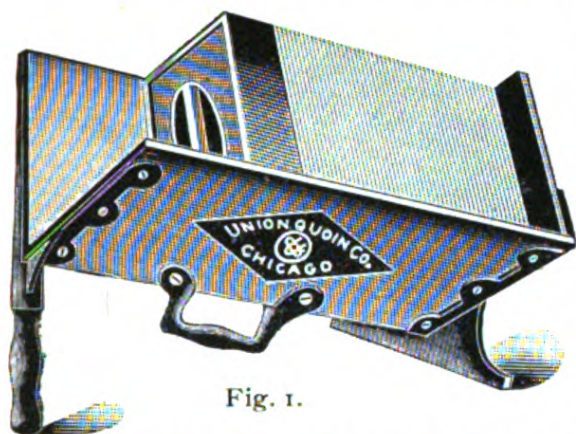

Fig. 1.

In this apparatus paper is held for padding without the use of screws or clamps. The trough (Fig. 1) is V-shaped, and is held at an angle which holds the paper snugly against the sides and the iron base-plate, which forms the bottom of the trough when it is tilted up. The paper in the trough is held under pressure by a heavy iron weight or brick; the trough is tilted up, and is lifted away, leaving the iron base-plate, paper and iron brick as in Fig. 2. The advantage this method has over the

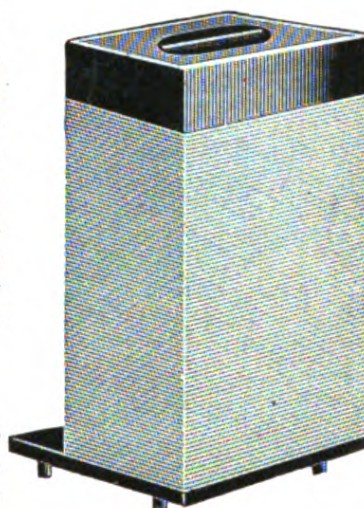

Fig. 2.

tablet presses using clamps is that, by buying extra base-plates and iron bricks, an unlimited number of piles of paper may be put up without waiting for the drying of the cement; thus the capacity of this apparatus surpasses that of other apparatus used for a like purpose, and is equally as well adapted for use in both large and small establishments.

- Complete, with trough, base-plate and hollow iron brick, size $8\frac{1}{2} \times 8\frac{1}{2} \times 18$ inches; capacity, 6000 sheets . . . \$7 50
- Extra iron bricks, hollow, each 2 00
- Extra iron bricks, solid, each 3 00
- Extra iron base-plates, each 0 75

COTT'S IMPROVED TABLET HOLDER AND CLAMP,



for straightening up and clamping sheets of paper while being glued for tablets. Will hold any quantity up to 3000 sheets of paper, and any size from $2\frac{1}{2} \times 2\frac{1}{2}$ to $8\frac{1}{2} \times 14$ inches.

With an additional clamp and larger press boards almost any size of work can easily be handled.

Accommodates all sizes of commercial stationery and admits of their being glued on one or both sides.

Offices doing a good-sized business should always order one or more extra clamps and sets of boards.

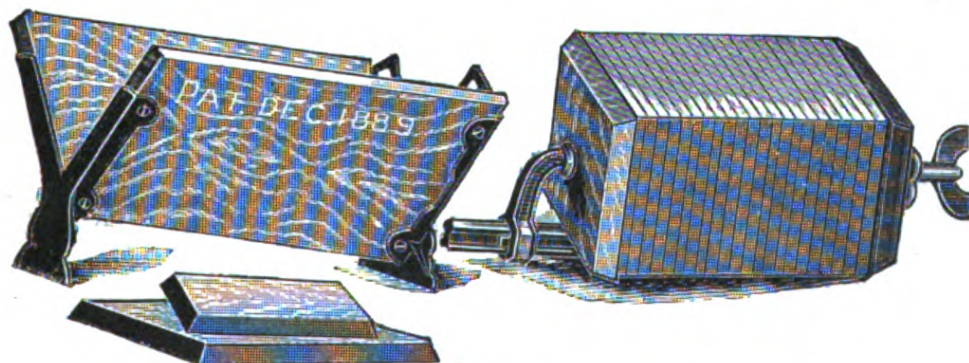

- Tablet holder and clamp, with set of four press boards \$3 25
- Extra clamp and four press boards 1 60
- Extra clamp without press boards 1 25

BRUCE TYPE FOUNDRY, 13 CHAMBERS STREET, NEW YORK.

EVERYTHING FOR THE PRINTER.

BINGHAM & RUNGE LIQUID PADDING GLUE.

Made in Red, Purple, Green and Colorless.

The Bingham & Runge Padding Glue was the first put on the market, and it has always maintained its reputation. The best materials are used in its composition, and on this account it does not get rancid. A quart will cement about 100,000 sheets of note size.

Half-Pints	\$0 35	Quarts	\$1 00
Pints	0 60	Gallons	3 75

LIQUID CEMENT BRUSH.

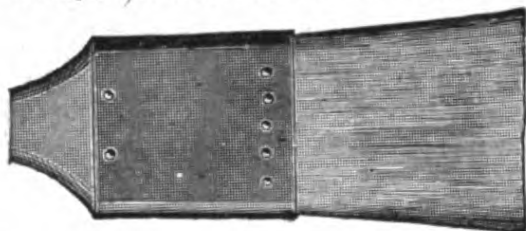

Made of French bristles, flat and double thick.

1 inch	\$0 30	2 inch	\$0 55
1 1/2 inch	0 40	3 1/2 inch	0 75



BINGHAM & RUNGE HERCULES ELASTIC PADDING GLUE.

An elastic, tough, quick-drying preparation, which is applied hot after melting in an ordinary glue pot, and, while entailing more labor, gives better results than the liquid glue. Does not adhere to the edges of sheets as they are removed from the pad, thus preventing tearing of pages in invoice and letter copying books. The color is bright red. Put up in pails, with directions for use on each.

5 pounds in pails . . . \$1 50 | 10 pounds in pails . . . \$3 00



PAPER COUNTER.

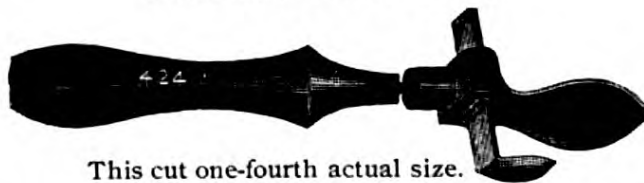

This cut one-fourth actual size.

To make ready for use in pad work, count out number of sheets wanted by hand, on top of which place the plate, then draw the stab up firmly against the paper. The screw in handle holds the stab in place. To operate, place plate on top of lot to be counted and push stab into paper, bearing down at same time.

Price \$0 75

GLUE POT.



1 quart, each \$0 90
2 quarts, each 1 20

TABLET KNIFE.



Made specially for separating pads; extra thin and strong.

Price \$0 50

EVERYTHING FOR THE PRINTER.

HERCULES LIQUID OVERLAY.

A substitute for paper overlays, giving a finer, quicker make-ready, and saving lots of time and tedious work. It is put on thinly with a camel's-hair brush, and the first application should be allowed to dry before putting on another, if the first is not heavy enough. It dries very quickly. If the Liquid Overlay is put on too thickly, the overlay is reduced by scraping it with fine emery cloth.

Each pressman should have an independent supply in a small phial suitable for carrying in the vest pocket.

4-ounce bottle, net \$1 25
 8-ounce bottle, net 2 00

Full directions with each bottle.



“BENTROVATO.”

[TRADE MARK.]

Dispels Electricity from Paper on Printing Presses.

A chemical fluid preparation which, applied in a small quantity to the tympan sheet by means of a sponge, cloth or cotton waste, effectually dispels the electricity generated in cylinder presses—a difficulty which results in serious losses to printers.

In all offices where there is a tendency toward this trouble, a bottle of “Bentrovato” will prove as valuable as the proverbial “stitch in time.”

“Bentrovato” is used in a majority of the larger printing offices throughout the United States.

American Type Founders' Co.: Please send me at once by American Express one bottle of “Bentrovato.” I should not like to be without it, even if it cost \$10 per bottle. Our devil knocked over the first bottle you sent us. I bought it with no faith, simply because I was willing to try anything. Our paper was as if possessed by ten thousand devils. The trouble ended at once and completely with the use of the “Bentrovato.”—**WALTER B. SHEPPARD**, publisher of the *Pan Yan Democrat* (founded in 1818).

Per bottle, net \$0 50



INKOLEUM.

A liquid preparation of world-wide fame for reducing and refining printing inks without impairing the color. It makes intractable inks work smoothly on disks, cylinders and rollers, and, mixed with caked inks, makes them useful again. Handy to have in the press room, as it is invaluable in cases of emergency.



Per bottle, half pound \$0 50

BRUCE TYPE FOUNDRY, 13 CHAMBERS STREET, NEW YORK.

EVERYTHING FOR THE PRINTER.

CHESAPEAKE ECONOMY COMPOUND.

The Effective Ink Reducer for both Lithographic and Letter-press Inks.



IT IS PURE.—Chesapeake Economy Compound is absolutely free from mineral petroleum products or acids of any kind, and is perfectly safe. Varnishes may be added, if required.

IT HELPS INKS.—Any kind or color of ink mixed with Chesapeake Economy Compound will not dry on forms or rollers, and will not skin when exposed to the air. Upon being mixed with ink, Economy Compound becomes thoroughly identified with it, and with less weight of ink a solid, sharp print is obtained. Inks mixed with Economy Compound will cover 30 per cent. more paper than if used without it.

IT PREVENTS TROUBLE.—Coated and surface papers will not pull if printed with ink mixed with Economy Compound, and the use of the Compound tends to prevent off-set and to make inks dry quicker on paper. It is not necessary, as a rule, to wash up rollers at night when inks are mixed with Economy Compound, as the inks will not dry on rollers. Economy Compound keeps lithographic stones in good condition, and inks mixed with it lift well from the stone.

1-pound cans	\$0 75
5-pound cans	3 25
10-pound cans	6 00
25-pound cans	13 75
50-pound cans	25 00

EUREKA TYPE WASH.



The most effective powder preparation for removing ink from type rollers and plates. Does not injure brushes, corrode type, nor hurt the hands. Directions on every package. While its action is gentle, it is quite as effective for cleaning as the most powerful lye. One pound of powder will make eight gallons of washing fluid.

1-pound cans, each	\$0 20
5-pound cans, each	0 75
10-pound cans, each	1 25
50-pound tubs, each	5 00

BRUCE TYPE FOUNDRY, 13 CHAMBERS STREET, NEW YORK.

EVERYTHING FOR THE PRINTER.

BURBANK'S EMBOSSING COMPOSITION.

This is an approved and satisfactory liquid chemical preparation for making counter dies for embossing, which, after exposure for a few minutes to light and air, hardens into a stone-like substance, making a perfect counterpart.

It is easily applied, according to directions printed on every can, and greatly simplifies and cheapens the process of embossing.

Price, net \$0 75



**BURBANK'S
"PRACTICAL GUIDE TO
EMBOSSING."**

This book explains lucidly and gives directions for several processes of embossing. It is the standard work on the subject.

Price, net \$1 00

WHITESON'S EMBOSSING COMPOSITION.



Shows exact size of cake.

This differs materially from other substances used for the same purpose, having among its ingredients certain chemicals which are affected only by heat. It can be readily softened by immersing in hot water. Will harden in three to five minutes, giving ample time to take impression and trim up die. Composition is of stone-like hardness, but not brittle, forming a most effective medium for forcing the paper or cardboard into the interstices of the die. *It can be remelted and used any number of times.*

- No. 1. For light work, per cake \$1.00
- No. 2. For heavy work, per cake 1 00

BRUCE TYPE FOUNDRY, 13 CHAMBERS STREET, NEW YORK.

EVERYTHING FOR THE PRINTER.

BRONZING MITTEN.



A convenient appliance for bronzing. Made from sheep's wool, with strong cloth back, and is impervious to bronze.

Each \$0 50

ELM CITY BRONZING PAD.



This has become an article of necessity in the press room. Saves time and bronze, and insures clean work.

Large, 2½×6 inches \$2 50
 Small, for light work, 2½ inches square 1 50

ADAMSON DISK COVER.

We have sold some hundreds of these useful Disk Covers, and none have been returned. Recommended as savers of ink and time, and approved by all purchasers.

Makes Copying Inks Work Easy.

Cold iron and copying inks repel each other. To avoid trouble, slip an Adamson Disk Cover over your disk. It is made of special cloth, lined with rubber. Iron dries the ink, deadens it, wastes it. The cloth disk gives good distribution, becomes saturated with ink like a stamp pad, and saves 50 per cent. of ink. When job is done, lift off disk cover. Saves washing time, and all the ink in cover is available the next time you use it. In ordering send the exact size of ink disk.

Owing to the limited space between edge of disk and chase-latch, these disks cannot be used on Golding Jobber and Pearl Presses.

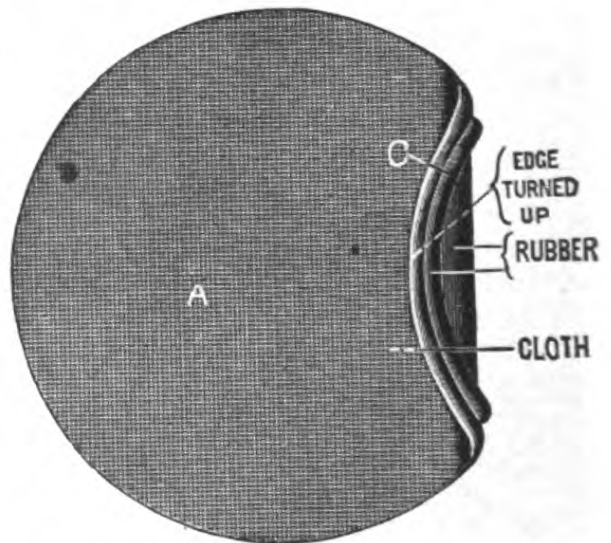

For press 7×11 inches, net \$1 50
 For press 8×12 inches, net 1 50
 For press 9×13 inches, net 1 50
 For press 10×15 inches, net 2 00
 For press 11×17 inches, net 2 00
 For press 12×18 inches, net 2 50

For press 13 ×19 inches, net . . . \$2 50
 For press 14 ×20 inches, net . . . 3 00
 For press 14½×22 inches, net . . . 3 00

Send exact size of disk when ordering. Directions with each Disk Cover.

BRUCE TYPE FOUNDRY, 13 CHAMBERS STREET, NEW YORK.

EVERYTHING FOR THE PRINTER.

PRINTING INKS.

These Inks are made by one of the most extensive Ink manufacturers in the world, and have a world-wide reputation for quality and uniformity. We use them exclusively on our own specimen printing. Inks for special work and to match all colors furnished to order expeditiously.

SMALLEST PACKAGES SOLD.

News Ink in packages as per Price List below.

2 lb.—Inks listed at 25 cents per lb. ½ lb.—Inks listed at 75 cents per lb.
 1 lb.—Inks listed at 50 cents per lb. ¼ lb.—Inks listed at \$1 50 per lb. and over.

N. B.—All Inks listed at \$1.50 and over supplied in ¼-lb. tubes if so ordered, but at a lesser discount than is allowed on Inks sold in cans.

SUPERIOR NEWS INKS.

	5 and 10 lb. cans.	28 and 56 lb. cans.	112 lb. barrels.	224 lb. barrels.	450 lb. barrels
For hand presses, per lb.	\$0 20	\$0 15	\$0 13	\$0 12	\$0 12
For flat-bed presses, "	0 18	0 14	0 13	0 12	0 12
For perfecting presses, "			0 13	0 12	0 12

BLACK INKS.

	Per lb.		Per lb.
Engraver's Wood-cut Proof Black	\$8 00	Union Black, I, job	\$1 50
Extra Fine Union Black, E, for half-tones	5 00	Insurance Policy Black	1 00
Extra Fine Union Black, E, cut and job	5 00	Columbian Black, H, for half-tones	1 00
Fine Union Black, F, for half-tones	3 00	Fine Book and Job, K	1 00
Fine Union Black, F, cut and job	3 00	Brilliant Black, L, job	0 75
Gloss Black	2 00	Brilliant Black, L, book	0 75
Fine Cut, G, for half-tones	2 00	Job Ink, M	0 50
Fine Job and Cut, G	2 00	Book Ink, M	0 50
Union Black, I, for half-tones	1 50	Book, Special	0 35
		Book Ink, N	0 25

SPECIAL BLACK INKS.

Fast Lustra Black, for printing line and half-tone cuts, with type, on ordinary news paper on the fastest web presses (smallest quantity sold, 28 lbs.)	\$0 50
Lustra Black, for printing half-tones, with type and line cuts, on cheap papers on perfecting presses, speed about 5000 per hour (smallest quantity sold, 28 lbs.)	0 45
Niagara Black, for printing half-tones, with type and line cuts, on cheap papers on flat-bed presses (smallest quantity sold, 10 lbs.)	0 40

BLUE- AND GREEN-BLACK INKS.

Bronze Blue-Black, light	\$2 50	Blue-Black, dark	\$1 50
Bronze Blue-Black, medium	2 00	Fine Green-Black	2 00

SPECIAL FAST-PRESS COLORS.

These are for use on colored supplements of newspapers printed on the fastest web presses. Smallest quantity sold, 28 lbs.

Fast-press Red	\$1 25	Fast-press Green	\$1 00
Fast-press Blue	1 00	Fast-press Yellow	0 85

BROWN INKS.

Brown Lake	\$4 00	Gloss Brown	\$3 00	Ochre	\$1 00
Photographic Brown	3 00	Velvet Brown	2 50	Poster Brown, dark	0 50
Virginia Brown	3 00	Terra di Sienna	2 00	Poster Brown, light	0 50
Bismarck Brown	3 00	Mahogany Brown	2 00		

BRUCE TYPE FOUNDRY, 13 CHAMBERS STREET, NEW YORK.

EVERYTHING FOR THE PRINTER.

RED INKS.

	Per lb.		Per lb.		Per lb.
Madder Lake	\$10 00	Claret Color	\$5 00	Brilliant Red, me-	
Geranium Carmine,		Nassau Lake	4 50	dium, Lake shade .	\$2 00
oo	10 00	Scarlet Lake	4 00	Brilliant Red, light .	1 00
Geranium Carmine,		Rose Lake, dark	4 00	Paris Lake	2 50
I	8 00	Rose Lake, medium	3 00	Hamburg Red	2 50
Geranium Lake,		Rose Lake, light	3 00	Label Red	2 00
dark	5 00	Deep Cherry	4 00	Chinese Vermilion	2 00
Geranium Lake,		Crimson Lake	4 00	Brilliant Lake, B	1 50
medium	5 00	Carmine Vermilion	4 00	Brilliant Lake, G	1 50
Geranium Lake,		Gloss Red	3 00	Deep Red	1 50
light	5 00	Antique Red (for old-		Granat Vermilion	1 00
Bronze Carmine	5 00	style red and black		Poster Red	0 50
Bronze Red	4 00	effects)	3 00	Poster Orange	0 50
Levantine Red	5 00	Brilliant Red, dark	3 00		

BLUE INKS.

Blue Lake, dark	\$5 00	Imperial Blue	\$3 00	Brussels Blue	\$2 50
Blue Lake, light	5 00	Gloss Blue	3 00	Oriental Blue	2 50
Peacock Blue	4 00	Bronze Blue, No. 1	2 50	Marine Blue	2 00
Milori Blue	3 00	Bronze Blue, No. 2	2 50	Label Blue	2 00
Ultramarine, dark	3 00	Deep Br'ze Blue, No. 1	2 50	Deep Blue	1 50
Ultramarine, light	1 50	Prussian Blue	2 50	Poster Blue	0 50

GREEN INKS.

Brilliant Green, light	\$5 00	Bronze Green	\$4 00	Silk Green, light	\$1 50
Brilliant Green, deep	5 00	Green Lake	3 00	Olive Green	2 00
Victoria Green, dark	5 00	Gloss Green	3 00	Poster Green, light	0 50
Victoria Green, light	4 00	Silk Green, dark	2 00	Poster Green, dark	0 50
Viridin Blue	5 00	Silk Green, medium	2 00		

YELLOW INKS.

Chrome Yellow, deep	\$2 00	Zinc Yellow	\$2 00	Label Yellow	\$2 00
Chrome Yellow, light	2 00	Persian Yellow	2 00	Yellow, medium	1 00
Chrome Orange	2 00	Sulphur Yellow, dark	2 00	Poster Yellow	0 50

PURPLE INKS.

Violet Lake, reddish	\$10 00	Brilliant Violet	\$4 00
Violet Lake, bluish	8 00	Violet No. 1	4 00

GOLD INK.

Pale Gold	\$5 00	Rich Gold	\$5 00
---------------------	--------	---------------------	--------

WHITE INKS.

Ex. Fine Body White (prints white)	\$1 50	Fine White, for tints	\$1 00
Poster White	\$0 50		

TINT INKS.

Any shade (twelve shades kept in stock, as per Ink Specimen Book)	\$1 00
---	--------

SILK INKS.

Silk Amaranth	\$5 00	Silk Dark Blue	\$5 00
Silk Red	5 00	Silk Violet	5 00
Silk Grass Green	5 00	Silk Purple	5 00
Silk Blue Green	5 00	Silk Dark Purple	5 00
Celestial Silk Blue	5 00	Silk Light Brown	5 00

COPYABLE INKS.

Purple	\$5 00	Red	\$5 00	Scarlet	\$5 00
Black	5 00	Blue	5 00	Green	5 00

EVERYTHING FOR THE PRINTER.

GLOSS INKS.

Per lb. Gloss Red \$3 00 Gloss Blue 3 00	Per lb. Gloss Green \$3 00 Gloss Brown 3 00	Per lb. Gloss Black \$2 00
--	---	---

TYPEWRITER-EFFECT INKS.

Blue Typewriter \$2 50 Purple Typewriter 2 50	Green Typewriter \$2 50
--	-----------------------------------

THREE-COLOR PROCESS INKS.

Three-color Process Red \$4 50 Three-color Process Blue 4 00	Three-color Process Yellow \$3 00
---	---

REDUCING VARNISHES.

FOR REDUCING COLORED AND FINE BLACK INKS.

Pure Linseed, bleached, A, very soft Pure Linseed, bleached, B, soft Pure Linseed, bleached, C, medium	Per lb. \$0 50 0 55 0 60	Per gal. \$2 25 2 25 2 50
--	-----------------------------------	------------------------------------

ORDINARY, FOR REDUCING BLACK INKS.

Ordinary	\$0 30	\$1 00
--------------------	--------	--------

GLOSS VARNISHES.

Transparent Gloss Varnish, for mixing into inks Body Gloss Varnish, for printing over black and colored inks	Per lb. \$1 50 1 50
---	---------------------------

DRYERS.

Body Dryer, will not reduce consistency or body of inks	\$1 50
Fluid Dryer	1 50

NOTE—From one to two per cent. of above dryers can be safely used in colored inks, and from three to eight per cent. in black inks.

BRONZE INKS.

Bronze Carmine . . . \$5 00	Bronze Green . . . \$4 00	Bronze Blue No. 1 . . \$2 50
Bronze Red 4 00	Deep Br'ze Blue No. 1 . 2 50	Bronze Blue No. 2 . . 2 50

BRONZE SIZE.

Yellow	\$1 50
White, for silver bronzes	1 50

BRONZE POWDERS.

Extra Fine Brilliant Rich Gold No. 1 Extra Fine Brilliant Pale Gold No. 1 Extra Fine Brilliant No. 1, Crimson, Copper, Fire or Green Extra Brilliant Rich "Electra" Gold No. 2 Extra Brilliant Pale "Electra" Gold No. 2 Brilliant Pale Gold No. 3 Brilliant Rich Gold No. 3 Brilliant No. 3, Crimson, Copper, Fire or Green Rich or Pale Gold, grade A Rich or Pale Gold, grade B Silver No. 1 Silver No. 2 Silver No. 3 Aluminum Patent Bronzes (Light Blue, Dark Blue, Blue-Green, Deep Green, Sea- Green, Yellow-Green, Amaranth and Violet)	Per oz. \$0 40 0 45 0 45 0 35 0 40 0 25 0 25 0 50 0 40 0 25 0 40	Per lb. \$3 50 4 50 4 50 3 00 4 00 2 00 2 00 3 00 1 00 1 25 5 00 3 50 2 50 4 00
---	---	---

BRUCE TYPE FOUNDRY, 13 CHAMBERS STREET, NEW YORK.

USEFUL INFORMATION FOR PRINTERS

HOW TO ESTIMATE.

To ascertain the quantity of body type required for a publication, find the number of square inches and divide the same by four, and the quotient will be the approximate weight of type required; but, as it is impossible to set the cases entirely clear, it is necessary to add 25 per cent. to the weight of large fonts, and 33½ per cent. to small fonts, to allow for dead letter.

HOW TO ORDER SORTS.

In ordering sorts always inclose a metal cap *H* and lower-case *m* of the type you wish to match, and plainly state the quantity of each character required. Be sure and inclose sample before sealing envelope inclosing order. Better put sample in a small envelope. Order every article by the *exact name and number* given in the specimen book. Variations from the book names frequently cause error and delay. *Do not mutilate* a specimen book. It does not help us to receive printed specimens taken from our specimen books. In ordering, write each item on a separate line. Orders written in long paragraphs invite error. Separate the order from the accompanying letter. It will save time.

TYPE STANDARDS.

The following is the standard adopted by the International Typographical Union. The basis of measurement is the lower-case alphabet, from a to z inclusive, and the ems used are the same body as the type measured:

	EMS		EMS
4½ Point	18	8 Point	14
5 "	17	9 "	13
5½ "	16	10 "	13
6 "	15	11 "	13
7 "	14	12 "	13

AMERICAN POINT SYSTEM.

The following table gives the names of the old bodies and their new designation by points:

3½ Point	Brilliant.
4½ "	Diamond.
5 "	Pearl.
5½ "	Agate.
6 "	Nonpareil.
7 "	Minion.
8 "	Brevier.
9 "	Bourgeois.
10 "	Long Primer.
11 "	Small Pica.
12 "	Pica.
14 "	2-line Minion or English.
15 "	3-line Pearl
16 "	2-line Brevier.
18 "	Great Primer.
20 "	2-line Long Primer or Paragon.
22 "	2-line Small Pica.
24 "	2-line Pica.
28 "	2-line English.
30 "	5-line Nonpareil.
32 "	4-line Brevier.
36 "	2-line Great Primer.
40 "	Double Paragon.
42 "	7-line Nonpareil.
44 "	4-line Small Pica or Canon.
48 "	4-line Pica.
54 "	9-line Nonpareil.
60 "	5-line Pica.
72 "	6-line Pica.

RELATIVE PROPORTION OF TYPE BODIES.

Table showing the number of ems of different bodies contained in 1000 ems space of any given body. Also the weight and space occupied by 1000 ems of any body. Also the number of ems of any body, and the number of inches, in one pound.

1000 EMS OF	3½ POINT	4½ POINT	5 POINT	5½ POINT	6 POINT	7 POINT	8 POINT	9 POINT	10 POINT	11 POINT	12 POINT	WEIGHT	SQ. INCHES
3½ Point		605	490	405	341	250	192	151	122	101	85	10 oz.	2.36
4½ Point	1653		810	670	563	413	316	250	203	167	141	1½ lbs.	3.91
5 Point	2041	1235		827	695	510	391	309	250	207	174	1½ lbs.	4.82
5½ Point	2469	1493	1210		840	617	473	373	303	250	210	1½ lbs.	5.83
6 Point	2940	1780	1440	1192		735	563	445	360	297	250	1½ lbs.	6.94
7 Point	4000	2420	1960	1620	1364		766	604	490	405	340	2½ lbs.	9.44
8 Point	5224	3160	2560	2116	1780	1306		790	640	529	445	3½ lbs.	12.35
9 Point	6612	4000	3240	2680	2252	1653	1266		810	670	564	4½ lbs.	15.62
10 Point	8164	4940	4000	3308	2780	2041	1563	1236		828	696	5 lbs.	19.29
11 Point	9876	5972	4840	4000	3360	2469	1891	1492	1210		840	6½ lbs.	23.30
12 Point	11756	7112	5760	4760	4000	2939	2250	1778	1440	1190		7½ lbs.	27.77
Ems in one lb.	1600	960	790	650	550	400	300	240	200	160	140		3.75
Ems in square inch	422½	256	207½	171½	144	105½	81	64	51½	42½	36	4½ oz.	

BRUCE TYPE FOUNDRY, 13 CHAMBERS STREET, NEW YORK.

EVERYTHING FOR THE PRINTER.

NUMBER OF EMS IN ONE POUND OF TYPE.

Two by two inches (four square inches) solid type weighs approximately one pound :

5 Point 829	7 Point 423	10 Point 207
5½ Point 685	8 Point 324	11 Point 171
6 Point 576	9 Point 256	12 Point 144

NUMBER OF EMS IN SQUARE INCHES OF TYPE.

[Copyrighted by D. Ramaley.]

8Q. IN.	6 PT.	7 PT.	8 PT.	9 PT.	10 PT.	11 PT.	12 PT.	8Q. IN.	6 PT.	7 PT.	8 PT.	9 PT.	10 PT.	11 PT.	12 PT.
1 . . .	144	106	81	64	52	43	36	29 . . .	4176	3074	2349	1856	1508	1249	1044
2 . . .	288	212	162	128	104	86	72	30 . . .	4320	3180	2430	1920	1560	1292	1080
3 . . .	432	318	243	192	156	129	108	31 . . .	4464	3286	2511	1984	1612	1335	1116
4 . . .	576	424	324	256	208	172	144	32 . . .	4608	3392	2592	2048	1664	1378	1152
5 . . .	720	530	405	320	260	215	180	33 . . .	4752	3498	2673	2112	1716	1421	1188
6 . . .	864	636	486	384	312	258	216	34 . . .	4896	3604	2754	2176	1768	1464	1224
7 . . .	1008	742	567	448	364	301	252	35 . . .	5040	3710	2835	2240	1820	1507	1260
8 . . .	1152	848	648	512	416	348	288	36 . . .	5184	3816	2916	2304	1872	1550	1296
9 . . .	1296	954	729	576	468	387	324	37 . . .	5328	3922	2997	2368	1924	1593	1332
10 . . .	1440	1060	810	640	520	430	360	38 . . .	5472	4028	3078	2432	1976	1636	1368
11 . . .	1584	1166	891	704	572	473	396	39 . . .	5616	4134	3159	2496	2028	1679	1404
12 . . .	1728	1272	972	768	624	516	432	40 . . .	5760	4240	3240	2560	2080	1722	1440
13 . . .	1872	1378	1053	832	676	559	468	41 . . .	5904	4346	3321	2624	2132	1765	1476
14 . . .	2016	1484	1134	896	728	602	504	42 . . .	6048	4452	3402	2688	2184	1808	1512
15 . . .	2160	1590	1215	960	780	645	540	43 . . .	6192	4558	3483	2752	2236	1851	1548
16 . . .	2304	1696	1296	1024	832	688	576	44 . . .	6336	4664	3564	2816	2288	1894	1584
17 . . .	2448	1802	1377	1088	884	733	612	45 . . .	6480	4770	3645	2880	2340	1937	1620
18 . . .	2592	1908	1458	1152	936	776	648	46 . . .	6624	4876	3726	2944	2392	1980	1650
19 . . .	2736	2014	1539	1216	988	819	684	47 . . .	6768	4982	3807	3008	2444	2023	1696
20 . . .	2880	2120	1620	1280	1040	862	720	48 . . .	6912	5088	3888	3072	2496	2066	1728
21 . . .	3024	2226	1701	1344	1092	905	756	49 . . .	7056	5194	3969	3136	2548	2109	1764
22 . . .	3168	2332	1782	1408	1144	948	792	50 . . .	7200	5300	4050	3200	2600	2152	1800
23 . . .	3312	2438	1863	1472	1196	991	828	51 . . .	7344	5406	4131	3264	2652	2194	1836
24 . . .	3456	2544	1944	1536	1248	1034	864	52 . . .	7488	5512	4212	3328	2704	2236	1872
25 . . .	3600	2650	2025	1600	1300	1077	900	53 . . .	7632	5618	4293	3392	2756	2278	1908
26 . . .	3744	2756	2106	1664	1352	1120	936	54 . . .	7776	5724	4374	3456	2808	2320	1944
27 . . .	3888	2862	2187	1728	1404	1163	972	55 . . .	7920	5830	4455	3520	2860	2362	1980
28 . . .	4032	2968	2268	1792	1456	1206	1108	56 . . .	8064	5936	4536	3584	2912	2404	2016

NUMBER OF LEADS TO THE POUND.

Table showing the approximate number of 2-point and 3-point leads contained in a pound. For 1-point leads, multiply the 2-point columns by 2. For 1½-point leads, multiply the 3-point columns by 2. For 6-point slugs, divide 3-point columns by 2.

EMS LONG	2 POINT	3 POINT	EMS LONG	2 POINT	3 POINT	EMS LONG	2 POINT	3 POINT	EMS LONG	2 POINT	3 POINT
3	288	192	15	57	38	27	31	21	39	22	15
4	216	144	16	54	36	28	30	20	40	21	14
5	168	112	17	51	34	29	30	20	41	21	14
6	144	96	18	48	32	30	29	19	42	20	14
7	123	82	19	45	30	31	28	19	43	20	13
8	108	72	20	42	28	32	27	18	44	19	13
9	96	64	21	40	27	33	26	17	45	19	13
10	84	56	22	39	26	34	25	17	46	18	12
11	78	52	23	37	25	35	24	16	47	18	12
12	72	48	24	36	24	36	24	16	48	18	12
13	66	44	25	34	23	37	23	15	49	17	11
14	61	41	26	33	22	38	22	15	50	17	11

ROMAN NUMERALS.

I—1	VI—6	XI—11	XVI—16	XXX—30	LXXX—80	CCC—300	DCCC—800
II—2	VII—7	XII—12	XVII—17	XL—40	XC—90	CCCC—400	DCCCC—900
III—3	VIII—8	XIII—13	XVIII—18	L—50	C—100	D—500	M—1000
IV—4	IX—9	XIV—14	XIX—19	LX—60	CL—150	DC—600	
V—5	X—10	XV—15	XX—20	LXX—70	CC—200	DCC—700	

BRUCE TYPE FOUNDRY, 13 CHAMBERS STREET, NEW YORK.

EVERYTHING FOR THE PRINTER.

APPROXIMATE NUMBER OF WORDS IN A SQUARE INCH.

In calculating the number of pages a manuscript will occupy, these figures may be used:

	WORDS TO SQ. IN.		WORDS TO SQ. IN.
18 Point, solid	7	9 Point, leaded	21
14 Point, solid	11	8 Point, solid	32
12 Point, solid	14	8 Point, leaded	23
12 Point, leaded	11	7 Point, solid	38
11 Point, solid	17	7 Point, leaded	27
11 Point, leaded	14	6 Point, solid	47
10 Point, solid	21	6 Point, leaded	34
10 Point, leaded	16	5 Point, solid	69
9 Point, solid	28	5 Point, leaded	50

"Leaded," as here used, means an opening of lines with 2-point leads.

USEFUL IN ORDERING SORTS.

In ordering sorts *always* send a cap H and lower-case m of the font you wish to match. These letters should be sent, no matter what the characters are that you wish to purchase. The following table shows what each box in the type case will hold:

a c d i s m n h o u t r	boxes, each hold	2 pounds.
f b l v g y p w	boxes, each hold	15 ounces.
k j z x q and all figures	boxes, each hold	6 ounces.
e	box holds	3 pounds.
Caps and small caps	boxes, each hold	5 ounces.

TO PRINT CONSECUTIVE NUMBERS.

Orders to print consecutive numbers are received more or less frequently by every printing office, large or small. In the average office, to print the numbers 1 to 200 consecutively would be quite a task, and when undertaken in the ordinary way, with the

facilities usually at hand, the cost is so high that the customer usually concludes to get along with something else than printed numbers, and what might be a profitable job is lost to the office.

Suppose an order for two hundred reserved seat numbers from 1 to 200, six copies of each. It is not necessary to set up more than the units 1 to 0. These figures are to be set up, properly spaced, one above the other, as shown in column A of the table annexed.

A	B	C	D	E	F	G	H	I	K	L
1	11	21	31	41	51	61	71	81	91	01
2	22	32	42	52	62	72	82	92	02	12
3	33	43	53	63	73	83	93	03	13	23
4	44	54	64	74	84	94	04	14	24	34
5	55	65	75	85	95	05	15	25	35	45
6	66	76	86	96	06	16	26	36	46	56
7	77	87	97	07	17	27	37	47	57	67
8	88	98	08	18	28	38	48	58	68	78
9	99	09	19	29	39	49	59	69	79	89
0	00	10	20	30	40	50	60	70	80	90

One hundred and twenty impressions are taken on strips of cardboard cut to the required width. This done, gives the required number of units. Change the gauge pins in a manner to print the same form beside the printed figures to form the tens, as shown in column B of the table. Take twelve impressions of this form on twelve of the already printed strips. The next step is to change the form by taking the top figure (1) and place it at the bottom of the column, so the next impression on a strip of the first form will read as shown in column C of the table. We print again twelve strips of the first form. This change of the top figures, 2, 3, 4, 5, 6, 7, 8, 9 and 0, respectively, is repeated eight more times, shown in the table as columns D, E, F, G, H, I, K and L. From each change twelve impressions on the printed slips containing the first form must be made. This will finish the tens, and by changing the form to ten figure 1s and again moving the pins to the left for the space-width of the type, and printing six strips of each the former changes from B to L, gives the hundreds, or a continuous run of numbers from 1 to 199 in an edition of six copies. To obtain number 200, print upon the six strips left a figure 2 to head the 00 of column B. In assorting the numbers it will be found that each six copies of the heavy type cannot be used, but this small loss in stock is compensated many times by the advantage derived from the method.

EVERYTHING FOR THE PRINTER.

PROOFREADER'S MARKS.

- | | | |
|---|---|---|
| <p>X Change bad letter.
 ↓ Push down space.
 ↻ Turn.
 ✂ Take out (<i>delete</i>).
 ^ Left out; insert.
 ✚ Insert space.
 ∨ Even spacing.
 ⤵ Less space.</p> | <p>⊂ Close up entirely.
 ⊙ Period.
 / Comma.
 ⊙ Colon.
 ; Semicolon.
 ′ Apostrophe.
 ⌞ Quotation.</p> | <p>/ Hyphen.
 // Straigten lines.
 □ Move over.
 □ Em-quad space.
 /- One-em dash.
 /- Two-em dash.</p> |
| <p>¶ Paragraph.
 No ¶ No paragraph.
 <i>w. f.</i> Wrong font.
 Let it stand.
 <i>stet.</i> Let it stand.
 <i>tr.</i> Transpose.
 <i>Caps</i> Capital letters.
 <i>s. c.</i> Small caps.
 <i>l. c.</i> Lower case or small letters.
 <i>Ital.</i> Italics.
 <i>Rom.</i> Roman.</p> | | |

TABLE SHOWING THE AMOUNT OF PAPER REQUIRED
 for any job of from 50 to 5000 copies. No allowance is made for waste.

NO. OF COPIES REQUIRED.	2 TO THE SHEET		3 TO THE SHEET		4 TO THE SHEET		6 TO THE SHEET		8 TO THE SHEET		9 TO THE SHEET		12 TO THE SHEET		15 TO THE SHEET		16 TO THE SHEET		18 TO THE SHEET		20 TO THE SHEET		24 TO THE SHEET		32 TO THE SHEET		
	QUIRES	SHEETS	QUIRES	SHEETS	QUIRES	SHEETS	QUIRES	SHEETS	QUIRES	SHEETS	QUIRES	SHEETS	QUIRES	SHEETS	QUIRES	SHEETS	QUIRES	SHEETS	QUIRES	SHEETS	QUIRES	SHEETS	QUIRES	SHEETS	QUIRES	SHEETS	
50	1-1		0-17		0-13		0-9		0-7		0-6		0-5		0-4		0-4		0-3		0-3		0-3		0-3		0-2
100	2-2		1-10		1-1		0-17		0-13		0-12		0-9		0-7		0-7		0-6		0-5		0-5		0-5		0-4
200	4-4		2-19		2-2		1-10		1-1		0-23		0-17		0-14		0-13		0-12		0-10		0-09		0-09		0-7
250	5-5		3-12		2-15		1-18		1-8		1-4		0-21		0-17		0-16		0-14		0-13		0-11		0-11		0-8
300	6-6		4-4		3-3		2-2		1-14		1-10		1-1		0-20		0-19		0-17		0-15		0-13		0-13		0-10
400	8-8		5-14		4-4		2-19		2-2		1-21		1-10		1-3		1-1		0-23		0-20		0-17		0-17		0-13
500	10-10		6-23		5-5		3-12		2-15		2-8		1-18		1-10		1-8		1-4		1-1		0-21		0-21		0-16
600	12-12		8-8		6-6		4-4		3-3		2-19		2-2		1-16		1-14		1-10		1-6		1-1		1-1		0-19
700	14-14		9-18		7-7		4-21		3-16		3-6		2-11		1-23		1-20		1-15		1-11		1-6		1-6		0-22
750	15-15		10-10		7-20		5-5		3-22		3-12		2-15		2-3		1-23		1-18		1-14		1-8		1-8		1-0
800	16-16		11-3		8-8		5-14		4-4		3-17		2-19		2-6		2-2		1-21		1-16		1-10		1-10		1-1
900	18-18		12-12		9-9		6-6		4-17		4-4		3-3		2-12		2-9		2-2		1-21		1-14		1-14		1-5
1000	20-20		13-22		10-10		6-23		5-5		4-16		3-12		2-19		2-15		2-8		2-2		1-18		1-18		1-8
1250	26-1		17-9		13-1		8-17		6-13		5-19		4-9		3-12		3-7		2-22		2-15		2-5		2-5		1-16
1500	31-6		20-20		15-15		10-10		7-20		6-23		5-5		4-5		3-22		3-12		3-3		2-15		2-15		1-23
1750	36-11		24-8		18-6		12-4		9-3		8-3		6-2		4-22		4-14		4-2		3-16		3-1		3-1		2-8
2000	41-16		27-19		20-20		13-22		10-10		9-7		6-23		5-14		5-5		4-16		4-4		3-12		3-12		2-15
2500	52-2		31-18		26-1		17-10		13-1		11-15		8-17		7-0		6-13		5-20		5-5		4-9		4-9		3-7
3000	62-12		44-16		31-6		20-20		15-15		13-22		10-10		8-8		7-20		6-23		6-6		5-5		5-5		3-22
4000	83-8		55-14		41-16		27-19		20-20		18-13		13-22		11-3		10-10		9-7		8-8		6-23		6-23		5-5
5000	104-4		69-11		52-2		34-18		26-1		23-4		17-9		13-22		13-1		11-14		10-10		8-17		8-17		6-13

METRIC SYSTEM OF WEIGHTS AND MEASURES.

In use in all European countries except Great Britain and Russia. In use in Mexico and South America.

The Meter, unit of length, is nearly the ten-millionth part of a quadrant of a meridian, of the distance between equator and pole. The International Standard Meter is, practically, nothing else but a length defined by the distance between two lines on a platinum-iridium bar at 0° Centigrade, deposited at the International Bureau of Weights and Measures, Paris, France.

The Liter, unit of capacity, is derived from the weight of one kilogram pure water at greatest density, a cube whose edge is one-tenth of a meter, and, therefore, the one-thousandth part of a metric ton.

The Gram, unit of weight, is a cube of pure water at greatest density, whose edge is one-hundredth of a meter, and therefore the one-thousandth part of a kilogram and the one-millionth part of a metric ton.

One silver dollar weighs 25 grams, 1 dime = 2½ grams, 1 five-cent nickel = 5 grams.

THE METRIC SYSTEM SIMPLIFIED.

The following tables of the metric system of weights and measures have been simplified as much as possible by Mr. John Wilkes, of Nashville, Tenn., by omitting such denominations as are not in practical, everyday use in the countries where the system is used exclusively.

TABLES OF THE SYSTEM.

LENGTH.—The denominations in practical use are millimeters (mm.), centimeters (cm.), meters (m.), and kilometers (km.).

10 mm. = 1 cm.; 100 cm. = 1 m.; 1000 m. = 1 km.

A decimeter is 10 cm.

WEIGHT.—The denominations in use are grams (g.), kilos* (kg.), and tons (metric tons).

1000 g. = 1 kg.; 1000 kg. = 1 metric ton.

CAPACITY.—The denominations in use are cubic centimeters (c.c.), and liters (l).

1000 c.c. = 1 l.

A hectoliter is 100 l. (seldom used).

Relation of capacity and weight to length: A cubic decimeter is a liter, and a liter of water weighs a kilo.

APPROXIMATE EQUIVALENTS.

A meter is about a yard; a kilo is about 2 lbs.; a liter is about a quart; a centimeter is about ½ inch; a metric ton is about the same as a ton; a kilometer is about ½ mile; a cubic centimeter is about a thimbleful; a nickle weighs about 5 grams.

* Contraction for kilogram.

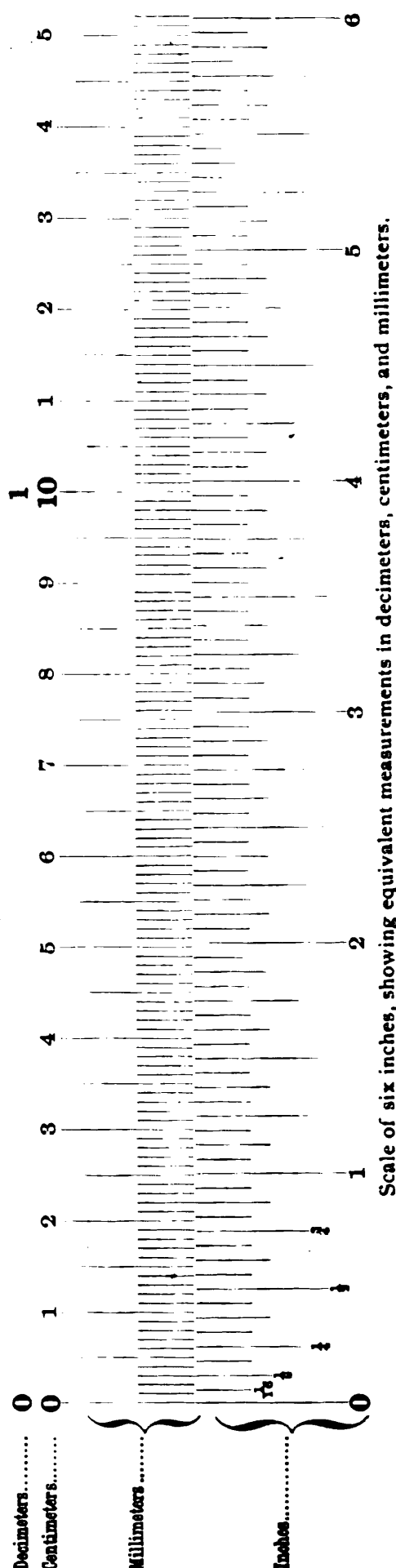



THE UNIVERSITY OF MICHIGAN
GRADUATE LIBRARY

DATE DUE

~~NOV 22 1991~~
~~NOV 22 1991~~
~~NOV 22 1991~~
NOV 22 1991

~~JUN 07 1992~~
~~JUN 07 1992~~
JUN 07 1992

~~OCT 2 1992~~
~~OCT 2 1992~~
NOV 16 1992

UNIVERSITY OF MICHIGAN



3 9015 02513 0124

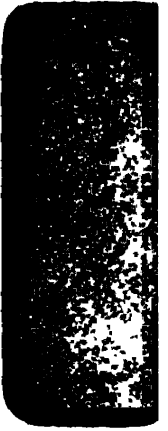

**DO NOT REMOVE
OR
MUTILATE CARD**



Y 11

