

# Cornell University Library

The original of this book is in  
the Cornell University Library.

There are no known copyright restrictions in  
the United States on the use of the text.

Cornell University Library  
**Z 250.A5**

Handy specimen book; specimens of type, b



3 1924 014 559 730

männ









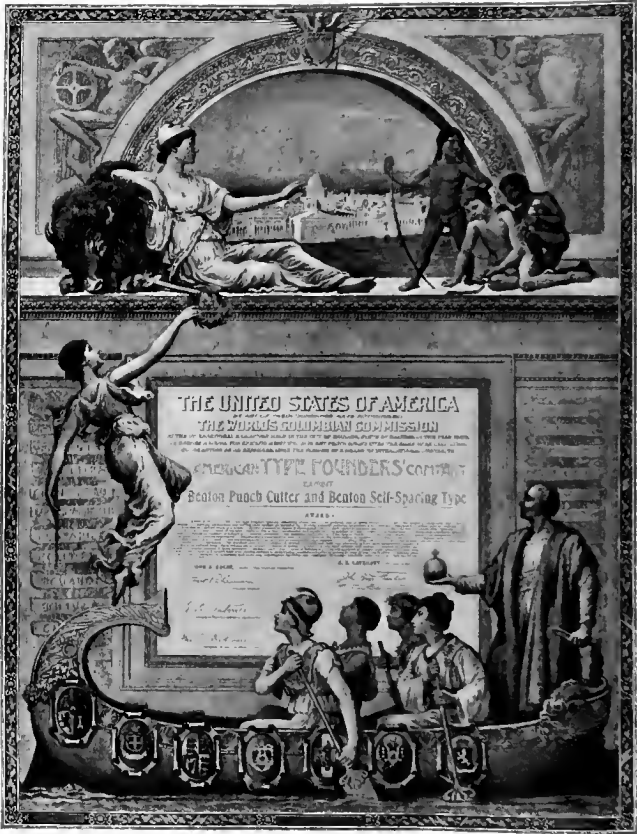





Handy  
Specimen  
Book

**Specimens of Type  
Borders & Ornaments  
Brass Rule, Wood Type, etc.**



Catalogue of Printing Machinery  
and Materials, Wood Goods, etc.



... American ...  
**Type Founders Company**

No. 45 N. Division St., corner of Ellicott  
Buffalo, New York

1897





---

## PREFACE.

---

*This book contains a very complete selection of the choicest and most approved Type and Borders made by this Company. Specimen Books usually show all that a Type foundry makes, but an examination of the contents of this book will convince the Printer that our selection excels the complete product of other Type foundries not only in design, originality and accuracy of the faces, but also in variety and completeness. The durability of our Type is assured by the use of the celebrated Copper Alloy Type Metal.*

*It is conceded that the Type made by this Company is the standard of excellence throughout the world. Every endeavor is made to advance that standard. Our Type embodies all the mechanical merits with a marked superiority in design—the chief merit of Type, without which it will not satisfy the public that pays the printer for good printing. No matter how much skill may be employed in composition and presswork, nor how good the paper and ink that are used in printing, if the design of the Type is inartistic and inferior the work will fail to be satisfactory. Our Type is therefore of superior value to the Printer, though pound for pound it may cost no more than Type of inferior design, and a printing office completely furnished with the products of this Company is worth more, for either use or sale, than when made up from the productions of incomplete Type foundries.*

*The Catalogue of Printing Machinery and Supplies at the end of this book is the most complete ever issued. As the largest purchaser of Printing Machinery and Materials in the world, this Company commands the best of everything for the Printer, and has unsurpassed facilities for meeting the requirements of printing offices, from the smallest to the most extensive.*

AMERICAN TYPE FOUNDERS COMPANY.

Buffalo, January, 1898.

---



# AMERICAN TYPE FOUNDERS COMPANY

## BRANCHES

BOSTON, 150 Congress Street  
NEW YORK, Rose and Duane Streets  
PHILADELPHIA, 606-614 Sansom Street  
BALTIMORE, Frederick and Water Streets  
BUFFALO, 45 N. Division Street, corner of Ellicott  
PITTSBURGH, 323 Third Avenue  
CLEVELAND, St. Clair and Ontario Streets  
CHICAGO, 139-141 Monroe Street  
CINCINNATI, 7-13 Longworth Street  
KANSAS CITY, 612 Delaware Street  
ST. LOUIS, Fourth and Elm Streets  
MINNEAPOLIS, 24-26 First Street, South  
SAN FRANCISCO, 405-407 Sansome Street  
LOS ANGELES, 205 W. Los Angeles Street  
PORTLAND, Second and Stark Streets  
DENVER, 1616-1622 Blake Street

# Index to Type Specimens

	PAGE		PAGE
ADVERTISING RULES	12	Bradley . . . . .	278, 279
Algebraic Signs	42	Bradley Extended . . . . .	281
Almanac Signs	43	Bradley Initials	279
Angular Quads . . . . .	10	Bradley Outline	280
Antique . . . . .	124, 125, 128	Brass Braces . . . . .	22
Antique No. 46 . . . . .	128	Brass Circles . . . . .	21
Antique Condensed No. 44 . . . . .	128	Brass Column Rules . . . . .	12
Antique Condensed No. 45 . . . . .	130	Brass Dashes . . . . .	20
Antique Condensed No. 46 . . . . .	129	Brass Dash Rules	12
Antique Extended . . . . .	135	Brass Head Rules	12
Antique Extended No. 40 . . . . .	134	Brass Leaders . . . . .	23
Antique Extended No. 45 . . . . .	135	Brass Leads and Slugs	12
Antique Extra Condensed No. 42 . . . . .	131	Brass Ovals . . . . .	21
Apollo . . . . .	294	Brass Rules, Strips . . . . .	13-17
Apple Blossom Ornaments	373	Brass Scoring Rules . . . . .	23
Armenian	37	Brass Space Rule	23
Arrows . . . . .	367	Brass Type . . . . .	24
Art Borders	386-390	Broadgauge . . . . .	171
Art Gothic . . . . .	248	Broadgauge Ornate	327
Art Initials	362	Broadgauge Shaded . . . . .	327
Atlanta . . . . .	230	Burritt Text	282
Augustan Text . . . . .	335		
BALLET DANCERS . . . . .	408	CALEDONIAN No. 30 . . . . .	126
Barta Borders . . . . .	382	Campaigners . . . . .	408
Barth Geometrical Borders	399	Cancelled Figures	41
Baseball, Series No. 1	411	Card Indicators	367
Baskerville . . . . .	176	Card Pips . . . . .	367
Bill of Fare . . . . .	458	Caslon Old Style Italic No. 71	63
Billhead Logotypes	422	Caslon Old Style No. 71	60-62
Black Fists . . . . .	369	Caxton Black	328
Boldface German . . . . .	357	Caxton Borders	374
Boldface Italic No. 40 . . . . .	116	Caxtonian . . . . .	326
Boldface Roman No. 40 . . . . .	116	Celtic No. 42 . . . . .	182
<b>Borders:</b> —		Central Ornaments	371, 372
—Art . . . . .	386-390	Century Roman . . . . .	98, 99
—Barta . . . . .	382	Chamfer Condensed . . . . .	141
—Barth Geometrical . . . . .	399	Chaucer . . . . .	300
—Caxton . . . . .	374	Check Blanks	423
—Collins . . . . .	379, 380	Checkers . . . . .	366
—Combination, Series 97 . . . . .	402	Chessmen . . . . .	366
—Combination, Series 98, 1st Sect. . . . .	400	Childs . . . . .	239
—Combination, Series 98, 3d Sect. . . . .	401	Christmas Ornaments . . . . .	405
—Contour . . . . .	384, 385	Circular Black . . . . .	300
—Eighteen Point	395	Circular Quads . . . . .	10
—Elzevir . . . . .	381	Circular Script . . . . .	293
—Empire . . . . .	375	Clarendon . . . . .	132
—Flame . . . . .	397	Coats of Arms	441-445
—Florentine . . . . .	383	Collins Bands	380
—Half Nonpareil . . . . .	398	Collins Borders . . . . .	379
—Laurel . . . . .	376	Collins Florets . . . . .	378, 379
—Newspaper . . . . .	391-395	Columbian . . . . .	244
—Rococo . . . . .	374	Columbus No. 2 . . . . .	200, 201
—Twelve Point . . . . .	396	Columbus Initials . . . . .	201
—Twenty-four Point . . . . .	396	Columbus Outline . . . . .	202, 203
Boston Black . . . . .	333	Columbus Outline Initials . . . . .	203
Boston Script . . . . .	306, 307	Combination Borders . . . . .	400-402
Bowlers . . . . .	407	Combination Condensed Gothic . . . . .	138
		Combination Gothic . . . . .	137, 138

# Index to Type Specimens

	PAGE		PAGE
Combination Italic Gothic . . . . .	165	Elzevir Borders	351
Combination Ornaments, Series K	403	Elzevir Florets . . . . .	381
Commercial Logotypes	422	Elzevir Gothic	254, 255
Condensed Clarendon . . . . .	133	Empire Borders . . . . .	375
Condensed German Title	354	Engraving Blanks . . . . .	407
Condensed Title No. 43 . . . . .	121	Epitaph . . . . .	207
Contour Bands and Borders . . . . .	384, 385	Epitaph Open	207
Contour No. 1	216	Erratick . . . . .	212
Contour No. 2	220	Erratick Outline . . . . .	213
Contour No. 3	220	Extra Condensed No. 40 . . . . .	119
Contour No. 4	217	Extra Condensed No. 43 . . . . .	118
Contour No. 5	221	Extra Condensed No. 45 . . . . .	120
Contour No. 6	218	Extra Condensed No. 46 . . . . .	119
Contour No. 7 . . . . .	219		
Contour Palmetto Ornaments . . . . .	371	FACADE . . . . .	241
Contour Pointers . . . . .	370	Facade Condensed . . . . .	242
Copper Alloy Fine-Dot Leaders	23	Facade Condensed No. 2	243
Copper Alloy Imprints . . . . .	370	Fillet . . . . .	324
Copper Alloy Take Slugs	10	Fine Dot Leaders	23
Copperplate Roman . . . . .	317	Fists . . . . .	369
Coppers	410	Five-Pointed Stars . . . . .	368
Corner Quads	10	Flame Borders . . . . .	397
Crayon . . . . .	321	Florentine Borders . . . . .	383
Cushing . . . . .	70	Florentine Heavyface . . . . .	274
Cushing Italic . . . . .	71	Florentine Old Style No. 2 . . . . .	252, 253
Cushing Monotone	72	Footprints . . . . .	407
Cushing Old Style . . . . .	96	Fractions . . . . .	40, 41
Cuts	424-462	Franklin Old Style No. 79 . . . . .	56-59, 86, 87
		French Clarendon No. 40 . . . . .	169
DELMONICO'S Chefs and Waiters . . . . .	411	French Clarendon Extended No. 40 . . . . .	170
De Vinne . . . . .	188, 189	French Clarendon Extra Cond. No. 40	168
De Vinne Condensed	190, 191	French Elzevir No. 1 . . . . .	69
De Vinne Extended . . . . .	194, 195	French Old Style Extended . . . . .	181
De Vinne Extra Condensed . . . . .	192, 193	French Old Style No. 2 . . . . .	64-68
De Vinne Fractions	40	French Script . . . . .	288-290
De Vinne Italic . . . . .	196, 197	Furniture, Metal	11
De Vinne Italic Outline . . . . .	198, 199		
De Vinne Shaded . . . . .	206	GERMAN, No. 42 . . . . .	353
Domestics	411	German Faces . . . . .	348-361
Doric No. 40 . . . . .	127	German Poster Series . . . . .	349, 352
Doric Fractions	41	German Title	355, 357
Doric Italic	167	Gothic No. 16 . . . . .	157
Druggists	410	Gothic No. 47 . . . . .	142
Duerer . . . . .	225	Gothic No. 48 . . . . .	156
Dynamo	249	Gothic No. 49 . . . . .	156
		Gothic Condensed . . . . .	139, 140, 158-161
EAGLES . . . . .	442, 443	Gothic Condensed No. 36 . . . . .	159
Ecclesiastical Cuts . . . . .	426, 427	Gothic Condensed No. 37 . . . . .	158
Egyptian No. 25 . . . . .	177	Gothic Condensed No. 44 . . . . .	161
Eighteen Point Borders	395	Gothic Condensed No. 45 . . . . .	160
Elandkay . . . . .	251	Gothic Condensed No. 46 . . . . .	139
Electric Ornaments . . . . .	373	Gothic Condensed No. 112 . . . . .	139
Electrotyped Initials . . . . .	364, 365	Gothic Condensed No. 127 . . . . .	140
Electrotyped Take Slugs	10	Gothic Extra Condensed No. 42 . . . . .	162
<b>Electrotyped Cuts:—</b>		Gothic Fractions . . . . .	41
—Bill of Fare . . . . .	458	Gothic Italic . . . . .	166
—Coats of Arms . . . . .	440-445	Gothic Italic Extra Condensed . . . . .	163
—Eagles . . . . .	442, 443	Graphic . . . . .	221
—Ecclesiastical . . . . .	426, 427	Greek . . . . .	29-33
—Flags . . . . .	440-443	Grolier . . . . .	208
—Menu . . . . .	458		
—Miscellaneous . . . . .	448-462	HALF-TITLE . . . . .	115, 116
—National Emblems . . . . .	442, 443	Half Nonpareil Borders	308
—Portraits . . . . .	447	Half-tone . . . . .	321
—Society Emblems . . . . .	424-440, 446	Hamburg . . . . .	334
—State Seals . . . . .	444, 445	Happy Thoughts . . . . .	404
—Wine List . . . . .	458	Hardware . . . . .	171
Elzevir Bands	381	Harvard Italic . . . . .	284, 285

# Index to Type Specimens

	PAGE		PAGE
Heavyface Greek	31	Lining Gothic Extended No. 40 . . .	155
Hebrew . . . . .	34-36	Lippincott . . . . .	184
Heintzemann . . . . .	358	Listeners . . . . .	408
Howland . . . . .	204, 205	Litho . . . . .	295
Howland Open . . . . .	204, 205	Livermore . . . . .	214
<b>IHLNBURG . . . . . 356</b>		Livermore Outline . . . . .	215
Imprints . . . . .	370	Locus Sigilli . . . . .	367
Inclined Gothic . . . . .	164	Longfellow . . . . .	237
Index Corners . . . . .	451	Luray . . . . .	322
Index Cuts . . . . .	369	<b>MAIL LIST LOGOTYPES . . . . . 45</b>	
Index Initials . . . . .	364	Mail List Type . . . . .	45
Inferior Letters and Figures . . . . .	38	Maltese Crosses . . . . .	368
Initial Letters . . . . .	276-279, 362-365	Manuscript . . . . .	301
Ink Spots . . . . .	407	Margin Ornaments . . . . .	405
Insects . . . . .	407	Master Script . . . . .	292
Inscription Greek . . . . .	31	McCullagh . . . . .	228, 229
Interesting Data for Printers . . . . .	6-9	Medallic . . . . .	325
Iroquois . . . . .	232	Medical Signs . . . . .	42
Iroquois Condensed . . . . .	233	Metal Braces and Dashes . . . . .	22
<b>JEFFERSON . . . . . 223</b>		Metal Corner Quads . . . . .	10
Jenson Initials . . . . .	265	Metal Furniture . . . . .	11
Jenson Italic . . . . .	266-269	Miscellaneous Cuts . . . . .	448-462
Jenson Old Style . . . . .	256-264	Miscellaneous Signs . . . . .	42
Jenson Ornaments . . . . .	256-259, 265	Modern Antique . . . . .	174, 175
Johnson . . . . .	238	Modern Antique Wide No. 110 . . . . .	173
Johnson Gothic . . . . .	142	Modern Fraktur . . . . .	359
<b>KATE Greenaways Mignonettes . 412, 413</b>		Modern Text No. 40 . . . . .	335
Keystone . . . . .	173	Morris Initials . . . . .	265, 365
Koster . . . . .	236	Mortised No. 2 . . . . .	363
<b>LABOR-SAVING BRASS LEADERS . . . 23</b>		Mural . . . . .	240
Labor-Saving Brass Rule . . . . .	18, 19	Mural Ornaments . . . . .	405
Labor-Saving Leads and Slugs . . . . .	10	Music . . . . .	25-28
Labor-Saving Quotation Furniture . . . . .	11	<b>NATIONAL EMBLEMS . . . . . 442, 443</b>	
Labor-Saving Reversible Metal Furniture . . . . .	11	Newspaper Borders . . . . .	391-395
Lacleda . . . . .	283	Newspaper Cuts . . . . .	462
Lady Speakers . . . . .	413	Newspaper Headings . . . . .	417-421
Lafayette . . . . .	222	Norman Condensed . . . . .	182
Latin Antique No. 40 . . . . .	179	Novelty Script . . . . .	302
Latin Compressed No. 30 . . . . .	177	<b>OLD STYLE No. 43 . . . . . 88</b>	
Latin Extended . . . . .	172	Old Style No. 44 . . . . .	88
Laurel Borders . . . . .	376	Old Style Antique No. 40 . . . . .	94, 95
Laurel Ornaments . . . . .	377	Old Style Antique No. 42 . . . . .	178
Laurel Wreaths . . . . .	406	Old Style Bold . . . . .	93
Law Italic . . . . .	320	Old Style Condensed No. 4 . . . . .	91
Leads and Slugs . . . . .	10	Old Style Condensed No. 40 . . . . .	89
Lightface . . . . .	114, 115, 122	Old Style Condensed No. 42 . . . . .	89
Lightface Celtic . . . . .	180	Old Style Condensed No. 43 . . . . .	90
Lightface No. 43 . . . . .	114	Old Style Extended . . . . .	92
Lightface No. 44 . . . . .	115	Old Style Fractions . . . . .	40
Lightface No. 45 . . . . .	122	Old Style Italic Job Fonts . . . . .	86
Lightface No. 46 . . . . .	114	Old Style Latin Condensed No. 30 . . . . .	97
Lightface Condensed . . . . .	111-113, 122	Old Style Roman Job Fonts . . . . .	87
Lightface Condensed No. 44 . . . . .	112	Old Style Script . . . . .	303
Lightface Condensed No. 45 . . . . .	113	Old Style Title . . . . .	84, 85
Lightface Condensed No. 46 . . . . .	111	Ornamental Cast Initials . . . . .	362, 363
Lightface Condensed No. 47 . . . . .	112	Outline Figures . . . . .	450
Lightface Extended No. 40 . . . . .	123	<b>Ornaments:—</b>	
Lightface Figures . . . . .	44	—Apple Blossom . . . . .	373
Lightface Runic No. 30 . . . . .	183	—Central . . . . .	371, 372
Lining Antique . . . . .	136	—Christmas . . . . .	405
Lining Gothic . . . . .	137, 143-154	—Collins Florets . . . . .	378, 379
Lining Gothic No. 43 . . . . .	143	—Combination, Series K . . . . .	403
Lining Gothic No. 44 . . . . .	144	—Electric . . . . .	373
Lining Gothic No. 45 . . . . .	145	—Elzevir Florets . . . . .	381
		—Happy Thoughts . . . . .	404

# Index to Type Specimens

	PAGE	
<b>Ornaments:—Continued.</b>		
—Laurel . . . . .	377	
—Margin . . . . .	495	
—Mural . . . . .	405	
—Palmetto . . . . .	371	
—Pointers . . . . .	370	
—Scroll Corner . . . . .	373	
<b>Outline Type:—</b>		
—Bradley Outline . . . . .	280	
—Central Ornaments No. 2 . . . . .	371	
—Columbus Outline . . . . .	202, 203	
—Contour Bands and Borders . . . . .	384, 385	
—Contour Palmetto Ornaments . . . . .	371	
—Contour Pointers . . . . .	370	
—De Vinne Italic Outline . . . . .	198, 199	
—De Vinne Shaded . . . . .	206	
—Figures . . . . .	450	
—Howland Open . . . . .	204, 205	
—Livermore Outline . . . . .	215	
—Quaint Open . . . . .	209	
—Satanick Open . . . . .	273	
—Virile Open . . . . .	211	
<b>PALMETTO ORNAMENTS . . . . .</b>	<b>371</b>	
Pencraft . . . . .	299	
Perforating Rules . . . . .	23	
Perpetual Calendar Logotypes . . . . .	414, 415	
Philadelphia Liniug Gothic . . . . .	146-154	
Pickups . . . . .	410	
Piece Accents . . . . .	43	
Piece Fractions . . . . .	38, 39	
Pointers . . . . .	370	
Plain Faces . . . . .	100-110	
Porson Greek . . . . .	30	
Portraits . . . . .	447	
Poster Antique . . . . .	336, 337	
Poster Caledonian No. 30 . . . . .	342, 343	
Poster DeVinne . . . . .	338, 339	
Poster DeVinne Condensed . . . . .	340, 341	
Poster Doric No. 40 . . . . .	344, 345	
Poster Lightface No. 45 . . . . .	346, 347	
Priony Text . . . . .	329	
<b>QUAINT . . . . .</b>	<b>208</b>	
Quaint Open . . . . .	209	
Quaint Roman No. 2 . . . . .	234	
Quentell . . . . .	186, 187	
Quotation Furniture . . . . .	11	
<b>RABBINIC . . . . .</b>	<b>37</b>	
Recipe Marks . . . . .	367	
Reversible Metal Furniture . . . . .	11	
Rigs and Traps . . . . .	409	
Rococo Border . . . . .	374	
<b>Roman and Italic, Modern:—</b>		
—Century Roman . . . . .	98, 99	
—Plain Faces . . . . .	100-110	
—Roman No. 44 . . . . .	110	
—Self-Spacing . . . . .	48-51	
<b>Roman and Italic, Old Style:—</b>		
—Caslon No. 71 . . . . .	60-62	
—Caslon Italic No. 71 . . . . .	63	
—Cushing . . . . .	70	
—Cushing Italic . . . . .	71	
—Cushing Monotone . . . . .	72	
—Franklin No. 79 . . . . .	56-59, 86, 87	
—French Elzevir No. 1 . . . . .	69	
<b>Roman and Italic, Old Style:—</b>		
—French Old Style No. 2 . . . . .	64-68	
—Ronaldson No. 72 . . . . .	73-78	
—Self-Spacing . . . . .	52-54	
Roman No. 44 . . . . .	110	
Ronaldson Clarendon . . . . .	82	
Ronaldson Condensed . . . . .	79	
Ronaldson Extended . . . . .	80	
Ronaldson Gothic . . . . .	83	
Ronaldson Job Fonts . . . . .	77, 78	
Ronaldson Old Style No. 72 . . . . .	73-78	
Ronaldson Title Slope . . . . .	81	
Royal Script . . . . .	304, 305	
Rubens . . . . .	226, 227	
Russian No. 10 . . . . .	37	
<b>SAMOA . . . . .</b>	<b>235</b>	
Sansom Script . . . . .	291	
Satanick . . . . .	270-272	
Satanick Open . . . . .	273	
Schœffer Old Style . . . . .	275-277	
Schœffer Old Style Initials . . . . .	276, 277	
Schwabacher . . . . .	361	
Schwabacher No. 2 . . . . .	360	
Scorchers . . . . .	409	
Script No. 9 . . . . .	297	
<b>Scripts:—</b>		
—Boston . . . . .	306, 307	
—Circular . . . . .	293	
—French . . . . .	288-290	
—Manuscript . . . . .	301	
—Master . . . . .	292	
—Novelty . . . . .	302	
—No. 9 . . . . .	297	
—Old Style . . . . .	303	
—Royal . . . . .	304, 305	
—Sansom . . . . .	291	
—Spencerian . . . . .	310-315	
—Steelplate . . . . .	308, 309	
Scroll Corner Ornaments . . . . .	373	
Sectional Calendars . . . . .	416	
Self-Spacing German . . . . .	350, 351	
Self-Spacing Old Style Bold . . . . .	55	
Self-Spacing Piece Fractions . . . . .	39	
Self-Spacing Signs . . . . .	47	
Self-Spacing Type . . . . .	46-55	
Shaded Palmetto Ornaments . . . . .	371	
Shaded Pointers . . . . .	370	
Shadow . . . . .	322	
Shaved Leads and Slugs . . . . .	10	
Silhouettes . . . . .	410	
Slocum Seals . . . . .	407	
Smith-Premier Type-Writer . . . . .	318	
Society Emblems . . . . .	424-440, 446	
Speakers . . . . .	408	
Special Figures . . . . .	41	
Special Fractions . . . . .	38	
Spencerian Script . . . . .	310-315	
Staudard Type-Writer . . . . .	318	
Stars . . . . .	368	
Star Rule (wood) . . . . .	496	
State Seals . . . . .	444, 445	
Steel Cutting Rules . . . . .	23	
Steelplate Gothic . . . . .	323	
Steelplate Script . . . . .	308, 309	
Stencil . . . . .	325	
Stenograf . . . . .	319	



# Index to Type Specimens

	PAGE		PAGE
Stipple . . . . .	324	United States Seals and Emblems, 442, 443	368
Stylus . . . . .	286	United States Signal Flags . . . . .	368
Stylus No. 2 . . . . .	287		
Superior Letters and Figures . . . . .	38	VERTICAL WRITING . . . . .	316
TAKE SLUGS . . . . .	10	Victoria . . . . .	231
Taylor Gothic . . . . .	185	Victoria Italic . . . . .	250
Time-Saving Mail List Type . . . . .	45	Virile . . . . .	210
Time-Table Figures . . . . .	44	Virile Open . . . . .	211
Tinted . . . . .	323	WASHINGTON . . . . .	224
Title No. 43 . . . . .	117	Waverly Circular . . . . .	295
Title Italic No. 42 . . . . .	117	Webster . . . . .	245
Title Black . . . . .	332	Whist Markers . . . . .	367
Title Extended No. 42 . . . . .	123	White-Face Figures . . . . .	44
Tristan Italic . . . . .	296	Wine List . . . . .	458
Tudor Black . . . . .	330	Wood Borders . . . . .	497
Twelve Point Borders . . . . .	396	Wood Pointers . . . . .	496
Twenty-four Point Borders . . . . .	396	Wood Rule . . . . .	496
Type-Writer . . . . .	318, 319	Wood Type . . . . .	495-512
UNIQUE CELTIC . . . . .	246	YONKERS . . . . .	331
Unique Celtic Condensed . . . . .	247	Yost Typewriter . . . . .	319

# Index and Price List of Cuts

	PAGE		PAGE
Agricultural . . . . .	455	Horses . . . . .	453, 454
Anchor . . . . .	448	Horseshoe Emblems . . . . .	461
Animals . . . . .	452, 459	Ice Wagon . . . . .	456
Anvil . . . . .	460	Keystones . . . . .	461
Balloon . . . . .	459	Labor Emblem . . . . .	448
Baseball . . . . .	411	Lawn Tennis . . . . .	453
Bees and Hives . . . . .	448	Liberty . . . . .	449
Bells . . . . .	449	Masquerade . . . . .	453
Billhead Logotypes . . . . .	422	Medical . . . . .	411, 460
Bill of Fare . . . . .	458	Menu . . . . .	458
Blacksmith . . . . .	454	Newspaper . . . . .	462
Blank Books . . . . .	460	Optician . . . . .	460
Boots and Shoes . . . . .	450	Owls . . . . .	456
Bowling . . . . .	453	Patriotic . . . . .	442, 443, 446
Buffalo . . . . .	452	Political . . . . .	452, 460
Business Cuts . . . . .	450	Portraits . . . . .	447
Café . . . . .	458	Poultry . . . . .	448, 456
Carriages . . . . .	455	Racing . . . . .	453
Cattle . . . . .	452, 455	Railroads . . . . .	457
Check Blanks . . . . .	423	Religious . . . . .	426, 427
Coal Carts . . . . .	455	Restaurant . . . . .	411, 458
Coats of Arms . . . . .	441, 444, 445	Santa Claus . . . . .	449
Commercial Logotypes . . . . .	422	Sleigh . . . . .	455
Cross and Crown . . . . .	426, 428, 429	Society Emblems . . . . .	424-440, 446
Deer . . . . .	452	Spectacles . . . . .	460
Dentist . . . . .	460	Stars . . . . .	368, 461
Dogs . . . . .	448, 452	State Seals . . . . .	444, 445
Druggist . . . . .	411, 460	Steamships . . . . .	457
Eagles . . . . .	442, 443, 456	Tailor . . . . .	450
Electrical . . . . .	459	Tea . . . . .	459
Elephants . . . . .	452	Teapins . . . . .	453
Eye . . . . .	460	Telephone . . . . .	459
Eye Glasses . . . . .	460	Thistle . . . . .	438
Express Wagons . . . . .	455	Tobacco . . . . .	459
Fire Engines . . . . .	437	Typographical . . . . .	437
Flags . . . . .	440, 442, 443	Undertaker . . . . .	455
Flowers and Fruit . . . . .	459	Wine List . . . . .	458, 459

# Index and Price List of Cuts

NO.	PAGE	PRICE	NO.	PAGE	PRICE	NO.	PAGE	PRICE	NO.	PAGE	PRICE
234A	438	\$.40	3170A	436	\$.60	62B	462	\$.12	192B	434	\$.75
828A	437	1.00	3171A	433	1.00	63B	462	.08	193B	446	.45
987A	438	.60	3172A	438	.50	65B	462	.12	196B	446	.60
1750A	456	.50	3174A	439	.60	67B	462	.25	197B	446	.60
1850A	428	.40	3176A	436	.50	69B	462	.25	198B	446	.60
2014A	436	.40	3178A	438	.75	70B	462	.25	200B	446	.90
2069A	438	.30	3185A	431	1.00	71B	462	.12	201B	446	.75
2079A	428	.50	3186A	432	1.00	72B	462	.25	202B	446	.75
2105A	459	.50	3189A	436	.50	73B	462	.12	203B	438	1.00
2241A	429	.75	3190A	431	1.25	74B	462	.15	204B	438	.90
2319½A	435	.75	3191A	432	.75	75B	462	.12	205B	438	.75
2434A	429	1.00	3194A	439	1.25	76B	462	.25	206B	439	.60
2438A	429	1.00	3196A	439	1.25	77B	429	.15	207B	439	.90
2601A	432	.65	3198A	437	1.00	78B	462	.15	208B	439	.40
2766A	430	.90	3200A	437	1.00	79B	429	.15	209B	438	.50
2820A	431	.50	3201A	437	.75	80B	429	.15	211B	439	.75
2857A	436	1.00	3321A	429	1.00	81B	429	.15	212B	439	.90
2882A	440	.30	3323A	428	.60	82B	429	.15	213B	425	.75
3024A	429	.30	3327A	428	.75	83B	429	.15	214B	425	.60
3027A	428	.30	3356A	431	.50	84B	462	.15	215B	424	.75
3044A	428	.75				85B	462	.15	216B	424	.90
3059A	428	.75	1B	462	.08	86B	462	.15	217B	425	.35
3060A	429	1.00	8B	462	.12	87B	462	.15	220B	425	.35
3066A	428	.75	9B	462	.12	90B	462	.15	221B	425	.40
3072A	429	1.00	11B	462	.08	91B	462	.15	222B	425	.40
3076A	435	.60	12B	462	.12	92B	462	.15	223B	424	.50
3077A	428	.40	13B	462	.08	93B	462	.25	224B	425	.60
3078A	428	.75	14B	462	.12	94B	462	.25	225B	425	.60
3079A	428	1.00	15B	462	.12	95B	462	.15	226B	424	.75
3083A	428	1.00	19B	462	.12	96B	462	.25	227B	425	.50
3089A	431	.75	20B	462	.12	98B	462	.15	228B	425	.75
3092A	431	.50	21B	462	.12	99B	462	.25	229B	424	.50
3093A	431	.60	22B	462	.12	101B	462	.25	230B	425	.60
3099A	430	.30	23B	462	.12	102B	462	.15	231B	425	1.00
3104A	430	.40	24B	462	.12	103B	462	.15	232B	424	.60
3109A	428	.35	25B	462	.25	104B	462	.15	233B	425	.50
3110A	430	.40	26B	462	.12	105B	462	.25	234B	425	.75
3118A	430	.75	27B	462	.12	106B	462	.25	235B	424	.40
3119A	430	.75	28B	462	.08	107B	462	.25	236B	424	.40
3121A	430	1.00	29B	462	.12	111B	462	.25	237B	424	.70
3122A	430	1.00	30B	462	.08	112B	462	.25	238B	425	.75
3123A	430	1.00	31B	462	.08	113B	462	.25	239B	425	.90
3126A	432	.60	32B	462	.08	114B	462	.25	240B	424	.40
3129A	431	.60	34B	462	.12	115B	454	.25	241B	424	.40
3131A	436	.60	35B	462	.12	118B	462	.25	242B	424	.40
3132A	434	.50	36B	462	.12	119B	462	.25	243B	424	.40
3133A	434	.60	37B	462	.12	123B	453	.25	244B	425	.75
3135A	431	.40	38B	428	.12	125B	437	.35	245B	424	.35
3136A	431	.60	39B	462	.25	127B	437	.35	246B	436	.40
3139A	434	.60	40B	462	.12	132B	448	.30	247B	436	.50
3141A	436	.50	41B	462	.08	162B	447	1.25	248B	436	.75
3142A	435	.50	42B	462	.12	163B	429	.75	249B	436	.90
3143A	439	.60	43B	462	.12	164B	429	.50	250B	436	.50
3144A	439	.60	44B	462	.12	166B	428	.30	251B	436	.50
3145A	439	.30	45B	462	.08	168B	428	.75	252B	436	.50
3146A	434	.60	46B	430	.25	170B	428	.40	254B	433	1.00
3147A	435	.50	47B	462	.12	172B	428	.25	255B	434	1.50
3148A	435	.50	48B	462	.12	173B	430	.25	256B	435	.75
3149A	435	.75	49B	462	.12	174B	430	1.00	259B	439	1.00
3150A	435	.60	50B	462	.25	175B	430	1.00	260B	434	.75
3152A	434	1.00	51B	462	.12	176B	430	1.00	261B	434	.40
3153A	434	1.00	52B	462	.12	177B	430	.35	262B	436	.75
3154A	435	1.00	53B	462	.12	181B	430	.60	263B	436	.75
3157A	431	.60	54B	462	.15	183B	431	.40	266B	436	.50
3159A	434	.50	56B	462	.08	184B	431	.90	267B	431	.75
3161A	434	.75	58B	462	.12	185B	432	1.00	268B	436	1.15
3162A	434	.60	59B	462	.12	187B	432	1.00	269B	459	1.00
3167A	434	1.00	60B	462	.12	190B	432	1.25	270B	459	1.00
3168A	433	.60	61B	462	.12	191B	432	.50	272B	459	.35

# Index and Price List of Cuts

NO.	PAGE	PRICE	NO.	PAGE	PRICE	NO.	PAGE	PRICE	NO.	PAGE	PRICE
273B	.459	\$.45	2396C	.452	\$.25	3073C	.443	\$.75	3445C	.448	\$.50
275B	.459	.50	2418C	.457	.50	3084C	.449	.75	3452C	.452	.30
276B	.460	.50	2419C	.448	.40	3085C	.449	1.00	3454C	.429	1.00
277B	.460	.35	2421C	.445	.50	3107C	.445	1.00	3455C	.426	.50
278B	.424	.40	2425C	.460	.40	3109C	.445	1.00	3456C	.455	1.00
279B	.444	.75	2431C	.429	1.00	3124C	.445	1.00	3460C	.443	.25
280B	.444	.75	2432C	.428	.50	3142C	.449	1.00	3466C	.457	.50
3559B	.456	.50	2435C	.447	1.50	3143C	.449	1.00	3467C	.448	.75
			2436C	.442	1.25	3146C	.459	.75	3471C	.455	.75
92C	.422	.30	2439C	.448	1.00	3156C	.456	1.00	3487C	.444	1.00
93C	.422	.35	2441C	.448	1.00	3165C	.427	.40	3653C	.426	.35
94C	.422	.40	2442C	.442	.30	3166C	.426	.40	3654C	.429	.40
95C	.422	.40	2443C	.443	.30	3167C	.427	.40	3655C	.426	.30
97C	.422	.40	2453C	.460	.40	3168C	.426	.40	3656C	.430	.40
99C	.422	.35	2459C	.447	.37	3169C	.426	.80	3657C	.431	.40
103C	.422	.40	2466C	.460	.50	3170C	.426	.40	3658C	.431	.35
104C	.422	.40	2467C	.461	.50	3171C	.426	.30	3659C	.435	.40
105C	.422	.40	2470C	.455	.75	3172C	.426	.30	3661C	.430	.30
106C	.422	.40	2471C	.442	.50	3175C	.448	.80	3662C	.432	.40
107C	.422	.40	2503½C	.445	.50	3181C	.443	.60	3677C	.452	1.25
108C	.422	.40	2537C	.442	.50	3182C	.443	.75	3682C	.429	.50
236C	.426	.08	2678C	.460	.75	3198C	.461	.40	3685C	.435	.50
319C	.423	.50	2681C	.460	1.25	3204C	.453	.60	3711C	.438	.35
320C	.423	.50	2695C	.454	.75	3212C	.452	.75	3716C	.445	.50
321C	.423	.40	2708C	.447	1.50	3215C	.452	.75	3717C	.445	.75
322C	.423	.40	2709C	.442	.50	3271C	.449	.60	3718C	.445	1.00
323C	.423	.75	2711C	.442	.50	3272C	.437	.75	3719C	.445	1.50
323½C	.423	.75	2726C	.456	.25	3273C	.437	1.00	3756C	.452	1.25
326C	.423	.75	2727C	.456	.25	3279C	.426	.50	3778C	.447	1.50
326½C	.423	.75	2728C	.456	.30	3280C	.448	.40	3779C	.447	1.00
327C	.423	.75	2746C	.459	.50	3281C	.448	.60	3788C	.461	1.00
327½C	.423	.75	2749C	.459	.45	3288C	.454	.75	3784C	.437	.50
328C	.423	.75	2751C	.444	1.75	3290C	.437	.50	3785C	.453	.75
328½C	.423	.75	With Seal 2.50			3292C	.460	.30	3787C	.452	1.25
329C	.423	.40	2759C	.444	.75	3293C	.448	.30	3790C	.432	1.00
330C	.423	.30	2761C	.444	.75	3354C	.427	.35	3794C	.449	.50
420C	.426	.30	2776C	.444	.75	3355C	.427	.35	3795C	.449	.75
448C	.437	.30	2817C	.455	.40	3356C	.427	.40	3796C	.449	1.25
1225C	.426	.25	2891C	.459	.75	3357C	.427	.35	3800C	.456	.30
1608C	.448	.30	2904C	.447	.50	3358C	.427	.25	3813C	.445	.50
1608½C	.448	.30	2906C	.453	.75	3359C	.426	.25	3815C	.445	1.25
1609C	.448	.30	2920C	.443	1.00	3360C	.427	2.00	3816C	.456	1.50
1733C	.453	.50	2922C	.442	1.25	3361C	.426	.50	3818C	.447	1.50
1856C	.453	.30	2929C	.456	1.00	3362C	.426	.30	3929C	.443	1.85
1865C	.439	.30	2941C	.449	.25	3363C	.427	.30	3941C	.457	1.00
1906C	.443	.30	2942C	.448	.15	3364C	.427	.30	3944C	.456	.25
2015C	.456	.50	2943C	.448	.15	3365C	.427	.35	3948C	.461	.75
2016C	.449	.25	2945C	.452	.25	3370C	.454	.50	3949C	.461	.50
2035C	.456	.50	2946C	.456	.25	3372C	.426	.35	3952C	.446	1.00
2048C	.435	.75	2948C	.449	.25	3378C	.454	.50	3953C	.446	.75
2092C	.454	.50	2950C	.448	.15	3380C	.455	1.00	3955C	.446	.60
2135C	.426	.25	2952C	.452	.25	3383C	.427	.35	3957C	.453	.60
2213½C	.442	1.50	2954C	.452	.25	3384C	.427	2.00	3958C	.450	.90
2220C	.444	1.50	2970C	.429	.50	3399C	.428	.50	3969C	.450	.90
2222C	.444	1.50	2971C	.426	.25	3400C	.428	.50	3970C	.429	.60
2266C	.443	1.00	2984C	.461	.75	3401C	.428	.50	3972C	.434	.60
2285C	.459	.37	2985C	.461	.75	3402C	.428	.50	3982C	.440	.30
2290½C	.443	.75	2997C	.459	1.00	3403C	.428	.50	3995C	.452	.60
2302C	.449	.50	2998C	.426	.25	3404C	.428	.50	3996C	.432	.75
2309½C	.426	.38	3002½C	.426	.15	3407C	.426	.60	3997C	.457	.75
2312½C	.453	.38	3023C	.442	.25	3409C	.448	1.00	4054C	.458	.75
2317C	.448	.40	3030C	.426	.30	3410C	.460	1.00	4056C	.458	.75
2332C	.455	1.00	3031C	.426	.30	3417C	.432	.30	4058C	.458	.75
2356C	.455	.50	3034C	.437	1.00	3418C	.432	.60	4059C	.458	.75
2364C	.461	.50	3037C	.454	.60	3419C	.432	.75	4060C	.458	.60
2385C	.442	.75	3038C	.454	.60	3436C	.453	.60	4065C	.458	.75
2386C	.442	1.25	3051C	.448	.75	3438C	.448	.40	4066C	.458	.75
2389C	.443	1.00	3055C	.456	.40	3439C	.461	.50	4069C	.458	.75
2395C	.448	.25	3062C	.455	.30	3440C	.461	.75	4070C	.458	.60

# Index and Price List of Cuts

NO.	PAGE	PRICE	NO.	PAGE	PRICE	NO.	PAGE	PRICE	NO.	PAGE	PRICE
4071C	.458	\$.075	12,120C	.435	\$1.00	12,167C	.438	\$.30	2044E	.461	\$.075
4092C	.455	.75	12,121C	.435	.35	12,168C	.438	.50	2045E	.460	.50
4095C	.447	.40	12,122C	.435	.50	12,169C	.438	.65	2049E	.455	1.00
4096C	.449	1.25	12,123C	.435	.50	12,170C	.453	.40	2050E	.455	1.00
4099C	.456	1.00	12,124C	.435	.60	12,171C	.453	1.00	2052E	.454	1.00
4120C	.457	.75	12,125C	.441	1.25	12,172C	.453	.50	2054E	.454	1.00
4121C	.436	.40	12,126C	.441	.35	12,173C	.453	.40	2055E	.454	1.00
4123C	.431	.75	12,127C	.441	.30	12,174C	.454	1.00	2057E	.453	1.00
4124C	.436	1.00	12,128C	.441	.35	12,175C	.445	.50	2058E	.457	.90
4125C	.446	.40	12,129C	.440	.50	12,176C	.460	.60	2060E	.457	.90
4127C	.452	.75	12,130C	.440	.50	12,177C	.460	.40	2062E	.457	1.00
4129C	.461	.30	12,131C	.441	1.25	12,178C	.460	.50	2066E	.455	1.00
4130C	.461	.35	12,132C	.441	.35	12,179C	.460	.60	2067E	.438	.75
4131C	.461	.40	12,133C	.441	.35	12,180C	.461	.50	2068E	.457	1.00
4132C	.461	.50	12,134C	.441	.35	12,181C	.461	.40	2069E	.457	.75
4140C	.428	1.00	12,135C	.441	.50	12,182C	.461	.50	2072E	.457	1.00
4141C	.447	.75	12,136C	.441	.40	1294D	.460	.80	2074E	.452	.60
4144C	.431	.60	12,137C	.441	.40	1386D	.452	.50	2075E	.452	1.00
4145C	.431	.30	12,138C	.440	.40	1629D	.453	.75	2076E	.452	.50
4148C	.447	.40	12,139C	.441	.50	1744D	.457	.35	2077E	.426	.75
4152C	.425	.40	12,140C	.441	.75	1796D	.453	.35	2078E	.427	1.25
4153C	.425	.30	12,141C	.440	.60	1854D	.460	1.00	2079E	.427	.75
4167C	.457	.40	12,142C	.440	.75	1870D	.437	.25	2080E	.426	.35
4185C	.438	.75	12,143C	.440	.25	1871D	.437	.35	2081E	.427	.70
4201C	.450	.50	12,144C	.440	.30	1872D	.437	.50	2090E	.452	.40
4205C	.450	.50	12,145C	.440	.35	1873D	.437	.60	1109F	.446	1.00
4209C	.450	.50	12,146C	.440	.30	1874D	.437	.75	1207F	.434	.50
4211C	.450	.50	12,147C	.440	.40	2253D	.460	.80	1208F	.434	.60
12,101C	.430	.75	12,148C	.440	.75	3757D	.459	1.50	1230F	.429	.75
12,102C	.430	.60	12,149C	.440	.40	10,332D	.459	.80	1258F	.434	.60
12,103C	.430	.50	12,150C	.440	.30	320E	.457	.12	1262F	.431	.50
12,104C	.432	.75	12,151C	.440	.75	700E	.460	.30	1264F	.431	.75
12,105C	.432	.35	12,152C	.436	.40	865E	.460	.30	1273F	.436	.50
12,106C	.432	.75	12,153C	.437	.60	868E	.460	.35	1277F	.434	.50
12,107C	.433	.75	12,154C	.439	.50	1274E	.435	.40	1280F	.431	.50
12,108C	.433	.30	12,155C	.439	.60	2011E	.435	1.00	1301F	.436	.40
12,109C	.433	.35	12,156C	.439	.35	2022E	.446	1.00	1361F	.431	.50
12,110C	.433	.35	12,157C	.439	.25	2031E	.424	1.25	2068F	.457	1.00
12,111C	.433	.50	12,158C	.439	.90	2034E	.440	.75	2658F	.454	.25
12,112C	.433	.50	12,159C	.439	.30	2036E	.440	.50	4042F	.456	.20
12,113C	.433	1.00	12,160C	.439	.40	2037E	.440	.50	4065F	.455	.20
12,114C	.433	.75	12,161C	.438	.50	2039E	.440	.35	4100F	.443	.25
12,115C	.433	.50	12,162C	.438	.50	2040E	.440	.25	4117F	.454	.25
12,116C	.433	.75	12,163C	.438	.40	2042E	.461	.45	4124F	.453	.30
12,117C	.433	1.00	12,164C	.438	.40	2043E	.453	1.25	4125F	.453	.30
12,118C	.433	1.00	12,165C	.438	1.00						
12,119C	.433	.40	12,166C	.438	.25						

# Index to Price List

Time-Saving Data for Printers . . . . .	6 to 9
Wood Type . . . . .	495 to 512
For the Composing Room . . . . .	517 to 571
For the Press Room . . . . .	572 to 625
For the Stock Room and Bindery . . . . .	626 to 665
For the Mailing Department . . . . .	666 to 668
Miscellaneous . . . . .	669 to 674
Useful Information for Printers . . . . .	693 to 699
Imposition of Forms, with Diagrams . . . . .	700 to 708
Ramaley's Price List of Printing and Binding . . . . .	709 to 736

	PAGE
Acme Staple Binders . . . . .	640-642
Adamson Disc Cover . . . . .	588
Addressing Machines . . . . .	666, 667
Advertising Rules . . . . .	512
Angular Quads . . . . .	510
Backing for Electrotypes . . . . .	672
Beating Tables . . . . .	537
Bellows . . . . .	522
Belting . . . . .	573
Bentrovato . . . . .	589
Benzine Cans . . . . .	576
Blankets, Felt and Rubber . . . . .	572
Bodkins . . . . .	517
Book Sewing Machine, Tennis . . . . .	649
Bookbinders' Case . . . . .	561, 652
Bookbinders' Gold Leaf Stamping Presses . . . . .	656
Bookbinders' Lettering Pallet . . . . .	652
Bookbinders' Metal Type . . . . .	652
Bookbinders' Press Boards . . . . .	665
Bookbinders' Standing Presses . . . . .	664
Bookbinders' Table Shears . . . . .	637
Books for Printers . . . . .	669
Brackets . . . . .	539, 553, 558, 564
—Double Case . . . . .	553
—Tilting Case . . . . .	558
Brass Column Rules . . . . .	512
Brass Dash Rules . . . . .	512
Brass Head Rules . . . . .	512
Brass Leads and Slugs . . . . .	512
Brass Rule Curving Machines . . . . .	525
Brass Type . . . . .	524, 652
Bronze Powders . . . . .	586, 591
Bronze Size . . . . .	586
Bronzing Machines . . . . .	624
Bronzing Mitten . . . . .	591
Bronzing Pad . . . . .	591
Brushes, Benzine . . . . .	573
—Liquid Cement . . . . .	573, 651
—Lye . . . . .	573
—Proof . . . . .	573
—Stereotype Beating . . . . .	573
Cabinets . . . . .	553-563
—American-Polhemus . . . . .	556, 557
—American Steel-Run . . . . .	554

	PAGE
Cabinets— <i>Continued</i>	
—Bookbinders' . . . . .	551, 652
—Combination No. 1 . . . . .	559
—Eagle . . . . .	559
—Electrotype and Cut . . . . .	560
—Ink and Roller . . . . .	563
—Paper and Card Stock . . . . .	588
—Porter's Extension Front . . . . .	563
—Rowen Border and Script . . . . .	555
—Sort . . . . .	562
—Specimen . . . . .	560
—Wisconsin Hard Wood . . . . .	553
—Wisconsin Window . . . . .	558
—Wood Type . . . . .	561
Card Cutters . . . . .	636
Cases . . . . .	544-549
Case Racks . . . . .	551
Case Stands . . . . .	550-552
Case Stands, Wrought Iron . . . . .	552
Chases . . . . .	534-536
Chesapeake Economy Compound . . . . .	587
Circular Quads . . . . .	510
Composing Rules . . . . .	519
Composing Stick Rack . . . . .	520
Composing Sticks . . . . .	518, 519
Copy Holder . . . . .	520
Corner Quads . . . . .	510
Counters . . . . .	583
Crown Engraving Plates . . . . .	671
Curving Machines . . . . .	525
Cutting Boards . . . . .	665
Cutting and Creasing Press, Gally Universal . . . . .	601
Cutting Strips . . . . .	634
Cutting Sticks . . . . .	634
Dillingham Press Punch . . . . .	577
Disc Cover, Adamson . . . . .	588
Dividers . . . . .	522
Dryers . . . . .	586
Drying Racks . . . . .	592, 593
Economy Wrapper Paster . . . . .	668
Electricity Dissipater . . . . .	589
Embossing Composition . . . . .	589
Embossing Made Easy . . . . .	589
Embossing Presses, Hand and Power . . . . .	656, 657

# Index to Price List

	PAGE		PAGE
Embossing Press, Gally Universal	600	Marble Stones	539
Engravers' Tools	669	Matrix Paper	670
Engravers' Wood	669	Metal Furniture	511
Engraving Plates, Hoke Crown	671	Miter Boxes	522
Eyelets	655	Mitering Machines	524
Eyeletting Machines	654, 655	Monitor Wire Stitcher	648
Eyelet Punch and Set	653		
Eye Shade	517	Newspaper File	672
Eureka Type Wash	586	Newspaper Paster	668
		Numbering Frame, Wetter	580
Folders, Bone and Steel	574	Numbering Machines	618
Folding Machines	622, 623	Numbering Machines, Wetter	580-582
—Bennett Country Quarto	623		
—Bennett Economical	623	Overlay Knife	574
—Tribune Newspaper	622		
Foot Sticks, Iron	535	Padding Glue, Elastic	651
Form Truck	536	Padding Glue, Liquid	651
Furniture, Labor-saving	540, 541	Page Cord	517
Furniture and Reglet	540	Paging Machine, Monitor	639
		Pallet, Bookbinders' Lettering	652
Galley Brackets	530	Pallet Ink Knives	574
Galley Cabinets	531	Paper Box Cutting and Creasing Press	601
Galley Lock-up	528	Paper Counter	651
Galley Proof Presses	566, 567	Paper Cutters	626-633
Galley Racks	530	—Advance Power	630
Galleys	526-529	—Chandler & Price	629
Gas and Gasoline Engines	628	—Clipper	628
Gauge Pin Drawer	575	—Dooley Power	631
Gauge Pins and Guides	575	—Feister-Brown Self-Clamping	632, 633
Gloss Varnishes	586	—Peerless Gem	626, 627
Glue Pot	651	—Peerless Power	629
Gold Leaf Lettering Presses	656	—Utility	628
Gripper Perforator, Miller's	594	Paper Jogger	621
Gum Paste	666	Paper Knife	574
		Paste	666
Hack Saws	522	Pasters	668
Hercules Gas Engine	625	Patent Cutting Stick	634
Hercules Liquid Overlay	589	Perfection Wire Stitchers	644-647
Hoke Engraving Plates	671	Perforators	658-661
		Planers	521
Ideal Inking Apparatus	608	Pliers	525
Imposing Surfaces, Iron	539	Power Fixtures	621
Imposing Tables and Stones	538, 539	Press Boards, Bookbinders'	665
Inks	584-586	Press Points	577
Ink Fountains (listed under respective Presses)		Press Punches	577
Ink Knives	574	Printers' Brushes	573
Ink Reducers	587	Printers' Dividers	522
Ink Slabs, Marble	539	Printers' Saw Table	565
Ink Slice	574	Printers' Trucks	594
Inkolenm	587	Printing Inks	584-586
Interlocking Drying Racks, Koerner's	593	Printing Presses	595-620
		—Army	609
Kelsey Copy Holder	520	—Campbell Country	610
Keystone Hack Saw	522	—Chandler & Price Old Style Gordon	595
Knife Grinder	635	—Cottrell Monarch	612
		—Cottrell Paragon	613
Label Holder	520	—Cottrell Triumph	611
Lamp Holder	564	—Cranston Book and News	615
Lead and Rule Cutters	523	—Cranston Newspaper	614, 615
Leader Boxes	522	—Cranston Two-Roller	616
Lead Racks	542	—Cranston-Victor Commercial	618
Leads and Slugs	514	—Cranston-Victor Two-Revolution, Two Rollers	617
Leather Belting	573	—Cranston-Victor Two-Revolution, Four Rollers	619
Letter Board Cabinets	543	—Franklin Gordon, New Style	603
Letter Boards	543	—Gally Universal	596-599
Linotype Galley	528	—Golding Jobber	604
Linotype Planer	521	—Harris' Automatic	602
Liquid Padding Glue	651	—Ideal Hand Cylinder	608
Lock-up Wrenches	537	—Official Hand Lever	606
		—Ostrander-Seymour Pony Web	620
Magnifying Glass	669	—Pearl	605
Mailing Galleys	529	—Peerless	603
Mailing Machines	666	—Pilot Hand Lever	606
—Acme	667	—Prouty, Improved Country	609
—Horton	666, 667	—Washington Hand	607
—Mustang	667	Proof Planers	521
—Ruckenbrod	667	Proof Presses	566, 567
Make-up Rules	519	Punching Machine	653
Make-up Tables	537		
Mallets	521		
Maple Blocks	673		

# Index to Price List

	PAGE		PAGE
Quoin Lock . . . . .	533	Stereotype Chases . . . . .	537
Quoins, Mechanical . . . . .	532, 533	Stereotyping Apparatus . . . . .	670, 671
Quoins, Wooden . . . . .	540	Storage Can . . . . .	576
Quotation Furniture . . . . .	511		
Ratchets for Stereotype Blocks . . . . .	579	Table Shears . . . . .	637
Rawhide Mallets . . . . .	521	Tablet Knife . . . . .	574, 651
Reducing Glass . . . . .	669	Tablet Presses . . . . .	650
Reducing Varnishes . . . . .	586	Take Slugs . . . . .	510
Reglet, Labor-Saving . . . . .	540	Tape . . . . .	572
Roller Cloth . . . . .	572	Tape Couplers . . . . .	573
Roller Supporters . . . . .	590	Tape Fastener . . . . .	572
Rollers . . . . .	590	Tennis Book Sewing Machine . . . . .	649
Rule Bender . . . . .	525	Thorne Type Setting Machine . . . . .	571
Rule Cases . . . . .	545-547	Tint Blocks . . . . .	673
Rule Cutters . . . . .	523	Trucks . . . . .	594
Rule Shaper . . . . .	524	Tweezers . . . . .	517
Ruling Machines . . . . .	662, 663	Tympan Press Boards . . . . .	573
Ruling Pens . . . . .	663	Type-high Gauge . . . . .	564
		Type-high Machine . . . . .	565
Saws . . . . .	522	Type Measures . . . . .	520
Saw Table, Printers' . . . . .	565	Type Wash, Eureka . . . . .	586
Screw Drivers . . . . .	574		
Shooting Sticks . . . . .	522	Varnishes . . . . .	586
Side Sticks . . . . .	540		
Sort Drawers . . . . .	563	Wetter Numbering Machines . . . . .	580, 582
Stabbing Machine, Hand . . . . .	649	Wire, on Spools . . . . .	647
Stamping Presses . . . . .	656, 657	Wire Staples . . . . .	643
Standing Galleys, Wood, etc. . . . .	568, 569	Wire Stitchers . . . . .	644, 648
Standing Galleys, Wrought Iron . . . . .	570	Wrapper Paster, Economy . . . . .	668
Standing Presses . . . . .	664	Wrenches . . . . .	574
Staple Binders . . . . .	640-643	Wood Borders . . . . .	497
Staples, Wire . . . . .	643	Wood Circles . . . . .	673
Star Rule . . . . .	676	Wooden Galleys . . . . .	529
Stereotype Blocks . . . . .	578, 579	Wood Furniture . . . . .	540
—Sectional Metal . . . . .	579	Wood Pointers . . . . .	496
Stereotype Casting Boxes . . . . .	671	Wood Rule . . . . .	496
		Wood Type . . . . .	495-512

## PRICE LIST OF BODY TYPE.

<table style="width: 100%; border-collapse: collapse;"> <tr><td style="width: 10%;">3½ Point</td><td style="width: 10%;">. .</td><td style="width: 10%;">per lb.,</td><td style="width: 10%;">\$5 00</td></tr> <tr><td>3½ Point on 4½ Point,</td><td></td><td>per lb.,</td><td>3 50</td></tr> <tr><td>4½ Point</td><td>. . .</td><td>per lb.,</td><td>1 60</td></tr> <tr><td>5 Point</td><td>. . . .</td><td>per lb.,</td><td>1 20</td></tr> <tr><td>5½ Point</td><td>. . . . .</td><td>per lb.,</td><td>74</td></tr> <tr><td>6 Point</td><td>. . . .</td><td>per lb.,</td><td>64</td></tr> <tr><td>7 Point</td><td></td><td>per lb.,</td><td>56</td></tr> <tr><td>8 Point</td><td></td><td>per lb.,</td><td>52</td></tr> </table>	3½ Point	. .	per lb.,	\$5 00	3½ Point on 4½ Point,		per lb.,	3 50	4½ Point	. . .	per lb.,	1 60	5 Point	. . . .	per lb.,	1 20	5½ Point	. . . . .	per lb.,	74	6 Point	. . . .	per lb.,	64	7 Point		per lb.,	56	8 Point		per lb.,	52	<table style="width: 100%; border-collapse: collapse;"> <tr><td style="width: 10%;">9 Point</td><td style="width: 10%;">. . .</td><td style="width: 10%;">per lb.,</td><td style="width: 10%;">\$0 48</td></tr> <tr><td>10 Point</td><td>. .</td><td>per lb.,</td><td>46</td></tr> <tr><td>11 Point</td><td>. . .</td><td>per lb.,</td><td>44</td></tr> <tr><td>12 Point</td><td>. . .</td><td>per lb.,</td><td>42</td></tr> <tr><td>14 Point</td><td>. . .</td><td>per lb.,</td><td>40</td></tr> <tr><td>15 Point</td><td>. . . .</td><td>per lb.,</td><td>40</td></tr> <tr><td>16 Point</td><td>. . . .</td><td>per lb.,</td><td>40</td></tr> <tr><td>18 Point</td><td>. . . . .</td><td>per lb.,</td><td>40</td></tr> </table>	9 Point	. . .	per lb.,	\$0 48	10 Point	. .	per lb.,	46	11 Point	. . .	per lb.,	44	12 Point	. . .	per lb.,	42	14 Point	. . .	per lb.,	40	15 Point	. . . .	per lb.,	40	16 Point	. . . .	per lb.,	40	18 Point	. . . . .	per lb.,	40
3½ Point	. .	per lb.,	\$5 00																																																														
3½ Point on 4½ Point,		per lb.,	3 50																																																														
4½ Point	. . .	per lb.,	1 60																																																														
5 Point	. . . .	per lb.,	1 20																																																														
5½ Point	. . . . .	per lb.,	74																																																														
6 Point	. . . .	per lb.,	64																																																														
7 Point		per lb.,	56																																																														
8 Point		per lb.,	52																																																														
9 Point	. . .	per lb.,	\$0 48																																																														
10 Point	. .	per lb.,	46																																																														
11 Point	. . .	per lb.,	44																																																														
12 Point	. . .	per lb.,	42																																																														
14 Point	. . .	per lb.,	40																																																														
15 Point	. . . .	per lb.,	40																																																														
16 Point	. . . .	per lb.,	40																																																														
18 Point	. . . . .	per lb.,	40																																																														

Roman and German Body Type is put up in fonts of 25, 50, 100 pounds, or some multiple of these weights. Included in each 25 pounds are 5 pounds of Spaces and Quads, and same proportions in larger fonts.

Italic and Accents will not be sent with Roman fonts unless specially ordered. Smallest font of Italic furnished weighs 5 pounds. A pair of full-size cases holds 50 pounds of body type.

## ACCENTS FOR FOREIGN LANGUAGES.

Accents for the French, German and Spanish Languages are made for all body type and most of the job type shown in this book. Accents for the Polish, Bohemian, Hungarian, Danish, Norwegian, Swedish and Italian languages can be furnished for a large variety of body and job type. Accents are charged at the same rate as the fonts for which they are supplied.

## SPACES AND QUADS—SMALLEST JOB FONTS.

4½ Point . . \$1 70	11 Point . . \$0 60	24 Point . . \$0 60	48 Point . . \$0 80
5 Point . . 1 40	12 Point . . 60	28 Point . . 55	54 Point . . 1 10
5½ Point . . 1 00	14 Point . . 60	30 Point . . 50	60 Point . . 1 15
6 Point . . 65	15 Point . . 60	32 Point . . 50	72 Point . . 1 25
7 Point . . 65	16 Point . . 55	36 Point . . 55	84 Point . . 90
8 Point . . 65	18 Point . . 55	40 Point . . 60	96 Point . . 1 70
9 Point . . 60	20 Point . . 60	42 Point . . 60	120 Point . . 1 40
10 Point . . 55	22 Point . . 50	44 Point . . 60	

*Spaces and Quads of all sizes are also put up in 5-pound fonts, and sold at same rates as body type.*

## ALLOWANCE FOR OLD TYPE AND OTHER METALS.

Old type (clean and unmixed with other metals), electrotypes, leads and brass, delivered at foundry, will be taken at current prices in exchange for new type or printing material.

Customers sending in old metal are requested to mark their names on all packages, and to forward by mail a shipping receipt or bill of lading, with the net weight of each kind of material, as soon as shipment is made. Compliance with this request will aid in identifying shipments, and prevent errors. Ship as "old metal" to secure low freight rate.

**SPECIAL NOTICE.**—Zinc plates, metal containing zinc, or type and other plates mixed with zinc plates, and stereotype plates, will not be received at any price. Type, electrotype plates, leads and brass must be packed separately, as the value of each differs.



## AMERICAN POINT SYSTEM OF TYPE BODIES.

The purpose of the American point system of type bodies is to give a uniform standard to type, leads, furniture and brass rules, and this standard is based on a point which is one-twelfth of Pica bodywise. All type bodies being multiples of the point, it follows that justification can be made rapidly and accurately by using point-body leads or slugs. The engravings on this page show all point bodies except 54, 84, 96 and 120. The equivalent names of the old bodies are given on page 9.

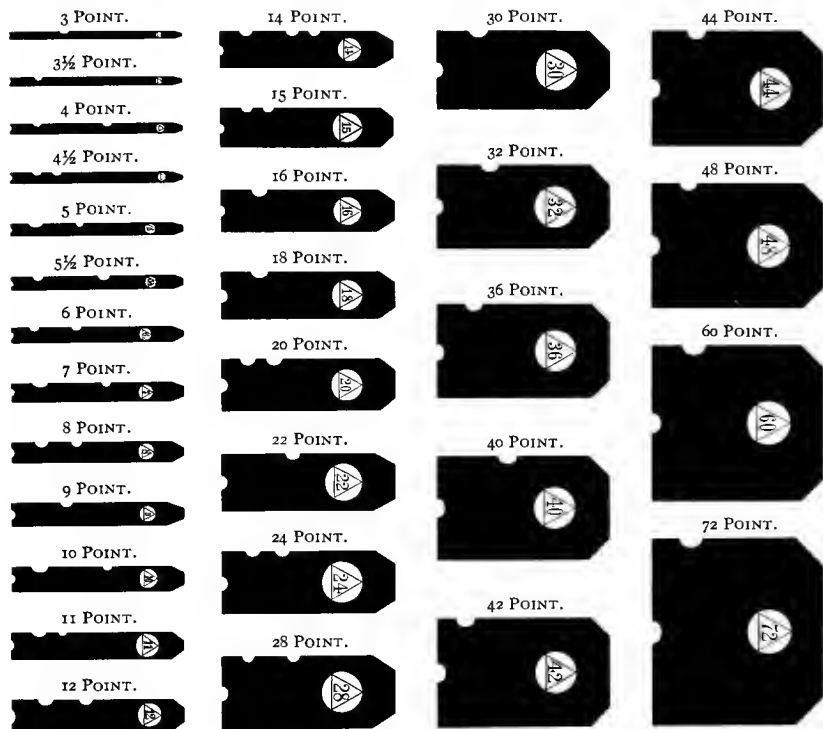

## ADVANTAGES OF THE AMERICAN POINT SYSTEM.

The advantages are all for the printer. The former policy of non-uniformity in type bodies, which existed in the United States until a decade ago and which still exists in Great Britain, was and is in the interests of the type founder, as it practically compelled the printer to select the standard of one type foundry and to adhere to it, because the products of two type founders could not be used together without great loss of time in justifying the differing standards. Now the entire products of all but one United States type foundry are interchangeable. In five years after the United States type founders commenced to adopt this uniform standard the old bodies had become almost obsolete. The American point system of type bodies was introduced by the Chicago and Philadelphia branches of the American Type Founders' Company, and all our type and material conform to it. Type on the point system is worth a great deal more to the printer than lack-of-system type.

# TIME=SAVING DATA FOR PRINTERS.

## STANDARD SIZES OF NEWSPAPERS.

The following tables of sizes are based upon the standard sizes of news paper, with columns 13 ems wide and 7-point column rule. The adoption of these sizes is advisable, especially in starting new papers, or putting in a new outfit, thereby gaining desirable uniformity :

### FOR FOLIO PAPERS

MATERIALS REQUIRED, ETC.	5-COLUMN FOLIO	8-COLUMN FOLIO	7-COLUMN FOLIO	8-COLUMN FOLIO	9-COLUMN FOLIO
For Standard Size of Paper . . . . .	20 × 26	22 × 30	24 × 35	26 × 40	29 × 44
Size of Matter for each Side, over all . . . . .	18 × 24½	20 × 28½	22 × 33½	24 × 37½	27 × 42½
Size of each Page of Matter . . . . .	11½ × 18	13½ × 20	15½ × 22	18½ × 24	20½ × 27
Size of Chases, over all, for each Side . . . . .	*21½ × 28½	23½ × 33½	25½ × 38	27½ × 42½	30½ × 47
Size of each Chase, inside . . . . .	19½ × 26½	14½ × 21½	17½ × 23½	19½ × 25½	21½ × 28½
Width of Cross-Bar . . . . .	1½	1½	1½	1½	1½
Width of Backs . . . . .	1	1	1	1	1
Width of Outside Iron . . . . .	1	1	1	1	1
Number of Chases required . . . . .	2 chases	2 pairs	2 pairs	2 pairs	2 pairs
Size of Side Sticks . . . . .	18½ × ½	20½ × ½	22½ × ½	24½ × ½	27½ × ½
Size of Foot Sticks . . . . .	11½ × ½	13½ × ½	15½ × ½	18½ × ½	20½ × ½
Number of Side and Foot Sticks required . . . . .	4 each	4 each	4 each	4 each	4 each
Length of 7-Point Column Rules, Inside Pages† . . . . .	17½	19½	21½	23½	25½
Total Number of Column Rules required . . . . .	16	20	24	28	32
Length of Head Rules and Slugs (Pica ems) . . . . .	67½	80½	94½	108½	121½
Number of Head Rules required . . . . .	5	5	5	5	5
Number of 6-Point Brass Head Slugs required . . . . .	7	7	7	7	7
Length of 3-Point Brass Leads for Side of Chases . . . . .	19	21	23	25	28
Length of 3-Point Brass Leads for Head of Chases . . . . .	12	14	17	19	21
Number of Side and Head Brass Leads required . . . . .	4 each	4 each	4 each	4 each	4 each

### FOR QUARTO PAPERS

MATERIALS REQUIRED, ETC.	4-COLUMN QUARTO	5-COLUMN QUARTO	6-COLUMN QUARTO	7-COLUMN QUARTO	8-COLUMN QUARTO
For Standard Size of Paper . . . . .	22 × 32	26 × 40	30 × 44	35 × 48	40 × 52
Size of Matter for each side, over all . . . . .	19½ × 30	24 × 38	28½ × 42	33½ × 46½	37½ × 50½
Size of each Page of Matter . . . . .	9 × 14	11 × 18	13½ × 20	15½ × 22	18½ × 24
Size of Chases, over all, for each Side . . . . .	24½ × 35	28½ × 43	33½ × 47	38 × 51½	42½ × 55½
Size of each Chase, inside . . . . .	15½ × 22½	19½ × 26½	21½ × 31	17½ × 23½	19½ × 25½
Width of Cross-Bar . . . . .	1½	1½	1½	1½	1½
Width of Backs . . . . .	1	1	1	1	1
Width of Outside Iron . . . . .	1	1	1	1	1
Number of Chases required . . . . .	2 pairs	2 pairs	2 pairs	4 pairs	4 pairs
Size of Side Sticks . . . . .	14½ × ½	18½ × ½	20½ × ½	22½ × ½	24½ × ½
Size of Foot Sticks . . . . .	8½ × ½	11½ × ½	13½ × ½	15½ × ½	18½ × ½
Number of Side and Foot Sticks required . . . . .	8 each	8 each	8 each	8 each	8 each
Length of 7-Point Column Rules, Inside Pages† . . . . .	13½	17	19½	21½	23½
Total Number of Column Rules required . . . . .	24	32	40	48	56
Length of Head Rules and Slugs (Pica ems) . . . . .	53½	67½	80½	94½	108½
Number of Head Rules required . . . . .	9	9	9	9	9
Number of 6-Point Brass Head Slugs required . . . . .	11	11	11	11	11
Length of 3-Point Brass Leads for Side of Chases . . . . .	15	19	21	23	25
Length of 3-Point Brass Leads for Head of Chases . . . . .	10	12	14	17	19
Number of Side and Head Brass Leads required . . . . .	8 each	8 each	8 each	8 each	8 each

\* For five-column folio use news chases.

† For four, five and six-column quartos, twin chases with bars. Size inside each chase (\* and †) includes the width of cross-bar. For all other sizes twin chases should be employed.

‡ The "size of chases over all" for seven and eight-column quartos, is the size of two pairs over all. These measurements, with the "size of matter for each side, over all," show the size press necessary to print one side of paper.

† Length of column rules for first page determined by size of heading, or say about two inches shorter than the others.

AMERICAN TYPE FOUNDERS COMPANY

## HOW TO ESTIMATE.

To ascertain the quantity of body type required for a publication, find the number of square inches and divide the same by four, and the quotient will be the approximate weight of type required; but, as it is impossible to set the cases entirely clear, it is necessary to add 25 per cent. to the weight of large fonts, and 33 1/3 per cent. to small fonts, to allow for dead letter.

### TABLE FOR NEWSPAPER ESTIMATES.

Showing the number of ems of the different sizes of newspaper type in a line, the number of lines necessary to make 1000 ems, and the length in inches; the number of ems in the regular lengths of columns, and number of leads required. There are 66 13-em 2-point leads in one pound.

ESTIMATED ON WIDTH OF STANDARD COLUMN, 13 EMS PICA.	5 1/2 POINT	8 POINT	7 POINT	8 POINT	8 POINT	10 POINT
Number ems in line . . . . .	28 3/4	26	22 3/4	19 1/2	17 1/2	15 1/2
Number lines in 1000 ems . . . . .	35 1/2	38 1/2	45	51 1/2	57 1/2	64 1/2
Number inches in 1000 ems . . . . .	2 2/3	3 1/4	4 3/8	5 1/3	5 7/8	9
4-Column Folio or Quarto } number ems {	5040	4325	3175	2465	1950	1610
5-Column Folio or Quarto } in column {	6505	5615	4115	3200	2525	2085
6-Column Folio or Quarto } . . . . . {	7180	6160	4515	3510	2770	2290
7-Column Folio or Quarto } . . . . . {	7900	6785	4970	3865	3050	2520
8-Column Folio, number ems in column . . . . .	8630	7410	5440	4220	3330	2755
9-Column Folio, number ems in column . . . . .	9310	8030	5885	4575	3615	2970
2 Point leads in 1000 ems of leaded matter . . . . .	26	29	35	41	47	54
2 Point leads in column, 4-column paper . . . . .	132	124	110	99	90	82
2 Point leads in column, 5-column paper . . . . .	170	160	142	128	116	107
2 Point leads in column, 6-column paper . . . . .	190	178	158	142	129	119
2 Point leads in column, 7-column paper . . . . .	209	196	174	157	142	131
2 Point leads in column, 8-column paper . . . . .	221	207	184	166	151	138
2 Point leads in column, 9-column paper . . . . .	266	250	222	200	182	167
Weight of 2-Point leads in 1000 ems of leaded matter . . . . .	6 oz.	7 oz.	8 1/2 oz.	10 oz.	11 1/2 oz.	13 oz.
Weight of 2-Point leads needed to lead 1000 ems of solid matter . . . . .	8 1/2 oz.	9 1/2 oz.	11 oz.	12 1/2 oz.	14 oz.	16 oz.

### RELATIVE PROPORTION OF TYPE BODIES.

Table showing the number of ems of different bodies contained in 1000 ems space of any given body. Also the weight and space occupied by 1000 ems of any body. Also the number of ems of any body, and the number of inches in one pound.

1000 EMS OF	3 1/2 POINT	4 1/2 POINT	5 POINT	5 1/2 POINT	6 POINT	7 POINT	8 POINT	8 POINT	10 POINT	11 POINT	12 POINT	WEIGHT	SQ. INCHES
3 1/2 Point . . . . .		605	490	495	341	250	192	151	122	101	85	10 oz.	2.36
4 1/2 Point . . . . .	1653		810	670	563	413	316	250	203	167	141	1 1/8 lbs.	3.91
5 Point . . . . .	2041	1235		827	695	510	391	309	250	207	174	1 1/4 lbs.	4.82
5 1/2 Point . . . . .	2469	1493	1210		840	617	473	373	303	250	210	1 1/2 lbs.	5.83
6 Point . . . . .	2940	1780	1440	1192		735	563	445	360	297	250	1 3/4 lbs.	6.94
7 Point . . . . .	4000	2420	1960	1620	1364		766	604	490	405	340	2 1/8 lbs.	9.44
8 Point . . . . .	5224	3160	2560	2116	1780	1306		790	640	529	445	2 1/2 lbs.	12.35
9 Point . . . . .	6612	4000	3240	2680	2252	1653	1266		810	670	564	3 1/8 lbs.	15.62
10 Point . . . . .	8164	4940	4000	3308	2780	2041	1563	1236		828	696	5 lbs.	19.29
11 Point . . . . .	9876	5972	4840	4000	3360	2469	1891	1492	1210		840	6 1/2 lbs.	23.30
12 Point . . . . .	11756	7112	5760	4760	4000	2939	2250	1778	1440	1190		7 1/2 lbs.	27.77
Ems in one lb.	1600	960	790	650	550	400	300	240	200	160	140		3.75
Ems in square inch . . . . .	223 1/2	256	207 1/2	171 1/2	144	105 1/2	81	64	51 1/2	42 1/2	36	4 1/2 oz.	

### NUMBER OF EMS IN ONE POUND OF TYPE.

Two by two inches (four square inches) solid type weighs approximately one pound :

5 Point . . . . .	EMS . 829	7 Point . . . . .	EMS . 423	10 Point . . . . .	EMS . 207
5 1/2 Point . . . . .	. 685	8 Point . . . . .	. 324	11 Point . . . . .	. 171
6 Point . . . . .	. 576	9 Point . . . . .	. 256	12 Point . . . . .	. 144

## AMERICAN TYPE FOUNDERS COMPANY

## TYPE STANDARDS.

The following is the standard adopted by the International Typographical Union. The basis of measurement is the lower-case alphabet, from a to z inclusive, and the ems used are the same body as the type measured :

<p>4½ Point . . . . . 18</p> <p>5 Point . . . . . 17</p> <p>5½ Point . . . . . 16</p> <p>6 Point . . . . . 15</p> <p>7 Point . . . . . 14</p>	<p>8 Point . . . . . 18</p> <p>9 Point . . . . . 17</p> <p>10 Point . . . . . 16</p> <p>11 Point . . . . . 15</p> <p>12 Point . . . . . 14</p>
---	--

## NUMBER OF EMS IN SQUARE INCHES OF TYPE.

[Copyrighted by D. Ramaley.]

SO. IN.	6 PT.	7 PT.	8 PT.	9 PT.	10 PT.	11 PT.	12 PT.	SO. IN.	6 PT.	7 PT.	8 PT.	9 PT.	10 PT.	11 PT.	12 PT.
1.	144	106	81	64	52	44	36	29.	4176	3074	2349	1856	1508	1276	1044
2.	288	212	162	128	104	88	72	30.	4320	3180	2430	1920	1560	1320	1080
3.	432	318	243	192	156	132	108	31.	4464	3286	2511	1984	1612	1364	1116
4.	576	424	324	256	208	176	144	32.	4608	3392	2592	2048	1664	1408	1152
5.	720	530	405	320	260	220	180	33.	4752	3498	2673	2112	1716	1452	1188
6.	864	636	486	384	312	264	216	34.	4896	3604	2754	2176	1768	1496	1224
7.	1008	742	567	448	364	308	252	35.	5040	3710	2835	2240	1820	1540	1260
8.	1152	848	648	512	416	352	288	36.	5184	3816	2916	2304	1872	1584	1296
9.	1296	954	729	576	468	396	324	37.	5328	3922	2997	2368	1924	1628	1332
10.	1440	1060	810	640	520	440	360	38.	5472	4028	3078	2432	1976	1672	1368
11.	1584	1166	891	704	572	484	396	39.	5616	4134	3159	2496	2028	1716	1404
12.	1728	1272	972	768	624	528	432	40.	5760	4240	3240	2560	2080	1760	1440
13.	1872	1378	1053	832	676	572	468	41.	5904	4346	3321	2624	2132	1804	1476
14.	2016	1484	1134	896	728	616	504	42.	6048	4452	3402	2688	2184	1848	1512
15.	2160	1590	1215	960	780	660	540	43.	6192	4558	3483	2752	2236	1882	1548
16.	2304	1696	1296	1024	832	704	576	44.	6336	4664	3564	2816	2288	1936	1584
17.	2448	1802	1377	1088	884	748	612	45.	6480	4770	3645	2880	2340	1980	1620
18.	2592	1908	1458	1152	936	792	648	46.	6624	4876	3726	2944	2392	2024	1650
19.	2736	2014	1539	1216	988	806	684	47.	6768	4982	3807	3008	2444	2068	1696
20.	2880	2120	1620	1280	1040	880	720	48.	6912	5088	3888	3072	2496	2112	1728
21.	3024	2226	1701	1344	1092	924	756	49.	7056	5194	3969	3136	2548	2156	1764
22.	3168	2332	1782	1408	1144	968	792	50.	7200	5300	4050	3200	2600	2200	1800
23.	3312	2438	1863	1472	1196	1012	828	51.	7344	5406	4131	3264	2652	2244	1836
24.	3456	2544	1944	1536	1248	1056	864	52.	7488	5512	4212	3328	2704	2288	1872
25.	3600	2650	2025	1600	1300	1100	900	53.	7632	5618	4293	3392	2756	2332	1908
26.	3744	2756	2106	1664	1352	1144	936	54.	7776	5724	4374	3456	2808	2376	1944
27.	3888	2862	2187	1728	1404	1188	972	55.	7920	5830	4455	3520	2860	2420	1980
28.	4032	2968	2268	1792	1456	1231	1108	56.	8064	5936	4536	3584	2912	2464	2016

## NUMBER OF LEADS TO THE POUND.

Table showing the approximate number of 2-point and 3-point leads contained in a pound. For 1-point leads, multiply the 2-point columns by 2. For 1½-point leads, multiply the 3-point columns by 2. For 6-point slugs, divide 3-point columns by 2.

EMS LONG	2 POINT	3 POINT	EMS LONG	2 POINT	3 POINT	EMS LONG	2 POINT	3 POINT	EMS LONG	2 POINT	3 POINT
3	288	192	15	57	38	27	31	21	39	22	15
4	216	144	16	54	36	28	30	20	40	21	14
5	168	112	17	51	34	29	30	20	41	21	14
6	144	96	18	48	32	30	29	19	42	20	14
7	123	82	19	45	30	31	28	19	43	20	13
8	108	72	20	42	28	32	27	18	44	19	13
9	96	64	21	40	27	33	26	17	45	19	13
10	84	56	22	39	26	34	25	17	46	18	12
11	78	52	23	37	25	35	24	16	47	18	12
12	72	48	24	36	24	36	24	16	48	18	12
13	66	44	25	34	23	37	23	15	49	17	11
14	61	41	26	33	22	38	22	15	50	17	11

## ROMAN NUMERALS.

I—1	VI—6	XI—11	XVI—16	XXX—30	LXXX—80	CCC—300	DCCC—800
II—2	VII—7	XII—12	XVII—17	XL—40	XC—90	CCCC—400	DCCCC—900
III—3	VIII—8	XIII—13	XVIII—18	L—50	C—100	D—500	M—1000
IV—4	IX—9	XIV—14	XIX—19	LX—60	CL—150	DC—600	
V—5	X—10	XV—15	XX—20	LXX—70	CC—200	DCC—700	

## AMERICAN TYPE FOUNDERS COMPANY

## APPROXIMATE NUMBER OF WORDS IN A SQUARE INCH.

In calculating the number of pages a manuscript will occupy, these figures may be used:

	WORDS TO SQ. IN.		WORDS TO SQ. IN.
22 Point . . . . .	4	9 Point, leaded . . . . .	21
18 Point, solid . . . . .	7	8 Point, solid . . . . .	32
14 Point, solid . . . . .	11	8 Point, leaded . . . . .	23
12 Point, solid . . . . .	14	7 Point, solid . . . . .	38
12 Point, leaded . . . . .	11	7 Point, leaded . . . . .	27
11 Point, solid . . . . .	17	6 Point, solid . . . . .	47
11 Point, leaded . . . . .	14	6 Point, leaded . . . . .	34
10 Point, solid . . . . .	21	5 Point, solid . . . . .	69
10 Point, leaded . . . . .	16	5 Point, leaded . . . . .	50
9 Point, solid . . . . .	28		

"Leaded," as here used, means an opening of lines with 2-point leads.

## USEFUL IN ORDERING SORTS.

The following table shows what each box in the type case will hold :

a c d i s m n h o u t r	boxes, each hold .	2 pounds.
f b l v g y p w	boxes, each hold .	15 ounces.
k j z x q and all figures	boxes, each hold .	6 ounces.
e	box holds . . . . .	3 pounds.
Caps and Small Caps	boxes, each hold .	5 ounces.

## AMERICAN POINT SYSTEM.

The following table gives the names of the old bodies and their designation by points :

POINT SYSTEM.	OLD BODIES.	POINT SYSTEM.	OLD BODIES.
3½ Point . . . . .	Brilliant.	24 Point . . . . .	2-line Pica.
4½ Point . . . . .	Diamond.	28 Point . . . . .	2-line English.
5 Point . . . . .	Pearl.	30 Point . . . . .	5-line Nonpareil.
5½ Point . . . . .	Agate.	32 Point . . . . .	4-line Brevier.
6 Point . . . . .	Nonpareil.	36 Point . . . . .	2-line Great Primer.
7 Point . . . . .	Minion.	40 Point . . . . .	Double Paragon.
8 Point . . . . .	Brevier.	42 Point . . . . .	7-line Nonpareil.
9 Point . . . . .	Bourgeois.	44 Point . . . . .	4-line Small Pica or Canon.
10 Point . . . . .	Long Primer.	48 Point . . . . .	4-line Pica.
11 Point . . . . .	Small Pica.	54 Point . . . . .	9-line Nonpareil.
12 Point . . . . .	Pica.	60 Point . . . . .	5-line Pica.
14 Point . . . . .	2-line Minion or English.	72 Point . . . . .	6-line Pica.
16 Point . . . . .	2-line Brevier.	84 Point . . . . .	7-line Pica.
18 Point . . . . .	Great Primer.	96 Point . . . . .	8-line Pica.
20 Point . . . . .	2-line Long Primer or Paragon	120 Point . . . . .	10-line Pica.
22 Point . . . . .	2-line Small Pica.		

## LABOR-SAVING LEADS AND SLUGS

2 Point or thicker, in fonts of graduated lengths, from 48 Points and upward.

<table border="0" style="width: 100%;"> <tr> <td style="width: 10%;">12 pound font</td> <td style="width: 10%; text-align: right;">\$3 00</td> <td style="width: 10%; vertical-align: top;">50 pound font</td> <td style="width: 10%; text-align: right;">\$12 50</td> </tr> <tr> <td>20 " "</td> <td style="text-align: right;">5 00</td> <td>100 " "</td> <td style="text-align: right;">25 00</td> </tr> <tr> <td>25 " "</td> <td style="text-align: right;">6 25</td> <td>Sorts, per pound</td> <td style="text-align: right;">25</td> </tr> </table>	12 pound font	\$3 00	50 pound font	\$12 50	20 " "	5 00	100 " "	25 00	25 " "	6 25	Sorts, per pound	25	
12 pound font	\$3 00	50 pound font	\$12 50										
20 " "	5 00	100 " "	25 00										
25 " "	6 25	Sorts, per pound	25										

## SHAVED LEADS AND SLUGS

		CUT TO ONE				CUT TO ONE	
		UNCUT	MEASURE			UNCUT	MEASURE
1 Point (12-to-Pica), per lb. . .		\$0 50	\$0 65	6 Point (Nonpareil), Slugs, per lb.			
1 1/2 " (10-to-Pica), " . . .		40	50	8 " (Brevier) " " . . .		}	\$0 16    \$0 18
1 3/4 " (8-to-Pica), " . . .		32	40	9 " (Bourgeois) " " . . .			
2 " (6-to-Pica), " . . .		16	18	10 " (Long Prim.) " " . . .			
3 " (4-to-Pica), " . . .		16	18	12 " (Pica) " " . . .			
4 " (3-to-Pica), " . . .		16	18	18 " (Great Prim.) " " . . .			

## METAL CORNER QUADS

These insure a better junction of mitered corners, by preventing them from slipping past each other.

6 Point, per set of four . . .	\$0 20	
12 " " " " . . .	20	
3 " Brass, per set of four . . .	25	

## COPPER ALLOY TAKE SLUGS

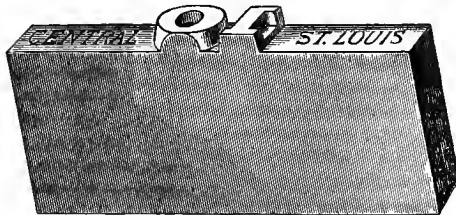

The only Take Slug cast in a mould in extra durable copper alloy metal. Better, cheaper and more durable than electrotyped slugs. Any number from 1 to 100, in this style figure only:

# 123456

Price, each, 15 cents

## ELECTROTYPED TAKE SLUGS

With Word, Letter or Figure . . .

\$0 25

## ANGULAR QUADS

These Quads, introduced by us, are for setting rules and lines at an angle. When there is occasion for their use they are invaluable time-savers.

They are of ordinary space and quad height.

Fonts, four of all sizes, \$1.50.

Price, per set of four:—

12 Point, \$0 20	48 Point, \$0 30
18 " " 20	60 " " 35
24 " " 20	72 " " 40
36 " " 25	

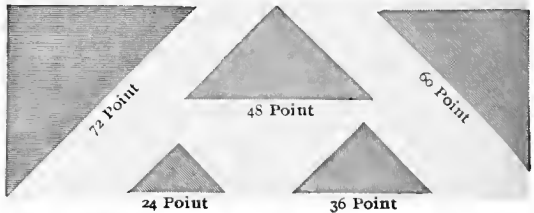

## CIRCULAR QUADS

Fonts, \$3.50

Each font is put up in a wooden box, containing four pieces each of twenty different curves. Each curve mortised as shown in examples.

## METAL FURNITURE

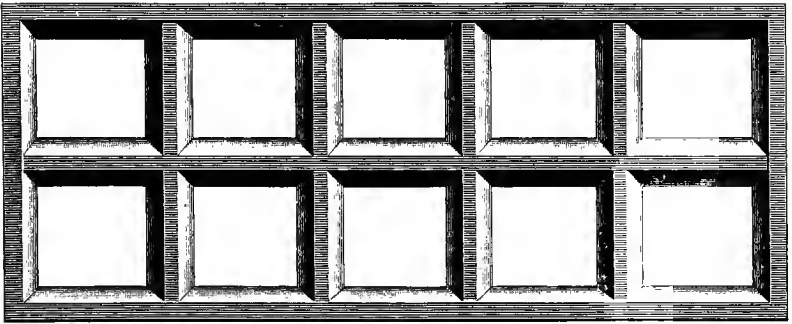

Put up in fonts containing the following sizes:  
2, 3, 4, 5, 6, 8 and 10 12-Point ems wide, and 4,  
5, 6, 8, 10, 12, 15, 20, 25, 30 and 50 12-Point ems  
long.

12 pound font . . . . .	\$3 00
25 " . . . . .	6 25
50 " . . . . .	12 50
100 " . . . . .	25 00

Sorts, 25 cents per pound.

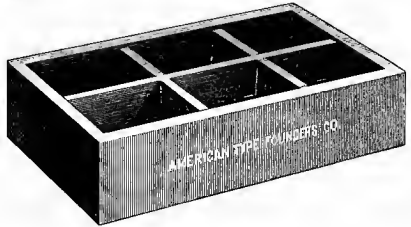

## LABOR-SAVING QUOTATION FURNITURE

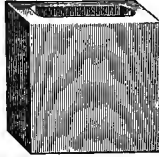

This Furniture is cast in a type mould,  
and is finished with the strictest regard  
for accuracy. The pieces are 4, 8, 12, 16  
and 20 12-Point ems in length, and 2, 3  
and 4 12-Point ems in width, quadrat  
height, with suitable spaces.

20 pound font . . . . .	\$5 00
40 " " . . . . .	10 00

Sorts to order, 2 x 4, 2 x 8, 2 x 12, 2 x 16, 2 x 20, 3 x 4, 3 x 8, 3 x 12, 3 x 16, 3 x 20, 4 x 4, 4 x 8, 4 x 12, 4 x 16,  
4 x 20 ems 12 Point, per pound, 25 cents.

## REVERSIBLE METAL FURNITURE

25 pound fonts . . . . .	\$6 25
50 " " . . . . .	12 50
75 " " . . . . .	18 75
100 " " . . . . .	25 00

Sorts to order, per pound,  
25 cents.

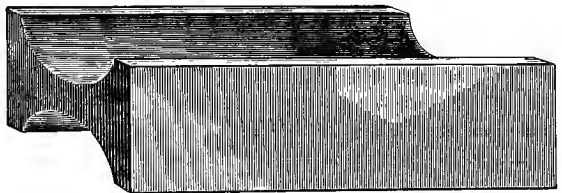

This Labor-Saving Reversible Furniture is our invention, and is the strongest and one of the  
most accurate in the world. It is made on the Point System of bodies, and is useful for blanking  
out and making up forms and for general imposition.

List of sizes furnished: 2, 3, 4, 5, 6, 8 and 10 ems Pica in width, and 4, 5, 6, 8, 10, 15, 20 and 25 ems  
Pica in length; also 2, 3, 4 and 5 ems in width by 50 ems in length. Fonts of 50 pounds or more in  
weight contain all of the above sizes.

AMERICAN TYPE FOUNDERS COMPANY

## BRASS DASH RULES

Cut to single newspaper column. Prices quoted are for columns 15 Pica ems wide and under.

No.	Style	EACH
No. 21.	_____	7 cts.
No. 22.	=====	7 cts.
No. 23.	~~~~~	7 cts.
No. 24.	=====	8 cts.
No. 25.	=====	8 cts.
No. 26.	=====	8 cts.
No. 27.	=====	8 cts.
No. 28.	=====	7 cts.
No. 29.	=====	7 cts.
No. 30.	~~~~~	7 cts.
No. 31.	=====	8 cts.
No. 32.	=====	8 cts.
No. 33.	=====	8 cts.
No. 34.	=====	8 cts.

## BRASS HEAD RULES

The following prices are for any Single, Double, Parallel or Triple Rule shown in this book:

12 in. and under, each	3 & 4 PT.		5 1/2 & 7 PT.	
	THICK	THICK	THICK	THICK
14 " " " "	.20	.25	.30	.35
17 " " " "	.25	.30	.35	.40
17 " " " "	.30	.35	.45	.50
19 " " " "	.35	.40	.50	.60
22 " " " "	.40	.50	.60	.70

No. 21.	4 Point.
No. 22.	3 Point.
No. 23.	4 Point.
No. 24.	4 Point.
No. 25.	4 Point.
No. 26.	5 Point.
No. 28.	5 1/2 Point.
No. 29.	5 Point.
No. 30.	6 Point.
No. 32.	5 Point.
No. 33.	6 Point.
No. 34.	7 Point.

## ADVERTISING RULES

Prices quoted are for columns 15 Pica ems wide and under.

No.	SINGLE COL. 4 cts.	DOUBLE COL. 6 cts.
No. 21.	4 cts.	6 cts.
No. 22.	4 cts.	6 cts.
No. 23.	5 cts.	8 cts.
No. 24.	5 cts.	8 cts.
No. 25.	5 cts.	8 cts.
No. 26.	6 cts.	10 cts.
No. 27.	6 cts.	10 cts.
No. 28.	6 cts.	10 cts.
No. 29.	6 cts.	10 cts.
No. 30.	7 cts.	11 cts.
No. 31.	7 cts.	11 cts.

## BRASS COLUMN RULES

SIZE	FACE LENGTH	8 PT.	7 PT.	8 PT.	10 PT.
4 Column	.133 1/4 in.	.35	.50	.55	.60
5 "	.173 1/4 in.	.40	.55	.60	.70
6 "	.193 1/4 in.	.45	.60	.65	.80
7 "	.213 1/4 in.	.50	.65	.70	.85
8 "	.233 1/4 in.	.50	.65	.70	.85
9 "	.253 1/4 in.	.55	.70	.80	.95
Each additional inch		.02	.03	.04	.05

Column Rules, nicked under for Combination Head Rules, 10 cents extra. Notched over and under for Perfecting presses, each 25 cents extra.

8 POINT      7 POINT      8 POINT      9 POINT      10 POINT



## BRASS LEADS AND SLUGS

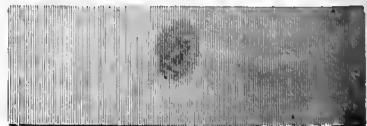

	PER POINT
1 Point, cut to one measure	.20
1 1/2 " " " "	.25
2 " " " "	.35
6 " and thicker, cut to one measure	.75
3 " in strips	.10
6 " " "	.20



# BRASS RULES

*In ordering Brass Rule it is important to state both No. and Initial of the style wanted*

ALL BRASS RULES, UNLESS OTHERWISE STATED, ARE MADE IN TWENTY-FOUR INCH STRIPS

NO.	BODY	PER FOOT
301 C	1 Point	\$0 05
303 C	1½ Point	6
304 C	2 Point	8
306 C	3 Point	12
307 C	4 Point	16
308 C	5 Point	20
309 C	5½ Point	22
310 C	6 Point	28
311 C	7 Point	32
312 C	8 Point	34
313 C	9 Point	38
314 C	10 Point	40
315 C	11 Point	45
316 C	12 Point	50
501 C	1 Point	5
502 C	1½ Point	6
503 C	2 Point	8
504 C	3 Point	12
505 C	4 Point	16
506 C	5 Point	20
507 C	6 Point	28
508 C	7 Point	32
509 C	8 Point	34
510 C	9 Point	38

NO.	BODY	PER FOOT
540 C	1½ Point	\$0 6
541 C	2 Point	8
542 C	3 Point	12
543 C	4 Point	16
544 C	5 Point	20
545 C	6 Point	28
546 C	7 Point	32
547 C	8 Point	34
548 C	9 Point	38
549 C	10 Point	40
550 C	11 Point	45
551 C	12 Point	50
552 C	1½ Point	6
553 C	2 Point	8
554 C	3 Point	12
555 C	4 Point	16
556 C	5 Point	20
557 C	6 Point	28
415 C	1 Point	\$0 06
416 C	1½ Point	6
417 C	2 Point	8
434 C	1 Point	6
435 C	1½ Point	6
436 C	2 Point	8

AMERICAN TYPE FOUNDERS COMPANY

## Specimens of Brass Rules

NO.	BODY	PER FOOT
317 C	1 Point	\$0 05
319 C	1½ Point	6
320 C	2 Point	8
322 C	3 Point	12
323 C	4 Point	16
324 C	5 Point	20
325 C	5½ Point	22
326 C	6 Point	28
327 C	7 Point	32
328 C	8 Point	34
329 C	9 Point	38
330 C	10 Point	40
331 C	11 Point	45
332 C	12 Point	50
333 C	2 Point	8
335 C	3 Point	12
336 C	4 Point	16
337 C	5 Point	20
339 C	6 Point	28
340 C	7 Point	32
341 C	8 Point	34
347 C	3 Point	12
348 C	4 Point	16
350 C	5½ Point	22
351 C	6 Point	28

NO.	BODY	PER FOOT
352 C	7 Point	\$0 32
353 C	8 Point	34
355 C	10 Point	40
359 C	3 Point	12
360 C	4 Point	16
361 C	5 Point	20
362 C	5½ Point	22
363 C	6 Point	28
364 C	7 Point	32
365 C	8 Point	34
366 C	9 Point	38
367 C	10 Point	40
368 C	11 Point	45
372 C	3 Point	12
373 C	4 Point	16
374 C	5 Point	20
375 C	5½ Point	22
376 C	6 Point	28
377 C	7 Point	32
378 C	8 Point	34
379 C	9 Point	38
380 C	10 Point	40
381 C	11 Point	45
382 C	12 Point	50

AMERICAN TYPE FOUNDERS COMPANY

## Specimens of Brass Rules

NO. 386 C	BODY 5 Point	PER FOOT \$0 20
388 C	6 Point	28
389 C	7 Point	32
390 C	8 Point	34
391 C	9 Point	38
392 C	10 Point	40
393 C	11 Point	45
397 C	5 Point	20
399 C	6 Point	28
400 C	7 Point	32
401 C	8 Point	34
402 C	9 Point	38
403 C	10 Point	40
408 C	5½ Point	22
409 C	6 Point	28
410 C	7 Point	32
411 C	8 Point	34
412 C	9 Point	38
413 C	10 Point	40
423 B	12 Point	65
424 B	18 Point	95

NO. 419 C	BODY 1 Point	PER FOOT \$0 11
421 C	1½ Point	12
422 C	2 Point	14
424 C	3 Point	18
425 C	4 Point	20
426 C	5 Point	24
427 C	5½ Point	28
428 C	6 Point	34
438 C	1 Point	11
440 C	1½ Point	12
441 C	2 Point	14
443 C	3 Point	18
444 C	4 Point	20
445 C	5 Point	24
446 C	5½ Point	28
447 C	6 Point	34
455 C	1½ Point	10
456 C	2 Point	12
457 C	3 Point	16
459 C	1½ Point	10
460 C	2 Point	12
462 C	3 Point	16
472 C	3 Point	18
473 C	3 Point	18
474 C	3 Point	18
476 C	1½ Point	14

AMERICAN TYPE FOUNDERS COMPANY

## Specimens of Brass Rules

NO.	BODY	PER FOOT
334 B	2 Point	\$0 12
335 B	3 Point	18
336 B	4 Point	22
337 B	5 Point	27
338 B	6 Point	32
339 B	8 Point	42
340 B	12 Point	65
341 B	15 Point	80
342 B	18 Point	95
343 B	24 Point	1 25
344 B	2 Point	12
345 B	3 Point	18
346 B	4 Point	22
348 B	6 Point	32
349 B	8 Point	42
350 B	12 Point	65
487 C	6 Point	36
489 C	6 Point	36
491 C	7 Point	40
492 C	8 Point	42
493 C	10 Point	48
494 C	12 Point	58

NO.	BODY	PER FOOT
500 B	2 Point	\$0 12
501 B	3 Point	18
502 B	4 Point	22
504 B	6 Point	32
505 B	8 Point	42
506 B	12 Point	65
523 B	2 Point	12
524 B	3 Point	18
525 B	4 Point	22
527 B	6 Point	32
528 B	8 Point	42
529 B	12 Point	65
634 B	12 Point	70
639 B	6 Point	50
642 B	6 Point	50
646 B	5 Point	27
647 B	6 Point	32
477 C	6 Point	36
479 C	3 Point	20
480 C	4 Point	22
482 C	4 Point	22
484 C	4 Point	22
485 C	8 Point	42
486 C	12 Point	58

AMERICAN TYPE FOUNDERS COMPANY

## Specimens of Brass Rules

NO.	BODY	PER FOOT
372 B	2 Point	\$0 12
373 B	3 Point	18
374 B	4 Point	22
376 B	6 Point	32
377 B	8 Point	42
378 B	12 Point	65
405 B	12 Point	65
406 B	18 Point	95
407 B	24 Point	1 25
435 B	12 Point	65
436 B	18 Point	95
563 B	6 Point	40
564 B	12 Point	70
565 B	18 Point	1 10
566 B	6 Point	40
567 B	8 Point	50
568 B	12 Point	70

NO.	BODY	PER FOOT
619 B	6 Point	\$0 40
620 B	6 Point	40
685 A	*12 Point	70
686 A	*12 Point	70
590 B	12 Point	70
591 B	24 Point	1 25
592 B	36 Point	1 75
593 B	6 Point	40
594 B	12 Point	70
595 B	15 Point	90
596 B	24 Point	1 25
617 B	24 Point	1 25
618 B	24 Point	1 25
625 B	27 Point	1 40

*\*Nos. 685A and 686A are supplied in 12-inch strips.*

**AMERICAN TYPE FOUNDERS COMPANY**

# Labor-Saving Brass Rule

Labor-Saving Brass Rules are cut in length to Twelve-point body, the equivalent of Pica, unless otherwise ordered, and are graduated by ems and ens. Fonts furnished from any Single, Double, Parallel and Triple Rule shown

No 417C  
2 POINT

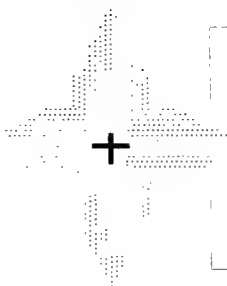

No 304C

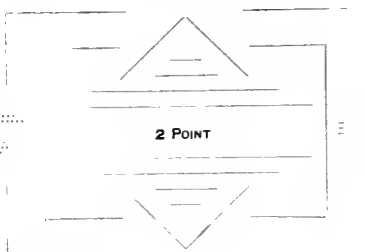

No 436C  
2 POINT

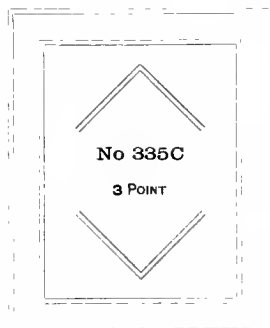
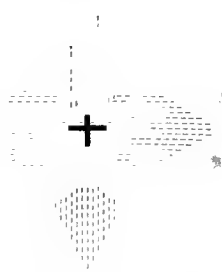

No 335C  
3 POINT

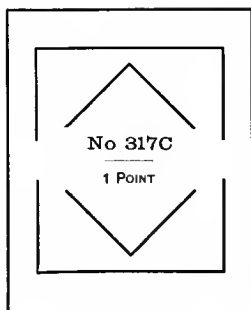

No 317C  
1 POINT

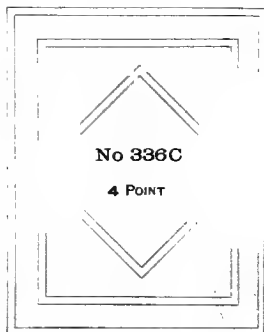

No 336C  
4 POINT

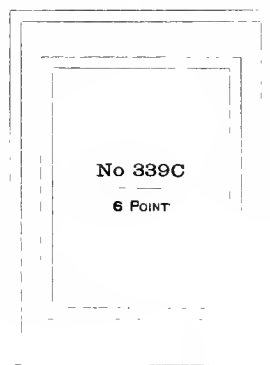

No 339C  
6 POINT

No 359C

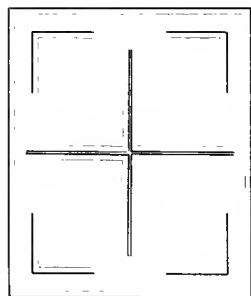

3 POINT

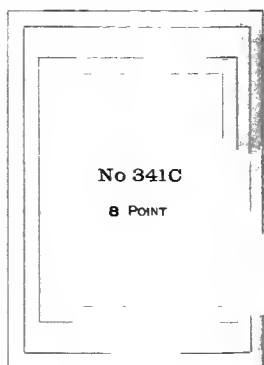

No 341C  
8 POINT

## Prices per Font

BODY	NO.	WHOLE	HALF	QUARTER	BODY	NO.	WHOLE	HALF	QUARTER
2 POINT	304C	\$11 25	\$5 90	\$3 05	8 POINT	341C	\$18 30	\$8 05	\$3 95
1 POINT	317C	8 15	5 00	3 10	3 POINT	359C	11 50	6 70	3 50
3 POINT	335C	11 50	6 70	3 50	2 POINT	417C	5 45	3 05	
4 POINT	336C	15 40	6 35	4 30	2 POINT	436C	5 45	3 05	
6 POINT	339C	12 20	6 75	3 50					

AMERICAN TYPE FOUNDERS COMPANY

# Labor-Saving Brass Rule

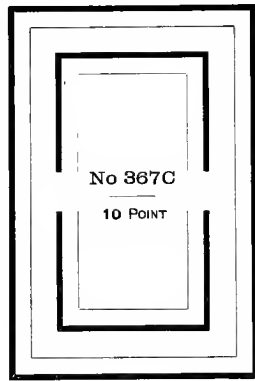
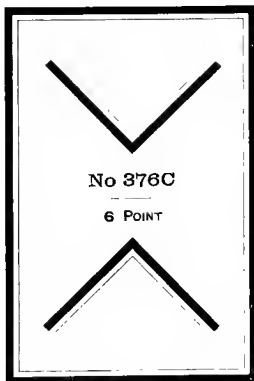
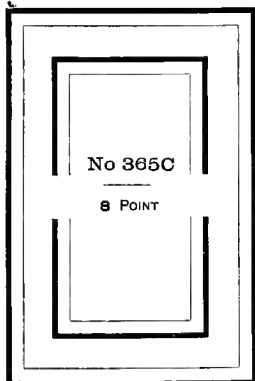
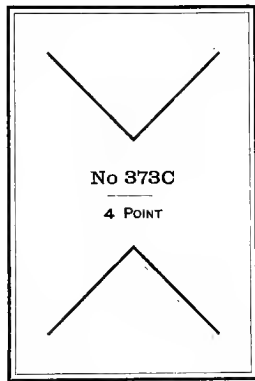
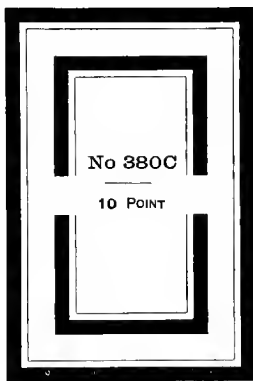
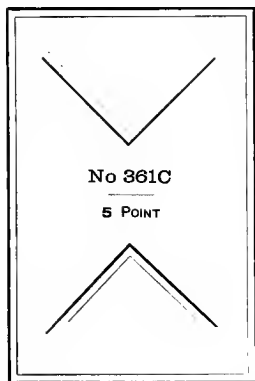
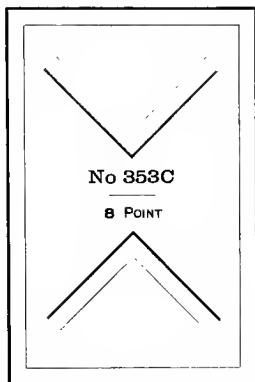
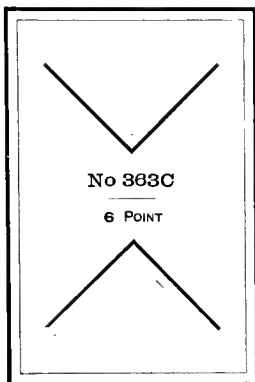
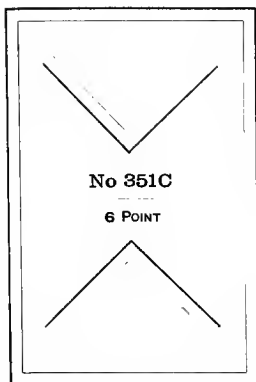

## Prices per Font

BODY	NO.	WHOLE	HALF	QUARTER	BODY	NO.	WHOLE	HALF	QUARTER
6 POINT	3510	\$12 20	\$8 75	\$3 50	10 POINT .	367C	\$15 75	\$8 85	\$3 50
8 POINT	3530	16 30	8 05	3 95	4 POINT .	373C	15 40	8 35	4 30
5 POINT	3610	11 55	8 20	3 40	8 POINT .	376C	12 20	6 75	3 50
8 POINT	3630	12 20	8 75	3 50	10 POINT .	380C	15 75	6 85	3 50
8 POINT	3650	16 30	8 05	3 95					

AMERICAN TYPE FOUNDERS COMPANY

# Brass Dashes

— 0 —

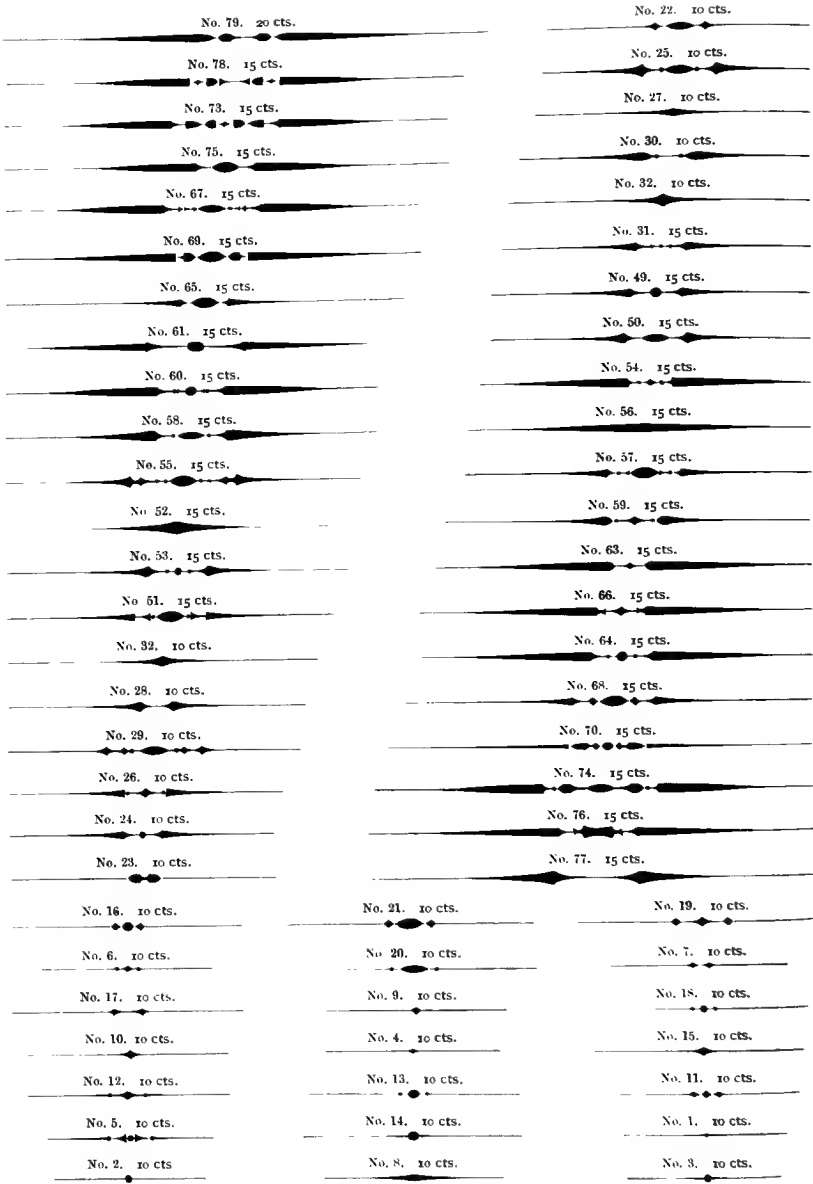

*Specimens of larger Dashes furnished upon application. The smaller sizes cut to any length for News Columns.*

**AMERICAN TYPE FOUNDERS COMPANY**



# Brass Circles and Ovals

Made to order in Single, Double, Parallel, Dotted, or Waved Rule, at same prices

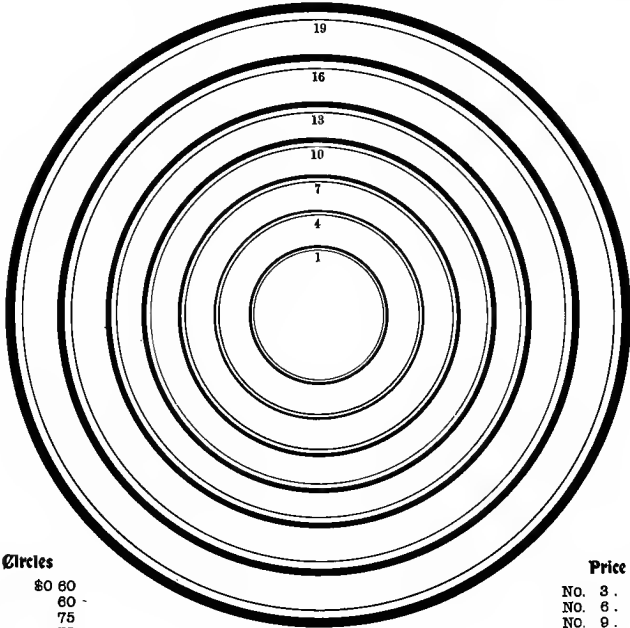

## Price of Circles

NO. 1	\$0 60
NO. 4.	60
NO. 7.	75
NO. 10.	75
NO. 13.	75
NO. 16.	1 00
NO. 19.	1 25

## Price of Ovals

NO. 3.	\$0 90
NO. 6.	90
NO. 9.	1 00
NO. 12.	1 00
NO. 15.	1 25
NO. 18.	1 50

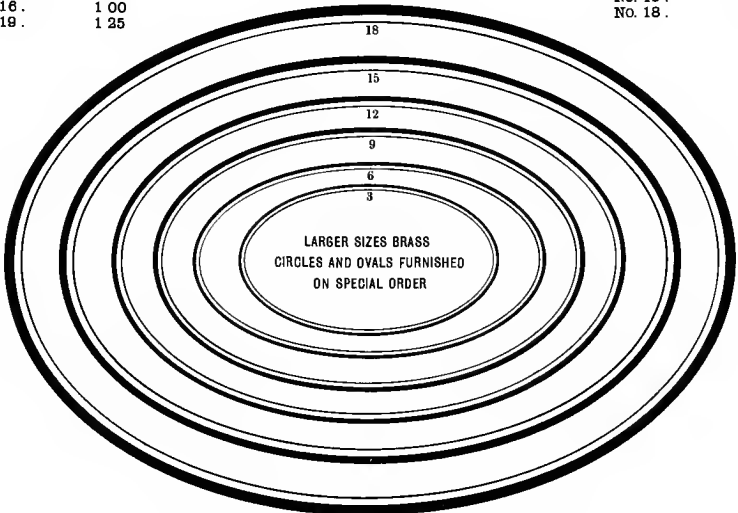

AMERICAN TYPE FOUNDERS COMPANY

# Brass Braces

COMPLETE SET \$5 6

No. 32. 30 cts.

No. 31. 30 cts.

No. 38. 12 c.

No. 30. 30 cts.

No. 37. 12 c.

No. 29. 30 cts.

No. 36. 12 c.

No. 28. 30 cts.

No. 35. 12 c.

No. 27. 25 cts.

No. 34. 12 cts.

No. 26. 25 cts.

No. 33. 12 cts.

No. 25. 25 cts.

No. 1. 12 cts.

No. 24. 25 cts.

No. 2. 12 cts.

No. 23. 25 cts.

No. 3. 12 cts.

No. 22. 18 cts.

No. 4. 12 cts.

No. 21. 18 cts.

No. 5. 12 cts.

No. 20. 18 cts.

No. 6. 12 cts.

No. 19. 18 cts.

No. 7. 12 cts.

No. 18. 18 cts.

No. 8. 12 cts.

No. 17. 15 cts.

No. 9. 12 cts.

No. 16. 15 cts.

No. 10. 12 cts.

No. 15. 15 cts.

No. 11. 15 cts.

No. 14. 15 cts.

No. 12. 15 cts.

No. 13. 15 cts.

## New Metal Braces

PRICE 5 CENTS EACH

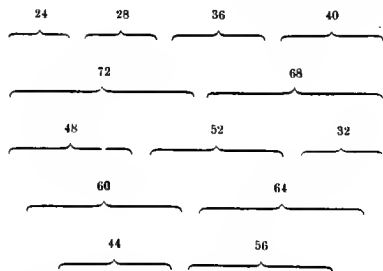

On 6 Point body. Cast in any lengths as per specimens, from 24 Point to 72 Point.

## 6 Point Braces and Dashes

No 2

PRICE PER FOOT \$1 25

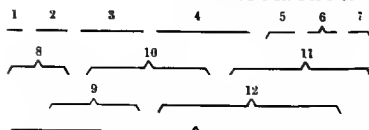

Nos. 8 to 12 are complete; Nos. 1 to 7 are for piecing.

## 6 Point Metal Braces

PRICE PER FOOT \$1 00

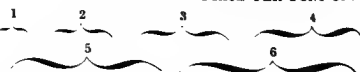









AMERICAN TYPE FOUNDERS COMPANY

# Labor-Saving Brass Leaders

(Hyphen or Dotted) from 12 Points to 216 Points in length

5 Point . . . per lb. \$1.60	7 Point . . . per lb. \$1.60	10 Point . . . per lb. \$1.50
5½ " " " 1.60	8 " " " 1.60	11 " " " 1.40
6 " " " 1.60	9 " " " 1.50	12 " " " 1.40

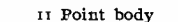
5 Point body	Faces
	.....
5½ Point body	.....
	.....
6 Point body	.....
	.....
7 Point body	.....
	.....
8 Point body	.....
	.....

9 Point body	Faces
	.....
10 Point body	.....
	.....
11 Point body	.....
	.....
12 Point body	.....
	.....

When ordering, be particular to state the style of Leader (whether Dotted or Hyphen) as well as the face of the type with which the Leaders are to be used

# Copper Alloy Fine-Dot Leaders

8 POINT PER POUND . . . . \$0 84	8 POINT PER POUND . . . . \$0 52	11 POINT PER POUND . . . . \$0 44
7 POINT PER POUND . . . . 56	9 POINT PER POUND . . . . 48	12 POINT PER POUND . . . . 42
	10 POINT PER POUND . . . . 46	

These are used as a substitute for Dotted Brass Rule, and save the time spent in justification. Made on 6, 7, 8, 9, 10, 11 and 12 Point bodies. When ordering, state the type (if our make) they are required to line with, or send sample cap "H" or lower-case "m." Put up in any size font required. The following example shows Fine-Dot Leaders lining with 8 Point Law Italic No. 40:

Name .....

Post Office.....

County..... State.....

We, the undersigned, of the City of....., and State of....., engaged in the business of....., at No.....Street, in said City, do hereby acknowledge our total inability to manufacture.....which will not give satisfaction.

### Perforating Rules

700B, Brass. 2 Point.	Per foot, 15 cts.
701B, Brass. 3 Point.	Per foot, 18 cts.
710B, Steel. 17 teeth to 1 in.	Per foot, 50 cts.
711B, Steel. 12 teeth to 1 in.	Per foot, 50 cts.
712B, Steel. 8½ teeth to 1 in.	Per foot, 50 cts.

### Brass Scoring Rules

2 Point, per foot, .08	4 Point, per foot, .16
3 " " " .12	6 " " " .28

### Steel Cutting Rules

2 Point, regular, per foot. . . . .	.20
2 " bright and hard, per foot . . . .	.30
3 " regular, per foot . . . . .	.30
6 " " " " " " " " . . . . .	.50

### Brass Space Rule

1 Point	per pound, \$3.50
1½ " "	2.75
2 " "	2.00

# BOOKBINDERS' BRASS TYPE, BORDERS AND ORNAMENTS

A special Specimen Book showing the various styles of Brass Type, Borders and Ornaments made by the American Type Founders' Company will be sent on application. The following series, or parts of them, shown in this Specimen Book, are made in Solid Brass:

	PAGE		PAGE
Antique Cond. No. 45 (Caps) . . . . .	130	Lightface Condensed No. 45 . . . . .	113
Antique Extra Cond. No. 42 (Caps) . . . . .	131	Lining Gothic No. 44 (Caps) . . . . .	141
Art Gothic . . . . .	248	Modern Text No. 40 . . . . .	335
Atlanta . . . . .	230	Mural . . . . .	240
Celtic No. 42 . . . . .	182	Norman Condensed . . . . .	182
Extra Condensed No. 45 (Caps) . . . . .	120	Novelty Script . . . . .	302
Facade . . . . .	241	Old Style Bold (Caps) . . . . .	93
French Old Style (Caps) . . . . .	66, 67	Old Style Extended (Caps) . . . . .	92
Gothic Condensed No. 44 (Caps) . . . . .	161	Old Style No. 43 . . . . .	88
Gothic Extra Cond. No. 42 (Caps) . . . . .	162	Old Style Condensed No. 42 . . . . .	89
Lafayette (Caps) . . . . .	222	Old Style No. 44 . . . . .	88
Lightface No. 43 . . . . .	114	Victoria . . . . .	231
Lightface No. 44 . . . . .	115	Yonkers . . . . .	331

Also, a large assortment of beautiful Borders, Bands and Ornaments.

**THE STAR-SPANGLED BANNER**

FRANCIS SCOTT KEY. 1814

*Voices in unison*

Oh, say, can you see, by the dawn's early light, What so proud-ly we hail'd at the twilight's last gleaming, Whose stripes and bright stars, thro' the perilous fight, O'er the ramparts we

DECEMBER 15, 1897.

**MUSIC TYPE**

In addition to regular fonts of Music Type, we now put up fonts one-half the regular size, as follows:

	Per lb.	Smallest font	Price per font
Excelsior	\$3.60 .	. 15 pounds .	\$54.00
Diamond	3.20 . . .	. 30 " . . .	96.00
Agate . . .	2.40 . . . . .	. 30 " . . . . .	72.00
Nonpareil . . . . .	2.00 . . . . .	. 30 " . . . . .	60.00
Tonic Sol-fa, 8 Point .	1.00 . . . . .	. 25 " . . . . .	25.00
Tonic Sol-fa, 10 Point .	0.82 . . . . .	. 25 " . . . . .	20.50

**Excelsior Music No 3**

PER LB. \$3 60  
Weight of smallest font, 30 lbs.

*Novello, or English Note*

**OLD HUNDRED**

ISAAC WATTS

G. FRANC

Be fore Je - ho - vah's aw - ful throne, Ye na - tions! bow with sa - cred joy:

# Diamond Music No 1

PER LB. \$3 20  
Weight of smallest font, 60 lbs.

## HOME, SWEET HOME

BISHOP

*With expression*

Mid pleas-ures and pal a - ces though we may roam, Be it ev - er so

The first system of musical notation for 'Home, Sweet Home' consists of a vocal line and a piano accompaniment line. The vocal line is in a 2/4 time signature with a key signature of one flat (B-flat). It begins with a quarter rest followed by a quarter note G4, then a series of eighth and quarter notes: A4, Bb4, A4, G4, F4, E4, D4, C4. The piano accompaniment starts with a quarter rest followed by a quarter note G3, then a series of eighth and quarter notes: A3, Bb3, A3, G3, F3, E3, D3, C3. The lyrics are: 'Mid pleas-ures and pal a - ces though we may roam, Be it ev - er so'.

*cres.*

hum - ble, there's no place like home! A charm from the skies seems to hal - low us

The second system of musical notation continues the vocal and piano lines. The vocal line continues with a quarter note C4, then a series of eighth and quarter notes: Bb4, A4, G4, F4, E4, D4, C4. The piano accompaniment continues with a series of eighth and quarter notes: A3, Bb3, A3, G3, F3, E3, D3, C3. The lyrics are: 'hum - ble, there's no place like home! A charm from the skies seems to hal - low us'.

# Diamond Music No 2

PER LB. \$3 20  
Weight of smallest font, 60 lbs.

## ANNIE LAURIE

SCOTCH BALLAD

*Tenderly*

Max wel - ton's braes are bon nie, Where ear ly fa's the dew,

The first system of musical notation for 'Annie Laurie' consists of a vocal line and a piano accompaniment line. The vocal line is in a 4/4 time signature with a key signature of one flat (B-flat). It begins with a quarter note G4, then a series of quarter notes: A4, Bb4, A4, G4, F4, E4, D4, C4. The piano accompaniment starts with a quarter note G3, then a series of quarter notes: A3, Bb3, A3, G3, F3, E3, D3, C3. The lyrics are: 'Max wel - ton's braes are bon nie, Where ear ly fa's the dew,'.

And 'twas there that An nie Lau - rie Gave me her prom - ise true,

The second system of musical notation continues the vocal and piano lines. The vocal line continues with a quarter note C4, then a series of quarter notes: Bb4, A4, G4, F4, E4, D4, C4. The piano accompaniment continues with a series of quarter notes: A3, Bb3, A3, G3, F3, E3, D3, C3. The lyrics are: 'And 'twas there that An nie Lau - rie Gave me her prom - ise true,'.

AMERICAN TYPE FOUNDERS COMPANY

# Diamond Music No 3

PER LB \$3 20  
Weight of smallest font, 60 lbs.

## AULD LANG SYNE

ROBERT BURNS

*p* *Slow*

Should auld ac- quaint- ance be for- got, And nev- er brought to mind?

The first system of musical notation for 'Auld Lang Syne' consists of a vocal line and a piano accompaniment line. The vocal line is in treble clef with a key signature of one sharp (F#) and a 4/4 time signature. It begins with a piano (*p*) and slow (*Slow*) marking. The lyrics are: "Should auld ac- quaint- ance be for- got, And nev- er brought to mind?". The piano accompaniment is in bass clef with the same key signature and time signature, starting with a piano (*p*) marking.

Should auld ac- quaint- ance be for- got, And days of auld lang syne?

The second system of musical notation continues the vocal line and piano accompaniment. The lyrics are: "Should auld ac- quaint- ance be for- got, And days of auld lang syne?".

# Diamond Music No 4

PER LB \$3 20  
Weight of smallest font, 60 lbs.

*Novello, or English Note*

## WATCH ON THE RHINE

WILHELM

There swells a cry as thun- ders crash, As clash of swords and break- ers dash; To

The first system of musical notation for 'Watch on the Rhine' consists of a vocal line and a piano accompaniment line. The vocal line is in treble clef with a common time signature (C). It begins with the lyrics: "There swells a cry as thun- ders crash, As clash of swords and break- ers dash; To". The piano accompaniment is in bass clef with a common time signature (C) and includes various musical symbols like %.

Rhine, to Rhine, to the Ger- man Rhine, Who will pro- tect thee riv- er mine?

The second system of musical notation continues the vocal line and piano accompaniment. The lyrics are: "Rhine, to Rhine, to the Ger- man Rhine, Who will pro- tect thee riv- er mine?".

AMERICAN TYPE FOUNDERS COMPANY

# Agate Music No 3

VIVA L'AMERICA, HOME OF THE FREE

PER LB. \$2 40  
Weight of smallest font, 60 lbs.

H. MILLARD

Musical score for 'Viva l'America, Home of the Free' by H. Millard. The score is written for piano in 6/8 time. It features a treble and bass clef with a key signature of one sharp (F#). The piece is marked 'Marziale' and 'ff' (fortissimo). The score includes several triplet markings (indicated by a '3' above the notes) and a 'Ped.' (pedal) marking. The piece concludes with a 'Man.' (meno) marking and a dynamic of 'p' (piano).

# Nonpareil Music No 3

EVER BE HAPPY

PER LB. \$2 00  
Weight of smallest font, 60 lbs.

BALFE

Musical score for 'Ever Be Happy' by Balfe. The score is written for piano in 6/8 time. It features a treble and bass clef with a key signature of one sharp (F#). The piece is marked 'Allegretto Moderato' and 'mf' (mezzo-forte). The score includes several triplet markings (indicated by a '3' above the notes) and a 'Ped.' (pedal) marking. The piece concludes with a 'Man.' (meno) marking and a dynamic of 'p' (piano).



# Small Fonts of Porson and Heavyface Greek

PLAN OF PATENTED GREEK CASE

A	B	Γ	Δ	E	Z	H	α	̄	̅	̆	̇	̈	̉	̊	̋	̌	̍	̎	̏	̐	
Θ	I	K	Λ	M	N	Ξ	έ	ε̇	ε̈	ε̉	ε̊	ε̋	ε̌	ε̍	ε̎	ε̏	ε̐	ε̑	ε̒	ἐ	
O	Π	Ρ	Σ	Τ	Υ	Φ	ή	η̇	η̈	η̉	η̊	η̋	η̌	η̍	η̎	η̏	η̐	η̑	η̒	ἠ	
Χ	Ψ	Ω	Ϝ	ϝ	Ϟ	ϟ	ί	ι̇	ϊ	ι̉	ι̊	ι̋	ι̌	ι̍	ι̎	ι̏	ι̐	ι̑	ι̒	ἰ	
α	β	γ	δ	ε	ζ	η	ό	ο̇	ο̈	ο̉	ο̊	ο̋	ο̌	ο̍	ο̎	ο̏	ο̐	ο̑	ο̒	ὀ	
θ	ι	κ	λ	μ	ν	ξ	ύ	υ̇	ϋ	υ̉	υ̊	υ̋	υ̌	υ̍	υ̎	υ̏	υ̐	υ̑	υ̒	ὐ	
ο	π	ρ	σ	τ	υ	φ	ώ	ω̇	ω̈	ω̉	ω̊	ω̋	ω̌	ω̍	ω̎	ω̏	ω̐	ω̑	ω̒	ὠ	
χ	ψ	ω	ς	ϛ	Ϝ	ϝ	·	˘	˙	˚	˛	˜	˝	˞	˟	ˠ	ˡ	ˢ	ˣ	ˤ	
χ	ψ	ω	ς	ϛ	Ϝ	ϝ	α	ε	η	ο	υ	ω	-	-	-	-	-	-	-	-	-

Price of Greek Case, full size, \$2.00

Sorts are charged at pound rates in quantities; the minimum charge is 75 cents net. For school examination papers, paragraphs, quotations, etc., these small fonts will prove most useful.

The want of a small font of Greek type is often felt in printing offices. To meet this need, the American Type Founders Company now puts up small and complete assortments (to include all of the characters used in the largest fonts of Porson Greek), together with a case for same of its own devising. No variations in the assortment or weight of these small fonts will be made. For prices see specimens. Regular fonts of 50 pounds and upwards will be furnished at pound prices.

## List of Porson and Heavyface Greek Letters and Accents

1 A	15 O	29 ε	43 ς	144 δ	65 η	74 ι	138 ι̇	96 υ	162 ω̇	KERNS	116
2 B	16 Π	30 ζ	44 τ	55 δ	66 η̇	75 ι̇	139 ϊ	97 υ̇	163 ω̈	103 α	119
3 Γ	17 Ρ	31 η	45 υ	56 δ	67 η̈	76 ϊ	84 ι̊	168 ϋ	160 ω̊	104 ε	120
4 Δ	18 Σ	32 θ	46 φ	166 ᾱ	68 η̉	79 ι̉	87 ο̇	169 υ̉	161 ω̉	105 η	117
5 E	19 Τ	33 ι	47 χ	140 ρ	147 η̊	76 ι̊	88 ο̈	156 υ̊	165 ω̊	106 ο	118
6 Z	20 Υ	34 κ	48 ψ	58 ε̇	148 η̋	77 ι̋	89 ο̉	157 υ̋	164 ω̋	107 υ	122
7 H	21 Φ	35 λ	49 ω	59 ε̈	149 η̌	80 ι̌	90 ο̊	158 υ̌	142 φ	108 ω	121
8 Θ	22 Χ	36 μ	133 Ϝ	60 ε̉	150 η̍	81 ι̍	92 ο̋	98 υ̋	101 ϛ	109 ρ	126
9 I	23 Ψ	37 ν	50 α̅	61 ε̊	151 η̎	85 ι̎	155 ο̌	167 υ̌	102 ϛ̇	110 η̇	127
10 K	24 Ω	38 ξ	51 ᾰ	63 ε̋	70 η̏	86 ι̏	91 ο̍	99 ω̍	POINTS	111 φ	134
11 Λ	25 α	39 ο	52 α̇	146 ε̌	141 η̐	82 ι̐	154 ο̎	136 ω̎	129	112	135
12 M	26 β	40 π	143 α̈	62 ε̍	71 ι̑	83 ι̑	93 ο̏	100 ω̏	130	113	125
13 N	27 γ	41 ρ	54 α̉	145 ε̎	72 ι̒	152 ι̒	94 υ̍	159 ω̍	131	114	124
14 Ξ	28 δ	42 σ	57 α̊	64 ἠ	73 ἰ	153 ἰ	95 υ̎	137 ω̎	132	115	123

When ordering sorts quote number as well as letter. No sorts for less than 75 cents, net.

## Information Respecting Greek Type

The Greek Alphabet contains twenty-four letters: seventeen consonants and seven vowels. The only duplicate characters are Ϝ and Ϟ, the latter being used as a final letter only. The accents and breathings are:

˘ Smooth	˙ Rough	˚ Smooth acute	˛ Rough grave	˜ Diæresis
˘ Acute	˙ Grave	˚ Smooth grave	˛ Smooth circumflex	˜ Diæresis acute
˘ Circumflex		˚ Rough acute	˛ Rough circumflex	˜ Diæresis grave

The sign of interrogation is made by a [ι]; the colon by an inverted full point [-]; the other points are the same as in English. The kerned letters are seldom required, and are only supplied to a font to make up any deficiency in accented sorts. Accented caps have the accent before them, thus [ρ̃Ω]. The figures used are the same as in English and are not put up with job fonts.

Compositors should bear in mind that no accent can be placed over any other than one of the last three syllables of a word. The grave accent never occurs but on the last syllable; this being the case, the rough grave [˙] and smooth grave [˘] can only be used for a few monosyllables. No vowels can have a breathing excepting at the beginning of the word, and ϛ is the only consonant marked by a breathing. Almost every word has an accent, but very few more than one.

AMERICAN TYPE FOUNDERS COMPANY

## Porson Greek

*Porson Greek cast to order in fonts of 50 lbs. and upwards*

8 POINT

JOB FONT #7 50

Τοῦ δ' ἐπιγυγνομένου θέρους αἱ μὲν ἐνιαύσιοι σπονδαὶ διελέλυτο μέχρι Πυθίων· καὶ ἐν τῇ ἐκεχειρίᾳ οἱ Ἀθηναῖοι Δηλίου ἀνέστησαν ἐκ Δήλου, ἡγησάμενοι κατὰ παλαιὰν τινα αἰτίαν οὐ καθαρὸς ὄντας ἱερῶσθαι, καὶ ἅμα ἑλλιπὲς σφίσις εἶναι τοῦτο τῆς καθάρσεως, ἢ πρότερόν μοι δεδῆλωται ὡς ἀνελόντες τὰς θήκας τῶν τεθνεώτων ὀρθῶς ἐνόμισαν ποιῆσαι. καὶ οἱ μὲν Δήλιοι Ἀτραμύττειον Φαρνάκου δόντος αὐτοῖς ἐν τῇ Ἀσίᾳ ἔκκησαν, οὕτως ὡς ἕκαστος ὄρμητο. Κλέων δὲ Ἀθηναῖος πείσας ἐς τὰ ἐπὶ Θράκης χωρία ἐξέπλευσε μετὰ τὴν ἐκεχειρίαν, Ἀθηναίων μὲν ὀπλίτας ἔχων διακοσίους καὶ χιλίους καὶ ἵππεας τριακοσίους, τῶν δὲ ξυμμάχων πλείους, ναῦς δὲ

*8 Point Porson Greek cast on 9 Point to order in fonts of 50 lbs. and upwards*

10 POINT

JOB FONT #7 50

Ἄλλο δὲ στράτευμα αὐτῷ συνελέγετο ἐν Χερρονήσῳ τῇ κίταντιπέρας Ἀβύδου τόνδε τὸν τρόπον. Κλέαρχος Λακεδαιμόνιος φυγὰς ἦν· τούτῳ συγγενόμενος ὁ Κῦρος ἠγάσθη τε αὐτὸν καὶ δίδωσιν αὐτῷ μυρίους δυρεικούς. ὁ δὲ λαβὼν τὸ χρυσίον στράτευμα συνέλεξεν ἀπὸ τούτων τῶν χρημάτων, καὶ ἐπολέμει ἐκ Χερρονήσου ὀρμώμενος τοῖς Ἐπαξί τοῖς ὑπὲρ Ἑλλησποντον οἰκοῦσι, καὶ ὠφέλει τοὺς Ἑλληνας. ὥστε καὶ χρήματα συνεβάλλοντο αὐτῷ εἰς τὴν τροφὴν τῶν στρατιωτῶν αἱ Ἑλλησποντιακαὶ πόλεις ἐκούσαι. τοῦτο δ' αὖ οὕτω τρεφόμενον ἐλάνθανεν αὐτῷ τὸ στρατ-

11 POINT

JOB FONT #7 50

Ἐπεὶ δὲ ἦσαν ἐν τῇ ἄνω χώρᾳ οἱ Ἑλληνας, ὅποια τῶν χωρίων τοῖς Δρίλαις ἀλώσιμα εἶναι ἐδόκει, ἐμπιπράντες ἀπήεσαν· καὶ οὐδὲν ἦν λαμβάνειν, εἰ μὴ ὕς ἢ βοῦς ἢ ἄλλο τι κτήνος τὸ πῦρ διαπεφευγός. Ἐν δ' ἦν χωρίον μητρόπολις αὐτῶν· εἰς τοῦτο πάντες συνερβύηκεσαν. Περὶ δὲ τοῦτο ἡ χαράδρα ἰσχυρῶς βαθεία, καὶ πρόσοδοι χαλεπία πρὸς τὸ χωρίον. Κοτυωρίτας δέ, οὓς ὑμετέρους φατ' εἰνανεῖε, τι αὐτῶν εἰλήφαμεν, αὐτοῖ

12 POINT

JOB FONT #7 50

Ἄλλὰ γὰρ οὐ τὰ μέλλοντα ἔσσεσθαι βούλομαι λέγειν, πραχθέντα ὑπὸ τούτων οὐ δυνάμενος εἰπεῖν· οὐδὲ γὰρ ἀπώλεσε. τιμώμενος δὲ καὶ τῶν μεγίστων ἀξιούμενος, αὐτὸς ἐπαγγειλάμενος σώσειν τὴν πόλιν αὐτὸς ἀπώλεσε, φάσκων τὴν πράγμα ἡύρηκέναι μέγα καὶ πολλοῦ ἄξιον. ὑπέχετο δὲ εἰρήνην ποιήσειν μήτε ὄμηρα δούς μήτε τὰ τεῖχη καθελὼν μήτε τὰς ναῦς παραδούς· ταῦτα δὲ εἰπεῖν

AMERICAN TYPE FOUNDERS COMPANY

## Heavyface Greek

Heavyface Greek cast to order in fonts of 50 lbs. and upwards

8 POINT

JOB FONT \$7 50

Οὐκοῦν οὐδ' ἂν εἰς ἀντίποι ὡς οὐ συμ-  
φέρει τῇ πόλει καὶ Λακεδαιμονίους ἀσ-  
θενεῖς εἶναι καὶ Θεβαλοὺς τούτουςι. Ἔστι  
τοῖνον ἔν τινι τοιοῦτω καιρῷ τὰ πράγ-  
ματα νῦν εἶ τι δεῖ τοῖς εἰρημένοις πολλὰ κί-  
σθαι πρὸς ὑμῖν λόγοις τεκμήρασθαι, ὥστε Θε-  
βαλοὺς μὲν Ὀρχομενοῦ καὶ Θεσπιῶν καὶ  
Πλαταιῶν οἰκισθεισῶν ἀσθενεῖς γενέσθαι,  
Λακεδαιμονίους δέ, εἰ ποιήσονται τὴν  
Ἀρκαδίαν ὑφ' ἑαυτοῖς καὶ Μεγάλην πόλιν

κτείνω, f. κτενῶ (§120, 1), a. ἔκτευνα (§121),  
pf. ἔκτανον (§109, 3) (ἀποκτείνω is gen-  
erally used), to kill.

Κητσίας, -ου, (ὁ), *Ctesias*, a Greek physi-  
cian at the Persian court.

Κύδνος, -ου, (ὁ), *Cydnius*, a river in Cilicia,  
flowing through the city of Tarsus.

κύκλος, -ου, (ὁ), a circle; κύκλω, in a circle.  
Eng. CYCLE.

κυκλώω, (ῶ), f. -ώσω, to encircle, surround.

11 POINT

JOB FONT \$7 50

Βοηθήσαντες δὲ ἐς αὐτὸ Πασιτελίδας τε ὁ Λακεδαιμόνιος ἄρχων  
καὶ ἡ παρούσα φυλακὴ προσβαλῆντων τῶν Ἀθηναίων ἠμύνοντο. καὶ  
ὡς ἐβιάζοντο καὶ αἱ νῆες ἅμα περιέπλεον ἐς τὸν λιμένα περιπεμφθεῖσθαι,  
δείσας ὁ Πασιτελίδας μὴ αἶτε νῆες φθάσωσι λαβοῦσαι ἐρήμον τὴν πόλιν  
καὶ τοῦ τειχίσματος ἀλισκομένου ἐγκαταληφθῆ, ἀπολιπὼν αὐτὸ δρόμῳ  
ἐχώρει ἐς τὴν πόλιν. οἱ δὲ Ἀθηναῖοι φθάνουσιν οἱ τε ἀπὸ τῶν νεῶν  
ἐλόντες τὴν Ἰσθμὸν καὶ ὁ πεζὸς ἐπισπόμενος αὐτοβοεῖ κατὰ τὸ

## Inscription Greek

10 POINT

30 A \$4 80

ΡΗΞΑΝΤΑΨΙΡΑΦΥΛΛΞΑΝΤΑ  
ΠΑΝΛΥΡΑΦΥΛΛΞΑΝΤΑ  
ΤΑΜΙΕΥΞΑΝΤΑΔΕΚΑΠΤΕΤΕΥΞΑΝΤΑ↓  
ΓΡΑΜΜΑΤΕΥΞΑΝΤΑΚΑΙΤΗΡΦΙΛΟΞΕΒΑΣΤΟΥ  
ΓΕΡΟΥΣΙΑΣΚΑΙΤΩΝΦΙΛΟΞΕΒΑΣΤΩΝ  
ΝΕΨΗΝΚΑΙΡΩΜΑΙΨΗΝΥΠΟΣΧΟΜΕΝΟΝ  
ΚΑΙΕΙΣΤΗΝΑΛΟΡΑΝΚΙΟΝΑΣΕΙΚΟΣΙ  
ΞΚΟΥΤΙΩΝΚΑΝΤΑΚΙΟΝΑΣΕΙΚΟΝΙ  
ΚΑΙΤΑΨΤΗΝΤΗΝΕΞΕΠΡΑΝΑΝΤΟΥΠΕΝΟΣ  
ΑΝΑΦΕΝΤΑΚΑΙΤΗΝΤΗΚΛΑΥΔΙΑΙΒΟΥΗ  
ΚΡΥΣΤΕΛΑΜΒΑΝΕΙΝΚΑΘΕΩ  
ΚΛΕΩΝΤΟΣΕΝΒΑΔΕΕΚΑΣΤΟΝΒΟΥ  
ΘΕΥΤΩΥΗΜΕΦΑΨΝΕΤΕΛΕΩΣ

AMERICAN TYPE FOUNDERS COMPANY

# GREEK

Smallest font, 15 lbs.

12 POINT

PER LB. \$1 16

Ἰδὼν δὲ τοὺς ὄχλους ἀνέβη εἰς τὸ ὄρος· καὶ καθίσαν-  
τος αὐτοῦ, προσήλθον αὐτῷ οἱ μαθηταὶ αὐτοῦ· καὶ  
ἀνοίξας τὸ στόμα αὐτοῦ, ἐδίδασκειν αὐτοὺς, λέγων·  
μακάριοι οἱ πτωχοὶ τῆ πνεύματι· ὅτι αὐτῶν ἐστὶν  
ἡ βασιλεία τῶν οὐρανῶν μακάριοι οἱ πενθοῦντες· ὅτι  
αὐτοὶ παρακληθήσονται μακάριοι οἱ πραεῖς· ὅτι  
αὐτοὶ κληρονομήσουσι τὴν γῆν μακάριοι οἱ πεινώντες

ΑΒΓΔΕΖΗΘΙΚΛΜΝΞΟΠΡΣΤΤΦΧΨΩ

Smallest font, 15 lbs.

10 POINT NO 2

PER LB. \$1 30

ΕΔΕΙ μὲν, ὦ ἄνδρες Ἀθηναῖοι, τοὺς λέγοντας ἅπαντας ἐν ὑμῖν  
μῆτε πρὸς ἔχθραν ποιέσθαι λόγον μηδένα, μῆτε πρὸς χάριν· ἀλλ' ὁ  
βέλτιστον ἕκαστος ἡγεῖτο, τοῦτ' ἀπιφαινεσθαι· ἄλλως τε καὶ περὶ κοινῶ,  
πραγμάτων καὶ μεγάλων ὑμῶν δουλευομένων· ἐπειδὴ δ' ἔνιοι, τὰ μὲν,  
φιλονεικίαι, τὰ δ' ἢ τινι δήποτ' αἰτία περιύγονται λέγειν ὑμᾶς, ὡ  
ἄνδρες Ἀθηναῖοι, τοὺς πολλοὺς δεῖ πάντα τ' ἀλλ' ἀφέντας, ἀ τῆ  
πόλει νομίζετε συμφέρον, τὰυτα καὶ ψηφίζεσθαι καὶ πράττειν· ἢ  
μὲν οὖν σπουδῇ περὶ τῶν ἐν Χερσονήσῳ πραγμάτων ἐσι καὶ τῆς  
στρατείας ἦν εὐδέκατον μί,να τουτονί, Φιλίππου ἐν Θράκῃ ποιεῖται.

Α Β Γ Δ Ε Ζ Η Θ Ι Κ Λ Μ Ν Ξ Ο Π Ρ Σ Τ Τ Φ Χ Ψ Ω

Smallest font, 15 lbs.

11 POINT

PER LB. \$1 22

ΕΔΕΙ μὲν, ὦ ἄνδρες Ἀθηναῖοι, τοὺς λέγοντας ἅπαντας ἐν  
ὑμῖν, μῆτε πρὸς ἔχθραν ποιέσθαι λόγον μηδένα, μῆτε πρὸς  
χάριν· ἀλλ' ὁ βέλτιστον ἕκαστος ἡγεῖτο τοῦτ' ἀπιφαινεσθαι·  
ἄλλως τε, καὶ περὶ κοινῶν πραγμάτων καὶ μεγάλων ὑμῶν  
δουλευομένων· ἐπειδὴ δ' ἔνιοι, τὰ μὲν, φιλονεικίαι, τὰ δ' ἢ  
τινι δήποτ' αἰτίῃ προύγονται λέγειν ὑμᾶς ὡ ἄνδρες Ἀθη-  
ναῖοι, τοὺς πολλοὺς δεῖ πάντα τ' ἀλλ' ἀφέντας, ἀ τῆ πόλει  
νομίζετε συμφέρον, τὰυτα καὶ ψηφίζεσθαι καὶ πράττειν.

ΑΒΓΔΕΖΗΘΙΚΛΜΝΞΟΠΡΣΤΤΥΤΥΦΧΨΩ

Smallest font, 15 lbs.

9 POINT NO 2

PER LB. \$1 44

Ἰδὼν δὲ τοὺς ὄχλους ἀνέβη εἰς τὸ ὄρος· καὶ καθίσαντος αὐτοῦ, προσήλθον  
αὐτῷ οἱ μαθηταὶ αὐτοῦ· καὶ ἀνοίξας τὸ στόμα αὐτοῦ, ἐδίδασκειν αὐτοὺς,  
λέγων· μακάριοι οἱ πτωχοὶ τῷ πνεύματι· ὅτι αὐτῶν ἐστὶν ἡ βασιλεία  
τῶν οὐρανῶν μακάριοι οἱ πενθοῦντες· ὅτι αὐτοὶ παρακληθήσονται μακάριοι  
οἱ πραεῖς· ὅτι αὐτοὶ κληρονομήσουσι τὴν γῆν μακάριοι οἱ πεινώντες καὶ  
διψῶντες τὴν δικαιοσύνην· ὅτι αὐτοὶ χορτασθήσονται μακάριοι οἱ ἐλεήμονες·  
ὅτι αὐτοὶ ἐλεηθήσονται μακάριοι οἱ καθαροὶ τῆ καρδίᾳ· ὅτι αὐτοὶ τὸν Θεὸν  
θεύονται μακάριοι οἱ εἰρηνοποιοί· ὅτι αὐτῶν υἱὸς Θεοῦ κληθήσονται μακάριοι  
οἱ δεδιωγμένοι ἕνεκεν δικαιοσύνης· ὅτι αὐτῶν ἐστὶν ἡ βασιλεία τῶν οὐρανῶν  
μακάριοι ἐστε, ὅταν δρεψίψωσαν ἕμας καὶ διώξωσι, καὶ εἰπωσι πᾶν πονηρὸν

Α Β Γ Δ Ε Ζ Η Θ Ι Κ Λ Μ Ν Ξ Ο Π Ρ Σ Τ Τ Υ Τ Υ Φ Χ Ψ Ω

Smallest font, 15 lbs.

8 POINT NO 2

PER LB. \$1 60

Ιδών δὲ τοὺς δόξλους ἀνέβη εἰς τὸ ὄρος· καὶ καθίσαντος αὐτοῦ, προσήλθον αὐτῷ οἱ μαθηταὶ αὐτοῦ· καὶ ἀνοίξας τὸ στόμα αὐτοῦ, εἰδάσκεν αὐτοὺς, λέγων· μακάριοι οἱ πενιῶντες τῶν οὐρανῶν μακάριοι οἱ πτωχοὶ τοῦ πνεύματος· ὅτι αὐτῶν ἐστὶν ἡ βασιλεία τῶν οὐρανῶν μακάριοι οἱ πρᾶεῖς· ὅτι αὐτοὶ κληρονομήσουσι τὴν γῆν· μακάριοι οἱ κληρονομήσαντες τὴν γῆν· μακάριοι οἱ πεινώντες καὶ διψῶντες τὴν δικαιοσύνην· ὅτι αὐτοὶ χορτασθήσονται μακάριοι οἱ ἐλεήμονες· ὅτι αὐτοὶ ἐλεηθήσονται μακάριοι οἱ καθαροὶ τῆ καρδίας· ὅτι αὐτοὶ τὸν Θεὸν ὄψονται μακάριοι οἱ εἰρηνοποιοί· ὅτι αὐτῶν υἱὸς Θεοῦ κληθήσονται μακάριοι οἱ δεδιωγμένοι ἕνεκεν δικαιοσύνης· ὅτι αὐτῶν ἐστὶν ἡ βασιλεία τῶν οὐρανῶν μακάριοι ἐστε, ὅταν ὀνειδίωσαν ὑμᾶς καὶ διώξωσι, καὶ εἴπωσι πᾶν πονηρὸν ῥῆμα καθ' ὑμῶν ψευδόμενοι, ἕνεκεν ἑμοῦ χαίρετε καὶ ἀγαλλιάσθε· ὅτι ὁ

Α Β Γ Δ Ε Ζ Η Θ Ι Κ Λ Μ Ν Ξ Ο Π Ρ Σ Τ Υ Φ Ψ Ω

Smallest font, 10 lbs.

6 POINT NO 2

PER LB. \$2 00

Ιδών δὲ τοὺς ὄξλους ἀνέβη εἰς τὸ ὄρος· καὶ καθίσαντος αὐτοῦ, προσήλθον αὐτῷ οἱ μαθηταὶ αὐτοῦ· καὶ ἀνοίξας τὸ στόμα αὐτοῦ, εἰδάσκεν αὐτοὺς, λέγων· μακάριοι οἱ πτωχοὶ τοῦ πνεύματος· ὅτι αὐτῶν ἐστὶν ἡ βασιλεία τῶν οὐρανῶν μακάριοι οἱ πεινώντες· ὅτι αὐτοὶ παρακληθήσονται μακάριοι οἱ πρᾶεῖς· ὅτι αὐτοὶ κληρονομήσουσι τὴν γῆν· μακάριοι οἱ πεινώντες καὶ διψῶντες τὴν δικαιοσύνην· ὅτι αὐτοὶ χορτασθήσονται μακάριοι οἱ ἐλεήμονες· ὅτι αὐτοὶ ἐλεηθήσονται μακάριοι οἱ καθαροὶ τῆ καρδίας· ὅτι αὐτοὶ τὸν Θεὸν ὄψονται μακάριοι οἱ εἰρηνοποιοί· ὅτι αὐτοὶ υἱοὶ Θεοῦ κληθήσονται μακάριοι οἱ δεδιωγμένοι ἕνεκεν δικαιοσύνης· ὅτι αὐτῶν ἐστὶν ἡ βασιλεία τῶν οὐρανῶν μακάριοι ἐστε, ὅταν ὀνειδίωσαν ὑμᾶς καὶ διώξωσι, καὶ εἴπωσι πᾶν πονηρὸν ῥῆμα καθ' ὑμῶν ψευδόμενοι, ἕνεκεν ἑμοῦ χαίρετε καὶ ἀγαλλιάσθε· ὅτι ὁ μισθὸς ὑμῶν πολὺς ἐν τοῖς οὐρανοῖς, ὅστω γὰρ εἰδώσαν τοὺς προφήτας τοὺς πρὸ ὑμῶν. Ὑμεῖς ἐστε τὸ ἅλας τῆς γῆς· ἐάν δὲ τὸ ἅλας μαρωθῇ, ἕν τίνι ἐλισθήσεται; εἰς οὐδὲν ἰσχύει ἐτι, εἰ μὴ βληθῆναι ἐξω, καὶ καταπετεῖσθαι ὑπὸ τοῦ ἀνθρώπου ὅστις ἐστε τὸ φῶς τοῦ κόσμου· οὐ δύναται πόλις κρυβῆναι ἐπάνω ὄρους

Α Β Γ Δ Ε Ζ Η Θ Ι Κ Λ Μ Ν Ξ Ο Π Ρ Σ Τ Υ Φ Ψ Ω

Smallest font, 10 lbs.

7 POINT NO 2

PER LB. \$1 80

Ιδών δὲ τοὺς ὄξλους ἀνέβη εἰς τὸ ὄρος· καὶ καθίσαντος αὐτοῦ, προσήλθον αὐτῷ οἱ μαθηταὶ αὐτοῦ· καὶ ἀνοίξας τὸ στόμα αὐτοῦ, εἰδάσκεν αὐτοὺς, λέγων· μακάριοι οἱ πτωχοὶ τοῦ πνεύματος· ὅτι αὐτῶν ἐστὶν ἡ βασιλεία τῶν οὐρανῶν μακάριοι οἱ πεινώντες· ὅτι αὐτοὶ παρακληθήσονται μακάριοι οἱ πρᾶεῖς· ὅτι αὐτοὶ κληρονομήσουσι τὴν γῆν· μακάριοι οἱ πεινώντες καὶ διψῶντες τὴν δικαιοσύνην· ὅτι αὐτοὶ χορτασθήσονται μακάριοι οἱ ἐλεήμονες· ὅτι αὐτοὶ ἐλεηθήσονται μακάριοι οἱ καθαροὶ τῆ καρδίας· ὅτι αὐτοὶ τὸν Θεὸν ὄψονται μακάριοι οἱ εἰρηνοποιοί· ὅτι αὐτοὶ υἱοὶ Θεοῦ κληθήσονται μακάριοι οἱ δεδιωγμένοι ἕνεκεν δικαιοσύνης· ὅτι αὐτῶν ἐστὶν ἡ βασιλεία τῶν οὐρανῶν μακάριοι ἐστε, ὅταν ὀνειδίωσαν ὑμᾶς καὶ διώξωσι, καὶ εἴπωσι πᾶν πονηρὸν ῥῆμα καθ' ὑμῶν ψευδόμενοι, ἕνεκεν ἑμοῦ χαίρετε καὶ ἀγαλλιάσθε· ὅτι ὁ μισθὸς ὑμῶν πολὺς ἐν τοῖς οὐρανοῖς, ὅστω γὰρ εἰδώσαν τοὺς προφήτας τοὺς πρὸ ὑμῶν. Ὑμεῖς ἐστε τὸ ἅλας τῆς γῆς· ἐάν δὲ τὸ ἅλας μαρωθῇ, ἕν τίνι ἐλισθήσεται; εἰς οὐδὲν ἰσχύει ἐτι, εἰ μὴ βληθῆναι ἐξω

Α Β Γ Δ Ε Ζ Η Θ Ι Κ Λ Μ Ν Ξ Ο Π Ρ Σ Τ Υ Φ Ψ Ω

Smallest font, 10 lbs.

4½ POINT

PER LB. \$3 20

Ιδών δὲ τοὺς ὄξλους ἀνέβη εἰς τὸ ὄρος· καὶ καθίσαντος αὐτοῦ, προσήλθον αὐτῷ οἱ μαθηταὶ αὐτοῦ· καὶ ἀνοίξας τὸ στόμα αὐτοῦ, εἰδάσκεν αὐτοὺς, λέγων· μακάριοι οἱ πτωχοὶ τοῦ πνεύματος· ὅτι αὐτῶν ἐστὶν ἡ βασιλεία τῶν οὐρανῶν μακάριοι οἱ πεινώντες· ὅτι αὐτοὶ παρακληθήσονται μακάριοι οἱ πρᾶεῖς· ὅτι αὐτοὶ κληρονομήσουσι τὴν γῆν· μακάριοι οἱ πεινώντες καὶ διψῶντες τὴν δικαιοσύνην· ὅτι αὐτοὶ χορτασθήσονται μακάριοι οἱ ἐλεήμονες· ὅτι αὐτοὶ υἱοὶ Θεοῦ κληθήσονται μακάριοι οἱ καθαροὶ τῆ καρδίας· ὅτι αὐτοὶ τὸν Θεὸν ὄψονται μακάριοι οἱ εἰρηνοποιοί· ὅτι αὐτοὶ υἱοὶ Θεοῦ κληθήσονται μακάριοι οἱ δεδιωγμένοι ἕνεκεν δικαιοσύνης· ὅτι αὐτῶν ἐστὶν ἡ βασιλεία τῶν οὐρανῶν μακάριοι ἐστε, ὅταν ὀνειδίωσαν ὑμᾶς καὶ διώξωσι, καὶ εἴπωσι πᾶν πονηρὸν ῥῆμα καθ' ὑμῶν ψευδόμενοι, ἕνεκεν ἑμοῦ χαίρετε καὶ ἀγαλλιάσθε· ὅτι ὁ μισθὸς ὑμῶν πολὺς ἐν τοῖς οὐρανοῖς, ὅστω γὰρ εἰδώσαν τοὺς προφήτας τοὺς πρὸ ὑμῶν. Ὑμεῖς ἐστε τὸ ἅλας τῆς γῆς· ἐάν δὲ τὸ ἅλας μαρωθῇ, ἕν τίνι ἐλισθήσεται; εἰς οὐδὲν ἰσχύει ἐτι, εἰ μὴ βληθῆναι ἐξω, καὶ καταπετεῖσθαι ὑπὸ τοῦ ἀνθρώπου ὅστις ἐστε τὸ φῶς τοῦ κόσμου· οὐ δύναται πόλις κρυβῆναι ἐπάνω ὄρους ὅσταν ὀνειδίωσαν ὑμᾶς καὶ διώξωσι, καὶ εἴπωσι πᾶν πονηρὸν ῥῆμα καθ' ὑμῶν ψευδόμενοι, ἕνεκεν ἑμοῦ χαίρετε καὶ ἀγαλλιάσθε· ὅτι ὁ μισθὸς ὑμῶν πολὺς ἐν τοῖς οὐρανοῖς, ὅστω γὰρ εἰδώσαν τοὺς προφήτας τοὺς πρὸ ὑμῶν. Ὑμεῖς ἐστε τὸ ἅλας τῆς γῆς· ἐάν δὲ τὸ ἅλας μαρωθῇ, ἕν τίνι ἐλισθήσεται; εἰς οὐδὲν ἰσχύει ἐτι, εἰ μὴ βληθῆναι ἐξω, καὶ καταπετεῖσθαι ὑπὸ τοῦ ἀνθρώπου ὅστις ἐστε τὸ φῶς τοῦ κόσμου· οὐ δύναται πόλις κρυβῆναι ἐπάνω ὄρους

Α Β Γ Δ Ε Ζ Η Θ Ι Κ Λ Μ Ν Ξ Ο Π Ρ Σ Τ Υ Φ Ψ Ω



# Hebrew No 1

10 POINT

JOB FONT \$3 80

דְּבַרֵי קִהְלֵת בְּיַדְדוֹר מְלֶךְ בִּירוּשָׁלַם: הַבֵּל הַבְּלִים אָמַר קִהְלֵת  
הַבֵּל הַבְּלִים הַבֵּל הַבֵּל: מַה־יִתְרוֹן לְאָדָם בְּכָל־עֲמָלוֹ שְׂיַעֲמַל  
תַּחַת הַשָּׁמֶשׁ: דוֹר הַלֶּךְ וְדוֹר בָּא וְהָאָרֶץ לְעוֹלָם עִמְדַת: וּזְרַח  
הַשָּׁמֶשׁ וּבָא הַשָּׁמֶשׁ וְאֵל־מְקוֹמוֹ שׁוֹאֵף זֹרַח הוּא שֵׁם: הוֹלֵךְ  
אֶל־דְּרוֹם וְסוֹבֵב אֶל־צָפוֹן סוֹבֵב וְסוֹבֵב הַרוּחַ וְעַל־סִבִּיבֹתָיו

9 POINT

JOB FONT \$3 80

דְּבַרֵי קִהְלֵת בְּיַדְדוֹר מְלֶךְ בִּירוּשָׁלַם: הַבֵּל הַבְּלִים אָמַר קִהְלֵת הַבֵּל הַבְּלִים הַבֵּל הַבֵּל:  
מַה־יִתְרוֹן לְאָדָם בְּכָל־עֲמָלוֹ שְׂיַעֲמַל תַּחַת הַשָּׁמֶשׁ: דוֹר הַלֶּךְ וְדוֹר בָּא וְהָאָרֶץ  
לְעוֹלָם עִמְדַת: וּזְרַח הַשָּׁמֶשׁ וּבָא הַשָּׁמֶשׁ וְאֵל־מְקוֹמוֹ שׁוֹאֵף זֹרַח הוּא שֵׁם: הוֹלֵךְ  
אֶל־דְּרוֹם וְסוֹבֵב אֶל־צָפוֹן סוֹבֵב וְסוֹבֵב הַרוּחַ וְעַל־סִבִּיבֹתָיו שֵׁב הַרוּחַ: כֹּל־  
הַנַּחֲלִים הַלְכִים אֱלֹהִים וְהִים אֵינְנו מְלֵא אֶל־מְקוֹם שֶׁהַנַּחֲלִים הַלְכִים שֵׁם הֵם שְׁבוּם  
לִלְכַת: כֹּל־הַדְּבָרִים יַגִּיעִים לֹא־יִוֹכַל אִישׁ לְדַבֵּר לֹא־תִשְׁבַּא עֵין לְרֹאוֹת וְלֹא־תִמְלֵא

6 POINT

JOB FONT \$3 80

דְּבַרֵי קִהְלֵת בְּיַדְדוֹר מְלֶךְ בִּירוּשָׁלַם: הַבֵּל הַבְּלִים אָמַר קִהְלֵת הַבֵּל הַבְּלִים הַבֵּל הַבֵּל: מַה־יִתְרוֹן  
לְאָדָם בְּכָל־עֲמָלוֹ שְׂיַעֲמַל תַּחַת הַשָּׁמֶשׁ: דוֹר הַלֶּךְ וְדוֹר בָּא וְהָאָרֶץ לְעוֹלָם עִמְדַת: וּזְרַח הַשָּׁמֶשׁ  
וּבָא הַשָּׁמֶשׁ וְאֵל־מְקוֹמוֹ שׁוֹאֵף זֹרַח הוּא שֵׁם: הוֹלֵךְ אֶל־דְּרוֹם וְסוֹבֵב אֶל־צָפוֹן סוֹבֵב וְסוֹבֵב הַרוּחַ  
וְעַל־סִבִּיבֹתָיו שֵׁב הַרוּחַ: כֹּל־הַנַּחֲלִים הַלְכִים אֱלֹהִים וְהִים אֵינְנו מְלֵא אֶל־מְקוֹם שֶׁהַנַּחֲלִים  
הַלְכִים שֵׁם הֵם שְׁבוּם לִלְכַת: כֹּל־הַדְּבָרִים יַגִּיעִים לֹא־יִוֹכַל אִישׁ לְדַבֵּר לֹא־תִשְׁבַּע עֵין לְרֹאוֹת וְלֹא־  
תִּמְלֵא אֶן מִשְׁמַע: מַה־שֶּׁהִיָּה הוּא שִׁיְהִיָּה וּמַה־שֶּׁנַּעֲשֶׂה הוּא שִׁיעֲשֶׂה וְאֵין כֹּל־חֵדֶשׁ תַּחַת הַשָּׁמֶשׁ

*This size supplied with or without accented letters, as required*

6 POINT

JOB FONT \$3 80

דְּבַרֵי קִהְלֵת בְּיַדְדוֹר מְלֶךְ בִּירוּשָׁלַם: הַבֵּל הַבְּלִים אָמַר קִהְלֵת הַבֵּל הַבְּלִים הַבֵּל הַבֵּל: מַה־יִתְרוֹן  
לְאָדָם בְּכָל־עֲמָלוֹ שְׂיַעֲמַל תַּחַת הַשָּׁמֶשׁ: דוֹר הַלֶּךְ וְדוֹר בָּא וְהָאָרֶץ לְעוֹלָם עִמְדַת: וּזְרַח הַשָּׁמֶשׁ וּבָא  
הַשָּׁמֶשׁ וְאֵל־מְקוֹמוֹ שׁוֹאֵף זֹרַח הוּא שֵׁם: הוֹלֵךְ אֶל־דְּרוֹם וְסוֹבֵב אֶל־צָפוֹן סוֹבֵב וְסוֹבֵב הַרוּחַ וְעַל־  
סִבִּיבֹתָיו שֵׁב הַרוּחַ: כֹּל־הַנַּחֲלִים הַלְכִים אֱלֹהִים וְהִים אֵינְנו מְלֵא אֶל־מְקוֹם שֶׁהַנַּחֲלִים הַלְכִים  
שֵׁם הֵם שְׁבוּם לִלְכַת: כֹּל־הַדְּבָרִים יַגִּיעִים לֹא־יִוֹכַל אִישׁ לְדַבֵּר לֹא־תִשְׁבַּע עֵין לְרֹאוֹת וְלֹא־תִמְלֵא  
אֶן מִשְׁמַע: מַה־שֶּׁהִיָּה הוּא שִׁיְהִיָּה וּמַה־שֶּׁנַּעֲשֶׂה הוּא שִׁיאֲשֶׁר־וּ אִוִי בַעֲרֵנָהאֲרֵךְ הַעֵסֶסעֶלְכַעֲרַג

*Vowel accents not supplied unless specially ordered. With the exception of 8 Point, this series is suitable only for classical work*

AMERICAN TYPE FOUNDERS COMPANY

## Hebrew No 2

24 POINT

JOB FONT #3 00

אין דער ערסטען צייט דעם בוכדרוקעס  
ווארען דיא בוכדרוקער זעהר אפט אויך  
אלס שריפטגייעססער אונד בוכהענדלער

18 POINT

JOB FONT #2 50

אין דער ערסטען צייט דעם בוכדרוקעס ווארען  
דיא בוכדרוקער צוגלייך שריפטגייעססער אונד  
ניכט זעלטען אויך געלעהרטע. ערסט נאכדעם

12 POINT

JOB FONT #2 50

אין דער ערסטען צייט דעם בוכדרוקעס ווארען דיא בוכדרוקער צוגלייך  
שריפטגייעססער, בוכהענדלער אונד ניכט זעלטען אויך געלעהרטע. ערסט  
אללמעהליג בילדעטען זיך דיא בוכדרוקעריי אונד דיא שריפטגייעססעריי אלס  
זעלבסטשטענדיגע געווערבע אויס, דאגעגען פינדעט זיך פערלענגער אונד

10 POINT

JOB FONT #2 25

אין דער ערסטען צייט דעם בוכדרוקעס ווארען דרוקער צוגלייך שריפטגייעססער,  
בוכהענדלער אונד ניכט זעלטען אויך געלעהרטע. ערסט אללמעהליג בילדעטען  
זיך דיא בוכדרוקעריי אונד דיא שריפטגייעססעריי אלס זעלבסטשטענדיגע  
געווערבע אויס, דאגעגען פינדעט זיך פערלענגער אונד דרוקער נאך יעצט הייפיג

8 POINT

JOB FONT #2 25

אין דער ערסטען צייט דעם בוכדרוקעס ווארען דיא בוכדרוקער צוגלייך שריפטגייעססער, בוכהענדלער אונד  
ניכט זעלטען אויך געלעהרטע. ערסט אללמעהליג בילדעטען זיך דיא בוכדרוקעריי אונד דיא שריפטגייעססעריי  
אלס זעלבסטשטענדיגע געווערבע אויס, דאגעגען פינדעט זיך פערלענגער אונד דרוקער נאך יעצט הייפיג  
אין איינער פערזאן פערזאן פערזאן. דאס בוכדרוקערייגעווערבע טראט פון פארן הערין אלס איינע קונסט אויף  
אונד ווארדע אלס זאלכע פון רען געבילדעטען אונד העהרען שטענדען געאיבט בערנהארד העסעלבערג

*This series is commonly used for newspapers. Not intended to be used with accents*

AMERICAN TYPE FOUNDERS COMPANY



## Rabbinic

12 POINT

PER FONT \$11 80  
Font weighs 10 lbs.

מזיומתי קורין את שמע צערצית. ונעשה שהכהנים ככנסים לאכול בתרומתן. עד סוף  
האשמורה הראשונה דצרי ר' אליאזר. וחכמים אומרים עד חלות. ר"ג אומר עד שיעלה  
עמוד השחר. ונעשה שצאו צניו ונצית המשתה אומר לו לא קרינו את שמע. אומר להם

10 POINT

PER FONT \$10 40  
Font weighs 8 lbs.

לך לך מארנך וממולדתך ומנצית אביך אל  
הארץ אשר ארצך לתת אותה לך ולצניך כי  
שם צאריך היתה ארצך ושם אעשך לגוי גדול  
ואגדלה שוך ונצרכו נך כל ונשפחות האדמה

8 POINT

PER FONT \$12 80  
Font weighs 8 lbs.

בעל כתר כהונה ערך חלק אומר בנמרה מ"ק י"ג אע"פ  
קריה ליה חילוקם כו. הודעתין שבגלי הנמרה נסתפקו  
בש' המלות אשר זכרום חכמי המשנה וקצרה יד שכלם  
ואין ידם משנת ומאין הבין הוציאו המלה משמעותה אור  
כל המלות הנרות שצאו על יד בערנהארד העם לנצברג

## Russian No 10

12 POINT

PER LB. \$1 18  
Smallest font, 25 lbs.

Общество Американскихъ Словолитниковъ рекомендуетъ  
свой богатый складъ Англійскихъ, Нѣмецкихъ, Грѣче-  
скихъ и Еврейскихъ шрифтовъ, сдѣланныхъ изъ самаго  
лучшаго матеріала. Печатныя и бумаго-рѣзные машины  
наилучшей конструкціи и всякіе типографическіе мате-  
ріалы по самымъ дешевымъ цѣнамъ Борисъ Гессельбергъ

## Armenian

14 POINT

PER LB. \$1 12  
Smallest font, 25 lbs.

Վաղաքական կացութիւնն ի Հայաստան յոյժ  
ծանր է և ճգնաժամական: Հայկական Խնդիրն  
որ ի բազմաց հետէ զաղբած էր զԵւրոպա գրգռելէ

10 POINT

PER LB. \$1 30  
Smallest font, 25 lbs.

կացութիւնն ի Հայաստան յոյժ ծանր է և ճգնաժամական: Հայկական  
Խնդիրն որ ի բազմաց հետէ զաղբած էր զԵւրոպա գրգռելէ, արդէն  
անցած է նախնական աստիճաններն և այսօր առարկայն է որոշման  
և խորհրդեան Մեծ Պետութեանց: Հայ Լիաստն այսօր կը կանգնի

## Superior and Inferior Letters

Prices quoted are per font of either

12 POINT	PER FONT \$3 20
abcdefghijklmnopqrstuvw	abcdefghijklmnopqrstuvw
11 POINT	PER FONT \$3 00
abcdefghijklmnopqrstuvw	abcdefghijklmnopqrstuvw
10 POINT	PER FONT \$2 95
abcdefghijklmnopqrstvwxyz	abcdefghijklmnopqrstvwxyz
9 POINT	PER FONT \$2 90
abcdefghijklmnopqrstvwxyz	abcdefghijklmnopqrstvwxyz
6 POINT	PER FONT \$2 90
abcdefghijklmnopqrstvwxyz	abcdefghijklmnopqrstvwxyz
7 POINT	PER FONT \$3 15
abcdefghijklmnopqrstvwxyz	abcdefghijklmnopqrstvwxyz
6 POINT	PER FONT \$2 75
abcdefghijklmnopqrstvwxyz	abcdefghijklmnopqrstvwxyz
5½ POINT	PER FONT \$3 00
abcdefghijklmnopqrstvwxyz	abcdefghijklmnopqrstvwxyz

## Piece Fractions

12 POINT	PER FONT \$3 00
1 2 3 4 5 6 7 8 9 0	1 2 3 4 5 6 7 8 9 0
$\frac{2}{5}$ $\frac{3}{16}$ $\frac{5}{36}$ $\frac{13}{68}$ $\frac{9}{100}$ $\frac{33}{1000}$	
11 POINT	PER FONT \$3 30
1 2 3 4 5 6 7 8 9 0	1 2 3 4 5 6 7 8 9 0
$\frac{2}{3}$ $\frac{3}{7}$ $\frac{5}{9}$ $\frac{4}{25}$ $\frac{35}{86}$ $\frac{7}{230}$ $\frac{68}{2450}$	
10 POINT	PER FONT \$3 50
1 2 3 4 5 6 7 8 9 0	1 2 3 4 5 6 7 8 9 0
$\frac{2}{5}$ $\frac{3}{16}$ $\frac{4}{27}$ $\frac{13}{68}$ $\frac{9}{100}$ $\frac{12}{160}$ $\frac{33}{1000}$	
9 POINT	PER FONT \$3 60
1 2 3 4 5 6 7 8 9 0	1 2 3 4 5 6 7 8 9 0
$\frac{1}{8}$ $\frac{2}{5}$ $\frac{4}{27}$ $\frac{5}{36}$ $\frac{13}{68}$ $\frac{12}{160}$ $\frac{17}{380}$ $\frac{33}{1000}$	
8 POINT	PER FONT \$3 60
1 2 3 4 5 6 7 8 9 0	1 2 3 4 5 6 7 8 9 0
$\frac{1}{4}$ $\frac{2}{5}$ $\frac{3}{17}$ $\frac{5}{37}$ $\frac{6}{45}$ $\frac{23}{58}$ $\frac{9}{150}$ $\frac{31}{497}$ $\frac{97}{1500}$	
7 POINT	PER FONT \$5 00
1 2 3 4 5 6 7 8 9 0	1 2 3 4 5 6 7 8 9 0
$\frac{1}{2}$ $\frac{2}{5}$ $\frac{3}{7}$ $\frac{4}{26}$ $\frac{37}{45}$ $\frac{4}{74}$ $\frac{23}{245}$ $\frac{287}{2658}$	
6 POINT	PER FONT \$5 00
1 2 3 4 5 6 7 8 9 0	1 2 3 4 5 6 7 8 9 0
$\frac{2}{3}$ $\frac{3}{7}$ $\frac{4}{16}$ $\frac{4}{38}$ $\frac{4}{45}$ $\frac{23}{100}$ $\frac{16}{160}$ $\frac{33}{230}$ $\frac{188}{1000}$	

## Superior and Inferior Figures

Prices quoted are per font of either

12 POINT	PER FONT \$1 65
1 2 3 4 5 6 7 8 9 0	1 2 3 4 5 6 7 8 9 0
11 POINT	PER FONT \$1 50
1 2 3 4 5 6 7 8 9 0	1 2 3 4 5 6 7 8 9 0
10 POINT	PER FONT \$1 55
1 2 3 4 6 6 7 8 9 0	1 2 3 4 5 6 7 8 9 0
9 POINT	PER FONT \$1 45
1 2 3 4 5 6 7 8 9 0	1 2 3 4 5 6 7 8 9 0
8 POINT	PER FONT \$1 50
1 2 3 4 6 6 8 9 0	1 2 3 4 5 6 7 8 9 0
7 POINT	PER FONT \$1 60
1 2 3 4 6 6 7 8 9 0	1 2 3 4 5 6 7 8 9 0
6 POINT	PER FONT \$1 35
1 2 3 4 5 6 7 8 9 0	1 2 3 4 5 6 7 8 9 0
5½ POINT	PER FONT \$1 50
1 2 3 4 5 6 7 8 9 0	1 2 3 4 5 6 7 8 9 0

## Special Fractions

10 POINT EM FRACTIONS	1 LB. FONT 74 CTS.
$\frac{1}{4}$ $\frac{1}{2}$ $\frac{3}{4}$ $\frac{1}{8}$ $\frac{3}{8}$ $\frac{5}{8}$ $\frac{7}{8}$ $\frac{1}{3}$ $\frac{2}{3}$	
9 POINT EM FRACTIONS	1 LB. FONT 80 CTS.
$\frac{1}{4}$ $\frac{1}{2}$ $\frac{3}{4}$ $\frac{1}{8}$ $\frac{3}{8}$ $\frac{5}{8}$ $\frac{7}{8}$ $\frac{1}{3}$ $\frac{2}{3}$	
6 POINT EM FRACTIONS	1 LB. FONT 90 CTS.
$\frac{1}{4}$ $\frac{1}{2}$ $\frac{3}{4}$ $\frac{1}{8}$ $\frac{3}{8}$ $\frac{5}{8}$ $\frac{7}{8}$ $\frac{1}{3}$ $\frac{2}{3}$	
7 POINT EM FRACTIONS	1 LB. FONT \$1 00
$\frac{1}{4}$ $\frac{1}{2}$ $\frac{3}{4}$ $\frac{1}{8}$ $\frac{3}{8}$ $\frac{5}{8}$ $\frac{7}{8}$ $\frac{1}{3}$ $\frac{2}{3}$	
6 POINT EM FRACTIONS	1 LB. FONT \$1 16
$\frac{1}{4}$ $\frac{1}{2}$ $\frac{3}{4}$ $\frac{1}{8}$ $\frac{3}{8}$ $\frac{5}{8}$ $\frac{7}{8}$ $\frac{1}{3}$ $\frac{2}{3}$	
5½ POINT ONE-AND-A-HALF EM FRACTIONS	1 LB. FONT \$1 44
$\frac{1}{16}$ $\frac{3}{16}$ $\frac{5}{16}$ $\frac{7}{16}$ $\frac{9}{16}$ $\frac{11}{16}$ $\frac{13}{16}$ $\frac{15}{16}$	
5¼ POINT EM FRACTIONS	1 LB. FONT \$1 44
$\frac{1}{4}$ $\frac{1}{2}$ $\frac{3}{4}$ $\frac{1}{8}$ $\frac{3}{8}$ $\frac{5}{8}$ $\frac{7}{8}$ $\frac{1}{3}$ $\frac{2}{3}$	

AMERICAN TYPE FOUNDERS COMPANY

# Self Spacing Piece Fractions

PRICE \$2 50 PER POINT EACH SIZE

*These fonts are supplied with spaces, and can be used  
with ordinary as well as with Self Spacing Type*

12 POINT OLD STYLE NO 28

1211<sup>1</sup>/<sub>32</sub> 1234567890 1234567890 ~~1234567890~~ 1234567890 49<sup>5</sup>/<sub>16</sub>

11 POINT OLD STYLE NO 25

241<sup>7</sup>/<sub>32</sub> 1234567890 1234567890 ~~1234567890~~ 3<sup>7</sup>/<sub>7</sub> 4<sup>5</sup>/<sub>5</sub> 1234567890 1234567890 18<sup>7</sup>/<sub>16</sub>

10 POINT OLD STYLE NO 24

9019<sup>3</sup>/<sub>32</sub> 1234567890 1234567890 ~~1234567890~~ 5<sup>1</sup>/<sub>10</sub> 1<sup>3</sup>/<sub>3</sub> 1234567890 1234567890 94<sup>5</sup>/<sub>16</sub>

9 POINT OLD STYLE NO 28

7318<sup>3</sup>/<sub>32</sub> 1234567890 1234567890 ~~1234567890~~ 1<sup>5</sup>/<sub>5</sub> 2<sup>5</sup>/<sub>5</sub> 3<sup>6</sup>/<sub>6</sub> 4<sup>9</sup>/<sub>9</sub> 3<sup>1</sup>/<sub>10</sub> 1234567890 1234567890 25<sup>7</sup>/<sub>16</sub>

8 POINT OLD STYLE NO 22

241<sup>2</sup>/<sub>32</sub> 1234567890 1234567890 ~~1234567890~~ 1<sup>4</sup>/<sub>4</sub> 1<sup>2</sup>/<sub>2</sub> 2<sup>3</sup>/<sub>3</sub> 4<sup>5</sup>/<sub>5</sub> 5<sup>8</sup>/<sub>8</sub> 7<sup>8</sup>/<sub>8</sub> 8<sup>9</sup>/<sub>9</sub> 7<sup>2</sup>/<sub>20</sub> 1234567890 1234567890 56<sup>7</sup>/<sub>16</sub>

6 POINT OLD STYLE NO 27

4211<sup>3</sup>/<sub>32</sub> 1234567890 1234567890 ~~1234567890~~ 1<sup>3</sup>/<sub>3</sub> 2<sup>3</sup>/<sub>3</sub> 1<sup>4</sup>/<sub>4</sub> 1<sup>2</sup>/<sub>2</sub> 3<sup>4</sup>/<sub>4</sub> 1<sup>8</sup>/<sub>8</sub> 3<sup>8</sup>/<sub>8</sub> 5<sup>8</sup>/<sub>8</sub> 7<sup>8</sup>/<sub>8</sub> 3<sup>6</sup>/<sub>6</sub> 5<sup>6</sup>/<sub>6</sub> 1234567890 1234567890 33<sup>1</sup>/<sub>16</sub>

6 POINT ROMAN NO 20<sup>1</sup>/<sub>2</sub>

202<sup>7</sup>/<sub>32</sub> 1234567890 1234567890 ~~1234567890~~ 1<sup>3</sup>/<sub>3</sub> 2<sup>3</sup>/<sub>3</sub> 1<sup>4</sup>/<sub>4</sub> 3<sup>4</sup>/<sub>4</sub> 3<sup>5</sup>/<sub>5</sub> 5<sup>6</sup>/<sub>6</sub> 6<sup>7</sup>/<sub>7</sub> 7<sup>8</sup>/<sub>8</sub> 8<sup>9</sup>/<sub>9</sub> 10<sup>10</sup>/<sub>10</sub> 10<sup>11</sup>/<sub>11</sub> 13<sup>30</sup>/<sub>17</sub> 36 1234567890 1234567890 40<sup>1</sup>/<sub>16</sub>

7 POINT ROMAN NO 23<sup>1</sup>/<sub>2</sub>

3915<sup>1</sup>/<sub>16</sub> 1234567890 1234567890 ~~1234567890~~ 1<sup>3</sup>/<sub>3</sub> 2<sup>3</sup>/<sub>3</sub> 3<sup>5</sup>/<sub>5</sub> 6<sup>6</sup>/<sub>6</sub> 7<sup>7</sup>/<sub>7</sub> 8<sup>9</sup>/<sub>9</sub> 9<sup>10</sup>/<sub>10</sub> 10<sup>11</sup>/<sub>11</sub> 11<sup>12</sup>/<sub>12</sub> 1234567890 1234567890 57<sup>1</sup>/<sub>16</sub>

8 POINT ROMAN NO 18<sup>1</sup>/<sub>2</sub>

1911<sup>1</sup>/<sub>32</sub> 1234567890 1234567890 ~~1234567890~~ 1<sup>8</sup>/<sub>8</sub> 3<sup>5</sup>/<sub>5</sub> 5<sup>6</sup>/<sub>6</sub> 6<sup>7</sup>/<sub>7</sub> 7<sup>10</sup>/<sub>10</sub> 9<sup>50</sup>/<sub>19</sub> 20 1234567890 1234567890 84<sup>5</sup>/<sub>16</sub>

9 POINT ROMAN NO 32<sup>1</sup>/<sub>2</sub>

3212<sup>1</sup>/<sub>32</sub> 1234567890 1234567890 ~~1234567890~~ 2<sup>3</sup>/<sub>3</sub> 4<sup>5</sup>/<sub>5</sub> 5<sup>6</sup>/<sub>6</sub> 7<sup>8</sup>/<sub>8</sub> 9<sup>10</sup>/<sub>10</sub> 1234567890 1234567890 23<sup>9</sup>/<sub>16</sub>

10 POINT ROMAN NO 17<sup>1</sup>/<sub>2</sub>

7213<sup>1</sup>/<sub>32</sub> 1234567890 1234567890 ~~1234567890~~ 2<sup>9</sup>/<sub>9</sub> 4<sup>5</sup>/<sub>5</sub> 1234567890 1234567890 36<sup>7</sup>/<sub>16</sub>

11 POINT ROMAN NO 21<sup>1</sup>/<sub>2</sub>

4517<sup>1</sup>/<sub>32</sub> 1234567890 1234567890 ~~1234567890~~ 1234567890 21<sup>8</sup>/<sub>16</sub>

12 POINT ROMAN NO 31<sup>1</sup>/<sub>2</sub>

6020<sup>1</sup>/<sub>32</sub> 1234567890 1234567890 ~~1234567890~~ 1234567890 14<sup>9</sup>/<sub>16</sub>

AMERICAN TYPE FOUNDERS COMPANY

## De Vinne Fractions

24 POINT PER FONT 50 CTS.

$\frac{1}{4}$   $\frac{1}{2}$   $\frac{3}{4}$   $\frac{1}{3}$   $\frac{2}{3}$   
 $\frac{1}{8}$   $\frac{3}{8}$   $\frac{5}{8}$   $\frac{7}{8}$   
 % ¢

18 POINT PER FONT 50 CTS.

$\frac{1}{4}$   $\frac{1}{2}$   $\frac{3}{4}$   $\frac{1}{3}$   $\frac{2}{3}$   
 $\frac{1}{8}$   $\frac{3}{8}$   $\frac{5}{8}$   $\frac{7}{8}$   
 ¢ %

14 POINT PER FONT 50 CTS.

$\frac{1}{4}$   $\frac{1}{2}$   $\frac{3}{4}$   $\frac{1}{3}$   $\frac{2}{3}$   $\frac{1}{8}$   $\frac{3}{8}$   
 $\frac{5}{8}$   $\frac{7}{8}$

12 POINT PER FONT 50 CTS.

$\frac{1}{4}$   $\frac{1}{2}$   $\frac{3}{4}$   $\frac{1}{3}$   $\frac{2}{3}$   $\frac{1}{8}$   $\frac{3}{8}$   
 $\frac{5}{8}$   $\frac{7}{8}$  ¢ %

10 POINT PER FONT 50 CTS.

$\frac{1}{4}$   $\frac{1}{2}$   $\frac{3}{4}$   $\frac{1}{3}$   $\frac{2}{3}$   $\frac{1}{8}$   $\frac{3}{8}$   $\frac{5}{8}$   $\frac{7}{8}$  ¢ %

8 POINT PER FONT 50 CTS.

$\frac{1}{4}$   $\frac{1}{2}$   $\frac{3}{4}$   $\frac{1}{3}$   $\frac{2}{3}$   $\frac{1}{8}$   $\frac{3}{8}$   $\frac{5}{8}$   $\frac{7}{8}$  ¢ %

7 POINT PER FONT 50 CTS.

$\frac{1}{4}$   $\frac{1}{2}$   $\frac{3}{4}$   $\frac{1}{3}$   $\frac{2}{3}$   $\frac{1}{8}$   $\frac{3}{8}$   $\frac{5}{8}$   $\frac{7}{8}$  ¢ %

6 POINT PER FONT 50 CTS.

$\frac{1}{4}$   $\frac{1}{2}$   $\frac{3}{4}$   $\frac{1}{3}$   $\frac{2}{3}$   $\frac{1}{8}$   $\frac{3}{8}$   $\frac{5}{8}$   $\frac{7}{8}$  ¢ %

## De Vinne Condensed Fractions

36 POINT PER FONT 75 CTS.

$\frac{1}{4}$   $\frac{1}{2}$   $\frac{3}{4}$   $\frac{1}{3}$   $\frac{2}{3}$   
 $\frac{1}{8}$   $\frac{3}{8}$   $\frac{5}{8}$   $\frac{7}{8}$

30 POINT PER FONT 75 CTS.

$\frac{1}{4}$   $\frac{1}{2}$   $\frac{3}{4}$   $\frac{1}{3}$   $\frac{2}{3}$   $\frac{1}{8}$   $\frac{3}{8}$   $\frac{5}{8}$   $\frac{7}{8}$

24 POINT PER FONT 50 CTS.

$\frac{1}{4}$   $\frac{1}{2}$   $\frac{3}{4}$   $\frac{1}{3}$   $\frac{2}{3}$   $\frac{1}{8}$   $\frac{3}{8}$   $\frac{5}{8}$   $\frac{7}{8}$

18 POINT PER FONT 50 CTS.

$\frac{1}{4}$   $\frac{1}{2}$   $\frac{3}{4}$   $\frac{1}{3}$   $\frac{2}{3}$   $\frac{1}{8}$   $\frac{3}{8}$   $\frac{5}{8}$   $\frac{7}{8}$

14 POINT PER FONT 50 CTS.

$\frac{1}{4}$   $\frac{1}{2}$   $\frac{3}{4}$   $\frac{1}{3}$   $\frac{2}{3}$   $\frac{1}{8}$   $\frac{3}{8}$   $\frac{5}{8}$   $\frac{7}{8}$

12 POINT PER FONT 50 CTS.

$\frac{1}{4}$   $\frac{1}{2}$   $\frac{3}{4}$   $\frac{1}{3}$   $\frac{2}{3}$   $\frac{1}{8}$   $\frac{3}{8}$   $\frac{5}{8}$   $\frac{7}{8}$

10 POINT PER FONT 50 CTS.

$\frac{1}{4}$   $\frac{1}{2}$   $\frac{3}{4}$   $\frac{1}{3}$   $\frac{2}{3}$   $\frac{1}{8}$   $\frac{3}{8}$   $\frac{5}{8}$   $\frac{7}{8}$

8 POINT PER FONT 50 CTS.

$\frac{1}{4}$   $\frac{1}{2}$   $\frac{3}{4}$   $\frac{1}{3}$   $\frac{2}{3}$   $\frac{1}{8}$   $\frac{3}{8}$   $\frac{5}{8}$   $\frac{7}{8}$

6 POINT PER FONT 50 CTS.

$\frac{1}{4}$   $\frac{1}{2}$   $\frac{3}{4}$   $\frac{1}{3}$   $\frac{2}{3}$   $\frac{1}{8}$   $\frac{3}{8}$   $\frac{5}{8}$   $\frac{7}{8}$

## Old Style Fractions

18 POINT 1 LB. FONT 80 CTS.

$\frac{1}{4}$   $\frac{1}{2}$   $\frac{3}{4}$   $\frac{1}{3}$   $\frac{2}{3}$   $\frac{1}{8}$   $\frac{3}{8}$   $\frac{5}{8}$   $\frac{7}{8}$  0

9 POINT 1 LB. FONT 60 CTS.

$\frac{1}{4}$   $\frac{1}{2}$   $\frac{3}{4}$   $\frac{1}{3}$   $\frac{2}{3}$   $\frac{1}{8}$   $\frac{3}{8}$   $\frac{5}{8}$   $\frac{7}{8}$  1/6 @ 3 1/2

12 POINT 1 LB. FONT 66 CTS.

$\frac{1}{4}$   $\frac{1}{2}$   $\frac{3}{4}$   $\frac{1}{3}$   $\frac{2}{3}$   $\frac{1}{8}$   $\frac{3}{8}$   $\frac{5}{8}$   $\frac{7}{8}$  1/6

@ 3 1/2

6 POINT 1 LB. FONT \$1 16

$\frac{1}{4}$   $\frac{1}{2}$   $\frac{3}{4}$   $\frac{1}{3}$   $\frac{2}{3}$   $\frac{1}{8}$   $\frac{3}{8}$   $\frac{5}{8}$   $\frac{7}{8}$  1/6 @ 3 1/2

## Gothic Fractions

18 POINT 1 LB. FONT 60 CTS.

$\frac{1}{4}$   $\frac{1}{2}$   $\frac{3}{4}$   $\frac{1}{3}$   $\frac{2}{3}$   $\frac{1}{8}$   $\frac{3}{8}$   $\frac{5}{8}$   $\frac{7}{8}$

12 POINT 1 LB. FONT 66 CTS.

$\frac{1}{4}$   $\frac{1}{2}$   $\frac{3}{4}$   $\frac{1}{3}$   $\frac{2}{3}$   $\frac{1}{8}$   $\frac{3}{8}$   $\frac{5}{8}$   $\frac{7}{8}$

6 POINT 1 LB. FONT \$1 16

$\frac{1}{4}$   $\frac{1}{2}$   $\frac{3}{4}$   $\frac{1}{3}$   $\frac{2}{3}$   $\frac{1}{8}$   $\frac{3}{8}$   $\frac{5}{8}$   $\frac{7}{8}$

## Gothic Cond Fractions

36 POINT 1 LB. FONT 54 CTS.

$\frac{1}{4}$   $\frac{1}{2}$   $\frac{3}{4}$   $\frac{1}{3}$   $\frac{2}{3}$   $\frac{1}{8}$   $\frac{3}{8}$   $\frac{5}{8}$   $\frac{7}{8}$

24 POINT 1 LB. FONT 56 CTS.

$\frac{1}{4}$   $\frac{1}{2}$   $\frac{3}{4}$   $\frac{1}{3}$   $\frac{2}{3}$   $\frac{1}{8}$   $\frac{3}{8}$   $\frac{5}{8}$   $\frac{7}{8}$

18 POINT 1 LB. FONT 60 CTS.

$\frac{1}{4}$   $\frac{1}{2}$   $\frac{3}{4}$   $\frac{1}{3}$   $\frac{2}{3}$   $\frac{1}{8}$   $\frac{3}{8}$   $\frac{5}{8}$   $\frac{7}{8}$

12 POINT 1 LB. FONT 66 CTS.

$\frac{1}{4}$   $\frac{1}{2}$   $\frac{3}{4}$   $\frac{1}{3}$   $\frac{2}{3}$   $\frac{1}{8}$   $\frac{3}{8}$   $\frac{5}{8}$   $\frac{7}{8}$

## Doric Fractions

48 POINT 1 LB. FONT 54 CTS.

$\frac{1}{4}$   $\frac{1}{2}$   $\frac{3}{4}$

44 POINT 1 LB. FONT 54 CTS.

$\frac{1}{4}$   $\frac{1}{2}$   $\frac{3}{4}$

40 POINT 1 LB. FONT 54 CTS.

$\frac{1}{4}$   $\frac{1}{2}$   $\frac{3}{4}$

36 POINT 1 LB. FONT 56 CTS.

$\frac{1}{4}$   $\frac{1}{2}$   $\frac{3}{4}$

20 POINT 1 LB. FONT 60 CTS.

$\frac{1}{4}$   $\frac{1}{2}$   $\frac{3}{4}$   $\frac{1}{3}$   $\frac{2}{3}$   $\frac{1}{8}$   $\frac{3}{8}$   $\frac{5}{8}$   $\frac{7}{8}$

16 POINT 1 LB. FONT 60 CTS.

$\frac{1}{4}$   $\frac{1}{2}$   $\frac{3}{4}$   $\frac{1}{3}$   $\frac{2}{3}$   $\frac{1}{8}$   $\frac{3}{8}$   $\frac{5}{8}$   $\frac{7}{8}$

12 POINT 1 LB. FONT 66 CTS.

$\frac{1}{4}$   $\frac{1}{2}$   $\frac{3}{4}$   $\frac{1}{3}$   $\frac{2}{3}$   $\frac{1}{8}$   $\frac{3}{8}$   $\frac{5}{8}$   $\frac{7}{8}$

6 POINT 1 LB. FONT \$1 16

$\frac{1}{4}$   $\frac{1}{2}$   $\frac{3}{4}$   $\frac{1}{3}$   $\frac{2}{3}$   $\frac{1}{8}$   $\frac{3}{8}$   $\frac{5}{8}$   $\frac{7}{8}$

## Special Figures

*The Prices Quoted  
are per Pound*

10 POINT EN NEWSPAPER FIGURES \$0 74

1 2 3 4 5 6 7 8 9 0

9 POINT EN NEWSPAPER FIGURES \$0 80

1 2 3 4 5 6 7 8 9 0

8 POINT EN NEWSPAPER FIGURES \$0 90

1 2 3 4 5 6 7 8 9 0

7 POINT EN NEWSPAPER FIGURES \$1 00

1 2 3 4 5 6 7 8 9 0

6 POINT EN NEWSPAPER FIGURES \$1 16

1 2 3 4 5 6 7 8 9 0

7 POINT FIVE-EIGHTH FIGURES \$1 00

1 2 3 4 5 6 7 8 9 0 \$

6 POINT THREE-QUARTER FIGURES \$1 16

1 2 3 4 5 6 7 8 9 0 \$

6 POINT FIVE-SEVENTH FIGURES \$1 16

1 2 3 4 5 6 7 8 9 0 \$

5½ POINT FIVE-SEVENTH FIGURES \$1 44

1 2 3 4 5 6 7 8 9 0 \$

## Cancelled Figures

11 POINT  
70 CTS. PER LB.

~~1 2 3 4 5 6 7 8 9 0~~

10 POINT  
74 CTS. PER LB.

~~1 2 3 4 5 6 7 8 9 0~~

9 POINT  
80 CTS. PER LB.

~~1 2 3 4 5 6 7 8 9 0~~

8 POINT  
90 CTS. PER LB.

~~1 2 3 4 5 6 7 8 9 0~~

AMERICAN TYPE FOUNDERS COMPANY

## Algebraic Signs

Prices given are for fonts

4½ POINT

1 2 3 4 5 6 7 8 9 10 11  
+ - × ÷ = ± □ △ > √

12 13 14 15  
∇ ∟ ∴ ∷

6 POINT \$2 40

1 2 3 4 5 6 7 8 9  
+ - × ÷ = ± □ □  
10 11 12 13 14 15 16  
△ < √ ∇ ∟ ∴ ∷

8 POINT NO 1 \$1 45

1 2 3 4 5 6  
+ - × ÷ = ± ∴  
7 8 9  
√ ∇ ∟ ∴ ∷

9 POINT NO 2 \$1 55

1 2 3 4 5 6  
+ - × ÷ = ± ∴  
7 8 9 10 11 12  
± □ △ < √ ∇ ∟ ∴ ∷  
13 14 15 16

11 POINT NO 2 \$1 35

1 2 3 4 5 6  
+ - × ÷ = ± ∴  
7 8 9 10 11 12  
± □ △ < √ ∇ ∟ ∴ ∷  
13 14 16 17

5 POINT \$2 05

1 2 3 4 5 6 7 8 9 10 11  
+ - × ÷ = ± □ △ > √  
12 13 14 15  
∇ ∟ ∴ ∷

7 POINT NO 1 \$1 55

1 2 3 4 5 6 7 8  
+ - × ÷ = ± □ △  
9 10 11 12 13 14  
√ ∇ ∟ ∴ ∷

8 POINT NO 2 \$1 80

1 2 3 4 5 6  
+ - × ÷ = ± ∴  
7 8 9 10 11 12  
± □ △ < √ ∇ ∟ ∴ ∷  
13 14 15 16

10 POINT NO 1 \$1 80

1 2 3 4 5 6 7  
+ - × ÷ = ± ∴  
8 9 10 11 12 13 14  
± □ △ < √ ∇ ∟ ∴ ∷  
15 16 17 18

12 POINT \$1 50

1 2 3 4 5 6  
+ - × ÷ = ± ∴  
7 8 9 10 11  
± □ □ △ >  
12 13 14 18 19  
√ ∇ ∟ ∴ ∷

5½ POINT \$1 70

1 2 3 4 5 6 7 8 9  
+ - × ÷ = ± □ □  
10 11 12 13 14 15  
< √ ∇ ∟ ∴ ∷

7 POINT NO 2 \$1 75

1 2 3 4 5 6 7 8 9  
+ - × ÷ = ± □ □  
10 11 12 13 14 15 16  
△ < √ ∇ ∟ ∴ ∷

9 POINT NO 1 \$1 55

1 2 3 4 5 6  
+ - × ÷ = ± ∴  
7 8 9 10 11  
□ △ √ ∇ ∟ ∴ ∷  
12 13 14

10 POINT NO 2 \$1 50

1 2 3 4 5 6  
+ - × ÷ = ± ∴  
7 8 9 10 11 12  
± □ △ < √ ∇ ∟ ∴ ∷  
13 14 15 16

14 POINT \$1 25

1 2 3 4 5  
+ - × ÷ = ∴  
6 7 8 9 10  
∴ ± □ □ △  
11 12 13 14 18 19  
> √ ∇ ∟ ∴ ∷

## Medical Signs

4½ POINT 50 CTS.

22 23 24 25  
5 3 9 R

7 POINT NO 1 35 CTS.

15 16 17 18  
5 5 9 R

9 POINT NO 1 35 CTS.

15 16 17 18  
5 5 9 R

11 POINT NO 2 35 CTS.

24 25 26 27  
5 5 9 R

5 POINT 40 CTS.

22 23 24 25  
5 3 9 R

7 POINT NO 2 35 CTS.

23 24 25 26  
5 5 9 R

9 POINT NO 2 35 CTS.

23 24 25 26  
5 5 9 R

12 POINT 35 CTS.

32 33 34 35  
5 5 9 R

5½ POINT 35 CTS.

33 34 35 36  
5 3 9 R

8 POINT NO 1 35 CTS.

11 12 13 14  
5 5 9 R

10 POINT NO 1 35 CTS.

24 25 26 27  
5 5 9 R

12 POINT NO 2 35 CTS.

1 2 3 4  
5 5 9 R

8 POINT 35 CTS.

58 59 60 61  
5 5 9 R

8 POINT NO 2 35 CTS.

23 24 25 26  
5 5 9 R

10 POINT NO 2 35 CTS.

23 24 25 26  
5 5 9 R

14 POINT 35 CTS.

32 33 34 35  
5 5 9 R

## Miscellaneous Signs

4½ POINT

16 17 18 19 20 21 26  
∇ @ % \$ # ∇ ∟ ∴ ∷

7 POINT NO 2 65 CTS.

17 18 19 20 21 22 27 28  
∇ @ % % c lb ∇ ∟ ∴ ∷

10 POINT NO 2 95 CTS.

17 18 19 20 21 22  
∇ @ % % c lb ∇ ∟ ∴ ∷

27 28 29 30 64

∇ # ∇ ∟ ∴ ∷

5 POINT

16 17 18 19 20 21 26  
∇ @ % \$ # ∇ ∟ ∴ ∷

8 POINT NO 1 \$1 25

17 18 19 20 21 22 27  
∇ @ % % c lb ∇ ∟ ∴ ∷

28 29 30 31 32 33 34

∇ # ∇ ∟ ∴ ∷

11 POINT NO 2 75 CTS.

18 19 20 21 22  
∇ @ % % c lb ∇ ∟ ∴ ∷

23 28 29 30

∇ ∇ # ∇ ∟ ∴ ∷

5½ POINT \$1 10

27 28 29 30 31 32 37  
∇ @ % \$ # ∇ ∟ ∴ ∷

9 POINT NO 2 80 CTS.

17 18 19 20 21 22 27  
∇ @ % % c lb ∇ ∟ ∴ ∷

12 POINT 75 CTS.

25 27 28 29 30 31  
∇ @ % % c lb ∇ ∟ ∴ ∷

35 37 38 39 40

∇ ∇ ∇ ∇ ∇ ∇ ∇ ∇

8 POINT \$1 00

52 53 54 55 56 57 62 64  
∇ @ % \$ # ∇ ∟ ∴ ∷

10 POINT NO 1 35 CTS.

29 30  
∇ ∇ ∇ ∇

14 POINT 65 CTS.

25 27 28 29 30  
∇ @ % % c lb ∇ ∟ ∴ ∷

31 36 37

∇ ∇ ∇ ∇

AMERICAN TYPE FOUNDERS COMPANY

# Almanac Signs

24 POINT

8 CENTS EACH



20 POINT

8 CENTS EACH



12 POINT NO 1

\$5 45

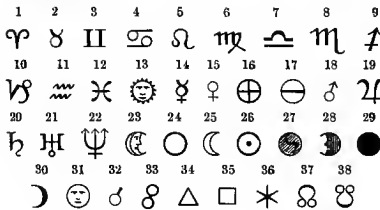

6 POINT NO 1

\$3 80



6 POINT NO 2

\$4 30

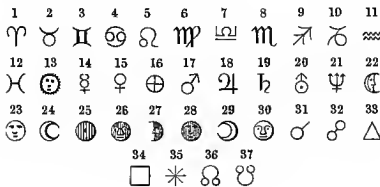

16 POINT

8 CENTS EACH



10 POINT NO 1

\$3 50

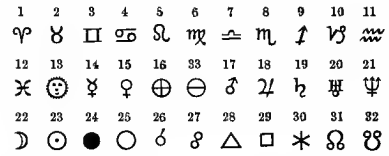

12 POINT NO 2

\$3 35



6 POINT

\$2 70



5 1/2 POINT

\$3 05



## Piece Accents

12 POINT NO 6

\$1 50



12 POINT

\$1 50



9 POINT

\$1 10



6 POINT

\$1 00



6 POINT NO 41

\$0 50



4 POINT

\$0 75



2 POINT

\$0 50

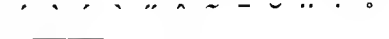

AMERICAN TYPE FOUNDERS COMPANY

# Time-Table Figures

**8 POINT WHITEFACE FIGURES NO 151**  
**PER LB. \$1 80**

<b>1.00</b>	Lv.	CHICAGO	Ar	<b>2.46</b>
<b>4.50</b>	Ar.	Galesburg	Lv	<b>10.16</b>
<b>5.35</b>	Lv.	Galesburg	Ar	<b>10.22</b>
<b>6.05</b>		Abingdon		<b>9.49</b>
<b>6.17</b>		St. Augustine.		<b>9.37</b>
		Avon		
<b>6.40</b>		Prairie City		<b>9.22</b>
<b>6.50</b>		Bushnell		<b>9.12</b>
<b>7.02</b>		Bardolph		<b>9.02</b>
<b>7.14</b>		Macomb		<b>8.49</b>
<b>7.20</b>		Colchester		<b>8.33</b>
<b>7.31</b>		Tennessee		<b>8.29</b>
<b>7.46</b>		Colmar		<b>8.22</b>
<b>8.03</b>		Plymouth		<b>8.12</b>

<b>9 POINT NO 31</b>		<b>8 POINT NO 32</b>
LIGHTFACE	PER LB. 90 CTS.	HEAVYFACE

<b>11 48</b>	Lv.	ST. LOUIS	Ar	<b>3 45</b>
<b>12 15</b>		Alton		<b>3 10</b>
		Texas Junction		<b>2 45</b>
<b>2 12</b>		Clarksville		<b>1 15</b>
<b>2 32</b>		Louisiana		<b>12 55</b>
<b>3 15</b>	Ar.	Hannibal	Lv	<b>12 12</b>
<b>3 55</b>	Lv.	Hannibal	Ar	<b>10 49</b>
<b>4 42</b>		Palmyra		<b>10 12</b>
<b>4 59</b>		Ely		<b>9 49</b>
<b>5 12</b>		Monroe		<b>9 36</b>
<b>5 25</b>		Hunnell		<b>9 24</b>
<b>5 35</b>		Lakenan		<b>9 12</b>
<b>5 46</b>		Shelbina		<b>8 46</b>
<b>6 31</b>		Macon		<b>8 22</b>

<b>7 POINT NO 31</b>		<b>7 POINT NO 32</b>
LIGHTFACE	PER LB. \$1 00	HEAVYFACE

<b>8 35</b>	Lv.	ST. LOUIS	Ar	<b>5 20</b>
<b>8 53</b>		East St. Louis		<b>5 00</b>
<b>9 35</b>		Upper Alton		<b>4 14</b>
<b>9 55</b>		Brighton		<b>3 55</b>
<b>10 05</b>		Piasa		<b>3 43</b>
<b>10 15</b>		Medora		<b>3 33</b>
<b>10 45</b>		Greenfield		<b>3 05</b>
<b>10 55</b>		Wrights		<b>2 53</b>
<b>11 10</b>		Whitehall		<b>2 39</b>
<b>11 20</b>		West Roodhouse		<b>2 27</b>
<b>11 47</b>		Winchester		<b>2 01</b>
<b>12 01</b>		Riggston		<b>1 49</b>
<b>12 12</b>		Chapin		<b>1 34</b>
<b>1 10</b>		Beardstown		<b>1 07</b>
<b>1 34</b>		Browning		<b>12 46</b>
<b>2 10</b>		Vermont		<b>12 12</b>
<b>2 20</b>		Table Grove		<b>11 43</b>

**6 POINT WHITEFACE FIGURES NO 152**  
**PER LB. \$3 00**

<b>7.23</b>	0	Lv. LOUISVILLE	Ar	<b>123</b>
<b>7.32</b>	74	Huntington		<b>47</b>
<b>7.43</b>	80	Ferdinand		<b>31</b>
<b>7.59</b>	85	Dale		<b>47</b>
<b>8.07</b>	88	Lincoln		<b>33</b>
<b>8.14</b>	91	Gentryville		<b>29</b>
<b>8.17</b>	93	Pigeon		<b>26</b>
<b>8.22</b>	96	Tenneson		<b>8.58</b>
<b>8.30</b>	201	De Gonias		<b>17</b>
<b>8.36</b>	105	Boonville		<b>13</b>
<b>8.40</b>	114	Dawson		<b>7</b>
<b>8.55</b>	118	Stevenson		<b>4</b>
<b>11.59</b>	122	Evansville		<b>0</b>

<b>6 POINT NO 31</b>		<b>6 POINT NO 32</b>
LIGHTFACE	PER LB. \$1 18	HEAVYFACE

<b>8 07</b>	0	Lv.	LOUISVILLE	Ar	<b>273</b>	<b>5 42</b>
<b>8 27</b>	6		New Albany		<b>267</b>	<b>5 10</b>
<b>8 39</b>	12		Edwardsville		<b>261</b>	<b>5 07</b>
<b>8 47</b>	15		Georgetown		<b>258</b>	<b>4 59</b>
<b>9 00</b>	21		Crandall		<b>252</b>	<b>4 47</b>
	22		Mott		<b>251</b>	
<b>9 06</b>	23		Corydon Junction		<b>249</b>	<b>4 43</b>
<b>9 13</b>	26		Ramsey		<b>246</b>	<b>4 35</b>
<b>9 20</b>	31		De Pauw		<b>243</b>	<b>4 28</b>
<b>9 31</b>	33		Milltown		<b>239</b>	<b>4 20</b>
<b>9 40</b>	38		Marengo		<b>235</b>	<b>4 11</b>
<b>9 52</b>	42		Temple		<b>238</b>	<b>4 02</b>
<b>10 00</b>	45		English		<b>227</b>	<b>3 55</b>

<b>5½ POINT NO 31</b>		<b>5½ POINT NO 32</b>
LIGHTFACE	PER LB \$1 44	HEAVYFACE

<b>8 30</b>	0	Lv.	PLEASANT HILL	Ar	<b>133</b>	<b>5 50</b>
<b>8 52</b>	10		Harrisonville		<b>123</b>	<b>5 25</b>
<b>9 23</b>	23		Archie		<b>110</b>	<b>4 57</b>
<b>9 36</b>	29		Andrain		<b>104</b>	<b>4 43</b>
<b>9 59</b>	39		Butler		<b>94</b>	<b>4 22</b>
<b>10 21</b>	48		Ovid		<b>85</b>	
<b>10 26</b>	50		Rich Hill		<b>83</b>	<b>3 55</b>
<b>10 40</b>	56		Arthur		<b>77</b>	<b>3 50</b>
<b>10 46</b>	59		Horton		<b>04</b>	<b>3 42</b>
<b>11 10</b>	69		Nevada		<b>64</b>	<b>3 36</b>
<b>11 20</b>	71		Nassau		<b>62</b>	<b>3 15</b>
<b>11 25</b>	75		Milo		<b>56</b>	<b>3 10</b>
<b>11 35</b>	82		Sheldon		<b>51</b>	<b>3 05</b>
<b>11 52</b>	87		Irwin		<b>46</b>	<b>2 55</b>
<b>12 03</b>	94		Lamar		<b>39</b>	<b>2 38</b>

<b>5 POINT NO 31</b>		<b>5 POINT NO 32</b>
LIGHTFACE	PER LB. \$1 80	HEAVYFACE

<b>10 10</b>	0	Lv.	KANSAS CITY	Ar	<b>760</b>	<b>5 46</b>
<b>10 17</b>	1		Grand Avenue		<b>759</b>	<b>5 38</b>
<b>10 30</b>	6		Kansas City Junc.		<b>754</b>	<b>5 25</b>
<b>10 38</b>	8		Centropolis		<b>752</b>	<b>5 16</b>
<b>10 45</b>	11		Leeds		<b>749</b>	<b>5 09</b>
<b>11 00</b>	18		Dodson		<b>742</b>	<b>4 56</b>
<b>11 10</b>	21		Red Bridge		<b>739</b>	<b>4 47</b>
<b>11 19</b>	25		Martin City		<b>735</b>	<b>4 37</b>
<b>11 25</b>	28		Newington		<b>732</b>	<b>4 32</b>
<b>11 42</b>	34		Stillwell		<b>726</b>	<b>4 22</b>
<b>11 54</b>	39		Bucyrus		<b>721</b>	<b>4 10</b>
<b>11 59</b>	43		Chiles		<b>717</b>	<b>3 53</b>
<b>12 06</b>	46		Wagstaff		<b>714</b>	<b>3 47</b>
<b>12 12</b>	54		Prairie		<b>706</b>	<b>3 27</b>
<b>12 42</b>	61		Osawatimie		<b>699</b>	<b>3 08</b>
<b>1 00</b>	66		O'Brien		<b>694</b>	<b>2 50</b>

*These Figures are cast on en set*

**AMERICAN TYPE FOUNDERS COMPANY**



# MAIL LIST TYPE

## Time-Saving Mail List Type

Example, used without Logotypes

Theo. J. DeVinne 12Jan92  
NEW YORK, N. Y.

J. S. Cushing 30Mar72  
BOSTON, MASS.

Sherman Bros. 11Sep73  
PHILADELPHIA, PA.

Pope Bicycle Co. 6Aug95  
Printing Department,  
HARTFORD, CONN.

Bureau of Engraving,  
WASHINGTON, D. C.

Example, in combination with Mail List Logotypes No. 32

Chauncey Depew 3 JUNE 91

Mary Walker 31 OCT 83

James J. Corbett 3 MAR 96

Abe Slupsky 30 JULY 98

James J. Blaine 3 DEC 89

Theo. Roosevelt 4 APR 79

B. Hesselberg 3 SEP 95

Dora Bloomer 12 FEB 95

Li Hung Chung 3 AUG 95

Example, in combination with Mail List Logotypes No. 41 and 10 Point Clarendon

**SQUABTOWN**

Flora McFlimsey 30 88 90

Jack Ketch 12 88 91

M E Stiggins 22 88 96

Management 15 88 99

Molly Maguire 11 88 88

**HUNGRY HILL**

Tam O Shanter 8 88 95

Cholera Morbus 13 88 94

Ragbag Association 7 88 80

## Mail List Type

Example, in combination with Mail List Logotypes No. 42 and 10 Point Clarendon

Mrs Swallowswill 7 Aug 98

O B Server 27 Nov 94

Box No 5843 31 Oct 89

**CORNCOB GULCH**

Hon B Faithful 25 Sep 89

Ben Bolt Esq 10 Feb 90

Miss O B Joyful 20 Jan 89

Signor Paganini 2 July 96

Dr Betsey Baker 8 Apr 91

Rev C O Malley 25 Jne 88

The above Mail List Type, with Logotypes, is furnished at the regular rates of Roman letter. A complete font for 1000 names will weigh as follows:—Roman, 30 pounds; Clarendon, 6½ pounds; Abbreviations, 3½ pounds. Extra sorts, amounting to 20 pounds, will be required where Countries and States are added, for which a special sort-order must be sent

## Mail List Logotypes

10 POINT NO 41

Jan	Feb	Mar	Apr	May	Jun	Jul	Aug	Sep	Oct	Nov	Dec
Miss	Mrs	Mrs	Mrs	Mrs	Mrs	Mrs	Mrs	Mrs	Mrs	Mrs	Mrs
Box	Box	Box	Box	Box	Box	Box	Box	Box	Box	Box	Box

Figures on 4-10-em set

10 POINT NO 42

Jan	Feb	Mar	Apr	May	Jun	Jul	Aug	Sep
Oct	Nov	Dec	Hon	Rev	Dr	Mrs	Miss	Box

10 POINT NO 32

Jan	Feb	Mar	Apr	May	Jun	Jul	Aug	Sep	Oct	Nov	Dec
Box	Box	Box	Box	Box	Box	Box	Box	Box	Box	Box	Box

These Logotypes may be used with any Series of Mail List Type

# DESCRIPTION OF SELF SPACING TYPE



THE common widths of book pages, miscellaneous jobs and newspaper columns are some number of Pica ems, therefore the Pica em is taken as the basis for Self Spacing type. The thinnest space in all fonts is some exact fraction of a Pica, and this fraction of Pica is called the unit of measure. All characters, spaces and quads in the font are made some exact multiple of this unit in width, so that the sizes of all faces will work perfectly together in the regular labor-saving measures. This unit of measure may be one-sixth, one-seventh, one-eighth, one-ninth, etc., of a Pica em, as may be desired, to produce condensed, medium or extended faces. The following table gives the sizes of bodies, units of measure, and lengths of alphabets. In the first column will be found the various sizes of bodies; in the second, the number of units contained in one em Pica, and in the third the measurements of a lower case alphabet in the ems of each particular body:

BODY	Number Units to Pica em	Length of Alphabet
5½ Point (Agate).....	12	167/8
6 Point (Nonpareil)....	12	15½
6 Point (Nonpareil)....	11	17
7 Point (Minion).....	11	14½
7 Point (Minion).....	10	16
8 Point (Brevier).....	11	12¾
8 Point (Brevier).....	10	14¾
8 Point (Brevier).....	9	15½
9 Point (Bourgeois) ..	10	12¾
9 Point (Bourgeois) ..	9	13¾
10 Point (Lg. Primer)..	9	12¾
10 Point (Lg. Primer)..	8	14
11 Point (Small Pica)..	8	12¾
11 Point (Small Pica)..	7	14½
12 Point (Pica).....	7	13¼

In the foregoing table will be found a Nonpareil with one-twelfth of Pica as the unit of measure. This is one-sixth of the body of Nonpareil, or the six-to-em space, and preserves in this particular font the old three-to-em space and the old en and em

quads. The same is true of the Brevier on one-ninth, Bourgeois on one-eighth, and Pica on one-sixth of Pica.

In a complete font of the old kind of body type there are about 190 widths of bodies. Appended is a table showing the different widths of bodies of Self Spacing. It will be readily seen that there are but nine widths of bodies all told, and that the four-unit width predominates largely over any other, there being fifty-nine characters of this width. We omit the Italic characters from the table, as they go on the same widths of bodies and are interchangeable with the Roman:

1 unit—Space.....	1
2 nnits—Space, f i j l , ; . - ' ! I J '   .....	16
3 nnits—Quad, c e r s t z s z I J ? ) [ * † ‡ §    ¶ - ° .....	22
4 nnits—Quad, a h d g h k n o p q u v x y f i f f \$ £ 1 2 3 4 5 6 7 8 9 0 A B C D E F G L N O P Q R T U V X Y & S Z . - }   {   } \	59
5 units—æ A B C D E F G L N O P Q R T U V Y H K M.....	21
6 nnits—Quad, m w œ w æ œ ð ð H K X & lb ¶ @ - ... ¼ ½ ¾ ⅓ ⅔ ⅕ ⅙ ⅚ ⅛ ⅜ ⅝ ⅞	27
7 units—W M.....	2
8 units—CE Æ.....	2
12 units—Quad, ..... —  	9
9 sizes. Roman characters.....	155
Italic characters.....	77
Total.....	232

Any compositor can see that no combination of units can be made that will not come within a certain number of exact units of filling a line. If a line of matter lacks, it must lack one or more exact units.

Self Spacing type sets line for line with the ordinary Roman, where the lengths of the alphabets are the same.

Repeated experiments with the new type have shown that the average compositor gains about twenty-five per cent. in speed, with no trouble in justification whatever.

In the matter of the correction of proofs the gain is enormous. Say there is an "a" for "e"; as "a" is four units wide and "e" three, "e" and one unit space justify the line perfectly. Even this measure of trouble is avoided in many instances. As twenty-eight of the most common lower case characters are of the same width, they can be substituted for one another without the change of a space.

This type is of greater durability, as it is always on its feet and is therefore not worn by "pounding."

In tabular work there is a great gain in speed and neatness. By the addition of a new character, viz: "|", it is easy to set perpendicular lines of any length, line upon line.

It may be repeated that the compositor has nothing to learn in Self Spacing type. There is but a single direction to be given—to set that which looks like the em quad (six unit quad) with the nick out.

Whoever will study the principle on which Self Spacing type is based, will readily admit that it is bound to secure easy and perfect justification, greatly increased speed and consequent enormous saving, simplicity and rapidity of proof correction, and increased accuracy and ease in the setting of tables. All these points are beyond question, as certainly as the proposition that two and two make four is not open to argument. No rational person can doubt them.

The following piece of composition was done in a 12½-em measure stick, and set line upon line in the ordinary manner of straight reading matter, the lower part being leaded to show the method of setting.

No. 1	No. 2	No. 3	No. 4.	No. 5	No. 6	No. 7
i and	i HX	i DLE	s aturs	s MP	i dim	' D1N
s mit	I NK	s MIT	is thm	s NK	s mit	s MIT
b rot	S LY	B AIT	ne ver	fr d	L Y	B rot
s tly	E LS	M ine	Th urs	ci si	L S	M tly
m an	H IE	L IED	lin c	fo rn	m IE	L nd
su it	SI SI	SE ES	ni ne	fi ve	so IS	SE at
no ts	NI X	PU SS	in cre	asi mi	X PA	st BI
No is	SA T	No is	comp oz	ME T	MA D	SU it
gl ad	FO Z	FL IT	Repea ti	gl a	S BN	S FO
mit e	OH I	SEA s	second r	sn il	I SEA	I HO
still i	\$34	NOT i	beat	th	this i	NOT
						234 i

To further explain and illustrate the ease with which table work is done with Self Spacing type, we show above an example of miscellaneous justifications, which is absolutely impossible to accomplish with the old kind of type. In column No. 1 the first line begins with the lower case "i", two units wide, which is followed by the upright dash "|", two units, and the characters "a", four units, "n", four units, "d", four units, comprising sixteen units to accurately fill the column. The second line begins with the letter "s," three units wide, which throws the space rule one unit further to the right than in the preceding line. In each succeeding line lower case characters are used to the total width of sixteen units, and such characters are chosen for the first part thereof as will admit of advancing the space rule to the right exactly one unit in each succeeding line.

In the other columns the same plan is followed, the only change being the substitution of caps, small caps, figures, etc., for the lower case characters, all columns coming perfectly justified inside the perpendicular lines.

## Self Spacing Signs

*These signs are furnished for every face of Self Spacing type, and may be used with point system bodies. When ordering state size of body and (if Self Spacing) number of face wanted.*

PRICE \$1 00 PER FONT EACH SIZE

× + - = ± : :: ÷ ÷ < > Δ □ √ √ R D 3 3 % % ™ ✕ Ÿ +  
 × + - = ± : :: ÷ ÷ < > Δ □ √ √ R D 3 3 % % ™ ✕ Ÿ +  
 × + - = ± : :: ÷ ÷ < > Δ □ √ √ R D 3 3 % % ™ ✕ Ÿ +  
 × + - = ± : :: ÷ ÷ < > Δ □ √ √ R D 3 3 % % ™ ✕ Ÿ +  
 × + - = ± : :: ÷ ÷ < > Δ □ √ √ R D 3 3 % % ™ ✕ Ÿ +  
 × + - = ± : :: ÷ ÷ < > Δ □ √ √ R D 3 3 % % ™ ✕ Ÿ +

AMERICAN TYPE FOUNDERS COMPANY

# Self Spacing Modern Roman and Italic

5½ POINT SELF SPACING ROMAN NO 19½

Unit of measure of this font is 12 to Pica

THE common widths of book pages, miscellaneous jobs and newspaper columns are some number of Pica ems, therefore the Pica em is taken as the basis for Self Spacing type. The thinnest space in fonts is some exact fraction of a Pica, and this fraction of Pica is called the unit of measure. All characters, spaces and quads in the font are made some exact multiple of this unit in width, so that the sizes of all faces will work perfectly together in the regular labor-saving measures. This unit of measure may be one-sixth, one-seventh, one-eighth, one-ninth, etc., of a Pica em, as may be desired, to produce condensed, medium or extended faces. A detailed description is printed in this Specimen Book. Self Spacing type sets line for line with the ordinary Roman, where the lengths of the alphabets are the same. Repeated experiments with the new type have shown that the average compositor gains about twenty-five per cent. in speed, with no trouble in justification whatever. In the matter of the correction of proofs the gain is enormous. Say there is an "a" for an "e"; as "a" is four units wide and "e" three, "e" and a one-unit space justify the line perfectly. Even this measure of trouble is avoided in many instances. As twenty-eight of the most common lower case characters are of the same width, they can be substituted for one another without the change of a space. *This type is of greater durability as it is always on its feet and is therefore not worn by "pounding."* In tabular work there is a great gain in speed and neatness. It may be repeated that the com-

Lower case a to z, 16¼ ems

ABCDEFGHIJKLMN OPQRSTUVWXYZ  
1234567890

6 POINT SELF SPACING ROMAN NO 36¼

Unit of measure of this font is 12 to Pica

THE common widths of book pages, miscellaneous jobs and newspaper columns are some number of Pica ems, therefore the Pica em is taken as the basis for Self Spacing type. The thinnest space in all fonts is some exact fraction of a Pica, and this fraction of Pica is called the unit of measure. All characters, spaces and quads in the font are made some exact multiple of this unit in width, so that the sizes of all faces will work perfectly together in the regular labor-saving measures. This unit of measure may be one-sixth, one-seventh, one-eighth, one-ninth, etc., of a Pica em, as may be desired, to produce condensed, medium or extended faces. A detailed description is printed in this Specimen Book. Self Spacing type sets line for line with the ordinary Roman, where the lengths of the alphabets are the same. Repeated experiments with the new type have shown that the average compositor gains about twenty-five per cent. in speed, with no trouble in justification whatever. In the matter of the correction of proofs the gain is enormous. Say there is an "a" for an "e"; as "a" is four units wide and "e" three, "e" and a one-unit space justify the line perfectly. Even this measure of trouble is avoided in many instances. As twenty-eight of the most common lower case characters are of the same width, they can be substituted for one another without the change of a space. *This type is of greater durability as it is always on its feet*

Lower case a to z, 15½ ems

ABCDEFGHIJKLMN OPQRSTUVWXYZ  
1234567890

7 POINT SELF SPACING ROMAN NO 38¼

Unit of measure of this font is 10 to Pica

THE common widths of book pages, miscellaneous jobs and newspaper columns are some number of Pica ems, therefore the Pica em is taken as the basis for Self Spacing type. The thinnest space in all fonts is some exact fraction of a Pica, and this fraction of Pica is called the unit of measure. All characters, spaces and quads in the font are made some exact multiple of this unit in width, so that the sizes of all faces will work perfectly together in the regular labor-saving measures. This unit of measure may be one-sixth, one-seventh, one-eighth, one-ninth, etc., of a Pica em, as may be desired, to produce condensed, medium or extended faces. A detailed description is printed in this Specimen Book. Self Spacing type sets line for line with the ordinary Roman, where the lengths of the alphabets are the same. Repeated experiments with the new type have shown that the average compositor gains about twenty-five per cent. in speed, with no trouble in justification whatever. In the

Lower case a to z, 16 ems

ABCDEFGHIJKLMN OPQRSTUVWXYZ  
1234567890

AMERICAN TYPE FOUNDERS COMPANY

# Self Spacing Modern Roman and Italic

8 POINT SELF SPACING ROMAN NO 34½

Unit of measure of this font is 10 to Pica

THE common widths of book pages, miscellaneous jobs and newspaper columns are some number of Pica ems, therefore the Pica em is taken as the basis for Self Spacing type. The thinnest space in all fonts is some exact fraction of a Pica, and this fraction of Pica is called the unit of measure. All characters, spaces and quads in the font are made some exact multiple of this unit in width, so that the sizes of all faces will work perfectly together in the regular labor-saving measures. This unit of measure may be one-sixth, one-seventh, one-eighth, one-ninth, etc., of a Pica em, as may be desired, to produce condensed, medium or extended faces. A detailed description is printed in this Specimen Book. Self Spacing type sets line for line with the ordinary Roman, where the lengths of the alphabets are the same. Repeated experiments with the new type have shown that the average compositor gains about twenty-five per cent. in speed, with no trouble in justification whatever. In the matter of correction of proofs the gain is enormous. Say there is an "a" for an "e," as "a" is four units wide and "e" three, "e" and a one-unit space justify the line perfectly. Even this measure of trouble is avoided in many instances. As twenty-eight of the most common lower case characters are of the same width, they can be substituted for one another without the change of a space. *This type is of greater durability as it is always on its feet and is therefore not worn by "pounding."* In tabular work there is a great

Lower case a to z, 14¼ ems

ABCDEFGHIJKLMN OPQRSTUVWXYZ

1234567890

8 POINT SELF SPACING ROMAN NO 48½

Unit of measure of this font is 9 to Pica

THE common widths of book pages, miscellaneous jobs and newspaper columns are some number of Pica ems, therefore the Pica em is taken as the basis for Self Spacing type. The thinnest space in all fonts is some exact fraction of a Pica, and this fraction of Pica is called the unit of measure. All characters, spaces and quads in the font are made some exact multiple of this unit in width, so that the sizes of all faces will work perfectly together in the regular labor-saving measures. This unit of measure may be one-sixth, one-seventh, one-eighth, one-ninth, etc., of a Pica em, as may be desired, to produce condensed, medium or extended faces. A detailed description is printed in this Specimen Book. Self Spacing type sets line for line with the ordinary Roman, where the lengths of the alphabets are the same. Repeated experiments with the new type have shown that the average compositor gains about twenty-five per cent. in speed, with no trouble in justification whatever. In the matter of the correction of proofs the gain is enormous. Say there is an "a" for an "e," as "a" is four units wide and "e" three, "e" and a one-unit space justify the line perfectly. Even this measure of trouble is avoided in many instances. As twenty-eight of the most common lower case characters are of the same width, they can be substituted for one another without the change of a

Lower case a to z, 15½ ems

ABCDEFGHIJKLMN OPQRSTUVWXYZ

1234567890

AMERICAN TYPE FOUNDERS COMPANY

## Self Spacing Modern Roman and Italic

9 POINT SELF SPACING ROMAN NO 32½

Unit of measure of this font is 9 to Pica

THE common widths of book pages, miscellaneous jobs and newspaper columns are some number of Pica ems, therefore the Pica em is taken as the basis for Self Spacing type. The thinnest space in all fonts is some exact fraction of a Pica, and this fraction of Pica is called the unit of measure. All characters, spaces and quads in the font are made some exact multiple of this unit in width, so that the sizes of all faces will work perfectly together in the regular labor-saving measures. This unit of measure may be one-sixth, one-seventh, one-eighth, one-ninth, etc., of a Pica em, as may be desired, to produce condensed, medium or extended faces. A detailed description is printed in this Specimen Book. Self Spacing type sets line for line with the ordinary Roman, where the lengths of the alphabets are the same. Repeated experiments with the new type have shown that the average compositor gains about twenty-five per cent. in speed, with no trouble in justification whatever. In the matter of the correction of *proofs the gain is enormous. Say there is an "a" for an "e"; as "a" is four units wide and "e" three, "e" and a one-unit space justify the line perfectly. Even this measure of trouble*

Lower case a to z, 13¾ ems

ABCDEFGHIJKLMN OPQRSTUVWXYZ

1234567890

10 POINT SELF SPACING ROMAN NO 17½

Unit of measure of this font is 8 to Pica

THE common widths of book pages, miscellaneous jobs and newspaper columns are some number of Pica ems, therefore the Pica em is taken as the basis for Self Spacing type. The thinnest space in all fonts is some exact fraction of a Pica, and this fraction of Pica is called the unit of measure. All characters, spaces and quads in the font are made some exact multiple of this unit in width, so that the sizes of all faces will work perfectly together in the regular labor-saving measures. This unit of measure may be one-sixth, one-seventh, one-eighth, one-ninth, etc., of a Pica em, as may be desired, to produce condensed, medium or extended faces. A detailed description is printed in this Specimen Book. Self Spacing type sets line for line with the ordinary Roman, where the lengths of the alphabets are the same. Repeated experiments with the new type have shown that the average compositor

Lower case a to z, 14 ems

ABCDEFGHIJKLMN OPQRSTUVWXYZ

1234567890

AMERICAN TYPE FOUNDERS COMPANY

## Self Spacing Modern Roman and Italic

11 POINT SELF SPACING ROMAN NO 39½

Unit of measure of this font is 8 to Pica

THE common widths of book pages, miscellaneous jobs and newspaper columns are some number of Pica ems, therefore the Pica em is taken as the basis for Self Spacing type. The thinnest space in all fonts is some exact fraction of a Pica, and this fraction of Pica is called the unit of measure. All characters, spaces and quads in the font are made some exact multiple of this unit in width, so that the sizes of all faces will work perfectly together in the regular labor-saving measures. This unit of measure may be one-sixth, one-seventh, one-eighth, one-ninth, etc., of a Pica em, as may be desired, to produce condensed, medium or extended faces. A detailed description is printed in this *Specimen Book. Self Spacing type sets line for line with the ordinary Roman, where the lengths of the alphabets are the same. Repeated experiments with these*

Lower case a to z, 12¾ ems

ABCDEFGHIJKLMNOPQRSTUVWXYZ

1234567890

12 POINT SELF SPACING ROMAN NO 31¾

Unit of measure of this font is 7 to Pica

THE common widths of book pages, miscellaneous jobs and newspaper columns are some number of Pica ems, therefore the Pica em is taken as the basis for Self Spacing type. The thinnest space in all fonts is some exact fraction of a Pica, and this fraction of Pica is called the unit of measure. All characters, spaces and quads in the font are made some exact multiple of this unit in width, so that the sizes of all faces will work perfectly together in the regular labor-saving measures. This unit of measure may be one-sixth, one-seventh, one-eighth, one-ninth, etc., of a Pica em, as may be desired, to produce condensed, medium or extended faces. Repeat

Lower case a to z, 13¼ ems

ABCDEFGHIJKLMNOPQRSTUVWXYZ

1234567890

AMERICAN TYPE FOUNDERS COMPANY

# Self Spacing Old Style Roman and Italic

6 POINT SELF SPACING OLD STYLE NO 27

Unit of measure of this font is 11 to Pica

THE common widths of book pages, miscellaneous jobs and newspaper columns are some number of Pica ems, therefore the Pica em is taken as the basis for Self Spacing type. The thinnest space in all fonts is some exact fraction of a Pica, and this fraction of Pica is called the unit of measure. All characters, spaces and quads in the font are made some exact multiple of this unit in width, so that the sizes of all faces will work perfectly together in the regular labor-saving measures. This unit of measure may be one-sixth, one-seventh, one-eighth, one-ninth, etc., of a Pica em, as may be desired, to produce condensed, medium or extended faces. A detailed description is printed in this Specimen Book. *Self Spacing type sets line for line with the ordinary Roman, where the lengths of the alphabets*

Lower case a to z, 17 ems

ABCDEFGHIJKLMN OPQRSTUVWXYZ

1234567890

8 POINT SELF SPACING OLD STYLE NO 22

Unit of measure of this font is 10 to Pica

THE common widths of book pages, miscellaneous jobs and newspaper columns are some number of Pica ems, therefore the Pica em is taken as the basis for Self Spacing type. The thinnest space in all fonts is some exact fraction of a Pica, and this fraction of Pica is called the unit of measure. All characters, spaces and quads in the font are made some exact multiple of this unit in width, so that the sizes of all faces will work perfectly together in the regular labor-saving measures. *This unit of measure may be one-sixth, one*

Lower case a to z, 14 $\frac{1}{2}$  ems

ABCDEFGHIJKLMN OPQRSTUVWXYZ

1234567890

9 POINT SELF SPACING OLD STYLE NO 28

Unit of measure of this font is 9 to Pica

THE common widths of book pages, miscellaneous jobs and newspaper columns are some number of Pica ems, therefore the Pica em is taken as the basis for Self Spacing type. The thinnest space in all fonts is some exact fraction of a Pica, and this fraction of Pica is called the unit of measure. All characters, spaces and quads in the font are made some exact multiple of this unit in width, so that the sizes of all faces

Lower case a to z, 13 $\frac{3}{4}$  ems

ABCDEFGHIJKLMN OPQRSTUVWXYZ

1234567890

10 POINT SELF SPACING OLD STYLE NO 29

Unit of measure of this font is 9 to Pica

THE common widths of book pages, miscellaneous jobs and newspaper columns are some number of Pica ems, therefore the Pica em is taken as the basis for Self Spacing type. The thinnest space in all fonts is some exact fraction of a Pica, and this fraction of Pica is called the unit of measure. All characters, spaces and quads in the font are made some exact multiple of this unit in width, so that the sizes of all faces

Lower case a to z, 12 $\frac{3}{4}$  ems

ABCDEFGHIJKLMN OPQRSTUVWXYZ

1234567890

AMERICAN TYPE FOUNDERS COMPANY



## Self Spacing Old Style Roman and Italic

- 6 -

10 POINT SELF SPACING OLD STYLE NO 24

Unit of measure of this font is 8 to Pica

THE common widths of book pages, miscellaneous jobs and newspaper columns are some number of Pica ems, therefore the Pica em is taken as the basis for Self Spacing type. The thinnest space in all fonts is some exact fraction of a Pica, and this fraction of Pica is called the unit of measure. All characters, spaces and quads in the font are made some exact multiple of this unit in width, so that the sizes of all faces will work *perfectly together in the regular labor-saving measures. This unit of measure may be one-sixth, or one-*

Lower case a to z, 14 ems

ABCDEFGHIJKLMN OPQRSTUVWXYZ  
1 2 3 4 5 6 7 8 9 0

11 POINT SELF SPACING OLD STYLE NO 25

Unit of measure of this font is 8 to Pica

THE common widths of book pages, miscellaneous jobs and newspaper columns are some number of Pica ems, therefore the Pica em is taken as the basis for Self Spacing type. The thinnest space in all fonts is some exact fraction of a Pica, and this fraction of Pica is called the unit of measure. All characters, spaces and quads in the font are made some exact multiple of this *unit in width, so that the sizes of all faces will work perfectly together in the regular labor-saving measure*

Lower case a to z, 12 $\frac{2}{3}$  ems

ABCDEFGHIJKLMN OPQRSTUVWXYZ  
1 2 3 4 5 6 7 8 9 0

12 POINT SELF SPACING OLD STYLE NO 26

Unit of measure of this font is 7 to Pica

THE common widths of book pages, miscellaneous jobs and newspaper columns are some number of Pica ems, therefore the Pica em is taken as the basis for Self Spacing type. The thinnest space in all fonts is some exact fraction of a Pica, and this fraction of Pica is called the *unit of measure. All characters, spaces and quads in the font are made some exact multiple*

Lower case a to z, 13 $\frac{1}{4}$  ems

ABCDEFGHIJKLMN OPQRSTUVWXYZ  
1 2 3 4 5 6 7 8 9 0

---

AMERICAN TYPE FOUNDERS COMPANY

# Self Spacing Old Style Italic

6 POINT SELF SPACING OLD STYLE ITALIC NO 27

CIRCULAR FONT \$7 00

*The common widths of book pages, miscellaneous jobs and newspaper columns are some number of Pica ems, therefore the Pica em is taken as the basis for Self Spacing type. The thinnest space in all fonts is some exact fraction of a Pica, and this fraction of Pica is called the unit of measure. All characters, spaces and quads in the font are made some exact multiple of this unit in width, so that the sizes of all faces will work perfectly together in the regular labor-saving measures. This unit of measure may be one-sixth, one-seventh, one-eighth, one-ninth, etc., of a Pica em, as may be desired, to*

8 POINT SELF SPACING OLD STYLE ITALIC NO 22

CIRCULAR FONT \$5 40

*The common widths of book pages, miscellaneous jobs and newspaper columns are some number of Pica ems, therefore the Pica em is taken as the basis for Self Spacing type. The thinnest space in all fonts is some exact fraction of a Pica, and this fraction of Pica is called the unit of measure. All characters, spaces and quads in the font are made some exact multiple of this unit in width, so that the sizes of all*

9 POINT SELF SPACING OLD STYLE ITALIC NO 28

CIRCULAR FONT \$4 80

*The common widths of book pages, miscellaneous jobs and newspaper columns are some number of Pica ems, therefore the Pica em is taken as the basis for Self Spacing type. The thinnest space in all fonts is some exact fraction of a Pica, and this fraction of Pica is called the unit of measure. All characters, spaces and quads in the font are made some exact multiple of*

10 POINT SELF SPACING OLD STYLE ITALIC NO 24

CIRCULAR FONT \$4 45

*The common widths of book pages, miscellaneous jobs and newspaper columns are some number of Pica ems, therefore the Pica em is taken as the basis for Self Spacing type. The thinnest space in all fonts is some exact fraction of a Pica, and this fraction of Pica is called the*

11 POINT SELF SPACING OLD STYLE ITALIC NO 25

CIRCULAR FONT \$4 20

*The common widths of book pages, miscellaneous jobs and newspaper columns are some number of Pica ems, therefore the Pica em is taken as the basis for Self Spacing type. The thinnest space in all fonts is some exact fraction of a Pica, and this fraction of Pica is called the*

12 POINT SELF SPACING OLD STYLE ITALIC NO 26

CIRCULAR FONT \$3 95

*The common widths of book pages, miscellaneous jobs and newspaper columns are some number of Pica ems, therefore the Pica em is taken as the basis for Self Spacing type. The thinnest space in all fonts is some exact fraction of a*

*Spaces and Quads are included with each font*

AMERICAN TYPE FOUNDERS COMPANY

## Self Spacing Old Style Bold

-- 0 --

8 POINT

30 A 50 a \$3 30

**THIS SERIES of Old Style Bold was cut after many inquiries for a Job Face that could be used with Self Spacing to emphasize certain words. All sizes shown on this page will line and justify with the corresponding sizes of our Old Style Self Spacing Series. Repeated experiments have shown that the average Compositor gains about 25 per cent. with no trouble in justification whatever. In the matter of correction of proofs the saving is something**

9 POINT

28 A 45 a \$3 35

**THIS SERIES of Old Style Bold was cut after many inquiries for a Job Face that could be used with Self Spacing to emphasize certain words. All sizes shown above will line and justify with the corresponding sizes of our Old Style Self Spacing Series. Repeated experiments with Self Spacing Type have shown that the average compositor gains about 25 per cent. in speed with no trouble in justification whatever.**

10 POINT

25 A 40 a \$3 50

**THIS SERIES of Old Style Bold was cut after many inquiries for a Job Face that could be used with Self Spacing to emphasize certain words. All sizes shown on this page will line and justify with the corresponding sizes of all our Old Style Self Spacing Series. Repeated experiments with Self Spacing Type have shown that the average compositor gains about 25 per**

12 POINT

25 A 38 a \$4 00

**THIS SERIES of Old Style Bold was cut after many inquiries for a Job Face that could be used with Self Spacing to emphasize certain words. All sizes shown on this page will line and justify with the corresponding sizes of our Old Style Self Spacing Series. Repeated experiments with Self Spacing Type have shown that the aver-**

---

AMERICAN TYPE FOUNDERS COMPANY

## Franklin Series

5 POINT OLD STYLE NO 79

THIS BOOKISH INCLINATION at length determined my father to make me a printer, though he had already one son (James) of that profession. In 1717 my brother James returned from England with a press and letters to set up his business in Boston. I liked it much better than that of my father, but still had a hankering for the sea. To prevent the apprehended effect of such inclination, my father was impatient to have me bound to my brother. I stood out some time, but at last was persuaded, and signed the indentures when I was yet but twelve years old. I was to serve as an apprentice till I was twenty-one years of age, only I was to be allowed journeyman's wages during the last year. In a little time I made great progress in the business, and became a useful hand to my brother. I had now access to better books. An acquaintance with the apprentices of booksellers enabled me sometimes to borrow a small one, which I was careful to

Lower case a to z, 14½ ems

6 POINT OLD STYLE NO 79

THIS BOOKISH INCLINATION at length determined my father to make me a printer, though he had already one son (James) of that profession. In 1717 my brother James returned from England with a press and letters to set up his business in Boston. I liked it much better than that of my father, but still had a hankering for the sea. To prevent the apprehended effect of such an inclination, my father was impatient to have me bound to my brother. I stood out some time, but at last was persuaded, and signed the indentures when I was yet but twelve years old. I was to serve as an apprentice till I was twenty-one years of age, only I was to be allowed journeyman's wages

Lower case a to z, 13½ ems

7 POINT OLD STYLE NO 79

THIS BOOKISH INCLINATION at length determined my father to make me a printer, though he had already one son (James) of that profession. In 1717 my brother James returned from England with a press and letters to set up his business in Boston. I liked it much better than that of my father, but still had a hankering for the sea. To prevent the apprehended effect of such an inclination, my father was impatient to have me bound to my brother. I stood out for some time but at last was persuaded, and signed the indentures when I was yet but twelve years old. I was to serve as an apprentice till I was twenty-one years of age, only I was allowed journeyman's wages during the last year. In a little time I made great progress in the business, and became a useful hand to my brother. I had now access to better books. An acquaintance with the apprentices of booksellers enabled me sometimes to borrow a small one, which I was careful to return soon, and clean. Often I sat up in my chamber the greatest part of

Lower case a to z, 12¾ ems

8 POINT OLD STYLE NO 79

THIS BOOKISH INCLINATION at length determined my father to make me a printer, though he had already one son (James) of that profession. In 1717 my brother James returned from England with a press and letters to set up his business in Boston. I liked it much better than that of my father, but still had a hankering for the sea. To prevent the apprehended effect of such an inclination, my father was impatient to have me bound to my brother. I stood out some time, but at last was persuaded, and signed the indentures when I was yet but twelve years old. I was to serve as an apprentice till I was twenty-one years of age, only I was to be allowed journeyman's wages during the last year. In a little time I made great progress in the business, and became a useful hand to my brother. I had now access to better books. An acquaintance with the apprentices of booksellers enabled me sometimes to borrow a small one, which I was careful to return soon, and clean. Often I sat up in my chamber the greatest part of

Lower case a to z, 12½ ems

9 POINT OLD STYLE NO 79

THIS BOOKISH INCLINATION at length determined my father to make me a printer, though he had already one son (James) of that profession. In 1717 my brother James returned from England with a press and letters to set up his business in Boston. I liked it much better than that of my father, but still had a hankering for the sea. To prevent the apprehended effect of such an inclination, my father was impatient to have me bound to my brother. I stood out some time, but at last was persuaded, and signed the indentures when I was yet but twelve years old. I was to serve as an apprentice till I was twenty-one years of age, only I was allowed journeyman's wages

Lower case a to z, 12¼ ems

AMERICAN TYPE FOUNDERS COMPANY

## Franklin Series

10 POINT OLD STYLE NO 79    \*

THIS BOOKISH INCLINATION at length determined my father to make me a printer, though he had already one son (James) of that profession. In 1717 my brother James returned from England with a press and letters to set up his business in Boston. I liked it much better than that of my father, but still had a hankering for the sea. To prevent the apprehended effect of such an inclination, my father was impatient to have me bound to my brother. I stood out some time, but at last was persuaded, and signed the indentures when I was yet but twelve years old. I was to serve as an apprentice till I was twenty-one years of age, only I was to be allowed journeyman's wages during the last year. *In a little time I made great progress in the business, and became a useful hand to my brother. I had now access to better books.*

Lower case a to z, 12 ems

11 POINT OLD STYLE NO 79    \*

THIS BOOKISH INCLINATION at length determined my father to make me a printer, though he had already one son (James) of that profession. In 1717 my brother James returned from England with a press and letters to set up his business in Boston. I liked it much better than that of my father, but still had a hankering for the sea. To prevent the apprehended effect of such an inclination, my father was impatient to have me bound to my brother. I stood out some time, but at last was persuaded, and signed the indentures when *I was yet but twelve years old. I was to serve as an apprentice till I was twenty-one years of age, only I was to be allowed*

Lower case a to z, 12 ems

12 POINT OLD STYLE NO 79    \*

THIS BOOKISH INCLINATION at length determined my father to make me a printer, though he had already one son (James) of that profession. In 1717 my brother James returned from England with a press and letters to set up his business in Boston. I liked it much better than that of my father, but still had a hankering for the sea. To prevent the apprehended effect of such an inclination, my father was impatient to have me bound to my brother. I stood out some time, but at last was persuaded, and signed the indentures when *I was yet but twelve years old. I was to be*

Lower case a to z, 12½ ems

AMERICAN TYPE FOUNDERS COMPANY

## Franklin Series

14 POINT OLD STYLE NO 79 A

20 A 10 A 50 a \$5 21

THIS BOOKISH INCLINATION at length determined my father to make me a printer, though he had already one son (James) of that profession. In 1717 my brother James returned from England with a press and letters to set up his business in Boston. I liked it much better than that of my father, but still had a hankering for the sea. To prevent the apprehended effect of such an inclination, my father was very impatient to have me bound to my brother. I stood out some time, but at last was persuaded, and signed the indentures when I was yet but twelve years old. I was to serve *as an apprentice till I was twenty-one years of age, only I was to be allowed journeyman's*

18 POINT OLD STYLE NO 79 A

12 A 8 A 32 a \$6 50

THIS BOOKISH INCLINATION at length determined my father to make me a printer, though he had already one son (James) of that profession. In 1717 my brother James returned from England with a press and letters to set up his business in Boston. I liked it much better than that of my father but still had a hankering for the sea. To prevent the apprehended effect of such *an inclination, my father was very impatient to have me bound to my brother*

AMERICAN TYPE FOUNDERS COMPANY

## Franklin Series

24 POINT OLD STYLE NO 79 A

12A 6A 26a \$6 95

ITALIC 6A 14a \$3 60

THIS BOOKISH Inclination at length determined my father to make me a printer, though he had one son of that profession. In 1717 my brother returned from England with a press and letters to set up *business in Boston. I liked it much better than that of my*

36 POINT OLD STYLE NO 79 A

6A 4A 14a \$6 79

ITALIC 4A 8a \$4 25

THIS BOOKISH Inclination determined my father to make me a printer, though he *already had one son of that profession. In*

AMERICAN TYPE FOUNDERS COMPANY

6 POINT OLD STYLE No 71 25 A 15 A 170 a \$6 95

On my arrival at Philadelphia I was in my working dress, my best clothes being to come by sea. I was covered with dirt; my pockets were filled with shirts and stockings; I was unacquainted with a single soul in the place, and knew not where to seek lodging. Fatigued with walking, rowing, and having passed the night without sleep, I was extremely hungry, and all my money consisted of a Dutch dollar, and about a shilling's worth of coppers, which I gave to the boatmen for my passage. As I had assisted them in rowing, they refused it at first; but I insisted on their taking it. *A man is sometimes more generous when he has little than when he has much money; probably because, in*

Lower case a to z, 13½ ems

8 POINT OLD STYLE No 71 20A 12 A 120a \$5 40

On my arrival at Philadelphia I was in my working dress, my best clothes being to come by sea. I was covered with dirt; my pockets were filled with shirts and stockings; I was unacquainted with a single soul in the place, and knew not where to seek a lodging. Fatigued with walking, rowing, and having passed the night without sleep, I was extremely hungry, and all my money consisted of a Dutch dollar, and about a shilling's worth

Lower case a to z, 11½ ems

9 POINT OLD STYLE No 71

18A 9A 90a \$4 80

On my arrival at Philadelphia I was in my working dress, my best clothes being to come by sea. I was covered with dirt; my pockets were filled with shirts and stockings; I was unacquainted with a single soul in the place, and knew not where to seek a lodging. Fatigued with walking, rowing, and having passed the night without sleep, I was extremely hungry, and all my money consisted of a Dutch dollar, and about a shilling's worth of coppers, which I gave to the boatmen for my passage. As I had assisted them in rowing, they refused it at first; but I insisted on their taking it. *A man is sometimes more generous when he has little than when he has much money; probably because, in the first case, he is desirous of concealing*

Lower case a to z, 11 2/5 ems

10 POINT OLD STYLE No 71

15A 8A 75a \$4 45

On my arrival at Philadelphia I was in my working dress, my best clothes being to come by sea. I was covered with dirt; my pockets were filled with shirts and stockings; I was unacquainted with a single soul in the place, and knew not where to seek lodging. Fatigued with walking, rowing, and having passed the night without sleep, I was extremely hungry, and all my money consisted of a Dutch dollar, and about a shilling's worth of coppers, which I gave to the boatmen for my passage. *As I had assisted them in rowing, they refused it at first; but I insisted on their taking it. A man is sometimes more*

Lower case a to z, 11¼ ems

11 POINT OLD STYLE No 71

14A 7A 70a \$4 20

On my arrival at Philadelphia I was in my working dress, my best clothes being to come by sea. I was covered with dirt; my pockets were filled with shirts and stockings; I was unacquainted with a single soul in the place, and knew not where to seek a lodging. Fatigued with walking, rowing, and having passed the night without sleep, I was extremely hungry, and all my money consisted of a Dutch dollar, and about a shilling's worth of coppers, which I gave to the boatmen for my passage. *As I had*

Lower case a to z, 11¼ ems

AMERICAN TYPE FOUNDERS COMPANY



12 POINT OLD STYLE No 71

12 A 6 A 60 a \$4 60

ON my arrival at Philadelphia I was in my working dress, my best clothes being to come by sea. I was covered with dirt; my pockets were filled with shirts and stockings; I was unacquainted with a single soul in the place, and knew not where to seek a lodging. Fatigued with walking, rowing, and having passed the night without sleep, I was extremely hungry, and all my money consisted of a Dutch dollar, and about a shilling's worth of coppers, which I gave to the boatmen for my passage. *As I had assisted them in rowing, they refused it at first; but I insisted on their taking it.*

Lower case a to z, 11 5-6 ems

14 POINT OLD STYLE No 71

16 A 14 A 52 a \$5 25

ON my arrival at Philadelphia I was in my working dress, my best clothes being to come by sea. I was covered with dirt; my pockets were filled with shirts and stockings; I was unacquainted with a single soul in the place, and knew not where to seek a lodging. Fatigued with walking, rowing, and having passed the night without sleep, *I was extremely hungry, and all my money consisted of a Dutch dollar, and about a shilling's worth*

16 POINT OLD STYLE No 71

18 A 14 A 52 a \$8 30

ON my arrival at Philadelphia I was in my working dress, my best clothes being to come by sea. I was covered with dirt; my pockets were filled with shirts and stockings; I was unacquainted with *a single soul in the place, and knew not where to seek lodging. Fatigued with walk*

**Caslon Old Style No 71**

22 POINT

14 A 10 A 28 a \$7 65

24 POINT

10 A 7 A 20 a \$7 65

AQUATIC Pastime | Ancient BARDS

28 POINT

7 A 4 A 14 a \$8 95

American HOME COMFORT

36 POINT

7 A 4 A 14 a \$9 35

FINE GARDEN Scene

40 POINT

5 A 10 a \$8 35

OCEAN Currents

48 POINT

4 A 6 a \$8 50

Evening SONG

80 POINT

3 A 4 a \$10 45

SIR Knight

72 POINT

3 A 3 a \$14 05

Rich Bets

AMERICAN TYPE FOUNDERS COMPANY

**Caslon Old Style Italic No 71**

14 POINT

18 A 52 a \$5 00

*INCREDIBLE Adventures of Monsieur Jack Robinson*

18 POINT

10 A 28 a \$3 40

*Agricultural and Industrial ENTERPRISES*

22 POINT

8 A 18 a \$3 15

*DEXTEROUS Artisans and Laborers*

24 POINT

6 A 14 a \$3 35

*Midsummer Exhibition of FRUITS*

28 POINT

5 A 10 a \$3 80

*GIFTS for the Grandchildren*

36 POINT

4 A 8 a \$4 60

*Polar Skating RINK*

40 POINT

4 A 7 a \$5 15

*ROCKY Ramblings*

48 POINT

3 A 5 a \$6 05

*Printing HOUSE*

AMERICAN TYPE FOUNDERS COMPANY

## French Old Style No 2

6 POINT

30 A \$1 25 30 A 20 A 100 a \$4 00

### PRECEPTS IMPARTED TO THE MASTER AS WELL AS THE APPRENTICE

#### LECTURE ON THOROUGHNESS

Thoroughness in printing offices is an accomplishment that is often neglected by those who are learning and by those who are practicing the principles contained in our high and noble calling. While it is true that much is left to the taste and judgment of the workman, and much of his success depends upon the cultivation of taste and exercise of judgment, it is also true that there are numerous important fixed rules and principles that no sensible printer will care to ignore; and if he does run counter to them he does so at his own risk, and in the end will be more harmed than benefited by his own stubbornness or ignorance. Most printers, who set themselves up as original and artistic printers, are original botches, and they continue to hold their own through life, or until some accident or combination of circumstances forces them to see their weakness, when, if they are not too proud and conceited, they may, by patient industry and perseverance, hope to become workmen of ordinary ability, and spend the remainder of their days in quiet usefulness. Artistic workmen are few indeed. If a person has enough artistic ability to be able at all times to create forms of beauty and symmetry that will be the wonder of his less fortunate neighbors, he can always find employment more remunerative. "Whatever is worth doing at all, is worth doing well," is a maxim that few follow because many do not know how. Cheap Printing may serve a cheap man, but

Lower case a to z, 14 ems

7 POINT

30 A \$1 60 30 A 15 A 90 a \$4 60

### SOME ANNOYING HABITS POSSESSED BY THE SLOUCHY PRINTER

#### COMMENT ON THE SLOUCH

A number of interesting experiments are performed by compositors in the several processes of setting, correcting and distributing type, that may be justly classified outside the pale of typographic tolerance. As long as the offender is unnoticed or not discovered in his mean habits, just so long will he continue to exercise them. These practices, as we all know, are confined only to the more incompetent, or to the workman who is intentionally slovenly. They mark his course at every turn in the office, and require little investigation to establish their rightful originator. What a source of annoyance it is to the careful man to lift a handful of matter for distribution and find it plentifully interlarded with bent spaces. This is the lazy man or slouch graphically illustrated. A bent space might accidentally occur in the matter, and such a fact might happen more than once and be forgiven; but where the premeditated reminder of so much careless and slouchy spacing comes into the hands of careful printers who use their best

Lower case a to z, 14½ ems

8 POINT

30 A \$1 65 30 A 15 A 90 a \$4 60

### THE EVILS THAT BESET THE PRINTERS WHO GET LOW PRICES LOW-PRICED JOB WORK

It has been said that there is less profit in the printing business, for the amount of capital invested and the amount of energy required, than in most other lines of business. There is considerable truth in this without a doubt; though, in a great measure the fact of its possessing any truth is more attributable to the loose methods that some printers resort to, than to anything essentially necessary to and in fact forming a part of the business itself. It is due to abuses which have grown up within the business, and are tolerated by those engaged in it, that it has become unprofitable. Take, for instance, the system of daily soliciting of estimates as practiced by stationers everywhere. Many people, through convenience or friendship, give their orders for printing to their stationers. Use printers' ink applied by me, and you will never meet the sheriff with a red flag.

Lower case a to z, 13¾ ems

AMERICAN TYPE FOUNDERS COMPANY

## French Old Style No 2

10 POINT

24 A \$1 80 24 A 12 A 75 a \$4 70

### A CLASS OF MEN WHO NEED ALL THE CUFFS THEY GET SCORING THE PRINTER

Does the printer read up in his profession as thoroughly as he should? I should say not. It is a deplorable fact, but nevertheless true, that, as a class, the printers of this country do not keep read up on the subject of printing to any extent. Where you find one that does, you will find a dozen that do not. In this day every office in the land is kept supplied with all manner of craft journals, specimen sheets of late faces, and numberless circulars describing new inventions and novelties made for the use of the printer; yet but very few avail themselves of these opportunities to extend their knowledge of the art that gains them a living. More offices than one in the country have dozens of printers in their employ not one of whom ever reads a craft publication. These men work day after day, simply following furrow after furrow, like a horse dragging a plow, with no object before them except longing for dinner-time or supper-time, or Sunday. And yet these men are to be called printers. Two small heads are better than one "big head" in the work shop.

Lower case a to z, 12 $\frac{2}{3}$  ems

12 POINT

20 A \$1 55 20 A 10 A 60 a \$5 00

### MUSCULAR GENTLEMEN EXHIBIT ENDURANCE CONSTITUTIONAL AMENDMENTS

Health is the soul that animates all enjoyments of life, which fade, and are tasteless, if not dead, without it. Man starves at the best and the greatest tables, makes faces at the most delicate wines, is old and impotent in seraglios of the most sparkling beauties, is poor and wretched in the midst of the greatest treasures; with diseases, strength grows decrepit, youth loses vigor and beauty charms; music grows harsh; palaces are prisons, or of equal confinement; conversation disagreeable; riches are useless, honors and attendance are cumbersome, and crowns themselves are a burden. But if diseases are painful and violent they equal all conditions of life, make no difference between a prince and a pauper. Procrastination is the Thief of Profits.

Lower case a to z, 13 ems

AMERICAN TYPE FOUNDERS COMPANY

## French Old Style No 2

18 POINT

18 A \$2 50 18 A 38 a \$5 00

# CONSOLIDATED RAILROAD

Manufacturing and Refrigerator Companies  
Large Dividends Declared

20 POINT

14 A \$2 70 14 A 28 a \$5 50

# MIDNIGHT PHANTOMS

National Humane Society Station  
Desire Prompt Service

24 POINT

10 A \$2 80 10 A 20 a \$5 75

# EMBELLISHMENT

White Marble Monuments  
Recommended

30 POINT

7 A \$2 90 7 A 12 a \$5 75

# MANUFACTURE

Everlasting Ornaments  
China Pitchers

AMERICAN TYPE FOUNDERS COMPANY

French Old Style No 2

36 POINT

5 A \$3 00 5 A 9 a \$6 00

PUBLISHED  
Gigantic Elephant

48 POINT

4 A \$4 50 4 A 7 a \$6 50

BANKING  
Other Horses

60 POINT

4 A \$7 60 4 A 5 a \$12 00

Democrats

72 POINT

3 A \$6 40 3 A 4 a \$14 00

Advocate

AMERICAN TYPE FOUNDERS COMPANY

## French Old Style No 2 Italic

*This Italic lines with French Old Style No. 2. Italic of same face, to line with French Elzevir, supplied at prices listed on page 69*

6 POINT

20 A 45 a \$2 25

### TO THE MESSIEURS ELZEVR

*I am indebted to you, and more so, perhaps, than you imagine. The honor of Roman citizenship is even less than the benefit you have conferred on me. For what do you think was this honor in comparison with that of being placed in the ranks with your authors? It is to rank with the consuls and senators of Rome: it is to be made fel 1234567890*

7 POINT

24 A 60 a \$2 50

### TO MESSIEURS ELZEVR

*I am indebted to you, and more so, perhaps, than you imagine. The honor of Roman citizenship is less than the benefit you have conferred on me. For what do you think was this honor in comparison with that of being placed in 1234567890*

8 POINT

24 A 60 a \$2 75

### TO THE MESSIEURS ELZEVR

*I am indebted to you, and more so, perhaps, than you imagine. The honor of Roman citizenship is even less than the benefit you have conferred on me. For what do you think was this honor in comparison with that of being placed in the ranks with your authors? It is to rank with the consuls and senators of Rome: it is to be made fellow with the Sallusts and Ciceros? What glory it is to say, I am a member of this immortal republic: I have been received 1234567890*

10 POINT

20 A 50 a \$3 00

### TO THE MESSIEURS ELZEVR

*I am indebted to you, and more so, perhaps, than you imagine. The honor of Roman citizenship is even less than the benefit you have conferred on me. For what do you think was this honor in comparison with that of being placed in the ranks with your authors? It is to rank with the consuls and senators of Rome; it is to be made fell 1234567890*

12 POINT

16 A 40 a \$3 50

### TO THE MESSIEURS ELZEVR

*I am indebted to you, and more so, perhaps, than you imagine. The honor of Roman citizenship is even less than the benefit you have conferred on me. For what do you think was this honor in comparison with that of being 1234567890*

14 POINT ELZEVR ITALIC A

16 A 36 a \$3 90

### TO THE MESSIEURS ELZEVR

*I am indebted to you, and more so, perhaps, than you may imagine. The honor of Roman citizenship is even less than the benefit you have co 1234567890*

AMERICAN TYPE FOUNDERS COMPANY



## French Elzevir No 1

8 POINT

ITALIO 28 A 80 a \$3 00 40 A 20 A 90 a \$4 00

A COMPOSITOR, unless he is a natural genius, should spend long years in study and patient practice, cultivating his taste and strengthening his judgment, before he enters far into the domain of original designing, if he wishes to give better satisfaction to his employers and to the customers of his employers. New beginners often bring forth new designs, never known before and which no one would probably ever wish to see again, at a marvellous speed. But in this, as in everything else, the farther they advance the more careful they are of their opinions and ideas as authority for those whom they consider their inferiors in all

Lower case a to z, 12¼ ems

AN ORIGINAL PIECE OF COMPOSITION A PRODUCTION NOT PERCEIVED

1 2 3 4 5 6 7 8 9 0

10 POINT

ITALIO 28 A 80 a \$3 80 40 A 20 A 80 a \$4 75

IT IS an evidence of a growing desire on the part of those interested in printing to see it more worthily filling the exalted position for which it was surely destined. But when we take into consideration the long line of years throughout which our craft has suffered the depleting influences of those who have gone into it to make money, and that quickly, we must be prepared for a somewhat arduous task in our endeavor to right it again. (It is hardly likely

Lower case a to z, 12 ems

ONLY SUCCEEDS IN SHOWING HIS IGNORANCE

12 POINT

ITALIO 20 A 50 a \$3 94 28 A 18 A 82 a \$5 00

SO MUCH has been said about artistic printing that, at the first blush, one would naturally come to the conclusion that all that could be said had been said. Yet it is not so. We can scarcely open a trade organ without seeing something, either good, bad or indifferent, on the subject. In fact our daily and weekly

Lower case a to z, 12½ ems

A CHAPTER ON ARTISTIC PRINTING

14 POINT

ITALIO 18 A 36 a \$3 90 20 A 10 A 50 a \$5 00

On my arrival at Philadelphia I was in my working dress, my best clothes being to come by sea. I was covered with dirt; my pockets were filled with shirts and stockings; I was unacquainted with a single soul

EXTENSIVE CHICAGO PUBLISHERS

AMERICAN TYPE FOUNDERS COMPANY

# Cushing Series

PATENTED

6 POINT

20 A 12 A 50 a \$3 50

EXPERIENCE PROVES that the apprentice foreshadows the workman, just as surely as the bend of the twig foretells the inclination of the tree. The *upright, obedient, industrious lad* will graduate a steady, skilful, and capable man, as unmistakably as the perverse, idling, careless boy will ripen into a lazy, dissolute fellow. The fact is, a boy is measurably the maker of his own destiny; and if he fails to acquire a master-knowledge of the trade to which he is put, it will mainly be because he did not at his outset determine to be a master-workman. Good morals and steady industry are indispensable. When a lad who possesses these qualities proposes to learn the art and mystery of printing, it should be inquired of him, Has he had

1234567890

ABCDEFGHIJKLM

ABCDEFGHIJKLMNOP

6 POINT

20 A 12 A 44 a \$4 00

EXPERIENCE PROVES that the apprentice foreshadows the workman, just as surely as the bend of the twig foretells the inclination of the tree. The *upright, obedient, industrious lad* will graduate a steady, skilful, and capable man, as unmistakably as the perverse, idling, careless boy will ripen into a lazy, dissolute fellow. The fact is, a boy is measurably the maker of his own destiny; and if he fails to acquire a master-knowledge of the trade to which he is put,

1234567890

ABCDEFGHIJK

ABCDEFGHIJKLMNO

10 POINT

16 A 10 A 40 a \$4 50

EXPERIENCE PROVES that the apprentice foreshadows the workman, just as surely as the bend of the twig foretells the inclination of the tree. The *upright, obedient, industrious lad* will graduate a steady, skilful, and capable man, as unmistakably as the perverse, idling, careless boy will ripen into a lazy, dissolute fellow. The fact is, a boy is measurably the maker of his own destiny; and if he fails to acquire a master-knowledge of the trade to which he is put, it will mainly be because he did not at his outset determine to be a master-workman. Good morals and steady industry are indispensable. When a lad who possesses these qualities proposes to learn the art and mystery of printing,

1234567890

ABCDEFGHIJKLMNQPORS

ABCDEFGHIJKLMNQPQRSTUVWXYZ

12 POINT

14 A 8 A 36 a \$5 00

EXPERIENCE PROVES that the apprentice foreshadows the workman, just as surely as the bend of the twig foretells the inclination of the tree. The *upright, obedient, industrious lad* will graduate a steady, skilful, and capable man, as unmistakably as the perverse, idling, careless boy will ripen into a lazy, dissolute fellow. The fact is, a boy is measurably the maker of his own destiny; and if he fails to acquire a master-knowledge

1234567890

ABCDEFGHIJKLMNOP

ABCDEFGHIJKLMNQPQRSTUVWXYZ

*Sold in 25 and 50 lb. fonts and upward at prices of Roman body type*

AMERICAN TYPE FOUNDERS COMPANY

# Cushing Italic

PATENTED

6 POINT

28 A 80 a \$2 80

*The fawn of the wind of the spring is shy,  
Her light feet rustle sere and white grass,  
The trees are roused as she races by,  
In the pattering roin we hear her pass;  
And the bow unstrung we cast aside,  
While we winnow the golden, hoarded maize,  
And the earth awakes with a thrill of pride  
To deck her beauty for festal days.*

*All who are familiar with historical researches know that often the discovery of a new fact, far from aiding in the solution of a perplexing problem, only makes it harder to solve by involving it in deeper obscurity. Thus it has been in regard to the origin of printing. These facts of absolute authenticity, however, found in the records of the notaries of Avignon by M. Requin and published recently in the Chron. 1234567890*

THE EARLIEST EUROPEAN PRINTERS

8 POINT

28 A 80 a \$3 00

*All who are familiar with historical researches know that often the discovery of a new fact, far from aiding in the solution of a perplexing problem, only makes it harder to solve by involving it in deeper obscurity. Thus it has been in regard to the origin of printing. These facts of absolute authenticity, however, found in the records of the notaries of Avignon by M. Requin and published recently in the Chronicle of the General Journal of Printing, show plainly that the mystery surrounding the early printers is being somewhat dissipated. An examination of them proves that a man named Waldfoghel, of Prague, early in the year 1444, established a printing office at Avignon, and there trained his apprentices "in the art of artificial writing." This 1234567890*

THE EARLIEST EUROPEAN PRINTERS

10 POINT

28 A 80 a \$3 80

*All who are familiar with historical researches know that often the discovery of a new fact, far from aiding in the solution of a perplexing problem, only makes it harder to solve by involving it in deeper obscurity. Thus it has been in regard to the origin of printing. These facts of absolute authenticity, however, found in the records of the notaries of Avignon by M. Requin and published recently in the Chronicle of the General Journal of Printing, show plainly that the mystery surrounding the early printers is being somewhat dissipated. An ex 12345678*

THE EARLIEST EUROPEAN PRINTERS

12 POINT

20 A 50 a \$3 94

*All who are familiar with historical researches know that often the discovery of a new fact, far from aiding in the solution of a perplexing problem, only makes it harder to solve by involving it in deeper obscurity. Thus it has been in regard to the origin of printing. These facts of absolute authenticity, however, found in the records of the notaries of Avignon by M. Requin and 12345678*

EARLIEST EUROPEAN PRINTERS

AMERICAN TYPE FOUNDERS COMPANY

## Cushing Monotone

11 POINT

25 and 50 pounds and upwards, 44 cents per pound

The poetical temperament of Columbus is discernible throughout his writings, and in all his actions. It spread a golden and glorious world around him, and tinged everything with its own gorgeous colors. It betrayed him into visionary speculations, which subjected him to the sneers and cavilings of men of cooler and safer but more 12345678

### THE SUPERIOR CHARACTER OF COLUMBUS

10 POINT

25 and 50 pounds and upwards, 46 cents per pound

**T**HE poetical temperament of Columbus is discernible throughout his writings, and in all his actions. It spread a golden and glorious world around him, and tinged everything with its own gorgeous colors. It betrayed him into visionary speculations, which subjected him to the sneers 123

CHRISTOPHER  
COLUMBUS, A NATIVE  
OF GENOA

COMPARATIVE  
ACUTENESS OR OBTUSE-  
NESS OF ITS  
POWERS

8 POINT

25 and 50 pounds and upwards, 52 cents per pound

**T**HE faculty of memory, which receives and retains ideas and images, and which exhibits them again with or without the exercise of volition, early became the subject of philosophical research. There are very many curious phenomena connected with this power of the mind; it is sometimes as recreant to its trust, when most its service may be required, as the veriest bankrupt; at other times, when in a fit of strange caprice, it will obtrude upon us in a most 1234

10 POINT NO 2

25 and 50 pounds and upwards, 46 cents per pound

The faculty of memory, which receives and retains ideas and images, and which exhibits them again with or without the exercise of volition, early became the subject of philosophical research. There are very many curious phenomena connected with this power of the mind; it is sometimes as recreant to its trust, when most its service may be required, as the veriest bankrupt; at other times, 123456789

MEMORY IS INDISPENSABLE TO MORAL ECONOMY

AMERICAN TYPE FOUNDERS COMPANY

# Ronaldson Series

8 POINT OLD STYLE NO 72

JAMES RONALDSON, the son of William Ronaldson, was born 1768, at Gorgie, near Edinburgh, and died in the city of Philadelphia in 1842. In 1794 he arrived at Philadelphia, aboard the sailing-vessel Providence. Shortly after his arrival he renewed his acquaintance with Archibald Binny, whom he had formerly met when living in Scotland. For a year or two after his arrival in this country Ronaldson carried on a biscuit bakery. His establishment was destroyed by fire in 1796, so that he found himself out of an occupation. It is related that about this time he encountered Binny in an ale-house; their acquaintance ripened into a friendly intimacy, and they soon learned each other's views and prospects. The result was that a copartnership was formed between them, beginning Nov. 1, 1796, establishing the first permanent type-foundry in this country. Ronaldson contributed the greater portion of the capital, and took charge of the financial part of the enterprise. *Binny, who was a practical type-founder, and at one time had carried on the business at Edinburgh,*

contributed his tools, stock of metal, and types, and assumed control of the mechanical department. The connection proved advantageous to each party, and a prosperous business was the result. American printers, who had up to this time relied on British founders for their type, patronized the new establishment, and, to quote the words of Ronaldson, "the importation of foreign type ceased in proportion as Binny & Ronaldson became known to the printers of the United States." The type-founding tools and material, which Benjamin Franklin had brought with him from France for his own convenience in casting sorts, came into possession of the firm in 1806. After Dr. Franklin's death, they became the property of Mr. Duane, a relative of the philosopher, who, justly appreciating the true ardor with which Messrs. Binny & Ronaldson endeavored to succeed, offered them the loan of these tools. After an examination of them by Ronaldson, he *was so much pleased with the superiority of a number of them over their own, and fearing that Mr. Duane might change his*

ABCDEFGHIJKLMNPOQRSTUVWXYZ

12345

Lower case a to z, 15¼ ems

67890

7 POINT OLD STYLE NO 72

JAMES RONALDSON, a son of William Ronaldson, was born in the year 1768, at Gorgie, near Edinburgh, and died in Philadelphia in 1842. In 1794 he came to Philadelphia in the sailing-vessel Providence. Shortly after his arrival he renewed his acquaintance with Mr. Archibald Binny, whom he had previously known in Scotland. For a year or two after his arrival in this country Ronaldson carried on a biscuit bakery. His establishment was destroyed by fire in 1796, so that he found himself without occupation. It is related that about this time he encountered Binny in an ale-house; their acquaintance soon ripened into a friendly intimacy, and they early learned each other's prospects and views. The result was the formation of a copartnership, beginning Nov. 1, 1796, establishing the first permanent type-foundry in this country. *Mr. Ronaldson contributed the greater portion of the capital, and assumed*

control of the financial branch of the business. Binny, who was a practical type-founder, and had carried on the business in Edinburgh, contributed his tools, stock of metal, and types, and superintended the mechanical department. The connection proved mutually advantageous, and resulted in a prosperous business. American printers, who had hitherto relied on British founders for their supply of type, patronized the new concern, and, in Mr. Ronaldson's words, "the importation of foreign type ceased in proportion as Binny & Ronaldson became known to the printers of the United States." In 1806, the type-founding tools and materials, which Dr. Benjamin Franklin had brought from France for his own convenience in casting sorts, came into possession of the said firm. After Dr. Franklin's death, they became the property of Mr. Duane, who was a near relative of the philosopher, who, appreciating

ABCDEFGHIJKLMNPOQRSTUVWXYZ

12345

Lower case a to z, 14¾ ems

67890

AMERICAN TYPE FOUNDERS COMPANY

## Ronaldson Series

8 POINT OLD STYLE No 72

JAMES RONALDSON, the son of William Ronaldson, was born in 1768, at Gorgie, near Edinburgh, and died in Philadelphia in 1842. In 1794 he came to Philadelphia in the sailing-vessel Providence. A short time after his arrival he renewed his acquaintance with Archibald Binny, whom he had previously known in Scotland. For a year or two after his arrival in this country Ronaldson carried on a biscuit bakery. His establishment was destroyed by fire in 1796, so that he found himself out of an occupation. It is related that about this time he encountered Binny in an ale-house; their acquaintance ripened into a friendly intimacy, and they soon learned each other's views and prospects. The natural result was the formation of a copartnership between them, beginning November 1, 1796, establishing the first permanent type-foundry in the United States. Ronaldson furnished the greater portion of the capital, and assumed control of the financial branch of the business. Binny, who was a practical type-founder, and had carried on the business in Edinburgh, contributed his tools, stock of metal, and types, and superintended the manufacturing department. The connection proved mutually advantageous, and a most prosperous business was the result. American printers, who had hitherto relied on the British founders for their supply of type, patronized the *new establishment, and, in the words of Ronaldson, "the importation of foreign type ceased in proportion as Binny & Ronaldson became known to the printers of the United States."* During 1806 the type-

Lower case a to z, 14 ems

ABCDEFGHIJKLMNOPQRSTUVWXYZ

1234567890

9 POINT OLD STYLE No 72

JAMES RONALDSON, son of William Ronaldson, was born in 1768, at Gorgie, near Edinburgh, and died in the city of Philadelphia in 1842. In 1794 he came to Philadelphia in the sailing-vessel Providence. Shortly after his arrival he renewed his acquaintance with Archibald Binny, whom he had previously known while in Scotland. For a year or two after his arrival in this country Ronaldson carried on a biscuit bakery. His establishment was totally destroyed by fire in 1796, so that he found himself out of an occupation. It is related that about this time he encountered Binny in an ale-house; their acquaintance ripened into a most friendly intimacy, and they soon learned each other's intentions and prospects. The natural result of this was the formation of a copartnership between them, beginning November 1, 1796, establishing the first permanent type-foundry in the United States. Ronaldson furnished the greater portion of the capital invested, and assumed control of the financial branch of the business. Binny, who was a practical type-founder, and had carried on the business in *Edinburgh, contributed his tools, stock of metal, and types, and superintended the manufacturing department. The connection proved mutually advantageous, and a prosperous business was the result*

Lower case a to z, 13½ ems

ABCDEFGHIJKLMNOPQRSTUVWXYZ

1234567890

AMERICAN TYPE FOUNDERS COMPANY

## Ronaldson Series

10 POINT OLD STYLE No 72

JAMES RONALDSON, the son of William Ronaldson, was born in 1768, at Gorgie, near Edinburgh, and died in Philadelphia in the year 1842. In 1794 he came to Philadelphia, aboard the sailing-vessel Providence. Shortly after his arrival he renewed his acquaintance with Archibald Binny, whom he had previously known when living in Scotland. For a year or two after his arrival in this country Ronaldson carried on a biscuit bakery. His establishment was destroyed by fire in 1796, so that he found himself deprived of an occupation. It is related that about this time he encountered Binny in an ale-house; their acquaintance ripened into a most friendly intimacy, and they soon learned each other's views and prospects. The natural result was a copartnership between them, beginning Nov. 1, 1796, establishing the first permanent type-foundry in the United States. *Ronaldson, who furnished the greater portion of the capital, assumed control of the financial part of the business. Binny, who was a practical type-founder*

Lower case a to z, 13 ems

ABCDEFGHIJKLMNOPQRSTUVWXYZ

1 2 3 4 5 6 7 8 9 0

11 POINT OLD STYLE No 72

JAMES RONALDSON, the son of William Ronaldson, was born in 1768, at Gorgie, near Edinburgh, and died in Philadelphia in 1842. In 1794 he came to Philadelphia, aboard the sailing-vessel Providence. Shortly after his arrival he renewed his intimacy with Archibald Binny, with whom he was on friendly terms when in Scotland. For a year or two after his arrival in this country Ronaldson carried on a biscuit bakery. His establishment was destroyed by fire in 1796, so that he found himself out of an occupation. It is related that about this time he encountered Binny in an ale-house; their acquaintance ripened into a friendly intimacy, and they shortly learned each other's views and prospects. The natural result was a copartnership between them, beginning Nov. 1, 1796, establishing the first permanent type-foundry in the United States. *Ronaldson, who furnished the greater*

Lower case a to z, 12½ ems

ABCDEFGHIJKLMNOPQRSTUVWXYZ

1 2 3 4 5 6 7 8 9 0

AMERICAN TYPE FOUNDERS COMPANY

## Ronaldson Series

12 POINT OLD STYLE NO 72

JAMES RONALDSON, the son of William Ronaldson, was born in 1768, at Gorgie, near Edinburgh, and died in Philadelphia in 1842. In 1794 he arrived at Philadelphia in the sailing-vessel Providence. Shortly after his arrival he renewed his acquaintance with Archibald Binny, whom he had formerly known when living in Scotland. For a year or two after his arrival in this country Ronaldson carried on a biscuit bakery. His establishment was destroyed by fire in 1796; by this disaster he found himself out of an occupation. It is related that about this time he encountered Binny in an ale-house; their acquaintance ripened into a friendly intimacy, and they soon learned each other's views and prospects. *The natural result was a copartnership was formed*

ABCDEFGHIJKLMNOPQRSTUVWXYZ

I 2 3 4 5

Lower case a to z, 12½ ems

6 7 8 9 0

15 POINT OLD STYLE NO 72

JAMES RONALDSON, the son of William Ronaldson, was born in 1768, at Gorgie, near Edinburgh, and died in Philadelphia in 1842. In 1794 he arrived at the city of Philadelphia in the sailing-vessel Providence. A short time after his arrival he renewed his acquaintance with Archibald Binny, whom he had previously known when living in Scotland. For a year or two after his arrival in the United States Ronaldson carried on a biscuit bakery at

ABCDEFGHIJKLMNQRST

I 2 3 4 5

Lower case a to z, 12½ ems

6 7 8 9 0

AMERICAN TYPE FOUNDERS COMPANY



## Ronaldson Series

18 POINT OLD STYLE NO 72

14A 30a \$4 30

### SHREWD BUSINESS ENTERPRISE

James Ronaldson, the son of William Ronaldson, was born in 1768, at Gorgie, near Edinburgh, and died in the City of Philadelphia in 1842. He came to Philadelphia in 1794 in the sailing-vessel Providence. A short time after his arrival he renewed his acquaintance with Archibald Binny, whom he had formerly known when living in Scotland. For a year or two after his arrival in this country Ronaldson carried on a biscuit bakery. His establishment

24 POINT OLD STYLE NO 72

10A 20a \$4 70

### UNWEARIED MERCHANT

James Ronaldson arrived in this country in the year 1794. After this he renewed his acquaintance with Archibald Binny, whom he had formerly known when living in Scotland. For a year or two Ronaldson carried on a bakery.

Ronaldson Series

30 POINT OLD STYLE NO 72

8 A 16 a \$5 85

FACING WESTWARD

James Ronaldson came to this country in the sailing-vessel Providence, in 1794.

36 POINT OLD STYLE NO 72

6 A 12 a \$7 00

KINDRED FATHER

James Ronaldson was born in 1768, and died

48 POINT OLD STYLE NO 72

5 A 8 a \$8 00

ESTABLISHED

James Ronaldson of Scotland, came

AMERICAN TYPE FOUNDERS COMPANY

**Ronaldson Condensed**

48 POINT

5 A 8 a \$5 90

**SOBER Minded GIRL**

38 POINT

7 A 12 a \$5 25

**Eastern PATROL Stations**

30 POINT

8 A 14 a \$4 15

**IMPORTANT PERSON  
Mediocrity's Dictatorial Bearing**

24 POINT

10 A 18 a \$3 60

**PROTESTS  
Crossing Bayonets**

18 POINT

14 A 28 a \$3 15

**RESTORATION  
Luxuries of Relaxation**

12 POINT

22 A 45 a \$2 70

**YOUTHFUL LOVERS  
Treading on Enchanted Ground  
Dream of Fairyland**

10 POINT

26 A 52 a \$2 55

**INTIMIDATE & TERRIFY  
Ghost Story and Scarecrow Dealers  
Improved Burglar Alarm**

8 POINT

30 A 80 a \$2 50

**SCIENTIFIC INCONGRUITY  
Cherished Theories Relentlessly Exploded  
Centuries of Implicit Credence**

8 POINT

38 A 70 a \$2 50

**EXCELLENCE IN WORKMANSHIP  
Trustworthy Dealing with the World and his Wife  
Untainted by Equivocation**

1 2 3 4 5 6 7 8 9 0

1 2 3 4 5 6 7 8 9 0

**AMERICAN TYPE FOUNDERS COMPANY**

48 POINT

4 A 8 a \$8 45

NINE More

36 POINT

5 A 8 a \$6 55

Truck PATCH

30 POINT

8 A 10 a \$5 40

STATED  
National Returns

24 POINT

8 A 12 a \$4 85

WAVE  
Departing

18 POINT

10 A 18 a \$4 00

BRIGHT  
Dainty Child

12 POINT

18 A 28 a \$3 50

MINUTES  
Dramatic Society  
Elocutionists

10 POINT

20 A 30 a \$3 00

AMBITIOUS  
Energetic Schoolboy  
Pushing Ahead

8 POINT

22 A 32 a \$2 70

MUNCHAUSEN  
Writer of Circus Posters  
Medical Certificates  
1234567890

8 POINT

25 A 40 a \$2 45

SUMMER VERDURE  
Smiling Rainbow'd Meadows  
Drooping Blossoms  
1234567890

38 POINT

5 A 8 a \$8 00

**CHILD** *Spankers*

30 POINT

6 A 10 a \$5 25

**GRUMBLING**  
*Jawtickler Curatives*

24 POINT

8 A 14 a \$4 50

**TEXAN STEERS**  
*Cowboy Lassos Electrified*

18 POINT

12 A 22 a \$4 15

**POCKET BATTERY**  
*Thoroughly Paralyzes Pickpockets*

12 POINT

20 A 40 a \$3 55

**ELECTRIC**  
*Burglar Alarm Hinges*  
*For Chicken Coops*

10 POINT

22 A 45 a \$3 35

**RAPID TRANSIT**  
*Fleeting Landscape Scene*  
*Passing Glimpse*

8 POINT

25 A 50 a \$3 15

**CRIME PUNISHED**  
*Appliances to Produce Torture*  
*Suitable to the Offense*  
1 2 3 4 5 6 7 8 9 0

6 POINT

30 A 80 a \$3 00

**DYNAMO & COMPANY**  
*Contrivers of Electrical Machinery*  
*Adapted to Various Purposes*  
1 2 3 4 5 6 7 8 9 0

48 POINT

5 A 8 a \$8 35

# Rubber SHOES

38 POINT

8 A 10 a \$7 00

# HONEST Merchant

30 POINT

8 A 18 a \$8 05

# STARVATION Stoppage for Luncheon

24 POINT

10 A 20 a \$5 00

# SUGAR Maple Region

18 POINT

14 A 28 a \$4 65

# WEDDINGS Joyous Occasions

12 POINT

22 A 45 a \$3 95

# REFORMATION Honest Officials Accept Public Trusts

10 POINT

25 A 50 a \$3 55

# EXAMINATIONS Application Blanks Mailed Gratuitously

8 POINT

30 A 80 a \$3 45

# POLITICAL PROBLEM Discovering Methods to Secure Rapid Postal Service 1 2 3 4 5 6 7 8 9 0

8 POINT

36 A 70 a \$3 35

# EXPOSTULATING CITIZENS Freeholders and Taxpayers Combined Grand Mass Meeting 1 2 3 4 5 6 7 8 9 0

**Ronaldson Gothic**

48 POINT

5 A 7 a \$7 15

**Pleasant DREAM**

36 POINT

6 A 9 a \$5 80

**Sugar CANDY Gratis**

30 POINT

8 A 12 a \$4 95

**OLDENTIME Observance**

24 POINT

10 A 15 a \$3 70

**Splendid PRESENTS Displayed**

18 POINT

12 A 18 a \$3 15

**OVERFLOWING  
Family Blessings**

14 POINT

18 A 28 a \$3 15

**REMEMBERING  
Mannerly Younkers**

12 POINT

22 A 34 a \$3 10

**AFTER DINNER  
Boisterous Enjoyment  
Shared by Adults**

10 POINT

28 A 45 a \$3 10

**MODEST MAIDENS  
Courteous and Polite Girls  
Womanhood Adored**

8 POINT

38 A 55 a \$3 10

**KRISS KRINGLE ANTICS  
Wriggling Down Narrow Chimneys  
1 2 3 4 5 6 7 8 9 0**

6 POINT

40 A 60 a \$3 10

**WELCOME AS SPRINGTIME  
Opportunities to Please the Children  
1 2 3 4 5 6 7 8 9 0**

36 POINT

4 A 7 a \$6 85

**DYNAMO**  
**Great Progress**

30 POINT

6 A 9 a \$6 25

**ELECTRIC**  
**Lighting Triumph**

24 POINT

8 A 12 a \$5 50

**ASTRONOMER**  
**Heavenly Observation**

18 POINT

12 A 22 a \$5 25

**MODERN WONDER**  
**Musical Selections Repeated**  
**Automatically**

14 POINT

18 A 30 a \$5 00

**STRIKING LIKENESS**  
**Instantaneous Photograph Produced**  
**Sunshine Necessary**



Old Style Title

---

12 POINT

22 A 32 a \$4 95

**ANTE-ADAMIC RESEARCH**

**Sciologistic Theory of Human Organisms  
Dominance of Monkeyism**

10 POINT

25 A 42 a \$4 35

**SELF-ACTING TELEPHONES**

**Instructive to the Egotistical and Self-conceited  
Hearing Sharpened and Made Acute  
Electrical Chatterbox**

9 POINT

25 A 42 a \$3 90

**OBSERVATIONS AFTER SUNDOWN**

**Youth's Glittering Flittings or Old Men's Experience  
Courtships and Merry-Making  
Selecting Partners**

8 POINT

25 A 42 a \$3 90

**THE TRAILING-SKIRT NUISANCE**

**Warranted Eventually to Kill every Devotee of Fashion  
Cheap and Inexpensive Sweepers for Cities  
Unsightly but Useful**

7 POINT

25 A 42 a \$3 85

**UNIVERSAL MODERN MARTYRS**

**Wasp-Waisted Feminines and Fashion's Daily Followers  
Exquisite Dandies and Shoe-Pinched Damsels  
High-heeled Promenaders**

6 POINT

30 A 52 a \$3 75

**NOTES ON THE LABOR QUESTION**

**Competency Speedily Acquired by Distributing Public Property  
Views of the Confirmed Loafers Do-Nothing Society  
Toil Reduced to a Minimum  
1 2 3 4 5 6 7 8 9 0**

---

AMERICAN TYPE FOUNDERS COMPANY

## Old Style Roman No 79

24 POINT

12 A 8 A 28 a \$6 95

THE first printing with an authentic printed date is a

16 POINT

12 A 8 A 32 a \$6 50

THE oldest type-printing bearing an authentic printed date is the Psalter of 1457, bearing the imprint of John

14 POINT

20 A 10 A 50 a \$5 21

THE oldest type-printing containing an authentic date is a Letter of Indulgence dated 1454, in which the date is written in. The oldest type-printing containing an authentic

12 POINT

28 A 18 A 82 a \$5 21

THE oldest type-printing containing an authentic date is a Letter of Indulgence dated 1454, in which the date is written in. The oldest type-printing containing an authentic printed date is the Psalter of 1457, which bears the imprint of John Fust of

10 POINT

40 A 20 A 80 a \$4 81

THE oldest type-printing containing an authentic date is a Letter of Indulgence, dated 1454, in which the date is written in. The oldest type-printing containing an authentic printed date is the Psalter of 1457, which bears the imprint of John Fust of Mentz and Peter Schœffer of Gernzheim. We also know of a Latin Bible, in folio, forty-two lines to the page, in

8 POINT

40 A 20 A 90 a \$4 17

THE oldest type-printing containing an authentic date is a Letter of Indulgence dated 1454, in which the date is written in. The oldest type-printing containing an authentic printed date is the Psalter of 1457, which bears the imprint of

8 POINT

40 A 20 A 100 a \$3 60

THE oldest type-printing containing an authentic date is a Letter of Indulgence dated 1454, in which the date is written in. The oldest type-printing containing an authentic printed date is the Psalter of 1457, which bears the imprint of John Fust of Mentz and Peter Schœffer of Gernzheim. We also know of a Latin Bible, in folio, forty-two lines to the page, in double col-

AMERICAN TYPE FOUNDERS COMPANY

## Old Style Italic No 79

24 POINT

8 A 14 a \$3 80

*The first printing with an authentic printed date is the*

18 POINT

10 A 24 a \$3 50

*The oldest type-printing bearing an authentic printed date is the Psalter of 1457, bearing the imprint of John*

14 POINT

18 A 38 a \$3 58

*The oldest type-printing containing an authentic date is a Letter of Indulgence dated 1454, in which the date is written in. The oldest type-printing containing an authentic*

12 POINT

20 A 50 a \$3 84

*The oldest type-printing containing an authentic date is a Letter of Indulgence dated 1454, in which the date is written in. The oldest type-printing containing an authentic printed date is the Psalter of 1457, which bears the imprint of John Fust of*

10 POINT

28 A 80 a \$3 51

*The oldest type-printing containing an authentic date is a Letter of Indulgence dated 1454, in which the date is written in. The oldest type-printing containing an authentic printed date is the Psalter of 1457, which bears the imprint of John Fust of Mentz and Peter Schaeffer of Gernzheim. We also know of a Latin Bible, in folio, forty-two lines to the page, in double columns, one copy of which*

8 POINT

28 A 80 a \$2 94

*The oldest type-printing containing an authentic date is a Letter of Indulgence dated 1454, in which the date is written in. The oldest type-printing containing an authentic printed date is the Psalter of 1457, which bears the imprint of John*

8 POINT

28 A 80 a \$2 87

*The oldest type-printing containing an authentic date is a Letter of Indulgence dated 1454, in which the date is written in. The oldest type-printing containing an authentic printed date is the Psalter of 1457, which bears the imprint of John Fust of Mentz and Peter Schaeffer of Gernzheim. We also know of a Latin Bible, in folio, forty-two lines to the page, in double col-*

Old Style No 43

40 POINT

5 A \$4 80

SUPERFINE

36 POINT

5 A \$3 80

UPHOLDING

26 POINT

8 A \$3 80

FIENDS

24 POINT

10 A \$3 45

BARREN

22 POINT

12 A \$3 05

PEOPLED

20 POINT

12 A \$2 85

HYMNALS

18 POINT

14 A \$2 40

MACHINIST

12 POINT

18 A \$1 95

PROTECTIONIST

Old Style No 44

38 POINT

5 A \$3 80

HEMS

24 POINT

10 A \$3 80

CHIMES

20 POINT

14 A \$3 80

INFERIOR

16 POINT

14 A \$2 40

PRINCESSES

12 POINT

18 A \$1 80

PHOTOGRAPHIC

10 POINT

25 A \$1 80

MOUNTED MUSICIANS

AMERICAN TYPE FOUNDERS COMPANY

**Old Style Condensed No 40**

36 POINT 7 A \$3 60

MISERS

24 POINT 12 A \$3 50

HURTFUL

20 POINT 18 A \$3 70

SPITZ DOGS

18 POINT 22 A \$3 10

TRUE WOMEN

12 POINT 30 A \$2 50

SACRED MEMOIRS

28 POINT 10 A \$3 65

CHINESE

22 POINT 18 A \$3 70

MANIFOLD

18 POINT 22 A \$3 30

YOUNG TREES

14 POINT 22 A \$2 75

SUMMER GOSSIP

10 POINT 36 A \$2 35

HARVESTING JUBILEE

**Old Style Condensed No 42**

38 POINT 8 A \$3 65

PRINTER

24 POINT 12 A \$2 90

NEW BOOKS

20 POINT 18 A \$3 00

SOUND HEADS

18 POINT 22 A \$2 75

HEARTY JOKERS

12 POINT 30 A \$2 15

STOMACHS CRAMMED

28 POINT 10 A \$3 35

CHERRIES

22 POINT 18 A \$3 10

IMPORTANCE

18 POINT 22 A \$2 90

SCHOOL BOARDS

14 POINT 22 A \$2 15

BIBULOUS INFANTS

10 POINT 36 A \$1 90

FORMIDABLE WAR VESSEL

38 POINT

7 A 10 a \$5 90

PROSPECTING  
Forsaken Gold Placers

30 POINT

8 A 12 a \$4 70

DIAMOND MINES  
Hunting Precious Treasure

24 POINT

10 A 18 a \$4 25

ARGENTAL DEPOSITS  
Desolate and Barren Landscape

18 POINT

12 A 22 a \$3 60

LUXURIOUS MANSIONS  
Dilapidated Shanties and Tenements

12 POINT

20 A 36 a \$3 20

COAL SEAMS  
Grain for Western Fuel

1234567890

9 POINT

25 A 40 a \$2 80

MERCHANT PRINCES  
Retired Wealthy Loungers

1234567890

**Old Style Condensed No 4**

48 POINT

6A 10a \$5 80

**SECTION CYLINDER**  
**Practical Automatic Registers**

40 POINT

6A 10a \$4 05

**REAL FRIEND BANNER**  
**Gratitude Rewards Human Hearts**

36 POINT

10A 15a \$4 50

**USEFUL PRECIOUS METAL**  
**Having Intrinsic and Exchange Values**

24 POINT

15A 20a \$3 60

**KIMBERLEY DIAMOND EXCHANGE**  
**South African Exploring and Mining Companies**

16 POINT

20A 30a \$3 30

**CHRISTMAS PRESENT**  
**Santa Claus Likes Little Ones**  
1 2 3 4 5 6 7 8 9 0

12 POINT

25A 40a \$2 40

**EVERY HUMAN HEART FINDS**  
**Consolation and Inspiration in Music**  
1 2 3 4 5 6 7 8 9 0

*Two styles of figures furnished with all sizes*

**AMERICAN TYPE FOUNDERS COMPANY**

Old Style Extended

48 POINT

4A 6a \$13 00 4A \$4 75

ONE Line

36 POINT

4A 6a \$6 00 4A \$2 50

Leader RUSH

24 POINT

6A 10a \$5 00 6A \$2 00

TROUBLES  
Customary Tribute

16 POINT

9A 12a \$3 50 9A \$2 00

CHURCH NEWS  
Transubstantiation Ethics

12 POINT

14A 22a \$3 50 14A \$1 50

MINUTES  
Dramatic School  
Elocutionists

10 POINT

16A 22a \$3 00 16A \$1 25

AMBITIOUS  
Scholars' Recitation  
Applauded

6 POINT

20A 30a \$3 00 16A \$1 00

MUNCHAUSEN  
Writer of Circus Poster  
Facts For Fiction  
1234567890

6 POINT

24A 30a \$2 75

SUMMER VERDURE  
Smiling Rainbow'd Meadow  
Drooping Blossoms  
1234567890

AMERICAN TYPE FOUNDERS COMPANY



Old Style Bold

48 POINT

4 A 8 a \$15 00

HE Dug

38 POINT

4 A 8 a \$9 50

GETS  
Sure Tips

24 POINT

5 A 7 a \$8 00

COLUMBIA  
Good Country

18 POINT

7 A 10 a \$4 50

PIRATICAL  
Mysterious Person

12 POINT

14 A 18 a \$4 00

MASTIFF  
Dog Howled

10 POINT

15 A 20 a \$3 50

DRUNKARD  
Foolish Dispute

8 POINT

18 A 24 a \$3 50

CALAMITY  
Howlers Muzzled  
1234567

8 POINT

18 A 22 a \$3 00

CONGRATULATE  
The Vigilant Officer  
12345678

AMERICAN TYPE FOUNDERS COMPANY

48 POINT

4 A 6 a \$6 00

BRIDGE  
Stone Arches

36 POINT

6 A 9 a \$7 10

WAYSIDE  
Hunting Ground

30 POINT

6 A 12 a \$6 00

FAVAWALE  
Designer of Fashions

24 POINT

10 A 15 a \$5 00

MONUMENTS  
Oldentime Remembrance  
Perpetuated

## Old Style Antique No 40

18 POINT

14 A 20 a \$4 10

### BUSINESS PROSPECT

## Increasing Confidence of Operators Profitable Undertaking

12 POINT

25 A 32 a \$3 65

### GLORIOUS CALIFORNIA CLIMATE

The soil and climate of California are well adapted to the cultivation of the grape. The delicious richness and flavor of California grapes are unsurpassed

**Experience** proves that the apprentice foreshadows the workman, just as surely as the bend of the twig

10 POINT

36 A 52 a \$4 05

### GROWTH OF GIGANTIC PLANTS

The Cactus grows spontaneously in California, and some of the inclosures are hedged in by this plant, which grows to an enormous size, and makes an impervious barrier against man and beast. Some of the stalks attain a height of fifteen feet

**Experience** proves that the apprentice foreshadows the workman, just as surely as the bend of the twig foretells the inclina-

8 POINT

38 A 70 a \$3 40

### ABUNDANCE OF GAME IN THE INTERIOR

The interior lakes and rivers swarm with myriads of wild geese, ducks, and other birds; the pheasant and partridge are numerous in the mountains. For salubrity the climate of California is superior to any other in the world. People sleeping most of the time in the open air never suffer the first pangs of ill-health, nor

**Experience** proves that the apprentice foreshadows the workman, just as surely as the bend of the twig foretells the inclination of tree. The industrious lad

6 POINT

38 A 70 a \$2 85

### EXTRAORDINARY MINERAL AND VEGETABLE PRODUCTIONS

Nearly all the fruits found in temperate and tropical climates can be produced in perfection in California. Wheat, barley, and other grains can be grown in the valleys without irrigation. Oats grow spontaneously, and with such rankness as to be considered a nuisance upon the soil, acres of them growing to such a height as to almost hide the cattle feeding among them

1 2 3 4 5 6 7 8 9 0

**Experience** proves that the apprentice foreshadows the workman, just as surely as the bend of the twig foretells the inclination of the tree. The upright, obedient, industrious lad will

AMERICAN TYPE FOUNDERS COMPANY

48 POINT

4 A 6 a \$7 00

# BLACK Snake

36 POINT

5 A 8 a \$5 50

# Colorado SYENITE

24 POINT

8 A 12 a \$4 50

# MYSTERIOUS Combination

18 POINT

12 A 16 a \$3 50

# Glorious Sunset SPLENDID SCENE

14 POINT

16 A 24 a \$3 25

**HISTORICAL**  
**Dangerous Precedent**

12 POINT

20 A 30 a \$3 00

**IRIDESCENT**  
**Dream Never Materialized**

11 POINT

22 A 34 a \$2 90

**CONGRATULATIONS**  
**Are Now Correctly in Order**

10 POINT

24 A 36 a \$2 75

**HONORABLE MENTION**  
**Made and a Premium Awarded**

9 POINT

28 A 42 a \$2 75

**CANDIDATE ELECTED**  
**Will Not Assume the Office Duties**

8 POINT

28 A 42 a \$2 50

**CONTRASTED CHARITIES**  
**One for Glory, the Other for Kindness**

7 POINT

26 A 40 a \$2 50

**TRUTH CRUSHED TO EARTH**  
**Will Rise Again, Through Eternal Years**

6 POINT No 1

24 A 38 a \$2 25

**PASSENGER STEAMER FOUNDERED**  
**Off the High and Rocky Coast of Madagascar**

1 2 3 4 5 6 7 8 9 0

1 2 3 4 5 6 7 8 9 0

Old Style Latin Condensed No 30

48 POINT

5 A 8 a \$4 85

FRESCO PAINTER  
Beautiful Rainbow Colors

40 POINT

5 A 10 a \$4 15

POPULAR TRIBUNES  
National Convention Rhetoric

36 POINT

8 A 12 a \$3 80

PROFESSION REPORTER  
Continuous Linguistic Performance

24 POINT

12 A 20 a \$3 65

ZEALOUS CAMPAIGN ORATORS  
International Monetary Problems Discussed

18 POINT

20 A 30 a \$3 40

SLANDER MEETING  
Notorious Matrons Nervous  
1 2 3 4 5 6 7 8 9 0

12 POINT

25 A 40 a \$2 45

TENDER HEART BEATS  
Ocular Institute for Blinded Lovers  
1 2 3 4 5 6 7 8 9 0

AMERICAN TYPE FOUNDERS COMPANY

## Century Roman

8 POINT

THE first number of *The Century* appeared in a modernized old-style type, which was then something of a novelty. It had never been used in any similar publication, and it gave distinction to the page. It had authority in its favor, as the outgrowth of a style (shown on pages 60-62, of the specimen book), introduced by WILLIAM CASLON of London about 1720, and then so pleasingly cut that it broke down every attempt at rivalry. For seventy years it was commended as incomparably the best cut of type, but it went out of fashion. At the beginning of the present century readers complained of its angularity and grayness.

Lower case a to z, 12 ems

ABCDEFGHIJKLMNOPQRSTUVWXYZ — \$1234567890

9 POINT

WHEN PICKERING and WHITTINGHAM revived the CASLON Old-Style, in 1850, using the identical matrices of the old master, the connoisseurs said, "Now at last we have returned to simplicity and beauty: this is perfection." Yet it was admired by bibliophiles only; dainty readers did not approve of its angular letters and its disproportioned capitals. Accepted for reprints of old books, it was rejected for modern work. To make it palatable to the general reader, type-founders devised a "modernized old-style," in which harsh features were modified and new features of greater delicacy were added. So changed, it became a more salable letter, but it never found marked favor with the ordinary newspaper or the book publisher. Critics said of it (too severely, we think) that the strong features of the Caslon face had been suppressed, and that the new features were no improvement; that it had *been made lighter, sharper, and broader, until its true character had been cut to pieces.*

Lower case a to z, 12<sup>1</sup>/<sub>4</sub> ems

ABCDEFGHIJKLMNOPQRSTUVWXYZ — \$1234567890

10 POINT

BIBLIOPHILES still prefer the cut of CASLON; with all its admitted faults, it is blacker, clearer, and more readable. The average reader rejects the angularities of the old and the new cut, and prefers the symmetry of types of modern fashion. In the bewildering variety of faces devised during this century, one peculiarity, the sharp hair-line (a fashion introduced by BODONI and DIDOT, in imitation of the delicate lines of the copper-plate printer), has never been changed. When printing was done upon wet paper, against an elastic blanket, the hair-line was necessarily thickened by its impress against the yielding paper, which over-lapped the sides of every line. Under this treatment the hair-line appeared thicker in print than in type, and was unobjectionable to printer or reader; but when the new method began (as it *did in 1872*) of printing on dry and smooth paper against an inelastic surface

Lower case a to z, 12 ems

ABCDEFGHIJKLMNOPQRSTUVWXYZ — \$1234567890

AMERICAN TYPE FOUNDERS COMPANY

# MR. THEODORE L. DEVINNE ON THE CENTURY ROMAN.

(From *The Century*, March, 1896.)

[NOTE.—This series of modern Roman type was cut by the American Type Founders' Company for *The Century*, in accordance with the suggestions and under the supervision of Mr. THEODORE L. DEVINNE, the eminent printer of that magazine. The punches were cut on the Benton punch-cutting machine from one set of drawings. A very complete line of accents has been added to meet the requirements of high-class book and magazine work.]

A GREAT change has taken place in the taste of readers, who have wearied of light types and gray impressions. There is an unmistakable demand for bold and stronger print. American type-founders recently introduced several styles of bold and black letter—for publishers and advertisers, as well as for bibliophiles. The “Jenson,” “Monotone,” and the “DeVenne” are in high favor with all, not for their novelty of form, but for their greater legibility. With these evidences before them of a general preference for bolder types, the publishers of *The Century* decided that they would swim with the tide, and have types of larger face and thicker hair-lines. According to old rules, Roman types would be bolder and more readable when made larger and wider. Experiments made with broad letters proved that increased expansion did not always secure increased legibility. The broad and round faces which seemed so beautiful in large-margined pages of Bodoni and Didot were not all beautiful (quite the reverse) when printed in double columns on a page with narrow margins. To use types in which the thick strokes of each type are unduly spread apart on a page with narrow margins is an incongruity that cannot be justified. When margins are ample, and space is not pinched, types may be broad and even expanded. When the page is over-full, the types should be compressed to suit the changed condition. The fault of over-broad type is most noticed in books of poetry, in which

the narrowness of the measure compels an overturning and mangling of lines, a waste of space, and needless irritation to the reader. Experiment proved that a book-type moderately compressed and properly cut was as readable as round or expanded type. Compressed types, first made in Holland in 1732, ever since have been more largely used than types of any other cut by the printers of France and southern Europe. In dictionaries and books of two or more columns to the page, the compressed face is a necessity. The slightness of the compression in this new face will be perceived at a glance in a comparison of the alphabets of the old and of the new face as here submitted.

abcdefghijklmnopqrstuvwxyzABCDM

THE NEW FACE.

abcdefghijklmnopqrstuvwxyz ABCD

THE OLD FACE.

The new face is as wide as the old; it has as much open space within as without each letter, and just as many letters to the line; it has the greater clearness of a thickened hair-line. It seems to be compressed only because it is taller, but this increase of height amounts to only sixty-five ten-thousandths ( $\frac{65}{10000}$ ) of an inch.

The story of the designing of this face is too full of technical detail to interest the casual reader. Only a maker of instruments of precision can appreciate the subservient tools, gauges, and machines that show aberrations of a ten-thousandth part of an inch; only an expert punch cutter can understand why minute geo-

# Modern Roman and Italic

3½ POINT NO 17

CARD FONT \$10 00

4¼ POINT NO 17

CARD FONT \$7 50

Experience proves that the apprentice foreshadows the workman, just as surely as the bend of the twig foretells the inclination of the tree. The upright, obedient, industrious lad will graduate a steady, skilful and capable man, as unmistakably as the perverse, idling, careless boy will ripen into a lazy, dissolute fellow. The fact is, a boy is measurably the maker of his own destiny; and if he fails to acquire a master-knowledge of the trade to which he is put, it will mainly be because he did not at his outset determine to be a master-workman. Good morals and steady industry are indispensable. When a lad who possesses these qualities proposes to learn the art and mystery of printing, it should be inquired of him, Has he had a fair common-school education? Is he a perfect speller? Has he a turn for reading? Is he under fifteen years of age? Is his eyesight good? A true affirmative answer to all these queries will entitle him to the position of reading and errand boy. He is told the hours at which he is to come and go, and a strict punctuality is enjoined upon him. He sweeps the room,—he sorts out the pi,—he learns the position of the various letters in the case. A year spent in this way is an excellent preparative for going to case, or learning the art of composing type. When he is put to composition, he is told to set up one line and show it to the foreman or to the journeyman under whose care he may be placed. The errors in the line are pointed out to him, and he is required to correct them himself. When the words are perfectly correct, he justifies the line tight enough to prevent it from falling down when the composing-stick is slightly inclined, and get sufficiently

ABCDEFHIJKLMNOPQRSTUVWXYZ  
1234567890

Experience proves that the apprentice foreshadows the workman, just as surely as the bend of the twig foretells the inclination of the tree. The upright, obedient, industrious lad will graduate a steady, skilful, and capable man, as unmistakably as the perverse, idling, careless boy will ripen into a lazy, dissolute fellow. The fact is, a boy is measurably the maker of his own destiny; and if he fails to acquire a master-knowledge of the trade to which he is put, it will mainly be because he did not at his outset determine to be a master-workman. Good morals and steady industry are indispensable. When a lad who possesses these qualities proposes to learn the art and mystery of printing, it should be inquired of him, Has he had a fair common-school education? Is he a perfect speller? Has he a turn for reading? Is his eyesight good? Is he under fifteen years of age? A true affirmative answer to all these queries will entitle him to the position of reading and errand boy. He is told the hours at which he is to come and go, and a strict punctuality is enjoined upon him. He sweeps the room,—he sorts out the pi,—he learns the position

ABCDEFHIJKLMNOPQRSTUVWXYZ  
1234567890

5 POINT NO 17

5 POINT NO 63

Experience proves that the apprentice foreshadows the workman, just as surely as the bend of the twig foretells the inclination of the tree. The upright, obedient, industrious lad will graduate a steady, skilful, and capable man, as unmistakably as the perverse, idling, careless boy will ripen into a lazy, dissolute fellow. The fact is, a boy is measurably the maker of his own destiny; and if he fails to acquire a master-knowledge of the trade to which he is put, it will mainly be because he did not at his outset determine to be a master-workman. Good morals and steady industry are indispensable. When a lad who possesses these qualities proposes to learn the art and mystery of printing, it should be inquired of him, Has he had a fair common-school education? Is he a perfect speller? Has he a turn for reading? Is his eyesight good? Is he under fifteen years of age? A true affirmative answer to all these queries will entitle him to the position of reading and errand boy. He is told the hours at which he is to come and go, and a strict punctuality is enjoined upon him. He

Lower case a to z, 14 ems  
ABCDEFHIJKLMNOPQRSTUVWXYZ  
1234567890

Experience proves that the apprentice foreshadows the workman, just as surely as the bend of the twig foretells the inclination of the tree. The upright, obedient, industrious lad will graduate a steady, skilful, and capable man, as unmistakably as the perverse, idling, careless boy will ripen into a lazy, dissolute fellow. The fact is, a boy is measurably the maker of his own destiny; and if he fails to acquire a master-knowledge of the trade to which he is put, it will mainly be because he did not at his outset determine to be a master-workman. Good morals and steady industry are indispensable. When a lad who possesses these qualities proposes to learn the art and mystery of printing, it should be inquired of him, Has he had a fair common-school education? Is he a perfect speller? Has he a turn for reading? A true affirmative answer to all these queries will entitle him to the position of reading and errand

Lower case a to z, 17 ems  
ABCDEFHIJKLMNOPQRSTUVWXYZ  
1234567890

5½ POINT NO 51

Experience proves that the apprentice foreshadows the workman, just as surely as the bend of the twig foretells the inclination of the tree. The upright, obedient, industrious lad will graduate a steady, skilful, and capable man, as unmistakably as the perverse, idling, careless boy will ripen into a lazy, dissolute fellow. The fact is, a boy is measurably the maker of his own destiny; and if he fails to acquire a master-knowledge of the trade to which he is put, it will mainly be because he did not at his outset determine to be a master-workman. Good morals and steady industry are indispensable. When a lad who possesses these qualities proposes to learn the art and mystery of printing, it should be inquired of him, Has he had a fair common-school education? Is he a perfect speller? Has he a turn for reading? Is his eyesight good? Is he under fifteen years of age? A true affirmative answer to all these queries will entitle him to the position of reading and errand boy. He is told the hours at which he is to come and go, and a strict punctuality is enjoined upon him. He sweeps the room,—he sorts out the pi,—he learns the position of the various letters in the case. A year spent in this way is an excellent preparative for going to case, or learning the art of composing type. When he is put to composition, he is told to set up one line and show it to the foreman or to the journeyman under whose care he may be placed. The errors in the line are pointed out to him, and he is required to correct them himself. When the words are perfectly correct, he justifies the line tight enough to prevent it from falling down when the composing-stick is slightly inclined, and yet sufficiently loose to enable him to lift it out with ease. In thus spacing out the line, the blanks between the words must be so graduated that, when the matter is printed, all the words will appear at equal distances apart. No matter how impatient he may be to get on, he must be drilled at this exercise till he becomes a thorough master of it. The grand doctrine to be instilled into him at first is, to do his work well and correctly; swiftness will follow as a natural consequence. He sets a second line; and after

Lower case a to z, 15 4-5 ems  
ABCDEFHIJKLMNOPQRSTUVWXYZ  
1234567890

AMERICAN TYPE FOUNDERS COMPANY



## Modern Roman and Italic

6 POINT NO 54

EXPERIENCE proves that the apprentice foreshadows the workman, just as surely as the bend of the twig foretells the inclination of the tree. The upright, obedient, industrious lad will graduate a steady, skilful, and capable man, as unmistakably as the perverse, idling, careless boy will ripen into a lazy, dissolute fellow. The fact is, a boy is measurably the maker of his own destiny; and if he fails to acquire a master-knowledge of the trade to which he is put, it will mainly be because he did not at his outset determine to be a master-workman. Good morals and steady industry are indispensable. When a lad who possesses these qualities proposes to learn the art and mystery of printing, it should be inquired of him, Has he had a fair common-school education? Is he a perfect speller? Has he a turn for reading? Is his eyesight good? Is he under fifteen years of age? A true affirmative answer to all these queries will entitle him to the position of reading and errand boy. He is told the hours at which he is to come and go, and a strict punctuality is enjoined upon him. He sweeps the room,—he sorts out the pi,—he learns the position of the various letters in the case. A year spent in this way is an excellent preparative for going to case, or learning the art of composing type. When he is put to composition, he is told to set up one line and show it to the foreman or to the journeyman under whose care he may be placed. The errors in the line are pointed out

Lower case a to z, 15 $\frac{3}{4}$  ems

ABCDEFGHIJKLMNPOQRSTUVWXYZ

1234567890

6 POINT NO 55

EXPERIENCE proves that the apprentice foreshadows the workman, just as surely as the bend of the twig foretells the inclination of the tree. The upright, obedient, industrious lad will graduate a steady, skilful, and capable man, as unmistakably as the perverse, idling, careless boy will ripen into a lazy, dissolute fellow. The fact is, a boy is measurably the maker of his own destiny; and if he fails to acquire a master-knowledge of the trade to which he is put, it will mainly be because he did not at his outset determine to be a master-workman. Good morals and steady industry are indispensable. When a lad who possesses these qualities proposes to learn the art and mystery of printing, it should be inquired of him, Has he had a fair common-school education? Is he a perfect speller? Has he a turn for reading? Is his eyesight good? Is he under fifteen years of age? A true affirmative answer to all these queries will entitle him to the position of reading and errand boy. He is told the hours at which he is to come and go, and a strict punctuality is enjoined upon him. He sweeps the room,—he sorts out the pi,—he learns the position of the various letters in the case. A year spent in this way is an excellent preparative for going to case, or learning the art of composing type. When he is put to composition, he is told to set up one line and show it to the foreman or to the journeyman under whose care he may be placed. The errors

Lower case a to z, 16 $\frac{1}{4}$  ems

ABCDEFGHIJKLMNPOQRSTUVWXYZ

1234567890

6 POINT NO 61

EXPERIENCE proves that the apprentice foreshadows the workman, just as surely as the bend of the twig foretells the inclination of the tree. The upright, obedient, industrious lad will graduate a steady, skilful, and capable man, as unmistakably as the perverse, idling, careless boy will ripen into a lazy, dissolute fellow. The fact is, a boy is measurably the maker of his own destiny; and if he fails to acquire a master-knowledge of the trade to which he is put, it will mainly be because he did not at his outset determine to be a master-workman. Good morals and steady industry are indispensable. When a lad who possesses these qualities proposes to learn the art and mystery of printing, it should be inquired of him, Has he had a fair common-school education? Is he a perfect speller? Has he a turn for reading? Is his eyesight good? Is he under fifteen years of age? A true affirmative answer to all these queries will entitle him to the position of reading and errand boy. He is told the hours at which he is to come and go, and a strict punctuality is enjoined upon him. He sweeps the room,—he sorts the pi,—he learns the position of the various letters in the case. A year spent in this way is an excellent preparative for going to case, or learning the art of composing type. When he is put to composition, he is told to set up one line and show it to the foreman or to the

Lower case a to z, 16 $\frac{3}{4}$  ems

ABCDEFGHIJKLMNPOQRSTUVWXYZ

1234567890

AMERICAN TYPE FOUNDERS COMPANY

## Modern Roman and Italic

7 POINT NO 54 <sup>c</sup>

EXPERIENCE proves that the apprentice foreshadows the workman, just as surely as the bend of the twig foretells the inclination of the tree. The upright, obedient, industrious lad will graduate a steady, skilful, and capable man, as unmistakably as the perverse, idling, careless boy will ripen into a lazy, dissolute fellow. The fact is, a boy is measurably the maker of his own destiny; and if he fails to acquire a master-knowledge of the trade to which he is put, it will mainly be because he did not at his outset determine to be a master-workman. Good morals and steady industry are indispensable. When a lad who possesses these qualities proposes to learn the art and mystery of printing, it should be inquired of him, Has he had a fair common-school education? Is he a perfect speller? Has he a turn for reading? Is his eyesight good? Is he under fifteen years of age? *A true affirmative answer to all these queries will entitle him to the position of reading and errand boy. He is told the hours at which he is to come and go, and a strict punctuality is enjoined upon him. He sweeps*

Lower case a to z, 15 ems

ABCDEFGHIJKLMN OPQRSTUVWXYZ

1234567890

7 POINT NO 55 <sup>c</sup>

EXPERIENCE proves that the apprentice foreshadows the workman, just as surely as the bend of the twig foretells the inclination of the tree. The upright, obedient, industrious lad will graduate a steady, skilful, and capable man, as unmistakably as the perverse, idling, careless boy will ripen into a lazy, dissolute fellow. The fact is, a boy is measurably the maker of his own destiny; and if he fails to acquire a master-knowledge of the trade to which he is put, it will mainly be because he did not at his outset determine to be a master-workman. Good morals and steady industry are indispensable. When a lad who possesses these qualities proposes to learn the art and mystery of printing, it should be inquired of him, Has he had a fair common-school education? Is he a perfect speller? Has he a turn for reading? Is his eyesight good? Is he under fifteen years of age? *A true affirmative answer to all these queries will entitle him to the position of reading and errand boy. He is told the hours at which he is to come and go, and a strict punctuality is enjoined upon him. He sweeps the*

Lower case a to z, 14½ ems

ABCDEFGHIJKLMN OPQRSTUVWXYZ

1234567890

7 POINT NO 61 <sup>d</sup>

EXPERIENCE proves that the apprentice foreshadows the workman, just as surely as the bend of the twig foretells the inclination of the tree. The upright, obedient, industrious lad will graduate a steady, skilful, and capable man, as unmistakably as the perverse, idling, careless boy will ripen into a lazy, dissolute fellow. The fact is, a boy is measurably the maker of his own destiny; and if he fails to acquire a master-knowledge of the trade to which he is put, it will mainly be because he did not at his outset determine to be a master-workman. Good morals and steady industry are indispensable. When a lad who possesses these qualities proposes to learn the art and mystery of printing, it should be inquired of him, Has he had a fair common-school education? Is he a perfect speller? Has he a turn for reading? Is his eyesight good? Is he under fifteen years of age? *A true affirmative answer to all these queries will entitle him to the position of reading and errand boy. He is told the hours at which he is to*

Lower case a to z, 15⅔ ems

ABCDEFGHIJKLMN OPQRSTUVWXYZ

1234567890

AMERICAN TYPE FOUNDERS COMPANY

## Modern Roman and Italic

8 POINT NO 54

EXPERIENCE proves that the apprentice foreshadows the workman, just as surely as the bend of the twig foretells the inclination of the tree. The upright, obedient, industrious lad will graduate a steady, skilful, and capable man, as unmistakably as the perverse, idling, careless boy will ripen into a lazy, dissolute fellow. The fact is, a boy is measurably the maker of his own destiny; and if he fails to acquire a master-knowledge of the trade to which he is put, it will mainly be because he did not at his outset determine to be a master-workman. Good morals and steady industry are indispensable. When a lad who possesses these qualities proposes to learn the art and mystery of printing, it should be inquired of him, Has he had a fair common-school education? Is he a perfect speller? Has he a desire for reading? Is his eyesight good? Is he under fifteen years of age? A true affirmative answer to these queries will entitle him to the position of reading and errand boy. He is told the hours at which he is to come and go, and a strict punctuality is enjoined upon him. He sweeps the room,—he sorts out the pi,—he learns the position of the various letters in the case. A year spent in this way is an excellent preparative for going to case, or learning the art of composing type. When he is put to composition, he is told to set up one line and show it to the foreman or to the journeyman under whose care he may be placed. The errors in the line are pointed out to him, and he is required to correct them himself

Lower case a to z, 14¼ ems

ABCDEFGHIJKLMNOPQRSTUVWXYZ

1234567890

8 POINT NO 55

EXPERIENCE proves that the apprentice foreshadows the workman, just as surely as the bend of the twig foretells the inclination of the tree. The upright, obedient, industrious lad will graduate a steady, skilful, and capable man, as unmistakably as the perverse, idling, careless boy will ripen into a lazy, dissolute fellow. The fact is, a boy is measurably the maker of his own destiny; and if he fails to acquire a master-knowledge of the trade to which he is put, it will mainly be because he did not at his outset determine to be a master-workman. Good morals and steady industry are alike indispensable. When a lad who possesses these qualities proposes to learn the art and mystery of printing, it should be inquired of him, Has he had a fair common-school education? Is he a perfect speller? Has he a turn for reading? Is his eyesight good? Is he under fifteen years of age? A true affirmative answer to all these queries will entitle him to the position of reading and errand boy. He is told the hours at which he is to come and go, and a strict punctuality is enjoined upon him. He sweeps the room,—he sorts out the pi,—he learns the position of the various letters in the case. A year spent in this way is an excellent preparative for going to case, or learning the art of composing type. When he is put to composition he is told to set up one line and show it to the foreman or to the journeyman under whose care he may be placed. The errors in the line are pointed out to him, and he is required to correct them himself. When the words are perfectly correct, he

Lower case a to z, 13¼ ems

ABCDEFGHIJKLMNOPQRSTUVWXYZ

1234567890

AMERICAN TYPE FOUNDERS COMPANY

## Modern Roman and Italic

8 POINT NO 61 °

EXPERIENCE proves that the apprentice foreshadows the workman, just as surely as the bend of the twig foretells the inclination of the tree. The upright, obedient, industrious lad will graduate a steady, skilful and capable man, as unmistakably as the perverse, idling, careless boy will ripen into a lazy, dissolute fellow. The fact is, a boy is measurably the maker of his own destiny; and if he fails to acquire a master-knowledge of the trade to which he is put, it will mainly be because he did not at his outset determine to be a master-workman. Good morals and steady industry are indispensable. When a lad who possesses these qualities proposes to learn the art and mystery of printing, it should be inquired of him, Has he had a fair common-school education? Is he a perfect speller? Has he a turn for reading? Is his eyesight good? Is he under fifteen years of age? A true affirmative answer to all these queries will entitle him to the position of reading and errand boy. He is told the hours at which he is to come and go, and a strict punctuality is enjoined upon him. He sweeps the room,—he sorts out the pi,—he learns the position of the various letters in the case. A year spent in this way is an excellent preparative for going to case, or learning the art of composing type. When he is put to composition, *he is told to set up one line and show it to the foreman or to the journeyman under whose care he may be placed. The errors in the line are pointed out to him, and he is required to correct them him-*

Lower case a to z, 14½ ems

ABCDEFGHIJKLMN OPQRSTUVWXYZ

1234567890

8 POINT NO 54 °

EXPERIENCE proves that the apprentice foreshadows the workman, just as surely as the bend of the twig foretells the inclination of the tree. The upright, obedient, industrious lad will graduate a steady, skilful, and capable man, as unmistakably as the perverse, idling, careless boy will ripen into a lazy, dissolute fellow. The fact is, a boy is measurably the maker of his own destiny; and if he fails to acquire a master-knowledge of the trade to which he is put, it will mainly be because he did not at his outset determine to be a master-workman. Good morals and steady industry are indispensable. When a lad who possesses these qualities proposes to learn the art and mystery of printing, it should be inquired of him, Has he had a fair common-school education? Is he a perfect speller? Has he a turn for reading? Is his eyesight good? Is he under fifteen years of age? A true affirmative answer to all these queries will entitle him to the position of reading and errand boy. He is told the hours at which he is to come and go, and a strict punctuality is enjoined upon him. *He sweeps the room,—he sorts out the pi,—he learns the position of the various letters in the case. A year spent in this way is an excellent preparative for going to case, or learn-*

Lower case a to z, 13 ems

ABCDEFGHIJKLMN OPQRSTUVWXYZ

1234567890

AMERICAN TYPE FOUNDERS COMPANY

## Modern Roman and Italic

9 POINT NO 55 °

EXPERIENCE proves that the apprentice foreshadows the workman, just as surely as the bend of the twig foretells the inclination of the tree. The upright, obedient, industrious lad will graduate a steady, skilful, and capable man, as unmistakably as the perverse, idling, careless boy will ripen into a lazy, dissolute fellow. The fact is, a boy is measurably the maker of his own destiny; and if he fails to acquire a master-knowledge of the trade to which he is put, it will mainly be because he did not at his outset determine to be a master-workman. Good morals and steady industry are indispensable. When a lad who possesses these qualities proposes to learn the art and mystery of printing, it should be inquired of him, Has he had a fair common-school education? Is he a perfect speller? Has he a turn for reading? Is his eyesight good? Is he under fifteen years of age? A true affirmative answer to all these queries will entitle him to the position of reading and errand boy. He is told the hours at which he is to come and go, and a strict *punctuality is enjoined upon him. He sweeps the room,—he sorts out the pi,—he learns the position of the various letters in the case. A year spent in this way is an excellent preparative for going to case*

Lower case a to z, 13 ems

ABCDEFGHIJKLMN OPQRSTUVWXYZ

1234567890

9 POINT NO 61 °

EXPERIENCE proves that the apprentice foreshadows the workman, just as surely as the bend of the twig foretells the inclination of the tree. The upright, obedient, industrious lad will graduate a steady, skilful, and capable man, as unmistakably as the perverse, idling, careless boy will ripen into a lazy, dissolute fellow. The fact is, a boy is measurably the maker of his own destiny; and if he fails to acquire a master-knowledge of the trade to which he is put, it will mainly be because he did not at his outset determine to be a master-workman. Good morals and steady industry are indispensable. When a lad who possesses these qualities proposes to learn the art and mystery of printing, it should be inquired of him, Has he had a fair common-school education? Is he a perfect speller? Has he a turn for reading? Is his eyesight good? Is he under fifteen years of age? A true affirmative answer to all these queries will entitle him to the position of reading and errand boy. *He is told the hours at which he is to come and go, and a strict punctuality is enjoined upon him. He sweeps the room,—he sorts out the pi,—he learns the position*

Lower case a to z, 15¼ ems

ABCDEFGHIJKLMN OPQRSTUVWXYZ

1234567890

AMERICAN TYPE FOUNDERS COMPANY

## Modern Roman and Italic

10 POINT NO 54    c

EXPERIENCE proves that the apprentice foreshadows the workman, just as surely as the bend of the twig foretells the inclination of the tree. The upright, obedient, industrious lad will graduate a steady, skilful, and capable man, as unmistakably as the perverse, idling, careless boy will ripen into a lazy, dissolute fellow. The fact is, a boy is measurably the maker of his own destiny; and if he fails to acquire a master-knowledge of the trade to which he is put, it will mainly be because he did not at his outset determine to be a master-workman. Good morals and steady industry are indispensable. When a lad who possesses these qualities proposes to learn the art and mystery of printing, it should be inquired of him, Has he had a fair common-school education? Is he a perfect speller? Has he a turn for reading? Is his eyesight good? *Is he under fifteen years of age? A true affirmative answer to all these queries will entitle him to the position of reading and errand boy. He is told the hours at which he is to come and go and a strict*

Lower case a to z, 12 3-5 ems

ABCDEFGHIJKLMNOPQRSTUVWXYZ

1234567890

10 POINT NO 55    c

EXPERIENCE proves that the apprentice foreshadows the workman, just as surely as the bend of the twig foretells the inclination of the tree. The upright, obedient, industrious lad will graduate a steady, skilful, and capable man, as unmistakably as the perverse, idling, careless boy will ripen into a lazy, dissolute fellow. The fact is, a boy is measurably the maker of his own destiny; and if he fails to acquire a master-knowledge of the trade to which he is put, it will mainly be because he did not at his outset determine to be a master-workman. Good morals and steady industry are indispensable. When a lad who possesses these qualities proposes to learn the art and mystery of printing, it should be inquired of him, Has he had a fair common-school education? Is he a perfect speller? Has he a turn for reading? Is his eyesight good? *Is he under fifteen years of age? A true affirmative answer to all these queries will entitle him to the position of read*

Lower case a to z, 12 4-5 ems

ABCDEFGHIJKLMNOPQRSTUVWXYZ

1234567890

AMERICAN TYPE FOUNDERS COMPANY

## Modern Roman and Italic

11 POINT No 52 °

EXPERIENCE proves that the apprentice foreshadows the workman, just as surely as the bend of the twig foretells the inclination of the tree. The upright, obedient, industrious lad will graduate a steady, skilful, and capable man, as unmistakably as the perverse, idling, careless boy will ripen into a lazy, dissolute fellow. The fact is, a boy is measurably the maker of his own destiny; and if he fails to acquire a master-knowledge of the trade to which he is put, it will mainly be because he did not at his outset determine to be a master-workman. Good morals and steady industry are indispensable. When a lad who possesses these qualities proposes to learn the art and mystery of printing, it should be inquired of him, *Has he had a fair common-school education? Is he a perfect speller? Has he a turn for reading? Is his eyesight good? Is he under fifteen years of age? A true affirmative answer to all these queries will entitle him*

Lower case a to z, 11½ ems

ABCDEFGHIJKLMNOPQRSTUVWXYZ

1234567890

11 POINT No 54 °

EXPERIENCE proves that the apprentice foreshadows the workman, just as surely as the bend of the twig foretells the inclination of the tree. The upright, obedient, industrious lad will graduate a steady, skilful, and capable man, as unmistakably as the perverse, idling, careless boy will ripen into a lazy, dissolute fellow. The fact is, a boy is measurably the maker of his own destiny; and if he fails to acquire a master-knowledge of the trade to which he is put, it will mainly be because he did not at his outset determine to be a master-workman. Good morals and steady industry are indispensable. When a lad who possesses these qualities proposes to learn the art and mystery of printing, it should be inquired of him, *Has he had a fair common-school education? Is he a perfect speller? Has he a turn for reading? Is his eyesight good? Is he under fifteen years of age? A true affirmative*

Lower case a to z, 12¼ ems

ABCDEFGHIJKLMNOPQRSTUVWXYZ

1234567890

AMERICAN TYPE FOUNDERS COMPANY

## Modern Roman and Italic

12 POINT NO 52

EXPERIENCE proves that the apprentice foreshadows the workman, just as surely as the bend of the twig foretells the inclination of the tree. The obedient, upright, assiduous lad will graduate a steady, skilful, and capable man, as unmistakably as the perverse, idling, careless boy will ripen into a lazy, dissolute fellow. The fact is, a boy is measurably the maker of his own destiny; and if he fails to acquire a master-knowledge of the trade to which he is put, it will mainly be because he did not at his outset determine to be a master-workman. *Good morals and steady industry are indispensable. When a lad who possesses these qualities proposes to learn the art and mystery of printing, it should be inquired of him,*

Lower case a to z, 12 ems

ABCDEFGHIJKLMNOPQRSTUVWXYZ

1234567890

12 POINT NO 54

EXPERIENCE proves that the apprentice foreshadows the workman, just as surely as the bend of the twig foretells the inclination of the tree. The upright, obedient, industrious lad will graduate a steady, skilful, and capable man, as unmistakably as the perverse, idling, careless boy will ripen into a lazy, dissolute fellow. The fact is, a boy is measurably the maker of his own destiny; and if he fails to acquire a master-knowledge of the trade to which he is put, it will mainly be because he did not at his outset determine to be a master-workman. *Good morals and steady industry are indispensable. When a lad who possesses these qualities proposes to learn the art and mystery of printing, it*

Lower case a to z, 12 $\frac{3}{4}$  ems

ABCDEFGHIJKLMNOPQRSTUVWXYZ

1234567890

AMERICAN TYPE FOUNDERS COMPANY



## Modern Roman and Italic

14 POINT NO 44

EXPERIENCE proves that the apprentice foreshadows the workman, just as surely as the bend of the twig foretells the inclination of the tree. The upright, obedient, industrious lad will graduate a steady, skilful, and capable man, as unmistakably as the perverse, idling, careless boy will ripen into a lazy, dissolute fellow. The fact is, a boy is measurably the maker of his own destiny; and if he fails to *acquire a master-knowledge of the trade to which he is put, it will mainly be because he did not at his outset determine to be a master-work*

ABCDEFGHIJKLMNOPQRSTUVWXYZ

1234567890

18 POINT NO 43

EXPERIENCE proves that the apprentice foreshadows the workman, just as surely as the bend of the twig foretells the inclination of the tree. The upright, obedient, assiduous lad will graduate a steady, skilful, and *capable man, as unmistakably as the perverse, idling, careless boy will ripen into a lazy, dissolute fellow. The fact*

ABCDEFGHIJKLMNOPQRSTUVWXYZ

1234567890

AMERICAN TYPE FOUNDERS COMPANY

**Roman No 44**

18 POINT

25 LBS. \$10 00

**BEAUTY OF SIMPLICITY**

**PLAIN TYPE** is always an evidence of taste  
**1234567890**

22 POINT

26 A 12 A 90 a \$13 80

**INVESTMENT**

**HOUSE FOR SALE** on Easy Terms

28 POINT

14 A 7 A 42 a \$12 00

**SUMMER RECREATION**  
**Country Resorts**

36 POINT

14 A 42 a \$16 00

**STRONG Extracts**

44 POINT

8 A 20 a \$14 80

**Brown SUITS**

60 POINT

4 A 4 a \$8 95

**THE Race**

*Italic furnished for the 18, 22, 28 and 36 Point on special order*

**AMERICAN TYPE FOUNDERS COMPANY**

Lightface Condensed No 46

72 POINT

5 A 6 a \$18 95

Sister MINE

60 POINT

5 A 7 a \$12 40

NINE Hundred

46 POINT

7 A 10 a \$10 95

Frightened SHEEP

36 POINT

10 A 20 a \$7 75

GRECIAN School Teachers

26 POINT

14 A 20 a \$6 60

RESTING  
Drowsy Servant

20 POINT

14 A 28 a \$3 80

LIFE-RESTORER  
Vigorous Daily Exercises

16 POINT

14 A 28 a \$3 30

MYSTIC CIRCLE  
Distinguished Speakers  
12345678

12 POINT

25 A 52 a \$3 40

ERUDITE WRITINGS  
Conundrums by Literatim Pensnip  
1234567890

**Lightface Condensed No 44**

28 POINT

12 A \$3 85

**URGING THE HORSE**

24 POINT

10 A \$2 75

**BROTHERS**

22 POINT

14 A \$2 95

**REPRESENT**

20 POINT

14 A \$2 65

**INQUISITIVE**

16 POINT

16 A \$2 75

**RIVER BANKS**

18 POINT

16 A \$2 45

**GOLD HUNTERS**

14 POINT

22 A \$2 50

**TIMELY CUSTOMS**

12 POINT

25 A \$2 25

**SOCIAL GATHERING**

10 POINT

36 A \$2 05

**INVENTIVE MACHINISTS**

**Lightface Condensed No 47**

28 POINT

14 A \$3 75

**PERSEVERING REGIMENT**

24 POINT

14 A \$3 30

**PERFECTING**

22 POINT

18 A \$3 20

**BUSY BUILDER**

20 POINT

18 A \$2 95

**EXPERT MINER**

18 POINT

22 A \$2 85

**GUITAR CONCERT**

16 POINT

22 A \$2 45

**ROADSIDE HOUSES**

14 POINT

25 A \$2 50

**ROAMING MUSICIANS**

12 POINT

36 A \$2 60

**LANDSCAPE PAINTERS**

10 POINT

36 A \$1 85

**ELEPHANTINE RESEARCHES**

**AMERICAN TYPE FOUNDERS COMPANY**

Lightface Condensed No 45

72 POINT

5 A \$9 65

REMO TEST

48 POINT

7 A \$7 00

TRIBE

44 POINT

7 A \$6 50

CHIEF

40 POINT

7 A \$4 25

EXERT

36 POINT

10 A \$4 25

RECEIPTS

26 POINT

14 A \$3 60

MENTIONINGS

20 POINT

16 A \$2 60

CONTRIBUTIONS

16 POINT

18 A \$1 90

COMPLETED SKETCH

16 POINT

22 A \$2 25

MEADOW COUNTRIES

12 POINT

36 A \$2 30

PICTURESQUE MANSIONS

10 POINT

36 A \$1 55

PROVISIONS FOR THE INFANTRY

9 POINT

52 A \$2 05

HERBACEOUS TREES AND FLOWERS

6 POINT

52 A \$1 60

SMALL BODIES WITH GIGANTIC SOULS

1234567890

1234567890

AMERICAN TYPE FOUNDERS COMPANY

**Lightface No 46**

28 POINT

7 A \$3 10

**MINERS**

24 POINT

10 A \$3 15

**STRINGS**

22 POINT

14 A \$3 65

**INSERTED**

20 POINT

14 A \$3 20

**OLD MISER**

18 POINT

18 A \$3 25

**GOOD KNIFE**

18 POINT

18 A \$2 95

**RARE FRUIT**

14 POINT

18 A \$2 70

**COPPER MINE**

12 POINT

25 A \$2 50

**MARKET REPORT**

11 POINT

38 A \$2 55

**MOUNTAIN HOUSES**

10 POINT

38 A \$2 60

**SOLEMN JUVENILES**

**Lightface No 43**

38 POINT

8 A \$3 90

**RIDER**

28 POINT

10 A \$3 90

**HONEST**

24 POINT

10 A \$3 15

**DUTIFUL**

22 POINT

14 A \$3 25

**BELIEVED**

20 POINT

14 A \$2 90

**FINE GOLD**

18 POINT

18 A \$3 00

**MUSTY GEMS**

18 POINT

18 A \$2 70

**TIGER CIRCUS**

14 POINT

18 A \$2 45

**LODGE HOUSES**

12 POINT

25 A \$2 50

**HOMES BURNING**

10 POINT

38 A \$2 45

**SPIRIT INFLUENCES**

AMERICAN TYPE FOUNDERS COMPANY

## Lightface No 44

24 POINT

10 A \$3 45

IMPORTED FRINGE

22 POINT

10 A \$2 70

UTENSILS

20 POINT

14 A \$3 20

PREMIERS

18 POINT

18 A \$2 80

RECORDER

18 POINT

18 A \$2 95

FINE SCENE

14 POINT

18 A \$2 80

BRIGHT MEN

12 POINT

25 A \$2 70

LIGHT RUNNER

10 POINT

30 A \$2 10

SOUTHERN SPRINGS

1234567890

9 POINT

30 A \$1 85

PUGILISTIC STRUGGLE

1234567890

## Half-Title No 40

18 POINT

14 A \$2 40

GENEROUS MOUNTAINEER

14 POINT

18 A \$2 80

COLD DRINKS

12 POINT

22 A \$2 55

NICEST HORSE

11 POINT

25 A \$2 35

REMOTE PLACES

10 POINT

30 A \$2 15

PRINTING MACHINE

8 POINT

30 A \$1 80

WELCOME PROOFSHEETS

1234567890

8 POINT

36 A \$1 80

REMARKABLE CONTINGENCIES

1234567890

AMERICAN TYPE FOUNDERS COMPANY

## Boldface Roman No 40

12 POINT

22 A 32 a \$3 90

# PROTECTION TO COUNTRY Honest Politicians and Industrious People

10 POINT

36 A 52 a \$4 50

**DISCLOSED**  
Thorough Examinations  
Private Business

7 POINT

36 A 70 a \$3 90

**MISSING DEPOSITS**  
Treasurers, Clerks and Managers  
Traced in Foreign Climes  
1234567890

6 POINT

36 A 70 a \$4 40

**SERVICE REFORM**  
Political Berths for Aspirants  
Broken Pledges

6 POINT

36 A 70 a \$3 00

**COLLEGE OF RARITIES**  
Youngsters who Don't Expect to Begin  
Where their Parents Left Off  
1234567890

## Boldface Italic No 40

16 POINT NO 40

18 A 26 a \$5 25

***TUNNELS***  
*Gloomy Passages*

10 POINT

36 A 52 a \$4 55

***MANLINESS***  
*Mannerly and Courteous*

7 POINT NO 40

36 A 70 a \$4 00

***ARCTIC POLAR CIRCLE***  
*Perennial Life and Greensward*  
1234567890

12 POINT

22 A 32 a \$4 25

***FRIENDLY***  
*Assisting Neighbors*

6 POINT

36 A 70 a \$4 30

***STATE PRISON***  
*National School for Reformers*

6 POINT

36 A 70 a \$3 15

***INFORMATION DESIRED***  
*Concerning the Color of Electric Fluid*  
1234567890

## Half-Title No 42

6 POINT

30 A 60 a \$4 00

**CHAPEL ASSEMBLY**  
Undecipherable Manuscript  
1234567890

6 POINT

36 A 70 a \$3 55

**COMMINGLING NATIONS**  
Scaplock and Chopstick Fraternity  
1234567890

AMERICAN TYPE FOUNDERS COMPANY



Title No 43

18 POINT

14 A 20 a \$5 30

**GOSSIP CORNERS**  
**Scandal Hatching Concerns**

14 POINT

18 A 32 a \$5 20

**AUCTION BARGAINS**  
**Descriptive Catalogues Furnished**

12 POINT

22 A 32 a \$4 45

**ECONOMICS**  
**Existing on Charity**

8 POINT

36 A 70 a \$4 60

**CLEAR RECORDS**  
**Furnished for Malefactors**

6 POINT

36 A 70 a \$3 45

**KNOWLEDGE INJECTOR**  
**Science Forced into the Cerebrum**  
**1234567890**

10 POINT

36 A 52 a \$4 70

**INDUCEMENTS**  
**Openings for Fortunes**

7 POINT

36 A 70 a \$4 50

**ANNOUNCEMENT**  
**Remarkable Calico Bargains**

5½ POINT

36 A 70 a \$3 60

**HUMBUG OINTMENTS**  
**Singularly Efficacious Medicaments**  
**1234567890**

Title Italic No 42

12 POINT

10 A 28 a \$2 95

**WONDERFUL ECONOMY**  
**Improved Motive Power Without Boilers**

10 POINT

14 A 36 a \$3 25

**CONDENSING**  
**Planetary Cohobation**

6 POINT

24 A 70 a \$3 05

**MAGNETIC MACHINES**  
**Attracting Metal from the Moon**  
**1234567890**

8 POINT

14 A 42 a \$3 15

**CLEAN SWEEP**  
**Automatic House Cleaner**

5½ POINT

24 A 70 a \$3 35

**MICROSCOPIC MINING**  
**Liquid Minerals in Cold Atmosphere**  
**1234567890**

AMERICAN TYPE FOUNDERS COMPANY

Extra Condensed No 43

98 POINT

7 A \$12 80

SIGHT FOR BOYS

72 POINT

7 A \$8 40

MEMBERS

60 POINT

10 A \$8 20

DESIGNERS

44 POINT

10 A \$8 30

PRODUCTIONS

40 POINT

14 A \$4 80

ROMAN EXTRACTS

38 POINT

14 A \$3 80

LONDON PROFESSORS

24 POINT

22 A \$4 50

SPRINGTIME EXCURSION

20 POINT

25 A \$3 40

GIGANTIC CALIFORNIA TREES

12 POINT

36 A \$2 60

BOARDING HOUSE BEANSOUP DILUTION

8 POINT

52 A \$2 70

MAMMOTH EXHIBITION OF NATIONAL CURIOSITIES  
1234567890

8 POINT

52 A \$2 00

CONCRETED DIMINUTIVE FOLKS PROVOKING ABUNDANCE OF HUMOR  
1234567890

AMERICAN TYPE FOUNDERS COMPANY

**Extra Condensed No 46**

80 POINT

5 A 8 a \$7 70

Marching **DOUBLE** Platoons

44 POINT

6 A 8 a \$8 35

**TWILIGHT** Approaching **DARKNESS**

40 POINT

8 A 10 a \$5 30

Pine Tree **SAPLING**

28 POINT

10 A 14 a \$4 40

Sentences **LONGDRAWN**

18 POINT

18 A 25 a \$3 80

**WONDERFUL INSTRUCTOR**  
Calisthenic Exercises Recommended

22 POINT

18 A 20 a \$4 05

**LECTURE EXERCISES**  
Amateur Literary Associations

14 POINT

20 A 28 a \$3 30

**IMPECUNIOUS PERSONS**  
Entertained by Turnupnose Social Circles  
1 2 3 4 5 6 7 8 9 0

12 POINT

25 A 38 a \$3 55

**PROFESSOR LONGSHANKS**  
Addresses Intended to Promote Happiness  
1 2 3 4 5 6 7 8 9 0

**Extra Condensed No 40**

12 POINT

25 A 52 a \$4 40

**WHO THUS HAS FALLEN, HOW PITEOUS HIS FALL!**

A hat's the dome, the steeple-top of thought; the attic room, the cockloft of the head; the hive

10 POINT

38 A 70 a \$4 15

**PRETENSIONS WITH DIMENSIONS**  
A hat's the dome, the steeple-top of thought; the attic room, the cockloft of the head; the hive where  
1 2 3 4 5 6 7 8 9 0

8 POINT

38 A 70 a \$3 80

**CLIMBING TO GIDDY HEIGHTS**  
A hat's the dome, the steeple-top of thought; the attic room, the cockloft of the head; the hive where Fancy's honey-bees  
1 2 3 4 5 6 7 8 9 0

**AMERICAN TYPE FOUNDERS COMPANY**

48 POINT

6 A 6 a \$7 05

# Pretty SONGBIRD Musicians

40 POINT

6 A 10 a \$6 80

# Peaceful HOUSEHOLD Comforts

28 POINT

10 A 14 a \$6 05

# UPRIGHT IN CONDUCT Honest Dealing and Courteous Manner

22 POINT

16 A 20 a \$5 65

## HORSE JOCKEYS Exciting the Winners

18 POINT

16 A 25 a \$5 15

## SCENE IN PARLOR Interesting Caudle Lecture

14 POINT

20 A 28 a \$4 10

## EXHAUSTED GRANARY Empty Purses and no Resource

12 POINT

30 A 36 a \$4 80

## MODERN PARADOX Law-Abiding State Representative

10 POINT

30 A 42 a \$3 90

## TRANSITIONAL NOTIONS Monkey Capers of Frolicsome Boyhood

9 POINT

36 A 52 a \$4 30

## LEGISLATIVE ANALYSIS Tests Applied to Detect Legislative Bribery

6 POINT

36 A 52 a \$4 10

## ARCHITECTURAL DESIGNS Beautiful Illustrations of Novel Aerial Castles 1234567890

6 POINT

36 A 70 a \$3 55

## PROBLEM OF SOCIAL FASHIONS The Breadth and Depth of their Influence upon Society 1234567890

**Condensed Title No 43**

48 POINT

7 A 10 a \$12 85

**HOUSE Barons**

44 POINT

7 A 10 a \$10 85

**Shining BRIGHT**

38 POINT

10 A 20 a \$11 20

**TRUE  
Magnates**

28 POINT

14 A 20 a \$8 60

**HAPPY  
Merry Girls**

22 POINT

14 A 28 a \$5 75

**CONTENT  
Robust Health**

18 POINT

18 A 28 a \$4 55

**PORTENTS  
Presaging Cyclones**

14 POINT

22 A 32 a \$4 10

**DIVERTING  
Stereotyped Jocosity**

12 POINT

25 A 52 a \$4 80

**BOMBPROOFS  
Retreat for Magistrates**

10 POINT

36 A 70 a \$3 90

**LIGHTFINGERS  
Dexterous Diamond Grabbers**

8 POINT

36 A 70 a \$3 55

**GOOD SOCIETY SCHOOL  
Unsophisticated Maidens Instructed**

8 POINT

36 A 70 a \$2 80

**PETIFOOLISH INSTITUTE  
Training Tonish Ladies in Practical Manners  
1234567890**

5 POINT

36 A 70 a \$2 70

**PIPE LINE TO PETROLEUM CENTRE  
Broad Tracts of Rocky Ground Cultivated by Speculators  
1234567890**

**AMERICAN TYPE FOUNDERS COMPANY**

36 POINT

8 A 14 a \$7 40

INTERESTING  
Guaranteed Securities

28 POINT

10 A 20 a \$7 20

GREAT BORES  
Tunnels through Hoosac

22 POINT

14 A 25 a \$6 15

SLEIGH RIDING  
Invigorating and Exhilarating

18 POINT

16 A 32 a \$5 50

GENEROUS PEOPLE  
Distributing Charity Unsparingly

12 POINT

22 A 42 a \$3 90

ROUGH-SHOD  
Jumping over Streams

10 POINT

30 A 52 a \$3 70

COMPLIMENTARY  
Third Annual Excursion

6 POINT

30 A 52 a \$3 45

PARENTAL PHYSIC  
Spring Woodshed Exercises  
1234567890

6 POINT

36 A 70 a \$3 20

MODERN LEGISLATION  
Protecting Corporation Monopolies  
1234567890

## Lightface Extended No 40

18 POINT

10A 14a \$5 20

# MINISTERS

## Prominent Preachers

12 POINT

18A 20a \$4 55

**CHIME**  
Sweet Sounds

8 POINT

36A 32a \$4 35

**PROMISING**  
Corpulent Aldermanic  
Candidates

5½ POINT

36A 70a \$4 30

**DOCTOR HELPEMUP**  
Gout Destroyer and Exterminator  
1234567890

10 POINT

25A 26a \$4 25

**STRONG**  
Energetic Mortals

6 POINT

36A 42a \$3 75

**LENGTHENING**  
Declining Evening Shadows  
Solemn Scenes

5 POINT

36A 70a \$4 85

**DWARF HEROINES**  
Imported Dime Museum Freaks  
1234567890

## Title Extended No 42

18 POINT

10A 14a \$4 15

**PRESS**  
Typography

10 POINT

25A 26a \$4 25

**IMMENSE**  
Untamed Animals

6 POINT

36A 42a \$3 85

**LILLIPUTIANS**  
Dumpty Representatives  
1234567890

12 POINT

18A 20a \$4 20

**TRICKS**  
Grave Juggler

6 POINT

36A 32a \$4 40

**NEWSMEN**  
Garrulous Neighbors

5½ POINT

36A 42a \$4 05

**MATRIMONIAL**  
Happy and Contented Infant  
1234567890

AMERICAN TYPE FOUNDERS COMPANY

Antique Series

44 POINT NO 45

5 A 7 a \$12 50

# Mince PIES

36 POINT NO 45

7 A 10 a \$9 00

# Old RIO Coffee

28 POINT NO 45

7 A 14 a \$7 55

# Pleasant DINNER

24 POINT NO 45

10 A 20 a \$8 30

# LIQUID Rum Punch

18 POINT NO 45

16 A 28 a \$5 80

# PUDDING Cereal Dessert

12 POINT NO 45

25 A 32 a \$4 20

# REFRESHING Ice Cream with Toast

10 POINT NO 45

36 A 52 a \$4 05

# RICH PROVENDER Kidneys Rolled in Sawdust

9 POINT NO 45

36 A 70 e \$4 10

# PRECIOUS TIDBITS Cock's Comb with Flea Sauce Panned Oysters

8 POINT NO 45

36 A 70 a \$3 80

# VEGETABLE COURSE Buttered Squash, Bottled Beans Stewed Tomatoes

6 POINT NO 15

36 A 70 a \$3 52

BOSTON PUBLIC LIBRARY  
Thousands of Visitors Admiring this  
Grand and Famous Structure  
1234567890

5 1/2 POINT NO 45

36 A 70 a \$2 95

ALL KINDS OF GAME IN SEASON  
Reed Birds, Quail on Toast, Stewed Terrapin  
Rabbit, Venison, Wild Duck  
1234567890

AMERICAN TYPE FOUNDERS COMPANY



**Antique Series**

8-c

48 POINT NO 44

7 A 10 a \$16 15

**GOLD Mine**

44 POINT NO 44

7 A 10 a \$12 10

**Minute GUNS**

36 POINT NO 33

6 A 12 a \$7 40

**FREE Noble Heart**

28 POINT NO 44

10 A 20 a \$7 70

**BRISK  
High Wind**

16 POINT NO 44

16 A 26 a \$5 30

**BENDING  
Stubborn Youth**

10 POINT NO 44

36 A 52 a \$4 40

**MUSTERING  
Regimental Conscription**

6 POINT NO 44

36 A 70 a \$3 35

**CONDENSING PROCESS  
Perspiring and Sweltering Humanity  
1234567890**

22 POINT NO 44

14 A 20 a \$5 70

**CLIPPED  
Noble Horses**

12 POINT NO 44

25 A 32 a \$4 30

**DECLINING  
Steamboat Securities**

8 POINT NO 44

36 A 70 a \$4 05

**THUNDER STORMS  
Relief to Sweltering Humanity**

5 POINT NO 44

36 A 70 a \$3 15

**IMPROVED SHOEMAKING  
Dainty Footwear for Fashionable Promenaders  
1234567890**

**AMERICAN TYPE FOUNDERS COMPANY**

48 POINT

4 A 6a \$8 90

**RICH Lands**

40 POINT

5 A 8a \$7 00

**Liberal TERM**

38 POINT

8 A 10a \$8 90

**PRODUCTS**  
**Siberian Diamonds**

28 POINT

8 A 12a \$5 30

**SHIPS**  
**Cool Trips**

22 POINT

10 A 15a \$4 05

**SILENT**  
**Prison Halls**

18 POINT

10 A 20a \$4 20

**INDIANA**  
**National Queen**

12 POINT

15 A 25a \$3 00

**REPRIMANDS**  
**Social Reformatons**

10 POINT

20 A 30a \$2 60

**SOCIAL LEADERS**  
**Great Annual Horse Show**

8 POINT

30 A 50a \$3 15

**FASHION EXHIBITION**  
**Grand Display of Gotham Beauty**

6 POINT

30 A 50a \$2 90

**BRILLIANT DECORATION**  
**Blue Ribbon Parade of Blooded Steeds**  
1234567890

5 POINT

40 A 75a \$3 05

**ANNUAL CALEDONIAN GAMES**  
**Rosy Cheeked Maids in the Matrimonial Race**  
1234567890

48 POINT

5 A 7 a \$11 10

**OUTCRY**  
**Infant Alarm**

40 POINT

7 A 10 a \$9 30

**MORNING**  
**Sunshine Baths**

38 POINT

10 A 14 a \$10 05

**ECHO**  
**Answers**

20 POINT

10 A 14 a \$4 75

**SOUND**  
**Instruction**

16 POINT

14 A 14 a \$3 95

**REPOSE**  
**Quiet Homes**

12 POINT

18 A 20 a \$3 50

**COLDNIP**  
**Red Nose Painter**

6 POINT

36 A 42 a \$4 45

**GULLIBLENESS**  
**Flowing Wells Assured**  
**12345678**

6 POINT

36 A 52 a \$3 35

**UNSUSPICIOUSNESS**  
**Sweet Jersey Limburger Bologna**  
**1234567890**

## Antique No 46

36 POINT

10 A 14 a \$9 00

**TABLE**  
**Indulgent**

18 POINT

18 A 28 a \$4 80

**WORKERS**  
**Fleeced for Drones**

10 POINT

38 A 52 a \$3 80

**ANGRY CLIENTS**  
**One-sided Decisions Prepared**

8 POINT

38 A 70 a \$3 05

**STREET-SWEEPING MACHINES**  
**Treasuries Swept Clean of Filthy Lucre**  
12 34567890

24 POINT

10 A 20 a \$5 50

**COMFORT**  
**Love Children**

12 POINT

25 A 32 a \$3 55

**STREET SCENE**  
**Snow-covered Boulevard**

8 POINT

38 A 70 a \$3 50

**CORRUPTED POLITICS**  
**Mercenary Politicians Purchasable**

5½ POINT

38 A 70 a \$2 50

**MAGNIFICENT AMERICAN DOMAINS**  
**Transferred into the Pockets of Railway Companies**  
1 234567890

## Antique Condensed No 44

28 POINT

12 A 18 a \$5 80

**DANGEROUS** **Traveler Returned**

22 POINT

18 A 25 a \$5 40

**Passenger TRAIN**

18 POINT

18 A 28 a \$3 95

**Locomotive RESUME**

14 POINT

22 A 42 a \$3 80

**MEDITATIONS**  
**Wounded Heads Dressed**

12 POINT

22 A 42 a \$3 15

**LAUGHING-STOCK**  
**On-lookers Turn and Tumble**

10 POINT

30 A 52 a \$3 15

**SLEEPER'S TRIBULATION**  
**Emerges with Shirt Over Head**  
1234567890

8 POINT

36 A 52 a \$2 85

**EXCURSIONISTS' DILEMMA**  
**Baggage Exchanged, Everything Wrong**  
1234567890

AMERICAN TYPE FOUNDERS COMPANY

Antique Condensed No 46

72 POINT

5 A \$6 35

**PLUM CIDER**

60 POINT

7 A \$7 90

**IMPONDERABLE**

48 POINT

7 A \$5 85

**CUSHION**

44 POINT

10 A \$5 65

**SPENDING**

40 POINT

10 A \$4 25

**FINISHERS**

36 POINT

10 A \$3 35

**LUMBERMEN**

28 POINT

14 A \$3 45

**DISINGENUOUS**

24 POINT

18 A \$3 40

**CONTRADICTION**

22 POINT

16 A \$2 65

**PREDETERMINED**

20 POINT

22 A \$2 90

**EXTEMPORANEOUS**

16 POINT

25 A \$2 40

**AMERICAN MECHANICS**

12 POINT

36 A \$2 35

**ESTABLISHED FURNISHERS**

AMERICAN TYPE FOUNDERS COMPANY

**Antique Condensed No 45**

60 POINT

7 A 7 a \$16 10

**Curious BIRDS**

46 POINT

7 A 10 a \$14 75

**ICE Man**

44 POINT

7 A 10 a \$9 40

**OLD Hens**

36 POINT

10 A 14 a \$7 05

**STORM  
High Winds**

26 POINT

14 A 20 a \$7 35

**QUININE  
Sample Boxes**

22 POINT

16 A 26 a \$6 25

**MUSEUM  
Chinese Carvings**

18 POINT

22 A 26 a \$4 70

**REVIEWERS  
Magazine Editorials**

12 POINT

25 A 42 a \$3 95

**CULINASTICS  
Delicious Kitchen Product**

10 POINT

36 A 52 a \$3 60

**MORNING EXERCISE  
Breakfast Table Manipulations**

6 POINT

36 A 70 a \$3 40

**SHOUTERS' HANDBOOK  
Slangwhang Lecturers' Encyclopædia  
1234567890**

6 POINT

52 A 70 a \$3 10

**WHOLESALE INFANTICIDE  
Recipes for Destroying Infantile Constitutions  
1234567890**

**AMERICAN TYPE FOUNDERS COMPANY**

Antique Extra Condensed No 42

72 POINT

4 A 7 a \$9 00

Obstruction REMOVED

60 POINT

6 A 10 a \$8 40

RESPECTING Householders

48 POINT

8 A 12 a \$8 10

Desired FENCE

36 POINT

9 A 15 a \$7 50

Machine BROKE

28 POINT

12 A 20 a \$7 10

COMMITTEE  
Weekly Examination

22 POINT

16 A 28 a \$5 40

MISMANAGEMENT  
Advantages are Overthrown

18 POINT

16 A 32 a \$4 80

PROPHETIC EXPERTS  
Mantology Premonstration Society

12 POINT

25 A 42 a \$4 60

LIBERAL FAIR MAIDENS  
Bachelors Wanted to Matrimonialize

10 POINT

36 A 52 a \$4 40

ELASTIC ANTI-FRICTION MORALS  
Giving Great Sinners the Semblance of Saints  
1234567890

8 POINT

36 A 70 a \$4 00

MUNICIPALITIES UTILIZING CORPORATIONS  
Honesty on a Basis of Law and not upon Principle  
1234567890

AMERICAN TYPE FOUNDERS COMPANY

48 POINT NO 32

4 A 8a \$7 50

# SUN Shadows

40 POINT NO 30

5 A 8a \$5 00

# Mechanic UNITED

28 POINT NO 40

10 A 14a \$6 00

## FOND Simon

22 POINT NO 40

14 A 20a \$5 10

## EXACT Policies

20 POINT NO 40

18 A 28a \$5 15

## PROPHETS Shadowing Comets

14 POINT NO 40

22 A 32a \$4 15

## ACCOMMODATE Afford Home Comfort

12 POINT NO 40

22 A 32a \$3 90

## APARTMENTS Mean Terms Desired

11 POINT NO 40

38 A 70a \$4 75

## COOLING BEDROOM Summer Comfort for Guests

10 POINT NO 40

38 A 70a \$4 80

## OPPORTUNITIES Fire Insurance Companies

9 POINT NO 40

38 A 70a \$3 50

## FUNDING OPERATION Gigantic Cumulation of Securities

8 POINT NO 40

38 A 70a \$3 80

## EXCELLENT CHANCES Tired People Forming a Company

7 POINT NO 40

38 A 70a \$3 10

## SECURITY UNLIMITED Eighty-Nine Thousand Dollars Required

8 POINT NO 40

38 A 70a \$2 85

## UNEARNED FORTUNES Wealth Speedily Acquired by Purchasing 1234567890

5 POINT NO 40

38 A 70a \$3 50

## INESTIMABLE BLESSING Daybreak Invigorator for Promoting Appetites 1234567890



60 POINT NO 10

3 A 4a \$9 88

Latest **CARD**

48 POINT NO 40

7 A 10a \$12 10

**FIRM** Husbands

40 POINT NO 40

7 A 10a \$7 00

Comfortable **SHINE**

36 POINT NO 40

10 A 14a \$7 25

**TROOPS** Help Your Host

28 POINT NO 40

14 A 20a \$7 25

**FRUGAL**  
Elderly Aunts

18 POINT NO 40

22 A 28a \$4 35

**GOFFERING**  
Imported Trimmings

12 POINT NO 40

25 A 42a \$3 70

**SPIRIT WORLD**  
Primary School Instruction  
1234567890

22 POINT NO 40

18 A 28a \$5 85

**INFANTS**  
Future Presidents

14 POINT NO 40

25 A 42a \$4 25

**WORTHLESS**  
Improvident Spendthrift

10 POINT NO 40

38 A 52a \$3 10

**FRIVOLOUS NOTION**  
Fashionable Street Promenadings  
1234567890

Antique Extended No 40

48 POINT

3 A 4 a \$19 80

**Band**

32 POINT

3 A 4 a \$9 70

**Prime**

26 POINT

5 A 6 a \$8 45

**FINE  
Hot Buns**

20 POINT

7 A 10 a \$5 95

**UNITED  
Man and Wife**

12 POINT

14 A 14 a \$5 20

**LUSCIOUS  
Bunches of Grapes**

10 POINT

14 A 20 a \$4 00

**STERN  
Musketeers**

6 POINT

22 A 26 a \$4 75

**MONEY  
Heavy Purses**

6 POINT

22 A 26 a \$3 60

**SETTLERS  
Farmer Emigrants  
12345678**

5 POINT

36 A 42 a \$5 10

**THUMB & NUT  
Millionaire Lilliputianists  
12345678**

AMERICAN TYPE FOUNDERS COMPANY

## Antique Extended No 45

28 POINT

5 A \$4 20

# PRETEND

24 POINT

5 A \$3 15

# MINISTERS

20 POINT

7 A \$2 70

# BRICK HOUSE

16 POINT

10 A \$2 65

# STORMS

12 POINT

18 A \$2 95

# COMBINES

10 POINT

25 A \$2 60

# SUBTRACTION

8 POINT

36 A \$2 90

# WINTER JOLLITY

6 POINT

36 A \$2 40

# MOONLIT EXPANSE

1 2 3 4 5 6 7 8 9 0

5 POINT

36 A \$2 65

# GUSHING STREAMLETS

1 2 3 4 5 6 7 8 9 0

## Antique Extended

12 POINT No 44

18 A \$3 00

# COMPOSED

10 POINT No 44

25 A \$2 90

# SHEEPSKINS

8 POINT No 44

36 A \$3 35

# COURT-HOUSES

6 POINT No 44

36 A \$2 75

# CHARITY HOTELS

5 POINT No 44

36 A \$2 45

# PAWNBROKERS LOCKUP AND HOLDFAST

1 2 3 4 5 6 7 8 9 0

5 POINT No 43

36 A \$2 25

# MODERN GOWNS EXPERT STREET CLEANERS

1 2 3 4 5 6 7 8 9 0

AMERICAN TYPE FOUNDERS COMPANY

# Lining Antique Series

36 POINT NO 40

6A \$4 50

# CHECKERED

30 POINT NO 40

6A \$3 80

# PREMIERSHIPS

24 POINT NO 40

10A \$3 20

# STATION

18 POINT NO 40

14A \$2 55

# COMPOUND

12 POINT NO 40

25A \$2 25

# HEALTHY SMILING FACES

10 POINT NO 40

30A \$2 00

# EXCURSION LARGE STEAMSHIP

8 POINT NO 40

36A \$2 00

# FAMILY ACROBATS PITCHER AND TUMBLER

8 POINT NO 45

45A \$1 90

# ANNUAL GATHERING MUTUAL ADMIRATION SOCIETY

8 POINT NO 44

45A \$1 60

# LIBERAL COMPENSATION ALLOWED FOR ADVERTISING SURFACE FENCES PREFERRED

8 POINT NO 43

45A \$1 30

# APPROACHING DESTINATION AGED VETERANS IN THE WARFARE OF LIFE CONTENTED TRAVELERS

6 POINT NO 42

45A \$1 15

# INDUSTRIAL DEPARTMENT EMPLOYING BUSY BRAINS AND ACTIVE MUSCLES IMPROVED TOOLS AND IMPLEMENTS

1234567890

6 POINT NO 41

45A \$1 10

# NOTEWORTHY OCCURRENCES MATRIMONIAL VOWS AND ADVENT OF THE FIRST-BORN SUMMER VISITS TO COUNTRY COUSINS

1234567890

# HHHHHHHHH NNNNNNNNN

AMERICAN TYPE FOUNDERS COMPANY

## Combination Gothic

— D E —

24 POINT NO 120

6 A \$2 00

# HUNTER SPEAKING

24 POINT NO 119

6 A \$2 00

# DESIRABLE HUCKSTER

18 POINT NO 118

8 A \$2 00

# HONEST MACHINE BUILDER

18 POINT NO 117

10 A \$2 00

## NOVEL HEROES

12 POINT NO 116

12 A \$1 50

## FRENCH SHADE

12 POINT NO 115

14 A \$1 50

## COUNCILMEN SENDING NOTICES

12 POINT NO 114

18 A \$1 50

## WESTERN FARMS PROVIDE MANY HOMES

6 POINT NO 113

32 A \$1 50

## BOWLERS ORGANIZED ANXIOUS PUGILISTIC TRAINING

6 POINT NO 112

32 A \$1 50

## SPORTINGMEN GATHERING SOUTHERN DELEGATES PRESENT

6 POINT NO 111

36 A \$1 25

## WASHINGTON MONUMENT SOCIETY PEOPLE BEING WISELY TAUGHT 1 2 3 4 5 6 7 8 9 0

6 POINT NO 110

36 A \$1 25

## THEATRICAL MANAGERS HUSTLING STRIKING MUSICIANS PREVENT PERFORMANCE 1 2 3 4 5 6 7 8 9 0

## Lining Gothic

— E —

6 POINT NO 34

60 A \$2 25

## PROFESSIONAL TREATMENT MAY NECESSITATE SOME PAIN

6 POINT NO 33

60 A \$2 25

## HORRORS ACCUMULATE WHEN YOUTHFUL SURGEONS PROBE THE CRUEL SORE

6 POINT NO 32

60 A \$2 25

## PERSEVERANCE MAY NOT BRING THE REWARD YOU SEEK, BUT CONSCIENCE APPROVES THE DUTY DONE \$ 1 2 3 4 5 6 7 8 9 0

6 POINT NO 31

60 A \$2 25

## SHOULD FORTUNE NEVER TARRY AT YOUR GATE, BE STILL AND MURMUR NOT; RATHER LEARN TO LABOR AND TO WAIT \$ 1 2 3 4 5 6 7 8 9 0

COMPLETE SERIES (FOUR FONTS) \$8 00

AMERICAN TYPE FOUNDERS COMPANY

## Combination Gothic

12 POINT NO 19

14 A \$1 50

MAGNIFICENT SACRED PANORAMIC EXHIBITS

12 POINT NO 16

16 A \$1 50

BARNSTORMING  
BREAKING CONTRACT

12 POINT NO 17

16 A \$1 25

ORDERING WARSHIPS  
STRONG VETERANS MARCH

12 POINT NO 16

24 A \$1 25

MERCHANTS COMPLAIN  
BANKING FAILURES REPORTED

6 POINT NO 15

30 A \$1 50

TROUBLESOME MACHINERY  
MECHANICAL DISCOVERY DOUBTED

6 POINT NO 14

40 A \$1 50

UNVEILING MEMORIAL STATUES  
THOUSANDS ATTEND SOLEMN CEREMONIES

6 POINT NO 13

40 A \$1 50

WEALTHIEST AMERICAN ENTERPRISE  
EXPORTING VARIOUS ARTICLES MANUFACTURED

6 POINT NO 12

50 A \$1 25

WONDERFUL AUSTRALIAN ACROBATIC PERFORMER  
ASTONISHING FEAT BROUGHT FORTH THUNDERING APPLAUSE

1 2 3 4 5 6 7 8 8 0

6 POINT NO 11

50 A \$1 25

GERMAN SING AG VEREINS ENJOYING DRAMAS  
OKLAHOMA COWBOY DESPERADO RELIEVING NUMEROUS PASSENGERS

1 2 3 4 5 6 7 8 9 0

## Combination Condensed Gothic

12 POINT NO 166

16 A \$1 50

RESIDENTS ANTICIPATING THE FORMATION OF YACHTING ORGANIZATIONS

12 POINT NO 165

16 A \$1 25

SERENADERS WERE GATHERING NEAR THE HOUSE WHEN THE COLONELS RESPOND

12 POINT NO 164

24 A \$1 25

LECTURING UNDER DIFFICULTIES  
SPEAKERS HDARSE AND AUDIENCE FROZEN

6 POINT NO 163

32 A \$1 50

COURAGEOUS COMPOSITOR TRAMPERS  
SEVERAL DELIGHTFUL MEDICAL DISCOVERIES PERFORMED

6 POINT NO 162

40 A \$1 25

SCHEDULED RAILROAD TRAINS WRECKED  
DELAYING FDREIGN FREIGHT NEARLY TWELVE MDNTHS  
1 2 3 4 5 6 7 8 9 0

6 POINT NO 161

50 A \$1 25

MOUNTAIN CLIMBING GREATLY ENJOYED  
SOUTHERN CLIMATE SOUGHT OURING SEVERE COLO WEATHER  
1 2 3 4 5 6 7 8 9 0

AMERICAN TYPE FOUNDERS COMPANY

## Gothic Condensed No 112

24 POINT

12 A 20 a \$3 75

BROTHER DANCES Blackface Specialties

18 POINT

16 A 24 a \$3 20

Unexpected Combination BROUGHT BRACKETS

12 POINT

24 A 36 a \$3 08

BREAKERS LOWERING WHALING CREWS  
Thornton Anniversary Receptions and Operatic Entertainments

10 POINT

28 A 44 a \$2 50

SELECTING SHOPLIFTER  
Watches and Precious Stones Taken  
1 2 3 4 5 6 7 8 9 0

8 POINT

40 A 62 a \$2 70

RENOWNED LITERARY PERSON  
Prominent Writers Hesitate Sending Articles  
1 2 3 4 5 6 7 8 9 0

## Gothic Condensed No 46

36 POINT

10 A \$4 95

FASTIDIOUS DAMSELS

28 POINT

14 A \$3 45

BEWILDERED

20 POINT

22 A \$2 95

SUPERIOR CHEESE

18 POINT

25 A \$2 80

IMPORTED CHAMPAGNE

12 POINT

36 A \$1 90

BENEFICIAL CONSIDERATIONS

10 POINT

38 A \$1 50

ECONOMICAL STATE CONVENTIONS

8 POINT

45 A \$1 50

CHINESE COOLIES IN DISGUISE NOT WANTED

6 POINT

52 A \$1 40

HOME COMFORTS ABOLISHED AND MEALS TAKEN OUT  
1 2 3 4 5 6 7 8 9 0

8 POINT No 41

52 A \$1 25

WOMEN'S RIGHT TO SOVEREIGNTY IN AFFECTION ABNEGATED  
1 2 3 4 5 6 7 8 9 0

AMERICAN TYPE FOUNDERS COMPANY

**Gothic Condensed No 127**

48 POINT

4 A \$3 00

**MADISON RECORDER**

40 POINT

5 A \$2 40

**HUNTERS 56 MOUNTED**

32 POINT

8 A \$2 45

**DENVERS SQUARE GARDENS**

28 POINT

10 A \$2 30

**MATHEMATICS**

24 POINT

12 A \$2 15

**DEMONSTRATIVE**

20 POINT

18 A \$2 10

**DENTAL 45 PARLOR**

18 POINT

18 A \$1 90

**HUMANE 68 BELOVED**

16 POINT

24 A \$1 95

**POPULATION INCREASING**

12 POINT

32 A \$1 80

**BEAUTIFUL FLOWER GARDENS**

10 POINT

38 A \$1 40

**NUMEROUS EXPERIENCED TRADESMEN  
REPORTED 546 SWINDLED**

8 POINT

42 A \$1 35

**BRIBERY CHARGES CONCERNING PROMINENT  
GOVERNMENT 45678 OFFICIALS**

8 POINT

48 A \$1 25

**KNOWING THAT THE HUMAN HAND IF INTELLIGENTLY  
EDUCATED AND SKILLFULLY EMPLOYED**

5 POINT ON 8 POINT

58 A \$1 30

**THIS INTELLIGENT COMBINATION OF RECENT IMPROVEMENTS  
PRESENTED FOR FURTHER CONSIDERATION**

**AMERICAN TYPE FOUNDERS COMPANY**



Chamfer Condensed

72 POINT

7 A \$9 90

COMPREHENSIVE

60 POINT

7 A \$7 15

PEACH DUMPLINGS

48 POINT

7 A \$6 15

PROMOTER

40 POINT

10 A \$4 90

PRESUMPTIVE

36 POINT

10 A \$3 75

GARDEN HOMES

28 POINT

14 A \$4 00

THREE PRECINCTS

22 POINT

16 A \$3 00

REMEDIES FOR CHOLERA

16 POINT

30 A \$3 60

HIGHPRICE AND POORPANTRY

12 POINT

36 A \$2 60

CAREFUL HABITS AND GOOD INTENTION

10 POINT

36 A \$2 00

SMALL MEASURE AND MUCH LIGHTER WEIGHT

6 POINT

45 A \$2 00

CHURCHDOOR LOUNGER AND STEADY CORNER-LOAFER  
1234567890

6 POINT

52 A \$2 00

PROFESSOR HERBATHER'S PROGRESSIVE SYSTEM OF EXTRACTING  
1234567890

84 and 96 Point of this Series also furnished

AMERICAN TYPE FOUNDERS COMPANY

## Johnson Gothic

16 POINT

16 A 24 a \$4 00

GENTLEMEN ESTABLISHED  
Automatic Millionaire Purchasing Securities

14 POINT

14 A 36 a \$3 75

STIRRING POLITICAL SPEECHES  
Wonderous Adventures in King Solomon's Mines

12 POINT

15 A 40 a \$3 50

SERIES FURNISHED  
Cheaper Refreshment Ticket

10 POINT

16 A 45 a \$3 00

MAGNIFICENT YACHT  
Trained Animals for Performances

8 POINT

20 A 50 a \$2 50

NUMEROUS REQUESTS  
Beautiful Productions from Flowers  
1234567890

6 POINT

24 A 60 a \$2 25

COMMERCIAL ADVERTISER  
Unavoidable and Laughable Adventures  
1234567890

## Gothic No 47

24 POINT

10 A 14 a \$5 30

MUNIFICENT Donations

16 POINT

14 A 25 a \$3 60

RIDICULOUS ASSERTIONS  
Seafaring Adventurers Discover Fortunes

12 POINT

25 A 42 a \$3 35

CHOICE STEAKS  
Daintiest and Choicest Cuts

10 POINT

36 A 70 a \$3 40

ENGAGING NOTHINGS  
Small Talk and Trivial Associations

6 POINT

36 A 70 a \$2 75

GEORGIANA RUBHARD  
First Water Operative with Soap Odoriferous  
1234567890

6 POINT

52 A 70 a \$2 65

BRIDGET MACDUMPLING  
Will Accept a Nice Situation in a Genteel Family  
1234567890

AMERICAN TYPE FOUNDERS COMPANY

# Lining Gothic No 43

36 POINT

6 A 9 a \$7 10

# FATAL Combats

30 POINT

6 A 12 a \$6 60

# Headmost BEAUS

24 POINT

10 A 15 a \$5 20

# MODERN Homestead

16 POINT

14 A 25 a \$4 95

# Guide HOME

12 POINT

25 A 40 a \$4 20

# SKYHIGH Reviews

9 POINT

36 A 50 a \$3 90

# UNCOMBINED Improved Roofing Material

6 POINT

36 A 55 a \$3 90

# ADVANCEMENT Sunshine of Prosperous Days

6 POINT NO 417

60 A 70 a \$4 00

# CELESTIAL HEMISPHERE Inclinations of Base with the Horizon

6 POINT NO 416 C and 1 c

60 A 70 a \$3 70

# MICROSCOPIC INDICATIONS Calculations made by Illustrious Astronomers

6 POINT NO 415

60 A \$2 25

# INACCURATE GEODETIC OPERATIONS DOUBTFUL CIRCUMFERENCE OF THE TERRESTRIAL SPHERE

1 2 3 4 5 6 7 8 8 0

6 POINT NO 414

60 A \$2 25

# TRIANGULATION OF THE MERIDIAN SUPERIORITY OF THE MODERN INSTRUMENTS FOR MEASUREMENT

1 2 3 4 5 6 7 8 9 0

mmmmmmmmmm HHHHHHHH

AMERICAN TYPE FOUNDERS COMPANY

Lining Gothic No 44

36 POINT

6 A 8 a \$7 65

STATE Burden

30 POINT

8 A 12 a \$6 95

Mounted SHEIKS

24 POINT

10 A 15 a \$5 65

TRAINED Elephants

18 POINT

14 A 22 a \$4 75

Emancipated PATAGONIAN

12 POINT

22 A 40 a \$4 10

ASCENDING  
Beautiful Pathways

10 POINT

28 A 45 a \$4 05

TOURISTS  
Discover Ancient Ruins

6 POINT

36 A 55 a \$3 80

RECONSTRUCTING  
Stringent Fireside Regulation

6 POINT No 422

50 A 70 a \$4 45

SOCIAL GATHERINGS  
Harmony and Sunshine Displayed

6 POINT No 421

50 A \$2 35

GENDARMES SUMMONED  
LIGHTFINGER'S BRIGANDS TAKEN

6 POINT No 420

50 A \$1 70

MOONSTRUCK BURGLARS  
SLEIGHS BROUGHT INTO REQUISITION

6 POINT No 419

50 A \$1 40

POLICEMEN HUNTING INVADERS  
ANGRY HOUSEWIVES OVERHAULING BUREAUS  
1234567890

6 POINT No 418

50 A \$1 35

CARELESS BOLTING OF FRONT DOORS  
RECOMMENDED BY PROFESSOR LIGHTFINGER  
1234567890

mmmmmmmmmm HHHHHHHH

AMERICAN TYPE FOUNDERS COMPANY

# Lining Gothic No 45

36 POINT

4 A 7 a \$6 80

# FINE Singers

30 POINT

6 A 9 a \$6 35

# Morning DAWN

24 POINT

6 A 12 a \$5 20

# HEROIC Adventure

18 POINT

12 A 18 a \$4 45

# Roving FOREIGN Waters

12 POINT

20 A 30 a \$4 00

## GRECIAN Damsels Adopted

9 POINT

25 A 45 a \$3 65

## HUNTSMEN Spinning Fishing Yarns

8 POINT

36 A 55 a \$3 60

## ROYSTERING Juveniles Charm and Delight

6 POINT No 427

45 A 70 a \$4 45

## LIBERAL PENSION Decrepit Old Ringsters Disturbed

6 POINT No 426

45 A \$2 10

## MASTERLY RETREAT STRUGGLES AGAINST DESTINY

6 POINT No 425

45 A \$1 90

## SCENES AND INCIDENTS DINNER-TIME AMONG INSURGENTS

6 POINT No 424

45 A \$1 55

## BOILING GEYSER WATER ABANDONMENT OF FUEL FOR STEAM-POWER 1 2 3 4 5 6 7 8 9 0

6 POINT No 423

45 A \$1 45

## RESOLUTIONS ON WARFARE ARMIES MUST NOT EXCEED FOUR HUNDRED MEN 1 2 3 4 5 6 7 8 9 0

# mmmmmmmmmm NNNNNN

AMERICAN TYPE FOUNDERS COMPANY











Philadelphia Lining Gothic

48 POINT NO 948

5 A 7 a \$8 50

WAVE Depart

36 POINT NO 938

8 A 9 a \$7 00

Northern HOME

30 POINT NO 930

8 A 10 a \$8 00

PATRIOT Embarked

24 POINT NO 924

12 A 18 a \$5 25

Advertisement PRINTED

18 POINT NO 918

14 A 22 a \$4 75

PAINTED  
Winter Scene

14 POINT NO 914

20 A 30 a \$4 50

MODERN  
Design Admired

12 POINT NO 912

25 A 38 a \$4 25

REGIMENT  
Mountain Fortress

10 POINT NO 910

30 A 45 a \$4 00

REDUCTIONS  
During Holiday Season

8 POINT NO 908

38 A 50 a \$3 75

TRANSPORTATION  
Declined by Foreign Visitor  
1 2 3 4 5 6 7 8 9 0

8 POINT NO 908

40 A 50 a \$3 50

COMPANIES ORGANIZED  
Frolics Beneath a Starry Heaven  
1 2 3 4 5 6 7 8 9 0

MMMMMMMMMMMM  
mmmmmmmmmmmmmm



Philadelphia Lining Gothic

48 POINT No 1248

4 A 5 a \$9 25

DIN Heard

36 POINT No 1238

5 A 7 a \$7 75

Noted MEN

30 POINT No 1230

8 A 9 a \$8 50

SHOE Marked

24 POINT No 1224

9 A 12 a \$5 50

Damaged BENCH

18 POINT No 1218

12 A 15 a \$5 00

MATCH  
Burn Cord

14 POINT No 1214

14 A 22 a \$4 75

MUSING  
Comic Song

12 POINT No 1212

18 A 28 a \$4 50

NOISOME  
Martial Sound

10 POINT No 1210

22 A 35 a \$4 25

REPORTS  
Sporting Writers

8 POINT No 1208

28 A 42 a \$4 00

INSTRUCTIONS  
Educated Mechanics  
1 2 3 4 5 6 7 8

8 POINT No 1206

30 A 45 a \$3 75

CONGREGATION  
Delighted with Sermons  
1 2 3 4 5 6 7 8 9 0

NNNNNNNNNNNN  
nnnnnnnnnnnn

AMERICAN TYPE FOUNDERS COMPANY

**Philadelphia Lining Gothic**

48 POINT No 1348

3 A 4 a \$10 00

**SIX Bats**

36 POINT No 1338

4 A 6 a \$8 50

**New SITE**

30 POINT No 1330

6 A 8 a \$7 00

**MAY Parties**

24 POINT No 1324

7 A 12 a \$6 00

**Electric SHOCK**

18 POINT No 1318

10 A 14 a \$5 25

**GLIDE  
Fast Tide**

14 POINT No 1314

14 A 22 a \$5 00

**STRING  
Lyric Poet**

12 POINT No 1312

16 A 28 a \$4 75

**BALSAM  
Doctor Right**

10 POINT No 1310

20 A 35 a \$4 50

**PARKSIDE  
Natural Scenes**

8 POINT No 1308

25 A 40 a \$4 25

**BIOGRAPHER  
Historical Writings  
123456789**

6 POINT No 1306

26 A 40 a \$4 00

**FASCINATION  
Prodigious Magicians  
123456789**

**NNNNNNNNNNNN  
nnnnnnnnnnnn**

AMERICAN TYPE FOUNDERS COMPANY

Philadelphia Lining Gothic

48 POINT No 1446

3A 5a \$11 25

**NO Rain**

36 POINT No 1436

5A 7a \$9 75

**Mark VAT**

30 POINT No 1430

6A 9a \$8 25

**TAKE Pains**

24 POINT No 1424

9A 12a \$7 00

**Steam WATCH**

18 POINT No 1418

12A 15a \$6 00

**PAST  
Fine Site**

14 POINT No 1414

15A 22a \$5 50

**WORN  
Gold Rope**

12 POINT No 1412

16A 26a \$5 00

**DEPART  
Slow Trains**

10 POINT No 1410

22A 32a \$4 75

**PARDON  
Honest People**

6 POINT No 1408

25A 40a \$4 50

**DESIRABLE  
Beautiful Designs  
1234567**

6 POINT No 1406

28A 45a \$4 25

**GUARDSMEN  
Exhausted Regiment  
12345678**

**NNNNNNNNNN  
nnnnnnnnnn**

Lining Gothic Extended No 40

36 POINT

4 A 6 a \$7 10

**FAST Race**

30 POINT

5 A 7 a \$5 15

**Beau MONDE**

24 POINT

7 A 10 a \$4 50

**HARTFORD  
Pleasure Steamer**

18 POINT

10 A 14 a \$4 30

**FAMILY GROUPS  
Basking in Sunbeams**

14 POINT

12 A 18 a \$3 50

**MODERN SAYINGS  
Phonographs Recharged**

12 POINT

14 A 22 a \$3 40

**DEMANDS  
Money Loans**

10 POINT

16 A 24 a \$3 10

**MONARCHS  
Create Blunders**

6 POINT

20 A 30 a \$3 00

**TEARQUICK  
Fashionable Gaskins  
1 2 3 4 5 6 7**

6 POINT

25 A 35 a \$3 00

**PREDETERMINE  
Eager Bargain Hunters  
1 2 3 4 5 6 7 8**

AMERICAN TYPE FOUNDERS COMPANY

**Gothic No 49**

72 POINT

4 A \$10 90

**OFFICE**

48 POINT

5 A \$7 20

**MIDNIGHT**

36 POINT

7 A \$4 15

**REASONS 325**

**Gothic No 48**

28 POINT

10 A 14 a \$7 10

**STUDENT Rewarding**

22 POINT

14 A 20 a \$5 75

**Plucky Submarine EXPLOIT**

18 POINT

18 A 28 a \$5 10

**DECISION  
Annual Dividend**

12 POINT

25 A 42 a \$4 40

**RESERVATION  
Gold-Fever Symptoms**

10 POINT

38 A 52 a \$4 05

**WORTH TESTING  
Wholesale Remonstrances  
12345678**

8 POINT

38 A 52 a \$3 50

**ROCKET CORPORATION  
Capitel Invested in Fast Horses  
12345678**



**Gothic No 16**

46 POINT

4A 5a \$10 00

**BAD Catch**

42 POINT

4A 5a \$7 75

**Stolen HARP**

36 POINT

4A 5a \$5 75

**GIRLS Dancing**

30 POINT

4A 6a \$5 80

**Lobsters FRESH**

24 POINT

6A 10a \$4 40

**RUN Slow**

20 POINT

6A 12a \$3 42

**STOP Breath**

16 POINT

12A 20a \$3 50

**Harming BEARS**

12 POINT

16A 24a \$3 42

**Diamond FIELDS**

10 POINT

16A 32a \$2 87

**STRIKE Undisturbed**

8 POINT

20A 40a \$2 98

**DISPOSING Merchandise**

7 POINT

20A 40a \$2 90

**POWERFUL MACHINES**  
**Experienced Mechanics Outdone**

6 POINT

24A 50a \$2 60

**RICHMOND VIRGINIA**  
**Delightful Southern Homesteads**

5½ POINT

36A 62a \$3 24

**LEADING HOLIDAY STYLES**  
**Great Multitudes Crowding the Stores**

5 POINT

24A 44a \$2 70

**PREACH TOUCHING SERMON**  
**Congregation Praising the Discourses**

**1 2 3 4 5 6 7 8 9 0**

**1 2 3 4 5 6 7 8 9 0**

AMERICAN TYPE FOUNDERS COMPANY

**Gothic Condensed No 37**

72 POINT

4 A \$8 20 4 A 8 a \$14 15

**MEN Count**

80 POINT

5 A \$8 50 5 A 8 a \$10 80

**Rulers HUNT**

48 POINT

8 A \$5 55 8 A 10 a \$9 75

**BIG Job**

40 POINT

8 A \$4 00 8 A 10 a \$8 90

**NO Home**

36 POINT

8 A \$3 75 8 A 12 a \$8 55

**TOSSED  
White Seas**

28 POINT

10 A \$2 95 10 A 15 a \$5 35

**WRECKED  
Sunk or Lost**

22 POINT

12 A \$2 50 12 A 8 A 20 a \$5 35

**IMPRISONED  
BURNT Demented**

18 POINT

15 A \$1 95 15 A 10 A 25 a \$4 20

**APPROPRIATION  
INTRODUCES Disasters**

12 POINT

20 A \$1 40 20 A 12 A 30 a \$3 00

**DESPERATE UNREST  
DEVITALIZES Developments  
1234567890**

10 POINT

25 A \$1 35 25 A 20 A 40 a \$3 15

**UNCONSIDERED ASSERTIONS  
VOLUNTEERED Without Conditions  
1234567890**

**Gothic Condensed No 36**

72 POINT

5 A \$7 15 5 A 3 a \$11 80

**RIFLE Stream**

60 POINT

5 A \$4 80 5 A 6 a \$7 90

**Crushed THUMB**

48 POINT

6 A \$4 05 6 A 10 a \$7 30

**BIG Mines**

40 POINT

10 A \$4 30 10 A 12 a \$7 00

**FINE Houses**

36 POINT

8 A \$2 80 8 A 12 a \$5 05

**MORNING  
Golden Clouds**

24 POINT

10 A \$1 80 10 A 15 a \$3 30

**BURDENSOME  
Business Tourists**

20 POINT

15 A \$1 80 15 A 10 A 20 a \$3 80

**HOME COMMERCE  
WHOLESALE Investments**

18 POINT

15 A \$1 30 15 A 10 A 25 a \$2 95

**MODERN VOLUNTEERS  
PATRIOTIC Arbitration Leaders**

12 POINT

20 A \$1 10 20 A 12 A 30 a \$2 40

**IMPORTANT EXPLORATION  
REGULAR Excursions to South Africa  
1234567890**

10 POINT

25 A \$1 10 25 A 20 A 40 a \$2 55

**WINTER HOME ENTERTAINMENT  
CHRISTMAS GAMES and Well-Filled Larder  
1234567890**

40 POINT

7 A 10 a \$5 90

**PROGRESSIVE**  
**Regular College Education**

28 POINT

14 A 20 a \$6 70

**AUTUMN FASHIONS**  
**Damsels with Beautiful Dresses**

22 POINT

18 A 28 a \$5 25

**COMPANIES ORGANIZED**  
**Insurance Against Trouble Guaranteed**

18 POINT

22 A 26 a \$4 55

**HOOPSKIRTS**  
**Shin Breaking Traps**

12 POINT

25 A 42 a \$3 35

**MONEY RECEIPTS**  
**Press and Signature Plates**

6 POINT

36 A 70 a \$3 25

**HEADBUMPER SKATING**  
**Acrobatic Tumbling and High Vaulting**  
1234567890

14 POINT

25 A 42 a \$4 05

**ELECTRIC BOOTS**  
**Keen Tonic for Sluggards**

10 POINT

36 A 52 a \$3 40

**YOUTHFUL DREAMS**  
**Boyhood Imaginings Dissipated**

6 POINT

52 A 70 a \$2 75

**ABUNDANT HARDHEADED TRUTHS**  
**Borne in Thoughtful Memories for Daily Service**  
1234567890

**Gothic Condensed No 44**

48 POINT

7 A 10 a \$10 75

**CHURNED Products**

44 POINT

7 A 10 a \$8 80

**Trained FROG Catcher**

36 POINT

10 A 14 a \$6 70

**PROFITS  
Earned Cash**

22 POINT

18 A 28 a \$5 40

**MUSICIANS  
Genteel Choristers**

12 POINT

25 A 42 a \$3 65

**ECONOMISTS  
Portmanteau Replenishers**

6 POINT

38 A 70 a \$3 10

**SENTIMENTAL ABSURDITY  
Domestic Service Made Dishonorable  
1234567890**

26 POINT

14 A 20 a \$6 80

**COMRADE  
Marine Gunner**

16 POINT

22 A 28 a \$4 35

**RECEPTIONS  
Midwinter Sponging**

10 POINT

36 A 52 a \$3 30

**CHARITY ENTERPRISE  
Corpulent Policemen Emaciated**

6 POINT

52 A 70 a \$2 80

**SKIMPOLE MUNDIVAGANT  
Devotes his Undivided Energies to the Friendless  
1234567890**

**AMERICAN TYPE FOUNDERS COMPANY**

84 POINT

5 A 7 a \$12 80

SPLENDID Societies

72 POINT

5 A 7 a \$11 35

Great CRIMINAL Trials

80 POINT

7 A 10 a \$10 40

HORSE Race

48 POINT

7 A 10 a \$8 70

Sacred MUSIC

40 POINT

10 A 14 a \$8 75

Famous WRITERS

38 POINT

14 A 20 a \$8 20

PROMINENT Printers

28 POINT

14 A 20 a \$8 05

ACCUMULATOR  
Trust Company Chartered

24 POINT

18 A 32 a \$8 80

COTTAGE CHARMS  
Happy and Obedient Children

18 POINT

25 A 42 a \$5 80

BUSINESS PROSPERITY  
Indefatigability and Contentedness  
1234567890

12 POINT

38 A 52 a \$4 00

STICKTOTRUTH AND KNOCKEMDOWN  
A Public Sale of Rare and Valuable Antique Goods  
1234567890

**Gothic Italic Extra Condensed**

42 POINT

8 A 10 a \$7 00

*CONTAMINATE Correspondents*

38 POINT

9 A 12 a \$8 00

*Blackened Character WHITEWASHED*

30 POINT

10 A 14 a \$5 00

*MEDDLESOME YOUTHS Lively Expert Players*

24 POINT

12 A 16 a \$4 25

*Characteristic Charities EARNESTLY PROTESTED*

20 POINT

15 A 20 a \$4 00

*TOOTHsome DELICACIES Devoured With Great Rapidity*

18 POINT

18 A 24 a \$3 75

*Numerous Selections From the VERY BEST STANDARD AUTHORS*

12 POINT

20 A 30 a \$3 40

*COLLECTING ANTIQUITIES  
Quaint and Curious Old Specimens*

10 POINT

24 A 36 a \$3 25

*PRINCELY SALARY PAID  
Superintendent Who has Responsibility*

8 POINT

28 A 38 a \$3 00

*SILVER MOON RESTAURANT  
A Famous Western Hostelry in Days Gone By  
1 2 3 4 5 6 7 8 9 0*

6 POINT

28 A 40 a \$2 50

*PECULIAR PRONUNCIATION CONDEMNED  
Plain Simple Style of Conversation Much More Preferable  
1 2 3 4 5 6 7 8 9 0*

AMERICAN TYPE FOUNDERS COMPANY

**Inclined Gothic Series**

24 POINT

8 A \$3 00

**JUBILEE SONG**

18 POINT

12 A \$2 50

**MUSICAL CHILDREN**

16 POINT

14 A \$2 25

**MASSACHUSETTS  
EDITORIAL ASSOCIATION**

12 POINT

20 A \$2 00

**FAMOUS STATESMEN  
ASSEMBLED IN CONFERENCE**

10 POINT

24 A \$1 75

**NUMEROUS PEOPLE  
WITNESS THE GRAND NAVAL DISPLAY**

8 POINT

26 A \$1 50

**EXTRAORDINARY ATTRACTION  
PERFORMING ELEPHANT BATHING IN RESERVOIR**

6 POINT No 7

26 A \$1 25

**MOUNT WASHINGTON  
VIEWED BY EXCURSIONISTS**

6 POINT No 6

30 A \$1 25

**INDEPENDENT CITIZENS  
FAVORABLE TO RAPID TRANSIT**

6 POINT No 5

32 A \$1 25

**NAVIGATION SUSPENDED  
BETWEEN TWILIGHT AND MIDNIGHT  
1234567890**

6 POINT No 4

34 A \$1 25

**CIRCUMSTANTIAL EVIDENCE  
PRODUCED BY THE DISTRICT ATTORNEY  
1234567890**

AMERICAN TYPE FOUNDERS COMPANY



**Combination Italic Gothic**

46 POINT NO 150

4 A \$4 00

***DEALER WEIGH***

36 POINT NO 149

6 A \$3 40

***PLEASING CONCERTS***

24 POINT NO 136

6 A \$2 50

***DISTRICT BOARD ELECTED***

24 POINT NO 137

10 A \$2 25

***HANDLING STOLEN OVERSHOES***

18 POINT NO 136

14 A \$2 00

***KNOWLEDGE  
CROUPERS BROKEN***

12 POINT NO 134

20 A \$1 40

***HANDSOME STRUCTURE  
BEAUTIFUL MASONIC TEMPLES***

6 POINT NO 132

30 A \$1 35

***CONGRESSIONAL QUESTIONS  
REPRESENTING NORTHERN MEMBERSHIP  
1 2 3 4 5 6 7 8 9 0***

12 POINT NO 135

16 A \$1 40

***STRONG ATHLETES  
ASSOCIATIONS JUBILANT***

12 POINT NO 133

24 A \$1 40

***FOREIGNERS IMPORTING  
AMERICAN STEAMSHIPS CONTESTED***

6 POINT NO 131

40 A \$1 35

***DELIGHTFUL DECEMBER SKATING  
BANQUET OF THE CANADIAN SNOWSHOE ASSOCIATION  
1 2 3 4 5 6 7 8 9 0***

AMERICAN TYPE FOUNDERS COMPANY

30 POINT No 112

10A 14 a \$4 50

**BUFFALO HUNTERS**  
*Relating Their Wild Adventure*

20 POINT No 112

18A 24 a \$3 65

**CHRISTMAS ENJOYMENT**  
*Big Turkey Gobbler Stuffed with Oysters*

18 POINT No 112

18A 25 a \$2 80

**NOCTURNAL MUSICAL DIVERSION**  
*Given by the Neighboring Cats, Free to All Who Listen*

12 POINT No 112

22A 38 a \$2 50

**MADAME TATTLER'S BOARDING SCHOOL**  
*For Young Ladies Who Delight in Talking Much and Saying Little*

10 POINT No 112

30A 42 a \$2 80

**MARVELOUS MARKSMEN**  
*Shooting at the Face in the Moon*

8 POINT No 112

36A 52 a \$2 80

**PRACTICE MAKES PERFECT**  
*Skill Acquired Only by Constant Practice*

8 POINT No 113

30A 52 a \$2 00

**REQUIRE NO VINDICATION**  
*Good Morals and an Honest Upright Life*

8 POINT No 113

30A 80 a \$2 40

**PICTURESQUE DRIVEWAYS**  
*Scenery Along the Roads near Fort Thomas*

6 POINT No 112

30A 80 a \$2 00

**DAILY SPARRING EXHIBITIONS**  
*Given by Rowdies Hard Fist and Tough Knuckle*

5 POINT ON 6 POINT No 112

30A 80 a \$2 00

**GLORIOUS AND BLESSED SPRING**  
*When Fields Turn Green and the Robins Warble and Sing*

1 2 3 4 5 6 7 8 9 0

1 2 3 4 5 6 7 8 9 0

Doric Italic Series

60 POINT

4 A 5 a \$15 50

***The END***

48 POINT

4 A 5 a \$10 75

***DOG Carts***

36 POINT

5 A 7 a \$8 75

***Crowd LARGE***

30 POINT

5 A 7 a \$6 50

***SPECIAL Markets***

24 POINT

6 A 10 a \$5 00

***Cheap VEST***

18 POINT

8 A 12 a \$4 50

***Money FOUND***

12 POINT

10 A 20 a \$4 25

***RECOGNITION***  
***Entertain Nobleman***

10 POINT

12 A 25 a \$4 00

***HOSTILE TRIBES***  
***Prepare Twenty Braves***

6 POINT

15 A 30 a \$3 75

***LECTURING COURSES***  
***Members Securing Tickets***

6 POINT

18 A 40 a \$3 50

***AMBITIOUS AUSTRALIAN***  
***Promises Many Business Chances***

**1 2 3 4 5 6 7 8 9 0**

**1 2 3 4 5 6 7 8 9 0**

AMERICAN TYPE FOUNDERS COMPANY

72 POINT

4 A 6 a \$9 00

Lighthouse SOLITUDE

60 POINT

6 A 9 a \$8 70

SEASHORE Promenaders

48 POINT

6 A 10 a \$7 00

Roadbeds for Baby CARRIAGES

40 POINT

6 A 12 a \$5 75

INDEPENDENTS for Ringmuzzled Suffrage

36 POINT

10 A 14 a \$4 90

Dark Lantern RANGERS

24 POINT

14 A 20 a \$4 50

Bright Geographical INTELLECT

18 POINT

16 A 25 a \$3 20

SODOM AND GOMORRAH  
Unpleasant Foresmellings of Devildom  
1234567890

12 POINT

20 A 30 a \$2 50

ADDEPATED COMMUNISTS  
Pandemaniacs on Lightning Locomotives  
1234567890

**French Clarendon No 40**

48 POINT

7 A 10 a \$11 80

**SCENIC Comedies**

36 POINT

10 A 14 a \$8 85

**Coliseum CONTESTS**

28 POINT

14 A 20 a \$7 50

**DEXTEROUS Grandchildren**

24 POINT

18 A 20 a \$5 25

**Superb Uppertendom EXQUISITES**

18 POINT

22 A 28 a \$4 25

**EVENTIDE BALSAM from Mountain and Prairie**

12 POINT

25 A 42 a \$4 15

**MAGIC CIRCLES**  
**Gold Engagement Rings**

10 POINT

38 A 52 a \$3 25

**ATHLETIC PASTIMES**  
**Football and Lacrosse at Belmont**

8 POINT

38 A 70 a \$2 85

**PHILANTHROPIC ACADEMY**  
**Professors Poundfoolish and Pennypacker**  
**1234567890**

6 POINT

52 A 70 a \$2 50

**WONDERFUL STONE MUMMIES**  
**Earthenware Cooking Utensils and Handsome Engraving**  
**1234567890**

**AMERICAN TYPE FOUNDERS COMPANY**

**French Clarendon Extended No 40**

28 POINT

5 A 8 a \$6 20

**CORRECT**  
**Spring Bonnet**

22 POINT

7 A 10 a \$5 20

**RIPENING**  
**Luscious Oranges**

18 POINT

12 A 14 a \$5 10

**PROPOSITION**  
**Extradited Defaulters**

12 POINT

16 A 20 a \$4 70

**TRUE ECONOMY**  
**Retrenching Extravagance**

11 POINT

18 A 28 a \$4 55

**MEAN BANKING**  
**Extorting and Dividing Funds**

10 POINT

22 A 32 a \$4 05

**HEEDLESS**  
**Stock Speculation**

8 POINT

25 A 38 a \$3 75

**SAND MOUNT**  
**Expense of Barrenness**

8 POINT

30 A 42 a \$3 15

**FUTURITY FARM**  
**Seeds of Gratitude and Love**  
1 2 3 4 5 6 7 8 9 0

5 POINT

30 A 42 a \$3 35

**SURE ROAD TO DEATH**  
**Late Hours and Daily Worrying**  
1 2 3 4 5 6 7 8 9 0

**AMERICAN TYPE FOUNDERS COMPANY**

## Broadgauge Series

40 POINT

5 A \$10 70

# HOMIES

38 POINT

5 A \$8 85

# SON

28 POINT

5 A \$8 10

# RUM

22 POINT

7 A \$4 65

# FINES

18 POINT

10 A \$5 05

# DOINGS

12 POINT

14 A \$4 20

# CONCRETE

10 POINT

18 A \$4 05

# ORNAMENTS

8 POINT

22 A \$3 80

# STEAM HORSES

12345678

8 POINT

25 A \$3 40

# MIDNIGHT MUSINGS

1234567890

## Hardware Series

38 POINT

3 A \$5 50

# FINED

24 POINT

6 A \$4 15

# SUN

18 POINT

6 A \$2 45

# HOSE

12 POINT

10 A \$2 10

# BRIGHT

12345

10 POINT

10 A \$1 55

# RANGERS

123456

AMERICAN TYPE FOUNDERS COMPANY

Latin Extended Series

36 POINT

3A 4a \$6 65

**NO Hop**

30 POINT

4A 6a \$6 90

**Sing OUT**

24 POINT

6A 6a \$6 95

**RIDES  
Short Haul**

16 POINT

6A 12a \$5 60

**HONESTY  
Better Policy**

14 POINT

10A 14a \$4 95

**SOLDIERY  
Furiously Battled**

12 POINT

12A 20a \$3 40

**REAPING  
Golden Grain**

10 POINT

16A 24a \$3 60

**HAZARDOUS  
Mountain Roads**

6 POINT

24A 32a \$3 75

**AMERICAN  
Original Inhabitant  
12345678**

6 POINT

30A 40a \$3 90

**PERISHABLE  
Freight Safely Landed  
1234567890**

AMERICAN TYPE FOUNDERS COMPANY



Keystone Series

40 POINT

5 A 7 a \$8 85

**DEPOSITS**  
**Grand Church**

38 POINT

7 A 10 a \$8 85

**CHESTNUTS**  
**Famous Reports**

28 POINT

8 A 14 a \$7 95

**FAST**  
**Roadster**

22 POINT

10 A 14 a \$5 30

**GREAT**  
**Institutions**

18 POINT

14 A 14 a \$4 35

**BROKEN**  
**Window Grate**  
**123456**

12 POINT

18 A 28 a \$3 55

**DETECTIVES**  
**Fashionable Women**  
**12345678**

Modern Antique Wide No 110

48 POINT

3 A 4 a \$8 90

**LIST price**

AMERICAN TYPE FOUNDERS COMPANY

72 POINT

3 A 4 a \$11 20

New GUM

60 POINT

4 A 5 a \$10 25

EAST Ends

48 POINT

5 A 8 a \$10 90

Bright STARS

42 POINT

6 A 10 a \$8 90

EMBLEMS  
Proudly Floating

36 POINT

8 A 12 a \$8 50

SCIENTIFIC  
Electrical Appliance

**Modern Antique**

30 POINT

10 A 16 a \$6 40

**PUBLIC SCHOOL  
Engineering Department**

20 POINT

12 A 20 a \$4 50

**WEDDING COSTUMES  
Beautiful Parisian Importations**

16 POINT

16 A 24 a \$3 90

**OBSERVE THE GOLDEN RULE  
Paving the Pathway to Eternal Happiness**

12 POINT

20 A 40 a \$3 00

**THE UNITED STATES BANK NOTES  
Reliable as Coin and Much More Convenient to Carry**

10 POINT

24 A 50 a \$3 00

**A HAT IS THE DOME, THE STEEPLE TOP  
Where Stray Thoughts are Caught, and are Caged by Memory**

6 POINT

30 A 60 a \$3 00

**THE ROLLING SEASONS PASS RAPIDLY AWAY  
Noble Deeds never Die, but Live Forever and Bloom in Lasting Spring  
1 2 3 4 5 6 7 8 9 0**

6 POINT

30 A 60 a \$2 50

**HARD IS HIS FATE ON WHOM THE PUBLIC GAZE IS FIXED  
To Detract or Sparingly Praise ; Repose Denies her Requiem to his Honorable Name  
1 2 3 4 5 6 7 8 9 0**

**AMERICAN TYPE FOUNDERS COMPANY**

**Baskerville Series**

72 POINT

4 A 6 a \$6 55

**MUSIC Professors**

60 POINT

4 A 7 a \$6 25

**Unfriendly KNIGHTS**

48 POINT

5 A 8 a \$5 25

**SCIENTIFIC Preparations**

36 POINT

6 A 10 a \$4 20

**Court HOUSES**

30 POINT

6 A 12 a \$3 70

**Merino DRESSES**

24 POINT

12 A 16 a \$3 45

**YOUNG HEROES  
Undaunted Defenders**

18 POINT

20 A 30 a \$3 25

**REAL BARGAINS  
Building Lots in Swampoodle**

12 POINT

25 A 36 a \$2 35

**HEALTHFUL EXERCISE  
Garden Cultivation Before Breakfast  
1 2 3 4 5 6 7 8 9 0**

9 POINT

30 A 45 a \$2 15

**BENIGHTED TRAVELERS  
Discomforts of Sojourning in Amsterdam  
1 2 3 4 5 6 7 8 9 0**

## Latin Compressed No 30

48 POINT

8 A 10a \$6 55

# BRIGHT Government Schools

40 POINT

8 A 12a \$5 75

# Princeton and Columbia CONTESTS

36 POINT

8 A 12a \$4 45

## HUMBLE MEN

### Beaten Politicians

24 POINT

10 A 15a \$3 75

## INVESTIGATIONS

### Political Examination

18 POINT

15 A 20a \$3 20

## ENGINE COMPANIES

### Approved Road Management

1234567890

12 POINT

20 A 30a \$2 15

## MODERN ARTISTIC CARICATURES

### Graphic and Brilliant Portrayal of Life

1234567890

---

## Egyptian No 25

10 POINT

20 A 30a \$2 75

## PROFANE SPEECH ABOLISHED

### Trying Modern Automatic Devices for Progressive Compositors

8 POINT

24 A 36a \$2 50

## DIVINITY THAT SHAPES OUR ENDS

### The Trees are Clothed with Leaves, the Fields with Grass and Blossoms

1234567890

---

AMERICAN TYPE FOUNDERS COMPANY

Old Style Antique No 42

48 POINT

3 A \$5 00

MUSINGS

40 POINT

5 A \$4 80

INQUIRER

36 POINT

7 A \$4 50

FRENCHMEN

24 POINT

10 A \$3 75

MAIDEN SMILES

22 POINT

12 A \$3 15

CHARMING POETRY

18 POINT

14 A \$2 45

FEARLESS YOUNG ROMAN

12 POINT

18 A \$1 80

DELICIOUS CANVAS-BACK DUCKS  
1234567890

AMERICAN TYPE FOUNDERS COMPANY

Latin Antique No 40

48 POINT

3 A 4 a \$7 45

China DISH

36 POINT

5 A 8 a \$8 05

MILK Crackers

30 POINT

6 A 8 a \$4 95

Household WORDS

24 POINT

8 A 14 a \$4 70

DAIRYMAIDS  
Regular Business Gowns

18 POINT

12 A 18 a \$3 80

COMING TOURIST  
Jaunting Beyond the Mountains

12 POINT

14 A 28 a \$2 95

BURDENSOME  
Weighing Machines

10 POINT

20 A 32 a \$2 95

HAYSEEDERS  
Untutored Dunderpates

8 POINT

22 A 42 a \$2 95

WINTER STORMS  
Sweeping Hurricane Decks  
1234567890

8 POINT

25 A 52 a \$2 90

IMPECUNIOSITY  
Decidedly Small Bank Accounts  
1234567890

AMERICAN TYPE FOUNDERS COMPANY

Lightface Celtic

48 POINT No 150

3 A 4 a \$8 50

THE Pink

38 POINT No 150

4 A 6 a \$6 25

Beaver NETS

30 POINT No 150

5 A 7 a \$5 00

LEND S Gamester

22 POINT No 40

10 A 14 a \$4 95

ENTERPRISE  
Making Ocean Breezes

18 POINT No 40

14 A 20 a \$4 55

RECONSTRUCTION  
Fuglemen Swearing Allegiance

12 POINT No 40

25 A 32 a \$4 30

AGONIZING  
Felines Nightly Song

10 POINT No 40

25 A 42 a \$3 70

INDIFFERENCE  
Unconcerned Spectators

8 POINT No 40

36 A 52 a \$4 20

MODERN KNIGHTS  
Heart of Tender Sensibility  
1234567890

6 POINT No 40

36 A 70 a \$3 70

EUREKA RESTAURANT  
Gutta Percha Beef and Ram Chops  
1234567890

AMERICAN TYPE FOUNDERS COMPANY



French Old Style Extended

72 POINT

3 A 5 a \$12 50

Rescuer

60 POINT

4 A 5 a \$11 75

Foremost

48 POINT

4 A 5 a \$7 50

Enumerate

36 POINT

4 A 8 a \$5 25

BONE Breakers

30 POINT

5 A 10 a \$4 75

Heroine NUMBER

24 POINT

6 A 12 a \$4 00

HERO  
Denounced

18 POINT

6 A 16 a \$3 00

RECORD  
Easily Broken

12 POINT

15 A 30 a \$2 75

358 MINERS  
Seriously Consider

10 POINT

16 A 36 a \$2 75

NUMBER 246  
Desires Wardens Pardon

AMERICAN TYPE FOUNDERS COMPANY

## Celtic No 42

28 POINT

8 A \$3 80

PURSE

18 POINT

14 A \$2 85

RUMBLING

10 POINT

30 A \$2 35

FORCING NATURE

7 POINT

36 A \$2 15

GINSLING THE WRESTLER  
1234567890

24 POINT

10 A \$3 70

NIMROD

12 POINT

22 A \$2 50

BRIGHT MORN

8 POINT

30 A \$2 05

SHIRKING LABORERS

6 POINT

36 A \$1 45

EXPOUNDERS OF MODERN SYSTEMS  
1234567890

## Norman Condensed

36 POINT

5 A 6 A \$4 50

SEASIDE PROMENADE

5 A 8 A \$3 83

SAVE MEXICAN HUNTERS

18 POINT

10 A 16 A \$3 15

WIRED MIDNIGHT PHANTOMS  
DARK APPREHENSIBLE GHOSTLY APPARITION

12 POINT

20 A 32 A \$2 95

OFFICIAL BUSINESS  
MUNICIPAL INDEBTEDNESS  
1234567890

10 POINT

20 A 32 A \$2 93

CHRISTMAS THOUGHTS  
FAIR WONDERLAND PANORAMA  
1234567890

AMERICAN TYPE FOUNDERS COMPANY

Lightface Runic No 30

80 POINT

3 A 5 a \$9 45

BANK Order

48 POINT

4 A 6 a \$8 55

Seashore RACES

40 POINT

5 A 8 a \$7 25

PROGRESSIVE  
Modern Rural School

28 POINT

6 A 10 a \$6 15

LIBERAL  
Coal Dealers

22 POINT

10 A 15 a \$5 85

PLEASANT  
Summer Sport

18 POINT

12 A 20 a \$5 35

EXCEPTIONAL  
Athletic Exercises

14 POINT

15 A 25 a \$4 75

MODERN DESIGNS  
Artistic Color Printing

12 POINT

15 A 25 a \$3 45

INDUSTRIAL BUSINESS  
Rare Tools and Implements  
1234567890

10 POINT

20 A 30 a \$3 00

TERRESTRIAL PHENOMENA  
Doubtful Calculations of Geologists  
1234567890

AMERICAN TYPE FOUNDERS COMPANY

80 POINT

4 A 6 a \$9 00

# BRISK Dames

46 POINT

4 A 7 a \$6 50

# Rare MUSIC Box

36 POINT

6 A 8 a \$5 00

# Aspirants EXAMINED

30 POINT

7 A 10 a \$4 25

# Quaint HAMBURG Stones

24 POINT

10 A 15 a \$3 75

# URCHINS Grand Display

18 POINT

12 A 18 a \$3 25

# ANTIQUATED Miniature Camera

12 POINT

22 A 35 a \$3 00

# PARISIAN HEADREST Beautiful Result Obtained

10 POINT

26 A 40 a \$2 75

# EVENING PROMENADES Invigorating and Rejuvenating

8 POINT

30 A 50 a \$2 50

# AMATEUR KODAK SOCIETY Picturesque Moonbeams Reproduced 1234567890

8 POINT

35 A 52 a \$2 25

# UNIVERSAL ART EXHIBITION Highly Complimented Marine Photography 1234567890

48 POINT

4A 5a \$7 75

**PLEASING  
Newest Master**

36 POINT

5A 6a \$5 50

**EXCURSIONS  
Returning Delegates  
Butter Cakes**

24 POINT

10A 15a \$4 50

**DARKEST  
African Mines  
Studying**

18 POINT

12A 20a \$4 00

**INDUSTRIAL  
Workers Gathered  
Destructions**

12 POINT

16A 25a \$3 25

**YOUNG HEROES  
Purchase Made Christmas  
1 2 3 4 5 6 7**

10 POINT

20A 30a \$3 00

**PRINTING MATERIAL  
Handsome Durable and Extensive  
1 2 3 4 5 6 7 8 9 0**

**Quentell Series**

72 POINT

4A 5a \$17 00

**MENS Club**

60 POINT

4A 5a \$12 25

**Count GIRLS**

54 POINT

4A 5a \$10 25

**QUICK Return**

46 POINT

4A 5a \$7 75

**Order GENERAL**

42 POINT

4A 6a \$7 25

**EXCURSIONS  
Divorce Register**

AMERICAN TYPE FOUNDERS COMPANY

**Quentell Series**

36 POINT

5 A 8 a \$5 50

**PERFORMANCES**  
**Remarkable Country**

30 POINT

6 A 9 a \$5 00

**CORRESPONDENCE**  
**Distinguished Questions**

24 POINT

6 A 10 a \$4 00

**ENTERPRISING MERCHANT**  
**Sending Phonograph Message**

16 POINT

10 A 16 a \$3 25

**UNREALIZATION**  
**Beautiful Floriated**

12 POINT

16 A 20 a \$3 00

**POCKET ESTIMATE**  
**Provocation and Sensation**

6 POINT

22 A 30 a \$2 50

**THROUGH COUNTLESS DANGERS**  
**Charitable Society Distributing Clothing**  
**1 2 3 4 5 6 7 8 9 0**

14 POINT

12 A 16 a \$3 25

**BASEBALL GAMES**  
**Enchanted Amusement**

10 POINT

20 A 26 a \$2 75

**PHOTOGRAPHERS RESOLUTION**  
**Beautiful, Glorious and Charming**

6 POINT

24 A 36 a \$2 25

**PATENT CYLINDER PRINTING MACHINE**  
**Magnificent Assortment Woodwork Exhibited**  
**1 2 3 4 5 6 7 8 9 0**

**AMERICAN TYPE FOUNDERS COMPANY**

De Vinne Series

72 POINT

4A 5a \$17 00

Iron RIM

60 POINT

4A 5a \$12 25

TIN Block

54 POINT

4A 5a \$10 25

Silver ORE

46 POINT

4A 5a \$7 75

GUM Covers

42 POINT

4A 6a \$7 25

Comical SONG

36 POINT

5A 8a \$5 50

SPRING Bonnets

*For De Vinne Poster Fonts, see pages 330 and 331. For De Vinne Fractions, see pages 330 and 331*

AMERICAN TYPE FOUNDERS COMPANY



De Vinne Series

30 POINT

6 A 9 a \$5 00

Harvesters REAPING

24 POINT

8 A 10 a \$4 00

MASSACHUSETTS  
Philanthropic Associations

16 POINT

10 A 16 a \$3 25

WILDCAT INVESTMENT  
Unsuccessful Business Transaction

14 POINT

12 A 18 a \$3 25

INTERNATIONAL HOSPITALITY  
Receptions and Suppers to Foreign Visitors

12 POINT

16 A 20 a \$3 00

SHARPSHOOTER  
Professional Marksman

10 POINT

20 A 26 a \$2 75

DEVELOP MUSCLES  
Healthful Gymnastic Exercise

6 POINT

22 A 30 a \$2 50

ROMANTIC SCENERY  
Beautiful Mountainous Landscapes

7 POINT

22 A 34 a \$2 50

BRAVE SAILORS SAVED  
Sunshine Brings Happiness to Mariners

6 POINT

24 A 36 a \$2 25

HONORABLE COMPETITION  
Amateur Athletes Receive Encouragement

5½ POINT

24 A 36 a \$2 50

BARGAINS IN MACKINTOSHES  
People Who are Always Without Umbrellas

1 2 3 4 5 6 7 8 9 0

1 2 3 4 5 6 7 8 9 0

*For De Vinne Poster Fonts, see pages 330 and 331. For De Vinne Fractions, see pages 330 and 331*

AMERICAN TYPE FOUNDERS COMPANY

72 POINT

4 A 5 a \$15 00

RICH Print

60 POINT

4 A 5 a \$10 00

Sharp SHOD

54 POINT

4 A 5 a \$7 50

WORD Marks

48 POINT

4 A 5 a \$6 00

Greater GAMES

42 POINT

4 A 6 a \$5 50

DOUBLE Machine

36 POINT

5 A 8 a \$5 00

Moustache GROWING

*For De Vinne Condensed Poster Fonts see pages 332 and 333*

AMERICAN TYPE FOUNDERS COMPANY

30 POINT

6 A 9 a \$4 50

**CRIMSON CLOUDS**  
**Moving Swiftly Northward**

24 POINT

8 A 12 a \$4 00

**BENJAMIN FRANKLIN**  
**Greatest Energetic Achievements**

18 POINT

10 A 16 a \$3 25

**FERTILE GARDEN DRENCHED**  
**Rainmakers Incessantly Supplied Moisture**

14 POINT

12 A 20 a \$3 25

**MERCHANTS NATIONAL FRATERNITY**  
**Grand Complimentary Summer Railroad Excursions**

12 POINT

18 A 22 a \$3 00

**SHOCKING MODESTY**  
**Enormous Masculine Bloomers**

10 POINT

22 A 30 a \$2 75

**EXHIBITING ARCHITECTURE**  
**Cotton States International Exposition**

8 POINT

25 A 38 a \$2 50

**MATHEMATICAL CALCULATION**  
**Foretells Severe Atmospheric Disturbances**  
**1 2 3 4 5 6 7 8 9 0**

8 POINT

30 A 42 a \$2 25

**BRIGHT MORNING SUNLIGHT SHINES**  
**Contemplating Miscellaneous Telescopic Observations**  
**1 2 3 4 5 6 7 8 9 0**

*For De Vinne Condensed Poster Fonts see pages 332 and 333*

**AMERICAN TYPE FOUNDERS COMPANY**

72 POINT

4 A 5 a \$15 00

NOBLE Horses

80 POINT

4 A 5 a \$9 00

Brought ROCKER

54 POINT

5 A 7 a \$8 00

DURABLE Flooring

48 POINT

5 A 8 a \$7 00

Landscape IMPROVED

42 POINT

6 A 10 a \$6 00

MODERN CUISINE  
Clothed in Deep Mystery

36 POINT

6 A 12 a \$5 50

**COLLEGE MONTHS**  
**Bright Maidens in Attendance**

30 POINT

8 A 12 a \$5 00

**NUMEROUS LANDMARKS**  
**Throughout Cumberland Discovered**

24 POINT

10 A 18 a \$4 00

**INNUMERABLE REQUISITIONS**  
**Administration Upholding Monroe Doctrines**

18 POINT

12 A 20 a \$3 25

**DISPLAY BEAUTIFUL FLORAL DESIGNS**  
**Seventh Annual International Chrysanthemum Exhibit**

14 POINT

18 A 22 a \$3 25

**NATIONAL CONVENTION**  
**Mississippi Valley Metropolis**  
**1 2 3 4 5 6 7 8 9 0**

12 POINT

20 A 26 a \$3 00

**VENEZUELAN COMMISSION**  
**Arbitration Now Becomes Necessary**  
**1 2 3 4 5 6 7 8 9 0**

De Vinne Extended

---

48 POINT

3 A 4 a \$11 50

HOME  
Fashions

42 POINT

4 A 5 a \$10 00

FARMS  
Fine Cattle

36 POINT

4 A 6 a \$8 00

SPRING  
Sugar Barrel

30 POINT

5 A 6 a \$7 00

INDUSTRY  
Missouri Firms

**De Vinne Extended**

24 POINT

6A 10a \$8 00

**EXPOSITION**  
**Home Manufacture**

18 POINT

9A 12a \$4 50

**UNIFORM PRINT**  
**Looks Plain and Artistic**

14 POINT

10A 14a \$3 75

**BEAUTIFUL SCENE**  
**Views From Excursion Boats**

12 POINT

14A 18a \$3 50

**NINETEENTH CENTURY**  
**Base Ball and Lawn Tennis Player**

10 POINT

18A 24a \$3 00

**EUROPEAN BICYCLE EXHIBITION**  
**American Products Receive Highest Awards**  
**Enterprising Competitors**

8 POINT

22A 30a \$2 75

**MODEST YOUTHS**  
**Introduced to Director**  
**Gratifying Result**  
**12345678**

6 POINT

24A 36a \$2 50

**JUVENILE ORCHESTRA**  
**Renders Popular Selections**  
**Thursday Evening**  
**1234567890**

**AMERICAN TYPE FOUNDERS COMPANY**

72 POINT

4A 5a \$19 00

*Lost RIG*

60 POINT

4A 5a \$13 25

*RUN Fast*

54 POINT

4A 5a \$11 25

*Read NICE*

48 POINT

4A 5a \$7 75

*BEAR Skins*

42 POINT

4A 8a \$7 25

*Beaver DIVES*

36 POINT

5A 8a \$6 50

*GRAND Festival*



30 POINT

8 A 9 a \$5 75

***BLUSTERING  
Destructive Cyclones***

24 POINT

8 A 10 a \$4 50

***FIRING ROCKETS  
Distress Signals Answered***

18 POINT

10 A 16 a \$4 00

***WANDERING ARABIANS  
Experienced Numerous Hardships***

14 POINT

12 A 16 a \$3 25

***DELIGHTFUL HOLIDAY SEASON  
Society Whirlwinds Unceasingly Blowing***

12 POINT

16 A 20 a \$3 00

***UNDERSTANDS  
Thoroughly Mechanical***

10 POINT

20 A 26 a \$2 75

***ARMENIAN MASSACRE  
Turkish Cruelty Shows Plainly***

8 POINT

22 A 30 a \$2 50

***CHICAGO WEEKLY NEWS  
Universally Pronounced Brilliancy  
1234567890***

6 POINT

24 A 36 a \$2 25

***AMERICAN TYPE FOUNDERS  
Manufactures Superior Printing Materials  
1234567890***

72 POINT

4A 5a \$17 00

*Red* *INK*

60 POINT

4A 5a \$12 25

*HER* *Pets*

54 POINT

4A 5a \$10 25

*Little* *BOY*

48 POINT

4A 5a \$7 75

*DREAMS*  
*Interpretator*

42 POINT

4A 6a \$7 25

*RELIABLE*  
*Hardy Planter*

*This Series will register for color printing with De Vinne Italic on pages 106 and 107*

36 POINT

5 A 6 a \$6 50

*SPECIMEN  
Printers Journal*

30 POINT

6 A 9 a \$5 75

*DEMONSTRATE  
Handsome Furnisher  
Conclusively*

24 POINT

8 A 10 a \$4 50

*SCARED  
Farm Maids*

16 POINT

10 A 16 a \$4 00

*RELIABLE  
Italic Type Made*

14 POINT

12 A 16 a \$3 25

*AGRICULTURE  
Employing Farmer  
13579*

12 POINT

16 A 20 a \$3 00

*CONTRIBUTOR  
Receives Remuneration  
1234567*

*This Series will register for color printing with De Vinne Italic on pages 196 and 197*

60 POINT

3 A 4 a \$12 35 4 a \$4 55

NO Card

36 POINT WITH 60 POINT INITIALS

RICH Funds

48 POINT

3 A 5 a \$9 35 5 a \$3 75

Same CAR

24 POINT WITH 48 POINT INITIALS

Winsome LADIES

36 POINT

5 A 6 a \$8 00 6 a \$3 65

GAME Record

AMERICAN TYPE FOUNDERS COMPANY

24 POINT

10A 15a \$7 05 15a \$3 15

# MORE Homes

16 POINT WITH 36 POINT INITIALS

## Quaint SCENE

16 POINT

15A 20a \$6 10 20a \$2 65

## ANIMATED Fervent Comedian

15 POINT

16A 25a \$5 00

## WINTER GAMES Stormy Weather Endured

12 POINT

25A 35a \$4 25

## HANDSOME STEAMER Expedition Traveling Homeward

10 POINT

26A 40a \$3 75

## ELECTRIC LIGHTING Resplendent Spectacular Extravaganza

6 POINT

30A 45a \$3 50

## SPARKLING OPERATIC COMEDY Burlesque Company Received Great Applause

6 POINT

35A 50a \$3 25

## FALLTIME CLOTHING SACRIFICED Bargain Sale Advertised for Every Tuesday in March

1234567890

Columbus Initials

36 POINT \$2 00

46 " 3 00

60 " 4 00

B  
C  
E  
F  
K  
L  
O  
Q  
R  
S  
T  
V  
W

POINTS CONTAIN THE ABOVE CAPITALS ONLY

60 POINT

3 A 4 a \$12 35

Rendered  
SONG

36 POINT WITH 60 POINT INITIALS

RICH Funds

46 POINT

3 A 5 a \$9 35

CHARM  
Fascination

*This Series will register for color printing with Columbus No. 2 on pages 200 and 201*

AMERICAN TYPE FOUNDERS COMPANY

36 POINT

5 A 8 a \$8 00

36 POINT \$2 00  
48 " 3 00  
80 " 4 00

Recreation  
GAME

24 POINT WITH 48 POINT INITIALS

COLD Winds

24 POINT

10A 15a \$7 05

VISITOR  
Modest Homes

18 POINT WITH 36 POINT INITIALS

Quaint SCENE

18 POINT

15 A 20 a \$8 10

ANIMATED  
Fervent Comedian  
1 2 3 4 5 6

*This Series will register for color printing with Columbus No. 4  
on pages 200 and 201*

B  
C  
E  
F  
K  
L  
Q  
R  
S  
T  
V  
W

FFONTS CONTAIN THE ABOVE  
CAPITALS ONLY

4 A 5 a \$9 00

60 POINT

4 A 5 a \$9 50

HOMES 5 Great

4 A 6 a \$6 00

54 POINT

4 A 6 a \$6 50

BROKEN HEARTS

Pointed 38 Reason

5 A 6 a \$7 00

48 POINT

5 A 6 a \$7 50

YOUR BOSTON BOYS

America £17 Forever

6 A 10 a \$6 00

42 POINT

6 A 10 a \$6 50

PERIODICAL MOVEMENT

3 Modern Ideas Tremble 5

*This Series will register for color printing*

AMERICAN TYPE FOUNDERS COMPANY



6 A 12 a \$5 00

30 POINT

6 A 12 a \$5 50

# RICHEST BANKER EXPIRES Complicated 827 Machinery

10 A 16 a \$4 00

24 POINT

10 A 16 a \$4 50

# STRANGE INHERITANCE QUESTION 89 Curious Treatment Foretold 78

12 A 20 a \$3 25

18 POINT

12 A 20 a \$3 50

# INTEREST COUNTED 123456 DURING VACATIONS Regular Investments Thoroughly Published

12 POINT

20 A 30 a \$3 00

## WOEFUL WITCH THEORY Early Puritan Doctrines 49

12 POINT

20 A 30 a \$3 00

## WOEFUL WITCH THEORY Early Puritan Doctrines 48

10 POINT

24 A 36 a \$2 75

## DELUDED RELIGIOUS CHRONIC Drives People to Distraction \$260

10 POINT

24 A 36 a \$2 75

## DELUDED RELIGIOUS CHRONIC Drives People to Distraction \$260

8 POINT

28 A 40 a \$2 50

## POPULAR PASTIMES THROWN OVER Modern Society Shocked Festive Board and 94 Ball Discouraged

6 POINT

30 A 50 a \$2 25

## HISTORY REVEALS HARD PUNISHMENT Oaken Stocks and Cowhide Lashes Terrible Deeds Rectified by Christianity 48

*This Series will register for color printing*

AMERICAN TYPE FOUNDERS COMPANY

De Vinne Shaded

72 POINT

4 A 5 a \$17 00

HIS Dish

60 POINT

4 A 5 a \$12 50

Dead MET

54 POINT

4 A 5 a \$10 50

BIRD Catch

48 POINT

4 A 5 a \$7 75

Steak RANK

42 POINT

4 A 6 a \$7 50

TRIED Articles

36 POINT

5 A 6 a \$5 75

Lad HIT

24 POINT

8 A 10 a \$4 50

HARD Earth

18 POINT

10 A 16 a \$3 75

ACTOR Pleasing

12 POINT

16 A 20 a \$3 25

Triumphant CHARMER

1 2 3 4 5 6 7 8

1 2 3 4 5 6 7 8 9 0

Epitaph and Epitaph Open

3 A \$6 00

48 POINT

3 A \$6 00

**MACHINERY**

5 A \$4 25

36 POINT

5 A \$4 25

**LADS LEND BIKE**

7 A \$3 25

24 POINT

7 A \$3 25

**NORTHSHORE  
HUNTS LEGAL NOTICE**

16 POINT

9 A \$2 50

**EXCHANGING PRODUCE  
JOINT DEBATE <sup>AND</sup> FALSE TALKS**

12 POINT

14 A \$2 25

**PERIODICAL CIRCULATIONS  
WHISTLING HURRICANES TURNING PYRAMIDS  
1234567890**

*The 24, 36 and 48 Point sizes of this Series will register for color printing*

AMERICAN TYPE FOUNDERS COMPANY

48 POINT

4 A \$4 00

GRAND · JOKER

36 POINT

6 A \$3 40

EVENING · SERMON

24 POINT

8 A \$2 90

THIRD · NATIONAL · BANK

18 POINT

10 A \$2 25

STRONG · AND · HEARTY  
HISTORIC · CHESTNUT · SOCIETY

12 POINT

14 A \$1 90

REVIEWING GRAND PARADE  
PHILADELPHIA · VETERAN · ASSOCIATION

10 POINT

20 A \$1 80

GOLD · AND · SILVER  
RICH DIAMOND FIELDS  
· 12345678 ·

8 POINT

24 A \$1 90

HUMPT · & · DUMPT  
DEALERS AND FURNISHERS  
· 1234567890 ·

# Quaint Open

PATENTED

48 POINT

4 A \$4 00

GRAND · JOKER

36 POINT

8 A \$3 40

EVENING · SERMON

24 POINT

8 A \$2 90

THIRD · NATIONAL · BANK

18 POINT

10 A \$2 25

STRONG · AND · HEARTY  
HISTORIC · CHESTNUT · SOCIETY

12 POINT

14 A \$1 90

REVIEWING GRAND PARADE  
PHILADELPHIA · VETERAN · ASSOCIATION

10 POINT

20 A \$1 90

GOLD · AND · SILVER  
RICH DIAMOND FIELDS  
· 1 2 3 4 5 6 7 8 ·

8 POINT

24 A \$1 90

HUMPT · & · DUMPT  
DEALERS AND FURNISHERS  
· 1 2 3 4 5 6 7 8 9 0 ·

*This Series will register for color printing with Quaint Series on opposite page*

AMERICAN TYPE FOUNDERS COMPANY

60 POINT

4 A 6 a \$7 50

OPENING Season

48 POINT

8 A 8 a \$8 50

Bountiful HARVESTS

36 POINT

6 A 10 a \$6 00

SLAUGHTERED Buffaloes

30 POINT

8 A 12 a \$5 50

Mexican VOLCANIC Eruptions

24 POINT

10 A 16 a \$4 00

BENEVOLENT GATHERINGS  
Honorable and Charitable Associations

18 POINT

12 A 20 a \$3 50

STRONG WIND  
Natural Flower Odors  
12345678

12 POINT

16 A 30 a \$3 00

PLEASING PRODUCTS  
Designed for Modern Printers  
1234567890

60 POINT

4A 6a \$7 50

OPENING Season

48 POINT

6A 8a \$6 50

Bountiful HARVESTS

36 POINT

6A 10a \$8 00

SLAUGHTERED Buffaloes

30 POINT

6A 12a \$5 50

Mexican VOLCANIC Eruptions

24 POINT

10A 16a \$4 00

BENEVOLENT GATHERINGS  
Honorable and Charitable Associations

18 POINT

12A 20a \$3 50

STRONG WIND  
Natural Flower Odors  
12345678

12 POINT

16A 30a \$3 00

PLEASING PRODUCTS  
Designed for Modern Printers  
1234567890

*This Series will register for color printing with Virile Series on opposite page*

48 POINT

4A 5a \$7 50

# SUPERB Style 4 Boats

42 POINT

4A 6a \$6 00

# Expert SONG 5

30 POINT

6A 8a \$5 50

# GRAND 2 Bargains

24 POINT

8A 12a \$4 00

# BARTON Historians 2

18 POINT

10A 18a \$3 50

# MEXICANS Grand 9 Sports

12 POINT

14A 24a \$3 00

# ACTORS FANCY Designed & Engraved

10 POINT

16A 32a \$2 75

# ELEGANT ROSES That Bloom in Spring 12

8 POINT

20A 32a \$2 50

# MONROE DOCTRINE Uncle Samuel Laying Plans 7

8 POINT

20A 40a \$2 25

# BOULEVARDS SPRINKLED German Band 29 Exquisite Melodies



48 POINT

4A 5a \$7 50

SUPERB  
Style 4 Boats

42 POINT

4A 8a \$8 00

Expert SONG 5

30 POINT

8A 8a \$5 50

GRAND 2 Bargains

24 POINT

8A 12a \$4 00

BARTON  
Historians 2

18 POINT

10A 18a \$3 50

MEXICANS  
Grand 9 Sports

12 POINT

14A 24a \$3 00

ACTORS FANCY  
Designed 8 Engraved

10 POINT

18A 32a \$2 75

ELEGANT ROSES  
That Bloom in Spring 12

8 POINT

20A 32a \$2 50

MONROE DOCTRINE  
Uncle Samuel Laying Plans 7

8 POINT

20A 40a \$2 25

BOULEVARDS SPRINKLED  
German Band 29 Exquisite Melodies

*This Series will register for color printing with Erratick Series on opposite page*

60 POINT

3 A 4 a \$8 25

*Denouncement*

48 POINT

3 A 8 a \$6 25

*Famous Workmen*

36 POINT

4 A 10 a \$5 25

*Determined Advertiser*

30 POINT

5 A 12 a \$4 75

*Reward Honest Merchants*

24 POINT

6 A 18 a \$4 25

*Scientific Explorations Postponed*

18 POINT

9 A 28 a \$3 75

*Enthusiastic Audience Became Ungovernable*

12 POINT

15 A 50 a \$3 25

*Dramatic Elocution Admired*

10 POINT

15 A 55 a \$3 00

*Patriotic Orators Arouse Natives*

8 POINT

15 A 55 a \$2 75

*Sensational News Eagerly Devoured*

8 POINT

15 A 60 a \$2 50

*Conservatives and Radicals Join Hands*

1 2 3 4 5 6 7 8 9 0

1 2 3 4 5 6 7 8 9 0

80 POINT

3 A 4 a \$6 25

*Denouncement*

48 POINT

3 A 6 a \$6 25

*Famous Workmen*

36 POINT

4 A 10 a \$5 25

*Remunerated  
Determined Advertiser*

30 POINT

5 A 12 a \$4 75

*Generous Patrons  
Reward Honest Merchants*

24 POINT

6 A 18 a \$4 25

*Meritorious Investigation  
Scientific Explorations Postponed  
1 2 3 4 5 6 7 8 9 0*

*This Series will register for color printing with Livermore Series on opposite page*

Contour No 1

48 POINT

4 A 8 a \$8 60

Black HORSE

36 POINT

5 A 10 a \$8 60

UNITED Service

26 POINT

8 A 12 a \$5 15

Carmine BRUSHES

24 POINT

6 A 16 a \$5 00

SURGICAL Operations

20 POINT

10 A 20 a \$5 00

CONSERVATORIES  
Musical Question Debated

16 POINT

10 A 20 a \$3 45

ENGAGED  
Choice Resort  
1 2 3 4 5 6

12 POINT

16 A 32 a \$3 25

CONSIDERED  
National Movement  
1 2 3 4 5 6 7

AMERICAN TYPE FOUNDERS COMPANY

Contour No 4

72 POINT

3A 5a \$11 95

Hire MEN

60 POINT

3A 5a \$9 45

END Games

48 POINT

4A 8a \$8 20

Defend RIGHT

40 POINT

4A 8a \$5 00

STORM Damaged

32 POINT

5A 10a \$4 90

Prominent FIREMEN

28 POINT

6A 12a \$4 00

REPORTER Promenading  
1234567890

AMERICAN TYPE FOUNDERS COMPANY

Contour No 6

72 POINT

3 A \$5 40

ENUMERATES

60 POINT

3 A \$3 75

BOND 45 MARK

48 POINT

4 A \$3 20

MODERN HEROES

40 POINT

5 A \$2 70

FAMOUS 68 GARDEN

32 POINT

8 A \$2 75

BEAUTIFUL

24 POINT

12 A \$2 25

ADVANCEMENT

18 POINT

18 A \$2 10

BROKERS REPORTS  
RECEIVED 49

12 POINT

32 A \$2 00

PERFORMERS BANQUETED  
875 CORCEOUSLY

AMERICAN TYPE FOUNDERS COMPANY

Contour No 7

72 POINT

3 A 6 a \$7 85

Botanical RECORD

60 POINT

3 A 6 a \$7 80

COURSES Maintained

44 POINT

4 A 8 a \$4 40

POSITION SECURED  
National Finance Reporter

32 POINT

5 A 10 a \$3 35

POPULAR MOVEMENT  
Calisthenic Societies Organized  
1234567890

AMERICAN TYPE FOUNDERS COMPANY

## Contour No 2

48 POINT

3 A \$7 40

MOTIVES

36 POINT

4 A \$3 30

BIRD 8 CLUB

24 POINT

8 A \$1 90

18 POINT

8 A \$1 65

NOTICES  
SENT

NUMEROUS  
WOMEN

## Contour No 3

36 POINT

3 A \$5 75

RINGS

24 POINT

6 A \$4 25

NOT 4 BIG

18 POINT

8 A \$2 25

BRING MORE  
PRODUCE

AMERICAN TYPE FOUNDERS COMPANY



## Contour No 5

---

48 POINT

3 A \$5 40

BEACON

38 POINT

4 A \$4 00

DECORATE

24 POINT

6 A \$2 35

FOREIGN RACES  
65 HORSE

---

## Graphic Series

---

28 POINT

5 A \$3 50

MALDEN GRAPES

24 POINT

8 A \$3 00

FRUITS AND CREAM

22 POINT

7 A \$2 50

TWELVE PEOPLE LOST

18 POINT

8 A \$2 25

BOSTONS SUBWAY CALAMITY  
1 2 3 4 5 6 7 8 9 0

---

AMERICAN TYPE FOUNDERS COMPANY

72 POINT

4 A 5 a \$9 50

STRONG Drinker

60 POINT

4 A 6 a \$7 50

Morning SUNSHINE

54 POINT

4 A 6 a \$7 00

HANDSOME Butterfly

46 POINT

6 A 8 a \$7 00

Watchman EXCELLENT

42 POINT

6 A 9 a \$6 25

DARK Nights

36 POINT

8 A 10 a \$5 75

NUDE Figures

30 POINT

9 A 12 a \$5 00

Lucrative PLACES

24 POINT

10 A 14 a \$4 00

Favorable PASTIME

18 POINT

12 A 18 a \$3 25

IMPETUOUS Philanthropy

12 POINT

20 A 30 a \$3 00

CORRESPONDING 54 Predicaments

60 POINT

4A 5a \$11 00

# POLAR Perils

54 POINT

4A 5a \$8 50

# Land POINTER

48 POINT

4A 6a \$7 75

# TEN Cat

42 POINT

4A 6a \$6 25

# Fat BOYS

36 POINT

5A 7a \$5 75

# Gold MINE

30 POINT

6A 8a \$4 75

# OCEAN Sailor

24 POINT

8A 10a \$4 50

# SKATING Drills

18 POINT

10A 14a \$3 25

# Famous PUBLICATION

12 POINT

16A 24a \$3 00

# CONGRESSIONAL NOTES Bright Entertaining Gentlemen

10 POINT

20A 28a \$2 75

# MARINERS DELIGHTED When Land is Sighted after Six Months

8 POINT

24A 32a \$2 50

# CHARMING AND HANDSOME MAID Exciting Football Games on the Pastime Grounds

6 POINT

26A 36a \$2 25

# PROPOSED NEW AMENDMENTS TO THE Constitution of United States for Emancipation of Base Ball Slaves

1 2 3 4 5 6 7 8 9 0

1 2 3 4 5 6 7 8 9 0

60 POINT

4 A 5 a \$15 00

RICH Man

54 POINT

4 A 5 a \$10 50

Dear GAME

48 POINT

4 A 5 a \$10 00

FRIED Crabs

42 POINT

4 A 6 a \$7 25

Best NEW Dish

38 POINT

5 A 8 a \$6 75

TIN Pan

30 POINT

8 A 8 a \$5 25

Flat RIMS

24 POINT

6 A 10 a \$4 50

Daily RIDES

16 POINT

9 A 13 a \$3 50

NOVEL Whalers

12 POINT

12 A 16 a \$3 00

FISHERMAIDEN  
Handsome Companion

10 POINT

16 A 22 a \$2 75

SAILING EXCURSION  
Midnight Trip Advertised

6 POINT

16 A 24 a \$2 50

ENCAMPMENT CUISINE  
Palatable Dainties Served Gratis  
1 2 3 4 5 6 7 8 9 0

6 POINT

22 A 32 a \$2 25

DELIGHTFUL EVENING PASTIME  
Repairing Fishing and Gunning Equipment  
1 2 3 4 5 6 7 8 9 0

72 POINT

3 A 5 a \$10 00

Golden HOURS

60 POINT

3 A 6 a \$9 00

HOUSE Burning

48 POINT

3 A 4 a \$8 00

Prominent ACTORS

36 POINT

5 A 7 a \$4 75

GRANITE  
Monuments

24 POINT

8 A 11 a \$4 00

CHRISTMAS  
Holiday Presents

18 POINT

11 A 16 a \$3 25

IMPROVEMENTS  
Neatness and Dispatch  
1234567890

12 POINT

18 A 24 a \$3 00

HONORED VISITORS  
Elaborate Receptions Tendered  
1234567890

72 POINT

5 A 6 a \$10 26

SUMMER Fashions

60 POINT

4 A 7 a \$7 50

Extraordinary DISPLAY

54 POINT

6 A 8 a \$6 75

STUMP ORATORS  
Debating Silver Question

48 POINT

8 A 8 a \$6 00

EVENING CONCERT  
Original Burlesque Company

42 POINT

7 A 10 a \$5 50

**GENTLEMEN ESTABLISH**  
**Modern Reform Municipal League**

36 POINT

8 A 12 a \$5 00

**MONUMENT ASSOCIATION**  
**Contributions from Patriotic Volunteers**

30 POINT

10 A 14 a \$4 50

**ORGANIZED BANKING COMPANIES**  
**Autocratic Millionaires Purchasing Securities**

24 POINT

12 A 18 a \$4 25

**PURLOINED KISSES IN TUNNELS**  
**Compressed Sweetness Between Lightning Fleetness**

18 POINT

12 A 24 a \$3 25

**DURABLE AND NEAT**  
**Reversible Seamless Overcoat**  
**1 2 3 4 5 6 7 8 9 0**

12 POINT

22 A 36 a \$3 00

**MUSCULAR ENDURANCE**  
**Entertainments in Gymnastic Contests**  
**1 2 3 4 5 6 7 8 9 0**

72 POINT

3 A 5 a \$9 50

**HOUR Clocks**

60 POINT

3 A 5 a \$8 50

**Antique BARGE**

48 POINT

4 A 7 a \$6 50

**CHIVALROUS  
Mountain Climbers**

42 POINT

5 A 8 a \$6 00

**UNGOVERNABLE  
Conditions Described**



36 POINT

6 A 9 a \$5 50

**ROAMING AMAZONS**  
**Nomadic Habits Unenvied**

30 POINT

7 A 10 a \$4 25

**INGENIOUS MECHANICS**  
**Handsome Lakeview Residence**

24 POINT

8 A 12 a \$4 00

**DOCTORS EDITING JOURNALS**  
**Renowned Medical Manuals Published**

18 POINT

10 A 14 a \$3 25

**DEMANDING EXORBITANT INTEREST**  
**Conventional Inducement of Investment Company**

12 POINT

16 A 20 a \$3 00

**BENEVOLENT GOVERNMENT**  
**Wounded Combatants Pensioned**  
**1 2 3 4 5 6 7 8 9 0**

10 POINT

20 A 26 a \$2 75

**ENTERTAINING SOCIETY MAIDENS**  
**Admiring Juvenile Comedians Simplicity**  
**1 2 3 4 5 6 7 8 9 0**

Atlanta Series

48 POINT

4 A \$10 00

SOURS

42 POINT

4 A \$7 25

MOVER

36 POINT

4 A \$6 75

MINDING

30 POINT

5 A \$5 00

GERALINE

24 POINT

6 A \$4 50

GRAB ❖ BAGS

18 POINT

8 A \$3 50

❖ STING ❖

14 POINT

9 A \$3 25

❖ CROAKS ❖

12 POINT

12 A \$3 00

GOOD ❖ DOGS

10 POINT

18 A \$2 75

SWEET ❖ MUSIC

8 POINT

20 A \$2 50

❖ CALLED · LOUDEST ❖  
1234567890

6 POINT

28 A \$2 25

\* COURAGEOUS · DEFENDER \*  
1234567890

AMERICAN TYPE FOUNDERS COMPANY

# Victoria Series

48 POINT

5 A \$8 50

VICTORIA

42 POINT

6 A \$7 25

CONSTRUE

36 POINT

6 A \$6 75

✻ SPURNED ✻

30 POINT

7 A \$5 00

CAPITAL · RING

24 POINT

6 A \$4 50

✻ COMFORTS ✻

18 POINT

10 A \$3 50

SPARROWS

14 POINT

12 A \$3 25

CONJUNCTIVE

12 POINT

16 A \$3 00

KINDLY ✻ WORDS

10 POINT

20 A \$2 75

TENDER ✻ AFFECTION

8 POINT

26 A \$2 50

✻ CHEERING + RECEPTION ✻  
1234567890

6 POINT

36 A \$2 25

\* UNRULY + CHILDREN + PUNISHED \*  
1234567890

AMERICAN TYPE FOUNDERS COMPANY

Iroquois Series

36 POINT

3 A 6 a \$6 50

➤ **HOUND** ➤

**Rough Antics**

30 POINT

4 A 6 a \$5 50

**ENTOMBED**

**Staunch Heroes**

24 POINT

5 A 10 a \$4 50

➤ **GUARDIANS** ➤

**Defending Entrance**

16 POINT

6 A 12 a \$3 50

**SMART LEADER**

**Promotes Valiant Soldier**

12 POINT

10 A 16 a \$2 40

**PATRIOTIC**  
**Farmers Enlisted**

10 POINT

14 A 20 a \$2 35

**RECEPTIONS**  
**Welcome Conqueror**

6 POINT

15 A 30 a \$2 10

**NOTABLE CITIZENS**  
**Greeting Foreign Diplomat**  
1 2 3 4 5 6 7 8 9 0

6 POINT

20 A 40 a \$2 40

**CRIMINAL NEGLIGENCE**  
**Reporters Disregard Summons**  
1 2 3 4 5 6 7 8 9 0

AMERICAN TYPE FOUNDERS COMPANY

**Iroquois Condensed**

36 POINT

5 A 8 a \$4 90

**HISTORICAL  
Southern Metropolis**

30 POINT

6 A 9 a \$4 25

**IMPROVEMENTS  
Mechanical Department**

24 POINT

8 A 12 a \$3 75

**AMERICAN CONSULS  
Diplomatic Services Rendered**

18 POINT

10 A 18 a \$3 00

**OCEANIC MINING COMPANY  
Natural Resources Become Exhausted**

12 POINT

12 A 20 a \$2 75

**MODERATE PRICES  
Broken Furniture Repaired**

8 POINT

20 A 30 a \$2 25

**REWARDING CONTRACTORS  
Seventeen Superior Mechanics Engaged  
1234567890**

10 POINT

15 A 25 a \$2 50

**OUTLAWS CAPTURED  
Determined Railway Conductor**

8 POINT

25 A 35 a \$2 00

**DEVASTATION EVERYWHERE  
Suburban Residences Destroyed by Tidal Wave  
1234567890**

**AMERICAN TYPE FOUNDERS COMPANY**

Quaint Roman No 2

48 POINT

4 A 5 a \$11 00

Great RISE

36 POINT

4 A 8 a \$8 50

ANCIENT  
Nubian Builder

24 POINT

6 A 8 a \$5 00

HISTORIANS  
Charming and Reliable

18 POINT

8 A 10 a \$4 50

MODERN CUSTOMS  
Inaugurated by Academician

12 POINT

14 A 16 a \$3 25

ENDORSEMENT  
Rejoicing Projectors  
I 2 3 4 5 6 7

10 POINT

14 A 18 a \$3 00

MEXICAN EDITION  
Original Fashion Designs  
I 2 3 4 5 6 7 8 9 0

AMERICAN TYPE FOUNDERS COMPANY

48 POINT

3 A 5 a \$6 50

NORTH TURK  
Young King 9

36 POINT

4 A 6 a \$5 00

RUSKINS WORKS  
Valuable Books 7

24 POINT

8 A 10 a \$4 00

GREAT NORTH AMERICA  
Includes more Territory 6

18 POINT

11 A 16 a \$3 25

MOUNT HENRY  
French Islands 4

12 POINT

25 A 32 a \$3 00

STANDARD TRANSFER  
Thursday and Saturday 9

24 POINT with 48 Point Initials

3 A 8 A 12 a 89 65

LIVELY KID  
Omnivorous Tendencies  
Garden Rambler

18 POINT with 36 Point Initials

4 A 10 A 15 a 87 45

RUSTIC SERVICE  
Water-Pails and Coal-Shovels  
Household Utensils

12 POINT with 24 Point Initials

6 A 14 A 22 a 85 30

SOMNOLENT & CO  
Fabricators of Air-Castles and Hammocks  
Mattresses and Night-Caps  
1 2 3 4 5 6 7 8 9 0



Longfellow Series

72 POINT

3 A 6 a \$12 00

Broken Carriage

60 POINT

4 A 9 a \$11 00

Educate the Minor

54 POINT

4 A 9 a \$10 00

Theorists

46 POINT

4 A 10 a \$9 00

Marriages

42 POINT

4 A 10 a \$8 00

Researches

36 POINT

4 A 12 a \$7 00

Enchantment

30 POINT

5 A 14 a \$6 00

Warlike Errand

24 POINT

7 A 16 a \$5 00

Advanced Thinkers

16 POINT

9 A 22 a \$4 50

Removing the Wreckage

12 POINT

14 A 40 a \$4 00

Expedition Starting for Iceland

10 POINT

14 A 40 a \$3 50

Surveyors Dispel Senseless Theories

8 POINT

14 A 40 a \$3 00

Stupendous Undertakings Accomplished

1234567890

1234567890

60 POINT

3 A 5 a \$9 60

Grand Jaunts

48 POINT

3 A 6 a \$7 60

Beautiful Scenes

36 POINT

4 A 8 a \$6 20

Gorgeous Landscape

30 POINT

5 A 10 a \$5 75

Crossing the Mountains

24 POINT

6 A 12 a \$5 05

Tourists Enjoying the Sport

18 POINT

6 A 16 a \$4 35

Running Up Hills and Down Valleys

1234567890

60 POINT

3 A 5 a \$10 65

OUR Guard

48 POINT

4 A 6 a \$8 35

Hold the FORT

36 POINT

5 A 8 a \$6 30

GRAND Manœuvre

30 POINT

6 A 9 a \$5 15

STOUT  
Conscript

24 POINT

8 A 12 a \$4 50

DARING  
Skirmishers

18 POINT

12 A 18 a \$4 10

AMAZONS  
Robust Warriors  
123456

12 POINT

20 A 30 a \$3 80

UNBLUSHING  
Regimental Daughters  
12345678

MORTISED INITIAL LETTERS

C F L T

ACCOMPANY EACH FONT

AMERICAN TYPE FOUNDERS COMPANY

46 POINT

4 A \$5 25

MONUMENTS

42 POINT

5 A \$4 75

GRAND HEIGHT

36 POINT

5 A \$4 25

DUSTER AND BRUSH

30 POINT

6 A \$3 50

INCREASE EXERTION

24 POINT

6 A \$3 25

BEAMS REMAIN WHITE

20 POINT

9 A \$2 50

EXACT FORCE

18 POINT

10 A \$2 50

MAIDS KNOWN

12 POINT

16 A \$2 25

NUMEROUS REPORTS

10 POINT

20 A \$3 00

COMPLIMENTS REQUIRED

6 POINT

26 A \$1 75

MAGNIFICENT AND EXTRAORDINARY

6 POINT

26 A \$1 50

SPECIAL RATES, FOR BOYS AND GIRLS

<1234567890>

<1234567890>

60 POINT

5 A \$6 50

REQUIREMENT

54 POINT

5 A \$5 50

BRANCH ENGINE

48 POINT

5 A \$4 75

MOURNING HOURS

42 POINT

6 A \$4 25

DESCRIBE

36 POINT

6 A \$4 00

REDUCTION

30 POINT

9 A \$3 50

AMUSEMENTS

24 POINT

12 A \$3 25

CONSEQUENCES

20 POINT

16 A \$3 00

GENERAL RECORDS

18 POINT

18 A \$2 75

MORNING TELEGRAMS

12 POINT

25 A \$2 25

MANUFACTURING DEPARTMENTS

10 POINT

30 A \$2 00

REPAIRING ELECTRICAL INSTRUMENT

8 POINT

36 A \$1 75

ENORMOUS BARGAINS IN ARTISTIC FURNITURE

6 POINT

36 A \$1 50

MENAGERIES CONTAIN SOME REMARKABLE FEATURES

1 2 3 4 5 6 7 8 9 0

1 2 3 4 5 6 7 8 9 0

72 POINT

9 A \$7 25

VENTURESOME YOUNGSTER

60 POINT

12 A \$6 75

DEMANDS QUICK EXPERIMENTS

54 POINT

12 A \$6 00

AUTHORIZATION

48 POINT

12 A \$5 25

GOVERNMENTAL

42 POINT

14 A \$4 50

RESULT OBTAINED

36 POINT

16 A \$4 00

CRANKS WANDERING

30 POINT

16 A \$3 50

STATESMEN ASTOUNDED

24 POINT

20 A \$3 00

NOCTURNAL AMUSEMENTS

16 POINT

26 A \$2 75

LARGE CONTRIBUTIONS REQUESTED

16 POINT

30 A \$2 50

DANGEROUS HOMEWARD PROMENADE

12 POINT

40 A \$2 25

ANCIENT SCIENCES AND MODERN ETIOLOGY  
1 2 3 4 5 6 7 8 9 0

10 POINT

46 A \$2 00

FOREIGN QUESTIONS NEVER INTRODUCED BEHINDHAND  
1 2 3 4 5 6 7 8 9 0

72 POINT

9 A 12 a \$13 50

Somnambulistic Excursion

60 POINT

12 A 18 a \$12 50

Modern Contrivance Desirable

54 POINT

12 A 16 a \$10 75

Remonstrations

48 POINT

12 A 16 a \$9 00

Unconscientious

42 POINT

14 A 18 a \$8 25

Generous Brothers

36 POINT

18 A 20 a \$7 00

Confidence Rewarded

30 POINT

16 A 20 a \$6 00

Government Examination

24 POINT

20 A 24 a \$5 00

Unbroken Promise Recorded

18 POINT

28 A 32 a \$4 75

Industrious Manufacturers Rewarded

16 POINT

30 A 34 a \$4 00

Americans Sending Largest Contribution

12 POINT

40 A 44 a \$3 75

Attention Given to Business Before Pleasure

10 POINT

48 A 50 a \$3 25

Revised Histories of Celebrated Discoveries Completed

1 2 3 4 5 6 7 8 9 0

1 2 3 4 5 6 7 8 9 0

60 POINT

3 A 5 a \$7 95

Riverside Tramways

46 POINT

4 A 6 a \$6 70

Advantageous Movement

42 POINT

5 A 10 a \$6 00

Portraying Domestic Industry

30 POINT

6 A 16 a \$5 10

Pictures of the Gigantic  
Columbian Exposition Viewed Hourly

24 POINT

6 A 26 a \$4 40

Celebrating the Landing of Columbus  
Display of American and European Handicraft

1 2 3 4 5 6 7 8 9 0



Webster Series

36 POINT

3 A 6 a \$5 00

ENGINEERING  
Mechanical Lessons

24 POINT

6 A 10 a \$4 00

GRAND BANQUET  
Visiting European Statesmen

18 POINT

8 A 14 a \$3 25

BUILDER AND MECHANIC  
Constructors of Famous Modern Dwellings  
Satisfaction Guaranteed

12 POINT

12 A 22 a \$3 00

WONDERFUL ELECTRIC MACHINERY  
Examinations by the General Public Particularly Desired  
Exhibition at Manufactory

10 POINT

16 A 22 a \$2 75

BEAUTIFUL HOLIDAY PRESENTS OFFERED  
Customers are Respectfully Requested to Examine these Articles  
1234567890

AMERICAN TYPE FOUNDERS COMPANY

36 POINT

4A 8a \$6 20

Famous SIGNS

30 POINT

6A 8a \$5 35

BREAD Producers

24 POINT

7A 10a \$4 05

Inconsistent REMARKS

18 POINT

10A 14a \$3 60

Railroad FREIGHT Contracts

14 POINT

12A 18a \$3 25

SUBLIME SHOWING  
Annual Parisian Trimming Display

12 POINT

15A 22a \$3 00

UNBIASED  
Decision Rendered

10 POINT

18A 26a \$2 90

SEMPER IDEM  
Sunshine after Storm

8 POINT

20A 32a \$2 60

CONNOISSEURS  
Spacious Pothouse Patrons  
12345678

6 POINT

22A 35a \$2 50

MINERAL DEPOSITS  
Auriferous Dumping Grounds  
1234567890

## Unique Celtic Condensed

38 POINT

4 A 6 a \$4 25

Enthusiastic HORDES

30 POINT

6 A 8 a \$3 75

SPORTIVE Demonstration

24 POINT

8 A 10 a \$3 25

WINSOME VIRGINS  
Humorist Banishing Melancholy

18 POINT

12 A 16 a \$3 00

ORATORICAL REFORMERS  
Smockfrocked Blatherskites Gesticulating

12 POINT

18 A 30 a \$2 75

DARING SEARCH  
Returned Seamen Rejoicing  
after a Perilous Expedition

8 POINT

25 A 38 a \$2 25

MACHINES PERFECTED  
Labor-Saving Apparatus Guaranteed  
Complete with all the Latest Devices  
1 2 3 4 5 6 7 8 9 0

10 POINT

20 A 34 a \$2 50

FOREIGN VIEWS  
Memorable Scenes Reproduced  
by the New Electric Verascope

8 POINT

30 A 45 a \$2 00

EXPEDITION TO WONDERLAND  
Language Fails to Describe this Wonderful Isle  
which is Situated in the North Atlantic Ocean  
1 2 3 4 5 6 7 8 9 0

AMERICAN TYPE FOUNDERS COMPANY

72 POINT

3A 5a \$10 00

Reform School

60 POINT

4A 5a \$9 20

Fraternal Artists

48 POINT

4A 5a \$8 50

Carnival Excursions

36 POINT

6A 8a \$5 00

Merchandise Undervalued

24 POINT

8A 10a \$4 00

Indisputable Fence-rail Philosopher

18 POINT

12A 16a \$3 00

Unfounded Aristocracy Degenerating Hypocrites

12 POINT

14A 20a \$3 00

Merry Midway Plaisance Girl  
1 2 3 4 5 6 7 8 9 0

10 POINT

18A 28a \$2 75

Proposed Aerial Trips Postponed  
1 2 3 4 5 6 7 8 9 0

48 POINT

3 A 4 a \$4 55

PENSIONERS  
Twelve-day Service

38 POINT

4 A 8 a \$3 80

MONEY LOANING  
Government Pawnshops

24 POINT

8 A 10 a \$3 00

RAILROAD EXCURSION  
Around the Continent Gratuitously

18 POINT

10 A 14 a \$2 45

INDUSTRIAL  
Proceeds Distributed  
12345678

12 POINT

16 A 25 a \$2 25

TELEGRAPHING  
Messages Between Gallants  
12345678

**Victoria Italic**

24 POINT No 1

8 A \$3 75

*EXCURSIONIST*

24 POINT No 2

8 A \$3 25

*SEVERE STORMS*

18 POINT No 1

12 A \$3 25

*MIDNIGHT RAMBLE*

18 POINT No 2

12 A \$2 75

*SUBURBAN RESIDENCE*

12 POINT No 1

16 A \$2 50

*DECOROUS SPINSTERS  
MUTUAL ADORATION SOCIETY*

12 POINT No 2

16 A \$2 25

*LUDICROUS AND ANNOYING  
SUDDEN BURSTING OF PANTALOONS*

12 POINT No 3

16 A \$2 00

*FLOWER PLANTS  
GERANIUM ADMIRER*

6 POINT No 1

30 A \$2 50

*ROYAL VISITORS  
SALUTING THE FLAGSHIP*

6 POINT No 2

30 A \$2 25

*HUMOROUS ANECDOTES  
GUARDED SECRETS OVERHEARD*

6 POINT No 3

30 A \$2 00

*ROBINSON CRUSOE OUTDONE  
HISTORY OF SINBAD THE MARINER*

6 POINT No 4

36 A \$2 00

*HARMLESS SIMPLETONS RAMPANT  
VICTIMS OF CHEAP AND TRASHY NOVELS  
1234567890*

6 POINT No 5

36 A \$2 00

*CYCLONIC WINDS RAGING FIERCELY  
DESTRUCTIVE STORM DEMOLISHING PROPERTY  
1234567890*

*LINE STRICTLY ACCURATE SIGN*

AMERICAN TYPE FOUNDERS COMPANY

## Elandkay Series

16 POINT NO 29

12A \$2 00

SPECTATORS AMAZED  
NOVEL ELECTRICAL STATIONS

18 POINT NO 28

14A \$1 75

GORGEOUS PRODUCTIONS  
DELICATE AND ARTISTIC PORCELAIN

12 POINT NO 27

16A \$1 50

BEAUTIFUL FRIGATES SAILED  
DIRECT FROM SPAIN TO BOSTON HARBOR

12 POINT NO 26

16A \$1 50

DASHING AND FANCY ATHLETES  
RUNNING GRACEFULLY OVER ASPHALT AVENUES

12 POINT NO 25

24A \$1 50

TIMBERLAND AND HARDWOOD COMPANY  
MANUFACTURERS AND JOBBERS IN WOODEN MERCHANDISE

6 POINT NO 24

30A \$1 50

LAUGHING BABBLING BROOK  
SPRING AND SUMMER ARE COMING

6 POINT NO 23

30A \$1 50

PRESENT DIFFICULTY ACCEPTED  
MOONLIGHT RAMBLINGS ON THE BEACH

6 POINT NO 22

40A \$1 25

PENSIVELY LOOKING BACKWARD  
EXALTED THOUGHTS AND WORTHY BEHAVIOR

1234567890

6 POINT NO 21

40A \$1 25

COLORS SATINS AND LINEN GOODS  
ARRIVING DAILY PER STEAMSHIP INTERNATIONAL

1234567890

MMMMMMMMMMMMMMMMMMMM

AMERICAN TYPE FOUNDERS COMPANY

Florentine Old Style No 2

72 POINT

4 A 5 a \$9 50

NOVICE  
White Frost

60 POINT

4 A 5 a \$9 00

BRONTERN  
Florentine 85

48 POINT

5 A 5 a \$7 00

AMERICANS  
Desired 9 Efforts

AMERICAN TYPE FOUNDERS COMPANY



## Florentine Old Style No 2

36 POINT

6 A 8 a \$6 00

POPULARITY  
Increased & Demands

24 POINT

10 A 10 a \$5 00

CONSIDERED HOSTILITY  
Distinguished \$26 Repudiators

18 POINT

15 A 14 a \$4 50

TWENTIETH ADMINISTRATION  
Presidents Message Before the House

12 POINT

20 A 24 a \$3 75

Like a speck of sunshine  
Flits the butterfly  
Like a little cloudlet  
Hung up in the sky

6 POINT

30 A 32 a \$2 75

It grew where Nature wild and grand  
Had known no fawdry Art  
But with its beauty in the land  
Had won the poet's heart

10 POINT

25 A 32 a \$3 25

Winging o'er the children  
Like a winged flower  
Form of fairest beauty  
In the summer hour

6 POINT

36 A 40 a \$2 50

See the children watch it  
From the flowery ground  
Winged bit of sunshine  
Circling round and round

AMERICAN TYPE FOUNDERS COMPANY

Elzevir Gothic

46 POINT

3 A 6 a \$8 00

↳ CHARM ↳  
Roman Guard

36 POINT

5 A 9 a \$6 00

MONUMENTS  
Grandeur Described

30 POINT

6 A 12 a \$5 50

↳ COUNCILMANIC ↳  
Independent Convention

24 POINT

8 A 16 a \$5 00

MOUNT VESUVIUS  
Gorgeous Palaces Destroyed  
Violent Eruption

AMERICAN TYPE FOUNDERS COMPANY

18 POINT

12 A 24 a \$4 50

**NATIONAL PREROGATIVE**  
**Liberal Reform Movements Indorsed**  
**Municipal Resolution**

14 POINT

15 A 30 a \$4 00

**FAMOUS ELOCUTIONISTS ENTERTAIN**  
**Distinguished Orators Receive Congratulations**  
**Linguistic Powers Unsurpassed**

12 POINT

18 A 38 a \$3 25

**£ NATIONAL CONVENTION CONSIDERED £**  
**International Monetary Questions Frequently Discussed**  
**Organization Committee Reports**

10 POINT

20 A 40 a \$3 00

**HANDSOME PREMIUMS AWARDED COMPETITORS**  
**Collection of Botanical Specimens and Delicate Wild Flowers**  
**Floricultural and Horticultural Exhibition**

8 POINT

22 A 44 a \$2 75

**£ DESIROUS FOR THE IMPROVEMENT OF MANKIND £**  
**Advocating Protection for the Honest and Industrious from the Wiles of Iniquity**  
**Distributing Tracts in all Parts of the World**

8 POINT

25 A 50 a \$2 50

**MORALS OF THE GENERAL PUBLIC SHOW A CHANGE FOR THE BETTER**  
**Progress of Civilization Since the Introduction of the Common Weal Society has been Wonderful**  
**Remarkable Decrease of Crime Since the Advent of this Order**

1 2 3 4 5 6 7 8 9 0

**AMERICAN TYPE FOUNDERS COMPANY**

## THE ORIGIN OF ROMAN TYPES, WITH CHANGES BEFORE AND AFTER REACHING ENGLAND.



THE Italian scribes of the fifteenth century were famous for their beautiful manuscripts, written in a hand entirely different from the Gothic of the Germans, or the Secretary of the French and Netherlands calligraphers. It was only natural that the first Italian printers, when they set up their press at Subiaco, should form their letters upon the best model of the national scribes. The Cicero de Oratore of 1465 is claimed by some as the first book printed in Roman type, although the character shows that the German artists who printed it had been unable wholly to shake off the traditions of the pointed Gothic school of typography in which they had learned their craft. The type of the Lactantius, and the improved type of the works subsequently printed by Sweynheim and Pannartz at Rome, as well as those of Ulric Hahn, were, in fact, Gothic-Romans; and it was not till Nicholas Jenson, a Frenchman, in 1470, printed his Eusebii Praeparatio at Venice, that the true Roman appeared in Italy, which was destined to become the ruling character in European Typography. Fournier and others have considered that Jenson derived his Roman letter from a mixture of alphabets of various countries; but it is only necessary to compare the Eusebius with the Italian manuscripts of the period, to see that no such elaborate selection of models was necessary or likely. Jenson's font is on a body corresponding to English. The font is round and clear, and differing in fashion only from its future progeny. The capital alphabet consists of twenty-three letters (J, U, and W not being yet in use); the lower case alphabet is the same except that the u is substituted for the v, and in addition there is a long i, and the diphthongs. To complete the font, there are fifteen contractions, six double letters, and three points, the . : ? making seventy-three punches in all. Jenson's Roman letter fell after his death into the hands of a firm of which Andrea Torresani was head. Aldus Manutius subsequently associated himself with Torresani, and, becoming his son-in-law and heir, eventually inherited his punches, matrices, and types. The Roman fonts of Aldus were eclipsed by his Italic and Greek, but he cut several fine alphabets, Renouard mentions eight distinct fonts between 1494 and 1558. Roman type was adopted before 1473 by Mentelin of Strasburg, whose beautiful letter placed him in the front rank of the German printers. Gunther Zainer, who settled at Augsburg in 1469, after printing some works in the round Gothic, also adopted, in 1472,

ORNAMENT NO 4299  
\$ 2 00

## Jenson Old Style

10 POINT

25 A 30a \$3 00

the Roman of the Venetian School, fonts of which he is said to have brought direct from Italy. The German name of Antiqua, applied to the Roman character, has generally been supposed to imply a reluctance to admit the claim of Italy to the credit of introducing this style of letter. As, however, the Italians themselves called the letter the Lettera Antiqua tonda, the imputation against Germany is unjust. The French, Dutch, and English called it Roman.

### ROMAN CHARACTERS THE FIRST TYPES USED IN FRANCE, IN THE YEAR 1470.\*\*\*

**F**RANCE received printing and the Roman character at the same time, the first work of the Sorbonne press in 1470 being in a handsome Roman letter about Great Primer in size, with a slight suggestion of Gothic in some of the characters. Gering, a German himself, and his associates, had learned their art at Basle, but cut, and probably designed, their own letter on the best available models. Their font is rudely cast, so that several of their words appear only half-printed in the impression, and have been finished by hand. It has been stated erroneously, by several writers, on the authority of Chevillier, that their font was without capitals. The font is complete in that respect, and Chevillier's expression, "lettres capitales," as he himself explains, refers to the initial letters for which blank spaces were left to be filled in by hand. Besides the ordinary capital and lower-case alphabets, the font abounds in abbreviations. This letter was used in all the works of the Sorbonne press, but when Gering left the Sorbonne and established himself at the Soleil d'Or, in 1473, he made use of a Gothic letter. In his later works, however, new and greatly improved fonts of the Roman appear. Jodocus Badius, who by some is erroneously supposed to have been the first who brought the Roman letters from Italy to France, did not establish his famous Prelum Ascensianum in Paris till about 1500, when he printed in Roman types—not, however, before one or two other French printers had already distinguished themselves in the introduction of printing from the adopted Roman characters. The French quickly recognized the opportunities of printing, but were slow in improving the shapes of the Roman letter.

ORNAMENT No 4239 \$1 00

AMERICAN TYPE FOUNDERS COMPANY

## Jenson Old Style

12 POINT

18 A 30a \$3 25

ROMAN WAS FIRST USED IN THE NETHERLANDS ABOUT 1472. ❁❁❁



ROMAN was introduced into the Netherlands by Johannes de Westfalia, who, it is said, brought it from Italy in the year 1472. He located at Louvain, and after a number of works in semi-Gothic, published in 1483 an edition of Aeneas Silvius in the Italian letter. His font is elegant, and rather a lighter face than most of the early Roman fonts of other countries. This printer appears to have been the only one in the Low Countries who used this type during the fifteenth century; nor was it till Plantin, in 1555, established his famous press at Antwerp, that the Roman attained to any degree of excellence. But Plantin, and after him the Elzevirs, were destined to eclipse all other artists in their execution of this letter, which in their hands became a model for the typography of all civilization. It should be mentioned, however, that the Elzevirs are not supposed to have cut their own punches. The Roman types which they made famous, and which are known by their name, were cut by Christopher Van Dijk, the form of whose letter was subsequently adopted by English printers with only a few immaterial changes.

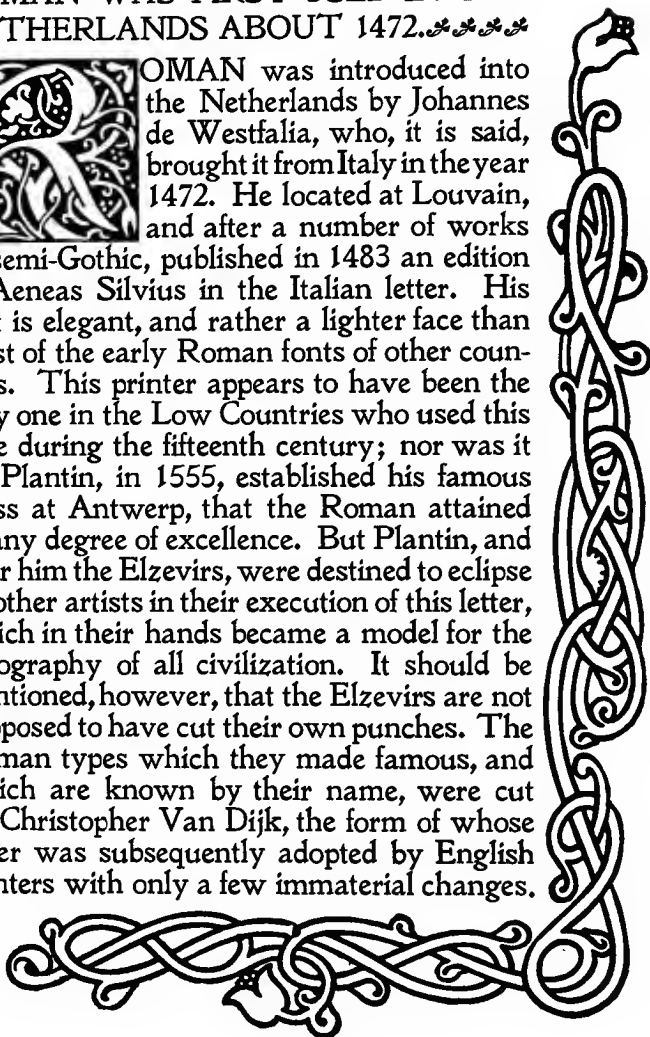

ORNAMENT No 4269 \$1 75

AMERICAN TYPE FOUNDERS COMPANY

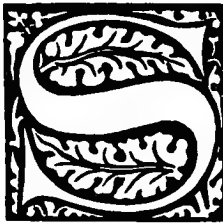

SWITZERLAND distinguished itself by the Roman letter of Amerbach of Basle, and still more so by the beautiful fonts used by Froben of the same city, who between 1491 and 1527 printed some of the finest books then known in Europe. Christopher Froschouer of Zurich, about 1545, made use of a peculiar and not unpicturesque form of the Roman letter, in which the round sorts were thickened, after the Gothic fashion, at their opposite corners, instead of at their opposite sides. ❀ ❀ ❀

### FIRST INTRODUCED IN ENGLAND.



THE Roman was first introduced in England in 1518 by Richard Pynson. This printer's Norman birth, and his close relationship with the typographers of Rouen, together with his supposed intimacy with the famous Basle typographer Froben, make it highly probable that he procured his letter abroad, or modelled it on that of some of the celebrated foreign printers of his day. The font, though neat and bold in appearance, displays considerable irregularity in the casting, and has many contractions. ❀

ORNAMENT NO 4243  
\$2 00

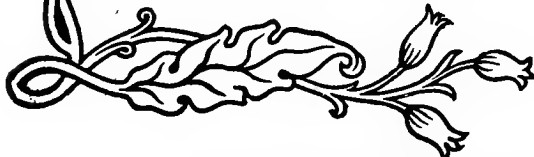





THE Roman made its way rapidly in English typography during the first half of the sixteenth century, and in the hands of such artists as Faques, Rastell, Wyer, Berthelet, and Day, maintained an average excellence. But it rapidly degenerated, and while other countries were dazzling Europe by the brilliancy of their impressions, the English Roman letter went from good to bad, and from bad to worse. While Claude Garamond in France was carrying into noble practice the theories of the form and proportion of letters set out by his master, Geofroy Tory; while the Estiennes at Paris, Sebastian Gryphe at Lyons, Froben at Basle, Froschouer at Zurich, and Christopher Plantin at Antwerp, were moulding their alphabets into models that were to become classical, English printers, manacled body and soul by their patents and monopolies and state persecutions, achieved nothing with the Roman type that was not retrograde. For a time a struggle appears to have existed between the Black-letter and the Roman for the mastery of the English press, and at one period the curious spectacle was presented of mixed fonts of the two. ❁ ❁ ❁ ❁ ❁ ❁ ❁ ❁ ❁ ❁ ❁ ❁



## THE FIRST ENGLISH

Bible ever printed in a Roman type was issued by Bassenpyne in Edinburgh, in 1576. From the early days of Scotch typography a steady trade in type and labor was maintained between Holland and Scotland; and he exhibited the Dutch Romans in his specimen pages. 



## ANCIENT PRINTERS

Were liberal in their ideas and cut their letters with an eye to artistic beauty. But as printing ceased to be an art, and became a trade, economical considerations suggested a distortion. 



## SMALL FACES

The compressed Roman letters of French, Italian, and in a great number of cases the Dutch printers, were not wholly bad. 34

## SEDAN BODY

The beautiful Sedan books of Jannon gave their name to the microscopic type.  

# DESIGNING

The date at which  
we quit the survey  
is not glorious  

# ORIGINAL

English founders  
cast Diamond as  
far back as 1700

FOUNDERS  
Original model  
artistic faces 13

ROMANS  
Grand pieces  
third year 25

# Initials and Embellishments

NO 4265 \$1 50

— A —

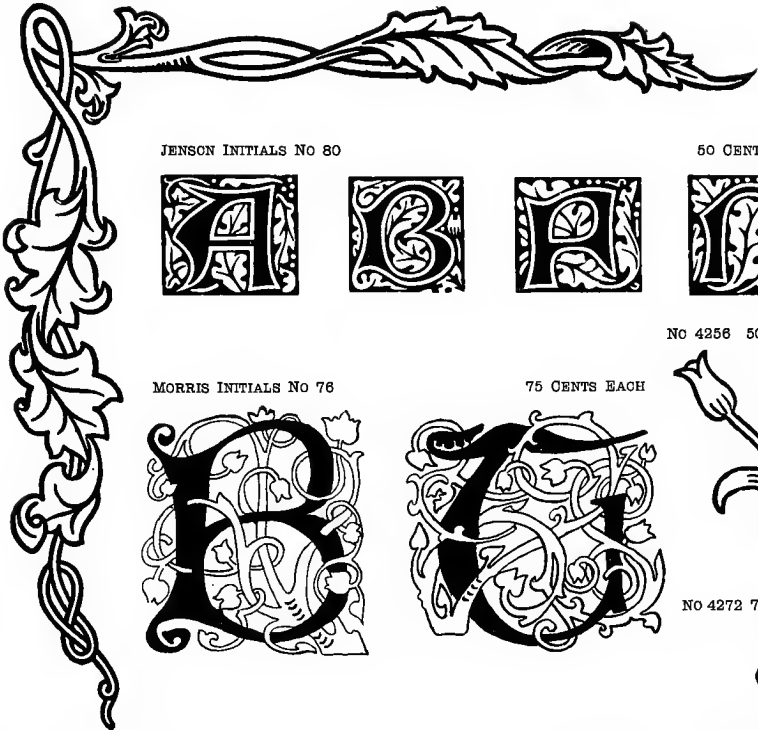

JENSON INITIALS No 80

50 CENTS EACH



NO 4256 50 CENTS

MORRIS INITIALS No 76

75 CENTS EACH

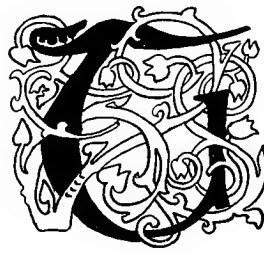

NO 4272 75 CENTS

MORRIS INITIALS No 77

60 CENTS EACH



MORRIS INITIALS No 78

50 CENTS EACH



*A large variety of Embellishments and Initials made. Specimens on application*

AMERICAN TYPE FOUNDERS COMPANY

*Our Reports*  
*remunerated*  
**SECURE**

*Roman Letters*  
*were invented*  
**MODERN**

*German printers  
used bold Black  
Type which was  
PRINTED*

*In early history the  
first type Printers  
in the Monasteries  
RECEIVED*

42 POINT

4 A 6 a \$7 25

*Americans Compare*  
**COMPROMISE**

36 POINT

4 A 8 a \$5 50

*Receive News Quickly*  
**INSTRUCTORS**

30 POINT

5 A 10 a \$5 00

*Modest Antiquarians Return*  
**ANTIQUAE COINERS**

24 POINT

6 A 15 a \$4 50

*Nations in which the human race  
has freely contributed to educational*  
**CHARMING LECTURER**



## Jenson Italic

18 POINT

10 A 25 a \$4 00

*The accomplished philosopher and man of letters, to whom the great names of all who have been eminent in ancient and modern times, in all the nations in which the race of man has*  
**STOCK OF HUMAN WISDOM**

12 POINT

18 A 40 a \$3 25

*Pride and humility are always relative terms. They imply comparisons of some sort with an object higher or lower; and the same mind, with actual excellence exactly the same, and with the same comparative attainments in every one around, may thus be either proud or humble, it looks above or it looks beneath*  
**CHARACTER OF MIND PREDOMINATED PRIDE**

10 POINT

20 A 45 a \$3 00

*Of two minds possessing equal excellence, which is the more noble: that which, however high the excellence attained by it, has still some nobler excellence in view, to which it feels its own inferiority; or that which, having risen a few steps in the ascent of intellectual and moral glory, thinks only of those beneath, and rejoices in an excellence which would appear to it of little value if only it lifted a single glance to the perfection above? Yet this*  
**INNUMERABLE GRADATIONS BEING TRACED**

8 POINT

20 A 50 a \$2 75

*From the Almighty Being, who is the source of all life, to the lowest of his creatures, what innumerable gradations may be traced, even in the ranks of excellence on our own earth, each being higher than that beneath and lower than that above; and thus, all to all, objects at once of pride or humility, according as the comparison may be made with the greater or with the less. Of two minds then, possessing excellence, which is the more noble: that which, however high the excellence attained by it, has still some nobler excellence in view, to which it feels its own inferiority; or that which having risen a few steps in the ascent of intellectual and moral glory, thinks only to*

**PRIDE AS A CHARACTER OF SELF-COMPLACENT EXULTATION**

1 2 3 4 5 6 7 8 9 0

AMERICAN TYPE FOUNDERS COMPANY

72 POINT

4A 5a \$17 00

Standards

60 POINT

4A 5a \$12 25

Demonstrate

54 POINT

4A 5a \$10 25

Musicians  
Enchantment

48 POINT

4A 5a \$7 75

Senatorial  
Administrative

42 POINT

4A 6a \$7 25

Enthusiastic  
Soldiers Marched

36 POINT

5A 8a \$5 50

Cultivators  
Mirthful Harvesters

30 POINT

6A 10a \$5 00

✿ Legerdemain ✿  
Necromancer Rehearsing

24 POINT

6A 15a \$4 50

Beautiful Landscape  
Realistic Paintings Exhibited

18 POINT

8A 25a \$4 00

Rambling Tourist Enchanted  
Inspiring Mountain Scenery in Autumn

## Satanick Series

.2 POINT

10 A 35 a \$3 25

**A**MERICANS have realized within recent years that there are some provinces by the sea, located as the mariners would say nor'-nor' east of us, which for wholesome climate and varied sights offer a greater wealth of attractions during summer days than is possessed by any other nearby region. Geographers have given to them the name of Maritime Provinces

8 POINT

15 A 50 a \$2 75

**T**HE SHOOTING on Prince Edward Island during the season is exceedingly good, and wild geese, brant, duck, partridge, woodcock and snipe are to be found in abundance, while such streams as the Monce, the Dunk, the Pierrejaques, the Miminigash, the Kildare, Tignish and others, teem with trout and salmon. From any one of the little seaside towns on Prince Edward Island one may have within a half-hour or hour's sail an abundance of mackerel and deep-sea fishing. \* \* \* The island constitutes the smallest of the provinces, but maintains equal dignity with the greatest, having its own provincial government, comprising a governor and parliament, and sending six commoners to

10 POINT

12 A 40 a \$3 00

**W**ESTWARD from Windsor the country takes on a different character. Barren rocky slopes have given way to fertile fields. The hills have drawn apart and the Gasperau Valley spreads out its verdure-covered meadows and luxuriously-foliaged orchards on every hand. Over to the right sparkles the Bay of Minas, and outlined on the horizon is grand old Blomidon, that majestic bastion, keeping faithful sentinel, as in the days of Evangeline, over the turbulent waters, which rise and fall with mighty force at its rocky base, guarding the peaceful valley

6 POINT

15 A 50 a \$2 50

**F**ROM HALIFAX fishing trips may be taken either by the several coach lines along the coast, or by private conveyances, which are to be obtained at reasonable cost. There is good sport along the western shore all the way to Chester and Gold River. Indian River, twenty-one miles from Halifax, and Ingram River, distant twenty-five miles, are also good points, as is Grand Lake. At St. Margaret's Bay may be found an old-fashioned inn and guides. Indian Lake, about eight miles from Halifax, on the Prospect Road, Peters Lake, Spruce Hill Lake and Nine Mile River are good points for the Spring and Summer sport. \* \* \* It is impossible, in an article of this length, to give a list of all the favorite places for sport, but this information can readily be secured in Halifax or any of the larger or smaller towns. No reference to fishing in the Provinces would, however, be complete without mention of that most famous of all salmon waters, the Margaret River, in Cape Breton

AMERICAN TYPE FOUNDERS COMPANY

72 POINT

4 A 5 a \$17 00

Satanick 8

80 POINT

4 A 5 a \$12 25

Land 3 Mark

54 POINT

4 A 5 a \$10 25

6 Dead Soldier

48 POINT

4 A 5 a \$7 75

friends 7 Grave

36 POINT

5 A 8 a \$5 50

Cunard & Stuart \$2

24 POINT

8 A 16 a \$4 50

Patriotism 

18 POINT

8 A 25 a \$4 00

Railway 58 Coach

12 Point size in preparation

**Florentine Heavyface**

48 POINT

4 A 5 a \$7 75

**SOUNDING  
Army 9 Packs**

36 POINT

5 A 6 a \$5 50

**PORTSMOUTH  
Cruiser 83 Station**

24 POINT

6 A 10 a \$4 50

**REGULAR SOLDIERS  
Gentlemanly 25 Characters**

18 POINT

10 A 16 a \$4 00

**AMERICAN  
Type 8 Founder**

12 POINT

16 A 20 a \$3 25

**TEXAS RANGERS  
Marching to Quincy 8**

10 POINT

20 A 26 a \$3 00

**HUMBUG OINTMENT  
Efficacious 9 Medicaments**

8 POINT

22 A 30 a \$2 75

**DELIGHTFUL PAGEANTS  
Viewed from a Hundred Stands 24**

6 POINT

24 A 36 a \$2 50

**ENDURE EASTERN HARSHIPS  
Mountain Climbers \$34 were Exhausted**

5 POINT ON 6 POINT

24 A 36 a \$2 50

**BASKING IN WINTERS CHILLY WEATHER  
Enjoying the Lavishly-Stocked Larders £254179**

AMERICAN TYPE FOUNDERS COMPANY

48 POINT

4 A 7 a \$6 00

**DENOTE WISDOM**  
The Path to Success  
is that of Common  
Sense, which is the

36 POINT

6 A 9 a \$5 00

**THRIFT AND ACTIVITY**  
Notwithstanding all that  
has been said of Lucky  
Hits, the best Success in  
Life is not that which is  
superinduced by chance

30 POINT

8 A 12 a \$4 50

**FONDEST HOPES DASHED**

Those who Fail in Life are apt to assume the tone of injured innocence, and conclude that everyone is opposed to them

24 POINT

12 A 18 a \$4 00

**PERSONS PRONE TO COMPLAIN**

It will generally be found that men who complain, and constantly bewail their bad luck, are only reaping the consequences of their own neglect

18 POINT

15 A 25 a \$3 50

**ADVANCEMENT IN THE BUSINESS WORLD**

**S**TRICT Attention, Punctuality, Application, Method, and Dispatch, are the principal qualities for the efficient conduct of any kind of business. It is the result of every-day experience, that steady attention to matters of

48 POINT SCHœFFER OLD STYLE INITIALS 3 A \$4 00

AMERICAN TYPE FOUNDERS COMPANY



15 POINT

18 A 30 a \$3 00

## WORKS OF FAMOUS AUTHORS SUNK IN OBLIVION

**P**ARADOXICAL as it may seem, the chief causes of the oblivion of books is no longer their extinction, but the fond care with which they are preserved, and their rapid multiplication. The printing press of to-day is more than a match for the moth and worm \$270

36 POINT SCHœFFER OLD STYLE INITIALS 4 A \$3 50

12 POINT

20 A 40 a \$2 50

## OLD BOOKS BURIED BY THE ACCUMULATION OF THE NEW

**T**HE destroyer fulfills his commission by burying books under the pyramid which is formed by their accumulation. It is a striking example of the impotence with which man struggles against the destiny which awaits him and his works. The very means he takes to insure immortality destroys it. The activity of the press, by which he seemed to have taken pledges against time and fortune, is that

24 POINT SCHœFFER OLD STYLE INITIALS 6 A \$2 50

10 POINT

25 A 50 a \$2 25

## PERILS OF COLUMBUS ON HIS VOYAGE OF DISCOVERY TO THE WESTWARD

**I**NDICATIONS of approaching land became more certain, and excited hopes in proportion. The birds began to appear in flocks, making towards the southwest. Columbus, in imitation of Portuguese navigators who had been guided in several of their discoveries by motion of birds, altered his course from due west toward that quarter whither they pointed their flight. But, after holding on for several days in this new direction, without any better success than formerly, having seen no object during thirty days but the sea and sky, the hopes of his companions

24 POINT SCHœFFER OLD STYLE INITIALS 6 A \$2 50

8 POINT

25 A 50 a \$2 00

## SAILORS LOSE HEART AND WANT COLUMBUS TO TURN ABOUT AND SAIL FOR EUROPE

**D**ESPAIR, impatience and rage appeared in every countenance. All sense of subordination was lost, and a scene of confusion ensued. The officers who had previously concurred with Columbus in opinion, and supported his authority, took part with the private seamen, and they assembled tumultuously on the deck, expostulated with their commander, mingled threats with their expostulations, and wanted him to tack about and return to Europe, which he was loth to do. Columbus perceived that it would be of no avail to have recourse to any of his former arts, which, having been tried so often, had now lost their effect and that it was impossible to rekindle any zeal for the success of the expedition among men in whose breasts

15 POINT SCHœFFER OLD STYLE INITIALS 6 A \$1 50

AMERICAN TYPE FOUNDERS COMPANY

60 POINT

3 A 5 a \$8 50

Leads the Style  
in Black Letters

48 POINT

3 A 8 a \$6 75

Early printers were  
loud in their praise

36 POINT

4 A 10 a \$5 00

Gothic went out of fashion  
in Europe and France at  
the end of the 16th century

## Bradley Series

24 POINT

5 A 16 a \$3 50

**G**ERMAN printers of 1450 used bold Black Letters so that they could avoid detection in their many undertakings of a hazardous nature

18 POINT

8 A 25 a \$3 25

**T**HE pages of early books were either large or small folios, but sometimes quartos, and were therefore cumbrous and unhandy. Aldus Manuccio, of Venice, was the first to introduce the

12 POINT

15 A 45 a \$3 00

**G**UTENBERG was over sixty years of age when *The Dictes* was printed, and was notable for his industrious habit. He possessed good sound

10 POINT

16 A 50 a \$2 75

**F**AUST and Schœffer printed the Bible, Psalter and other important works. From this rapid summary we may conclude: 1. That the merit of the invention of the art of printing, however rude it may

6 POINT

18 A 52 a \$2 50

Gutenberg continued printing at Strasburg until the year 1444, when, his means being exhausted, he rejoined his uncle at Mentz. Here he renewed his experiments, and, as he needed financial assistance, secured an introduction to John Faust, a money-lender

6 POINT

20 A 60 a \$2 25

The credit of inventing the art which perpetuates the history and achievements of all the arts and sciences has been obstinately contested, several cities having advanced rival claims to the honor of the discovery. This, however, should be no matter of surprise when we consider that the inventor of any new art, unprotected by law, would naturally endeavor to conceal its process for his own use and advantage. After due

54 POINT BRADLEY INITIALS 3 A \$4 25  
42 POINT BRADLEY INITIALS 3 A \$3 00

SINGLE LETTER 25 CENTS  
SINGLE LETTER 20 CENTS

AMERICAN TYPE FOUNDERS COMPANY

## Bradley Outline

80 POINT

3 A 5 a \$8 50

Leads the Style

48 POINT

3 A 8 a \$6 75

Early printers were

36 POINT

4 A 10 a \$5 00

Gothic went out of fashion  
in Europe and France at

24 POINT

5 A 16 a \$3 50

German Printers of 1450 used bold  
Black Letters to avoid being detected

18 POINT

6 A 25 a \$3 25

Pages of early books were either large or small  
folios, but sometimes quartos, and were there-  
fore cumbrous and unhandy ~ Aldus Manuccio

*This series will be completed early in 1898, when specimen sheets will be sent to all who receive this book.  
At the time of going to press it was impossible to quote the prices  
of the two sizes shown on this page*

# Announcement

---

**Two sizes of this magnificent letter are shown in advance of completion of the series. All sizes, from six to sixty point, will be completed early in 1898**

## Bradley Extended

**Will be welcomed by all who use our Bradley. We predict that it will be the most popular style of the year. Classical in its design, it is as legible as Roman, whether used for text or display. The smaller sizes will delight all Typographers.**

**Burritt Text Series**

48 POINT

4 A 8 a \$7 00

**Student Respond**

42 POINT

4 A 10 a \$6 00

**Bookworm Convinced**

36 POINT

5 A 12 a \$5 00

**Securing Ancient Volumes**

30 POINT

5 A 16 a \$4 50

**Highly Valued by Bibliophiles**

24 POINT

6 A 18 a \$3 50

**Books Printed in Bold Black Types  
Display the Work of Early Printers**

18 POINT

8 A 20 a \$3 00

**Valuable Specimen of  
Antiquated Pamphlet**

14 POINT

10 A 24 a \$3 00

**Revised by Competent and  
Trusted Rubian Assistants**

12 POINT

12 A 30 a \$3 00

**Archives of Fancy Typography  
Wonderful Discovery Recorded**

10 POINT

15 A 40 a \$2 50

**Noted Literary and Scientific Researcher  
Awarded Seventy-Three Laurel Wreaths**

1234567890

1234567890

AMERICAN TYPE FOUNDERS COMPANY

Laclede Series

72 POINT

3 A 5 a \$12 00

*Monumental*

60 POINT

3 A 6 a \$10 00

*Broken Dishes*

48 POINT

4 A 7 a \$8 00

*Country Residence*

36 POINT

4 A 9 a \$6 25

*Unique Pictures Framed*

24 POINT

5 A 14 a \$4 00

*Industrious  
Western Farmer*

18 POINT

5 A 16 a \$3 25

*Enchantment  
Handsome Decoration*

12 POINT

7 A 24 a \$3 00

*Financial Speculation  
Renowned European Negotiators  
1 2 3 4 5 6 7 8 9 0*

10 POINT

9 A 30 a \$2 75

*Journalistic Conventions  
Neapolitan Newspapers Represented  
1 2 3 4 5 6 7 8 9 0*

AMERICAN TYPE FOUNDERS COMPANY

# *PORTLAND BANQUET*

*Ended in Gayeties*

*There is considerable pleasant anticipation of the time*

## *HANDSOME TURNOUTS*

*Old Orchard, August 26*

*This picturesque resort, famous for its hospitality, its red berries and its pretty girls, opened its gates to-day.*

## *GRAND COACHING PARADE*

*Greeted with Mighty Cheers*

*The coaching parade exceeded the most sanguine expectancy of its promoters and called forth some of the highest commendations 85*



## Harvard Italic

14 POINT

16 A 26 a \$3 00

### *FIVE HUNDRED THOUSAND PEOPLE*

*Cheered Vociferously for Hours*

*The parade of veterans of the G. A. R. in the city of Buffalo, August 25, 1897, was a grand success. Massachusetts division numbered fully 3000 men*

12 POINT

18 A 30 a \$3 00

### *BROOKLYN FEMALE ACADEMY BURNED*

*Destroyed by Fire New Years Day, 1853*

*Still in the ashes lived the wonted flame, and a new school rose, a stately monument to mark the spot. November 9, 1854, the Packer Collegiate Institute was officially opened*

10 POINT

20 A 34 a \$2 75

### *FASHIONABLE MILLINERY AND DRESS GOODS*

*Latest Styles from London, Paris and Berlin*

*Our several departments are fully stocked with fresh merchandise which is matchless in quality, newness, variety and cheapness. It is now high tide of the Holiday Season, and buyers should not 46*

9 POINT

20 A 34 a \$2 50

### *STAGES BETWEEN XYLOGRAPHY AND TYPOGRAPHY*

*No Question has Aroused Keener Discussion*

*No question has aroused more interest, or excited keener discussion in the history of printing, than that of the use of movable wooden types as a first stage in the passage from Xylography to Typography. 123456*

8 POINT

24 A 38 a \$2 50

### *HARVARD ITALIC SERIES*

*Favorably Impress Artists*

*The beauty of a letter does not necessarily consist in the fancy ornament, but well-proportioned simplicity 86*

6 POINT

32 A 42 a \$2 25

### *DISBAND OUR ORGANIZATION*

*By Order of Social Members*

*To secure time for more profitable employment we dissolve the society which in the past has monopolized our thoughts by day and our dreams while we quietly slumbered 123456*

AMERICAN TYPE FOUNDERS COMPANY

24 POINT

8 A 14 a \$5 00

*Swagger and Gasconade*  
 Inform the public that to-day they  
 start in business confident of success

18 POINT

8 A 20 a \$5 05

*Having Cut our Wisdom Teeth*  
 We are satisfied that we have ability of very  
 high order, and ask you and your friends to  
 examine our goods, prices and correct methods

12 POINT

12 A 32 a \$3 90

*The Earthquake Shook us Nearly out of our Boots*  
 And our goods off the top shelves. The stock is uninjured; but  
 rather than rearrange it we will allow it to go at ninety-nine per  
 cent. discount. Come early and often, and take advantage of the  
 opportunity that offers itself to get one dollar's worth for a penny

1 2 3 4 5 6 7 8 9 0

9 POINT

12 A 32 a \$2 70

*The Almshouse Doors are Wide Open for our Reception*  
 We close our business career this morning with the well-wishes of the sheriff, an  
 immense stock of experience, some tattered clothes, no money, and many creditors;  
 but our Wisdom Teeth are still in good condition, and in the future we shall exercise  
 them on such alimentary substances as may be doled out to us by the authorities

1 2 3 4 5 6 7 8 9 0

*Grand Autumnal Display*  
*The Australian Tailoring Company*  
*will Exhibit several Leading Styles*  
*Wednesday, September 25th, 1894*

*Our Ambition is to Give Satisfaction*  
*For the convenience of buyers who live out of*  
*town we have issued a Descriptive Catalogue,*  
*magnificently embellished with Photogravures,*  
*which we send to any address upon application*

*Dress Goods, Millinery, Laces and Curtains*

*Our several departments are fully stocked with merchandise,*  
*which is matchless in quality, style, variety and cheapness.*  
*Prospective purchasers should find their way to our reliable*  
*establishment, and examine our stock and prices. We have*  
*an excellent corps of salesladies who are always gladsome,*  
*and who deem it a pleasure to display our goods to customers*

**French Script**

54 POINT

3 A 9 a \$12 20

*Meditation  
Lensive Thoughts*

44 POINT

4 A 12 a \$11 25

*Growl & Vixen  
Homestead Destroyers  
Court Litigants*

36 POINT

5 A 14 a \$10 75

*Treatise on Lacking  
Street-cars, Meal Barrels  
Excursion Steamboats*

**French Script**

28 POINT

8 A 18 a \$8 90

*Truant School-boys  
Captured in Bathing Costume  
Unadorned Humanity*

22 POINT

7 A 24 a \$7 25

*Chicken and Watermelon Thieves  
Arrested and Punished  
Without the aid of Constable, Judge, or  
Jury, and Smoke-Houses, Orchards and  
Kitchen-Gardens protected with great care*

18 POINT

8 A 24 a \$6 00

*Grand Exhibition of Animated Curiosities  
Discovered in Queer Places  
Captured by Miss Illaqueate, who will explain  
hourly the Process by which they were Bagged,  
and relate some Amusing Incidents in which the  
Traps of this Company figured very prominently*

AMERICAN TYPE FOUNDERS COMPANY

## French Script

14 POINT

9 A 30 a \$5 00

*Hoodwinking Manufacturing Co.*

*Notice is Given to all Whom it may Concern*

*That M<sup>rs</sup> Legerdemain is Agent*

*For our Traps, which are well adapted to catch Elephants or Heirefess, Mendicants or Millionaires, rabid Dogs or runaway Apprentices. She can clearly explain all their merits, because her late Husband, a man of much wealth, was ensnared by one of them. This Lady will call on you about September 28, 1946, and we ask a fair trial, in Forest or Parlor, of the Apparatus she will present, as we know they will be found very useful in every Family*

*Rented on Shares if Desired*

*Directions for Operating Sent with each Article*

*Repairs Executed Neatly and Promptly*

12 POINT

10 A 35 a \$4 00

*Very Profitable Business Opportunity*

*Agents Wanted to Introduce our Goods Throughout the Globe*

*Everywhere Salable and Everywhere Useful*

*Recent Improvements in Delusive Appliances have brought them so near perfection that fugitive Cashiers and fraudulent Debtors may be caught on the wing, Voters entrapped for Office-Seekers, lost Dogs speedily recovered, Subscribers obtained for uninteresting publications and unpopular schemes, wealthy Simpletons corraled without the use of Stool-Pigeons, Lovers procured for Old Maids, derelict Steamers brought to Port, Recruits rallied around Whingly Aspirants, Monsters or Midgets lured from their native strongholds, or Frogs and Fish from the stream at the back door*

*Apply at Salesroom before 11.29 p. m.*

*Where Samples may be had and Information Received*

*Territory in African Wilds Unoccupied*

AMERICAN TYPE FOUNDERS COMPANY

*Profitable Business*  
*Rushlight Manufacturing Co.*  
*No. 6941 Gimmer St.*

*Stockholders, Attention!*  
*Financial necessities compel the Management*  
*to order an assessment on every share of stock*  
*of the Rushlight Manufacturing Company*

*Guaranteed Dividends, one Hundred per Cent.*

*Formation of a new Company*

*Our facilities for manufacturing Rushlights are excellent,*  
*and, as you are one of our intimate friends, we offer you*  
*the privilege of coming into our corporation on the ground*  
*floor. The par value of our shares is \$96.58, but, if*

36 POINT

3 A 4 A 12 a \$11 90

Artistic Fancy  
Certificate of Behavior

24 POINT

3 A 5 A 20 a \$8 40

Printing with Economy  
Quaintly Harmonizing Letters

18 POINT

3 A 5 A 25 a \$6 30

Adornment of Typography  
Fanciful Conceits Eagerly Welcomed

12 POINT

10 A 50 a \$5 20

Managers of Business Enterprises  
Recognize in the Printing-press and other Appliances  
Helpmates toward Prosperity  
1 2 3 4 5 6 7 8 9 0

*The Initial Capitals are cast on the same body as the lower-case, and do not require justification*



## Circular Script

PATENTED

24 POINT

10 A 50 a \$18 65

Actuated by philanthropic motives, we determine to devote our fortune and the labor of life to the benefit of mankind.

18 POINT

10 A 50 a \$12 20

Rubhard Lively, M. D.

Dear Sir:—I am troubled with Weakness of the Back and an Indisposition to Labor. If you can cure me of this disease you will receive the lasting gratitude of  
Yours truly,  
Gregory Lackthrift.

12 POINT

10 A 50 a \$7 00

Gregory Lackthrift.

Dear Sir:—Having carefully studied all the symptoms of your case, I have forwarded to your address a package of superior Elbow Grease, which, if diligently and perseveringly applied, from 7 a. m. to 6 p. m., daily, will relieve your troubles. To prevent a recurrence of the disease, Industrious Habits must be formed, and exercise of a quickstep character freely indulged in.

Rubhard Lively, M. D.

ALL COMPLETE WITH FIGURES

AMERICAN TYPE FOUNDERS COMPANY

18 POINT

9A 18a \$4'00

## TIMID AND OBSCURE

Every day sends to their graves a number of obscure men, who have only remained such because timidity

12 POINT

12A 28a \$3 50

## THE VAGABOND AND THE ROGUE

Beware of those who are homeless by choice. You have no hold on a human being whose affections are without a tap-root. The laws recognize this truth in the privileges which they confer upon free holders; and public opinion acknowledges it \$239

10 POINT

14A 32a \$3 25

## MAY AMONG NEW ENGLAND HILLS

I love to look on these young faces, and see the firstlings of a young man's beard, and the maidenly bloom blushing over the girl's fair cheek; I love to see the pure eyes beaming with joy and goodness, to see the unconscious joy of such young souls impatient of restraint, and longing for the heaven that we fashion here. So have I seen in early May among New \$1480

8 POINT

20A 44a \$3 00

## TIME IS THE CRADLE OF HOPE

It constantly flies, yet overcomes all things by flight; and although it is the present ally, it will be the future conqueror of Death. Time, the cradle of Hope, but the grave of Ambition, is the stern corrector of Fools, but the salutary counselor of the Wise, bringing all they dread to the one, and all they desire to the other; but, like Cassandra, it warns us with a voice that even the sagest discredit too long, and the silliest believe too late. Wisdom walks before it, Opportunity with it, 9054

## Waverly Circular

12 POINT

Card Font 10A 20a \$3 00  
Circular Font 30A 140a \$14 25

### PECULIARITIES INHERITED

Man is a nomad. In his natural state, before he was hampered by the conventionalities of society, or the demands of trade and commerce, he had wandered aimlessly from hither to yon. Where he pitched his tepee or skin-covered hovel, there was his home. Modern man inherits these instincts.

10 POINT

Card Font 12A 24a \$3 10  
Circular Font 36A 150a \$13 85

### ANCIENTS ORGANIZE EXPEDITIONS

The spirit of penetrating into unknown countries and sailing trackless seas led the Egyptians nearly three thousand years before Christ to build quaint vessels, the prows of which they decorated with handsomely carved images of goddesses, whose smiles they often sought upon their explorations. It led the Norsemen over the Atlantic, and spurred Columbus to success.

8 POINT

Card Font 14A 30a \$3 00  
Circular Font 40A 160a \$10 85

### ENTHUSIASTIC POPULATION DESCRIBED

There is, perhaps, no nation in which the inborn instinct to travel is stronger than in the American. Go where you will, you find the country is webbed with railroads, and the stations and trains filled with an ever-restless throng. Stand upon the wharves and see the ocean steamers leave, their decks crowded with tourists, and the piers with people who secretly stifle the wish that they were going.

1234567890

## Litho

18 POINT

Card Font 6A 16a \$3 15  
Circular Font 31A 112a \$16 75

Whereas, on the 18th day of May, 1897, Thomas Fiddlefaddle was found near the Public Hall, sitting astride a fence, and there remained whittling a pine

√ w° h<sub>o</sub>

*These letters are mortised, not kerned*

m<sub>o</sub> n<sub>o</sub> r

AMERICAN TYPE FOUNDERS COMPANY

## Tristan Italic

30 POINT

4 A 4 A 25 a \$6 00    4 A 25 a \$6 15

*Pinkerton Detectives*

*Carrying Out Very Peculiar Instructions*

24 POINT

5 A 5 A 30 a \$7 50    5 A 30 a \$5 40

*The United States of America*

*The Monroe Doctrine will be Strictly Enforced*

18 POINT

6 A 6 A 40 a \$6 75    6 A 40 a \$5 25

*Mr. & Mrs. William Browning*

*Request Your Company at Their Daughter's Wedding*

*January 17th, 1897*

12 POINT

10 A 50 a \$4 35

*What grand companionships await us as we turn from the noises and turmoil of life and sit down for an evening amongst our books. Kings of thought of every age stand in serried ranks before us waiting to do our bidding. Poets of the elder time, and of these*

10 POINT

10 A 50 a \$3 60

*Reverie is the nurse of melancholy; and it often takes the place of work in what seems to be working hours, broods over the work, unravels the thread of thought, spreads a haze over the inward vision, and loosens the grasp of the apprehensive powers. This, then,*

8 POINT

12 A 60 a \$3 60

*As flowers carry dewdrops trembling on the edge of the petals, and ready to fall at the first waft of wind or brush of bird, so the heart should carry its beaded words of thanksgiving, and, at the first breath of heavenly flavor, let down the shower perfumed with the heart's gratitude. When the heart is thus in harmony with the will of*

AMERICAN TYPE FOUNDERS COMPANY

## Script No 9

28 POINT

8 A 20 a \$7 65

Manual for Defaulters  
Questions on the Practice of Incognito  
Route-Book to Leckulationville  
1234567890

22 POINT

12 A 32 a \$6 70

Clothiers of the Sovereign People  
Snipper Cutemwell, Pantaloon Snugfit and Associates  
Contractors for Habiliments for Dudedom  
1234567890

18 POINT

12 A 32 a \$4 95

Sharp Practice Association of Gotham  
Semi-Occasional Distribution of Valuable Unincumbered Property  
Promises Deferred Maketh the Heart Sick

12 POINT

12 A 32 a \$3 40

Caoutchouc's Patented Extension Apparatus  
Useful in Cases of Emergency. Omnibuses and Bedsteads Enlarged at Pleasure  
Further Particulars given on Application  
Patent-rights for Unlimited Territory Granted to Firstcomers

AMERICAN TYPE FOUNDERS COMPANY

24 POINT with 36 Point Initials

3 A 4 A 20 a \$7 50

*Society to Encourage Industrious Habits*  
*Initiation of Members*

*Knowing that the Human Hand, intelligently  
 educated and skillfully employed, has delivered*

18 POINT with 30 Point Initials

3 A 6 A 30 a \$6 90

*Meeting for Transaction of Business*  
*Expulsion of Members*

*Whereas, on the 15th inst. Peter Fiddlefaddle was found  
 near the Castle of Indolence, sitting astride a fence, and  
 there remained whittling a pine stick for a period of*

12 POINT with 24 Point Initials

4 A 8 A 40 a \$5 60

*Report of Committee on Extension of Usefulness*  
*Recommendations for Future Activity*

*In the prosecution of our labors we find many persons lying under  
 trees expecting fruit to drop into their mouths, others waiting for  
 something to turn up, numbers lingering around hoping to step into  
 other people's shoes, some who appear anxious to shovel snow in*

18 POINT with 36 Point Initials

3 A 4 A 12 a \$8 80

Typographical Appliances  
Accurately Mortised Printing Types  
Recherché Wonders

18 POINT NO 2 with 36 Point Initials

3 A 4 A 20 a \$6 60

Imitative Penmanship Lessons  
Mathematical Reproduction of Signatures  
Progressive Craftsmen

12 POINT with 24 Point Initials

4 A 8 A 32 a \$5 25

Reminiscences of a Worthy and Honored Citizen  
Local Events Sketched from Memory

To my son Tom, I bequeath all right and title to the Good Name which I intend to leave behind me, and any profit or renown which may be derived therefrom shall be for his sole benefit. To my daughter Mary, I give all shares in the Comet-Tail Utilization Company, and to my wife Clementina my interest in the business of furnishing free Toboggan Rides to women and children. The privilege of giving advice to all comers I leave to Timothy Gibblegabble

1 2 3 4 5 6 7 8 9 0

## Chaucer Series

PATENTED

24 POINT

8 A 14 a \$6 10

Jack Tar Proceeds in haste with  
a cargo of Nutmegs to the Port

18 POINT

8 A 20 a \$5 55

Our stock is replete with some of the most  
Artistic and rare specimens of Cabinetware

12 POINT

12 A 32 a \$4 70

10th month 25, 1682.—On land at last, though in a New  
World. Forests all around us. Carried on shore my kit,  
and under a large tree mended shoes for fellow-passenger

## Circular Black

PATENTED

24 POINT

5 A 10 a \$4 00

Fifth National Bank of Cashtown pay  
to Tony Smart Five Hundred Dollars

18 POINT

8 A 14 a \$3 20

Honeybags & Co.  
Five days after sight pay  
to Typograph & Cresus

12 POINT

8 A 20 a \$2 55

Payable: Produce Note  
For value received I promise to  
deliver one month after date, four  
Radishes to Traffick & Company

9 POINT

10 A 26 a \$2 35

To John Pug, of Canine County  
Take notice, that at an election held at the  
Court House, you were elected Dog Catcher  
Holiath Thickset, Constable

6 POINT

12 A 32 a \$2 10

Institution for Boarding Household Pets  
Received, January 6, 1892, from Amelia Seimster, Five  
Cats, Six Parrots, and Four Pigs, which I promise to  
keep, and provide with Food and Drink for Seven Weeks  
Amiable Petsfriend

AMERICAN TYPE FOUNDERS COMPANY



## Manuscript No 1

24 POINT

6A 22a \$7 00

*Boston Excursion Association  
will again visit Lake Champlain with  
a number of select people  
Saturday afternoon, June 30, 1897*

16 POINT

10A 44a \$6 00

*Office of Winchester Grocery Provision Co.  
After November of the present year the above well-known  
firm will remove to their new Harcross street store  
Storage House, 532 Randolph Avenue*

## Manuscript No 2

24 POINT

6A 20a \$7 00

*Scranton Lumber Company  
Has purchased the entire plot  
of land east of Renova*

16 POINT

10A 40a \$6 00

*Boston, September 23, 1896  
Dear Sir: The regular gathering of the Junior  
Knights of Printing will be held at their usual  
place of meeting, November 15, at 7.30*

AMERICAN TYPE FOUNDERS COMPANY

Novelty Script

72 POINT

3 A 4 a \$16 00

*Rich Child*

60 POINT

3 A 5 a \$11 75

*Love's Dream*

48 POINT

3 A 6 a \$9 00

*Famous Battles*

36 POINT

4 A 6 a \$7 25

*Lithographic Printing*

24 POINT

5 A 12 a \$5 25

*Pay to the Order of Thomas Little*

18 POINT

5 A 16 a \$4 00

*"Truth Crushed to Earth Shall Rise Again"*

1 2 3 4 5 6 7 8 9 0

AMERICAN TYPE FOUNDERS COMPANY

## Old Style Script

30 POINT

Card Font 3 A 9 a \$5 00  
Circular Font 6 A 18 a \$9 00

*As the popularity of the old style effects in type designs does not seem to be waning, we know*

24 POINT

Card Font 3 A 10 a \$4 50  
Circular Font 6 A 20 a \$8 00

*Florence can still ring her belly with the solemn hammer sound that used to beat on the hearts of her citizens and strike out the fire there. And where*

18 POINT

Card Font 4 A 12 a \$3 50  
Circular Font 8 A 24 a \$6 00

*Life had its zest for the old Florentine when he, too, trod the marble steps and shared in those dignities. His politics had an area as wide as his trade, which stretched from Syria to Britain, but they had also the new*

12 POINT

Card Font 5 A 16 a \$3 00  
Circular Font 10 A 32 a \$5 00

*Even if, instead of following the dim day-break, our imagination pauses on a certain historical spot and awaits the fuller morning, we may see a world-famed city, which has hardly changed its outline since the days of Columbus, seeming to stand as an almost unviolated symbol, among the flux of human things, to remind us that we still resemble the men of the past more than we differ from them, as now*

AMERICAN TYPE FOUNDERS COMPANY

## Royal Script

30 POINT No 1

Card Font 4 A 10 a \$5 00  
Circular Font 7 A 20 a \$9 00

*Men are always helpful through the  
Intellect and the Affections. Other  
Help I find is a false Appearance.  
If you affect to give me bread and*

30 POINT No 2

Card Font 4 A 12 a \$5 00  
Circular Font 7 A 22 a \$9 00

*Man regards his century or his Half-  
Century as the culmination of Light, as  
A festal-day, to which all other centuries  
Lead only as week-days. He can only*

24 POINT No 1

Card Font 4 A 10 a \$4 50  
Circular Font 8 A 20 a \$7 50

*Reading is well Compared to the Filling  
Of a Granary with grain, and thinking to  
Nothing but Sowing the seed. We should  
Always weigh and consider, not contradict.  
Meditation is active; reverie, idle Thought.*

AMERICAN TYPE FOUNDERS COMPANY

## Royal Script

24 POINT NO 2

Card Font 4 A 12 a \$4 50  
Circular Font 8 A 22 a \$7 50

*Among all the Accomplishments of Life none  
Is so important as Refinement; Unlike beauty,  
Nature is not its Parent. By Cultivation and  
Everlasting practice Only can it be acquired in a*

18 POINT

Card Font 4 A 12 a \$3 50  
Circular Font 8 A 24 a \$5 00

*Now comes Winter, Just as savage as when he met the  
Ambitious pilgrims at Plymouth, Indian all over, a  
Naked, Splintery Hemlock for his staff, his Robe off  
Backs of Wild Beasts, Fringed with Icicles, turning  
Into Ringing iron the Ground he treads, and Like a*

12 POINT

Card Font 5 A 16 a \$3 00  
Circular Font 10 A 32 a \$5 00

*By Christianity a Moral motive-power is Supplied, which is Far better  
than any fact or Enactment in Keeping society together; And that is, the  
charity that is not easily Provoked, the love that works no Ill to any of his  
neighbors. To the motives which tend to Insure well-being in this World,  
it adds loftier Hopes, the nobler Aspirations, the better Purposes, that blind  
the Christian man to an endless future. It helps him to be a better Citizen*

10 POINT

10 A 32 a \$4 50

*Beloved, the Earth is to-day so beautiful! that, indeed, makes Man more Tender;  
the Heavens rest with a Caress and Kiss of Love on the earth as a Father on a  
Mother and her children. The flowers and beating Hearts fall into the embrace and  
nestle around the Mother. The twig gently Rocks its Slinger Up and Down, the  
flower cradles its bee, the Leaf its fly and its drop of Honey; in the open flower-cups  
hang the warm Tears, into which the Clouds dissolve themselves, as if in Eyes, my  
flower-beds bear the Rainbow, which is built upon them, Without sinking. Every*

AMERICAN TYPE FOUNDERS COMPANY

**Boston Script**

PATENTED

3 A. 8 & \$15 00

60 POINT

*Eighth Annual Race  
Friday, March 8th*

48 POINT

4 A. 10 & \$12 00

*Pay to Bearer Five Months  
after date 25.75 dollars*

AMERICAN TYPE FOUNDERS COMPANY

36 POINT

5 A 15 a \$10 00

*United States Banks  
Received Seventy Million  
Dollars August 29th*

24 POINT

Card Font 3 A 8 a \$3 00  
Circular Font 7 A 20 a \$8 00

*Leather Dealers Protective Association  
meeting will be held on  
Saturday, November 27th instant*

18 POINT

Card Font 3 A 10 a \$2 00  
Circular Font 9 A 25 a \$6 00

*You are requested to attend the Seventh Annual Dance  
to be given under our auspices in  
Pythian Hall, on Seventeenth Street  
Wednesday evening the 25th of December, 1895*

*A M N O*

*These extra Capitals are put up separately at the following prices: 48 Point, \$1.00; 36 Point, 75 cents;  
24 Point, 75 cents; 18 Point, 50 cents*

# Steelplate Script

PATENTED

30 POINT NO 1

Card Font 4A 10a \$5 00  
Circular Font 7A 20a \$9 00

*The Excellence of Religion is Shown  
By the Fact that Many Pretended  
To possess it. The Odorous Balsam is  
Easily imitated, because it is so precious  
And Fragrant, and Necessarily there  
Are many Spurious kinds; But no one*

30 POINT NO 2

Card Font 4A 12a \$5 00  
Circular Font 7A 25a \$9 00

*The Poor man is Hungry and Athirst: but  
Even for him there is always Food and Drink;  
He is often Heavy-Laden and Weary: but  
For him also Heaven sends Sleep, and this of  
The Deepest; In his Smoky Cribs, a Clear  
Dewy heaven of Rest envelops him and many*

AMERICAN TYPE FOUNDERS COMPANY



# Steelplate Script

PATENTED

24 POINT No 1

Card Font 4 A 12 a \$4 00  
Circular Font 8 A 22 a \$7 00

*Let Honesty be the Breath of thy Soul, and  
Never Forget to have a Penny or Two, when  
All thy Expenses are Enumerated and paid;  
Then Shalt Thou safely reach the Point of  
Happiness, and Independence Shall be thy*

24 POINT No 2

Card Font 4 A 14 a \$4 00  
Circular Font 8 A 28 a \$7 00

*True Life can never be well Developed among Throngs  
And Noises. We must Betake Ourselves into the  
Remote desert Places. In a word, we must get away  
From Men and View Life from such Distance as  
May be Realized by Intimate Divine Fellowmen*

12 POINT

Card Font 5 A 16 a \$3 00  
Circular Font 10 A 32 a \$5 00

*Ambition, that High and Glorious Passion, which makes such  
Haruc among the Sins of Men, Arises from a Proud Desire of  
Honor and Distinction, and when all those Splendid Trappings  
In which it is usually Caparisoned, are Removed, will be found  
To Consist of Mean Materials of Envy, Pride and Covetousness.  
It is Described by the Different Authors as a Gallant Madness, a  
Pleasant Poison, a Hidden Plague, a Secret Poison, the Mith of*

1 2 3 4 5 6 7 8 9 0 .

AMERICAN TYPE FOUNDERS COMPANY

**Spencerian Script**

PATENTED

Card Font 5 A 25 a \$20 00  
Circular Font 10 A 50 a \$40 00

40 POINT

*Coaching Club, Annual Drive,*

*Philadelphia to Somewhere*

*Knobblowing at Sunrise, October 4, 1879*

*Dinner at Crackerhip Mansion.*

*Miss M<sup>r</sup> D<sup>r</sup> Co<sup>r</sup> the & Co. J<sup>r</sup> G<sup>r</sup> W<sup>r</sup>*

AMERICAN TYPE FOUNDERS COMPANY

*Mrs Gushington & Daughter*  
*Fashionable Cicerones*

*Tender the advantages of their company during summer vacations to any family whose rural antecedents were incompatible with the acquirement of an elegant urban polish. Address, -Squash Row*

*1 2 3 4 5 6 7 8 9 0*

*Mrs M<sup>r</sup> D<sup>r</sup> C<sup>r</sup> & Co. Th H Wh*

*Professor Goldpen*

*Ladies' Amanuensis and Correspondent*  
*Orange Blossom Terrace*  
*Scribbleville.*

# Spencerian Script

PATENTED

22 POINT

Card Font 9 A 50 a \$13 65  
Circular Font 18 A 100 a \$27 25

*This Series of a New Style of Script, which we call Spencerian, we present to the attention of Printers, in the assured confidence that it will meet with their hearty approval. Its elegant appearance is not its only sufficient recommendation; for, in addition to its beauty, it possesses excellent wearing qualities*

*Mrs Mr D<sup>r</sup> C<sup>r</sup> th U<sup>c</sup> Th Tl Wh*

1 2 3 4 5 6 7 8 9 0

18 POINT

Card Font 9 A 50 a \$9 15  
Circular Font 18 A 100 a \$18 30

*This Intelligent Combination of late Improvements is presented for further appreciative consideration. Its tones are of a magnificent singing quality, of marvelous volume and strong penetrating power, and in perfect sympathy with the human voice, while the wave-like melodies of its softer modulations enchant all by their purity, increasing the delights of home and enhancing the enjoyments of social gatherings*

*Mrs Mr D<sup>r</sup> C<sup>r</sup> th U<sup>c</sup> Th Tl Wh*

\$ 1 2 3 4 5 6 7 8 9 0 £

AMERICAN TYPE FOUNDERS COMPANY

**Spencerian Script**

PATENTED

60 POINT

3 A 9 a \$17 80

*Highway Department*

*United States Coast Surveyors*

*Topographical Gathering.*

AMERICAN TYPE FOUNDERS COMPANY

**Spencerian Script No 2**

PATENTED

Card Font 2 A 5 A 25 a \$20 75  
Circular Font 4 A 10 A 50 a \$41 50

40 POINT

*Academy of Natural Sciences  
Meeting for Promotion of Zoological Researches  
Microscopic Investigation*

*Wednesday Evening, February 7, 1895*



*The Ornamented Capitals are suited to work with the lower-case of both series of Spencerian Script*

26 POINT

Card Font 3 A 6 A 30 a \$16 05  
Circular Font 6 A 16 A 60 a \$32 05

*Distribution of Unexpended Greenbacks*  
*Midnight Perambulators*

*This Petition of male inhabitants of the township of Loaferdom, in the County*

22 POINT

Card Font 3 A 9 A 50 a \$14 05  
Circular Font 6 A 16 A 100 a \$28 05

*Lessons in the Arts and Mysteries of Courtship*  
*Methods for Becoming Fascinating*

*The commodious Steamer Orange Blossom, expressly built for our Nymeneal trade, will make its first*

16 POINT

Card Font 3 A 9 A 50 a \$10 35  
Circular Font 6 A 16 A 100 a \$20 65

*Initiation of Members and Cabalistic Observances*  
*Every Wednesday and Friday Evening*

*The Examiners and Faculty of the University of Teachemfast, in the City of Classic Lore, do hereby Certify that*

1 2 3 4 5 6 7 8 9 0

*L M N O P Q R S T*

*The Ornamented Capitals are suited to work with the lower-case of both series of Spencerian Script*

## Vertical Writing

24 POINT

7 A 22 a \$8 00

24-point Vertical Writing  
manufactured by  
American Type Founders  
Company

18 POINT

8 A 25 a \$4 75

Lessons in the Arts of Courtship  
Methods of Fascination  
The commodious Steamer Blossom  
expressly built for Hymeneal trade  
will make its first Grand Trial Trip  
on the twelfth day of January, 1983

12 POINT

10 A 35 a \$4 00

Blatherskite Improvement Association  
November 24, 1897  
The subject for discussion will be  
Has the Eloquence of Orators or the Active Worker  
done most for mankind

AMERICAN TYPE FOUNDERS COMPANY



# Copperplate Roman

ABCDEFGHIJKLMNOPQRSTUVWXYZ&  
ABCDEFGHIJKLMNOPQRSTUVWXYZ  
12345 6789 0

NOTE THE  
ENGRAVED  
EFFECT

DR HAROLD M. WILLIAMSON  
Nº 46 RITTENHOUSE SQUARE

6 POINT  
30 A 60 A \$3 00

PROF. ROBERT A. HARRISON  
TEACHER OF LANGUAGES

MR AND MRS FRANK ALLISON  
AT HOME  
WEDNESDAY AFTERNOON  
Nº 518 NORWICH ST

*OTHER SIZES IN PREPARATION:—A smaller size on 6 Point body, and 8 and 10 Point sizes of Copperplate Roman will be ready early in 1898*

AMERICAN TYPE FOUNDERS COMPANY

## Standard Typewriter

12 POINT

20 A 100 a \$7 45

Through the courtesy of the manufacturers of the Remington Standard Type-Writer, ~~we~~ we are permitted to present in type (from facsimile impressions furnished by them) ~~and~~ an exact counterpart of the type-writing of their No. 2 machine.

As the above Type-Writer has the approval of business people in general, and as the number in use far exceeds ~~the~~ those of any other make, the printing craft will doubtless avail itself of the style of type ~~the~~ herewith presented as being the latest and

## Smith-Premier Typewriter

12 POINT

20 A 108 a \$7 50 108 a \$4 10

The vastness of the universe must render foolish the supposition that this planet is the only inhabited one; and the unity of laws and of substances asks us to imagine the beings upon other spheres to be moving to and fro in the likeness of man, speaking a language and busied by the useful and the beautiful. We may even assume that such is the oneness of intelligent life that if the inhabitants of these different planets were to meet in some general home in immortality, they would prove to be of the one race.

AMERICAN TYPE FOUNDERS COMPANY

## **Yost Typewriter**

12 POINT

20 A 90 a \$6 50 90 a \$4 65

We beg to call your attention to this exact imitation of Yost Typewriter Type which was made especially for "imitation" work. No expense has been spared to make this type the most perfect imitation ever placed on the market, and all engaged in doing this class of work should send their orders at once if they wish to be up to date. The font consists of eighty-four characters, is complete with crossed-out letters as well as all character on the Yost machine

## **Stenograf**

12 POINT

20 A 60 a \$4 65

Since the printing of the call for the regular meeting, a petition has been received from the unemployed members of our Union asking that some action be taken at the next meeting for their temporary relief. This is an important matter and calls for the careful consideration of the membership, and a full attendance on Saturday evening, December 26, at five o'clock, at 16 Commerce avenue, is earnestly requested.

**AMERICAN TYPE FOUNDERS COMPANY**

## Law Italic No 42

28 POINT

7 A 14 a \$4 50

**COURTSHIP PRACTICE**  
*Farewell Kisses Quickly Given*

22 POINT

8 A 20 a \$3 60

**FEARFUL**  
*Natives Protected*

12 POINT

14 A 42 a \$3 00

**GENERAL NOTICE**  
*This is to Certify that John Uxorene and Penelope Sweet*

8 POINT

25 A 70 a \$2 85

**INDENTURE TO LEARN HIGH LIFE**  
*This Indenture witnesseth: That Caroline McFlippen, daughter of Timothy and Mary Ann McFlippen, hath bound herself to the*

18 POINT

10 A 28 a \$3 30

**PROCLAMATION**  
*Notice is hereby given*

10 POINT

20 A 52 a \$2 80

**MASTER MACHINIST**  
*You are hereby commanded to take the body of Ephraim Easy, if he be*

8 POINT

25 A 70 a \$2 45

**SUMMONS AGAINST A CONSTABLE**  
*Whereas, Jonathan Shearplow, one of our Justices of the Peace in and for the County of Common Complaint, lately, that is to say, on the third day of October, A. D. 1795, issued an execution*

## Law Italic No 40

12 POINT

12 A 32 a \$3 15

**NOTIFICATION**  
*The Female Voters of the 51st Ward are not*

8 POINT

25 A 70 a \$3 95

**GABTOWN MEETING**  
*Will be holden in the town of Tattling, on Wash-day, June 30, 1927, at tea-time, for the*

10 POINT

20 A 52 a \$4 05

**SIXTH DISTRICT**  
*Peter Lambsoul, the 13th husband of Mrs. Spitfire*

6 POINT

25 A 70 a \$3 40

**SATISFACTION DEMANDED**  
*Your apprentice, John Lazy Fellow, has this day, November 24th, 1976, called at my office in Knockemdown Township in the said county, and is*

AMERICAN TYPE FOUNDERS COMPANY

## Crayon Series

36 POINT

3 A 5 a \$6 30

Atlantic & Pacific

24 POINT

5 A 10 a \$5 15

Resolutions & Amendments

18 POINT

5 A 12 a \$4 05

Beechtown Forestry Association  
1 2 3 4 5 6 7 8 9 0

---

## Half-tone Series

36 POINT

4 A 8 a \$6 30

DECISION 47 Crimson

24 POINT

6 A 12 a \$4 50

BRIGHTER MOUNTAIN  
Boston Mechanic Brighter 35

18 POINT

8 A 16 a \$3 95

SUBURBAN PREDICTIONS  
Guarding Public 35 Private Documents

---

AMERICAN TYPE FOUNDERS COMPANY

Luray Series

PATENTED

36 POINT

3 A \$5 40

PUNCHERS

30 POINT

4 A \$4 30

SIXTH GAME

24 POINT

5 A \$3 35

SPRING SUNSET

18 POINT

6 A \$2 70

HOMES FOR MINERS  
1 2 3 4 5 6 7 8

Shadow Series

PATENTED

36 POINT

3 A \$4 60

EXECUTORS

24 POINT

7 A \$4 00

TICKET PUNCHING

18 POINT

10 A \$3 40

RENDERED  
1 2 3 4 5

12 POINT

16 A \$2 75

SEASON TICKET  
1 2 3 4 5 6 7

AMERICAN TYPE FOUNDERS COMPANY

**Steelplate Gothic**

PATENTED

38 POINT

4 A \$4 10

**RENOUNCEMENT**

24 POINT

7 A \$3 00

**MORNING AMUSEMENT**

18 POINT

8 A \$2 45

**EMINENT AMERICAN DOCTOR**

12 POINT

12 A \$2 15

**PERFECTLY RELIABLE INFORMATION**  
**1 2 3 4 5 6 7 8 9 0**

**Tinted Series**

PATENTED

38 POINT

4 A \$4 60

**WATERWORKS**

30 POINT

5 A \$3 85

**MAIDEN**

24 POINT

7 A \$3 30

**RAMBLES**

18 POINT

8 A \$2 65

**ORCHESTRA**  
**1 2 3 4 5 6**

12 POINT

12 A \$2 15

**ORGAN BUILDERS**  
**1 2 3 4 5 6 7 8**

AMERICAN TYPE FOUNDERS COMPANY

## Stipple Series

PATENTED

48 POINT

6 A \$6 90

PROVIDENCE

36 POINT

7 A \$5 35

MIMIC FIGHTING  
1234567890

## Fillet Series

PATENTED

36 POINT

4 A \$4 85

STREAMER

24 POINT

7 A \$3 85

FRENCH WINES

18 POINT

9 A \$3 25

CELERY AND CLARET  
1234567890

*Space and End Ornaments furnished with fonts*

AMERICAN TYPE FOUNDERS COMPANY



**Medallic Series**

PATENTED

36 POINT

4 A 8a \$4 60

**Banking Company of Honestville**

24 POINT

6 A 14a \$3 95

**Industry Grappling with Interesting Problems**

18 POINT

7 A 16a \$3 00

**Apprentices Determined to become Competent Journeymen**  
**1234567890**

**Stencil Series**

PATENTED

36 POINT

4 A 6a \$7 90

**MUSEUMS**  
**Center Figures**

24 POINT

8 A 8a \$5 20

**ENGAGEMENT**  
**Giving Music Lessons**

18 POINT

7 A 10a \$4 20

**RAISING**  
**Hardy Roses**  
**12345**

12 POINT

10 A 16a \$3 30

**MOONLIGHT**  
**Coasting Expenses**  
**12345678**

AMERICAN TYPE FOUNDERS COMPANY

36 POINT

4 A 8 a \$7 40

# MENDING Sewing Machine

24 POINT

5 A 7 a \$5 10

# HONORABLE Economy and Honesty

18 POINT

7 A 10 a \$4 00

# EXPERIMENTAL Floating and Flying Machine

12 POINT

10 A 14 a \$3 55

# SECRET CUSTODIANS Guarding Public and Private Documents

10 POINT

12 A 18 a \$3 00

# PROGRESSIVE BUSINESS Commission Brokers Securing Government Silver

8 POINT

14 A 18 a \$2 90

**PREVARICATING**  
Showmen and Sailor Yarns  
1 2 3 4 5 6 7 8 9 0

6 POINT

18 A 20 a \$2 50

**LEGAL RESTRAINT**  
Thermometers far from Stationary  
1 2 3 4 5 6 7 8 9 0

**Broadgauge Shaded**

40 POINT

5 A \$11 30

**SOUND**

36 POINT

5 A \$8 90

**HORSES**

28 POINT

5 A \$6 25

**BOUNDED**

22 POINT

7 A \$5 10

**BUNK**

18 POINT

10 A \$5 50

**MENDS**

12 POINT

14 A \$4 20

**DESCRIBE**

10 POINT

18 A \$4 10

**CONQUERED**

8 POINT

22 A \$4 00

**REQUIREMENT**  
12345678

8 POINT

25 A \$3 75

**ELOQUENT VOICES**  
1234567890

**Broadgauge Ornate**

36 POINT

5 A \$7 80

**DRINKER**

28 POINT

5 A \$5 65

**TIME**

22 POINT

7 A \$4 80

**SENSE**

18 POINT

10 A \$4 80

**SCORES**  
1234

12 POINT

14 A \$3 80

**INCLUDING**  
123456

54 POINT

3 A 5 a \$7 80

Carved Stones

42 POINT

3 A 9 a \$5 10

Renaissance Ornaments

30 POINT

4 A 12 a \$3 80

Merrily Consuming Frumenty

18 POINT

8 A 18 a \$2 75

Rejoicing at the Harvest: Home  
Gathering the Productions of Dame Nature

12 POINT

10 A 30 a \$2 35

Ploughing, Broadcast Sowing, Planting  
Open Warfare with the Destructive Enemies of Agriculture

9 POINT

10 A 30 a \$2 15

Lectures on Problems of Human Sustenance  
Superbly Illustrated by Rural Scenes in all Parts of the Globe

8 POINT

12 A 40 a \$2 15

Mankind Influenced by Climate  
Savage and Civilized  
Voraging Propensities of Humanity  
Gormandizing Capacity  
1234567890

8 POINT

14 A 45 a \$1 75

Just issued by Typograph and Company  
Eighteen Quarto Volumes  
Particular Description of the Gipedal Family  
With Illustrations by Chalkitoff  
1234567890

**Priory Text No 2**

36 POINT

5 A 8 a \$6 00

**North American Creeks**

30 POINT

6 A 10 a \$5 00

**Philatelic Speakers Hardship**

18 POINT

6 A 20 a \$4 00

**Eastern Market  
Vermont Producers**

12 POINT

8 A 24 a \$3 19

**International Difficulty  
Harmony Through Friends  
Sealing Question**

**Priory Text No 1**

14 POINT

6 A 24 a \$3 64

**Charter and Provision English Steamers  
Coasting from San Francisco to Discovery Harbor  
Duties Imposed on American Citizens**

12 POINT

12 A 32 a \$3 08

**Grandest Winter Meetings of Boreal Endeavorers  
Installation of the Cyclone, Simoon, Lightning and Open Season  
Nobel Schemes for Directing their Pathway**

10 POINT

16 A 40 a \$3 42

**Bellamy Looking Backward**  
It was a pleasing and not an unprofitable task for Mr. Franklin Bellamy. His imagination carried him ahead of his time, and he saw mankind enjoying the fruits of combined and grand effort

6 POINT

16 A 44 a \$3 00

**Facilities Intelligently Applied**  
Printers who look backward, while they may draw on their imaginations for profits, do not enjoy so encouraging a vision as did Bellamy. We saw improved facilities intelligently applied; achievements in art, literature and industry which were a credit to those engaged

Tudor Black Series

72 POINT

3 A 5 a \$12 00

May View

48 POINT

5 A 8 a \$8 50

Coupon Lover

40 POINT

4 A 12 a \$6 00

Twelve Brigades

36 POINT

4 A 12 a \$5 50

Rockland

24 POINT

5 A 15 a \$4 75

Declination

20 POINT

5 A 15 a \$3 50

Daily Bulletin

18 POINT

8 A 25 a \$3 40

Standard Edition

12 POINT

9 A 30 a \$2 75

Stylish Exterior  
Modern Fashion Model

10 POINT

12 A 38 a \$2 75

House Furnishers  
Stove and Range Dealers

8 POINT

15 A 50 a \$2 75

Wonderful Achievement  
Building Railroad Through China  
1234567890

6 POINT

15 A 50 a \$2 25

Magnificent and Extraordinary  
Exhibition of Fireworks on the Ocean Front  
1234567890

AMERICAN TYPE FOUNDERS COMPANY

Yonkers Series

48 POINT

3 A 8 a \$8 95

# Oriental Stream

38 POINT

4 A 8 a \$4 50

# Gallant Tribe Leaders

30 POINT

5 A 10 a \$3 85

# Southern Chivalry Truly Proverbial Beauty

22 POINT

8 A 15 a \$3 45

# Local Taxes Helpless Victim

14 POINT

10 A 20 a \$2 30

# Combined Efforts General Task System

12 POINT

15 A 25 a \$2 30

# Reactionary Movement Partisan Doctrines Exploded

10 POINT

20 A 30 a \$2 25

# Prosperous Legislators Pandemonium Reigns Supreme

8 POINT

25 A 40 a \$2 10

# Society for the Suppression of Independent Thought among Bachelors

8 POINT

30 A 50 a \$2 15

# Professional Philanthropic Reformers Inconsistent Preachers and Impractical Teachers

1234567890

1234567890

**Title Black Series**

38 POINT

3A 8a \$6 10

**Free Lance  
Unfettered Press**

24 POINT

4A 8a \$4 45

**Public Speakers  
Time-Honored Customs**

18 POINT

5A 10a \$3 40

**Moonlight Association  
Uncertainty of Forked Lightning**

12 POINT

7A 16a \$3 00

**Full Game Bags  
National Coon Hunt  
Great Victory**

10 POINT

8A 20a \$2 85

**Temperate Customs  
Guarantees of Longevity  
Fourscore Years**

8 POINT

8A 20a \$2 70

**Hills and Valleys  
Mountain Summer Jaunts  
Dining in the Woods  
1 2 3 4 5 6 7 8 9 0**

6 POINT

10A 28a \$2 50

**Microscopic Revelations  
Voyages Through a Drop of Water  
Customs of the Inhabitants  
1 2 3 4 5 6 7 8 9 0**

AMERICAN TYPE FOUNDERS COMPANY



36 POINT

3 A 4 a \$4 50

Finest Edition  
Latest Modern Book

26 POINT

4 A 6 a \$4 00

Stock Exchange  
Discounted Bank Checks

22 POINT

4 A 10 a \$3 50

Internal Revenues  
Roast Turkey and Mince Pies  
Served Daily

16 POINT

5 A 14 a \$3 00

Thirtieth Annual Meeting  
New Mexico Board of Public Directors  
Accounts Audited

12 POINT

5 A 18 a \$2 75

Subjects Promptly Furnished  
Discussions on Printed Business Catalogues  
1234567890

## Hamburg Series

28 POINT

5 A 12 a \$4 45

Night Blooming Rosebud

24 POINT

5 A 20 a \$4 35

Achieved Success  
Persistent Washingtonians

22 POINT

8 A 20 a \$3 50

Exquisitely Flavored  
Fancy Mecklenburg Horseradish

18 POINT

10 A 20 a \$3 70

Eschewed Absurd Notions  
Medieval Connoisseurs Excellent Taste

14 POINT

15 A 25 a \$3 30

Often Take Place in Nature  
Periodic Transitions from Mountain to Valley

12 POINT

15 A 30 a \$2 85

International Favorites  
Become Established Faces

10 POINT

15 A 30 a \$2 50

Developments Outstride  
Time in the Art Preservative

8 POINT

20 A 40 a \$2 45

Fashions in Printing Types  
Multiply Each Succeeding Season  
1234567890

6 POINT

30 A 50 a \$2 35

American Enterprise Produces Every  
Imaginable Device for the Saving of Labor  
1234567890

AMERICAN TYPE FOUNDERS COMPANY

## Modern Text No 40

60 POINT

3 A 5 a \$10 35

# Graphic Sketch

46 POINT

5 A 10 a \$12 60

## New Tin

36 POINT

6 A 14 a \$9 65

## Young Boy

28 POINT

6 A 14 a \$6 45

## Shining Morn

22 POINT

8 A 20 a \$5 20

## Cheering the Winner

16 POINT

10 A 28 a \$4 60

## Wonderful Predestinators

12 POINT

12 A 32 a \$4 15

## Magnificent Land Enterprise

## Augustan Text

24 POINT

6 A 14 a \$5 17

## Newspaper Publishing Companies

16 POINT

6 A 16 a \$4 49

## Europeans Manufacture Christmas Specialties

12 POINT

6 A 24 a \$3 34

## Dramatic Corporation Grandest Theatrical Product

10 POINT

10 A 40 a \$3 02

## Mountain Climber Descending Experienced Guide Smoking Cigarettes

8 POINT

20 A 40 a \$3 06

## Another German Warbling Society Elegant Concerts and Laughable Masquerades 1 2 3 4 5 6 7 8 9 0

6 POINT

20 A 70 a \$2 93

## Responsible Astronomers Cause Excitement Telegraph Operators Refusing Corporation Dividends 1 2 3 4 5 6 7 8 9 0

AMERICAN TYPE FOUNDERS COMPANY

# DESIROUS

Honest dealing  
is one secret of  
making friends  
in all vocations

# EXPERIENCE

Constant endeavor  
to furnish none but  
the very best of all  
classes of material  
aids in securing an  
increase of patrons

*Fonts do not contain spaces and quads*

## Poster Antique No 45

---

24 POINT

25 LB. FONT \$12 50

### ENLIGHTENING

Invention has set the pace for improvement in the art of printing so fast that we are continually improving

18 POINT

25 LB. FONT \$13 00

### DILIGENT RESEARCH

Meritorious strides of mechanical genius in the past foreshadowed a larger degree of proficiency in the future development of handicraft. Nowhere has advances been more noted than in the making of type

12 POINT

25 LB. FONT \$13 50

### PECULIAR ANCIENT CUSTOMS

The pages of all early books were either large or small folios, and were therefore cumbersome and unhandy. Aldus Manuccio, a Venitian, was the first to introduce the octavo form. All the leaves were without any running titles, direction words, page numbers, or divisions into paragraphs. The words were printed so close to one another that the matter was not easily read. No punctuation marks were used, except the colon and full point

*Fonts do not contain spaces and quads*

---

AMERICAN TYPE FOUNDERS COMPANY

Poster De Vinne

30 POINT

25 LB. FONT \$12 50

**PROOF PRESS**

**The roller ways on our  
Proof Press are made  
the right height and**  
**12345            67890**

24 POINT

25 LB. FONT \$12 50

**ANNUAL FAIR**

**The Directors take pleasure  
in stating that their Second  
Annual Fair for St. Francis**  
**12345            67890**

18 POINT

25 LB. FONT \$13 00

**GRAND CLEARING SALE**

**Several lots of Madras Shirt Waists  
are to be closed out at about half of  
their regular price. These goods are**  
**12345            67890**

*Fonts do not contain spaces and quads*

AMERICAN TYPE FOUNDERS COMPANY

## Poster De Vinne

14 POINT

25 LB. FONT \$13 00

### PUBLIC AUCTION TO=DAY

Of the Stock of Fine Dry Goods and Notions,  
Boots and Shoes, of the firm of Ketchum &  
Cheatum, will take place at their old stand  
on Broadway, Saturday, March 30th, at Ten  
1 2 3 4 5                      6 7 8 9 0

12 POINT

25 LB. FONT \$13 50

### SPECIAL NOTICE TO SUBURBANITES

Commencing on Monday, the 24th inst., trains for  
Sitka and Yeddo will leave the depot at 9:30 A. M.  
and 3:15 P. M. Passengers on the morning trains  
have privilege of stopping off at Sitka until arrival  
1 2 3 4 5                      6 7 8 9 0

10 POINT

25 LB. FONT \$16 25

### PUBLIC SPEAKING IN THE COURT HOUSE

Hon. E. Pluribus Unum will address his fellow-citizens on the pol-  
itical issues of the day at the Court House in this city at 7:23 p. m.  
to-morrow. Everybody invited. Frauds exposed and a powerful  
searchlight turned on the dark ways of the opposition party. The  
1 2 3 4 5                      6 7 8 9 0

6 POINT

25 LB. FONT \$20 00

### EXTENSIVE SALE OF WATCHES AND JEWELRY

The undersigned finds it necessary to reduce his large and varied stock of  
Watches, Clocks, Jewelry, Gold and Silver Plated Ware, Fine Cutlery, Sta-  
tionery, Fancy Goods, Etc., and will offer any article in his store at 25 per  
cent. off the regular price for 30 days. This offer includes Diamonds, and in  
the stock may be found some of the finest in the market. Watches of  
1 2 3 4 5                      6 7 8 9 0

*Fonts do not contain spaces and quads*

AMERICAN TYPE FOUNDERS COMPANY

## Poster De Vinne Condensed

30 POINT

25 LB. FONT \$12 50

### UP=TO=DATE PRESS

The engraving on opposite page represents their Two-Revolution Press of their

$\frac{1}{3}$   $\frac{2}{3}$   $\frac{1}{4}$   $\frac{1}{2}$  1234567890  $\frac{1}{8}$   $\frac{3}{8}$   $\frac{5}{8}$   $\frac{7}{8}$

24 POINT

25 LB. FONT \$12 50

### FIVE THROUGH TRAINS

Will leave St. Louis on arrival of trains from the East, for points in the West and North. Dining

$\frac{1}{3}$   $\frac{2}{3}$   $\frac{1}{4}$   $\frac{1}{2}$  1234567890  $\frac{1}{8}$   $\frac{3}{8}$   $\frac{5}{8}$   $\frac{7}{8}$

18 POINT

25 LB. FONT \$13 00

### HARVEST EXCURSIONS

The Fast Flying Railway Company will sell excursion tickets over their lines, good for thirty days, for one and one-third fare for

$\frac{1}{3}$   $\frac{2}{3}$   $\frac{1}{4}$   $\frac{1}{2}$  1234567890  $\frac{1}{8}$   $\frac{3}{8}$   $\frac{5}{8}$   $\frac{7}{8}$

*Fonts do not contain spaces and quads*

AMERICAN TYPE FOUNDERS COMPANY



## Poster De Vinne Condensed

14 POINT

25 LB. FONT \$13 00

### DISSOLUTION OF CO-PARTNERSHIP

The firm of Bluster & Wind, composed of B. Bluster and H. Wind, is this day dissolved by mutual consent, H. Wind retiring. M. B. Bluster will continue the business, collect all bills, and attend to the other

$\frac{1}{3}$   $\frac{2}{3}$   $\frac{1}{4}$   $\frac{1}{2}$       1 2 3 4 5 6 7 8 9 0       $\frac{1}{8}$   $\frac{3}{8}$   $\frac{5}{8}$   $\frac{7}{8}$

12 POINT

25 LB. FONT \$16 50

### RELIABLE BUILDING LOTS AT AUCTION

On Wednesday, 23d inst., those twelve choice building lots on Singapore avenue, between Queensland and Edinburgh streets, will be sold at public auction. Each lot has a frontage of 25 feet by a depth of 175.6 to a 20-foot alley. Street improvements

$\frac{1}{3}$   $\frac{2}{3}$   $\frac{1}{4}$   $\frac{1}{2}$       1 2 3 4 5 6 7 8 9 0       $\frac{1}{8}$   $\frac{3}{8}$   $\frac{5}{8}$   $\frac{7}{8}$

10 POINT

25 LB. FONT \$16 25

### MASS MEETING OF PROPERTY OWNERS AT KICKERS' HALL

A meeting of the freeholders of Terredelfuega County will be held at Kickers' Hall on Saturday evening, June 10, at 7 o'clock, to protest against the action of the Delegation selected for the purpose of settling the dispute about the Public Improvements of the Township's Public Roads, Highways and Bridges, that will

$\frac{1}{3}$   $\frac{2}{3}$   $\frac{1}{4}$   $\frac{1}{2}$       1 2 3 4 5 6 7 8 9 0       $\frac{1}{8}$   $\frac{3}{8}$   $\frac{5}{8}$   $\frac{7}{8}$

8 POINT

25 LB. FONT \$20 00

### PRODUCTIVE GOLD MINE AND MACHINERY FOR SALE VERY CHEAP

The subscriber, desiring to retire from active business, offers for sale his well-known gold mine, "The Volcano," together with 640 acres of land surrounding it, and the machinery and paraphernalia incident to the business. Competent experts and judges unhesitatingly assert that the mine might yield \$1,327 a day if fully developed. Besides gold, the mine is believed to contain valuable and inexhaustible deposits of diamonds, silver, copper and

$\frac{1}{3}$   $\frac{2}{3}$   $\frac{1}{4}$   $\frac{1}{2}$       1 2 3 4 5 6 7 8 9 0       $\frac{1}{8}$   $\frac{3}{8}$   $\frac{5}{8}$   $\frac{7}{8}$

*Fonts do not contain spaces and quads*

AMERICAN TYPE FOUNDERS COMPANY

Poster Caledonian No 30

40 POINT

25 LB. FONT \$12 50

Experience has  
proved that the  
apprentice \$23

36 POINT

25 LB. FONT \$12 50

Experience proves  
that the apprentice  
foreshadows \$1234

28 POINT

25 LB. FONT \$12 50

EXPERIENCE proves  
that the beginner fore-  
shadows the workman,  
just as surely \$123456

*Fonts do not contain spaces and quads*

AMERICAN TYPE FOUNDERS COMPANY

Poster Caledonian No 30

22 POINT

25 LB. FONT \$12 50

**EXPERIENCE** proves that  
the apprentice foreshadows  
the workman, just as surely  
as the bend of the twig tells  
the inclination \$123456789

18 POINT

25 LB. FONT \$13 00

**EXPERIENCE** proves that the  
apprentice foreshadows the work-  
man, just as surely as the bend of  
the twig foretells the inclination  
of the tree. The upright, obedient,  
industrious lad will \$1234567890

12 POINT

25 LB. FONT \$13 50

**EXPERIENCE** proves that the apprentice  
foreshadows the workman, just as surely as  
the bend of the twig foretells the inclination  
of the tree. The upright, obedient, industri-  
ous lad will graduate a steady, skilful, and  
capable man, as unmistakably as the per-  
verse, idling, careless boy will ripen into a  
lazy, dissolute fellow. The fact \$1234567890

*Fonts do not contain spaces and quads*

AMERICAN TYPE FOUNDERS COMPANY

# UNCOUTH

Education is the  
proper means of  
training knaves  
for social events

# CHROMATIC

Printers are liberal  
in their ideas of the  
artistic color effects  
created by fine ink

*Fonts do not contain spaces and quads*

Poster Doric No 40

20 POINT

25 LB. FONT \$13 00

## **DISCOVERIES**

**Shrewd electricians have evidence that the human brain at work will evolve ample heat to run a motor**

18 POINT

25 LB. FONT \$13 00

## **GRAND BERTHS**

**There is no other nation in the world that the inborn instinct for travel is shown more than in the American. The comfort of tourists is amply considered**

12 POINT

25 LB. FONT \$13 50

## **INVENTIVE PRINTERS**

**Most printers have had the notion that they could invent something that would be of use in the trade; that they had an undeveloped idea for mechanism which would be in advance of those now in use. Those who have smothered their desire to perfect such ideas have done well, for many have come to grief before fortune**

*Fonts do not contain spaces and quads*

AMERICAN TYPE FOUNDERS COMPANY

**Poster Lightface No 45**

28 POINT

25 LB. FONT \$12 50

DEMONSTRATION

Candid and truthful men cannot wink out of sight the cruelties visited upon early colonizers by Indian raiders who inhabited the vast American Continent

22 POINT

25 LB. FONT \$12 50

ASTRONOMICAL

No telescope is required to see that the surface of the moon is covered in places by small spots or patches, which appear dark when compared with the more brilliant portions of the lunar surface surrounding them, and can be seen with an opera glass

*Fonts do not contain spaces and quads*

AMERICAN TYPE FOUNDERS COMPANY

## Poster Lightface No 45

18 POINT

25 LB. FONT \$13 00

### MELODIOUS REFRAINS

Music is the source of all our social pleasure; it soothes violent impulses of man, dignifies church ceremonies, and educates his most æsthetic taste

12 POINT

25 LB. FONT \$13 50

### EDUCATION AND ENJOYMENT

Milton was not only the grandest epic poet who has lived since Homer, but he was one of the most able schoolmasters of that period, and devised for all his pupils a plan of education in which the fatigues of study were wisely interspersed by intervals of music

10 POINT

25 LB. FONT \$18 25

### HANDSOME SCIENTIFIC INSTRUMENT

The chief thing in a telescope is the object-glass, which concentrates the rays of light at a focus, and these create an image of the object looked at. The image is in turn magnified by means of a powerful eyepiece resembling a microscope. A good telescope should bear a magnifying power of one hundred diameters for an inch of aperture

8 POINT

25 LB. FONT \$20 00

### CONTEMPLATING ENORMOUS PRODUCTIONS

Bicycle men assert that theirs is at the present time the largest specific manufacturing industry in America; that is to say, that there is no other single article whose production brings so large a remuneration to so large a colony of workers. It is variously estimated that from six hundred thousand to a million bicycles will be made in America this year. It is quite probable that the higher figure is nearer the truth. This denotes great foresight

*Fonts do not contain spaces and quads*

AMERICAN TYPE FOUNDERS COMPANY

# German Plain Faces

6 POINT GERMAN NO 412

Smallest font 25 lbs.

PRICE 64 CTS PER LB

Die hohe Stufe, welche die Buchdruckerkunst unter den Erfindungen des menschlichen Geistes einnimmt, hat die Ehre, die Geburtsstätte derselben zu sein, zum Gegenstande eines lebhaften noch nicht beendigten Streites gemacht, seit Strassburg, besonders aber seit Harlem es sich angelegen sein ließ, die Stadt Mainz aus ihrem früher unbestrittenen ausschließlichen Besitze, der von Harlem sogar als ein unredlicher angefochten wird, ganz oder doch größtentheils zu verdrängen. In den dadurch entstandenen Streitfragen herrscht das Vorurtheil, jene Kunst könne nur in einem einzigen Orte entstanden sein, und das Streben vor, diesem zu Gunst, Alles was ihre Erfindung dem Drange eines reif gewordenen Zeitbedürfnisses verdankt, was bis unmittelbar an ihre Schwelle vorbereitend und einleitend schon von Andern und selbst von ganzen Gewerben gesehen war, zu übersehen oder

1234567890

8 POINT GERMAN NO 412

Smallest font 25 lbs.

PRICE 52 CTS PER LB

Die hohe Stufe, welche die Buchdruckerkunst unter den Erfindungen des menschlichen Geistes einnimmt, hat die Ehre, die Geburtsstätte derselben zu sein, zum Gegenstande eines lebhaften noch nicht beendigten Streites gemacht, seit Strassburg, besonders aber seit Harlem es sich angelegen sein ließ, die Stadt Mainz aus ihrem früher unbestrittenen ausschließlichen Besitze, der von Harlem sogar als ein unredlicher angefochten wird, ganz oder doch größtentheils zu verdrängen. In den dadurch entstandenen Streitfragen herrscht das Vorurtheil, jene

1234567890

10 POINT GERMAN NO 412

Smallest font 25 lbs.

PRICE 46 CTS PER LB

Die hohe Stufe, welche die Buchdruckerkunst unter den Erfindungen des menschlichen Geistes einnimmt, hat die Ehre, die Geburtsstätte derselben zu sein, zum Gegenstande eines lebhaften noch nicht beendigten Streites gemacht, seit Strassburg, besonders aber seit Harlem es sich angelegen sein ließ, die Stadt Mainz aus ihrem früher unbestrittenen ausschließlichen Besitze, der von Harlem sogar als ein unredlicher an-

1234567890

11 POINT GERMAN NO 412

Smallest font 25 lbs.

PRICE 44 CTS PER LB

Die hohe Stufe, welche die Buchdruckerkunst unter den Erfindungen des menschlichen Geistes einnimmt, hat die Ehre, die Geburtsstätte derselben zu sein, zum Gegenstande eines lebhaften noch nicht beendigten Streites gemacht, seit Strassburg, besonders aber seit Harlem es sich angelegen sein ließ, die Stadt Mainz aus ihrem früher unbestrittenen ausschließlichen Besitze, der von Harlem sogar als ein un-

1234567890

12 POINT GERMAN NO 412

Smallest font 25 lbs.

PRICE 42 CTS PER LB

Die hohe Stufe, welche die Buchdruckerkunst unter den Erfindungen des menschlichen Geistes einnimmt, hat die Ehre, die Geburtsstätte derselben zu sein, zum Gegenstand eines lebhaften noch nicht beendigten Streites gemacht, seit Strassburg, besonders aber seit Harlem es sich angelegen sein ließ, die Stadt Mainz aus ihrem früher unbestrittenen ausschließ-

1234567890

AMERICAN TYPE FOUNDERS COMPANY



## German Poster Series

---

18 POINT GERMAN NO 32

Smallest font 25 lbs

PRICE 52 CTS PER LB

Natur! Wir sind von ihr umgeben und umschlungen—unvermögend, aus ihr herauszutreten, und unvermögend, tiefer in sie hineinzufommen. Angebeten und ungewarnt nimmt sie uns in den Umlauf ihres Tages auf und treibt sich mit uns fort, bis

1234567890

24 POINT GERMAN NO 31

Smallest font 25 lbs

PRICE 50 CTS PER LB

Natur! Wir sind von ihr umgeben und umschlungen—unvermögend, aus ihr herauszutreten, und unvermögend, tiefer in sie

1234567890

28 POINT GERMAN NO 32

Smallest font 25 lbs

PRICE 50 CTS PER LB

Natur! Wir sind von ihr umgeben und umschlungen, unvermögend aus ihr herauszutreten

1234567890

---

AMERICAN TYPE FOUNDERS COMPANY

# Self Spacing German

6 POINT NO 42

Unit of measure of this font is 12 to Pica

Auf keinem Gebiete waren die Fortschritte seit vier Jahrhunderten so gering wie in der Kunst des Schriftsetzens. Die hier und da in Gebrauch befindlichen Maschinen sind durchaus unvollkommen; die bei weitem größte Masse der üblichen Schrift ist noch genau der Art wie vor vierhundert Jahren. Wenn Franklin heute wieder vor dem Kasten stände, würde er nichts Neues zu lernen haben. Die Schriftgießerei ist hinter der wunderbaren Vervollkommnung der Pressen vollständig zurückgeblieben; die vergrößerte Geschwindigkeit im Schriftsetzen beruht ausschließlich in der Vermehrung der Kästen. Alle Bemühungen, diesem Uebelstande abzuhelpfen, gingen darauf hinaus, Setzmaschinen zu erfinden, statt die Art und Weise des Handsetzens zu verbessern. Eins der Haupthindernisse, welches den Setzmaschinen im Wege stand, ist die Nothwendigkeit, mit der Hand zu „justiren“. Daran scheiterte hauptsächlich die Einführung dieser Maschinen. Es liegt daher auf der Hand, daß jeder Plan zur Verbesserung unserer Setz-Methoden in erster Linie die Justirung zu vereinfachen hat, denn da dies der Punkt ist, um den sich die Sache dreht, so muß durch eine Vereinfachung des Ausschließens und Justirens die Leichtigkeit und Geschwindigkeit des Hand-Schriftsetzens wachsen. Dies geschieht durch Benton's selbst-ausschließende Schrift. Genau genommen, kann man nicht eigentlich von Selbst-Ausschließen sprechen, jedoch diese Arbeit ist durch die Erfindung so einfach und leicht geworden, daß der Ausdruck „Selbst-Ausschließung“ wohl berechtigt sein dürfte. Die Breiten von Buchseiten, vielen Druckerarbeiten und Zeitungskolumnen belaufen sich auf eine gewisse Anzahl von Cicero ems und daher muß auch das Cicero em als die Basis für die selbst-ausschließende Schrift angenommen werden. Der allergeringste Raum bei allen Güssen ist ein genauer Bruchtheil von Cicero und dieser Bruchtheil wird die Maßeinheit genannt. Alle diese Schriften, Spatien und Quadrate im Guß bestehen aus einer bestimmten Mehrtheit dieser Einheit, so daß alle Averse genau zusammenpassen. Diese Einheit kann ein Sechstel, ein Siebentel, ein Achtel, ein Zehntel, u. s. w., eines Cicero em sein, wie man will, um enge, mittlere oder weite Abdrücke zu erhalten. Jeder Setzer kann sehen, daß irgend eine Linie, welche mit selbst-ausschließender Schrift gesetzt werden mag, aus einer bestimmten Anzahl von Einheiten bestehen muß. Mehrere Experimente mit dieser neuen Schrift

A B C D E F G H I J K L M N O P Q R S T U V W X Y Z

1234567890

8 POINT NO 43

Unit of measure of this font is 12 to Pica

Auf keinem Gebiete waren die Fortschritte seit vier Jahrhunderten so gering wie in der Kunst des Schriftsetzens. Die hier und da in Gebrauch befindlichen Maschinen sind durchaus unvollkommen; die bei weitem größte Masse der üblichen Schrift ist noch genau der Art wie vor vierhundert Jahren. Wenn Franklin heute wieder vor dem Kasten stände, würde er nichts Neues zu lernen haben. Die Schriftgießerei ist hinter der wunderbaren Vervollkommnung der Pressen vollständig zurückgeblieben; die vergrößerte Geschwindigkeit im Schriftsetzen beruht ausschließlich in der Vermehrung der Kästen. Alle Bemühungen, diesem Uebelstande abzuhelpfen, gingen darauf hinaus, Setzmaschinen zu erfinden, statt die Art und Weise des Handsetzens zu verbessern. Eins der Haupthindernisse, welches den Setzmaschinen im Wege stand, ist die Nothwendigkeit, mit der Hand zu „justiren“. Daran scheiterte hauptsächlich die Einführung dieser Maschinen. Es liegt daher auf der Hand, daß jeder Plan zur Verbesserung unserer Setz-Methoden in erster Linie die Justirung zu vereinfachen hat, denn da dies der Punkt ist, um den sich die Sache dreht, so muß durch eine Vereinfachung des Ausschließens und Justirens die Leichtigkeit und Geschwindigkeit des Hand-Schriftsetzens wachsen. Dies geschieht durch Benton's selbst-ausschließende Schrift. Genau genommen, kann man nicht eigentlich von Selbst-Ausschließen sprechen, jedoch diese Arbeit ist durch die Erfindung so einfach und leicht geworden, daß der Ausdruck „Selbst-Ausschließung“ wohl berechtigt sein dürfte. Die Breiten von Buchseiten, vielen Druckerarbeiten und Zeitungskolumnen belaufen

A B C D E F G H I J K L M N O P Q R S T U V W X Y Z

1234567890

*Smallest font sold, 25 lbs. Prices same as for Roman body type*

AMERICAN TYPE FOUNDERS COMPANY

# Self Spacing German

*For description of Self Spacing Type, see page 44*

9 POINT NO 41

Unit of measure of this font is 10 to Pica

Auf keinem Gebiete waren die Fortschritte seit vier Jahrhunderten so gering wie in der Kunst des Schriftsetzens. Die hier und da in Gebrauch befindlichen Maschinen sind durchaus unvollkommen; die bei weitem größte Masse der üblichen Schrift ist noch genau der Art wie vor vierhundert Jahren. Wenn Franklin heute wieder vor dem Kasten stände, würde er nichts Neues zu lernen haben. Die Schriftgießerei ist hinter der wunderbaren Vervollkommnung der Pressen vollständig zurückgeblieben; die vergrößerte Geschwindigkeit im Schriftsetzen beruht ausschließlich in der Vermehrung der Kästen. Alle Bemühungen diesem Uebelstande abzuhelpfen, gingen garauf hinaus, Segmaschinen zu erfinden, statt die Art und Weise des Handsetzens zu verbessern. Eins der Haupthindernisse, welches den Segmaschinen im Wege stand, ist die Nothwendigkeit, mit der Hand zu „justiren“. Daran scheiterte hauptsächlich die Einführung dieser Maschinen. Es liegt daher auf der Hand, daß jeder Plan zur Verbesserung unserer Seg-Methoden in erster Linie die Justirung zu vereinfachen hat, denn da dies der Punkt ist, um den sich die Sache dreht, so muß durch eine Vereinfachung des Ausschließens und Justirens die Leichtigkeit und Geschwindigkeit des Hand-Schriftsetzens wachsen. Dies geschieht durch Benton's selbst-ausschließende Schrift. Genau genommen,

A B C D E F G H I J K L M N O P Q R S T U V W X Y Z

1234567890

10 POINT NO 40

Unit of measure of this font is 9 to Pica

Auf keinem Gebiete waren die Fortschritte seit vier Jahrhunderten so gering wie in der Kunst des Schriftsetzens. Die hier und da in Gebrauch befindlichen Maschinen sind durchaus unvollkommen; die bei weitem größte Masse der üblichen Schrift ist noch genau der Art wie vor vierhundert Jahren. Wenn Franklin heute wieder vor dem Kasten stände, würde er nichts Neues zu lernen haben. Die Schriftgießerei ist hinter der wunderbaren Vervollkommnung der Pressen vollständig zurückgeblieben; die vergrößerte Geschwindigkeit im Schriftsetzen beruht ausschließlich in der Vermehrung der Kästen. Alle Bemühungen, diesem Uebelstande abzuhelpfen, gingen darauf hinaus, Segmaschinen zu erfinden, statt die Art und Weise des Handsetzens zu verbessern. Eins der Haupthindernisse, welches den Segmaschinen im Wege stand, ist die Nothwendigkeit, mit der Hand zu „justiren“. Daran scheiterte hauptsächlich die Einführung dieser Maschinen. Es liegt daher auf der Hand, daß jeder Plan zur Verbesserung unserer Seg-Methoden in erster Linie die Justirung zu vereinfachen hat, denn da dies der Punkt

A B C D E F G H I J K L M N O P Q R S T U V W X Y Z

1234567890

*Smallest font sold, 25 lbs. Prices same as for Roman body type*

AMERICAN TYPE FOUNDERS COMPANY

German Poster Series

60 POINT GERMAN NO 30

25 LB FONT \$13 00

Schöne Bilder  
Neues Kleinod

40 POINT GERMAN NO 32

25 LB FONT \$13 50

Werke für Musiker  
Deutsche Melodien

48 POINT GERMAN NO 31

25 LB FONT \$13 50

Wirf nicht Steine  
Heiliges Denkmal

40 POINT GERMAN NO 31

25 LB FONT \$13 50

Schätze deine Eltern  
Glückliche Menschen

AMERICAN TYPE FOUNDERS COMPANY

German No 42

72 POINT

3 A 4 a \$13 10

Gutenberg

60 POINT

4 A 8 a \$13 40

Zeitschriften

48 POINT

6 A 10 a \$10 80

Handels-Verkehr

40 POINT

9 A 16 a \$10 40

Deutsche Gesellschaften

28 POINT

16 A 60 a \$17 20

Jagdbezirke für Rothkehlchen

24 POINT

18 A 80 a \$13 00

Schlaraffenland  
1 2 3 4 5 6

22 POINT

30 A 150 a \$21 05

Benachrichtigung  
1 2 3 4 5 6 7

Condensed German Title

36 POINT

6 A 10a \$7 15

# Jugend und Freiheit

28 POINT

8 A 10a \$4 80

## Berichte der Naturforscher

24 POINT

9 A 16a \$5 05

## Wahrer Gewerbefleiß und Frohsinn

18 POINT

18 A 30a \$5 35

## Kunst-, Wissenschaft- und Literatur-Ausstellung

14 POINT

18 A 30a \$3 85

Das Buch der Natur liegt seit Jahrtausenden vor de

12 POINT

16 A 30a \$3 10

Das Buch der Natur liegt seit Jahrtausenden vor dem Blicke

11 POINT

18 A 30a \$2 45

Das Buch der Natur liegt aufgeschlagen vor dem Blicke des Menschen seit Jahrtausenden. Es ist in

10 POINT

18 A 30a \$2 30

Das Buch der Natur liegt seit Jahrtausenden vor dem Blicke des Menschen aufgeschlagen. Es ist in groß

9 POINT

25 A 80a \$3 80

Das Buch der Natur liegt seit Jahrtausenden aufgeschlagen vor dem Blicke des Menschen. Es ist in großen und herrlich

8 POINT

25 A 60a \$3 65

Das Buch der Natur liegt seit Jahrtausenden aufgeschlagen vor dem Blicke des Menschen. Es ist in großen und herrlich

7 POINT

25 A 80a \$3 10

Das Buch der Natur liegt seit Jahrtausenden aufgeschlagen vor dem Blicke des Menschen. Es ist in großen und herrlichen Zügen geschrieben, es enthält das Wunderbare und das Nützliche, und ne-

8 POINT

25 A 60a \$2 80

Das Buch der Natur liegt seit Jahrtausenden aufgeschlagen vor dem Blicke des Menschen. Es ist in großen und herrlichen Zügen geschrieben, es enthält das Wunderbare und das Nützliche, und neben dem

1 2 3 4 5 6 7 8 9 0

1 2 3 4 5 6 7 8 9 0

German Title

36 POINT

6 A 10 a \$7 65

Schöne Quafelchen

28 POINT

6 A 10 a \$5 50

Sin zum Sonnenlichte

24 POINT

9 A 16 a \$7 30

Wanderbuch eines Druckers

16 POINT

16 A 30 a \$7 35

Auszug über die  
Nachtschwärmer

12 POINT

18 A 30 a \$4 40

Kühne Versäumnis der  
Wissenschaft und Kunst

11 POINT

18 A 30 a \$3 10

Das Buch der Natur liegt  
seit Jahrtausenden vor dem  
Blicke des Menschen. Es

10 POINT

16 A 30 a \$3 20

Das Buch der Natur liegt  
seit Jahrtausenden aufge-  
schlagen vor dem Blicke des

9 POINT

18 A 30 a \$2 55

Das Buch der Natur liegt seit  
Jahrtausenden vor dem Blicke  
des Menschen. Es ist in großen

8 POINT

18 A 30 a \$2 70

Das Buch der Natur liegt seit  
Jahrtausenden vor dem Blicke  
des Menschen aufgeschlagen. Es

7 POINT

25 A 60 a \$3 50

Das Buch der Natur liegt seit Jahrtausenden  
aufgeschlagen vor dem Blicke des Men-  
schen. Es ist in großen und herrlichen

1 2 3 4 5 6 7 8 9 0

6 POINT

25 A 60 a \$3 25

Das Buch der Natur liegt seit Jahrtausenden  
aufgeschlagen vor dem Blicke des Men-  
schen. Es ist in großen und herrlichen Züg

1 2 3 4 5 6 7 8 9 0

48 POINT

3 A 8 a \$7 35

# Erfinder Gutenberg

38 POINT

4 A 10 a \$5 40

## Stammt aus dem sehr alten

24 POINT

5 A 16 a \$3 80

## Ritterlichen Geschlecht der Gensfleisch zu Mainz, von welchem uns noch viele

18 POINT

8 A 25 a \$3 55

## Nachrichten überkommen sind. • • Im Jahre 1332 stand sein Urgroßvater Frielo Gensfleisch, damals Rathsherr, beim Aufstande der Zünfte gegen den

12 POINT

15 A 45 a \$3 25

Adel der mächtigen Mainz an der Spitze der Patricier. • Seine zwei Söhne, Peter und Claus, von welchen jener Bürgermeister

10 POINT

18 A 50 a \$3 00

Seitenlinie • • welche nach einem von Peters Gattin G. Gelthus zur Laden zugebrachten Stammhause den Beinamen zur Laden annahm. • • Der Enkel Peters, welcher ebenfalls den

8 POINT

18 A 52 a \$2 70

Wurde und die Hauptlinie des Geschlechts fortsetzte, während dieser eine Seitenlinie stiftete, deren Abkommen in dem Jahre 1432 den Beinamen Sorgenloch oder Selgenloch annahm. • Der Sohn Peters, Frielo, gründete in der Hauptlinie ebenfalls eine

8 POINT

20 A 60 a \$2 40

Namen Frielo führte, nahm die Elise zum Gutenberg, die Erblochter des mit ihr erlöschenden Geschlechts der Zammerer zum Gutenberg zur Gemahlin, und zeugte mit ihr zwei Söhne, Frielo und Johann, von welchen der letztere sich Johann Gensfleisch zum Gutenberg nannte, und die vereinigten Namen der beiden alten Geschlechter durch die Erfindung der Buchdruckerkunst den spätesten Nachkommen überliefert hat. • •



## German Title No 2

26 POINT

4 A 10 a \$3 80

**Glückliche junge Arbeiter**

22 POINT

7 A 20 a \$4 75

**Thue Recht und seheue Niemand**

18 POINT

7 A 20 a \$3 15

**Großes Konzert im Walde  
Das Abschiedslied der fröhlichen Sänger**

14 POINT

8 A 25 a \$2 70

**Praktische Theorie  
Sehr einfach und deutlich**

12 POINT

9 A 30 a \$2 65

**Der König der Wüste  
Ermahnung an seine Rekruten**

10 POINT

12 A 40 a \$2 45

**Wenn Weiber schweigen  
Arrangirt Mephisto seinen Reigen  
1234567890**

8 POINT

15 A 50 a \$2 50

**Traumbuch für verliebte Backfische  
Seifenblasen und prächtige Luftschlöffer  
1234567890**

## Boldface German

12 POINT

9 A 30 a \$3 00

**Schwabenstreiche der deutschen Studenten  
Das Heidelberger Faß hat so manchen Durst gestillt**

10 POINT

12 A 40 a \$3 00

**Speziell für Patrioten  
Abfahrt deutscher Soldaten**

9 POINT

15 A 50 a \$3 35

**Eine Rose ohne Dornen  
Ist wie ein Baum ohne Blätter**

8 POINT

15 A 50 a \$2 95

**Wunderbare Erfindungen  
Photographien der Sternentwelt  
1234567890**

6 POINT

15 A 50 a \$2 60

**Unterirdische Tiefen der Wälder  
Die Lebensadern der Felder und Quellen  
1234567890**

AMERICAN TYPE FOUNDERS COMPANY

30 POINT

8 A 20 a \$7 10

# Das Lied der Glocke Ewiger Kampf um Freiheit

24 POINT

8 A 25 a \$5 80

## Keine Rose ohne Dornen Vorsicht ist die Mutter der Weisheit

18 POINT

10 A 30 a \$4 95

## Arbeit ist des Bürgers Zierde Ein ehrenvoller Name und guter Charakter

14 POINT

12 A 40 a \$4 80

## Muntere Geister Biel Witz und Humor

12 POINT

12 A 40 a \$3 35

## Ohne Mühe kein Preis Große Meister schöner Künste

10 POINT

12 A 40 a \$2 85

## Reichste Auswahl neuer Schriften und guter Materialien

9 POINT

12 A 50 a \$2 60

## Mit Ehrlichkeit und Fleiß Kommt man am besten durch die Welt

8 POINT

15 A 50 a \$2 80

## Das menschliche Leben bietet dem Scharfen Beobachter ein gutes Lehrbild 1234567890

8 POINT

15 A 50 a \$2 15

## Morgenstunde hat Gold im Munde Man soll niemals den Tag vor dem Abend loben 1234567890

40 POINT

4 A 10 a \$6 55

# Schatzkammer-Gericht

26 POINT

5 A 15 a \$4 90

## Unruhige Gesellschaft Praktische starke Germanen

22 POINT

6 A 20 a \$4 05

## Fürchterlicher Donnerschlag Umsturz der Monarchie in Frankreich

18 POINT

6 A 20 a \$2 70

### Sanfte Schritte Tragischer Aufenthalt

12 POINT

12 A 40 a \$3 00

### Sämtliche Schriften Messinglinien und Ornamente

10 POINT

12 A 40 a \$2 25

### Humoristische Erzählungen Unterhaltende Lektüre und Aufsätze

6 POINT

15 A 50 a \$2 30

### Geschlechts- und Nervenleiden Ansicht medizinischer Sachverständiger 1234567890

14 POINT

9 A 30 a \$2 00

### Frische reine Luft Windmühlen für Fabriken

11 POINT

12 A 40 a \$2 40

### Berzauberte Trinkschalen Ehrenmoment der Freiheitskämpfer

9 POINT

15 A 50 a \$2 60

### Ein herrlicher Sonnenaufgang Fruchtbare Resultate einer Untersuchung

6 POINT

15 A 50 a \$2 00

### Originelle Karikaturen und Witze Besprechung über Tagesereignisse unserer Politik 1234567890

48 POINT

3 A 8 a \$11 40

Reiche Fürsten

36 POINT

3 A 8 a \$7 00

Alterthümlichkeit!

30 POINT

4 A 10 a \$8 00

Herenmeister Zeitung

20 POINT

5 A 15 a \$5 00

Sieben Herren Kamen Gestern  
Deutsche Männer

18 POINT

6 A 18 a \$4 00

Es macht der Saft der Purpurtraube  
des Menschen Herz gesund

14 POINT

7 A 20 a \$3 75

Bekränzt mit Laub  
das volle Glas

12 POINT

8 A 24 a \$3 50

Des Meeres Gewässer  
in Bewegung gesetzt

10 POINT

10 A 30 a \$3 25

Preiset unsere Reben  
Sagt ein altes Sprichwort  
1 2 3 4 5 6 7 8 9 0

8 POINT

14 A 42 a \$3 00

Bildung der Menschen  
Nach Regen folgt Sonnenschein  
1 2 3 4 5 6 7 8 9 0

48 POINT

3 A 8 a \$8 95

Pracht = Gebäude

38 POINT

4 A 8 a \$4 50

Elegante Schrift  
Hübsche blaue Farben

30 POINT

5 A 10 a \$3 85

Originelle Novellen  
Geschichten und Loblieder

22 POINT

5 A 15 a \$3 15

Tanzschulen  
Lustige Knaben

14 POINT

9 A 30 a \$3 20

Schwarze Augen  
Bildschöne Zigeunerin

12 POINT

9 A 30 a \$2 35

Berliner Promenaden  
Und Anlagen der Umgegend

10 POINT

12 A 40 a \$2 20

Drucksachen für moderne  
Zuschneider und alte Dummköpfe

8 POINT

15 A 50 a \$2 85

Nachrichten aus der Heimath  
Glänzende Eröffnung der Ausstellung  
1234567890

8 POINT

15 A 50 a \$1 95

Die Schriften von Johann Gutenberg  
Gleich nach der Erfindung der Buchdruckerkunst  
1234567890

# Ornamental Cast Initials

SERIES NO 1148 <sup>o</sup> PER SET \$3 50 EACH 30 CENTS FOR TWO COLORS PER SET \$7 00 EACH 60 CENTS



SERIES NO 1147 <sup>o</sup> PER SET \$2 25 FOR TWO COLORS \$4 50



SERIES NO 441 <sup>c</sup>

SINGLE LETTER WITH PENDANTS 40 CENTS  
PER SET WITH PENDANTS AND SPACES \$7 00

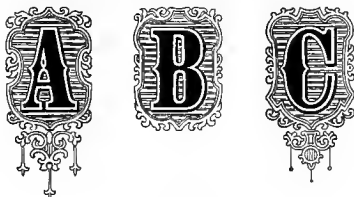

SERIES NO 440 <sup>c</sup>

SINGLE LETTER WITH PENDANTS 40 CENTS  
PER SET WITH PENDANTS \$5 00



48 POINT ART INITIALS <sup>f</sup>  
PER SET WITH ORNAMENTS \$3 00

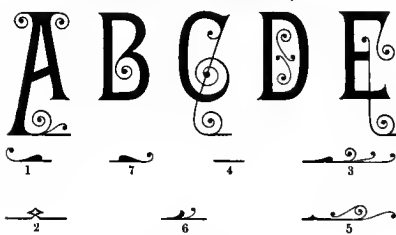

72 POINT ART INITIALS <sup>f</sup>  
PER SET WITH ORNAMENTS \$4 00

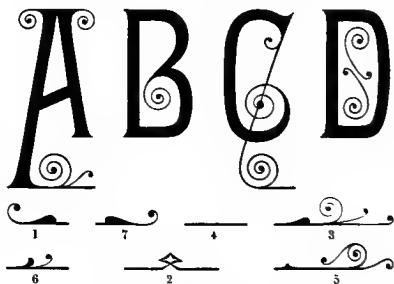

SERIES NO 1133 <sup>o</sup>  
PER SET \$3 50 SINGLE LETTER 40 CENTS

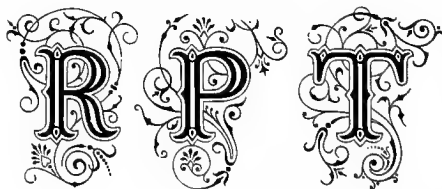

SERIES NO 1155 <sup>c</sup>  
PER SET \$3 50 SINGLE LETTER 40 CENTS



AMERICAN TYPE FOUNDERS COMPANY

# Ornamental Cast Initials

SERIES NO 321 ORNAMENTED  
PER SET \$7 50 SINGLE LETTER 50 CENTS



SERIES NO 321 PLAIN  
PER SET \$6 00 SINGLE LETTER 50 CENTS



SERIES NO 320 PLAIN  
PER SET \$3 50 SINGLE LETTER 35 CENTS



SERIES NO 320 ORNAMENTED  
PER SET \$5 00 SINGLE LETTER 35 CENTS



*Series No. 320 and No. 321 are designed to work together in colors*

SERIES NO 1143 PER SET \$3 50

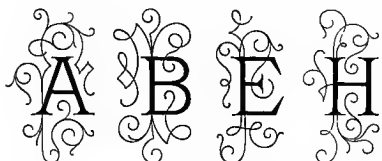

SERIES NO 1142 PER SET \$2 00



SERIES NO 1132 PER SET \$3 50  
SINGLE LETTER 40 CENTS



SERIES NO 1136 PER SET \$2 00



46 POINT MORTISED NO 2

3 A \$6 00

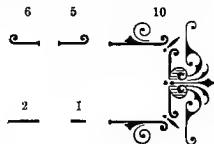
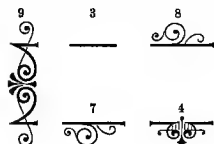
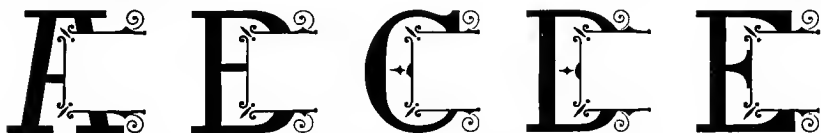

AMERICAN TYPE FOUNDERS COMPANY

# Electrotyped Initials

SPHINX SERIES \*      INDEX INITIALS      ACORN SERIES NO 71

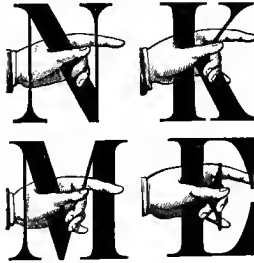

INDEX INITIALS  
Second Series

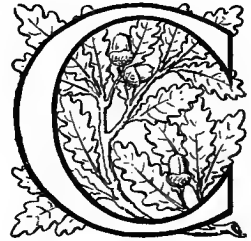
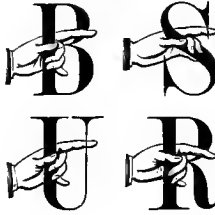

WAVERLEY SERIES NO 74 \*

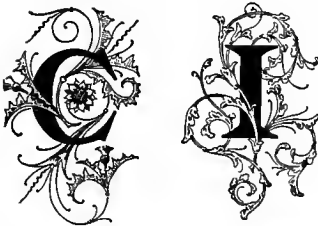

ACORN SERIES NO 72 \*

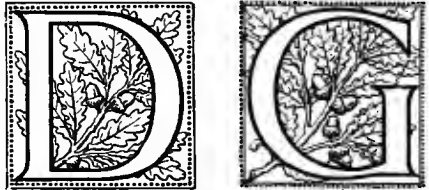

ACORN SERIES NO 73 \*



WAVERLEY SERIES NO 75 \*



SERIES NO 421      c



PRICES.—Sphinx Series, per Set, \$20.00; Single Letter, \$1.00. Index Initials, per Set, \$10.00; Single Letter, 50 cts. Index Initials, Second Series, per Set, \$8.00; Single Letter, 40 cts. Acorn Series, No. 71, per Set, \$20.00; Single Letter, \$1.00. Acorn Series, No. 72, per Set, \$15.00; Single Letter, 75 cts. Acorn Series, No. 73, per Set, \$12.00; Single Letter, 60 cts. Waverley Series, No. 74, Single Letter, 60 cts. Waverley Series, No. 75, Single Letter, 75 cts. Series No. 421, per Set, \$7.00; Single Letter, 35 cts.

AMERICAN TYPE FOUNDERS COMPANY



# Electrotyped Initials

MORRIS SERIES NO 76



SERIES NO 1156



MORRIS SERIES NO 77



SERIES NO 442



SERIES NO 1159

Each in three pieces



MORRIS SERIES NO 76



SERIES NO 311



SERIES NO 315



CUPID INITIALS



RENATE SERIES NO 70



SERIES NO 426



RENATE SERIES NO 69



PRICES:—Morris Series No. 76, Single Letter, 75 cts. Morris Series No. 77, Single Letter, 60 cts. Morris Series No. 78, Single Letter, 50 cts. Series No. 315, 442, and Cupid Initials, per Set, \$10.00; Single Letter, 50 cts. Series No. 311, per Set, \$8.00; Single Letter, 40 cts. Series No. 1159, per Set, with Ornaments, \$4.50; Single Letter, 40 cts. Series No. 426, per Set, \$7.00; Single Letter, 35 cts. Renate Series No. 69, per Set, \$15.00; Single Letter, 75 cts. Renate Series No. 70, per Set, \$12.00; Single Letter, 60 cts.

AMERICAN TYPE FOUNDERS COMPANY

# Chessmen and Checkers

24 POINT CHESSMEN

PER FONT WITH RULES \$4 80

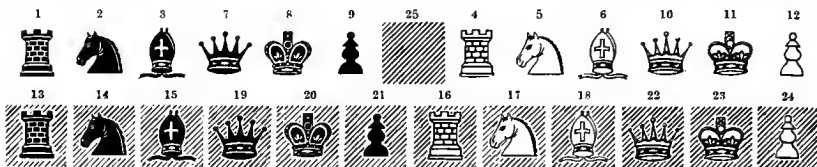

20 POINT CHESSMEN

PER FONT WITH RULES \$4 80

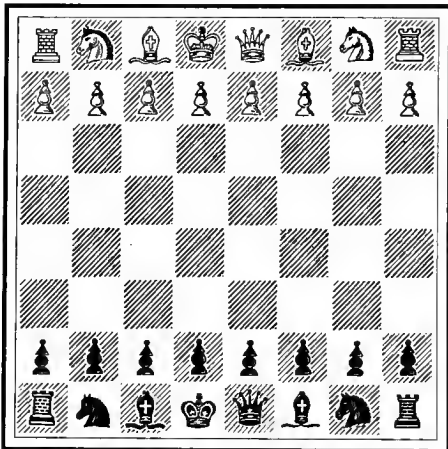

18 PT CHECKERS

PER FONT WITH RULES \$3 40



20 PT CHECKERS

PER FONT WITH RULES \$3 40



24 PT CHECKERS

PER FONT WITH RULES \$3 40



16 PT CHESSMEN

PER FONT WITH RULES \$4 80

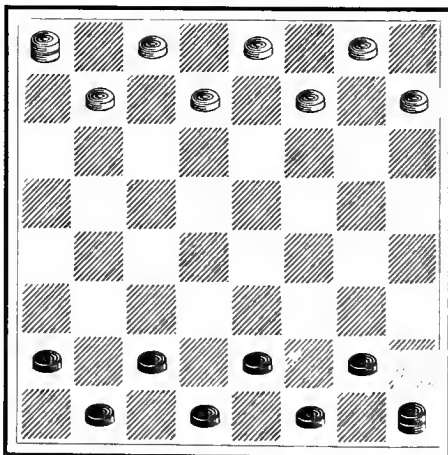
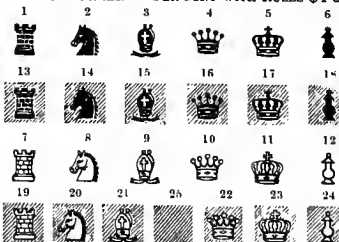

11 POINT CHECKERS



PER FONT WITH RULES \$2 00

AMERICAN TYPE FOUNDERS COMPANY

## Card Pips

32 POINT SERIES 1  
PER FONT 52 PIECES \$5 00

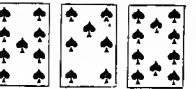
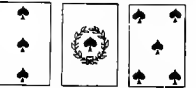
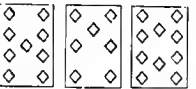
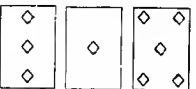
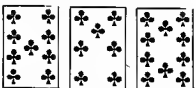
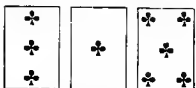
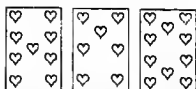
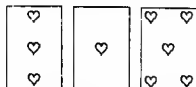

## Recipe Marks

15 CTS. PER SET



Nos. 305 and 325, 5 cts. each; Nos. 306, 307, 308, 326, 327 and 328, 10 cts. each;  
Nos. 309, 310, 329 and 330, 15 cts. each; No. 1131, 25 cts.



Nos. 311 and 312, 15 cts. each;  
Nos. 313, 314 and 315, 10 cts. each;  
No. 316, 5 cts.

## Locus Sigilli



A. 10 cts.

B. 15 cts.

C. 25 cts.

D. 30 cts.

F. 25 cts.

G. 25 cts.

## Arrows

## Whist Markers

6 POINT 15 CTS. PER SET

18 POINT \$1 00 PER POUND



## Card Indicators

24 PT PER FONT \$1 75

6 POINT PER FONT \$5 50



12 PT PER FONT \$1 00



3 ♠	A ♠	4 ♠	♣ 4
6 ♦	J ♠	K ♦	A ♦
7 ♦	9 ♦	2 ♦	Q ♦
♥ 9	♥ 10	5 ♦	10 ♦
♣ 2	♣ A	♣ 3	♣ 7
♥ 2	♣ J	♣ Q	♣ K
♥ 3	♥ 6	♥ A	♥ 4
2 ♠	♣ 5	K ♠	♥ 5
5 ♠	♣ 6	7 ♠	8 ♦
6 ♠	♣ 9	8 ♠	4 ♦
9 ♠	10 ♠	10 ♠	3 ♦
♥ Q	♥ K	J ♠	♣ 8
♥ 7	♥ 8	Q ♠	♥ J

# United States Signal Flags

36 POINT PER SET \$1 25

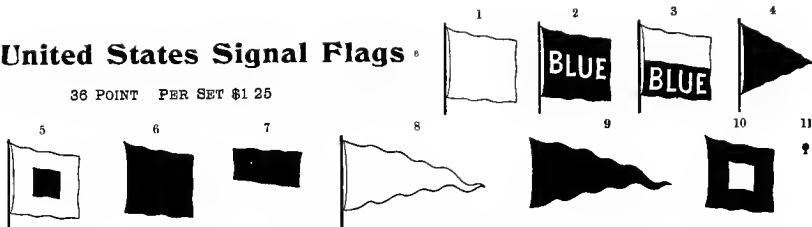

24 POINT PER SET \$1 00



# Five-Pointed Stars

Nos. 301 to 304, 15 cents per set of four each; Nos. 305, 306, 5 cents each; Nos. 307, 308, 312, 313, 314, 10 cents each; Nos. 309, 310, 315, 316, 15 cents each; Nos. 311, 317, 20 cents each.

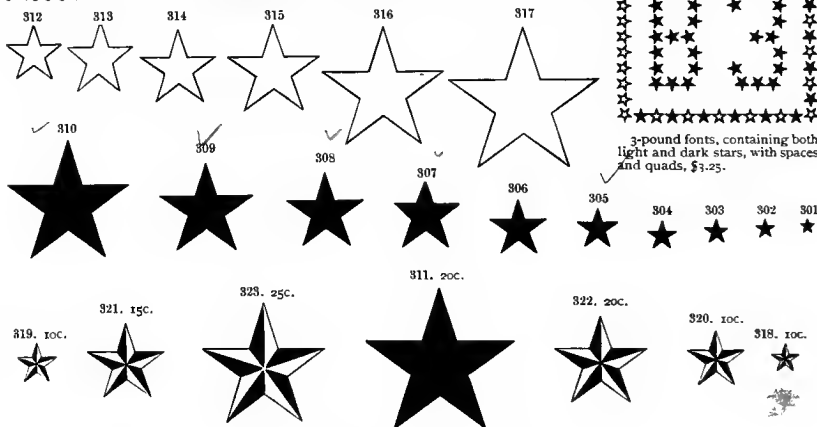

# Maltese Crosses

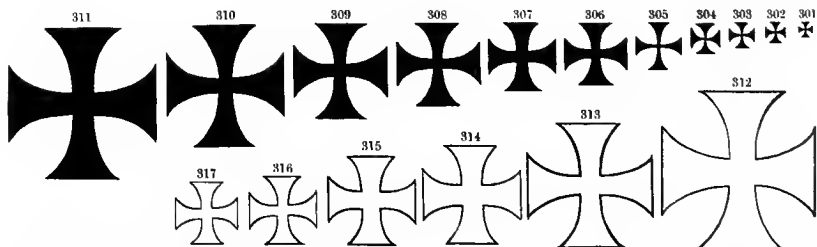

Nos. 301 to 304, 15 cents per set of four each; No. 305, 5 cents; Nos. 306, 307, 316, 317, 10 cents each; Nos. 308, 309, 314, 315, 15 cents each; Nos. 310, 313, 20 cents each; Nos. 311, 312, 25 cents each.

AMERICAN TYPE FOUNDERS COMPANY

# Index Cuts

For Larger Fists, see Cut Book

No. 3218A. 60 cts.



No. 3220A. 60 cts.

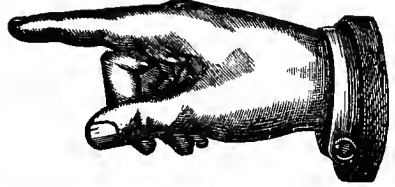

No. 3850B. 40 cts.



No. 3882B. 25 cts.



No. 219R. 15 cts.



No. 3851B. 40 cts.



No. 3883B. 25 cts.



No. 218R. 15 cts.



No. 3853B. 25 cts.



No. 3854B. 50 cts.



No. 3852B. 25 cts.



No. 3847B. 30 cts.



No. 3855B. 50 cts.



No. 3846B. 30 cts.



No. 558B. 15 cts.



No. 556B. 15 cts.



No. 554B. 10 cts.



No. 552B. 10 cts.



No. 550B. 10 cts.



No. 549B. 10 cts.



No. 551B. 10 cts.



No. 553B. 10 cts.



No. 555B. 15 cts.



No. 557B. 15 cts.



No. 547B. 5c.



No. 546B. 5c.



No. 546B. 5c.



No. 548B. 5c.



## Black Fists

Font containing two of each, Nos. 545 to 553,  
Price, \$1.25

AMERICAN TYPE FOUNDERS COMPANY

## Pointers €

PRICE PER FONT \$1 25

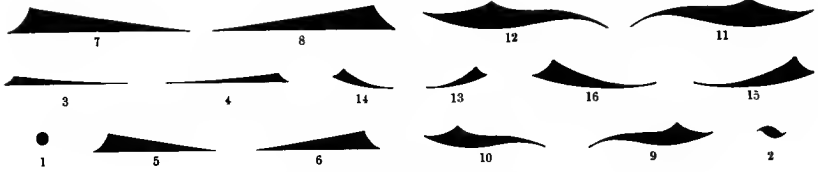

## Shaded Pointers €

PRICE PER FONT \$1 25

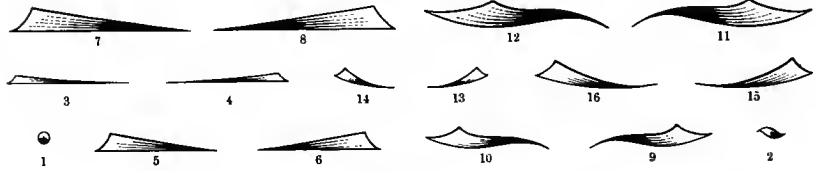

## Contour Pointers €

PRICE PER FONT \$1 25

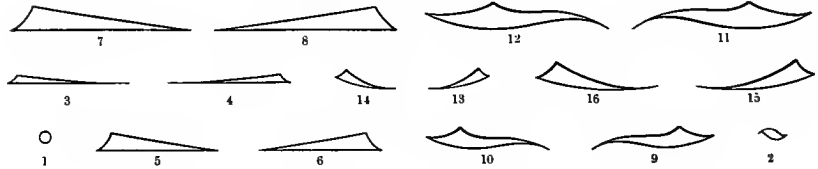

## Copper Alloy Imprints

Cast in one piece, any of the faces here shown, at the following prices: 100 of any one kind for \$8.00, net. 50 of any one kind for \$5.00, net.

1  
**JOHN POLHEMUS PRINTING CO.**  
 2  
**J. J. LITTLE & CO., PRINTERS.**  
 3  
**THEO. L. DEVINNE & CO., NEW YORK.**  
 4  
**E. PARKE COBY & CO.**

5  
**PETER DE BAUN & CO.**  
 6  
**J. W. PRATT & SON.**  
 7  
**JAMES A. ROGERS.**  
 8  
**WM. J. BRODERICK.**

If imprints are wanted longer than 1¼ in. in length, they will have to be made in two or more pieces, and \$3.00 extra per 100 will be charged for each extra piece.

### INTELLIGENCER PRINT, WHEELING.

BILLIES, "THE" PRINTER, ROCHESTER, N. Y.

[COPYRIGHTED]

C. E. NORTHRUP, PRINTER, BUFFALO, N. Y.

COPYRIGHT, 1887, BY KOPPLER & SCHWARZMANN

PRESS OF STYLES & CASH, NEW YORK

RODERS & SHERWOOD, NEW YORK.

**WM. P. BENNETT, PRINT. PITTSBURGH.**

STYLES & CASH, N. Y.

PRESS OF STYLES & CASH, N. Y.

**ALBERT B. KING, 88 WILLIAM ST., N. Y.**

FUSEY & TROXELL, PRINTERS AND STATIONERS, 1388 BROADWAY, N. Y.

THOMSON & CO., PRINTERS, 55 CITY ST. N. Y.

**THE EICHBAUM PRESS, PITTSBURGH.**

## AMERICAN TYPE FOUNDERS COMPANY

## Palmetto Ornaments

PRICE PER FONT \$1 00

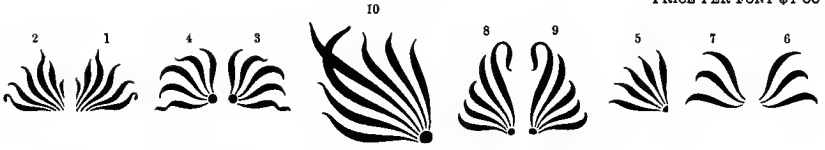

## Shaded Palmetto Ornaments

PRICE PER FONT \$1 00

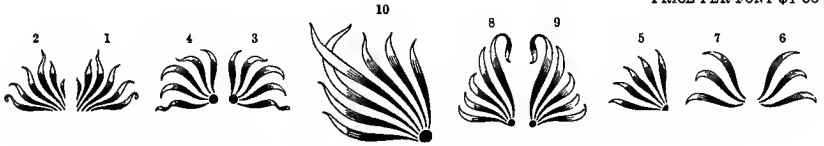

## Contour Palmetto Ornaments

PRICE PER FONT \$1 00

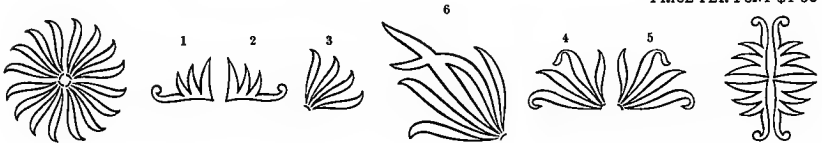

## Central Ornaments No 1

PRICE PER FONT \$1 00



## Central Ornaments No 2

PRICE PER FONT \$1 00



## Central Ornaments No 3

PRICE PER FONT \$1 00



AMERICAN TYPE FOUNDERS COMPANY

# Central Ornaments

## Series No 4

PER FONT \$2 00

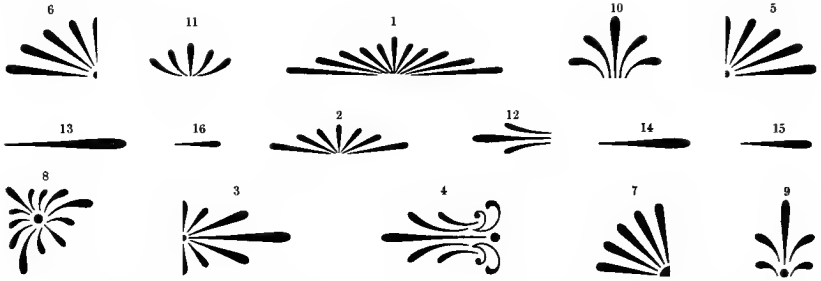

## Series No 5

PER FONT \$2 00

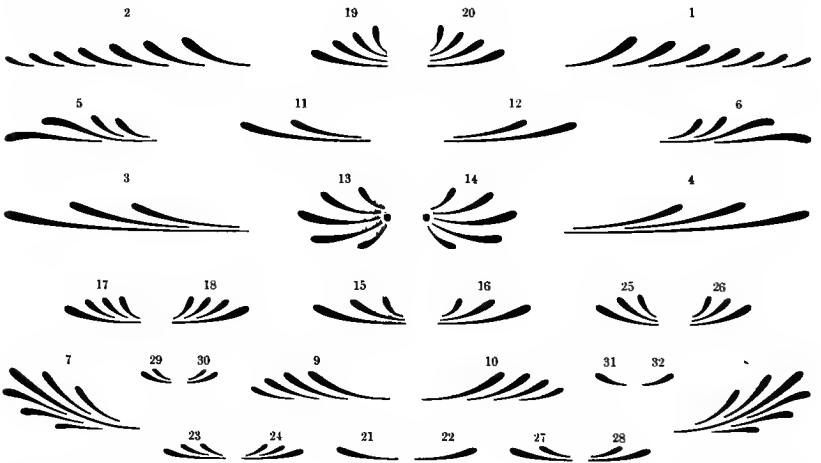

## Series No 6

PER FONT \$2 00

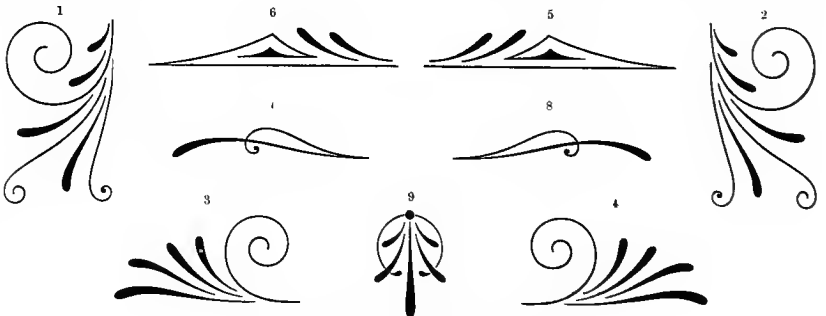

AMERICAN TYPE FOUNDERS COMPANY



# Apple Blossom Ornaments

PRICE PER FONT \$3 00

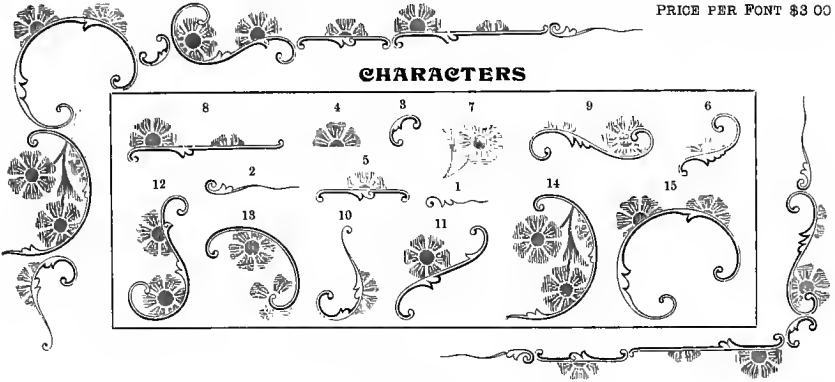

## CHARACTERS

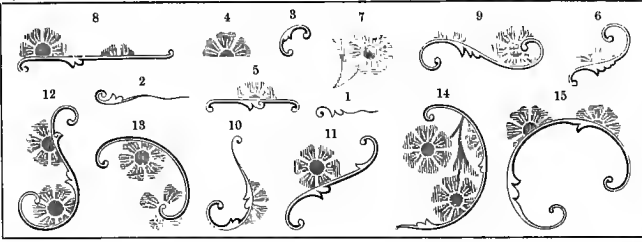

# Electric Ornaments

COMPLETE FONT \$3 50

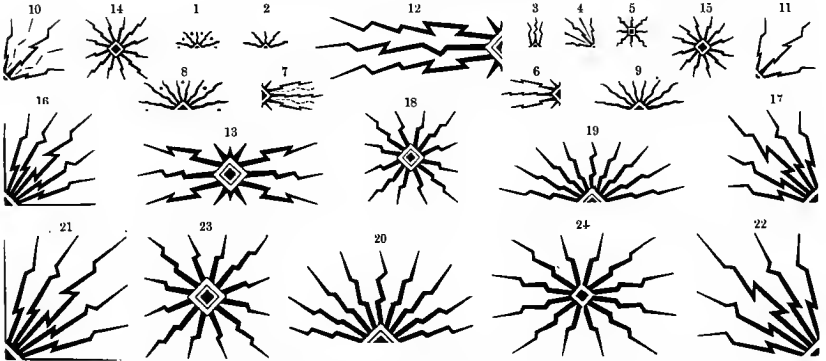

The font contains 140 pieces. 1 and 2, twelve each; 3, eight; 4, 6, 7, 8, 9, 10, 11, 16, 17, 18, 21, 22, 23, four each; 5, thirty-six [six inches]; 12, 13, 19, 20, 24, two each; 14, 15, five each

# Scroll Corner Ornaments

PRICE PER FONT \$3 00

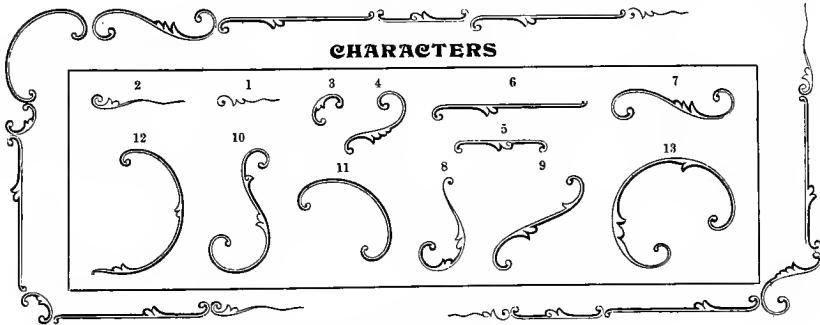

## CHARACTERS

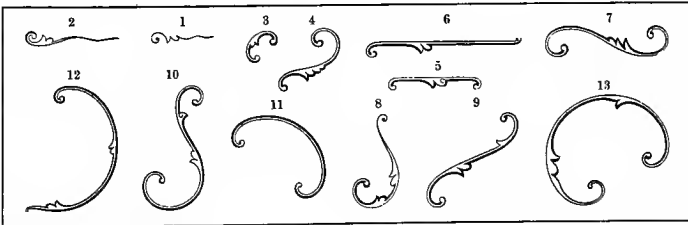

AMERICAN TYPE FOUNDERS COMPANY

## Rococo Border

### CHARACTERS



PRICE PER FONT \$2 50

## Caxton Borders

18 POINT No 240



30 INCHES \$1 50



12 POINT No 239



36 INCHES \$1 50



10 POINT No 238



40 INCHES \$1 50



6 POINT No 237

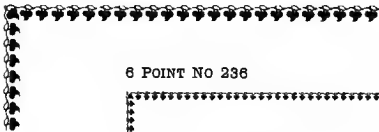

54 INCHES \$1 50

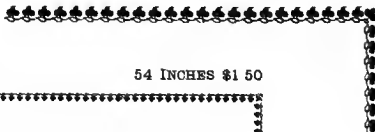

6 POINT No 236

54 INCHES \$1 50



AMERICAN TYPE FOUNDERS COMPANY

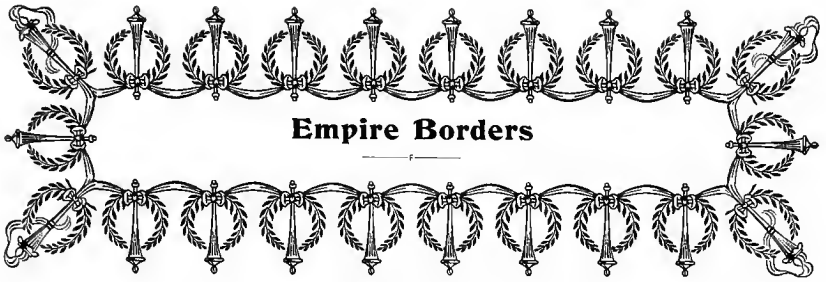

**Empire Borders**

36 POINT NO 1 \$2 50

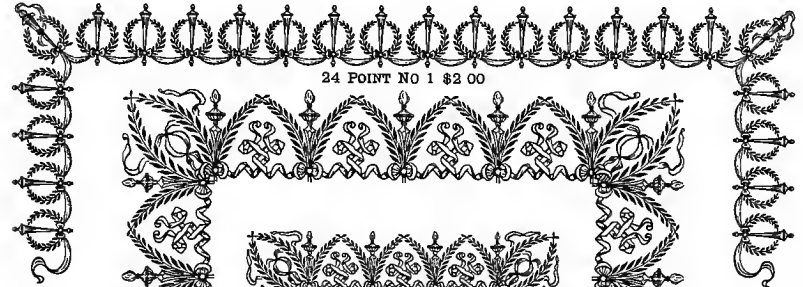

24 POINT NO 1 \$2 00

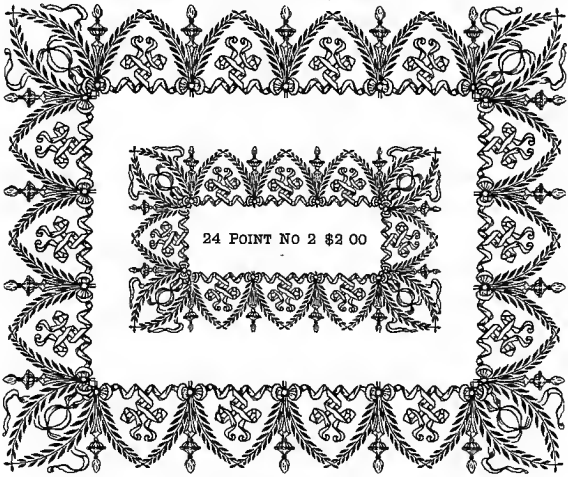

24 POINT NO 2 \$2 00

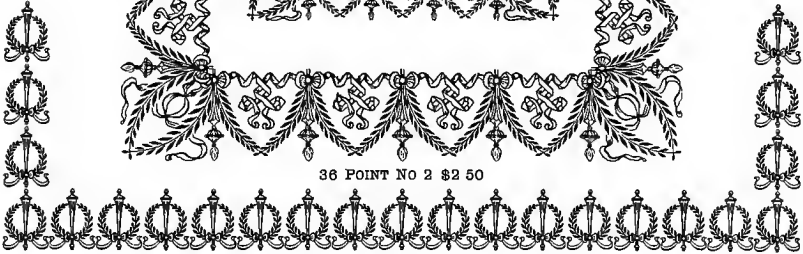

36 POINT NO 2 \$2 50



24 POINT NO 3 \$2 00

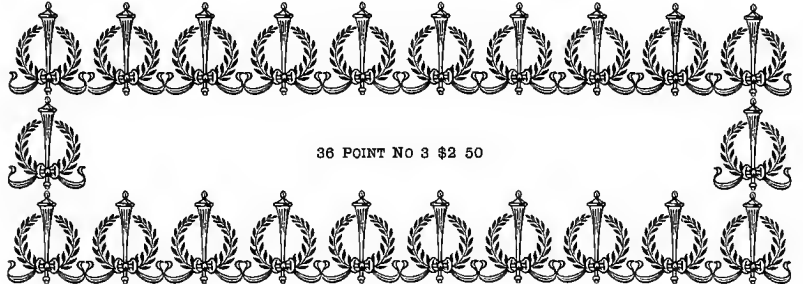

36 POINT NO 3 \$2 50

AMERICAN TYPE FOUNDERS COMPANY

# Laurel Borders

*These Borders register for Colors*

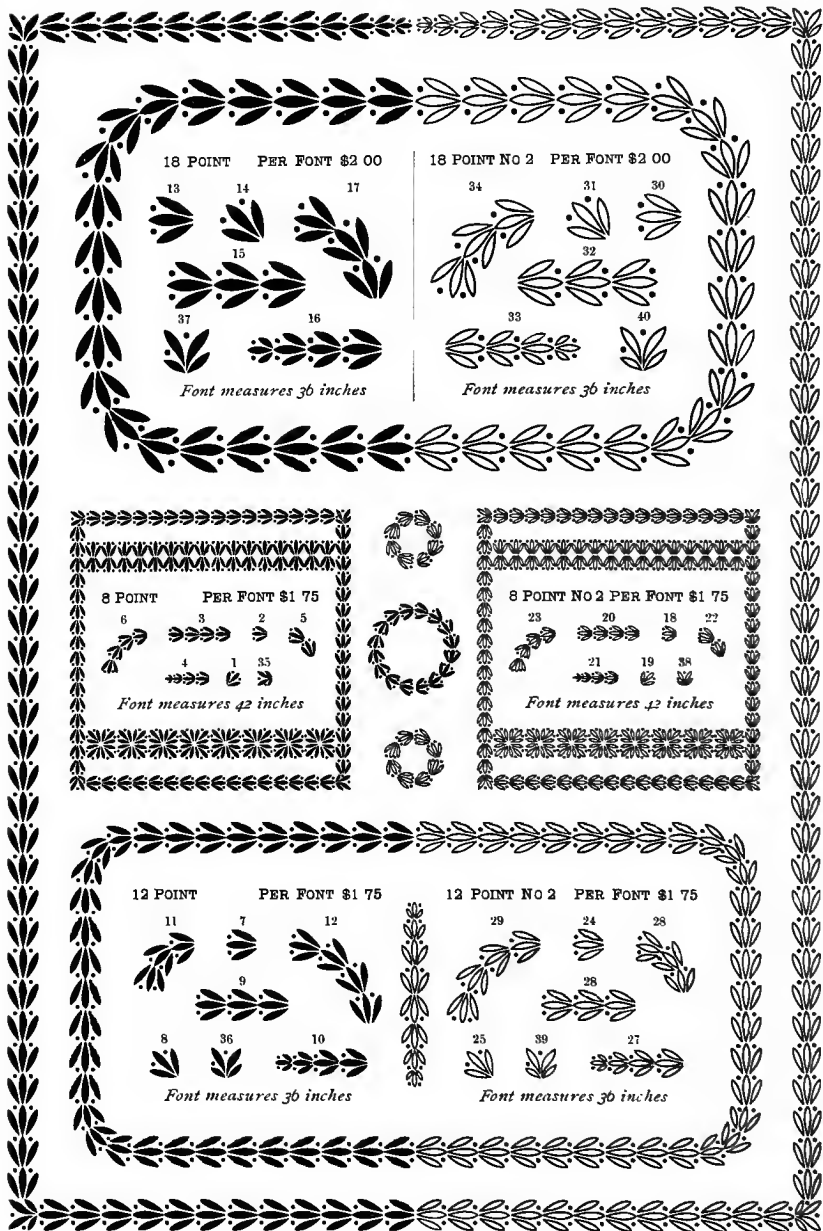

18 POINT PER FONT \$2 00

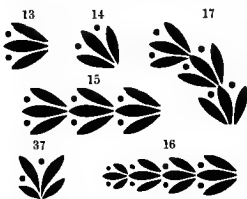

*Font measures 36 inches*

18 POINT NO 2 PER FONT \$2 00

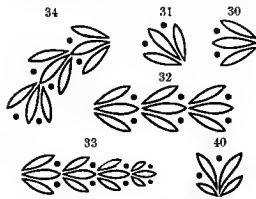

*Font measures 36 inches*

8 POINT PER FONT \$1 75

*Font measures 42 inches*



8 POINT NO 2 PER FONT \$1 75

*Font measures 42 inches*

12 POINT PER FONT \$1 75

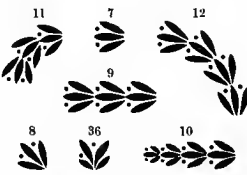

*Font measures 36 inches*

12 POINT NO 2 PER FONT \$1 75

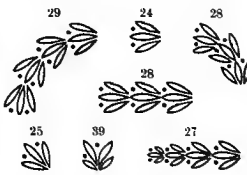

*Font measures 36 inches*

# Laurel Ornaments

— — — — —

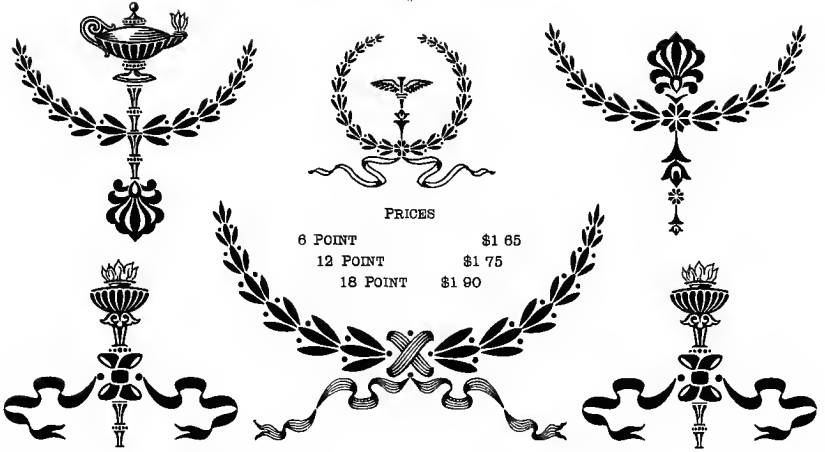

### PRICES

6 POINT	\$1 65
12 POINT	\$1 75
18 POINT	\$1 90



POINT BODIES

THREE SIZES

*These Ornaments are cast in a cored type mould, with as little shoulder as possible on the inside of the wreaths, so that type lines may be set close up. A great variety of designs may be quickly and easily produced with these inexpensive ornaments.*

### CHARACTERS OF 18 POINT LAUREL ORNAMENTS.

*The characters of 6 Point and 12 Point are nearly alike.*

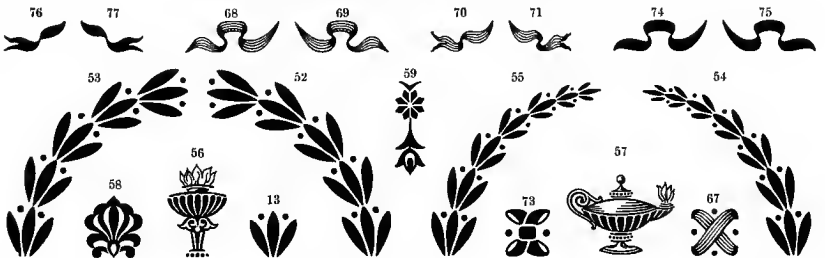

AMERICAN TYPE FOUNDERS COMPANY

# Collins Florets

## GROUP M

Single character, 8 cents

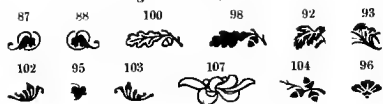

## GROUP N

Single character, 10 cents



## GROUP O

Single character, 10 cents

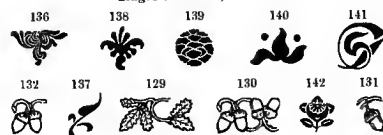

## GROUP P

Each character put up in sets of FOUR, at 35 cents per set  
Single character, 10 cents

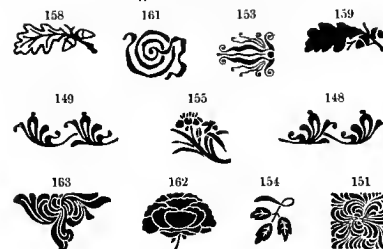

## GROUP R

Each character put up in sets of FOUR, at 50 cents per set



## GROUP Q

Each character put up in sets of FOUR, at 40 cents per set



## GROUP V

Single character, 8 cents

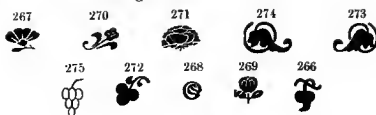

## GROUP X

Single character, 10 cents



## GROUP W

Single character, 10 cents

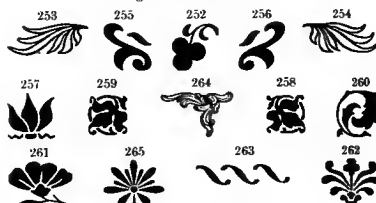

## GROUP Y

Each character put up in sets of FOUR, at 35 cents per set  
Single character, 10 cents

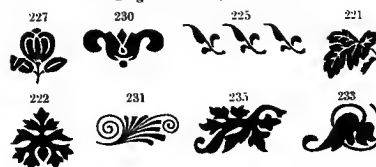

Single character, 15 cents



Single character, 12 cents



AMERICAN TYPE FOUNDERS COMPANY

# Collins Florets

## GROUP B-2 Each character 30 cents



## GROUP S Each character 30 cents



# Collins Borders

24 POINT NO 195

20 INCHES \$1 50



24 POINT NO 196

20 INCHES \$1 50



18 POINT NO 171

30 INCHES \$1 50



18 POINT NO 199

30 INCHES \$1 50



38 POINT NO 197

18 INCHES \$1 50



30 POINT NO 203

20 INCHES \$1 50



18 POINT NO 223

30 INCHES \$1 50



38 POINT NO 172

18 INCHES \$1 50



18 POINT NO 173

30 INCHES \$1 50



18 POINT NO 200

30 INCHES \$1 50



## Collins Bands

12 POINT NO 175                      36 INCHES \$1 50



12 POINT NO 174                      36 INCHES \$1 50



12 POINT NO 202                      36 INCHES \$1 50



12 POINT NO 178                      36 INCHES \$1 50



18 POINT NO 218                      30 INCHES \$1 50



18 POINT NO 181                      30 INCHES \$1 50



18 POINT NO 182                      30 INCHES \$1 50



18 POINT NO 220                      30 INCHES \$1 50



18 POINT NO 218                      30 INCHES \$1 50



18 POINT NO 178                      30 INCHES \$1 50



24 POINT NO 188                      20 INCHES \$1 50



24 POINT NO 185                      20 INCHES \$1 50



18 POINT NO 214                      30 INCHES \$1 50



24 POINT NO 189                      20 INCHES \$1 50



24 POINT NO 209

20 INCHES \$1 50



30 POINT NO 192

20 INCHES \$1 50



42 POINT NO 193

12 INCHES \$1 50



42 POINT NO 204

12 INCHES \$1 50



AMERICAN TYPE FOUNDERS COMPANY



# Elzevir Borders and Bands

6 POINT NO 100 54 INCHES \$1 50



20 POINT NO 110 30 INCHES \$1 50



20 POINT NO 108 30 INCHES \$1 50



28 POINT NO 118

18 INCHES \$1 50



28 POINT NO 120

18 INCHES \$1 50



14 POINT NO 104

38 INCHES \$1 50



14 POINT NO 108

24 INCHES \$1 50



20 POINT NO 109

30 INCHES \$1 50



# Elzevir Florets

## GROUP A

PER FONT \$1 50

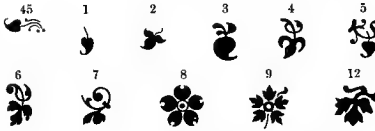

## GROUP B

PER FONT \$2 00

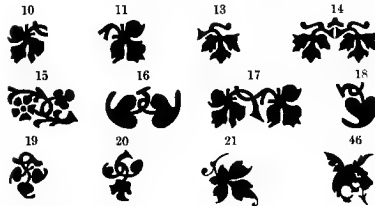

## GROUP D

PER FONT \$2 00

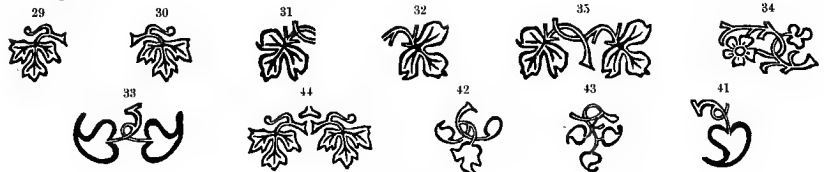

AMERICAN TYPE FOUNDERS COMPANY

# Barta Borders

*Patent applied for*

30 POINT NO 243

20 INCHES \$1 50

30 POINT NO 251

20 INCHES \$1 50

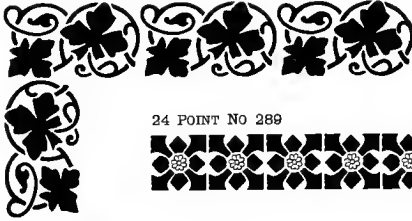

24 POINT NO 289

20 INCHES \$1 50



18 POINT NO 241 30 INCHES \$1 50

18 POINT NO 250

30 INCHES \$1 50



24 POINT NO 284

20 INCHES \$1 50



18 POINT NO 291

30 INCHES \$1 50



24 POINT NO 242

20 INCHES \$1 50



24 POINT NO 281

20 INCHES \$1 50

18 POINT NO 248 30 INCHES \$1 50



18 POINT NO 247

30 INCHES \$1 50



18 POINT NO 246

30 INCHES \$1 50



12 POINT NO 282

36 INCHES \$1 50



36 POINT NO 287 18 INCHES \$1 50

36 POINT NO 288 18 INCHES \$1 50



AMERICAN TYPE FOUNDERS COMPANY

# Florentine Borders

6 POINT NO 224 54 INCHES \$1 50

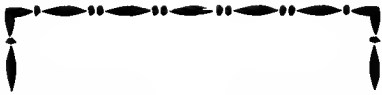

6 POINT NO 226 50 INCHES \$1 50



6 POINT NO 225 54 INCHES \$1 50

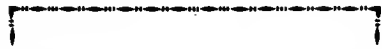

6 POINT NO 165 54 INCHES \$1 50

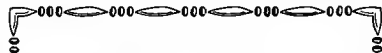

6 POINT NO 161 50 INCHES \$1 50



6 POINT NO 227 50 INCHES \$1 50

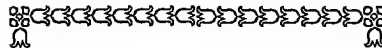

12 POINT NO 148 36 INCHES \$1 50



6 POINT NO 160 50 INCHES \$1 50



12 POINT NO 159 36 INCHES \$1 50



16 POINT NO 158 30 INCHES \$1 50



12 POINT NO 164 36 INCHES \$1 50



18 POINT NO 163 30 INCHES \$1 50



24 POINT NO 162 20 INCHES \$1 50



6 POINT NO 170 50 INCHES \$1 50

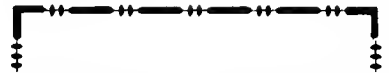

6 POINT NO 169 54 INCHES \$1 50

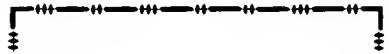

6 POINT NO 168 50 INCHES \$1 50

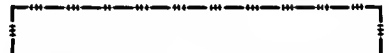

6 POINT NO 188 50 INCHES \$1 50



6 POINT NO 167 54 INCHES \$1 50

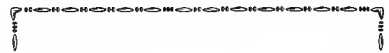

6 POINT NO 156 50 INCHES \$1 50



6 POINT NO 152 50 INCHES \$1 50



12 POINT NO 155 36 INCHES \$1 50



16 POINT NO 154 30 INCHES \$1 50



12 POINT NO 149 36 INCHES \$1 50



18 POINT NO 148 30 INCHES \$1 50



12 POINT NO 140 36 INCHES \$1 50



16 POINT NO 139 30 INCHES \$1 50



AMERICAN TYPE FOUNDERS COMPANY

# Contour Bands and Borders

Patent applied for

24 POINT NO 280

20 INCHES \$1 50

24 POINT NO 259

20 INCHES \$1 50



24 POINT NO 268

20 INCHES \$1 50



42 POINT NO 286

12 INCHES \$1 50



18 POINT NO 275

30 INCHES \$1 50

12 POINT NO 274

38 INCHES \$1 50



8 POINT NO 272

54 INCHES \$1 50

10 POINT NO 273

40 INCHES \$1 50

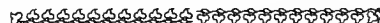

Fonts of Borders Nos. 272, 273, 274 and 275 include two styles of corners

18 POINT NO 258

30 INCHES \$1 50



18 POINT NO 285

30 INCHES \$1 50



18 POINT NO 289 30 INCHES \$1 50

24 POINT NO 288

20 INCHES \$1 50



The Borders on this page and on page 385 register for colors with the following solid Borders :

		PAGE			PAGE
Contour Border No. 260	with Collins Border No. 195	379	Contour Border No. 268	with Florentine Border No. 162	383
" " " 259	" " " 196	379	" " " 262	" Collins Border No. 197	379
" " " 265	" Florentine Border No. 234	—	" " " 268	" " " 172	379
" " " 296	" Collins Band No. 193	380	" " " 257	" " " 198	—
" " " 275	" Caxton Border No. 240	374	" " " 297	" Collins Band No. 204	380
" " " 274	" " " 239	374	" " " 267	" Florentine Border No. 158	383
" " " 273	" " " 237	374	" " " 270	" " " 220	—
" " " 272	" " " 237	374	" " " 271	" " " 230	—
" " " 258	" Collins Band No. 221	—	" " " 295	" Collins Band No. 205	—
" " " 265	" Florentine Border No. 233	—	" " " 261	" Collins Border No. 173	379
" " " 269	" " " 103	383	" " " 263	" " " 203	379

AMERICAN TYPE FOUNDERS COMPANY

# Contour Bands and Borders

Patent applied for

36 POINT NO 262

16 INCHES \$1 50

36 POINT NO 296

18 INCHES \$1 50



18 POINT NO 257

30 INCHES \$1 50

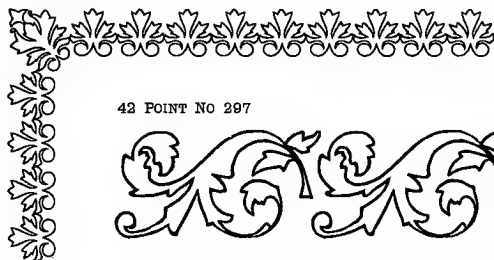

42 POINT NO 297

12 INCHES \$1 50



16 POINT NO 287

30 INCHES \$1 50

16 POINT NO 264

30 INCHES \$1 50

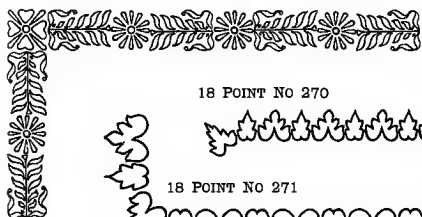

18 POINT NO 270

30 INCHES \$1 50

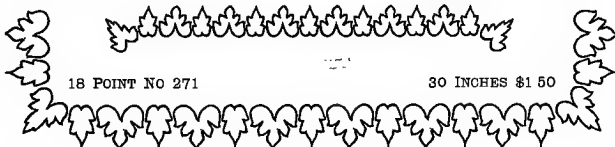

18 POINT NO 271

30 INCHES \$1 50



48 POINT NO 295

12 INCHES \$1 50

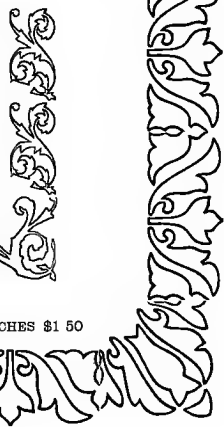
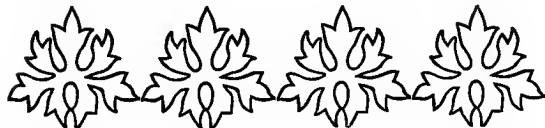

16 POINT NO 261

30 INCHES \$1 50



30 POINT NO 263

20 INCHES \$1 50



AMERICAN TYPE FOUNDERS COMPANY

# Art Borders

*These Borders are made to register for two colors*

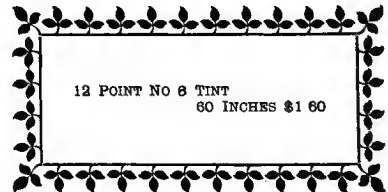
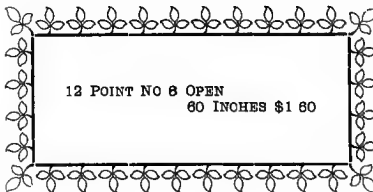
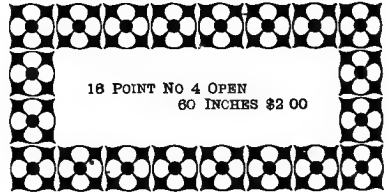
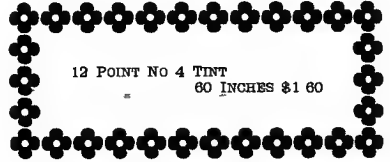
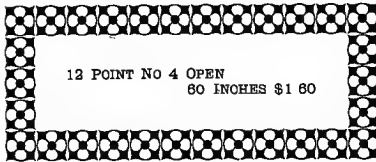
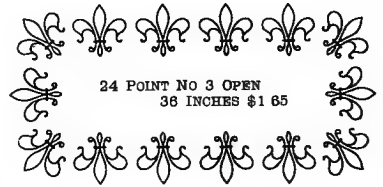
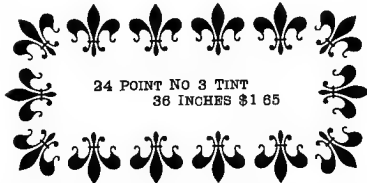
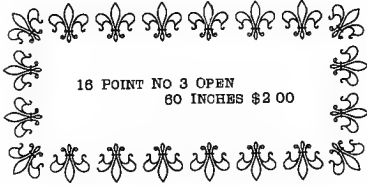
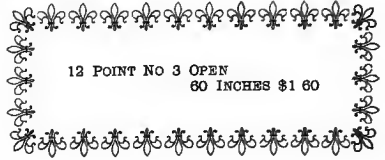
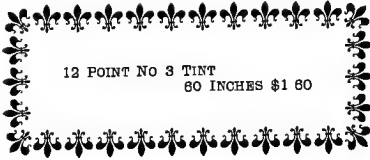

AMERICAN TYPE FOUNDERS COMPANY

# Art Borders

*These Borders are made to register for two colors*

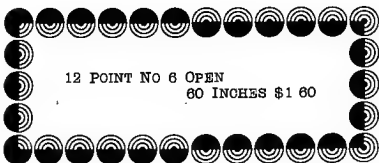
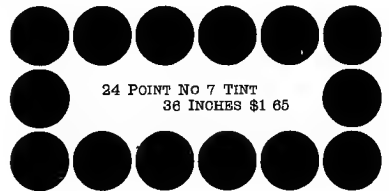
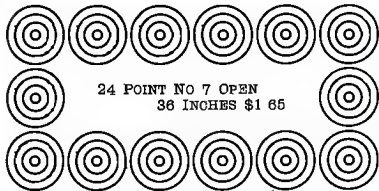
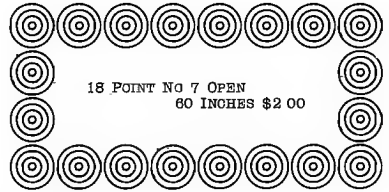
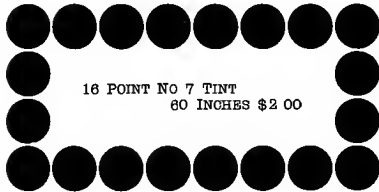
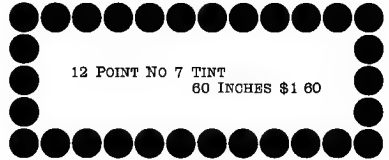
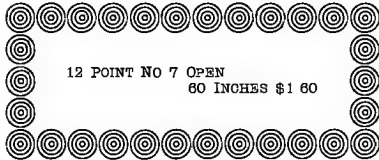
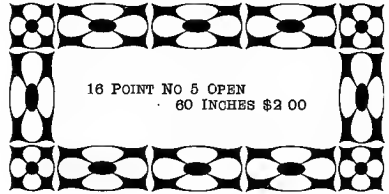
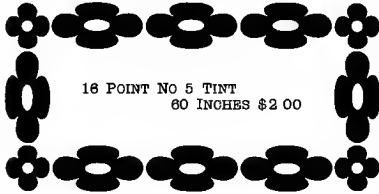
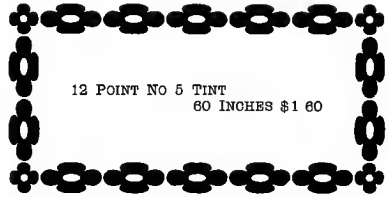
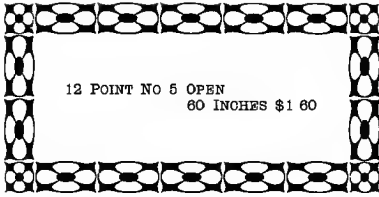

AMERICAN TYPE FOUNDERS COMPANY

# Art Borders

*Art Borders Nos. 6, 9 and 10, all sizes, are made to register for two colors*

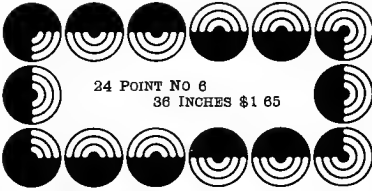

24 POINT NO 6  
36 INCHES \$1 65

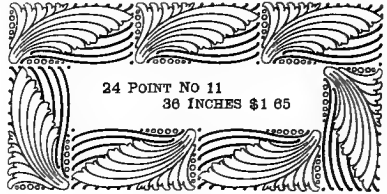

24 POINT NO 11  
36 INCHES \$1 65

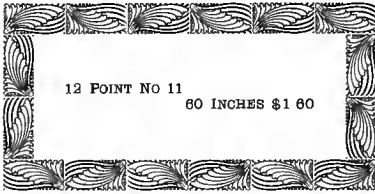

12 POINT NO 11  
60 INCHES \$1 60

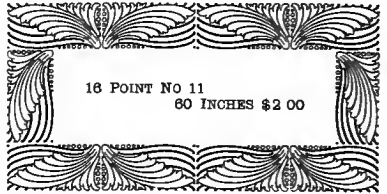

16 POINT NO 11  
60 INCHES \$2 00

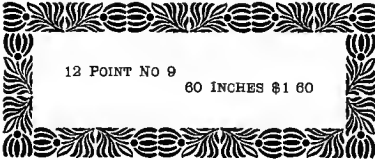

12 POINT NO 9  
60 INCHES \$1 60

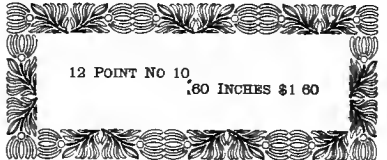

12 POINT NO 10  
60 INCHES \$1 60

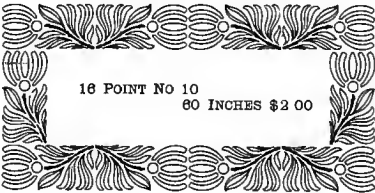

16 POINT NO 10  
60 INCHES \$2 00

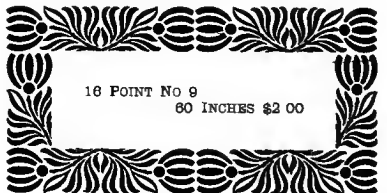

16 POINT NO 9  
60 INCHES \$2 00

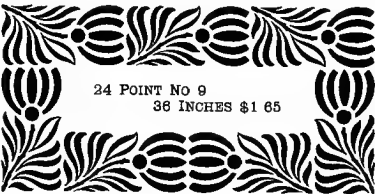

24 POINT NO 9  
36 INCHES \$1 65

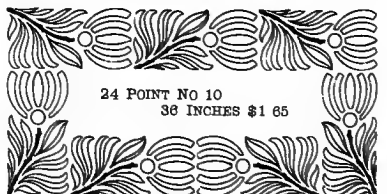

24 POINT NO 10  
36 INCHES \$1 65

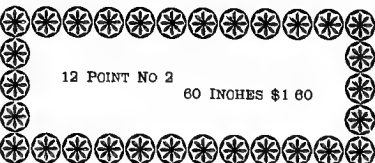

12 POINT NO 2  
60 INCHES \$1 60

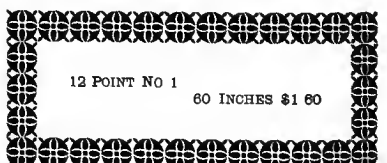

12 POINT NO 1  
60 INCHES \$1 60

AMERICAN TYPE FOUNDERS COMPANY



# Art Borders

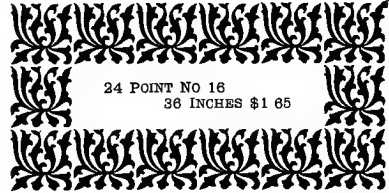
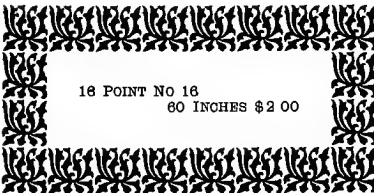
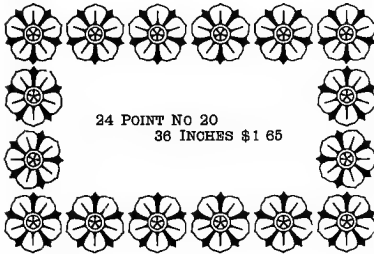
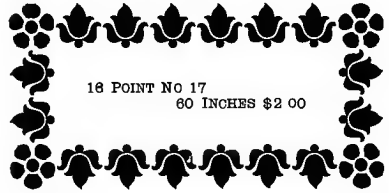
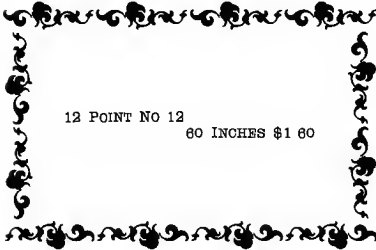
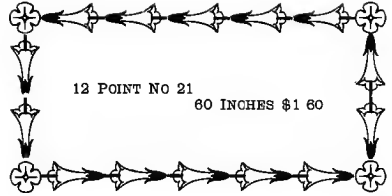
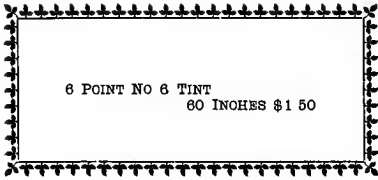

AMERICAN TYPE FOUNDERS COMPANY

# Art Borders

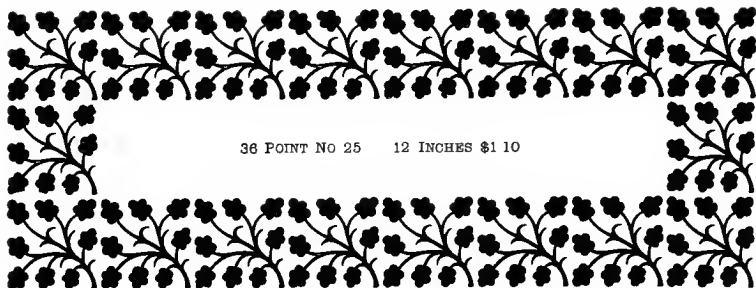

36 POINT NO 25 12 INCHES \$1 10

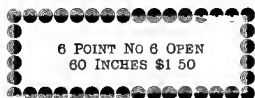

6 POINT NO 6 OPEN  
60 INCHES \$1 50

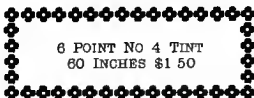

6 POINT NO 4 TINT  
60 INCHES \$1 50

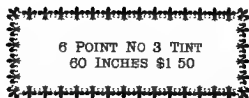

6 POINT NO 3 TINT  
60 INCHES \$1 50

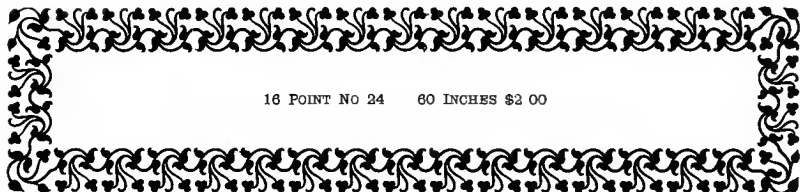

16 POINT NO 24 60 INCHES \$2 00



24 POINT NO 24  
36 INCHES \$1 65



24 POINT NO 25  
36 INCHES \$1 65

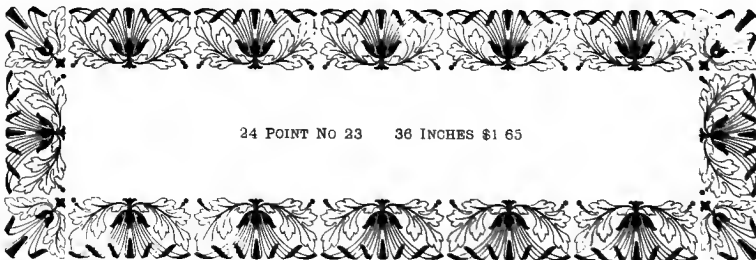

24 POINT NO 23 36 INCHES \$1 65

AMERICAN TYPE FOUNDERS COMPANY

# Newspaper Borders

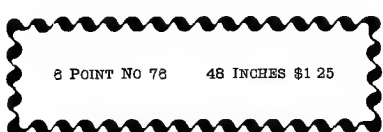
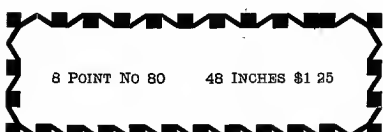
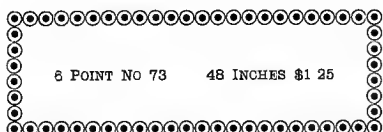
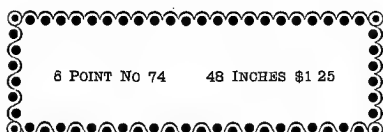
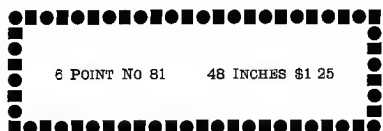
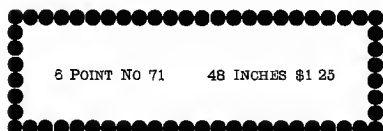
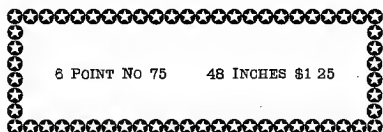
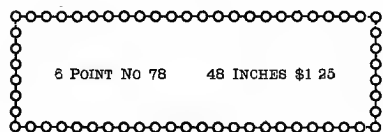
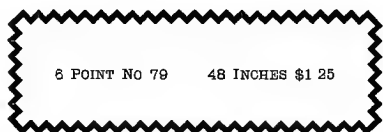
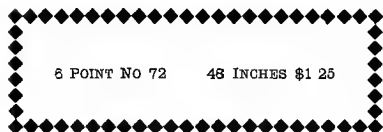
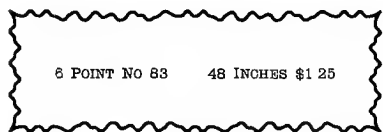
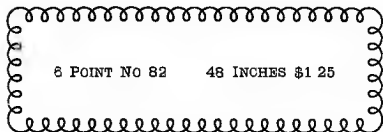
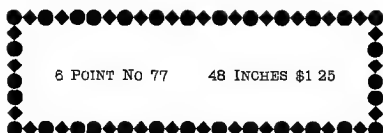
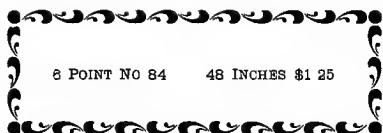

AMERICAN TYPE FOUNDERS COMPANY

# Newspaper Borders

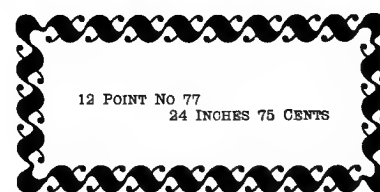
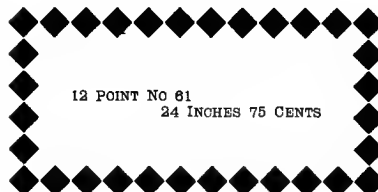
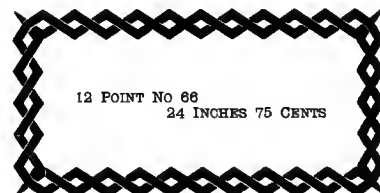
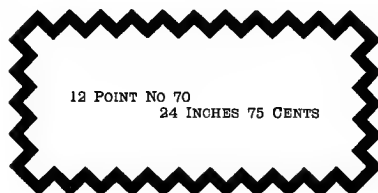
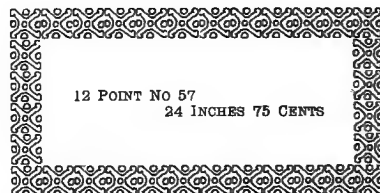
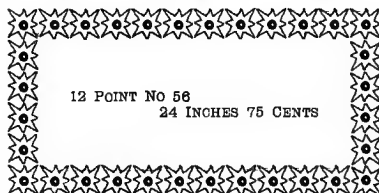
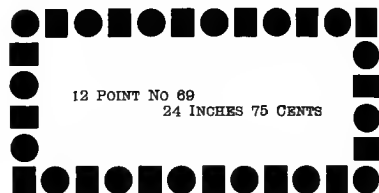
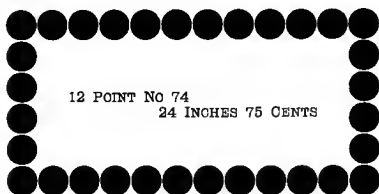
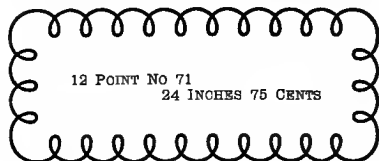
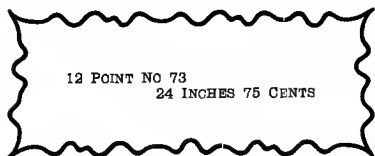
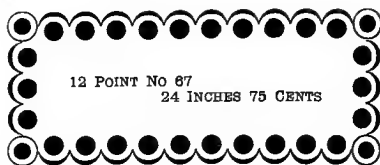
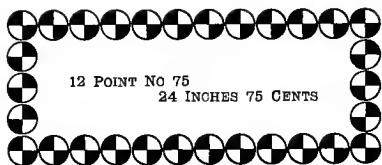

AMERICAN TYPE FOUNDERS COMPANY

# Newspaper Borders

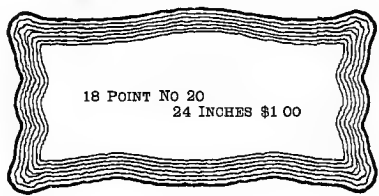
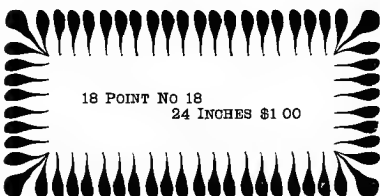
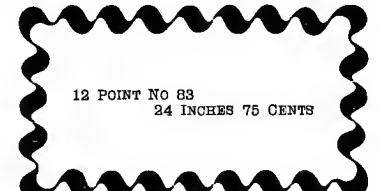
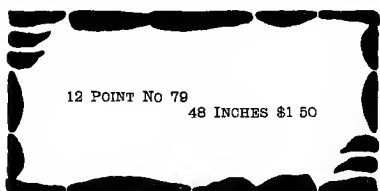
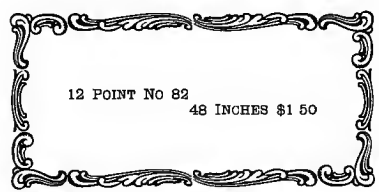
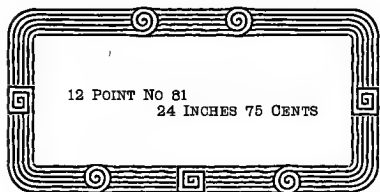
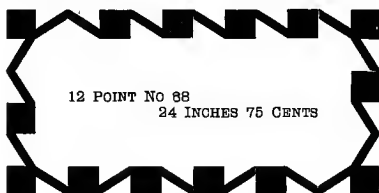
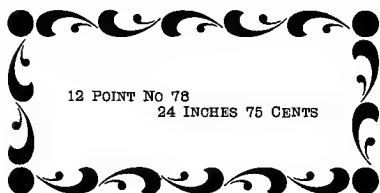
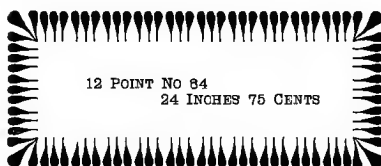
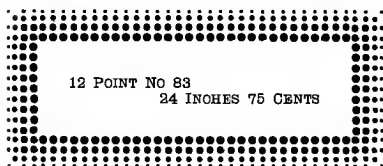
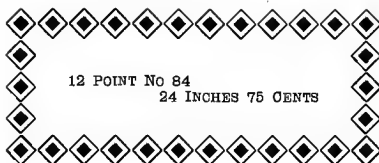
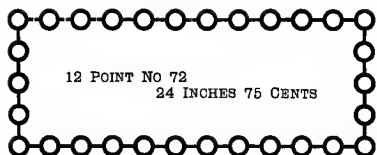

AMERICAN TYPE FOUNDERS COMPANY

# Newspaper Borders

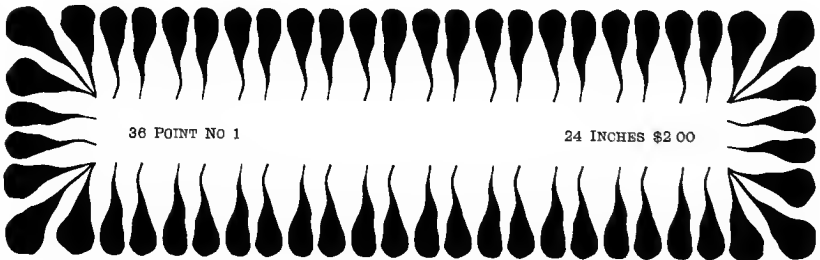
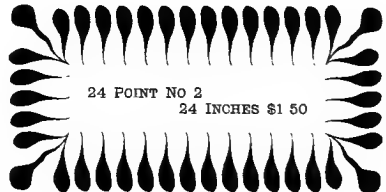
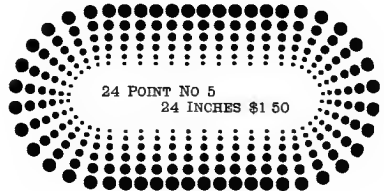
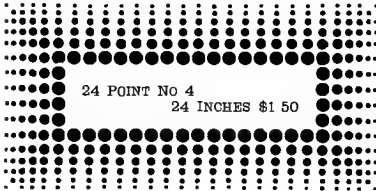
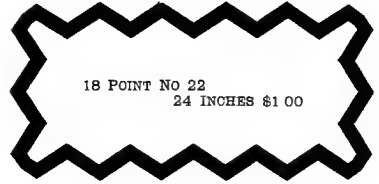
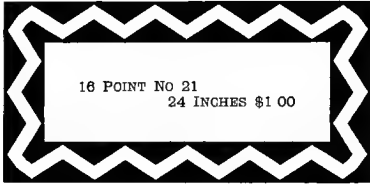
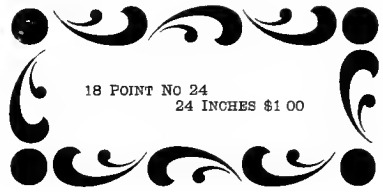
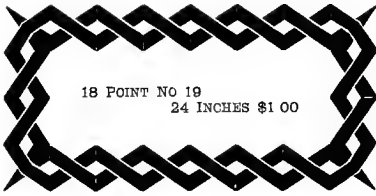

AMERICAN TYPE FOUNDERS COMPANY

## Newspaper Borders

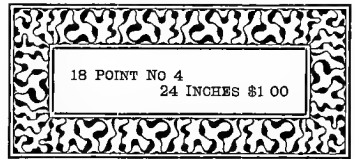
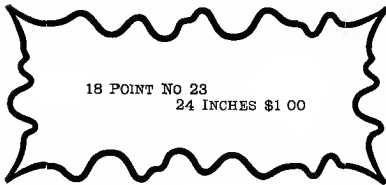
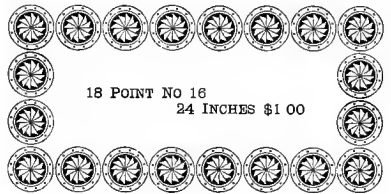
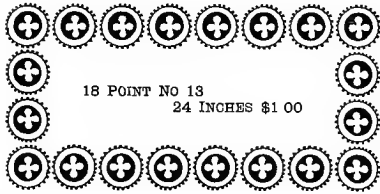
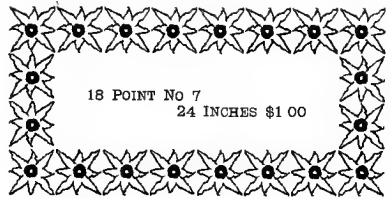
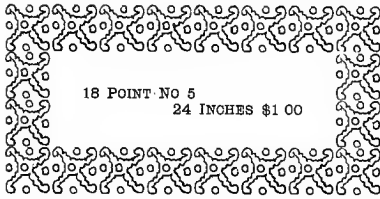

## Eighteen Point Borders

PER FOOT. \$3 00



PER FOOT. 50 CENTS

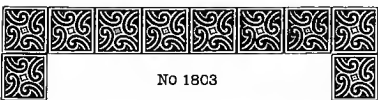
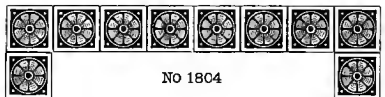

AMERICAN TYPE FOUNDERS COMPANY

## Twelve Point Borders

PER FOOT \$2 50

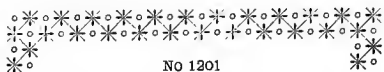

PER FOOT 40 CENTS

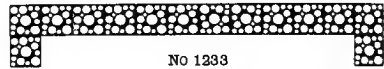

## Twenty-Four Point Borders

PER FOOT \$3 50

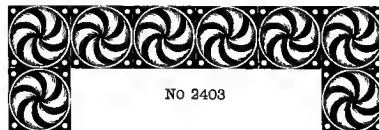
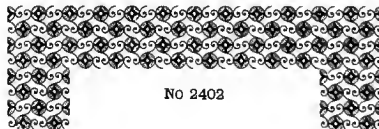
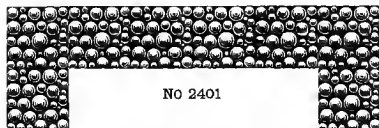

PER FOOT 60 CENTS

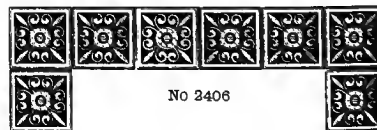
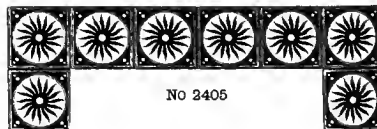
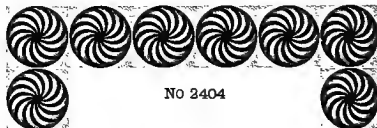

AMERICAN TYPE FOUNDERS COMPANY



# Flame Borders

*Each size is furnished with  
Round and Square Corners*

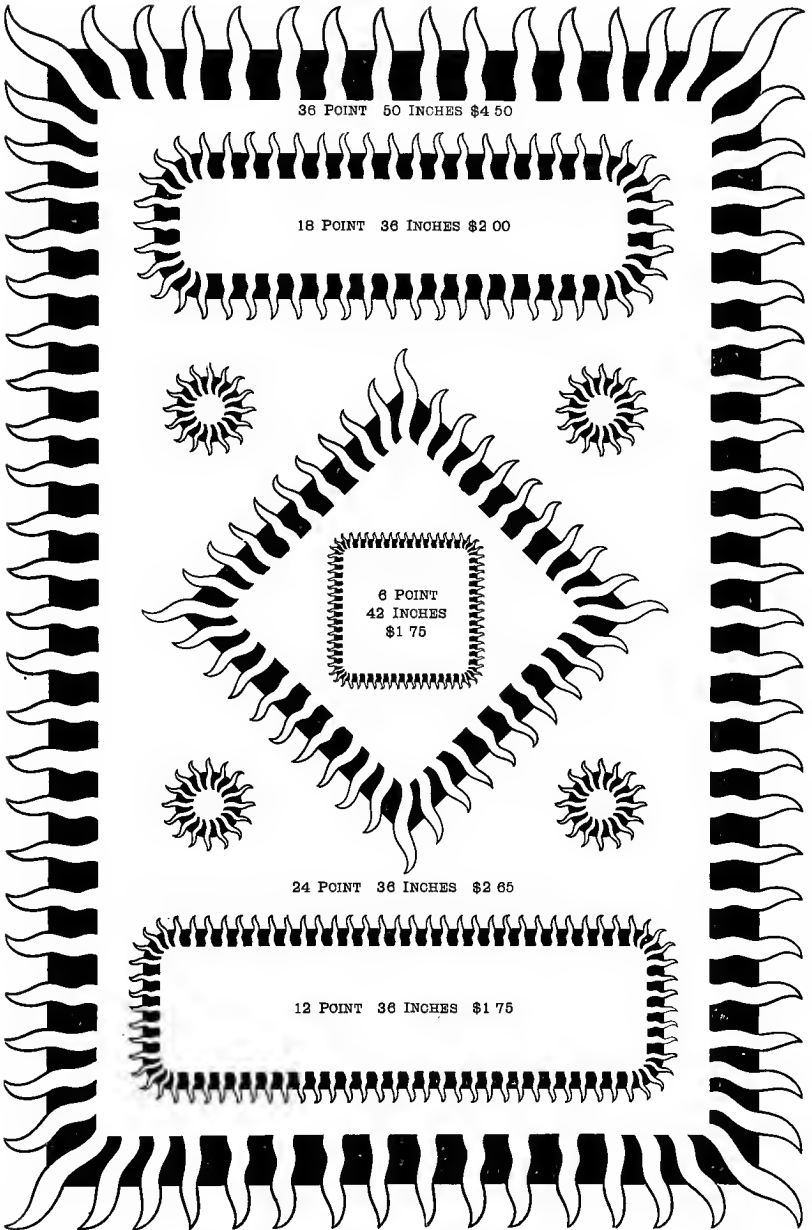

36 POINT 50 INCHES \$4 50

18 POINT 36 INCHES \$2 00

6 POINT  
42 INCHES  
\$1 75

24 POINT 36 INCHES \$2 65

12 POINT 36 INCHES \$1 75

AMERICAN TYPE FOUNDERS COMPANY

# Half Nonpareil Borders

COMPLETE FONT \$2 25 10 FEET LONG

HALF FONT \$1 30 5 FEET LONG

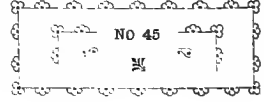
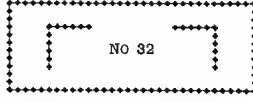
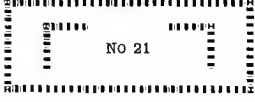
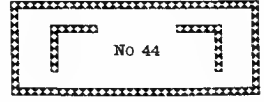
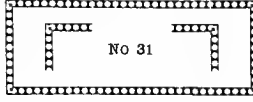
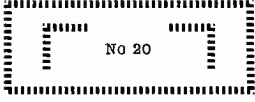
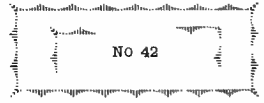
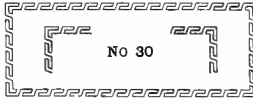
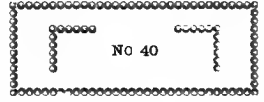
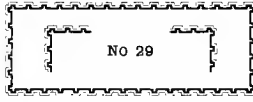
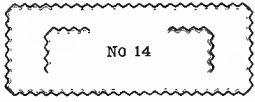
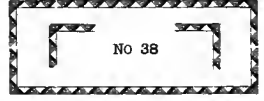
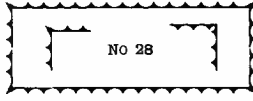
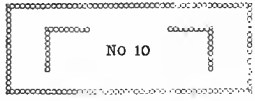
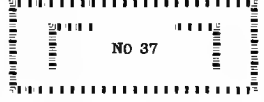
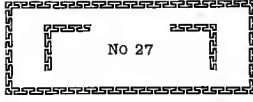
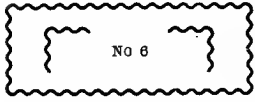
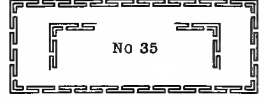
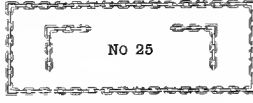
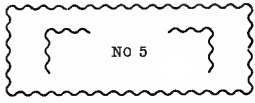
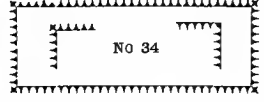
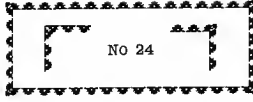
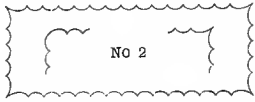
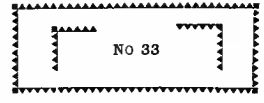

AMERICAN TYPE FOUNDERS COMPANY

# Barth Geometrical Borders

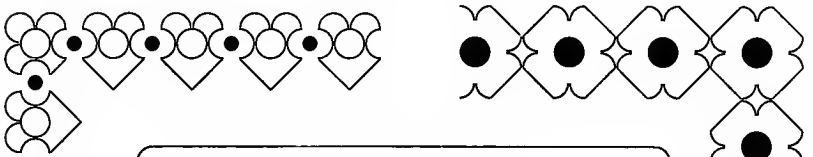
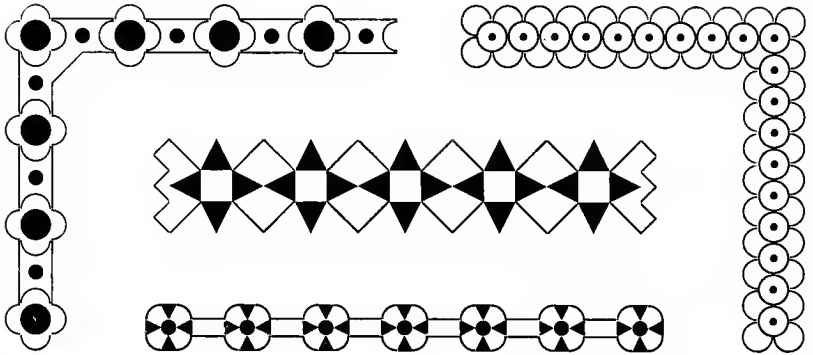

CHARACTERS											
1	2	3	4	5	6	7	8	9	10	11	12
PER FONT \$3 00											

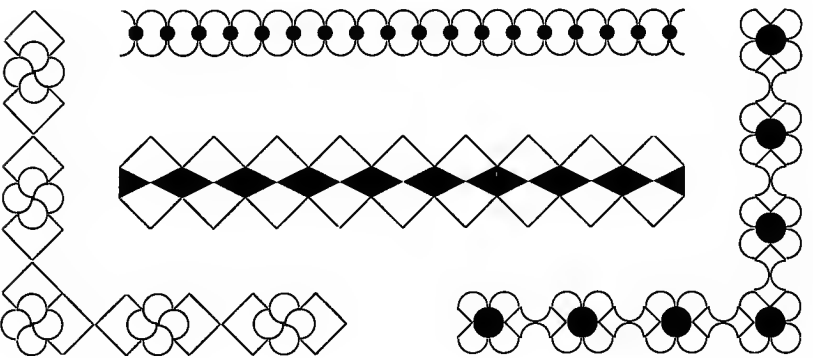
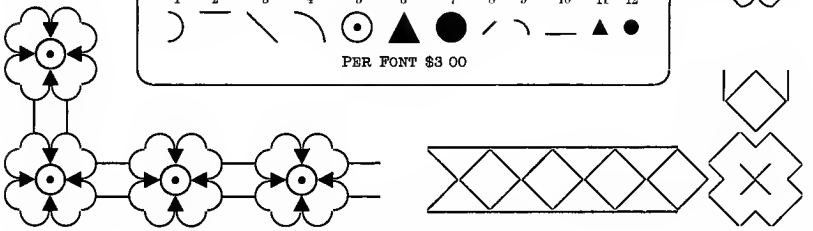

AMERICAN TYPE FOUNDERS COMPANY

# Combination Border

PATENTED

SERIES 98

## CHARACTERS

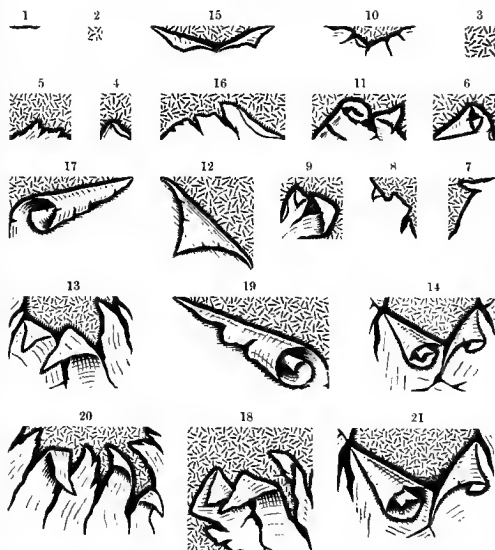

PRICE PER FONT \$6 00

## FIRST SECTION

AMERICAN TYPE FOUNDERS COMPANY

# Combination Border

PATENTED

SERIES 98

## CHARACTERS

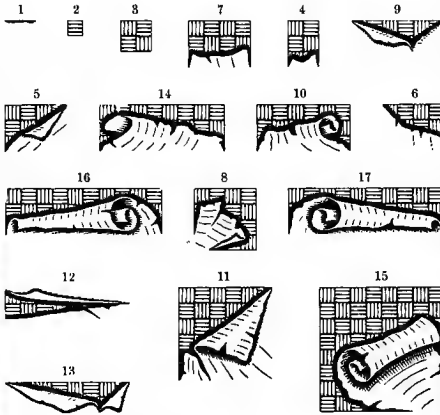

PRICE PER FONT \$5 00

## THIRD SECTION

AMERICAN TYPE FOUNDERS COMPANY

# Combination Border

PATENTED

SERIES 97

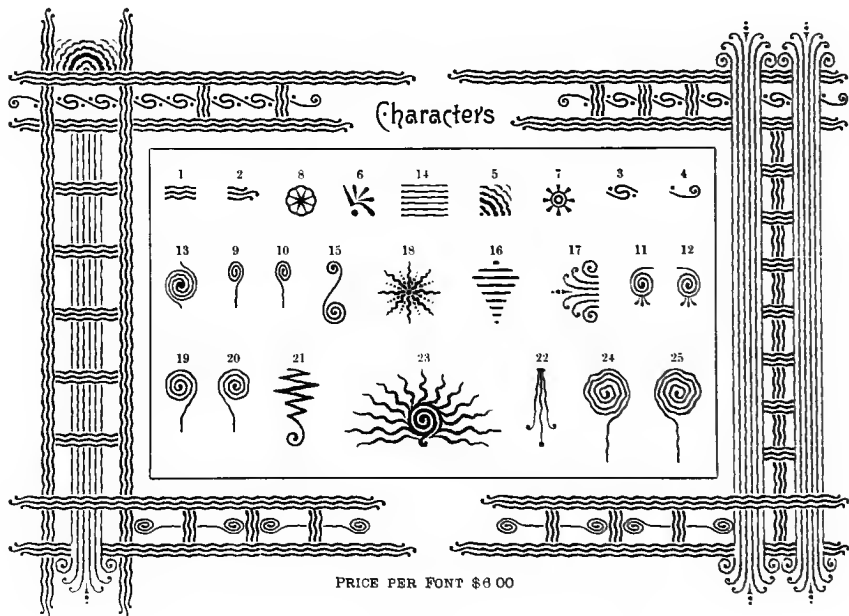
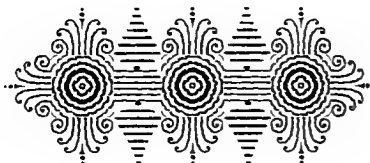
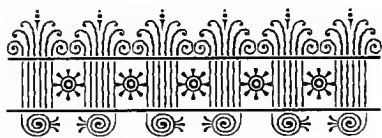
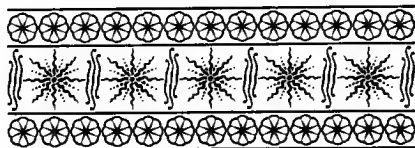
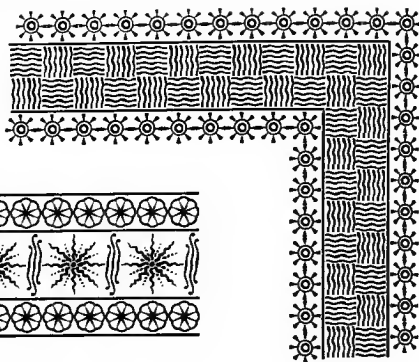
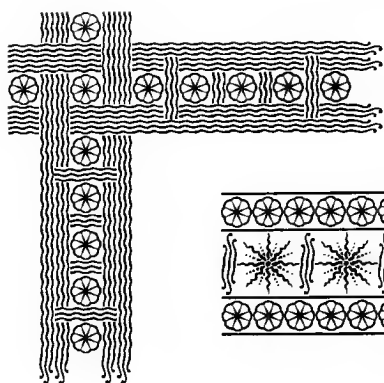

PRICE PER FONT \$6 00

AMERICAN TYPE FOUNDERS COMPANY

# Combination Ornaments Series K

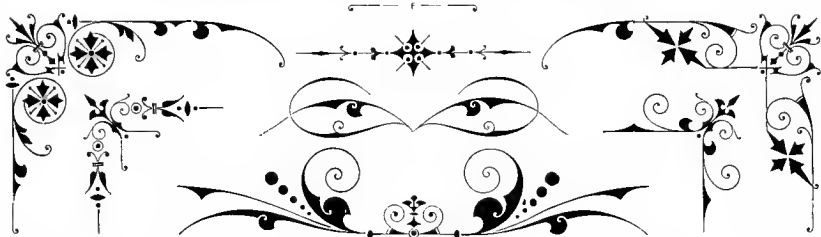

## CHARACTERS

PRICE PER POINT \$4 50

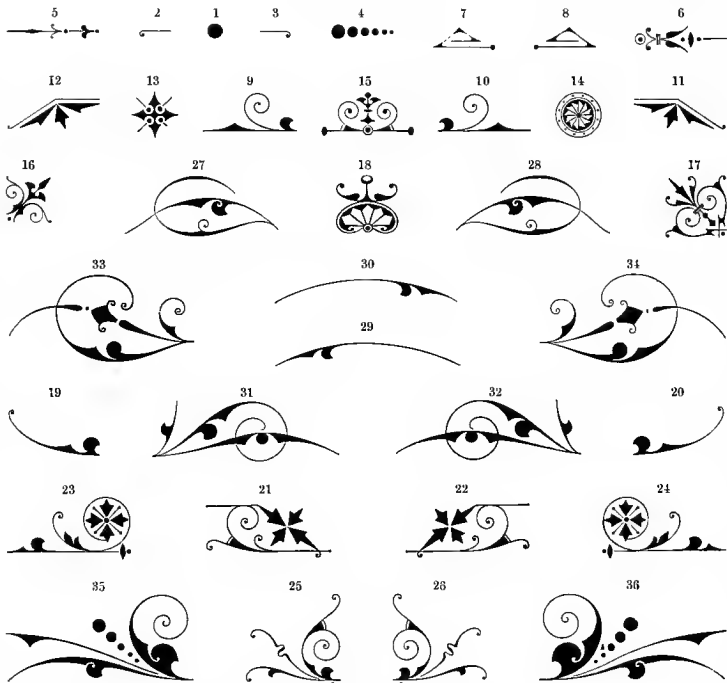

AMERICAN TYPE FOUNDERS COMPANY

# Happy Thoughts

## GROUP F

Each character put up in sets of four at 40 cents per set

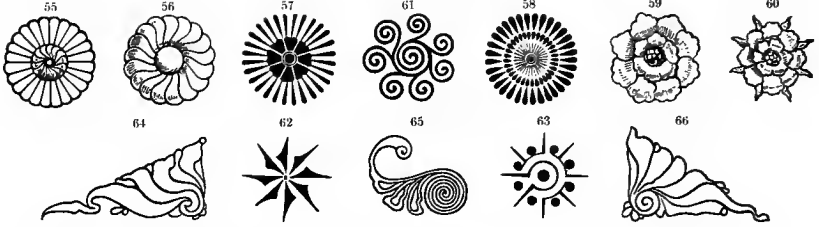

## GROUP K

Each character put up in sets of four at 50c. per set

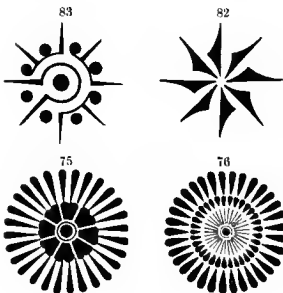
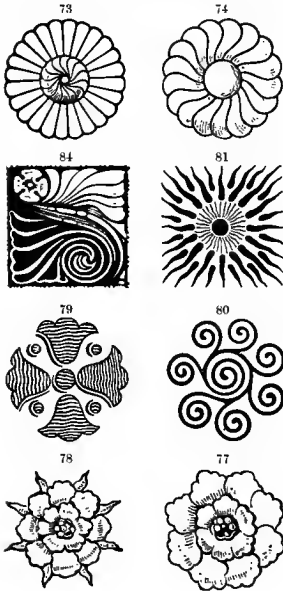

## GROUP G

Each character 40 cents singly



## GROUP E

Each character 35 cents singly

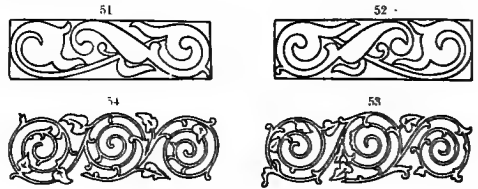

## GROUP L

Each character put up in sets of four at 40 cents per set

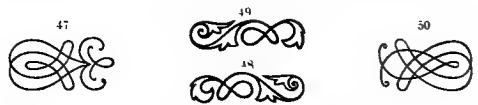

## GROUP H

Each character put up in sets of four at 50 cents per set

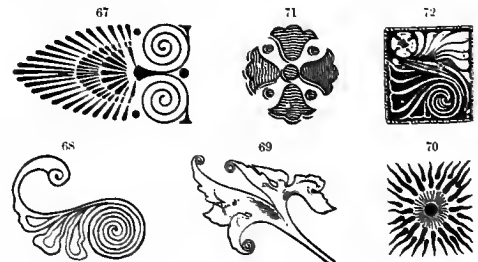

AMERICAN TYPE FOUNDERS COMPANY



# Christmas Ornaments

All characters except 280A put up in sets of four at 50 cents per set

283A. 15 cts. 287A. 15c. 288A. 15c. 286A. 15c. 280A. 40 cts. 281A. 15 cts. 277A. 15 cts. 279A. 15 cts.



# Mural Ornaments

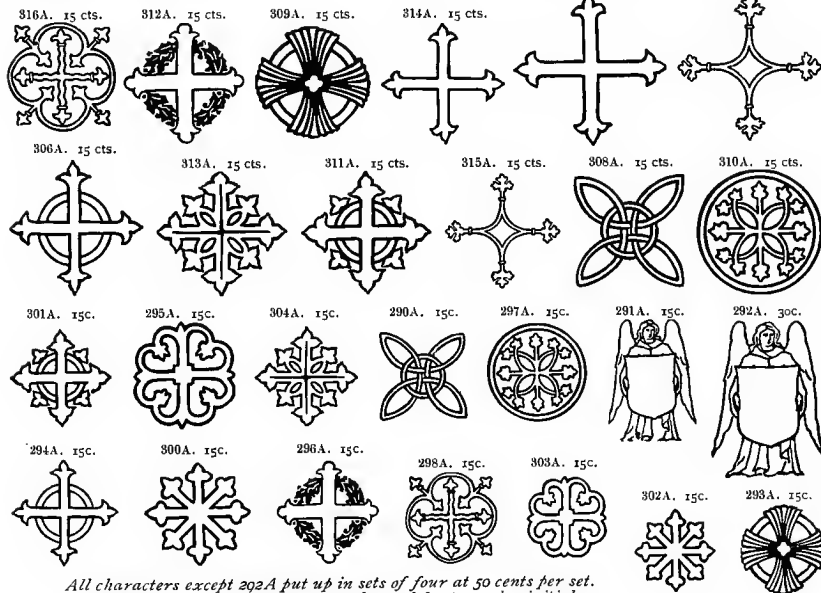

All characters except 292A put up in sets of four at 50 cents per set. Characters Nos. 291A and 292A may be used for two-color initials.

# Margin Ornaments

SERIES NO 1 PER FONT \$1 25  
SERIES NO 2 PER FONT \$1 00

## Series 1



## Series 2



AMERICAN TYPE FOUNDERS COMPANY

# Laurel Wreaths

Prices are *N*

NO 8 \$1 00

MORTISED

NO 17 \$1 00



NO. 4  
50 CTS



NO 13  
50 CTS

NO 11 30 CTS.

NO. 9 \$1 25

NO 2 30 CTS.



NO 14 75 CTS



NO 10 20 CTS.

NO 1 20 CTS.



NO. 12 50 CTS.

NO 3 50 CTS.



SOLID METAL ELECTROTYPES

AMERICAN TYPE FOUNDERS COMPANY

## Slocum Seals

PER FONT \$1 50

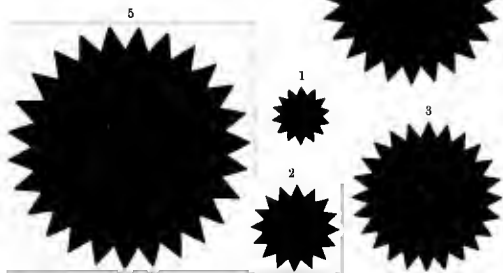

## Ink Spots

PER FONT \$1 25

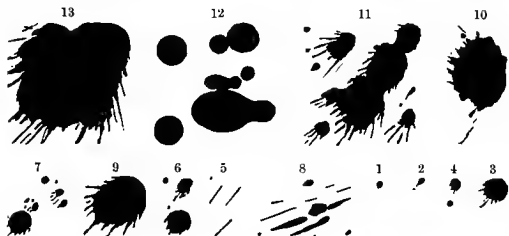

## Engraving Blanks

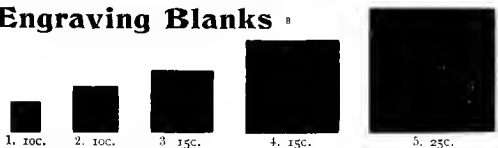

## Insects

PER FONT \$1 25

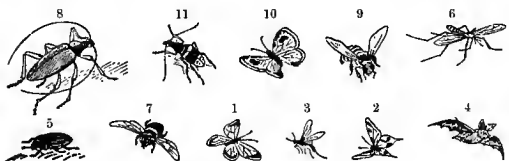

## Footprints

PER FONT \$1 00



## Bowlers

PER FONT \$1 75

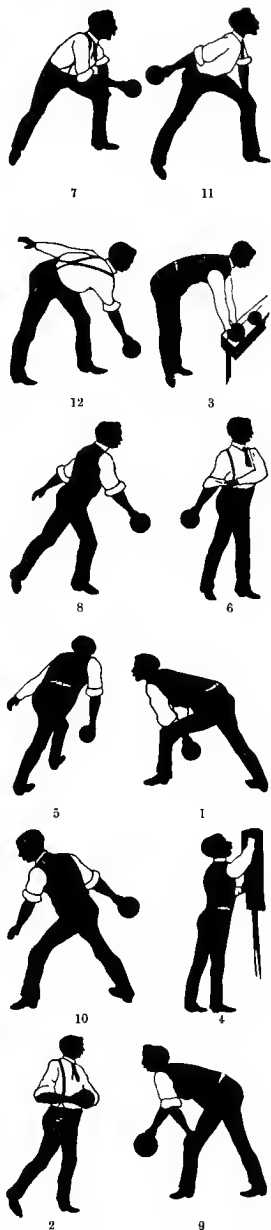

**Speakers** €

LARGE FONT \$2 50  
SMALL FONT \$1 50

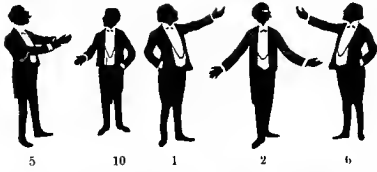

**Campaigners** A

PER FONT \$1 75

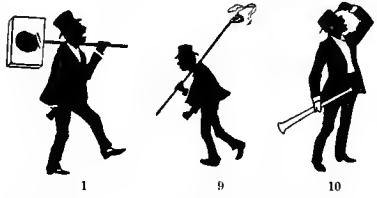
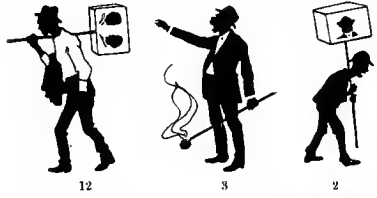

**Listeners** €

PER FONT \$1 50

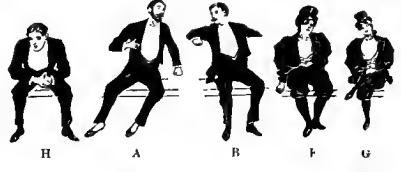

**Ballet Dancers** F

PER FONT \$2 00



# Large Scorchers

PER FONT

0

\$2 50



3



4



10



6



8



5



7



1



2



9

## Small Scorchers

PER FONT

0

\$1 50



15



18



11



19



12



14



16



20



17



13

## Rigs and Traps

PER FONT

\$1 50



5



7



1



2



4



6



3



4

AMERICAN TYPE FOUNDERS COMPANY

# Pick-Ups <sup>A</sup>

PER FONT \$1 75

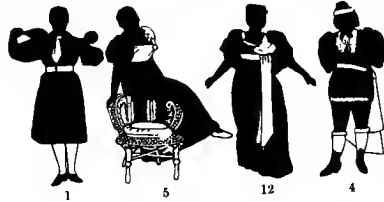
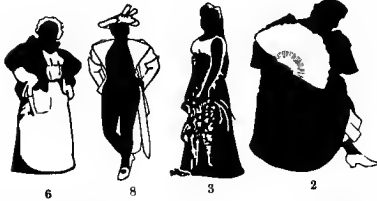
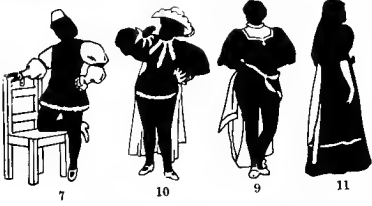

# Coppers <sup>F</sup>

PER FONT \$1 50



# Druggists <sup>F</sup>

PER FONT \$1 50

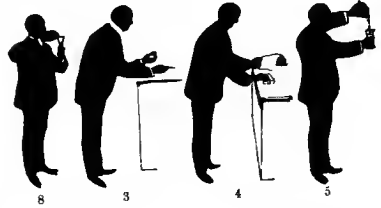

# Silhouettes <sup>A</sup>

PER FONT \$1 75



AMERICAN TYPE FOUNDERS COMPANY

# Domestics

PER FONT \$1 50



5



9



8



6



10



3



1



2



4



7

# Delmonico's Chefs and Waiters

PER FONT \$1 50



3



9



7



10



1



5



6



8



4



2

# Baseball Series No 1

PER FONT \$1 50



6



7



5



10



3



8



2



9



4



1

# Kate Greenaways Mignonettes

All cast in type mould



44. 30c.

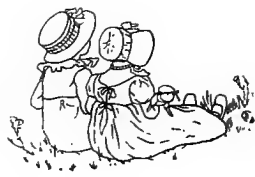

13. 30c.



43. 30c.



14. 30c.



51. 25c.



11. 25c.



41. 25c.



23. 25c.



43. 30c.



16. 30c.



46. 30c.



15. 30c.



56. 25c.



30. 25c.



53. 25c.



28. 25c.



48. 30c.



19. 30c.



58. 25c.



27. 25c.



54. 25c.



29. 25c.



32. 25c.



6. 25c.



35. 25c.



7. 25c.



55. 25c.



21. 25c.



22. 25c.



57. 25c.



10. 25c.



34. 25c.



1. 25c.

50. 25c.

AMERICAN TYPE FOUNDERS COMPANY



# Kate Greenaways Mignonettes

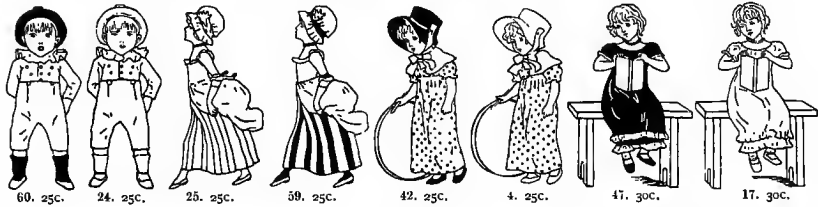
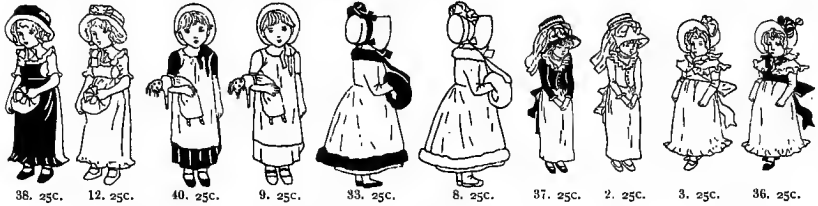
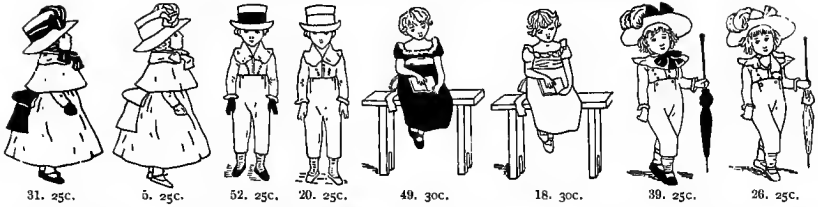

## Large Lady Speakers

PER FONT

\$2 00



## Small Lady Speakers

PER FONT

\$1 25



AMERICAN TYPE FOUNDERS COMPANY

**Perpetual  
Calendar  
Logotypes**

*No. 4.—\$2.50 per set, including fifty-two logotypes, rules and fonts for month and year; can be used for any month in any year; change made in three minutes.*

*No. 1.—\$4.00 per set, including fifty-two logotypes, rules and fonts for month and year; can be used for any month in any year; change made in three minutes*

Th APRIL 31

19 20 F

1898 SEPTEMBER 1898						
Su	Mo	Tu	We	Th	Fr	Sa
				1	2	3
4	5	6	7	8	9	10
11	12	13	14	15	16	17
18	19	20	21	22	23	24
25	26	27	28	29	30	
	Perpetual Calendar, No. 4					

1898		JUNE				1898	
SUN	MON	TUE	WED	THU	FRI	SAT	
			1	2	3	4	
5	6	7	8	9	10	11	
12	13	14	15	16	17	18	
19	20	21	22	23	24	25	
26	27	28	29	30			
	Perpetual Calendar, No. 1						

# Perpetual Calendar Logotypes

No. 3.—\$3.00 per set, including fifty-two logotypes, rules and fonts for month and year; can be used for any month in any year; can be changed in three minutes.

No. 2.—\$3.50 per set, including fifty-two logotypes, rules and fonts for month and year; can be used for any month in any year; can be changed in three minutes.

1898		<b>MARCH</b>					1898	
SUN	MON	TUE	WED	THU	FRI	SAT		
		1	2	3	4	5		
6	7	8	9	10	11	12		
13	14	15	16	17	18	19		
20	21	22	23	24	25	26		
27	28	29	30	31				
<b>Perpetual Calendar, No. 3</b>								

1898		<b>AUGUST</b>					1898	
Su	Mo	Tu	We	Th	Fr	Sa		
	1	2	3	4	5	6		
7	8	9	10	11	12	13		
14	15	16	17	18	19	20		
21	22	23	24	25	26	27		
28	29	30	31					
<b>Perpetual Calendar, No. 2</b>								

14

1898

SAT



U S

26

# Sectional Calendars

<b>189</b> <b>Sun</b> <b>1</b> <b>8</b> <b>15</b> <b>22</b>	1898		JULY				1898	
	Sun	Mon	Tue	Wed	Thu	Fri	Sat	
	--	--	--	--	--	1	2	
	3	4	5	6	7	8	9	
	10	11	12	13	14	15	16	
	17	18	19	20	21	22	23	
	24	25	26	27	28	29	30	
31	--	--	--	<i>Sectional Calendar No. 6. — \$3.00</i>				

1898		JUNE				1898	
Sun	Mon	Tue	Wed	Thu	Fri	Sat	
			1	2	3	4	
5	6	7	8	9	10	11	
12	13	14	15	16	17	18	
19	20	21	22	23	24	25	
26	27	28	29	30			
<i>Sectional Calendar, No. 5. — \$2.50</i>							

<i>Sectional Calendar No. 8. — \$4.00</i>		

	98	16
Wed	MARCH	

Rules and Figures for One Month, with Changes for Ten Years

# Newspaper Headings

## PRICE LIST

WIDTH OF HEADING	BODY—PICA MEASUREMENT						
	4-LINE	5-LINE	6-LINE	7-LINE	8-LINE	9-LINE	10-LINE
4 Column	\$2 00	\$2 25	\$2 50	\$2 75	\$3 00	\$3 25	\$3 50
5 "	2 25	2 50	2 75	3 00	3 25	3 50	3 75
6 "	2 50	2 75	3 00	3 25	3 50	3 75	4 00
7 "	2 75	3 00	3 25	3 50	3 75	4 00	4 25
8 "	3 00	3 25	3 50	3 75	4 00	4 25	4 50
9 "	3 25	3 50	3 75	4 00	4 25	4 50	4 75

STYLE NO 31

A

FOUR-LINE PICA

# TRIBUNE

STYLE NO 32

A

FIVE-LINE PICA

# LEDGER

STYLE NO 34

C

SIX-LINE PICA

# TORCH

STYLE NO 35

C

SIX-LINE PICA

# The Echo

AMERICAN TYPE FOUNDERS COMPANY

STYLE NO 36

c

FIVE-LINE PICA

COURIER

STYLE NO 37

c

SIX-LINE PICA

TRUTH

STYLE NO 38

c

SIX-LINE PICA

New Idea

STYLE NO 39

c

SIX-LINE PICA

THE SUN

STYLE NO 40

c

NINE-LINE PICA

ITEM

STYLE NO 44

F

SIX-LINE PICA

The Item

STYLE NO 45

C

FIVE-LINE PICA

CITIZEN

STYLE NO 46

C

FIVE-LINE PICA

Atco Sun

STYLE NO 46

F

SIX-LINE PICA

SENTINEL

STYLE NO 49

A

SIX-LINE PICA

TRIBUNE

**Newspaper Headings**

*For prices, see page 417*

STYLE NO 50

SIX-LINE PICA

**CIRCUIT**

STYLE NO 51

SIX-LINE PICA

**Recorder**

STYLE NO 54

FIVE-LINE PICA

**Raleigh Leader**

STYLE NO 55

EIGHT-LINE PICA

**Democrat**

STYLE NO 57

EIGHT LINE PICA

**Telegraph**

AMERICAN TYPE FOUNDERS COMPANY



**Newspaper Headings**

*For prices, see page 417*

STYLE NO 60

A

FIVE-LINE PICA

**Salem Item**

STYLE NO 62

B

SEVEN-LINE PICA

**Journals**

STYLE NO 65

C

EIGHT-LINE PICA

**Chronicle**

STYLE NO 67

D

EIGHT-LINE PICA

**Mechanic**

STYLE NO 69

E

SEVEN-LINE PICA

**Neue Welt**

## Commercial Logotypes

No. 501C. 10 cts. <i>189</i>	No. 502C. 10 cts. <i>189</i>	No. 503C. 10 cts. <i>189</i>	No. 504C. 10 cts. <i>189</i>	No. 508C. 10 cts. <i>Dr</i>	No. 516C. 10 cts. <i>Cr</i>
No. 509C. 10 cts. <i>To</i>	No. 512C. 10 cts. <i>Mc</i>	No. 513C. 10 cts. <i>M</i>	No. 514C. 10 cts. <i>No.</i>	No. 515C. 10 cts. <i>No.</i>	No. 511C. 10 cts. <i>Mc</i>
No. 546C. 15 cts. <i>Mc</i>	No. 547C. 15 cts. <i>M</i>	No. 548C. 15 cts. <i>No.</i>	No. 549C. 15 cts. <i>No.</i>	No. 566C. 30 cts. <i>Received</i>	
No. 544C. 15 cts. <i>Dr</i>	No. 545C. 15 cts. <i>To</i>	No. 550C. 15 cts. <i>Cr</i>	No. 569C. 25 cts. <i>Bought of</i>		
<i>Buffalo Dollars and charge to account of</i>					
<small>Solid body Electros, set in 28 Point Spencerian Script No. 2, as in line above, furnished at 25 cents per lineal inch</small>					
<i>Bought of Dollars New York</i>					
<small>Solid body Electros, set in 40 Point Spencerian Script No. 2, as in line above, furnished at 30 cents per lineal inch</small>					

## Billhead Logotypes



AMERICAN TYPE FOUNDERS COMPANY

# Check Blanks

*In ordering be careful to add the words "Check Blank" to the No. wanted*

No. 327C. 75 cts.



No. 329C. 40 cts.



No. 327½C. 75 cts.



No. 323C. 75 cts.

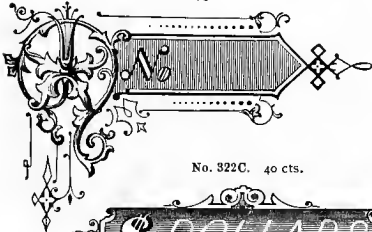

No. 322C. 40 cts.



No. 323½C. 75 cts.

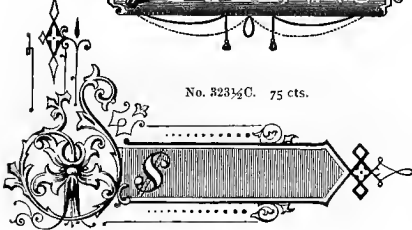

No. 320C. 50 cts.

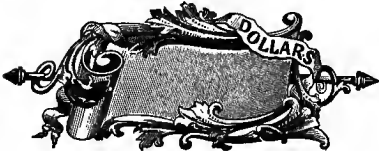

No. 328C. 75 cts.

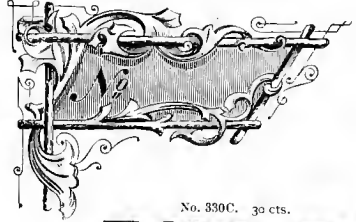

No. 330C. 30 cts.



No. 328½C. 75 cts.

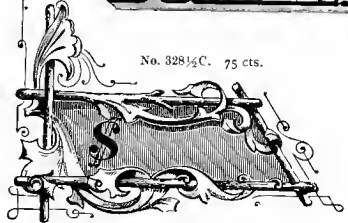

No. 326C. 75 cts.



No. 321C. 40 cts.



No. 326½C. 75 cts.

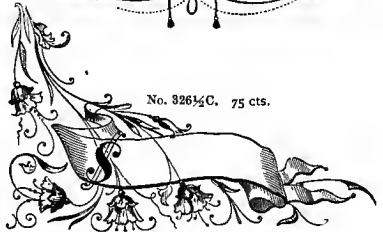

No. 319C. 50 cts.

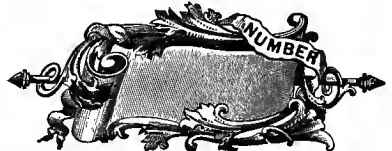

AMERICAN TYPE FOUNDERS COMPANY

# Society Emblems

No. 241B. 40 cts.



No. 216B. 90 cts.

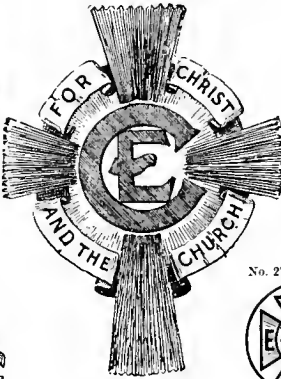

No. 226B. 75 cts.



No. 245B. 35 cts.



No. 278B. 40 cts.



No. 229B. 50 cts.



No. 2031E. \$1.25



For two colors, \$1.50

No. 232B. 60 cts.

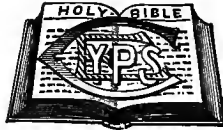

No. 237B. 70 cts.



No. 215B. 75 cts.



No. 223B. 50 cts.

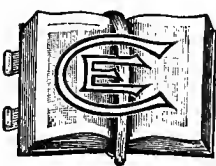

No. 242B. 40 cts.



No. 240B. 40 cts.



No. 243B. 40 cts.



No. 235B. 40 cts.



No. 236B. 40 cts.



AMERICAN TYPE FOUNDERS COMPANY

No. 213B. 75 cts.

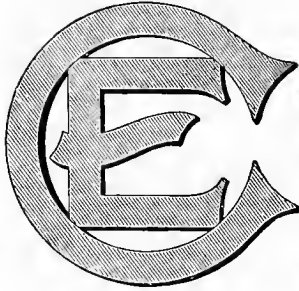

No. 214B. 60 cts.

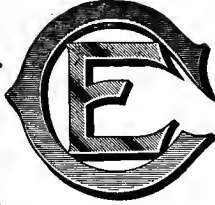

No. 239B. 90 cts.



No. 217B. 35 cts. No. 220B. 35 cts.



No. 224B. 60 cts.



For two colors, \$1.00

No. 221B. 40 cts.



No. 4152C. 40 cts.



No. 4153C. 30c.



No. 230B. 60 cts.



No. 225B. 60 cts.

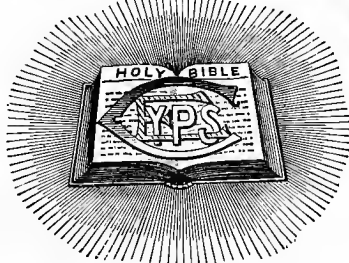
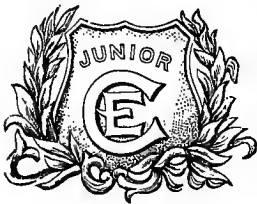

For two colors, \$1.50

No. 233B. 50 cts.



No. 228B. 75 cts.



No. 227B. 50 cts.



No. 222B. 40 cts.



No. 238B. 75 cts.



No. 234B. 75 cts.



No. 244B. 75 cts.

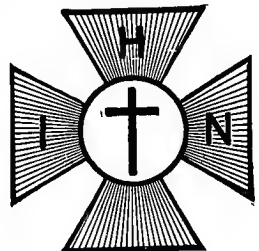

AMERICAN TYPE FOUNDERS COMPANY

No. 2077E. 75c.



No. 2309½C. 38c.



No. 3170C. 40c.



No. 3168C. 40c.



No. 3361C. 50c.



No. 2135C. 25c.



No. 3172C. 30c.



No. 3030C. 30c.



No. 420C. 30c.



No. 2971C. 25c.



No. 3169C. 80c.

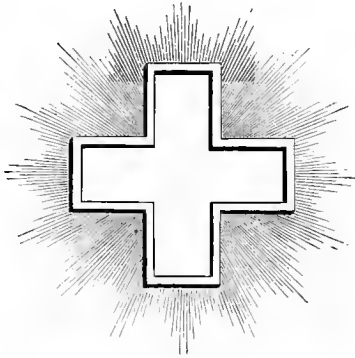

No. 3166C. 40c.

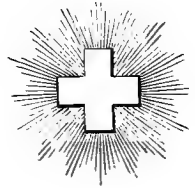

No. 3455C. 50c.



No. 1225C. 25c.



No. 3653C. 35c.



No. 3359C. 25c.



No. 3655C. 30c.



No. 3372C. 35c.



No. 2998C. 25c.



No. 3171C. 30c.



No. 3002½C. 15c.



No. 236C. 8c.



No. 3279C. 50c.



No. 3031C. 30c.



No. 3362C. 30c.



No. 2080E. 35c.



No. 3407C. 60c.



AMERICAN TYPE FOUNDERS COMPANY

No. 3356C. 35c.



No. 2079E. 75c.



No. 3364C. 30c.



No. 3165C. 40c.



No. 3167C. 40c.

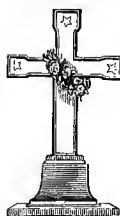

No. 3365C. 35c.



No. 3357C. 35c.



No. 3380C. \$2.00

No. 3384C. \$2.00



No. 2081E. 70c.



No. 2078E. \$1.25



No. 3356C. 40c.



No. 3383C. 35c.



No. 3354C. 35c.



No. 3358C. 25c.



No. 3363C. 30c.



AMERICAN TYPE FOUNDERS COMPANY

No. 3083A. \$1.00



No. 3079A. \$1.00



No. 168B. 75 cts.



No. 4140C. \$1.00



No. 3066A. 75 cts.



No. 3044A. 75 cts.



No. 3327A. 75 cts.



No. 2432C. 50 cts.



No. 8078A. 75 cts.

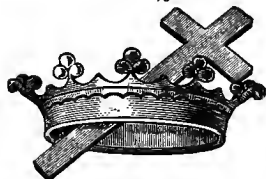

No. 1850A. 40 cts.



No. 3027A. 30 cts.



No. 3059A. 75 cts.



No. 2079A. 50 cts.



No. 172B. 25c.



No. 3109A. 35 cts.



No. 170B. 40c.



No. 3653C. 35 cts.



No. 388B. 12c.



No. 3323A. 60 cts.



No. 8077A. 40 cts.



No. 3401C. 50 cts.



No. 3402C. 50 cts.



No. 3403C. 50 cts.



No. 3404C. 50 cts.



No. 3400C. 50 cts.



No. 3399C. 50 cts.



AMERICAN TYPE FOUNDERS COMPANY



No. 3970C. 60 cts.

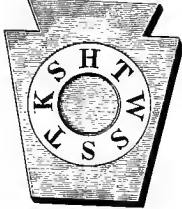

No. 3455C. 50 cts.



No. 3072A. \$1.00



No. 3682C. 50 cts.



No. 3060A. \$1.00



No. 3321A. \$1.00



No. 3654C. 40 cts.



No. 3024A. 30c.



No. 1230F. 75 cts.

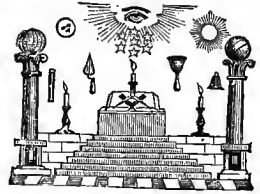

No. 2431C. \$1.00

No. 81B. 15c. No. 83B. 15c. No. 79B. 15c.



No. 3454C. \$1.00

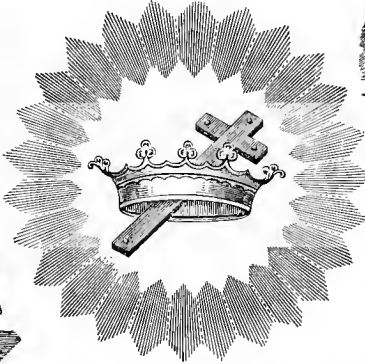

No. 2438A. Mortised. \$1.00

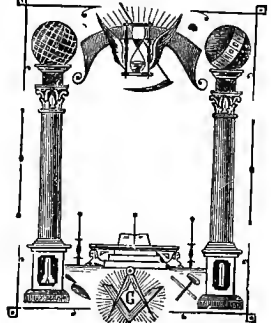

No. 77B. 15c. No. 82B. 15c. No. 80B. 15c.



No. 164B. 50 cts.

No. 2241A. 75 cts.



For three colors, \$1.25

No. 2434A. Mortised. \$1.00



No. 163B. 75 cts.



For three colors, \$1.50

No. 2970C. 50 cts.



AMERICAN TYPE FOUNDERS COMPANY

No. 174B. \$1.00



For two colors, \$1.50

No. 176B. \$1.00



For two colors, \$1.50

No. 3123A. \$1.00



No. 177B. 35 cts.



No. 3104A. 40 cts.



No. 3119A. 75 cts.

No. 2766A. 90 cts.

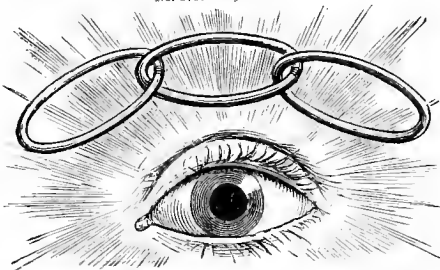

No. 3118A. 75 cts.



No. 12,103C. 50 cts.



No. 3121A. \$1.00



No. 3656C. 40 cts.

No. 181B. 60 cts.



No. 3110A. 40 cts.



No. 173B. 25 cts.



No. 46B. 25 cts.



No. 3099A. 30 cts.



No. 12,102C. 60 cts.



No. 175B. \$1.00



No. 12,101C. 75 cts.



No. 3122A. \$1.00



AMERICAN TYPE FOUNDERS COMPANY

No. 3185A. \$1.00

No. 3190A. \$1.25

No. 4123C. 75 cts.

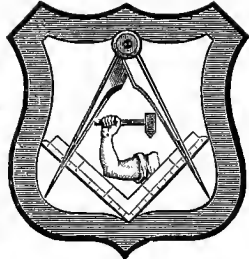

No. 4144C. 60 cts.

No. 3661C. 30c.

No. 4115C. 30c.

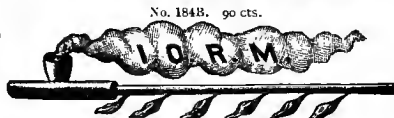
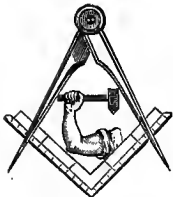

No. 184B. 90 cts.



No. 1264F. 75 cts.



No. 3089A. 75 cts.

No. 3637C. 40 cts.

No. 1262F. 50 cts.

No. 267B. 75 cts.

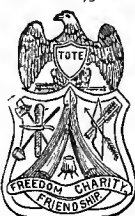

No. 183B. 40 cts.

No. 3658C. 35 cts.

No. 1280F. 50 cts.



No. 3136A. 60 cts.



No. 3092A. 50 cts.

No. 2820A. 50 cts.

No. 3135A. 40c.



No. 3356A. 50 cts.



No. 3129A. 60 cts.



No. 3098A. 60 cts.

No. 3157A. 60 cts.

No. 1361F. 50 cts.



AMERICAN TYPE FOUNDERS COMPANY

No 190B. \$1.25



No 3996C. 75 cts.



No. 3419C. 75 cts.



No 155B. \$1.00



No. 12,106C. 75 cts.

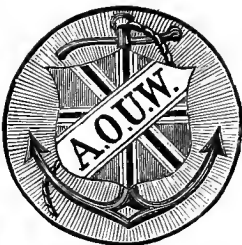

No. 191B. 50c.



No. 3191A. 75 cts.



No. 3790C. \$1.00

No. 3417C. 30c.



No. 3126A. 60cts.

No. 3662C. 40c.



No. 2601A. 65 cts.

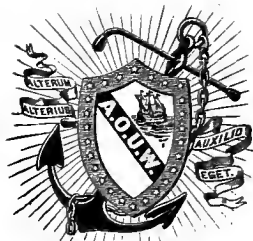

No. 12,105C. 35c.



No. 3418C. 60 cts.



No. 3186A. \$1.00



No. 197B. \$1.00



No. 12,104C. 75 cts.



AMERICAN TYPE FOUNDERS COMPANY

No. 3168A. 60 cts.



No. 12,111C. 50 cts.



No. 3171A. \$1.00



No. 12,107C. 75 cts.



No. 12,118C. Mortised. \$1.00



No. 12,117C. Mortised. \$1.00



No. 12,115C. 50 cts.



No. 12,112C. 50 cts.



No. 12,109C. 35 cts.



No. 12,114C. 75c.



No. 254B. \$1.00

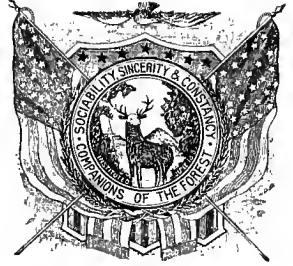

No. 12,116C. 75 cts.



No. 12,113C. Mortised. \$1.00



No. 12,110C. 35 cts.



No. 12,108C. 30c.



No. 12,119C. 40 cts.



AMERICAN TYPE FOUNDERS COMPANY

No. 3972C. 60 cts.



No. 3152A. \$1.00



No. 260B. 75 cts.



No. 3153A. \$1.00



Mortised for name of Lodge.

No. 3167A. \$1.00

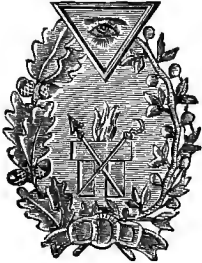

No. 3161A. 75cts.

No. 192B. 75 cts.



For four colors, \$2.00

No. 3162A. 60 cts.



No. 261B. 40 cts.



No. 3132A. 50 cts.



No. 3133A. 60 cts.



No. 1207F. 50 cts.

No. 3139A. 60 cts.



No. 3146A. 60 cts.



No. 255B. Mortised. \$1.50



No. 3159A. 50 cts.



No. 1277F. 50 cts.



No. 1258F. 60 cts.



No. 1208F. 60 cts.



AMERICAN TYPE FOUNDERS COMPANY

No. 2011E. \$1.00



No. 23194A. 75 cts.

No. 12,120C. Mortised. \$1.00



No. 2048C. 75 cts.

No. 12,124C. 60 cts.

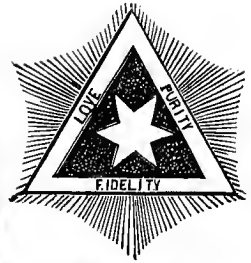

No. 256B. 75 cts.



No. 12,122C. 50 cts.



No. 3154A. \$1.00



No. 3076A. 60 cts.

No. 3659C. 40 cts.



No. 1274E. 40 cts.



No. 3685C. 50 cts.



No. 3148A. 50 cts.

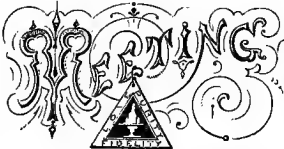

No. 12,123C. 50 cts.



No. 3150A. 60 cts.

No. 3142A. 50 cts.



No. 3149A. 75 cts.

No. 12,121C. 35 cts.



No. 3147A. 50 cts.

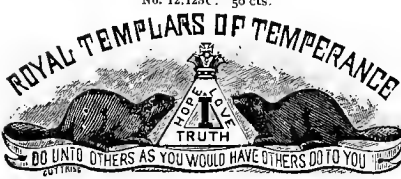

AMERICAN TYPE FOUNDERS COMPANY

No. 248B. 75 cts.



No. 268B. \$1.15

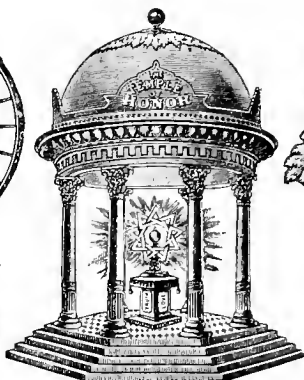

No. 262B. 75 cts.



No. 1273F. 50 cts.



No. 246B. 40c. No. 3176A. 50c.



No. 263B. 75 cts.



No. 2857A. \$1.00

No. 4124C. \$1.00

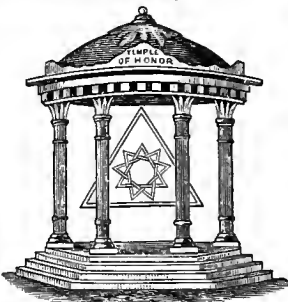
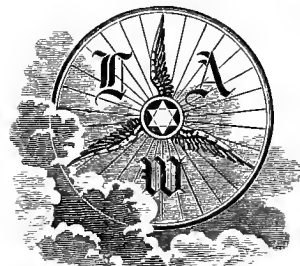

No. 31-9A. 50 cts.



No. 3170A. 60 cts.

No. 4121C. 40 cts.



No. 247B. 50 cts.



No. 1301F. 40 cts.



No. 251B. 50 cts.



No. 2014A. 40 cts.

No. 3141A. 50 cts.

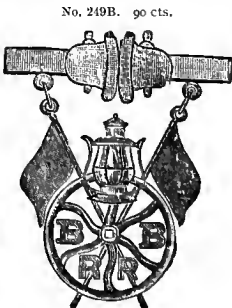

No. 249B. 90 cts.



No. 3131A. 60 cts.



No. 12,152C. 40 cts.

No. 250B. 50 cts.

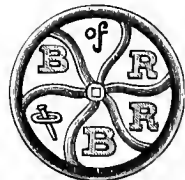

No. 252B. 50 cts.



No. 266B. 50 cts.



AMERICAN TYPE FOUNDERS COMPANY



No. 12,158C. 60 cts



No. 3200A. \$1.00

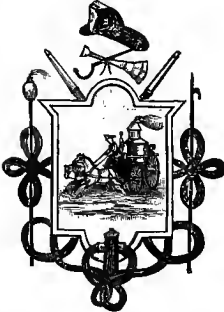

No. 3272C. 75 cts.



No. 1874D. 75 cts.



No. 3198A. \$1.00



No. 3201A. 75 cts.



No. 1873D. 60 cts.



No. 1870D. 25 cts.



No. 1871D. 35c.



No. 448C. 30c.



No. 3273C. \$1.00

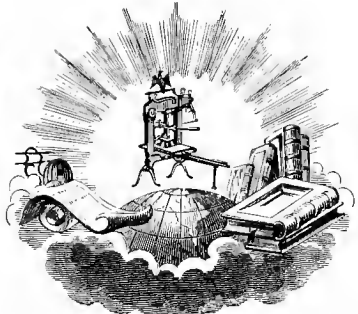

No. 828A. \$1.00

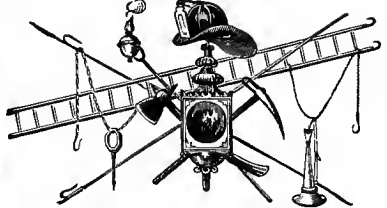

No. 3784C. 50 cts.

No. 3272D. 50 cts.



No. 3290C. 50 cts.

No. 127B. 35c.



No. 3034C. Mortised. \$1.00

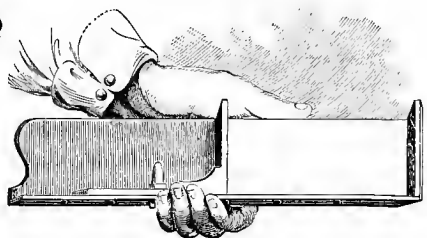

AMERICAN TYPE FOUNDERS COMPANY

No. 12,164C. 40 cts.



No. 234A. 40 cts.



No. 12,166C. 25 cts.



No. 12,169C. 65 cts.



No. 12,166C. 50 cts.



No. 205B. 75 cts.



No. 3711C. 35 cts.



No. 12,161C. 50 cts.



No. 987A. 60 cts.



No. 3172A. 50 cts.



No. 12,162C. 50 cts.

No. 209B. 50 cts.



No. 4185C. 75 cts.



No. 2067E. 75 cts.



No. 3178A. 75 cts.

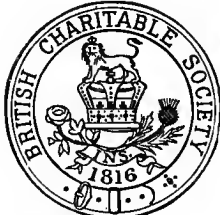

No. 12,167C. 30c.



No. 2069A. 30c.



No. 203B. \$1.00

No. 12,165C. \$1.00



No. 204B. 90 cts.



No. 12,163C. 40 cts.



AMERICAN TYPE FOUNDERS COMPANY

No. 207B. 90 cts.



No. 3144 A. 60 cts.



No. 3194A. \$1.25



No. 259B. \$1.00

No. 12,155C. 60 cts.

No. 206B. 60 cts.



No. 3143A. 60 cts.

No. 208B. 40c.

No. 12,154C. 50 cts.



No. 3196A. \$1.25

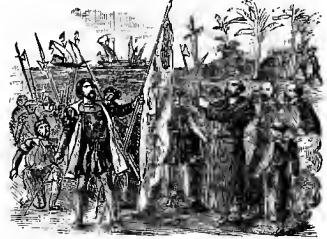

No. 12,160C. 40 cts.

No. 3145A. 30c.



No. 211B. 75 cts.



No. 12,156C. 35 cts.

No. 12,159C. 30c.

No. 12,157C. 25c.



No. 12,158C. 90 cts.

No. 1865C. 30c.

No. 212B. 90 cts.



No. 3174A. 60c.



No. 12,142C. 75 cts.



No. 2034E. 75 cts.



No. 12,149C. 40 cts.

No. 12,146C. 30c.



No. 12,151C. 75 cts.



No. 2982A. 30c.



No. 2037E. 50 cts.



No. 12,148C. 75 cts.



No. 2040E. 25c.



No. 3982C. 30c.



No. 2036E. 50 cts.



No. 2039E. 35 cts.

No. 12,143C. 25c.



No. 12,144C. 30 cts.



No. 12,141C. 60 cts.



No. 12,130C. 50 cts.

No. 12,145C. 35c.



No. 12,150C. 30c.



No. 12,129C. 50 cts.



No. 12,117C. 40 cts.

No. 12,138C. 40 cts.



AMERICAN TYPE FOUNDERS COMPANY

No. 12,125C. \$1.25

No. 12,126C. 35 cts.

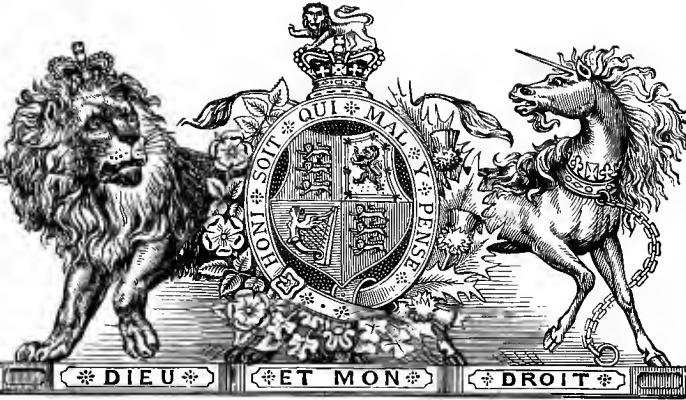

No. 12,127C. 30 cts.



No. 12,128C. 35 cts.



No. 12,132C. 35 cts.

No. 12,140C. 75 cts.



No. 12,139C. 50 cts.

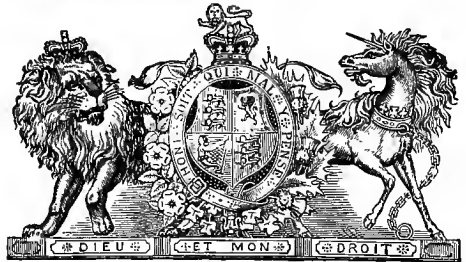

No. 12,135C. 50 cts.

No. 12,137C. 40 cts.

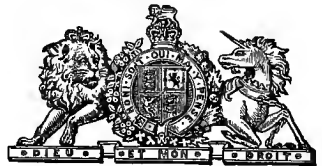

No. 12,136C. 40 cts.

No. 12,131C. \$1.25



No. 12,134C. 35 cts.



No. 12,138C. 35 cts.

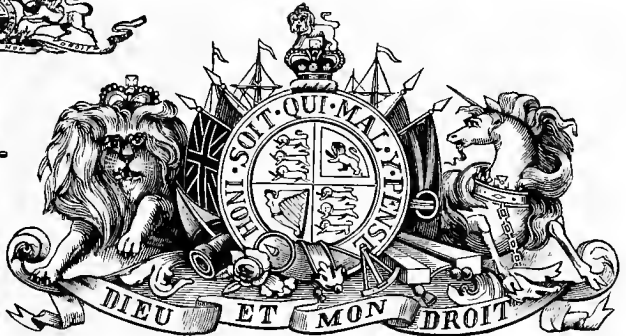

AMERICAN TYPE FOUNDERS COMPANY

No. 2537C. 50 cts.



No. 2709C. 50 cts.



No. 2711C. 50 cts.



No. 2436C. Mortised. \$1.25



No. 2471C. 50 cts.



No. 3023C. 25 cts.

No. 2442C. 30 cts.



No. 2922C. Mortised. \$1.25

No. 2213 1/4 C. \$1.50  
This fits in Border No. 2370C, \$2.50, similar to  
Border No. 2751 at top of page 444



No. 2386C. \$1.25

No. 2385C. 75 cts.



AMERICAN TYPE FOUNDERS COMPANY

No. 3929C. Mortised. \$1.85

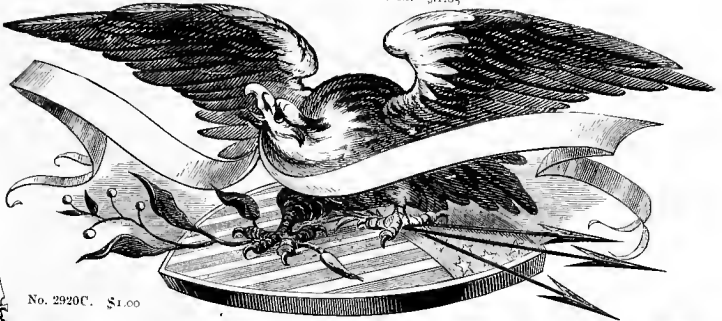

No. 2920C. \$1.00



No. 3460C. 25 cts.



No. 2443C. 30 cts



No. 3182C. 75 cts.



No. 2290 1/2 C. 75 cts.

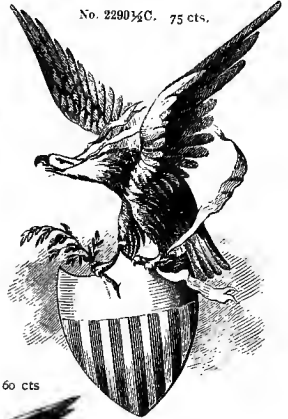

No. 3181C. 60 cts

No. 2266C. Mortised. \$1.00

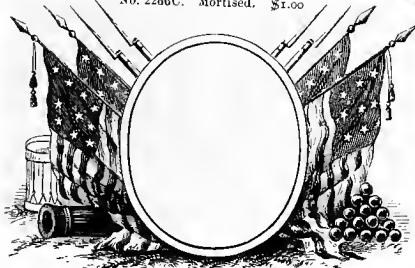

No. 3073C. 75 cts.



No. 2389C. \$1.00



No. 1906C. 30c.



No. 4100F. 25c.



AMERICAN TYPE FOUNDERS COMPANY



\*No. 279B 75 cts.

Seal (only) \*No. 2759C. 75 cts.

\*No. 280B 75 cts.



\*No. 2222C. \$1.50

### State Seals

THE American Type Founders Company makes four Series of State Seals, each complete, and correct to date. All State Seals indicated by an (\*) asterisk on this and the following page belong to series, and correct Seals of any of the States can be furnished of same styles and at same prices.



\*No. 2220C. \$1.50

Border No. 2370C. \$2.50.

Similar design to the above Border, and mortised to take the Seal of any State in this Series.

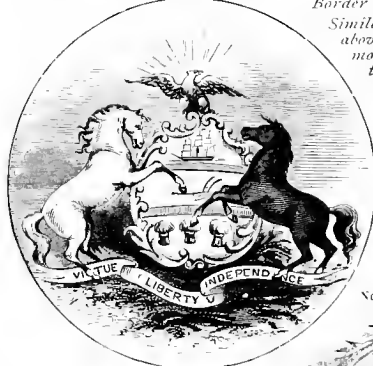

No. 3487C. \$1.00



\*No. 2761C. 75 cts.

\*No. 2776C. 75 cts.





No. 3124C. \$1.00

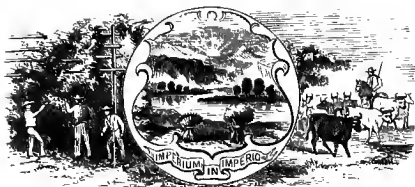

No. 3109C. \$1.00

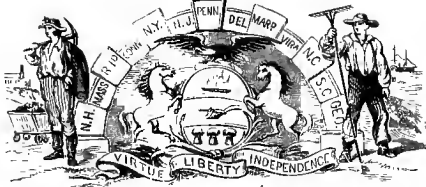

No. 3813C. 50 cts.



No. 2509 3/4 C. 50 cts.



No. 3107C. \$1.00

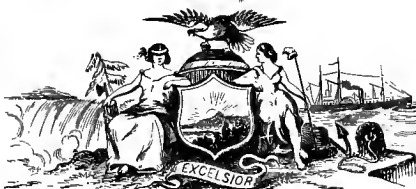

No. 3718C. \$1.00

No. 3717C. 75 cts.



No. 3815C. \$1.25

No. 12,175 C. 50 cts.



No. 3719C. \$1.50

No. 3716C. 50 cts.

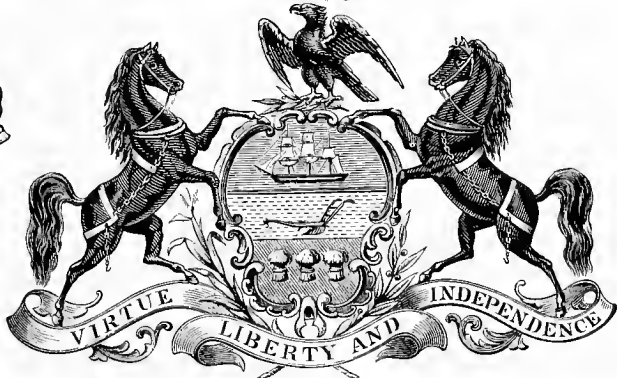

No. 2421C. 50 cts.



AMERICAN TYPE FOUNDERS COMPANY

No. 2022E. \$1.00



No. 196B. 60 cts.



No. 202B. 75 cts.



No. 1109F. \$1.00



No. 3952C. \$1.00



No. 198B. 60 cts.



No. 197B. 60 cts.



No. 200B. 90 cts.



No. 201B. 75 cts.



No. 3953C. 75 cts.



For four colors, \$2.50

No. 193B. 45 cts.



No. 4125C. 40 cts.



AMERICAN TYPE FOUNDERS COMPANY

No. 2435C. \$1.50



No. 3778C. \$1.50

No. 4086C. 40 cts.



No. 3818C. \$1.50



No. 2439C 37 cts



No. 2904C. 50 cts.



No. 162B. \$1.25



No. 3779C. \$1.00



No. 4141C. 75 cts.



No. 4148C. 40 cts.



No. 2708C. \$1.50



AMERICAN TYPE FOUNDERS COMPANY

No. 320C. 40 cts.



No. 2942C. 15 cts.



No. 132B. 30 cts.



No. 2817C. 40 cts.



No. 3409C. \$1.00



No. 2411C. \$1.00



No. 3281C. 60 cts.



No. 3445C. 50 cts.



No. 3293C. 30 cts.



No. 3051C. 75 cts.



No. 1609C. 30 cts.



No. 2943C. 15 cts.

No. 2490C. \$1.00



No. 3175C. 80 cts.



No. 2419C. 40 cts.



No. 3467C. 75 cts.



No. 3438C. 40 cts.



AMERICAN TYPE FOUNDERS COMPANY

No. 3143C. \$1.00



No. 3271C. 60 cts.

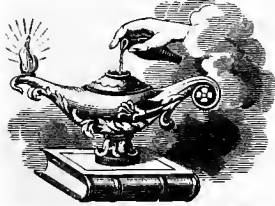

No. 3142C. \$1.00



No. 3084C. 75 cts.



No. 4096C. \$1.25



No. 2302C. 50 cts.

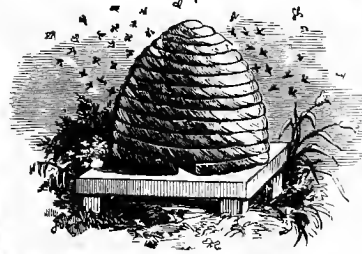

No. 3085C. \$1.00



No. 3796C. \$1.25

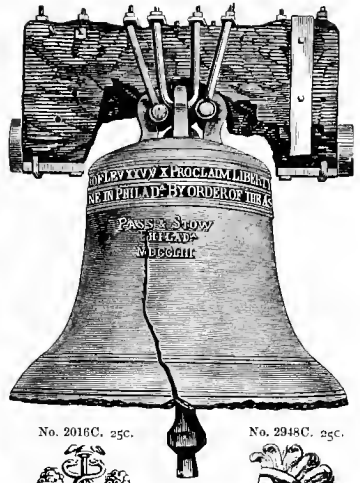

No. 2016C. 25c.

No. 2948C. 25c.



No. 3795C. 75 cts.

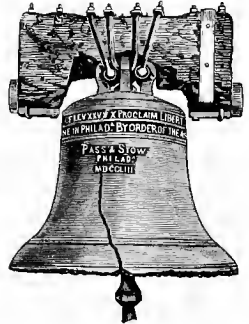

No. 3794C. 50 cts.



No. 2941C. 25 cts.



AMERICAN TYPE FOUNDERS COMPANY

No. 4201C. 50 cts.



No. 4211C. 50 cts.



No. 4209C. 50 cts.



No. 4205C. 50 cts.

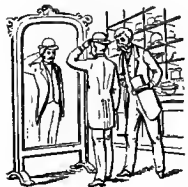

# Electrotyped Outline Figures

FIRST SERIES. 30 cts. each



SECOND SERIES. 40 cts. each



THIRD SERIES. 40 cts. each



FOURTH SERIES. 50 cts. each

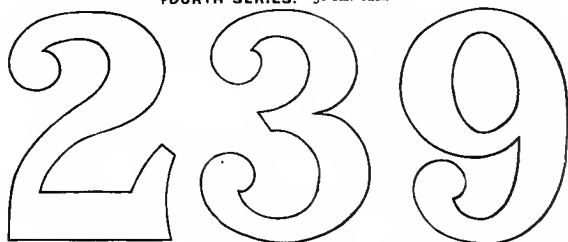

No. 3958C. 90 cts.



No. 3969C. 90 cts.



AMERICAN TYPE FOUNDERS COMPANY

# Index Corners

COPYRIGHTED

No. 3986C.

No. 3987C.

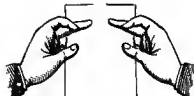

No. 3991C.

No. 3990C.



No. 3989C.

No. 3988C.



No. 3992C.

No. 3993C.

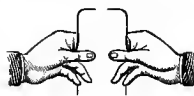

No. 4037C.



No. 4048C.



No. 4044C.



No. 4038C.



No. 4039C.

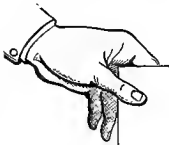

No. 4041C.

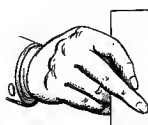

No. 4042C.

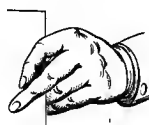

No. 4040C.



No. 4047C.

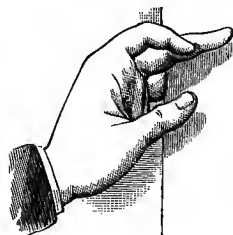

No. 4058C.

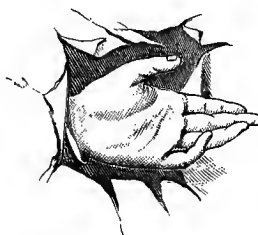

No. 4048C.

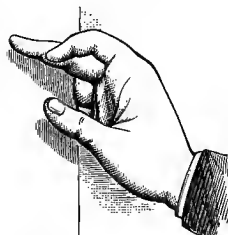

No. 4046C.



No. 4051C.

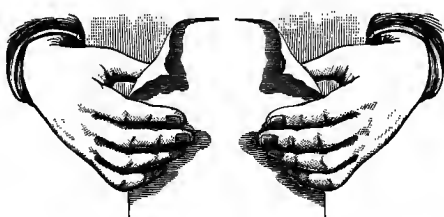

No. 4052C.



No. 4045C.

No. 4049C.



No. 4050C.



## PRICES

Nos. 3986C to 3993C, set of eight,	\$1.75
Single Corner,	.25
Nos. 4037C to 4044C, set of eight,	2.50
Single Corner,	.35
Nos. 4045C to 4052C, set of eight,	3.50
Single Corner,	.50
No. 4053C,	.50

ELECTROTYPED ON SOLID METAL BODIES

AMERICAN TYPE FOUNDERS COMPANY

No. 3787C. \$1.25



No. 2076E. 50 cts.



No. 3215C. 75 cts.



No. 3995C. 60 cts.



No. 3212C. 75 cts.

No. 2074E. 60 cts



No. 1127C. 75 cts



No. 3677C. \$1.25

No. 3756C. \$1.25

No. 1386D. 50 cts.



No. 2075E. \$1.00

No. 2954C. 25c.



No. 2945C. 25 cts.

No. 2952C. 25 cts.

No. 2396C. 25 cts.



No. 2090E. 40 cts.

No. 3452C. 30 cts.

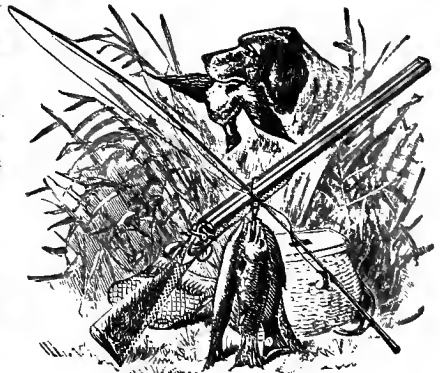

AMERICAN TYPE FOUNDERS COMPANY



No. 2057E. \$1.00

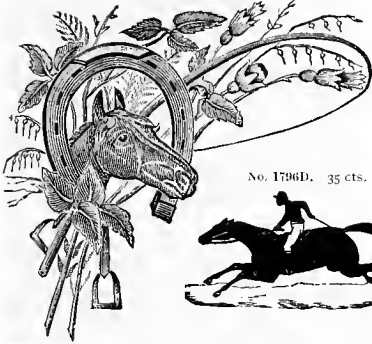

No. 1796D. 35 cts.



No. 1629D. 75 cts.

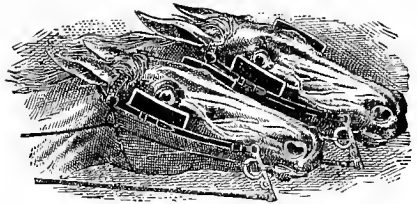

No. 12,171C. \$1.00

No. 4124F. 30 cts.



No. 3785C. 75 cts.

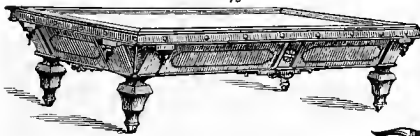

No. 4125F. 30 cts.



No. 3436C. 60 cts.



No. 3957C. 60 cts.

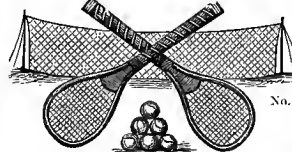

No. 123B. 25 cts.

No. 3204C. 60 cts.



No. 1856C. 30 cts.



No. 12312 1/2 C. 38 cts.



No. 12,173C. 40 cts.

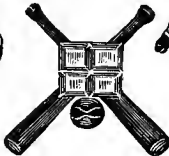

No. 1783C. 50 cts.

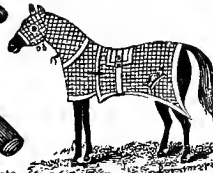

No. 2043E. Mortised. \$1.25

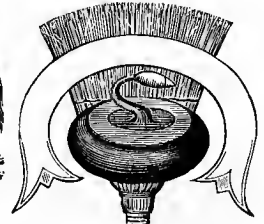

No. 12,172C. 50 cts.

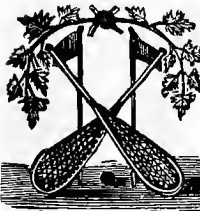

No. 12,170C. 40 cts.

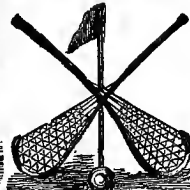

No. 2906C. 75 cts.

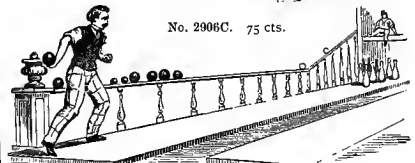

AMERICAN TYPE FOUNDERS COMPANY

No. 2092C. 50 cts.



No. 115B. 25 cts.



No. 3087C. 60 cts.

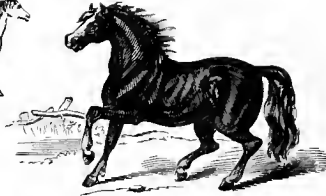

No. 3378C. 50 cts.



No. 4117F. 25 cts.



No. 2052E. \$1.00



No. 12174C \$1.00

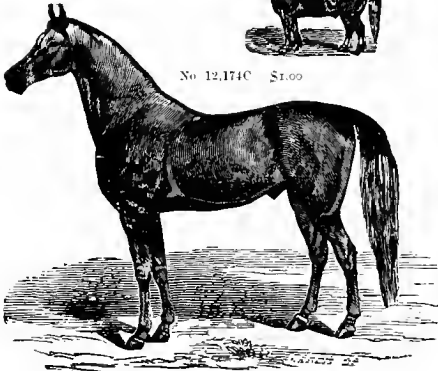

No. 3038C. 60 cts.



No. 2658F. 25c.

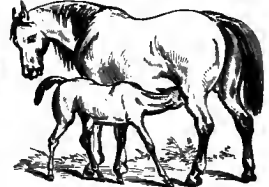

No. 3370C. 50 cts.



No. 2695C. 75 cts.



No. 3255C. 75 cts.



No. 2054E. \$1.00



No. 2055E. \$1.00



AMERICAN TYPE FOUNDERS COMPANY

No. 3471C. 75 cts.

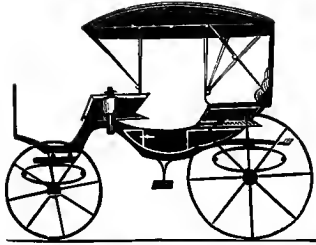

No. 2332C. \$1.00



No. 2049E. \$1.00



No. 2050E. \$1.00

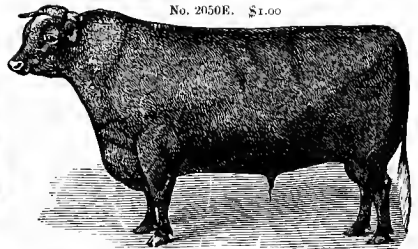

No. 2856C. 50 cts.



No. 3062C. 30 cts.



No. 2817C. 40 cts.



No. 4092C. 75 cts.

No. 4065F. 20c.



No. 2470C. 75 cts.

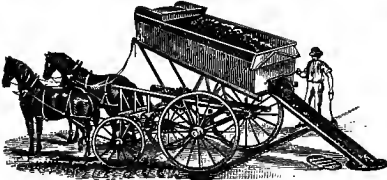

No. 12,175C. 50 cts.

No. 3456C. \$1.00



No. 3380C. \$1.00

No. 2066E. \$1.00

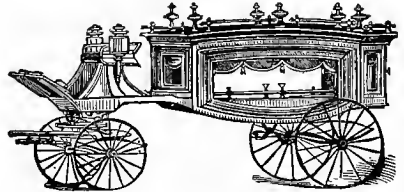

AMERICAN TYPE FOUNDERS COMPANY

No. 4099C. \$1.00

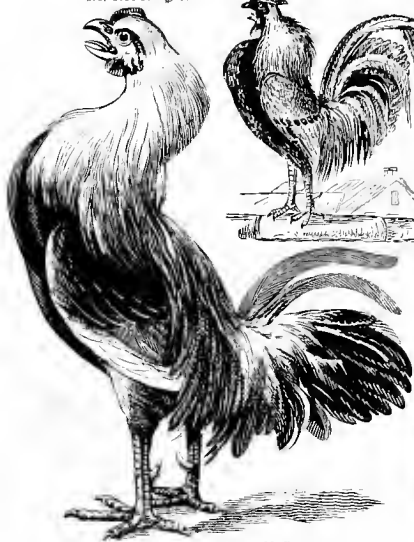

No. 2035C. 50 cts.

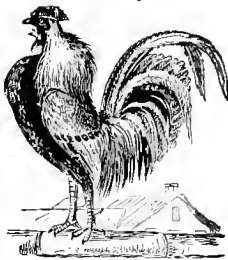

No. 2929C. \$1.00



No. 3816C. \$1.50

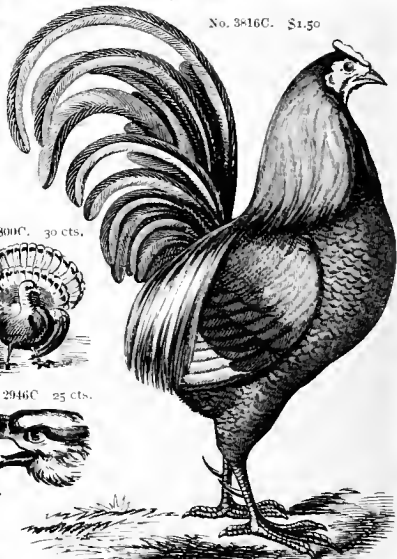

No. 3055C. 40 cts.



No. 3559B. 50 cts.



No. 3800C. 30 cts.



No. 1750A. 50 cts.



No. 2946C. 25 cts.



No. 2727. 25 cts.



No. 3944C. 25 cts.



No. 4042F. 25 cts.



No. 215C. 50 cts.



No. 2726C. 25 cts.



No. 3156C. \$1.00



AMERICAN TYPE FOUNDERS COMPANY

No. 3997C. 75 cts. (No. 4120C. 75 cts. Same cut with the initials B. L. E.)

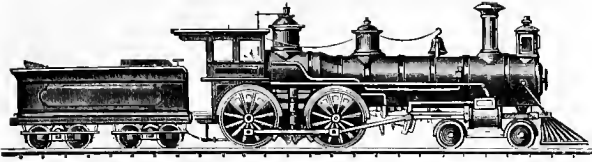

No. 3466C. 50 cts.

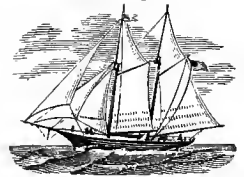

No. 2060E. 90 cts.

No. 4167C. 40 cts.

No. 2418C. 50 cts.

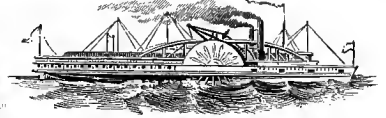
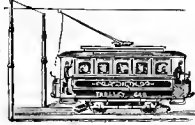
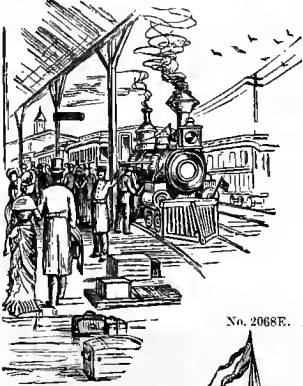

No. 2062E. \$1.00

No. 2068E. \$1.00

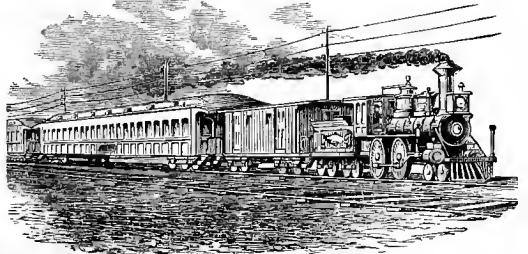

No. 2072E. \$1.00

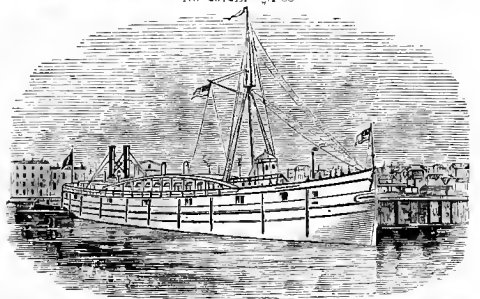
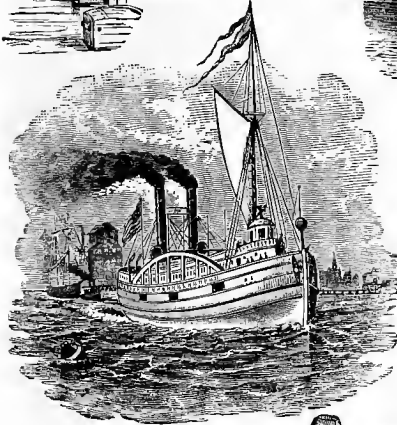

No. 2058E. 90 cts.

No. 2069E. 75 cts.



No. 1744D. 35 cts.

No. 3941C. \$1.00

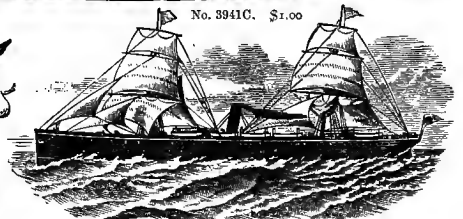
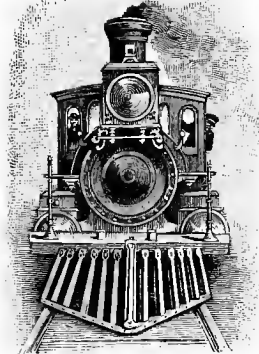

No. 320E. 12 cts.



AMERICAN TYPE FOUNDERS COMPANY

No. 4066C. 75 cts.



No. 4065C. 75 cts.

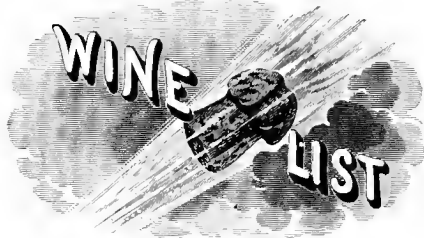

No. 4070C. 60 cts.



No. 4058C. 75 cts.



No. 4071C. 75 cts.



No. 4056. 75 cts.



No. 4060C. 60 cts.

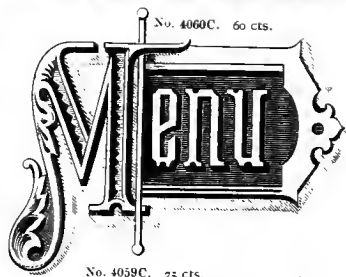

No. 4059C. 75 cts.



No. 4054C. 75 cts.



No. 4069C. 75 cts.



AMERICAN TYPE FOUNDERS COMPANY

No. 3148C. 75 cts.

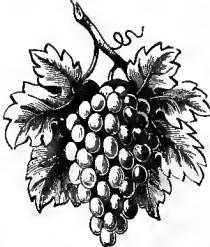

No. 2285C. 37 cts.



No. 2997C. \$1.00

No. 2105A. 50 cts.



No. 10,332D. 80 cts.

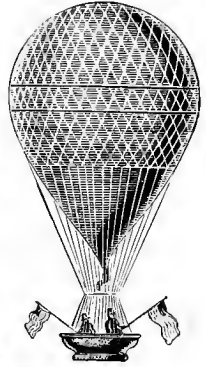

No. 2746C. 50 cts.



No. 2891C. 75 cts.

No. 272B. 35 cts.



No. 2749C. 45 cts.



No. 275B. 50 cts.



No. 278B. 45 cts.

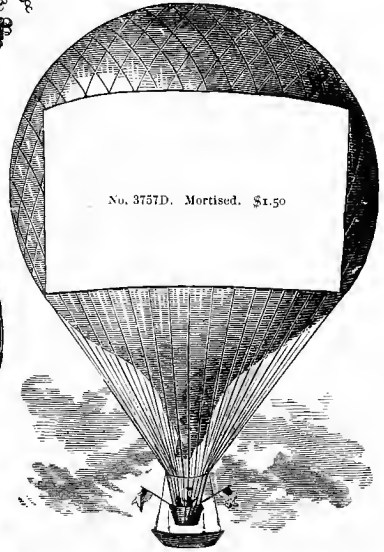

No. 270B. \$1.00

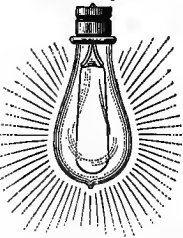

No. 269B. \$1.00



AMERICAN TYPE FOUNDERS COMPANY

No. 1854D \$1.00



No. 276B. 50 cts.



No. 2678C. 75 cts.

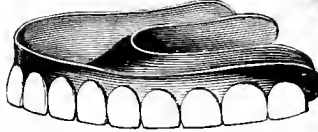

No. 2453C. 40 cts.

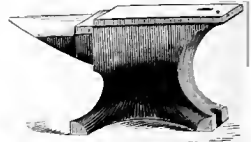

No. 3292C. 30 cts.



No. 170B. 4:c.



No. 2045E. 50 cts.



No. 865E. 30 cts.



No. 2681C. \$1.25



No. 277B. 35 cts.



No. 1294D. 80 cts.

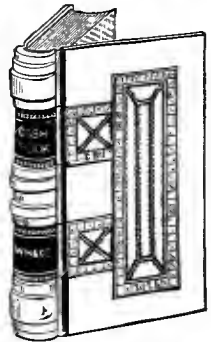

No. 865E. 35 cts.



No. 2125C. 40 cts.



No. 3410C. \$4.00



No. 2253D. 80 cts.

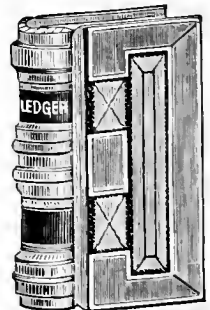

No. 12,178C. 50 cts.



No. 12,176C. 60 cts.

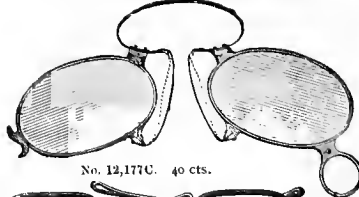

No. 12,177C. 40 cts.



No. 12,179C. 60 cts.



AMERICAN TYPE FOUNDERS COMPANY



No. 3440C. Mortised. 75 cts.

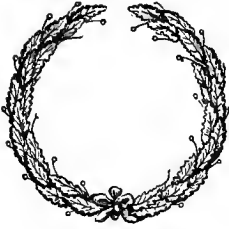

No. 4132C. 50 cts.

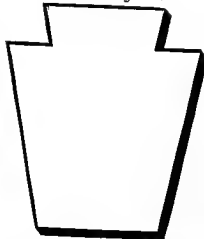

Mortised, extra, 30 cts.

No. 3198C. 40 cts.



No. 3788C. \$1.00

No. 12,181C. 40 cts.



No. 4131C. 40 cts.

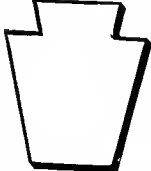

Mortised, extra, 30 cts.

No. 4130C. 35 cts.



No. 4129C. 30 cts.

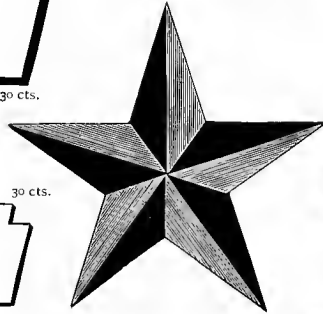

No. 12,180C. 50 cts.

No. 3949C. Mortised. 50 cts.

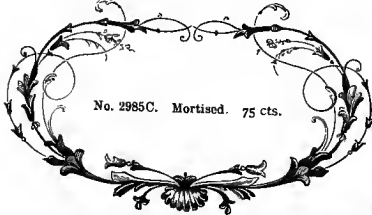

No. 2985C. Mortised. 75 cts.

No. 2044E. 75 cts.

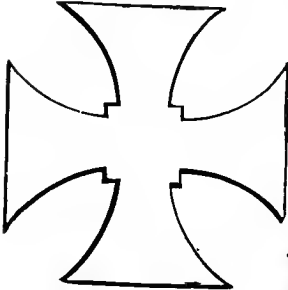

No. 2467C. 50 cts.



No. 3948C. Mortised. 75 cts.



No. 2042E. 45 cts.



No. 3439C. Mortised. 50 cts.



No. 2364C. Mortised. 50 cts.

No. 12,182C. 50 cts.

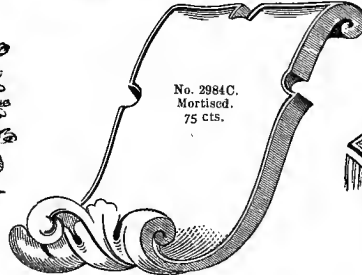

No. 2984C. Mortised. 75 cts.

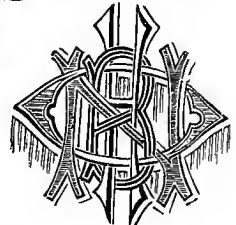

# Miscellaneous Cast Cuts



AMERICAN TYPE FOUNDERS COMPANY

Missing Page

Missing Page

Missing Page

Missing Page

Missing Page

Missing Page



Missing Page

Missing Page

Missing Page

Missing Page

Missing Page

Missing Page

Missing Page

Missing Page



Missing Page

Missing Page

Missing Page

Missing Page

Missing Page

Missing Page

Missing Page

Missing Page



Missing Page

Missing Page

Missing Page

Missing Page

Missing Page

Missing Page

Missing Page

Missing Page



Missing Page

Missing Page

# **WOOD TYPE.**

---

The following series are selected from our Complete Specimen Book of Wood Type, which will be forwarded on application. It contains the most up-to-date, and also all the standard, styles of Wood Type, Borders and Ornaments.

## **SIZES OF FONTS:**

Wood Type is priced by the letter, and sold in various-sized fonts, as under. Orders for less than a font are strictly net; font orders are subject to discount. For schemes of fonts see our Specimen Book of Wood Type.

3A cap font contains 75 letters.

3a lower case font contains 65 letters.

4A cap font contains 106 letters.

4a lower case font contains 90 letters.

5A cap font contains 120 letters.

5a lower case font contains 104 letters.

Figures are put up separately. Each font contains 26 characters, which includes two \$ signs.

---

## **American Type Founders Company**

**COVERING THE CONTINENT.**

## WOOD RULE.

12 cents per yard on side-wood ; 15 cents per foot on end-wood—in assorted lengths. End-wood Rule cannot be supplied in yard lengths. Solid corners to match all sizes, 25 cents per set of four. Wood Rule is sold at a lesser discount than Wood Type.

STYLE W 24 POINT



STYLE U 18 POINT



STYLE R 12 POINT



STYLE N 8 POINT

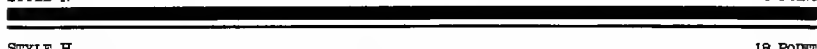

STYLE H 18 POINT



STYLE E 12 POINT



## STAR RULE.

In fonts of 5 feet, with one set of Corners, \$1.90. Star Rule cannot be supplied in yard lengths.

No. 27



No. 23



No. 24





No. 20



## WOOD POINTERS.

A set contains 25 pieces, matching those in our Metal Pointers.

	
2-line Pointers, per set, . . . \$2.00 3 " " " " . . . 2.50 4 " " " " . . . 3.00	5-line Pointers, per set, . . . \$3.50 6 " " " " . . . 4.00 8 " " " " . . . 5.00

For other styles of Wood and Star Rules, see our Complete Specimen Book of Wood Type. Sent on application only.

AMERICAN TYPE FOUNDERS COMPANY

END-WOOD BORDERS.

Kept in stock in 5-foot fonts, with one set of Corners. For a full sheet 10 feet of Border are required.

No. 244

5 FEET WITH CORNERS \$5 40



No. 333

5 FEET WITH CORNERS \$5 40



No. 131

5 FEET WITH CORNERS \$4 20



No. 295

5 FEET WITH CORNERS \$4 20



No. 110

5 FEET WITH CORNERS \$4 20



No. 254

5 FEET WITH CORNERS \$3 60



No. 259

5 FEET WITH CORNERS \$3 60



No. 250

5 FEET WITH CORNERS \$3 60



No. 40

5 FEET WITH CORNERS \$3 60



For a complete assortment of Wood Borders, see our Specimen Book of Wood Type. Sent on application only.

CLASS P

NO. 641. 10-LINE

12 CENTS PER LETTER

**Bands**

CLASS P

NO. 641. 8-LINE

10 CENTS PER LETTER

**Bradley**

CLASS P

NO. 641. 8 LINE

8 CENTS PER LETTER

**Founders 5**

CLASS P

NO. 641. 5-LINE

7 CENTS PER LETTER

**Predominate**

For sizes of fonts, see page 495. For other sizes of above series, see our Specimen Book of Wood Type. Sent on application only.

CLASS O

NO. 642, 10-LINE

10 CENTS PER LETTER

Great

CLASS O

NO. 642, 8-LINE

6 CENTS PER LETTER

Stands

CLASS O

NO. 642, 6-LINE

6 CENTS PER LETTER

Decorate

CLASS O

NO. 642, 5-LINE

6 CENTS PER LETTER

Establish 5

For sizes of fonts, see page 495. For other sizes of above series, see our Specimen Book of Wood Type. Sent on application only.

CLASS O

NO 627, 10-LINE

10 CENTS PER LETTER

Mad

CLASS O

NO 627, 6-LINE

6 CENTS PER LETTER

Colts

CLASS O

NO. 627, 7-LINE

6 CENTS PER LETTER

Break

CLASS O

NO. 627, 6-LINE

6 CENTS PER LETTER

Grants

For sizes of fonts, see page 495. For other sizes of above series, see our Specimen Book of Wood Type. Sent on application only.



CLASS 0

No. 629, 10-LINE

10 CENTS PER LETTER

Backs

CLASS 0

No. 629, 8-LINE

8 CENTS PER LETTER

Hunter

CLASS 0

No. 629, 6-LINE

6 CENTS PER LETTER

Exhibited

CLASS 0

No. 629, 5-LINE

6 CENTS PER LETTER

Celebration

For sizes of fonts, see page 495. For other sizes of above series, see our Specimen Book of Wood Type. Sent on application only.

CLASS O

NO. 189, 10-LINE

10 CENTS PER LETTER

**RID**

CLASS O

NO. 189, 8-LINE

8 CENTS PER LETTER

**DOG**

CLASS O

NO. 189, 8-LINE

6 CENTS PER LETTER

**Bands**

CLASS O

NO. 189, 5-LINE

8 CENTS PER LETTER

**Board 6**

For sizes of fonts, see page 495. For other sizes of above series, see our Specimen Book of Wood Type. Sent on application only.

CLASS N

NO. 231, 10-LINE

10 CENTS PER LETTER

**BISON**

CLASS N

NO. 231, 6-LINE

8 CENTS PER LETTER

**NORMS**

CLASS N

NO. 231, 6-LINE

6 CENTS PER LETTER

**Rancher 3**

CLASS N

NO. 231, 5-LINE

6 CENTS PER LETTER

**Old Banker 5**

For sizes of fonts, see page 495. For other sizes of above series, see our Specimen Book of Wood Type. Sent on application only.

CLASS N

No. 95, 10-LINE

10 CENTS PER LETTER

**ROUND HEADS**

CLASS N

No. 95, 8-LINE

8 CENTS PER LETTER

**BOUNDING HORSE**

CLASS N

No. 95, 6-LINE

6 CENTS PER LETTER

**DUTCHMAN BREECHES**

CLASS N

No. 95, 5-LINE

6 CENTS PER LETTER

**Womens Beautiful Costumes**

For sizes of fonts, see page 495. For other sizes of above series, see our Specimen Book of Wood Type. Sent on application only.

CLASS N

NO. 24, 15-LINE

14 CENTS PER LETTER

**ROBINS**

CLASS N

NO. 24, 10-LINE

10 CENTS PER LETTER

**POINTERS**

CLASS N

NO. 24, 6-LINE

6 CENTS PER LETTER

**NATIONAL SONGS**

For sizes of fonts, see page 495. All sizes complete with caps, lower-case and figures. For other sizes of above series, see our Specimen Book of Wood Type. Sent on application only.

CLASS N

NO. 37, 10-LINE

10 CENTS PER LETTER

**HIDES**

CLASS N

NO 37, 8-LINE

8 CENTS PER LETTER

**DESIGN**

CLASS N

NO. 37, 6-LINE

6 CENTS PER LETTER

**MOTHERS**

CLASS N

NO 37, 5-LINE

6 CENTS PER LETTER

**Side Boards**

For sizes of fonts, see page 495. For other sizes of above series, see our Specimen Book of Wood Type. Sent on application only.

CLASS O

NO. 23 10-LINE

10 CENTS PER LETTER

**DOB**

CLASS O

NO. 23, 8-LINE

8 CENTS PER LETTER

**SUM**

CLASS O

NO. 23, 6-LINE

8 CENTS PER LETTER

**CORES**

CLASS O

NO. 23, 5-LINE

8 CENTS PER LETTER

**MORNS**

For sizes of fonts, see page 495. All sizes complete with caps, lower case and figures. For other sizes of above series, see our Specimen Book of Wood Type. Sent on application only.

CLASS L

NO. 81, 15-LINE

12 CENTS PER LETTER

**SPRUCE**

CLASS L

NO. 81, 10-LINE

9 CENTS PER LETTER

**TIME RUNS**

CLASS L

NO. 81, 8-LINE

6 CENTS PER LETTER

**BRADENBURGH 8**

For sizes of fonts, see page 495. For other sizes of above series, see our Specimen Book of Wood Type. Sent on application only.



CLASS L

NO. 50, 10-LINE

9 CENTS PER LETTER

**HOMER**

CLASS L

NO. 50, 8-LINE

6 CENTS PER LETTER

**GRINDER**

CLASS L

NO. 50, 6-LINE

6 CENTS PER LETTER

**NUMBERED**

CLASS L

NO. 50, 5-LINE

6 CENTS PER LETTER

**Government 4**

For sizes of fonts, see page 495. For other sizes of above series, see our Specimen Book of Wood Type. Sent on application only.

CLASS M

NO. 45, 10-LINE

9 CENTS PER LETTER

**RIDES**

CLASS M

NO. 45, 8-LINE

8 CENTS PER LETTER

**SHINER**

CLASS M

NO. 45, 6-LINE

6 CENTS PER LETTER

**GROUND**

CLASS M

NO. 45, 5-LINE

6 CENTS PER LETTER

**Numerate 5**

For sizes of fonts, see page 495. For other sizes of above series, see our Specimen Book of Wood Type. Sent on application only.

CLASS O

NO 21, 10-LINE

10 CENTS PER LETTER

**DOG**

CLASS O

NO 21, 8-LINE

8 CENTS PER LETTER

**RIMS**

CLASS O

NO 21, 6-LINE

6 CENTS PER LETTER

**HOUSE**

CLASS O

NO 21, 5-LINE

6 CENTS PER LETTER

**SPOKEN**

For sizes of fonts, see page 495. All sizes complete with caps, lower case and figures. For other sizes of above series, see our Specimen Book of Wood Type. Sent on application only.

CLASS P

No. 235, 10-LINE

12 CENTS PER LETTER

*Bert*

CLASS P

No. 235, 8-LINE

10 CENTS PER LETTER

*Sticks*

CLASS P

No. 235, 6-LINE

8 CENTS PER LETTER

*ICE Cost*

CLASS P

No. 235, 5 LINE

7 CENTS PER LETTER

*Avenue 8*

For sizes of fonts, see page 495. For other sizes of above series, see our Specimen Book of Wood Type. Sent on application only.

Missing Page

Missing Page

Missing Page

Missing Page





**Catalogue and  
...Price List...**



**Everything for  
...the Printer...**



**American Type Founders  
... Company ...**

**No. 45 N. Division Street, corner of Ellicott  
BUFFALO, N. Y.**





## FOR THE COMPOSING ROOM.

### BODKINS.



No. 1, wood handle, needle steel, each . \$0 10



No. 2, wood handle, needle steel, each . \$0 10

### TWEEZERS.



This is good and cheap; polished steel; Nonpareil points.

No. 11, nickel-plated, each . \$0 25



This is the best Tweezer procurable at the price; file point, steel, 4 inches long.

No. 5, nickel-plated, each . \$0 50



These are the best made; tempered steel, nickel-plated, file-cut points and backs. No. 7 is 4 inches long; No. 8, 4 3/4 inches long.

No. 7, nickel-plated, 4 inches long, each . \$0 75  
No. 8, nickel-plated, 4 3/4 inches long, each . 0 85



The only Tweezer that can be carried in the pocket with comfort and safety. It locks and unlocks automatically. Hold it points down and press between fingers gently, and it unlocks; hold it points up and bring points together, and it locks securely.

No. 9. Self-locking, nickel-plated, each . \$0 90



No. 3. Combination Tweezer and Bodkin, nickel-plated, each . \$1 00

When Tweezer is in use the Bodkin folds into it. When Bodkin is required, pressure on the file-cut are shown in cut brings it out easily, and when extended it locks securely, and is as firm as an ordinary Bodkin. This is the latest and most satisfactory combination. Patent applied for.

### PAGE CORD.



The real thing. 8-ply Charter Oak Cotton. 3 ounce balls, each . \$0 25

### PRINTERS' EYE SHADE.

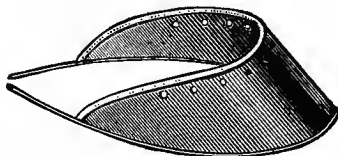

Per dozen . \$1 50  
Each . 0 15

## COMPOSING STICKS.

### THE BUCKEYE.

Quick and easy to set; will not slip; lies flat; as secure as the Common Screw Stick, and easier to set than the Yankee Job Stick.



6 ins. x 2, 2¼ or 2½ ins. deep	\$.90
8 ins. x 2, 2¼ or 2½ ins. deep	1 00
10 ins. x 2, 2¼ or 2½ ins. deep	1 20
12 ins. x 2, 2¼ or 2½ ins. deep	1 40
14 ins. x 2, 2¼ or 2½ ins. deep	1 60
16 ins. x 2, 2¼ or 2½ ins. deep	1 80
20 ins. x 2, 2¼ or 2½ ins. deep	2 20
24 ins. x 2, 2¼ or 2½ ins. deep	2 60

### YANKEE JOB.

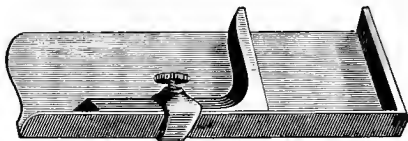

6 ins. x 2, 2¼ or 2½ ins. deep	\$.75
8 ins. x 2, 2¼ or 2½ ins. deep	0 80
10 ins. x 2, 2¼ or 2½ ins. deep	1 00
12 ins. x 2, 2¼ or 2½ ins. deep	1 15
14 ins. x 2, 2¼ or 2½ ins. deep	1 30
16 ins. x 2, 2¼ or 2½ ins. deep	1 45
18 ins. x 2, 2¼ or 2½ ins. deep	1 60
20 ins. x 2, 2¼ or 2½ ins. deep	1 75

### COMMON SCREW.

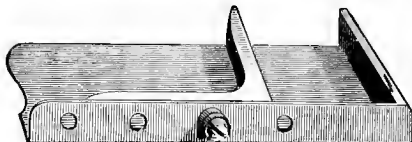

6 ins. x 2, 2¼ or 2½ ins. deep	\$.75
8 ins. x 2, 2¼ or 2½ ins. deep	0 80
10 ins. x 2, 2¼ or 2½ ins. deep	1 00

Other sizes to order at same prices as Yankee Job Sticks.

### THE GROVER.

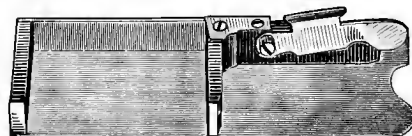

6 x 2¼ inches	\$.90
8 x 2¼ inches	1 00
10 x 2¼ inches	1 20
10½ x 2½ inches (billhead)	1 60
12 x 2¼ inches	1 40
16 x 2¼ inches	1 80

Extra Clasps, 10 cents; extra Knees, 40 cents each.

### "C" SLOT STICK.

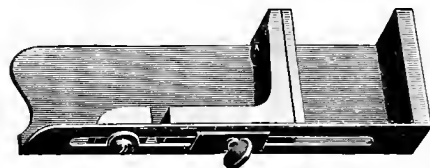

Has two entirely novel features: (1) The inside of face of the knee is adjustable, so that it can be squared up in case the knee wears; (2) The knee is in two sections, so that the Stick can be set to shorter measure without changing the full measure adjustment. See cut, which shows part of the knee at the left set for full measure, while the main part is set to a lesser measure.

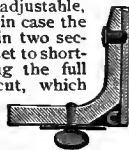

6 ins. x 2¼ ins. deep	\$.15	10 ins. x 2¼ ins. deep	\$.45
8 ins. x 2¼ ins. deep	1 25	12 ins. x 2¼ ins. deep	1 65

### STANDARD JOB COMPOSING STICK.



Sets instantly to Nonpareils or Picas, of the point system only, without the use of leads or quads, and once set cannot possibly slip.

	2 ins.	2¼ ins.	2½ ins.
6 inches	\$1 75	\$1 85	\$1 95
8 inches	2 00	2 10	2 20
10 inches	2 25	2 35	2 45
12 inches	2 50	2 60	2 70

PERFECT NEWS STICKS.

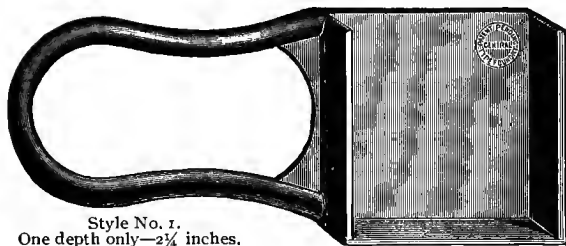

Style No. 1.  
One depth only— $2\frac{1}{4}$  inches.

These Sticks are made for setting one measure only, either 13 or  $13\frac{1}{2}$  ems Pica, and prevent all the annoyances due to variations in Sticks set inaccurately by careless compositors. It is undoubtedly the best Stick made for news measures.

Style No. 1 is made of best malleable iron; the handle and under side are japanned, so that the Stick cannot rust; the pan itself is milled out,

the sides being absolutely square and rigid, and altogether the Stick is as perfect as could be desired. Made one depth— $2\frac{1}{4}$  inches—only, and for 13 or  $13\frac{1}{2}$  ems Pica measure.

Style No. 2 is made of the best of steel, and the set bar or knee is riveted firmly to bottom and back of Stick. It is accurate in every respect.

These Sticks are made for 13 or  $13\frac{1}{2}$  ems Pica measure, and are  $2\frac{1}{4}$  inches deep.

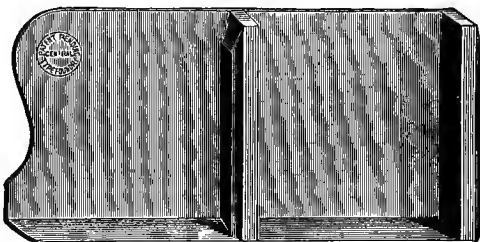

Style No. 2.

- |   |        |
|---|--------|
| No. 1. Malleable Iron, milled, for 13 or $13\frac{1}{2}$ ems Pica measure . . . . . | \$0 75 |
| No. 2. Steel-riveted, for 13 or $13\frac{1}{2}$ ems Pica measure . . . . .          | 0 80   |

WOODEN POSTER STICK.



With brass-lined ends, iron knee and screw clamp.

- |                     |        |
|---------------------|--------|
| 16 inches . . . . . | \$1 00 |
| 20 inches . . . . . | 1 10   |
| 24 inches . . . . . | 1 20   |
| 30 inches . . . . . | 1 35   |
| 36 inches . . . . . | 1 50   |
| 42 inches . . . . . | 1 80   |

COMPOSING AND MAKE-UP RULES.

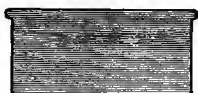

Steel Composing Rules, 15 ems and under, each . . . . . \$0 25

Add 5 cents to above from 15 to 20 ems, and 10 cents extra from 20 to 25 ems.

Nickel plating, 15 cents extra.

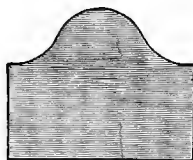

Steel Make-up Rules, 15 ems and under, each . . . . . \$0 30

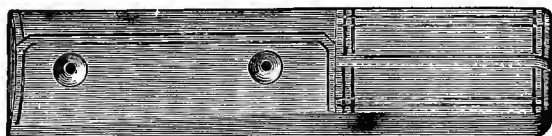

Set of 12 Steel Composing Rules, in leather case . . . . .

\$1 50

**COMPOSING STICK RACK.**

This Rack holds twelve Sticks, and can be attached to the wall or any other convenient place. The Sticks are held securely, and are preserved from the damage liable to them when "kicking about."

Each . . . . . \$1 50

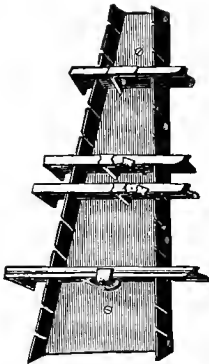

**KELSEY COPY HOLDER.**

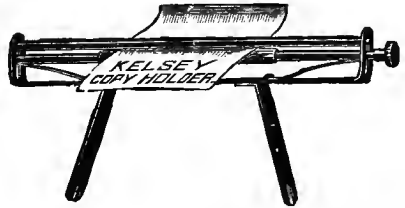

Price, each . . . . . \$0 75

**BRASS LABEL HOLDER.**



The utility of these Label Holders is apparent at a glance, especially when extra men are put on, as it enables them to locate the type quickly.

Size, 1x5½ inches, per hundred, with cards and tacks complete . . . \$2 75  
 Size, 1x5½ inches, per dozen (least quantity sold), complete . . . 0 50

Other sizes furnished to order.

**TYPE MEASURES.**

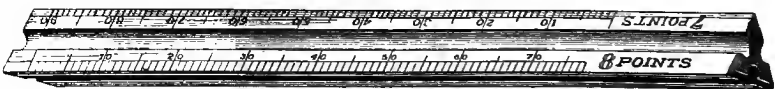

Boxwood Triangular Type Measure.

Boxwood, triangular shape, the best, 9 inches . . . \$1 50  
 Boxwood, triangular shape, the best, 18 inches . . . 3 00

This Type Measure is superior to any, and is guaranteed to be accurate. The sides of the triangle are grooved, so that it is easily handled. It will measure any size from 5½ Point to 18 Point, and all multiples of 6 Point.

Square Brass-Edged Wooden Type Scale, No. 120 . . . \$0 30

Measures 5½, 6, 7, 8, 9, 10, 11 and 12 Points, and has 12-inch scale.

Patent 12-inch Cardboard Type Scale . . . \$0 25

Measures 4½, 5, 5½, 6, 7, 8, 9, 10, 11, and 12 Points, and has 12-inch scale.

Lincoln Type Measure, steel tape, 24 inches long, in German silver case, each . . . \$2 00

Measures 376 lines of Agate (14 lines to the inch); 288 of 6 Point; 246 of 7 Point; 216 of 8 Point; 192 of 9 Point; 172 of 10 Point; 157 of 11 Point; 144 of 12 Point, and has a 24-inch scale, all plainly marked.

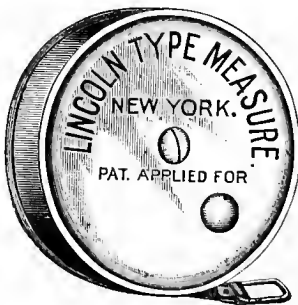

Exact size.

**WOODEN MALLETS.**

Made of thoroughly seasoned and selected stock; handles screwed in; finished in oil; attractive shape. The Lignumvitæ Mallets can be specially recommended. They are heavier than Hickory Mallets, and wear like iron.

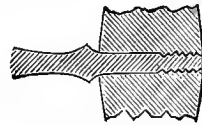

Shows Handle screwed in.

Hickory, small, 2½ × 4½ . . . . .	\$0 25	Lignumvitæ, 2¼ × 3½ . . . . .	\$0 50
Hickory, medium, 3 × 5 . . . . .	0 30	Lignumvitæ, 3 × 5 . . . . .	0 60
Hickory, large, 3½ × 6 . . . . .	0 40	Lignumvitæ, 3½ × 5½ . . . . .	0 75

**IRON BOUND WOODEN MALLET**

. . . . . 1 00

**PATENT RAWHIDE MALLETS.**

This mallet is made entirely of rolled rawhide, except handle, which is of wood.

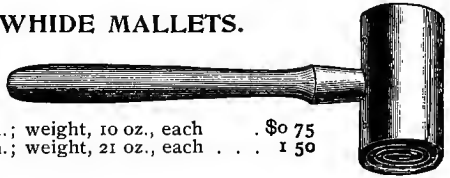

No. 4. Diameter, 2 in.; length, 3¼ in.; weight, 10 oz., each . . . . .	\$0 75
No. 5. Diameter, 2¾ in.; length, 4¼ in.; weight, 21 oz., each . . . . .	1 50

**RAWHIDE-RUBBER MALLET.**

The striking parts of mallet are of rawhide, held by an iron body piece. The iron piece is covered with rubber as a protection to the type in case the mallet falls on, or is laid on, the form. When the rawhide striking parts (or faces) wear out, new faces can be inserted in the iron body piece.

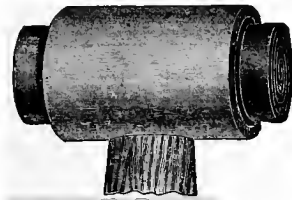

No. 2. Diameter of face, 1½ in., each . . . . .	\$1 25
Extra Rawhide Faces, per pair . . . . .	0 40

**PLANERS.**

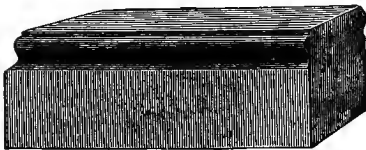

Maple, small, 3 × 6 . . . . .	\$0 25
Maple, large, 3½ × 8 . . . . .	0 30
Maple, leather top, 3½ × 8 . . . . .	0 40

**PROOF PLANERS.**

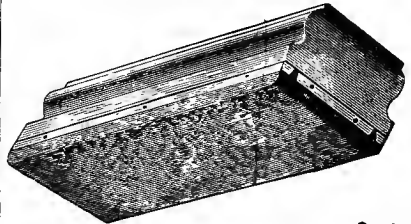

3½ × 8 . . . . .	\$0 60
------------------	--------

**LINOTYPE PLANER.**

The Linotype Planer has a corrugated rubber face and is used for removing the burr from linotype slugs.

Price, each . . . . .	\$0 50
-----------------------	--------



**PRINTER'S DIVIDERS.**

Always useful in laying out margins and distances, imposing plate forms, etc. A great time saver.

Price, each . . . . . \$0 85



**MITER BOXES.**



Wood, 13½ ems wide, each . . . \$0 40  
 Wood, 3 inches wide, each . . . 0 50  
 Iron, each . . . . . 2 50

**SAW.**

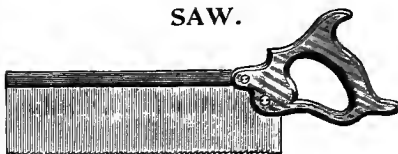

Back Saw, for cutting wood or soft metal. . . . . \$1 25

**BELLOWS.**

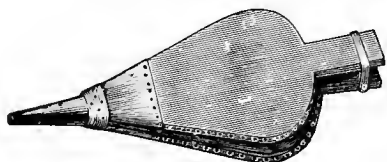

These Bellows are correct in shape, and strongly made of the best materials.

Small size . . . . . \$1 00  
 Large size . . . . . 1 25

**LEADER BOXES.**

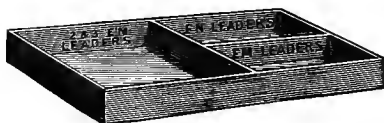

Just "the thing" for holding leaders. The size is 5x8. 1¼ inches.

Price, per dozen . . . . . \$2 50  
 Each . . . . . 0 25

**KEYSTONE HACK SAWS.**



For Sawing Brass,  
 Steel or Other Metals.

The saw blade is secured to the iron frame by two pins, and may be detached easily. When worn it is cheaper to put in a new blade than to refile. One dozen extra blades are furnished with each frame. This is a useful tool in any printing office for cutting thick brass rules, iron side sticks, etc.

Eight-inch Keystone Hack Saw, polished frame, with one dozen saw blades . . . \$1 50  
 Extra blades, eight-inch, per dozen . . . . . \$1 00

**SHOOTING STICKS.**



No. 3, wrought steel, nickel-plated, large, each. . . . \$0 75

No. 2, wrought steel, nickel-plated, small, each. . . . 0 60



Malleable iron, japanned, each . . . . . 0 30



Hickory Shooting Stick, per dozen, 85 cents. . . . each, 0 08



**LITTLE GIANT LEAD AND RULE CUTTERS.**

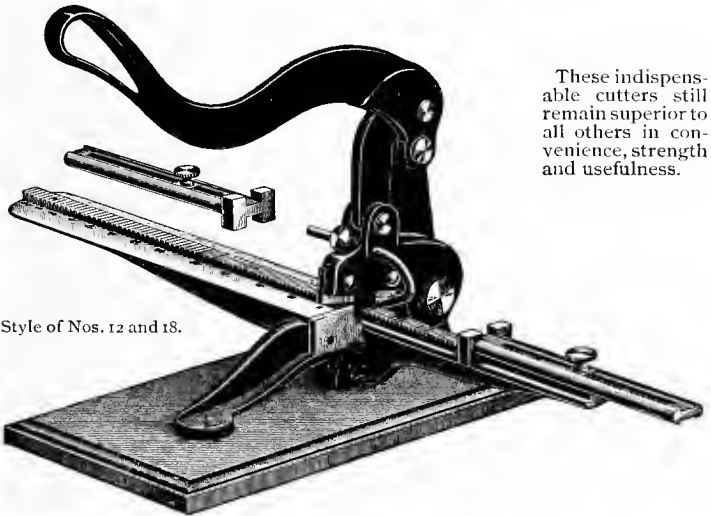

Style of Nos. 12 and 18.

These indispensable cutters still remain superior to all others in convenience, strength and usefulness.

This cut illustrates the latest improvements in these well-known cutters.

Nos. 1 and 3 are the well-known original Little Giants. No. 1 has single, and No. 3 double lever connections. Nos. 12 and 18 have accurate graduated beds and gauges at both front and back of knife, the front gauge being specially designed for cutting leads and rules rapidly, and is so constructed that the cut lead or brass drops off the bed without handling.

No. 1, gauges, 12 inches . . . . .	\$8 00
No. 3, gauges, 18 inches (extra strong) . . . . .	12 00
No. 12, gauges, 12½ inches at back and 11½ inches at front, graduated to Picas . . . . .	10 00
No. 18, gauges, 18½ inches at back and 14 inches at front, graduated to Picas . . . . .	14 00

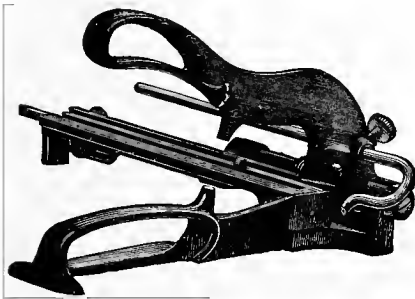

**NONPAREIL LEAD CUTTER.**

Will cut leads and slugs six points thick, and, although not recommended as a rule cutter, will cut two-point brass rule. Has back and front gauges.

Leads can be cut very rapidly and easily on this cutter by holding the lever and the hand-hold on frame in right hand, as in using hand shears. To get the best results this cutter should be screwed to bench or table.

Price . . . . . \$4 00

**UTILITY LEAD CUTTER.**

The strongest cheap Lead Cutter made. A reliable, cheap tool.

Price . . . . . \$2 00

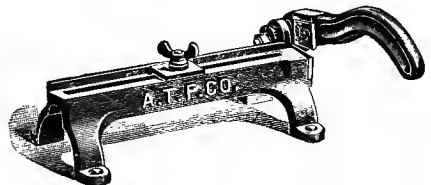

## PATENT UPRIGHT MITER MACHINE.

A strong, well-built, accurate machine. The cutting or shaving head has a positive up and down motion, and must cut as much at the bottom as at the top, as it cannot slip. The knife is regulated by set-screw. The sliding gauge is the best of its kind, enabling the operator to feed the rule up to the knife, but affords a positive check at the point where the desired length is reached. The bed is graduated, and is made movable, so that the whole cutting-edge of knife can be used. This machine is mounted in a strong, shallow, wooden box, which catches the shavings, and has at the front end an emery board on which the burr of the rules may be rubbed off.

With Sliding Gauge . . . . . \$13 00  
 With Micrometer Point-System  
 Gauge . . . . . 20 00

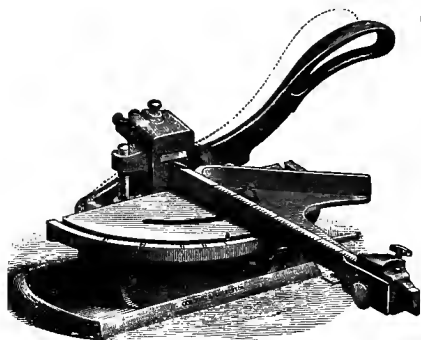
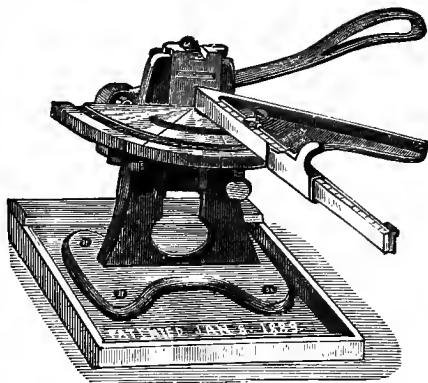

## GOLDING UPRIGHT MITERER.

This machine differs in principle from the Patent Miterer (described on this page) in this: the rule is held stationary, and the knife is fed up to it, while in the Patent Miterer the knife is stationary and the rule is fed to it. The knife of the Golding Miterer is movable, but it is pivoted in such a way as to enable it to make a positive downward cut the same at the bottom as at the top. The knife adjustment is specially good. The bed is graduated and is made movable, so that the whole cutting-edge of the knife may be used.

Price, boxed . . . . . \$14 00

## LITTLE GIANT RULE SHAPER.

The rule is held flat on the bed by the clamp (2). The gauge (5) is graduated to Picas by notches, and is regulated by the pointer (4), which engages in the notches. Five steel cutting tools of different angles are furnished with each machine. The cutting tool is held in the head (1). By turning the wheel the cutter is moved back and forth over the rule, sinking deeper at each cut, and when it completes the cut it is lifted automatically, ready for the next cut. If the rule is thinner than 12 Points, the head (1) may be brought down to the rule by moving the lever (3). Any thickness of rule up to 12 Point may be mitered. At each cut both sides of the miter are made, and join without further trimming. This machine is not designed for trimming the ends of leads and rules, and therefore does not supersede the upright miterer; but in offices where much mitering is done it will prove a time and rule saver, as it miters very rapidly.

*Send for illustrated circular.*

Price . . . . . \$35 00  
 Patent graduated gauge, extra . . . . . 4 00

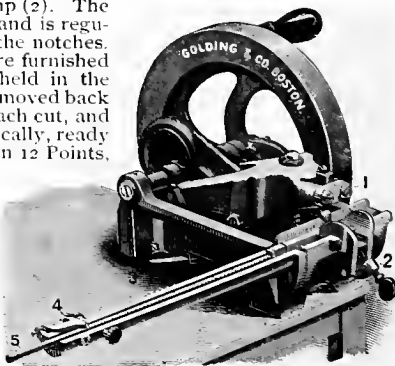

### GOLDING RULE-CURVING MACHINE.

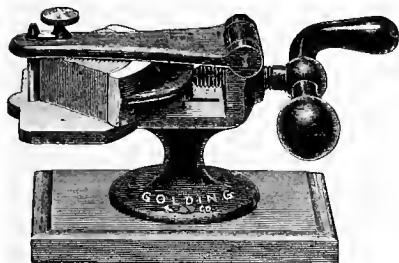

This machine curves brass rule from one-quarter inch to eight inches in diameter by pressure exerted by the screw on curved brass plates, between which the rule is put at the proper place to get the required curve, as indicated by a scale engraved on the bed. Smaller curves can be made on this machine than on any other. An attachment is supplied for forming square corners as a substitute for mitered corners. Brass rule for curving or bending should be annealed. All brass rule made by us can be annealed to order at a slight extra charge.

- No. 1, curves one-quarter to four inches diameter .
  - No. 2, curves three-eighths to eight inches diameter
- Dies for forming square corners, per set .

. \$12 00  
 . 18 00  
 1 50

### PRINTERS' CURVING MACHINE.

On this machine the curves are made by pressure between three iron rollers (two below and one on top), and the pressure is regulated by the screw at left hand side, which acts on a lever that raises or depresses the lower iron rollers. The action is very rapid, and, in the hands of an expert, accurate.

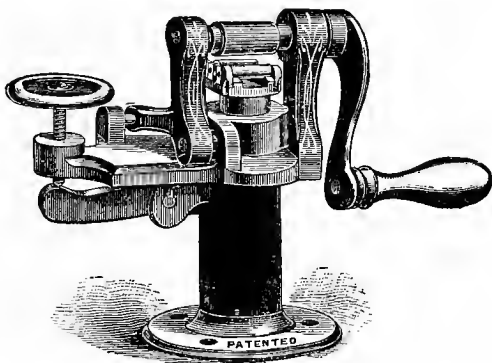

Price . . \$15 00

### ELITE RULE BENDER.



The blade is tool steel and the cylinders of brass. Bends rule from one to six points in thickness. The end of the rule is firmly held in the grooves in cylinder, and can be twisted into any shape.

Price, with instructions for rule bending .

. \$2 00

### PLIERS.

For Bending Brass Rule.

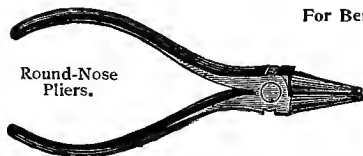

Round-Nose Pliers.

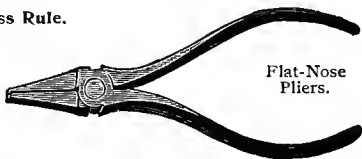

Flat-Nose Pliers.

Six-inch Round or Flat-Nose Pliers, polished, each .

. \$0 50

**SMOOTH-LINED BRASS GALLEYS.**

Inside they are perfectly smooth and free from screws. The lining is angle brass, and is soldered to the bottom plate, strengthening the sides, and protecting the wood rim from the action of lye and water. The head is supported by a strong strip of brass.

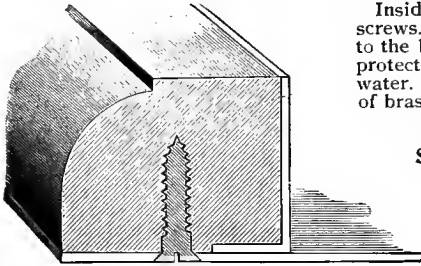

Sectional end view, showing how the brass lining protects the wood rim from action of lye and water.

**SMOOTH-LINED JOB GALLEYS.**

6	× 10 inches inside .	\$2 00
8 $\frac{3}{4}$	× 13 inches inside .	2 50
10	× 16 inches inside .	3 00
12	× 18 inches inside .	3 50
14	× 20 inches inside .	4 00
15	× 22 inches inside .	5 00
18	× 25 inches inside .	5 75

**SMOOTH-LINED COLUMN GALLEYS.**



Smooth-lined Column Galley, showing Brass Plate at Head.

Single Column, brass-lined,	3 $\frac{1}{2}$ × 23 $\frac{1}{4}$ inches inside	\$2 00
Single Column, brass-lined,	3 $\frac{1}{2}$ × 11 $\frac{3}{4}$ inches inside	1 50
Medium width, brass-lined,	4 $\frac{1}{4}$ × 23 $\frac{1}{4}$ inches inside	2 25
Double Column, brass-lined,	6 $\frac{1}{4}$ × 23 $\frac{1}{4}$ inches inside	2 50
Triple Column, brass-lined,	8 $\frac{1}{2}$ × 23 $\frac{1}{4}$ inches inside	3 00
Single Column, half-lined,	3 $\frac{1}{2}$ × 23 $\frac{1}{4}$ inches inside	1 75
Double Column, half-lined,	6 $\frac{1}{4}$ × 23 $\frac{1}{4}$ inches inside	2 25

**PATENT-LINED GALLEYS.**



Fig. 1.

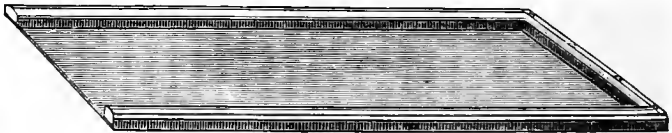

Fig. 2.

The wood rim has a brass lining driven into it, as illustrated in Fig. 1, thus avoiding the use of screws. The wood rims are secured to the bottom by screws.

**PATENT-LINED COLUMN GALLEYS.**

	Size inside.	Full-lined.	Half-lined.
Single Column .	3 $\frac{1}{4}$ × 23 $\frac{1}{4}$	\$2 00 .	\$1 75 .
Medium Column . .	5 × 23 $\frac{1}{4}$	2 25 .	2 00 .
Double Column	6 $\frac{1}{4}$ × 23 $\frac{1}{4}$	2 50 .	2 25 .

**PATENT-LINED JOB GALLEYS.**

6 × 10 inches inside .	\$1 50	12 × 18 inches inside .	\$3 75
8 $\frac{3}{4}$ × 13 inches inside .	2 00	14 × 21 inches inside .	4 50
9 × 14 inches inside .	2 50	15 × 22 inches inside .	5 00
10 × 16 inches inside . . . . .	3 00	18 × 25 inches inside . . . . .	6 00

SUCCESS RIVETED ALL-BRASS GALLEYS.



Made of heavy brass, the sides riveted strongly to the bottoms, and the corners locked together by a patented hold, which effectually resists all the strain of locking-up. These galleys will be found to be a great improvement over those galleys with bottoms screwed to the sides. The list prices remain the same as charged for



Shows method of securing sides to bottom by rivets.



Shows patent corner hold.

galleys with bottom secured by screws. These galleys have been the standard for quality and construction for several years, and are still unexcelled.

ALL-BRASS COLUMN GALLEYS.

Single, $3\frac{3}{4} \times 23\frac{3}{4}$ inches inside . .	\$2 00	Double, $6\frac{1}{4} \times 23\frac{3}{4}$ inches inside . .	\$2 50
Single, $3\frac{3}{4} \times 11\frac{3}{4}$ inches inside	1 50	Triple, $8\frac{1}{4} \times 23\frac{3}{4}$ inches inside	3 25
Medium, $5 \times 23\frac{3}{4}$ inches inside	2 25		

ALL-BRASS JOB GALLEYS.

6 $\times$ 10 inches inside . .	\$1 50	12 $\times$ 18 inches inside . .	\$3 75
8 $\frac{1}{2}$ $\times$ 13 inches inside	2 00	14 $\times$ 21 inches inside	4 50
9 $\times$ 14 inches inside	2 50	15 $\times$ 22 inches inside	5 00
10 $\times$ 16 inches inside	3 00	18 $\times$ 25 inches inside	6 00

LINCOLN ALL-BRASS GALLEYS.

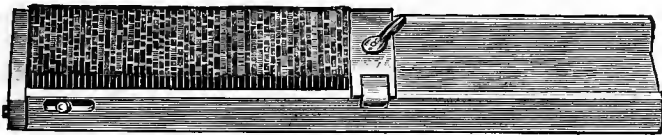

Shows the Galley locked at end and side.

A good galley for newspaper work. *Made to order* to hold any regular widths of matter in regular use in an office. The upper side or rim of galley is strongly hinged to the bottom.

This hinged side is dropped when emptying on galley, and when matter is ready for locking up the side is raised and is held by a spring-catch at head of galley

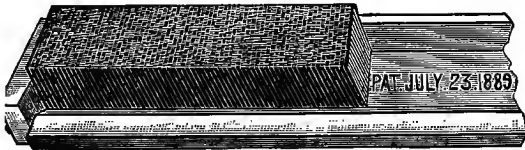

Shows the Galley unlocked, with end lock detached.

and by the end clamp which locks the sides and end at the same operation. The catch is loosened by turning lever to the right. These galleys are about one inch wider than the width of column they are made to take.

12-inch News, all brass . . . . .	\$2 00	24-inch News, all brass . . . . .	\$3 00
16-inch News, all brass . . . . .	2 50	24-inch Book, all brass . . . . .	3 50

In ordering, give exact width of columns.

## LAING PATENT GALLEY LOCK-UP.

Attachable to all Brass, Smooth Lined, and Patent Lined Gallies.

A satisfactory, simple, effective lock-up. It may be screwed on any galley; the side-stick (which is not beveled) is attached to the lock-up, and has a parallel motion. It is locked or unlocked by pushing the lever up or down by means of a finger knob. The lock-up and the side-stick are made of brass.



### \* COLUMN GALLEYS, WITH LOCK-UP.

	Price of Galley.	*Price of Lock-up.	Complete.
3¼ × 23¼ inches inside .	\$2 00	\$1 50	\$3 50
3¼ × 15¼ inches inside .	1 75	1 40	3 15
3¼ × 11¼ inches inside .	1 50	1 30	2 80
5 × 23¼ inches inside .	2 25	1 50	3 75
6¼ × 23¼ inches inside .	2 50	1 50	4 00
6¼ × 15¼ inches inside .	2 25	1 40	3 65
6¼ × 11¼ inches inside .	2 00	1 30	3 30
8¼ × 23¼ inches inside .	3 25	1 50	4 75

### \* JOB GALLEYS, WITH LOCK-UP.

	Price of Galley.	*Price of Lock-up.	Complete.
6 × 10 inches inside .	\$1 50	\$1 25	\$2 75
8¼ × 13 inches inside .	2 00	1 30	3 30
9 × 14 inches inside .	2 50	1 35	3 85
10 × 16 inches inside .	3 00	1 40	4 40
12 × 18 inches inside .	3 75	1 45	5 20
14 × 21 inches inside .	4 50	1 50	6 00
15 × 22 inches inside .	5 00	1 50	6 50
18 × 25 inches inside .	6 00	1 60	7 60

\*If Galley Lock-up is sold separately, the necessary screws for attaching to galley are included in prices given.

## PATENT LINOTYPE GALLEY.

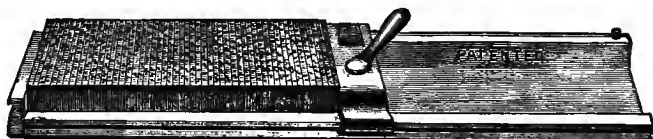

This new patent galley is made solely for linotypes, and is the only galley for holding linotype slugs without any side lock-up. A foot clamp is attached to each galley to hold up the matter in taking proofs. This galley will save all the trouble and the loss of time in handling side-sticks, getting quoins to fit, or foot slugs to keep the end line from falling over. One side of the galley is made lower, and the inside of the rims so tapered as to allow inserting and taking out the linotype slugs from the side very readily. The galley being only one-half of an inch wider than the matter, is conveniently handled and can be placed on the stone, rack or case without taking

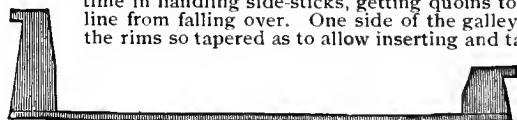

End view, 13 ems wide inside.

up valuable space. On a crowded imposing table, in the rush of making-up, the saving of space is of great importance.

12 inch, all-brass News Galley, for 16 ems or under †.	\$2 00
16 inch, all-brass News Galley, for 16 ems or under	2 25
24 inch, all-brass News Galley, for 16 ems or under	2 50
Extra foot clamps, each .	0 50

Other sizes made to order. Above prices include foot clamp.

† In ordering, give the measure of column width, as galleys are supplied to take one measure only, not exceeding 16 ems; also send a sample linotype slug.

**UNLINED GALLEYS.**

**ZINC BOTTOM.**

Single Column,  $3\frac{1}{4} \times 23\frac{1}{8}$  inches inside . . . . . \$1 25  
 Double Column,  $6\frac{1}{4} \times 23\frac{1}{8}$  inches inside . . . . . 1 50

**BRASS BOTTOM.**

Single Column,  $3\frac{1}{4} \times 23\frac{1}{8}$  inches inside . . . . . \$1 50  
 Double Column,  $6\frac{1}{4} \times 23\frac{1}{8}$  inches inside . . . . . 2 00

**CLOSED-END MAILING GALLEYS.**



$6\frac{1}{4} \times 23\frac{1}{2}$  inches inside, closed ends, all brass, each . . . . . \$3 25  
 $7\frac{1}{4} \times 23\frac{1}{2}$  inches inside, closed ends, all brass, each . . . . . 3 50  
 $6\frac{1}{4} \times 22\frac{1}{4}$  inches inside, closed ends, brass lined, each . . . . . 3 00  
 $10 \times 22\frac{1}{4}$  inches inside, closed ends, brass lined, each . . . . . 4 00  
 $2\frac{7}{8} \times 24$  inches inside, closed ends, brass lined, each . . . . . 2 25  
 $6\frac{1}{4} \times 22\frac{1}{4}$  closed ends, zinc bottom, unlined, each . . . . . 1 50

**MAILING GALLEYS.**



Mustang Mailing Galley.

Mustang Mailing Galley, zinc bottom . . . . . \$0 50  
 Mustang Mailing Galley, brass bottom . . . . . 0 75



Rukenbrod Mailing Galley.

Rukenbrod Mailing Galley, zinc bottom . . . . . \$0 60  
 Rukenbrod Mailing Galley, brass bottom . . . . . 0 85

**WOODEN GALLEYS.**



5 × 8 inches inside . . . . . \$0 25	8 × 10 inches inside . . . . . \$0 40
5 × 15 inches inside . . . . . 0 30	8 × 24 inches inside . . . . . 0 60
$5\frac{1}{2} \times 18$ inches inside . . . . . 0 40	10 × 16 inches inside . . . . . 0 65
6 × 10 inches inside . . . . . 0 30	9 × 18 inches inside . . . . . 0 70
$6\frac{1}{4} \times 24$ inches inside . . . . . 0 60	10 × 24 inches inside . . . . . 0 75
7 × 22 inches inside . . . . . 0 55	$3\frac{1}{2} \times 24$ inches inside . . . . . 0 50

MOVABLE GALLEY RACKS.

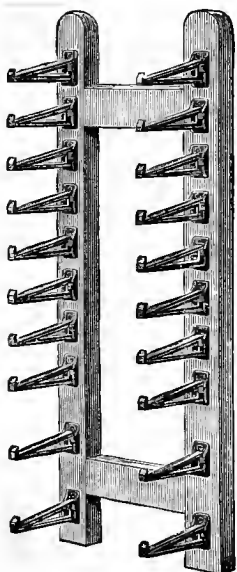

Regular Galley Rack with Movable Galley Brackets.

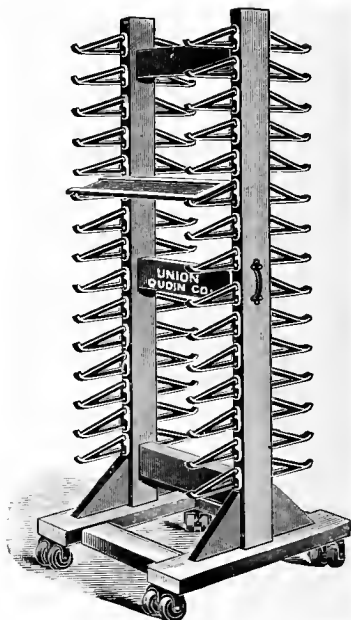

Union Movable Galley Rack.

UNION MOVABLE GALLEY RACK.

The Union Movable Galley Rack holds 30 galleys, and is mounted on strong casters so that it can be moved at will to the most convenient position for doing the work in hand. Union Movable Galley Rack, holds 30 galleys . . . . . \$21 00

REGULAR GALLEY RACK.

The Regular Galley Rack is intended for placing against the wall. The brackets are secured on a very strong hard-wood frame.

Regular Galley Rack, for 6 galleys	. . . . .	\$ 3 00
Regular Galley Rack, for 8 galleys	. . . . .	4 00
Regular Galley Rack, for 10 galleys	. . . . .	5 00
Regular Galley Rack, for 12 galleys	. . . . .	6 00
Regular Galley Rack, for 15 galleys	. . . . .	7 50
Regular Galley Rack, for 20 galleys	. . . . .	10 00

GALLEY BRACKETS.

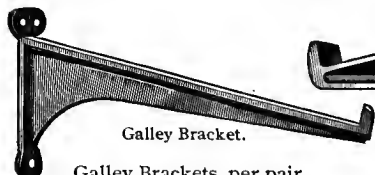

Galley Bracket.

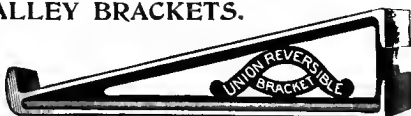

Union Reversible Galley Bracket and Socket.



Galley Brackets, per pair . . . . .		\$0 40
Union Reversible Galley Brackets, with sockets, per doz. pairs, \$6 00; per pair .		0 60



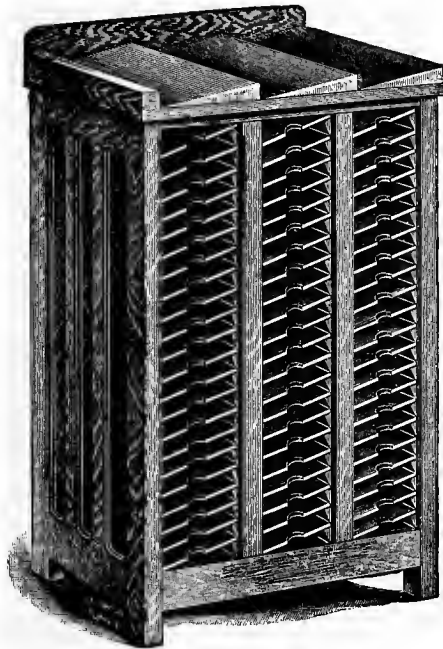

Three-tier Galley Cabinet with Galley Top,  
to hold Sixty-six Gallies.

## GALLEY CABINETS.

Made in Hard Wood, Cherry Finish.

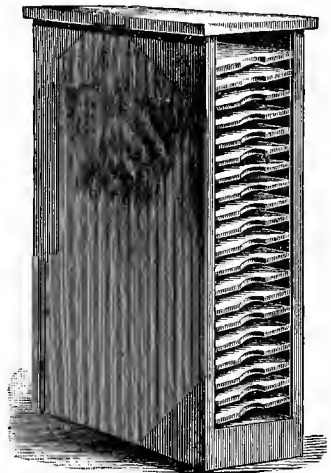

One-tier Flat-top Galley Cabinet,  
to hold Twenty Gallies.

Particular attention is directed to the Galley Cabinets of larger capacity. They are very desirable in the larger offices, and are designed to carry an immense weight of type safely. All these Cabinets are made of hard wood. All Flat-top Cabinets are made same style as the One-tier Cabinet illustrated above. All Galley-top Cabinets same as the Three-tier Cabinet shown on this page.

The "Galley-top" Cabinets are of much stronger construction than the "Flat-top," and may be ordered with or without galley top, as desired, at the same prices.

	With Flat Top.	With Galley Top.	Boxing.
1 Tier to hold 20 Gallies . . . . .	\$ 8 00	\$14 00	\$0 50
1 Tier to hold 30 Gallies . . . . .	11 50	. . .	0 75
2 Tier to hold 40 Gallies . . . . .	15 00	25 00	1 00
2 Tier to hold 50 Gallies . . . . .	18 50		1 25
2 Tier to hold 60 Gallies . . . . .	22 00		1 50
3 Tier to hold 66 Gallies . . . . .		36 00	2 00
4 Tier to hold 88 Gallies . . . . .		47 50	2 50
6 Tier to hold 132 Gallies . . . . .		62 00	3 00
9 Tier to hold 198 Gallies . . . . .		85 00	4 00

NOTE.—The shelves in the larger cabinets should be numbered, and the proof of the galley should be numbered to correspond with the number on shelf, thus saving all the time required to locate galleys that are not so numbered. Iron number plates, made for numbering shelves, can be supplied at the following prices, net: 1 tier (20 galleys), \$1 00; 1 tier (30 galleys), \$1 25; 2 tiers (40 galleys), \$1 50; 2 tiers (50 galleys), \$1 75; 2 tiers (60 galleys), \$2 00; 3 tiers, \$2 25; 4 tiers, \$3 00; 6 tiers, \$4 00; 9 tiers, \$5 00.

**HEMPEL IMPROVED QUOIN.**

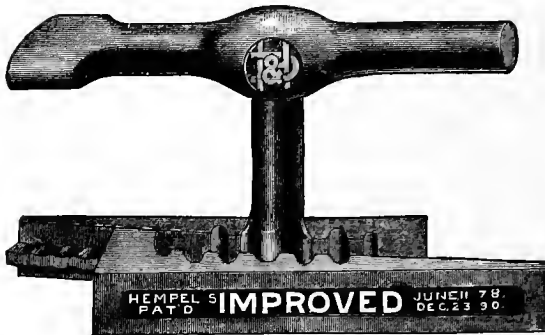

The Hempel Quoins are the standard, tested by time and approved by those who use them. This is the latest improved quoin.

No. 1, small, per dozen pairs . . . . .	\$2 50
No. 2, large, per dozen pairs . . . . .	3 00
Keys, each . . . . .	0 50

**IMPROVED BROWER QUOIN.**

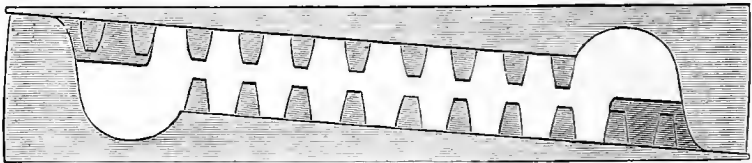

No. 2 Brower Quoin, actual size.

Has central racks, and consequently will not throw type off its feet. Works smoothly. The key, of steel, with cut teeth, has a firmer and deeper hold than in the old style quoin.



No. O. "Little Samson," actual size.

The No. O, as illustrated, is the smallest wedge quoin ever made, and will prove very valuable for job printers and on occasions when lock-up must be made in small spaces.

No. O, smallest wedge quoin made, "Little Samson," per dozen . . . . .	\$2 00
No. 1, medium size, per dozen . . . . .	2 50
No. 2, large size, per dozen . . . . .	3 00
Steel keys, all sizes, each . . . . .	0 50

	Per Dozen.	Key.
<b>WICKERSHAM QUOIN . . . . .</b>	<b>\$2 50</b>	<b>\$0 50</b>
<b>PERRY QUOIN . . . . .</b>	<b>2 50</b>	<b>0 50</b>
<b>CHALLENGE HEMPEL QUOIN, No. 1 . . . . .</b>	<b>2 50</b>	<b>0 50</b>
<b>CHALLENGE HEMPEL QUOIN, No. 2 . . . . .</b>	<b>3 00</b>	<b>0 50</b>

UNION LOCKABLE QUOIN.

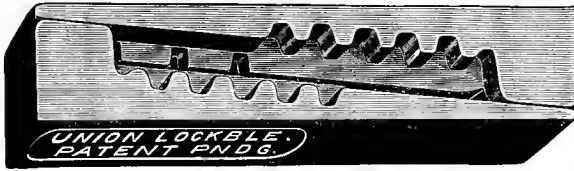

An exact duplicate of the original Hempel Quoin, with three notches cut in the central rib for the purpose of using the quoin in connection with the Patent Brower Lock, listed below.

No. 1, small, per dozen . . . . . \$2 50 | No. 2, large, per dozen . . . . . \$3 00  
 Keys, each . . . . . \$0 50

BROWER QUOIN LOCK.

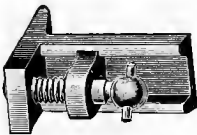

Fig. 2. The Lock.

The sidewise projection shown in Fig. 2 engages in notches cut in central rib of Union Lockable Quoin, or in the rack teeth of the Brower Quoin (see opposite page). The screw is then set up against the other half of the quoin, effectually preventing it from slipping. Quoins of the wedge principle are all liable on long runs to be loosened by the vibrations of the press. These locks make the lock-up doubly sure. They should be applied by the pressman after he has completed the make-ready and before the run is commenced.

No. 0, to fit No. 0 Brower Quoin, per dozen . . . . . \$2 50  
 No. 1, to fit No. 1 Brower Quoin, per dozen . . . . . 2 75  
 No. 2, to fit No. 2 Brower Quoin, per dozen . . . . . 3 00  
 No. 3, to fit No. 1 Union Lockable Quoin, per dozen . . . . . 2 75  
 No. 4, to fit No. 2 Union Lockable Quoin, per dozen . . . . . 3 00  
 Screw-driver, to fasten quoin lock, each . . . . . 50

MIDGET SAFETY QUOIN.

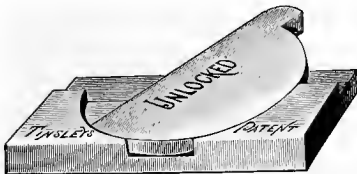

Fig. 3 shows Midget Quoin unlocked.

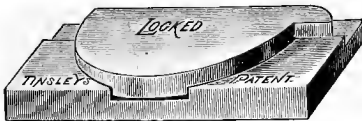

Fig. 2. This cut shows extreme expansion of six points when locked.

Midget Quoins are made of hard brass. Midget Quoins give a safe lock-up in a width of 18 points. Midget Quoins are useful for locking a form within a form.

It is locked by a tap of a mallet, and occupies no more space in length when locked than when unlocked.

Can be used in a space 18 points wide by 120 points long, either outside or inside a form. It is absolutely safe, as when locked it rests against its corresponding flat surfaces, and the harder the surface it bears against the better.

This invaluable quoin may be used to lock up matter inside a brass circle, or oval, or within a solid border, or in places where no other quoin of wood or metal can be used.

Fig. 1 illustrates how this quoin is used in a mortised cut.



Fig. 1 illustrates the method of unlocking.

Price, per dozen, with key, net . . . . . \$2 00

# WROUGHT IRON CHASES.

These Chases are Unexcelled for Accuracy, Squareness and Strength. The Corners are Welded by Electricity.

**IMPORTANT.**—Other sizes made at approximate prices. In ordering, great care must be exercised to send the correct measurements, as all chases are made to order and cannot be taken back. In ordering, state (1) kind of chase required; (2) inside dimensions of each chase; (3) outside dimensions of each chase, or, in case of twin chases, the pair taken together; (4) if twin chases, give width of backs; (5) width of cross-bars (if any).

Nos. 1 to 3 are made of 1-inch iron, Nos. 4 to 6½ of 1½-inch iron, and Nos. 7 to 9 of 1¼-inch iron.

## NEWS CHASES.

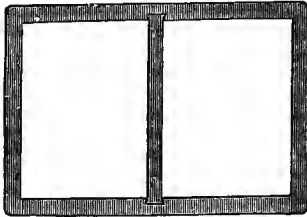

## PAIR TWIN CHASES.

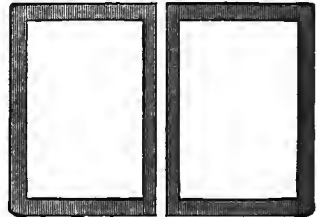

No.	Size, Over All.	Size Each, Inside.	Price, Each.
1	.17 × 20 <sup>7</sup> / <sub>8</sub>	15 × 18 <sup>7</sup> / <sub>8</sub>	\$5 50
2	.20 × 24 <sup>7</sup> / <sub>8</sub>	18 × 22 <sup>7</sup> / <sub>8</sub>	6 00
3	.24 × 28 <sup>7</sup> / <sub>8</sub>	22 × 26 <sup>7</sup> / <sub>8</sub>	6 75
4	.26 × 33 <sup>7</sup> / <sub>8</sub>	23 <sup>3</sup> / <sub>4</sub> × 31 <sup>5</sup> / <sub>8</sub>	7 50
4½	.27 × 39	24 <sup>3</sup> / <sub>4</sub> × 36 <sup>3</sup> / <sub>8</sub>	8 00
5	.29 × 41 <sup>7</sup> / <sub>8</sub>	26 <sup>3</sup> / <sub>4</sub> × 39 <sup>5</sup> / <sub>8</sub>	8 50
5½	.30 × 44	27 <sup>3</sup> / <sub>4</sub> × 41 <sup>3</sup> / <sub>8</sub>	9 00
6	.32 × 46 <sup>1</sup> / <sub>4</sub>	29 <sup>3</sup> / <sub>4</sub> × 44 <sup>1</sup> / <sub>2</sub>	9 50
6½	.33 <sup>1</sup> / <sub>2</sub> × 48 <sup>3</sup> / <sub>4</sub>	31 <sup>1</sup> / <sub>4</sub> × 46 <sup>1</sup> / <sub>2</sub>	10 00
7	.35 × 50 <sup>3</sup> / <sub>8</sub>	32 <sup>1</sup> / <sub>2</sub> × 48 <sup>3</sup> / <sub>8</sub>	10 50
8	.38 × 54 <sup>3</sup> / <sub>8</sub>	35 <sup>1</sup> / <sub>2</sub> × 52 <sup>3</sup> / <sub>8</sub>	11 50
9	.41 × 59 <sup>3</sup> / <sub>8</sub>	38 <sup>1</sup> / <sub>2</sub> × 57 <sup>3</sup> / <sub>8</sub>	12 50

No.	Size of Pair, Over All.	Size Each Half, Inside.	Price, per Pair.
1	.17 × 20 <sup>7</sup> / <sub>8</sub>	15 × 8 <sup>5</sup> / <sub>8</sub>	\$8 00
2	.20 × 24 <sup>7</sup> / <sub>8</sub>	18 × 10 <sup>5</sup> / <sub>8</sub>	9 25
3	.24 × 28 <sup>7</sup> / <sub>8</sub>	22 × 12 <sup>5</sup> / <sub>8</sub>	10 50
4	.26 × 33 <sup>7</sup> / <sub>8</sub>	23 <sup>3</sup> / <sub>4</sub> × 15	11 75
4½	.27 × 39	24 <sup>3</sup> / <sub>4</sub> × 17 <sup>5</sup> / <sub>8</sub>	12 50
5	.29 × 41 <sup>7</sup> / <sub>8</sub>	26 <sup>3</sup> / <sub>4</sub> × 19	13 25
5½	.30 × 44	27 <sup>3</sup> / <sub>4</sub> × 20 <sup>5</sup> / <sub>8</sub>	14 00
6	.32 × 46 <sup>1</sup> / <sub>4</sub>	29 <sup>3</sup> / <sub>4</sub> × 21 <sup>5</sup> / <sub>8</sub>	14 75
6½	.33 <sup>1</sup> / <sub>2</sub> × 48 <sup>3</sup> / <sub>4</sub>	31 <sup>1</sup> / <sub>4</sub> × 22 <sup>5</sup> / <sub>8</sub>	15 50
7	.35 × 50 <sup>3</sup> / <sub>8</sub>	32 <sup>1</sup> / <sub>4</sub> × 23 <sup>5</sup> / <sub>8</sub>	16 25
8	.38 × 54 <sup>3</sup> / <sub>8</sub>	35 <sup>1</sup> / <sub>4</sub> × 25 <sup>5</sup> / <sub>8</sub>	17 50
9	.41 × 59 <sup>3</sup> / <sub>8</sub>	38 <sup>1</sup> / <sub>4</sub> × 27 <sup>5</sup> / <sub>8</sub>	18 75

## \* NEWSPAPER CHASES, FOLIO.

Same Style as Twin Chases.

	Size of Pair, Over All.	Size Each Half, Inside.	Width of Backs.	Size of Iron.	Price, per Pair.
5-Column	.22 <sup>1</sup> / <sub>4</sub> × 29 <sup>3</sup> / <sub>8</sub>	12 <sup>3</sup> / <sub>4</sub> × 20	1 <sup>3</sup> / <sub>16</sub>	1 <sup>1</sup> / <sub>8</sub> × 5 <sup>5</sup> / <sub>8</sub>	\$10 00
6-Column	.24 × 33 <sup>7</sup> / <sub>8</sub>	15 × 21 <sup>3</sup> / <sub>4</sub>	1 <sup>3</sup> / <sub>16</sub>	1 <sup>1</sup> / <sub>8</sub> × 5 <sup>5</sup> / <sub>8</sub>	11 00
7-Column	.26 × 38 <sup>7</sup> / <sub>8</sub>	17 <sup>1</sup> / <sub>2</sub> × 23 <sup>3</sup> / <sub>4</sub>	1 <sup>3</sup> / <sub>16</sub>	1 <sup>1</sup> / <sub>8</sub> × 5 <sup>5</sup> / <sub>8</sub>	12 00
8-Column	.28 <sup>1</sup> / <sub>4</sub> × 43 <sup>5</sup> / <sub>8</sub>	19 <sup>3</sup> / <sub>4</sub> × 25 <sup>3</sup> / <sub>4</sub>	1 <sup>3</sup> / <sub>16</sub>	1 <sup>1</sup> / <sub>8</sub> × 5 <sup>5</sup> / <sub>8</sub>	13 25
9-Column	.30 <sup>1</sup> / <sub>4</sub> × 48 <sup>7</sup> / <sub>8</sub>	22 × 27 <sup>3</sup> / <sub>4</sub>	1 <sup>5</sup> / <sub>16</sub>	1 <sup>1</sup> / <sub>8</sub> × 5 <sup>5</sup> / <sub>8</sub>	14 50
Paper 24 × 36	.26 <sup>1</sup> / <sub>4</sub> × 39 <sup>7</sup> / <sub>8</sub>	18 × 24	1 <sup>3</sup> / <sub>16</sub>	1 <sup>1</sup> / <sub>8</sub> × 5 <sup>5</sup> / <sub>8</sub>	12 25

## \* NEWSPAPER CHASES, QUARTO.

Same Style as Twin Chases with Bars.

	Size of Pair, Over All.	Size Each Half, Inside.	Width of Backs.	Size of Iron.	Price, per Pair.
4-Column	.24 <sup>1</sup> / <sub>4</sub> × 35 <sup>7</sup> / <sub>8</sub>	16 × 22	1 <sup>3</sup> / <sub>16</sub>	1 <sup>1</sup> / <sub>8</sub> × 5 <sup>5</sup> / <sub>8</sub>	\$14 50
5-Column	.29 <sup>1</sup> / <sub>2</sub> × 44 <sup>1</sup> / <sub>8</sub>	20 × 27	1 <sup>3</sup> / <sub>16</sub>	1 <sup>1</sup> / <sub>8</sub> × 5 <sup>5</sup> / <sub>8</sub>	16 50
6-Column	.34 × 47 <sup>5</sup> / <sub>8</sub>	21 <sup>3</sup> / <sub>4</sub> × 31 <sup>1</sup> / <sub>2</sub>	1 <sup>3</sup> / <sub>16</sub>	1 <sup>1</sup> / <sub>8</sub> × 5 <sup>5</sup> / <sub>8</sub>	18 00
7-Column	.39 × 52 <sup>1</sup> / <sub>8</sub>	23 <sup>3</sup> / <sub>4</sub> × 36 <sup>1</sup> / <sub>4</sub>	1 <sup>5</sup> / <sub>16</sub>	1 <sup>3</sup> / <sub>8</sub> × 5 <sup>5</sup> / <sub>8</sub>	20 00
8-Column	.43 <sup>1</sup> / <sub>2</sub> × 56 <sup>1</sup> / <sub>8</sub>	25 <sup>3</sup> / <sub>4</sub> × 40 <sup>3</sup> / <sub>4</sub>	1 <sup>5</sup> / <sub>16</sub>	1 <sup>3</sup> / <sub>8</sub> × 5 <sup>5</sup> / <sub>8</sub>	22 00

\* These measures are for columns 13 ems Pica and 7-Point column rules, except for 9-column paper, when 8-Point column rules are used, allowing 1¼ inches for lock-up.

**PAIR TWIN CHASES, WITH BARS.**

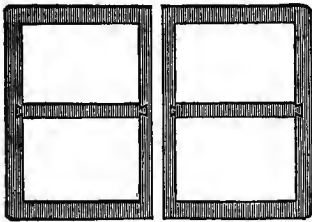

No.	Size of Pair, Over All.	Size Each Half, Inside.	Price, per Pair.
1 . . .	.17 × 20%	15 × 8%	\$11 25
2 . . .	.20 × 24%	18 × 10%	12 50
3 . . .	.24 × 28%	22 × 12%	13 75
4 . . .	.26 × 33%	23 3/4 × 15	15 00
4 1/2 . . .	.27 × 39	24 3/4 × 17%	15 75
5 . . .	.29 × 41%	26 3/4 × 19	16 50
5 1/2 . . .	.30 × 44	27 3/4 × 20%	17 25
6 . . .	.32 × 46%	29 3/4 × 21 1/2	18 00
6 1/2 . . . .	.33 1/2 × 48%	31 1/4 × 22%	18 75
7 . . . .	.35 × 50%	32 1/2 × 23%	20 00
8 . . . .	.38 × 54%	35 1/2 × 25%	21 25
9 . . . .	.41 × 59%	38 1/2 × 27%	22 50

**SKELETON CHASES.**



No.	Size, Over All.	Size Each, Inside.	Price, Each.
1 . . .	.17 × 20%	15 × 18%	\$4 50
2 . . .	.20 × 24%	18 × 22%	5 00
3 . . .	.24 × 28%	22 × 26%	5 75
4 . . . .	.26 × 33%	23 3/4 × 31%	6 50
4 1/2 . . . .	.27 × 39	24 3/4 × 36%	7 00
5 . . . .	.29 × 41%	26 3/4 × 39%	7 25
5 1/2 . . . .	.30 × 44	27 3/4 × 41%	7 75
6 . . . .	.32 × 46%	29 3/4 × 44%	8 00
6 1/2 . . . .	.33 1/2 × 48%	31 1/4 × 46%	8 50
7 . . . .	.35 × 50%	32 1/2 × 48%	9 00
8 . . . .	.38 × 54%	35 1/2 × 52%	10 00
9 . . . .	.41 × 59%	38 1/2 × 57%	11 00

**BOOK OR SHIFTING BAR CHASES.**

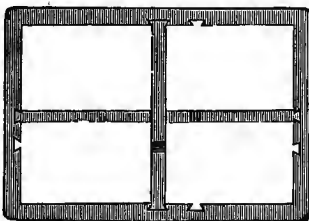

No.	Size, Over All.	Size Each, Inside.	Price, Each.
1 . . .	.17 × 20%	15 × 18%	\$7 50
2 . . .	.20 × 24%	18 × 22%	8 25
3 . . .	.24 × 28%	22 × 26%	9 00
4 . . .	.26 × 33%	23 3/4 × 31%	10 00
4 1/2 . . .	.27 × 39	24 3/4 × 36%	10 50
5 . . .	.29 × 41%	26 3/4 × 39%	11 00
5 1/2 . . .	.30 × 44	27 3/4 × 41%	11 50
6 . . .	.32 × 46%	29 3/4 × 44%	12 00
6 1/2 . . .	.33 1/2 × 48%	31 1/4 × 46%	12 50
7 . . .	.35 × 50%	32 1/2 × 48%	13 00
8 . . .	.38 × 54%	35 1/2 × 52%	14 00
9 . . .	.41 × 59%	38 1/2 × 57%	15 00

**QUADRUPLE CHASES.**

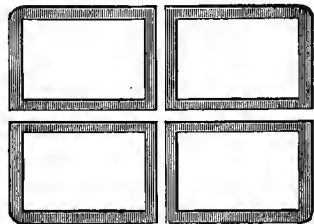

	Size Each Chase, Outside.	Size Each Chase, Inside.	Price per Set of Four
5-Col. . .	14 11/16 × 21 15/16	12 3/4 × 20	\$19 00
6-Col. . .	16 15/16 × 23 11/16	15 × 21 1/4	21 00
7-Col. . .	19 1/2 × 25 3/4	17 1/2 × 23 3/4	23 00

**HEADING CHASES, WITH CROSS BAR.**



8 × 17 in. inside (Flat Cap), each . . .	\$5 50
8 × 24 in. inside (Demi), each . . . . .	6 00
8 × 28 in. inside (Double Cap), each . . .	6 50

**WROUGHT IRON CHASES FOR JOB PRESSES.**

Made to Order Only.

Eighth Medium, each . . . . .	\$3 75
Quarter Medium, each . . . . .	4 50
Half Medium, each . . . . .	5 50
Half Super Royal, each . . . . .	7 25

**IRON SIDE AND FOOT STICKS.**

Straight, per inch . . . . .	\$0 04
Beveled, per inch . . . . .	0 05

Side and Foot Sticks are made, unless otherwise ordered, 1 1/2 inches shorter than inside measurement of the chase.

**ELECTROTYPE CHASES.**

Inside.	Rim.	Cast Iron.	Wrought Iron.
10 · 14	¼ × 1¾ .	\$1 75	\$3 50
12 · 18	¾ × 1¾ .	2 00	4 00

**CAST IRON CHASES.**

Size, Inside.	Price, Each.	Size, Inside.	Price, Each.	Size, Inside.	Price, Each.
4 × 5	\$0 42	6 × 30	\$1 12	10 × 31	\$1 40
4 × 24	1 05	8 × 21	1 05	12 × 14	1 12
5 × 7	0 60	8 × 32	1 20	12 × 17	1 20
5 × 16	0 82	8 × 40	1 95	12 × 20	1 30
5 × 28	1 12	9 × 12	1 05	12 × 24	1 35
6 × 43	1 87	9 × 18	1 20	12 × 30	1 40
6 × 8	0 60	9 × 25	1 35	14 × 22	1 35
6 × 12	0 82	10 × 14	1 12	14 × 26	1 40
6 × 20	1 05	10 × 18	1 20	16 × 28	1 75
6 × 24	1 05	10 × 22	1 27	18 × 24	1 80

**CHASES FOR C. & P. GORDON PRESSES.**

Size.	Cast Iron.	Cast Iron Screw.	Steel.	Steel Screw.
7 × 11 inches . . . . .	\$1 00	\$1 50	\$2 70	\$4 00
8 × 12 inches . . . . .	1 25	1 90	3 00	4 50
10 × 15 inches . . . . .	1 50	2 25	4 50	6 75
12 × 18 inches . . . . .	2 00	3 00	5 25	8 00
14 × 20 inches . . . . .	2 50	3 75	5 75	8 50
14½ × 22 inches . . . . .	3 00	4 50	6 00	9 00

**CHASES FOR GALLY UNIVERSAL PRESSES.**

	For 10 × 15 Press.	For 13 × 19 Press.	For 14 × 22 Press.
Cast iron . . . . .	\$2 00	\$2 25	\$2 75
Wrought iron . . . . .	5 50	6 50	7 25
* Steel skeleton . . . . .	5 50	6 50	7 25

\* Steel skeleton chases give more lock-up room, but do not add to printing capacity of press.

**CHASES FOR PEERLESS PRESSES.**

	For 8 × 12 Press.	For 9 × 13 Press.	For 10 × 15 Press.	For 11 × 17 Press.	For 14 × 20 Press.	For 14½ × 22 Press.
Cast iron . . . . .	\$1 50	\$1 50	\$2 00	\$2 00	\$2 75	\$3 00

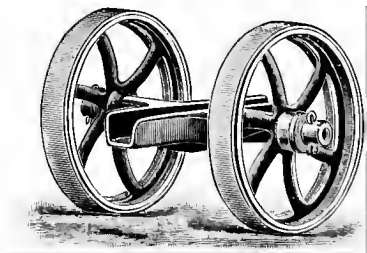

**FORM TRUCK.**

Both the Form Trucks listed below are of malleable iron. The Union Form Truck is painted red.

The use of a form truck should be insisted on in every press room of any size, not only because it is a time saver, but because sliding chases along the floor is a source of frequent accidents.

Iron tire . . . . .	\$3 00
Union Form Truck, with rubber tire . . . . .	5 00

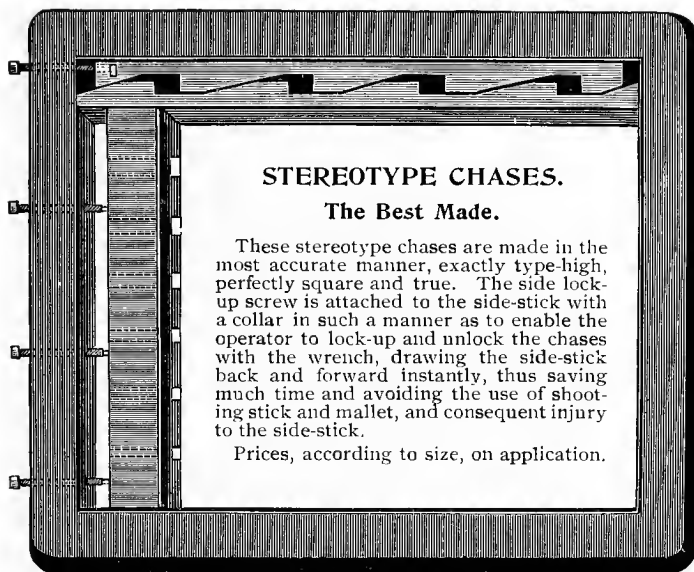

Lock-up Wrenches for Stereotype Chases .

. Price, \$2 50

### MAKE-UP TABLES.

These tables are used for making-up and carrying forms either to the beating table or matrix-rolling machine (or elevator, if the stereotype room is not on the same floor with the composing room), and are very substantially built of hard wood with patent double-roller revolving casters. The iron top is either smoothed off or covered with brass—the latter being preferred by the leading newspaper offices.

Size of Matter.	Price, Iron Top.	Price, Top Covered with Brass.
15×20 inches	\$40 00	\$50 00
18×24 inches	50 00	60 00
21×28 inches	55 00	65 00
24×32 inches	65 00	75 00



### IRON-TOP BEATING TABLES.

For Paper Process.

Size of Matter.	Price, Fixed Top.	Price, Elevating Top.	Size of Matter.	Price, Fixed Top.	Price, Elevating Top.
15×20 inches	\$40 00	\$75 00	21×28 inches	\$55 00	\$105 00
18×24 inches	50 00	95 00	24×32 inches	65 00	125 00

IMPOSING TABLES AND MARBLE STONES.

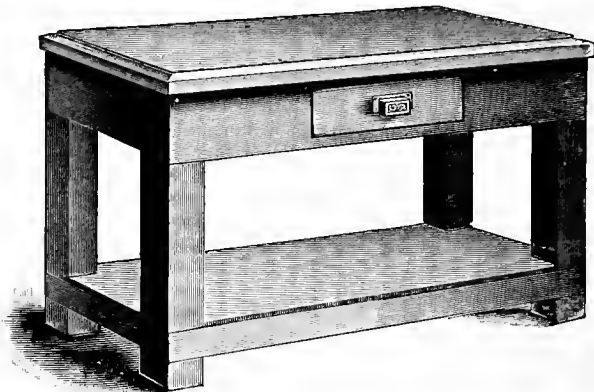

Square-leg Imposing Table.

Square-leg imposing tables are made of hard wood, varnished and bolted together. Round-leg imposing tables are made of hard wood, cherry finish, and are bolted together. Tables over six feet in length have six legs (see illustration below). The larger tables have two drawers, one at each end, and the smaller one drawer, which pulls out both sides. A "coffin" is a hard wood frame which serves as a bed for the stone, protects its edges, and affords a rest for galleys when used for sliding off matter.

	Imposing Stone only.	Imposing Stone in Coffin.	Round- leg Table and Stone.	Square- leg Table and Stone.
For 6-Column paper, 2 pages 24×36 in.	\$ 6 00	\$ 7 75	\$18 75	\$15 00
For 7-Column paper, 2 pages 26×44 in.	8 00	10 00	22 00	18 00
For 8-Column paper, 2 pages 28×50 in.	10 00	12 50	26 50	21 50
For 9-Column paper, 2 pages 32×60 in.	12 50	15 50	30 00	25 50
For 7-Column paper, 4 pages 26×76 in.	13 75	17 25	32 25	27 00
For 8-Column paper, 4 pages 28×80 in.	15 50	19 50	37 00	32 00
For 9-Column paper, 4 pages 30×90 in.	18 75	23 50	43 50	38 00
For 6-Column quarto, 4 pages 36×60 in.	15 00	18 50	37 00	32 00
For 7-Column quarto, 4 pages 48×60 in.	20 00	25 00	45 50	40 00

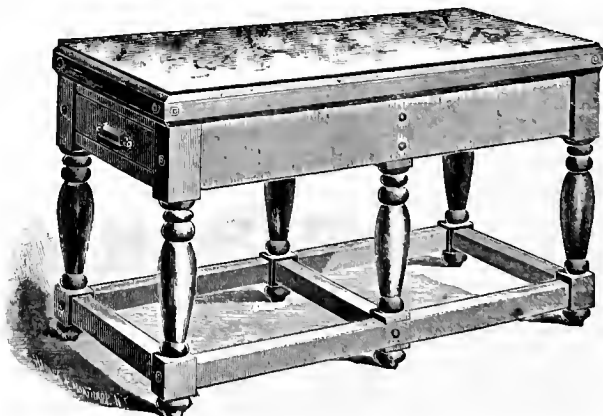

Round-leg Imposing Table.



IMPOSING TABLES WITH LETTER BOARDS.

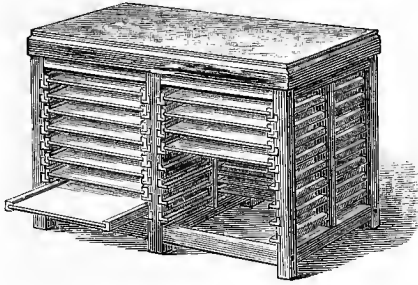

No. 9. With 36×60-inch Marble Top; has thirty-two Letter Boards, each 17½×26 inches inside.

No better disposition of the space underneath an imposing table can be made than to use it for letter boards. If the type is dead, it is shifted from the stone to the board without loss of time; if the matter is alive, it is handy for imposition.

These tables are made in the most substantial manner, of hard wood, varnished, and strongly and firmly bolted together. The boards are made of hard wood, closed at sides and back, and are rabbeted in front to receive galley when sliding off type.

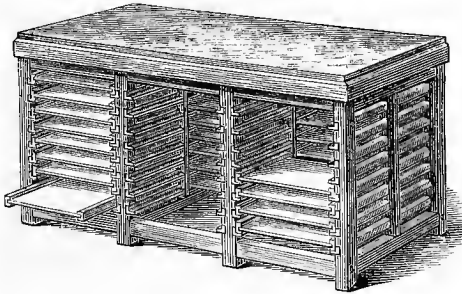

No. 10. With 40×80-inch Marble Top; has 48 Letter Boards, each 19½×22½ inches inside.

Prices with Hard Marble Stones.

	Number of Boards.	Size of Stone.	Size of Boards.	Without Boards.	Boards each.	Complete with Boards.
No. 2 . . .	10 .	24×36 .	22 × 32 .			\$40 00
No. 3 . . .	10 .	32×48 .	30 × 44 .			60 00
No. 9 . . .	32 .	36×60 .	17½×26 .	\$42 50 .	\$1 00 . . .	72 50
No. 10 . . .	48 . .	40×80 .	19½×22½	55 00 .	0 90 . . .	95 50

IRON IMPOSING SURFACES

Supplied any size to order

2½ cents per square inch.

MARBLE INK SLABS.

8×12 inches . . . . .	\$1 25	18×24 inches . . . . .	\$3 75
12×18 inches . . . . .			\$2 00

**WOOD FURNITURE, REGLET AND SIDE-STICKS.**

	Per yard.		Per yard.
Pearl to Pica Reglet . . . . .	\$0 02	6 to 9-line Furniture . . . . .	\$0 06
Gr. Primer Reglet to 2-line Furniture . . . . .	0 03	10 to 12-line Furniture . . . . .	0 08
3 to 5-line Furniture . . . . .	0 04	13 to 16-line Furniture . . . . .	0 10

**SIDE-STICKS**, thin, medium or thick . . . . . Per yard, \$0 06

**WOODEN QUOINS.**

	Boxes of	Burlap Bags	Burlap Bags
	100.	of 500.	of 1000.
Hickory . . . . .	\$0 40	\$1 80	\$3 50
Boxwood . . . . .	0 60	2 70	5 25
Hickory, in barrels, containing about 7000, per 1000 . . . . .			3 25
Boxwood, in barrels, containing about 7000, per 1000 . . . . .			5 00

**LABOR-SAVING REGLET CASES.**

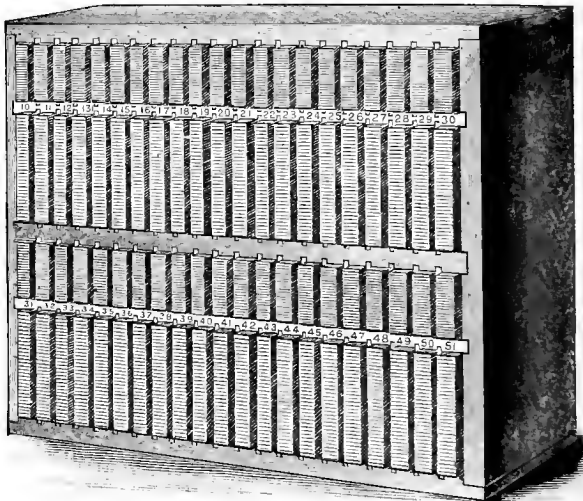

Reglet Case No. 4. 2100 pieces, \$8 00.

Nos. 3, 4, 5, 6 are made same style as above illustration. The reglet lies flat, and varies by ems up to 51 ems, and by 5 ems in longer lengths. Nos. 1 and 2 are square boxes, in which reglet is put in on end, and varies by 10 ems up to 60 ems, with 72 and 120 ems added in the No. 2 case. One-half the pieces in each case are Pica body; the other half, Nonpareil body.

Case.	No. of Pieces.	No. of Yards.	Lengths in Case.	Price.
No. 1 . . . . .	1800	300	10 to 60 ems.	\$ 8 00
No. 2 . . . . .	2400	600	10 to 120 ems.	14 00
No. 3 . . . . .	4200	550	10 to 51 ems.	15 00
No. 4 . . . . .	2100	275	10 to 51 ems.	8 00
No. 5 . . . . .	6300	1500	10 to 150 ems.	38 00
No. 6 . . . . .	3150	750	10 to 150 ems.	20 00

**LABOR-SAVING FURNITURE, WITHOUT CASES.**

Half Font of 280 pieces, in a box . . . . .	\$2 75
Single Font of 560 pieces, in a box . . . . .	5 00
Double Font of 1120 pieces, in a box . . . . .	10 00

LABOR-SAVING FURNITURE.

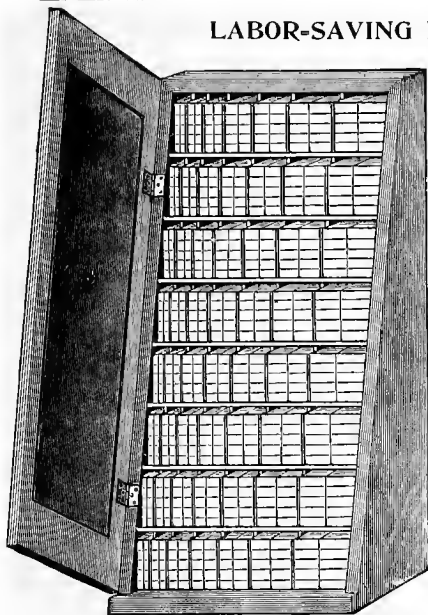

No. 3. Single Case, with Partitions and Door.

This Labor-Saving Furniture is thoroughly oiled, and cut to the Point standard. Every piece has the size stamped on the end.

Cases are made *with* or *without* partitions. The usefulness of the font is doubled by having it in a case with partitions.

A single case contains 560 pieces, divided into 10 pieces, each 10, 15, 20, 25, 30, 40, 50 and 60 ems long by 2, 3, 4, 5, 6, 8 and 10 ems wide.

A Half Case contains half the number of pieces held in a Single Case.

THE No. 7 MAMMOTH CASE

Is especially designed for large offices, and contains the following assortment of selected furniture, from 10 to 160 ems long: 270 pieces each 2-line, 3-line and 4-line furniture; 225 pieces each 5-line and 6-line furniture; 135 pieces each 8-line and 10-line furniture—assorted in 10, 15, 20, 25, 30, 40, 50, 60, 70, 80, 90, 100, 120, 140 and 160 ems lengths. There is a larger proportion of the narrower and most-used sizes than of the wide furniture.

- No. 1. Half Case contains 280 pieces, with partitions . . . \$ 6 00
- No. 2. Half Case contains 280 pieces, without partitions . . . 5 00
- No. 3. Single Case contains 560 pieces, with partitions . . . 10 00
- No. 4. Single Case contains 560 pieces, without partitions . . . 8 00
- No. 5. Double Case contains 1120 pieces, with partitions . . 18 00
- No. 6. Double Case contains 1120 pieces, without partitions . 15 00
- No. 7. Mammoth Case, designed for large offices, with partitions, no door (see description above) . . . . . 40 00

No. 7. Mammoth Case, designed for large offices, with partitions, no door (see description above)

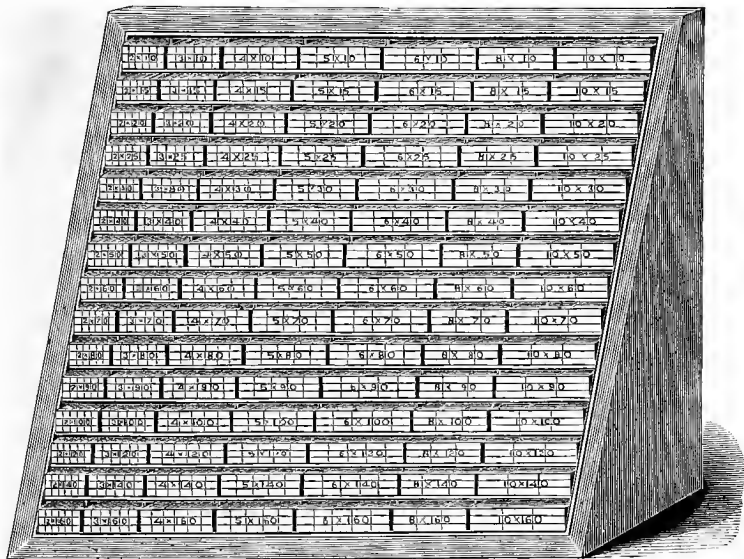

No. 7. Mammoth Labor-Saving Furniture Case.

LABOR-SAVING LEAD RACKS.

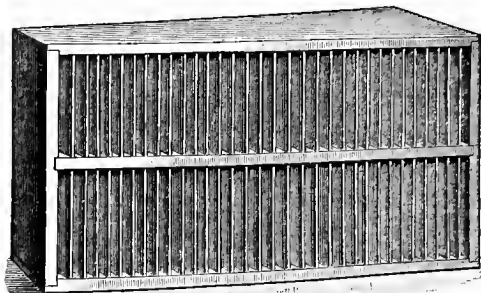

Two-tier Wisconsin Lead Rack; 4 to 12½ by ens, 13 to 60 by ems.

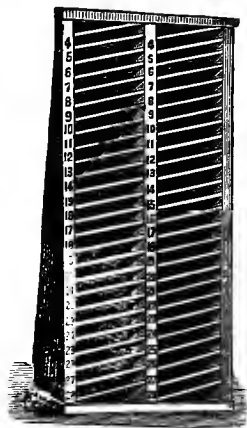

Eureka Lead Rack.

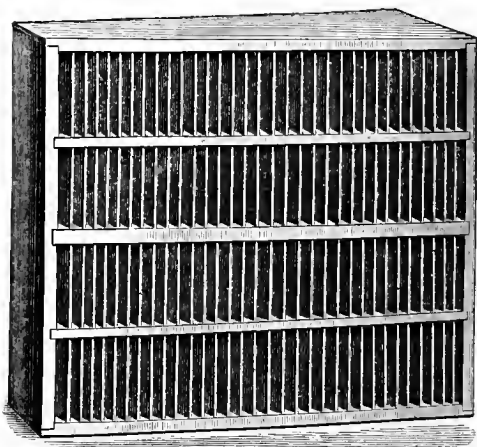

Four-tier Wisconsin Lead Rack; 4 to 12½ by ens, 13 to 60 by ems twice.



Boston Lead Rack.

Two-tier Wisconsin Lead Rack (see illustration above) . . . . . \$6 00

Takes leads from 4 to 12½ ems (varying by ens), and from 13 to 60 ems (varying by ems), the length being stamped over each compartment. Compartments are eight inches high. Will hold 750 pounds of leads and slugs.

Four-tier Wisconsin Lead Rack (see illustration above) . . . . . 9 00

Has two compartments each for all sizes in the two-tier rack, and is similar in design and construction. Will hold 1500 pounds of leads and slugs.

Eureka Lead Rack (see illustration) . . . . . 2 50

Boston Lead Rack, set of four (see illustration) . . . . . 5 40

- No. 1 Boston Lead Rack holds 4 to 15 ems lengths . . . . . \$0 90
- No. 2 Boston Lead Rack holds 16 to 30 ems lengths . . . . . 1 20
- No. 3 Boston Lead Rack holds 31 to 45 ems lengths . . . . . 1 50
- No. 4 Boston Lead Rack holds 46 to 60 ems lengths . . . . . 1 80

**HANDY LETTER BOARD CABINETS.**

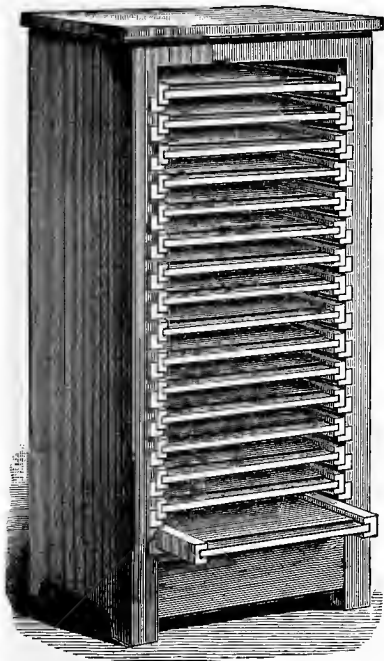

Handy Letter Board Cabinet with Sixteen Boards.

For the storage and safe keeping of job work these cabinets are unrivaled. Their cost will be saved in a few months by the prevention of pi. They occupy a floor space of 16×19 inches, with letter boards of 12×15 inches inside, and are made of hard wood throughout, in a solid and substantial manner. Boards are closed at sides and back, and are rabbeted in front to receive galleys. They are well-named "Handy." For job work within their size—and this the larger variety of such work—these small boards are much superior to the larger boards usually put under imposing tables, as it is a back-breaking job to get a form from these large boards when they are full of type.

It is distinctly an economy to place dead and live forms in such a receptacle as this, rather than to incumber useful space on an imposing stone, the type on which is always liable to damage. The protection they afford from dust is also worthy of consideration.

With 10 boards	\$10 50
With 12 boards	12 00
With 16 boards	15 00

Other sizes made to order at proportionate prices.

**HARD-WOOD LETTER BOARDS, TO FIT CASE STANDS.**

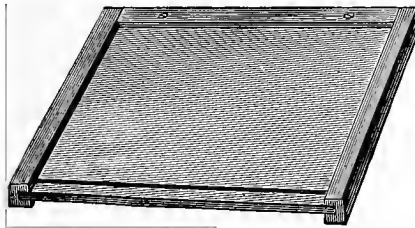

Made of selected stock, smooth and true, with closed sides and backs, rabbeted in front to allow matter to slide on galleys easily.

No. 1 fits two-third case stands; No. 2, three-quarter stands, and No. 3, full-size stands or racks.

No. 1, 21¼×20½ inches outside . . . . .	\$1 20
No. 2, 26¼×20½ inches outside . . . . .	1 40
No. 3, 32¼×20½ inches outside . . . . .	1 70

*For Imposing Tables with Letter Boards, see page 539.*

# PRICE LIST OF CASES.

For illustrations of Cases, see pages 548 and 549.

## PATENT NEW DEPARTURE TYPE CASES.

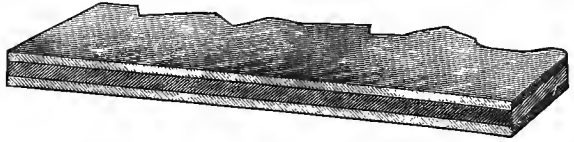

Shows three-ply case bottom, which will not warp nor crack.

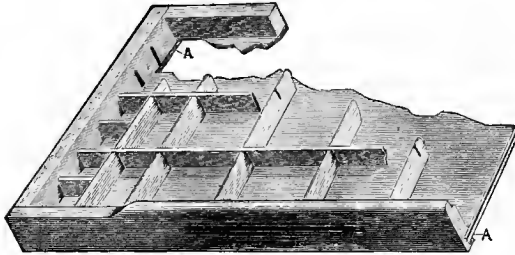

Shows at AA how the three-ply bottoms are set into the front and side rails, so that the case slides on the rails instead of on the case bottoms.

Our cases all have patent "New Departure" three-ply bottoms, which prevent splitting, warping and shrinking. These bottoms are set into the side and front rails (see AA), so that the case slides on the side rails. As the grain of the side rails and of the case-runs in stands and cabinets run the same way, the cases slide much easier and with considerable less wear and tear.

## FULL-SIZE CASES.

Size, 32 $\frac{1}{4}$  x 16 inches.

	Clasp Cases.	Ordinary Cases.
News Cases, per pair	\$1 75	\$1 60
Cap Case	0 88	0 80
German News Cases, per pair		1 60
Italic or Job Case	1 00	0 90
California Job Case (see cut page 548)	1 00	0 90
Yankee Job Case (see cut page 549)		1 00
Improved Job Case (see cut page 548)		1 20
Paterson Job Case (see cut page 548)		1 00
New York Job Case (see cut page 548)		1 00
Triple Case	1 00	0 90
Double Lower Case (see cut page 548)		1 20
Rule Case		1 15
Space and Quad Case (see cut page 549)		1 00
Lead and Slug Case		1 00
Border Case		1 25
Figure Case		1 00
Metal Furniture Case (double depth), takes three layers of Furniture (see cut page 549)		2 00
Metal Furniture Case (single depth), takes two layers of Furniture (see cut page 549)		1 50
Blank Case		0 65
Wood Type No. 1 or Script Case, with bars (see page 549)		0 90

See also *Special Wood-Type Cases* listed on next page.

## THREE-QUARTER CASES.

Size, 26 $\frac{1}{4}$  x 16 inches.

	\$1 60	\$1 50
News Cases, per pair		0 75
Cap Case	0 85	0 80
Italic or Job Case	0 90	0 80
California Job Case (see cut page 548)	0 90	0 80
Yankee Job Case (see cut page 549)		0 85
Triple Case		0 80
Blank Case		0 60

**TWO-THIRD CASES.**

**CAUTION.**—There are two widths of two-third cases in use. If cases are required to fit stands already in use it is necessary, when ordering, to state exact width required, otherwise we will send our standard width.

	Ordinary Cases.
New Cases, per pair . . . . .	\$1 40
Job Case (thirty-two cap boxes) . . . . .	0 75
Yankee Job Case (twenty-eight cap boxes)	0 75
Lead and Slug Case . . . . .	0 75
Brass Leader Case . . . . .	0 75
Script Case . . . . .	0 75
Improved Job Case (19¾ inches deep). Is deeper than the regular case, and has additional boxes for small caps . . . . .	0 90
Border Case . . . . .	0 90
Blank Case . . . . .	0 45

**ROOKER CASES.**

A popular size for newspaper offices. Furnished to order only. Size, 28½ × 14 inches.

	Patent Clasps.
News Cases, per pair . . . . .	\$1 75
Italic or Job Case . . . . .	1 00

**SPECIAL CASES.**

	Ordinary Cases.
Wood-Type Case No. 1 (16 × 32¼ inches) . . . . .	\$0 90
Wood-Type Case No. 2 (23 × 32¼ inches) . . . . .	1 00
Mammoth Wood-Type Case No. 3 (23 × 44 inches) . . . . .	1 30
Wisconsin Combination "Quarter" Cases, Nos. A, B, C, D, for holding piece fractions, signs, fractions, figures and borders (see cut page 546), each . . . . .	0 65

**RULE CASES.**

Regular Rule Case, full-size . . . . .	\$1 15
Regular Rule Case, two-third size (see note at top of page) . . . . .	0 90
Compact Rule Case. Four of them fit in a full-size blank case (see page 547), each . . . . .	0 90
* Harris Rule Case, No. 1, holds two 8-pound fonts . . . . .	1 25
* Harris Rule Case, No. 2, holds one 16-pound font . . . . .	1 00
* Harris Rule Case, No. 3, } used together, hold one 32-pound font	1 00
* Harris Rule Case, No. 4, }	1 00
Full-size Blank Case, to hold four Harris Rule Cases . . . . .	0 65

\* See cut and description, page 547.

**PATENT CLASP CASES.**

These cases are of unusual strength, owing to the use of a brass clasp over the corner of each box and a long pin which is driven through center of each clasp and clinched, holding the partitions firmly to the bottom of the case. This feature, in combination with our "New Departure" case bottoms, makes these cases the strongest and most durable, especially for body type and in newspaper offices.



Section of Patent Clasp Case.

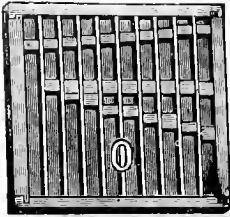

**INDIVIDUAL LEAD OR RULE CASE.**

In this a compositor may keep his much valued 12-to-Pica and other thicknesses of leads for justifying purposes, his pickups of dashes, rule, etc. The case can be kept in his drawer or on his galley rest. It has boxes from 1 to 9½ ems (varying by ems), from 10 to 22 ems (varying by ems), and from 22 to 28 ems (varying by two ems), with a long box for longer lengths. It is also useful for holding a small font of labor-saving brass rule.

Each, 7×7½ inches over all . . . . . \$o 75  
 Four of them fit inside a Full-sized Blank Case.

**LEADER BOX.**

The handiest receptacle for leaders. Can be put on a cap case, on a stone, or on a galley rest, bringing leaders close to hand. One or more required in every office for every size of body type used.

Each, 5×8×1¼ inches over all . . . \$o 25  
 Per dozen . . . . . 2 50

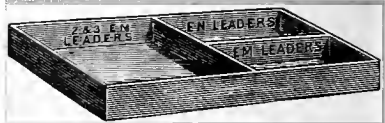

**WISCONSIN COMBINATION "QUARTER" CASES.**

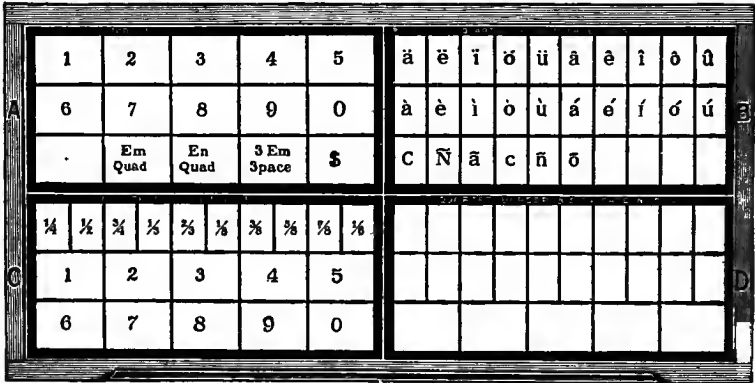

Shows four "Quarter" Cases in Full-size Blank Case.

Signs, Borders, Accents, Split Fractions, although most expensive, are usually stowed away in odd boxes of cap cases, and are rarely to be found when needed. "Quarter" Cases supply a means of keeping these valuable sorts where they can be found. They can be placed on a cap case, on a stand, or on the stone, convenient to hand of compositor. In setting mathematical work, foreign languages, dictionaries, and special catalogues, these "Quarter" Cases will prove invaluable. We show a few schemes for laying signs, fractions, etc., but various other uses for special purposes will suggest themselves to the "intelligent compositor."

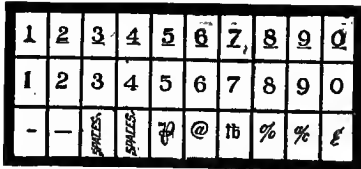

For Split Fractions and Commercial Signs.

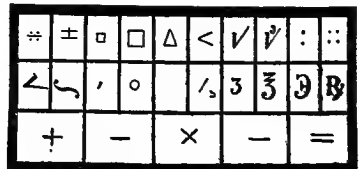

For Algebraic and Medical Signs.

Quarter Case No. A, for Figures, etc. . . . . \$o 65  
 Quarter Case No. B, for Accents, Split Fractions, etc. . . . . o 65  
 Quarter Case No. C, for Figures, Fractions, etc. . . . . o 65  
 Quarter Case No. D, for Signs, Borders, etc. . . . . o 65  
 Per set of four, in regular Full-size Blank Case . . . . . 3 25



**HARRIS RULE CASES.**

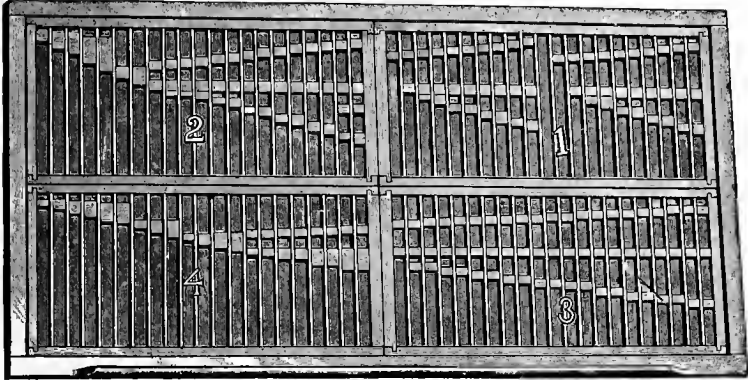

Four Harris Rule Cases in a Full-size Blank Case. Price, \$4 90.

In HARRIS RULE CASES the rule cannot fall flat—must always stay on end. Pi is prevented, because each box is accurately adjusted for its special size—for instance, a 21-em rule will not go into the 20-em rule box. Generous provision is made for the smaller sizes—the most valuable sizes in a labor-saving font. The cases may be used in sets or separately, as Nos. 1 and 2 are complete in themselves. Four of them fit into a full-size blank case.

The rule referred to below is 2-Point, which is the most used.

No. 1 Harris Rule Case holds two complete small fonts of Labor Saving Rule, each weighing 8 pounds, or 16 pounds in all. Each half of this case holds eighteen pieces each length from 1 to 8½ ems (varying by ems), and eighteen pieces each from 9 to 18 ems (varying by ems) and nine pieces each 19, 20, 21, 22, 24, 26 and 28 ems, besides boxes for right and left miters.

No. 2 Harris Rule Case holds one complete font of 16 pounds weight or less. It has compartments for thirty-six pieces each from 1 to 9 ems long (varying by ems), eighteen pieces each from 10 to 24 ems long (varying by ems), and eighteen pieces each of 26, 28, 30, 32, 34, 36 ems long, besides boxes for right and left miters. A large proportion of small lengths allowed for.

Nos. 3 and 4 Harris Rule Cases are designed to be used together to hold a font of rule suitable for a large office, weighing 32 pounds or less. Two and in some cases four boxes are used to hold the most-used sizes. Each case has its proportion of the small sizes, so that if it is desired to carry one case to a compositor's stand for use in rule work, the other is available in its regular place with a good working font. These cases have compartments for seventy-two pieces each from 1 to 9 ems long (varying by ems), thirty-six pieces each from 10 to 24 ems long (varying by ems), and eighteen pieces each from 25 to 36 ems long (varying by ems), and boxes for right and left miters.

Harris Rule Case No. 1, holds two 8-pound fonts	\$1 25
Harris Rule Case No. 2, holds one 16-pound font	1 00
Harris Rule Case No. 3, } used together, hold one 32-pound font {	1 00
Harris Rule Case No. 4, }	1 00
Full-size Blank Case, to hold four of above	0 65

**COMPACT RULE CASE.**

Has compartments for brass rule from 1 to 36 ems Pica, and from 1½ to 9½ ems Pica, with places for miters. Size outside, 7¾ × 15¼ inches. Four fit in a full-size blank case. For Full-size Rule Cases see page 545.

Price . . . . . \$0 90

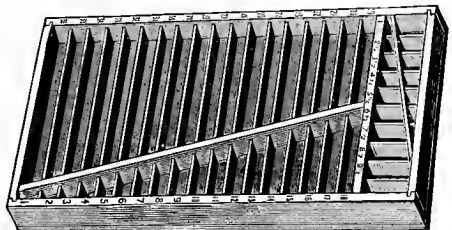

ILLUSTRATIONS OF CASES.

It is unnecessary to illustrate the most-used styles of cases. Nearly all the cases illustrated here have exceptional merit.

**CALIFORNIA JOB CASE.**

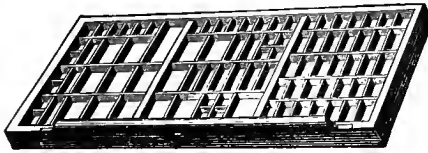

Has fourteen boxes less on cap side than the regular Italic Job Case, thus giving more space for the cap alphabet. A more satisfactory case for the ordinary job font than the Italic Job Case, especially in three-quarter size.

Full-size . . . \$0 90  
Three-quarter . . . 0 80

**IMPROVED JOB CASE.**

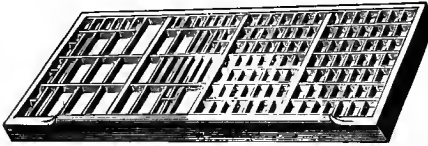

Holds caps, small caps, lower case and figures, or a cap and lower-case font (with figures) and an extra cap font. Will also hold three cap fonts, all with figures. Made full-size only.

Price . . . \$1 20

**NEW YORK JOB CASE.**

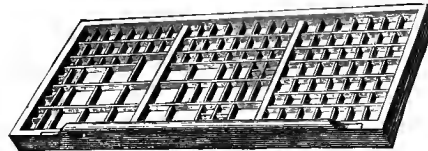

Holds caps, small caps, lower case and figures. The small caps are placed on the same side as the lower-case boxes, and above them. The lower-case boxes are therefore smaller than in a California Job Case. Made full-size only.

Price . . . \$1 00

**PATERSON JOB CASE.**

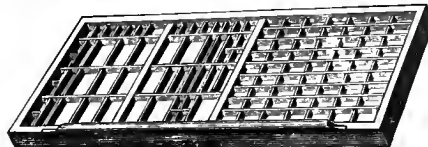

Holds caps, small caps, lower case and figures. The small caps are placed above the cap boxes, all of which are widened, thereby reducing the sizes of the lower-case boxes. A very useful case. Made full-size only.

Price . . . \$1 00

**DOUBLE LOWER CASE.**

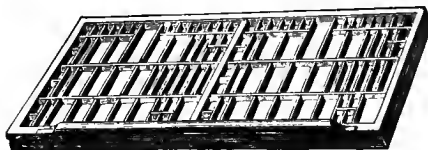

A most useful case. In most job fonts the caps occupy as much space as the lower case, while ordinary job cases give the caps one-half the room allotted the lower-case. In this case the space is divided equally between the caps and lower case. Made full-size only.

Price . . . \$1 20

**ROOKER CAP CASE.**

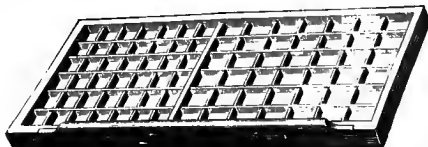

Made only in Rooker size (28 $\frac{1}{4}$  x 14 $\frac{1}{4}$ ). Gives more space for caps and less for small caps than the regular cap case. Rooker cases are two inches narrower than ordinary cases, and cannot be used on the same stands.

Price . . . \$0 88

ILLUSTRATIONS OF CASES.

YANKEE JOB CASE.

In two-third size this case is a necessity, but in full- and three-quarter sizes it is inferior in utility to other job cases.

Full-size . . . . .	\$1 00
Three-quarter . . . . .	0 85
Two-thirds . . . . .	0 75

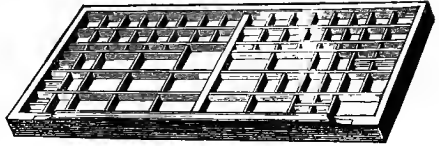

SPACE AND QUAD CASE.

This is an absolutely essential case in offices where economy of time and material is a consideration. Each case holds eight sizes of spaces and quads. Made full-size only.

Price . . . . .	\$1 00
-----------------	--------

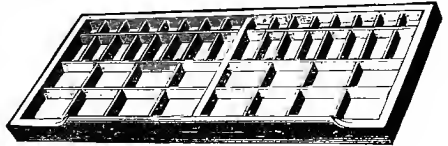

METAL FURNITURE CASE.

A handy receptacle for metal furniture. There are compartments for 1, 2, 3, 4, 5, 6, 8, 10, 15, 20, 25 and 50 ems. The double-depth case takes three layers of furniture; the single-depth case takes two layers. The latter can be put in a full-size case stand or rack, and the double-depth case is for use on top of a stand or cabinet, or a special place can be made for it under the stone. Made full-size only.

Double-depth . . . . .	\$2 00
Single-depth . . . . .	1 50

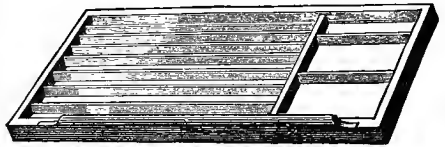

SCRIPT OR WOOD-TYPE CASE.

Although mostly sold for wood type, these cases are made so accurately as to be suitable for large Script founts. The movable partitions are adjustable by Picas. Nothing injures expensive Script type so much as tumbling about in a case. The use of Script cases will save type. Made in full- and two-third sizes.

Full-size . . . . .	\$0 90
Two-third size . . . . .	0 75

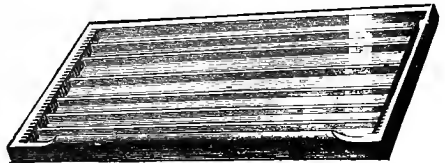

MAMMOTH WOOD-TYPE CASE.

No. 3 (Mammoth) Wood-Type Case, 23x44 inches, with slotted sides. For special rack to hold this size case, see page 51. There are two more sizes of Wood-Type Cases made. For prices see page 545.

Price of No. 3 Wood-Type Case . . . . .	\$1 30
---	--------

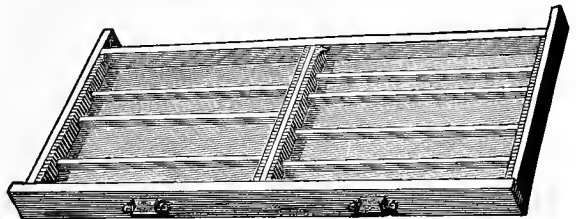

CASE STANDS.



No. 6. Double News Stand, with Eight Racks.

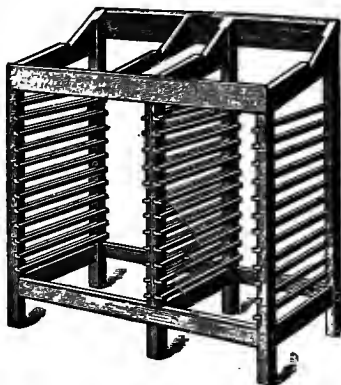

No. 11. Double Job Stand, with Racks for Twelve Full-size and Twelve Two-third Cases.

PRICE LIST OF CASE STANDS.

No. 1.	Single, without racks . . . . .	\$2 75
No. 2. <sup>⊗</sup>	Single, with racks for 12 two-third cases . . . . .	3 00
No. 2½	Single, with racks for 12 three-quarter cases . . . . .	3 00
No. 4.	Single, with racks for 12 full-size cases . . . . .	3 25
No. 6.	Double News, with racks for 8 full-size cases (see illustration) . . . . .	3 75
No. 8.	Double News, with racks for 12 full-size cases . . . . .	4 75
No. 11.*	Double Job Stand, with racks for 12 full-size and 12 two-third cases (see illustration) . . . . .	5 50
No. 12.	Double Job Stand, with racks for 12 full-size and 12 three-quarter cases . . . . .	5 75
No. 15.	Double Stand, with Galley Rest and racks for 24 full-size cases (see illustration) . . . . .	6 00
No. 17.	Double City Stand, with racks for 30 full-size cases (see illustration) . . . . .	9 50

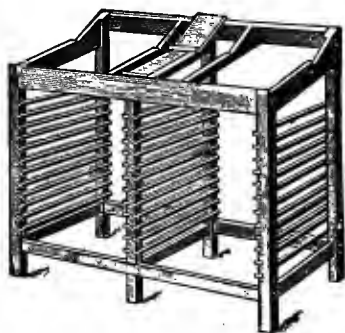

No. 15. Double Stand, with Galley Rest, and Racks for Twenty-four Full-size Cases.

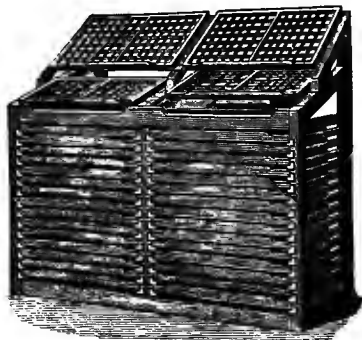

No. 17. Double City Stand. The upper cases project over the lower, bringing the caps nearer the hand. There is a shelf to hold a galley under the lower case, which can be pushed back to permit matter to be emptied on the galley.

\* CAUTION.—There are two widths of two-third cases in use. In ordering it is necessary to state exact width of two-third case the stand is required to hold, otherwise we will send stands to take in our standard width of two-third case.

NEW YORK SPACE-SAVING CASE STANDS.

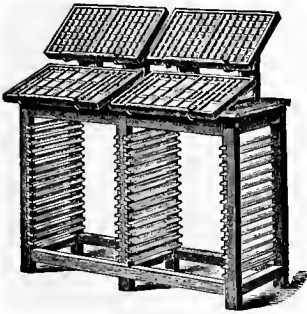

New York Double Stand.

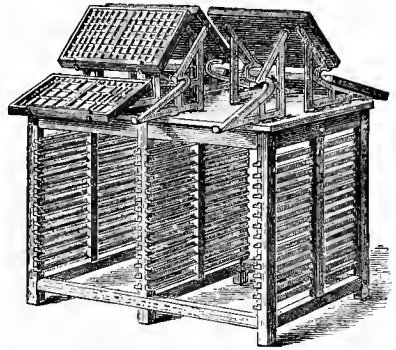

New York Quadruple Stand (see end view below).

These are *space-saving, rent-reducing stands*. Two New York Double Stands, holding sixty cases in racks and four pairs cases on top, occupy eighteen square feet of floor space, as against thirty square feet occupied by two ordinary double stands, holding at most forty-eight cases in racks and four pairs cases on top—a saving of twelve square feet. Two Double City Stands occupy a floor space of twenty-five square feet as against seventeen feet occupied by one Quadruple New York Stand—a saving of eight square feet. This saving is obtained by making the racks correspond to size of cases exactly, bringing forward the cap cases so that they do not overhang at the back of stand (as they do on ordinary stands), and extending the lower cases several inches into the alley.

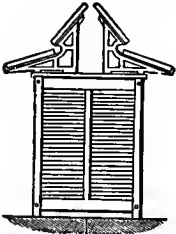

End view of New York Window and Quadruple Stands.

OTHER POINTS OF SUPERIORITY.

The lower cases project into the alley several inches, affording the compositor ample leg room, and allowing him to get closer to the type. The angle of the lower case is just right for rapid setting. The upper case is raised above the lower, and brought forward closer to the compositor's hand, while not obstructing the figure boxes of the lower case. The cases are held on strong iron brackets, securely screwed to a hard-wood top, which is perfectly smooth, and very useful for storing tied-up matter or for other purposes.

The Window Stand is a rearrangement of the Double Stand, so that it occupies a square area, and is very suitable for placing opposite a window.

New York Single Stand, with racks for fifteen cases . . .	\$ 6 50
New York Double Stand, with racks for thirty cases . . .	10 50
New York Quadruple Stand, with racks for sixty cases . . .	18 00
New York Window Stand, with racks for thirty cases . . .	10 50

CASE RACKS.

Made of hard wood, bolted together, and the higher racks are braced at the center with iron rods to prevent spreading.

Full-size Cases.	Height.	
Single, to hold 10 cases . . .	38 inches . . .	\$ 5 50
Single, to hold 16 cases . . .	50 inches . . .	7 00
Single, to hold 20 cases . . .	60 inches . . .	8 00
Single, to hold 24 cases . . .	70 inches . . .	9 00
Single, to hold 30 cases . . .	84 inches . . .	10 00
Double, to hold 40 cases . . .	60 inches . . .	14 00
Double, to hold 60 cases . . .	84 inches . . .	18 00

Made to hold two-third and three-quarter cases at same prices. In ordering for two-third cases it is necessary to state exact width of cases, as there are two widths of two-third cases in use.

WOOD-TYPE CASE RACK.

Single, to hold 20 No. 3 Wood-Type Cases . . .	\$9 00
A No. 3 Wood-Type Case is 23 x 44 inches over all.	

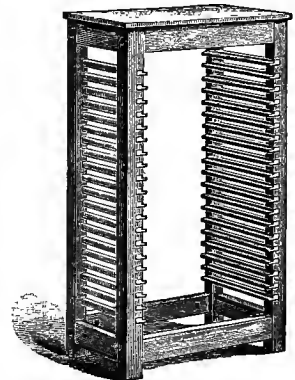

Case Rack for Twenty Full-size Cases.

WROUGHT IRON CASE STANDS.

Made of Tubular Iron, with Strengthened and Bolted Joints. The Best Made of this Class of Stand.

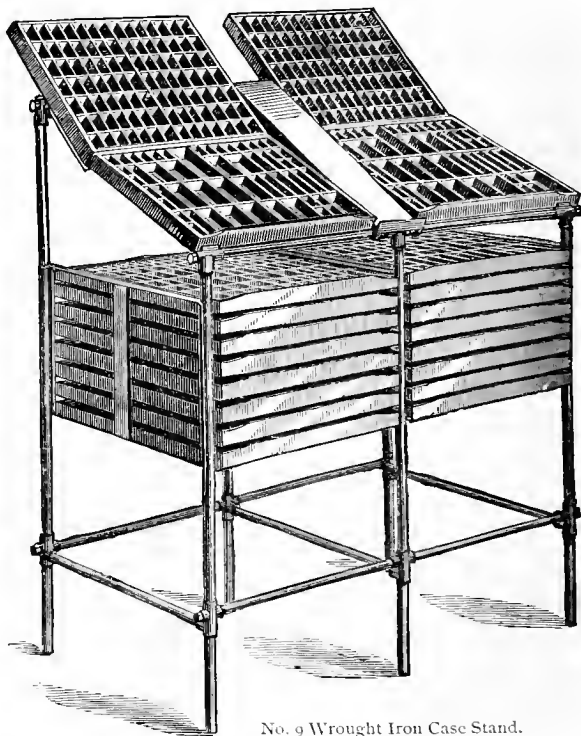

No. 9 Wrought Iron Case Stand.

No. 2.	Single, with racks for 8 full-size cases . . . . .	\$10 50
No. 3.	Single, with racks for 8 full-size cases and galley rest . . . . .	11 50
No. 5.	Double, with racks for 8 full-size cases . . . . .	13 50
No. 6.	Double, with racks for 8 full-size cases and galley rest . . . . .	15 00
No. 7.	Double, with racks for 8 full-size cases, galley rest, and 16 galley racks . . . . .	23 50
No. 8.	Double, with racks for 8 full-size and 8 two-third cases . . . . .	17 00
No. 9.	Double, with racks for 16 full-size cases and galley rest (see cut) . . . . .	18 50
No. 10.	Double, with racks for 8 full-size and 8 two-third cases, galley rest, and 16 galley racks . . . . .	28 50

PERFECTION WROUGHT IRON STANDS.

The Quadruple Stand has novel features. The cases on top project eight inches from the rack, giving the compositor plenty of knee room. The galleys between top cases are six inches wide, and divided into convenient spaces.

Perfection Quadruple Stand, with racks for 24 cases . . . . .	\$30 00
Perfection Quadruple Stand, with racks for 48 cases . . . . .	35 00
Perfection Double News Stand, with racks for 12 cases . . . . .	16 00
Perfection Double Book Stand, with racks for 24 cases . . . . .	20 00
Single News Stand, with racks for 8 cases . . . . .	10 00
Double Job Stand, with racks for 12 full-size and 12 two-third cases . . . . .	20 00
Double Stand (racks back to back), with racks for 12 cases . . . . .	16 00

Made for full-size, three-quarter or Rooker cases at the same prices.

WISCONSIN HARD-WOOD CABINETS

With "New Departure Cases."

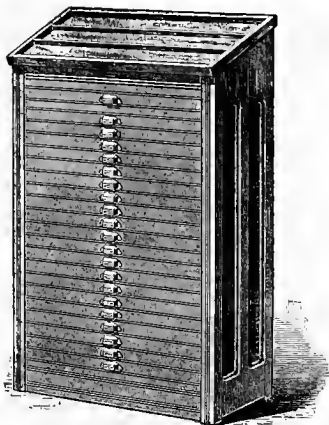

Twenty-Case Wisconsin Cabinet with Galley Top and Copy Drawer.

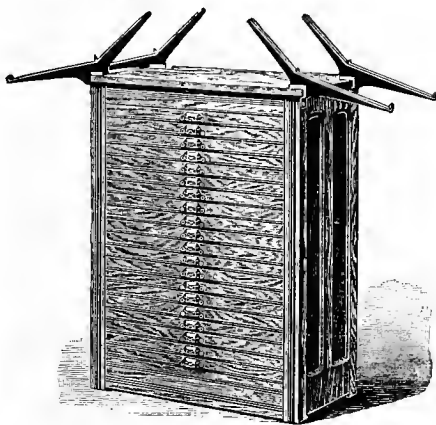

Twenty-Case Wisconsin Cabinet with Flat Top, showing Double Case Bracket, Style A\*, attached to top, for holding two pairs of cases.

Although made of hard wood, cherry finish, these cabinets are sold at the same prices as ordinary cheap-looking stained cabinets. Three-quarter and full-size cabinets are furnished with California job cases, described on page 48, which are preferable to Italic cases, as they afford more room for the caps. The bottoms are made flush with the floor, to prevent pi from getting underneath. The sides are double paneled and very tastefully moulded. Double case brackets may be put on top of the flat-top cabinets, making a very convenient stand, the regular height from the floor. *Galley-top Cabinets are kept in stock with twenty cases only, but can be furnished for twelve and sixteen cases to order, though not recommended.*

LIST PRICES.

	Flat Top.	Galley Top.
With 12 Two-third Job Cases	\$15 00	.
With 16 Two-third Job Cases	18 00	.
With 20 Two-third Job Cases	21 00	\$24 00
With 12 Three-quarter California Job Cases .	18 00	
With 16 Three-quarter California Job Cases .	22 00	.
With 20 Three-quarter California Job Cases .	26 00	29 00
With 12 Full-size California Job Cases	22 00	
With 16 Full-size California Job Cases	26 00	
With 20 Full-size California Job Cases . . . .	30 00	33 00

See page 560 for Blank Case Cabinets.

\* DOUBLE CASE BRACKETS, STYLE A,

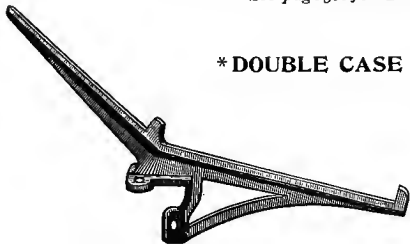

Which fit on top of flat-top cabinets, to hold a pair of cases, per pair. . . . \$1 50

For Brackets of all kinds, see page 564.

AMERICAN STEEL-RUN CABINETS

Hold 50 per cent. more type in same floor-space occupied by Regular 20-Case Cabinets.

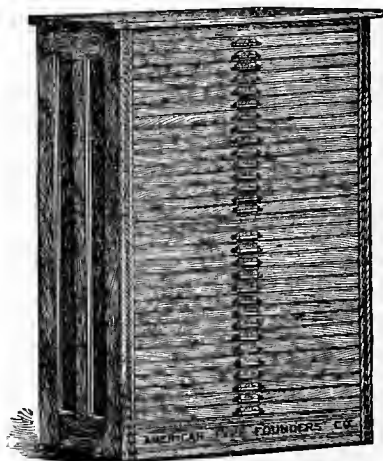

By substituting steel for wood in the runs, the awkward upper projections on the fronts of regular cabinet cases (which in the ordinary are put on to hide the wooden runs) are dispensed with, and ten more cases are got into the same space. Cases are easier to set out of, and *all cases are within easy reach of compositors of average height.*

The cabinets are made of hard wood, polished, braced in centre to prevent spreading, and California job cases (giving one-third more room for caps by dispensing with two superfluous rows of boxes) are used instead of Italic cases.

The height of the 30-case cabinets is 53 inches; of the 40-case, 68 inches. Cabinets can be supplied any height, but very high cabinets cannot be recommended owing to the loss of time in getting the top cases out of them.

Attention is directed to the common-sense assortment of cases in these cabinets. In thirty cases there will be required some cases for holding cap and small cap fonts.

The illustration herewith shows the steel run used in American Cabinets. Screws are countersunk.



Shows Steel-Run with Countersunk Screws.

LIST PRICES.

	Flat Top.	Galley Top.
30-case American Steel-Run Cabinet, with 25 two-third job and 5 two-third cap cases . . . . .	\$35 00	\$38 00
30-case American Steel-Run Cabinet, with 25 three-quarter California job and 5 three-quarter cap cases . . . . .	40 00	43 00
30-case American Steel-Run Cabinet, with 22 full-size California job, 5 full-size cap, and 3 full-size triple cases . . . . .	45 00	48 00
40-case American Steel-Run Cabinet, with 30 two-third job and 10 two-third cap cases . . . . .	48 00	52 00
40-case American Steel-Run Cabinet, with 30 three-quarter California job and 10 three-quarter cap cases . . . . .	53 00	57 00
40-case American Steel-Run Cabinet, with 30 full-size California job, 6 full-size cap, and 4 full-size triple cases . . . . .	60 00	64 00



PORTER'S PATENT EXTENSION FRONT  
STEEL-RUN CABINET.

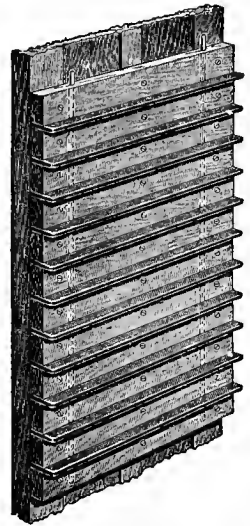
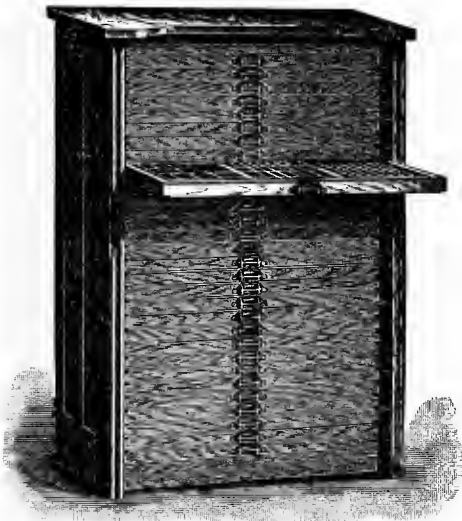

Shows construction of runs in Porter Cabinets. The steel runs are secured between wood, the wood screwed to sides, and two iron rods are passed through as extra strengtheners.

Notice the extension sides, the chief merit of this cabinet. These sides project out far enough to temporarily hold any of the cases the rack for which may be too high or too low for the convenience of the compositor.

The sides of these cabinets are extended four inches beyond the fronts of the cases. These extensions serve the printer in two ways: (1) A case near the top of a cabinet may be taken from its rack and placed in a more convenient position for setting from, and will be held by the extensions without withdrawing another case. This cannot be done on any other cabinet. (2) The extensions permit cases to be drawn out further from the racks than is possible in other cabinets, making it easier to set out of the rear boxes. In addition, these cabinets have all the best points of other cabinets, such as steel runs, "New Departure" cases, hard wood throughout, and are stronger than any other cabinets, as will be seen by examining the sectional illustration above.

The extension sides make it practicable to use higher cabinets, containing more cases in a tier, than can be advised where ordinary cabinets are used.

LIST PRICES.

No. 1, with 25 full-size California job cases, one tier, height 45 inches . . . . .	\$43 00
No. 2, with 30 full-size California job cases, one tier, height 53 inches . . . . .	51 00
No. 3, with 40 full-size California job cases, one tier, height 68 inches . . . . .	68 00
No. 4, with 50 full-size California job cases, one tier, height 84 inches . . . . .	85 00
No. 8, with 25 full-size blank cases, one tier, height 45 inches . . . . .	38 00
No. 9, with 30 full-size blank cases, one tier, height 53 inches . . . . .	45 00
No. 10, with 40 full-size blank cases, one tier, height 68 inches . . . . .	60 00
No. 11, with 50 full-size blank cases, one tier, height 84 inches . . . . .	75 00

Porter Cabinets of greater height can be supplied if desired. As all the above cabinets have flat tops, we do not list any double cabinets. A double 25-case (50 cases in all) will cost \$85; a double 30-case, \$100. Single tier, flat-top cabinets are always preferable to double, because it is easier to find positions for them. They are moved easier, and there is no saving in space by using double flat-top cabinets.

“AMERICAN-POLHEMUS” CABINETS.

All Hard Wood, Cherry Finish.

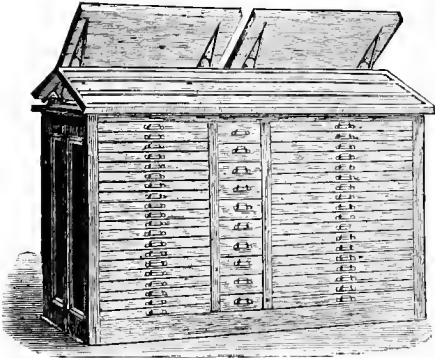

Front view of American-Polhemus Double Cabinet, showing Sort Drawers, Galley Top and Jobbing Cases.

The object of the American-Polhemus Cabinet is to save time and space. Time is lost on the ordinary cabinets by stationing the compositor in front of twenty cases, all frequently in use by other men, who, when setting or distributing from them, keep the man at the cabinet idle. On the American-Polhemus Cabinets the job cases are unobstructed, and the compositor stands at the back, where he cannot be interrupted. If he is setting solid matter he can empty his sticks, without walking a step, on a galley kept under his lower case, as the cases are held by the Patent Tilting Bracket and Galley Rest. Illustrated on page 58.

Every inch of space on the American-Polhemus Cabinets is utilized to advantage. The galley top or bank is a most useful addition. The space between the cases is used as a sort cabinet. The top is flat, and tied-up matter may be kept on it, as the iron case brackets admit of easy access to the space under the cases and galley top. The brackets which hold the cases project into the alley eight inches, giving the compositor plenty of knee-room, while saving floor-space.

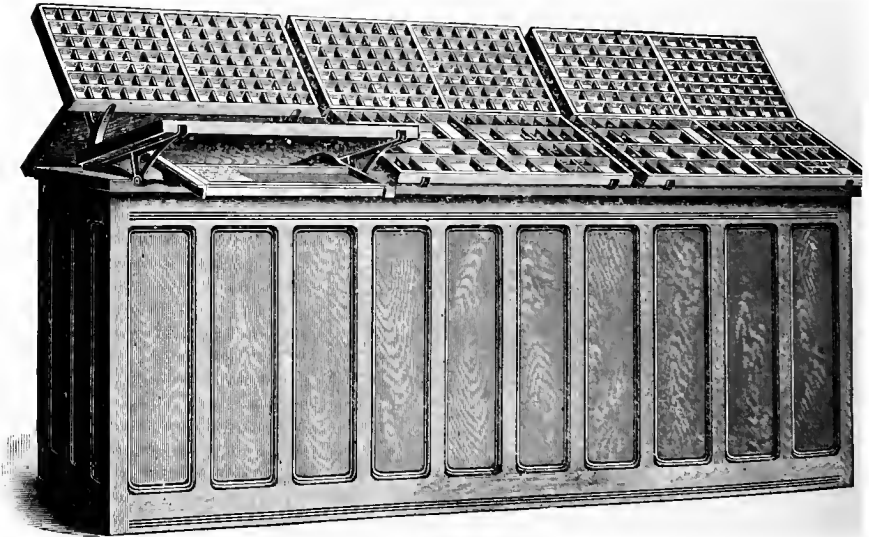

Back of American-Polhemus Triple Cabinet, showing arrangement of body-letter cases on the Patent Tilting Brackets.

**PRICES OF AMERICAN-POLHEMUS CABINETS.**

- Single American-Polhemus Cabinet—Complete with 18 full-size California job cases, 1 pair of news cases, galley top, and 1 pair of patent tilting brackets . \$35 00
- Double American-Polhemus Cabinet—Complete with 18 full-size and 20 three-quarter California job cases, 2 pairs of news cases, galley top, 10 sort drawers, and 2 pairs of patent tilting brackets . . . . . 75 00
- Triple American-Polhemus Cabinet—Complete with 18 full-size and 40 three-quarter California job cases, 3 pairs news cases, galley top, 10 sort drawers, and 3 pairs of patent tilting brackets . . . . . 110 00

**STEEL-RUN AMERICAN-POLHEMUS CABINETS.**

All Hard Wood, Cherry Finish.

These cabinets are similar to the American-Polhemus Cabinets, illustrated on these pages, except that the use of steel runs instead of wood runs increases their case-holding capacity without changing floor space or height.

- No. 5½. Double American-Polhemus Cabinet—Contains 18 full-size California job, 3 full-size triple, 4 full-size cap, 20 three-quarter California job, 5 three-quarter cap, and 2 pairs of full-size news cases on top, 10 sort drawers, a galley top, and 2 pairs of patent tilting brackets . . . . . \$95 00
- No. 6½. Double American-Polhemus Cabinet—Contains 43 full-size California job, 4 full-size cap, 3 full-size triple, and 2 pairs of full-size news cases on top, a galley top, and 2 pairs of patent tilting brackets (*no sort drawers*) . . . . . 95 00
- No. 7½. Single American-Polhemus Cabinet—Contains 19 full-size California job, 3 each full-size triple and cap cases, 1 pair of full-sized news cases on top, a galley top, and 1 pair of patent tilting brackets . . . . . 47 00

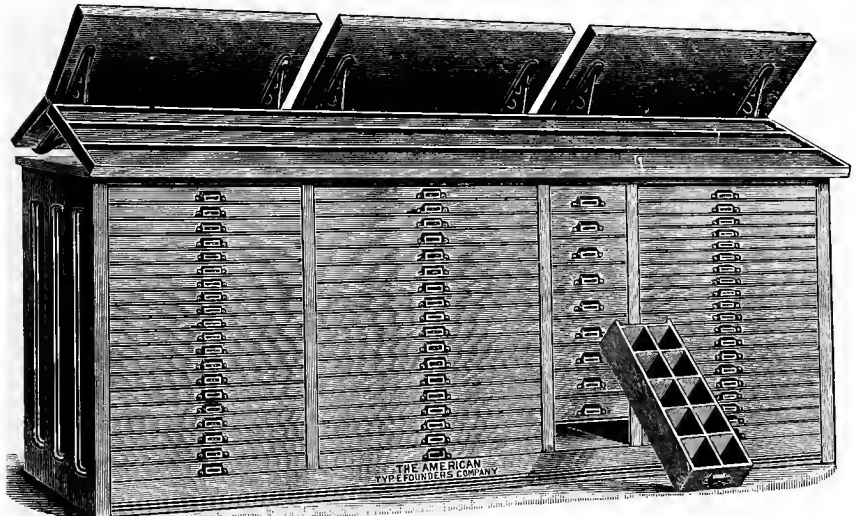

Front of American-Polhemus Triple Cabinet, showing Jobbing Cases, Sort Drawers, and Galley Top or Bank.

WISCONSIN WINDOW CABINET.

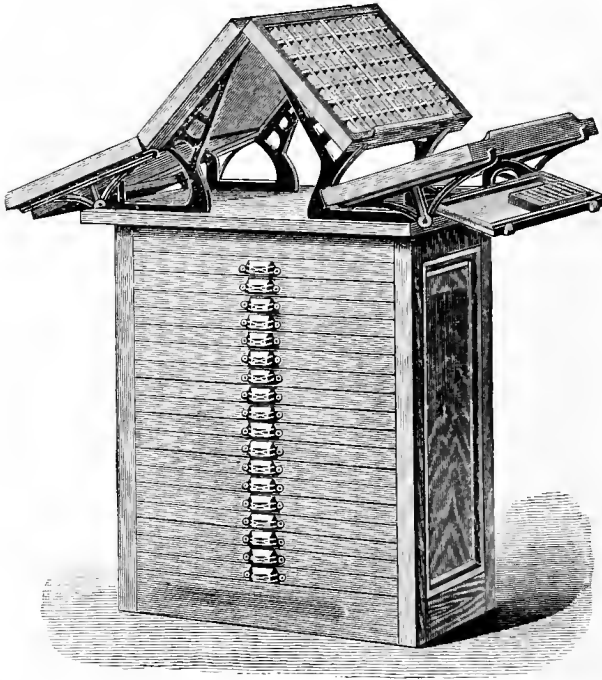

Specially designed for placing in front of a window, as it does not obstruct the light, of which the cases on top get the full benefit. Two men may work undisturbed at the sides, while the job cases in front are convenient for other men. The top is flat, and useful for holding tied-up type.

These cabinets have the patent tilting bracket and galley rest, which enables a compositor to empty his stick without leaving the cabinet by simply tilting his lower case, as shown in the cut, thus exposing the galley.

Wisconsin Window Cabinet, with two pairs of Patent Tilting Brackets and eighteen full-sized California job cases, two pairs of news cases on top, hard wood, cherry finish . . . . . \$36 00

PATENT TILTING CASE BRACKET.

Used on Wisconsin Window and American-Polhemus Cabinets.

B B (outline) shows bracket holding case in position for setting. Shaded cut shows bracket tilted up, allowing compositor to empty on galley below lower case, which is more clearly shown in cut of Wisconsin Window Cabinet printed above. These brackets are also supplied with all American-Polhemus Cabinets.

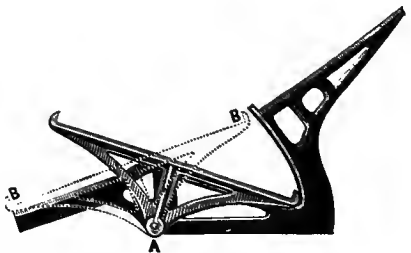

COMBINATION CABINET No. 1.

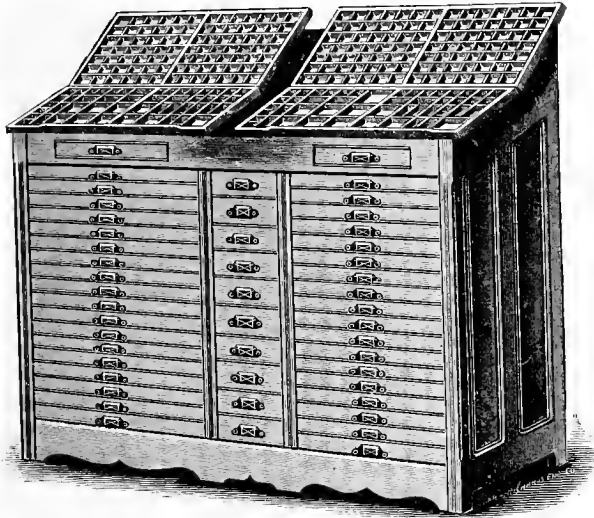

Made of hard wood, cherry finish. Contains 18 full-size California job, 18 two-third job, 2 pairs full-size news cases on top, 2 copy drawers, and 10 sort drawers with partitions . . . . . \$75 00

EAGLE CABINET.

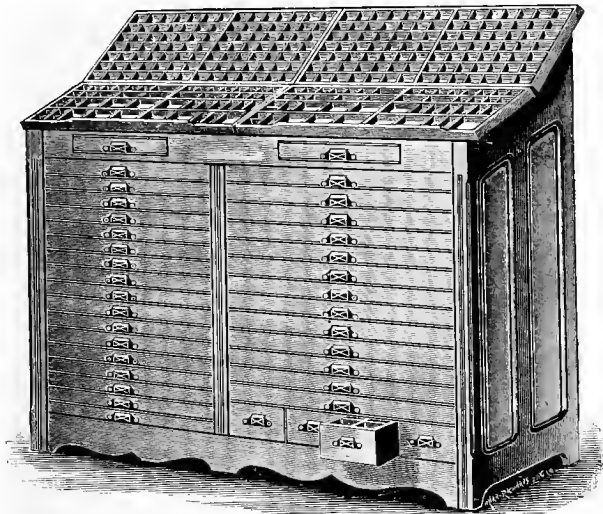

Made of hard wood, cherry finish. Contains 40 cases in all, including 12 full-size California job, 2 each full-size triple and cap cases, 20 three-quarter California job cases, 2 pairs full-size news cases on top, and 2 copy drawers . . . \$70 00

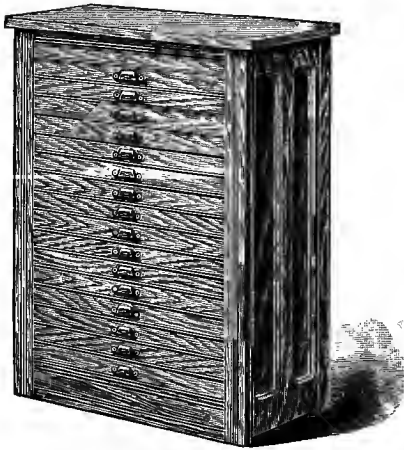

Flat-Top Sixteen-Case Electro Cabinet.

## ELECTRO AND CUT CABINETS.

These cabinets are filled with blank cases, and are made of polished ash, antique oak finish, with bronze case-pulls. The cases have extension backs. In addition to the ordinary use of the printer, these cabinets can be recommended to advertisers for keeping their wood cuts, etc., for keeping samples of hardware, confectionery, fancy stationery, for seeds, and many other purposes.

All sizes can be supplied with galley tops at an advance of \$3.00 on flat-top prices, but galley tops are not recommended except on 20-case cabinets.

	Size of Case. Inches.	Height of Cabinet.	With Flat Top.	Galley Top.
12 Two-third Blank Cases	. 16×21¾	34 inches	\$12 00	. .
16 Two-third Blank Cases	. 16×21¾	42 inches	14 00	.
20 Two-third Blank Cases	. 16×21¾	50 inches	16 00	\$19 00
12 Three-quarter Blank Cases	. 16×26¼	34 inches	15 00	.
16 Three-quarter Blank Cases	. 16×26¼	42 inches	18 00	.
20 Three-quarter Blank Cases	. 16×26¼	50 inches	21 00	24 00
12 Full-size Blank Cases .	. 16×32¼	34 inches	19 00	.
16 Full-size Blank Cases .	. 16×32¼	42 inches	22 00	. . .
20 Full-size Blank Cases .	. . . 16×32¼	50 inches	25 00	28 00

## SPECIMEN CABINETS.

Made in ash, with antique oak finish. These cabinets are handsomely made, and will be an ornament to any office.

The drawers have movable partitions, and are made in two depths—2½ inches and 5 inches. The No. 1 Cabinet is the proper height for placing a letter-copying press on.

The methodical classification and preservation of specimens in a cabinet enables customers to decide on what they want quickly, and in many cases suggests other requirements. Let the public see what you have to sell, and they will become buyers.

No. 1, 8 drawers, 26 inches wide by 19 inches deep by 42 inches high . . . \$14 00

No. 2, 12 drawers, 26 inches wide by 19 inches deep by 50 inches high . 20 00

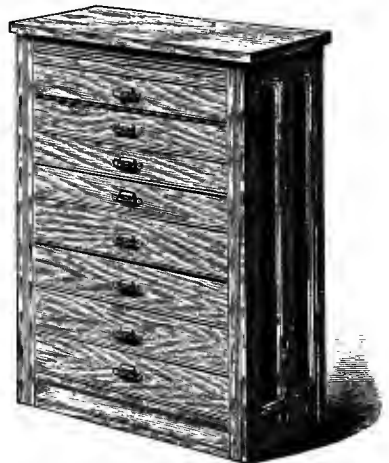

No. 1 Specimen Cabinet, 26 inches wide, 42 inches high, and 19 inches deep.

### WOOD-TYPE CABINETS.

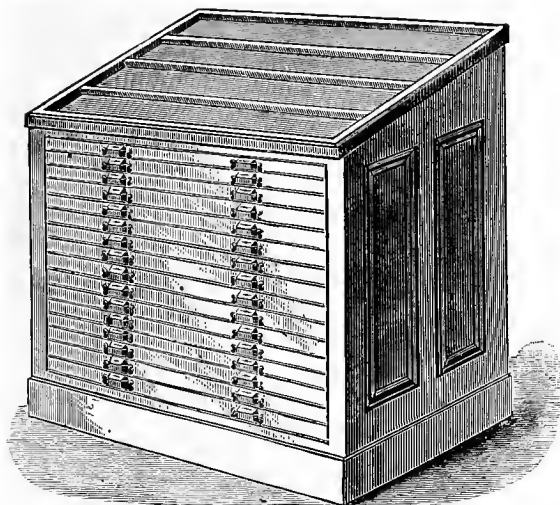

Very substantially constructed of hard wood, cherry finish. The cases are slotted on the sides, and have movable strips which may be adjusted to Picas. The cases in the Mammoth Cabinet (23 × 44 inches) have a center bar, and cases in the Regular Cabinet (23 × 32 inches) have no center bar.

These cabinets afford the most economical method of keeping wood type. The top of cabinet is available for use in laying out lines. They save the time lost in climbing to shelves, and the wood type is kept clean and is less liable to warp.

No. 5 Wood-Type Cabinet, with Galley Top. Occupies nine square feet floor space, and affords one hundred and twelve square feet for storage of type.

		Flat Top.	Galley Top.
No. 1.	12 cases, 23 × 32 inches . . . . .	\$20 00	\$23 00
No. 2.	16 cases, 23 × 32 inches . . . . .	25 00	28 00
No. 3.	20 cases, 23 × 32 inches . . . . .	30 00	33 00
No. 4.	12 cases, 23 × 44 inches . . . . .	25 00	28 00
No. 5.	16 cases, 23 × 44 inches . . . . .	33 00	36 00
No. 6.	20 cases, 23 × 44 inches . . . . .	40 00	45 00

### WOOD-TYPE CASE RACK.

To hold twenty No. 3 Wood-Type Cases (made to order) . . . . . \$9 00

For prices of Wood-Type Cases, see page 545. No. 3 Wood-Type Cases are 23 × 44 inches over all, and the price is \$1 30 each.

### BOOKBINDERS' CABINETS.

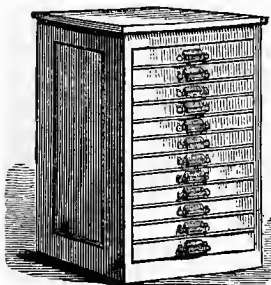

Made of hard wood, cherry finish, with bronzed pulls on each case. The cases are made in exactly the same style as printers' cases. These cabinets occupy a space of 20 × 20 inches, and may be put on or under a bench. "A place for everything and everything in its place" is a rule bookbinders should live up to, and these cabinets enable them to do so.

- Cabinets with 6 cases . \$ 8 00
- Cabinets with 10 cases . 12 00
- Cabinets with 15 cases . 16 50

### BOOKBINDERS' CASE.

Half Cap Case, 16 × 16 1/4 inches, without bronze pull, each . . . . . \$0 60



Case used in Bookbinders' Cabinet.

ROWEN BORDER AND SCRIPT TYPE CABINETS.

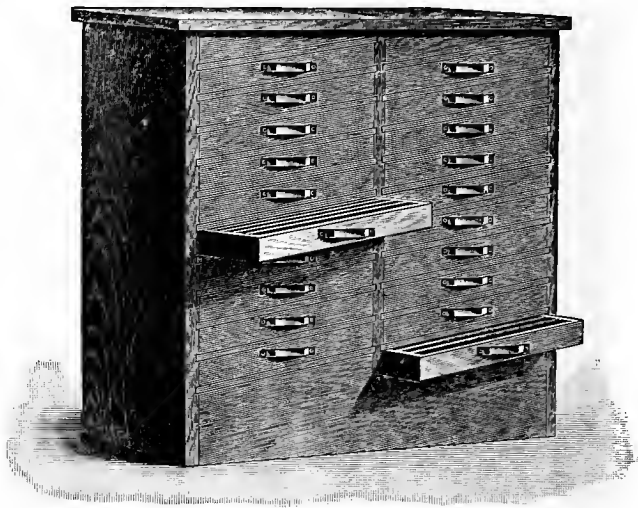

Rowen Border Cabinet with Twenty Cases.

These cabinets supply the long-felt need of a proper receptacle for borders, keeping them in compact shape and preserving the face.

The cases in these cabinets are 10 x 12 inches inside, and are tilted sufficiently to keep the type on its feet. The borders or type are held between movable division strips, which are 18 Points wide, while the slots into which these strips fit are set 6 Points apart, so that they can be adjusted to hold 6, 12, 18, 24, 30, 36, 42, 48, 54, 60, or 72 Point bodies, while such irregular and seldom-used bodies as 8 and 9 Point may be carried in the 12-Point drawers, or special strips may be procured for them.

For script type a quantity of metal pinch springs is furnished with each cabinet, for inserting between the different letters in a font, so that if all the letters "d" are removed, the pinch spring holds the letters "e" on their feet. The advantages of keeping delicate scripts in cases where the faces of the letters are not subject to friction and scratching will be apparent to all.



Rowen Border and Script Type Cabinet with Four Drawers.

LIST PRICES.

No. 1, 4 drawers, one tier, height 12 inches . . . . .	\$ 8 00
No. 2, 6 drawers, one tier, height 16 inches . . . . .	10 50
No. 3, 10 drawers, one tier, height 25 inches . . . . .	16 00
No. 4, 16 drawers, two tiers, height 21 inches . . . . .	25 00
No. 5, 20 drawers, two tiers, height 25 inches . . . . .	30 00
No. 6, 30 drawers, two tiers, height 35 inches . . . . .	45 00
No. 7, 40 drawers, two tiers, height 44 inches . . . . .	60 00

Each case will hold 30 feet of 6-Point, or 24 feet of 12-Point, or 20 feet of 18-Point, or 17 feet of 24-Point, or 15 feet of 30-Point, or 13 feet of 36-Point borders.



## HANDY SORT CABINETS.

These cabinets are fitted with serviceable sort drawers which should supplant the various cigar-box-tin can arrangements which disgrace so many offices. The drawers are 8 X 20 inches over all, and two inches deep. The cabinets are very strong, made of hard wood, and remarkably low-priced. The drawers, which are also for sale separately, have movable partitions, and may be adjusted to the special requirements of any printing office. All drawers have strong bronze drawer-pulls, whether sold in cabinets or separately.

A picture of the drawer is shown below. Drawers are sold separately if required.



Handy Sort Cabinet, with Thirty Drawers.

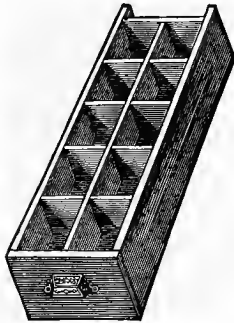

Cabinet with 10 Handy Sort Drawers . . . . .	\$12 00
Cabinet with 20 Handy Sort Drawers . . . . .	23 00
Cabinet with 30 Handy Sort Drawers . . . . .	35 00
Cabinet with 40 Handy Sort Drawers . . . . .	47 00
Cabinet with 50 Handy Sort Drawers . . . . .	59 00
<b>HANDY SORT DRAWERS, each . . . . .</b>	<b>0 90</b>

Sort Cabinets made to order to fit any space, or to any dimensions, at proportionate prices.

## PAPER AND CARD STOCK CABINETS.

Made very strongly of hard wood, cherry finish. High-priced papers and cardboard should be kept in a dust-tight receptacle, to prevent wastage and economize space. The drawers have extension backs, and are strongly constructed.

No. 1, 12 drawers, each drawer holding 22½ X 28-inch cardboard, or smaller.

Price . . . . . \$37 00

No. 2, 12 drawers, each drawer taking full sheet of 28 X 42 inches.

Price . . . . . \$48 00

The cabinets are 48 inches high. The drawers are 2½ and 5 inches deep, and have movable partitions.



No. 1 Paper Stock Cabinet. Occupies 26 X 34 inches floor space.

**CHALLENGE LAMP HOLDER.**

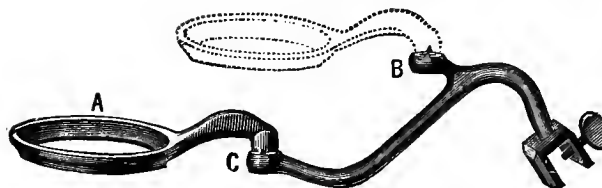

A most convenient and safe attachment for holding a lamp over the compositor's case. It will be readily understood by reference to the cut that the fount holder A can be instantly raised from C to B, as shown by the dotted lines, to adapt the position of the light to suit the compositor. Small thumb screws at

the top of B and C, with suitable recesses in A, retain the light perfectly stationary in any position.  
Each . . . . . \$0 75

**BRACKETS.**

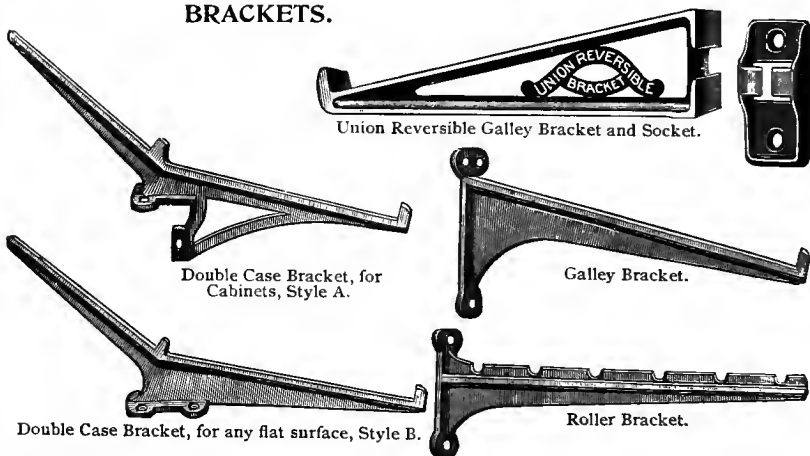

Union Reversible Galley Bracket and Socket.

Double Case Bracket, for Cabinets, Style A.

Galley Bracket.

Double Case Bracket, for any flat surface, Style B.

Roller Bracket.

- |   |        |
|---|--------|
| Double Case Brackets, style A, fit on end of Flat Top Cabinet, per pair . . . . . | \$1 50 |
| Double Case Brackets, style B, fit on any flat surface, per pair . . . . .        | 1 25   |
| Single Case Brackets, per pair . . . . .  | 0 75   |
| Galley Brackets, per pair . . . . .   | 0 40   |
| Roller Brackets, to hold six platen press rollers, per pair . . . . .             | 0 50   |
| Union Reversible Galley Brackets, with Sockets, per pair . . . . .                | 0 60   |
| Union Reversible Galley Brackets, with Sockets, per dozen pairs . . . . .         | 6 00   |

**TYPE-HIGH GAUGE.**

Much time may be saved in the press room if the maker-up will test all electrotypes, and have those that are high or low brought to the proper height by an electrotyper, or do it himself, before the form goes to press. The wise employer should insist on the use of this Gauge.

Price, each. . . . . \$2 50

See Type-High Machine on opposite page, and Backing for Electrotypes on page 649.

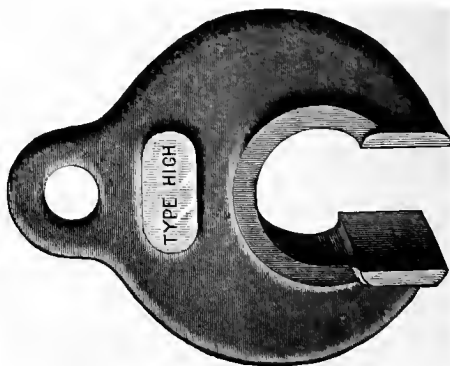

**PRINTERS' SAW TABLE,**

With Shoot-Board Attached.

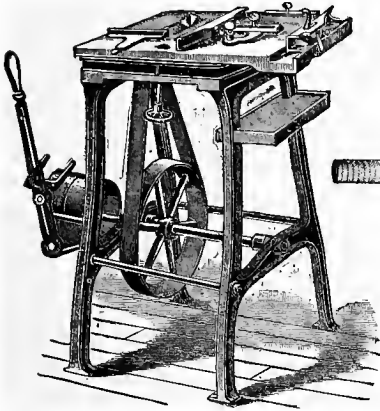

A very necessary machine in large printing offices. It will saw wood, metal or brass, and will trim wood and metal accurately from the merest shave upward. It affords the quickest and most accurate method of cutting slugs, furniture, thick brass rule and plates, and as it is fitted in the most complete manner with gauges, all trimming and cutting is done with perfect trueness and squareness. An attachment for cutting linotype slugs is furnished for \$15.00 extra.

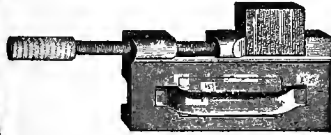

Attachment for Cutting Linotype Slugs.

Attachment for sawing linotype slugs is furnished for \$15.00 extra.

This is a thoroughly well-built machine, equal to similar machines used by electrotypers, made of iron and steel, with accurate adjustable gauges. The saw is raised or lowered by means of a clamp-screw set under the table. The countershaft is attached to the saw, and should not run less than four hundred revolutions per minute. The driving pulley is 7 inches in diameter, for 2 1/2-inch belt. Size of table is 18x24 inches, height 40 inches, and floor space occupied 24x32 inches.

lowered by means of a clamp-screw set under the table. The countershaft is attached to the saw, and should not run less than four hundred revolutions per minute. The driving pulley is 7 inches in diameter, for 2 1/2-inch belt. Size of table is 18x24 inches, height 40 inches, and floor space occupied 24x32 inches.

Saw table with shoot-board . . . . .	\$85 00
Saw table without shoot-board . . . . .	70 00
Attachment for sawing linotype slugs, extra . . . . .	15 00

**CHALLENGE TYPE-HIGH MACHINE.**

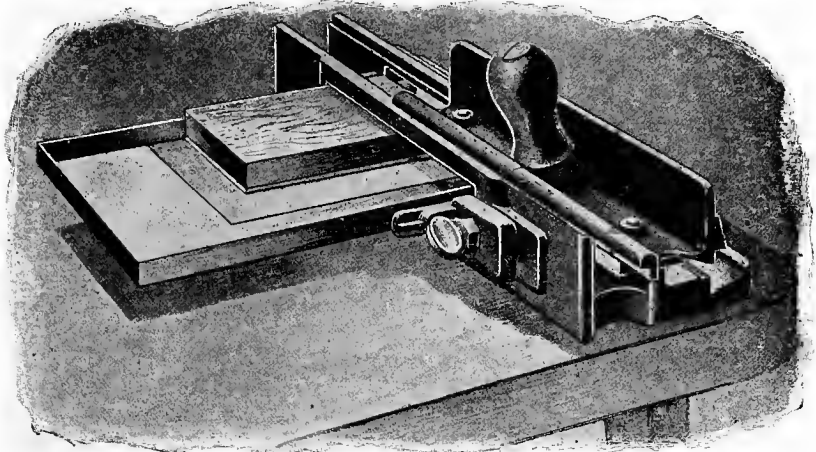

For reducing cuts to type-high, and making them true and even when warped, and for squaring cuts. Full directions with each machine. Descriptive circular on application. Price . . . . . \$12 00

*For Type-High Gauge, see opposite page.*

**GALLEY PROOF PRESSES.**

**AMERICAN PROOF PRESS.**

Built in the most substantial manner, thoroughly braced, with accurate bed and cylinder. The cylinder is much heavier than on the average proof press, and consequently gives a much better impression. The best proof press made.

**With Iron Stand.**

- No. 1, 10×31 inches inside . . . \$30 00
- No. 2, 16×31 inches inside . . . 42 00

**Without Stand.**

- No. 1A, 10×31 inches inside . . . \$22 50
- No. 2A, 16×31 inches inside . . . 30 00

Each proof press is furnished with blanket, brayer frame and stock.

**CHALLENGE PROOF PRESS.**

Lighter frame and lighter cylinder than the American Proof Press. The best low-priced proof press in the market, and equal to many listed at higher prices.

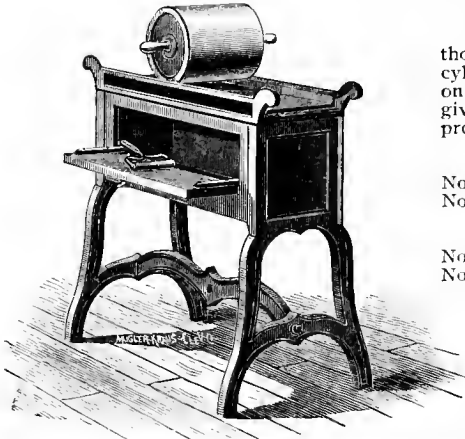

American Proof Press.

- 10×31 inches inside . . . . . \$27 00
- Each proof press is furnished with blanket, brayer frame and stock.

**RELIANCE JOB GALLEY PRESS.**

Designed for taking proofs of job work.

- No. A, without table, takes 14×20 job galley . . . \$22 50
- No. B, without table, takes 15×22 job galley . . . \$25 00

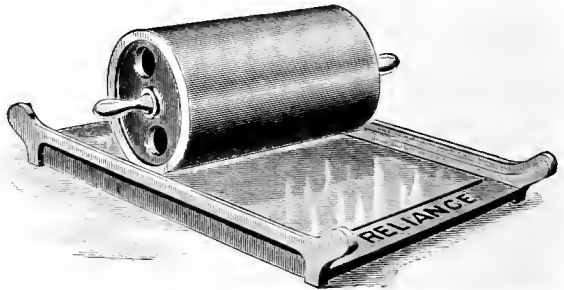

This is the cheapest proof press made. It has no bed, but consists of a roller and braced side frame.

**ECONOMIC PROOF PRESS.**

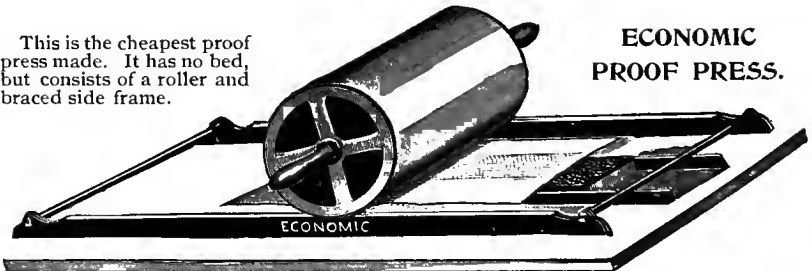

- A mould is provided for casting weights which can be placed inside the cylinder to increase pressure according to character of the work.
- 10×34 inches inside, complete with blanket and weight mould . . . . . \$13 50

**WEBB SUCCESS  
SELF-INKING PROOF PRESS.**

Prints from One or Two Rolls of Paper.

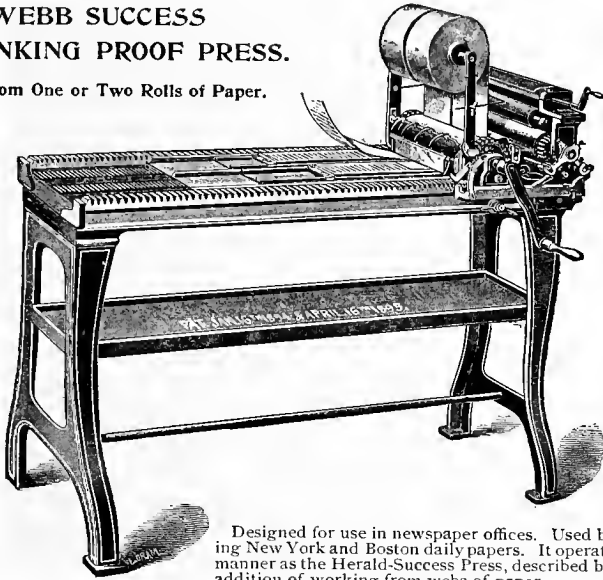

Designed for use in newspaper offices. Used by all the leading New York and Boston daily papers. It operates in the same manner as the Herald-Success Press, described below, with the addition of working from webs of paper.

- With 10-inch bed, for one web of paper, for proving single, double or triple-column galley . . . . . \$300 00
- With 12-inch bed, designed for taking two webs and taking two single-column galley proofs at once, or double, triple or quadruple column proofs by using wider single webs . . . . . 400 00

**HERALD-SUCCESS  
SELF-INKING  
PROOF PRESS.**

In use in the government printing offices of United States and Canada.

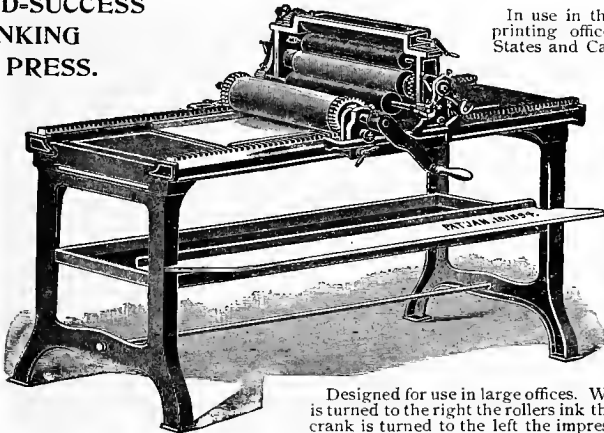

Designed for use in large offices. When the crank is turned to the right the rollers ink the forms, when crank is turned to the left the impression is taken. All movements are automatic. Impression cylinder

- is covered with seamless vulcanized rubber, taking clean and sharp impressions.
- With 18-inch bed, capable of proving four single-column galley at one impression, or large magazine pages . . . . . \$300 00
- With 24-inch bed, adapted for full-page newspaper proofs . . . . . 400 00

STANDING GALLEYS.

Made to Order.

Buyers may have these made to any dimensions they desire, at prices proportionate to those quoted below for the sizes and styles commonly used.

The space underneath may be utilized in various ways. In place of the case racks, as shown in the cuts, galley shelves and racks or letter boards can be put in. In ordering Standing Gallies, or in sending for estimates of cost, it is necessary to be *explicit* as to measurements and other requirements.

The regular width of single columns is three inches; of double columns, six inches; but these may be varied. The column strips are made of the same material as ordered for the top.

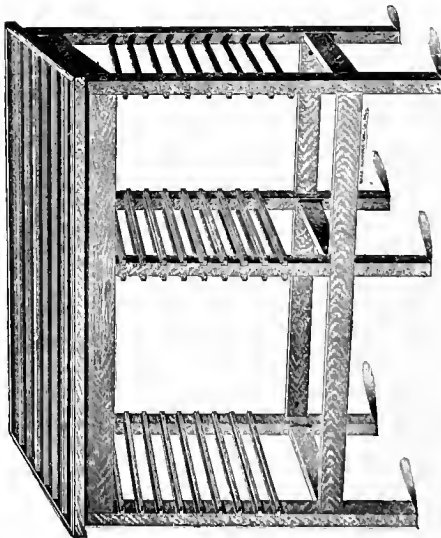

No.	Length Over All.	Material Used on Top.	What the Racks Hold.	5 Single Columns. Top 20 ins. wide.	6 Single Columns. Top 23½ ins. wide.	7 Single Columns. Top 27 ins. wide.	8 Single Columns. Top 30½ ins. wide.	8 Single Columns. Top 34 ins. wide.	10 Single Columns. Top 37½ ins. wide.
1	5 feet	Hard-wood Top, with wooden strips	8 each full and two-third cases	\$14 75	\$15 25	\$15 75	\$16 25	\$16 75	\$17 25
1A	5 feet	Hard-wood Top, with brass strips.		27 50	21 00	22 50	24 00	25 75	27 50
2	6 feet	All-brass Top	8 each full and two-third cases and 14 galley racks	16 00	16 55	17 10	17 65	18 90	18 75
2A	6 feet	Hard-wood Top, with wooden strips		24 75	24 00	25 50	27 00	28 75	30 50
2B	6 feet	All-brass Top	14 galley racks	31 00	34 50	38 00	41 50	45 00	48 50
3	7 feet	Hard-wood Top, with wooden strips		26 80	29 45	30 10	30 75	31 40	32 05
3A	7 feet	Hard-wood Top, with brass strips.	16 full-size cases	26 75	27 50	29 50	31 00	32 75	34 50
3B	7 feet	All-brass Top		33 50	39 50	43 50	47 50	51 50	55 50
4	8 feet	Hard-wood Top, with wooden strips	16 full-size cases and 14 galley racks	23 50	24 25	25 00	25 75	26 50	27 25
4A	8 feet	Hard-wood Top, with brass strips.		31 75	34 50	34 50	37 75	39 50	41 50
4B	8 feet	All-brass Top	24 full-size cases	42 00	46 50	51 00	55 50	60 00	64 50
5	10 feet	Hard-wood Top, with wooden strips		25 25	28 25	27 25	28 25	29 25	30 25
5A	10 feet	Hard-wood Top, with brass strips	32 full-size cases	35 75	38 50	40 50	42 00	43 75	45 50
5B	10 feet	All-brass Top		49 50	54 75	61 00	65 25	70 50	75 75
6	12 feet	Hard-wood Top, with wooden strips		29 50	30 65	31 80	32 95	34 10	35 25
6A	12 feet	Hard-wood Top, with brass strips.		40 75	43 50	45 75	48 00	50 75	53 50
6B	12 feet	All-brass Top		57 75	64 50	71 25	78 00	84 75	91 50

STANDING GALLEY WITH LETTER BOARDS.

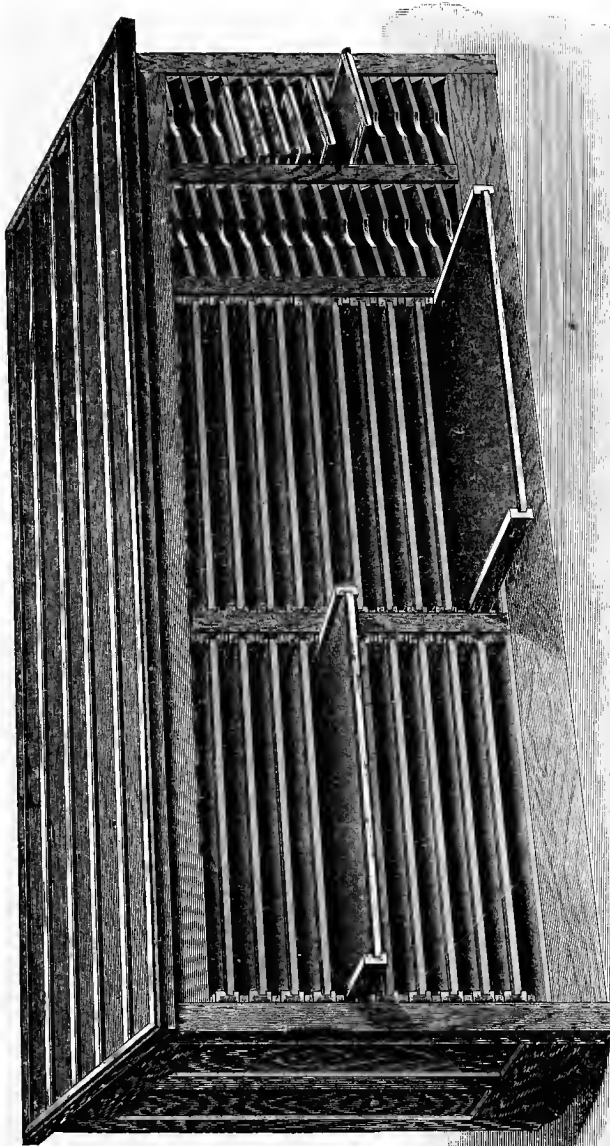

Contains 20 hard-wood letter boards, size of each  $24 \times 30\frac{1}{2}$  inches inside, and racks for 26 triple-column galleys; or, if galley racks are not needed, 10 letter boards, each  $24 \times 21$  inches inside, will be furnished instead at the same price. The brass-top style is covered with a single sheet of finest hard-rolled brass, and all division strips are lined with brass. Length, 8 feet; depth, 27 inches. Height in front, 3 feet; at back, 3 feet 10 inches.

No. 10, unlined, wood top . . . \$60 00 | No. 11, zinc-lined top . . . \$80 00 | No. 12, brass-lined top . . . \$90 00

## WROUGHT IRON HORIZONTAL STANDING GALLEY.

With All-Brass Top.

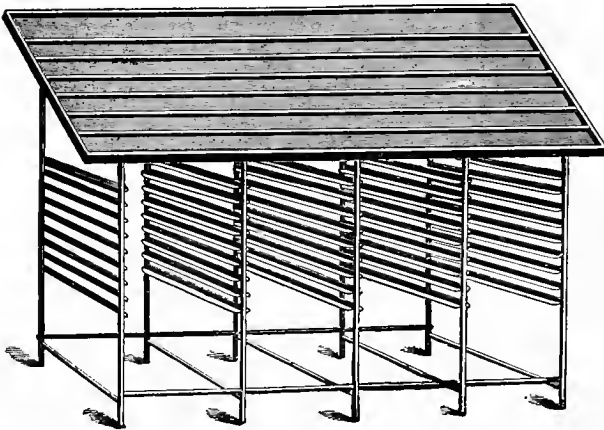

The Wrought Iron Standing Galleys, with columns running horizontally (see cut), have iron racks and all-brass tops. The brass strips screwed on top are L-shaped, making the partitions only a little wider than column width, but leaving enough room for the fingers to lift the type, thus reducing the width of the top, making it more convenient to reach the upper rows. The columns are made to any desired length and width.

The cut on this page is an illustration of the No. 6 size, which is 12 feet long, with iron racks for 32 full-size cases.

No.	Length of Rack.	What the Racks Hold.	5 Single Columns.	6 Single Columns.	7 Single Columns.	8 Single Columns.	9 Single Columns.	10 Single Columns.
1	5 feet	8 two-third and 8 full-size cases . . .	\$54 00	\$58 00	\$62 00	\$66 00	\$70 00	\$74 00
2	6 feet	8 two-third and 8 full-size cases and 16 galley racks . . .	70 00	75 00	80 00	85 00	90 00	95 00
3	7 feet	16 full-size cases . . .	65 00	71 00	77 00	83 00	89 00	95 00
4	8 feet	16 full-size cases and 16 galley racks . . .	80 00	86 00	92 00	98 00	104 00	110 00
5	10 feet	24 full-size cases . . .	85 00	92 00	99 00	106 00	113 00	120 00
6	12 feet	32 full-size cases . . .	95 00	104 00	113 00	122 00	131 00	140 00

## WROUGHT IRON LONGITUDINAL STANDING GALLEY.

With All-Brass Top.

Made entirely of brass and wrought iron. The top is covered with sheet brass, and screwed on the hard-wood top from underneath.

Standing Galleys with columns running longitudinally are designed for dead matter, and are almost indispensable. Uniform distribution is guaranteed, as the compositor is compelled to take the type from the top, and gets it into the cases regularly; consequently the type gets an even wear. The front is provided with a channel or gutter for the water used in wetting the type to run off into a receptacle. Any size made to order.

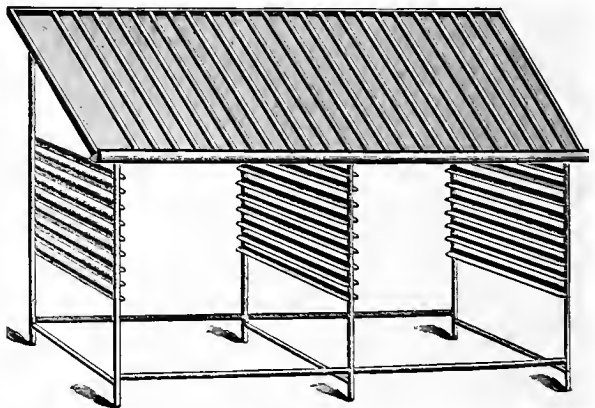

Wrought Iron Standing Galley, with All-Brass Top. This illustrates one 7 feet long and 26 inches wide.

Price, per single column, 26 inches deep, in banks not less than 5 feet long . . . \$3 50



## THORNE TYPE-SETTING AND DISTRIBUTING MACHINE.

Type-setting machines, long regarded as an experiment, are now as much of a necessity in the average printing office as cylinder presses, and publishers or printers having any considerable amount of plain book or news composition cannot afford in these days of competition and hurry to rely upon slow, laborious and expensive hand composition, when this simple, reliable, and moderate-priced machine is available, which will produce the same work in a perfect manner in half the time and at less than half the expense of hand work.

The Thorne Type-Setting Machine, using perfect type, produces results typographically equal, if not superior, to the work of the hand compositor; so that not only are these machines now in successful use on news and periodical work, but they are likewise constantly employed in the production of books requiring composition of the most exacting character.

The processes of distribution and composition are combined in a compact and simple machine of marvelous accuracy of construction, occupying but small floor space, and requiring little more power for its operation than a sewing machine.

The different processes of the work are under the instant and ready control of the operators; the distributor may be operated or stopped without interfering with the work of composition, and the setting of

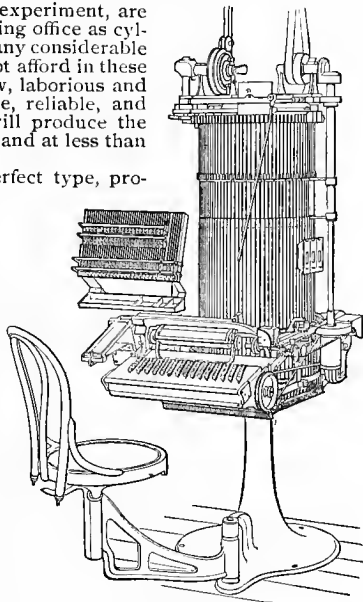

Front View.

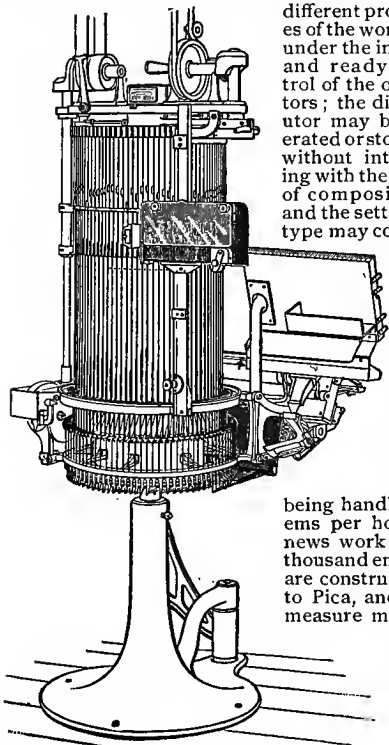

Back View.

type may continue so long as there is type for distribution. There being no time lost in distribution, composition may be carried on continuously should occasion require it, and it is a common practice to run machines with two sets of operators night and day.

Proficiency in operating the machine is readily acquired after short practice by printers, and no machinist is required in attendance, for all working parts are made interchangeable. When a part becomes worn or damaged it can be replaced by any one of average mechanical ability. The capacity of the machine is limited only by the proficiency of the operator, and the character of the work being handled; on book work from five to six thousand ems per hour are readily distributed and set, while on news work and work of similar nature from six to nine thousand ems are produced by expert operators. Machines are constructed to handle any one size of type from Agate to Pica, and for book work are so constructed that the measure may be changed in a minute's time. They are adaptable for use in any language, and machines are now employed by English, French, Finnish, Hebrew and German printers to set the type of newspapers, books and periodicals published in these languages. In the classes of work for which it is designed the machine will earn its cost within a few months.

Price, complete with all fixtures, f. o. b. Hartford, Conn. . . . . \$1500 00

# FOR THE PRESS ROOM.

## FELT BLANKETS.

Width.	Thick. Per Yard.	Thin. Per Yard.
36 inches . . . . .	\$5 40	\$2 75
40 inches . . . . .	6 00	3 00
44 inches . . . . .	6 60	3 25
48 inches . . . . .	7 25	
54 inches . . . . .	8 10	

Width.	Tbick. Per Yard.
56 inches . . . . .	\$8 50
58 inches . . . . .	8 75
60 inches . . . . .	9 00
62 inches . . . . .	9 50
65 inches . . . . .	9 75

## FELT BLANKETS.

Size Bed.	Size Blanket.	Thick. Each.	Thin. Each.
17×21 . . . . .	19×20 . . . . .	\$2 75	\$1 75
20×25 . . . . .	23×24 . . . . .	3 25	2 00
21×27 . . . . .	25×25 . . . . .	3 50	2 25
24×30 . . . . .	28×28 . . . . .	4 00	2 75
25×35 . . . . .	29×33 . . . . .	5 50	3 75
29×42 . . . . .	34×40 . . . . .	6 25	5 00
32×46 . . . . .	38×44 . . . . .	8 75	6 50
33×50 . . . . .	38×47 . . . . .	9 75	7 50
36×52 . . . . .	42×49 . . . . .	11 25	9 25
40×54 . . . . .	46×53 . . . . .	12 25	10 00

## RUBBER BLANKETS.

Size Bed.	Size Blanket.	Regular Thickness.
17×21 . . . . .	19×20 . . . . .	Each, \$3 00
20×25 . . . . .	23×24 . . . . .	Each, 4 25
21×27 . . . . .	25×25 . . . . .	Each, 4 75
24×30 . . . . .	28×28 . . . . .	Each, 5 75
25×35 . . . . .	29×33 . . . . .	Each, 6 50
29×42 . . . . .	34×40 . . . . .	Each, 8 75
32×46 . . . . .	38×44 . . . . .	Each, 10 50
33×50 . . . . .	38×47 . . . . .	Each, 11 75
36×52 . . . . .	42×49 . . . . .	Each, 13 25
40×54 . . . . .	46×53 . . . . .	Each, 17 00

## FELT BLANKETS FOR HAND PRESSES.

For 6-Column Newspaper . . . \$3 00  
For 7-Column Newspaper . . . 3 75

For 8-Column Newspaper . . . \$5 00  
For 9-Column Newspaper . . . 6 50

## ROLLER CLOTH.

In rolls 12 yds. long by 2½ in. wide, per roll . . . . . \$5 00

## RUBBER BLANKETS.

	2-Ply 1-16-Inch Thick.	3-Ply 1-12-Inch Thick.	5-Ply ¾-Inch Thick.	Tympan Rubber.
26 inches wide, per yard . . . . .	\$5 00	\$6 25	\$7 25	. . . . .
32 inches wide, per yard . . . . .	5 75	7 00	8 75	. . . . .
34 inches wide, per yard . . . . .	6 25	7 50	9 75	. . . . .
36 inches wide, per yard . . . . .	6 50	7 75	10 25	\$1 25
38 inches wide, per yard . . . . .	7 25	8 50	11 25	. . . . .
40 inches wide, per yard . . . . .	7 50	8 75	11 75	. . . . .
44 inches wide, per yard . . . . .	8 50	10 00	13 50	. . . . .
48 inches wide, per yard . . . . .	10 50	12 00	16 00	. . . . .

## TAPE.

¾-inch, per roll . . . . .	\$ 75	1-inch, per roll . . . . .	\$1 50
½-inch, per roll . . . . .	75	1¼-inches, per roll . . . . .	1 60
⅜-inch, per roll . . . . .	1 00	1½-inches, per roll . . . . .	1 75
¼-inch, per roll . . . . .	1 25	1¾-inches, per roll . . . . .	2 00
⅓-inch, per roll . . . . .	1 40		

A roll of tape contains thirty-six yards.

## TAPE FASTENER.

Fastens tape with eyelets, which are neatly clinched by the fastener.

Price, with box of eyelets . . . . . \$1 25



**TYMPAN PRESSBOARDS.**

21×29 inches, each . . . . .	\$0 50	35×52 inches, each . . . . .	\$1 25
26×35 inches, each . . . . .	0 75	40×56 inches, each . . . . .	1 50
29×42 inches, each . . . . .	1 00		

**METALLIC TAPE COUPLERS.**

This is a device for connecting ends of tape on presses and folding machines, so that there will be no wear at the joined parts, as is usual on sewed ends, which wear and cause the tape to run crooked and throw paper out of register. The Metallic Tape Coupler outlasts other methods of securing the ends of tape, and keeps the tape running true. It can be put on in a few seconds by means of Parallel Pliers made for that purpose.

PRICE PER BOX OF FIFTY.

No. 1, for ½-inch tape . . . . .	\$1 25	No. 4, for ¾-inch tape . . . . .	\$1 75
No. 2, for ⅝-inch tape . . . . .	1 50	No. 5, for 1-inch tape . . . . .	1 75
No. 3, for ¾-inch tape . . . . .	1 50	No. 6, for 1½-inch tape . . . . .	1 75

**SMOOTH-JAW PARALLEL PLIERS** (these pliers can be used for all sizes of couplers), per pair . . . . . 1 00

**LEATHER BELTING.**

Width.	Per ft.	Width.	Per ft.	Width.	Per ft.	Width.	Per ft.
1 inch . . . . .	\$0 12	2½ inches . . . . .	\$0 36	4 inches . . . . .	\$0 60	6½ inches . . . . .	\$1 00
1¼ inches . . . . .	0 16	2¾ inches . . . . .	0 40	4½ inches . . . . .	0 68	7 inches . . . . .	1 08
1½ inches . . . . .	0 20	3 inches . . . . .	0 44	5 inches . . . . .	0 76	8 inches . . . . .	1 24
1¾ inches . . . . .	0 24	3¼ inches . . . . .	0 48	5½ inches . . . . .	0 84	9 inches . . . . .	1 40
2 inches . . . . .	0 28	3½ inches . . . . .	0 52	6 inches . . . . .	0 92	10 inches . . . . .	1 56
2¼ inches . . . . .	0 32	3¾ inches . . . . .	0 56				

**PRINTERS' BRUSHES.**



Lye Brush.

	All Bristle		Tampico	
	Per Doz.	Each.	Per. Doz.	Each.
Lye Brush, medium . . . . .	\$5 00	\$0 50	\$3 50	\$0 40
Lye brush, large . . . . .	7 00	0 75	4 50	0 50



Benzine Brush, oval back.

Benzine Brush, all bristle, oval back, genuine "pick" brush . . . . . \$0 60



Benzine Brush, with handle.

Benzine Brush, all bristle, with handle . . . . . \$0 40

**PROOF AND STEREOTYPE BEATING BRUSHES.**

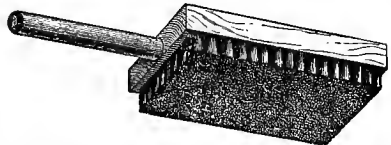

Ordinary Proof Brush . . . . . \$1 50  
Genuine Extra Stereotypers' Beating Brush, the best made, net . . . . . 7 00

**LIQUID CEMENT BRUSH.**

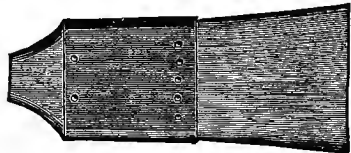

Made of French bristles, flat and double thick.

1 inch . . . . .	\$0 30
1½ inch . . . . .	0 40
2 inch . . . . .	0 55
3½ inch . . . . .	0 75

**PRINTERS' DIVIDERS.**



Useful for laying out paper, setting gauges and imposing plate forms.

Price . . . . . \$0 85

**INK KNIVES.**

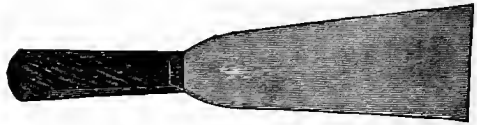

Style B.

6-inch blade, Style B	\$0 60
8-inch blade, Style B	1 00
10-inch blade, Style B	1 60

**WRENCHES.**



8-inch . . . . .	\$0 75
12-inch . . . . .	1 00

**PALLET INK KNIVES.**



Square end.

6-inch blade . . . . .	\$0 50
8-inch blade . . . . .	0 70
10-inch blade . . . . .	1 00

**PAPER FOLDERS.**

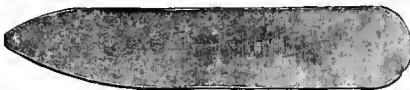

Also used for feeding cylinder presses.

Steel, nickel-plated, 6 x 1 1/8 inches, each . . . . .	\$0 50
Bone, each, 25 cents; per dozen . . . . .	2 50

**INK SLICE.**

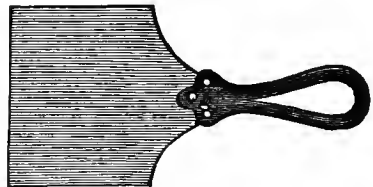

Brass handle, steel blade . . . . . \$0 75

**SCREW DRIVERS.**



Each . . . . . \$0 75

**OVERLAY KNIFE.**

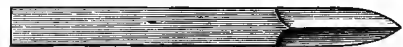

In leather case, 6 x 3/16 inch, nicked . \$0 60

**ST. JOHN PAPER KNIFE.**



Made of fine steel and suitably pointed for cutting paper. Upon the back of the blade is fixed a broad guard, shaped to fit the finger, by which the operator is enabled to cut much faster and more easily than with a common knife.

Price . . . . . \$0 50

**TABLET KNIFE.**



Made extra thin, for separating the tablets after they are removed from the press.

Price . . . . . \$0 50

**HICKORY SHOOTING STICKS.**



This is the only safe shooting stick to use on the bed of a cylinder press.

Price, each, 8 cents; per dozen . . . \$0 85

## GAUGE PINS AND GUIDES.

See explanation of Nos. below.

Original Steel Gauge Pins, Nos. 1, 2, 3, 4, per dozen	\$0 60
Golden Steel Gauge Pins, Nos. 1, 2, 3, 4, 5, 6, per dozen	0 40
Spring Tongue Gauge Pins, one size only, per dozen	1 20
Flexible Side Gauge Pins, per dozen	0 60
Perfect Register Gauge Pins, per set of three	1 25
Screw Adjusting Gauge Pins, one size only, per set of three	1 00
Extension Feed Guides, per pair	1 00
Cylinder Side Guides, each	0 50
Extra Tongues for Spring Tongue, "Perfect" or Screw Adjusting Pins, per dozen	0 25
Gauge Pin Drawers (see illustration on bottom of page), each	0 25

### EXPLANATION OF NUMBERS.

No. 1 gauges are 12 Points high, with lip  $\frac{1}{16}$ -inch long; No. 2, 15 Points high,  $\frac{1}{16}$ -inch lip; No. 3, 18 Points high,  $\frac{1}{16}$ -inch lip; No. 4, 12 Points high, short lip; No. 5, 15 Points high,  $\frac{1}{4}$ -inch lip; No. 6, 12 Points high,  $\frac{1}{4}$ -inch lip. All gauges with tongues are 12 Points high.

#### GOLDEN STEEL GAUGE PIN.



#### ORIGINAL STEEL GAUGE PIN.



#### PERFECT REGISTER GAUGE PIN.



Pastes on like a quad, has a thin steel clip which strikes into tympan and prevents sheets from slipping under gauges, and is adjustable after pasting on.

#### FLEXIBLE SIDE GAUGE PIN.



May be placed directly under gripper finger without injury to gauge or displacing it. The sheet is fed to the curved spring arm. Made of fine thin steel, with teeth underneath to prevent sheet from getting under gauge.

#### CYLINDER SIDE GUIDE.

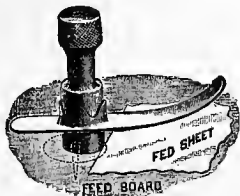

Secured to feed-board by the sharp point shown in outline in cut, which is placed at the side of pillar, so that hair adjustments may be got by simply turning the pillar to the desired position. The bendable brass tongue is adjustable in every direction.

#### SPRING TONGUE GAUGE PIN.



This is the most satisfactory gauge pin made—it meets almost every requirement of the pressman.

#### SCREW ADJUSTING GAUGE PIN.



The prong should be inserted a quarter inch below the feeding line and forced snugly home. The base may be secured to the tympan with paste or glue if desired. The adjustment is got by means of the screw and nut with absolute precision and without weakening the hold of the pin to tympan.

#### EXTENSION FEED GUIDES.

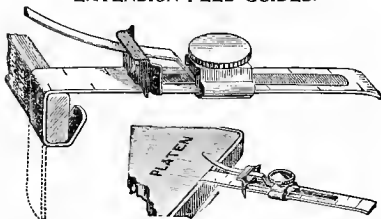

The cut shows the method of securing the guides between platen and platen bail, so that sheets may be fed below the lower edge of the platen.

#### GAUGE PIN DRAWER.

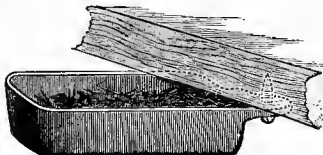

Screws on under the feed-board.

## SUCCESS SAFETY BENZINE CAN.

Made of Brass.

By the use of this safety can, leakage of benzine or its vapor is prevented, as the stopper is automatically self-locking—always tightly closed when the can is not in use. The flow of benzine, naphtha or any other fluid is regulated by the pressure of the second and third fingers upon a circular plate on the nozzle; and the adjustment is so perfect that one can pour a single drop, or a full stream, at will. It is also neat and cleanly, for the hands are kept entirely free from contact with its contents. The patent improved stopper is as durable as it is simple. Made of the best material, and carefully finished and adjusted.

As a safeguard against loss by fire, this can is an economical and profitable "policy." Benzine is dangerous, but its use is divested of risk where this improved can is employed. It has been put to the test, and proved safe and serviceable in every respect. It may be overturned or placed in any position whatever, and the contents will not spill or overflow. There are no chains or exposed springs.

Approved by the Board of Fire Underwriters.

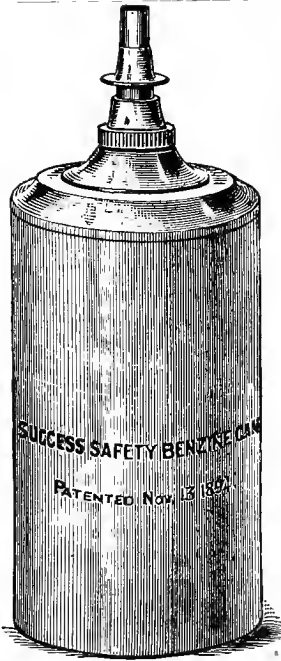

Quart can . . . . .	\$0 75
Gallon can . . . . .	2 00

## UNION STORAGE CAN.

For Holding Benzine or Oils.

It is strongly made of galvanized iron and is self-closing. There can be no evaporation, and no fluid can be spilled until the nozzle is opened by means of the spring. A very necessary article in all printing offices which are permitted to have one or more gallons of benzine on the premises.

Quite a saving in the cost of benzine and oils will be realized by purchasing in the quantities held by these storage cans, besides avoiding the inconvenience of sending out at frequent intervals to get the ordinary benzine can filled up.



1-gallon can . . . . .	\$2 00
3-gallon can . . . . .	2 50
5-gallon can . . . . .	3 00



## UNION SAFE BENZINE CAN.

This is patterned after the original benzine can, with the addition of a circular plate around the head, near the vent, by means of which the valve is opened without wetting the fingers. When pressure is removed it closes automatically. The head is attached to the can with a chain, so that it cannot be lost when unscrewed for the purpose of filling with benzine.



Made of tin.  
Enamelled red.

Holds one quart, each . . . . . \$0 75

**PRESS POINTS.**

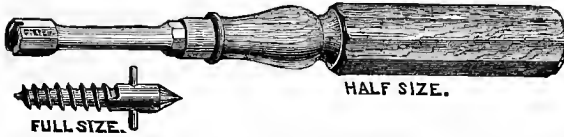

For inserting in wood furniture when sheets are printed for folding machine. Points are screwed into wood with wrench as far as the cross pin will allow, when they will be found to be correct height.  
 Points, per dozen . . . . \$0 75 | Wrench . . . . . \$0 75

**DILLINGHAM PRESS PUNCH.**

Patented March 2, 1897.

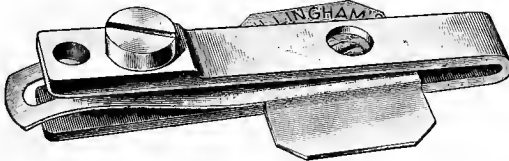

Is secured to the tympan of platen presses in same manner as a feed guide, and punches a clean hole in card or paper simultaneously with the printing on jobs which have

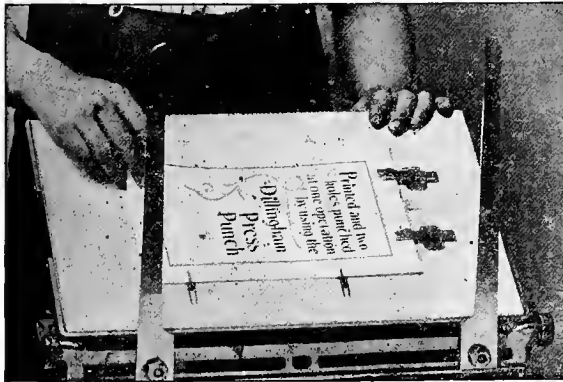

a margin of one inch or more. The method of working this punch is clearly shown in accompanying half-tone. The slightly curved spring is placed under the upper tympan sheet, and the sheet to be punched is fed over this curved spring and under the punch with no more trouble than in feeding to gange pins. The punch is secured to the



tympan by paste or glue or (better still) by

a mixture of paste and glue. Two or more punches can be used on one sheet. Punching and printing can be done simultaneously on a variety of work, such as window cards, programmes, orders of dance, souvenirs, etc. Made with large and small holes, as per diagram. The larger hole will be sent unless otherwise ordered.

Each, with directions, net . . . . . \$1 25

**PRESS PUNCH.**



This punch is about one thirty-second inch lower than type, and can be locked up in a type form, thus enabling printers to punch holes in stock at the same time it is printed, without extra expense. A piece of 2-point brass rule should be cemented to the tympan sheet for the punch to strike on, and an opening left in the form opposite opening in base of punch to prevent it from becoming clogged. Made of best tool steel, tempered.

For  $\frac{3}{8}$ ,  $\frac{3}{16}$ , or  $\frac{1}{4}$  inch hole, each . . . . . \$1 00

## MAHOGANY AND IRON STEREOTYPE BLOCKS.

Mahogany Blocks are made of the best San Domingo mahogany, thoroughly seasoned, and are first-class in every detail. All blocks are made to order at short notice.

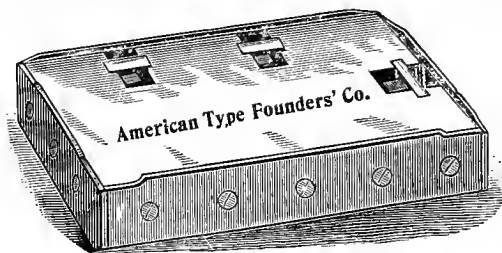

New Style Block, with Patent Side and End Hooks.

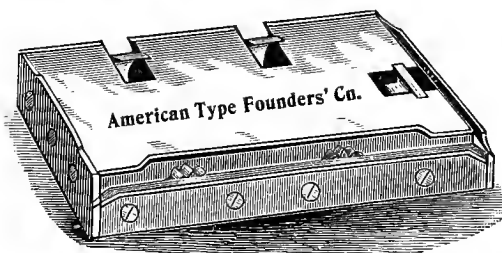

Improved Plain Old Style Block, with Patent End Hook.

### IMPORTANT POINTS.

Do not order a set of blocks, nor make up a form of patent blocks for press, until you know the exact size of chase that must hold the blocks, and the thickness and position of its cross-bars. Ascertain also the exact size of paper for which the blocks are intended, and whether the leaves of paper, after printing, are to be cut or uncut, and to be sewed or stitched. In making up blocks, if paper is to be uncut and sewed, allow nothing for loss by waste on the fore edge; if it is to be side-stitched and trimmed, make suitable allowance for margin that will be concealed by wire stitching in binding.

**CAUTION—To Avoid Errors.** In sending orders, give the size of each block outside, and also the size of largest and smallest plate to be worked, measuring the back of the plate; or add  $\frac{3}{4}$  of an inch to the printing matter, as follows, viz.: If the matter is  $3 \times 5$ , the blocks should be  $3\frac{3}{4} \times 5\frac{3}{4}$  outside, the bevel on the plate being about  $\frac{1}{8}$ . The hook and pinion will take  $\frac{5}{8}$  with a little allowance for taking the plate free. All blocks are made  $\frac{3}{4}$ -inch thick, unless otherwise ordered.

### WITHOUT END HOOKS, FOR PLATEN PRESSES.

To get the price of blocks with head brass, but no end hook, take the price of the next largest size in Price List. Add 50 cents each for extra hooks and pinions inserted in blocks.

SIZES.	Outside Dimensions of Blocks.	*Size of Smallest Plate including Bevel.	No. of Side Hooks.	Imp. Plain Old Style.	Patent New Style.	Patent New Style Iron.	Proper Number of Blocks to Work a Sheet of Paper.
Folio—							
Imperial . . .	16 × 22 $\frac{1}{2}$	14 $\frac{3}{4}$ × 21 $\frac{3}{4}$	4	\$5 00	\$6 25	\$16 00	4 blocks to 33 × 46
Super-Royal . . .	13 $\frac{1}{2}$ × 21 $\frac{1}{2}$	12 $\frac{3}{4}$ × 20 $\frac{3}{4}$	4	4 55	5 70	15 00	2 blocks to 22 × 28
Royal . . .	12 $\frac{1}{2}$ × 19 $\frac{1}{2}$	11 $\frac{1}{4}$ × 18 $\frac{1}{4}$	4	4 20	5 25	14 00	4 blocks to 26 × 40
Medium . . .	11 $\frac{1}{2}$ × 18 $\frac{1}{2}$	10 $\frac{3}{4}$ × 17 $\frac{3}{4}$	4	3 90	4 80	13 00	4 blocks to 24 × 38
Quarto—							
Imperial . . .	11 × 16	9 $\frac{3}{4}$ × 14 $\frac{3}{4}$	4	3 75	4 50	12 00	8 blocks to 33 × 46
Super-Royal . . .	10 $\frac{1}{2}$ × 13 $\frac{1}{2}$	9 $\frac{3}{4}$ × 12 $\frac{3}{4}$	3	3 10	3 75	10 50	4 blocks to 22 × 28
Royal . . .	9 $\frac{1}{2}$ × 12 $\frac{1}{2}$	8 $\frac{3}{4}$ × 11 $\frac{3}{4}$	3	2 95	3 50	10 00	8 blocks to 26 × 40
Medium . . .	9 × 11 $\frac{1}{2}$	7 $\frac{3}{4}$ × 10 $\frac{3}{4}$	3	2 80	3 30	9 50	8 blocks to 24 × 38
Octavo—							
Imperial . . .	7 $\frac{3}{4}$ × 11	6 $\frac{1}{2}$ × 9 $\frac{3}{4}$	3	2 65	3 10	9 00	16 blocks to 33 × 46
Super-Royal . . .	6 $\frac{1}{2}$ × 10 $\frac{1}{2}$	5 $\frac{1}{4}$ × 9 $\frac{1}{4}$	3	2 50	2 90	8 50	8 blocks to 22 × 28
Royal . . .	6 × 9 $\frac{1}{2}$	4 $\frac{3}{4}$ × 8 $\frac{1}{4}$	3	2 40	2 75	8 00	16 blocks to 26 × 40
Medium . . .	5 $\frac{1}{2}$ × 9	4 $\frac{1}{4}$ × 7 $\frac{1}{4}$	3	2 30	2 60	7 75	16 blocks to 24 × 38
Demy . . .	5 $\frac{1}{4}$ × 7 $\frac{3}{4}$	4 × 7 $\frac{1}{2}$	3	2 20	2 45	7 50	32 blocks to 23 × 46
Duodecimo—							
Broad . . .	5 $\frac{1}{4}$ × 6 $\frac{3}{4}$	4 × 5 $\frac{1}{2}$	2	1 65	1 90		24 blocks to 23 × 41
16mo—							
Super-Royal . . .	5 × 6 $\frac{1}{2}$	3 $\frac{3}{4}$ × 5 $\frac{1}{4}$	2	1 50	1 70		16 blocks to 22 × 28
Medium . . .	4 $\frac{1}{2}$ × 6	3 $\frac{1}{4}$ × 4 $\frac{1}{4}$	2	1 40	1 60		32 blocks to 26 × 40
Demy . . .	3 $\frac{3}{4}$ × 5 $\frac{1}{4}$	2 $\frac{1}{2}$ × 4	2	1 30	1 50		32 blocks to 23 × 33
18mo—							
Medium . . .	3 $\frac{1}{2}$ × 5 $\frac{1}{4}$	2 $\frac{1}{4}$ × 4 $\frac{1}{2}$	2	1 30	1 50		18 blocks to 19 × 24
32mo—							
Super-Royal . . .	3 × 5	1 $\frac{3}{4}$ × 3 $\frac{3}{4}$	2	1 20	1 40		32 blocks to 22 × 28

\* A block will take on a plate  $\frac{3}{4}$ -inch smaller each way than its outside dimensions.



WITH END HOOKS FOR CYLINDER PRESSES.

See " Caution " and other information on opposite page before ordering.

SIZE.	Outside Dimensions of Blocks.	*Size of Smallest Plate including Bevel.	No. of Side Hooks.	No. of End Hooks.	Imp. Plain Old Style.	Patent New Style.	Patent New Style Iron Blocks.	Proper Number of Blocks to Work a Sheet of Paper.
<b>Folio—</b>								
Imperial . . .	16 × 22½	14¾ × 21¼	4	3	\$7 25	\$8 50	\$21 00	4 blocks to 33 × 46
Super-Royal . . .	13½ × 21½	12¼ × 20¾	4	3	6 80	7 95	19 50	2 blocks to 22 × 28
Royal . . .	12½ × 19½	11¼ × 18¾	4	3	6 40	7 45	18 25	4 blocks to 26 × 40
Medium . . .	11½ × 18½	10¼ × 17¾	4	3	6 10	7 00	17 25	4 blocks to 24 × 38
<b>Quarto—</b>								
Imperial . . .	11 × 16	9¾ × 14¾	4	2	5 30	6 10	15 00	8 blocks to 33 × 46
Super-Royal . . .	10½ × 13½	9¼ × 12¾	3	2	4 50	5 25	13 50	4 blocks to 22 × 28
Royal . . .	9½ × 12½	8¼ × 11¾	3	2	4 25	4 90	12 75	8 blocks to 26 × 40
Medium . . .	9 × 11½	7¾ × 10¾	3	2	4 00	4 60	12 25	8 blocks to 24 × 38
<b>Octavo—</b>								
Imperial . . .	7¾ × 11	6½ × 9¾	3	1	3 30	3 80	10 75	16 blocks to 33 × 46
Super-Royal . . .	6½ × 10½	5¾ × 9¾	3	1	3 15	3 60	10 00	8 blocks to 22 × 28
Royal . . .	6 × 9½	4¾ × 8¾	3	1	3 00	3 40	9 50	16 blocks to 26 × 40
Medium . . .	5½ × 9	4¼ × 7¾	3	1	2 85	3 25	9 00	16 blocks to 24 × 38
Demy . . .	5¼ × 7¾	4 × 6½	3	1	2 70	3 10	8 50	32 blocks to 33 × 46
<b>Duodecimo—</b>								
Broad . . .	5¼ × 6¾	4 × 5½	2	1	2 05	2 45		24 blocks to 23 × 41
<b>16mo—</b>								
Super-Royal . . .	5 × 6½	3¾ × 5½	2	1	1 95	2 30		16 blocks to 22 × 28
Medium . . .	4½ × 6	3¼ × 4¾	2	1	1 85	2 15		32 blocks to 26 × 40
Demy . . .	3¾ × 5¼	2½ × 4	2	1	1 75	2 00		32 blocks to 23 × 33
<b>18mo—</b>								
Medium . . .	3½ × 5¾	2¼ × 4½	2	1	1 75	2 00		18 blocks to 19 × 24
<b>32mo—</b>								
Super-Royal . . .	3 × 5	1¾ × 3¾	2	1	1 65	1 85		32 blocks to 22 × 28

\*A Block will take on a plate ¼-inch smaller each way than its outside dimensions.

RATCHETS FOR STEREOTYPE BLOCKS.

Brass, each . . . . . \$0 50  
Steel, each . . . . . 0 75

EXTRAS FOR STEREOTYPE BLOCKS.

Steel Pinions, each . . . . . \$0 15  
Hooks, each . . . . . 0 10

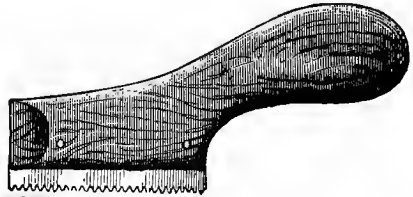

STEREOTYPE SECTIONAL METAL BLOCKS

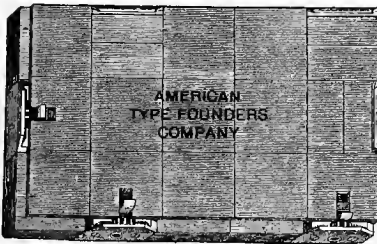

Consist of metal sections, made up of pieces 2×4, 2×8, 4×4, 4×8, and 8×8 ems Pica. Hooks are inserted in the largest sections, which may be arranged on any part of the block, and can be adapted for bed and platen or cylinder presswork. With an assortment of the sections or furniture, the printer may, by a proper combination, prepare a set of blocks to take on a page of any size. To extend size of sectional block, in case there is a shortage of sections, metal furniture not exceeding two ems Pica wide may be used.

Sections with hook, each . . . . . \$1 10  
Brass catches, each . . . . . 0 15  
Sections or furniture, per pound . . . . . 0 25

**WETTER NUMBERING MACHINE.**



No. 1, actual size, Style J.

Adapted to the requirements of every printer. Permits printing and numbering at one impression. Can be used on any make of press. Numbers automatically from the unit to its full numerical capacity. It can be used with or without the character "No." Other characters, such as a star, parenthesis, fist, cipher, or any letter, can be used to either precede or follow the figures. Produces clean, smooth and distinct figures. Styles of figures J and K are most used, and can be furnished promptly, but other and also larger styles can be supplied to order if sufficient time is allowed to cut same.

The 5-wheel style J machine occupies a surface space of  $\frac{3}{8}$  inches in width by  $1\frac{1}{4}$  inches in length.

J 1234567890    K 1234567890

Style J or K, five wheels, numbering up to	99999	\$25 00
Style J or K, six wheels, numbering up to	999999	28 00
Style J or K, seven wheels, numbering up to	9999999	31 00

Unless otherwise ordered, 5-wheel style J machine will be sent.

**WETTER NUMBERING FRAME.**



Specially designed for the purpose of using one or more numbering machines at one time, and operated by two plungers, one on each end of the frame.

Any number of machines can be used in this, and can be set whatever distance apart where the work is directly across the sheet.

This frame makes it possible to operate twelve machines with but one plunger on each end. The plungers touch outside the paper, thereby leaving nothing but the clear, unmarred figures on the surface. Any character or design may precede or follow the numbers, if desired, the same as when used singly and apart from the frame.

This frame makes it possible to do twelve times as much work in almost every variety of numbering as could be done with foot-power machines. The "Wetter" will do a great deal more work simultaneously with the printing.

The price of extra machines to use in the frame is the same as the regular machine. The frames are made to order in various sizes, on which it is impossible to quote price until size is known and quantity required. For all such work special prices will be given.

**SPECIAL WETTER NUMBERING MACHINES.**

*See description and prices on opposite page.*



No. 3.

Made to Order only.

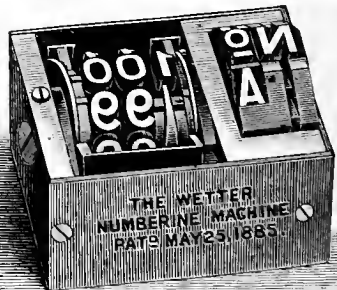

No. 4.

**No. 3. WETTER MACHINE FOR SMALL RAILROAD WORK.**

(See cut page 80.)

Numbers on extreme end, as shown on diagram. Plunger is at foot of machine, and does not strike the printed sheet. Occupies only 5/8-inch space on ticket when locked in form.

**1234567890**

Style of Figures for No. 3 Machine.



- |        |                             |         |
|--------|-----------------------------|---------|
| No. 3. | 5-wheel (figures as above). | \$25 00 |
| No. 3. | 6-wheel                     | 28 00   |
| No. 3. | 7-wheel                     | 31 00   |

**No. 4. WETTER MACHINE FOR NUMBERING CASH SALE SLIPS.**

(See cut page 80.)

Made to number automatically from 100 to 1, or 50 to 1. Object of numbers running backward is to avoid expense of collating sheets after printing. Can be made to number forward. After printing to 100 or 50 they commence again at 1. Plunger wheel can be made with a letter wheel to print A, B, C, D, E, F, G and H, or letter slides may be used in plunger, and any of these letters or the character "No." can be used at will by turning the wheel until the desired letter is on top.

Price, 3-wheel, with letter wheel . . . . . \$25 00

**No. 5. WETTER DUPLEX MACHINE FOR NUMBERING DUPLEX RAILROAD TICKETS.**

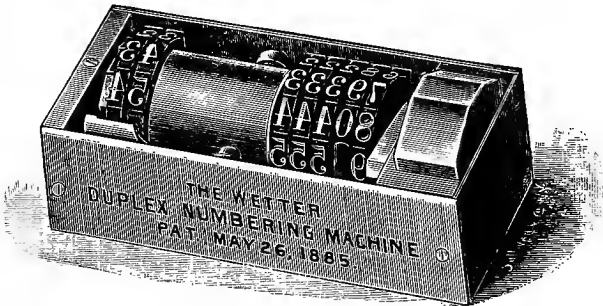

Numbers tickets on both sides and also on stub at one impression. Ticket numbers generally run from 1 to 100 or 0 to 99, and changes consecutively the book number which runs from 1 to 9999 or 1 to 99999. Can be arranged to change once at every one hundred impressions of ticket number, or can be made stationary, so that changes can be made by hand. There are three machines to a set—one for stub and one for each side of the ticket, to be used in same manner as ordinary Wetter Numberer, needing no attachment of any kind.

Set of three machines, net . . . . . \$120 00

**No. 7. WETTER MACHINE FOR NUMBERING BOND COUPONS.**

Numbers with or without serial attachment. 7/8-inch wide, and can be used on narrowest bond coupons. Letter wheel can be placed on end to indicate serial No. A, B, C, D, E, F, G, H, I or J; or the serial letter or character "No." can be placed close to figure, thus—A1.

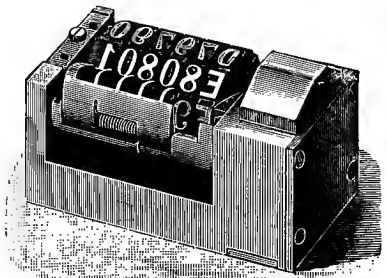

- |                 |         |
|-----------------|---------|
| Price, 5-wheel. | \$25 00 |
| Price, 6-wheel. | 28 00   |
| Price, 7-wheel. | 31 00   |

No. 8. WETTER MACHINE FOR NUMBERING LOTTERY TICKETS.

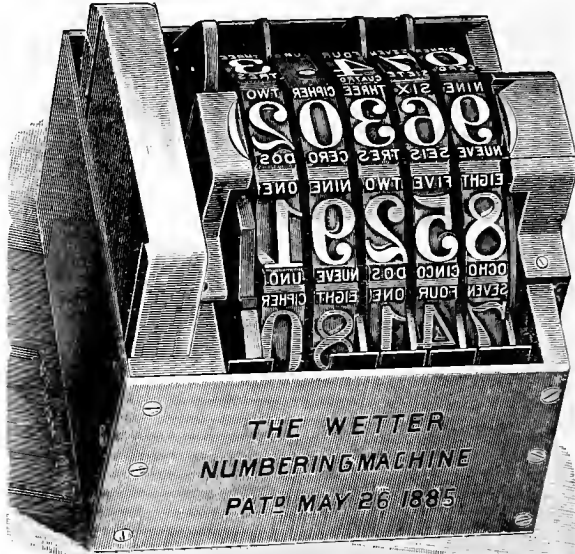

These are considerably more than type high, and the printing-press bed must be sunk or cut out so it will take in a thickness of two inches. We can supply presses for this purpose. Denominations of the figures can be spelled out under and over the figures in any language. Parenthesis marks can be placed at each side of a figure, thus—(1) to (9). At changing to 10 the parenthesis is moved back one step, and may be changed to include all figures until the full number (99999) is printed. Prices on application. Send full details and samples of work required. We show example of the figures used.

SIX SEVEN EIGHT NINE CIPHER  
**(67890)**  
 SEIS SIETE OCHO NUEVE CERO

No. 9. WETTER MACHINE FOR PRINTING NUMBER AND DATE SIMULTANEOUSLY.

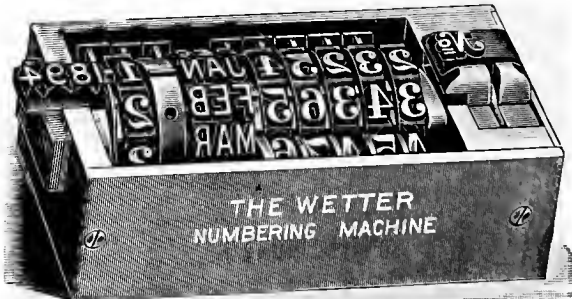

Designed for printing tickets, envelopes, or documents requiring both date and number, such as church envelopes, thus—  
**25098 JAN 23-1896**  
 Works automatically, Machine. Price, 5-wheel, wheels, and year plates, \$38 00

DURANT COUNTER.

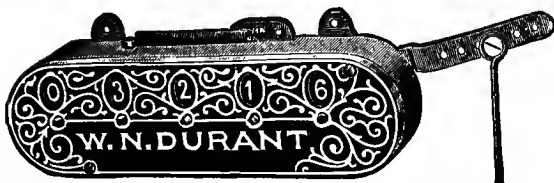

This counter gives perfect satisfaction. It is as reliable as it is strong, durable, and attractive.

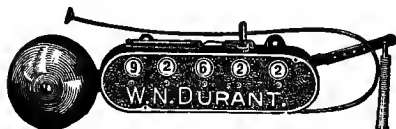

No. 2, with Alarm Gong.

No. 1, 4-dial, counts 10,000 . . .	\$ 8 00
No. 2, 5-dial, counts 100,000 . . .	10 00
No. 3, 6-dial, counts 1,000,000 . . .	12 00
No. 2A, 5-dial, with 4-inch gong, to give alarm at each 100	15 00

DOUBLE DIAL ALARM COUNTER.

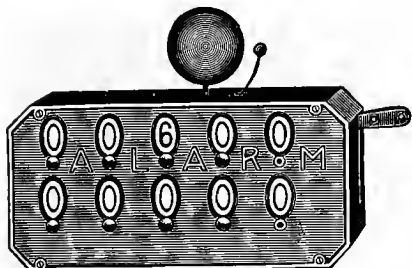

It will show how many yet to run. Perfectly simple in construction. No more springs are used than in an ordinary counter, and all are made of best piano wire. This counter has an iron case, and very legible figures.

This counter is so constructed that the lower dials show the number run like the usual counter. The upper dials are the alarm device, and can be set (instantly without taking from the case, by thumb-screw or key) to any desired number you wish to print, and when that number is printed the bell will ring. To illustrate: Set the alarm on 600, if that is the number you wish to run, with lower dials on ciphers. First revolution of the machine the lower dials will show 1, and the upper dials 599 or one less, and so on until 600 is run, when the upper dials will stand at (000) ciphers and the bell will ring. Any time you look at the counter

No. 1. Double Dial Alarm, 5x8, 1/2-inch figures, registering 100,000 . . .	\$15 00
--	---------

AMERICAN COUNTING MACHINE.

Has no superior for strength, accuracy, reliability. Can be set to zero, or any number, with the fingers with the greatest ease. There are no springs inside this counter, and all movements of the figure-dials are so positive that it is impossible for them to miss registering. The case may be screwed to the wall or on a table, and the lever can be set to any position, and will work from front or back. The figures are cast solid, nickel-plated, and are very legible.

Price . . . . . \$10 00



## GERMAN PRINTING INKS.

These inks are made by one of the most extensive ink manufacturers in the world, and have a world-wide reputation for quality and uniformity. We use them exclusively on our own specimen printing. Inks for special work and to match all colors furnished to order expeditiously.

### SUPERIOR NEWS INKS.

	5 and 10 lb. cans.	28 and 56 lb. cans.	112 lb. barrels.	224 lb. barrels.	450 lb. barrels.
For hand presses, per lb.	\$0 20	\$0 15			
For flat-bed presses,	0 18	0 14	\$0 13	\$0 12	\$0 12
For perfecting presses, "			0 13	0 12	0 12

*N. B.—All inks listed at \$1.50 and over supplied in ¼-lb. tubes if so ordered, but at a lesser discount than is allowed on inks sold in cans.*

### BLACK INKS.

	Per lb.
Book Ink, N	\$0 25
Book Ink, M	0 50
Job Ink, M	0 50
Brilliant Black, L, book	0 75
Brilliant Black, L, job	0 75
Fine Book and Job, K	1 00
Columbian Black, H, for half-tones	1 00
Insurance Policy Black	1 00
Union Black, I, job	1 50
Union Black, I, for half-tones	1 50
Fine Job and Cut, G	2 00
Fine Cut, G, for half-tones	2 00
Gloss Black	2 00
Fine Union Black, F, cut and job	3 00
Fine Union Black, F, for half-tones	3 00
Extra Fine Union Black, E, cut and job	5 00
Extra Fine Union Black, E, for half-tones	5 00
Blue-Black, dark	1 50
Bronze Blue-Black, light	2 50
Bronze Blue-Black, medium	2 00
Fine Green-Black	2 00



### RED INKS.

	Per lb.		Per lb.
Geranium Carmine, 00	\$10 00	Crimson Lake	\$4 00
Geranium Carmine, 1	8 00	Carmine Vermilion	4 00
Geranium Lake, dark	5 00	Brilliant Red, dark	3 00
Geranium Lake, medium	5 00	Brilliant Red, medium, Lake shade	2 00
Geranium Lake, light	5 00	Paris Lake	2 50
Madder Lake	10 00	Chinese Vermilion	2 00
Bronze Carmine	5 00	Hamburg Red	2 50
Leyantine Red	5 00	Brilliant Lake, B	1 50
Claret Color	5 00	Brilliant Lake, G, Lake shade	1 50
Nassau Lake	4 50	Deep Red	1 50
Scarlet Lake	4 00	Brilliant Red, light	1 00
Rose Lake, dark	4 00	Granat Vermilion	1 00
Rose Lake, medium	3 00	Poster Red	0 50
Rose Lake, light	3 00	Poster Orange	0 50
Deep Cherry	4 00		

### BLUE INKS.

Blue Lake, dark	\$5 00	Prussian Blue	\$2 50
Blue Lake, light	5 00	Brussels Blue	2 50
Milori Blue	3 00	Oriental Blue	2 50
Ultramarine, dark	3 00	Marine Blue	2 00
Ultramarine, light	1 50	Peacock Blue	4 00
Imperial Blue	3 00	Deep Blue	1 50
Bronze Blue, No. 1	2 50	Poster Blue	0 50
Bronze Blue, No. 2	2 50		

THE BEST OF EVERYTHING FOR THE PRINTER

GREEN INKS.

	Per lb.		Per lb.
Brilliant Green, light . . . . .	\$5 00	Silk Green, dark . . . . .	\$2 00
Brilliant Green, deep . . . . .	5 00	Silk Green, medium . . . . .	2 00
Victoria Green, dark . . . . .	5 00	Silk Green, light . . . . .	1 50
Victoria Green, light . . . . .	4 00	Olive Green . . . . .	2 00
Viridin Blue . . . . .	5 00	Poster Green, light . . . . .	0 50
Bronze Green . . . . .	4 00	Poster Green, dark . . . . .	0 50
Green Lake . . . . .	3 00		

BROWN INKS.

Brown Lake . . . . .	\$4 00	Terra di Sienna . . . . .	\$2 00
Photographic Brown . . . . .	3 00	Mahogany Brown . . . . .	2 00
Virginia Brown . . . . .	3 00	Ochre . . . . .	1 00
Bismarck Brown . . . . .	3 00	Poster Brown . . . . .	0 50
Velvet Brown . . . . .	2 50		

YELLOW INKS.

Chrome Yellow, deep . . . . .	\$2 00	Persian Yellow . . . . .	\$2 00
Chrome Yellow, light . . . . .	2 00	Sulphur Yellow, dark . . . . .	2 00
Chrome Orange . . . . .	2 00	Yellow, medium . . . . .	1 00
Zinc Yellow . . . . .	2 00	Poster Yellow . . . . .	0 50

PURPLE INKS.

Violet Lake, reddish . . . . .	\$10 00	Brilliant Violet . . . . .	\$4 00
Violet Lake, bluish . . . . .	8 00	Violet No. 1 . . . . .	4 00

GOLD INK.

Pale Gold . . . . .			\$5 00
Rich Gold . . . . .			5 00

WHITE INKS.

Extra Fine Body White (prints white) . . . . .			\$1 50
Fine White, for tints . . . . .			1 00

TINT INKS.

Any shade . . . . .			\$1 00
---------------------	--	--	--------

COPYABLE INKS.

Purple . . . . .	\$5 00	Blue . . . . .	\$5 00
Black . . . . .	5 00	Scarlet . . . . .	5 00
Red . . . . .	5 00	Green . . . . .	5 00

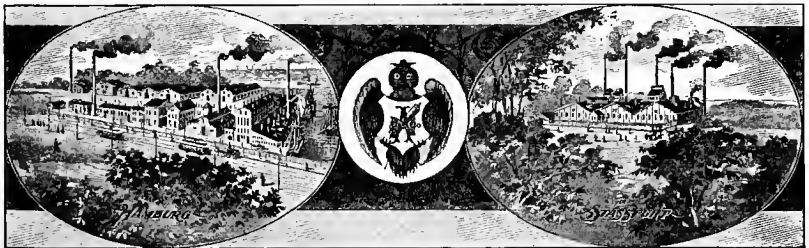

Factories in which Albert Nathan & Co.'s Inks are made. Every ingredient used in high-grade Inks is made in these factories.

**BRONZE SIZE.**

Yellow . . . . .	Per lb.
White, for silver bronzes . . . . .	\$1 50
	1 50

**REDUCING VARNISHES.**

**FOR REDUCING COLORED AND FINE BLACK INKS.**

	Per lb.	Per gal.
Pure Linseed, bleached, A, very soft . . . . .	\$0 50	\$2 25
Pure Linseed, bleached, B, soft . . . . .	0 55	2 25
Pure Linseed, bleached, C, medium . . . . .	0 60	2 50

**ORDINARY, FOR REDUCING BLACK INKS.**

Ordinary . . . . .	\$0 30	\$1 00
--------------------	--------	--------

**GLOSS VARNISHES.**

	Per lb.
Transparent Gloss Varnish, for mixing into inks . . . . .	\$1 50
Body Gloss Varnish, for printing over black and colored inks . . . . .	1 50

**DRYERS.**

Body Dryer, will not reduce consistency or body of inks . . . . .	\$1 50
Fluid Dryer . . . . .	1 50

NOTE—From one to two per cent. of above dryers can be safely used in colored inks, and from three to eight per cent. in black inks.

**BRONZE POWDERS.**

	Per oz.	Per lb.
Extra Fine Brilliant Rich Gold No. 1 . . . . .	\$0 40	\$3 50
Extra Fine Brilliant Pale Gold No. 1 . . . . .	0 45	4 50
Extra Fine Brilliant No. 1, Crimson, Copper, Fire or Green . . . . .	0 45	4 50
Extra Brilliant Rich "Electra" Gold No. 2 . . . . .	0 35	3 00
Extra Brilliant Pale "Electra" Gold No. 2 . . . . .	0 40	4 00
Brilliant Pale Gold No. 3 . . . . .	0 25	2 00
Brilliant No. 3, Crimson, Copper, Fire or Green . . . . .		3 00
Rich or Pale Gold, grade A . . . . .		1 00
Pale Gold, grade B . . . . .		1 25
Silver No. 1 . . . . .	0 50	5 00
Silver No. 2 . . . . .	0 40	3 50
Silver No. 3 . . . . .	0 25	2 50
Aluminum . . . . .		4 00
Patent Bronzes (Light Blue, Dark Blue, Blue Green, Deep Green, Sea Green, Yellow Green, Amaranth and Violet) . . . . .		4 00

**EUREKA TYPE WASH.**

The most effective powder preparation for removing ink from type rollers and plates Does not injure brushes, corrode type, nor hurt the hands. Directions on every package. While its action is gentle, it is quite as effective for cleaning as the most powerful lye. One pound of powder will make eight gallons of washing fluid.

1-pound cans, each . . . . .	\$0 20
5-pound cans, each . . . . .	0 75
10-pound cans, each . . . . .	1 25
50-pound tubs, each . . . . .	5 00





## CHESAPEAKE ECONOMY COMPOUND.

The Effective Ink Reducer for both Lithographic and Letter-press Inks.

**IT IS PURE.**—Chesapeake Economy Compound is absolutely free from mineral petroleum products or acids of any kind, and is perfectly safe. Varnishes may be added, if required.

**IT HELPS INKS.**—Any kind or color of ink mixed with Chesapeake Economy Compound will not dry on forms or rollers, and will not skin when exposed to the air. Upon being mixed with ink, Economy Compound becomes thoroughly identified with it, and with less weight of ink a solid, sharp print is obtained. Inks mixed with Economy Compound will cover 30 per cent. more paper than if used without it.



**IT PREVENTS TROUBLE.**—Coated and surface papers will not pull if printed with ink mixed with Economy Compound, and the use of the Compound tends to prevent off-set and to make inks dry quicker on paper. It is not necessary, as a rule, to wash up rollers at night when inks are mixed with Economy Compound, as the inks will not dry on rollers. Economy Compound keeps lithographic stones in good condition, and inks mixed with it lift well from the stone.

1-pound cans	\$0 75
5-pound cans	3 25
10-pound cans	6 00
25-pound kegs	13 75
50-pound kegs	25 00

### A FEW OPINIONS.

*The Pioneer Press Co., St. Paul, Minn.:* "Ship us 50 pounds Economy Compound, same as furnished heretofore."

*P. F. Pettibone & Co., Chicago:* "We have been using Economy Compound in our press room for some months, and find it a very fine article indeed."

*John A. Lowell & Co., Boston:* "We find Economy Compound most excellent for printing heavy black forms on enameled or coated stock, enabling us to turn out the work quickly and without off-setting."

*Oxford Publishing House, Baltimore, Md.:* "Economy Compound is doing more than is claimed for it. We get full 30 per cent. more from our inks and a much better result in the way of solid color than we did before using it, and the fact that long runs can be left over night ready to start in the morning without washing up is a great saving of both time and ink, especially on hurried work. We have used it for six months and would not be without it."

*G. H. Dunston, Buffalo, N. Y.:* "Economy Compound is the best reducer we have ever used, especially in cases where ink has hardened. This formerly caused us trouble and loss, as it was frequently necessary to throw away such ink; but with this reducer we can put the ink in proper condition for use."

*Matthews-Northrup Co., Buffalo, N. Y.:* "As good a reducer as we have ever used."

*Magee Printing House, Philadelphia:* "It does everything claimed for it. We are very much pleased with it."

### INKOLEUM.



Per bottle, half pound .

A liquid preparation of world-wide fame for reducing and refining printing inks without impairing the color. It makes intractable inks work smoothly on discs, cylinders and rollers, and, mixed with caked inks, makes them useful again. Handy to have in the press room, as it is invaluable in cases of emergency.

\$0 50

## INK AND ROLLER CABINETS.

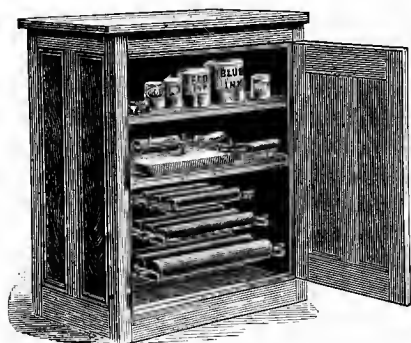

A very necessary article of printing-office furniture. The use of it will result in a saving of ink and rollers, which will speedily pay for the cost of cabinet.

- |   |        |
|---|--------|
| No. 1, with shelf for ink, shelf for brayer and ink slab, and brackets to hold 6 eighth and 6 quarto rollers . . . . .                    | \$6 50 |
| No. 2, with shelf for ink, shelf for brayers and ink slabs, and brackets for 6 each eighth, quarto and half-medium rollers . . . . .      | 9 50   |
| No. 3, with shelf for ink, shelf for brayers and ink slabs, and brackets to hold 12 each eighth, quarto and half-medium rollers . . . . . | 13 00  |

## ADAMSON DISC COVER.

### Makes Copying Inks Work Easy.

Cold iron and copying inks repel each other. To avoid trouble, slip an Adamson Disc Cover over your disc. It is made of special cloth, lined with rubber. Iron dries the ink, deadens it, wastes it. The cloth disc gives good distribution, becomes saturated with ink like a stamp pad, and saves 50 per cent. of ink. When job is done, lift off disc cover. Saves washing time, and all the ink in cover is available the next time you use it. In ordering send the exact size of ink disc.

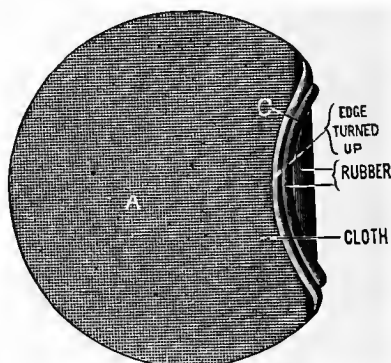

### Directions for Using.

Place the edge or rim of the cover over the lower edge of the disc, and gently draw the cover over the disc, stretching it no more than necessary to just get it over the upper edge. See that the cover lays smoothly on the disc. With a moist (not wet) sponge wipe the upper or cloth face of the cover to remove any dust or foreign particles that may be adhering to it. Then put up ink, and run until distributed. This will take several minutes the first time the disc is used, as the ink should be put on a little at a time until the cover is saturated. After the first run it will only be necessary to put on the cover, and go ahead, as the ink once distributed remains on the cover. Do not wash the disc.

In putting on the cover the first time, be careful that the ratchet pawl, or any retarding spring or brake on the disc, does not catch and tear the edge of the cover. Turn the disc or plate slowly by hand for one full revolution before starting up the press.

For press 7	×11 inches, net	\$1 75
For press 8	×12 inches, net	1 75
For press 9	×13 inches, net	1 75
For press 10	×15 inches, net	2 25
For press 11	×17 inches, net	2 75
For press 12	×18 inches, net	2 75
For press 13	×19 inches, net	2 75
For press 14	×20 inches, net	3 00
For press 14½	×22 inches, net	3 25

Send exact size of disc when ordering.

## HERCULES LIQUID OVERLAY.

A substitute for paper overlays, giving a finer, quicker make-ready, and saving lots of time and tedious work. It is put on thinly with a camel's-hair brush, and the first application should be allowed to dry before putting on another, if the first is not heavy enough. It dries very quickly. If the Liquid Overlay is put on too thickly, the overlay is reduced by scraping it with fine emery cloth.

Each pressman should have an independent supply in a small phial suitable for carrying in the vest pocket.

4-ounce bottle, net . . . . . \$1 25  
8-ounce bottle, net . . . . . 2 00

Full directions with each bottle.

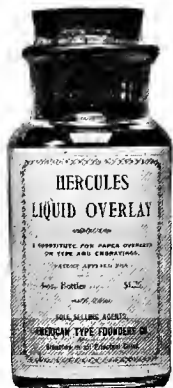

## BURBANK'S EMBOSSING COMPOSITION.

This is an approved and satisfactory liquid chemical preparation for making counter dies for embossing, which, after exposure for a few minutes to light and air, hardens into a stone-like substance, making a perfect counterpart.

Specially adapted for making counter dies for Hand and Power Embossing Presses listed in this Price List.

It is easily applied, according to directions printed on every can, and greatly simplifies and cheapens the process of embossing.

Price, net . . . . . \$0 75



## LAWLOR'S

### "EMBOSSING MADE EASY."

This book explains lucidly and gives directions for several processes of embossing. It is the standard work on the subject.

Price, net . . . . . \$1 00

## "BENTROVATO."

[TRADE MARK.]

### Dispels Electricity from Paper on Printing Presses.

A chemical fluid preparation which, applied in a small quantity to the tympan sheet by means of a sponge, cloth or cotton waste, effectually dispels the electricity generated in cylinder presses—a difficulty which results in serious losses to printers.

In all offices where there is a tendency toward this trouble, a bottle of "Bentrovato" will prove as valuable as the proverbial "stitch in time."

"Bentrovato" is used in a majority of the larger printing offices throughout the United States.

*American Type Founders' Co.:* Please send me at once by American Express one bottle of "Bentrovato." I should not like to be without it, even if it cost \$10 per bottle. Our devil knocked over the first bottle you sent us. I bought it with no faith, simply because I was willing to try anything. Our paper was as if possessed by ten thousand devils. The trouble ended at once and completely with the use of the "Bentrovato."—WALTER B. SHEPPARD, publisher of the *Pan Yan Democrat* (founded in 1818).

Per bottle, net . . . . . \$0 50



**HAND ROLLERS.**

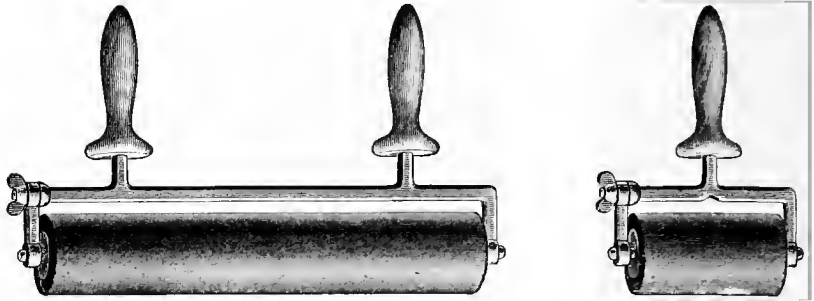

The frames of Nos. 1 to 7 are of wrought iron, the other frames of malleable iron. When complete rollers are ordered, we furnish them with the best roller composition. There is no economy in cheap roller composition.

	Number of Handles.	Frame with Stock.	Extra Stocks, each.	Complete with Com-position.	No.	Number of Handles.	Frame with Stock.	Extra Stocks, each.	Complete with Com-position.
6 in.	1	\$1 25	\$0 40	\$1 75	1,	19 1/2 in.	\$2 75	\$0 95	\$4 25
8 in.	1	1 25	0 40	1 85	2,	22 1/2 in.	3 00	1 00	5 00
10 in.	1	1 50	0 50	2 20	3,	26 1/2 in.	3 50	1 10	5 75
12 in.	1	1 75	0 60	2 55	4,	31 in.	4 00	1 25	6 25
14 in.	2	2 00	0 70	3 00	4 1/2,	36 1/2 in.	4 50	1 40	6 75
16 in.	2	2 25	0 80	3 45	5,	39 1/2 in.	4 65	1 45	7 25
18 in.	2	2 50	0 90	3 90	5 1/2,	41 1/2 in.	4 80	1 50	7 50
19 1/2 in.	2	2 65	0 95	4 15	6,	44 1/2 in.	5 00	1 55	8 00
					7,	48 1/2 in.	5 50	1 70	8 50

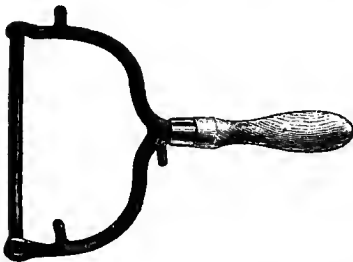

**PROOF ROLLERS.**

Malleable iron frame, wooden core and handle.

	Frame and Core.	Roller Complete.
6-inch	\$1 00	\$1 50
8-inch	1 05	1 60
10-inch	1 10	1 75
12-inch	1 25	2 00

**STEEL ROLLER SUPPORTERS.**

The best bearers yet devised for job presses. They only take up a quarter of an inch of the inside space of a chase, ease the pressure of the rollers on the form, prevent over-inking, equalize the impression, and save the rollers from cutting, as they are 3/8-inch wide on top.

	Per pair.
For 5 x 9 chase . . . . .	\$0 35
For 7 x 11 chase . . . . .	0 40
For 8 x 12 chase . . . . .	0 45
For 10 x 15 chase . . . . .	0 50
For 11 x 17 chase . . . . .	0 60
For 13 x 19 chase . . . . .	0 75
For 14 x 20 chase . . . . .	0 90
For 14 1/2 x 22 chase . . . . .	0 90

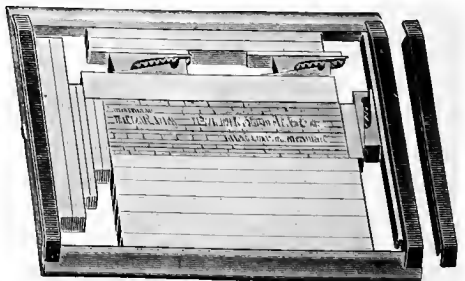

**ELM CITY BRONZING PAD.**



This has become an article of necessity in the press room. Saves time and bronze, and insures clean work.

Large, 2½×6 inches . . . . .	\$2 50
Small, for light work, 2½ inches square . . . . .	1 50

**BRONZING MITTEN.**

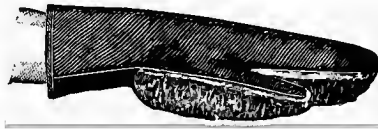

A convenient appliance for bronzing. Made from sheep's wool, with strong cloth back, and is impervious to bronze.

Each . . . . .	\$0 50
----------------	--------

**BRONZE POWDERS.**

*See Specimens in our Ink Specimen Book.*

	Per oz.	Per lb.
Extra Fine Brilliant Rich Gold No. 1 . . . . .	\$0 40	\$3 50
Extra Fine Brilliant Pale Gold No. 1 . . . . .	0 45	4 50
Extra Fine Brilliant No. 1, Crimson, Copper, Fire or Green . . . . .	0 45	4 50
Extra Brilliant Rich "Electra" Gold No. 2 . . . . .	0 35	3 00
Extra Brilliant Pale "Electra" Gold No. 2 . . . . .	0 40	4 00
Brilliant Pale Gold No. 3 . . . . .	0 25	2 00
Brilliant No. 3, Crimson, Copper, Fire or Green . . . . .		3 00
Rich or Pale Gold, grade A . . . . .		1 00
Pale Gold, grade B . . . . .		1 25
Silver No. 1 . . . . .	0 50	5 00
Silver No. 2 . . . . .	0 40	3 50
Silver No. 3 . . . . .	0 25	2 50
Aluminum . . . . .		4 00
Patent Bronzes (Light Blue, Dark Blue, Blue Green, Deep Green, Sea Green, Yellow Green, Amaranth and Violet) . . . . .		4 00

**BRONZE SIZE.**

Yellow . . . . .	\$1 50
White, for silver bronzes . . . . .	1 50

**GOLD INK.**

Pale Gold . . . . .	\$5 00
Rich Gold . . . . .	5 00

**MOVABLE DRYING RACKS.**

The frames of both these racks are of hard wood, bolted together, and mounted on strong casters, so that they can be easily moved when loaded. The shelves of the Chicago Rack are framed all around with hard wood, while those of the New York Rack are framed on ends only.

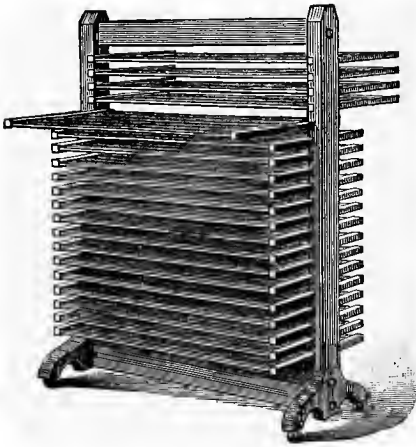

No. 1 New York Drying Rack.



No. 6 Chicago Drying Rack.

**NEW YORK DRYING RACKS.**

- |   |   |
|---|---|
| No. 1, 20 shelves, each 24×36 in. . . \$14 00 | No. 3, 20 shelves, each 28×42 in. . . \$20 00 |
| No. 2, 30 shelves, each 24×36 in. . . 20 00   | No. 4, 30 shelves, each 28×42 in. . . 28 00   |

The No. 1 rack (the cheapest) gives a drying area of one hundred and twenty square feet, while actually using only six square feet of your costly floor space.

**CHICAGO DRYING RACKS.**

- |   |  |
|---|--|
| No. 5, 12 shelves, each 2×2 feet . . \$14 00  | No. 6, 10 shelves, each 2×3 feet . . \$18 00 |
| No. 7, 10 shelves, each 2½×4 feet . . \$23 00 |  |

This rack is the most substantial movable drying rack made. Although it has fewer shelves than a New York, the extra space between the shelves is a distinct advantage, as on small jobs the sheets can be handled without moving the shelf on which they are placed. When not in use the shelves may be put out of the way, as illustrated in cut.

**BEST RACKS FOR LARGE EDITIONS.**

On opposite page we describe a patented rack which has saved large firms thousands of dollars per year by enabling them to utilize their floor space to the utmost extent, making slip-sheeting unnecessary on very many jobs and preventing wastage by handling sheets. The interlocking device and method of inserting the slats into the sides is very plainly illustrated in Figure 2. No large establishment can afford to use wall-racks now that these effective racks, used in connection with trucks, will save their cost every month in the year.

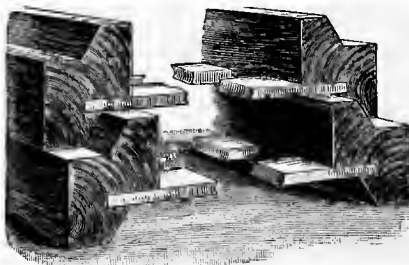

Figure 2. End View of Interlocking Device.

**KÖRNER'S PATENT INTERLOCKING DRYING RACKS.**

(United States Patent, No. 392,735; Canadian Patent, No. 28,739.)

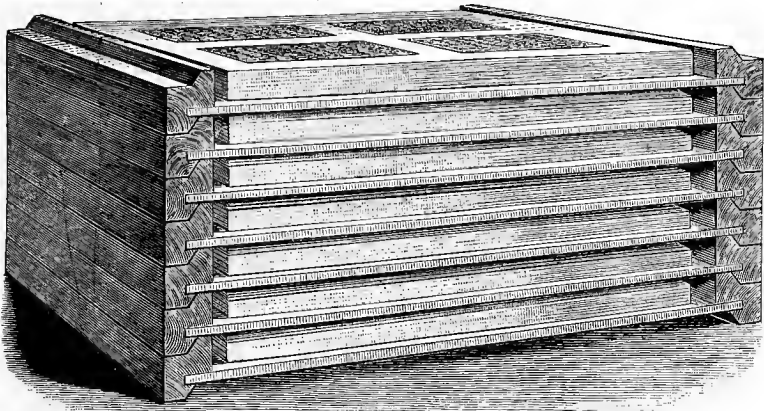

Fig. 2. Interlocking Racks Stacked with Paper, Straight and Rigid.

These racks are for establishments which work on long runs, for color work, and for lithographers. They are used on *Puck* and *Truth*, and the American Lithographing Company has over 25,000 of them in its various establishments in New York City alone.

With these racks sheets are taken direct from the fly of the press, and may be stacked ceiling-high in a perfectly straight and rigid pile, which cannot be knocked over by accident, and with no more weight on the bottom than on the top sheets. This pile is a most effective drying room, occupying only the floor space of one rack, and from the time the sheets are fed into the machine until ready for shipment they need not be handled. The interlocking device, which makes the pile straight and rigid, is shown in Figure 2. Each rack is firmly locked on its neighbor, but each slides with ease on the rack immediately below it. They save handling, all the time of that operation, and the consequent waste of paper through offset, smearing, finger-marks and tearing. In many cases these racks save expensive slip-sheeting. They circumvent electricity by receiving the sheet direct from the fly. They insure evenness of temperature, and thereby assist in getting a perfect register on lithographic work. They save seventy-five per cent. of floor space over any other method of drying sheets, and from one to two per cent. of paper, and a vast amount of time. A further saving of time may be effected by placing the racks as they come from the fly-board on a printer's truck, made specially to take these racks (see next page). A pile of racks can be moved quicker, safer and easier on the truck than a single armful can be moved by hand. The racks have hard-wood sides with wide soft-wood slats, and are very strongly put together.

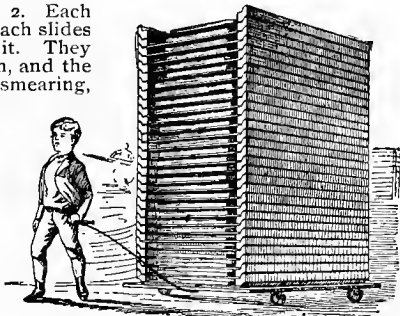

Fig. 1. Körner's Racks on Printer's Truck.

**NET PRICES.—Special Quotations Made on Car-load Lots.**

*These racks are made to order, and sizes will be varied to suit purchasers, at prices approximate to those quoted here:*

38×52 in. inside and under . . .	\$0 65	15 ×21 in. inside and under . . .	\$0 35
32×48 in. inside and under . . .	0 60	13 ×19 in. inside and under . . .	0 30
24×36 in. inside and under . . .	0 50	11 ×17 in. inside and under . . .	0 25
18×25 in. inside and under . . .	0 40	8¾×13 in. inside and under . . .	0 20

**MILLER PERFECT GRIPPER PERFORATOR.**

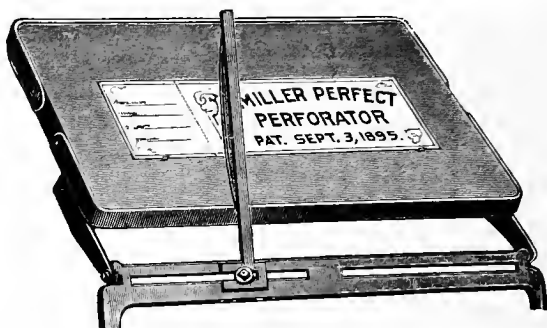

Made of steel, to attach to any platen press. Perforates neatly and cleanly while printing. Does not interfere with impression. There is a half elliptic spring which pushes the perforated sheet off the perforating knife.

For Eighth-Medium Press, net	. . . . .	\$5 00
For Quarter-Medium Press, net .		6 00
For Half-Medium Press, net	. . . . .	7 00

When ordering it is necessary to state name and size of press.

**PRINTERS' TRUCKS.**

**Lay Printed Sheets on Trucks and not on the Floor, and thus Save Cost and Loss in Handling.**

With platform 34 inches wide by 50 inches long, 11 $\frac{3}{4}$  inches high . . . . . \$16 00

*Special prices in quantities. Other sizes at proportionate rates.*

Made of hard wood 1 $\frac{3}{4}$  inches thick, bolted, varnished. Center wheels, 9 $\frac{1}{4}$  inches diameter, 3 inches face. Caster wheels, 4 $\frac{3}{4}$  inches diameter, 1 $\frac{1}{4}$  inches face. Steel axle, 1 $\frac{1}{4}$  inches square, with steel braces 1 $\frac{1}{4}$  x  $\frac{1}{4}$  inches. The T-shaped handle is of  $\frac{3}{8}$ -inch round steel, and is quickly attached to or detached from two eyelets fixed at each end. Weight, 182 pounds; handle weighs 11 $\frac{1}{2}$  pounds.

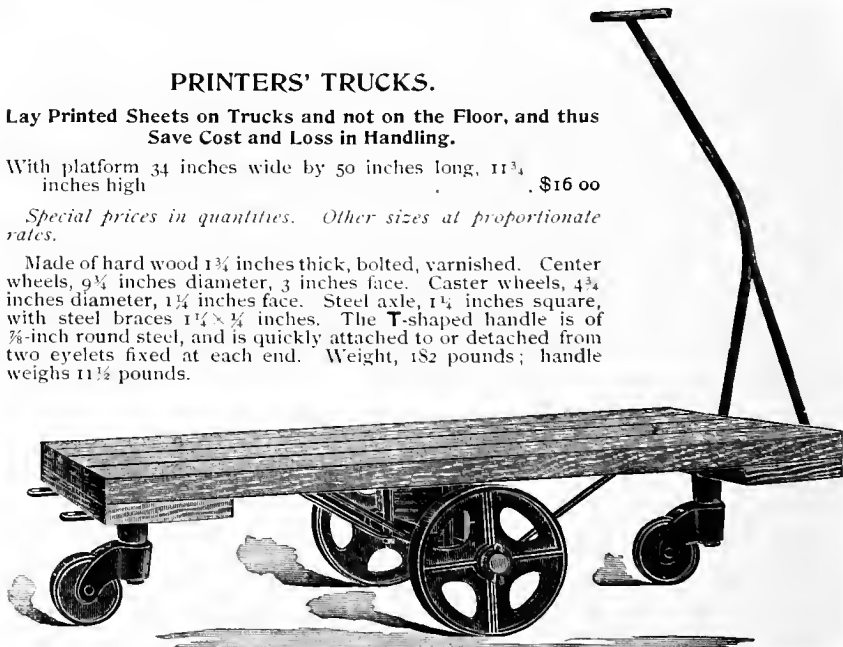

*In 1896 we sold 120 of these trucks on one order to Matthews-Northrup Co., Buffalo, for use in their printing department.*



CHANDLER & PRICE GORDON PRESS.

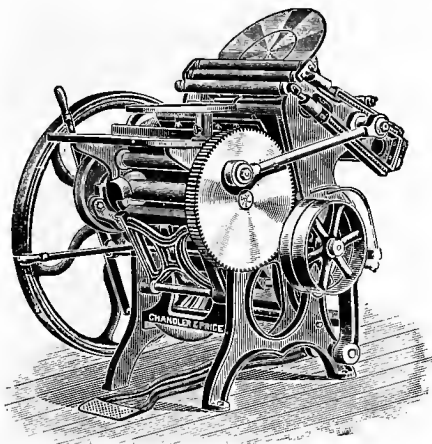

A most popular press, and over 8000 are in use. They are built to withstand both use and abuse. Side arms and shaft are made of forged steel, without seam or weld. Cam rollers are made of hardened tool steel. Impression throw-off is positive and easy to operate. The grippers are depressible, and cannot get under the rollers. Chase clamp is safe and instantaneous.

Eighth Medium,	7	×11 inches inside chase . . . . .	\$150 00
Eighth Medium,	8	×12 inches inside chase . . . . .	165 00
Quarto Medium,	10	×15 inches inside chase . . . . .	250 00
Half Medium,	12	×18 inches inside chase . . . . .	300 00
Large Half Medium,	14	×20 inches inside chase . . . . .	400 00
Half Super-Royal,	14½	×22 inches inside chase . . . . .	450 00
Steam Fixtures, all sizes			15 00
Buckeye Fountain . . . . .			10 00
Chandler & Price Fountain . . . . .			20 00

With each press there are three chases, one brayer, two sets of roller stocks, two wrenches and one roller mould. No charge for boxing and shipping. If desired, will furnish two extra chases instead of mould.

Shipping weights: 7×11, 1000 lbs.; 8×12, 1200 lbs.; 10×15, 1800 lbs.; 12×18, 2500 lbs.; 14×20, 3000 lbs.; 14½×22, 3100 lbs.

*For prices of extra chases, see "Chases."*

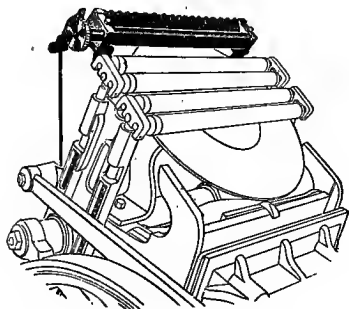

Chandler & Price Fountain.

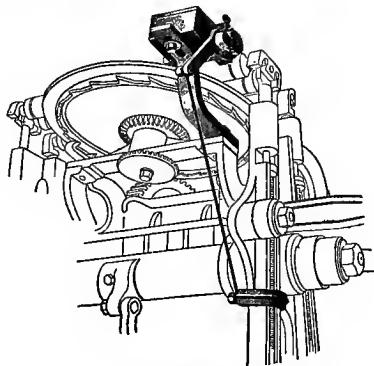

The Buckeye Fountain.

**GALLY UNIVERSAL PRESS.**

*The Gally Universal Press is made in three styles, which are described on next page.*

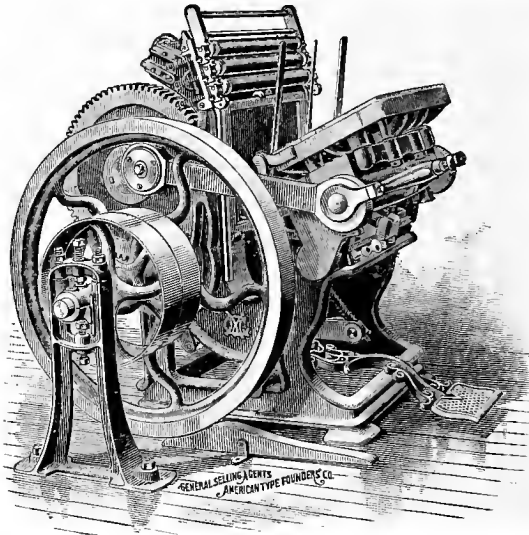

Excels all other types of platen presses because: (1) The bed and frame are cast in one piece, securing rigidity and keeping all shafts in line in spite of irregularities in floor or foundation. (2) The platen moves up squarely against the type form, giving a perfectly square impression. (3) The platen has nine supports, and is extra heavy, and is the only platen capable of sustaining the powerful impression necessary to secure the best results on large forms of cuts. (4) The impression can be thrown off instantly, the throw-off being controlled by a bar directly behind the platen. (5) The impression can be changed instantly all over the platen, varying from the imperceptible to an eighth of an inch. (6) The platen opens out widely, making it easy to feed paper into it. (7) The ink fountain is as efficient as the fountains on the highest grade cylinder presses. It is the most perfect fountain for a platen press ever made. (8) The operations of ink distribution and "inking" the form are distinct, and each performed by a separate set of rollers. In addition to the fountain ductor roller, there are four ink distributors (two of composition, two of iron) which supply two inking cylinders, from which the three form rollers receive a fresh, distributed supply of ink at each impression. On all other types of presses the form rollers have to distribute the crude ink as it leaves the fountain. (9) The form rollers can be held against the inking cylinders for distribution, while getting up color, and need not touch the type form. (10) The ink fountain can be divided by partitions for printing two or more colors at one time. (11) The weight and strength are greater than in any other platen press, as it is designed to do work that cannot be safely attempted on any other type of press.

The Gally Universal is designed for use by the best class of printers. In the hands of competent pressmen the press is the most durable, and will do first-class work in perfect register longer than any other press. We can refer purchasers to presses which have been in constant use for twenty years, doing perfect work to-day, and bidding fair to give the best results for years to come.

The recent application of continuous-motion impression cranks and a new patented platen control have increased the speed on all sizes. Speed requirements vary with the kind of work. These presses will run smoothly at the following maximum speeds: 10×15-inch size, 2600 per hour; 13×19-inch, 1800 per hour; 14×22 inch, 1700 per hour.

PRICES OF GALLY UNIVERSAL PRESSES.

Complete with ink fountain, power fixtures, combination belt-shifter and brake, f. o. b. factory.

		Style One.	Style Two.	Style Three.
Quarto Medium,	10×15 inches inside chase . .	\$350 00		\$450 00
Half Medium,	13×19 inches inside chase . .	450 00	\$500 00	600 00
Half Super-Royal,	14×22 inches inside chase . .	515 00	575 00	650 00

The following small parts are included with each press: Three chases, one roller mould (for which two chases will be substituted, if preferred), six form roller stocks, four distributor roller stocks, two ductor roller stocks, twelve roller wheels (six large, six small), two iron lateral distributors, two feed tables, one small and one large wrench, one socket wrench, one chase latch wrench, and treadle fixtures. If treadle fixtures are not required, two chases will be sent in lieu of them.

Power fixtures include fixtures on the press only.

Boxing for export: Quarto Medium, \$7 00; Half Medium, \$10 00; Half Super-Royal, \$15 00, net.

DESCRIPTION OF THE THREE STYLES.

STYLE ONE.

This is the style described above.

STYLE TWO.

Differs from Style One in having a double impression latch and a steel segment in the gear at the point that takes the strain of the impression.

STYLE THREE.

This style is recommended to those who want the best press procurable for executing the finest class of cut, solid block and color printing, cold embossing and stamping. This style is also made in combinations and for special work, as described hereafter.

The style No. 3 Universal Press differs from Style No. 1 in the following particulars:

The driving shaft is extended to carry an extra outside floor support. The pulleys are intended to carry a 2¼-inch belt on Quarto Medium and a 3¼-inch belt on larger sizes. The fly-wheel on Quarto Medium weighs two hundred pounds, and on the Half Medium and Half Super-Royal three hundred pounds each. The large gear-wheel has a section of best quality of steel welded into its periphery, in which are formed the impression teeth, *i. e.*, those teeth which are in engagement with the driving pinion and transmit the momentum of the fly-wheel to the cranks during the time of the "nip." The main shaft is of steel, with solid reamed bearing through the bed. The crank-pins are crucible steel, hardened and finely finished. The connecting rods are of forged machinery steel, very heavy, and bushed with phosphor-bronze where bearing on crank-pins. The bridge and platen are solid to each other—no pressure whatever being sustained by screws. Has double impression latch.

COMBINATIONS OF STYLE THREE FOR SPECIAL WORK.

COMBINATION B.

For letter-press printing and (in addition to all work that can be done on regular Style Three Press, listed above) book-cover inlaying, and cutting and creasing. This combination is fitted with a movable ½-inch steel platen plate and a movable ½-inch brass platen plate, the latter for use in cutting and creasing.

Quarto Medium,	10×15 inches inside chase, complete . .	\$450 00
Half Medium,	13×19 inches inside chase, complete . .	625 00
Half Super-Royal,	14×22 inches inside chase, complete . .	676 00

COMBINATION C.

For letter-press printing, hot embossing, and printing on wood not exceeding one inch in thickness (in addition to all work that can be done on Combination B). This combination is fitted with a steam blank (¾-inch thick) with pipe connections, a movable ½-inch steel die plate on steam blank, a movable ½-inch steel platen plate, a movable ½-inch brass platen plate, a cast-iron platen blank, ¾-inch thick, with tympan clamps attached, and a cast-iron platen plate ½-inch thick.

In ordering Combination C, it is necessary to state the average thickness of embossing dies. It is recommended that dies should not be more than ¼-inch thick.

* Half Medium,	13×19 inches inside chase, complete . .	\$722 00
* Half Super-Royal,	14×22 inches inside chase, complete . .	784 00

Price List continued on next page.

**PRICES OF GALLY UNIVERSAL PRESSES.—Continued.**

**COMBINATION D.**

For letter-press printing, printing on wood (not exceeding one inch in thickness) and cold embossing. This combination is fitted with a 3/8-inch movable platen blank and a 3/8-inch movable steel platen plate. Cutting and creasing can be done on this combination by adding a 3/8-inch brass platen plate, list prices \$10.00 to \$13.00 each.

* Quarto Medium,	10×15 inches inside chase, complete .	\$474 00
* Half Medium,	13×19 inches inside chase, complete .	629 00
* Half Super-Royal,	14×22 inches inside chase, complete .	679 00

**\* IMPORTANT NOTICE.**

The specifications given for preceding combinations may be varied to accommodate the requirements of purchasers. In ordering variations from above specifications be careful to state exact thickness of plates and blanks required, and fully describe the work to be done on the press ordered. Special combinations for other purposes made to order at prices proportionate to those charged for above combinations.

**PRICE LIST OF ATTACHMENTS FOR GALLY UNIVERSAL PRESS.**

	10×15 Press.	13×19 Press.	14×22 Press.
Ink fountain . . . . .	\$20 00	\$25 00	\$25 00
Fountain partitions, each . . .	4 00	4 00	4 00
Power fixtures on press only	10 00	10 00	10 00
Overhead fixtures, complete	25 00	30 00	30 00
Cast-iron chases. . . . .	2 00	2 25	2 75
Wrought-iron chases	5 50	6 50	7 25
Roller stocks . . . . .	0 60	0 65	0 75

**SPECIAL FEATURES OF THE GALLY UNIVERSAL PRESS.**

**TWO TYPES OF PLATEN PRESSES.**

The Universal Press, when invented and patented in 1869-70, differed radically both in its fundamental principles and labor-saving appliances from any other platen press in use at that time. Since then platen presses everywhere are divided into two recognized types or classes, each taking the name of the original inventor: the "Gordon" type, with its hinged or "clam-shell" movement of bed and platen, as imitated with slight variations under a great variety of names, all distributing ink by means of a disc, and the "Gally Universal" type, with its fixed bed, sliding platen, square impact of impression on the form, solid frame and cylindrical ink distribution.

**IMPRESSION.**

The ideal impression is given by a Washington Hand Press, and the impression given by the Gally Universal is similar, and is perfect in practice and in theory. No other type of platen press can give a perfectly square impression.

The platen is massive, and is secured to the platen bridge by four controlling screws which pass through the bridge, and is supported at the corners and in the centre by five adjustable screw supports, giving nine supports in all. Thus the utmost strength and an unyielding impression is obtained.

The platen movement in relation to the bed is illustrated in Figs. 2 and 3 (sectional drawings from the inside).

Fig. 2 shows the platen open at the feeding position, supported by the rockers (R) on the slideways (s). The movement is controlled by the draw-bars, which connect with a steel shaft (A) passing through the platen bridge. As the draw-bars pull the platen toward the bed it rocks forward until the flattened toes (e) of the rockers rest on the slideways (s), as shown in Fig. 3.

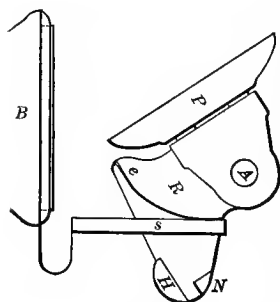

Fig. 2.

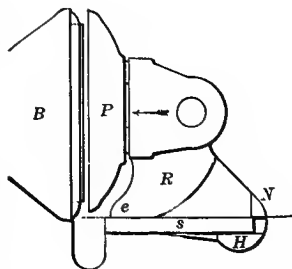

Fig. 3.

The platen is now half an inch from the type form, and exactly parallel to it, and the locking lugs (*N* and *H*) have engaged the slideways at top and bottom, preventing the platen from tipping. Thus secured, the platen slides squarely to the type form, taking a direct face impression. The platen then slides back and rocks to the feeding position again. The curve of the rockers (*R*) are struck from a point at the center of gravity of the whole moving piece, so that the movement is accomplished with a trifling expenditure of effort.

**DISTRIBUTION OF INK.**

The superiority of the Gally Universal Press is in no point more apparent than in the distribution and application of ink to the form. In Fig. 10 is shown the Gally Universal system of ink distribution. *C* is the main distributing cylinder, and *S* is the secondary distributing cylinder. The composition distributing rollers (*e* and *e'*) revolve on the distributing cylinders, and on top of the distributors are two metallic rollers (*v* and *v'*) with a steady lateral movement in opposite directions, constantly crossing and recrossing the lines of distribution. The ink is supplied from the fountain (*F*, Fig. 10) to the distributing cylinder (*C*), once at each impression, by the ductor roller (*H*), in an evenly spread line, immediately after the form rollers have left the cylinders to ink the form; and before the rollers have completed the rolling of the form and returned to the cylinders the applied ink is thoroughly distributed by the distributors (*e e'*), so that no undistributed ink can ever reach the form rollers or be applied to the form.

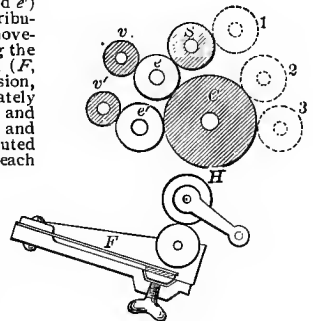

Fig. 10.

The distribution of ink is constant while the press is in motion, whether the form rollers (1, 2, 3) are in contact with cylinder or on the form. The cylinders, rollers and lateral distributors, as shown in Fig. 10, are made of different diameters on uneven measurements, so that their lines of contact are not repeated while revolving.

On presses with disc distribution the form rollers must distribute their own ink and convey it to the form, while on the Gally Universal these two functions are performed by two distinct sets of rollers. In the former case the work is necessarily imperfect; in the latter, both processes give perfect results.

**INK FOUNTAIN.**

The Gally Universal ink fountain is as complete as the ink fountain of any first-class cylinder press. Every part of it is under positive control. The movement of the fountain cylinder (*R*, Fig. 19) is regulated by a ratchet lever. The ink is carried from the cylinder (*R*) to the distributing cylinder *C*, Fig. 10, by a composition ductor roller. In nearly all ink fountains the regulating screws press directly against the steel blade, and in setting for a fine feed have a tendency to bind the fountain cylinder.

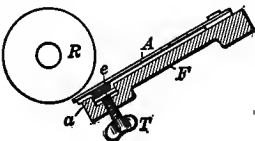

Fig. 19.

In the Universal ink fountain (Fig. 19) *A* is a steel blade, *e* is rubber packing, and *a* is a very thin strip of steel against which the screws (*T*) are set. The rubber (*e*) furnishes an elasticity which prevents the blade from binding, while giving a perfect cut off. With this safeguard a press boy may be trusted to regulate the fountain. The fountain may be removed easily from the press to be cleansed, and is made interchangeable so that an extra fountain for colors may be put on in a few moments.

**ADJUSTMENT OF IMPRESSION AND THROW-OFF.**

The Gally Universal Press was the first to have a quick, easy method of adjusting the impression, and the Gally invention is still unexcelled. The theory of modern fine printing calls for a minimum of tympan packing, and to get this a fine adjustment of the platen impression is necessary. The labor means of the set screws make that practically instantaneous, and al-  
impression by the same device, of the pressman. The impression by means of the adjuster slide (*L*),

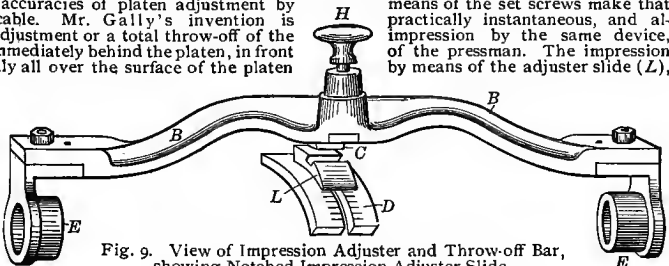
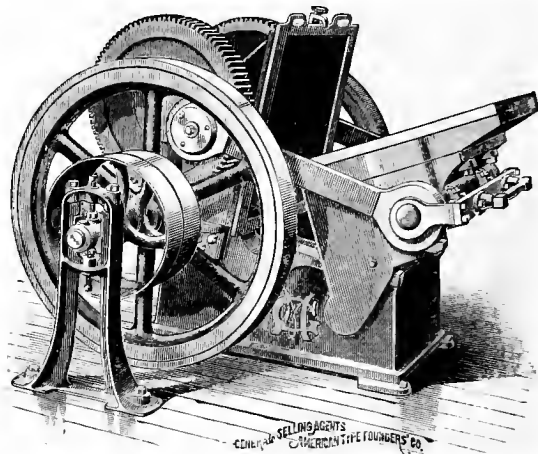

Fig. 9. View of Impression Adjuster and Throw-off Bar, showing Notched Impression Adjuster Slide.

which is located immediately behind the platen, in front is regulated equally all over the surface of the platen which can be moved up or down, increasing or decreasing impression from a tissue paper's thickness to 1/4 of an inch. This slide is notched, and the latch (*C*), which is the lower end of the throw-off handle (*H*), engages in this notch. When it is desired to throw off impression, the handle (*H*) is pulled, the latch (*C*) is disengaged, and the adjuster bar (*BB*) drops down, carrying the platen back and preventing it from taking an impression.

GALLY UNIVERSAL EMBOSSEING PRESS.



These are the largest embossing presses made, and combine strength, power, speed and facility for handling work easily in a degree unequaled by any other press. They are designed for extra heavy hot or cold process embossing, and book-cover stamping ("smashing"). The mechanical principles employed to give impression, power, and to throw-off impression, are the same as described on pages 96 and 97. Nothing better demonstrates the correctness of the mechanical principles on which Gally Universal Presses are built than their applicability to all degrees of power and strain. Every other type of platen press has its limitations—a point where it gets unwieldy and inefficient.

PRICES OF PRESS ONLY.

No. 1. 21¼ × 22-inch bed-plate	\$800 00
No. 2. 24 × 26-inch bed-plate	900 00

PRICES OF EXTRA ATTACHMENTS.

Steam blank, complete, with pipe connections, for No. 1 embosser, with steel die plate	\$105 00
Steam blank, complete, with pipe connections, for No. 2 embosser, with steel die plate	118 00
Steel platen plate for No. 1 embosser	19 50
Steel platen plate for No. 2 embosser	26 00
Cast-iron platen blank for No. 1 embosser	19 50
Cast-iron platen blank for No. 2 embosser	26 00

Each press is complete with power fixtures on press.

Each press is furnished with three chases (or one cast-iron bed blank in lieu of chases, at option of purchaser), two feed tables, one wrench, one belt-shifter and one brake.

Gross weight, boxed, of embossing presses are: No. 1, 3400 pounds; No. 2, 4300 pounds.

Boxing for export: No. 1, \$10 00; No. 2, \$15 00, net.

Prices are f. o. b. factory.

## GALLY UNIVERSAL PAPER-BOX CUTTING AND CREASING PRESS.

(See "Paper Box Making" at foot of this page.)

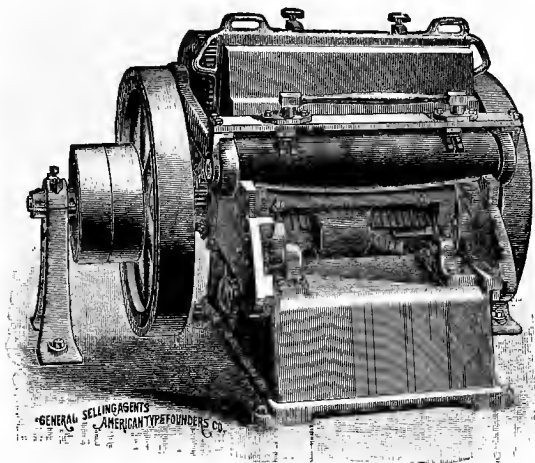

The most satisfactory presses for cutting and creasing paper boxes. Immensely strong, easy to operate, with speed limited only by the capacity of feeder. They will not stall on the heaviest impression. They are built on the same general lines as the Gally Universal Embossing Presses, and have extra steel-gibbed locks on under edge of the platen to prevent deflection of the platen under unequal strain. The platen, which has a throw-off, is set to height of type unless otherwise ordered. Both sizes are double geared.

### PRICES.

With Brass Platen Plate and Power Fixtures on Press.

No. 1.	20 × 30 inches inside chase	\$700 00
No. 2.	23¼ × 31 inches inside chase	900 00

Prices are f. o. b. factory.

Each press is furnished with a ¼-inch brass platen plate, three chases, two feed tables, one wrench, one belt-shifter and one brake.

Boxing for export: No. 1, \$15 00; No. 2, \$20 00, net.

### FOLDING PAPER BOX MAKING.

The process of making folding paper boxes is simple. The stock used is manilla board, made specially for the purpose. A cutting and creasing press is the same as an ordinary printing press, except that it is larger, has to be stronger, and does not require an inking apparatus. The shape of a box having been decided on, a form is set up with steel cutting and brass creasing rules—the former to cut out waste margins and to make slits, and the latter to crease or score the lines on which the stock in the box must bend when set up for use. It is usual to cut and crease as many boxes at one time as can be cut out from a full-sized sheet. The box leaves the press flat. It is then folded once and glued on one edge, and delivered flat. Any printing required is done before cutting and creasing. Any good compositor will understand the process after reading above explanation and examining a folded paper box. The glueing is done by a machine of moderate cost.

## HARRIS AUTOMATIC ENVELOPE AND CARD PRESS.

Fastest Job Press. Speed from 5000 to 12,000 per Hour.

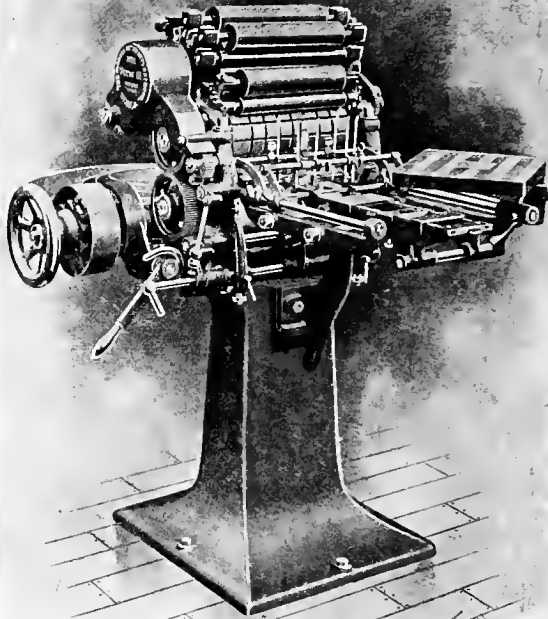

The Harris Automatic is a self-feeding and self-delivering press of recent introduction but well-established reputation. It prints cards and envelopes in one or more colors in first-class style, and will supersede all other presses on work within its capacity in offices where envelopes, cards, or tags, are printed in large quantities in runs of 3000 at a time and upward. It registers closely. It has an automatic throw-off, which causes it to cease taking impressions whenever the grippers fail to grasp the sheet, thus effectively preventing waste of stock as well as offsets. The printing is done from curved stereo. or electro. plates. Making ready is convenient and easy. It is possible to make-ready and run off 5000 envelopes in forty minutes. Distribution is abundant and effective. There is an adjustable ink fountain. The capacity is from the smallest envelope corrier to plates not exceeding 11×13 inches. Prices, terms, circulars, etc., sent on application.

### SELECTED FROM LETTERS RECEIVED FROM USERS.

*James Kempster Printing Co., N. Y.:* "Capable of running over 50,000 impressions a day with little or no spoilage."

*Public Printer, Washington, D. C.:* "The Government Printing Office met an extraordinary demand during the last Presidential campaign, to the extent of printing 60,000,000 (sixty million) envelopes, which would not have been met, for lack of press facilities, had we not fortunately discovered the Harris Automatic Press, which reduced the cost of envelope printing from 35 cents to 11 cents per thousand. We use another Harris press in our job room, and find it convenient for *small runs*, which work we did not anticipate doing on it at time of purchase."



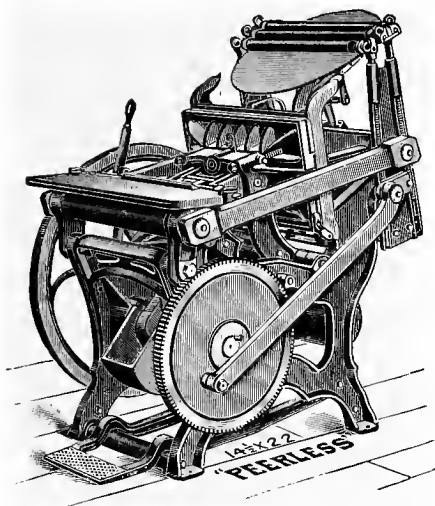

### PEERLESS PRESS.

Of well-established reputation, smooth running, noiseless, easy to make-ready on, easy to feed, easy to run by treadle, with an effective throw-off, well built, exceptionally strong, and with a powerful toggle movement. The throw-off is positive and easy, and convenient to handle. The platen is sustained in the center by the toggle, and is strongest where platens are generally weakest, enabling the Peerless to do embossing and paper-box cutting and creasing, which taxes a press very severely. It is a fast press.

Eighth Medium . . . . .	8 × 12 inches inside chase . . . . .	\$225 00
Large Eighth Medium . . . . .	9 × 13 inches inside chase . . . . .	250 00
Quarto Medium . . . . .	10 × 15 inches inside chase . . . . .	300 00
Large Quarto Medium . . . . .	11 × 17 inches inside chase . . . . .	350 00
Half Medium . . . . .	14 × 20 inches inside chase . . . . .	450 00
Half Super-Royal . . . . .	14½ × 22 inches inside chase . . . . .	500 00
Pony Ink Fountain, all sizes . . . . .		10 00
Hinged Well Ink Fountain, all sizes . . . . .		25 00
Power Fixtures on Press, all sizes . . . . .		15 00

Three chases, six roller stocks, one roller mould, one impression wrench, one brayer, two sets roller trucks, are furnished with each press.

Extra chases cost: For 8×12 press, \$1 50; for 9×13, \$1 50; for 10×15, \$2 00; for 11×17, \$2 00; for 14×20, \$2 75; for 14½×22, \$3 00.

### NEW STYLE FRANKLIN GORDON.

The latest invention of Mr. George P. Gordon, inventor of the popular Old Style Gordon.

8×12 inches inside chase . . . . .	\$225 00
9×13 inches inside chase . . . . .	250 00
10×15 inches inside chase . . . . .	300 00
11×17 inches inside chase . . . . .	350 00
13×19 inches inside chase . . . . .	400 00
Ink fountains, for all sizes . . . . .	25 00
Steam fixtures, for all sizes . . . . .	15 00

One roller mould, six roller stocks, three chases, one impression wrench, one gripper wrench, and one hand-roller are included with each press.

The shipping weights when closely boxed are: 8×12 press, 1100 lbs.; 9×13 press, 1150 lbs.; 10×15 press, 1600 lbs.; 11×17 press, 1700 lbs.; 13×19 press, 2100 lbs.

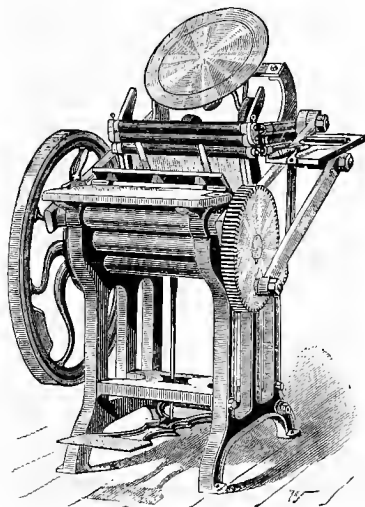

## THE GOLDING JOBBER.

This press can be bought with or without a number of attachments, such as an automatic brayer fountain, a duplex distributor (which is placed below the bed of the press and furnishes a fresh supply of ink to the form rollers after they have passed downward over the form), a chromatic attachment, and a counter for registering the number of actual impressions, the prices for which are given separately below.

### PRICES OF PRESS ONLY.

No. 6, 8×12 inches inside chase	\$200 00
No. 7, 10×15 inches inside chase	275 00
No. 8, 12×18 inches inside chase	350 00
No. 9, 15×21 inches inside chase	450 00

### PRICES OF PRESS, COMPLETE

With Automatic Brayer Fountain, Duplex Distributer and Power Fixtures.

No. 6, 8×12 inches inside chase	\$245 00
No. 7, 10×15 inches inside chase	335 00
No. 8, 12×18 inches inside chase	420 00
No. 9, 15×21 inches inside chase	520 00

The prices of all Golding Jobbers for letterpress printing include three machine rollers complete, extra set of roller cores, extra set of roller wheels, two chases, ink plate, hand roller, wrench, treadle and brake.



Shows style of Nos. 6, 7 and 8 Golding Jobbers.

### PRICES OF ATTACHMENTS AND EXTRAS.

When not ordered complete, any of the attachments or extras wanted will be charged at the following prices:

	No. 6	No. 7	No. 8	No. 9
Fountain and automatic brayer	\$25 00	\$35 00	\$40 00	\$50 00
Duplex distributor	12 00	16 00	20 00	24 00
Chases	1 25	1 50	1 75	2 25
Counter made to attach to press (counts to 10,000)	10 00	10 00	10 00	10 00
Pearl ink fountain	9 00	9 00	9 00	9 00
Power fixtures	14 00	15 00	16 00	17 00
Boxing	4 00	5 00	6 00	8 00

## GOLDING ART JOBBER.

This press is built on the same general lines as the Nos. 6, 7 and 8, illustrated above, but is heavier and stronger; has gear-wheel inside the frame; has impression adjustment at back of bed instead of at back of platen; has four form rollers and a duplex distributor (the latter placed immediately under bed, so that ink on rollers is re-distributed before the rollers return over the type form); throw-off by means of an eccentric shaft instead of by wedges; and the automatic brayer fountain covers the full length of the disc instead of half of it. This press is also supplied with the half-length automatic brayer fountain, if desired.

No. 18 Golding Art Jobber, 12×18 inches, complete, with power fixtures	\$500 00
No. 18 Golding Art Jobber, 12×18 inches, with half-length automatic brayer fountain and power fixtures	470 00

CHROMATIC ATTACHMENT for No. 7 Jobber, including full-length fountain, \$65.00 additional to price of complete press; for No. 18 Art Jobber, having full-length fountain, \$50.00 extra.

PEARL PASSES

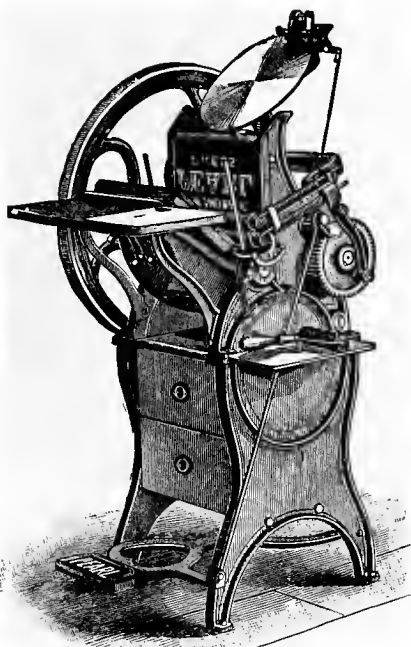

Pearl Presses, Nos. 1, 3 and 5.

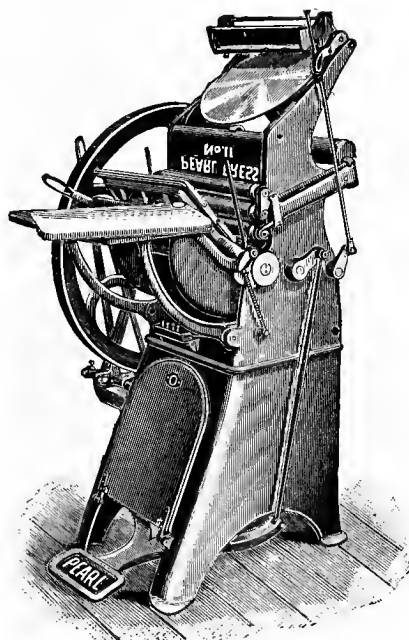

Pearl Presses, Nos. 11 and 14.

Light running presses, without side-arms, very rapid, easy to feed, and handy to make-ready on. They are practically noiseless, easy to keep in repair, and specially desirable in offices that have no power. The No. 1 has three drawers and the No. 3 two drawers in their stands.

PRICES OF PEARL PASSES.

Nos. 1, 3 and 5 have no throw-off. Nos. 1, 3 and 5 have two rollers; Nos. 11 and 14 have three rollers.

No. 1, 5× 8 inches inside chase	\$ 70 00
No. 3, 7×11 inches inside chase	110 00
No. 5, 9×14 inches inside chase	165 00
No. 11, 7×11 inches inside chase	135 00
No. 14, 9×14 inches inside chase	200 00

The prices of Nos. 11 and 14 include full-length fountain and throw-off.

POWER FIXTURES.

For No. 1 . . . . .	\$ 8 00
For No. 3 . . . . .	9 00
For Nos. 5 and 11 . . . . .	12 00
For No. 14 . . . . .	14 00

PEARL INK FOUNTAINS.

For Nos. 1, 3 and 5 Presses, each . . . . .	\$9 00
---	--------

A full length fountain is included in the price with Nos. 11 and 14 Pearl Presses.

**PILOT  
HAND LEVER  
PRESS.**

6½ × 10 inches inside chase . . . \$35 00  
Ink fountain . . . 10 00

One chase, one set of covered rollers, and one wrench supplied with each press.

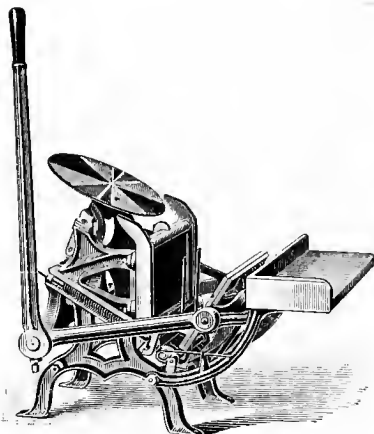

Pilot Press.

**OFFICIAL  
HAND LEVER  
PRESSES.**

No. 3, 5 × 7½ inches  
inside chase . . . \$25 00  
No. 4, 6 × 9 inches  
inside chase . . . 35 00  
No. 6, 8¼ × 12½ ins.  
inside chase . . . 60 00

One chase, one set of covered rollers, and one wrench supplied with each press.

**SECOND-HAND  
PRESSES.**

As a rule, second-hand presses of all makes and sizes can be supplied. Special lists of these are issued at short intervals. Those in want of second-hand machinery are invited to correspond with us. Time will be saved if correspondents will state exactly what they require.

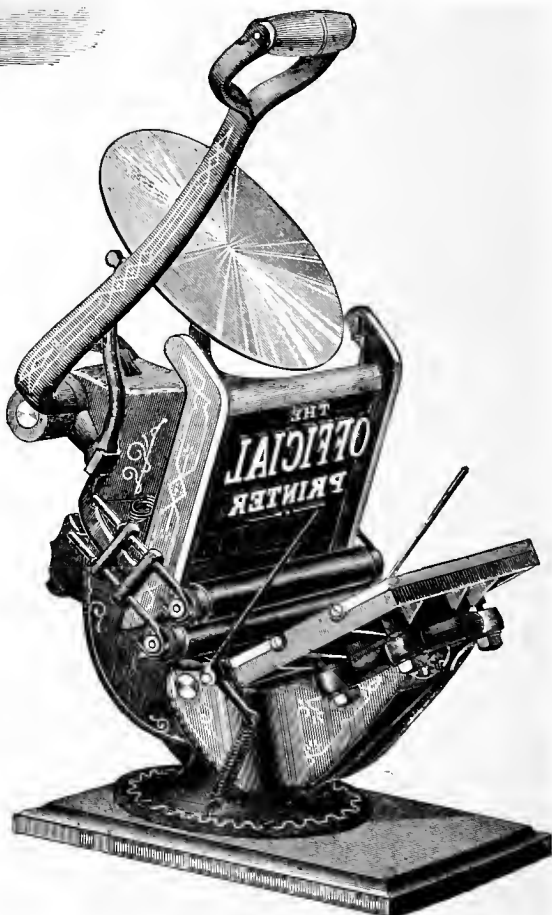

WASHINGTON  
HAND  
PRESS.

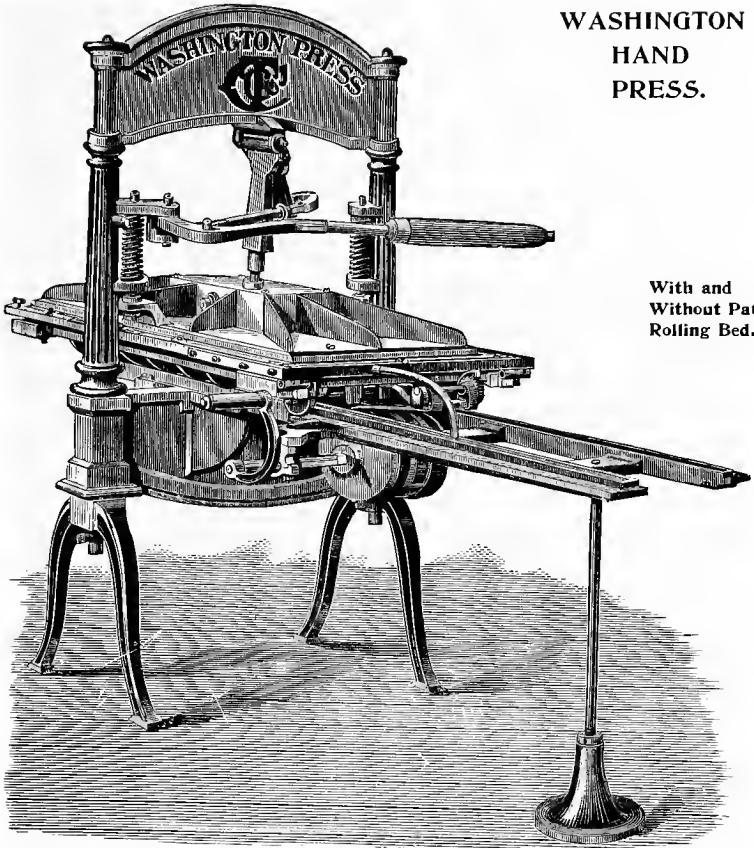

With and  
Without Patent  
Rolling Bed.

Washington Hand Press with Patent Rolling Bed, built solely by American Type Founders Co.

Platen.	Bed.		
14×18 inches . . .	17 ×21 inches		\$150 00
16×21 inches . . .	20 ×25 inches		175 00
20×25 inches . . .	24 ×29 inches		200 00
23×31 inches . . .	25¼ ×34¾ inches, for 6-column folio . . . . .		200 00
23×35 inches . . .	26½ ×39 inches, for 7-column folio . . . . .		225 00
25×39 inches . . .	28½ ×42 inches, for 8-column folio or 5-column quarto . . . . .		250 00
27×43 inches . . .	31½ ×47½ inches, for 9-column folio . . . . .		275 00

**WITH PATENT ROLLING BED.**

The Patent Rolling Bed runs on rollers instead of sliding, and thus much exertion is spared the pressman, and the work is done quicker.

Platen.	Bed.		
23×35 inches . . .	26½ ×39½ inches, for 7-column folio . . . . .		\$250 00
25×39 inches . . .	28½ ×43½ inches, for 8-column folio or 5-column quarto . . . . .		275 00
27×43 inches . . .	31½ ×47½ inches, for 9-column folio . . . . .		300 00
29×43 inches . . .	33 ×48 inches, for 6-column quarto . . . . .		325 00

Above prices include two pairs of points, one wrench, one sheep'sfoot, pair of bearers, and one extra frisket.

As a rule we can supply second-hand Washington Hand Presses of all sizes on demand.

## IDEAL HAND CYLINDER PRESS.

The type form on this press is stationary. The cylinder is moved over the tympan by link belts running over sprocket wheels at each end of the press, and it prints a sheet at each forward or backward movement. The cylinder is made of steel, and is held firmly to the tracks by truck-wheels which run in a groove on the under side of the tracks. The boxes which hold the cylinder at each end, and in which it revolves, are connected by a stretcher rod running above the cylinder, which prevents side friction. The impression is regulated by four screws—two on each side—which raise or depress the bearers on which the cylinder runs. An effective inking apparatus is supplied, but is extra. A number of Ideal Presses are in use, and intending purchasers may gather how satisfactory they are to the users by reading the following extracts from a great many commendatory letters received:

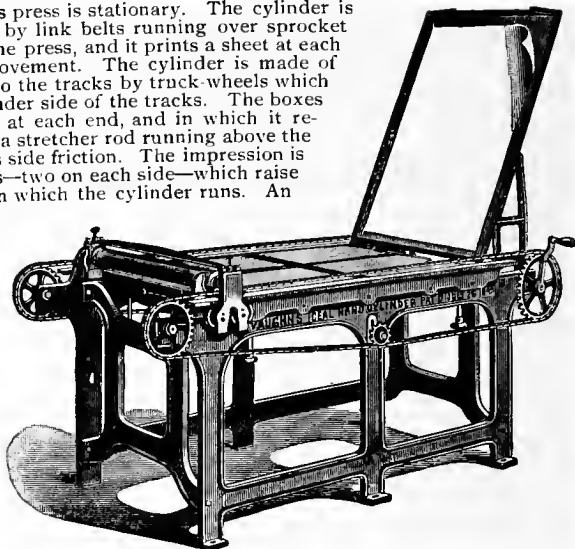

“ My wife ran off 300 an hour on it the first day it was put up.” \*\*\* “ With it our inexperienced pressman has made the following speed: 750 impressions in 75 minutes; 475 in one hour; 100 in 11 minutes. We run a regular lick of 100 every 15 minutes, or 400 per hour.” \*\*\* “ We can run an edition in one-half the time and secure a better print than on our Washington.” \*\*\* “ The press is so simple that the veriest novice can set it up, and so light-running that a boy may operate it with ease.” \*\*\* “ It is far superior to my old Washington for speed and quality of work.”

- No. 1, 8-column folio or 5-column quarto, size of bed, 28½ × 43 inches . . . \$200 00  
 No. 2, 9-column folio or 6-column quarto, size of bed, 33¾ × 48½ inches . . . 225 00  
 No. 1. Floor space, 31 × 55. . . . . Weight, 700 pounds. . . . . Shipping weight, 975 pounds.  
 No. 2. Floor space, 35 × 60. . . . . Weight, 800 pounds. . . . . Shipping weight, 1100 pounds.  
 Frisket for No. 1 extra, \$6.00; for No. 2, \$6.50.

## IDEAL INKING APPARATUS.

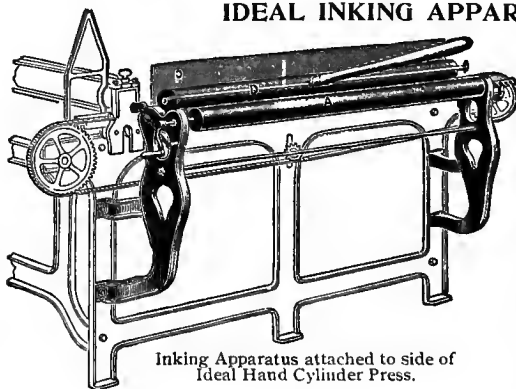

Inking Apparatus attached to side of Ideal Hand Cylinder Press.

There are two inking cylinders (A and B), one of which (A) revolves by means of the hand crank, and while revolving it automatically vibrates. The inking roller (D) rests on the inking cylinders and receives its supply of distributed ink. When the roller (D) is pushed toward the form, the automatic sheet-steel drop-leaf ink table (C) descends on the bed of the press and the roller (D) passes easily on to the type form. When the roller returns, the ink table (C) resumes its perpendicular position automatically. The Ideal Inking Apparatus is not furnished with the Ideal Press unless specially ordered.

- No. 1, for 8-column folio or 5-column quarto . \$30 00  
 No. 2, for 9-column folio or 6-column quarto . 32 00

### Hand Roller with Two Handles, including Extra Core:

- No. 1. 20 inches long, for 8-column single page . . . \$3 75  
 No. 2. 22 inches long, for 9-column single page . . . 4 25

IMPROVED COUNTRY PROUTY.

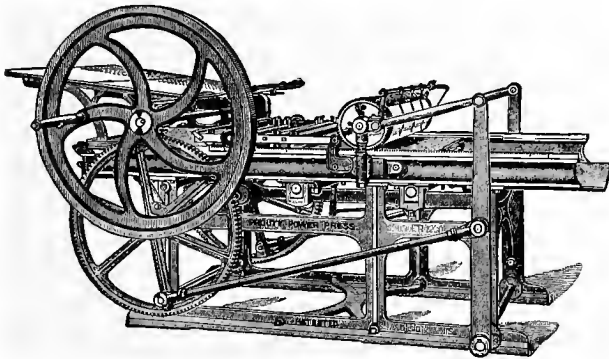

Square sides, patent square drop bed and throw-off. Self-inking. The cylinder rolls over the type form after taking the sheet from the feed-board. The rollers follow the cylinder over the type form.

	Size, inside bearers, in.	Weight, pounds.	
No. 1, 7-column folio	. 27 × 37	3600	\$600 00
No. 2, 8-column folio .	. 27½ × 43½	4000	700 00
No. 3, 6-column quarto .	. 32½ × 46½	4600	800 00

The above prices include well fountain, rubber blanket, set of cast rollers, set of extra cores, and patent throw-off and impression lock. All boxed and on-board cars. Steam fixtures, \$15.00 extra.

ARMY PRESS.

This is the lowest-priced press on which a newspaper of small circulation can be printed. The cylinder is stationary, but adjustable for impression by regulating screws at each end. The bed and form pass under the cylinder, and an impression is taken at each forward and backward movement.

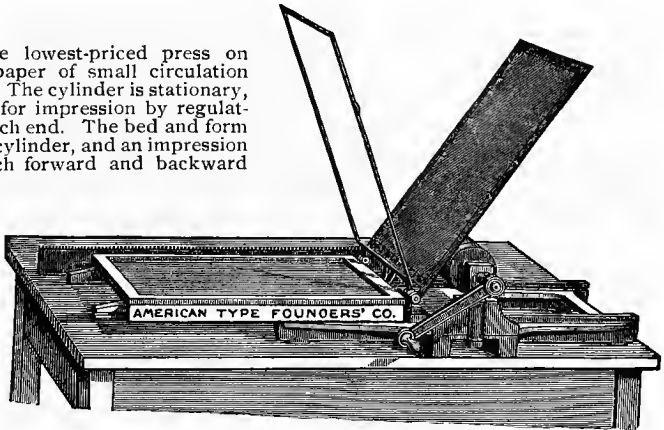

To print one page, 6-column folio, 14 × 20 inches	\$ 60 00
To print one page, 7-column folio, 16¾ × 22¾ inches	85 00
To print one page, 8-column folio, 19¼ × 25½ inches	120 00
To print two pages, 5-column folio, 19¼ × 26 inches	125 00

Two chases, six patent quoins, roller frame and cast roller, oiler and wrench, go with each press.

CAMPBELL COUNTRY HAND CYLINDER PRESS.

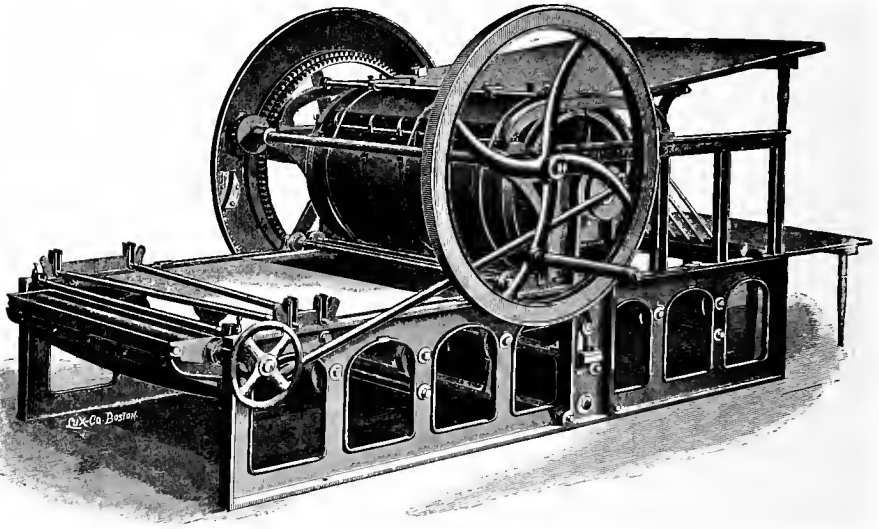

The Campbell Country Hand Cylinder forms a class by itself, and occupies, without a satisfactory rival, the entire field between the Washington hand press and the power cylinder. Thousands are in use, and it has proved a stepping-stone to fortune for a great number of publishers during the past thirty years. It is constructed on the same successful mechanical principles as are used in building the more expensive power cylinder presses, and power fixtures may be added at a small cost. The wear of type on this press is much less than on that class of presses which are constructed on the crude principles of a proof press.

No. 2. Bed, 33×48 inches. Form, 28×44 inches. Standard size for 9-column folio and 6-column quarto	\$800 00
No. 3. Bed, 30×43 inches. Form, 25×39 inches. Standard size for 8-column folio and 5-column quarto	700 00

A rubber blanket, one set composition rollers, extra set stocks, tapes, wrenches, boxing and shipping, are furnished with these presses.  
Tight and loose pulleys and belt shifter for power, \$15 00 extra.

TESTIMONIALS SELECTED FROM HUNDREDS EQUALLY FAVORABLE.

*J. H. Wilcox, Portsmouth, Va.:* "You are mistaken as to my having purchased a Campbell Hand Cylinder Country Press in 1890. I bought one in 1886, and I take great pleasure in saying that it has proved in every way most satisfactory. One small man can turn it continually for hours with ease. It does not get out of order except through negligence, and it is very simple in its operation. This press, I believe, is about sixteen years old, if not older, and it will probably last another sixteen years, if not longer."

*Theo. P. Wilson, Winchester, Mass.:* "The Campbell Hand Cylinder Country Press purchased from you in August, 1889, has given the utmost satisfaction during its over two years of constant service. I have not spent a cent for repairs, and consider it as good as when first set up. The press is now run by water power, and can print 900 papers per hour. The *Star* I consider one of the cleanest printed papers in this section."

*Paragraph Publishing Co., Mamaroneck, N. Y.:* "We take great pleasure in saying that the Campbell Hand Cylinder Press purchased of you in September, 1890, has proved in every respect a first-class machine. Although intended to be run by hand, we have been running our press by power for the last three months at an average speed of 840 to 900 per hour. As the press has no springs, we consider this a performance with which we are pleased, and of which you have reason to be proud."

*T. H. Horter, Middleburgh, Pa.:* "I have been using a Campbell Press for four years, and take pleasure in recommending it to the trade. For simplicity, durability and ease on type it cannot be excelled. My issue of 1600 (6-column quarto) is turned off in two and a half hours, including all stops, and the press hasn't been out of order since I had it, with the exception of the fly-spring breaking. I would not trade it with any press on the market for a country office."



**COTTRELL TRIUMPH COUNTRY PRESS.**

With Patent Air Springs.

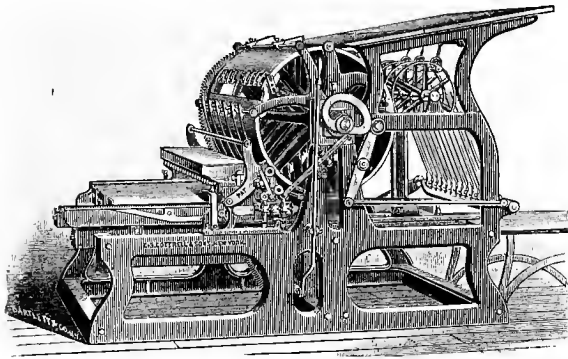

Adapted for printing newspapers, pamphlets, posters, circulars, and all classes of commercial printing. Conforms in construction, design, durability and finish to the high reputation of the manufacturers.

The press is supplied with patent air springs, the resistance of which is increased or decreased according to the speed of the press. It is well known that the faster the speed the greater strength of spring is required. The patent air spring covers these requirements. If the press is running at five hundred per hour, the spring can be easily regulated for that speed; and if running at fifteen hundred per hour, the proportionate increase of spring can be obtained, and so up to the highest speed of which this press is capable. The air spring is provided with an automatic throw-off that releases the pressure when the press is stopped, and the pressman can move the bed to and fro without compressing the spring. When the press is started, the spring is applied automatically.

The patent hinged roller-frame permits of the rollers being instantly uncovered for removal or for other purposes without unscrewing the sockets. The rollers can be taken out and put back without changing their set. The well-fountain is used, being easily regulated and cleansed, and it is set high, giving easy access to the form. The distribution is ample—two three-inch rollers covering the full form. The bed has four supports while under impression, thus securing a clear, even impression. The shoes, tracks and rollers are of hard steel. The gearing is accurately cut, which, together with the registering rack and segment, insures perfect register.

The Triumph Press is built with table, rack and cam distribution, or with the rack and cam distribution, as per illustration on this page.

The Triumph Press can be fitted to run by hand power, when so desired. Tapeless delivery furnished, when required, at an extra charge.

**Sizes and List Prices with Rack and Cam Distribution.**

	Size of bed inside bearers.	Size of form covered by rollers.	List Price
No. 3	. 26×37 inches	22×33 inches	\$1000 00
No. 5	. 33×47 inches	28×43 inches	1100 00

Steam fixtures, extra, \$50 00. Tapeless delivery, extra, \$75 00. Table, rack and cam distribution, extra, \$75 00.

Price includes rubber blanket, wrenches, two sets of roller stocks, roller moulds, boxing and shipping.

## COTTRELL MONARCH TWO-ROLLER PRESS.

With Two Rollers Covering Form.

Air Springs.  
Tapeless Delivery.

Back-Up Movement.  
Hinged Roller-Frame.

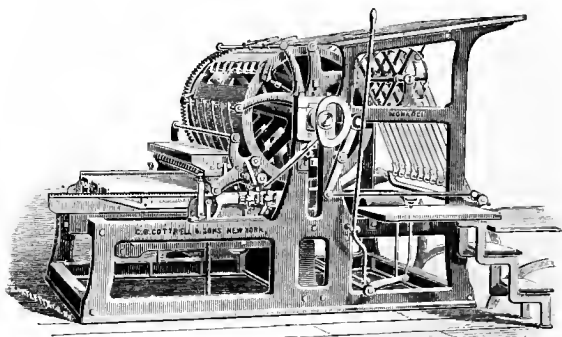

It has many advantages and improvements, including patent air springs, patent tapeless delivery, back-up movement, hinged roller-frame, and iron steps and feeder's stand, and in its manufacture quality is placed first and cost afterward.

It is a press of excellent design, of the best materials, and of high speed. By manufacturing them in large quantities, and building but two sizes, the price is put within the reach of the printer of moderate means.

It is a fast press—1600 per hour is easily possible on the larger and 2000 on the smaller size.

It has four bearings under the bed for extreme rigidity and strength, and steel tracks and steel rollers. There is a heavy flange on the ends of the cylinder as an added element of strength.

The patent air spring forms an easy cushion for the bed in passing the centers, is under perfect control, and can be readily adjusted for the different speeds. The air spring has a new automatic throw-off, so that in turning over the centers by hand the spring is not compressed.

The patent back-up movement is a great convenience and a labor-saver.

The patent hinged roller-frame permits the form rollers to be instantly uncovered for removal or other purposes without unscrewing the sockets. The rollers can be taken out and put back without changing their set.

The well fountain is used, being easily regulated and cleaned. It is set high, giving easy access to the form.

Furnished with table and rack and cam distribution at an extra charge, or only with rack and cam distribution as illustrated.

### Sizes and List Prices, with Rack and Cam Distribution.

Size of bed inside of bearers.	Size of form covered by two rollers.	List Price.
No. 3, 26×37 inches . . . . .	. 22×33 inches . . . . .	\$1500 00
No. 5, 33×47 inches . . . . .	. 28×43 inches . . . . .	1800 00

Table distribution, \$75 00 extra.

Price includes hard-packing or rubber blanket, wrenches, two sets of composition roller stocks, roller moulds, countershaft, two hangers, two four-speed cone pulleys and driving pulley, boxing and shipping.

**COTTRELL PARAGON JOB AND NEWSPAPER PRESS.**

With Two Rollers Covering a Full Form.

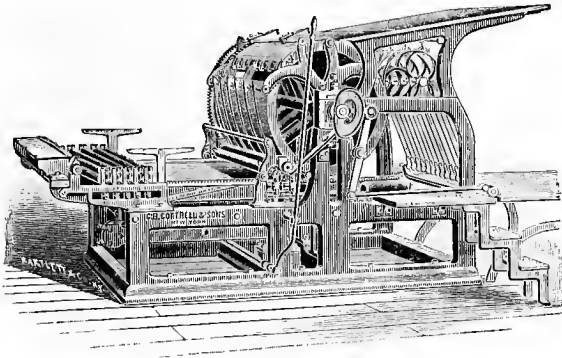

The side frames rest upon and are fastened to a substantial bed-plate, thus insuring stiffness and rigidity of construction. The side frames are changed in design, the flanges projecting inward, and are massive in appearance.

The girt is cast solid with the bed-plate, and carries a pair of substantial rollers adjustable in their box bearings. These rollers operate in connection with extra steel tracks beneath the bed, which, with the ordinary ribs, sliders and tracks, form four separate bearings directly beneath the "impression," making any spring in the bed an impossibility.

The patent air spring, as applied to the press, forms an easy cushion for the bed in passing the centers, and can be readily adjusted for the different speeds.

In connection with the air spring is an automatic throw-off, which permits of the press being turned by hand without compressing the spring. This device is entirely automatic, and does not require any attention.

These presses are supplied with the well-fountain, placed high above the bed, to admit of easy access to the form. The roller frames are hinged in such a manner as to enable the pressman to open them in an instant, leaving the form rollers free for removal. The roller bearings are made adjustable in every direction.

The sheet delivery is tapeless, and fingers of the fly are adjustable transversely to suit position of delivery wheels and nature of sheet to be delivered. The ends of the cylinder are flanged to increase its rigidity.

The Paragon Press is supplied with table, rack and cam distribution, as illustrated on this page, at an extra charge, or with rack and cam distribution.

**Sizes and List Prices, with Rack and Cam Distribution.**

No.		Size of bed inside bearers.	Size of form covered by two rollers.	List Price.
No. 5 . . .		33×47 inches	29×43 inches	\$1900 00
No. 6 . . .		33×50 inches	29×46 inches	2000 00
No. 7 } Flange Frames	}	34×52 inches	31×49 inches	2200 00
No. 8 }		37×54 inches	34×51 inches	2500 00

Table distribution, \$75 00 extra.

Price includes hard-packing or rubber blanket, wrenches, two sets of composition roller stocks, roller moulds, countershaft, two hangers, two four-speed cone pulleys and driving pulley, boxing and shipping.

**THE CRANSTON PRESSES.**

These presses have always been built on high-grade lines. The motto of the maker, painted conspicuously in the factory, "First learn to do a thing well, then learn to do it quickly," has been consistently carried out, and it can safely be affirmed that the Cranston presses are unexcelled in fine workmanship, true mechanical principles, and superior materials, all which result in durability, smoothness, and general satisfaction. The new series of 1897 have numerous up-to-date improvements, and some sizes have been changed for the better convenience of printers. The numerous users of Cranston presses will be more than pleased with the new series.

**THE CRANSTON NEWSPAPER PRESS.**

**Two-Roller,  
With Rack and Pinion Distribution.**

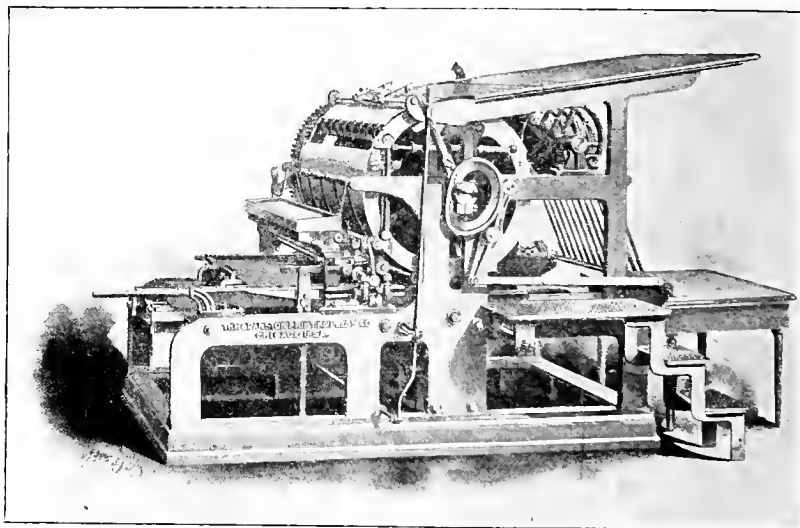

Built of the best material; furnished at a moderate price; put to practical tests; it has proved by constant use to be an economical press to buy. The runners on both track and table are steel; the shafts, rolls, studs, shoes and wearing parts are also steel. All gears and racks are cut from the solid. The press is provided with air springs, tapeless delivery, noiseless gripper motion, continuous fly cam, adjustable feed guides. The fountain is placed high on the stand, thus giving easy access to bed of press. The form rolls are made of wrought iron pipe, and are of large size, easily placed in position and adjusted. There is a brake, a fountain cover, reel rod for blanket and tympan, and a guard for distributing rack. Distribution is controlled by cam movements.

Size.	Inside Bearers.	Matter Covered.	Length of Base.	Width of Base.	Weight Boxed.	Price.
No. 3½.	33×48.	28×44.	7 ft. 7½ in.	5 ft. 3½ in.	9000 lbs.	\$1600 00

An additional charge for table distribution.

Each press is furnished with overhead fixtures complete (except when furnished with hand power only), blanket, wrenches and one set stocks, also one extra set stocks and iron steps.

THE BEST OF EVERYTHING FOR THE PRINTER

## THE CRANSTON IMPROVED NEWSPAPER PRESS.

Two-Roller, with Rack and Pinion Distribution.

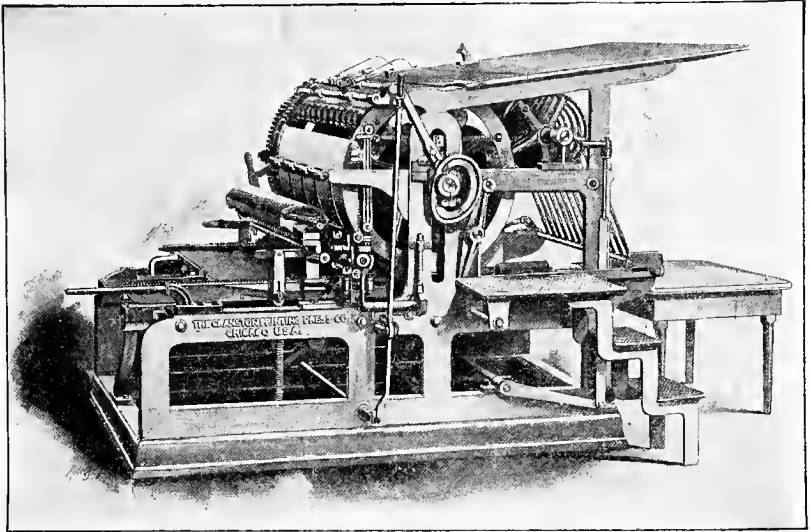

The Improved Newspaper Press has been materially changed in construction and general appearance. All racks and gears have wide faces, and are cut from the solid. The press has air springs; tapeless delivery—wheels adjustable to any size sheet; patented device for controlling motion of sliders; patent stop and reversing motion; noiseless gripper motion; continuous fly cam; feed guides that are capable of the finest adjustment; large size form rollers; long register rack and segment; deep fountain; cover for fountain; convenient arrangement for adjusting fountain roll; cylinder distribution.

Every convenient feature that the price at which it is offered will permit is put on this press, effecting a saving of time and labor for which the Cranston presses are well and favorably known.

Size.	Inside Bearers.	Matter Covered.	Length of Base.	Width of Base.	Weight Boxed.	Price.
No. 3½ . . .	33×48 . . .	28×44 . . .	7 ft. 7½ in. . .	5 ft. 3½ in. . .	950 lbs. . .	\$1800 00
Table distribution extra.						

Each press is furnished with overhead fixtures complete, blanket or hard packing, wrenches, iron steps, two complete sets stocks—one set cast with composition ready for immediate use.

## THE CRANSTON IMPROVED BOOK AND NEWSPAPER PRESS.

Two-Roller, with Rack and Pinion Distribution.

The Improved Book and Newspaper Press has all of the features which made the Improved Newspaper Press the best newspaper press in the market, and in addition has a separate heavy cast-iron base plate which gives additional strength and solidity to the machine, and makes it possible to run it at a higher rate of speed without jar or injury to the press. It is especially designed for fine book, newspaper and general job printing. For accuracy of register and convenience of making ready, it is unexcelled. The workmanship and wearing qualities are unsurpassed.

Size.	Inside Bearers.	Matter Covered.	Length of Base.	Width of Base.	Weight Boxed.	Price.
No. 3½ . . .	33×48 . . .	28×44 . . .	7 ft. 7½ in. . .	5 ft. 3½ in. . .	10,000 lbs. . .	\$2200 00
Table distribution, extra . . . 100 00						

Each press is furnished with overhead fixtures complete, blanket or hard packing, wrenches, iron steps, two complete sets stocks—one set cast with composition ready for immediate use.

## THE CRANSTON PATENT IMPROVED TWO-ROLLER PRINTING PRESS.

For Fine Book, Commercial and Newspaper Printing.

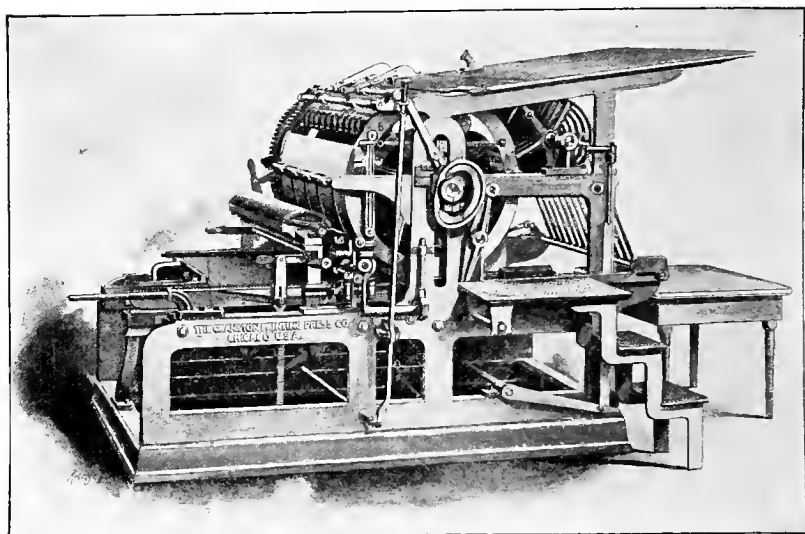

This press is carefully made in every detail. The stock and finish are unexcelled. The tracks are wide, and provided with steel rolls and runners. The wearing parts—shafts, knuckles, shoes, studs—are of steel. The gears and racks are cut from the solid, and have wide faces. The press has air springs; patent silent slider motion, which insures uniform travel of the sliders with the table; patent stop and reversing motion; improved feed guides; patent adjustable side-guide leaf on feed table, which can be set for the greatest precision of register.

The fly is operated by a silent motion, the cam having a continuous surface.

The fountain basin is deep, and will carry a large supply of ink. It is placed high on the stands, and easy access is thus given to the bed of the press.

The Cranston combines the essential features: great strength, unyielding impression, fine distribution, exact register, with convenience in adjustments and make-ready. It is operated with light power, and cannot but give satisfaction both in quantity and quality of work produced.

Size.	Inside Bearers.	Matter Covered.	Length of Base.	Width of Base.	Weight Boxed.	Price.
*No. 0	18 × 25	13 × 21	5 ft. 4 in.	3 ft. 3 <sup>3</sup> / <sub>4</sub> in.	4,500	..
*No. 1	21 × 28	16 × 24	5 ft. 8 <sup>3</sup> / <sub>4</sub> in.	3 ft. 8 <sup>1</sup> / <sub>4</sub> in.	5,500	..
*No. 1½	21 × 36	16 × 32	5 ft. 8 <sup>3</sup> / <sub>4</sub> in.	4 ft. 4 <sup>1</sup> / <sub>2</sub> in.	6,500	..
*No. 1A.	24 × 30	19 × 26	6 ft. 2 <sup>1</sup> / <sub>2</sub> in.	3 ft. 10 <sup>1</sup> / <sub>4</sub> in.	6,500	..
No. 2	25 × 36	22 × 32	6 ft. 5 <sup>1</sup> / <sub>2</sub> in.	4 ft. 6 in.	7,500	..
No. 2A.	25 × 38	22 × 34	6 ft. 8 <sup>3</sup> / <sub>4</sub> in.	4 ft. 7 <sup>3</sup> / <sub>4</sub> in.	8,500	..
No. 2½	29 × 43	24 × 39	7 ft. 4 <sup>1</sup> / <sub>2</sub> in.	5 ft. —	10,000	..
No. 3	32 × 46	27 × 42	7 ft. 9 <sup>3</sup> / <sub>4</sub> in.	5 ft. 4 <sup>1</sup> / <sub>2</sub> in.	10,500	..
No. 3½	33 × 48	27 × 44	7 ft. 9 <sup>3</sup> / <sub>4</sub> in.	5 ft. 5 in.	11,000	..
No. 4	34 × 50	29 × 46	8 ft. 4 in.	5 ft. 9 <sup>3</sup> / <sub>4</sub> in.	13,000	..
No. 5	36 × 52	31 × 48	8 ft. 8 <sup>1</sup> / <sub>2</sub> in.	5 ft. 9 <sup>3</sup> / <sub>4</sub> in.	13,500	..
No. 5½	38 × 54	33 × 50	9 ft. —	5 ft. 11 <sup>1</sup> / <sub>2</sub> in.	14,000	..

\* Commercial Series.

Each press is furnished with overhead fixtures complete, blanket and hard packing, wrenches, iron steps, and two complete sets stocks.

THE CRANSTON-VICTOR TWO-REVOLUTION PRESS.

Two-Roller.

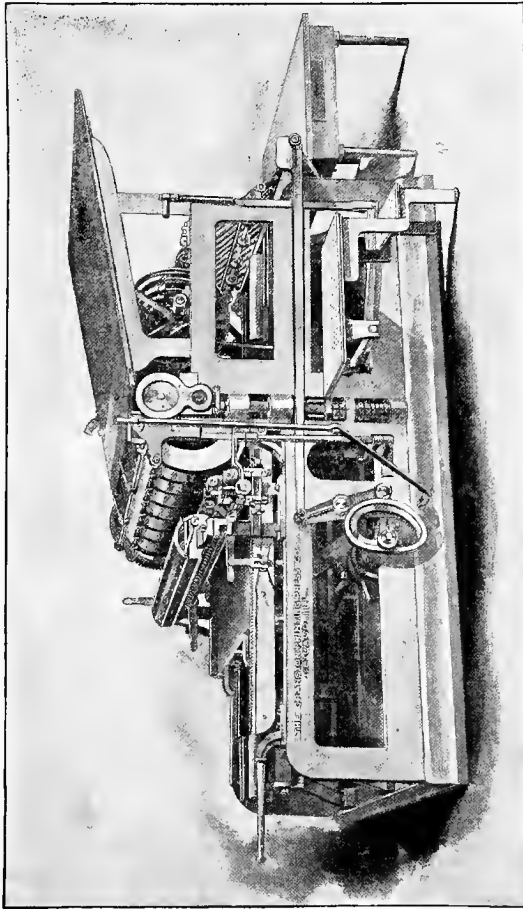

The track has wide runners, laid with steel. The table has three supports—two in the track, one on a center bearing placed on the girt—thus giving three continuous bearings through the line of impression without interference of a third track. Cylinder and lifting shafts, rolls, shoes, knuckles, are of steel. The smaller parts are built with a view to the greatest possible wear.

The mechanism for lifting the cylinder is simple, effective, and controlled by cam movements. No strain and no wear. Steel bearings.

The press has air springs; patent device for controlling motion of sliders; all gears and racks have wide faces, and are cut from the solid; distribution unailing; large size form rollers, with bearings convenient and secure, easily placed in position and as easily removed; fly cam with continuous surface; deep fountain basin; arrangement for adjusting fountain roll; cover for fountain; adjustable bearers; hard-wood feed table; patent improved feed

guides and side guide leaf on feed table; patent stop and reversing motion; automatic leaf-lifting device for preventing the tongues or guides from catching and tearing the tympan while reversing press; arrangement for throwing reel wheels on or off while making ready. The movements are all conveniently and easily adjusted, and positive in their action.

The speed of this press is all that can be obtained from any press of corresponding size and style.

Size.	Inside Bearers.	Matter Covered.	Length of Base.	Width of Base.	Weight, Boxed.	Price.
No. 4.	34 x 50 inches .	30 x 46 inches .	8 feet 6 inches .	5 feet 7 1/2 inches .	14,500 lbs. . . . .	
No. 5 1/2.	38 x 54 inches .	34 x 50 inches .	9 feet 6 1/2 inches .	5 feet 11 1/2 inches .	16,000 lbs. . . . .	
No. 6.	42 x 60 inches .	37 x 56 inches .	10 feet . . . . .	6 feet 3 inches . . . . .	17,500 lbs. . . . .	

Each press is furnished with overhead fixtures complete, blanket or hard packing, wrenches, iron steps, two complete sets stocks—one set cast with composition ready for immediate use.

THE CRANSTON-VICTOR COMMERCIAL PRESS.

Two-Revolution, with Four Rollers

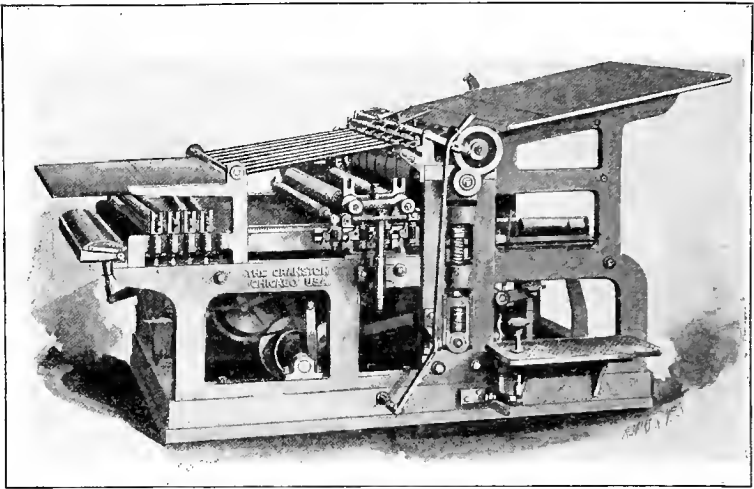

Various methods of engraving having been developed, and their utility practically demonstrated, the demand has been created for a press that will bring out delicate lines of half-tone, process, etched, photo-engraved plates, and work of this description, giving that clear and distinct impression without which the best results are not attainable from such plates. The new Victor Two-Revolution Four-Roller Commercial Press is especially designed for this class of work. Possessing as it does the patented features of our larger sizes, it is, like them, solidly constructed, giving an *unyielding impression* and an *ample inking surface*. Its size is convenient and sufficiently large to meet all demands for work of this class, while the speed provides for rapid production. Many features are embodied in this press for convenience in make-ready, etc. The distribution is a complete system, by means of which every particle of inking surface is *evenly and thoroughly* covered. The movements are easily adjusted and positive in their action. The cam has a continuous surface, and the sheets are laid lightly on the table without smut or off-set. Adjustable fly-fingers. The height of the press is such that it can be fed from the floor, and it is built with special reference to convenience in working about it. Its register is *faultless*. This press is the result of careful study, and embodies suggestions from practical printers regarding the requirements for printing this special work. The very satisfactory results obtained from those in use prove conclusively that the Victor will meet all requirements made upon it.

The speed is equal to all reasonable demands for fine printing.

Size.	Inside Bearers.	Matter Covered.	Length of Base.	Width of Base.	Weight Boxed.	Price.
No. 2A . . .	25" 3/8 in. . .	22" 3/4 in. . .	6 ft. 5 1/4 in. . .	4 ft. 5 1/4 in. . .	750 lbs. . .	

Each press is furnished with overhead fixtures complete, blanket or hard packing, wrenches, two complete sets stocks.

**A WISE PURCHASE.**

The No. 2A Cranston-Victor Press is a money-maker. Fine job printing, from small circulars to any size within its capacity, can be done at high speed and with the finest results. In a printing establishment doing general work of all grades this press will prove exceedingly useful and profitable. Its construction and features are such that making ready can be done quickly. It takes in a great range of work which cannot be so profitably printed on a larger press.



# THE CRANSTON-VICTOR TWO-REVOLUTION PRESS.

Four-Roller.

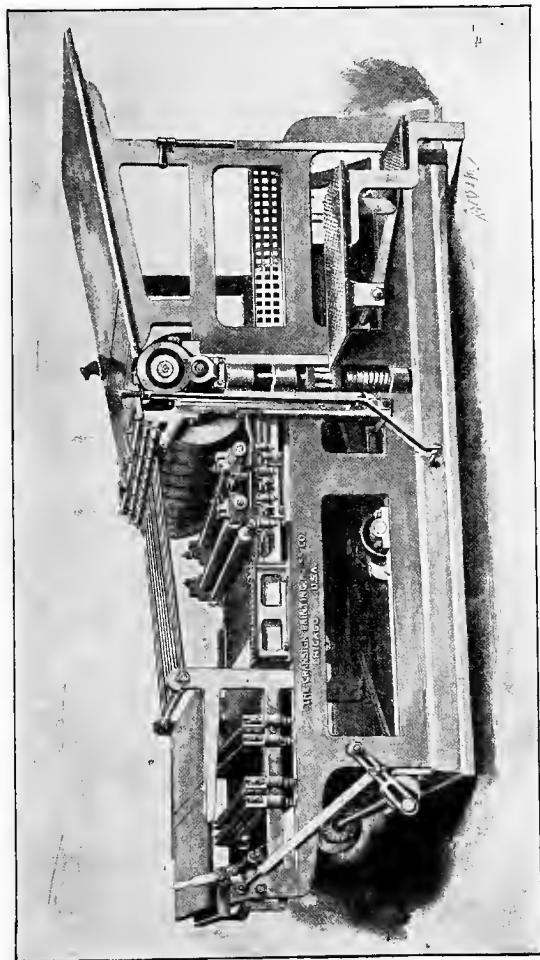

less delivery. The down-delivery attachment gives a positive and unfailing delivery of sheets on the fly table. As far as practicable on all our presses, the adjustments are made with thumb nuts. The sliders to the table by our patent slider motion, and uniformity in travel is thereby insured. The patent feed guides and adjustable side-guide leaf on feed table can be adjusted with the utmost precision without leaving the feeder's platform. Reel wheels are readily thrown on or off while making ready. The patent stop and reversing motion enables the feeder to stop the press instantly at any desired point, and run it backward, thereby effecting economy of time and labor, as he has absolute control of the press without leaving his position. The automatic leaf-lifting device prevents the tongues or guides from catching or tearing the tympan while reversing press.

Size.	Inside Bearers.	Matter Covered.	Length of Base.	Width of Base.	Weight Boxed.	Price.
No. 4	. 34 x 50 inches .	. 29 x 46 inches .	9 feet 6 1/2 inches .	5 feet 7 1/2 inches .	17,500 lbs. .	_____
No. 5 1/2	. 38 x 54 inches .	. 34 x 50 inches .	9 feet 6 1/2 inches .	5 feet 11 1/2 inches .	18,500 lbs. .	_____
No. 6	. 42 x 60 inches .	. 37 x 56 inches .	10 feet .	6 feet 3 inches .	19,500 lbs. .	_____

Each press is furnished with overhead fixtures complete, blanket or hard packing, wrenches, iron steps, two complete sets stocks—one set cast with composition ready for immediate use.

The entire frame of the press is solid and compact. The tracks on both the table and runners are wide, laid with steel, and the rolls traversing on them are of the same material accurately gauged to size. The lifting mechanism for the cylinder is a direct cam motion, plain in construction, smooth running, operated with light power, requiring no weight. The shafts, cams, knuckles, studs, rolls, shoes, and all wearing parts, are of steel and built with view of greatest possible resistance to wear. The shoes are securely fastened and dowelled to the rack hangers. The cylinder has heavy flanges. The impression surface is strongly braced and supported. The press has hard-wood feed table; fly cam with continuous surface. Ample provision is made securing distribution and register.

This is a press that can be easily handled with movements plain and direct in action, adjustments readily and conveniently made, resulting in the greatest economy of time and labor.

This press is provided with a trip, which may be thrown on or off at any point of the stroke of bed.

The reciprocating motion of the table is controlled by air springs which are simple and effective, having a plain valve which is in itself direct acting without any complicated attachments. The sheets are delivered to the fly by the tape

## OSTRANDER-SEYMOUR PONY WEB PERFECTING PRESS.

A Reliable Low-Priced Perfecting Press.

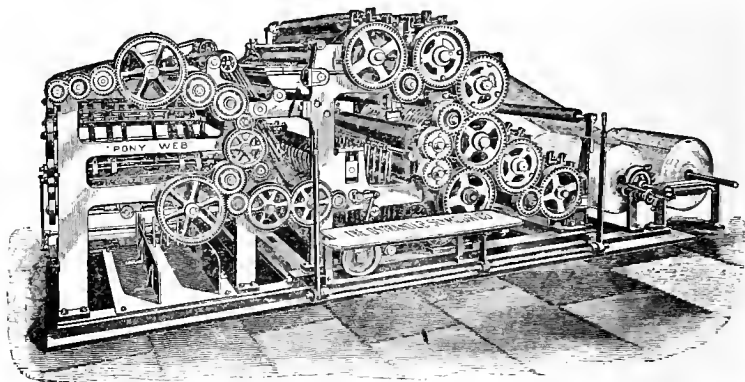

This press is designed for newspapers with a circulation which cannot be handled satisfactorily on flat-bed cylinders, but which could not profitably utilize high-priced and more elaborate perfecting presses. The Pony Web can be worked economically, will do the work equal to a press costing twice as much, and can be depended upon for durability, based on good materials and good workmanship.

This Pony Web Press is complete with stereotyping apparatus, make-up tables and chases, and will print four-page or eight-page papers of either 6 or 7 columns, or 7 or 8-column sizes, at a speed of from 10,000 to 12,000 per hour.

Prices, terms and full particulars sent on application. Can be built to order for special work at moderate additional cost.

### LETTER FROM A USER.

AMERICAN TYPE FOUNDERS COMPANY, Buffalo, N. Y.

BUFFALO, N. Y., August 4, 1897.

Dear Sirs:

At your request I take pleasure in expressing my satisfaction with the Ostrander Web Press you put in my office. It is run with very little trouble by my old pressman who had no previous experience in either stereotyping or in running a web press. We get eight stereos made and the first 3500 papers off within an hour after the forms are received from my composing room. For comparatively green hands, this is good work. We run right along at a rate of from 9000 to 12,000 per hour. We frequently run several days without breaking the web, or being obliged to stop once, except for putting on new rolls of paper. As for the quality of the work, the *Mercantile Review* speaks for itself. I believe we will do even better when we get a little more experience. You are at liberty to refer any inquiries to me, as the press certainly handles my paper in good shape.

Very truly,

CHARLES H. WEBSTER.

---

GENERAL SELLING AGENTS,  
AMERICAN TYPE FOUNDERS COMPANY.

**COMBINATION PAPER JOGGER.**

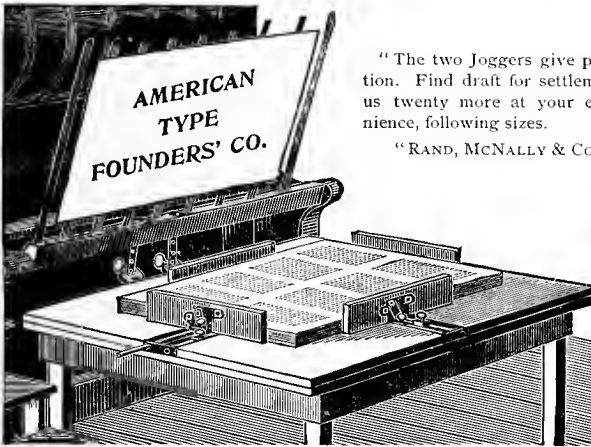

"The two Joggers give perfect satisfaction. Find draft for settlement, and send us twenty more at your earliest convenience, following sizes.

"RAND, McNALLY & Co., Chicago."

Made with wings, to be instantly removed if desired. No projecting rod on front side to tear clothes. This of itself is worth the price of a Jogger. Patent attachable wings for small Joggers, by which letter-heads, etc., can be evened up.

24×36 inches, or less . . . . .	\$15 00
36×48 inches, or less . . . . .	18 00
Larger than 36×48 inches . . . . .	20 00

**OVERHEAD POWER FIXTURES.**

Consisting of countershaft, two adjustable hangers with oil cups, two cone pulleys, and driving pulley for main shaft.

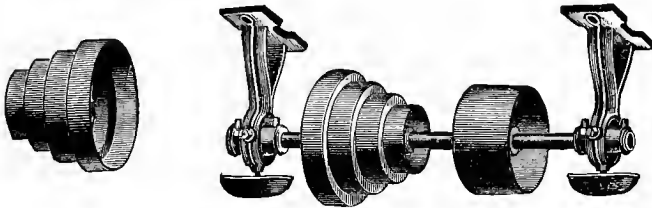

**LIGHT FIXTURES FOR EIGHTH MEDIUM PRESSES AND SMALLER.**

No. 1—3 speed, 6 to 9 inches, belt 1½ inches . . . . .	\$15 00
No. 2—4 speed, 7 to 10 inches, belt 1¾ inches . . . . .	18 00

**HEAVY FIXTURES.**

No. 3—3 speed, Eighth Medium . . . . .	\$20 00
No. 4—4 speed, Eighth Medium . . . . .	22 50
No. 5—3 speed, Quarto Medium . . . . .	22 50
No. 6—4 speed, Quarto Medium . . . . .	25 00
No. 7—3 speed, Half Medium . . . . .	27 50
No. 8—4 speed, Half Medium . . . . .	30 00

Shafting, Hangers, Pulleys and Collars Furnished to Order at the lowest prices.

TRIBUNE NEWSPAPER FOLDER.

All Iron Frame.  
Working Parts Steel and Iron.  
All Movements Positive.  
No Sprocket Chains.  
No Lost Motion.

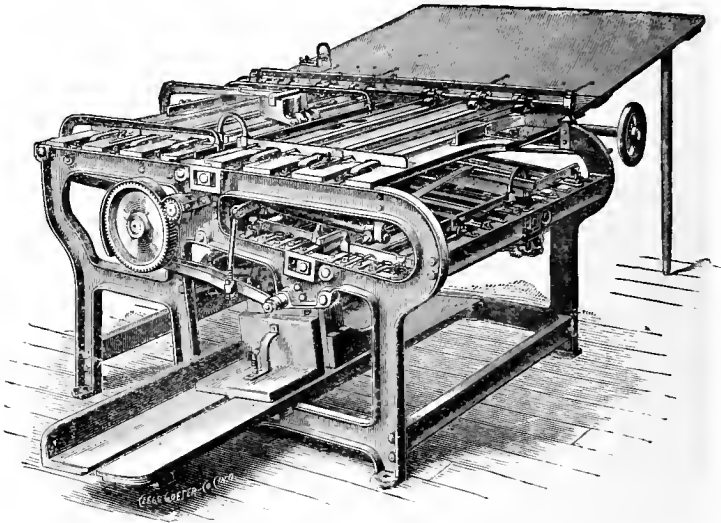

This is a folder of the highest grade of construction and efficiency, without a superior for its purpose on the market, and sold at such moderate net prices as to make so-called "cheap" folders highly expensive in comparison—durability and reliability considered. It has no makeshift devices. It folds on the same principle as the high-grade book machines. The simplest folder made.

Made in one size only, 36×48 inches, which takes in any size sheet, whether folio or quarto, from 22×32 to 36×48 inches.

Paster and trimmer can be furnished at time of purchase or added afterward.

Made with three- and four-fold deliveries. Three-fold work is delivered in a receiving box, while four-fold work is delivered in a packer, as shown in illustration.

In the hands of a competent operator it will fold ordinary sixteen and thirty-two page work.

Weight about 900 pounds. Power required, about one-tenth of one horse-power. Speed, 3000 folio or quarto sheets per hour.

LIST PRICES.

For hand feed . . . . .	\$400 00
Paster and trimmer . . . . .	25 00
Fixtures for attaching to press, net . . . . .	50 00 extra.
Two- and four-page inseting attachment, net . . . . .	100 00 extra.
Two- and four-page covering attachment, net . . . . .	100 00 extra.

Circulars and discounts on application.

The net price of this thoroughly reliable and durable Folder is very little more than asked for inferior affairs which in the end will prove to be most expensive and least satisfactory. This Folder is made to do perfect work for many years.

**BENNETT ECONOMICAL FOLDER.**

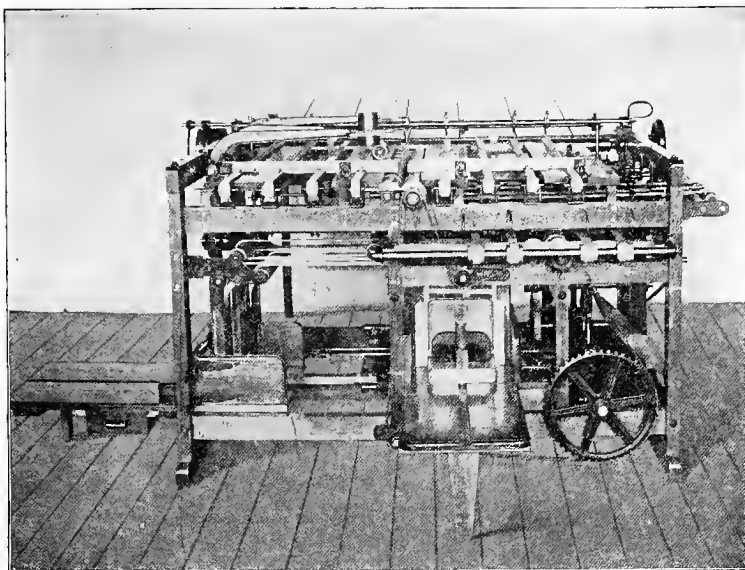

Has a strong, wooden frame, with working parts of iron. Delivers at third and fourth folds, and can be changed without stopping machine. Has pasting and trimming attachment for eight (8) page work. Built in hand-feed, or attachable to any cylinder press, front or back delivery. All journals are of tool steel, with journal boxes three diameters long, hung in self-adjusting pivot hangers, making it possible to remove any fold roll, driving or rock shaft in a few moments and replace in line, and there is not a gear on the machine but can be reached conveniently, and removed easily. All adjustments are made by screw, each tape tightened independently, and drop of fold blades can be regulated by the "turnbuckle" adjustment to one-hundredth of an inch. There are side guides to insure accuracy in folding, whether a sheet comes from a press or feed-board.

No extra charge for press fixtures in attachable machines, except for front-delivery press.

**LIST PRICES.**

32×44 (6-Column Quarto), or 36×50 (7-Column Quarto), including Paster and Trimmer . . . . .	\$240 00
Folio Supplement Attachment, with Paster . . . . .	50 00
Quarto Supplement Attachment, with Paster . . . . .	85 00
Folio and Quarto Supplement Attachment, combined . . . . .	125 00
Cover Attachment for eight pages . . . . .	100 00
Fifth or Post-office Fold . . . . .	50 00
Hand Feed and Attachable in one machine . . . . .	50 00
Attachments for Front-Delivery Press . . . . .	25 00

**THE BENNETT COUNTRY QUARTO FOLDER.**

This machine is exactly the same as the Economical Folder, except that, instead of regular packing boxes at the third or fourth fold, it has a packing box at the fourth fold and a drop box at the third fold.

6 or 7-Column Quarto, including Paster and Trimmer . . . . .	\$200 00
Hand feed or attachable to press.	

**EMMERICH BRONZING MACHINE.**

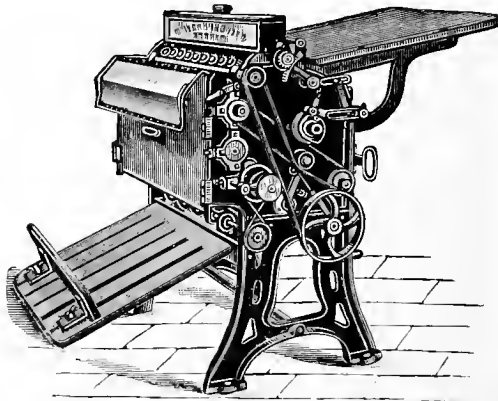

Over one thousand of these excellent machines are in use, and all give satisfactory results. They apply the bronze, polish and remove the superfluous powder, and deliver the sheet, bronzed side up, at a speed of two thousand on the smaller sizes. They are self-adjusting for all thicknesses of paper. They are made to be belted to a main shaft, and are equipped with belt shifter and tight and loose pulleys.

No.	Maximum Capacity.	Floor Space.	Weight Pounds.	Speed of Driving Pulley.	Diameter Driving Pulley.	Price f. o. b. factory.
1 . . .	9×15	24 × 30	320 .	330	6 inches .	\$300 00
2 . . .	14×25	30 × 37	390 .	360	6 inches	375 00
3 . . .	16×30	44 × 50	600 .	110	10 inches	475 00
4 . . .	20×35	48 × 54	750 .	105	10 inches	550 00
5 . . .	25×40	54 × 58	900 .	90	10 inches	650 00
6 . . .	28×44	57 × 60	1050 .	140	13 inches	750 00
7 . . .	34×50	62 × 65	1225 .	140	13 inches	850 00
8 . . .	36×54 . . . . .	65 × 70	1350 . . . . .	140 . . . . .	13 inches	925 00

**EMMERICH CARD BRONZING MACHINE.**

Specially constructed for bronzing heavy stock that will not conform to a cylinder, such as photograph mounts, thick cards, etc. Both sides of cards are dusted at one operation. Forty photograph mounts per minute is the speed.

No.	Maximum Capacity.	Floor Space.	Weight Pounds.	Speed of Driving Pulley.	Diameter Driving Pulley.	Price
1	10 inches	24 × 34	350	200	8 inches .	\$
2	14 inches	28 × 37	420	200	8 inches .	—
3	20 inches	34 × 40	525	175	10 inches .	—
4	24 inches	38 × 45	650 . . .	175	12 inches . . .	—

Prices will be quoted upon receipt of sample or description of work to be done.

For Prices of Bronzes and Hand Bronzing Devices, see page 507.

**HERCULES SPECIAL GAS AND GASOLINE ENGINE.**

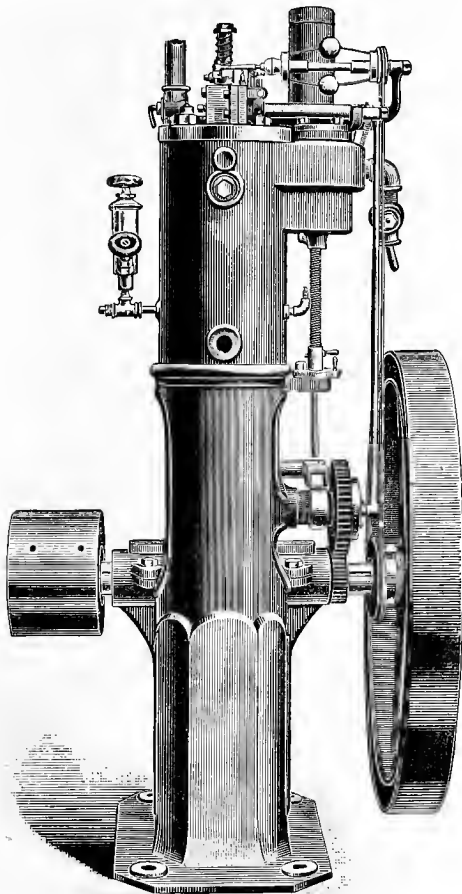

The superiority of a good gas engine to a steam engine in economy, convenience, safety, cleanliness and availability at a moment's notice is conceded by all, and more especially in offices where the use of power is intermittent; because with steam power, if used only at short intervals during a day, steam must always be kept up, and the fire and boiler constantly watched, while with a gas engine one turn of the wheel and your power is available, and when done with all expense ceases. With the gas engine there is no dirt, no coal, no engineer, no noise, no smoke, no annoyance, do danger.

The Hercules Special is a modern gas engine, built on the same substantial and durable lines as a first-class steam engine, held in a solid, heavy frame of No. 1 grade iron, with all working parts of bronze or forged steel, highly finished, with automatic governor, sight feed lubricators, and adjustable oilers.

The principle of construction is designed to get the maximum power with the minimum consumption of gas, and the consumption is automatically regulated to correspond with the power used. If only ½-horse power is used, then the consumption of gas is about one-fifth as much as if the maximum power of the engine was in use. The consumption of gas is about fifteen cubic feet per horse-power (actually used) per hour.

The gas is ignited by either an electric spark generated by the contact of two heavy, hardened steel electrodes, which are easily adjusted while engine is running, or by means of a heated metallic tube, or by both methods.

**WHEN USED AS A GASOLINE ENGINE.**

The gasoline, which may be of a cheap grade (74° test), is fed from a tank placed at a distance, and connected with the gas chamber on the side of engine. The gas passes into the mixing valve, and combines with the requisite quantity of hot air to secure perfect combustion, full power, and no smell. Full directions for making and placing gasoline tank and connecting same are sent with the engine. The gasoline engine consumes about one-eighth of a gallon of gasoline per horse-power per hour, and the consumption is in proportion to the power used.

2½ horse-power (actual) . . . . . \$185 00  
 Send for descriptive circular.

When required, the Hercules is supplied with the necessary appliances for operating by both gas and gasoline.

# FOR STOCK ROOM AND BINDERY.

## PEERLESS GEM PAPER CUTTERS.

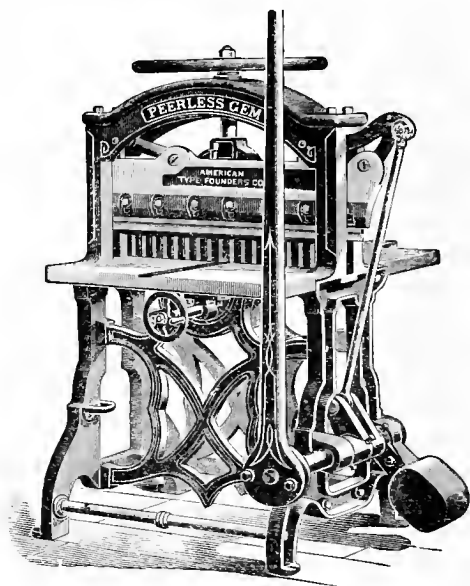

This illustrates the 30- and 32-inch Peerless Gem Paper Cutter, except that the balance weight is now hung inside the frame as shown in cuts of 23-inch size on opposite page.

Superior in every detail and in the leverage, cutting with greater ease to operator, and returning from cut with the least possible exertion, owing to their perfect balance. The frame is stronger, heavier and better braced; the knife thicker and deeper, insuring a truer cut and longer life; the lever is adjustable; the balance weight is now hung inside the frame, thus saving floor room. There are split back gauges, side gauges, and a front enameled measuring gauge. Unexcelled in construction, materials used, and finish.

Compare details of construction given below with those on other cutters.

23-inch, cuts 23 $\frac{1}{4}$ inches	\$100 00
25-inch, cuts 25 $\frac{1}{4}$ inches	125 00
30-inch, cuts 30 $\frac{1}{4}$ inches	175 00
32-inch, cuts 32 $\frac{1}{4}$ inches	200 00

### DETAILS OF CONSTRUCTION.

	Weight, Unboxed.	Thickness of Knife Bar.	Thickness of Knife.	Depth of Knife.	Diameter Lever Shaft.	Diameter Steel Lever Connection Shaft.
30-inch .	1340 lbs.	1 $\frac{3}{4}$ in.	$\frac{1}{2}$ in.	5 in.	2 in.	1 $\frac{1}{4}$ in.
32-inch .	1425 lbs.	1 $\frac{3}{4}$ in.	$\frac{1}{2}$ in.	5 in.	2 in.	1 $\frac{1}{4}$ in.



**25-INCH PEERLESS GEM CUTTER.**

Excels all other cutters of its size in weight, ease of cut, strength, durability and finish. It is built on the same design as the Peerless Gem in all points, except that the lever is fixed on the shaft instead of being adjustable. The weight is 825 pounds, unboxed; has  $4\frac{1}{2} \times \frac{3}{8}$ -inch knife;  $1\frac{1}{4}$ -inch knife bar. The best money's worth ever offered in a 25-inch paper cutter.

The leverage both while cutting and returning is perfect, reducing the exertion of cutting to a minimum.

The balance weight is hung inside the frame to save floor space.

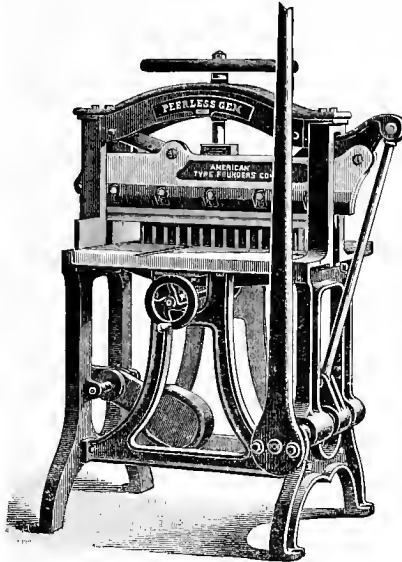

Style of 25-inch Peerless Gem Cutter.

25-inch, cuts  $25\frac{1}{4}$  inches

. . . . . \$125 00

**23-INCH PEERLESS GEM CUTTER.**

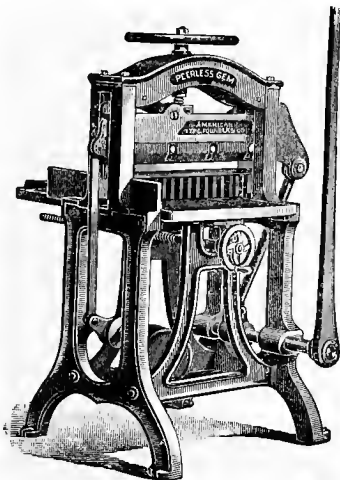

Style of 23-inch Peerless Gem Cutter.

No other cutter of this size, or about this size, equals the new 23-inch cutter. It weighs 725 pounds, unboxed; has  $4\frac{1}{2} \times \frac{3}{8}$ -inch knife, and  $1\frac{1}{4}$ -inch knife bar. Built on the Peerless-Gem principle, it has leverage of maximum power and easy return, and all the features of the 25-inch Peerless Gem Cutter. It is not possible to build a better cutter for the money asked.

The balance weight is hung inside the frame, thus saving floor space and removing an annoying obstruction.

23-inch, cuts  $23\frac{1}{4}$  inches

. . . . . \$100 00

**UTILITY PAPER CUTTER.**

A thoroughly well-built cutter, without a superior of its size. Has side and back gauges, and a patent reversible clamp which cuts very narrow strips without marking the paper.

Cuts and squares 16 inches  
Cuts and squares 18 inches

Without Stand.	With Iron Stand.
\$50 00	\$57 00
60 00	67 00

**EXTRA KNIVES.**

16-inch . \$4 50  
18-inch . 6 00

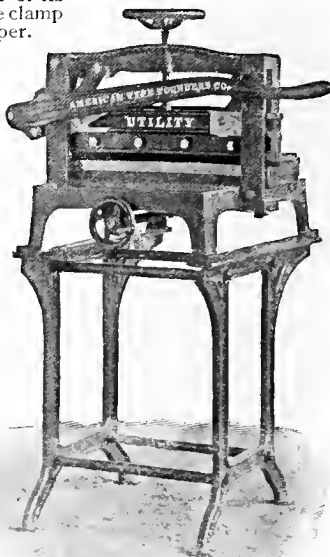

Utility Paper Cutter with Iron Stand.

**WITH IRON STAND.**

Iron stands are made for each size, and are recommended where bench room should be saved.

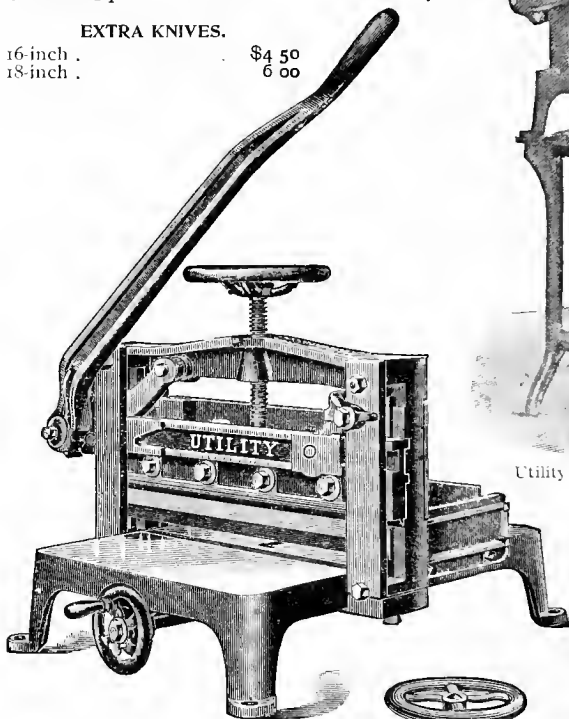

**CLIPPER PAPER CUTTER.**

Designed for cutting small work, such as labels, circulars, etc. Has a patented reversible clamp, which cuts very narrow strips and leaves no marks on the paper. The lever is pulled forward to cut. Quality of construction is A1.

Cuts and squares 12 inches . \$40 00

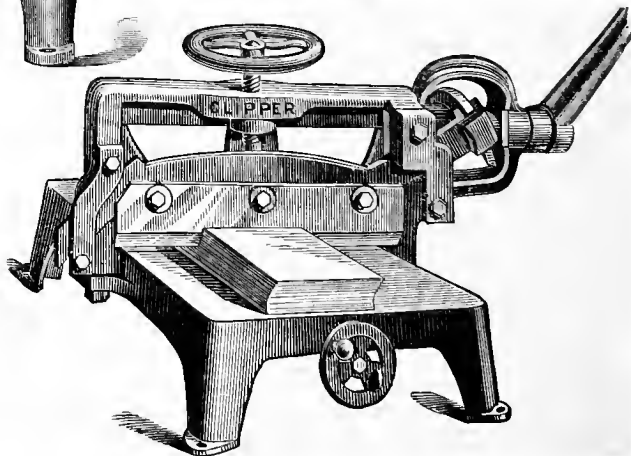

**CHANDLER & PRICE PAPER CUTTER.**

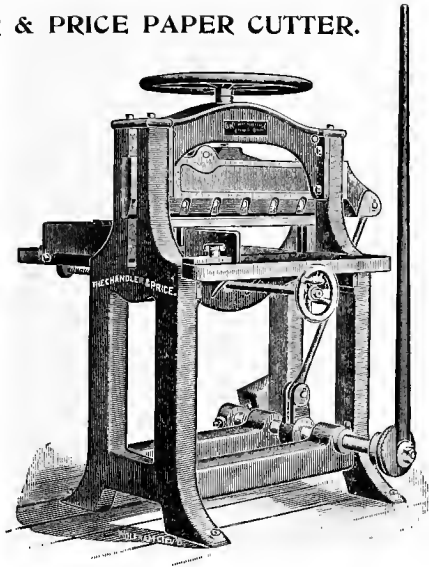

Of modern and strong construction, and built by one of the most reliable builders of printing machinery in the world. Has interlocking back gauge and clamp, and gauges to a half inch from the cutting edge of the knife. Has side gauges and adjustable lever.

23-inch . . . . .	\$100 00		26-inch . . . . .	\$130 00		30-inch . . . . .	\$175 00
-------------------	----------	--	-------------------	----------	--	-------------------	----------

**PEERLESS POWER PAPER CUTTER.**

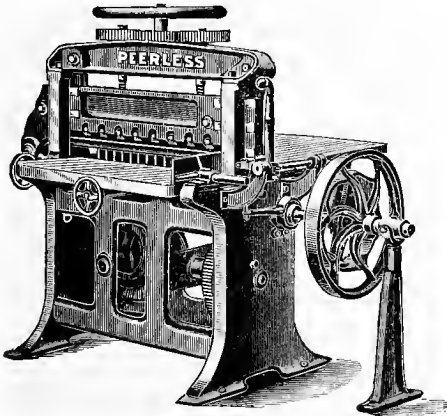

A powerful, compact, well-built cutter. The clamp is operated by two worm-screws, which give it great firmness. Has interlocking back gauges and clamp, side gauges and measuring gauge. All movements are positive; all adjustments easy and rapid.

Cuts 36 inches square . . . . .	\$650 00		Cuts 40 inches square . . . . .	\$800 00
---------------------------------	----------	--	---------------------------------	----------

ADVANCE POWER CUTTER.

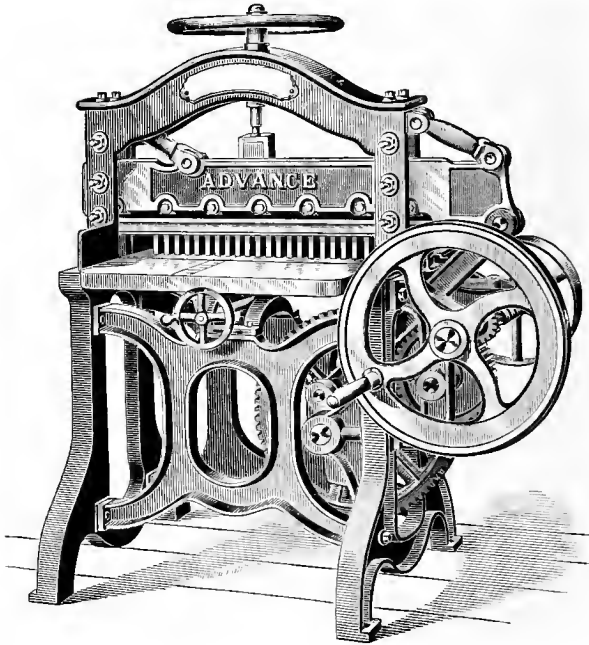

**This is the lowest-priced Power Paper Cutter on the market, and can be recommended to buyers with whom low price is a prime consideration.**

The Advance Power Cutter is fitted for hand or steam, is solidly built, the frame is firmly stayed by two substantial cross-braces, upon which is bolted the arch that supports the center of the bed, making it perfectly rigid and firm under pressure of clamp or knife.

It is fitted with the interlocking back gauge and clamp, by which paper may be cut to within half an inch of the knife.

It has brass figured rules in bed, back and front.

The throw-off is automatic and stops the knife instantly; it may be thrown off at any point, thus obviating possible waste of paper through error.

The knife has a dip-cut, which will be duly appreciated by all requiring a power paper cutter.

The slideways in which the knife bar moves is faced with steel gibs secured and adjusted by means of three set-screws on each side, so that any wear in the slideways may be taken up quite easily.

This is a very convenient style of cutter, as it will be found to be an effective and easily operated hand-power cutter at times when other power is not available.

30-inch, squares 30 inches . . . . .	\$300 00
33-inch, squares 33 inches . . . . .	350 00

DOOLEY PAPER CUTTERS.

Hand Clamp.

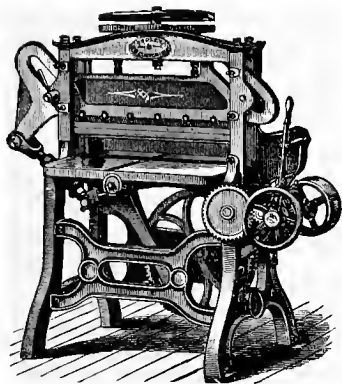

32-inch Power and Hand Wheel Dooley Cutter.

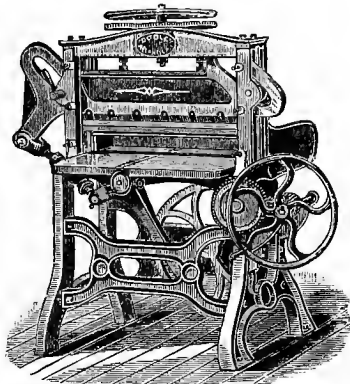

32-inch Hand Wheel Dooley Cutter.

These cutters are of superior merit, and are sold at moderate prices. They are very carefully made, and with the best materials. They have found favor with firms of national reputation, in whose establishments paper cutters are put to the severest tests. Among several hundred users the following names will be recognized by all printers and bookbinders :

L. PRANG & Co., Boston.  
 J. C. AYER Co., Lowell, Mass.  
 DENNISON MFG. Co., Boston.  
 JOHN A. LOWELL & Co., Boston.

MAST, CROWELL & KIRKPATRICK, Springfield, Ohio.  
 GOVERNMENT PRINTING OFFICE, Washington, D. C.

LIST PRICES.

32-inch Hand Wheel (see cut)	\$300 00
32-inch Power and Hand Wheel (see cut in which driving-wheel is not shown)	350 00
36-inch Hand Wheel (differs from 32-inch only in the clamping-wheel, which is upright instead of horizontal)	450 00
36-inch Power (differs from 32-inch, as stated above)	500 00
40-inch Power (very powerful; see cut)	750 00
48-inch Power (very powerful; see cut)	1000 00

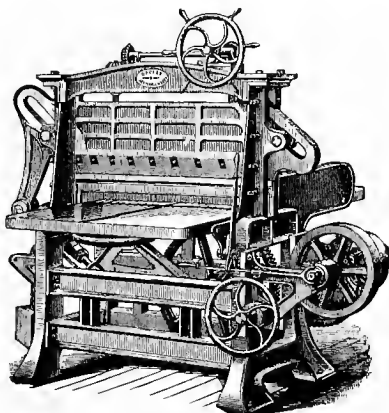

40-inch and 48-inch Power Dooley Cutter.

FEISTER-BROWN SELF-CLAMPING PAPER CUTTER.

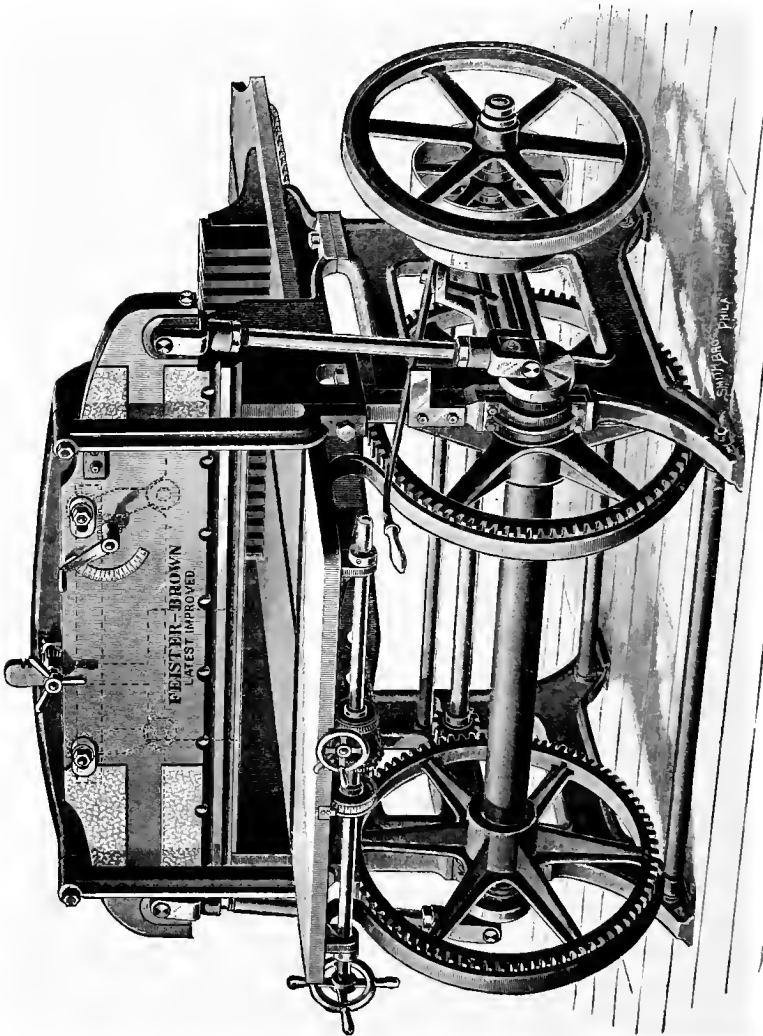

## FEISTER-BROWN SELF-CLAMPING PAPER CUTTER.

*See illustration on opposite page.*

The automatic clamp on this cutter is so constructed that it can be made, by the turn of a lever, to clamp hard or easy as the nature of the work may require. This clamp is actuated by a patent automatic parallel link motion that has only three working parts, which cannot get out of order. It will hold one sheet or five inches of paper with equal security. It is provided with an advance gauge which can be brought down to the work at will, in advance of the knife, and returned to its highest position whether the knife is moved or not.

The knife bar is actuated by a very strong shaft, fitted with cranks at both ends. These cranks have adjustable connecting rods attached to universal bearings on both ends of the knife bar and on the cranks (no awkward ball joints).

Motion is imparted to the crank shaft by twin gears and forged steel pinions, all placed inside of the machine frame, with the result that all strain of clamping and cutting is equally distributed over the whole machine frame (no oblique or twisting strains on the machine).

The machine is driven by one of the most complete friction clutches ever applied to a machine, which contains the fewest possible parts to be used to obtain the most durable and best results, and the machine can be run from twenty-five to thirty cuts per minute with ease and safety.

The whole upper portion of the machine frame, including table, side gauge, girder and top cross stay or arch, are cast in one solid, massive, rigid piece of iron. Not a bolt is used, therefore none can work loose, besides the machine has the advantage of being much truer and stronger than when bolted together in the old way.

The back gauge is made in two parts for printers' use and in three parts for book-binders' use, so that heads, tails and fronts of books can be trimmed without moving or changing it.

It is fitted with quick traverse movement, as well as hand-screw movement for "fine precision adjustment."

A measuring band, in convenient sight of the operator, indicates the sizes to be cut, both in front of the knife as well as between the back gauge and knife.

The back gauge is fitted with patent finger sections that slide so close on the table that the thinnest tissue cannot get under it. They also enter recesses in the clamp, so that the last of the stock can be cut up close to the knife. By this method there are no awkward grooves planed in the table to displace the under sheets, as used on some makes of machines.

This machine is a model of simplicity in construction. It contains but eight main moving parts. There is nothing about it to get out of order.

This cutter is the joint invention of Samuel Brown (inventor of the Brown & Carver Paper Cutter) and H. P. Feister (inventor of the Feister Perfecting Press and other well-known machines), and is the fruit of their very lengthy experience in constructing paper cutters.

### LIST PRICES F. O. B. FACTORY.

Size.	Diameter and Width of Face of Driving Pulley.	Revolutions per Minute of Driving Pulley.	Floor Space.	Weight when Boxed.	Price.
35 inches .	. 18×3 inches .	. 275 .	. 6 ×5½ feet .	. 3800 lbs.	\$600 00
39 inches . .	. 18×3 inches .	. 275 .	. 6½×6 feet .	. 4300 lbs.	725 00
45 inches .	. 18×3 inches . .	. 275 .	. 7 ×6½ feet .	. 4800 lbs.	910 00
51 inches .	. 22×4 inches .	. 220 .	. 7½×7 feet .	. 5700 lbs.	1225 00
59 inches .	. 22×4 inches .	. 220 .	. 8 ×7½ feet .	. 6100 lbs.	1550 00
66 inches . .	. 22×4 inches .	. 220 .	. 8½×8 feet .	. 6800 lbs.	1850 00

**CUTTING STICKS.**

	½ inch Square.	¾ to 1½ inch Square.	Round for Acme
30-inch and under, per dozen . . . . .	\$0 75	\$1 50	\$2 50
34-inch and under, per dozen . . . . .	0 80	1 60	2 50
38-inch and under, per dozen . . . . .	0 85	1 70	2 75
44-inch and under, per dozen . . . . .	0 95	1 85	3 00
48-inch and under, per dozen . . . . .	1 00	1 95	3 50
54-inch and under, per dozen . . . . .	1 10	2 10	4 00

**CUTTING STRIPS.**

For Hamilton's Patent Cutting Stick, described below.

Under 38 inches, per dozen, net . . . . .	\$0 25
38 inches and not exceeding 54 inches, per dozen, net . . . . .	0 40
55 inches and longer, per dozen, net . . . . .	0 50

**HAMILTON PATENT CUTTING STICK**

Consists of a main body piece (A), made to fit the groove of your paper cutter. The body piece has a groove or recess in it, which holds a small strip (B) one-quarter of an inch square. This removable strip is the cutting surface, and is held in place by a steel clamp (C), which is drawn up by the bolts (D). The cutting strips, being square, can be used on four sides, thus giving the same amount of service as the large-size sticks heretofore used.

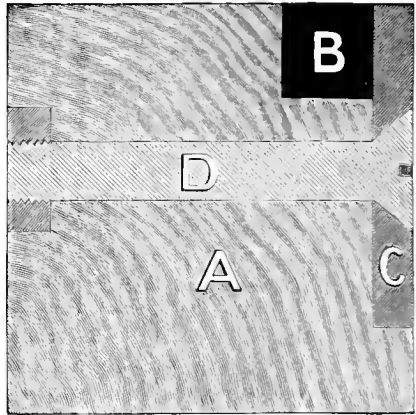

**SEE THAT B?**

- A** is the body piece made to fit groove in cutter.
- B** is the cutting strip on which knife strikes. It is one-fourth inch square, and is just as effective as if it was one and one-quarter inch square, also cheaper, and always fits.
- C** is the steel clamp which holds the cutting strip and prevents warping.
- D** is the screw which grips the clamp to the body piece.

**ADVANTAGES.**

1. The steel strip or clamp (C), running the extreme length of the main body piece, and firmly screwed thereto, effectively prevents springing and warping, which cannot be prevented on ordinary cutting sticks.
2. There is no wear on the body piece, and as it is fitted exactly to the groove of your cutter your troubles from ill-fitting sticks (necessitating packing, etc.) cease.
3. The cutting strips are all made to a uniform standard and are interchangeable, and thus there is an absolute certainty of them fitting.

**HOW TO ORDER.**

1. Give size square the main body piece is to be. Be particular on this point, and see that groove in cutter is accurately measured. 2. Give length of stick. 3. State how far from front edge of stick the knife strikes. 4. State whether knife cuts from right to left or left to right. In ordering cutting strips give the exact length required. All strips are cut to a standard uniform gauge, and are sure to fit.

Main body piece, under 38 inches long, net . . . . .	\$5 00
Main body piece, 38 inches to 54 inches long, net . . . . .	6 00
Main body piece, 55 inches long and over, net . . . . .	7 00
Cutting strips, under 38 inches long, per dozen, net . . . . .	0 25
Cutting strips, 38 inches to 54 inches long, per dozen, net . . . . .	0 40
Cutting strips, 55 inches and longer, per dozen, net . . . . .	0 50



**AUTOMATIC KNIFE GRINDERS.**

Knife grinders have become a necessity in large printing offices, as well as in offices remote from grinding establishments, as in the latter the saving not alone of the cost of grinding, but of expressage, delays, and extra knives will very soon pay for the cost of a knife grinder.

Two styles are made. In the light pattern, as illustrated on this page, the slide or knife holder is moved by hand against the emery wheel, which is turned by power.

The weight of the 32-inch size is 550 pounds, boxed. The tight and loose pulleys are six inches in diameter, and should run at 1100 revolutions per minute.

The grinder is adjustable for flat or concave grinding. The emery wheels are eight inches in diameter, with three and one-half inch face, and can be used up almost entirely. Extra wheels cost \$4.00 each, net.

In ordering light or heavy pattern grinders it is necessary to send accurate description of knives to be ground. Knife holders are made to suit any knife without extra charge.

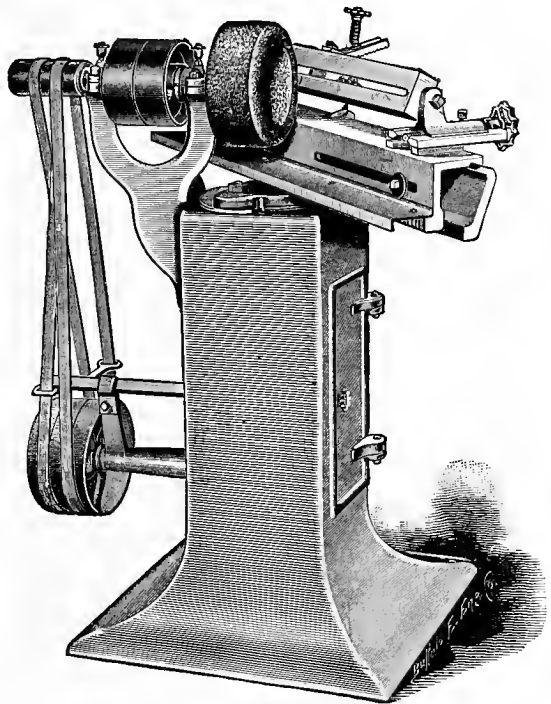

Style of Light Pattern Grinder.

**NET PRICES OF LIGHT PATTERN (STYLE B) GRINDERS.**

	Complete		Complete
Grinds knives up to 26 inches . . .	\$ 75 00	Grinds knives up to 54 inches . . .	\$130 00
Grinds knives up to 32 inches . . .	85 00	Grinds knives up to 60 inches . . .	140 00
Grinds knives up to 44 inches . . .	105 00	Attachments for water, extra . . .	10 00

**HEAVY PATTERN AUTOMATIC KNIFE GRINDER.**

In this style the knife holder is moved by power, and reverses automatically. The knife holder can be set at different angles from the emery wheel, which has a flat face with the corners rounded off. If the bed is set at a right angle to the emery-wheel spindle, the knife moves back and forth against the face and is ground a flat bevel; if it is set at any other angle the rounded corner will do the grinding and the bevel will be concave. This feature will be appreciated by those who prefer a flat, stout edge for rough work, and a thin, concave edge for fine work. The emery wheels are twelve inches in diameter with four-inch face, and can be used up almost entirely. Extra wheels cost \$7.00 each, net. The tight and loose pulleys are eight inches in diameter, and should run at 800 revolutions per minute. Weight of the 108-inch grinder is 1800 pounds. A perfect water attachment is supplied, the water being delivered in any desired quantity on the bevel of knife by means of a brass centrifugal pump.

**NET PRICES OF HEAVY PATTERN (STYLE A) GRINDERS.**

	Complete		Complete
Grinds knives up to 54 inches . . .	\$200 00	Grinds knives up to 90 inches . . .	\$280 00
Grinds knives up to 60 inches . . .	215 00	Grinds knives up to 96 inches . . .	310 00
Grinds knives up to 76 inches . . .	235 00	Grinds knives up to 108 inches . . .	350 00
Grinds knives up to 84 inches . . .	280 00		

## BOSTON CARD CUTTERS.

With Accurate Gauges.



No. 24. With 24½-inch blade.

These cutters have iron frames and polished hard-wood tables. The Nos. 12 and 24 sizes have accurate front, side and back gauges. The front gauge is operated by racks and pinions which hold the gauge securely at each end, and move it exactly parallel with the knife. No clamp is required, as the knives have a drawing cut, which keeps the sheet straight.

The No. 12 size will cut any length of sheet in two or more cuts, as the standard that holds the knife bar is on its inner side in line with the cutting edge, as shown in the cut. The No. 8 size has a reversible gauge, which may be used either at front or back.

- |                                   |        |
|-----------------------------------|--------|
| No. 8, with 8½-inch blade . . .   | \$8 50 |
| No. 12, with 12½-inch blade . . . | 12 00  |
| No. 24, with 24½-inch blade . . . | 24 00  |

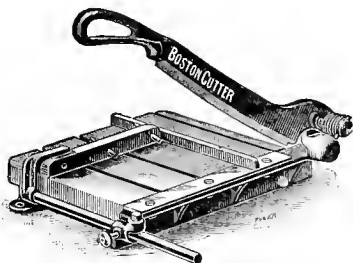

No. 8. With 8½-inch blade.

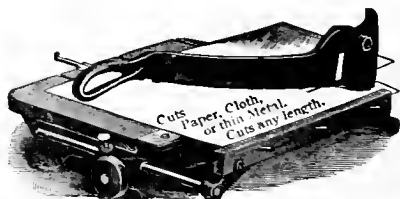

No. 12. With 12½-inch blade.

## SUCCESS CARD CUTTER.

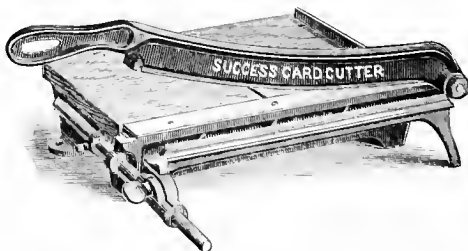

A well-made, reliable cutter, with movable side and front gauges. 12-inch knife . \$10 00



Missing Page

**MONITOR PAGING AND NUMBERING MACHINE.**

For Treadle or Steam Power.

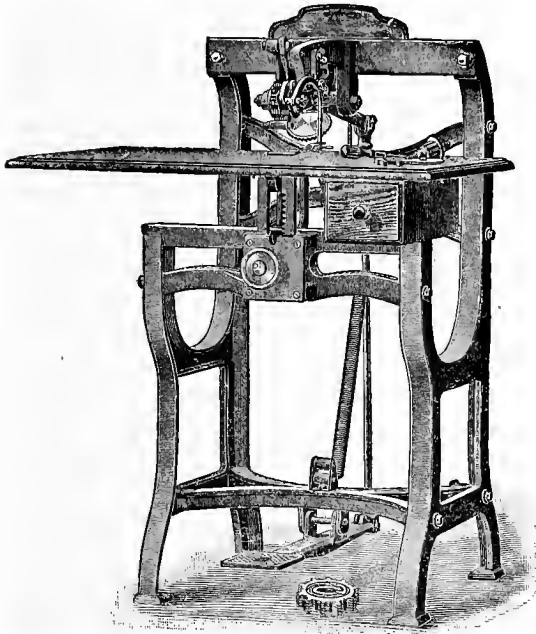

A reliable, well-constructed machine, with steel numbering heads, which by changing a single hand screw will number consecutively or alternately from 2 to 4 to 6, and so on, or from 1 to 3 to 5, and so on, or by the use of a repeating wheel fastened by a single hand screw will repeat a number any desired number of times. The table is adjustable up and down. The foot-power machines are made with journal boxes, so that power fixtures may be added at any time.

	For Power and Treadle.	For Treadle.
With one four-roll steel figure-head .	\$225 00	\$175 00
With one six-roll steel figure-head .	235 00	185 00
With one four-roll and one six-roll steel figure-head	285 00	235 00

Prices for machines for power include countershaft and hangers. If these are not required, the prices of power machines will be \$30 additional to prices of treadle machines.

**STEEL PAGING AND NUMBERING FIGURE-HEADS.**

Four-roll, to number 10,000 .	\$50 00
Five-roll, to number 100,000 .	60 00
Six-roll, to number 1,000,000 .	70 00
Extra repeater	3 00

Prices of numbering heads include one repeater. Styles of figures sent on application.

**No. 6 ACME  
TREADLE  
STAPLE BINDER.**

**The Only Staple Binder  
Which Will Not Clog.**

The No. 6 Acme Wire Staple Binder does a greater range of work, and does better work, than any other staple binder. At one stroke of the treadle it drives, clinches and releases the staple, each operation being independent, though continuous. It holds two hundred and fifty staples at a charge, and round or flat and fine or coarse staples may be used. Staples are fed automatically to driver by positive pressure on both legs, and clogging is prevented by a device which effectually prevents more than one staple getting under the driver at a time. The clinch is perfect on any thickness. There is ample room for putting in and taking out work, as the driver arm lifts more than an inch above the table after each clinch. There is a long space under the arm for calendar work. The treadle has a positive movement. Every machine is furnished with a strong iron stand. Will bind to a thickness of  $\frac{1}{4}$  inch through any kind of paper, and is furnished with both flat and saddle-back tables, with gauges on the flat bed. For hard or coated papers, when the work is heavy, flat wire staples are used.



Acme Staple Binder No. 6. For treadle, with flat and saddle tables.

**Price, \$40.00**

**PRICES OF ACME TREADLE STAPLE BINDERS.**

- No. 6 Acme Wire Staple Binder, capacity  $\frac{1}{4}$ -inch and under, on all kinds of paper, for round or flat wire, with table and treadle complete . . . . . \$40 00  
 No. 4 Acme Wire Staple Binder, capacity  $\frac{1}{4}$ -inch and under, on ordinary printing paper, for round fine wire only, with table and treadle complete . . . . . 27 00

**For Prices of Staples, see next page.**

**No. 4 ACME TREADLE STAPLE BINDERS.**

**The Only Staple Binders  
Which Will Not Clog.**

The No. 4 Acme is very similar in appearance to the No. 6, and will stitch the same thickness on ordinary paper, but it uses only round fine staples, which cannot be used successfully on coated or filled paper unless such work is light. This machine is specially adapted for stapling the average run of pamphlets, calendars, sample work, etc. It does both flat and saddle-back work. It has the device for prevention of clogging, and the clinching is done by the pressure of the blade while driving the staple. Holds two hundred and fifty staples at a charge.

**UTILITY OF THESE  
MACHINES.**

The addition of one of the Acme Treadle Staple Binders to the plant of small or moderate-sized printing offices, in towns in which there are no binderies, will make it easy and profitable to bind pamphlets, receipt books and other work. In towns where there are binderies they enable printers to save time, save handling of stock, and to avoid losses and damage in transit. All the staple binding machines in use were invented by one man, and the Acmes are the latest and most efficient. Like all such machines there is a certain knack to be acquired in order to handle them to the best advantage. Operators should read directions (which accompany the machines) very carefully.



Acme Staple Binder No. 4.

**Price, \$27.00**

**STAPLES FOR ACME BINDERS.**

For Acme Binder No. 6 : No. 21,  $\frac{1}{8}$ -inch round ; No. 22,  $\frac{1}{16}$ -inch round ; No. 23,  $\frac{1}{4}$ -inch flat ; No. 24,  $\frac{1}{16}$ -inch flat—per box of 5000 of one size . . . . . \$1 25  
 For No. 4 : No. 21,  $\frac{1}{8}$ -inch round, and No. 22,  $\frac{1}{16}$ -inch round—per box of 5000 of one size . . . . . 1 25

**ACME  
STAPLE BINDER  
No. 1.**



The most satisfactory low-priced staple binder made. *It will not clog*, as only one staple can get under the driver at one time. The frame swings on a pivot, and lifts high enough to give ample room for putting in and taking out the work—an advantage not obtainable on other low-priced staple binders. It holds one hundred staples at a charge. Binds  $\frac{1}{4}$ -inch and under. The staple is fed automatically under the driver, which descends and drives it through the paper, the pressure clinching the staple tight on the under side. Uses flat staples only.

Price . . . . . \$6 00  
Staples: No. 23A,  $\frac{1}{4}$ -inch, flat; No. 24A,  $\frac{1}{16}$ -inch, flat—per box of 5000 of one size . . . . . 1 25

**SURE SHOT  
STAPLE  
BINDER  
No. 1.**

The most reliable binder for office use. Holds one hundred staples at a charge. Works on the same principle as the Acme No. 1, described above, but has no lever. Binds from two to fifty sheets.



Price . . . . . \$3 00  
Staples: No. 23A,  $\frac{1}{4}$ -inch; No. 24A,  $\frac{1}{16}$ -inch—per box of 5000 of one size . . . . . 1 25



## BREECH LOADER STAPLE BINDER.

This is a handy machine for office use. Can be put to a great variety of uses. Binds paper or pamphlets from two to fifty sheets with wire staples; holds one hundred staples at a charge; feeds them out automatically; inserts them into the work, and clinches them on the under side.

Price . . . . . \$3 00  
 Staples: C,  $\frac{3}{16}$ -inch; D,  $\frac{1}{4}$ -inch; E,  $\frac{5}{16}$ -inch—per box of 1000 . . . . . 0 50

*Only one size of staples in a box.*



## HERCULES WIRE STAPLE BINDER.

For Hand or Treadle.

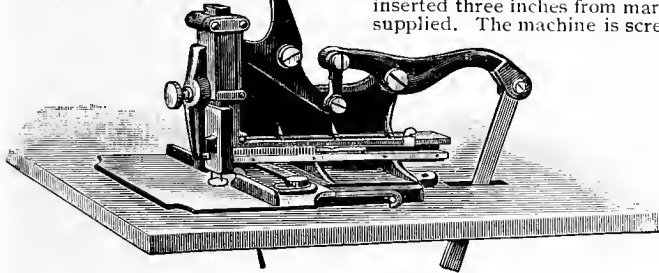

The cheapest treadle staple binder. Binds paper to thickness of  $\frac{1}{4}$ -inch. Staples can be inserted three inches from margin. No table is supplied. The machine is screwed on a bench, and the treadle is screwed to the floor, connecting by means of a rod and spring.

Sold also for hand power only. Only one size of staples in a box.

Price, with treadle . . . . . \$10 00  
 Staples: F,  $\frac{3}{16}$ -in.; G,  $\frac{1}{4}$ -in.; H,  $\frac{5}{16}$ -in.; K,  $\frac{3}{8}$ -in.—per box of 5000 of one size . . . . . 1 25

## OTHER STAPLE BINDERS.

No. 9 Staple Binder binds paper  $\frac{1}{4}$ -inch thick, complete with table and treadle . . . \$36 00  
 No. 8 Saddle Back Staple Binder takes  $\frac{3}{16}$ -inch staples only; designed for saddle-back work, but will take flat work by adding flat table; with saddle back only, \$30 00; with flat and saddle-back tables . . . . . 31 50  
 Lightning Staple Binder No. 1 staples through  $\frac{1}{4}$ -inch paper; No. 2 staples through  $\frac{5}{16}$ -inch paper; each complete with treadle . . . . . 24 00

## WIRE STAPLES.

The prices for staples for the wire staple binders illustrated on this and preceding pages are given under the description of each binder. The following are the prices of staples for the binders not illustrated:

For No. 9 Staple Binder: Staples No. 1  $\frac{1}{2}$ ,  $\frac{3}{16}$ -inch long; No. 2,  $\frac{1}{4}$ -inch long; No. 3,  $\frac{5}{16}$ -inch long—per box of 5000 of one size . . . . . \$1 25  
 For No. 8 Saddle Back Staple Binder: Staples No. 1,  $\frac{3}{16}$ -inch long—per box of 5000 . . . . . 1 25  
 For Lightning Staple Binder No. 1: Staples No. 7,  $\frac{3}{16}$ -inch long; No. 8,  $\frac{1}{4}$ -inch long; No. 9,  $\frac{5}{16}$ -inch long—per box of 5000 of one size . . . . . 1 25  
 For Lightning Staple Binder No. 2: Staples No. 10,  $\frac{3}{8}$ -inch long; No. 11,  $\frac{7}{16}$ -inch long; No. 12,  $\frac{1}{2}$ -inch long—per box of 5000 of one size . . . . . 1 25

PERFECTION WIRE STITCHERS.

Perfection Stitchers, as shown on this and following pages, have for a number of years given invariable satisfaction with a minimum of trouble. They are exceedingly well made and strong. The adjustment from one length of staple to another is accomplished by changing a pin from one hole on dial plate to another.

These stitchers take wire from spools and make staples from round or flat wire of any desired length within the capacity of each machine. There are over 10,000 staples of the length used on an ordinary pamphlet in one pound of No. 25 wire.

PERFECTION "G"  
WIRE STITCHER.

Steam Power or Treadle.

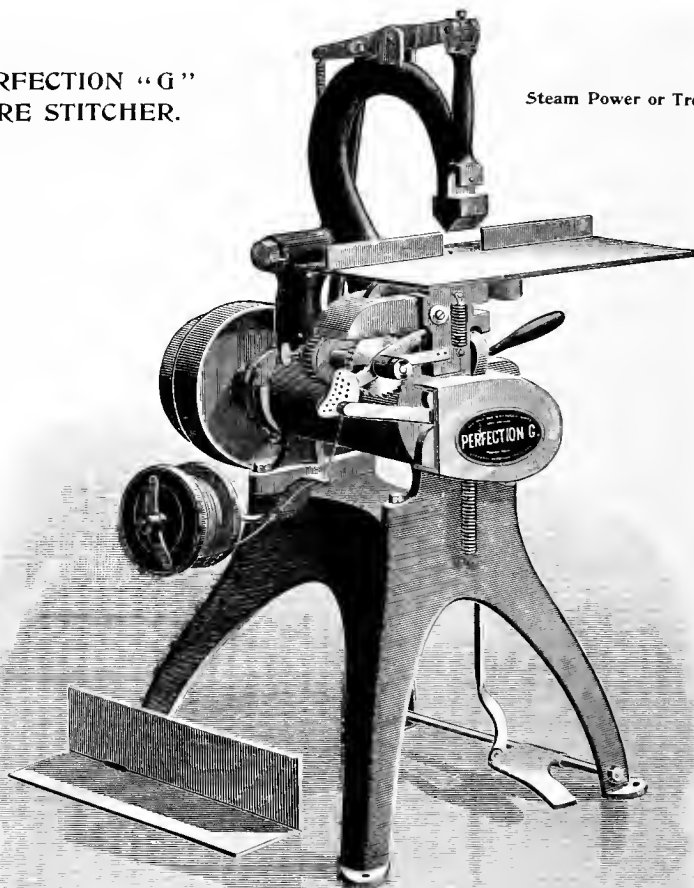

Capacity, two sheets to almost  $\frac{7}{8}$ -inch. Large trough and flat table. Uses 20 to 28 gauge wire.

Perfection "G," for steam or treadle power . . . . . \$250 00

*For Prices of Wire, see Price List of Wire.*

THE BEST OF EVERYTHING FOR THE PRINTER

## PERFECTION "C" WIRE STITCHER.

For Steam Power Only.

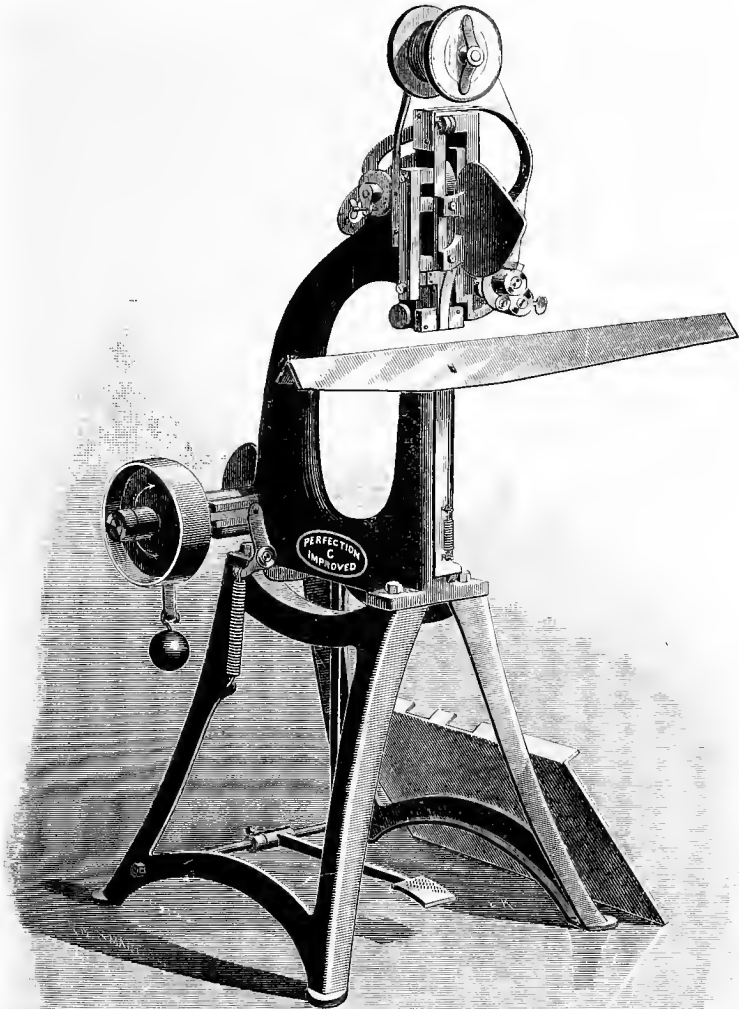

Specially adapted for pamphlet binding, stitching calendars, and all work up to one-fifth inch. Extra long saddle and flat table. Takes 23 to 30 gauge wire.

Perfection "C" Wire Stitcher, for steam power only

. \$150 00

*For Prices of Wire, see Price List of Wire.*

AMERICAN TYPE FOUNDERS COMPANY

PERFECTION "A" WIRE STITCHER.

Hand or Foot Power.

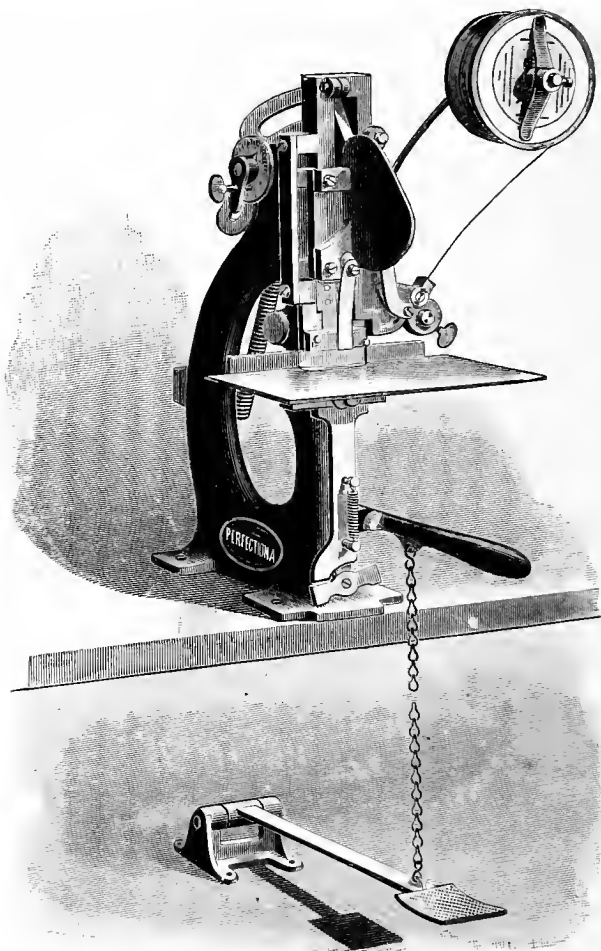

The cheapest satisfactory stitcher of this class now on the market. It is adapted for work varying from two sheets to one-fifth inch in thickness. May be used with flat table or saddle, with wire of from 23 to 30 gauge. The saddle is extra long.

Perfection "A," for hand or foot power

.. \$90 00

*For Prices of Wire, see Price List of Wire.*

**No. 7  
NEW  
PERFECTION  
WIRE  
STITCHER.**

This machine has all modern improvements. It sets automatically for all thicknesses of work. The patent table is changeable from flat to saddle, or vice-versa, without removal. There is an extra length of space between clinchers and frame to accommodate large calendars and extra large publications. Constructed expressly to stitch heavy work with light wire, without change of parts, although heavy wire can be used if desired. Has the roller-feed device in its latest improved form, and patent supporting and clinching devices which are unexcelled.

Will stitch from one sheet to ¾-inch, and will run wire as fine as No. 25.

Price, complete . . \$300 00



**PRICE LIST OF WIRE.**

SUBJECT TO CHANGE WITHOUT NOTICE. DISCOUNT ON QUANTITIES.

The success of every wire stitching machine depends largely on the quality of the wire used. This wire is the best procurable. A spool holds five pounds of wire. No. 25 is sold per spool at twenty-five cents per pound. Wires Nos. 10 s, 30 s and 60 s, are for Thompson machines only.

Gauges of Wire.		100-Pound Lots.	500-Pound Lots.	1000-Pound Lots.
Round: Nos. 18 and 19	per lb.	\$0 10	\$0 09	\$0 08½
Nos. 20, 21, 22 . . . . .	per lb.	0 11	0 10	0 09
Nos. 23, 24, 25, or 30 s.	per lb.	0 12½	0 11	0 10
Nos. 26, 27, 28	per lb.	0 15	0 14	0 12½
No. 30 . . . . .	per lb.	0 18	0 17	0 16
Flat: Nos. 19×21, 19×21½, or 10 s. .	per lb.	0 16	0 15	
Nos. 20×23 and 20×25	per lb.	0 17	0 16	
Nos. 21×25 or 60 s. . . . .	per lb.	0 18	0 17	
Nos. 24×29 . . . . .	per lb.	0 19	0 18	

Spools are ten cents extra each, returnable less transportation charges. A case contains 100 pounds (20 spools).

**MONITOR AUTOMATIC WIRE STITCHER.**

These stitchers do a range of work from two sheets to work 1 3/8-inch thick.

**ADJUSTMENTS.**

There are only two adjustments: 1. The quantity of paper to be stitched is put in the thickness gauge, and the hand wheel at left of gauge is turned until the jaws clamp the paper tight. 2. Turn the hand wheel at right of machine to obtain proper length of staple, then turn the thumb-screw on the feed lever at the left to the same point on the scale.

**WIRE STRAIGHTENER.**

A patent wire straightener is attached to the combination slide, and by moving the lever in the direction the wire is desired to go it will respond invariably.

**ACCESSIBILITY.**

All the working parts are in plain view under a glass-faced front. By lifting the glass front you reach the parts. There is a swinging table which is a great convenience for some classes of work, and can be removed instantly if desired.

**WIRE USED.**

No. 0 uses flat wire, 19x21 1/2, only; No. 3 uses Nos. 25 and 27 round wire, unless specially ordered for flat wire, when it takes Nos. 20x25 flat and 25 round; all other Monitor Stitchers use No. 25 round and No. 20x25 flat wires.

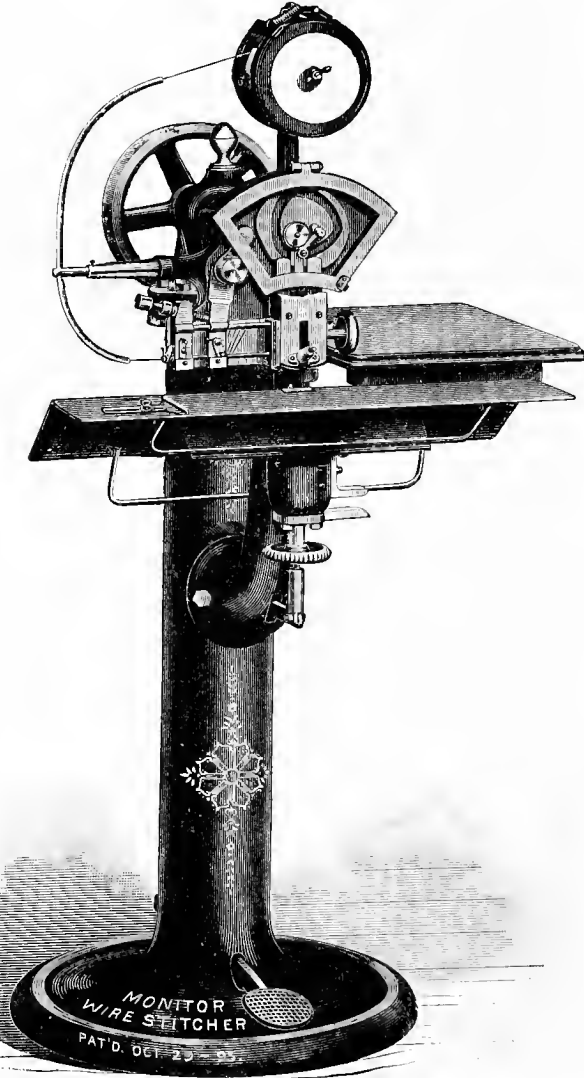

Style of No. 1 Monitor Wire Stitcher.

- No. 0, complete, capacity 1/4 to 1 3/8 inches
- No. 1, complete, capacity 2 sheets to 3/4-inch
- No. 1 1/2, complete, capacity 2 sheets to 1/2-inch
- No. 2, complete, capacity 2 sheets to 3/8-inch
- No. 3, complete, capacity 2 sheets to 1/4-inch

\$550 00
400 00
300 00
200 00
150 00

**TENNIS BOOK-SEWING MACHINE.**

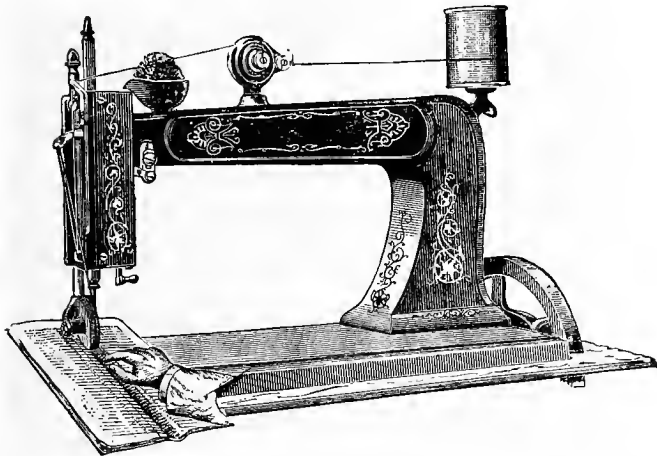

Designed for stitching blank books of every kind, and pamphlets and books not exceeding a thickness of three-eighths inch. Will sew through back or centre, making stitches one-inch, half-inch, or quarter-inch long. Books sewed by this method are durable, and open perfectly. Sample work sent to us will be stitched and returned.

This machine is in use in almost every prominent blank-book factory in the United States.

In ordering steam power it is necessary to state diameter of shaft from which belt will be run to machine.

**Shows Long Stitch.**



**Shows Short Stitch.**



**Shows Medium Stitch.**



For foot power, with stand and table . . . . \$60 00

For steam power, with variable speed, stand and pulleys, complete . . . . 70 00

Prices are strictly net f. o. b. factory.

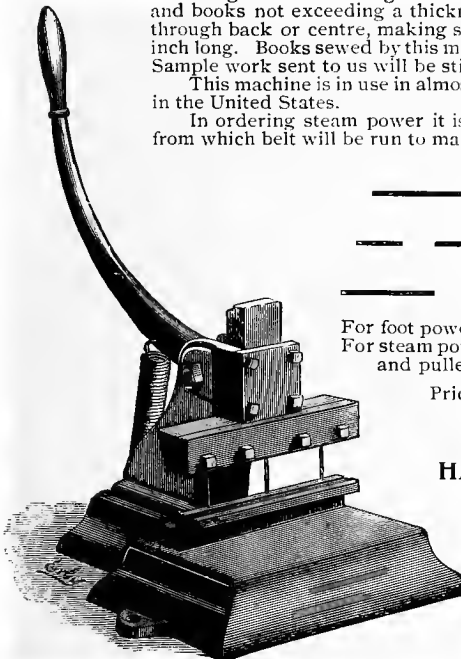

**HAND STABBING MACHINE.**

For stabbing pamphlets, receipt books, etc., by hand or foot power. Built of iron, and made to fasten to a bench or table. The position of the needles can be easily and quickly changed, as they move laterally in a slot, and are held by set screws.

For hand power . . . . .	\$25 00
For foot power . . . . .	50 00
Needles, per dozen . . . . .	3 00

UNION TABLETING APPARATUS.

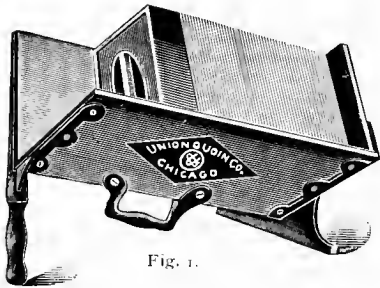

Fig. 1.

In this apparatus paper is held for padding without the use of screws or clamps. The trough (Fig. 1) is V-shaped, and is held at an angle which holds the paper snugly against the sides and the iron base-plate, which forms the bottom of the trough when it is tilted up. The paper in the trough is held under pressure by a heavy iron weight or brick; the trough is tilted up, and is lifted away, leaving the iron base-plate, paper and iron brick as in Fig. 2. The advantage this method has over the

table presses using clamps is that, by buying extra base-plates and iron bricks, an unlimited number of piles of paper may be put up without waiting for the drying of the cement; thus the capacity of this apparatus surpasses that of other apparatus used for a like purpose, and is equally as well adapted for use in both large and small establishments.

- Complete, with trough, base-plate and hollow iron brick, size 8½×8½×18 inches; capacity, 6000 sheets . . . \$7 50
- Extra iron bricks, hollow, each . . . 2 00
- Extra iron bricks, solid, each . . . 3 00
- Extra iron base-plates, each . . . 0 75

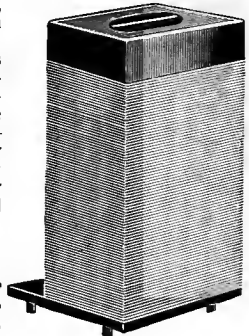
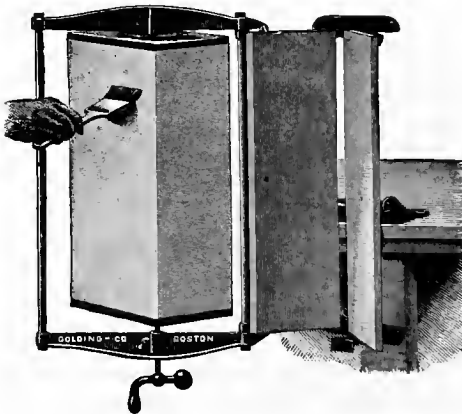
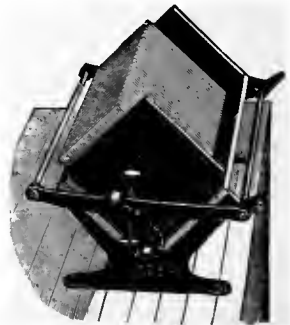

Fig. 2.



No. 2 Golding Tablet Press filled with paper and cement being applied, in a perpendicular position.

GOLDING TABLET PRESS.



No. 1 Tablet Press on bench, filled with paper.

The paper is put in the V-shaped trough between boards, and, after sufficient pressure has been applied by the screw in the end of a hinged clamping frame, the latter is swung over, exposing the underside of the paper for cementing. Pads from 2×2 inches up to full capacity of the press may be blocked. The No. 2 press has a hinged bracket by which it is screwed to a bench, and which permits the paper to be held in a perpendicular position after clamping.

- No. 1, will hold 2000 sheets, any size up to 6×12 inches . . . . . \$6 00
- No. 2, will hold 5000 sheets, any size up to 8×16 inches . . . . . 12 00



## BINGHAM & RUNGE LIQUID PADDING GLUE.

Made in Red, Purple, Green and Colorless.

The Bingham & Runge Padding Glue was the first put on the market, and it has always maintained its reputation. The best materials are used in its composition, and on this account it does not get rancid. A quart will cement about 100,000 sheets of note size.

Half-Pints . . . . .	\$0 35	Quarts . . . . .	\$1 00
Pints . . . . .	0 60	Gallons . . . . .	3 75

### LIQUID CEMENT BRUSH.

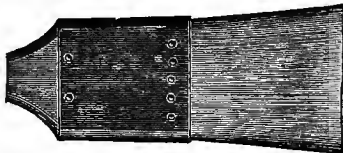

Made of French bristles, flat and double thick.

1 inch . . . . .	\$0 30	2 inch . . . . .	\$0 55
1 1/2 inch . . . . .	0 40	3 1/2 inch . . . . .	0 75



## BINGHAM & RUNGE HERCULES ELASTIC PADDING GLUE.

An elastic, tough, quick-drying preparation, which is applied hot after melting in an ordinary glue pot, and, while entailing more labor, gives better results than the liquid glue. Does not adhere to the edges of sheets as they are removed from the pad, thus preventing tearing of pages in invoice and letter copying books. The color is bright red. Put up in pails, with directions for use on each.

5 pounds in pails . . \$1 50 | 10 pounds in pails . . \$3 00



### GLUE POT.



1 quart, each . . . . .	\$0 30
2 quarts, each . . . . .	1 20

### PAPER COUNTER.



This cut one-fourth actual size.

To make ready for use in pad work, count out number of sheets wanted by hand, on top of which place the plate, then draw the stab up firmly against the paper. The screw in handle holds the stab in place. To operate, place plate on top of lot to be counted and push stab into paper, bearing down at same time.

Price . . . . . \$0 75

### TABLET KNIFE.



Made specially for separating pads; extra thin and strong.

Price . . . . . \$0 50

**BOOKBINDERS' LETTERING PALLET.**

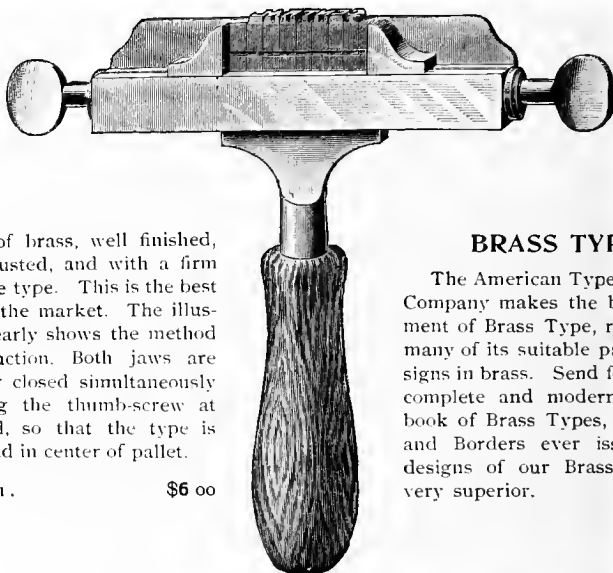

Made of brass, well finished, easily adjusted, and with a firm grip on the type. This is the best Pallet on the market. The illustration clearly shows the method of construction. Both jaws are opened or closed simultaneously by turning the thumb-screw at either end, so that the type is always held in center of pallet.

Price, each . . . . . \$6 00

**BRASS TYPE.**

The American Type Founders Company makes the best assortment of Brass Type, reproducing many of its suitable patented designs in brass. Send for the most complete and modern specimen book of Brass Types, **Ornaments** and **Borders** ever issued. The designs of our Brass Type are very superior.

**METAL TYPE FOR BOOKBINDERS.**

The Copper Alloy Type made by the American Type Founders' Company is of extra hardness, and better suited for bookbinding purposes than type made of ordinary type metal. All the type shown in the specimen books of the American Type Founders' Company is made of its famous Copper Alloy Metal.

**BOOKBINDERS' CABINETS.**

Made of hard wood, cherry finish, with bronzed pulls on each case. The cases are made in exactly the same style as printers' cases. These cabinets occupy a space of 20x20 inches, and may be put on or under a bench. "A place for everything and everything in its place" is a rule bookbinders should live up to, and these cabinets enable them to do so.

- Cabinets with 6 cases . . \$ 8 00
- Cabinets with 10 cases . . 12 00
- Cabinets with 15 cases . . 16 50

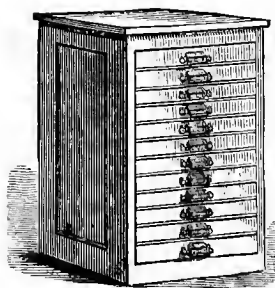

**BOOKBINDERS' CASE.**

- Half Cap Case, 16x16 1/4 inches, without bronze pull, each . . . . . \$0 60



Case used in Bookbinders' Cabinet.

**No. 4 PUNCHING AND HAND EYELETTING MACHINE.**

Nos.

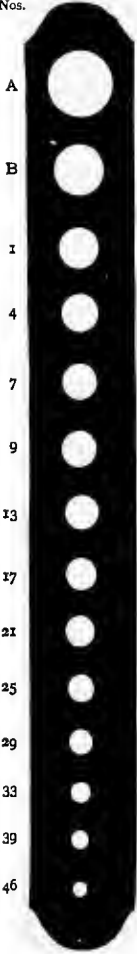

Can be used for Eyeletting by Hand by  
Substituting Punches for Eyelet Sets.



Punch and Die.

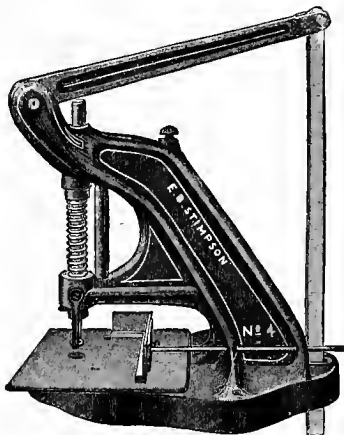

This is the proper machine to use with eyeletting machines shown on following pages. Except on cloth, good work cannot be done unless the hole is punched out *clean* before eyeletting. The No. 4 Machine will do work up to  $\frac{3}{8}$ -inch diameter (No. 3 Calendar Eyelet) and has a reach of  $6\frac{1}{2}$  inches back of plunger, and an adjustable gauge for all kinds of work.

By removing the punch and die and substituting an eyelet set, this machine may be used for eyeletting by hand feed, and will do perfect work.

No. 4 Punching Machine, with Treadle, and one Punch and Die	\$20 00
Extra Punch and Die, per pair .	2 50
Eyelet Set, per pair	2 50

**COMBINED EYELET PUNCH AND SET.**

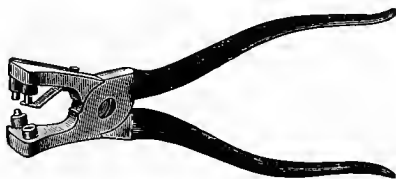

An indispensable tool in the printing office. Punches the hole and sets the eyelet. Takes only one size of eyelet (No. 2 Skirt).

Price, complete . . . . .	\$25
Eyelets, per box of 1000	. 0 50

Sizes of punches and dies correspond with eyelets made. Order by number.

**SELF-FEED FOOT POWER EYELETING MACHINES.**

With Removable Roadways.

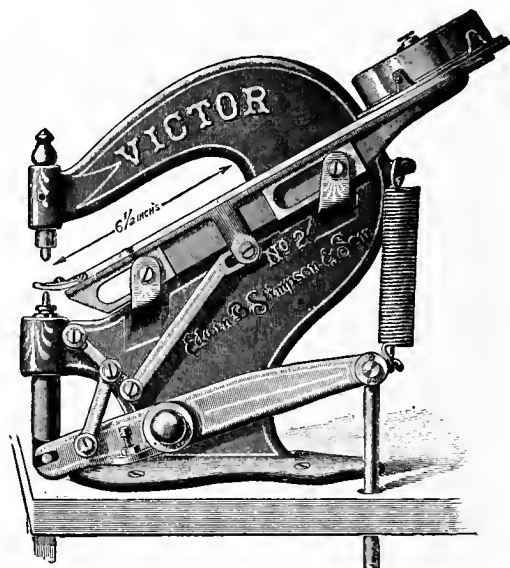

**THE VICTOR.**

Has a reach from eyelet set to back of arm of 6½ inches, and will set an eyelet in the centre of a square 13×13 inches. Will set eyelets in paper, metal, leather, cloth, etc.

The eyelet roadway or feed channel is made to feed but one size eyelet; if other size eyelets are used on machine, an extra roadway is necessary. When ordering machine, specify by name the eyelet for which machine is to be fitted. If extra roadways are wanted, be particular to state the size of eyelet to be used. It takes only a few moments to change one roadway for another on machine.

The Victor is easy to operate, weighs 30 pounds, is 14 inches high, 15 inches deep, and is a perfect working machine and very durable.

No. 2. The Victor, with one roadway	\$40 00
Extra roadways, each . . .	14 00
Power attachments, extra	40 00

In ordering, send samples of eyelets to be used, as the roadway will feed only one size of eyelet. An extra roadway is required for each size of eyelet.

**THE ROYAL.**

Differs from the No. 2 Victor in the reach only, which is 9 inches, setting eyelets in a square 18×18 inches.

It weighs 45 pounds, is 15 inches high, 16 inches deep, and is a perfect working and very durable machine.

No. 3. The Royal, with one roadway . . . . .	\$45 00
Extra roadways, each . . . . .	16 00
Power attachments, extra . . . . .	40 00

In ordering, send sample of eyelet to be used, as the roadway will feed only one size of eyelet. An extra roadway is required for each size of eyelet.

THE PETIT FOOT-POWER EYELETTING MACHINE.

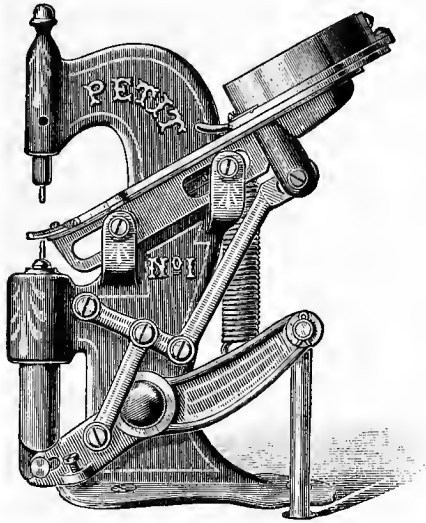

This is not recommended for the general work of printing offices and binderies, but is perfectly adapted to special work requiring eyelets not exceeding  $\frac{3}{32}$ -inch inside, known as No. 1 "C. Z." It will take the smallest eyelet,  $\frac{1}{16}$ -inch inside, known as "D. E." It is a perfect feeding machine, 12 inches high, 9 inches deep, weighs only 17 pounds, and is very easy to operate.

No. 1. The Petit, with one Roadway . . . . . \$30 00  
 Extra Roadways, each . . . . . 12 00

EYELETS.

The largest eyelet used is "No. 3 Calendar," smallest is "D. E.,"  $\frac{1}{16}$ -inch inside. The eyelets in most common use are "No. 3 Calendar" and "No. 2 Skirt" (as illustrated). The prices of eyelets in large quantities vary from time to time, and special quotations will be given when required.

Smallest quantity sold 10,000 in one box, except No. 3 Calendar, which are put up in boxes of 5000. They are also packed in bulk cases containing 250,000 of any size.

No. 3 Calendar Eyelets per box of 5000 . . . . . \$3 75  
 No. 2 Skirt Eyelets, per box of 10,000 . . . . . 4 50

Special quotations for larger quantities.

Sizes of Eyelets.

The cuts show exact sizes of each eyelet when set in the material eye-letted.

The heavy figures under cuts indicate the size of punch and die to be used with eye-lets.

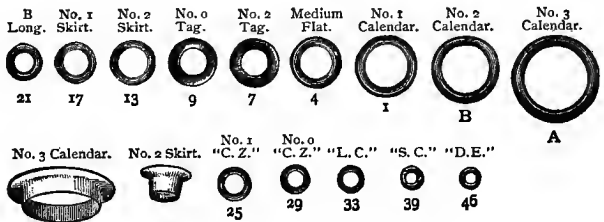

**HAND EMBOSsing PRESS.**

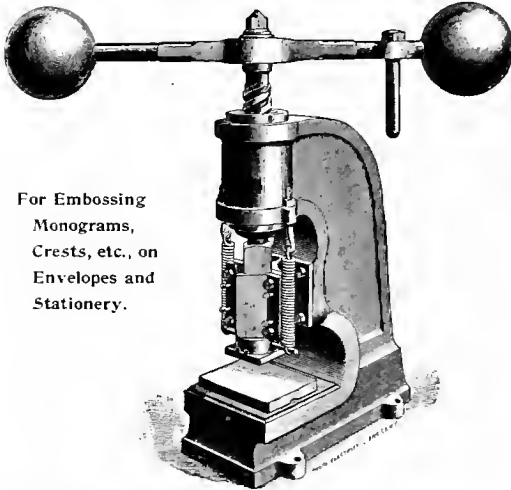

For Embossing  
Monograms,  
Crests, etc., on  
Envelopes and  
Stationery.

Embossed work on envelopes, note paper, menus, and other fine stationery, is the most stylish form of printing. The process is simple. Dies cost from \$1.00 to \$5.00, according to elaboration of design. Dies are made of steel. The counter is usually made of bristol board, thin rubber cloth and thin paper, and is fastened to bed-plate with glue or gum arabic. The inks are made from dry colors, mixed with white damar varnish. The ink is smeared over the die, and the face of the die is cleaned of ink, and polished by rubbing on paper. Bronzed effects are obtained by embossing with varnish instead of ink, and dusting on the bronze; superfluous bronze is taken off by dusting with a brush. Any printer can do this work, and thus add a lucrative department to the business.

This press is the best made, and is used by all the leading houses.

- Large Press, with one Die-Box and Counter . . . . .
- Small Press, with one Die-Box and Counter . . . . .
- Extra Die-Boxes, each . . . . .
- Extra Counters, each . . . . .

**\$75 00**  
**60 00**  
**4 00**  
**3 00**

Weight of large press is 335 lbs.; of small press, 190 lbs. Boxing, \$1.50, net.

Those who have use for one press are advised to purchase the large size, as the other will only take small dies. Largest die taken on large press, 5 x 4 inches; on small press, 4 x 3 inches.

**FAST GOLD LEAF LETTERING AND STAMPING PRESSES.**

Made in two styles. No. 1, illustrated here, is the best press of its kind for small stamping or embossing. Size of platen, 12 x 12 inches; size of head, 11 x 11 inches. The wheel at top carries the screw that raises or lowers the head, and the set screw at front binds it firmly. Can be supplied with 19/4 or 26 inches between uprights.

Three stamp-holders, varying sizes; one large chase, one large and one small plate for electros and brass work, one atmospheric gas heater, set of band holders, and assortment of steel fillers for chase, go with each machine.

The No. 2 press, for gas, gasoline or steam, is especially recommended for printing badges. In this press the bed does not slide, and the platen is raised or lowered by screws set in the side frames. Size of head, 12 x 12 inches; size of platen, 13 1/2 x 13 1/2 inches. Takes work 14 inches wide and any length.

The head will allow a change of six inches in thickness. One type-holder with chase, two plates for electros, one set of fillers, and an atmospheric gas heater go with each machine.

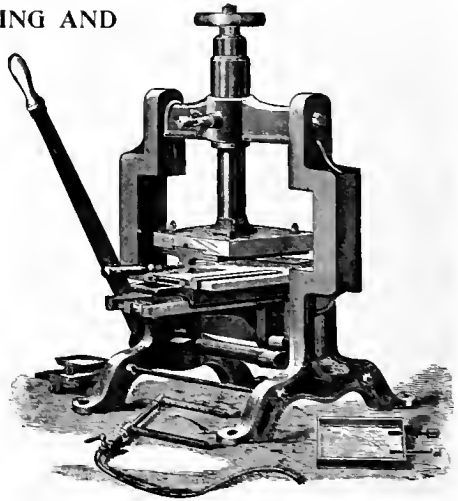

No. 1 Stamping and Embossing Press, for Steam, Gas or Gasoline.

No. 1, complete, as described . **\$150 00** | No. 2, complete, as described . **\$75 00**

Catalogue of Embossing Dies sent on receipt of 25 cents.

## CARVER & SWIFT POWER STAMPING PRESS.

Prints and Embosses at One Impression.

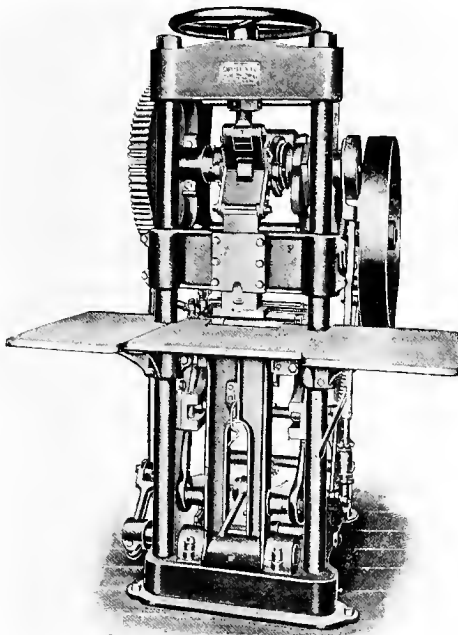

The die is held in a double-jawed chuck on bed of press ; immediately over the bed in its vertical position is a counter-block, driven up and down by connection with a powerful toggle. The counter is made in the same way as on the hand-stamping press, described on the next page. The ink fountain is at rear of press, having a continuously revolving roller which serves to keep the ink "alive." An oscillating arm carries the distributor, which supplies ink to the die on its backward and forward motion. As the die travels forward, it passes under the wiping plate, around which a web of manilla wiping paper is carried. The contact with the wiping paper removes all ink from the surface of the die, leaving it only in the engraved parts. The bed travels to a vertical position, where it is automatically locked and held for the impression. The sheets are fed to gauge pins as on a job press, and thus at one feeding the most beautiful results are produced.

Perfect register is insured for burnishing bronzed work by the fact that the machine is provided with an automatic lock, which holds the bed in position while the impression is made.

Any properly engraved die from one line, or monogram, up to commercial dies measuring three and one-half inches by eight inches, can be successfully stamped.

The speed is a matter most generally determined by the operator, and while a general average would be about nine thousand impressions per day, the machine has a record of seventeen thousand in less than eleven hours.

The machine weighs about four thousand pounds and occupies a floor space of three feet nine inches by four feet six inches, exclusive of projecting feed boards.

Stamping press, complete, with countershaft and hangers with friction clutch, wide-face pulley, and three-step cone pulley, three-step cone pulley for main shaft, two large and two small ink fountains, three counterblocks, one set each of push and composition rollers, f. o. b. factory . . . \$1650 00

FRANKLIN HAND PERFORATOR.

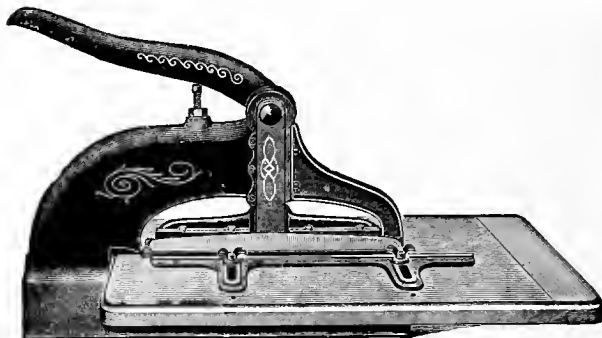

Perforates ten inches, and is provided with gauges on both sides, so that the sheets may be turned and fed in again, making a continuous perforated line of twenty inches. The pins make round holes, like the perforations on a sheet of postage stamps. Fifteen holes to an inch.

Hand Perforator, 10 inches

\$25 00

STIMPSON LEVER AND TREADLE ROUND-HOLE PERFORATOR.

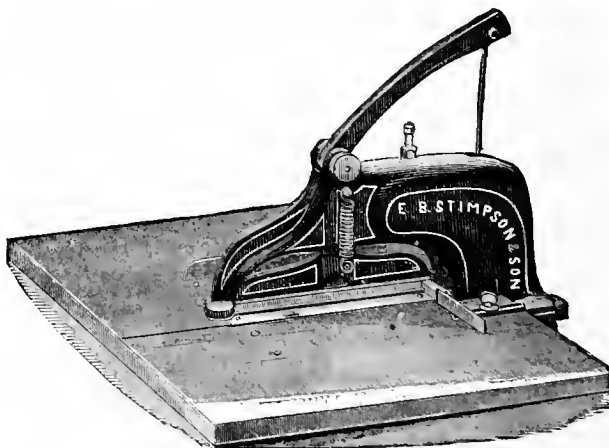

In every respect a perfect and superior machine, in keeping with the reputation of the makers, and well worth the price asked.

Perforates 10 inches with treadle.

\$40 00



## TREADLE PERFORATORS.

We list on this page two grades, each of which accomplishes the same work, the difference in prices indicating differences in workmanship and durability.

### STANDARD GRADE TREADLE PERFORATOR.



Round-hole perforators, with removable pins, with accurate gauges, and the best procurable at the price, meeting the requirements of the average binding and printing office.

Standard Grade, perforates 20 inches, with treadle	\$ 75 00
Standard Grade, perforates 24 inches, with treadle	100 00
Standard Grade, perforates 28 inches, with treadle	125 00
Standard Grade, perforates 24 inches, for power	150 00
Standard Grade, perforates 28 inches, for power	175 00

### GEM TREADLE PERFORATOR.

Gem, perforates 15 inches . . . . .	\$40 00
Gem, perforates 20 inches . . . . .	50 00
Gem, perforates 24 inches . . . . .	60 00
Gem, perforates 28 inches . . . . .	70 00

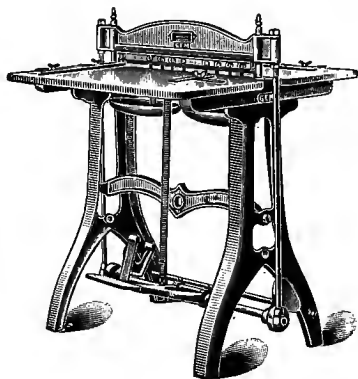

STIMPSON ROUND-HOLE PERFORATING MACHINES.

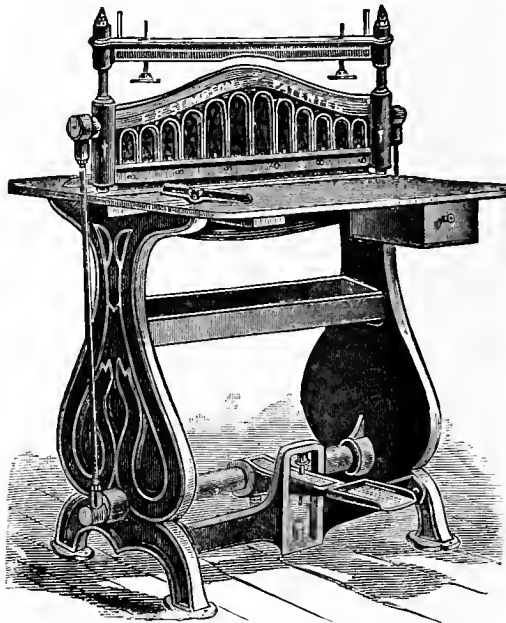

This illustrates the 25, 30 and 36-inch Stimpson Perforators.

This is conceded to be the best line of perforators made in the world. Nothing has been neglected in the way of good material, good workmanship and accurate adjustments, and consequently they do the best work, and wear longer than any other perforators. For those who keep a perforator in constant use an investment in one of these perforators will prove the most profitable, and will be found to keep up a perfect standard of work for many years. Power may be applied to any size.

These perforators are made to make two sizes of perforations—No. 60 gauge (15 holes to an inch), and No. 65 gauge (18 holes to an inch). The No. 65 gauge is the most satisfactory for checks, bonds, drafts, stubs and labels.



No. 65 Gauge.



No. 60 Gauge.

	No. 60 Gauge.	No. 65 Gauge.
20-inch machine, on substantial box-frame iron pedestal . . .	\$150 00	\$160 00
25-inch machine, as per illustration . . . . .	225 00	240 00
30-inch machine . . . . .	300 00	325 00
36-inch machine . . . . .	400 00	435 00

**POWER ATTACHMENT** for any of these machines, \$125 00 extra.

## PEERLESS ROTARY PERFORATOR.

For Power.

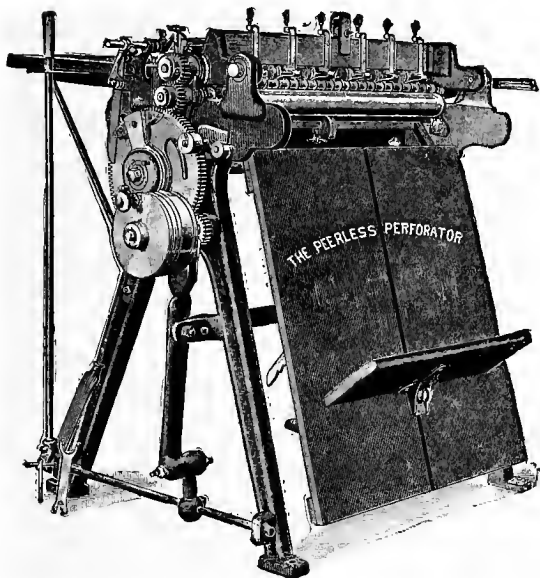

A thoroughly-tested, successful rotary power perforator, cutting six or less separate lines of perforations at a time, and provided with adjustable striking cams for skipping the perforations any distance, from the usual lengths of stubs to very short spaces. When the skip is as short as half an inch special fitting must be done, at a small extra expense. Accurate gauges, easily changed, are provided. The sheets deliver themselves after perforation into a lay-box, taking up very little room, and stacking the sheets regularly. Sheets are fed to machine as into a ruling machine.

Not the least remarkable feature is the form of the perforations, which are *cut out* of the paper cleanly, without any trace of burr, in oblong holes instead of the usual round holes. The machine will perforate a single sheet of manifold paper (without the usual aid of a thicker sheet) or heaviest manilla paper.

The oblong perforations are the distinctive feature of this machine. There is no displacement or swell of the paper along the perforated lines, and the clean cut of every hole, the absence of all burr, and the ease with which the paper separates through the perforations, commend the machine to all who aim to do the best grade of work.

This perforator is in use in a majority of the first-class manufacturing stationers and printing houses, and is built thoroughly well. All parts are interchangeable.

Price, with six pairs of cutters and one scoring cutter and die, f. o. b. Chicago,  
net . . . . . \$350 00

**STYLE 2-B HICKOK HAND STRIKER RULING MACHINE.**

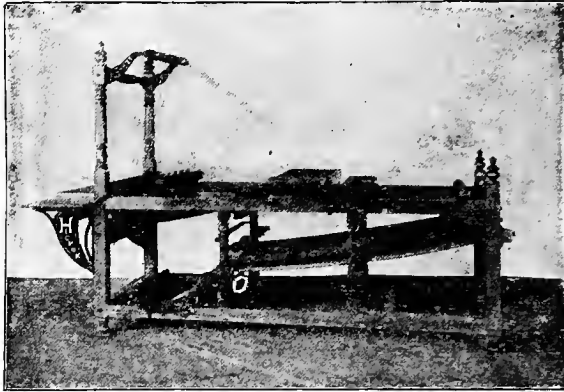

Designed for small shops, where ruling is not done very rapidly, and where, therefore, the ink has time to dry (though the carrier is short) after the paper has passed under the pens and before it drops into the receiving box at feeder's feet. So far as material and workmanship are concerned, there is nothing better made than Style 2-B. The difference between it and the higher-priced rulers is simply in the number of parts used. Striking is accomplished on this machine exactly as it is on the Style 1-A ruling machine. Paper drops into receiving box.

**STYLE 1-A HICKOK HAND STRIKER RULING MACHINE.**

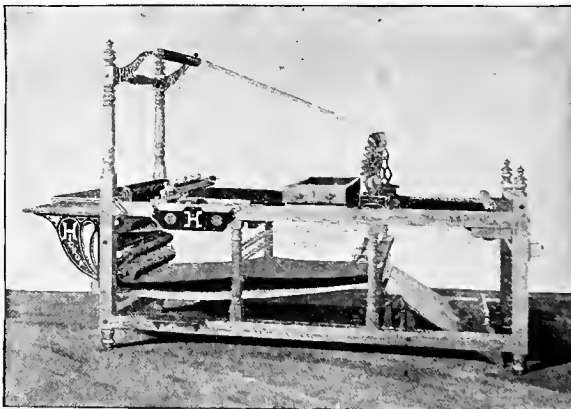

STYLE 1-A Ruling Machine is for use in shops where there is considerable faint or cross ruling, thus economizing the time of automatic strikers used in the same shop. It may also be used in small-sized binderies, where there is not sufficient work for an automatic striker machine. The operator turns the hand crank with the left hand, thus operating the machine by hand, while with the right hand the pen-beam is tilted up and down, doing hand striking. Power may be applied, and steam attachments are furnished to order at an extra charge. Style 1-A is as perfectly built in every part as the most expensive automatic striker ruling machine. The difference in construction is simply leaving off the striker parts and some other necessary pieces required on an automatic striker machine.

*For prices, see next page.*

**STYLE 1 SINGLE BEAM AUTOMATIC STRIKER RULING MACHINE.**

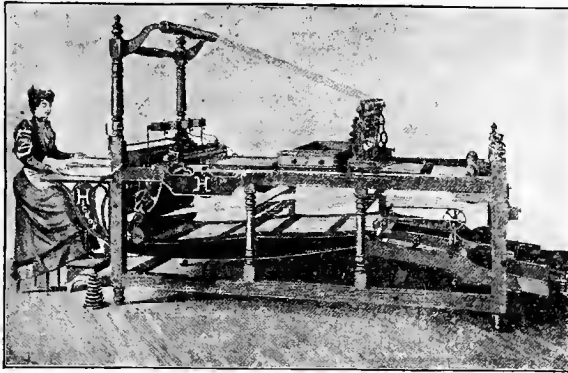

STYLE 1 is used for faint or cross-lining when the striker is not operated, and also for down ruling from cross or head lines when the automatic striker is used for the purpose of leaving unrulled head spaces by automatically raising the pens from the paper and allowing them again to descend upon the paper, the pens beginning to rule immediately upon touching the paper at a cross head line, and again being automatically raised from the paper and lowered upon the paper again successively at distances prearranged by the positions of the cams, which are adjusted by the operator, who sets them in the circular-revolving cam-head. This machine is for use on all classes of job ruling.

The illustration shows the combined lay-boy and receiver—a device for receiving the paper (after it is ruled) in the lower portion of the machine. Gears are used in setting the striker—friction devices being avoided because gears are more positive in the correct delivery of both speed and power.

**PRICES OF RULING MACHINES.**

2-B, with new Monitor standards, patent beam, patent pen rest, two 32-inch and two 26½-inch clamps, arranged to deliver paper in receiving box at feeder's end of machine (steam fixtures not included—\$15 extra, if required) . \$190 00

	WIDTHS {				
	Between Rails: Cloth Width:	38 inches. 32 inches.	42 inches. 36 inches.	44 inches. 38 inches.	48 inches. 42 inches.
STYLE 1-A, with Improved Receiving Box	\$235 00	\$275 00	\$285 00	\$305 00	\$335 00
With Lay-boy and Receiver	252 00	297 00	307 00	327 00	357 00
STYLE 1, with Receiving Box .	410 00	450 00	460 00	480 00	510 00
With Lay-boy and Receiver	427 00	472 00	482 00	502 00	532 00

**RULING PENS ON POINT SYSTEM.**

Made to adjust with point system of type bodies of the American Type Founders' Co.

Length of bars, 4¼ inches; six bars in a set. The number of pens on a bar can be calculated by any one familiar with point system of type bodies. Faint-line pens sold only in sets.

Faint-Line Pens, in bars (combs), from 7 point to 36 point, each pen . . . . .	\$0 01 ½
Regular Down-Line Pens (Striker Pens), singles, and No. 9 double, each pen . . . . .	0 02
Regular Down-Line Pens, triples, each pen . . . . .	0 02 ½
Extra Long Down-Line Pens (Shanghai), singles, doubles, and triples, each pen . . . . .	0 03
Extension Pens, soldered on brass, singles, doubles, and triples, each pen . . . . .	0 03 ½
Extension Pens, soldered on tin, singles, doubles, and triples, each pen . . . . .	0 02 ½

STANDING PRESSES.

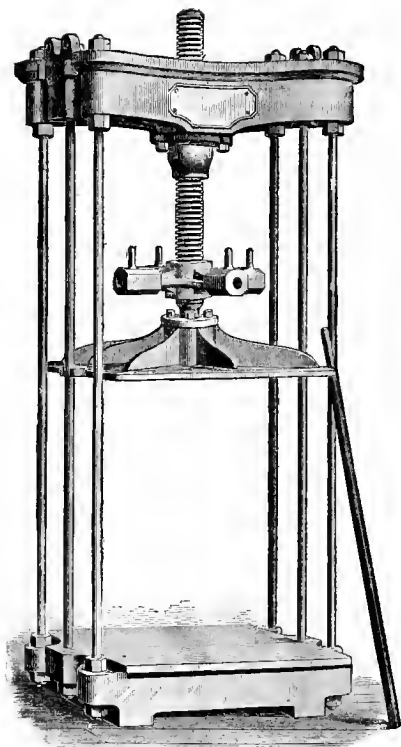

Illustrates Standing Presses Nos. 5 and 6, operated with spider and lever.

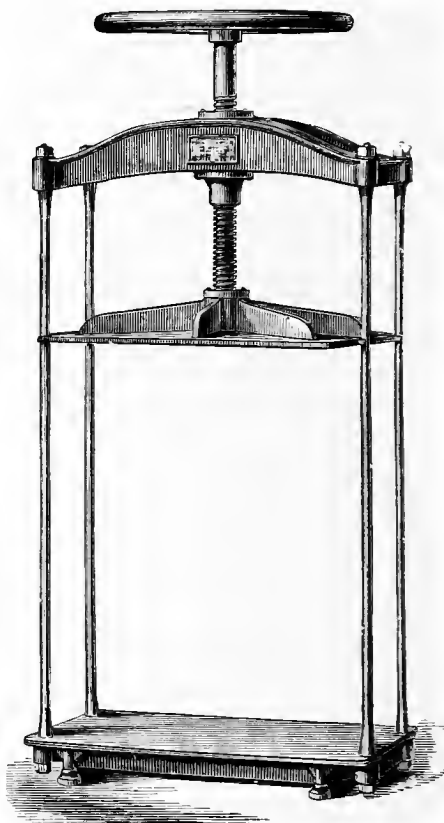

Illustrates Standing Presses, Nos. 2, 3 and 4, with hand wheel at top. No. 3 is also furnished with spider and lever.

These presses are very strong throughout—in top, base and platen.

No. 2 has four rods, and opens seven inches between bed and platen.

No. 3 has four rods, and opens thirty-seven inches.

No. 4 has four rods, and opens thirty-seven inches.

The Nos. 5 and 6 sizes have six wrought iron rods  $1\frac{1}{4}$  inches in diameter. The boxes for main screw are phosphor bronze. The No. 5 opens forty-six inches, and No. 6 opens forty-eight inches. The screw is of  $3\frac{1}{4}$ -inch steel, and is made all in one piece.

No. 2.—Size 16×16, operated by hand wheel at top, as shown in cut	\$25 00
No. 3.—Size 16×24, operated by a spider and lever	60 00
No. 4.—Size 16×24, operated by hand wheel at top	50 00
No. 5.—Size 20×28½, operated by a spider and lever, as shown in cut	110 00
No. 6.—Size 21×29, operated by a spider and lever	130 00

Boxing extra.

### BRASS-BOUND PRESS BOARDS.

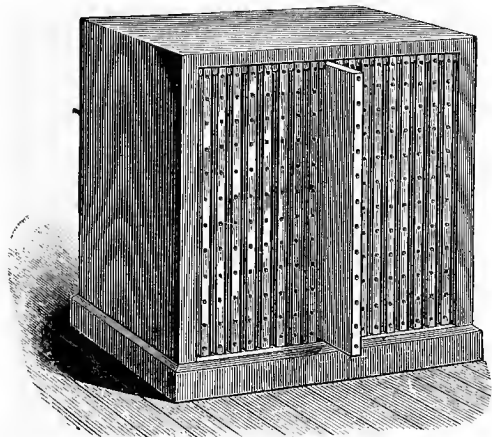

Made of seasoned, kiln-dried cherry, bound with hard brass, with folded corners.

16×24 inches, each . . . \$2 75 | Case to hold 18 boards . . . \$5 00

Other sizes made to order. Special quotations given on large orders.

### BOOKBINDERS' PRESS BOARDS.

Made from seasoned cherry, with cleated ends, and all guaranteed first-class, at the following prices, each :

6×10½ inches . . . \$0 20	12×16 inches . . . \$0 60	22×28 inches . . . \$1 30
8×10¾ inches . . . 0 25	12×18 inches . . . 0 70	24×30 inches . . . 1 35
8×12 inches . . . 0 30	13×20 inches . . . 0 75	24×32 inches . . . 1 45
10×13 inches . . . 0 35	15×20 inches . . . 0 80	26×40 inches . . . 2 80
11×14 inches . . . 0 45	16×24 inches . . . 0 95	30×36 inches . . . 3 25
10×16 inches . . . 0 55	20×24 inches . . . 1 05	36×44 inches . . . 4 50

Other sizes made to order at proportionate prices. Special quotations given on large orders.

### END-WOOD CUTTING BOARDS.

Made of end-wood, kiln-dried maple, any size desired. Each piece is grooved on all sides, and spliced and glued to the adjoining pieces, the result being the most durable and perfect cutting board which can be made.

Price, per square inch, face measure . . . \$0 02½

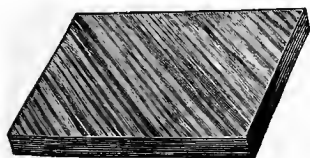
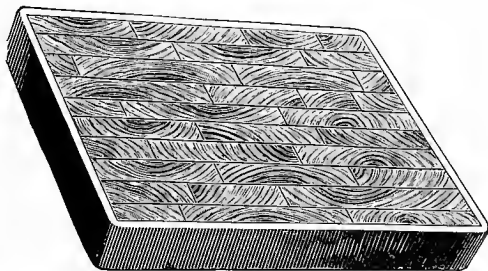

### DIAGONAL GRAIN CUTTING BOARDS.

Made of kiln-dried maple. The diagonal grain blocks are the best procurable for this purpose.

8×12 Board, diagonal grain, per pair . . .	\$1 75
8×12 Board, straight grain, per pair . . .	1 20
Larger sizes, straight grain, per square foot . . .	0 90
Larger sizes, diagonal grain, per square foot . . .	1 25

# FOR MAILING DEPARTMENT.

THE  
HORTON  
MAILER.

Patented  
May 11, 1894.

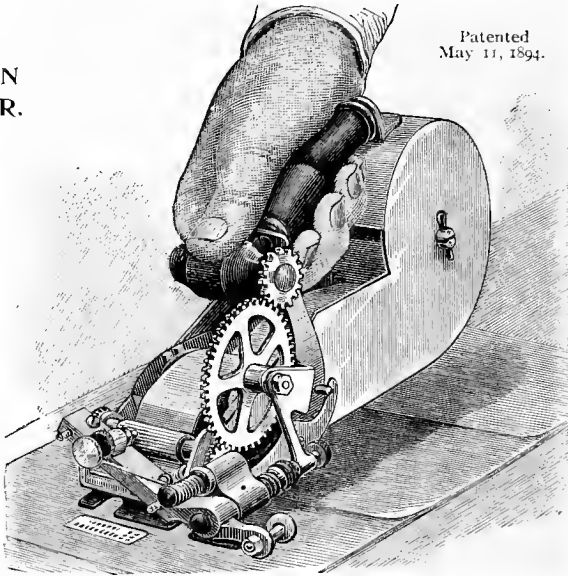

This is the best label-pasting mailer. It is quicker and more exact, because all its movements are positive. It is so simple that it can be worked rapidly and efficiently by the inexpert, while experts have addressed with it at the rate of 170 per minute. It is operated, as illustrated, by one hand, leaving the other entirely free to manipulate the papers or wrappers.

It guides and thoroughly pastes the slip, scrapes off all surplus paste, and sticks the label cleanly and firmly. The knives are thin and adjustable, with two cutting surfaces, and can be easily sharpened. The arrangements for adjusting knives with each other and regulating tension of knives are very exact.

It is very strongly made, and is the most durable of mailers.

*The Ladies' Home Journal*, Philadelphia; circulation, 690,000: "We have placed it in the hands of four of our experienced mailers, each having been given sufficient time to get acquainted with it, so that we might have more than one opinion. They were all satisfied that the machine is an improvement on any they have used. The Horton Mailer cuts and pastes the slip on the *Journal* or wrapper more thoroughly than the machines we have been using. . . . We do not believe it has an equal on the market to-day."

Price, with extra knives, paste strainer, screw driver and oiler, net . . . . \$20 00  
The exact size is 12 inches long by 3 inches wide by 5 inches high, and the weight is 2¾ pounds.

## GUM PASTE.

For Mailing Machines and for Wrapping.

To get the best results from a label-pasting mailer it is necessary to use a paste of exactly the proper consistency and of first-class sticking quality. This article is thin-flowing, stronger and better than ordinary flour paste. Sticks labels or wrappers quickly, and does not harden in the keg. It will keep for three months.

NET PRICES F. O. B. NEW YORK.

*Gum Paste is not kept in stock, but is shipped promptly on receipt of order.*

1-Gallon Pail . . . . .	\$0 65	10-Gallon Keg . . . . .	\$4 00
5-Gallon Keg . . . . .	2 25	25-Gallon Keg . . . . .	8 00



THE ACME MAILER.

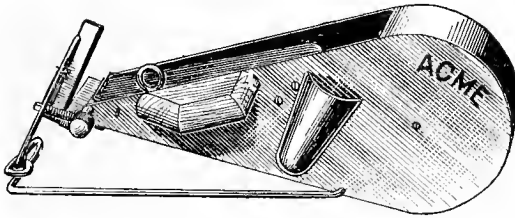

A good low-priced mailer, of which a great many are in use. It is built on the same lines as most of highest-priced mailers.  
 Price, net . . . . . \$15 00

RUKENBROD MAILER.

New Style.  
 All Metal.  
 With Bell Attachment.

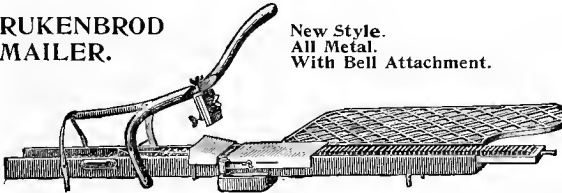

This mailer prints direct on the paper or envelope, clearly, and as rapidly as paper can be put under the platen. It is the best mailer of its class. Each address is brought under the platen automatically, and bell quads may be used which will ring an alarm bell when the papers for any town are all addressed, whereupon the next town wrapper address is printed. Each mailer is provided with two platens, one for two-line address and one for three- and four-line addresses. No other mailer of its class will print a four-line address.

All-metal mailer (as per illustration), net . . . . . \$12 50

RUKENBROD MAILING GALLEY.



Wood rim, zinc bottom . . . \$0 60  
 Wood rim, brass bottom . . . 0 85  
 Galley reglet, per hundred . . . 0 30  
 Bell quadrats, per hundred . . . 1 00

MUSTANG MAILER.

This mailer prints directly on the paper or envelope. The platen and its frame moves automatically, printing one address at a time. It will print three-line (8 Point) addresses.

The Mustang Mailer occupies a space of 37 inches in length and 4½ inches in width, and is made wholly of iron without springs or complications of any kind. Speed is regulated solely by the speed of operator in passing the papers to and from the mailer. The mail list is made up in galleys ten ems Pica wide on the inside.

Each galley holds seventy-five addresses. The weight of the machine is fifteen pounds, and of the galleys one pound.

Price . . . . . \$10 00

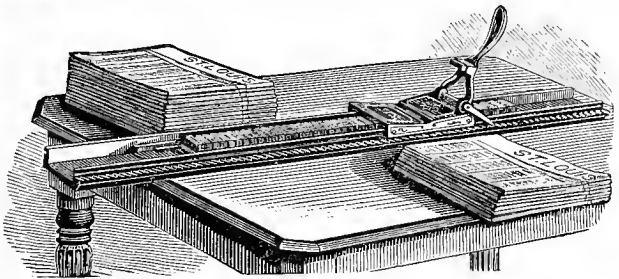

MUSTANG MAILING GALLEY.



Zinc bottom . . . \$0 50  
 Brass bottom . . . 0 75

**ECONOMY WRAPPER PASTER.**

Patent applied for.

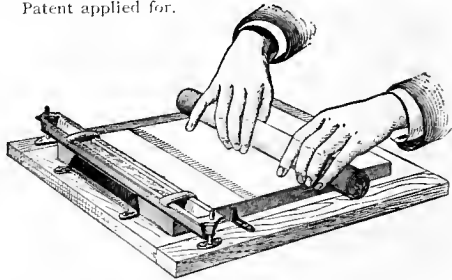

The paste fountain has a perforated bottom through which the paste reaches the top sheet of a pile, which may contain four hundred sheets. As the top sheet is drawn off, the next is pasted automatically and instantly, and so on. Wrappers are pasted as fast they can be drawn from the pile.

It saves all the time of "laying out" and applying paste with a brush, fifty per cent. in paste, and a great deal of space, as three or four hundred wrappers occupy no more table room than one, and you can wrap on top of the pile, as indicated in the cut.

**A SAMPLE EXPERIENCE—A REMARKABLE SAVING.**

CHICAGO GREAT WESTERN RAILWAY—PRINTING OFFICE.

CHARLES A. STICKNEY, SUPERINTENDENT PRINTING.

ST. PAUL, MINN., April 20, 1897.

*American Type Founders' Company:*

DEAR SIRS—In answer to your letter of April 13 about the "Economy Wrapper Paster": We have just finished wrapping an edition of fifteen thousand tariffs, 12 · 18 inches—28 pages. These tariffs were being wrapped at the rate of 250 per hour with a brush, while with the aid of your paster this was increased to 400 per hour. In every way I think it far ahead of a brush.

Yours truly,

CHARLES A. STICKNEY.

- |         |                                      |        |
|---------|--------------------------------------|--------|
| No. 10. | For width of 10 inches or less, each | \$4 00 |
| No. 14. | For width of 14 inches or less, each | 4 50   |
| No. 16. | For width of 16 inches or less, each | 5 00   |

**NEWSPAPER PASTER.**

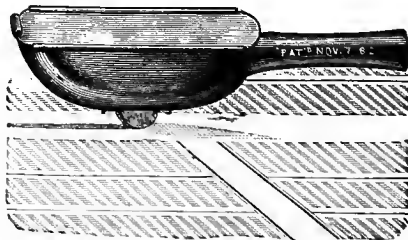

This is a tight brass box, with a handle, in which paste is put. In the bottom of the box a revolving wheel is placed which carries the paste out in a thin line to the sheet to be pasted. This wheel can be regulated to give a fine or coarse feed, as required.

The paster is carried in the hand between the thumb or forefinger while the sheets are being folded.

Price, complete, including two wheels and two gates . . . . . \$3 50

## MISCELLANEOUS SUPPLIES.

### BOOKS FOR PRINTERS.

<b>THE AMERICAN PRINTER:</b> A Manual of Typography. By Thomas MacKellar, Ph.D. 12mo. 400 pp., cloth .	\$2 00
<b>THE HARMONIZER:</b> Showing a great variety of harmonious effects produced by printing colored ink on colored paper. By J. F. Earhart. Size, 5×7½ inches. 248 pages, cloth .	5 50
<b>HINTS ON IMPOSITION.</b> By L. B. Williams. Leather, 90 pp.	1 00
<b>MANUAL OF PRINTING.</b> Vest-pocket size. 88 pp., leather .	0 50
<b>THE COLOR PRINTER.</b> Contains 625 different forms, and 1,625,000 impressions. An invaluable book. By J. F. Earhart. Size, 8¼×10½ inches. 227 pp., cloth .	10 00
<b>PRESS WORK:</b> A Manual for Pressmen. By Wm. J. Kelly. Cloth, 99 pp.	1 50
<b>INLAND PRINTER ACCOUNT BOOK:</b> A New and Correct System of Keeping Accounts in Printing Offices. Size, 10½×14½ inches, flat opening, leather back and corners, cloth sides. Price, 400 pp., for 2000 jobs, \$5 00; 200 pp., for 1000 jobs . . .	3 50
<b>THE INLAND PRINTER:</b> A Monthly Magazine. Size, 9×12 inches. From 90 to 110 pp., per issue. Per copy, 20 cents; per year	2 00
<b>EMBOSSING MADE EASY:</b> Instructions for Embossing by cheap processes	1 00
<b>AMERICAN DICTIONARY OF PRINTING AND BOOKMAKING.</b> Size, 8½×11 inches. 592 pp., half morocco .	12 00
<b>NEWSPAPERDOM:</b> A Weekly Journal for Printers and Publishers. Per year .	1 00
<b>WHITE'S MULTI-COLOR CHARTS:</b> Show seventy-three different specimens of paper, each leaf printed in six colors. Size, 6×12 inches .	1 00

### ENGRAVERS' TOOLS.



Six tools, sharpened for use, with handles, in box . . . \$2 50

### ENGRAVERS' WOOD.

Prepared to order, in the best manner. Prices are net. The minimum charge for Box-wood or Maple is twenty-five cents.

Boxwood, per square inch . . . . .	2 to 5 cents.
Maple, per square inch . . . . .	1½ cents.
Soft-wood Poster Tint Blocks, 27½×93¼ inches . . . . .	\$1 25 each.
Soft-wood Poster Tint Blocks, per square foot . . . . .	0 25

### REDUCING GLASS.

For ascertaining how far an engraving or drawing may be reduced with safety, and for ascertaining the effect which will be given by reductions of all kinds. In round metal frames with handle, three inches in diameter, each . . . \$1 50

### MAGNIFYING GLASS.

Every careful printer needs a magnifying glass. This glass is three inches in diameter, in a strong metal frame, with handle, each . . . . . \$1 65

THE SURGUY NEW HOT AIR STEREOTYPING APPARATUS.

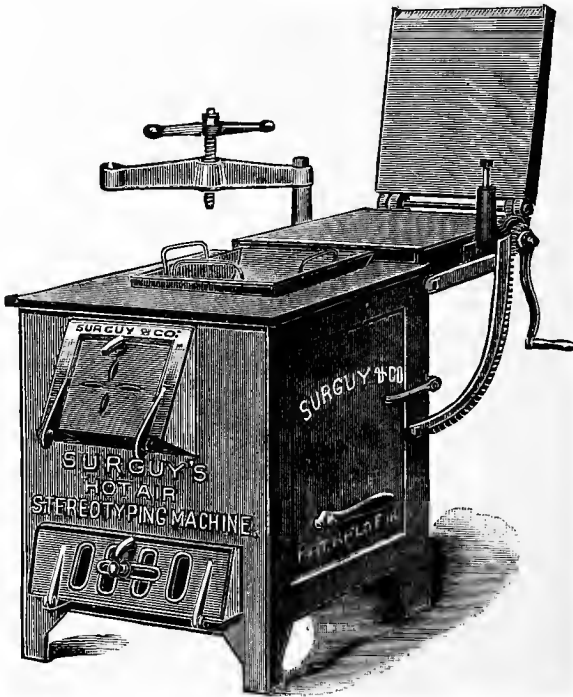

The furnace and casting box are combined. One fire of coal, wood or gas will melt metal and dry matrix simultaneously or separately if preferred, as metal pot is detachable. Each apparatus will make thin or type-high plates.

The 8½×14-inch apparatus will stereotype a form of 7½×10 inches. It is too small to use with wood or coal, and is fitted with a gasoline attachment, or gas may be used. The 12×20-inch apparatus will stereotype a form of 10×18 inches. The 18×26-inch apparatus will stereotype a form of 16×24 inches, taking in a standard six-column page of a newspaper.

PRICE OF APPARATUS AND OUTFIT.

	Size 8½ × 14 inches.	Size 12 × 20 inches.	Size 18 × 26 inches.
Combined furnace and casting box . . . . .	\$33 00	\$45 00	\$85 00
Iron bars, spacings and cores for type-high casts . . . . .	10 00	13 00	15 00
Iron shoot-board and plane . . . . .	9 00	12 00	15 00
Iron miter box and metal saw . . . . .	8 00	10 00	12 00
Beating brush . . . . .	3 00	3 00	3 00
Steel gauges for thin plates, small tools, blankets, brushes, prepared matrix paper, directions, etc. . . . .	7 00	7 00	10 00
Prices, when ordered complete . . . . .	\$65 00	\$90 00	\$140 00

PREPARED MATRIX PAPER.

Size, 12×19 inches, per dozen, by express . . . . .	\$0 50
Size, 19×24 inches, per dozen, by express . . . . .	1 00

## HOKE CROWN ENGRAVING PLATES.

(PATENTED.)

A Crown Engraving Plate consists of a thin, dark, steel plate, covered with a soft, white composition. By means of special tools, used after the manner of pens, the drawing is made by cutting through the composition to the dark surface of the steel plate, which shows the drawing as it will appear when printed. No apprenticeship is needed. Anyone able to draw can do the work. Speed is gained by practice. Three or four tools and a scraping brass is all that is required for ordinary work. After the drawing is finished, a stereotype cast is made from it and the cut is ready for the press. The quickness and cheapness of the process are apparent. Any stereotype foundry can cast the plates, but for those who desire to do their own casting we have special simple and cheap stereotyping outfits suited to every line of work.

This process is suitable for rapid newspaper illustration. A cut may be got ready inside of thirty minutes.

### PRICE LIST AND TELEGRAPH CODE.

The telegraphic code will be found convenient when plates are wanted in a hurry.

Size.	Net Price.	Tel. Code.	Size.	Net Price.	Tel. Code.
3 × 4 ins. . per doz.	\$ 4 50 .	— — — —	10 × 12 ins.	each, \$3 25 .	Hart.
3½ × 5 ins. . per doz.	6 50 .	Breton.	10 × 18 ins.	each, 4 25 .	Inness.
4 × 6 ins. . per doz.	9 00 .	Church.	12 × 16 ins.	each, 4 75 .	Johnson.
5 × 6 ins. . per doz.	11 00 .	Dore.	12 × 20 ins.	each, 5 75 .	Kelly.
5 × 8 ins. . per doz.	15 00 .	Errett.	16 × 16 ins.	each, 6 25 .	Leslie.
6 × 10 ins. . per doz.	21 60 .	Frost.	16 × 20 ins.	each, 7 75 .	Max.
8 × 10 ins. . . each,	2 50 .	Gaul.	18 × 20 ins.	each, 8 25 .	— — — —

A credit of 15 per cent. allowed for used base plates returned in good order, freight prepaid.

### HOKE STEREOTYPE CASTING BOXES.

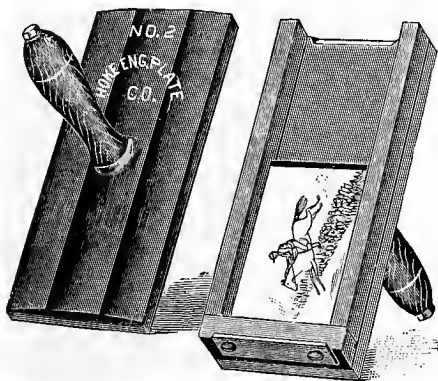

Fig. 1.

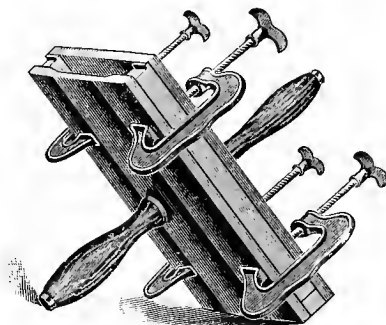

Fig. 2.

Figure 1 shows No. 2 Casting Box, with a 5×8 inch engraving plate laid in and the gauge bars adjusted to it, preparatory to putting on the top. Figure 2 shows the same, with the parts clamped together and ready to receive the molten metal.

No. 2 Casting Box, 5 × 8 inches, complete, for casting thin or type high . . . \$16 50 net.  
 No. 3 Casting Box, 8 × 10 inches, complete, for casting thin or type high . . . 22 00 net.

### APPLIANCES FOR ENGRAVING ON THE CROWN ENGRAVING PLATES.

Hoke Engraving Tools, set of four, with scraping brass . . . \$ 2 00 net.  
 Hoke Engraving Tools, each . . . 0 50 net.  
 Tracing Needles, for transferring drawing upon the composition of plate, each . . . 0 15 net.  
 Circle Former, for describing circles of all diameters, each . . . 0 75 net.  
 Plategraph, for tracing from drawing or print, reducing or enlarging the work . . . 12 50 net.

### AIR TOOLS FOR REMOVING DUST FROM PLATES.

Bulb Blower, operated by hand . . . \$ 1 00 net.  
 Foot Blower, operated by treadle, with stand and pump . . . 20 00 net.  
 Foot Blower, without stand . . . 15 00 net.

**HAMILTON NEWSPAPER FILE.**



Made of cherry, finished in oil, with brass fastenings and polished steel thumb-screws. The method of opening and closing this file is novel and simple. The clasp end of file has a flat-headed thumb-screw (see cut), which is passed through a slot, and by giving the screw a quarter turn the file is securely locked. When the head is turned parallel with the file it opens instantly.

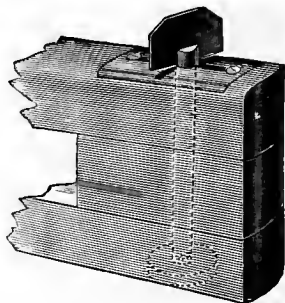

Fastening, closed.

Price, each

. \$1 25

The following sizes are made:

- |                            |                            |
|----------------------------|----------------------------|
| To hold sheet 20 in. long. | To hold sheet 28 in. long. |
| To hold sheet 22 in. long. | To hold sheet 30 in. long. |
| To hold sheet 24 in. long. | To hold sheet 34 in. long. |
| To hold sheet 26 in. long. | Other sizes to order.      |

**PANELED BACKING FOR ELECTROTYPES.**

The Only Backing that Will Not Warp Under any Circumstances.

These paneled blocks are made in two-foot lengths, and put up in any width desired. They usually are ordered with half-inch variations. This is the only perfect backing for large cuts. Sold in lots of fifty feet.

Price per square foot . . \$0 20

Special prices for large lots or regular supply. *Made to order only.*

**BACKING FOR ELECTROTYPES.**

Made from selected, well-seasoned stock, and kiln dried. This is supplied to any height desired, planed perfectly smooth and flat on both sides, uniform in thickness, and free from knots or waste. It is put up in boxes, each containing 100 feet, cut in 2-foot lengths, assorted widths,  $2\frac{5}{8}$ -inch high, for use without replaning, and  $\frac{3}{8}$ -inch high for replaning with Daniels Planer before use, but can be supplied to order to other thicknesses if required. The use of this backing results in saving of space and absence of waste.

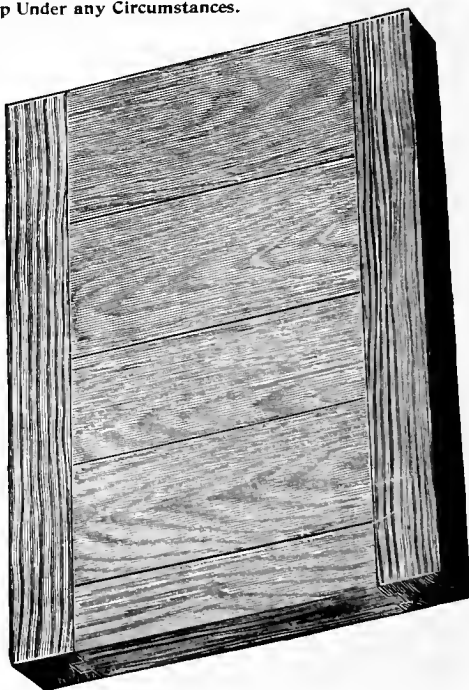

Birch, per square foot, in boxes of 100 feet . . . . .

. \$0 10

### SOLID-FACE TINT BLOCKS.

Most useful for the rapid setting up of tint forms. These blocks have a perfect, smooth surface, and print solidly.

1 Pica wide, per foot . . . . .	\$0 10	10 Picas wide, per foot . . . . .	\$0 48
2 Picas wide, per foot . . . . .	0 12	12 Picas wide, per foot . . . . .	0 50
3 Picas wide, per foot . . . . .	0 15	15 Picas wide, per foot . . . . .	0 66
4 Picas wide, per foot . . . . .	0 20	18 Picas wide, per foot . . . . .	0 75
5 Picas wide, per foot . . . . .	0 22	20 Picas wide, per foot . . . . .	0 80
6 Picas wide, per foot . . . . .	0 24	24 Picas wide, per foot . . . . .	0 85
8 Picas wide, per foot . . . . .	0 36		

*Prices are net.*

Larger pieces squared up, any size desired, at 1 cent per square inch.

### LABOR-SAVING TINT BLOCKS.

These consist of strips of engravers' maple, with polished face, cut to even Picas and Nonpareils in width. A font consists of two pieces each 1, 1½, 2, 2½, 3, 3½, 4, 5, 6 and 8 ems Pica wide, all eight inches long. All the printer has to do to make a tint is to set his panel to even Picas, select a tint strip of same width, and cut it the desired length.

Price, per font, net . . . . . \$1 00

### MAPLE BLOCKS.

The following are standard sizes, and are kept in stock at factory. Other sizes made to order for 1½ cents per square inch. Minimum charge, 25 cents. Prices are net.

10 × 10 inches . . . . .	\$1 00	15 × 15 inches . . . . .	\$2 25
10 × 12 inches . . . . .	1 20	16 × 18 inches . . . . .	2 88
12 × 12 inches . . . . .	1 44	12 × 24 inches . . . . .	2 88
12½ × 12½ inches . . . . .	1 50	18 × 18 inches . . . . .	3 24
14 × 14 inches . . . . .	1 96	15 × 30 inches . . . . .	4 50

### WOOD CIRCLES.

Made any size, mortised, with square or round bodies, as preferred. Prices are net.

1- to 2-inch diameter, inside, each . . . . .	\$0 40
2- to 4-inch diameter, inside, each . . . . .	0 75
4- to 6-inch diameter, inside, each . . . . .	1 00
6- to 8-inch diameter, inside, each . . . . .	1 25
8- to 10-inch diameter, inside, each . . . . .	1 75

# EVERYTHING FOR THE PRINTER



**E**VERYTHING made—Everything shown in any Price-List—Everything that may be made in the future—for use in the Printing Office can be purchased direct from any of the BRANCH HOUSES of the

## AMERICAN TYPE FOUNDERS CO.

**Y**OUR orders are solicited. All orders will be filled in accordance with the expressed preferences of customers. Our aim is to satisfy you as fully with Printing Material as we do with Type.

# BRANCHES COVERING THE CONTINENT

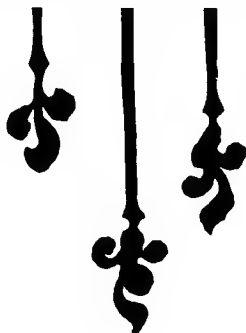



# USEFUL INFORMATION FOR PRINTERS.

## PROOFREADER'S MARKS.

- |                               |                      |                       |                                       |
|-------------------------------|----------------------|-----------------------|---------------------------------------|
| X Change bad letter.          | ○ Close up entirely. | / Hyphen.             | ¶ Paragraph.                          |
| ⤵ Push down space.            | ⊙ Period.            | /// Straighten lines. | No ¶ No paragraph.                    |
| 9 Turn.                       | / Comma.             | ☐ Move over.          | w. f. Wrong font.                     |
| 8 Take out ( <i>delete</i> ). | ⊖ Colon.             | ☐ Em-quad space.      | . . . . Let it stand.                 |
| ^ Left out; insert.           | ;/ Semicolon.        | /-/ One-em dash.      | stet. Let it stand.                   |
| # Insert space.               | ∨ Apostrophe.        | /-/- Two-em dash.     | tr. Transpose.                        |
| ∨ Even spacing.               | ∨ Quotation.         |                       | Caps Capital letters.                 |
| ∪ Less space.                 |                      |                       | s. c. Small caps.                     |
|                               |                      |                       | l. c. Lower case or<br>small letters. |
|                               |                      |                       | <i>Ital.</i> Italics.                 |
|                               |                      |                       | <i>Rom.</i> Roman.                    |

## TO PRINT CONSECUTIVE NUMBERS.

Orders to print consecutive numbers are received more or less frequently by every printing office, large or small. In the average office, to print the numbers 1 to 200 consecutively would be quite a task, and when undertaken in the ordinary way, with the facilities usually at hand, the cost is so high that the customer usually concludes to get along with something else than printed numbers, and what might be a profitable job is lost to the office.

A	B	C	D	E	F	G	H	I	K	L
1	11	21	31	41	51	61	71	81	91	01
2	22	32	42	52	62	72	82	92	02	12
3	33	43	53	63	73	83	93	03	13	23
4	44	54	64	74	84	94	04	14	24	34
5	55	65	75	85	95	05	15	25	35	45
6	66	76	86	96	06	16	26	36	46	56
7	77	87	97	07	17	27	37	47	57	67
8	88	98	08	18	28	38	48	58	68	78
9	99	09	19	29	39	49	59	69	79	89
0	00	10	20	30	40	50	60	70	80	90

Suppose an order for two hundred reserved seat numbers from 1 to 200, six copies of each. It is not necessary to set up more than the units 1 to 0. These figures are to be set up, properly spaced, one above the other, as shown in column A of the table annexed.

One hundred and twenty impressions are taken on strips of cardboard cut to the required width. This done, gives the required number of units. Change the gauge pins in a manner to print the same form beside the printed figures to form the tens, as shown in column B of the table. Take twelve impressions of this form on twelve of the already printed strips. The next step is to change the form by taking the top figure (1) and place it at the bottom of the column, so the next impression on a strip of the first form will read as shown in column C of the table. We print again twelve strips of the first form. This change of the top figures, 2, 3, 4, 5, 6, 7, 8, 9 and 0, respectively, is repeated eight more times, shown in the table as columns D, E, F, G, H, I, K and L. From each change twelve impressions on the printed slips containing the first form must be made. This will finish the tens, and by changing the form to ten figure 1s and again moving the pins to the left for the space-width of the type, and printing six strips of each the former changes from B to L, gives the hundreds, or a continuous run of numbers from 1 to 199 in an edition of six copies. To obtain number 200, print upon the six strips left a figure 2 to head the 00 of column B. In assorting the numbers it will be found that each six copies of the heavy type cannot be used, but this small loss in stock is compensated many times by the advantage derived from the method.

## IMPOSITION OF FORMS.

**HINTS ON IMPOSITION: A Hand-book for Printers.** By T. B. Williams. Leather, 90 pp., \$1.00. For sale at all Branches of the American Type Founders' Company, and recommended to all who desire the fullest information concerning the imposition of forms.

The make-up should learn to use the measuring rule or tape measure and dividers. They are more convenient to measure with than paper, and their use is regarded as evidence of knowledge of the imposition of book forms. The dividers will enable the make-up to verify his measurements quickly. Printers' dividers cost 85 cents.

Ascertain what furniture will be required for the margins of a book form before placing it upon the stone. Time will be saved, and the work will have the appearance of order and neatness.

After a book form is imposed, tighten the quoins, and ascertain by means of a straight-edge or square if the pages are of equal length and the head lines or bottom folios are exactly in line. The folios are usually the guides for hand-folding and should receive great attention, otherwise the binder will not secure good register. For the same reason, folios should all be set exactly in the middle of the width of the page.

After a book form has been locked up, it should be tested for squareness with a square. Forms are liable to get twisted or bowed in locking up, especially if the chase is weak. This defect can usually be remedied by loosening the quoins on one side and tightening them on the opposite side.

### MARGINS.

The proper allowances for head and back margins are matters of judgment and preference to a great degree.

The head and foot margins of a *trimmed* book are usually of equal proportions, but, as the binder will almost invariably find it necessary to cut off more paper from the foot than from the head, the make-up must make sufficient allowance for this extra trim.

When the pages have running heads one-third or less shorter than the width of the page, one-half of the space occupied by the running head should be thrown into the head margin, because the white around the running head is to be considered as part of the head margin. If a folio only is used over a page, the head margin is to be calculated from the top line of the page.

The make-up must know whether a book is to be wire-stitched through the back or sewed through the fold. If wire-stitched through the back, an extra allowance *additional* to the back margin required must be made a little in excess of the space used by the wire. This space varies according to thickness of the book, but is rarely less than three-sixteenths of an inch on *each side* of the back margin, or three-eighths of an inch in the back gutters.

In forms of 32 pages or more it is advisable, where it is possible, to impose the pages so that the sheet may be cut and folded in signatures of half the number of pages, especially when the paper is heavy; but if the form is imposed to fold as one complete signature then it is advisable to deduct enough from the back margin of the inner sections to equal the extra space taken up by the fold of the outside sections.

In imposing forms of 12 or 24 pages, great care must be taken to get the foot and head margins of the inset to be folded in exactly right, and the head and foot margins in such forms should be as evenly divided as possible. More accurate register is obtained when the inset is cut off and folded separately.

### TESTING MARGINS.

After the proper head and back margins have been decided on, and the pages arranged to conform to them, the form should be tested to ascertain if the foot and front margins are correct. The method is illustrated in the accompanying diagram of a section of a 16-page form. Fold a sheet to quarter of the size of the untrimmed paper to be used. The distance from the foot of page 16 to the foot of page 10 must agree with the length of the quarter sheet (as indicated by the dotted line), and the distance from the back edge of page 7 to the back edge of page 11 must correspond with the width of the quarter sheet. This test can be made just as well by using a measuring rule or tape, in which case, if the quarter sheet were twelve inches wide by eighteen inches long, the distance from the front edge of page 12 to the front edge of page 8 must be exactly twelve inches, and the distance from the foot of page 7 to the foot of page 1 must be exactly eighteen inches.

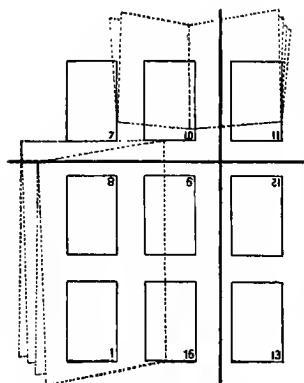

### GRIPPER MARGINS.

As applied to book forms, the space between the type and the outer edge of the chase at the gripper side is the gripper margin. A gauge showing the gripper margin of each press should be obtained from the pressman. When the paper is placed in its correct position on the type form, the distance between the edge of the paper and the edge of chase should be at least half an inch less than the gripper margin, to permit the pressman to move his form into a suitable place. To make a proper allowance for gripper margin, it is often necessary to place more furniture in the foot margins on the side of the long cross-bar next the gripper than on the other side. The lowest folio of a form should be placed next the gripper edge.

### CORRECT IMPOSITION OF LENGTHWISE CUTS AND TABLES.

The correct rule is that lengthwise tables and cuts shall always read from the foot of page. When a lengthwise cut or table is on one page and the explanatory or descriptive matter on the opposite page, then the cut or table should, if possible, be placed on the page with the even folio.

### TESTS OF CORRECT IMPOSITION.

As a general rule, except where for convenience in folding, certain forms are imposed from the center, the lowest (first) folio of a form is placed on the lower left-hand corner. All odd folios are always at the left-hand of the make-up, as viewed from the foot.

The odd and even folios of pages which are side by side in a correctly imposed regular form will, when added together, form a total of one more than the number of pages in a signature. The first and last pages of a signature are always placed side by side—as, for instance, in a 16-page form, where folios 1 and 16 equal seventeen.

### PRESS POINTS.

These are used in forms that are imposed for books, the sections of which are folded by machines. In 16-page forms these points are usually placed exactly 15 inches apart—7½ inches each way from the center of the first fold. The sheets are fed into the folding machine by the point holes to insure register, and the points should be placed exactly in accordance with the instructions of the bookbinder.

EIGHTS, IN TWO FORMS.

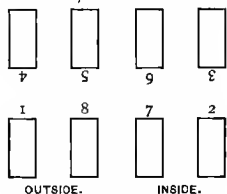

EIGHTS, WORK AND TURN.

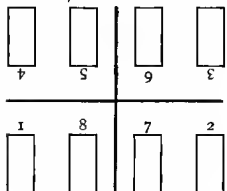

TWELVE, WITHOUT CUTTING.

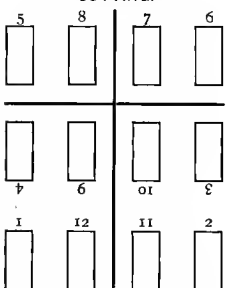

SIXTEEN, WORK AND TURN.

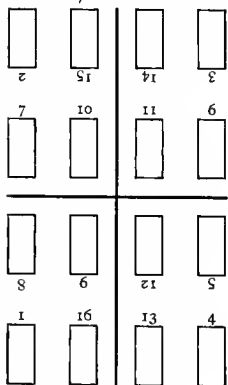

THIRTY-TWO PAGES, IN TWO FORMS.

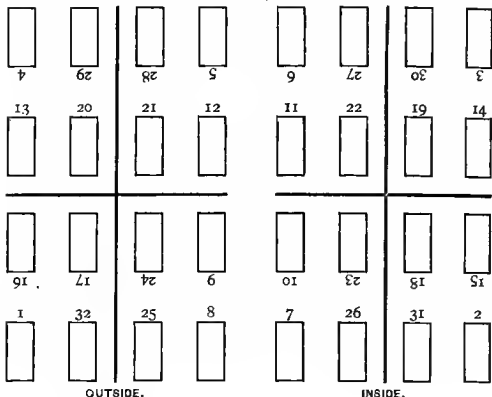

TWENTY-FOUR PAGES, IN TWO FORMS.

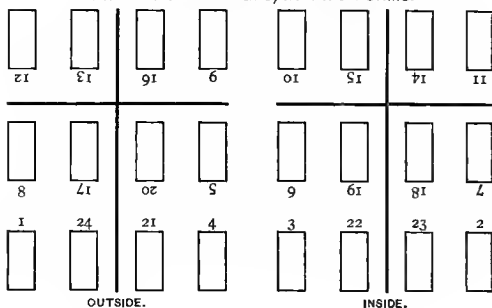

SIXTEEN PAGES, IN TWO FORMS.

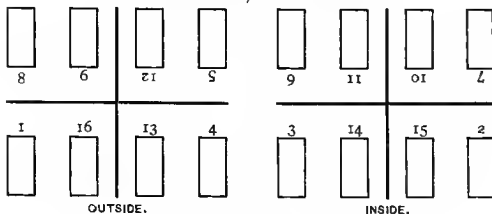

BROAD EIGHTS, IN TWO FORMS.

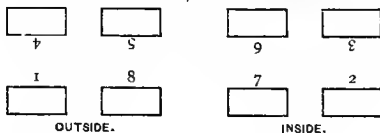

USEFUL INFORMATION FOR PRINTERS

SIXTEEN PAGES, DEEP WAY.

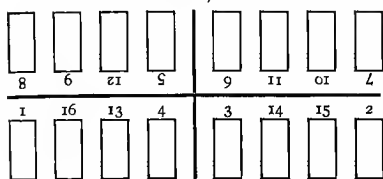

SIXTEEN PAGES, DEEP WAY.

For booklets. Paper should be trimmed before printing.

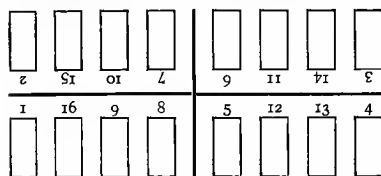

SIXTEEN PAGES, BROAD WAY, IN TWO FORMS.

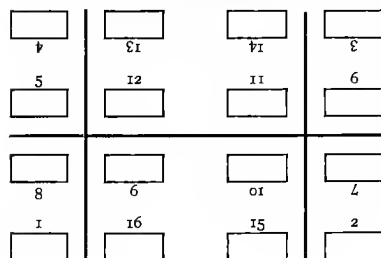

EIGHTEEN PAGES.

When the first side is worked off, transpose pages 11 and 8 in place of 7 and 12, and 7 and 12 in place of 11 and 8.

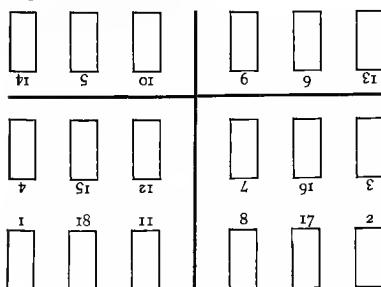

TWELVE PAGES, BROAD WAY.

In this form pages 3, 4, 9 and 10 are folded in. May frequently be used to advantage on booklets and catalogues.

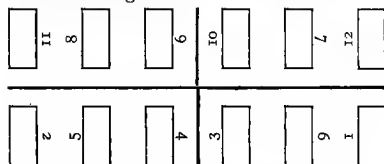

TWELVE PAGES, DEEP WAY.

This method is convenient only for deep pages, such as an odd-sized booklet, and the same size of paper used on the two regular forms for twelve pages may be used. Paper should be trimmed.

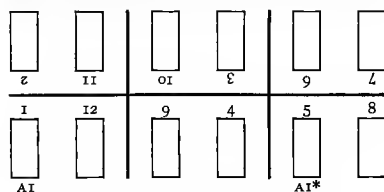

TWELVE PAGES, WITH OFF-CUT.

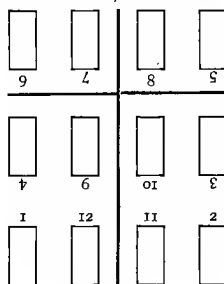

EIGHTEEN PAGES, WITHOUT TRANSPOSITION.

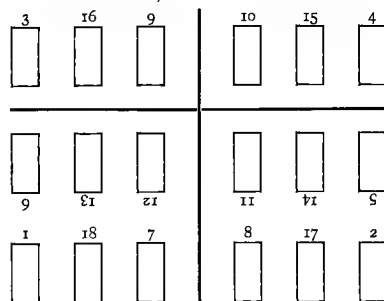

IMPOSITION OF FOLDERS.

The margins of folders are usually equal all around each page, and consequently accuracy in make-up and imposition is necessary. When the sheet is to be backed, turn it the broad way, toward the folio 2. Before printing, paper should be trimmed.

SIXTEEN-PAGE FOLDER.

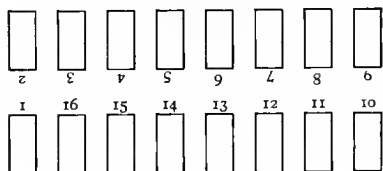

TWELVE-PAGE FOLDER.

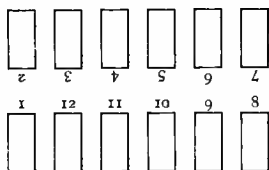

SIX-PAGE FOLDER.

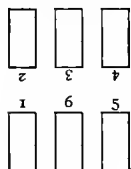

EIGHT-PAGE FOLDER.

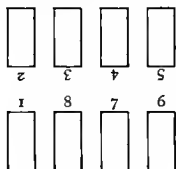

FORMS IMPOSED FROM THE CENTER.

This method of imposition is preferable in forms containing title page, copyright notice and other introductory pages with very little matter in them, as it brings the full pages outside, where they serve as bearers and often prevent slurring.

SIXTEEN PAGES, IMPOSED FROM CENTER.

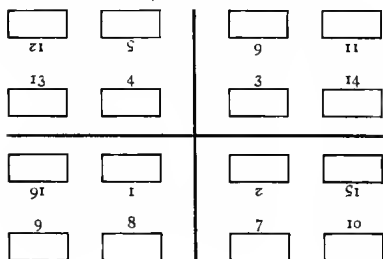

EIGHT PAGES, IMPOSED FROM CENTER.

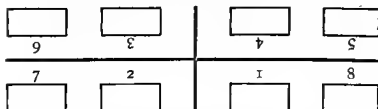

TWENTY FOUR PAGES, IMPOSED FROM THE CENTER, IN TWO FORMS.

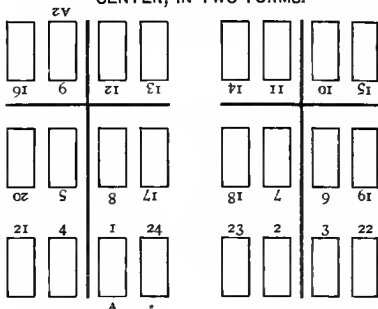

SIXTEEN PAGES, IMPOSED FROM CENTER.

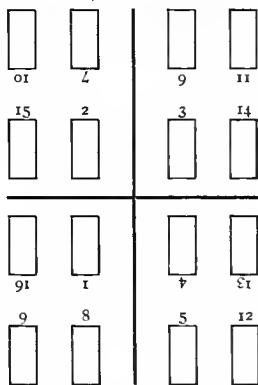

TWELVE PAGES, IMPOSED FROM CENTER.

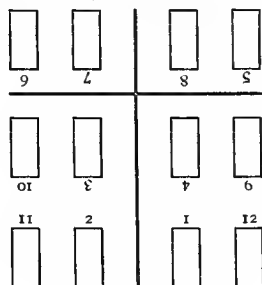

USEFUL INFORMATION FOR PRINTERS

TWENTY PAGES.

Printed on double demy or double royal. This method makes a square page, suitable for booklets, where oddity is looked for.

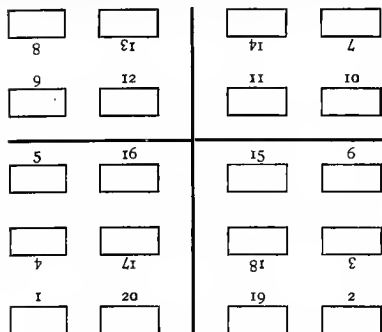

EIGHTEEN PAGES,  
TWO OF WHICH ARE BLANK.

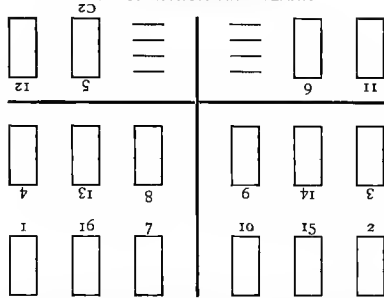

When the first side is worked off, transpose pages 7 and 10 in place of 9 and 8, and pages 9 and 8 in place of 7 and 10.

TWENTY-FOUR PAGES, DEEP WAY.

A very satisfactory form, in common use for pamphlets. Careful division of the margins is necessary, the pressman allotting the exact margin to the edge of the sheet to be folded in. Points placed as shown will assist the binder, and should be removed before backing the sheet.

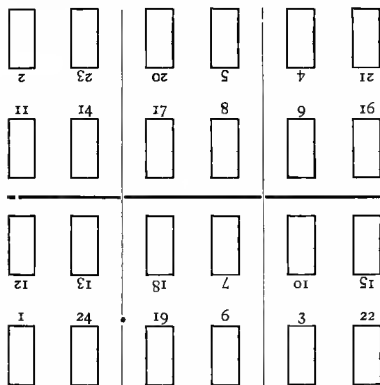

TWENTY-FOUR PAGES, WITHOUT INSET.

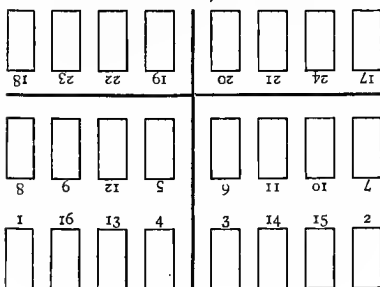

TWENTY-FOUR PAGES, WITHOUT CUTTING.

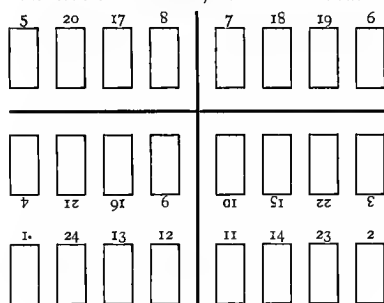

TWENTY-FOUR PAGES, BROAD WAY.

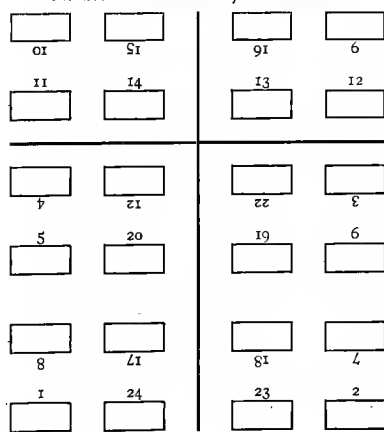

THIRTY-TWO PAGES, WITH TWO SIGNATURES.

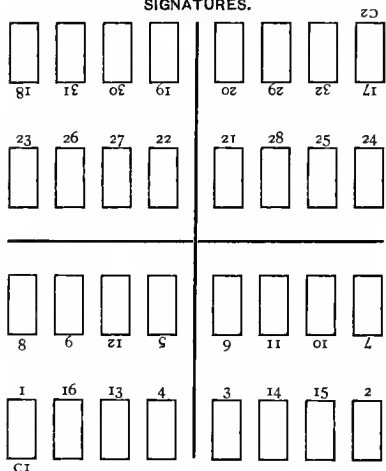

THIRTY-TWO PAGES, BROAD WAY.

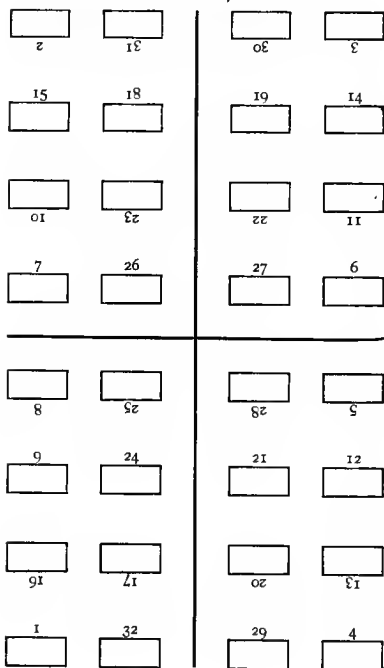

THIRTY-SIX PAGES.

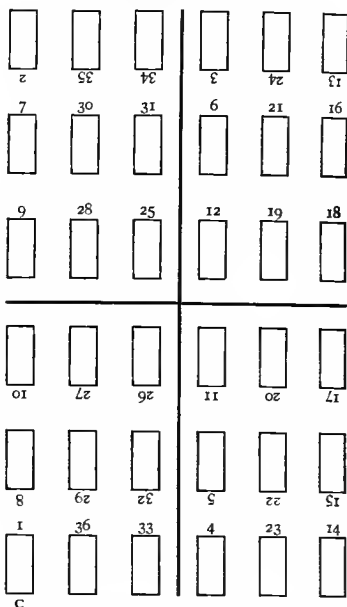

THIRTY-SIX PAGES, WITHOUT CUTTING.

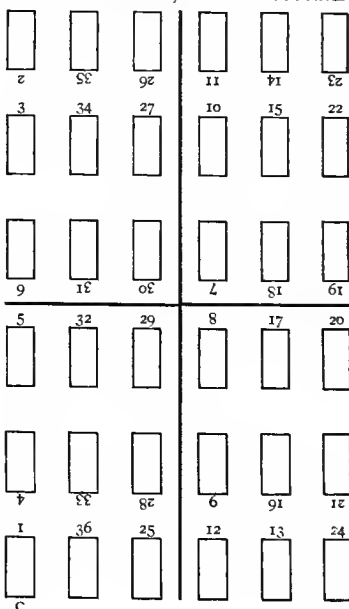



USEFUL INFORMATION FOR PRINTERS

FORTY PAGES, WITH TWO SIGNATURES.

The larger signature folds same as a 32-page form. The smaller signature is an inset.

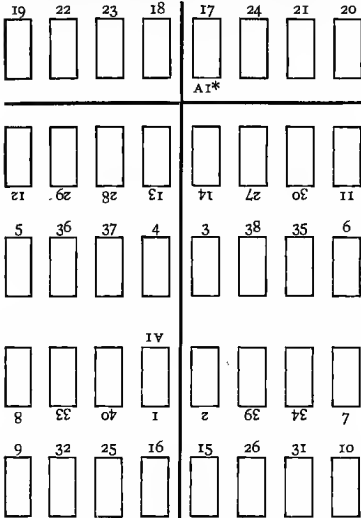

FORTY PAGES, WITH TWO SIGNATURES.

In this form there is an outset of pages, 1, 2, 3, 4, 37, 38, 39, 40, instead of an inset.

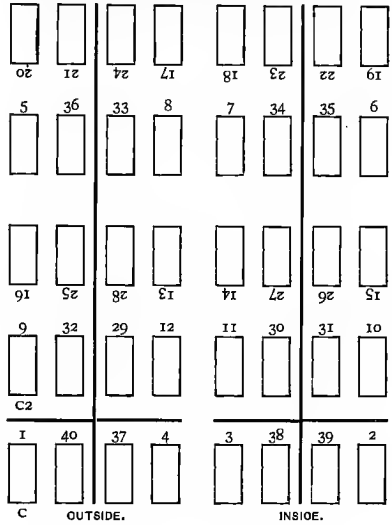

FORTY PAGES, ONE SIGNATURE.

The paper must be trimmed at ends before printing. A point should be placed where shown, about  $\frac{1}{4}$ -inch from the fold, encroaching on main section of form—the pressman to deduct this space from the edge of sheet, which is folded toward the form. The division of margin must be accurate, especially at head and foot of pages.

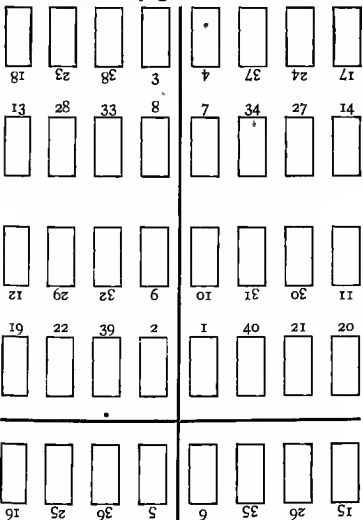

FORTY-EIGHT PAGES, WITH TWO SIGNATURES.

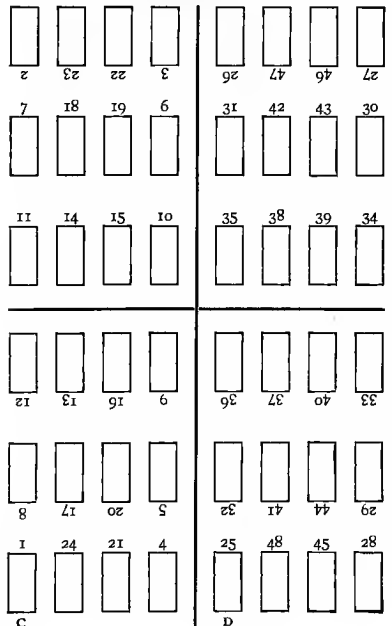

AMERICAN TYPE FOUNDERS COMPANY

FORTY-EIGHT PAGES, WITH THREE SIGNATURES.

								C
34	47	46	35	36	45	48	33	
39	42	43	38	37	44	41	40	
								B
18	31	30	19	20	29	32	17	
23	26	27	22	21	28	25	24	
8	9	12	5	6	11	10	7	
1	16	13	4	3	14	15	2	
A								

SIXTY-FOUR PAGES IN ONE SIGNATURE.

2	63	34	31	26	39	38	7
15	50	47	81	23	42	55	10
14	15	46	19	22	43	54	11
3	22	35	30	27	38	59	6
4	67	36	29	28	37	60	5
13	52	45	20	21	44	53	12
16	49	48	17	24	41	56	9
1	64	33	32	25	40	57	8
C							

SIXTEEN PAGES, FOR HEBREW WORK, IN TWO FORMS.

1	16	13	4	3	14	15	2
8	6	12	5	9	11	10	7

SIXTEEN PAGES, TWELVE OF ONE JOB AND FOUR OF ANOTHER, IN TWO FORMS.

11	11	8	5	6	7	14	1
1	12	6	4	3	10	11	2

# PRICE LIST OF PRINTING AND BINDING: A GUIDE FOR CHARGING.

Compiled by DAVID RAMALEY, St. Paul, Minn.

Copyrighted by David Ramaley, 1896.

The object of this publication is to unify prices, and to form a basis for agreements among printers in figuring on competitive work. The prices given are supposed to be fifty per cent. above the actual labor and material cost of the work, with ordinary conditions. The variable factor of general expense is only figured in the labor expense, because the paper or other stock used has a special expense of cutting and counting and handling equal to the proportion of general expense charge. *Twenty per cent. off from these prices will not leave twenty per cent. profit in all cases*, because sharp competition has forced down the prices of many kinds of commercial printing. A discount of twenty per cent. from the prices, in a general way, is supposed to leave twenty per cent. profit, but the factor of general expense must be considered.

## INDEX TO RAMALEY'S PRICE LIST.

	PAGE		PAGE
Abstracts of title . . . . .	214	Deposit books, bankers . . . . .	229
Advertising matter . . . . .	210, 214	Deposit tickets . . . . .	227
Advertising programmes . . . . .	214	Drafts . . . . .	227
Alterations . . . . .	210	Dodgers and hand bills . . . . .	215
Announcements, printed or engraved . . . . .	214	Engraved cards, invitations . . . . .	220
Ball and dance programmes . . . . .	220, 221	Envelopes . . . . .	225
Bank printing . . . . .	228	Envelopes, sizes of . . . . .	213
Basis for figuring value of paper . . . . .	212	Envelopes, tag, clasp, and stamped . . . . .	225
Beer, milk or restaurant tickets . . . . .	224	Guard or plat books . . . . .	234
Bill heads and monthly statements . . . . .	222	Hand bills or cheap circulars . . . . .	215
Bills of fare . . . . .	224	Hotel registers . . . . .	226
Binding, blank books . . . . .	234	Invitations, social and wedding . . . . .	220
Binding, books, magazines and newspapers . . . . .	236	Letter heads . . . . .	223
Binding, job work . . . . .	235	Note heads and memorandums . . . . .	224
Binding, pamphlets . . . . .	235	Numbering and perforating . . . . .	234
Blank books with stubs . . . . .	232	Paper, value of . . . . .	212
Blank books . . . . .	229	Paper, sizes of . . . . .	213
Blanks, ruled and printed . . . . .	228	Perforating and numbering . . . . .	234
Blotting pads . . . . .	221	Postal cards and stamped envelopes . . . . .	226
Bonds and coupons . . . . .	228	Posters and show bills . . . . .	215, 221
Booklets . . . . .	214	Presswork . . . . .	211
Briefs and paper books . . . . .	215	Programmes, dance and entertainment . . . . .	221
Bronze work . . . . .	211	Ruling on blank forms . . . . .	234
By-laws . . . . .	214	Restaurant bills-of-fare . . . . .	224
Card scale . . . . .	218, 219	Shipping tags . . . . .	226
Cards, business . . . . .	219, 220	Sizes of flat writing paper . . . . .	213
Cards, large or show . . . . .	221	Sizes of ruled paper . . . . .	213
Checks in book . . . . .	227	Sizes of untrimmed leaf . . . . .	213
Circulars, half note . . . . .	217	Stamped envelopes . . . . .	226
Circulars, folded note (1 to 4 pages) . . . . .	216	Standing type . . . . .	210
Circulars, quarter folio or letter . . . . .	216	Statements, monthly . . . . .	222, 223
Commission sales accounts . . . . .	234	Tags . . . . .	226
Composition . . . . .	210, 211	Time work . . . . .	210
Constitutions . . . . .	214	Value of paper . . . . .	212
Debit and credit slips . . . . .	227	Visiting and wedding cards . . . . .	220
Delegate or nomination tickets . . . . .	215	Wedding stationery . . . . .	220

## SAFE BASIS ON WHICH TO DO A PROFITABLE BUSINESS.

[Adapted from the Code of Ethics of the United Typothetae of America.]

The expense of doing business, such as the wear and tear of material, interest on money invested, bad debts, rents, taxes, insurance, book-keeping, and all other items of expense, should be ever before our eyes, and we should never forget that these must be as surely levied on each particular job as its labor costs.

Always have the courage to ask for a fair remuneration for any work offered, resting assured that it will be more profitable to be without a job than to secure one in which there is a temptation to resort to questionable methods in order to avoid a financial loss in its execution.

A master printer should always contend that he is entitled, when asked for an estimate, to know the names of all who are to be requested to bid on the work. He should also insist upon his right, if he desires it, to know all the prices offered for the work and to whom and at what price it was awarded.

A master printer should not make estimates for work that he cannot do. It is always unsafe and often unjust to give prices upon a class of work upon which the cost is not positively known and has to be guessed at.

Estimates calling for detailed specifications of separate value of the paper, composition, electrotyping, presswork, ruling, binding, etc., should always be refused.

## EXPLANATORY.

The prices under the several divisions of each list, such as "100," "250," "1000," include all regular charges for labor and material to the customer unless otherwise stated, and when there is a variable factor in such prices the amount estimated for such variable factor is quoted, so that the printer can readily adjust the price in accordance with the conditions governing the work. For instance, on page 214, in Advertising Programmes, the variable factor is composition. The price for 100 4-page Advertising Programmes on 22x32 quarto print paper is \$18.25, on the basis of 8-point composition, in which amount is *included* a charge of \$17.20, for composition at \$4.30 per page. Now, if composition should be based on 10 Point, *deduct* the difference in cost, and if on 6 Point, *add* the difference. In other instances the variable factor is the cost of paper.

We figure composition at 70c. per 1000 in all work, including locking up or making up, and at 60c. per hour for time work.

Paper is included in these prices at an average advance of 50 per cent. on cost, unless otherwise stated; but this includes storage, handling, wastage and cutting—items that are never paid for if the printer only adds 10 or 15 per cent. to cost of paper.

## COMPOSITION.

To be figured at 70c. per 1000 ems, and time work 60c. an hour.

**Alterations** to be figured separately from composition, and charged at the hour rate.

**Open Advertising Matter** on newspapers or programmes to be measured as 8 Point.

**Standing Type**, 1c. per square inch per month.

## COMPOSITION VALUES ON MISCELLANEOUS FORMS.

	4 TO SHEET CAP 89 SQ. IN.	4 TO SHEET FOLIO 60 SQ. IN.	4 TO SHEET ROYAL 70 SQ. IN.
Open blanks . . . . .	\$0.75	\$1.00	\$1.25
Open blanks and down rules	1.20	2.00	2.50
Labels, open . . . . .	1.20	2.15	2.50
Six Point . . . . .	3.30	5.80	7.00
Eight Point . . . . .	1.85	3.30	4.00
Ten Point . . . . .	1.20	2.15	2.50
Twelve Point . . . . .	.85	1.50	1.75

COMPOSITION VALUES—Continued.

	8 TO SHEET CAP 16 SQ. IN.	8 TO SHEET FOLIO 25 SQ. IN.	8 TO SHEET ROYAL 32 SQ. IN.
Open blanks . . . . .	\$.60	\$.75	\$1.00
Open blanks and down rules	1.00	1.50	1.80
Labels, open . . . . .	1.00	1.50	1.80
Six Point . . . . .	1.50	2.50	3.20
Eight Point . . . . .	1.00	1.50	1.80
Ten Point . . . . .	.70	1.00	1.20
Twelve Point . . . . .	.50	.75	.85
	12 TO SHEET CAP 10 SQ. IN.	12 TO SHEET FOLIO 20 SQ. IN.	12 TO SHEET ROYAL 25 SQ. IN.
Open blanks . . . . .	\$.50	\$.75	\$.75
Open blanks and down rules	.75	1.20	1.50
Labels . . . . .	.75	1.20	1.50
Six Point . . . . .	1.00	2.00	2.50
Eight Point . . . . .	.75	1.20	1.50
Ten Point . . . . .	.50	.75	1.00
Twelve Point . . . . .	.50	.60	.70
	18 TO SHEET CAP 12 SQ. IN.	18 TO SHEET FOLIO 18 SQ. IN.	18 TO SHEET ROYAL 22 SQ. IN.
Open blanks . . . . .	\$.50	\$.75	\$.75
Open blanks and down rules	.75	1.00	1.25
Labels . . . . .	.75	1.00	1.25
Six Point . . . . .	1.30	1.60	2.25
Eight Point . . . . .	.75	1.00	1.25
Ten Point . . . . .	.50	.65	.85
Twelve Point . . . . .	.50	.60	.70

Compare figures with time; estimates to include lock-up.

PRESSWORK.

The value of presswork is a difficult problem, because there are so many different grades of work. The prices in the following tables represent the value of good work. Since the introduction of plated papers and half-tone work rates may not be large enough for the best service, but on the average of work in an office the figures ought to be considered as fair and reasonable.

Flat papers,

	100	250	500	1000	ADDED 100
Double medium . . . . .	\$.175	\$2.10	\$2.60	\$3.50	\$.18
Double cap . . . . .	1.50	1.75	2.10	2.85	.13
Folio post . . . . .	1.00	1.30	1.60	2.35	.13
Flat cap . . . . .	1.00	1.30	1.60	2.35	.13
Half folio . . . . .	1.00	1.30	1.60	2.35	.13
Half cap . . . . .	.75	.90	1.15	1.65	.08
Quarter folio, long form . . . . .	1.00	1.30	1.60	2.35	.13
Quarter folio, regular . . . . .	.75	.90	1.15	1.65	.08
Quarter cap . . . . .	.75	.90	1.15	1.65	.08
Smaller sizes . . . . .	.60	.75	.90	1.30	.06

Print and cheap book.

38 x 50 . . . . .	2.00	2.50	3.00	4.50	.28
36 x 48 . . . . .	2.00	2.50	3.00	4.25	.26
32 x 44 . . . . .	2.00	2.50	3.00	4.00	.24
28 x 42 . . . . .	2.00	2.50	3.00	3.50	.22
25 x 38 . . . . .	1.75	2.25	2.75	3.00	.18
22 x 32 . . . . .	1.75	2.25	2.75	3.00	.15
Medium and folios . . . . .	1.00	1.30	1.60	2.35	.13
Half folio and caps . . . . .	1.00	1.30	1.60	2.35	.10
Half cap and quarter folios . . . . .	.75	.90	1.15	1.65	.08

Bookwork.

38 x 50 . . . . .	2.50	3.00	3.75	5.00	.30
36 x 48 . . . . .	2.50	3.00	3.75	4.75	.28
32 x 44 . . . . .	2.50	3.00	3.50	4.50	.25
28 x 42 . . . . .	2.50	3.00	3.50	4.00	.23
25 x 38 . . . . .	2.00	2.50	3.00	3.50	.20
22 x 32 . . . . .	2.00	2.40	2.75	3.25	.17
19 x 25 . . . . .	1.50	2.00	2.50	3.00	.14

Half-tone work on highly finished or plated papers add 25 per cent. to book-work scale.

Bronze work, double presswork.

**BASIS FOR FIGURING VALUE OF PAPER.**

The basis for figuring the value of paper will be 50 per cent. on the cost price. This price is to include the proportionate cost of general expense and handling in every way—the opening, cutting, and repacking and waste.

Unless there is a special determination by the customer as to the quality of papers, figures will be based on grades of book and writing papers as follows:

Print paper, 2¾c., to be figured at . . . . .	4½	Tub sized, 11c., to be figured at . . . . .	18
Colored print, 4c., to be figured at . . . . .	6	Water marked, 13c., to be figured at . . . . .	20
Common book, 4c., to be figured at . . . . .	6	Linen, 14c., to be figured at . . . . .	21
S. & C. book, 4½c., to be figured at . . . . .	7	Fine linen, 16c., to be figured at . . . . .	24
S. & S. C. book, 5c., to be figured at . . . . .	7½	Superfine linen, 18c., to be figured at . . . . .	27
Plated book, 8c., to be figured at . . . . .	12	Pure linen, 21c., to be figured at . . . . .	30
Manilla, 4¾c., to be figured at . . . . .	6½	Crane's linens, 24c., to be figured at . . . . .	35
Engine sized, 7c., to be figured at . . . . .	11		

**PRINTERS' VALUE OF 1000 SHEETS PAPER OF THE WEIGHT DESIGNATED AT TOP OF COLUMN.**

The basis for figuring the value of paper is 50 per cent. on the cost price.

	2-LB.	4-LB.	16-LB.	18-LB.	20-LB.	22-LB.
Costing \$0.02 per lb.	\$0.75	\$0.87	\$1.00	\$1.13	\$1.25	\$1.38
Costing .02½ per lb.	.94	1.09	1.25	1.41	1.57	1.73
Costing .03 per lb.	1.13	1.32	1.50	1.69	1.88	2.07
Costing .03½ per lb.	1.32	1.54	1.75	1.97	2.19	2.42
Costing .04 per lb.	1.50	1.75	2.00	2.25	2.50	2.75
Costing .05 per lb.	1.88	2.18	2.50	2.82	3.13	3.45
Costing .05½ per lb.	2.06	2.41	2.75	3.10	3.44	3.78
Costing .06 per lb.	2.25	2.63	3.00	3.38	3.75	4.13
Costing .06½ per lb.	2.44	2.85	3.25	3.66	4.07	4.47
Costing .07 per lb.	2.63	3.07	3.50	3.94	4.38	4.81
Costing .07½ per lb.	2.81	3.27	3.75	4.22	4.69	5.18
Costing .08 per lb.	3.00	3.50	4.00	4.50	5.00	5.50
Costing .08½ per lb.	3.19	3.72	4.25	4.78	5.31	5.84
Costing .09 per lb.	3.38	3.94	4.50	5.06	5.63	6.19
Costing .09½ per lb.	3.56	4.15	4.75	5.34	5.94	6.53
Costing .10 per lb.	3.75	4.35	5.00	5.63	6.25	6.90
Costing .10½ per lb.	3.94	4.60	5.25	5.90	6.57	7.22
Costing .11 per lb.	4.12	4.81	5.50	6.19	6.88	7.56
Costing .11½ per lb.	4.32	5.04	5.75	6.48	7.20	7.92
Costing .12 per lb.	4.50	5.25	6.00	6.75	7.50	8.25
Costing .12½ per lb.	4.68	5.46	6.25	7.02	7.80	8.58
Costing .13 per lb.	4.88	5.70	6.50	7.32	8.13	8.94
Costing .14 per lb.	5.25	6.13	7.00	7.88	8.75	9.62
Costing .15 per lb.	5.62	6.53	7.50	8.44	9.38	10.35
Costing .16 per lb.	6.00	7.00	8.00	9.00	10.00	11.00
Costing .17 per lb.	6.38	7.44	8.50	9.56	10.62	11.68
Costing .18 per lb.	6.75	7.88	9.00	10.12	11.25	12.38
Costing .19 per lb.	7.12	8.30	9.50	10.68	11.88	13.06
Costing .20 per lb.	7.50	8.70	10.00	11.25	12.50	13.80
Costing .21 per lb.	7.88	9.20	10.50	11.80	13.14	14.44
Costing .22 per lb.	8.24	9.62	11.00	12.38	13.75	15.12
Costing .23 per lb.	8.64	10.08	11.50	12.96	14.40	15.84
Costing .24 per lb.	9.00	10.50	12.00	13.50	15.00	16.50
Costing .25 per lb.	9.36	10.92	12.50	14.04	15.60	17.16

For other weights combine or divide the figures.

American linen and similar grades: 14-lb., \$9.80; 16-lb., \$11.20; 18-lb., \$12.60; 20-lb., \$14.00.

Crane Bros'. all linen and similar goods, 500 sheets to ream: 16-lb., \$11.20; 20-lb., \$14.00; 24-lb., \$16.80.

Japanese linen and similar goods, 480 sheets to ream: 20-lb., \$14.00; 24-lb., \$17.30; 28-lb., \$18.80.

**Ledger papers, per 100 sheets (Weston or Brown).**

- Demy, 28-lb., \$2.15; 30-lb., \$2.40.
- Medium, 36-lb., \$3.00; 40-lb., \$3.50.
- Double cap, 36-lb., \$2.50; 40-lb., \$2.80.
- Royal, 44-lb., \$3.70. Super royal, 54-lb., \$5.00.
- Double demy, 56-lb., \$4.25.
- Double medium, 72-lb., \$6.00; 80-lb., \$7.00.

**RAMALEY'S PRICE LIST OF PRINTING**

**SIZES OF FLAT WRITING PAPER.**

Flat Letter . . . . .	. 10 × 16	Double Demy, narrow . . . . .	. 16 × 42
Flat Packet or Packet Post . . . . .	. 12 × 19	Double Demy, broad . . . . .	. 21 × 32
Flat Foolscap or Small Cap . . . . .	. 13 × 16	Elephant . . . . .	. 23 × 28
Flat Cap . . . . .	. 14 × 17	Medium . . . . .	. 18 × 23
Crown or Crown Cap . . . . .	. 15 × 19	Imperial . . . . .	. 23 × 31
Double Letter . . . . .	. 16 × 20	Double Medium, narrow . . . . .	. 18 × 46
Demy . . . . .	. 16 × 21	Double Medium, broad . . . . .	. 23 × 36
Folio Post or Folio . . . . .	. 17 × 22	Double Royal . . . . .	. 24 × 38
Double Folio . . . . .	. 22 × 34	Double Elephant . . . . .	. 27 × 40
Double Cap . . . . .	. 17 × 28	Columbier . . . . .	. 23 × 34
Small Double Cap . . . . .	. 16 × 26	Atlas . . . . .	. 26 × 33
Royal, Double Packet or Packet Folio . . . . .	. 19 × 24	Antiquarian . . . . .	. 31 × 53
Super Royal . . . . .	. 20 × 28	Cardboard . . . . .	. 22 × 28

**SIZES OF RULED PAPER.**

	INCHES.	SHEET.		INCHES.	SHEET.
Commercial Note Heads . . . . .	5½ × 8½	⅓ Folio	Bill Heads—Thirds, 1500 to Ream . . . . .	8½ × 9½	⅓ D. Cap
Hotel Note Heads . . . . .	5½ × 11	⅓ Folio	Bill Heads—Halves, 1000 to Ream . . . . .	8½ × 14	⅓ Cap
Packet Note Heads . . . . .	5½ × 9	⅓ Medium	Regular Statements . . . . .	5½ × 8½	⅓ Folio
Royal Packet Note Heads . . . . .	6 × 9½	⅓ Royal	Hotel Statements . . . . .	5½ × 11	⅓ Folio
Demy Letter Heads . . . . .	8 × 10½	⅓ Demy	Head and Tail Statements . . . . .	5½ × 8½	⅓ Folio
Folio Letter Heads . . . . .	8½ × 11	⅓ Folio	Gem Statements . . . . .	3¾ × 5½	
Memorandum Heads . . . . .	5½ × 8½	⅓ Folio	Infant Statements . . . . .	4¾ × 5½	
Bill Heads—Sixes, 3000 to Ream . . . . .	8½ × 4¾	⅓ Cap	Square Statements . . . . .	5½ × 5½	
Bill Heads—Quarters, 2000 to Ream . . . . .	8½ × 7	⅓ Cap	Yankee Statements . . . . .	3¾ × 8½	

**REGULAR ENVELOPE SIZES.**

<b>BANK.</b>		<b>COIN.</b>		<b>PAMPHLET.</b>	
No. 6 . . . . .	4¾ × 6¾	No. 9 . . . . .	3½ × 8½	No. 2 . . . . .	6½ × 10
" 7 . . . . .	4½ × 7½	" 10 . . . . .	4¼ × 9½	" 3 . . . . .	6¾ × 10½
" 8 . . . . .	5 × 7½	" 11 . . . . .	4½ × 10¾	<b>PAY.</b>	
<b>BARONIAL.</b>		" 12 . . . . .	4¾ × 11	No. 2 . . . . .	2 18 × 4 18
No. 4 . . . . .	3½ × 4 18	" 14 . . . . .	5 × 11 ½	<b>PHOTOGRAPH.</b>	
" 5 . . . . .	4 18 × 5 18	<b>OPEN END.</b>		<b>OPEN END.</b>	
<b>COMMERCIAL.</b>		No. 3 . . . . .	2½ × 4¾	Cabinet . . . . .	4 18 × 7¾
No. 3 . . . . .	2 18 × 4¾	" 5 . . . . .	2¾ × 5¾	Wide Imperial Cabinet . . . . .	5¾ × 7¾
" 4 . . . . .	2¾ × 5¾	" 7 . . . . .	3¾ × 5¾	<b>PORTFOLIO.</b>	
" 5 . . . . .	3¾ × 5¾	<b>DRUG.</b>		No. 1 . . . . .	5½ × 8½
" 6 . . . . .	3½ × 6	No. 1 . . . . .	1¾ × 2½	" 2 . . . . .	6¾ × 8¾
" 6¾ . . . . .	3¾ × 6½	" 2 . . . . .	2 18 × 3¾	" 3 . . . . .	6 18 × 9 18
" 7 . . . . .	3¾ × 6 18	" 3 . . . . .	2 18 × 3¾		

**SIZES OF THE UNTRIMMED LEAF.**

Folio . . . . .	12 × 19	inches
Quarto, 4 to . . . . .	9½ × 12	"
Imperial 8 vo or 8° (octavo) . . . . .	8¾ × 11½	"
Super Royal 8 vo or 8° (octavo) . . . . .	7 × 11	"
Royal 8 vo or 8° (octavo) . . . . .	6½ × 10	"
Medium 8 vo or 8° (octavo) . . . . .	6 × 9½	"
Demy 8 vo or 8° (octavo) . . . . .	5¾ × 8¾	"
Medium 12 mo or 12° (duodecimo) . . . . .	5½ × 7¾	"
Medium 16 mo or 16° (sextodecimo) . . . . .	4¾ × 6¾	"
Cap 8 vo or 8° (octavo) . . . . .	4¼ × 7	"
Medium 18 mo or 18° (octodecimo) . . . . .	4 × 6¾	"
Super Royal 32mo (tricesimo secundo) . . . . .	3¾ × 5½	"

**ADVERTISING PROGRAMMES.**

Composition on advertising programmes is properly rated as 8 Point, and if the programme itself is set in 6 Point an extra charge should be made of \$1.00.

Folding not included in following figures.

	PRINT PAPER.	BOOK PAPER.
<b>Four Pages—Quarter sheet of 22 x 32.</b>		
100 copies, 13 ems, 3 columns to page, composition, per page, \$4.30	\$18.25	\$18.30
Added 100 copies	.26	.31
Added 1,000 copies	2.50	3.00
<b>Four Pages—Quarter sheet of 24 x 36.</b>		
100 copies, 15 ems, 3 columns to page, composition, per page, \$5.60	23.50	23.60
Added 100 copies	.27	.32
Added 1,000 copies	2.60	3.10
<b>Four Pages—Quarter sheet of 25 x 38.</b>		
100 copies, 16 ems, 3 columns to page, composition, per page, \$6.10		25.55
Added 100 copies		.35
Added 1,000 copies		3.40
<b>Four Pages—Quarter sheet of 26 x 40.</b>		
100 copies, 13 ems, 4 columns to page, composition, per page, \$7.50	31.20	
Added 100 copies	.29	
Added 1,000 copies	2.75	
<b>Four Pages—Quarter sheet of 28 x 42.</b>		
100 copies, 13 ems, 4 columns to page, composition, per page, \$8.10	33.60	33.70
Added 100 copies	.30	.38
Added 1,000 copies	2.80	3.70

Half the size, at two-thirds the rate.

**Advertising matter** on newspapers or programmes to be measured as 8 Point.

**Alterations** to be figured separately from composition and charged at the hour rate of 60 cents.

**BY-LAWS, CONSTITUTIONS AND SMALL BOOKLETS.**

Size of printed page, 3 1/2 x 5 1/2 inches, trimmed, 32 to sheet of 22 x 32 40-lb. book paper and 50-lb. cover paper.

	8 POINT TYPE.	7 POINT TYPE.	6 POINT TYPE.
8 pages (15 x 27 ems) and cover	\$ 7.75	\$ 9.40	\$11.65
Added 100 copies	.55	.55	.55
500 copies	9.95	11.60	13.85
1000 copies	12.70	14.35	16.60
Added 1000 copies	5.50	5.50	5.50
16 pages (15 x 27 ems) and cover	13.00	16.30	20.80
Added 100 copies	.75	.75	.75
500 copies	16.00	19.30	23.50
1000 copies	19.75	23.05	27.55
Added 1000 copies	7.50	7.50	7.50
24 pages (15 x 27 ems) and cover	19.30	24.25	31.00
Added 100 copies	1.05	1.05	1.05
32 pages (15 x 27 ems) and cover	25.00	31.60	41.00
Added 100 copies	1.30	1.30	1.30

**ABSTRACTS OF TITLE.**

Printed on half sheet of 16-lb. flat cap, usually set in 10 Point type, hanging indention, one full page, with backing :

100 copies (composition, \$4.00)	\$5.30
Additional 100 copies	.40
Additional pages, 100 copies	4.05
Added 100 copies	.40

Printed on ruled paper, separating descriptions, add \$1.00 for each page to above prices.

Cover and backing, add \$2.00.



**BRIEFS AND PAPER BOOKS.**

\$1.00 per printed page, net, for all under 100 pages; over 100 pages, 90 cents per page, net.

**DODGERS, HAND-BILLS, PROGRAMMES, ETC.**

ON PRINT AND BOOK PAPER.

**On 3-cent paper (24×36 inches, 30-lb.).**

	100	250	500	1000	ADDED 1000
3 to a sheet, paper \$0.90 per thousand	\$4.50	\$5.00	\$5.50	\$6.75	\$2.40
4 to a sheet, paper .68 per thousand	4.00	4.50	5.00	6.00	2.10
6 to a sheet, paper .45 per thousand	3.25	3.65	4.10	4.90	1.80
8 to a sheet, paper .34 per thousand	2.45	2.75	3.15	3.80	1.40
10 to a sheet, paper .27 per thousand	2.25	2.60	2.85	3.50	1.30
12 to a sheet, paper .23 per thousand	1.90	2.20	2.50	3.10	1.20
16 to a sheet, paper .17 per thousand	1.75	1.95	2.15	2.60	.90
24 to a sheet, paper .12 per thousand	1.20	1.40	1.55	2.00	.70

**On 4-cent paper (24×36 inches, 40-lb.).**

	100	250	500	1000	ADDED 1000
3 to a sheet, paper \$1.60 per thousand	4.60	5.20	5.85	7.00	3.10
4 to a sheet, paper 1.20 per thousand	4.10	4.60	5.55	6.45	2.60
6 to a sheet, paper .80 per thousand	3.35	3.70	4.20	5.35	2.15
8 to a sheet, paper .60 per thousand	2.55	2.80	3.25	4.10	1.70
10 to a sheet, paper .48 per thousand	2.35	2.65	2.95	3.70	1.50
12 to a sheet, paper .40 per thousand	2.00	2.25	2.55	3.25	1.40
16 to a sheet, paper .30 per thousand	1.80	2.00	2.24	2.75	1.05
24 to a sheet, paper .20 per thousand	1.30	1.40	1.60	2.00	.80

The 4c. paper will represent the value of colored prints.

Blue or green ink will add for the first 100 copies \$1.00, and for subsequent 100s, in sizes above sixes, 10c. per 100. On sixes and eights, subsequent 100s at 5c.

Bright red ink will add for the first 100 copies \$1.25, and for subsequent 100s, in sizes above sixes, 20c. per 100. On sixes and eights, subsequent 100s at 10c.

**POSTERS AND SHOW-BILLS.**

Using 40-lb. paper, 28×42 inches, costing 4c., the value of 100 sheets being 50c.

**Whole sheet.**

	100	250	500	1000	ADDED 1000
Black ink . . .	\$5.10	\$6.50	\$ 8.75	\$13.00	\$0.90
Red or blue ink .	6.10	7.75	11.50	16.00	1.10
In two colors . .	7.80	9.90	13.40	20.40	1.40

**Half sheet.**

	100	250	500	1000	ADDED 1000
Black ink . . .	4.30	5.05	6.30	8.80	.50
Red or blue ink .	5.30	6.20	7.70	10.70	.60
In two colors . .	7.00	8.35	10.60	15.00	.90

**Third sheet.**

	100	250	500	1000	ADDED 1000
Black ink . . .	3.70	4.25	5.10	6.85	.35
Red or blue ink .	4.70	5.30	6.30	8.30	.40
In two colors . .	6.20	7.25	8.80	12.00	.65

**Quarter sheet.**

	100	250	500	1000	ADDED 1000
Black ink . . .	3.15	3.60	4.35	5.85	.30
Red or blue ink .	4.15	4.70	5.55	7.30	.35
In two colors . .	5.50	6.35	7.75	10.50	.55

The most effective plain posters are printed on yellow paper, the value of paper being 80c. per 100 full sheets.

On 24×36 paper the difference is so slight, except in large quantities, that the same price should prevail. In 1000 orders a discount of 10 per cent. may be made.

**DELEGATE OR NOMINATION TICKETS.**

For conventions in separate lots of 500.

500	1000	1500	2000	ADDED 1000
\$1.25	\$1.50	\$2.00	\$2.25	\$1.00

**HALF-LETTER OR QUARTER-FOLIO CIRCULARS.**

No form rated at less than \$1.00. The figures in this table are based on 10 Point and \$2.00 for composition. The value of a full page of 12 Point is \$1.50; 10 Point, \$2.00; 8 Point, \$3.00; 6 Point, \$4.00. The difference should be added or deducted from the gross figures.

**20-lb. stock.**

	100	250	500	1000	ADDED 100
8-cent paper, \$1.20 per thousand	\$2.85	\$3.20	\$3.75	\$4.85	\$0.20
10-cent paper, 1.50 per thousand	2.90	3.30	3.90	5.15	.23
12-cent paper, 1.80 per thousand	2.95	3.35	4.05	5.45	.26
14-cent paper, 2.10 per thousand	2.95	3.40	4.20	5.75	.29
16-cent paper, 2.40 per thousand	3.00	3.50	4.35	6.05	.32
18-cent paper, 2.70 per thousand	3.05	3.55	4.50	6.35	.35
20-cent paper, 3.00 per thousand	3.05	3.65	4.65	6.65	.38

24-lb. stock will add for paper for each 1000 copies—on 8c. paper 25c., 10c. paper 31c., 12c. paper 37c., 14c. paper 44c., 16c. paper 50c., 18c. paper 56c., 20c. paper 62c.

Printing front and back, different forms, add for composition and 5c. per 100 additional for presswork.

Figure on 10c. paper and 20-lb. stock, unless requested otherwise.

**FOLDED NOTE CIRCULARS.**

Using quarter sheet demy or folio. The figures are based on 10 Point and \$1.00 for each page of composition. The value of a full page of 12 Point is 75c.; 8 Point, \$1.50; 6 Point, \$2.00. The difference should be added or deducted from the gross figures.

**One page, folded, 20-lb. stock.**

	100	250	500	1000	ADDED 100
8-cent paper, \$1.20 per thousand	\$2.00	\$2.30	\$2.85	\$4.00	\$0.20
10-cent paper, 1.50 per thousand	2.05	2.40	3.00	4.30	.23
12-cent paper, 1.80 per thousand	2.10	2.45	3.15	4.60	.26
14-cent paper, 2.10 per thousand	2.15	2.50	3.30	4.90	.29
16-cent paper, 2.40 per thousand	2.20	2.60	3.45	5.20	.32
18-cent paper, 2.70 per thousand	2.25	2.65	3.60	5.50	.35
20-cent paper, 3.00 per thousand	2.30	2.70	3.75	5.80	.38

**Two pages, folded, 20-lb. stock.**

8-cent paper	2.00	3.30	3.85	5.00	.25
10-cent paper	3.05	3.40	4.00	5.30	.28
12-cent paper	3.10	3.45	4.15	5.60	.31
14-cent paper	3.15	3.50	4.30	5.90	.34
16-cent paper	3.20	3.60	4.45	6.20	.37
18-cent paper	3.25	3.65	4.60	6.50	.40
20-cent paper	3.30	3.70	4.75	6.80	.43

**Three pages, folded, 20-lb. stock.**

8-cent paper	4.00	4.30	4.85	6.00	.25
10-cent paper	4.05	4.40	5.00	6.30	.28
12-cent paper	4.10	4.45	5.15	6.60	.31
14-cent paper	4.15	4.50	5.30	6.90	.34
16-cent paper	4.20	4.60	5.45	7.20	.37
18-cent paper	4.25	4.65	5.60	7.50	.40
20-cent paper	4.30	4.70	5.75	7.70	.43

**Four pages, folded, 20-lb. stock.**

8-cent paper	5.00	5.30	5.85	7.00	.25
10-cent paper	5.05	5.40	6.00	7.30	.28
12-cent paper	5.10	5.45	6.15	7.60	.31
14-cent paper	5.15	5.50	6.30	7.90	.34
16-cent paper	5.20	5.60	6.45	8.20	.37
18-cent paper	5.25	5.65	6.60	8.50	.40
20-cent paper	5.30	5.70	7.75	8.80	.43

For difference in weight of stock, see half-letter or quarter-folio circulars.

The above figures include folding one fold.

Figure on 10c. paper and 20-lb. stock, unless requested otherwise.

**HALF NOTE OR EIGHTH FOLIO CIRCULARS.**

No form rated less than 50c. for composition. The figures in this table are based on 10 Point and \$1.00 for composition. The value of a full page of 12 Point is 75c.; 10 Point, \$1.00; 8 Point, \$1.50; 6 Point, \$2.00. The difference should be added or deducted from the gross figures.

**20-lb. stock.**

	100	250	500	1000	ADDED 100
8-cent paper, \$0.60 per thousand	\$1.65	\$1.90	\$2.20	\$2.90	\$0.12
10-cent paper, .75 per thousand	1.70	2.00	2.30	3.05	.14
12-cent paper, .90 per thousand	1.70	2.05	2.35	3.20	.15
14-cent paper, 1.05 per thousand	1.70	2.10	2.45	3.35	.16
16-cent paper, 1.20 per thousand	1.75	2.10	2.50	3.50	.18
18-cent paper, 1.35 per thousand	1.80	2.10	2.60	3.65	.19
20-cent paper, 1.50 per thousand	1.85	2.15	2.70	3.80	.21

Printing front and back, add for composition only.

24-lb. stock will add for paper for each 1000 copies—on 8c. paper 12c., 10c. paper 15c., 12c. paper 19c., 14c. paper 21c., 16c. paper 25c., 18c. paper 28c., 20c. paper 31c.

**FOLDED LETTER CIRCULARS.**

Using half sheet demy or folio. The figures are based on 10 point and \$2.00 for each page of composition. The value of a full page of 12 Point is \$1.50; 8 Point, \$3.00; 6 Point, \$4.00. The difference should be added or deducted from the gross figures.

**One page, folded, 20-lb. stock.**

	100	250	500	1000	ADDED 100
8-cent paper, \$2.40 per thousand	\$3.25	\$3.90	\$4.80	\$6.75	\$0.37
10-cent paper, 3.00 per thousand	3.30	4.05	5.10	7.35	.43
12-cent paper, 3.60 per thousand	3.35	4.20	5.40	7.95	.49
14-cent paper, 4.20 per thousand	3.40	4.35	5.70	8.55	.55
16-cent paper, 4.80 per thousand	3.45	4.50	6.00	9.15	.61
18-cent paper, 5.40 per thousand	3.50	4.65	6.30	9.75	.67
20-cent paper, 6.00 per thousand	3.55	4.80	6.60	10.35	.73

**Two pages, folded, 20-lb. stock.**

8-cent paper	5.25	5.90	6.80	8.75	.37
10-cent paper	5.30	6.05	7.10	9.35	.43
12-cent paper	5.35	6.20	7.40	9.95	.49
14-cent paper	5.40	6.35	7.70	10.55	.55
16-cent paper	5.45	6.50	8.00	11.15	.61
18-cent paper	5.50	6.65	8.30	11.75	.67
20-cent paper	5.55	6.80	8.60	12.35	.73

**Three pages, folded, 20-lb. stock.**

8-cent paper	7.25	7.90	8.80	10.75	.37
10-cent paper	7.30	8.05	9.10	11.35	.43
12-cent paper	7.35	8.20	9.40	11.95	.49
14-cent paper	7.40	8.35	9.70	12.55	.55
16-cent paper	7.45	8.50	10.00	13.15	.61
18-cent paper	7.50	8.65	10.30	13.75	.67
20-cent paper	7.55	8.80	10.60	14.35	.73

**Four pages, folded, 20-lb. stock.**

8-cent paper	9.25	9.90	10.80	12.75	.37
10-cent paper	9.30	10.05	11.10	13.35	.43
12-cent paper	9.35	10.20	11.40	13.95	.49
14-cent paper	9.40	10.35	11.70	14.55	.55
16-cent paper	9.45	10.50	12.00	15.15	.61
18-cent paper	9.50	10.65	12.30	15.75	.67
20-cent paper	9.55	10.80	12.60	16.35	.73

The above figures include folding one fold.

24-lb. stock will add for paper for each 1000 copies—on 8c. paper 50c., 10c. paper 62c., 12c. paper 75c., 14c. paper 88c., 16c. paper \$1.00, 18c. paper \$1.12, 20c. paper \$1.25.

Figure on 10c. paper and 20-lb. stock, unless requested otherwise.

**CARD SCALE.**

This is the scale referred to in the Price List of Business Cards on opposite page. The scale is based on 22 x 28 inch cardboard.

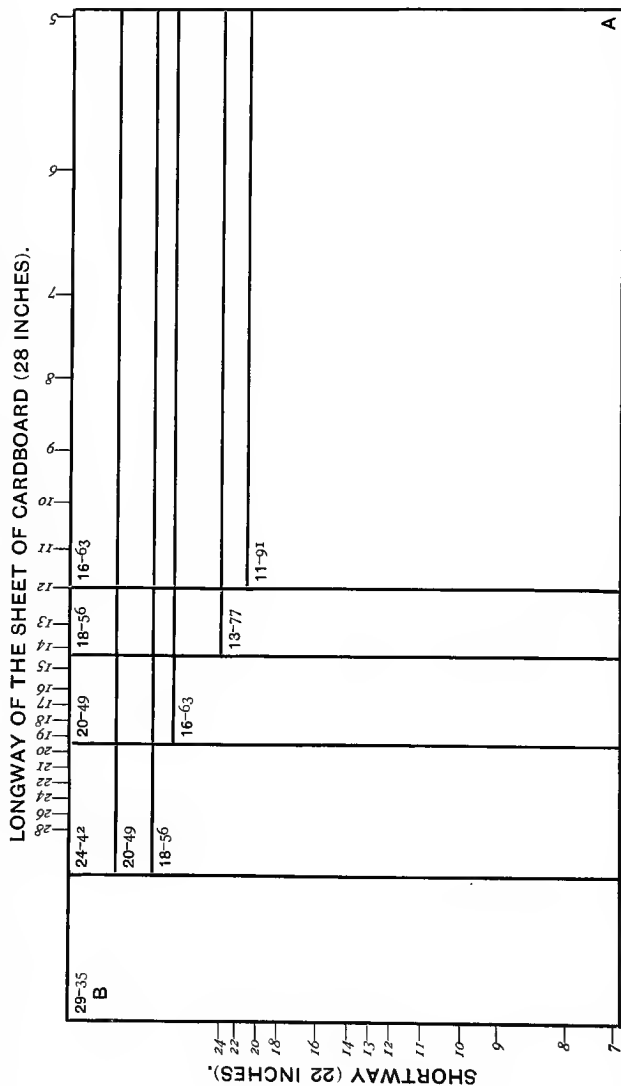

**EXPLANATION.**—The first figures in Gothic in the upper left-hand corner of each size indicate the number of sheets required for 1000 cards of that size. The figures in Roman, after the dash, indicate the number of cards that can be cut from one sheet of cardboard, measuring from the lower right-hand corner of the scale (A).  
The Italic figures outside the scale indicate the number of cuts to a sheet for any size of card not exceeding the size of scale, measuring from the upper left-hand corner (B); and the number of cards procurable from a sheet may be ascertained by multiplying the shortwise and longwise numbers. Example: If a card measures from B longwise to 8 and from B shortwise to 8, the number of cards procurable from one full-sized sheet of 22 x 28 inch card will be 64.

**CARD SCALE.**

The card scale on opposite page agrees approximately with the card scales issued by various dealers in cardboard. There is no standard scale. Printers should procure the card scale of the dealers who supply them with cards. The "Convenient Card Scale and Table of Prices," compiled by Mr. C. F. Pedrick and copyrighted and issued to the trade by Irwin N. Megargee & Co., dealers in cards, 12 S. Sixth St., Philadelphia, will save printers a great deal of time and insure accuracy in estimating. This valuable scale shows at a glance: (1) Cost per 1000 cards of any size after being cut from any kind or quality of board, ranging in list price from \$1.00 to \$15.00 per 100 sheets, 22x28 inches; (2) Which way of the sheet a card of any size will cut to the best advantage; (3) Number of sheets of 22x28 inches cardboard required to cut 1000 cards of any size. This scale is printed on a large sheet of bond paper in two colors, and applicants for it should inclose ten cents in postage stamps.

**BUSINESS CARDS.**

The sizes and figures given for business cards such as 11-91, 50c. stand for 11 full sheets each cutting 91 cards, and the value, including cutting of 1000 of such cards, is 50 cents. On the general rule that all the prices given in these tables have a margin of profit the stock figures represent an addition to the cost of 50 per cent.

**Costing \$1.60 for 100 full sheets.**

	100	250	500	1000	ADDED 100
11-91, \$0.50 per thousand	\$1.00	\$1.20	\$1.50	\$2.00	\$0.11
13-77, .56 per thousand	1.05	1.25	1.60	2.25	.12
16-63, .63 per thousand	1.15	1.40	1.70	2.30	.13
18-56, .68 per thousand	1.20	1.45	1.80	2.50	.14
21-49, .75 per thousand	1.25	1.50	1.85	2.55	.15
24-42, .82 per thousand	1.30	1.60	1.95	2.70	.15
29-35, .95 per thousand	1.40	1.65	2.10	2.85	.16

**Costing \$2.00 for 100 full sheets.**

	100	250	500	1000	ADDED 100
11-91, \$0.58 per thousand	1.00	1.20	1.50	2.10	0.12
13-77, .64 per thousand	1.05	1.25	1.60	2.25	.13
16-63, .75 per thousand	1.15	1.40	1.75	2.45	.14
18-56, .79 per thousand	1.20	1.45	1.85	2.55	.15
21-49, .88 per thousand	1.25	1.60	1.95	2.70	.16
24-42, .97 per thousand	1.30	1.65	2.00	2.80	.16
29-35, 1.12 per thousand	1.40	1.70	2.20	3.10	.18

**Costing \$3.00 for 100 full sheets.**

	100	250	500	1000	ADDED 100
11-91, \$0.75 per thousand	1.15	1.35	1.55	2.25	0.14
13-77, .83 per thousand	1.30	1.55	1.70	2.45	.15
16-63, .97 per thousand	1.45	1.70	1.90	2.75	.16
18-56, 1.01 per thousand	1.45	1.75	1.95	2.85	.17
21-49, 1.25 per thousand	1.45	1.80	2.00	2.95	.18
24-42, 1.33 per thousand	1.75	2.05	2.35	3.35	.20
29-35, 1.55 per thousand	1.75	2.10	2.45	3.60	.22

**Costing \$4.00 for 100 full sheets.**

	100	250	500	1000	ADDED 100
11-91, \$0.91 per thousand	1.20	1.45	1.85	2.65	0.15
13-77, 1.03 per thousand	1.30	1.55	2.00	2.90	.16
16-63, 1.21 per thousand	1.50	1.80	2.30	3.30	.18
18-56, 1.33 per thousand	1.50	1.85	2.35	3.40	.19
21-49, 1.51 per thousand	1.50	1.95	2.40	3.55	.21
24-42, 1.69 per thousand	1.75	2.10	2.60	3.80	.22
29-35, 1.99 per thousand	1.80	2.20	2.90	4.25	.24

Round-corner cards will add 50c. for each 1000, added to the foregoing figures.

For cheap entertainment cards use \$2.00 scale. For business cards use the \$4.00 scale, unless specially requested for another grade.

In colored ink, add 50c. to the gross price for any number under 1000, and 10c. for added 1000. For two forms, two colors, add \$1.00 to the gross price; presswork scale for second form.

Cards, backed with another form on cheap grades, add \$1.00, and print both sides at once. On grades on this page make separate presswork and charge 50c. and presswork scale to gross price.

**BUSINESS CARDS—Continued.**

(See card scale on page 218.)

The finer grades of business cards should be rated somewhat higher than common grades, on account of the extra care in composition and presswork.

**Costing \$5.00 per 100 full sheets.**

	100	250	500	1000	ADDED 100
11—91, \$1.02 per thousand	\$1.30	\$1.60	\$1.80	\$2.70	\$0.16
13—77, 1.17 per thousand	1.30	1.65	2.10	3.10	.18
16—63, 1.39 per thousand	1.50	1.70	2.35	3.45	.20
18—56, 1.54 per thousand	1.50	1.85	2.40	3.55	.21
21—49, 1.76 per thousand	1.55	1.95	2.60	3.90	.24
24—42, 1.98 per thousand	1.80	2.20	3.00	4.40	.26
29—35, 2.75 per thousand	1.85	2.35	3.10	4.70	.29

**Costing \$6.00 per 100 full sheets.**

11—91, \$1.24 per thousand	1.30	1.60	2.00	2.90	.18
13—77, 1.42 per thousand	1.35	1.70	2.25	3.35	.21
16—63, 1.69 per thousand	1.50	1.80	2.45	3.65	.23
18—56, 1.87 per thousand	1.55	1.90	2.60	3.90	.25
21—49, 2.14 per thousand	1.55	2.00	2.70	4.15	.27
24—42, 2.41 per thousand	1.85	2.25	3.15	4.75	.30
29—35, 2.86 per thousand	1.90	2.45	3.35	5.15	.35

**Costing \$7.00 per 100 full sheets.**

11—91, \$1.40 per thousand	1.35	1.85	2.10	3.15	.20
13—77, 1.61 per thousand	1.40	1.90	2.30	3.50	.22
16—63, 1.93 per thousand	1.55	2.00	2.65	4.00	.25
18—56, 2.14 per thousand	1.60	2.10	2.70	4.15	.27
21—49, 2.41 per thousand	1.65	2.20	2.90	4.50	.30
24—42, 2.77 per thousand	1.90	2.50	3.25	5.00	.34
29—35, 3.29 per thousand	2.00	2.50	3.50	5.50	.39

**Costing \$8.00 per 100 full sheets.**

11—91, \$1.57 per thousand	1.35	1.90	2.20	3.30	.22
13—77, 1.81 per thousand	1.45	1.95	2.40	3.70	.24
16—63, 2.17 per thousand	1.60	2.10	2.75	4.25	.28
18—56, 2.41 per thousand	1.65	2.20	2.85	4.45	.30
21—49, 2.77 per thousand	1.70	2.30	3.10	4.70	.34
24—42, 3.13 per thousand	1.95	2.40	3.45	5.25	.37
29—35, 3.73 per thousand	2.10	2.60	3.70	5.75	.43

Above prices to govern professional cards.

In colored ink, add 50c. to the gross price for any number under 1000, and 10c. for added 100. For two forms, two colors, add \$1.00 to the gross price; presswork scale for second form.

Cards backed with another form on cheap grades, add \$1.00, and print both sides at once. On grades on this page make separate presswork and charge 50c. and presswork scale on gross price.

**ANNOUNCEMENT AND WEDDING INVITATIONS.**

Full note, 80-lb., satin wove, with inside and outside envelopes, fine script type.

25 copies, stock \$0.60 . . . . .	\$2.50	100 copies, stock \$2.40 . . . . .	\$5.50
50 copies, stock 1.20 . . . . .	3.50	Added 100 copies . . . . .	4.00
75 copies, stock 1.80 . . . . .	4.50		

**VISITING AND WEDDING CARDS.**

50 cards and printing . . . . .	\$1.00	200 cards and printing . . . . .	\$1.50
100 cards and printing . . . . .	1.25		

**ENGRAVED INVITATIONS AND CARD PLATES.**

25 invitations on full note . . . . .	\$ 9.00	50 cards and plate (name only) . . . . .	\$1.75
50 invitations on full note . . . . .	10.00	100 cards and plate (name only) . . . . .	2.00
75 invitations on full note . . . . .	11.00	Address or additional lines, each . . . . .	.50
100 invitations on full note . . . . .	12.00	100 cards from plate . . . . .	1.25
Additional 100 . . . . .	6.00	Additional 100 . . . . .	.80

**ANNOUNCEMENT CARDS—BARONIAL.**

**Size 25— $3\frac{1}{2} \times 4\frac{3}{8}$  inches—**

	100	250	500	1000	ADDED 100
5-cent stock, \$0.20 per hundred	\$1.75	\$2.00	\$2.65	\$4.00	\$0.26
6-cent stock, .23 per hundred	1.85	2.15	2.90	4.55	.31
7-cent stock, .26 per hundred	1.95	2.20	3.10	4.95	.35
8-cent stock, .30 per hundred	2.00	2.25	3.15	5.05	.36

**Size 36— $4 \times 5$  inches—**

	100	250	500	1000	ADDED 100
5-cent stock, \$0.30 per hundred	1.90	2.25	3.15	5.05	.36
6-cent stock, .35 per hundred	2.00	2.35	3.40	5.55	.41
7-cent stock, .40 per hundred	2.10	2.50	3.65	6.05	.46
8-cent stock, .45 per hundred	2.20	2.60	3.90	6.55	.51

Baronial envelopes, without printing, No. 4, for size 25, cream or white, \$1.60 per 1000; and No. 5, for size 36, at \$2.00 per 1000. Linen XX, No. 4, \$1.80 per 1000, and No. 5, \$2.10 per 1000.

**BALL AND DANCE PROGRAMMES.**

Size  $3\frac{1}{2} \times 4\frac{3}{8}$ , when folded, cuts 16 to a sheet of card stock.

**Value of Completed Work (Four Pages).**

ITEMS.	50	100	200	800
Card stock	\$0.25	\$0.50	\$1.00	\$1.50
Composition	2.40	2.40	2.40	2.40
Presswork and scoring	1.15	1.35	1.60	1.90
Totals	\$3.80	\$4.25	\$5.00	\$5.80
Tassels and stringing	.60	1.00	1.75	2.50
Pencils	.75	1.50	3.00	4.00
Totals	\$5.15	\$6.75	\$9.75	\$12.30

Colored ink will add \$1.00 to any of these prices. In two colors, add \$2.00 to above values.

If you use fancy programmes, increase the price, adding the list value of the programme to be used; the card stock charged for being equal to the expense of inserts and any additional forms of presswork on the programme.

**LARGE CARDS OR POSTER ANNOUNCEMENTS.**

The card stock in the following prices represents a cost value of \$2.50 per 100 full sheets.

**BLACK INK.**

**Card Board 22 x 28—**

	100	250	500	1000	ADDED 100
Eighth sheet, stock \$0.45 per hundred	\$2.95	\$3.75	\$ 5.10	\$ 7.85	\$0.55
Quarter sheet, stock .90 per hundred	3.90	5.40	7.90	12.90	1.00
Third sheet, stock 1.20 per hundred	5.20	7.30	10.80	17.80	1.40
Half sheet, stock 1.75 per hundred	6.25	9.25	14.25	24.25	2.00
Whole sheet, stock 3.50 per hundred	9.50	15.10	24.50	43.25	3.75

If in colored ink, add for first 100, \$1.00, and 5 cents for added 100 up to quarter sheets, and 10 cents for sizes over quarter sheets.

**TWO COLORS OF INK.**

	100	250	500	1000	ADDED 100
Eighth sheet	\$4.50	\$ 5.70	\$ 7.70	\$11.70	\$0.80
Quarter sheet	5.50	7.35	10.50	16.75	1.25
Third sheet	7.00	9.60	14.00	22.75	1.75
Half sheet	8.00	12.50	21.90	33.65	2.35
Whole sheet	12.00	18.30	28.80	49.80	4.20

**BLOTTING PADS.**

	12s	16s	20s
60-lb. stock at \$0.10 per lb., 1,000	$4 \times 9\frac{1}{2}$	$4\frac{3}{4} \times 6$	$3\frac{3}{4} \times 6$
Added 1,000	\$3.95	\$3.55	\$3.30
80-lb. stock at \$0.10 per lb., 1,000	2.35	1.95	1.70
Added 1,000	4.45	3.90	3.60
Enameled blotter, 1,000	2.85	2.30	2.00
Added 1,000	5.90	5.00	4.50
	4.30	3.45	2.90

In colored ink add \$2.00 for any number under 5000. Over 5000, add for colored ink 40c. per 1000.

**BILL HEADS.**

The usual sizes of stock-ruled bill heads are 6s, 4s, 3s and 2s of flat cap. The prices given are for ruled papers, costing the printer the prices named, at the rate per pound. If special ruling is required, the full expense of ruling must be added to the figures, because the grade of paper used would represent the value without ruling.

**8-cent paper.**

	100	250	500	1000	ADDED 100
14-lb., 6s, \$0.56 per thousand .	\$1.55	\$1.75	\$2.05	\$2.65	\$0.12
14-lb., 4s, .84 per thousand .	1.60	1.80	2.15	2.95	.15
14-lb., 3s, 1.12 per thousand .	1.70	1.90	2.35	3.20	.18
14-lb., 2s, 1.68 per thousand .	1.75	2.00	2.65	3.80	.24

**10-cent paper.**

14-lb., 6s, \$0.70 per thousand .	1.55	1.80	2.10	2.80	.14
14-lb., 4s, 1.05 per thousand .	1.60	1.85	2.30	3.15	.17
14-lb., 3s, 1.40 per thousand .	1.65	1.95	2.45	3.50	.21
14-lb., 2s, 2.10 per thousand .	1.70	2.10	2.80	4.20	.28
16-lb., 6s, .80 per thousand .	1.60	1.80	2.15	2.90	.15
16-lb., 4s, 1.20 per thousand .	1.65	1.90	2.35	3.30	.19
16-lb., 3s, 1.60 per thousand .	1.70	2.00	2.55	3.70	.23
16-lb., 2s, 2.40 per thousand .	1.75	2.20	2.95	4.50	.31

**12-cent paper.**

14-lb., 6s, \$0.84 per thousand .	1.60	1.80	2.15	2.95	.15
14-lb., 4s, 1.26 per thousand .	1.65	1.90	2.40	3.35	.20
14-lb., 3s, 1.68 per thousand .	1.70	2.00	2.60	3.80	.24
14-lb., 2s, 2.52 per thousand .	1.75	2.25	3.00	4.60	.32
16-lb., 6s, .96 per thousand .	1.60	1.85	2.25	3.05	.17
16-lb., 4s, 1.44 per thousand .	1.65	1.95	2.45	3.55	.21
16-lb., 3s, 1.92 per thousand .	1.70	2.10	2.70	4.00	.26
16-lb., 2s, 2.88 per thousand .	1.80	2.30	3.20	5.00	.36

**14-cent paper.**

14-lb., 6s, \$1.00 per thousand .	1.60	1.85	2.25	3.10	.17
14-lb., 4s, 1.47 per thousand .	1.65	1.95	2.50	3.55	.22
14-lb., 3s, 1.95 per thousand .	1.70	2.10	2.75	4.05	.27
14-lb., 2s, 2.94 per thousand .	1.80	2.35	3.20	5.05	.36
16-lb., 6s, 1.13 per thousand .	1.60	1.90	2.30	3.20	.18
16-lb., 4s, 1.68 per thousand .	1.65	2.00	2.60	3.80	.24
16-lb., 3s, 2.25 per thousand .	1.75	2.15	2.90	4.35	.30
16-lb., 2s, 3.36 per thousand .	1.85	2.45	3.45	5.45	.41

Assorted 1000s, use the 1000 price for each size, cutting off the right-hand figure, giving the price per 100.

Give the figures for 12c. ruled stock and 14-lb. weight, unless specially requested for other grades.

**MONTHLY STATEMENTS.**

Stock-ruled statements are generally made from 20-lb. or 24-lb. folio, and have various designations. The regular size, 8s of folio, is 5½ × 8½ inches; square statements, 12s of folio, 5½ × 5½ inches; yankee statements, 12s of folio, 3½ × 8½ inches; infant statements, 16s of folio, 4¼ × 5½ inches; and gem statements, 18s of folio, 3½ × 5½ inches.

**10-cent paper, 20-lb. stock.**

	100	250	500	1000	ADDED 100
8s, regular, \$0.75 per thousand .	\$1.25	\$1.70	\$2.00	\$2.75	\$0.14
12s, square or yankee, .50 per thousand .	1.25	1.60	1.85	2.50	.11
16s, infant, .38 per thousand .	1.25	1.50	1.80	2.40	.10
18s, gem, .34 per thousand .	1.25	1.50	1.80	2.35	.09

**10-cent paper, 24-lb. stock.**

8s, regular \$0.90 per thousand .	1.30	1.70	2.05	2.90	.15
12s, square or yankee, .60 per thousand .	1.30	1.60	1.90	2.60	.12
16s, infant, .45 per thousand .	1.30	1.55	1.85	2.45	.11
18s, gem, .40 per thousand .	1.30	1.55	1.80	2.40	.10



MONTHLY STATEMENTS—Continued.

12-cent paper, 20-lb. stock.

8s, regular,	\$0.90 per thousand .	\$1.30	\$1.70	\$2.05	\$2.90	\$0.15
12s, square or yankee,	.60 per thousand .	1.30	1.60	1.90	2.60	.12
16s, infant,	.45 per thousand .	1.30	1.55	1.85	2.45	.11
18s, gem,	.40 per thousand .	1.30	1.55	1.80	2.40	.10

12-cent paper, 24-lb. stock.

8s, regular,	\$1.08 per thousand .	1.35	1.75	2.15	3.10	.17
12s, square or yankee,	.72 per thousand .	1.35	1.65	1.95	2.70	.13
16s, infant,	.54 per thousand .	1.35	1.60	1.90	2.55	.12
18s, gem,	.48 per thousand .	1.35	1.60	1.85	2.50	.11

14-cent paper, 20-lb. stock.

8s, regular,	\$1.05 per thousand .	1.35	1.75	2.15	3.10	.17
12s, square or yankee,	.70 per thousand .	1.35	1.65	1.95	2.70	.13
16s, infant,	.53 per thousand .	1.35	1.60	1.90	2.55	.11
18s, gem,	.47 per thousand .	1.35	1.60	1.85	2.50	.11

14-cent paper, 24-lb. stock.

8s, regular,	\$1.26 per thousand .	1.40	1.80	2.25	3.25	.19
12s, square or yankee,	.84 per thousand .	1.40	1.65	2.00	2.85	.15
16s, infant,	.63 per thousand .	1.40	1.60	1.95	2.65	.12
18s, gem,	.56 per thousand .	1.40	1.60	1.90	2.55	.12

Use 12c. paper and 20-lb. stock, unless specially requested to furnish some other grade.

LETTER HEADS.

Usually printed on quarter-sheet folio, the grades of paper differing very materially; but, with the designation of cost values of the stock, the figures cover all the grades from a cheap writing to a first-class linen paper. The prices are maximum, and may be adjusted by a uniform discount. One-third off prices given here will bring most jobs to about the cost value :

8-cent paper.

		100	250	500	1000	ADDED 100
8-lb. stock,	\$0.96 per thousand .	\$1.25	\$1.85	\$2.25	\$3.05	\$0.17
10-lb. stock,	1.20 per thousand .	1.25	1.90	2.35	3.30	.19
12-lb. stock,	1.44 per thousand .	1.50	1.95	2.45	3.55	.21

10-cent paper.

8-lb. stock,	\$1.20 per thousand .	1.50	1.90	2.35	3.30	.19
10-lb. stock,	1.50 per thousand .	1.50	2.00	2.50	3.60	.22
12-lb. stock,	1.80 per thousand .	1.50	2.05	2.65	3.90	.25

12-cent paper.

8-lb. stock,	\$1.44 per thousand .	1.50	1.95	2.45	3.55	.22
10-lb. stock,	1.80 per thousand .	1.50	2.05	2.65	3.90	.25
12-lb. stock,	2.16 per thousand .	1.50	2.15	2.85	4.15	.29

14-cent paper.

8-lb. stock,	\$1.68 per thousand .	1.50	2.00	2.60	3.80	.24
10-lb. stock,	2.10 per thousand .	1.50	2.10	2.80	4.20	.28
12-lb. stock,	2.52 per thousand .	1.50	2.25	3.00	4.60	.32

16-cent paper.

8-lb. stock,	\$1.92 per thousand .	1.50	2.10	2.70	4.00	.26
10-lb. stock,	2.40 per thousand .	1.50	2.20	2.95	4.50	.31
12-lb. stock,	2.88 per thousand .	1.50	2.30	3.20	5.00	.36

18-cent paper.

8-lb. stock,	\$2.16 per thousand .	1.50	2.15	2.85	4.25	.29
10-lb. stock,	2.70 per thousand .	1.50	2.30	3.10	4.80	.34
12-lb. stock,	3.24 per thousand .	1.50	2.40	3.35	5.35	.39

20-cent paper,

8-lb. stock,	\$2.40 per thousand .	1.50	2.20	2.95	4.50	.31
10-lb. stock,	3.00 per thousand .	1.50	2.35	3.25	5.10	.37
12-lb. stock,	3.60 per thousand .	1.50	2.50	3.55	5.70	.43

Figure on 12c. paper and 10-lb. stock, unless otherwise requested.

NOTE AND MEMORANDUM HEADINGS.

This class of work is usually printed on 8s of folio, either the broad or narrow way. The different values of paper represent the cost to the printer. One-third off the prices given here will bring most jobs to about the cost value :

	100	250	500	1000	ADDED 100
<b>8-cent paper.</b>					
4-lb. stock, \$0.48 per thousand	\$1.25	\$1.75	\$2.00	\$2.60	\$0.12
5-lb. stock, .60 per thousand	1.25	1.75	2.05	2.70	.13
<b>10-cent paper.</b>					
4-lb. stock, \$0.60 per thousand	1.50	1.75	2.05	2.70	.13
5-lb. stock, .75 per thousand	1.50	1.80	2.15	2.85	.15
6-lb. stock, .90 per thousand	1.50	1.85	2.20	3.00	.16
7-lb. stock, 1.05 per thousand	1.50	1.90	2.30	3.15	.17
<b>12-cent paper.</b>					
4-lb. stock, \$0.72 per thousand	1.50	1.80	2.10	2.80	.14
5-lb. stock, .90 per thousand	1.50	1.85	2.20	3.00	.16
6-lb. stock, 1.08 per thousand	1.50	1.90	2.30	3.20	.18
7-lb. stock, 1.26 per thousand	1.50	1.90	2.40	3.35	.20
<b>14-cent paper.</b>					
4-lb. stock, \$0.84 per thousand	1.50	1.80	2.25	2.95	.15
5-lb. stock, 1.05 per thousand	1.50	1.90	2.30	3.15	.18
6-lb. stock, 1.26 per thousand	1.50	1.90	2.40	3.35	.20
7-lb. stock, 1.47 per thousand	1.50	2.00	2.50	3.55	.22
<b>16-cent paper.</b>					
4-lb. stock, \$0.96 per thousand	1.50	1.85	2.25	3.15	.17
5-lb. stock, 1.20 per thousand	1.50	1.90	2.35	3.30	.19
6-lb. stock, 1.44 per thousand	1.50	1.95	2.45	3.55	.22
7-lb. stock, 1.68 per thousand	1.50	2.05	2.60	3.80	.24
<b>18-cent paper.</b>					
4-lb. stock, \$1.08 per thousand	1.50	1.90	2.30	3.20	.18
5-lb. stock, 1.35 per thousand	1.50	1.95	2.45	3.45	.21
6-lb. stock, 1.62 per thousand	1.50	2.00	2.55	3.70	.23
7-lb. stock, 1.89 per thousand	1.50	2.10	2.70	4.00	.26
<b>20-cent paper.</b>					
4-lb. stock, \$1.20 per thousand	1.50	1.90	2.35	3.30	.19
5-lb. stock, 1.50 per thousand	1.50	1.95	2.50	3.60	.22
6-lb. stock, 1.80 per thousand	1.50	2.00	2.65	3.90	.25
7-lb. stock, 2.10 per thousand	1.50	2.15	2.80	4.20	.28

Figure on 12c. paper and 5-lb. stock, unless otherwise requested.

BEER OR MILK TICKETS.

On heavy, tough check, 100 for \$1.00; 500 for \$1.50; 1000 for \$2.00; change of price or quantity in same order, 20c. for each change.

RESTAURANT AND HOTEL BILLS OF FARE.

- Breakfast or supper, 8s of 24-lb. folio post, at 12c.
- 500 copies, \$3.30; 1,000 copies, \$4.50. Added 1,000 copies, \$1.90.
- Dinner bills, same general style, printed on two sides.
- 500 copies, \$4.95; 1,000 copies, \$6.00. Added 1,000 copies, \$2.50.
- Dinner bills, 4 pages, quarter-sheet folio with wine list.
- 500 copies, \$7.50; 1,000 copies, \$9.15. Added 1,000 copies, \$3.60.
- Skeleton bills to be filled in daily.
- 12s of thin card per 1,000, \$5.65. Added 1,000, \$3.30.
- Restaurant bills on 6s of flat cap.
- 500 copies, \$3.00; 1,000 copies, \$4.00. Added 1,000 copies, \$1.80.

**RAMALEY'S PRICE LIST OF PRINTING**

**ENVELOPES.**

In this list of prices there is one-third added to the general net cost price.

**No. 6 Size.**

	100	250	500	1000	ADDED 100
60-lb. No. 1 rag, \$1.60 per thousand	\$1.00	\$1.35	\$1.90	\$3.10	\$0.22
50-lb. No. 1 rag, 1.47 per thousand	1.00	1.35	1.85	2.95	.21
60-lb. No. 2 rag, 1.35 per thousand	1.00	1.30	1.80	2.85	.20
50-lb. No. 2 rag, 1.27 per thousand	1.00	1.25	1.75	2.75	.19
60-lb. No. 1 wood, 1.13 per thousand	1.00	1.25	1.65	2.65	.17
50-lb. No. 1 wood, 1.00 per thousand	1.00	1.20	1.60	2.50	.16
50-lb. manilla, .87 per thousand	1.00	1.20	1.55	2.35	.15
36-lb. manilla, white, 1.00 per thousand	1.00	1.20	1.60	2.50	.16
36-lb. manilla, .73 per thousand	1.00	1.15	1.45	2.25	.13

**No. 6 1/2 Size.**

60-lb. No. 1 rag, 1.80 per thousand	1.00	1.40	2.00	3.30	.24
50-lb. No. 1 rag, 1.53 per thousand	1.00	1.40	1.90	3.00	.21
60-lb. No. 2 rag, 1.53 per thousand	1.00	1.40	1.90	3.00	.21
50-lb. No. 2 rag, 1.33 per thousand	1.00	1.30	1.80	2.90	.20
60-lb. No. 1 wood, 1.27 per thousand	1.00	1.30	1.75	2.80	.19
50-lb. No. 1 wood, 1.07 per thousand	1.00	1.25	1.65	2.60	.17
50-lb. manilla, 1.00 per thousand	1.00	1.25	1.60	2.50	.16
36-lb. manilla, white, 1.07 per thousand	1.00	1.25	1.65	2.60	.17
36-lb. manilla, .80 per thousand	1.00	1.20	1.50	2.30	.14

**No. 10 Size.**

60-lb. No. 1 rag, 2.87 per thousand	1.25	1.70	2.55	4.40	.37
50-lb. No. 1 rag, 2.47 per thousand	1.25	1.65	2.40	3.95	.33
60-lb. No. 2 rag, 2.53 per thousand	1.25	1.65	2.40	4.00	.33
50-lb. No. 2 rag, 2.20 per thousand	1.25	1.55	2.25	3.75	.30
50-lb. manilla, 1.53 per thousand	1.25	1.40	1.90	3.00	.23
36-lb. manilla, 1.27 per thousand	1.00	1.30	1.75	2.80	.21

**No. 11 Size.**

60-lb. No. 1 rag, 3.45 per thousand	1.30	1.85	2.85	5.00	.45
50-lb. No. 1 rag, 3.00 per thousand	1.30	1.70	2.65	4.45	.40

**No. 12 Size.**

60-lb. No. 1 rag, 4.05 per thousand	1.40	2.00	3.15	5.60	.50
50-lb. No. 1 rag, 3.40 per thousand	1.40	1.90	2.90	4.95	.44

**FOR PRINTING ONLY—STOCK FURNISHED.**

500 . . . \$1.25	5,000 . . . \$4.95	10,000 . . . \$ 8.75
1,000 . . . 1.75	6,000 . . . 5.75	15,000 . . . 11.75
2,000 . . . 2.55	7,000 . . . 6.50	20,000 . . . 14.75
3,000 . . . 3.35	8,000 . . . 7.25	25,000 . . . 17.75
4,000 . . . 4.15	9,000 . . . 8.00	

Figure on 50-lb. No. 2 rag for ordinary business, unless otherwise requested. Colored envelopes on same grade.

**DENNISON TAG ENVELOPE.**

FOR SENDING BILLS WITH PACKAGE.

No. 17 P., 6 x 3 1/2, not printed, per thousand . \$3.25	No. 18 P., 7 1/2 x 3 3/8, not printed, per thousand \$4.20
Printed, per thousand . . . . . 4.50	Printed, per thousand . . . . . 5.50

**DENNISON CLASP ENVELOPE.**

OPEN-END XXXX WEIGHT.

Size, 3 3/8 x 6 inches, per thousand . . . \$4.50	Size, 5 1/4 x 8 inches, per thousand . . . \$5.75
Size, 4 x 6 inches, per thousand . . . 4.75	Size, 5 1/2 x 8 1/4 inches, per thousand . . . 6.00
Size, 3 3/8 x 7 inches, per thousand . . . 5.75	Size, 6 x 9 inches, per thousand . . . 6.25
Size, 4 3/8 x 6 3/4 inches, per thousand . . . 5.00	Size, 6 1/4 x 9 1/2 inches, per thousand . . . 6.75
Size, 4 1/8 x 7 1/4 inches, per thousand . . . 5.00	Size, 6 1/2 x 10 inches, per thousand . . . 7.50
Size, 5 x 7 1/2 inches, per thousand . . . 5.50	Size, 7 x 10 1/2 inches, per thousand . . . 8.00

Printing, add \$1.50 per 1000.

### POSTAL CARDS AND STAMPED ENVELOPES.

The customer should supply postal cards and stamped envelopes. When the stock is furnished by office the prices should be net.

#### Postal Cards, printed on one side.

	STOCK FURNISHED BY OFFICE. NET FIGURES.	STOCK FURNISHED BY CUSTOMER.
100 cards . . . . .	. \$2.00	\$1.00
200 cards . . . . .	3.20	1.10
300 cards . . . . .	4.40	1.20
400 cards . . . . .	5.50	1.35
500 cards . . . . .	6.60	1.50
1,000 cards . . . . .	12.50	2.00
Additional 1,000 . . . . .	11.50	1.00

Printing on two sides, add the last column of figures for the second run.

#### Stamped Envelopes, 2-cent postage, white, commercial size.

100 envelopes, \$21.80 per thousand . . . . .	3.40	1.00
200 envelopes, 21.80 per thousand . . . . .	5.80	1.10
300 envelopes, 21.80 per thousand . . . . .	8.00	1.20
400 envelopes, 21.80 per thousand . . . . .	10.40	1.35
500 envelopes, 21.80 per thousand . . . . .	12.80	1.50
1,000 envelopes, 21.80 per thousand . . . . .	24.45	2.00
Additional 1,000 . . . . .	23.80	1.00

#### One-cent postage, manilla, commercial size.

100 envelopes, \$11.08 per thousand . . . . .	2.00	1.00
200 envelopes, 11.08 per thousand . . . . .	3.40	1.10
300 envelopes, 11.08 per thousand . . . . .	4.80	1.20
400 envelopes, 11.08 per thousand . . . . .	6.20	1.35
500 envelopes, 11.08 per thousand . . . . .	7.50	1.50
1,000 envelopes, 11.08 per thousand . . . . .	14.00	2.00
Additional 1,000 . . . . .	12.60	1.00

One-cent postage, white, commercial size, add 8c. per 100 extra to manilla prices for stock furnished by office.

### SHIPPING TAGS.

The following are list prices on Dennison tags, without printing:

SIZE.	N. Y. G.	DEN. E.	STAND- ARD P.	SIZE.	N. Y. G.	DEN. E.	STAND- ARD P.
1 . . . . .	\$.25	\$.40	\$.90	5	\$.50	\$.85	\$1.00
2 . . . . .	.30	.50	1.00	6	.60	1.00	1.90
3 . . . . .	.35	.60	1.20	7	.70	1.15	2.30
4 . . . . .	.40	.70	1.40	8	.80	1.30	2.75

#### COLORED AND LINEN TAGS.

SIZE.	NOVELTY COL.	PAT. COL.	LINEN.	SIZE.	NOVELTY COL.	PAT. COL.	LINEN.
1 . . . . .	\$.75	\$1.25	\$3.00	5	\$1.60	\$2.75	\$6.25
2 . . . . .	.90	1.50	3.75	6	1.90	3.00	7.25
3 . . . . .	1.10	2.00	4.50	7	2.20	3.50	8.50
4 . . . . .	1.30	2.25	5.25	8	2.50	3.75	10.00

Add for printing to any one kind for 1000, \$1.50; for additional 1000s to 4000, 60c. per 1000; 5000 to 10,000, at 60c. per 1000; over 10,000, at 50c. per 1000. Discounts to be figured from the whole amount.

### HOTEL REGISTERS.

Interleaved with blotting-paper without advertisements.

	DEMY OR MEDIUM.
Books of 300 pages without blotters . . . . .	\$9.50
Add for blotters . . . . .	2.00
Total for one book . . . . .	\$11.50
Added books in same order . . . . .	7.80

**RAMALEY'S PRICE LIST OF PRINTING**

**PRINTED DRAFTS AND INDIVIDUAL CHECKS, BOUND.**

Five forms to a half sheet of folio or royal, one book  
Additional books in same order .

500 FORMS.	1000 FORMS.
\$.75	\$10.10
3.30	5.50

These are for numbered and perforated forms.

In books two or three deep, add 50c. for additional binding on each 1000 forms.

The names of drawers inserted where there is more than one order ; charge, 50c. extra for each set of names. Names of drawers in red or other color, \$1.00 extra.

**CUSTOMERS' CHECKS IN SMALL BOOKS.**

**Check Bound Books.—**

	20 BOOKS	10 BOOKS	2 BOOKS
Total for 1,000 checks	OF 50.	OF 100.	OF 500.
Additional 1,000s	. \$ 5.70	\$ 5.30	\$ 4.90
In lots of 5,000, setting two forms .	3.70	3.30	2.90
In lots of 10,000, setting full form .	15.60	14.10	13.00
In additional lots of 10,000 .	27.00	25.00	25.00
	23.00	21.00	21.00

Twelve checks to one sheet of folio, reduce 15c. per 1000 checks, the paper (24-lb. folio) amounting to 75c. ; all other charges the same.

**BANK OR COUNTER CHECKS.**

WITHOUT STUBS, LOOSE OR IN BLOCKS. SMALL, 2¼×7¼ INCHES, 18S FOLIO  
(STOCK, 40C.).

1,000 . . . . .	\$ 2.00	2,000 . . . . .	\$ 3.00	3,000 . . . . .	\$ 4.00
5,000 . . . . .	6.00	10,000 . . . . .	10.00	20,000 . . . . .	19.00
30,000 . . . . .	25.00	40,000 . . . . .	30.00	50,000 . . . . .	35.00

Large, 3½×8½ inches, 8s cap (stock, 50c.).

1,000 . . . . .	\$ 2.50	2,000 . . . . .	\$ 3.65	3,000 . . . . .	\$ 4.95
5,000 . . . . .	7.00	10,000 . . . . .	12.00	20,000 . . . . .	20.00
30,000 . . . . .	27.00	40,000 . . . . .	34.00	50,000 . . . . .	40.00

These prices are for loose checks, or simply glued in bulk at the top. If in blocks of 50, add 30c. per 1000 for the first 1000 and 20c. for subsequent 1000s.

Colored inks will add \$1.00 to the order.

**DEBIT AND CREDIT SLIPS.**

2¼×4¼, 32s folio (stock, 15c.).

1,000 . . . . .	\$ 1.25	2,000 . . . . .	\$ 1.70	3,000 . . . . .	\$ 2.00
5,000 . . . . .	3.00	10,000 . . . . .	5.00	20,000 . . . . .	9.00
30,000 . . . . .	13.00	40,000 . . . . .	17.00	50,000 . . . . .	21.00

3½×4¼, 24s folio (stock, 20c.).

1,000 . . . . .	\$ 1.25	2,000 . . . . .	\$ 1.80	3,000 . . . . .	\$ 2.20
5,000 . . . . .	3.25	10,000 . . . . .	5.50	20,000 . . . . .	10.00
30,000 . . . . .	14.50	40,000 . . . . .	19.00	50,000 . . . . .	23.00

**DEPOSIT TICKETS.**

3½×5½, 20s of 20-lb. folio post at 8c. (paper 25c.).

1,000 . . . . .	\$ 1.50	2,000 . . . . .	\$ 2.00	3,000 . . . . .	\$ 2.50
5,000 . . . . .	3.50	10,000 . . . . .	6.00	20,000 . . . . .	11.00
30,000 . . . . .	16.00	40,000 . . . . .	21.00	50,000 . . . . .	25.00

4½×7, 8s of 12-lb. cap at 8c. (paper 38c.).

1,000 . . . . .	\$ 1.50	2,000 . . . . .	\$ 2.30	3,000 . . . . .	\$ 3.15
5,000 . . . . .	4.25	10,000 . . . . .	7.50	20,000 . . . . .	14.00
30,000 . . . . .	20.00	40,000 . . . . .	26.00	50,000 . . . . .	31.00

**CERTIFICATES OF DEPOSIT.**

PRINTED TWO ON A LEAF OF FOLDED HALF ROYAL.

Printed two forms on a leaf, using bond paper .  
Additional books in same order .

500 FORMS.	1000 FORMS.
\$.75	\$10.00
3.60	7.00

NOTICES OF NOTES AND ACCEPTANCES.

3½ × 5½, 20s of 20-lb. folio post (paper 30c.).

1,000 . . . . .	\$ 1.50	2,000 . . . . .	\$ 2.40	3,000 . . . . .	\$ 3.30
5,000 . . . . .	4.20	10,000 . . . . .	8.00	20,000 . . . . .	15.00
30,000 . . . . .	21.00	40,000 . . . . .	26.00	50,000 . . . . .	30.00

BONDS AND COUPONS.

Township, school district, village and city bonds.	25 COPIES.	50 COPIES.	100 COPIES.
Bond with 10 coupons . . . . .	\$ 8.75	\$ 8.95	\$ 9.40
Additional 100 copies, \$2.40.			
Full sheet cap bond with 20 coupons	14.00	15.00	16.00
Additional 100 copies, \$3.30.			

RULED AND PRINTED BLANKS.

<b>Double Cap</b> (32-lb. paper, \$1.20 per hundred; ruling, \$2.50).	100 COPIES.	ADDED 100.
One form on a sheet, one side . . . . .	\$7.10	\$1.50
Same, backed with one fold . . . . .	9.10	1.65
Backed with same form . . . . .	7.35	1.90
Two forms on a sheet, one side . . . . .	7.35	1.65
Three forms on a sheet, one side . . . . .	7.55	1.95
Four forms on a sheet, one side, setting two . . . . .	9.30	1.80
Side lines of figures, etc., adjusted to ruled lines, will add \$2.00 to first 100 copies.		
<b>Folio Post</b> (24-lb. paper, 90c. per hundred; ruling, \$2.50).		
One form on a sheet . . . . .	6.00	1.25
Same, backed with one fold . . . . .	8.25	1.30
Backed with same form . . . . .	6.30	1.60
Two forms on a sheet, one side . . . . .	6.25	1.50
Three forms on a sheet . . . . .	6.50	1.70
Four forms on a sheet . . . . .	7.65	1.50
Side lines of figures, etc., adjusted to ruled lines, will add \$2.00 to first 100 copies.		
<b>Cap</b> (16-lb. paper, 60c. per hundred; ruling, \$2.00).		
One form on a sheet . . . . .	4.70	.80
Same, backed with one fold . . . . .	6.35	.90
Backed with same form . . . . .	4.90	1.05
Two forms on a sheet, one side, setting two . . . . .	5.80	.90
Three forms on a sheet, setting three . . . . .	7.00	1.00
Four forms on a sheet . . . . .	6.10	1.15
<b>Half-Sheet Folio</b> (24-lb. paper, 45c. per hundred; ruling, \$1.50).		
One form on a sheet, one side . . . . .	4.45	.75
Same, backed, with one fold . . . . .	6.20	.90
Backed with same form . . . . .	4.70	.90
Two forms on a sheet, one side, setting two . . . . .	5.65	.75
Three forms on a sheet, one side, setting three . . . . .	6.65	.75
Four forms on a sheet, one side, setting four . . . . .	7.65	.75
Side lines of figures adjusted to ruled lines will add \$1.50 to first 100 copies.		
<b>Half-Sheet of Cap</b> (16-lb. paper, 30c. per hundred; ruling, \$1.00).		
One form on a sheet . . . . .	4.10	.55
Same, backed, with one fold . . . . .	5.85	.65
Backed with same form . . . . .	4.30	.65
Two forms on a sheet, one side, setting two . . . . .	5.50	.60
Three forms on a sheet, setting three . . . . .	6.50	.60
Four forms on a sheet, setting four . . . . .	7.50	.60
<b>Quarter-Sheet Folio</b> (24-lb. paper, 23c. per hundred).		
One form on a sheet . . . . .	3.95	.50
Backed, with one fold . . . . .	5.50	.40
Backed with same form . . . . .	4.15	.60
<b>Quarter-Sheet Cap</b> (16-lb. paper, 15c. per hundred; ruling, \$1.00).		
One form on a sheet, one side . . . . .	3.75	.40
Same, backed, with one fold . . . . .	5.50	.40
Backed with same form . . . . .	3.95	.50
<b>Eighth Sheet of Folio</b> (24-lb. paper, 12c. per hundred).		
One form on a sheet, one side . . . . .	3.45	.30
Backed, one fold . . . . .	4.50	.35
Same form on both sides . . . . .	3.60	.35
Blanks without ruling, omit prices for ruling as given above.		

**BANKERS' DEPOSIT BOOKS.**

With printing on cover and on second and third pages inside.

Press or tag-board covers, $3\frac{3}{4} \times 5\frac{1}{2}$ inches.	FIRST 100	ADDED 100
6 leaves	\$3.50	\$2.00
12 leaves	4.50	3.00
24 leaves	5.50	4.00
Press or tag-board covers, $4\frac{1}{4} \times 6\frac{3}{4}$ inches.		
12 leaves	5.00	3.40
24 leaves	6.00	4.50
Leather covers, $3\frac{3}{4} \times 5\frac{1}{2}$ inches.		
24 leaves	10.00	8.00
Leather covers, $4\frac{1}{4} \times 6\frac{3}{4}$ inches.		
24 leaves	14.00	9.00
Leather covers, $3\frac{3}{4} \times 7\frac{3}{4}$ inches.		
24 leaves	14.00	9.00

Interleaved books—the large sizes will be \$3.00 extra for each 100 books.

**BLANK BOOKS.**

In handling blank books, printers should abandon the quire figuring of 80 pages, and substitute 100 pages.

Half binding may be either tight or loose smooth back, with paper or cloth sides and leather corners, usually colored leather.

Three-quarter binding is first-class in every respect as to stock, usually russia back and corners, finished with raised cords or hubs and cloth sides.

Full end and band binding and extra russia ends and bands, full gilt back, are well-known to the trade and need not be described. The figures here submitted are for the best of their class as to binding.

**FLAT CAP. 18-LB. WESTON OR BROWN.**

<b>Books of 400 pages—5 quires.</b>	HALF BINDING.	THREE- QUARTER.	FULL E. & B.	EXTRA RUSSIA.
Ledgers, journals and blank books—paper, \$1.25; ruling, \$2.00 .	\$5.20	\$5.90	\$8.20	\$9.70
Added books in same order .	3.50	4.20	6.50	8.00
Added 100 pages . . . . .	.50	.50	.50	.50
Books with printed headings—ruling, \$2.50; composition, \$2.00; presswork, \$1.30 . . . . .	9.00	9.70	12.00	13.50
Added books in same order . . . . .	3.90	4.60	6.90	8.40
Added 100 pages . . . . .	.60	.60	.60	.60
Books with full-page printing; border ruling, \$1.50; composition, \$3.00; presswork, \$1.50 . . . . .	9.35	10.05	12.35	13.85
Added books in same order . . . . .	3.80	4.50	6.80	8.30
Added 100 pages . . . . .	.65	.65	.65	.65

If two pages are printed full, add \$1.50 to each book.

Omitting border on full-page printed books will take off \$1.50 from first book and 20c. from additional books.

For less number of pages, use the same figures as for additional 100 pages.

20-lb. best ledger will add 10c. for each 100 pages.

Index in front, add \$1.25 to each book, including paper. Index through, add \$2.00 to each book. Canvas cover, add \$1.00.

Printed numbered lines down one page, add \$1.00 to first book; and if on both pages, add \$2.00 for first book.

Patent back, \$1.25 extra.

All additions to be added to gross figures.

**DEMY. 28-LB. WESTON OR BROWN.**

**Books of 400 pages—5 quires.**

	HALF BINDING.	THREE- QUARTER.	FULL E. & B.	EXTRA RUSSIA.
Ledgers, journals and blank books—paper, \$2.15; ruling, \$1.55 .	\$6.15	\$8.05	\$9.45	\$10.90
Added books in same order	4.40	6.30	7.70	9.15
Added 100 pages .	.80	.80	.80	.80
Books with printed headings—ruling, \$2.50; composition, \$2.00; presswork, 1.30 .	10.10	12.00	13.40	14.85
Added books in same order	5.00	6.90	8.30	9.75
Added 100 pages .	.90	.90	.90	.90
Books with full-page printing—border ruling, \$1.50; composition, 4.00; presswork, \$1.50 .	11.15	13.05	14.45	15.90
Added books in same order	5.00	6.90	8.30	9.75
Added 100 pages .	.90	.90	.90	.90

If two pages are printed full, add \$1.50 to each book.

Omitting border on full-page printed books will take off \$1.50 from first book and 40c. from additional books.

For less number of pages, use the same figures as for additional 100 pages.

30-lb. best ledger will add 10c. for each 100 pages.

Index in front, add \$1.50 to each book, including paper. Index through, add \$2.00 to each book. Canvas cover, add \$1.25. Patent back, \$1.50 extra.

Printed numbered lines down one page, add \$1.50 to first book; and if on both pages, add \$2.50 for first book.

All additions to be added to gross figures.

**MEDIUM. 36-LB. WESTON OR BROWN.**

**Books of 400 pages—5 quires.**

	HALF BINDING.	THREE- QUARTER.	FULL E. & B.	EXTRA RUSSIA.
Ledgers, journals and blank books—paper, \$3.00; ruling, \$2.75 .	\$8.25	\$10.35	\$11.85	\$12.45
Added books in same order	5.85	7.85	9.35	10.95
Added 100 pages .	1.15	1.15	1.15	1.15
Books with printed headings—ruling, \$2.75; composition, \$3.00; presswork, \$1.75 .	12.90	15.00	16.50	18.10
Added books in same order	6.55	8.65	10.15	11.35
Added 100 pages .	1.25	1.25	1.25	1.25
Books with full-page printing—border, \$1.75; composition, \$5.00; presswork, \$2.00 .	13.40	15.50	17.00	18.60
Added books in same order	6.55	8.65	10.15	11.35
Added 100 pages .	1.25	1.25	1.25	1.25

If two pages are printed full, add \$2.00 to each book.

Omitting border on full-page printed books will take off \$1.75 from first book and 40c. from additional books.

For less number of pages, use the same figures as for additional 100 pages.

40-lb. best ledger will add 20c. for each 100 pages.

Index in front, add \$1.50 to each book, including paper. Index through, add \$2.00 to each book. Canvas cover, add \$1.50. Patent backs, \$2.00 extra.

Printed numbered lines down one page, add \$2.00 to first book; and if on both pages add \$3.00 for first book.

All additions to be added to gross figures.

**DOUBLE CAP. 36-LB. WESTON OR BROWN.**

**Books of 400 pages—5 quires.**

	HALF BINDING.	THREE- QUARTER.	FULL E. & B.	EXTRA RUSSIA.
Ledgers, journals and blank books—paper, \$2.50; ruling, \$2.75 .	\$8.00	\$10.20	\$11.70	\$13.95
Added books in same order	6.10	8.30	9.80	12.05
Added 100 pages .	1.05	1.05	1.05	1.05
Books with printed headings—ruling, \$2.75; composition, \$4.00; presswork, \$1.75 .	13.65	14.85	17.35	19.60
Added books in same order	6.70	8.90	10.40	12.65
Added 100 pages .	1.15	1.15	1.15	1.15
Books with full-page printing—ruling, \$2.00; composition, \$6.00; presswork, \$2.00 .	14.90	17.10	18.60	20.85
Added books in same order	6.90	9.10	10.60	12.85
Added 100 pages .	1.20	1.20	1.20	1.20



**RAMALEY'S PRICE LIST OF PRINTING**

If two pages are printed full, add \$2.00 to each book.

Omitting border on full-page printed books will take off \$2.00 from first book and 40c. from additional books.

For less number of pages, use the same figures as for additional 100 pages.

40-lb. best ledger will add 15c. for each 100 pages.

Index in front, add \$1.50 to each book, including paper. Index through, add \$2.00 to each book. Canvas cover, add \$2.00. Patent back, \$2.00 extra.

Printed numbered lines down one page, add \$2.00 to first book; and if on both pages, add \$3.00 for first book.

All additions to be added to gross figures.

**ROYAL. 44-LB. WESTON OR BROWN.**

Use double cap table, and add \$1.20 to each book of 400 pages, and 30c. for added 100 pages.

**SUPER-ROYAL. 54-LB. WESTON OR BROWN.**

**Books of 400 pages—5 quires.**

	HALF BINDING.	THREE- QUARTER.	FULL, E. & B.	EXTRA RUSSIA.
Ledgers, journals and blank books—paper, \$5.00; ruling, \$3.50	\$11.10	\$13.50	\$15.20	\$17.65
Added books in same order . . . . .	8.60	11.00	12.70	15.15
Added 100 pages . . . . .	1.70	1.70	1.70	1.70
Books with printed headings—ruling, \$3.50; composition, \$5.00; presswork, \$2.00 . . . . .	18.10	20.50	22.20	24.65
Added books in same order . . . . .	9.40	11.80	13.50	15.95
Added 100 pages . . . . .	1.90	1.90	1.90	1.90
Books with full-page printing—ruling, \$3.50; composition, \$9.00; presswork, \$3.00 . . . . .	23.10	25.50	27.20	29.65
Added books in same order . . . . .	9.60	12.00	13.70	16.15
Added 100 pages . . . . .	2.00	2.00	2.00	2.00

If two pages are printed full, add \$3.00 to each book.

Omitting border on full-page printed books will take off \$3.50 from first book and 50c. from additional books.

For less number of pages, use the same figures as for additional 100 pages.

Index in front, add \$2.00 to each book, including paper. Index through, add \$2.00 to each book. Canvas cover, add \$3.00. Patent back, \$2.50 extra.

Printed numbered lines down one page, add \$2.00 to first book; and if on both pages, add \$3.00 for first book.

All additions to be added to gross figures.

**DOUBLE DEMY. 56-LB. WESTON OR BROWN.**

**Books of 400 pages—5 quires.**

	HALF BINDING.	THREE- QUARTER.	FULL E. & B.	EXTRA RUSSIA.
Ledgers, journals and blank books—paper, \$4.25; ruling, \$3.50	\$11.35	\$14.35	\$16.45	\$19.55
Added books in same order . . . . .	8.50	11.50	13.60	16.70
Added 100 pages . . . . .	1.55	1.55	1.55	1.55
Books with printed headings—ruling, \$3.50; composition, \$5.00; presswork, \$2.00 . . . . .	18.35	21.35	23.45	26.55
Added books in same order . . . . .	9.10	12.10	14.20	17.30
Added 100 pages . . . . .	1.70	1.70	1.70	1.70
Books with full-page printing—ruling, \$3.50; composition, \$9.00; presswork, \$3.00 . . . . .	25.35	29.35	31.45	34.55
Added books in same order . . . . .	9.30	12.30	14.40	17.50
Added 100 pages . . . . .	1.80	1.80	1.80	1.80

If two pages are printed full, add \$3.00 to each book.

Omitting border on full-page printed books will take off \$3.50 from first book and 50c. from additional books.

For less number of pages, use the same figures as for additional 100 pages.

Index in front, add \$2.00 to each book, including paper. Index through, add \$2.00 to each book. Canvas cover, add \$3.00. Patent back, \$2.50 extra.

Printed numbered lines down one page, add \$2.00 to first book; and if on both pages, add \$3.00 for first book.

All additions to be added to gross figures.

**DOUBLE MEDIUM. 72-LB. WESTON OR BROWN.**

**Books of 400 pages—5 quires.**

	HALF BINDING.	THREE QUARTER.	FULL E. & B.	EXTRA RUSSIA.
Ledgers, journals and blank books—paper, \$6.00; ruling, \$4.00	\$13.90	\$17.50	\$20.00	\$23.75
Added books in same order . . . . .	10.90	14.50	17.00	20.75
Added 100 pages . . . . .	2.00	2.00	2.00	2.00
Books with printed headings—ruling, \$4.00; composition, \$6.00; presswork, \$2.00 . . . . .	21.90	25.50	28.00	31.75
Added books in same order . . . . .	11.50	15.10	17.60	21.35
Added 100 pages . . . . .	2.20	2.20	2.20	2.20
Books with full-page printing—ruling, \$3.50; composition, \$10.00; presswork, \$3.00 . . . . .	26.40	30.00	32.50	36.25
Added books in same order . . . . .	11.70	15.30	17.80	21.55
Added 100 pages . . . . .	2.30	2.30	2.30	2.30

If two pages are printed full, add \$3.00 to each book.

Omitting border on full-page printed books will take off \$3.50 from first book and 50c. from additional books.

For less number of pages, use the same figures as for additional 100 pages.

Index in front, add \$2.50 to each book, including paper. Index through, add \$2.00 to each book. Canvas cover, add \$3.50. Patent back, \$2.50 extra.

Printed numbered lines down one page, add \$2.00 to first book; and if on both pages, add \$3.00 for first book.

All additions to be added to gross figures.

**BLANK BOOKS WITH STUBS OR DUPLICATES.**

PRINTED, NUMBERED, PERFORATED AND BOUND.

**Half-Bound, Double Cap (32-lb. \$1.20).**

	ONE BOOK 100 LEAVES.	ADDED 100 LEAVES IN SAME BOOK.
Two forms on a full sheet; composition, \$6.00, setting one.		
In duplicate, 200 forms . . . . .	\$12.50	\$2.10
Additional books . . . . .	4.90	2.10
Three forms on a full sheet; composition, \$4.00, setting one.		
In duplicate, 300 forms . . . . .	10.85	2.45
Additional books . . . . .	5.25	2.45
Four forms on a full sheet; composition, \$6.00, setting two.		
In duplicate, 400 forms . . . . .	12.90	2.50
Additional books . . . . .	5.30	2.50

**Half-Bound, Folio Post (24-lb. 90c.).**

Two forms on a full sheet; composition, \$4.00, setting one.		
In duplicate, 200 forms . . . . .	8.40	1.80
Additional books . . . . .	3.30	1.80
Three forms on a full sheet; composition, \$3.00, setting one.		
In duplicate, 300 forms . . . . .	7.75	2.15
Additional books . . . . .	3.65	2.15
Four forms on a full sheet; composition, \$4.00, setting two.		
In duplicate, 400 forms . . . . .	8.80	2.20
Additional books . . . . .	3.70	2.20
Five forms on a full sheet.		
In duplicate, 500 forms . . . . .	10.00	2.40
Additional books . . . . .	3.90	2.40
Six forms on a full sheet.		
In duplicate, 600 forms . . . . .	10.20	2.50
Additional books . . . . .	4.10	2.50

**Half-Bound, Flat Cap (16-lb., 60c.).**

Two forms on a full sheet; composition, \$3.00, setting one.		
In duplicate, 200 forms . . . . .	7.40	1.50
Additional books . . . . .	2.80	1.50
Three forms on a full sheet; composition, \$2.00, setting one.		
In duplicate, 300 forms . . . . .	6.75	1.85
Additional books . . . . .	3.15	1.85
Four forms on a full sheet; composition, \$3.00, setting two.		
In duplicate, 400 forms . . . . .	7.80	1.90
Additional books . . . . .	3.20	1.90
Five forms on a full sheet.		
In duplicate, 500 forms . . . . .	9.00	2.10
Additional books . . . . .	3.40	2.10

**BLANK BOOKS WITH STUBS AND DUPLICATES.**

PRINTED, NUMBERED, PERFORATED AND BOUND—*Continued.*

**Half-Bound, Half-Folio Post (24-lb., 45c.).**

	ONE BOOK 100 LEAVES.	ADDED 100 LEAVES IN SAME BOOK.
Two forms on a half sheet ; composition, \$2.50, setting one.		
In duplicate, 200 forms	\$6.05	\$1.35
Additional books	2.45	1.35
Three forms on a half sheet ; composition, \$2.00, setting one.		
In duplicate, 300 forms	5.90	1.70
Additional books	2.80	1.70
Four forms on a half sheet ; composition, \$2.50, setting two.		
In duplicate, 400 forms	6.45	1.75
Additional books	2.85	1.75
Five forms on a half sheet ; composition, \$3.50, setting three.		
In duplicate, 500 forms	7.90	2.20
Additional books	3.30	2.20
Six forms on a half sheet ; composition, \$3.50, setting three.		
In duplicate, 600 forms	7.85	2.05
Additional books	3.15	2.05

**Half-Bound, Half Cap (16-lb., 30c.).**

One form in duplicate	6.00	.80
Additional books	1.90	.80
Two forms on a half-sheet.		
In duplicate, 200 forms	6.70	1.00
Additional books	2.10	1.00
Three forms on a half sheet.		
In duplicate, 300 forms	6.90	1.20
Additional books	2.30	1.20
Four forms on a half sheet.		
In duplicate, 400 forms	7.10	1.30
Additional books	2.50	1.30
Five forms on a half sheet.		
In duplicate, 500 forms	7.30	1.40
Additional books	2.70	1.40

**Half-Bound, Quarter-Sheet Folio (24-lb., 23c.).**

One form on a quarter sheet.		
In duplicate, 100 forms	5.90	.75
Additional books	1.80	.75
Two forms on a quarter sheet.		
In duplicate, 200 forms	6.60	.90
Additional books	2.00	.90
Three forms on a quarter sheet.		
In duplicate, 300 forms	6.80	1.15
Additional books	2.20	1.15

**Half-Bound, Quarter-Sheet Cap (16-lb., 15c.).**

Long form on a quarter sheet.		
In duplicate, 100 forms	4.10	.60
Additional books	1.20	.60
Without perforating or numbering	3.65	.40
Additional books	1.00	.40
One form on a quarter sheet.		
In duplicate, 100 forms	4.60	.55
Additional books	1.50	.55
Two forms on a quarter sheet.		
In duplicate, 200 forms	4.80	.75
Additional books	1.65	.75

Triplicate forms, add for extra numbers and perforations on each book of 100 forms, 15 cents ; 200 forms, 20 cents ; 300 forms, 25 cents ; 400 forms, 30 cents ; 500 forms, 35 cents ; 600 forms, 40 cents.

Check binding will reduce the figures on any one book \$1.00. Duck binding will reduce the figures on any one book 50c.

If not numbered, reduce 10c. for every 100 forms.

**COMMISSIONS SALES ACCOUNTS.**

On 4s of 16-lb. cap, at 12c. ; ruled to order.  
 100 copies, \$3.50 ; 1,000 copies, \$5.10. Added 1,000 copies, \$2.60.

On 4s of 24-lb. folio, at 12c. ; ruled to order.  
 100 copies, \$2.70 ; 500 copies, \$4.10 ; 1,000 copies, \$6.00. Added 1,000 copies, \$3.60.

**GUARD BOOKS OR PLAT BOOKS.**

Quarter medium, 150 leaves, mauilla paper, half-bound, paper sides, \$2.50.  
 Half medium, 200 leaves, \$3.00.  
 Full medium size, 200 leaves, \$5.00.  
 Large sizes, \$6.00 to \$10.00.

**NUMBERING AND PERFORATING.**

Consecutive numbering on cards, checks, deposit certificates, etc. .  
 500 numbers . . . . . \$0.40 | 1,000 numbers . . . . . \$0.50  
 Over 1000 numbers, 50c. per 1000.  
 Perforating in small quantities :  
 100 perforations . . . . . \$0.20 | 1,000 perforations . . . . . \$0.50  
 500 perforations . . . . . 40 | Over 1,000, per thousand . . . . . 50

**BINDING BLANK BOOKS WITHOUT THE RULING, PRINTING OR PAPER COUNTED IN.**

400 pages—5 quires.	HALF BDG.	THREE QUARTERS.	FULL E. & B.	EXTRA E. & B.
Flat cap . . . . .	\$1.60	\$2.30	\$4.60	\$6.10
Added 100 pages . . . . .	.10	.10	.10	.10
Demy . . . . .	1.80	3.70	5.10	6.55
Added 100 pages . . . . .	.15	.15	.15	.15
Medium . . . . .	2.15	4.25	5.75	7.35
Added 100 pages . . . . .	.20	.20	.20	.20
Royal and double cap . . . . .	2.40	4.60	6.10	8.35
Added 100 pages . . . . .	.25	.25	.25	.25
Super royal . . . . .	2.60	5.00	6.70	9.15
Added 100 pages . . . . .	.25	.25	.25	.25
Double demy . . . . .	3.25	6.25	8.35	11.45
Added 100 pages . . . . .	.25	.25	.25	.25
Double medium . . . . .	3.90	7.50	10.00	13.75
Added 100 pages . . . . .	.25	.25	.25	.25

**RULING ON BLANKS.**

Demy or smaller, under 20 down pens.	100	250	500	1000	ADDED 100
One run . . . . .	\$0.90	\$1.00	\$1.10	\$1.10	\$0.05
Two runs . . . . .	1.50	1.70	2.00	2.50	.08
Three runs . . . . .	2.00	2.25	2.75	3.25	.12
Four runs . . . . .	2.50	2.80	3.30	4.00	.15
Double cap or smaller, under 40 down pens.					
One run . . . . .	1.00	1.25	1.60	2.00	.06
Two runs . . . . .	1.80	2.10	2.50	3.10	.12
Three runs . . . . .	2.50	2.85	3.50	4.25	.15
Four runs . . . . .	3.00	3.50	4.10	5.00	.18
Double demy or smaller, under 60 down pens.					
One run . . . . .	1.50	2.00	2.75	3.25	.08
Two runs . . . . .	2.25	2.75	3.50	4.25	.16
Three runs . . . . .	3.00	3.50	4.25	5.25	.20
Four runs . . . . .	3.75	4.25	5.00	6.25	.25
Double medium or smaller, under 80 down pens.					
One run . . . . .	2.00	2.50	3.00	3.75	.10
Two runs . . . . .	3.00	3.50	4.00	5.00	.20
Three runs . . . . .	4.00	4.50	5.00	6.25	.25
Four runs . . . . .	5.00	5.50	6.00	7.50	.30

**RAMALEY'S PRICE LIST OF PRINTING**

**JOB BINDING, WITHOUT NUMBERING AND PERFORATING.**

**Quarter cap or up to 4 x 12.**

Single books of 100 leaves or less . . . . .	CHECK.	DUCK.	HF. BOO.
Additional books in same order . . . . .	\$.05	\$.40	\$.75
Twenty books or over, per book . . . . .	.10	.30	.65
Books of 50 leaves only, in orders over 20, per book . . . . .	.10	.25	.60
	.08	.20	.50

**Quarter folio or up to 5 1/2 x 17.**

Single books of 100 leaves or less . . . . .	.25	.50	.90
Additional books in same order . . . . .	.20	.40	.80
Twenty books or over, per book . . . . .	.15	.35	.75
Single books of 200 leaves, or over 100 leaves . . . . .	.30	.60	1.00
Additional books in same order . . . . .	.25	.50	.90
Twenty books or over, per book . . . . .	.20	.40	.80

**Half sheet cap or up to 5 1/3 x 22.**

Single books of 100 leaves or less . . . . .	.30	.60	1.10
Additional books in same order . . . . .	.25	.50	.90
Twenty books or over, per book . . . . .	.20	.40	.80
Single books of 200 leaves, or over 100 leaves . . . . .	.35	.65	1.10
Additional books in same order . . . . .	.30	.55	1.00
Twenty books or over, per book . . . . .	.25	.40	.90

**Half sheet folio, demy or medium, either way.**

Single books of 100 leaves or less . . . . .	.40	.70	1.10
Additional books in same order . . . . .	.30	.60	1.00
Twenty books or over, per book . . . . .	.25	.45	.75
Single books of 200 leaves, or over 100 leaves . . . . .	.45	.75	1.15
Additional books in same order . . . . .	.35	.65	1.05
Twenty books or over, per book . . . . .	.30	.50	.80

**Full sheet cap, not folded.**

Single books of 100 leaves or less . . . . .	.45	.7	1.15
Additional books in same order . . . . .	.35	.65	1.05
Twenty books or over, per book . . . . .	.30	.50	.80
Single books of 200 leaves, or over 100 leaves . . . . .	.50	.80	1.20
Additional books in same order . . . . .	.40	.70	1.10
Twenty books or over, per book . . . . .	.35	.55	.85

**Perforating, 50c. per 1000 perforations.**

**Numbering, 50c. per 1000 numbers.**

**PAMPHLET BINDING.**

	WITHOUT COVER.		WITH COVER.	
	SADDLE STITCH.	SIDE STITCH.	SADDLE STITCH.	SIDE STITCH.
8 pages, 1 form, per thousand copies . . . . .	\$1.30	\$1.60	\$2.00	\$3.80
12 pages, 1 form, per thousand copies . . . . .	1.40	1.70	2.20	4.00
16 pages, 1 form, per thousand copies . . . . .	1.50	1.80	2.20	4.00
16 pages, 2 forms, per thousand copies . . . . .	1.75	2.00	2.50	4.30
24 pages, 2 forms, per thousand copies . . . . .	2.00	2.30	2.75	4.50
24 pages, 3 forms, per thousand copies . . . . .	2.25	2.60	3.00	4.80
32 pages, 1 form, per thousand copies . . . . .	2.00	2.30	2.50	4.50
32 pages, 2 forms, per thousand copies . . . . .	2.25	2.60	3.00	4.80
	WITH COVER.	SIDE STITCH.	WITH COVER.	
			SIDE STITCH.	
32 pages, 3 forms, per thousand copies . . . . .	\$5.00		56 pages, 4 forms, per thousand copies . . . . .	\$5.75
32 pages, 4 forms, per thousand copies . . . . .	5.00		56 pages, 5 forms, per thousand copies . . . . .	6.00
40 pages, 2 forms, per thousand copies . . . . .	4.75		56 pages, 6 forms, per thousand copies . . . . .	6.25
40 pages, 3 forms, per thousand copies . . . . .	5.00		56 pages, 7 forms, per thousand copies . . . . .	6.50
40 pages, 4 forms, per thousand copies . . . . .	5.25		64 pages, 2 forms, per thousand copies . . . . .	5.50
40 pages, 5 forms, per thousand copies . . . . .	5.50		64 pages, 3 forms, per thousand copies . . . . .	5.75
48 pages, 2 forms, per thousand copies . . . . .	5.00		64 pages, 4 forms, per thousand copies . . . . .	6.00
48 pages, 3 forms, per thousand copies . . . . .	5.25		64 pages, 5 forms, per thousand copies . . . . .	6.25
48 pages, 4 forms, per thousand copies . . . . .	5.50		64 pages, 6 forms, per thousand copies . . . . .	6.50
48 pages, 5 forms, per thousand copies . . . . .	5.75		64 pages, 7 forms, per thousand copies . . . . .	6.75
48 pages, 6 forms, per thousand copies . . . . .	6.00		64 pages, 8 forms, per thousand copies . . . . .	7.00
56 pages, 3 forms, per thousand copies . . . . .	5.50		72 pages, 9 forms, per thousand copies . . . . .	7.50

Without cover, deduct \$1.50. Every added 8-page form, 50c.; every added 16-page form, 75c. In orders less than 1000 use the proportionate value, adding one-tenth. On quarto forms add 10 per cent.

For cloth backs, add \$3.00 and for quarto, \$5.00 per 1000 copies. For holes punched in for strings, \$1.50 per 1000.

USEFUL INFORMATION FOR PRINTERS

**BINDING YEARLY PUBLICATIONS.**

The prices herewith are *net figures* for single books, or two of a kind. For three or more volumes of same finish, 5 per cent. reduction may be made. For ten or more volumes of same finish, a 10 per cent. reduction can be made.

STYLE OF BINDING.	5 x 8	8 x 9	8 x 11	11 x 18	
	UNDER 800 PP.	SIX MONTHS.	SIX MONTHS.	SIX MONTHS.	ONE YEAR.
	NOVELS, LIBRARY BOOKS.	SUCH AS CENTURY, HARPER'S	SUCH AS LESLIE'S MONTHLY	SUCH AS HARPER'S WEEKLY, YOUTH'S COMPANION	
Full cloth, stiff board sides . . . . .	\$0.65	\$0.75	\$1.00	\$1.25	\$1.50
Half sheep or roan, sprinkled edges, cloth or paper sides . . . . .	.75	.90	1.25	2.00	2.50
Full sheep or roan, sprinkled edges . . . . .	.85	1.00	1.50	2.00	2.50
Half sprinkled sheep, library style, cloth sides, sprinkled edges . . . . .	.90	1.15	1.65	2.25	2.75
Full sprinkled sheep, sprinkled edges . . . . .	.95	1.25	1.75	2.50	3.00
Full sprinkled sheep, marbled edges . . . . .	1.05	1.35	1.90	2.75	3.25
Half imitation morocco, cloth or paper sides, sprinkled or marbled edges . . . . .	1.10	1.25	1.75	3.00	3.50
Half genuine morocco, marbled edges . . . . .	1.25	1.50	2.25	3.50	4.00
Gilt edge extra on any book . . . . .	.50	.75	1.00	1.25	1.50

**RE-BINDING FOR PUBLIC LIBRARIES, SCHOOLS, ETC.**

STYLE OF BINDING.	24MO.	18MO.	12MO.	8VO.	4TO.
Half black leather (roan), cloth sides, no leather corners, gilt lettering on back, cloth joint . . . . .	\$0.40	\$0.40	\$0.50	\$0.60	\$1.25
Half sheep leather, cloth sides, no corners, ink lettering on back, cloth joint . . . . .	.30	.30	.40	.50	1.10

**BINDING SHEET MUSIC.**

Half morocco, cloth or paper sides . . . . .	PER VOL.	. \$2.25
Half library roan, cloth or paper sides . . . . .		1.75
Full morocco, flexible . . . . .		3.00
Full roan or buffing, flexible . . . . .		2.00
Full cloth, flexible or stiff . . . . .		1.50

**BINDING NEWSPAPER-FILES.**

One-half canvas-back and paper board sides . . . . .	PER VOL.	. \$1.50
One-half roan, paper sides . . . . .		2.00













