

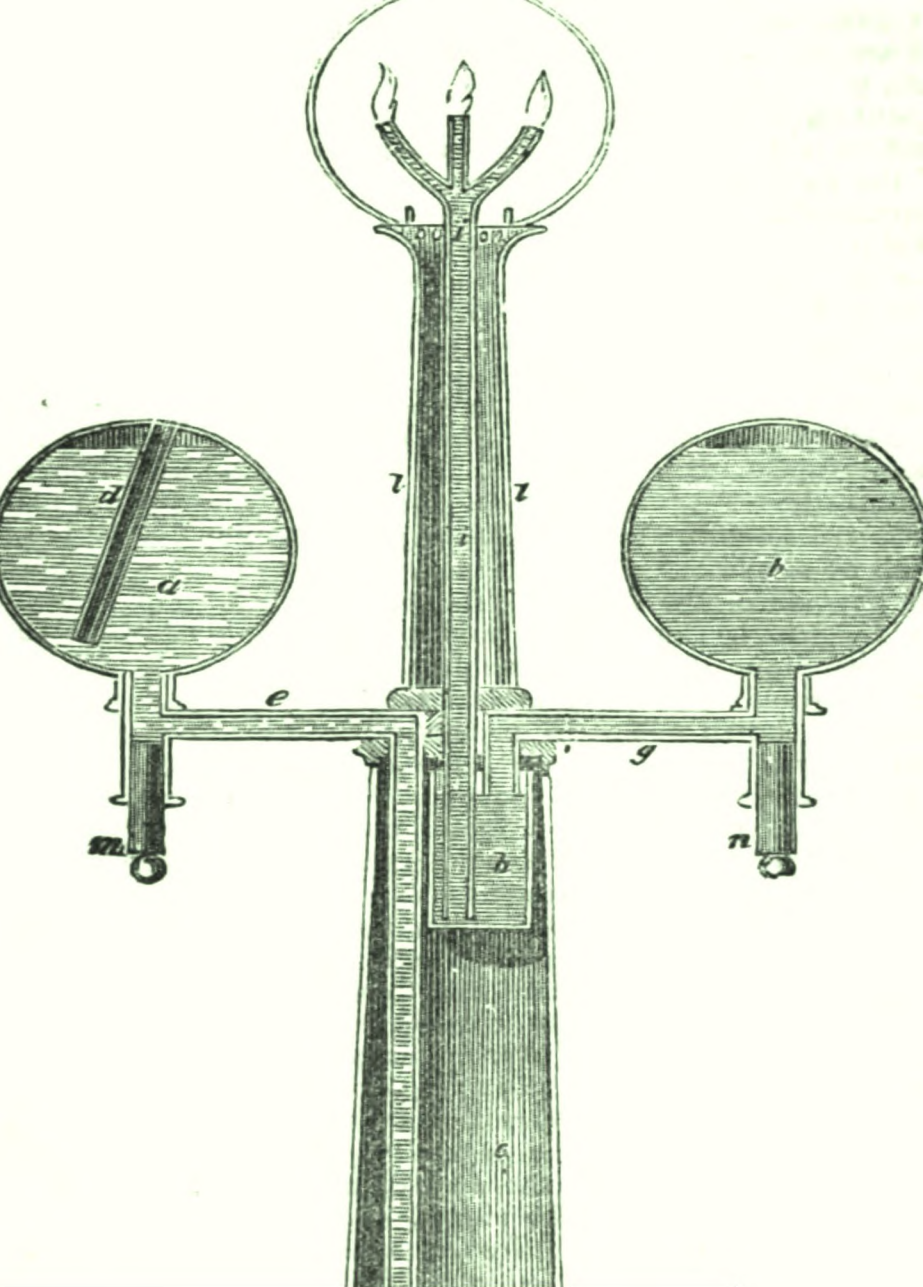
---

This is a reproduction of a library book that was digitized by Google as part of an ongoing effort to preserve the information in books and make it universally accessible.

Google™ books

<http://books.google.com>





*The engineer's and mechanic's encyclopædia*

Luke Hebert





3













THE  
ENGINEER'S AND MECHANIC'S  
**ENCYCLOPÆDIA,**  
COMPREHENDING  
PRACTICAL ILLUSTRATIONS  
OF  
**THE MACHINERY**  
AND  
PROCESSES EMPLOYED IN EVERY DESCRIPTION OF MANUFACTURE  
OF THE  
**BRITISH EMPIRE.**

---

**With nearly Two Thousand Engravings.**

---

BY LUKE HEBERT,

CIVIL ENGINEER,

EDITOR OF THE HISTORY AND PROGRESS OF THE STEAM ENGINE, REGISTER OF ARTS, AND  
JOURNAL OF PATENT INVENTIONS, ETC.

IN TWO VOLUMES.

VOL. II.

---

“How much useful knowledge is lost by the scattered forms in which it is ushered to the world! How many solitary students spend half their lives in making discoveries which had been perfected a century before their time, for want of a condensed exhibition of what is known!”—BUFFON

---

LONDON :  
THOMAS KELLY, 17, PATERNOSTER ROW.

MDCCLXVI.

THE NEW YORK  
PUBLIC LIBRARY  
ASTOR, LENOX  
TILDEN FOUNDATIONS

THE

ENGINEER'S AND MECHANIC'S

ENCYCLOPÆDIA.

---

**ISINGLASS.** A solid glutinous substance, almost wholly gelatine, prepared chiefly from a fish of the sturgeon kind, caught in rivers of Russia and Hungary. The belluga yields the greatest quantity, as being the largest and most plentiful fish in the rivers of Russia; but the sounds, or air bladders of all fresh-water fish, yield, more or less, fine isinglass, particularly the smaller sorts, found in prodigious quantities in the Caspian Sea, and several hundred miles beyond Astracan, in the Wolga, Yaik, Don, and even as far as Siberia. The following is the usual mode of preparing isinglass:—The sounds, or other parts of which it is to be made, are taken from the fish while sweet and fresh, slit open, washed from their slimy sordes, divested of every thin membrane which envelopes the sound, and then exposed, to stiffen a little in the air. In this state they are formed into rolls, about the thickness of a finger, and in length according to the intended size of the staple: a thin membrane is generally selected for the centre of the roll, round which the rest are folded alternately, and about half an inch of each extremity of the roll is turned inwards. The due dimensions being thus obtained, the two ends of what is called short staple are pinned together with a small wooden peg; the middle of the roll is then pressed a little downwards, which gives it the resemblance of a heart-shape; and thus it is laid on boards, or hung up in the air to dry. The sounds which compose the long staple are longer than the former; but the operator lengthens this sort at pleasure, by interfolding the ends of one or more pieces of the sound with each other. The extremities are fastened with a peg like the former, but the middle part of the roll is bent more considerably downwards; and in order to preserve the shape of the three obtuse angles thus formed, a piece of round stick, about a quarter of an inch in diameter, is fastened in each angle with small wooden pegs, in the same manner as the ends. In this state it is permitted to dry long enough to retain its form, when the pegs and sticks are taken out, and the drying completed; lastly, the pieces of isinglass are collocated in rows, by running packthread through the pegholes, for convenience of package and exportation. The common kinds of isinglass, called the “book” and “ordinary staple,” are composed of the membranes, which will not admit of a similar formation with the preceding; the pieces, therefore, after their sides are folded inwardly, are bent in the centre in such manner that the opposite sides resemble the cover of a book, from whence its name: a peg being run across the middle, fastens the sides together, and thus it is dried like the former. This sort is interleaved, and the pegs run across the ends, the better to prevent its unfolding. Ichthyocolla, or isinglass, is one of the purest and finest of the animal gins, of no particular smell or taste. Beaten into threads, it dissolves

pretty readily in boiling water or milk, and forms a gelatinous substance, which yields a mild nutriment, and proves useful, medicinally, in some disorders.

**IVORY.** The tusk of the male elephant. It is an intermediate substance between bone and horn—hard, solid, white, and capable of taking a good polish. The finest, whitest, and most compact ivory comes from Ceylon, which, it is observed, keeps its colour better, and therefore bears a higher value than the ivory of Guinea. The article is chiefly consumed for the handles of knives, for ornamental utensils, instruments, cases, boxes, balls, combs, dice, slabs for miniature paintings, and an infinity of toys. The coal of ivory is also used in the arts under the denomination of ivory black. The tooth of the sea-horse is also called ivory, but from its extreme hardness it is rarely worked but for making artificial teeth, for which purpose it is admirably adapted, on account of the extremely hard steel-like white enamel which covers it. The shavings of ivory procured from the ivory turners, for domestic use, are boiled in water, in the same manner as hartshorn shavings, and form a jelly inferior to none. Any piece of ivory, scraped into shavings, will answer equally well to sending to the turners, which is not always practicable. In the manufacturing of various articles of ivory and bone, a difficulty is experienced on account of their brittleness; they are therefore softened by submitting them to the action of aquafortis for twelve hours, and subsequently, it is said, to the "juice of berries," to preserve the colour. They are thus rendered so soft and pliant, as to take an impression from a dye. They are hardened again by immersing them in strong vinegar for four or five hours. When ivory is discoloured, it may be whitened or bleached by steeping it in a strong solution of alum. The ivory should then be covered with cloth, to prevent it from drying too quickly, which renders it liable to split.

Ivory is stained of various colours in the following manner: *Red.*—Take a quarter of a pound of the cuttings of scarlet cloth, half a pound of soft soap; let the soap be well rubbed into the cloth; then put them into an earthen vessel, and pour upon them two quarts of water; afterwards, boil them for a considerable time, which will extract all the colouring matter. The cloth may then be taken from the vessel, and the coloured liquor pressed out. The ivory to be stained is now to be dipped in aquafortis, then in cold water, and from thence into the dye, whilst it is warm, which will stain it of a beautiful red. *Yellow.*—Boil the ivory in a solution of one pound of alum in two quarts of water, then immerse them for half an hour in a liquid prepared by boiling half a pound of turmeric in a gallon of water, until it be reduced to three quarts, and afterwards plunge the coloured substance into alum water. *Green.*—The dye bath for this colour is best made of a solution of verdigris in aqua fortis; the process, in other respects, may be the same as that described for yellow. *Blue.*—Dip the ivory that has been made green into a hot and strong solution of pearl ashes, which will turn it to a fine blue. *Purple.*—Dissolve one ounce of sal-amoniac in four ounces of aqua regia, to form the dye: prepare the ivory, as in the yellow, by boiling it in a solution of alum. Ivory may be *silvered* by immersing a slip of ivory in a weak solution of nitrate of silver, and letting it remain till the solution has given to it a deep yellow colour; then take it out, and immerse it in a glass vessel of clear water, and thus expose it, in water, to the rays of the sun: in about three hours the ivory acquires a black colour, but the black surface, on being rubbed, soon becomes changed to a brilliant silver.

**IVORY PAPER.** The properties which render ivory so desirable a subject for the miniature painter and other artists, are the evenness and fineness of its grain, its allowing all water colours laid on its surface to be washed out with a soft wet brush, and the facility with which the artist may scrape off the colour from any particular part by means of the point of a knife or other convenient instrument, and thus heighten and add brilliancy to the lights in his painting more expeditiously and efficaciously than can be done in any other way. The objections to ivory are—its high price, the impossibility of obtaining plates exceeding very moderate dimensions, and the coarseness of grain in the larger of these; its liability, when thin, to warp by changes of weather, and its

property of turning yellow by long exposure to the light, owing to the oil which it contains. Traces made on the surface of this paper by a hard black lead pencil are much easier effaced by Indian rubber than from common drawing paper, which circumstance, together with the extremely fine lines which its hard and even surface is capable of receiving, peculiarly adapts it for the reception of the most delicate kind of pencil drawings and outlines. The colours laid upon it have a greater brilliancy than when laid upon ivory, owing to the superior whiteness of the ground. Colours on ivory are apt to be injured by the transudation of the animal oil, a defect which the ivory paper is free from. The following is the process given by Mr. Ainslie (of Stratton ground, Westminster,) to the Society of Arts, for which he was voted the sum of thirty guineas. "Take a quarter of a pound of clean parchment cuttings, and put them into a two-quart pan, with nearly as much water as it will hold; boil the mixture gently for four or five hours, adding water from time to time, to supply the place of that driven off by evaporation; then carefully strain the liquor from the dregs through a cloth, and when cold it will form a strong jelly, which may be called size No. 1. Return the dregs of the preceding process into the pan, fill it with water, and again boil it as before, for four or five hours; then strain off the liquor, and call it size No. 2. Take three sheets of drawing paper, (outsides will answer the purpose perfectly well, and being much cheaper are therefore to be preferred,) wet them on both sides with a soft sponge dipped in water, and paste them together with the size No. 2. While they are still wet, lay them on a table, and place them on a smooth slab of writing slate, of a size somewhat smaller than the paper; turn up the edges of the paper, and paste them on the back of the slate, and then allow them to dry gradually; wet, as before, three more sheets of the same kind of paper, and paste them on the others, one at a time; cut off with a knife what projects beyond the edges of the slate, and when the whole has become perfectly dry, wrap a small piece of slate in coarse sand paper, and with this rubber make the surface of the paper quite even and smooth; then paste on an inside sheet, which must be quite free from spots or dirt of any kind, cut off the projecting edges as before, and when dry, rub it with fine glass paper, which will produce a perfectly smooth surface. Now take half a pint of the size No. 1, melt it with a gentle heat, and then stir into it three table spoonful of fine plaster of Paris; when the mixture is completed, pour it out on the paper, and with a soft wet sponge distribute it as evenly as possible over the surface; then allow the surface to dry slowly, and rub it again with fine glass paper. Lastly, take a few spoonful of the size No. 1, and mix it with three-fourths its quantity of water; unite the two by a gentle heat, and when the mass has cooled, so as to be in a semi-gelatinous state, pour about one-third of it on the surface of the paper, and spread it evenly with the sponge; when this has dried, pour on another portion, and afterwards the remainder; when the whole has again become dry, rub it over lightly with fine glass-paper, and the process is completed; it may accordingly be cut away from the slab of slate, and is ready for use." The quantity of ingredients above mentioned is sufficient for a piece of paper  $17\frac{1}{2}$  by  $15\frac{1}{2}$  inches. Plaster of Paris gives a perfectly white surface; oxide of zinc, mixed with plaster of Paris, in the proportion of four parts of the former to three of the latter, gives a tint very near resembling ivory; precipitated carbonate of barytes gives a tint intermediate between the two.

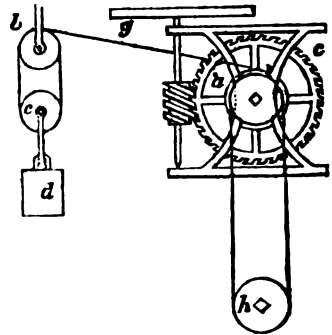
## J.

**JACK**, in Mechanics, a portable machine for raising great weights through a small space. It consists of a rack and pinion inclosed within a strong wooden case, and the power is applied by means of a winch or handle fixed upon the axis of the pinion; the upper end of the rack is formed into two horns, to take

the better hold of the article to be elevated; and from the lower end, two prongs project laterally through a longitudinal groove in the case, which are used upon occasions when there is not room to introduce the jack beneath the load. To prevent the labourers being overpowered, there is a ratchet-wheel and pall on the axis of the pinion.

**JACK (KITCHEN).** A machine in which the descent of a weight is made to turn a spit. The ordinary construction is represented in the annexed sketch,

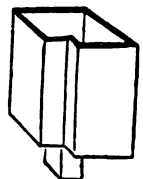
which may be briefly described as follows:—*a* is a barrel, round which is coiled a line of considerable length; the other end of this line is reeved through two threefold or fourfold pulleys, *a b* and *c*, generally placed against the outside of the house, and at a considerable height, so as to allow the greater range for the weight *d* attached to the lower block *c* to act in. Upon the spindle of the barrel is fixed a pulley *e*, and a similar one is also fitted to the spit *g*, and round these two pulleys passes an endless chain. The weight *d* being sufficient to overcome the friction of the machine, descends slowly, and uncoils the line by turning the barrel round, which causes the spit likewise to revolve. To render the motion equal, and to prevent the jerks which would arise in the case of the meat being unequally spitted, so as to act with more force on one side of the spit than on the other, a wheel of about forty teeth is placed on the axis of the barrel, and works into a double threaded screw, placed upon the spindle of the horizontal fly, which thus performs a revolution for every two teeth of the wheel, or twenty revolutions for one of the barrel *a*, and by this great velocity prevents any alteration in the motion of the barrel. When the weight has descended through its range, it is wound up by a handle which can be fixed on a square end of the barrel spindle. The Chinese crane would, perhaps, be found a superior arrangement to the treble or fourfold blocks, as the friction is considerably less.



**JACK (SMOKE).** Another contrivance for the same purpose as the former, but acting not by a weight, but by means of the smoke or rarefied air passing up the chimney, which striking against a set of oblique vanes, fixed to a vertical spindle, causes it to revolve with great rapidity. Upon the spindle is fixed a small bevelled wheel working into another small wheel placed upon a horizontal axis, which has a screw cut upon the other end of it; this screw works into a wheel on the axis of the pulley that drives the spit: the latter is thus carried slowly round. The vanes should be placed in the narrow part of the chimney, where the motion of the smoke is swiftest, and should occupy nearly the whole space, so as to intercept the greatest part of the current.

**JACK IN THE BOX.** A large wooden solid screw, turning in a hollow one which forms the upper part of a strong wooden box, shaped like the frustrum of a pyramid: it is used by means of levers, passing through holes in it, as a press in packing, and for other purposes.

**JAMB-POSTS.** The side posts of doors. Mr. T. N. Parker having noticed how rapidly the lower ends of door-posts decayed where they are exposed to wet, contrived a cast-iron socket for them, which is much used in Shropshire, and might be generally introduced with advantage. The sketch in the subjoined cut represents one of them beautifully cast by the Colebrook-Dale Company; the weight of them is only 7lbs. the pair, and they are retailed in Oswestry at 2½d. the pound. When the increased durability and strength conferred by these metal sockets, to an important part of a building, is considered, their trifling cost will not, we think, form an impediment to their employment.



**JAPANING.** The art of painting and varnishing, after the manner originally practised by the natives of Japan, in the East Indies. It is employed for the purpose of preserving and beautifying various articles, usually of wood and metal, as well as of paper, leather, and cloth, when they are properly prepared for the purpose. Those articles we most commonly find japanned, are pieces of household furniture, cabinet work, boxes of all kinds, trays, screens, &c. and, very generally, those articles made of any of the above-mentioned or similar materials, which it may be desired to preserve from moisture; and this it is admirably adapted to effect, from its drying very hard, and being impervious to water at all moderate temperatures, even to boiling in some cases; but it may be employed on any dry substance that is sufficiently inflexible to prevent the japan coating from being cracked or forced off. The true japan, or that said to be used by the natives of Japan and China, is a sort of varnish or lacker peculiar to itself. It is sometimes brought over to this country; but on account of the injury arising from its poisonous qualities, to those persons employed in working with it, is now seldom used. It is the juice of a peculiar tree growing in those parts, and is collected by making an incision into the lower part of the trunk of the tree, and placing vessels underneath to receive it. This juice has the appearance of cream when it first runs from the tree, but on exposure to the air it becomes black. It is prepared for use by submitting it to the action of the open air in shallow vessels, and is kept constantly stirred for many hours, so that by having all parts equally exposed, it may become of a uniform deep black. A portion of well-charred wood reduced to a fine powder is added, and it is then fit for use. The Japanese first spread it thinly and evenly over the body intended to be japanned, and then dry it in the sun. If necessary, another coat is laid on, and dried as before. It very soon becomes harder than most of the substances on which it is laid. As soon as it is sufficiently hard, it is polished with a smooth stone and water, until it becomes as smooth and even as a plate of glass, and then wiping it dry, it is ready to be varnished, except when figures or other ornaments are to be drawn on it in gold or silver: in that case, the form of the figures or other ornaments is to be traced on the work with a pencil, in the varnish noticed below. When this varnish is almost dry, the gold or silver leaf is to be laid on; the whole is then ready to receive the varnish, or finishing coat, which must be spread on thin, and as evenly as possible. This varnish is a particular sort of oil procured in Japan, boiled and mixed with turpentine. When any other colour than black is desired, the proper colour must be mixed with the varnish, and the whole spread on, particular care being taken that it be laid on evenly. The above is the method of japanning said to be practised by the natives of Japan. Our method differs from it considerably; it is less durable, but its practice is not so injurious to the health. We in some cases employ a priming or under coat for the purpose of filling up any inequalities, and making smooth the surface to be japanned; but at other times the priming is altogether omitted, the coloured varnish or proper japan ground being applied immediately to the substance to be japanned. The former is the method that was usually practised, and still is, in those cases when the surface is very uneven and rough; but when the surface is smooth, as in the case of metals, smooth grained wood, &c. it is now always rejected. The advantage of using the priming or undercoat is, that it makes a saving in the quantity of varnish used, because the matter of which the priming is composed fills up the inequalities in the surface of the body to be varnished, and makes it easy, by means of rubbing and water polishing, to procure an even surface for the varnish. This was, therefore, such a convenience in the case of rough and uneven surfaces, that it became an established method, and is still retained in many instances. There is, however, this inconvenience always attending the use of priming or undercoat of size and whitening, that the japan coats of varnish and colour will be constantly liable to be cracked and peeled off by any violence, and will not endure near so long as the bodies japanned in the same manner, but without the priming. This may be easily observed by comparing those articles that have been some time in wear, especially snuff-boxes, in the



japanning of which the priming has been used, with those in which it has been omitted; the latter never peel or crack, or suffer damage, unless by great violence, and such a continual rubbing as wastes away the substance of the varnish, while the japan coats of the former crack and fly off in flakes, whenever any knock or fall, especially at the edges, exposes them to injury. The Birmingham manufacturers who originally practised the japanning only on metals, to which the reason before stated for the use of priming did not apply, and who took up this art of themselves, as a new thing, of course omitted at first the use of any such undercoat, and not finding it more necessary in the instance of *papier machè* and some other things, than on metals, continue still to reject it; on which account the boxes and other articles of their manufacture are, with regard to the wear, much better than those on which the priming is still used.

Having thus noticed the method originally practised, and the chief variation in the method now employed, we shall pass on to the manner of proceeding with the work to be japanned; the first in order will be the—

*Priming.*—The priming is a composition of strong size and whiting. The size should be of a consistency between the common double size and glue, and mixed with as much whiting as will give it a good body, so as to hide the surface of whatever it is laid upon. But when the work is of a more particular kind, it is better to employ the glover's or the parchment size, instead of the common, and if about a fourth of isinglass be added it will be still better, and if not laid on too thick, will be much less liable to peel or crack. The work should be prepared for this priming by being well cleaned, and brushed over with hot size, diluted with two-thirds of water, provided it be of common strength; the priming should then be laid on with a brush as evenly as possible, and left to dry. If the surface be tolerably even on which the priming is used, two coats of it laid on in this manner will be sufficient; but if on trial with a wet rag or sponge it will not receive a proper water polish on account of any inequalities not sufficiently filled up, one or more coats must be given it. Previous to the last coat being laid on, the work should be smoothed by rubbing it with the Dutch rushes, or fine glass paper. When the last coat is dry, the water polish should be given, by passing over every part of it with a fine rag or sponge moistened, till the whole appear perfectly plain and even; the priming will then be completed, and the work ready to receive the japan ground, or coloured varnish. But when wood or leather is to be japanned, the latter being first securely stretched on a frame or board, and no priming is used, the best preparation is to lay on two or three coats of coarse varnish, prepared in the following manner: "Take of rectified spirits of wine one pint, and of coarse seed-lac and resin, each two ounces. Dissolve the seed-lac and resin in the spirit, and then strain off the varnish." This varnish, like all others formed of spirits of wine, must be laid on in a warm place, and all dampness should be avoided; for either cold or moisture chills it, and thus prevents its taking proper hold of the substance on which it is laid. When the work is so prepared, or by the priming with the composition of size and whiting before described, the proper japan ground must be laid on.

*Japan Grounds.*—The proper japan grounds are either such as are formed by the varnish and colour, where the whole is to remain of one simple colour, or by the varnish with or without colour, on which some painting or other decoration is afterwards to be laid. This ground is best formed of shell-lac varnish, and the colour desired; except in the case of white, which requires a peculiar treatment, as we shall presently explain, or when great brightness is required, in which case also other means must be pursued. The following is the composition and manner of preparing the shell-lac varnish:—"Take of the best shell-lac, five ounces; break it into a very coarse powder, and put it into a bottle that will hold about three pints or two quarts; add to it one quart of rectified spirits of wine, and place the bottle in a gentle heat, where it must continue two or three days, but should be frequently well shaken. The gum will then be dissolved, and the solution should be filtered through a flannel bag; and when what will pass through freely is come off, it should be put into

a proper sized bottle, and kept carefully stopped up for use. The bag may also then be pressed with the hand till the remainder of the fluid be forced out; which, if it be tolerably clear, may be employed for coarser purposes, or kept to be added to the next quantity that shall be made." Any pigments whatever may be used with the shell-lac varnish, which will give the tint of the ground desired, and they may be mixed together to form any compound colours; but, with respect to such as require peculiar methods for producing them of the first degree of brightness, we shall particularize them below. They should all be ground very smooth in spirits of turpentine, and then mixed with the varnish. It should be spread over the work very carefully and even with a camel-hair brush. As metals never require the priming of size and whitening, the japan ground may be applied immediately to them, without any other preparation than cleaning, except in the instances referred to below.

*White Japan Grounds.*—The forming a ground perfectly white, and of the first degree of hardness, has not yet been attained in the art of japanning, as there are no substances which can be dissolved, so as to form a very hard varnish, but what have too much colour not to deprave the whiteness. The nearest approach, however, to a perfect white varnish already known, is made by the following composition:—"Take flake white, or white-lead, washed and ground up with the sixth of its weight of starch, and then dried; temper it properly for spreading with the mastic varnish prepared in the following manner:—take five ounces of mastic in powder, and put it into a proper bottle, with a pound of spirit of turpentine; let them boil in a gentle heat till the mastic be dissolved, and if there appear to be any foulness, strain off the solution through flannel." Lay these on the body to be japanned, prepared either with or without the priming, in the manner as above directed, and then varnish over it with five or six coats of the following varnish:—"Provide any quantity of the best seed-lac, and pick out of it all the clearest and whitest grains; take of this seed-lac two ounces, and of gum animi three ounces, and dissolve them, being previously reduced to a coarse powder, in about a quart of spirit of wine, and strain off the clear varnish." The seed-lac will give a slight tinge to this composition; but it cannot be omitted where the varnish is wanted to be hard, though where a softer will answer the end, the proportion may be diminished, and a little crude turpentine added to the gum animi, to take off the brittleness. A very good varnish entirely free from brittleness may be formed by dissolving gum animi in old nut or poppy oil, which must be made to boil gently when the gum is put into it. The ground of white may be laid on in this varnish, and then a coat or two of it may be put over the ground, but it must be well diluted with oil of turpentine before it is used. This, however, is a long time in drying, and is more liable to injury than the other, from its tenderness.

*Blue Japan Grounds* may be formed of bright Prussian blue, or verditer glazed over with Prussian blue, or of smalt. The colour may be mixed with the shell-lac varnish, as before directed, but as the shell-lac will somewhat injure the colour by giving it a yellow tinge, where a bright blue is required, the method before directed in the case of white grounds must be pursued.

*For a Scarlet Japan Ground*, vermilion may be used; but its effect is much improved by glazing it over with carmine or fine lake. If, however, the highest degree of brightness be required, the white varnish must be used.

*For Bright Yellow Grounds*, king's yellow may be used, and the effect will be heightened by dissolving powdered turmeric root in the spirit of wine, of which the upper or polishing coat is made, which spirit of wine must be strained from off the dregs before the seed-lac be added to it to form the varnish. The seed-lac varnish is not equally injurious here, as in the case of some other colours, because, being tinged with a reddish yellow, it is little more than an addition to the force of the colours.

*Green Grounds* may be produced by mixing the Prussian blue, or distilled verdigris, with king's yellow, and the effect will be rendered extremely brilliant, by laying them on a ground of leaf-gold. They may any of them be used successfully with good seed-lac varnish, for the reasons before given.

*Orange Coloured Grounds* may be formed by mixing vermilion, or red lead, with king's yellow or orange lake; or red orpiment will make a brighter orange ground than can be produced by any mixture.

*Purple Grounds* may be produced by the mixture of lake or vermilion with Prussian blue. They may be treated as the rest with respect to the varnish.

*Black Grounds* may be formed by either ivory-black or lamp-black; but the former is preferable. These may be always laid on with the shell-lac varnish, and have their upper or polishing coats of common seed-lac varnish.

*Common Black Japan Grounds on Metal*, by means of heat, are thus performed: The piece of work to be japanned must be painted over with drying oil, and when it is moderately dry, must be put into a stove of such heat as will change the oil black without burning it. The stove should not be too hot when the work is put into it, nor the heat increased too fast, either of which errors would make it blister; but the slower the heat is augmented, and the longer it is continued, provided it be restrained within a due degree, the harder will be the coat of japan. This kind of japan requires no polish, having received, when properly managed, a sufficient one from the heat.

*The Tortoise-shell Ground*, produced by heat, is not less valuable for its great hardness, and bearing to be made hotter than boiling water without damage, than for its beautiful appearance. It is to be made by means of a varnish prepared in the following manner:—Take one gallon of good linseed oil, and half a pound of amber; boil them together till the oil becomes very brown and thick; strain it then through a coarse cloth, and set it again to boil, in which state it must be continued till it acquire a consistence resembling that of pitch; it will then be fit for use. Having thus prepared the varnish, clean well the substance which is to be japanned; then lay vermilion, tempered with shell-lac varnish, or with drying oil very thinly diluted with oil of turpentine, on the places intended to imitate the more transparent parts of the tortoise-shell. When the vermilion is dry, brush the whole over with black varnish, tempered to a due consistence with the oil of turpentine. When set and firm, put the work into a stove where it may undergo a very strong heat, which must be continued a considerable time: if even three weeks or a month it will be better. This ground may be decorated with painting and gilding in the same manner as any other varnished surface, which had best be done after the ground has been hardened; but it is well to give a second annealing with a more gentle heat after it is finished. A very good black japan may be made by mixing a little japan gold size with ivory or lamp-black; this will bear a good gloss without requiring to be varnished afterwards.

*Of Painting Japan Work.* Japan work should be painted with colours in varnish; and in that case, all pigments or solid colours whatever may be used, and the peculiar disadvantages which attend several kinds, with respect to oil or water, cease with regard to this sort of vehicle, for they are secured by it, when properly managed, from the least hazard of changing or flying. The preparation of colours for this use consists, therefore, in bringing them to a due state of fineness, by grinding on a stone in oil of turpentine. The best varnish for binding and preserving the colours, is shell-lac; this, when judiciously managed, gives such a firmness and hardness to the work, that, if it be afterwards further secured with a moderately thick coat of seed-lac varnish, it will be almost as hard and durable as glass. The method of painting in varnish is, however, more tedious than in oil or water. It is therefore now very usual in the japan work, for the sake of dispatch, and in some cases for the freer use of the pencil, to lay the colours on with oil well diluted with spirits of turpentine. This oil or japan gold size, as it is called, may be made in the following manner:—Take one pound of linseed oil, and four ounces of gum animi; set the oil to boil in a proper vessel, and then add the gum animi gradually in powder, stirring it well, until the whole be commixed with the oil. Let the mixture continue to boil till it appears of a thick consistence, and then strain the whole through a coarse cloth, and keep it for use. The colours are also sometimes laid on in gum water, but the work done in this manner is not near so durable as that done in varnish or oil. However, those who practise

japanning for their amusement only, and consequently may not find it worth their while to encumber themselves with the preparations necessary for the other methods, may paint with water colours. If the colours are tempered with strong isinglass size and honey, instead of gum water, the work will not be much inferior to that done by the other method. Water colours are sometimes laid on grounds of gold, in the manner of other paintings, and look best without any varnish over them; and they are sometimes so managed as to have the effect of embossed work. The colours in this way of painting are prepared by means of isinglass size corrected with honey or sugar candy. The body with which the embossed work is raised, is best formed of strong gum water, thickened to a proper consistence with bole armenian and whiting in equal parts; which, being laid on in the proper figures, and repaired when dry, may be then painted with the intended colours tempered in the isinglass size, or in the general manner with shell-lac varnish.

*Of Varnishing Japan Work.*—The last and finishing process in japanning consists in the laying on and polishing the outer coats of varnish, which are equally necessary whether the plain japan ground be painted on or not. This is generally best done with common seed-lac varnish, except on those occasions where other methods have been shown to be more expedient; and the same reasons which decide as to the propriety of using the different varnishes as regards the colours of the ground, hold equally with those of the painting; for where brightness is a material point, and a tinge of yellow would injure it, seed-lac must give way to the whiter resins; but where hardness and tenacity are essential, it must be adhered to; and where both are necessary, a mixed varnish must be adopted. This mixed varnish should be made of the picked seed-lac, as directed in the case of the white japan grounds. The common seed-lac varnish may be made thus:—Take three ounces of seed-lac, and wash it well in several waters; then dry it and powder it coarsely, put it, with a pint of rectified spirit of wine, into a bottle, so that it be not more than two-thirds full; shake the mixture well together, and place the bottle in a gentle heat till the seed appear to be dissolved, the shaking being in the meantime repeated as often as may be convenient; and then pour off all the clear, and strain the remainder through a coarse cloth. The varnish thus prepared must be kept for use in a bottle well stopped. The whiter seed-lac varnishes are used in the same manner as the common, except with regard to the substance used in polishing; which, where a pure white, or great clearness of other colours is in question, should be itself white; while the browner sorts of polishing dust, as being cheaper, and doing their business with greater dispatch, may be used in other cases. The pieces of work to be varnished should be placed near the fire, or in a warm room, and made perfectly dry, and then the varnish may be laid on with a flat camel-hair brush made for the purpose: this must be done very rapidly, but with great care; the same place should not be passed twice over, in laying on one coat, if it can possibly be avoided: the best way of proceeding is to begin in the middle, and pass the brush to one end, then, with another stroke from the middle, pass it to the other end, taking care that, before each stroke, the brush be well supplied with varnish. When one coat is dry another must be laid over it in like manner, and this must be continued at least five or six times. If, on trial, there be not a sufficient thickness of varnish to bear the polish, without laying bare the painting or ground colour underneath, more must be laid on. When a sufficient number of coats is thus laid on, the work is fit to be polished; which must be done, in common cases, by rubbing it with a piece of cloth, or felt, dipped in tripoli, or pumicestone finely powdered. But towards the end of the rubbing a little oil of any kind should be used with the powder; and when the work appears sufficiently bright and glossy, it should be well rubbed with the oil alone, to clean it from the powder, and give it a still greater lustre. In the case of white grounds, instead of the tripoli, fine putty or whiting should be used, but they should be washed over to prevent the danger of damaging the work from any sand, or other gritty matter, that may happen to be mixed with them. It greatly improves all kinds of japan work to harden the varnish by means of heat, which, in every degree

that it can be applied, short of what would burn or calcine the matter, tends to give it a more firm and strong texture. Where metals form the body, therefore, a very hot stove may be used, and the work may be continued in it a considerable time, especially if the heat be gradually increased; but where wood, or *papier maché* is in question, heat must be sparingly used.

**JIB.** The projecting frame of a crane, to which the weight or goods are suspended; the term is a corruption of *gibbet*, evidenced by the similarity of structure. Jib is also the name of the foremost sail of a ship.

**JIB-BOOM** is a continuation of the bowsprit forward, being run out from its extremity in a similar manner to a top-mast on a lower mast. There is also the *flying jib-boom*, which is a boom extending beyond the preceding, by passing through two boom-irons fixed to the same.

**JIGGER.** A machine consisting of a piece of rope about five feet long, with a block at one end, and a sheave at the other, used to hold on the cable when it is heaved into the ship by the revolution of the windlass. This is done by passing the tail round the cable near the windlass, and the hind part of the rope, coming over the sheave, is stretched aft by means of another rope passing round the jigger block.

**JUNK.** Remnants or pieces of old cable, which are usually cut into small pieces for making mats, gaskets, &c.

**JURY-MAST.** A temporary mast erected in a ship in the place of the proper one.

## K.

**KALEIDOSCOPE.** An instrument for creating and exhibiting an infinite variety of beautiful forms, pleasing the eye by an ever-varying succession of splendid tints and symmetrical figures, and enabling the observer to render permanent such as may appear appropriate for any branch of the ornamental arts. This instrument, the invention of Dr. Brewster, in its most common form consists of a tin tube, containing two reflecting surfaces, inclined to each other at any angle which is an aliquot part of  $360^\circ$ . The reflecting surfaces may be two plates of glass, plain or quicksilvered, or two metallic surfaces, from which the light suffers total reflection. The plates should vary in length, according to the focal distance of the eye: five, six, seven, eight, nine, and ten inches, will, in general, be most convenient; or they may be made only one, two, three, or four inches long, provided distinct vision is obtained at one end, by placing at the other an eye-glass whose focal length is equal to the length of the reflecting planes. The inclination of the reflector that is in general most pleasing is  $18^\circ$ ,  $20^\circ$ ,  $22\frac{1}{2}^\circ$  or the 20th, 18th, and 16th part of a circle; but the planes may be set at any required angle, either by a metallic, a paper, or cloth joint, or any other simple contrivance. When the two planes are put together, with their straightest and smoothest edge in contact, they will have the form of a book opened at one side. When the instrument is thus constructed, it may be covered up either with paper or leather, or placed in a cylindrical or any other tube, so that the triangular aperture may be left completely open, and also a small aperture at the opposite extremity of the tube. If the eye be placed at the aperture, it will perceive a brilliant circle of light, divided into as many sectors as the number of times that the angle of the reflectors is contained in  $360^\circ$ . If this angle be  $18^\circ$ , the number of sectors will be 20; and whatever be the form of the aperture, the luminous space seen through the instrument will be a figure produced by the arrangement of twenty of these apertures round the joint as a centre, in consequence of the successive reflections between the polished surfaces. Hence it follows that if any object, however ugly or irregular in itself, be placed before the aperture, the part of it that can be seen through the aperture will be seen also in every sector, and every image of the object will coalesce into a form mathematically symmetrical, and highly pleasing to the eye. If the object be put in motion, the combination

of images will likewise be put in motion, and new forms, perfectly different, but equally symmetrical, will successively present themselves, sometimes vanishing in the centre, sometimes emerging from it, and sometimes playing around in double and opposite oscillations. When the object is tinged with different colours, the most beautiful tints are developed in succession, and the whole figure delights the eye by the perfection of its forms, and the brilliancy of its colouring. The eye-glass placed immediately against the end of the mirrors, as well as another glass similarly situated at the other end, is of common transparent glass. The tube is continued a little beyond this second glass, and at its termination is closed by a ground glass, which can be put on and off. In the vacant space thus formed, beads, pieces of coloured glass, and other small bright objects are put. The changes produced in their position by turning the tube give rise to the different figures.

**KAOLIN.** The name given to a kind of earth, which forms one of the ingredients in the manufacture of oriental porcelain. The other ingredient, which is called petuntse, is easily vitrifiable, while kaolin is scarcely so; hence, it is said, the action of the fire upon the mixture causes that semi-vitrification called porcelain. M. Bomare, who analysed some Chinese kaolin, states its composition to be a compound earth, consisting of clay, to which it owes its tenacity; of calcareous earth, whence its mealy appearance; and of crystals of mica and quartz. Similar earths to the kaolin are often found in the neighbourhood of granites.

**KEDGE.** A small anchor used to keep a ship steady and clear from her bower anchor while she rides in a harbour or river. They are generally furnished with an iron stock, which is easily displaced for the convenience of stowing.

**KEEL.** The principal piece of timber in a ship, which is usually first laid on the blocks in building; it supports and unites the whole fabric, since the stem and stern posts which are elevated on its ends, are, in some measure, a continuation of the keel, and serve to connect and enclose the extremities of the sides by transoms, as the keel forms and unites the bottom by timbers.

*False-keel* is a strong thick piece of timber bolted to the bottom of the keel, which is very useful in preserving its lower side; in large ships of war the false keel is composed of two pieces called the upper and lower false keels.

*Keel* is also a name given to a low, flat bottomed vessel, used in the river Tyne to bring the coals down from Newcastle for loading the colliers; hence a collier is said to carry so many keels.

**KEELSON.** A piece of timber forming the interior of the keel, being laid upon the middle of the floor-timbers immediately over the keel, and serving to bind and unite the former to the latter by means of long bolts driven from without, and clinched on the upper side of the keelson.

**KELP.** A very impure carbonate of soda, obtained by the incineration of sea-weed, and chiefly employed in the manufacture of glass. The cultivation of the marine plants for this purpose is now much encouraged, from the increased value it gives to those estates which have an extent of coast adapted to the growth of the peculiar kinds of weed best suited to the manufacture of kelp. There is a very great difference in the product of soda from different plants, some yielding as much as 5 per cent. of the alkali, while others, not even 1 per cent. Those parts of the coast which are exposed to the fury of tempests, or to a heavy rolling surf, prevent the plant from taking root. They thrive best in sheltered bays, where the retreat of the tide leaves uncovered an extensive surface of rocky ground, to which the plants adhere by their roots. The plant commonly called tangle is the only one to be obtained in exposed situations; these adhere with great force to the rocks, and are obtained at the low ebb of spring tides; they are however of a substantial nature, and are considered to repay well for the labour of collecting, which is usually effected by cutting them off with a sickle or reaping hook. The spring is the best time for making kelp. The marine plants, or sea weeds, are collected without distinction of kind, under the general term of wrack, or verack (which are probably corruptions of the French word *vraic*), and are first dried in the air and

sun precisely in the same manner as in the making of hay, being spread and made up into cocks and stacks, so as to keep it as much as possible from the rain; care is likewise taken to prevent its getting muddy; and such as may collect mud in dragging it up the beach, is washed in the waves by means of pitch-forks or rakes. Experience has determined that the kilns for burning vraic should not exceed about 3 feet in width inside, nor more than 2 feet 6 inches high, but they may be of any convenient length; usually they are about 18 feet. In some places holes are dug in the ground to form the kilns, which are lined with stone; but in these all the vraic is rarely completely burned, and the unburned portion yields no alkali. It is now generally deemed preferable to erect the kiln on a firm level piece of ground, of such rough stones as can be easily got together, and without mortar or cement, but the windward side of the kiln is generally covered up with turfs on the outside, and if the wind be violent, on all sides. The process of burning is commenced by igniting some furze or heath in the kiln, on which the vraic is then thrown lightly in small quantities at a time, until the whole body of the kiln is fully ignited. The additions are then continued to be made with care, by only throwing on small quantities at a time, where a red hole appears in the mass; and thus the feeding is continued until the collection of vraic is expended; then as soon as red holes appear, the less ignited portion is stirred into them. The want of due attention to the thorough and uniform burning of the vraic, causes a great deterioration in the value of the product. Towards the close of the burning, three or four men are usually employed in actively raking the ashes with the kelp-irons until the whole contents of the kiln become a semi-fluid mass. Sometimes a portion of the kelp will be found congealed to the sides of the kiln; this is then removed and worked up with the rest, that it may incorporate whilst hot. If after the raking is begun, the materials still continue hard and dry, they are allowed to burn a little longer. Sometimes common salt and saltpetre are added to the ashes to increase the ignition and bring the ashes to the desired semi-fluid consistence; but this measure is seldom found necessary, except when the vraic has been wetted by rain prior to burning. When a new burning is commenced, the remaining unfused ashes from the previous operation are introduced into the kiln by degrees along with the fresh vraic, but not until the fire has become fierce, and the largest and hardest pieces should be put in a row along the centre of the kiln. The kelp, after being made, should be carefully preserved from moisture. In Scotland the kelp makers usually break the lumps into pieces of about 2 cwt. each, which are piled into conical heaps, covered with dry vraic, and over all a layer of turf; this preserves it well until the time of shipment. Kelp is esteemed of good quality when, on breaking a piece, it is hard, solid, and has some reddish and light blue shades running through it. When it has none of its peculiar salt taste, it is unfit for making ley, though it may be of use to glass makers.

KERMES, is an insect found in many parts of Asia and the south of Europe. On account of their figure they were a long time taken for the seeds of the tree on which they feed, whence they were called grains of kermes; they also bore the name of vermilion. It has been much used in dyeing worsted and woollen cloth of a scarlet colour, though the preference is given to the scarlet from cochineal, especially since the discovery of the mode of heightening its tint by the solution of tin.

KERMES-MINERAL is usually prepared by 1 pound of common antimony with 22½ lbs. of the sub-carbonate of potash, and 20 gallons of water in an iron pot, filtering the liquor whilst hot into earthen pans, and letting it cool slowly for 24 hours, the kermes-mineral is deposited in the form of a powder of a deep purple brown colour. The supernatant liquid, which yields an orange coloured sediment, called the golden sulphur of antimony, is much used by the calico printers in the following manner:—They evaporate and crystallize the supernatant liquor; the crystals are then dissolved in fresh water, and with this solution, thickened with starch or gum, they print their cloths; the cloths after being dried, are passed through a weak acid liquor, which separates the golden sulphur and fixes it on the cloth. M. Fabroni states that a much finer

**kermes-mineral** may be obtained by employing tartar in lieu of the alkali in the usual process. Three or four parts of the tartar are to be mixed with one part of powdered sulphuret of antimony, and exposed to a red heat in a crucible, until the entire decomposition of the tartar is indicated by the cessation of fumes; the mass should then be dissolved in warm water, be filtered, and left to cool, when an abundance of very fine deep coloured kermes will be deposited in the bottom of the vessel. This abundance of the kermes is, however, not attended with any diminution of the quantity or brilliancy of the golden sulphuret subsequently obtained by the addition of acid to the mother liquor.

**KETCH.** A vessel equipped with two masts, viz. the main-mast and the mizen-mast, and usually from 100 to 200 tons burthen. A bomb-ketch is a vessel rigged ketch fashion, and equipped for firing mortars.

**KEY.** An instrument for opening locks, &c. This term is applied to a great variety of things which it is needless even to enumerate.

**KEY OR QUAY.** A long wharf by the side of a harbour, river, or canal, furnished with posts and rings, whereby ships and boats may be secured; also with cranes, capstans, and other convenient mechanism for loading and unloading.

**KILDERKIN.** A cask that holds 2 firkins or 18 gallons, or 72 quarts. Two kilderkins are a barrel, three a hogshead, and six a butt.

**KETTLE.** A general name given to variously formed vessels employed in culinary and other operations. Mr. D. Gordon introduced an improvement upon them, which is explained by the subjoined cut. It consists simply in inclosing them in an outer casing which surrounds their sides, but leaves them open at the bottom for the flame of a lamp to act upon it. When heat is applied to vessels so constructed, the plate of air between the cases acquires such a temperature in the upper part as to be capable of melting a rod of glass if passed up the cavity. In kettles of the usual construction, a much greater part of the heated air escapes, without producing any useful effects, than in Mr. Gordon's, which is proved by water being sooner boiled in the latter; an economy of time as well as of fuel is thus obtained. Mr. Gordon had various other culinary vessels constructed on a similar plan.

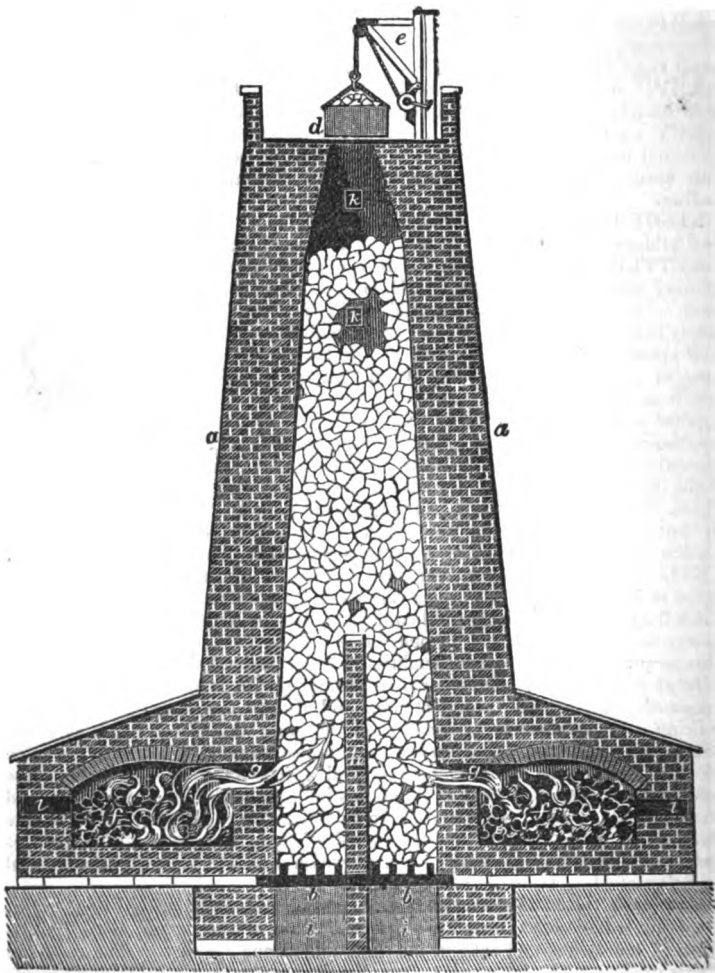


**KILN.** A structure or machine designed for drying substances by the application of heat. Their forms are as various as the substances or manufacture for which they are designed; for, although it may be said that a certain kiln will answer several purposes, yet for one single purpose we often find a variety of kilns employed. The requisite qualities in a good kiln are cheapness and durability of construction; effectiveness in producing the required result with the utmost economy of fuel; a perfect command of the temperature, and facility of working. Ovens must be regarded as of the same class of apparatus as kilns; indeed, the terms kiln and oven are often indiscriminately applied to the same structure, as may be noticed under several articles in this work. Under the head of **LIME** the usual form of lime-kilns is described; and under **COAL** and **IRON**, several forms of coke ovens. In this place we shall notice an admirable combination of both, which was the subject of a patent granted to Mr. Charles Heathorn about seven years ago, since which time it has been in successful operation at Maidstone and other places.

*Heathorn's Patent Combination of a Lime-kiln with a Coke-oven.*—The object of this invention, as expressed in the specification of the patent, is the preparation of quick-lime and coke in the same kiln at one operation. The economy of this process must be evident from the circumstance, that the inflammable part of the coal which is separated to form it into coke, is the only fuel employed to burn the lime; and as the coke is in many places as valuable as the coal from which it is prepared, the cost, if any, of making lime, must be reduced to the most trifling amount. The engraving on the following page represents a vertical section of the lime shaft and coke ovens: *aa* are the side walls, 4 feet thick, of a rectangular tower, the internal space being filled with lime-stone from the top to the iron bars *bb* at bottom, whereon the whole



column rests. The lime-stone is raised in a box *d*, or other proper receptacle, to the top of the building, by means of a jib and crane *e*, or other tackle, which is fixed at the back of the tower, together with a platform projecting beyond the walls for affording security and convenience for "landing" the lime-stone; when raised as represented, the jib is swung round, and the lime-box tilted, by which the whole contents are thrown down the shaft. The coke ovens, of



which there may be two, or a greater or lesser number, according to the magnitude of the works, are constructed and arranged in connexion with the lime shaft in the same manner as the two represented in the diagram at *ff*. These ovens are supplied with coal through iron doors in the front wall (not seen in the section); the doors have a long and narrow horizontal opening in the upper part of them to admit sufficient atmospheric air to cause the combustion

of the bituminous or inflammable part of the coal; the flames proceeding from these pass into the lime shaft through a series of lateral flues (two of which are brought into view at *g g*), and the draft is prevented from deranging the process in the opposite oven by the interposition of the partition wall *h*, which directs the course of the heat and flames throughout the whole mass of the lime, the lowermost and principal portion of which attains a white heat, the upper a red heat, and the intervening portions the intermediate gradations of temperature. When the kiln is completely charged with lime, the openings in front and beneath the iron bars at *i i* are closed and barricaded by bricks and an iron-cased door, which is internally filled with sand to effectually exclude the air, and prevent the loss of heat by radiation; therefore, when the kiln is at work, no atmospheric air is admitted but through the narrow apertures before mentioned in the coke oven doors. When the calcination of the lime is completed, the barricades at *i i* are removed, the iron bars at *b b* are drawn out, by which the lime falls down and is taken out by barrows. It sometimes happens, however, that the lime does not readily fall, having caked or arched itself over the area that encloses it, in which case a hooked iron rod is employed to bring it down. To facilitate this operation in every part of the shaft where it may be necessary, a series of five or six apertures, closed by iron doors, is made at convenient distances from the top to near the bottom of the shaft; two of these are brought into view at *k k*. Two similar apertures are shown in section in the coke ovens at *b b*, which are for the convenience of stoking and clearing out the lateral flues *g g* from any matter that might obstruct the free passage of the heated air. When the coals have been reduced to coke, the oven doors in front (not shown) are opened, and the coke taken out by a peel iron, the long handle of which is supported upon a swinging jib that acts as a movable fulcrum to the lever or handle of the peel, and facilitates the labour of taking out the contents of the oven. The operation of this kiln is continuous, the lime being taken from the bottom whenever it is sufficiently burned, and fresh additions of raw lime-stone being constantly made at the top.

*Kilns for Drying Corn.*—If air and moisture be carefully excluded from grain, it may be kept uninjured for an indefinite length of time. This is proved by an extraordinary experiment made with some Indian corn found in the graves of the ancient Peruvians, buried more than 300 years ago. Some of this corn being sown, it vegetated and came to maturity: we believe a similar fact is recorded respecting some grain found in the ruins of Herculaneum. But to preserve corn, even for a short period, it should be perfectly dry when housed, and carefully protected from dampness; but it not unfrequently happens, during a wet harvest season, that the corn is necessarily carried from the field in a damp state; and as few farmers have the means of properly and speedily drying it, large quantities are irrecoverably spoiled after all the labour and cost of production. The method of drying on the perforated floor of a kiln, (which is usually resorted to *where it can be obtained*), is a very tedious, defective, and expensive mode, and is attended with great labour, owing to the grain requiring to be continually turned over and spread by a workman, whose utmost care is insufficient to cause every part to receive an equal degree of heat; it therefore becomes a matter of considerable importance to devise a simple, efficacious, and economical method of drying grain under these circumstances, and we think Mr. Jones's apparatus for this purpose (shown in the engraving on the next page) is well adapted to the end proposed. *Fig. 1* is a vertical section of the apparatus, which is formed of two iron cylinders *a b*, placed one within the other, each being closed at the upper and lower end by two concentric cones *C D*. The annular space between the cylinders, as also between the cones, is an inch and a quarter in width, for the reception of the grain, to be dried by its passing through the machine; both the internal and external bodies are perforated throughout with about 2300 holes to the square foot. The kiln is supported on five cast-iron columns or legs, three of which are shown in the section as at *E*; these are attached to a strong iron ring which surrounds the base of the cylinder. From the heads of these columns descend, along the sides of the cone, five long bolts, as at *G*, which are passed through the same number of legs in

the cast-iron ring surrounding the neck of the lower cone: from this ring proceed five stays, as at I, which are fastened to the middle of the columns by a nut on each side. The body is sustained, both externally and internally, by iron hoops, as at K, and the distance between the cylinders is preserved by a number of short stays. In the front of the kiln a passage is cut out, as at O, in which is fixed the fire-place, through which are passages for the heated air to pass into the cylinder. These passages, as well as the flues, which proceed

Fig. 3.

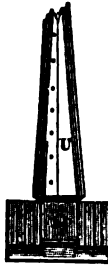


Fig. 2.

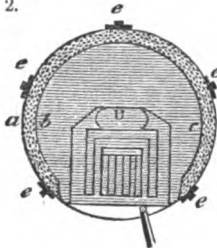
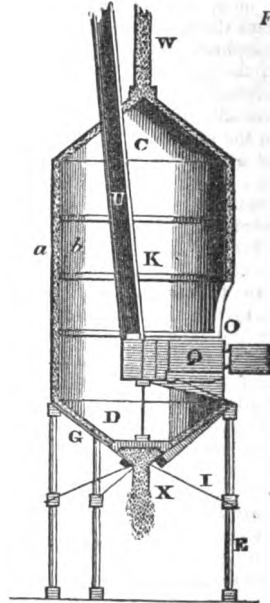


Fig. 1.

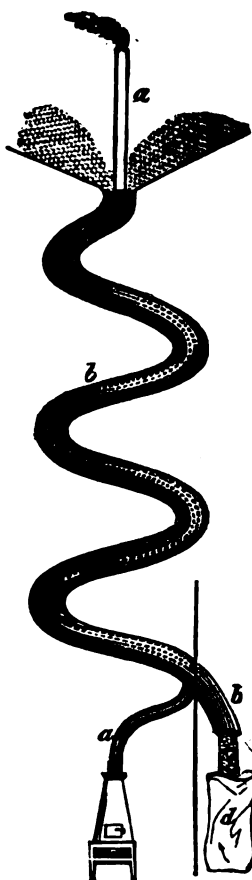


circuitously from the fire to the chimney, are best shown in the horizontal section, *Fig. 2*; and in the vertical section of the detached fire-place, *Fig. 3*, Q is the fire-hole, S the ash-hole, T the fire-bars, and U the chimney, which passes up nearly in the middle of the kiln. The wheat is admitted into the kiln from above through a hopper and through the tube W, and falling upon the apex of the cone is distributed equally on all sides between the cylinders, the little asperities in which, not only slightly retard the descent of the grain, but likewise impart to the particles, a constant, slow, rolling motion, whereby every individual grain is exposed to the same degree of temperature; the grain from thence converges into the lower cone, and ultimately escapes through the spout at bottom into sacks or on to the ground as may be required. The passage of the grain through the machine may be either accelerated or retarded, according to its peculiar condition, by enlarging or contracting the aperture through which it is discharged. The moisture is carried off by evaporation through the perforations of the plates with great rapidity. The kilns may of course be made of any dimensions; one of six feet internal diameter, and twelve feet in length, between the apexes of the upper and lower cones, has been said to be capable of perfectly drying more than 100 quarters of wheat in 24 hours.

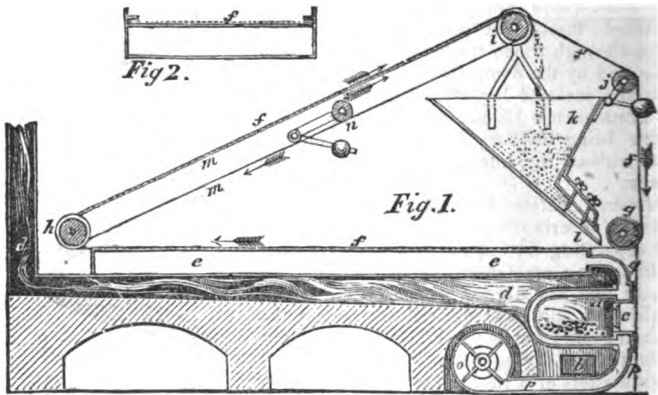
The following contrivance for drying grain has been noticed in several French papers, and announced as having been successfully adopted in one of

the departments; the plan, however, originated with a correspondent in the *Register of Arts*. The apparatus consists of a long spiral tube *a a* like a distiller's worm, reaching from the basement to the upper floor and through the roof of the granary, which forms a passage for the heated air from a close stove below. Externally round this tube is placed another tube *b b*, winding like the interior one in a spiral direction, and at about an inch and a half from it; this external tube receives the corn from above through a hopper *c*, and it is punched throughout with numerous small holes, through which the vapour escapes, as it is formed by the damp corn coming in contact with the inclosed heated chimney; the corn in consequence becomes thoroughly dried before being discharged at the bottom, and that without the intervention of any manual labour.

*Hebert's Patent Kiln*.—Under the article *Corn* is described an apparatus for washing and separating the impurities with which grain is always to a greater or less extent contaminated; and, as a necessary concomitant to that machine, a kiln was devised for drying the washed grain; but as this kiln is equally applicable to the drying of malt, seeds, and all other matters of a similar kind and form, and by a mode that is as novel as it is efficacious, we give a description of it in this place. In the engraving on the next page, *Fig. 1* exhibits a longitudinal section of the apparatus, and *Fig. 2* a transverse section of a long air-trough, shown at *e* in *Fig. 1*. At *a* is shown one of a series of five or six common iron gas tubes, placed side by side, and curved in the form represented to constitute a fire-place, the space between the tubes serving for the admission of air for combustion, which enters through the ash-pit door *b* at the side, provided with an air regulator: the fire-place is inclosed in front at *c* by a common door and frame. The heated air, and other products of combustion from the fuel, pass along the flue *d* to the funnel or chimney; the bottom and two sides of the flue *d* are of brick, but the top is of iron, being formed of the bottom of a long shallow iron box or air-trough *e*; this box has no cover but one of extremely open wove canvas, which forms a part of an endless cloth or band *fff*, that is continually made to travel lengthwise over the whole area of the said trough; the edges of the cloth gliding between grooves and over tie-rods, (shown in the cross section, *Fig. 2*, where the dotted line *f* indicates the endless cloth,) that prevent the cloth from sagging. This cloth is made to travel by the revolution of three rollers or drums *g, h, i*, to either of which the moving power may be applied. The cloth is kept distended by a self-acting tightening roller, which is screwed against the hopper *k*; this hopper receives the grain to be dried, and is provided with a shoe at *l*, adapted to deliver a thin and uniform stratum of grain upon the endless cloth, whilst the same is made to pass under it, and over the trough. Another endless band *m m*, of a similar fabric to the other, passes round the drums *h i* only, and is likewise provided with a self-acting tightening roller, fixable to any convenient object. The lower ends of the six tubes *a* of the fire-place before mentioned have an open



communication with a rotative blower *o*, by means of a broad channel *g*; and the upper ends of the tubes *a* also open into another broad channel *q*, which conducts the air into the long air-trough *e*. The operation of this machine is as follows. A slow rotation, derived from any first mover, is to be given to either of the drums *g*, *h*, *i*, which will cause the endless cloth *f* to glide gradually over the top of the air-trough *e*; at the same time the blower *o* has been put into action (by connexion with the first mover) at a high velocity, so as to produce a rapid current of air, which derives an increase of temperature on passing under the heated metallic bottom of the ash-pit; hence proceeding through



the tubes *a* it acquires considerable heat, which is subsequently moderated by an extensive diffusion in the air-trough *e*, before it passes through the meshes of the endless cloth *h* above, carrying with it the moisture from the grain deposited thereon. The course taken by the endless cloth is shown by arrows in the figure; upon its arriving at the drum *h*, the other endless cloth *m* comes in contact with the grain on the cloth *f*, and upon both the cloths passing round the said drum *h*, the corn becomes inclosed between the two cloths, and is thus carried up an inclined plane over the drum *i*, where the cloths separate, and discharge the grain back again into the hopper *k*, to undergo a repetition of the operation, should it not be perfectly dry. But when the grain is thoroughly dried, instead of allowing it to fall back into the hopper, a shoot, or the band of a creeper, (not shown in the drawing,) is brought under the roller *i*, which conducts it to the required place. A very little experience in the working of this apparatus enables a person so to regulate its operations as to complete the drying of damp grain by a single passage through it; such as varying the velocity of the air-forcer, the quantity of fuel in the stove, the supply of air through the ash-pit, the speed of the endless cloth, &c. the means of doing which are so well understood by mechanics as to render a description of them unnecessary in this place.

**KITE.** A fictitious bird, made of paper. This well-known juvenile plaything has been of late years applied to several objects of utility: the foremost of these, and the most paramount in importance, is the invention of Captain Dansey, for effecting a communication between a stranded ship and the shore, or, under other circumstances, where badness of weather renders the ordinary means impracticable. The following is an abbreviated description of the invention, extracted from the forty-first volume of the *Transactions of the Society of Arts*, where the subject is given more in detail, with engraved illustrations:—A sail of light canvas or holland is cut to the shape, and adapted for the application of the principles of the common flying kite, and is launched from the vessel or other point to windward of the space over which a commu-

nication is required; and as soon as it appears to be at a sufficient distance, a very simple and efficacious mechanical apparatus is used to destroy its poise and cause its immediate descent, the kite remaining however still attached to the line, and moored by a small anchor with which it is equipped. The kite, during its flight, is attached to the line by two cords placed in the usual manner, which preserves its poise in the air; and to cause it to descend, a messenger is employed, made of wood, with a small sail rigged to it. The line being passed through a cylindrical hole in this messenger, the wind takes it rapidly up to the kite, where, striking against a part of the apparatus, it releases the upper cord, and by that means the head of the kite becomes reversed, and it descends with rapidity. In the experiments made by Capt. Dansey, with the view of gaining communication with a lee-shore, under the supposition of no assistance being there at hand, a grapnel, consisting of four spear-shaped iron spikes was fixed to the head of the kite, so as to moor it in its fall, and in this emergency, the attempt of some person to get on shore along the line, would be the means resorted to. In those cases where a communication has been gained, and the maintenance of a correspondence has been the object, the person to windward has attached a weight to the messenger, in some cases as much as three pounds, which, having been carried up, has of course descended with the kite; the person to leeward has then furled the sail of the messenger, and loaded it with as much weight as the kite could lift; then replacing the apparatus, and exposing the surface of the kite to the direct action of the wind, it has rapidly risen, the messenger running down the line to windward during its ascent. The kite with which Capt. Dansey performed the greater part of his experiments, extended 1100 yards of line, five-eighths of an inch in circumference, and would have extended more had it been at hand. It also extended 360 yards of line,  $1\frac{1}{4}$  inch in circumference, and weighing 60 lbs.; the holland weighed  $3\frac{1}{2}$  lbs; the spars, one of which was armed at the head with iron spikes, for the purpose of mooring it,  $6\frac{1}{2}$  lbs.; and the tail was five times its length, composed of 8 lbs. of rope and 14 lbs. of elm plank. A complete model of the apparatus was deposited with the Society, who presented Capt. Dansey with their gold Vulcan medal for his invention and communication.

Messrs. Viney and Pocock have also recently applied a kite for the drawing of a carriage, in which they travelled from Bristol to London. See Vol. I. page 323.

KNEADING is the process of making the stiff paste of flour and water for being afterwards baked into bread. It is usually effected by a sort of pommeling action of the hands and arms, and sometimes of the feet of the bakers. A variety of machines have been at different times proposed for superseding the barbarous process we have just mentioned; they have however been but very partially adopted, the bakers in general preferring to continue their "good old-fashioned" dirty practice. "*Pain à la mécanique*" is, however, fashionable in Paris, and, it is to be hoped, will ere long become so here. It is said that at Geneva all the bakers of that city are compelled by law to send their dough to be kneaded at a public mill constructed for that purpose. At Genoa, also, mechanism is employed for kneading; the apparatus employed at this place has been published in several of the journals, from which it appears to be so rude and ill-contrived as not to need a description in this place.

1. The *petrisseur*, or mechanical bread-maker, invented by Cavallier and Co. of Paris, seems to us to be nearly the best hitherto introduced. This consists of a strong wooden trough, nearly square, with its two longest sides inclined, so as to reduce the area of the trough in the direction of its width, and adapt it to the dimensions of a cast-iron roller, the axis of which passes through the ends of the trough; the bottom of the trough is semi-cylindrical, leaving a small space between it and the roller, which space is adjustable by levers. All along the top of the outside of the roller, is fixed a knife edge, which, with the roller, divides the trough into two compartments. Upon the axis of the roller is a toothed wheel, which takes into a pinion; this pinion is turned by a winch, and communicates thereby a slower motion to the roller, and the roller, by its rotation, forces the materials or dough through the narrow space before mentioned, both between it and the bottom of the trough; the knife edge on the top of the

roller preventing the dough from passing by it. Being thus all forced into one of the compartments, the motion of the roller is reversed by turning the winch the contrary way, which then forces the dough back again through the narrow space under the roller into the first compartment; in this manner the working of the dough, alternately from one compartment to the other, is continued until completed.

2. Another plan was to make the trough containing the dough revolve with a number of heavy balls within it. The trough in this case is made in the form of a parallelepipedon, the ends being square, and each of the sides a parallelogram, whose length and breadth are to each other as five to one. One side of the trough constitutes a lid, which is removed to introduce the flour and water, and the trough is divided into as many cells as there are balls introduced. The patentee states, that by the rotation of the trough the balls and dough are elevated together, and by their falling down the dough will be subjected to beating, similar to the operations of the baker's hands.

3. Instead of employing a revolving cylinder, it is fixed, an agitator is made to revolve, having a series of rings angularly attached to an axis, extending the whole length of the trough.

4. Mr. Clayton, a baker of Nottingham, had a patent in 1830 for a machine somewhat similar to the last mentioned, inasmuch as a set of revolving agitators are employed to produce the kneading action; the agitators are longitudinal bars, fixed to arms, which radiate from the axis, and they are forced through the dough in their revolution; but the cylinder in which they revolve, and which contains the materials, is made to revolve at the same time in a contrary direction; the motion of the latter being imparted by a short hollow axis, while the axis of the former is solid and passed through the hollow one. The solid axis, which is turned by a winch, has on it a bevelled pinion, which, by means of an intermediate bevelled wheel, actuates another bevelled pinion fixed on the hollow axis, and therefore causes it to revolve in the opposite direction. These two simultaneous and contrary motions constitute the novelty claimed by the patentee, who states, that dough-making machines, similar to his own, have all failed for want of such an arrangement. This statement, coming from a baker, commands attention; but we cannot concur in its truth, since we know that the following plan of a kneading machine works well without opposite simultaneous motions, and without any agitators or beaters, which absorb a great deal of power without producing an adequate effect.

5. *Hebert's Patent Kneading Machine.*—In this a cylinder of from 4 to 5 feet in diameter, and only about 18 inches wide inside, is made to revolve upon an axis, which is fixed by a pin during the revolution of the cylinder. The flour is admitted by a door in the periphery, which closes air and water-tight; and the water or liquor passes through a longitudinal perforation in the axis, and thence through small holes amongst the flour, in quantities which are regulated externally by a cock. By the rotation of the cylinder the dough is made to be continually ascending on one side of it, whence it falls over upon the portion below. When the mixture becomes pretty intimate and uniform, its adhesive property causes it to stick to the sides of the cylinder, and the dough would then be carried round without much advancing the process, were it not for another simple contrivance: this is a knife-edge or scraper, 18 inches long, which is fixed along the top of the cylinder in the inside, so as barely to touch its surface; the knife is fixed to two flat arms extending from the axis, and these arms have sharp edges so as to scrape the sides of the cylinder; thus the cylinder is kept constantly clean from the sticking of the dough, which, as soon as it ascends to the top of the cylinder (if it does not tear away of itself) is shaved off by the knife, and falls down with great force upon the bottom; and as this effect is constant during the motion of the cylinder, it must be evident that the process of kneading is soon completed by it. When that is done, the door of the cylinder is opened, and the contents discharged into a recipient beneath; at which time the scraper is caused, by a winch on the axis, to make one revolution of the now fixed cylinder, which clears off any adhering dough, and projects it through the door-way. As the dough in this machine may be

said to knead itself, there being no arms, beaters, or agitators whatever, it is calculated that the power saved by it is very considerable, while, from the simplicity of its construction, the cost is moderate.

The patentee is at present engaged in combining with this kneading machine an apparatus for preparing carbonated water, highly charged with the gas, with which he proposes to mix up the flour to form dough, for the purpose of making the bread spongy or vesicular, without having recourse to the fermentative process; the result of which process, under the most favourable circumstances, he considers to be detrimental to the health of those that eat the bread, (owing to the deposition of fermentable matter in the stomach,) while it is destructive of a portion of the nutriment of the flour.

**KNIVES (including Forks).** Knives are well-known instruments, made for cutting a great variety of substances, and adapted by differences in form to various uses; but the two principal sorts may be classed under the terms of pocket-knives and table-knives, with their now necessary accompaniments, forks. The manufacture of these articles in this country is almost wholly conducted at Sheffield. Our account of the process of making them must necessarily be concise, and afford only a glimpse of the procedures, as it is manifestly impossible for us to transform the uninitiated into cutlers by any information that we can give.

In the making of pocket-knife blades, one workman and a boy are generally employed; the boy attends to the heats, (that is, to the rods of steel in the fire,) which he successively hands to the forger, and takes back the rod from which the last blade was formed. One heat is required to fashion the blade, and a second to form the tang, by which it is fastened into the handle. The skill of the forger is displayed in forming it so perfectly by his hammer, as to require but very little to be filed or ground off in the subsequent operations. The springs for the back of the knife, and the scales which form the rough metal under-handle, and to which the other pieces are rivetted, are made by a distinct class of workmen. In the forging of table-knife blades, and other blades of a similar or greater size, the forger has an assistant, who, with a large hammer, strikes alternately with him; and the hammering of all blades is continued after the steel has ceased to be soft, in order to condense the metal and render it very smooth and firm. Table-knife blades are usually made with iron backs, which are welded to the steel by a subsequent forging, to that of forming the cutting edge; the thick piece that joins the handle, called the shoulder or bolster, as well as the tang that goes through the handle, is forged out of the iron immediately after the welding of the steel blade: dies and swages being employed to perfect and accelerate the shaping of these parts. When the forging is completed, the blades undergo the processes of hardening and tempering, already explained in our account of the steel manufacture (article IRON). The blades are then ground upon a *wet* stone, about 4 feet in diameter, and 9 inches wide, which roughs out the work; they are subsequently finished or *whitened*, as it is termed, upon a finer *dry* stone; and the shoulders or bolsters are ground upon a narrow stone, about 3 feet in diameter, which completes the grinding. The next process is that of glazing the blades, which is effected upon a wooden wheel, made up of solid segments, well fitted and secured together, and with the ends of the fibres of the wood presented to the periphery of the circle; over this is extended a piece of leather, which is charged with emery or other powder, adapted to the finish or nature of the work required.

It is only about 200 years since, that table-forks were known in England, when they were introduced from Italy; and even now, in some remote parts of Scotland and Ireland, they are regarded as useless articles of luxury. The cheaper kind of forks are made by casting them from malleable pig-metal, (see IRON,) sometimes denominated "run-steel;" and some of these, which are well annealed and worked under the hammer, turn out very serviceable and good. Those made of wrought metal, were formerly either forged, and the prongs drawn out by the hammer, and welded together, or they were forged into one solid piece, and the spaces between formed by cutting away the metal. These processes, however, were tedious and expensive, and a great improvement in

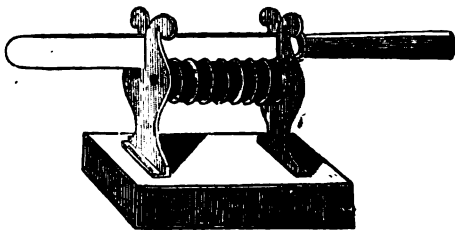


their manufacture has been introduced. The tang, shoulder, and a thick, flat piece, called the blade, are forged, and the blade is then submitted to the action of a pair of dies, contained in a powerful fly or stamping-press; the dies being so formed as to force or cut out the superfluous portion of the metal and raise the curved swelled portions at the junction of the prongs, termed the bosom. The forks after this operation are filed up, ground, glazed, and burnished, when they are ready for hafting, which is a distinct business.

The instruments required for hafting knives and forks are few and simple. The principal are, a small polishing wheel and treddle, mounted upon a stand, a bench vice, and a kind of hand vice to fix in the bench vice, termed a snap-dragon; it has a pair of long projecting jaws, adapted to hold a piece of metal or other substance, with the flat side uppermost, in order to be filed or otherwise worked; a few files, drills, drill-box, and breast-plate, burnishers and buffs, emery, rotten stone, &c. The substances used for covering the handles are almost infinite; the chief are bone, horn, ivory, tortoiseshell, and wood of every kind. The several pieces of the handle being filed to the shape intended, holes are drilled through them for the pins by which they are afterwards rivetted together. The pinning is at first loosely done; until the blades, springs, and all the parts are well adjusted and fit closely, they are then firmly rivetted together. The handles are afterwards scraped and then polished, by means of buffing, on the wheel.

**KNIFE-SHARPENERS.** This term has been given to a variety of convenient modern instruments, especially adapted to the sharpening of knives at table, but particularly carvers, and are intended as substitutes for the common steel. For these instruments several patents have been obtained, and a considerable manufacture of them has been established.

*Filton's Patent Sharpener*, without its usual accompanying ornaments, is represented in the annexed cut; it consists of two horizontal rollers, placed parallel to each other, which revolve freely upon their axes, (represented by the two black dots;) at uniform distances, there are fixed upon each roller, narrow cylinders or rings of hard steel, the edges of which are cut into fine teeth, and thus form circular

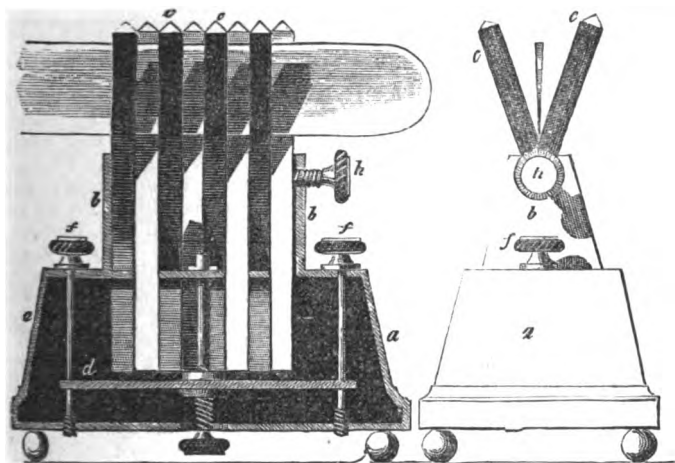


files; the edges of the files in the opposite rollers overlap each other a little, so that when a knife is drawn longitudinally between them, the edge of the knife is acted upon on both of its sides at once. The rollers turn round with the slightest impulse, consequently, they wear uniformly, and will last a considerable time. A good edge is given to a knife by just drawing it from heel to point two or three times between the rollers; and thus obviates the necessity of imitating the skill exercised by a butcher upon his steel.

*Westby's Knife-sharpener*, which was patented in 1828, is a very pretty and ingenious instrument; an immense quantity of them have been sold, and it is said, have been the means of greatly enriching the proprietor of the patent. In the engraving on the next page, *Fig. 1* exhibits an end elevation of the instrument, and *Fig. 2* a side elevation of the bars, with a section of the boxes *a* and *b*, to show the interior. The same letters in each figure have reference to similar parts; *a* is a small oblong box, surmounted by a smaller box *b*; in the top of the latter there is a slit made throughout its length, and of sufficient width to receive the square steel bars *c c*. The box *a* has two similar slits. The surfaces of the bars are draw-filed, they pass through the slit in *b*, and alternately through both slits in *a*, so as to cross each other, as shown in *Fig. 1*. The lower ends of these bars are supported upon a plate of metal *d*, which can be elevated, so as to bring a different portion of the bars into operation, by means of the screw underneath; *f f* are two screws passing through the holes

in *d*, to preserve its parallel motion, and likewise to support the bottom of the box; *h* is a tightening screw to steady the bars *c c*.

The mode of operating with this instrument is merely to place the edge of the knife upon the bars, so as to bisect the angle formed by them, and then



draw the knife backward and forward. As the surfaces of the bars wear away, different sides can be presented, or they can be shifted from end to end, so as to present fresh surfaces to the knife.

*Church's Patent Knife-sharpener* consists of two very flat truncated cones, fixed with their smaller surfaces together, and with several rectangular projections in the one, fitting into similar cavities in the other. The conical surfaces of both pieces are serrated with a series of very fine teeth extending angularly towards their centres; these are placed upon the shank of the fork, between the shoulder and the handle, with which they correspond in diameter so nearly as to constitute an ornamental finish to the small end of the handle. In the position and size of these consist the principal merit of the sharpener. When used for sharpening scythes, or other large cutting instruments, the conical pieces are made larger, and fitted on an axis between two prongs of a forked apparatus, with an appropriate handle.

*Westby's second Patent.*—The extraordinary success attendant upon Mr. Westby's contrivance for sharpening table-knives induced him to figure a second time as a patentee, "for certain improved apparatus to be used for the purpose of whetting or sharpening the edges of the blades of *penknives, razors, and other cutting instruments.*" The first improvement mentioned in the specification consists in the application to a hone, or oil-stone, of a guide to keep the edge of the razor, or other cutting instrument, at the same angle with respect to the surface of the hone, during the operation of whetting. This is effected in two ways; first, by placing over the hone a plate of metal extending its whole length, and adjustable, at any required distance parallel to its surface, by set screws; now, in the operation of sharpening, the back of the instrument is kept resting upon the guide-plate, while the edge is applied to the hone. The second method consists in the application of two hones placed in an erect position, with a space between them for the razor, which is to be fixed by screws into a small horizontal frame, made to slide upon a circular rod, so that the edge can be applied alternately to the hones; these can be elevated and depressed at pleasure, so that their surfaces may be uniformly worn while in use. The patentee also mentions in his specification a method of attaching to his hone a leather strap which is made double, and kept stretched by adjusting screws attached to the frame of the hone, or else to the end of a rod extending

lengthways between the two folds of leather. This last contrivance does not appear to us to be scientifically adapted to the object in view, as the pressure of the edge of the instrument upon a strap of leather only supported at its extremities, must produce a tendency in the leather to wrap round the acute angle of the edge of the instrument, and render it obtuse.

## L.

**LABORATORY.** A place fitted up and supplied with the necessary apparatus for chemical operations. Laboratories for conducting chemical processes on a large manufacturing scale will of course vary in their arrangements according to the main object for which they are designed. For experimental and general purposes a laboratory is more advantageously placed above than below ground, that it may be as dry as possible; the air must have free access to it; and it must even be so constructed that, by means of opposite openings, a current of air may be admitted to carry off noxious vapours. A chimney ought to be constructed so high that a person may easily stand under it, and extending the length of one of the side walls. The chimney should be high, and sufficiently contracted to make a good draught. When charcoal is the only fuel to be employed no soot will be deposited, and therefore it need not be so wide as to allow a chimney-sweeper to pass up it. Under this chimney may be constructed some brick furnaces, particularly a melting furnace, a furnace for distilling with an alembic, and one or two ovens like those in kitchens. The rest of the space ought to be filled up with stands of different heights, from a foot to a foot and a half, on which portable furnaces of all kinds are to be placed. These furnaces are the most convenient, from the facility of disposing of them at pleasure; and they are the only furnaces which are necessary in a small laboratory. A double pair of bellows of moderate size must also be placed as commodiously as possible under or near to the chimney, and having a pipe directed towards the hearth where the forge is to be placed. The necessary furnaces are the simple furnace, for distilling with an alembic, a lamp furnace, two reverberatory furnaces of different sizes for distilling with retorts; an air or melting furnace, an assay furnace, and a forge furnace. Under the chimney, at a convenient height, should be a row of hooks driven into the back and side walls, upon which are to be hung small shovels, iron pans, tongs, pincers, pokers, and various utensils for disposing the fuel and managing the crucibles. To the walls of the laboratory should be fixed, or suspended, rows of shelves, of different breadths and heights, for containing bottles and glass vessels, which should be as numerous as is possible, that the products of operations may be conveniently retained. The most convenient place for a stone or leaden cistern to contain water, is a corner of the laboratory, and under it a sink ought to be placed, with a pipe by which the water poured into it may discharge itself. As the vessels are always cleaned under this cistern, cloths and bottle-brushes ought to be hung upon hooks fastened in the walls near it. In the middle of the laboratory a large table is to be placed, on which mixtures are to be made, preparations for operations, solutions, precipitations, small filtrations; in short, whatever does not require fire, excepting that from a lamp. In convenient parts of the laboratory are to be placed blocks of wood upon mats, one of which is to support a middle-sized iron mortar, another a support for a middle-sized marble, or hard stone mortar, and a third for an anvil. Near to the mortars are to be hung sieves of different fineness and sizes; and near to the anvil, files, rasps, pincers, shears, and other convenient utensils for working metals, or giving them proper forms for the several operations; two movable trestles, to support a large filter or other apparatus, that they may be disposed of conveniently. On account of the dust from charcoal, the stock of this article had better be placed contiguous, but not inside the laboratory; also some dried furze or other quick burning fuel. In the same place may be put bulky articles, bricks, tiles, clay, lime, sand, and many other things useful in chemical operations. A small, solid table, for a levigating stone and muller; small mortars, of iron, glass, agate, and

Wedgwood ware ; earthen, stone, metal, and glass vessels of different kinds ; funnels, measures, glass-tubes ; spatulas of wood, metal, ivory, and glass ; pasteboards, writing paper, unsized paper, clean straws, horns, corks, bladders, linen strips, lutings, cements, paste, glue, portable bellows, brushes, boxes, &c. &c. are all occasionally wanted in a laboratory. See *Ure's Dictionary of Chemistry*.

LAC. A resinous substance, the product of an insect found on several different kinds of trees in the East Indies. These insects pierce the small branches of the trees on which they feed ; and the juice that exudes from the wounds is formed by them into a kind of cells for their eggs. Lac is imported into this country adhering to the branches in small transparent grains, or in semi-transparent flat cakes. The first, encrusting the branches, is called stick-lac ; the second (are the grains picked off the branches, and called seed-lac ; the third is that which has undergone a simple purification, as we shall presently notice. There is a fourth called lump-lac, made by melting the seed-lac, and forming it into lumps. To purify the lac for use the natives of India put it into long canvas bags, which they heat over a charcoal fire until the resin melts ; a portion of the lac then exudes through the bags, which are subsequently twisted, or wrung by means of cross sticks at the ends of the bags, the surface of the latter being scraped at the same time to accelerate the process. The chief consumption of lac in this country is in the manufacture of sealing-wax and varnishes. It has been a great desideratum among artists to render shell-lac colourless, as, with the exception of its dark brown hue, it possesses all the properties essential to a good spirit varnish in a higher degree than any other known resin. A premium of a gold medal, or thirty guineas, for " a varnish made from shell or seed-lac, equally hard, and as fit for use in the arts," as that at present prepared from other substances, was offered for some years by the Society of Arts. The editor of the *Franklin Journal*, of Philadelphia, observes, in reference to the foregoing, that " these ends are perfectly attained by the process given by Dr. Hare, which leaves nothing to desire, excepting on the score of economy." Were the oxymuriate of potash to be manufactured in the large way, the two processes, that of making the salt and of bleaching the resin, might be advantageously combined. " Dissolve," (says Dr. Hare,) " in an iron kettle, one part of pearl-ash in about eight parts of water ; add one part of seed or shell-lac, and heat the whole to ebullition ; when the lac is dissolved, cool the solution, and impregnate it with chlorine till the lac is all precipitated. The precipitate is white, but its colour is deepened by washing and consolidation ; dissolved in alcohol, lac bleached by the process above-mentioned yields a varnish which is as free from colour as any copal varnish." About the same period of time as the publication of the foregoing, the before-mentioned premium of the Society of Arts was claimed by two persons, Mr. George Field, and Mr. Henry Luning. The Society, upon a due examination of both of the processes and products, found them both to answer the intended purpose, and awarded the sum of twenty guineas to each of the candidates.

The following is Mr. Field's process : Six ounces of shell-lac, coarsely powdered, are to be dissolved by gentle heat in a pint of spirits of wine ; to this is to be added a bleaching liquor, made by dissolving purified carbonate of potash, and then impregnating it with chlorine gas till the silica precipitates, and the solution becomes slightly coloured. Of this bleaching liquor add one or two ounces to the spirituous solution of lac, and stir the whole well together ; effervescence takes place, and when this ceases, add more to the bleaching liquor, and thus proceed till the colour of the mixture has become pale. A second bleaching liquor is now to be added, made by diluting muriatic acid with thrice its bulk of water, and dropping into it pulverized red lead, till the last added portions do not become white. Of this acid bleaching liquor, small quantities at a time are to be added to the half bleached lac solution, allowing the effervescence, which takes place on each addition, to cease before a fresh portion is poured in. This is to be continued until the lac, now white, separates from the liquor. The supernatant fluid is now to be poured away, and the lac is to be well washed in repeated waters, and finally wrung as dry as possible in a cloth.

The lac obtained in the foregoing process is to be dissolved in a pint of alcohol, more or less, according to the required strength of the varnish; and after standing for some time in a gentle heat, the clear liquor, which is the varnish, is to be poured off from the sediment.

Mr. Luning's process is as follows:—Dissolve five ounces of shell-lac in a quart of rectified spirits of wine; boil for a few minutes, with ten ounces of well-burnt and recently heated animal charcoal, when a small quantity of the solution should be drawn off and filtered; if not colourless, a little more charcoal must be added. When all colour is removed, press the liquor through silk, as linen absorbs more varnish, and afterwards filter it through fine blotting-paper. In cases where the wax found combined with the lac is objectionable, filter cold; if the wax be not injurious, filter while hot. This kind of varnish should be used in a temperature of not less than 60° Fahr.; it dries in a few minutes, and is not afterwards liable to chill or bloom; it is therefore particularly applicable to drawings and prints which have been sized, and may be advantageously used upon oil paintings which have been painted a sufficient time, as it bears out colour with the purest effect. This quality prevents it from obscuring gilding, and renders it a valuable leather varnish to the book-binder, to whose use it has already been applied with happy effect, as it does not yield to the warmth of the hand, and resists damps, which subject bindings to mildew. Its useful applications are very numerous, indeed, to all the purposes of the best hard spirit varnishes: it is to be used under the same conditions, and with the same management. Common seed-lac varnish is usually made by digesting eight ounces of the bright, clear grained lac in a quart of spirits of wine, in a wide-mouthed bottle, putting it in a warm place for two or three days, and occasionally shaking it. When dissolved it may be strained through flannel into another bottle for use. In India, lac is fashioned into rings, beads, and other trinkets. Its colouring matter, which is soluble in water, is employed as a dye. The resinous portion is mixed with about three times its weight of finely powdered sand, to form polishing stones. The lapidaries mix powder of corundum with it in a similar manner.

LACQUERING is the application of transparent or coloured varnishes to metals, to prevent their becoming tarnished, or to give them a more agreeable colour. The basis of them is properly the lac described in the preceding article; but other varnishes made by solutions of other resins, and coloured yellow, also obtain the name of lacquer. Strictly speaking, lacquer is a solution of lac in alcohol, to which is added any colouring matter that may be required to produce the desired tint; but the recipes that have been published in various scientific journals contain apparently a great many useless articles. The following is much extolled, in *Nicholson's Operative Mechanic*, as a lacquer for philosophical instruments:—

½ oz. of gum guttæ.	½ oz. of terra merita.
2 oz. of gum sandarac.	2 oz. of oriental saffron.
2 oz. of gum elemi.	3 oz. of pounded glass;
1 oz. of dragon's blood, of the best quality.	and
1 oz. of seed lac.	20 oz. of pure alcohol.

Before, however, the reader ventures to meddle with so formidable a list of ingredients as the foregoing, we would recommend him to make trial of the following more simple compound:—Take 8 oz. of spirits of wine, and 1 oz. of annatto, well bruised; mix these in a bottle by themselves: then take 1 oz. of gamboge, and mix it in like manner with the same quantity of spirits. Take seed-lac varnish, (described under the previous article *Lac*,) what quantity you please, and colour it to your mind with the above mixtures. If it be too yellow, add a little from the annatto bottle; if it be too red, add a little from the gamboge bottle; if the colour be too deep, add a little spirits of wine. In this manner you may colour brass of any desired tint: the articles to be lacquered may be gently heated over a charcoal fire, and then be either dipped into the lacquer, or the lacquer may be evenly spread over them with a brush.

LACE. A delicate kind of net-work, composed of silk, flax, or cotton threads, twisted or plaited together. The meshes of this kind of net are of a

pentagonal figure, in which thick threads are also woven to form the pattern according to some design; and these threads, which are called gyp, form the ornament of the lace. Buckinghamshire and Bedfordshire have been for many years the counties most celebrated for the manufacture of the pillow or bobbin lace, so called because it is woven by women or children upon a pillow or cushion, by means of bobbins, (which are made of ivory or bone, and each of which contains a small quantity of fine thread,) in such a manner as to make the lace exactly resemble the pattern, which is fixed upon a large round pillow, and pins being stuck into the holes or openings in the pattern, the threads are interwoven by means of the bobbins. At the close of the last century, the manufacturers of Nottingham directed their ingenuity to imitate this species of lace by machinery, in which they have completely succeeded. The Nottingham imitations of lace are of two kinds—point-net and warp-net. The point-net frame is a variety of the stocking frame, which was invented by Mr. John Morris, of Nottingham, in 1764; but it was not at first used to make lace, being intended to make the ankle part of stockings. The machine is an addition to a stocking frame, and operates on the thread in the same way as in stocking weaving for a great part of the process. The Nottingham lace, therefore, is only a modification of the stitch or loop of which stockings are made; all the meshes being formed by a continuance of one thread, which is by the machine formed into loops, a whole course at once, by pressing it down alternately over and under between a number of parallel needles; a second course is then made of similar loops on the same needles, and the loops of the first are drawn through those of the second in such a manner as to form meshes by retaining the first loops; the second are then retained by a third course, and this by a fourth, and so on. The warp-net frame is also a variety of the stocking frame, but the parts are very differently arranged, the movements being produced by treadles, leaving the hands of the workman to manage the machine, which is a piece of mechanism applied in front of the row of needles of the frame. In the warp frame the piece of lace is not formed of one continued thread, as in the point-net frame, but there are as many different threads as there are needles in the frame; these threads are warped, or wound upon a roller or beam the same as a loom; and it is from this circumstance that the machine is called a warp frame. These threads pass through eyes in the ends of small points, called guides, which are opposite the needles; and these guides are fixed on two bars, each of which has half the guides fastened on it; that is, one guide is fast in one bar, and the next in the other, and so on alternately of the whole. Each of the guides presents a thread to its needle, and are all at once moved by the hand to twist the threads two or three times round the needles which are opposite them: the loop is now made in a manner similar to the other frame. The next time, the alternate guides are shifted endways, so as to apply themselves to other needles than those they were opposite before: this crosses the thread so as to make a net; but the quantity which is shifted endways is altered every time, by means of the machinery, so as to move a certain number of needles, which number is altered every time to produce the pattern. In 1809, Mr. John Heathcoat invented a machine for weaving the real twisted lace, like that which is made on the pillow. The ground-work of the invention is to extend those threads which form the warp of the lace in parallel lines, and dispose the diagonal threads upon small bobbins, which are detached, and are capable of passing round the extended warp threads, so as to twist with them; by this means, the number of bobbins is reduced to one half. In this machine there are two horizontal beams or rollers, one to contain the thread, and another to receive the lace; also a number of small bobbins to contain the thread.

Since Mr. Heathcoat's first invention, the manufacturers of Nottingham, Leicester, Tewkesbury, and many other places, have vied with him and each other in the production of lace-making machinery. In 1824 the different descriptions of machinery for making lace were enumerated under the following heads:—the old Loughborough double tier, *Heathcoat's*; the single tier on *Stimson's* principle; improved double tier, *Brailey's*; single tier on *Lever's*

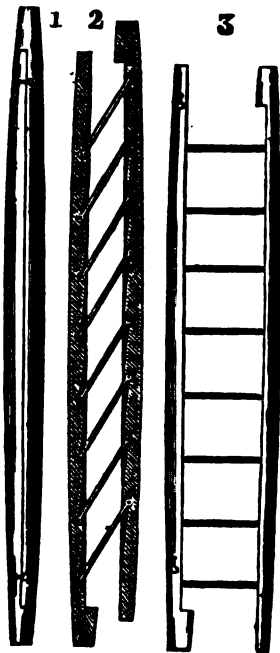
principle; the old Loughborough improved, with pumping tackle; the pusher principle; the traverse warp, *Bevan and Freeman's*; traverse warp rotatory, *Lindley and Lacey's*; the straight bolt, *Kendal and Mauley's*; the circular bolt, *Mauley's*; the circular comb, *Hervey's*; the circular comb improved, *Hervey's*; and the improved *Lever's*. The foregoing comprehend the different principles upon which the machinery for making bobbin-net lace have been founded.

In 1824 Mr. Longford took out a patent for actuating several of the foregoing machines by rotatory motion, which were previously worked by a beating or lever action of the hands and feet of the operator. Since the last-mentioned period there have been a great many patents taken out for improvements, the description of which alone would occupy a large volume, and require some hundreds of engravings to render them intelligible. We can therefore only refer the reader to such works as are distinguished by subjects of this nature,—viz. *The London Journal of Arts, The Repertory of Arts, the Register of Patent Inventions*, and to the enrolled specifications,—for such further information that he may require.

**LACTOMETER.** An instrument invented by Mr. Dicas, of Liverpool, for the purpose of ascertaining the different qualities of milk from its specific gravity compared with water. On this subject Dr. Ure observes, that it is not possible to infer the quality of milk from the indications merely of a specific gravity instrument, because both cream and water affect the specific gravity of milk alike. "We must first use as a lactometer a graduated glass tube, in which we note the thickness of the stratum of cream afforded, after a proper interval, from a determinate column of new milk; we then apply to the skimmed milk a hydrometric instrument, from which we learn the relative proportions of curd and whey. Thus the combination of the two instruments furnishes a tolerably exact lactometer."

**LADDER.** A portable frame, containing steps for the feet. There are various kinds, most of which are too familiar to the readers of this work to need description; but there is one of a very ingenious description, described under the head of **FIRE ESCAPES**, invented by Mr. Gregory, which is evidently applicable to a great variety of purposes, wherein common ladders are useless, or of difficult employment. Ladders are very advantageously employed in the raising of weights, by the addition of a pulley-wheel at the top, or suspended over them; passing over this pulley is a rope, to one end of which is attached the article to be raised, (a tea-chest, for instance, out of the hold of a ship;) a man then ascends the ladder to the required height, and steps on to a foot-board, properly contrived for the purpose, which is attached to the other end of the rope just mentioned; the man's weight, then, more than counterpoising the tea-chest, he rapidly descends, while the chest ascends through the same space. In this manner the tea is unloaded from the East India Company's dock at Blackwall, and it is very probable there is not a more efficient mode of applying a man's labour for that purpose, and the mechanism is cheap, convenient, and easily adjustable to the space. The man has only to ascend the steps of the ladder, and he is refreshed in the descent, the frame in which he stands sliding over the inclined plane of the ladder.

Mr. W. Hilton has likewise ingeniously



converted the fixed ladder against a trap door, into a crane for lowering heavy or bulky articles, such as a pipe of wine from a warehouse into a cellar, for the communication of which invention to the Society of Arts Mr. Hilton was rewarded by an honorary medal.

A very convenient folding ladder is manufactured by Mr. Green, of Goswell-street, of which the cut in the preceding page is a representation. *Fig. 3* shows the ladder as opened out for use; *Fig. 2* shows the ladder in section, half open, and the manner in which the rounds are jointed to the side rails; and *Fig. 1* exhibits the ladder folded up close, forming exteriorly a round pole, tapered at each end. Mr. Green has likewise contrived an excellent ladder for the purpose of rescuing persons who may have the misfortune to sink under ice.

**LAKE.** A name given to several pigments formed by precipitating colouring matter with some earth or oxide. The principal lakes are carmine, Florence lake, and madder lake; the first of these has been already described under its initial letter. See **CARMINE**.

Florentine lake is prepared from the sediment of the cochineal, which is deposited in the preparation of carmine, and the red liquor also remaining from the same; these are boiled with the requisite quantity of water, and afterwards precipitated with the solution of tin: this precipitate must be frequently edulcorated with water. Exclusive of this, two ounces of fresh cochineal, and one of crystals of tartar, are to be boiled with a sufficient quantity of water, poured off clear, and precipitated with the solution of tin, and the precipitate washed. At the same time two pounds of alum are also to be dissolved in water, precipitated with a lixivium of potash, and the white earth repeatedly washed with boiling water. Finally, both precipitates are to be mixed together in their liquid state, put upon a filter and dried. A cheaper kind of crimson lake is prepared,—Brazil-wood may be employed instead of cochineal, and treated in the foregoing manner.

Several modes of preparing fine red lakes from the madder of different countries were communicated to the Society of Arts by Sir H. C. Englefield, to whom the Society awarded a gold medal for the same. The following is his process of preparing it from the Dutch crop-madder:—Two ounces troy of the finest quality is to be inclosed in a bag of fine and strong calico, large enough to hold three or four times as much; put it into a large marble or porcelain mortar, and pour on it a pint of clear soft water, cold; press the bag in every direction, and pound and rub it about with a pestle, as much as can be done without tearing it, and when the water is loaded with colour, pour it off. Repeat this process by adding fresh water till all the colour is extracted. Heat all the liquor in an earthen or tinned copper vessel, or what is better, a silver vessel, until it just boils; then pour it into a large earthen vessel, and add to it one ounce troy of alum, dissolved in a pint of boiling soft water, which must be thoroughly mixed. Pour in about an ounce and a half of a saturated solution of sub-carbonate of potash; a precipitation will ensue; let it stand till cold, when the supernatant clear, yellow liquor may be poured off from the red precipitate. A quart of boiling water should again be poured on it and well stirred. When cool, the colour may be separated from it by filtration through paper in the usual way; and boiling water should be poured on it in the filter till it passes through of a light straw colour, and free from an alkaline taste. The colour may now be gently dried, and when quite dry it will be found to weigh half an ounce; just a fourth part of the weight of the madder employed. If less alum be employed, the colour will be somewhat deeper: with less than three-fourths of an ounce, the whole of the colouring matter will not unite with the alumina. One ounce of alum to two ounces of madder is the best proportion. Spanish madder affords a colour of rather a deeper tint than the Dutch madder, but does not appear of so pure a red as the Zealand crop-madder. The lake produced from the foregoing process from Smyrna madder is remarkable for the richness and depth of its tint: the colour may be obtained from the fresh roots of madder, and will prove of equal if not superior quality to the dry. Upon the whole, the author of these processes considers the essential advantage of them to

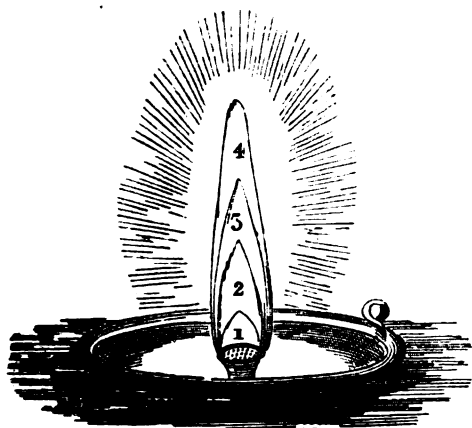


consist in the trituration or pressing of the root in *cold water*. Almost all vegetable colouring matters may be precipitated into lakes, more or less beautiful, by means of alum or oxide of tin.

**LAMP.** A vessel in which fluid combustibles are burned for the purpose of affording artificial light. This is effected by means of a wick or burner (commonly composed of a few threads of linen or cotton), which is immersed in the fluid, and its upper extremity lighted; the fluid then rising gradually by capillary attraction to the lighted end becomes decomposed, and its constituent parts form various gaseous compounds, most of which are inflammable, and these take fire and burn with a degree of brilliancy varying with the nature of the fluid from which they are obtained. The wick being now surrounded by the flame of the burning gases is maintained at a heat sufficient to decompose fresh portions of the combustible matter as they continue to rise to it. The office of the wick, therefore, is merely to decompose the oil or other fluid, and not to afford light by the burning of its own substance; for although the wick or burner is generally composed of some combustible material, yet provided that it be kept plentifully supplied with oil it is consumed so slowly as to afford no perceptible increase of light; and frequently wicks composed of incombustible substances are employed, as asbestos, metallic wire, glass, &c.; and some years back Messrs. S. and D. Gordon obtained a patent for lamps with incombustible wicks, formed of the above-named substances, by drawing the material into fine threads, which are afterwards formed into small bundles and bound round spirally with wire, or rolled up in a piece of fine wire gauze, forming a cylindrical bandage or covering to each bundle. The wicks thus formed contain a vast number of minute interstices, arranged longitudinally in parallel lines, and being placed in an inflammable volatile liquid (as naphtha or alcohol), the liquid is conveyed by capillary attraction to the upper part of the wick for ignition. The composition to be burned in these lamps constitutes another branch of the improvements mentioned in the patent, and consists of a mixture of one part of essential oil with five or six of alcohol or naphtha (which latter is much more economical.) By this admixture a much more brilliant light is obtained than when alcohol alone is used, whilst the smoke and deposit of carbonaceous matter upon the wick which attends the combustion of essential oils by themselves is avoided. These lamps have been made up into a great variety of elegant designs, both modern and antique; they have also been fitted into frames and stands to be placed under tea-urns, coffee-biggins, and tea-kettles, and are extremely convenient in numerous situations, whilst the expense is inconsiderable. They have a circular ring at top for receiving the kettle or other culinary vessel, with the lamp in the centre, lying in a frame, which may be taken out at pleasure as a distinct apparatus to afford light instead of heat. The wicks being incombustible, no snuffing or attention to them is requisite during the time of ignition; all that is necessary is to keep them free from dust when not in use, by screwing on a cap over each wick tube, and to put the plug in the central air-hole to prevent evaporation.

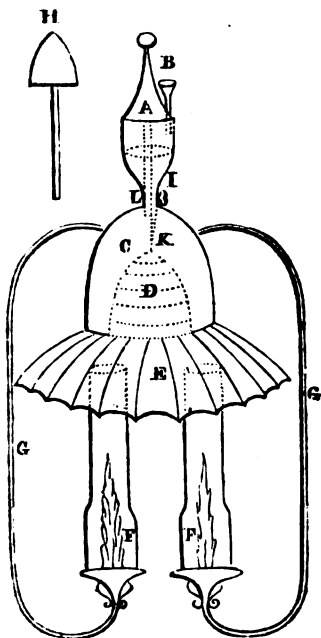
Mr. Blackadder, of Edinburgh, has also paid attention to the subject of lamps with incombustible wicks, and has given in the *Edinburgh Philosophical Journal* a description of several lamps of this description which he had contrived, some of which were well adapted for the combustion of essential oils, spirits of turpentine, &c. The burners he employed consisted of short pieces of bugle heads; some of these he inserted in pieces of talc, and found them to form a very convenient floating light when placed upon the surface of a portion of oil in a glass vessel. Mr. Blackadder's account of these lamps having called the attention of manufacturers to the subject, gave rise to the floating lights now in such general use as night lights, consisting of a short piece of capillary glass tube of very small diameter inserted in the bottom of a thin metallic dish or cup, and placed in a glass vessel containing oil. The cut in the following page represents an improved lamp of this description, which has this peculiar advantage over the ordinary ones, that it is capable of yielding four distinct degrees of flame, so that it may be accommodated to the occasion; a larger

or a smaller one being used according as convenient. This effect is produced by means of two small weights in the form of rings, fitted to lie in a recess at the bottom of the floating dish; by the addition or removal of these weights the immersion of the dish is regulated so as to cause a greater or less flow of

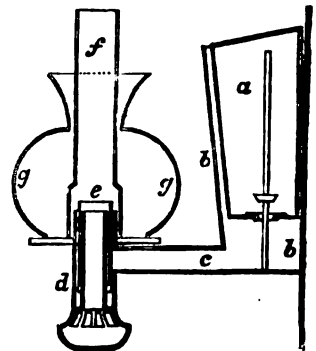


oil through the tube, and consequently to produce a larger or smaller flame; when both weights are removed, the lowest degree of flame, marked 1 in the drawing, is produced; with the smallest ring the flame 2 will be obtained; with the largest, the flame 3; and with the two rings together, the flame will be equal to that marked 4.

We extract from the *Edinburgh Philosophical Journal*, the following description of a "self-generating gas lamp," a title which is equally applicable to every other kind of lamp, since all generate the gas from which the light is obtained; the difference is, that in this lamp the oil is decomposed and converted into gas by falling on a substance previously heated, and the gas is ignited as it issues from the orifice of a tube situated beneath the decomposing chamber, the heat of which is maintained by the flame of the gas; whereas, in the ordinary lamps, the oil is decomposed and ignited at the same point, viz. at the wick. "The oil vessel of this lamp is represented at A., B is the tube by which the oil is admitted; C is the generator; D is a hollow vessel, where the heat from the burners F, underneath, is collected; the dotted lines are projecting ridges on it within the generator, to prevent the oil running down and collecting at the bottom of the generator. E is a circular piece of iron to collect and retain the heat; G are tubes to conduct the gas from C to F; L is a tube to supply the vacancy in it with gas, as the oil is discharged into C; H is a metal heater to fit into D. To use the lamp, fill A partially with oil, alcohol, or any fluid from which gas is produced, and having made the metal heater H red hot, place it in the bulb D; after it has

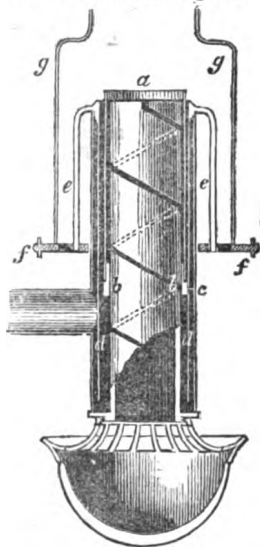


continued in it a minute or two, turn the stop-cock I, allowing the fluid to drop slowly on the heated bulb D below. by which it will be converted into gas. When it is found to escape in sufficient quantities from the burners at F, set it on fire, remove the heater, and a beautiful bright flame will be supported by its own heat as long as there is oil in A; it may be found necessary to replace the first heater by a second, when the lamp is used for the first time, to expel more effectually the atmospheric air from the generator and tubes. The principle of this lamp is the same as that of Mr. Blackadder's (from which probably the idea was taken), viz. to decompose the oil by causing it to pass over an incombustible substance heated to redness; but the arrangements are more complex and not so efficient. Besides the objection to the detached heater, from the trouble of heating so large a mass, in comparison with the incombustible wicks in Mr. Blackadder's plan, the decomposing vessel being of metal, will be found far inferior in effect to glass tubes or similar substances of inferior conducting power, and in a short time would soon become incapable of decomposing the oil, as it is found necessary at the Oil Gas Works to introduce into the retorts pieces of broken bricks, coke, &c., or plates of iron, which are renewed daily. The decomposing chamber D, and the circular rim E, both of which require to be situated over the flame of the lamp, are also highly objectionable, not only as cumbrous and unsightly appendages, but on account of the dark and extensive shadow which they would throw upon the ceiling. The size of wick must be proportioned to the degree of light the lamp is required to afford, but with the ordinary wicks, composed of cotton yarn slightly twisted, if the diameter be much increased, sufficient air does not arrive at the central part of the flame to cause the entire combustion of the fuel, and the lamp consequently burns with much smoke, and a deposit of carbonaceous matter upon the wick takes place; it is therefore found preferable to use two or more small wicks instead of one larger one. Count Rumford, whose experiments upon warming and lighting have produced such great improvements in these two branches of domestic economy, invented a lamp, the wick of which is formed of a kind of broad tape wove for the purpose; and, as a reading lamp, it is equal to any, whilst at the same time its construction is extremely simple: but the greatest improvement yet made in lamps, is the Argand lamp, so named from their inventor, M. Argand, of Geneva. The distinguishing feature of these lamps is that the wick is hollow or tubular, and the wick-holder is so constructed as to allow a passage for the air through the centre of the flame, as well as on the exterior, by which means every particle of the oil is decomposed and burned, and a most brilliant flame is produced, free from smoke or smell. When oil of the best quality is used, lamps of this description are found infinitely superior to all others for all situations where they do not require to be moved about, and are now manufactured in an endless variety of the most tasteful and elegant forms, and with various additional contrivances for regulating the height of the flame, the flow of oil, doing away with shadow of the oil vessel, &c. The annexed cut represents a very common and simple description of Argand lamp, adapted either to stand upon a bracket, or hang against a wall. In these lamps the oil surrounding the wick is maintained constantly at the same level, by a contrivance similar in principle to the bird fountain. *a* is the oil reservoir or fountain, closed at the top, but having an aperture at bottom fitted with a conical or button valve. The reservoir fits loosely into an outer case *b*, so as to allow free admission for the air between the two; *c* is the neck by which the oil flows into the wick-holder *d*, which is composed of two concentric tubes joined together at the bottom by a circular plate, having an aperture in its centre for



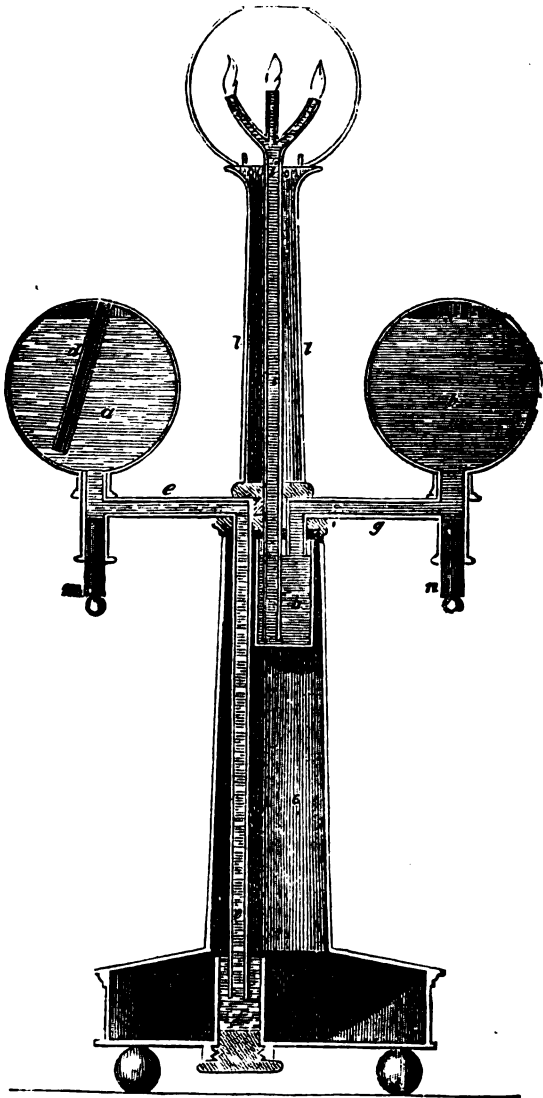
the passage of the air to the centre of the flame, equal to the aperture of the interior tube; *e* is the circular wick, fixed upon a ring, which can be raised or lowered at pleasure, by a contrivance which will require a separate diagram for its illustration. *f* is a glass chimney, to cause a more rapid current of air, and *g* is a ground glass shade, to equalize the light and soften the glare. To charge the lamp, the vessel *a* is withdrawn from the casing *b*, and, being inverted, the valve falls inwards, leaving the aperture open by which the oil is to be introduced. When the reservoir is filled, the aperture is closed by pulling up the wire, or tail, projecting from the valve, and the reservoir may be returned to its erect position without any escape of oil. Upon replacing it within the casing *b*, before it quite reaches the shoulder of the case by which it is supported, the tail of the valve rests upon the bottom of the case, and the valve is pushed inwards, upon which the oil flows from the reservoir into the casing and wick-holder, until it touches the bottom of the reservoir, which descends a little below the level of the wick-holder, when the admission of the air into the reservoir being prevented by the oil in the casing *b*, covering the aperture, no more oil can escape. Upon lighting the lamp, as the oil rises to the wick by its capillary attraction, the level falls in the casing *b*, and the aperture in the vessel *a* becoming uncovered, the air enters and expels a fresh portion of oil, until the level of the oil rises in the case and closes the aperture; and thus, during the time the lamp continues lighted, the oil in the casing and wick-holder is constantly maintained at the same level: a small cup *h* is screwed on below the wick-holder to receive any oil which may chance to overflow; care being taken that the cup shall be so far below the circular aperture of the wick-holder as not to impede the passage of the air to the flame. We shall now proceed to describe the means by which the wick is raised or lowered in order to regulate the flame.

The adjoining figure represents a section of the wick-holder, except that part of the internal tube is shown entire in order to exhibit more clearly a spiral groove which makes two or three turns round it. *a* is the wick, the lower end of which is drawn over a small metal ring *b*, which has a small stud *c*, projecting each way, the internal end entering the spiral groove on the surface of the centre tube, and the external end passing through a longitudinal slit or groove, extending the whole length of a tube *d*, which is soldered into a ring, or collar, resting upon the top of the external tube of the wick-holder; from this ring, or collar, proceed the bent wires *e e*, which support the rim *f*, upon which the chimney *g* rests. Now, upon considering the figure, it will be seen that on turning the rim *f*, the tube *d*, which is connected with it by the bent wires *e e*, will also be turned round, and will carry with it the ring *b*, by its stud *c*; and as one end of the stud is engaged in the spiral groove, it will, in turning round, either ascend or descend along the groove, according to the direction in which it is turned: *h* is the tube by which the oil flows to the wick, and *k* is the



cup to receive any overflows. When lamps are required to give light in one direction, as when placed against a wall, or used as reading lamps, the fountain lamps, similar to that just described, are undoubtedly superior to all others, on account of the abundant and uniform supply of oil which they afford to the wick; but when a lamp is required to throw a light all round, as when placed on a table in the centre of a room, the fountain becomes objectionable on account of the shade it throws; in this case the burner is usually mounted upon a column, and is encircled by a hollow ring at a distance of some inches from

it, containing the oil which flows to the burner by two tubes, and in order that the level of the oil may not greatly vary, the ring is made as flat as possible. This ring also supports a ground glass shade, which, besides softening the light, by its peculiar form, so reflects and refracts the rays in every direction as nearly



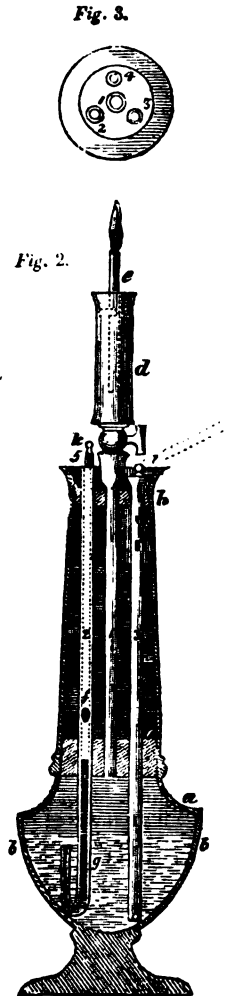
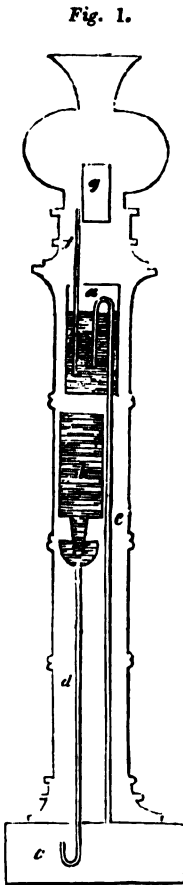
to prevent any shadow being cast by the reservoir; hence these lamps are termed 'sinumbra,' or "shadowless lamps." But although the shadow thrown by such lamps is scarcely perceptible, the light is not equal to that of fountain lamps, owing to the supply of oil being neither so copious nor so uniform as in

the latter; and they are also somewhat cumbrous and awkward to move, owing to the projection of the reservoir and glass shade, and to the centre of gravity of the lamp being carried so high up. To remedy these defects has long been a favourite speculation with many persons, and generally every year one or more patents are taken out for lamps which are supplied with oil from a reservoir situated within the column which supports the burner. Few of these possess any claims to novelty, being most of them founded upon the principle of the Chremnitz fountain, in which a body of water descending through a given height forces a smaller quantity of water, contained in a close vessel, up to nearly an equal height by compressing the air above its surface. As illustrative of the principle we shall describe one or two of these lamps, although as we have already remarked, few of them exhibit much originality of thought. The figure on page 36 represents an arrangement for a lamp described in the *Register of Arts* as the invention of a correspondent in which the resemblance to the Chremnitz fountain will be at once recognised. *a* is a vessel containing water; *b* an oil vessel; *c c* a column and pedestal to support the lamp, closed at the top and bottom, and forming the air vessel; *d* an air tube in *a*, open at top and bottom; *e* a tube soldered into the top of the column *c*, and proceeding from the bottom of *a* to the bottom of cup *f*; *g* a similar tube soldered to *c*, and proceeding from *b*, the lower end descends a little way into the cup *h*; *i* is a glass tube ascending from the bottom of the cup *h*, through a tight joint, and branching at top into three capillary jets, forming the burner, and the tube *l*, which surrounds it, serves to receive any oil that may flow over; *m* and *n* are two plugs in the bottom of *e* and *g*. To use the lamp proceed as follows:—invert the lamp, withdraw the plugs *m* and *n*, fill *a* with water, and *b* with oil; then replace the plugs in the position shown in the drawing, and place the lamp on its base. The oil will now flow from *b* into *h*, until the mouth of the tube *g* is covered; at the same time the water flowing from *a* into *f* will compress the air in *c*, which, acting on the surface of the oil in *h*, will force it up the tube *i* to the burners; by this the oil in *h* will fall below the mouth of *f*, when a portion of the compressed air passes into *b*, displacing an equal bulk of oil; by these means the oil in *h* is always maintained at the same level as the mouth of *g*; the capacity of *a* is not equal to that of the base up to the level of the brim of the cup *f*; but it is clear that by means of the air-tube *d*, the height of the column of water will always be equal to the height of the lower opening of *d*, above the brim of *f*. To extinguish the lamp, push the plugs *m* and *n* into the necks of *e* and *g*, which stops the supply of oil. The cup *f* is screwed into the bottom of *c*, and must be unscrewed to discharge the water in *c*, when the vessel becomes empty.

In the sketch on page 38, *Fig. 1*, represents a section of a lamp invented by Mr. Bright, of Bruton Street, which was exhibited at the National Repository, and which we have seen in use elsewhere, and it appeared to us to afford a strong and steady light. The principle is precisely similar to that of the one just described, but it is much more compact, and the general arrangement is better. This lamp, and the mode of its action, may be briefly described as follows:—The water vessel *b* is an inverted fountain, which empties itself into the air chamber *c*, through the pipe *d*; the air thus displaced is forced up the rising bent tube *e* into the oil vessel *a*, from whence, as it cannot escape, it presses upon the oil and forces it up the pipe *f* to the burner *g*. It will be seen that by this arrangement the two columns of oil and water will be constantly in equilibrio.

The last lamp upon this static principle which we shall notice, differs somewhat from the preceding, and possesses rather more novelty. It is represented in section on p. 38, *Fig. 2*, and the following is an extract from the inventor's description of it in the *Register of Arts*:—*a* a glass vessel forming the body of the lamp; surmounted by a glass column connected with *a* by the cork *c*, which fits tightly into each, and closed at top by the cork *h*. No. 2 a glass tube descending through the two corks *h* and *c*, to the bottom of the vessel *a*, and bent upwards again as far as *g*, it communicates with the column by the hole *f*, which may be closed by a sliding tube *5*, and the latter be closed by the stopper *k* at its top. No. 1 a glass tube passing through the corks *h* and *c*, its lower end opening

into *a*, and its upper connected by a stop cock with *d*, a glass vessel closed at top and bottom with corks. *e* a capillary tube descending half way down *d*. No. 3 a tube passing through *h* and *c*, and reaching to the bottom of *a*; it has two small openings into the column in its upper part, which may be closed by the stopper *l*. No. 4, (not seen in the section, but shown in Fig. 3, which is a plan of the tubes,) is a tube passing through *h* and *c* into the upper part of *a*. The mode of filling the lamp is as follows: close the hole *f* in No. 2,



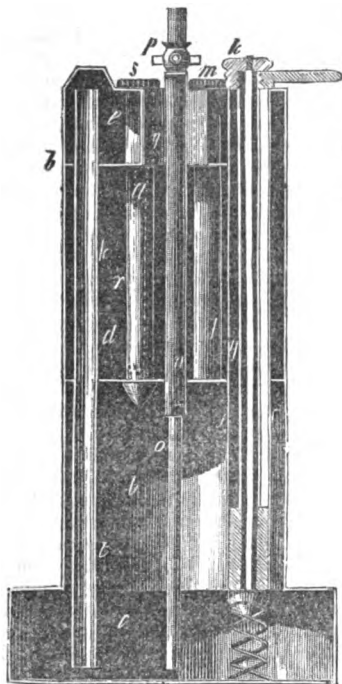
and open 1, 2, and 3, and through 5 pour quicksilver till *a* is filled to the level of the top of the bent leg *g*, then close 5 by its stopper *k*. In the top of 3 insert a bent tube, (shown by the dotted lines,) and suck the air out of the column, when the mercury will rise in 3, pass through the holes in its upper end, and occupy the space shown by the dotted lines. Remove the bent tube, and

insert the stopper *l*, and through 4 pour water into *a*, up to the line *b b*, and oil up to the cock *c*, and close No. 4, and the operation is complete. When the lamp is wanted for use, take the stopper out of No. 5, and raise 5 till the hole *f* becomes open, when the mercury will descend and pass over *g* into the bottom of *a*, forcing the oil up No. 1 to the burner *e*, to which a light being applied, it will continue burning steadily till the oil in *a* and the mercury in *i* are exhausted, when the lamp is to be refilled by exhausting the air in *i*, and pouring oil through No. 4. The flame may be regulated or extinguished by means of the stop-cock. The height of *e* above *g* may be equal to, but must not exceed, that of a column of oil, whose pressure shall be equivalent to the pressure of the column of mercury.

From the foregoing description, it will be seen that the columns of oil and of mercury always maintain their respective heights, and the supply of oil to the burner is consequently always uniform. The inventor states, that the lamp (which was merely got up for an experiment) afforded a steady light upon trial.

In the lamp which is represented in section in the annexed engraving, and which is the invention of R. F. Jenour, the air is compressed in a closed

reservoir, by means of a condensing syringe, and a communication being formed between the air chamber and the oil chamber, the air by its expansion forces the oil up the supply pipe to the burner. The body of the lamp is divided into three compartments by two discs, *a* and *b*; *c* is the oil vessel, *d* a space to receive the overflowings from the burner, and *e* the air vessel; *f* is a condensing syringe, the piston rod of which *g* is hollow; the lower end of the syringe is closed by a valve *h*, pressed against it by springs; a rod from this valve passes through *g*, and can be screwed up by the nut *k*; *l* is a tube connecting the oil vessel *c* with the air vessel *e*, which has another aperture to the atmosphere, closed by the nut *m*; *n* is the tube for supplying the burner, having a capillary tube *o*, cemented into its lower end, which descends to the bottom of the oil vessel; *p* is a stop-cock for cutting off the communication with the burner, which being of the common description is not shown. The middle compartment *d* opens to the atmosphere by a short tube *q*, surrounding *n*; *r* is a tube opening into *c*; it is pierced with numerous holes at the lower end, and is closed by a valve which is

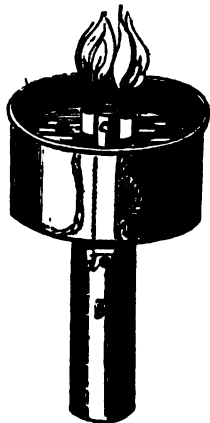


secured by a nut *s* screwing on to the top of a rod attached to the valve; *t* an air pipe descending from the top of *e* to the bottom of *c*; the air, therefore, ascends through the oil in *c*, and collects above its surface and in the air vessel *e*. To charge the lamp with oil unscrew the nut *m*, and slacken the nut *s*, then pour in oil by the tube *q*, and it will descend into *c* through the holes in *r*; the nuts *m* and *s* must then be screwed down again. The nut *k* must now be unscrewed from the rod of the valve *h*, and the air injected by the syringe, taking care to close the orifice of the piston rod, by applying the finger to it at each stroke; when the resistance against the valve increases, till the syringe



can no longer be worked, the nut *k* must be again screwed on, and the lamp is ready for use, by merely opening the stop-cock *p*. There have been many lamps upon the principle of the one just described, but from the difficulty of regulating them, they have not come into general use; this difficulty arises in part from the continually varying pressure of the condensed air, occasioned by its increase of volume as the oil consumes, and also from the difficulty of regulating the supply of oil to the burner, so as neither to overflow nor fall short of what is required. In a lamp invented by Mr. Machell, a piece of cotton is introduced through the bore of a cock, when, by turning the plug, the passage may be regulated with considerable accuracy. In the present lamp, the patentee effects this by a capillary tube, which retards the flow of oil in proportion as it is lengthened, and this is the principal improvement claimed in the patent. The objection to this seems to be that the flow cannot be regulated at pleasure. Upon the whole, although many of the lamps with the oil reservoir contained in the base, exhibit considerable ingenuity in various parts of their details, yet very few have been found to answer in practice, being mostly either troublesome to manage, or unequal in their action; and the only lamp of this description which we have yet seen which seems to be of decided practical utility is one of French invention. In this lamp there are two small pumps worked by a train of clock-work situated beneath the reservoir of oil in the pedestal of the lamp. These pumps, which in their construction resemble a pair of bellows, work with very little friction, and impel the oil in a copious stream to the burner, and no inconvenience can result from an excess in the supply as the overflow merely returns into the reservoir.

We shall now proceed to notice one or two lamps adapted to the burning of concrete oils and solid unctuous substances, as fat, tallow, butter of cacao. For the purpose of illumination these substances are on a par with oil, affording an equally brilliant light and at a much less cost; but in order to burn them in a lamp it is requisite previously to render them fluid, and to maintain them in that state so long as the lamp is in use. Various arrangements are employed for this purpose, but the principle is the same in all; viz. to convey a portion of the heat arising from the flame of the lamp to the combustible matter, by means of some good conductor, as an iron or copper tube or wire inserted in the combustible mass, and coming in contact or nearly so with the flame. A very simple lamp of this description is exhibited in the annexed cut; *a* is the fat rendered fluid, lying in the body of the lamp; (the cover of the lamp being removed to show the interior;) *c* is a small tube to convey air into the middle of the flame (to perfect the combustion, on the principle of the Argand burner); this tube opens at the lower end into the large tube *b*, as shown by dots; a small perforation is also made at *d*, to allow the air to flow freely into the tube *c*, when the lamp is fixed in the socket of a candlestick. On each side of the air tube a short piece of copper pipe is fixed by hard solder, for holding the cotton wicks; these tubes (which ought to be longer) get intensely hot, and, by the conducting power of the metal, the heat is transmitted to the fat, which, melting in consequence, flows up the wick like fine oil, but infinitely preferable, on account of its diffusing no unpleasant smell during the combustion.



The Hon. E. Cochrane obtained a patent for a lamp, named by him the "Patent Dissolvent Lamp," which, like the one just described, is calculated to burn tallow and concrete oils. These lamps, which have been very extensively manufactured in a variety of elegant forms by Mr. José, of Regent-street, afford an extremely brilliant light at a very small cost. The engraving and description in the following page will explain the principle of these lamps. *a a* are two solid bent metal rods that conduct the heat received from the flame of the lamp to

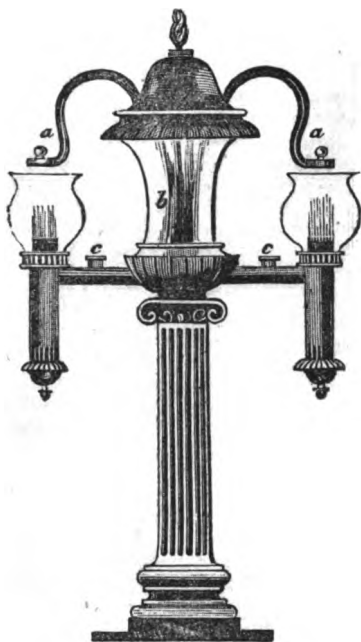
the tallow contained in the reservoir *b*; the ends of these conductors are therefore made to descend to the bottom of the reservoir; *c c* are two apertures (with covers that screw on) made in the supply pipe, for the purpose of pouring in a small quantity of melted tallow upon lighting the lamp, after which the heat from the combustion being conducted into the reservoir, the supply of fluid tallow is uniformly kept up until it is all consumed.

We extract from a printed circular of the manufacturer the following observations on the advantages attending the use of these lamps:—

“To those acquainted with the superior combustible properties of tallow and cocoa-nut oil, it is unnecessary to say more than that these lamps effectually melt and burn both, and that the price of the latter, at the manufactory, is 2s. 6d. per gallon; but to others, to whom their good qualities are less known, it is necessary to state, that from the comparatively small portion of oxygen necessary to complete their combustion, the total absence of smoke and smell is insured, and the brilliancy of the flame is such as no lamp ever before produced, and nothing but the best gas-light can equal. To families who kill their own meat, innkeepers, proprietors of cook-shops, &c. &c. a two-fold advantage will be found in the use of

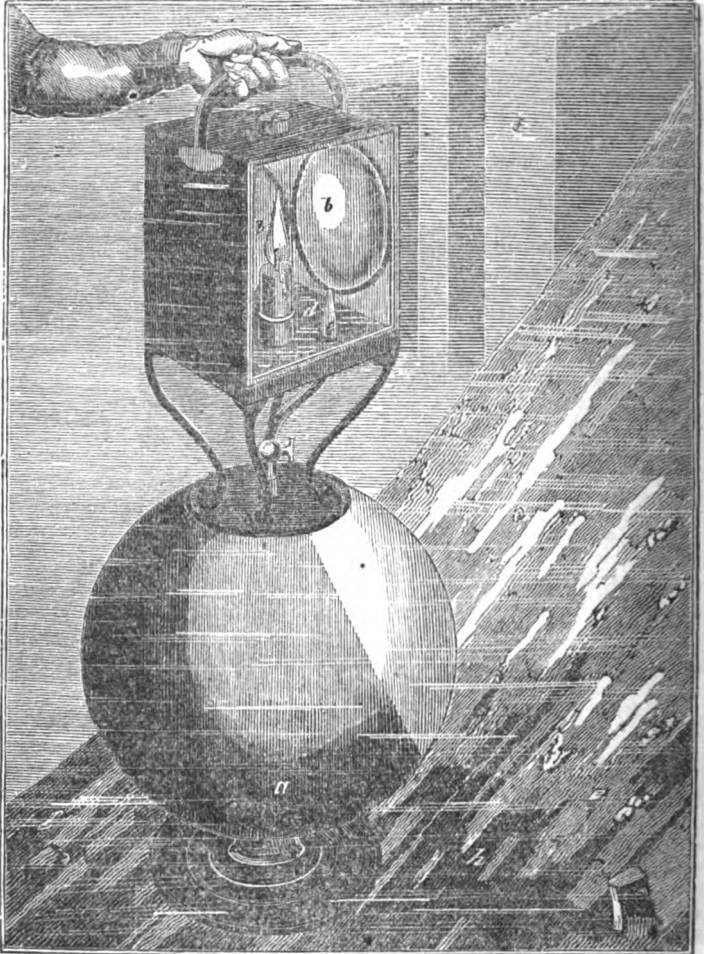
these lamps, as it is not merely tallow that they burn, but grease of every description, such as dripping, pot skimmings, &c. &c., a pound of which, value about 3d., will continue to burn for full twelve hours in a common-sized dissolvent Argand burner, to yield light equal to eight candles, being no more than a farthing an hour.”

The following ingenious plan for a lamp to burn under water appeared in the *Register of Arts*, in connexion with a diving apparatus, for examining the breaches in the Thames Tunnel, and might very often be of service in the diving bell, when the water, as is frequently the case, is so disturbed that sufficient light is not refracted through it at great depths to permit accurate examination. A spherical or cylindrical vessel is to be provided, similar to the vessels containing the portable gas for burning; into this a few atmospheres of pure oxygen are to be condensed by a syringe, through a valve at the bottom: a short jet tube is then to be screwed into the top of the vessel. A lantern, with a strong and powerful reflector, must be attached to the upper part of the vessel containing the condensed oxygen, permitting the jet tube to enter the lantern. The top of the lantern must be provided with a screw cap; a piece of wax candle may be advantageously employed for the light. It is needless to say that the apparatus must be air and water tight. Immediately before use, pour into the lamp a solution of caustic alkali, potash or soda, and screw on the cap; then turn the cock gently to admit a sufficient quantity of oxygen through the jet tube, to support the combustion of the candle. The products of the combustion will be carbonic acid and water; the former will be absorbed by the alkaline solution as it is formed, and the latter will be condensed by the sides of the lantern; the oxygen admitted will unite with the nitrogen of the



air of the lantern (which is not consumed), and will form a supply of ordinary atmospheric air.

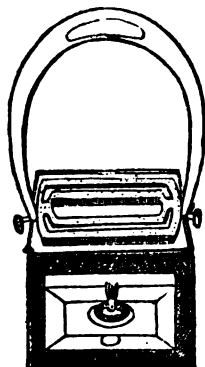
The annexed figure represents a lamp as constructed by the inventor, which, upon trial, was found to answer very well.



*Reference to Engraving.*—*a*, the vessel of condensed gas; *b b*, the reflector, placed at suitable angles to accumulate the light upon a bull's eye magnifier fixed in front, but removed in the drawing to show the interior of the lantern; *c*, the screw cap of the lantern; *d*, the alkaline solution; *e*, the jet pipe; *f*, portions of the shield frames of the tunnel; *h*, accumulation of mud and earth as it may be supposed to have entered the tunnel.

The cut on p. 43, represents one of the many ways in which the "march of

mind" in the present day accelerates the march of the body; the subject is a "stirrup lantern," intended, in the words of Scripture, as a "light unto our feet, and a lamp unto our paths." The stirrup lantern is a small square lantern, fixed at the bottom of a stirrup by means of two screw rings on each side, as exhibited in the drawing, and by unscrewing them, the lantern may be detached from the stirrup when requisite. The lamp part is so contrived that no oil can be spilt, nor the steady light which is thrown across the road before the horse's feet be at all impaired by any motion of the horse. The front part, as shown in the drawing, is of glass, through which is seen the lamp, burner, and wick; behind, there is placed a reflector for transmitting the light to the front. It is supplied with a constant current of air, by means of apertures, in a sort of double casing, which is so disposed as to prevent any gust of wind from extinguishing the light.



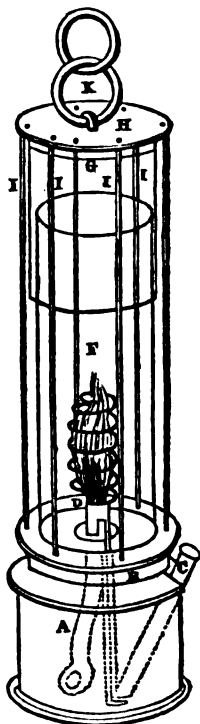
Amongst the numerous contrivances for rendering lamps ornamental, is a very singular one, which we must briefly notice: it consists in surrounding the light by screens of ground glass, on which are painted various elegant devices; these screens are suspended upon a fine pivot, in the same way as a common chimney cowl, and have fixed across their upper orifice a number of oblique vanes or fans; and the current of heated air from the lamp, impinging upon these vanes, imparts to the screens a slow rotatory motion. The pleasing effect of crystal chandelier ornaments in refracting the rays of light is well known; but the chandelier makers have hitherto principally devoted their attention to increasing the number of reflecting and refracting surfaces without paying much regard to their form, magnitude, or position with respect to each other. M. Osler, of Birmingham, however, has lately introduced a great improvement in this branch of the subject; instead of a great number of detached crystal drops, he forms a complete casing for the light by ranging a number of square or triangular prisms in a cylindrical or conical figure, the sides of the prisms touching each other, and their ends being connected by various ingenious means, for which he has a patent. The effect thus produced by the large surface of the prisms is exceedingly brilliant and splendid.

We shall conclude this article by a description of that admirable invention of Sir H. Davy, the "safety lamp," by the aid of which the hazardous occupations of the miner are now carried on with considerably less difficulty, and with infinitely less danger, than before this invention. The gases extricated in mines (which are destructive to animal life) are of two kinds, and are by the miners called the *choak damp*, and the *fire damp*; the former consists for the most part of carbonic acid gas, hovers about the lower parts of the mine, and extinguishes their lights; and the latter, which is simply hydrogen gas, occupies the superior spaces, and involves incalculable mischief, from the combustion produced by its contact with the flame of the miners' candles. The consequences resulting from the frequent explosion of this inflammable air, have been lamentable and tremendous in the highest degree; and whilst a source of the greatest terror to the persons most intimately affected by its operations, it has excited the deepest sympathy and commiseration in the general mind. To remove an evil so dreadful in its nature, Sir H. Davy applied his energetic and comprehensive mind to the discovery of some means by which these saddening calamities might be averted, and after numerous experiments, devised the safety lamp, an invention that must ever rank him high among the benefactors of mankind.

To afford a clear idea of the nature of the lamp, we shall avail ourselves of the language of Dr. Ure, who has treated it, and the points relatively consequent upon it, in a very masterly manner. "In the parts of coal mines where danger was apprehended from fire-damp, miners had been accustomed to guide themselves,

or to work, by the light afforded by the sparks of steel struck off from a wheel of flint. But even this apparatus, though much less dangerous than a candle, sometimes produced explosions of the fire-damp. A perfect security from accident is, however, offered to the miner, in the use of a safe lamp, which transmits its light, and is fed with air, through a cylinder of iron or copper wire gauze; and this fine invention has the advantage of requiring no machinery, no philosophical knowledge to direct its use, and is made at a very cheap rate. The apertures in the gauze should not be more than 1-20th of an inch square. As the fire-damp is not inflamed by ignited wire, the thickness of the wire is not of importance, but wire from 1-40th to 1-50th of an inch in diameter is most convenient. The cage or cylinder should be made by double joinings, the gauze being folded over in such a manner as to leave no apertures. When it is cylindrical, it should not be more than two inches in diameter; for in larger cylinders, the combustion of the fire-damp renders the top inconveniently hot; and a double top is always a proper precaution, fixed one-half or three-fourths of an inch above the first top. The gauze cylinders should be fastened to the lamp by a screw of four or five turns, and fitted to the screw by a tight ring. All joinings in the lamp should be made with hard solder; and the security depends upon the circumstance, that no aperture exists in the apparatus larger than in the wire gauze." The parts of the lamp are—

A, the brass cistern which contains the oil, pierced near the centre with a vertical narrow tube, nearly filled with a wire which is recurved above, in the level of the burner, to trim the wick, by acting on the lower end of the wire, with the fingers: it is called the safety trimmer. B, the rim in which the wire gauze cover is fixed, and which is fastened to the cistern by a movable screw. C, an aperture for supplying oil, fitted with a screw or cork, and which communicates with the bottom of the cistern by a tube; and a central aperture for the wick. D, the burner, or receptacle for the wick, over which is fixed the coil of platinum wire. F, the wire gauze cylinder, which should not have less than 625 apertures to the square inch. G, the second top, three-fourths of an inch above the first, surmounted by a brass or copper plate, to which the rings of suspension are fixed. I, I, I, six thick vertical wires, joining the cistern below to the top plate, and serving as protecting and strengthening pillars round the cage. When the wire-gauze safe lamp is lighted and introduced into an atmosphere gradually mixed with fire-damp, the first effect of the fire-damp is to increase the length and size of the flame. When the inflammable gas forms as much as 1-12th of the volume of the air, the cylinder becomes filled with a feeble blue flame, but the flame of the wick appears burning brightly within the blue flame, and the light of the lamp augments, till the fire-damp increases to one-eighth or one-fourth, when it is lost in the flame of the fire-damp; which in this case fills the cylinder with a pretty strong light. As long as any explosive mixture of gas exists in contact with the lamp, so long it will give light; and when it is extinguished, which happens when the foul air constitutes as much as one-third of the volume of the atmosphere, the air is no longer proper for respiration; for though animal life will continue where flame is extinguished, yet it is always with suffering. By fixing a coil of platinum wire above the wick, ignition will continue in the metal when the lamp is itself extinguished; and from the ignited wire, the wick may be again rekindled in going into a less inflammable atmosphere. In a letter to the Royal Society, dated Newcastle-upon-Tyne, Sir H. Davy says, "All the lamps



that I have examined, have at different times been red-hot, and a workman at the Hepburn Colliery showed me a lamp, which, though it had been in use about sixteen hours a-day for nearly three months, was still in excellent condition; he also said it had been red-hot, sometimes for several hours together. Wherever workmen, however, are exposed to such highly explosive mixtures, double gauze lamps should be used; or a lamp in which the circulation of the air is diminished by a tin plate reflector, placed in the inside; or a cylinder of glass, reaching as high as the double wire, with an aperture in the inside; or slips of Muscovy glass may be placed within this lamp; and in this way the quantity of fire-damp consumed, and consequently of heat produced, may be diminished to any extent. Such lamps, likewise, may be more easily cleaned than the simple wire gauze lamps; for the smoke may be wiped off in an instant from the tin plate or glass. If a blower or strong current of fire-damp is to be approached, double gauze lamps, or lamps in which the circulation of the air is interrupted by slips of metal or glass should be used, or if the single lamp be employed, it should be put into a common horn or glass lantern, the door of which may be removed or open."

Notwithstanding the increased security afforded by the safety lamp, coal miners are slow to avail themselves of it, owing to the inferior degree of light it affords compared with that given by a naked candle. This arises from two causes, viz. the necessary obstruction offered by the black wire, of which the cage, or gauze is composed, within which the lamp is placed; and the casual obstruction occasioned by the adhesion of smoke to the inside of the cage, when the lamp is not carefully trimmed, and of smut and dust to the outside of the cage.

To obviate these objections, Mr. Roberts, of St. Helen's, Lancashire, has introduced some modifications and improvements in the construction of the safety lamp, for which he has received a reward from the Society of Arts. To diminish the obscuration occasioned by the first cause, Mr. Roberts proposes that the wire shall be kept bright and polished, by cleaning the cage every night with a soft brush, and the black powder, or smut, which occurs in all coal mines, especially in the neighbourhood of faults; this smut is pulverulent non-bitumenous coal, sufficiently hard to remove the rust from the surface of the wire, without materially wearing the wire itself. As the lamp is at present constructed, the oil will run out of the cup or receptacle in which (it is placed, if the lamp is laid in a horizontal position, an accident which frequently occurs on account of the lamp being rather top heavy. When this happens, the gauze becomes smeared over with viscid oil, which causes the coal dust floating in the air of the mine to adhere to it, and in a short time to fill up, more or less, the meshes of the gauze. By merely shaking or tapping the lamp, the dust will not be disengaged; and if the miner attempts to clear his lamp by blowing through the wire gauze, he runs the risk of putting out the light, and, after all, very imperfectly clears the meshes; there is also, perhaps, some risk of forcing the flame through

Fig. 1.

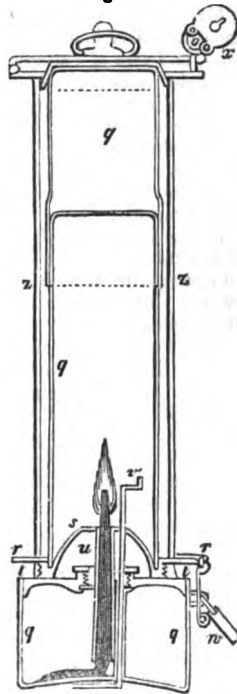
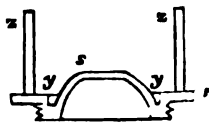


Fig. 2.



the meshes on the opposite side, and of producing an explosion, if the surrounding air is inflammable. In Mr. Roberts's lamp the overflow of the oil is impossible, on account of the dome-shaped cover which surrounds the wick; the dust, therefore, that settles on the gauze may be dislodged by a mere tap of the finger, or what would perhaps be better, by the application of a small brush similar to that which soldiers carry to clear the pan of their muskets, and which might be attached by a bit of small chain to the handle of the lamp. *Fig. 1*, on the preceding page, represents a section of the lamp *p p*, and wire gauze *q q*; *r r*, a screwed cap, with a hollow dome *s*; it screws into the neck, *t t*, of the lamp; the dome rises a little above the neck holder *u*, having an opening at top to let the wick and trimming wire *v*, rise through. This dome serves to catch and retain any oil that may be spilt by shaking the lamp, or knocking it over, thereby protecting the wire gauze *q* from being smeared: *w* and *x*, two locks, the former to secure the cap *q*, and the latter to secure the wire gauze *q* from being removed. *Fig. 2*, a section of the cap and dome, *r r s*, separate from the lamp; the wire gauze fits into the cavity *y y*, around the dome *s*; *z z*, two of the four wires which serve to hold the wire gauze.

Mr. Bonner, of Monkwearmouth, Durham, has a patent for an improvement upon the safety lamp, which consists in a means of increasing the light of the lamp, and also of extinguishing it instantaneously. The mode of increasing the light is as follows:—Instead of introducing a wick in the centre of the lamp, as is usually practised, he introduces a series of small wicks round a centre tube, and by lighting one, two, or more wicks at a time, little or much light is obtained. The means of instantly extinguishing the light consists in a metal cap, or extinguisher, suspended within the wire gauze tube by a pin or catch; upon withdrawing the pin the extinguisher falls over the wick and the light is put out.

In Mr. Murray's safety lamp the wire gauze tube is suspended by two concentric tubes of strong glass, the space between the two tubes being nearly filled with water; by this means a much greater degree of light is obtained, but we are not sure that the risk is not also greater than when a wire gauze tube is employed.

**LAMP-BLACK.** See **BLACK**.

**LANCET.** A two-edged and pointed surgical instrument, chiefly used for opening veins in the operation of bleeding.

**LANTERN.** A transparent case to contain a light. Lanterns are of various kinds adapted to their peculiar uses; most of them are, however, too well known to need a description here. The dark lantern is so called from the circumstance of the light being entirely screened from observation at pleasure, by means of a door or sliding shutter, that covers its only aperture for the transmission of light. See **LAMP**.

*Lantern, Magic*, is an amusing optical machine, whereby painted objects upon glass placed between lenses, become considerably magnified in their shadows, which are projected against a whitened wall or screen. The lantern is inclosed so that no light can pass out of it, except through a double convex or plano-convex lens; around the circumference of this lens is fixed one end of a tube that projects from the lantern; the fine end of this tube receives another smaller tube which slides in it, and carries at its remote extremity a double convex lens. On the fixed tube between the two lenses, lateral apertures, or vertical slits are made, through which the objects painted on slips of glass are slid. The objects are thus illuminated, and their form and colours, on a magnified scale, transmitted with the light upon the screen.

The optical delusion termed *Phantasmagoria*, is produced by a similar machine to the magic-lantern; but instead of the figures being painted on transparent glass, all the glass is rendered opaque except the figure, which is painted in transparent colours, the light therefore shines only through the figure, which is thrown upon a very thin screen of silk placed between the spectators and the lantern; and it is by moving the instrument backwards or forwards, that the figures appear to recede or approach.

**LAPIDIFICATION.** The art of cutting and polishing stones as practised

by lapidaries. The stone to be cut is cemented to the end of a stick, and the different facets or planes on its surfaces are formed by a little simple mill contrived for the purpose. In India the mill is made of a mixture of lac resin and emery (or corundum) by melting one part of the former, and then mixing two of the latter with it by degrees; and, subsequently, well beating and rolling the paste to give it solidity, and the required form. In this country, the soft metals, such as fine copper, or the alloys of tin and lead, are used as the substance for the mill or grinding-wheel; in the surface of which is impressed diamond dust, emery powder, or other suitable abrading or polishing powders. The mill is made to revolve horizontally. Near to the mill is fixed a thick upright peg of wood, called a guage, which is pierced with small holes in all directions, and the process of forming the facets thus takes place. The stone at one end of the stick is applied to the surface of the mill, and the opposite end of the stick is inserted into one of the holes of the guage; in this position it is kept steady by the workman with his right hand, whilst he gives motion to the mill by his left. The skill of the lapidary is exercised in regulating the velocity of the mill, and on the pressure of the stone against it, with an almost imperceptible tendency to one or other direction in different stages of the work, examining each facet at very short intervals, in order to giving as great precision as possible to its size and form. The cutting being completed, the polishing is effected by changing the mill-wheel for another usually made of brass, the surface of which is charged with fine emery, tripoli or rotten-stone, by the successive use of which the facets are perfected and brightened.

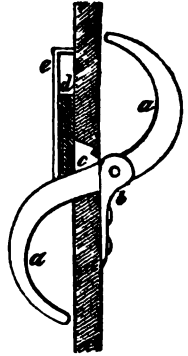
LATCH. A simple fastening to doors. The original and simplest form of a latch, is the little falling bar hooked, and the catch; the former being fixed on the door, and dropping into a notch of the latter, which is fixed to the door-post. On the opposite side of the door such latches were formerly lifted by a string passing through the door, or by a finger inserted through a hole under the latch. In process of time a little lever was made to perform this office, and next to the lever was added a bowed handle. This very useful combination now goes by the name of a *thumb latch*, and such are our facilities of manufacture, that millions of these are made annually in the neighbourhood of Birmingham, and rendered to the dealers at prices averaging not more than three half-pence each. The work people, are, however, very inadequately remunerated for their valuable labour. Thumb latches of a more massive and finished description, with round black varnished handles, are distinguished from the former by the term of *Norfolk latches*. For the inner doors of houses a variety of spring latches are extensively used termed *bow latches*, (which are those on square plates with brass knob or ring handles,) and *long latches* (chiefly distinguished from the other by the length and form of their plates). Some of these are made without handles, and keys are employed to open them externally; but wherever elegance or neatness is studied, *mortise latches* are used; these are let into the thickness of the door in the manner of mortise locks, and nothing is visible on either side of the door but an ornamental handle; the folding windows called French sashes are usually provided with them. There is another kind of latch which affords all the security of a lock, with numerous wards, termed the *French latch*. A small, but broad, flat key, having numerous wards cut out of a solid plate of metal, is passed through a narrow horizontal perforation in the door (covered with a suitable escutcheon), whence it enters the body of the latch; the key being then merely lifted upwards, the solid wards of the latch pass through the interstices of the key, permitting the latter thus to unlatch the door.

A very simple and convenient common latch, well adapted to stable doors, was recently invented by Mr. T. N. Parker, of Sweeny, which we will take leave to call the *pull latch*, as it may be opened on either side of the door by a pull. It is represented in the cut on the following page; *a a* is a curved piece of iron like the letter *S*, which turns upon a joint at *b*, and passes through a hole in the door at *c*, and supports the latch *d*, which is inclosed by the usual keeper *e*. On one side of the door the curved hook *a* acts as a lever of the first class



in lifting the latch; while in the other the curved hook *a* acts as a lever of the second class for the same purpose. The common lever is thus converted into two handles besides performing its own office.

**LATHS** are long, thin, and narrow slips of wood nailed to the rafters of a roof to sustain the covering, or to the joists of a room, in order to support or hold up the plastered ceiling; they are also used for light fencing and various other purposes. Laths are usually made by rending them out of fir or oak; they are made of various lengths, from 2 feet to 4 feet, and are distinguished by three different thicknesses, termed single, lath and half, and double; the latter signifying double the thickness of the single, and lath and a half the medium thickness. In the United States of America, where manual labour is at present more scarce than in this country, machinery has been employed for rending as well as for sawing out laths: there is nothing original in the latter operation, but there is apparently something worthy of notice by our countrymen in the annexed reports of American patents, which we extract from the *Franklin Journal* of Philadelphia.



In Rice's machine, "a stock is fixed in a frame, in which it slides freely backward and forward; it is moved by a cog-wheel, which works in cogs on one side of the stock in the manner of a rack and pinion. A knife is fixed upon the stock, and the timber to be cut into laths, &c. is fixed in a frame, and is made to bear against the stock, and the lath is cut by the traversing motion of the stock. The knife, it is said, may have a double edge, so as to cut a lath both by the forward and backward motion."

Lynch's machine "consists of a long plank, which operates as a plane stock; this plank is made to slide upon its edge between upright standards upon a firm platform; a wide iron, like a plane-iron, is fixed so as to cut on one face of this plank much in the manner of the cutters of some shingle machines; the throat of the plane, if we may so call it, has other cutters standing at right angles with the first cutter, and at such distances apart as to reduce the laths to a proper width. The cutter plank is made to traverse by means of a pitman at one end, operated upon by any suitable power."

**LATHE.** A machine chiefly used for giving a truly circular form to wood, metals, and other substances. See **TURNING.**

**LEAD.** A metal of a bluish-white colour, and when recently cut, of considerable lustre. It is very soft and flexible; not very tenacious, and consequently incapable of being drawn into very fine wire; yet its malleability permits it to be extended, either under the hammer or the rollers, into very thin sheets. Its specific gravity is 11.35; it soils paper and the fingers by friction, imparting a slight taste and a peculiar smell: it is a good conductor of heat; melts at 612° Fahr., and when cooled slowly, crystallizes into quadrangular pyramids. Lead is brittle at the time of congelation, and may then be broken to pieces with a hammer. Although the brightness of fresh cut or scraped lead soon goes off, it does not alter much by exposure to the air; owing, it is supposed, to a thin film of oxide being formed upon its surface, which defends the metal from further corrosion; this property renders it peculiarly suitable for the gutters and coverings of buildings. Lead ore is found in most parts of the world. In Britain, the principal lead mines are situated in Cornwall, Devonshire; in Northumberland, Westmoreland, Cumberland, Derbyshire, Durham, Lancashire, and Shropshire; in Flintshire, and various parts of Wales; also in several districts of Scotland. The smelting is performed either in a blast furnace, called an "ore hearth," or in a reverberatory furnace. In the former method the ore and fuel are mixed together and exposed to the action of the blast, which quickly fuses the metal and causes it to fall into the lower part of the hearth, where it is protected from the oxygen of the blast by the scoriae that floats upon its surface. When the fluid lead is tapped, a sufficient

quantity of it is left in the furnace to float the liquid scoriæ; but when the whole of the lead is to be drawn off, the blast is stopped, and some lime is thrown into the furnace to concrete the scoriæ whilst the lead is run out. In smelting by the reverberatory, which is undoubtedly the best, the fire is made at one end, and the flame passes over the hearth and enters into an oblique chimney, which terminates in a perpendicular one, called a stock, of considerable height. The length of the hearth, from the place where the fire enters to the chimney, is about 11 feet, 2 feet of which constitute the throat of the furnace; the remainder forms a concave surface,  $4\frac{1}{2}$  feet wide at the throat of the furnace, and rather more than 7 feet at the distance of 2 feet from the throat, about 7 feet in the middle of the hearth, and 6 feet at 2 feet distance from the chimney, and nearly 3 feet where the flame enters the chimney, which it does through two apertures, each 10 inches square. The throat of the furnace is 2 feet long, 4 feet wide, and 6 inches deep. The length of the fire-place is 4 feet, equal to the width of the throat; its width is 2 feet, and depth 3 feet from the grate to the throat of the furnace; the section of the oblique chimney is 16 inches square, and of the perpendicular 20 inches, supposing a straight horizontal line drawn from the lower plane of the throat of the chimney to the opposite side of the furnace; the lower part of the concave hearth, which is in the middle of this cavity, is 19 inches below this line, the roof of the furnace being 17 inches above the same line; the rest of the hearth is conformably concave. The furnace on one side has three openings, about 10 inches square, at equal distances from each other, and provided with iron doors, which can be removed as occasion may require. Besides these apertures, which are for the purpose of raking and stirring the ore, &c., and consequently upon a level with the horizontal line before alluded to, there are two others of smaller dimensions, one of them for the discharge of the fluid metal, and the other for the scoriæ. The ore is introduced at the roof of the furnace through a hollow shaped vessel.

The ores of lead, like those of most other metals, are combined with various kinds of earthy matter, which require them to be pulverized before they undergo the smelting process. The pounding is sometimes performed by hammers, but usually by a stamping mill, or by rollers. When thus reduced, the heavy metallic matter is separated from the lighter earthy matter by washing. The common mode of effecting this is to put the powdered metal into a riddle or sieve, immersed in a large tub of water, wherein it is agitated by a movement that washes away the small particles through the sieve, and ejects the lighter portion of the matter over the sides of the sieve; while the metallic portion, from its specific gravity, is less disturbed, and is collected at the bottom of the sieve. Some improved apparatus for this purpose was patented by Mr. Harsleben, in 1827, the description of which will be found under the article MINING. In some establishments in this country, and very generally abroad, the ores are washed upon inclined tables, which are shook by machinery, whilst water is made to flow over them to separate the metallic from the less ponderous matter; which apparatus is also described under the article MINING, as it is equally applicable to other ores as to the ore of lead.

An improvement in the furnaces for smelting lead ores was patented by Mr. Joseph Wass, of Ashover, Derbyshire, the main object of which was to obviate the injurious effects upon animal and vegetable life within the range of the metallic vapours emanating from furnaces of the usual construction. But in addition to this important desideratum, there results from the adoption of this improved arrangement a considerable profit, which arises from the product obtained by the condensation of those volatile and deleterious substances that are usually allowed to mix with the atmosphere. In the specification which is before us, the patentee states,—“By the employment of this improved apparatus, smelting and calcining furnaces are divested of their pernicious effects, and such works may in future be erected in any convenient situation, either near to dwelling-houses, or by the side of public roads, or on the banks of navigable rivers or canals; and thus, in many cases, produce a very great economy in the expense of carriage. The saving effected by this apparatus in preserving a quantity of valuable matter, which would otherwise, as heretofore,

escape, to the injury of the neighbourhood, would of itself amount in one year, where four furnaces are employed (as described in the plan) to a sum equal to the entire cost of the improved apparatus; that is, the upper part of the tower, with its roof, cap, vane, shutter, and appendages" which we shall next proceed to describe.

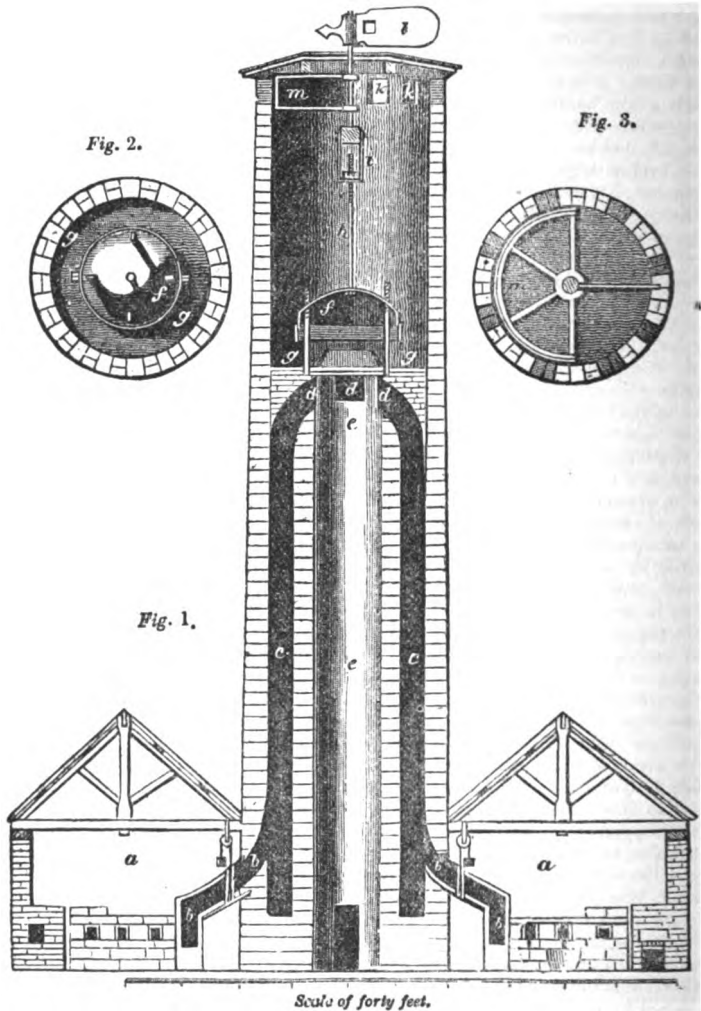


Fig. 1, in the preceding engraving, represents a vertical section of a lofty and capacious tower, placed in the centre of four smelting furnaces, and receiving, by distinct flues, the smoke and vapour from each of them. The drawing being a central section, but two of the furnaces are brought into view, which are marked *a a*, their flues *b b* opening into separate chimneys *c c* in the tower, which they ascend for twenty or more feet; then, by lateral passages at *d d d*, they respectively enter the central shaft *e e*; here the vapours come

in contact with a powerful ascending current of cold air, and are likewise checked in their upward progress by striking against a dome or cap of iron *f*, which is suspended over the throat of the central shaft *c*. The ascending vapours thus intercepted and acted upon are, for the most part, immediately condensed, and the metallic particles are precipitated upon a floor *g*, called the *ledge floor*. A plan of this floor, and the cap *f*, are given in a separate figure (2), which is a transverse horizontal section of the tower just above the cap; another advantage resulting from this arrangement consists in the effect produced in the furnaces below, where it is found that the carbonaceous matter is more completely consumed than by the former disposition of things; such portion of the heavy particles that do not fall upon the ledge floor are precipitated to the bottom of the central shaft. The cap *f* is suspended by a vertical rod *k*, which is connected to a transverse beam by means of a sort of stirrup-iron *i*, through which the upper extremity of the rod is screwed, and by the turning of a nut upon this screw the height of the cap above the throat of the central shaft is regulated. The cap is steadied in its movements and preserved in its position by several upright bars passing through it, two of which are brought into view; these are perforated with holes, through which keys or bolts are put to lock the cap securely in its place. The lower part of the cap or dome is circumscribed by a broad hoop; by the action of regulating screws, this hoop is shifted up or down over the periphery of the cap, and the passage for the vapours is thus more readily adjusted at pleasure. The more volatile portion of the vapours pass from under the dome, and ascend to the top of the tower, which, being covered with a roof nearly flat, the heaviest particles are driven back, and fall condensed also upon the ledge floor, while the lightest and least pernicious escape into the atmosphere at the lateral openings *kk*. There are a regular series of vent holes all round this part of the tower, one half of which (those that happen to be windward) are always closed by a shutter *m*. The lower extremity of the shaft, upon which the vane *l* is fixed, turns in a bearing upon the cross beam; and the arms of the circular shutter being also attached to this shaft, when the wind turns this vane the shutter is, consequently, in like manner turned against it.

Fig. 3 is a transverse section of the tower immediately under the roof, by which the circular frame of the shutter is shown, as closing one half of the apertures, or those to windward of it. When the deposition from the condensed vapour has become considerable, it is removed from the ledge floor at a time when the smelting furnaces are not at work; this is done by a man ascending a narrow circular staircase, constructed in the masonry of the tower, up to the ledge floor, where he throws down the accumulated deposition with a shovel to the bottom of the shaft; from thence it is barrowed out, and carried to a roasting furnace. When any one of the furnaces is not at work, communication with the tower is to be cut off by means of a damper, as those shown at *o o*. In the drawings attached to the specification, a general plan of a smelting work is delineated. The area is inclosed by a quadrangular wall, with a smelting furnace on each side, the chimneys of which are conducted into the central tower. The corners of the quadrangle are occupied by the other buildings required in such establishments. The spaces between the angles of the several flues, the patentee states, may be conveniently occupied by small furnaces for tests and experimental purposes. Another improvement of the patentee deserves mentioning: he directs that the tapping sides of the contiguous furnaces be made "opposite" to each other; by which is meant that they may both face the area which lies between them, in order that the fluid metal from the pans of each surface may be run into pigs, or conveyed into one receiver, and thence into moulds, so as to be formed into thick sheets, ready for milling or rolling, by which arrangement of the furnaces it is considered an important saving of labour and expense will be effected, and the waste by remelting the lead avoided. In the process of smelting, the ore is spread upon the concave hearth, so that the flame may act upon it, and release the sulphur. When the sulphur has escaped, the lead combines with the oxygen, and the oxide of lead thus formed combines with and reduces the earthy matter to a liquid, which

floats upon the surface of the metal, and, for the remainder of the operation, protects it from the action of the oxygen. The temperature of the furnace is now considerably raised, to separate as quickly as possible the lead from the liquid scoria; after which a considerable portion of the scoria is tapped off, leaving only so much behind as is necessary to protect the metal from the action of the oxygen. The fire is now slackened, and a quantity of slack or refuse pit-coal thrown into the furnace, which serves to diminish the heat, and to concrete the melted scoria, which effect is promoted by the addition of powdered lime; the scoria thus consolidated is broken into pieces with a rake, and thrust to the opposite side of the furnace, where it is taken through the apertures already mentioned. The lead is now tapped in a manner similar to that described in the manufacture of iron, and allowed to run into a capacious iron pan, whence it is ladled into moulds to cast it into pigs. When the ores abound with blend, or black-jack, or with the sulphate of iron, fluete of lime is added as a flux. The scoria last mentioned contains a portion of lead, besides that which is in the state of oxide; it is therefore exposed to the heat of another furnace, being a species of blast furnace, and called a slag-hearth, which fuses the scoria and causes the metal to penetrate through it and fall into a cavity, where it is protected from the agency of the blast, and from whence it is taken and cast into pigs. All lead ores contain some portion of silver, which is extracted when it is in sufficient quantity to afford a recompense for the operation; the method adopted in France is very simple and efficacious, and is thus described in *Rees's Cyclopædia*:—"A shallow vessel, or cupel, is filled with prepared fern-ashes, well rammed down, and a concavity cut out for the reception of the lead, with an opening on one side for the mouth of the bellows, through which the air is forcibly driven during the process. The French smelters cover the surface of the ashes with hay, and arrange symmetrically the pieces of lead upon it; when the fire is lighted, and the lead is in a state of fusion from the reverberation of the flame, the blast from the bellows is made to play forcibly on the surface, and, in a short time, a crust of yellow oxide of lead or litharge is formed, and driven to the side of the cupel opposite to the mouth of the bellows, where a shallow side or aperture is made for it to pass over; another crust of litharge is formed, and driven off. The operation continues about forty hours, when the complete separation of the lead is indicated by a brilliant lustre on the convex surface of the melted mass in the cupel, which is occasioned by the removal of the last crust of litharge that covered the silver. The French introduce water through a tube into the cupel to cool the silver rapidly and prevent its spirting out, which it does when the refrigeration is gradual, owing, probably, to its tendency to crystallize. In England the silver is left to cool in the cupel, and some inconvenience is caused by the spirting, which might be avoided by the former mode. The silver thus extracted is not sufficiently pure; it is again refined in a reverberatory furnace, being placed in a cupel, lined with bone ashes, and exposed to greater heat; the lead, which has escaped oxydation by the first process, is converted into litharge and absorbed by the ashes of the cupel. The last portions of litharge in the first process are again refined for silver, of which it contains a part which was driven off with it. The litharge is converted into lead again, by heating it with charcoal; part is sometimes sold for pigment, or converted into red-lead. The loss of lead by this process differs considerably, according to the quality of the lead. The litharge commonly obtained from three tons of lead amounts to fifty-eight hundred weight; but when it is again reduced to a metallic state, it seldom contains more than fifty-two hundred weight of lead, the loss on three tons being eight hundred weight. The Dutch are said to extract the silver from the same quantity of lead with only the loss of six hundred weight."—See SEPARATION.

*Sheet Lead.*—There are two distinct kinds of sheet lead, cast, and milled or rolled. The first-mentioned is the original kind, and as it is preferred we shall first describe it as usually practised by the plumbers. A large cast-iron cauldron is built over a furnace, enclosed in solid masonry, at one end of the casting-shop, and near to the mould or casting-table. This table is generally

of the form of a parallelogram, about six feet wide, and twenty feet long, substantially made of wood, and bound together at the corners and other parts with iron. The face of the table is surrounded by a raised border about three inches thick, and five inches in depth; the legs and framing are of course strong and firmly jointed, to prevent any yielding or trembling during the casting. The top of the table is of boards, laid very even, and this is covered by a stratum of fine sand laid very smooth and even; at the end of the table, nearest to the cauldron in which the lead is melted, is adapted a box, equal in length to the width of the table; at the bottom of the box is a long horizontal slit, through which the metal flows out uniformly over the breadth of the table; this box is mounted upon rollers, which run on the rim of the table as a railway, and is set in motion by a rope and pulley. When the metal in the cauldron is sufficiently heated to retain its fluidity throughout the spreading of the sheet, the requisite quantity of it is ladled into the casting-box, and the dross taken off its surface by means of a perforated scummer. As soon as the box has dispersed its contents upon the table, a man levels the surface with a striker, which takes off the impurities also, before it cools; as soon as it has set, the edges are taken off in a straight line, and when sufficiently cool it is rolled up and removed away to make room and prepare for the succeeding castings, which are conducted in a similar way.

A method different from the foregoing is practised in some places. Instead of a casting-box travelling over an horizontal surface, the table is a little inclined, and an iron vessel at the upper end of the table next to the cauldron is tilted so as to pour out the fluid which flows to the other end, during which operation a workman levels the surface with a striker or straight edge, which reduces the mass to a uniform thickness. Cast sheet-lead, made by these processes, does not possess that very uniform thickness, nor that smoothness of surface which distinguishes milled-lead, or such as has been laminated between large powerful rollers, actuated by a steam engine or other suitable prime mover. The method by which this is done on the large scale is as follows:—A cauldron, capable of melting ten or more tons of metal at a time, is substantially erected over a common furnace; when the lead is at that temperature above the melting point, which will prevent its congelation before it has flowed to the remotest part of the mould, the vessel is tapped by the pulling out of a plug; this plug is attached to a bent extremity of a lever of the first class, the other arm of which is loaded with a weight, that acts as a compressing force to keep the plug in the tapping hole; a rope attached to the end of the loaded arm of the lever, and passing over a pulley, being pulled by a workman, the plug is thereby easily withdrawn; and upon the workman letting go the rope, the weight upon the lever forces the plug into the hole again. (Owing to the pressure of the superincumbent portion of the metal in the cauldron above the tapping-hole, the lead is spirted with considerable force around the plug at the moment of its entering or leaving the tapping-hole, which renders it dangerous to persons standing within the distance of a few yards; and as this dangerous effect might easily be prevented, we wonder that it is not done; such as applying a lateral screen to the tapping-hole, or the plug, and making the plug, as a tap-hole, cylindrical, instead of conical.) The metal is discharged into a very large square cast-iron pan, laid perfectly level, and capable of holding a plate of lead about an inch and a half thick, and weighing about five tons; when cold, the cast-iron pan or mould is hooked at the corners to chains, in the manner of a scale-board, and by the assistance of a large jib extending over it, and a powerful crane, is raised from its seat and swung round upon a table upon a level with the laminating rolls. On this table, the plate is now divided into five, six, or more narrow plates, the numbers and dimensions of these depending upon the size and weight of the sheets to be made from them. The division of the plate is effected by very rude means; one man, holding an ash-rod, applies a cold chisel at the end of it to the chalk division line scribed on the plate, whilst another workman, with a sort of sledge-hammer, made of a great lump of lead, at the end of a long handle, swings it round vigorously, and gives the chisel such heavy thumps as to send it through the thick plate of lead at each blow.

The laminating rollers are cast-iron cylinders, usually about eighteen inches in diameter, and about six feet long, turned and ground to a very true and smooth surface; the lower roller turns in fixed bearings, but the upper in adjustable bearings, which are acted upon by screws for regulating the distances between the rollers. The power is communicated to the lower roller through the medium of a reversing motion, which causes the rollers to change the directions of their respective rotations, according as the sheet of lead may be on one side or the other of them; on either of which it is supported upon a species of table, from twenty to thirty feet long, the surfaces of which are composed of a series of wooden bearing rollers. The plate of lead being introduced between the cylinders, is gripped by them, and forced through by their revolution: the plate is thus extended by a reduction of its thickness, and is received upon the bearing rollers on the surface of the table; the workmen on each side of the machine now give the regulating screws a turn, by which the laminating rollers are brought nearer together; then the motion of these rollers is reversed, and the sheet of lead traverses back through them to the opposite side, where it is received on the bearing rollers of that table, considerably extended; the rollers are again adjusted nearer together, and the motion of them is again reversed for the next rolling through; the operation being thus repeated until the plate is brought to the required thickness. When this is done, the rough edges are cut off to a straight line, and the sheet rolled up off the table on to a truck adapted to the work, and wheeled away. Whilst this is being completed, another plate of lead is passing through the laminating rollers; and whilst all the plates of lead divided from the great cast-plate before-mentioned are being laminated in the manner of the first described, the casting department of the establishment is engaged in preparing to cast, or in casting another great plate, which is subsequently divided and placed in readiness for the continuation of the laminating operation.

The very thin sheet-lead, with which the tea-chests from China are lined, is made, according to common report, in the following manner:—A man sits upon a floor with a large flat stone before him, and another movable one at his side on a stand; his fellow-workman stands beside him with a vessel full of melted lead, and having poured out a certain quantity on the large flat stone upon the floor, the other immediately lifts the movable stone, and dashing it on the fluid lead, presses it out into a flat and very thin plate; the stone and lead are then quickly removed, and the operation renewed, which is repeated in quick succession. The rough edges are afterwards cut off, and the sheets soldered together for use.

*The Tinning of Sheet-Lead* may be effected in two ways. *First*, place the sheet of lead upon a hot stove, until it acquires sufficient heat to keep melted tin poured upon it in a fluid state; then throw a little powdered resin over the sheet, and when it has melted, with a greasy rag rub the tin and resin over the sheet of lead until it is completely covered with the tin; after which, wipe off the superfluous matter. *Secondly*, the tin in the cold state, and in small quantities at a time, may be laid on the plate of lead, carefully heated sufficiently to fuse the tin, (but not more so,) and by the help of resin and similar manipulation to the first-mentioned plan, the lead may be perfectly coated.

*Lead Pipe.*—The next article of importance in the lead manufacture is pipe or tubing. There have been various modes of producing it: the original mode, from some specimens of very old pipe that we have seen, appears to have been the wrapping of a strip of sheet lead, with parallel sides, round a cylinder, so as to make their edges meet, and then unite them with solder. The specimens alluded to present phenomena worthy of notice in this place: the lead was full of holes, and was corroded more or less in every part, except at the seam, which the solder had entirely protected; and the solder itself was as sound and perfect as when it first left the plumber's hands.

Another mode of making lead-pipe, which probably succeeded the foregoing, and is still practised by some plumbers, is the following:—An iron mould is provided, which is divided into halves, and forms, when put together, a hollow cylinder of the external diameter of the extended pipe; in this cylinder is put

an iron rod or cord, extending from the top to the bottom, and leaving all round a space between it and the cylinder of the intended thickness of the pipe. The lead is poured in at a spout, formed by two corresponding notches cut in each half of the mould, and a similar hole is made at another place for the escape of air. The mould is fastened down upon a bench, upon which, at one end, and in a line with its centre, is a rack moved with toothed wheels and pinions. When the pipe is cast, a hook at the end of the rack is put into an eye at the end of the iron core, which, by the action of cog-wheels and pinions, is drawn so far out that about two inches of it only remain in the end of the pipe; the two halves of the mould, which fasten together by wedges or screws, are now separated from the pipes, and are fastened upon the iron core, and the two inches of lead-pipe attached to it. Melted lead is now again poured into the mould, when the fluid lead unites with the end of the first piece of pipe; and this process being continued, pipe of any required length may be made.

A third method, which was patented in 1790 by the great iron master, John Wilkinson, consists in casting a very thick pipe in a mould, having a cylindrical core of the same diameter as the intended pipe, and then inserting a polished iron mandril up the bore of the pipe, in which it is to be successively passed through a series of round grooves, precisely in the same manner as has been described under our article IRON, for making round bars. Every time that the pipe is passed through, the lead is compressed upon the mandril, consequently reduced in its thickness, but extended in length, while the internal bore remains unaltered, except the improvement it derives from condensation of the metal against the polished mandril.

A fourth method is mentioned in Mr. Wilkinson's specification, which, since the expiration of the patent, has been, and is still practised with unimportant variations by all the considerable manufacturers of lead pipe: it consists as follows:—Very thick short pieces of pipe are cast, similar to those described in the preceding method; the external diameter may be two or three times that of the intended pipes, but the internal the same. The central hole for the mandril of a triblet does not extend the entire length of the pipe, but terminates with a much smaller hole at the extremity; a stop to the triblet is thus formed, which is employed in the succeeding operation, which is that of drawing the lead pipe through a hole precisely in the same manner as wire is drawn. The triblet or polished mandril is of somewhat greater length than the pipe intended to be manufactured by it, which is commonly from nine to twelve feet. Through the small hole of the cast-lead pipe is then passed a screw, which is screwed into the end of the triblet, that abuts against the shoulder; and it is by this connexion with the triblet that the lead pipe is drawn successively through a series of separate steel plates, each having a different sized hole, and which are successively deposited in solid recesses made in very firm bearings, and are exchanged for smaller after the pipe has passed through the larger one. The table or draw bench on which the operation is conducted is usually about 30 feet in length; it is provided with a strong endless hitch-chain passing around chain wheels at the ends of the bench, to one of which the power is communicated. The screw fastened to the end of the triblet passes through the draw-hole, and is then secured by a hook and eye, or other fastening, to the endless chain; the machinery being then thrown into gear by the ordinary means, the chain drags the lead through the steel hole, by which its dimensions are reduced, and its length increased. The motion of the chain is now reversed, either by machinery connected with the power, or the chain is thrown out of gear with the power, when the chain can usually be drawn back by hand, and the draw plate changed; when, by throwing into gear again, the work is renewed, and so continued until reduced to the required dimensions; a small piece of each end of the pipe being cut off it is finished.

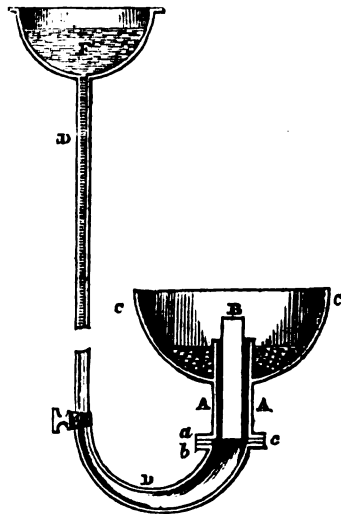
A very ingenious mode of *casting* lead pipe of any length by a continuous process, was invented by Mr. John Hague, and patented by him in 1822, which we ought not to omit noticing in this place. A rectangular cast-iron vessel, containing the lead, was placed over a suitable furnace, to melt and preserve it in a fluid state; through this vessel, in a horizontal direction, was passed a



very stout cast-iron cylinder, each end of which came to the outside of the vessel, at a short distance from which they were each connected to a small reservoir of water to keep them cool. A hole about half an inch in diameter was made in the upper side of the cylinder through which the latter was charged with the fluid metal, and the hole was then stopped by a plug screwed down from above. The internal diameter of this cylinder was about six inches, and throughout its length of two feet its surface was cut into a screw thread; and into this a solid screw plunger worked from one extremity, which by its revolution gradually forced the metallic fluid through a mould and core fixed at the end, where the pipe was constantly drawn off as it solidified (by the cooling influence of one of the before-mentioned reservoirs of water) on to a drum, loaded with a weight upon its axis, which caused the drum to turn round with just sufficient force to wind the pipe upon it as it was formed.

A different method of casting lead pipe continuously, has lately been patented in the United States of America by a Mr. Titus, which is thus described in the *Franklin Journal*, with reference to the subjoined cut, which represents a vertical section of the essential parts of the apparatus.

A A is a hollow cylinder of metal, bored out, so that its inner diameter shall be equal to that of the pipes intended to be cast. Its length, for a pipe of  $1\frac{1}{4}$  inch may be about 8 inches. It has a flanch *aa* at its lower end. This tube gives the form to the outside of the tube to be cast. B is a plug or core, adapted to the inside of the pipe, and made of iron or other suitable metal; it must be perfectly smooth and slightly tapering, being smallest at top. It has a flanch *bb* adapted to the flanch *aa*; this flanch is perforated with a number of holes, to allow the fluid metal to pass up into the mould. C C is a basin to contain water standing up to the dotted line *ff*. D D is a tube by which the melted metal is to be conveyed from the melting-pot F into the mould. A stop-cock regulates the flow of the metal. The tube D D is furnished with a flanch *c*, by which it is connected with the mould. The melting-



pot may be placed so high up, that the pressure of the melted metal will be sufficient to force the pipe from the mould, with a regular motion, as it is cooled by the water; this force being regulated by the quantity admitted by the stop-cock. The pipe D D must descend through a flue kept sufficiently heated to keep the lead in a fluid state, and heat must also be applied at its junction with the mould. Instead of elevating the melting-pot, an arrangement may be made for making a mechanical pressure upon the surface of the lead, and thus to produce the same effect. The pipe, as it is forced off, may be received upon a reel or drum placed above the mould. Under proper modifications, which experience alone must suggest, the principle described in this and Mr. Hague's process may be advantageously applied to the accomplishment of the object proposed.

In the application of lead pipes as conduits for beer, wine, vinegar, and other acid liquors, serious objections have been made by many scientific writers, on the ground that poisonous solutions of the metal are thereby formed. The editor of *The Chemist*, observes in Vol. I. p. 227, that "wherever water kept in leaden vessels is allowed to come into contact with air, the lead becomes oxydated; and though the water has no direct action on the lead itself, it has

as this oxide; it dissolves a portion of it, and becomes poisonous;" and Mr. S. F. Gray, author of several pharmaceutical works, says in his *Operative Chemist*, p. 392, "the use of lead for cisterns, or even pipes, ought to be discontinued." Mr. John Warner informs us, that soon after the introduction of the convenient hydraulic apparatus employed by publicans, called beer engines, it was found that that portion of the beer which filled the *leadens* conducting pipes from the casks in the cellar, and had remained therein during the night, or for several hours during the day, had obtained a flat, bad taste, and was highly deleterious, owing to the lead it had dissolved during that time. This alarming discovery nearly caused the abandonment of beer engines. Attempts were made to substitute pipes made of other metals or alloys, but without success; for leaden pipes still continue to be used, but with the necessary precaution on the part of the publican, or other vendor, to draw off and *waste* the beer contained in the pipes, amounting to several pints or quarts every morning; and this precaution is sometimes resorted to during the day.

To obviate the disadvantages attending the use of lead pipes, the skill and attention of many ingenious men have been exercised. The first, we believe, were Messrs. John and George Alderson, who contrived to put an interior case of tin to lead pipe; but they did not succeed in making a firm junction between the two concentric pipes. Alderson's method was, however, improved upon by Thomas Dobbs, of Birmingham, who took out a patent in December 1820, for the process, which is entitled a "new mode of uniting together or plating tin upon lead." The patent includes the tinning or plating of ingots and sheets of lead, besides that of pipes; the process with respect to the latter is thus described in the specification:—"First, in order to unite tin with lead-pipes, or to coat, cover, or plate them with tin, I take the pipe hot from the mould in which it has been cast, and lay it horizontally upon a bed of hurds, rags, or tow, which has been previously prepared or impregnated with turpentine, or other resinous substance, a small quantity of melted tin having been also previously put on the said bed of hurds, rags, or tow, prepared or impregnated as aforesaid with turpentine, or other resinous material, until the surface of the pipe is completely tinned. I then attach to the end of a rod or wire a bunch of hurds, rags, or tow, prepared or impregnated as aforesaid with turpentine, and introduce it within the pipe, together with a little melted tin, and work the bunch up and down, in manner of the piston of a pump, until the inside is also tinned. I then place or fix the pipe in a larger pair of moulds, so as to leave a vacancy also between the pipe and the mould; and I also introduce and fix a small core into the centre of the lead pipe, leaving a vacancy also between the pipe and the core. I then take melted tin out of a furnace, and with a ladle I pour the tin down the two vacancies before-mentioned, by which means the two bodies are perfectly and soundly united, and the lead pipe is united or plated both inside and outside with a thick coating of tin. In this state it is then ready for drawing or rolling, whichever may be the most convenient. It is not necessary that the tin should be quite pure to be united to lead by this mode, but it may be alloyed with other metals. The moulds and cores I use are the same as those generally employed by lead-pipe makers, excepting that I prefer them made of copper or brass, instead of wrought and cast iron." Tin being a much harder and less ductile metal than lead, considerable difficulty was found in drawing them together, so as to get them sound in every part; frequent cracks and flaws being discovered in the tin, which would not so readily yield as the lead to the forcible extension they underwent. From this circumstance, and the greater rigidity of the tin, they could not be made to sustain the bending to which lead pipe is necessarily subjected by the plumber; they were not therefore successfully brought into use. About the same period also pipes were drawn of pure tin, and rendered at a price lower than the tin coated pipe could be afforded.

There being, however, no other known metal which possesses the same degree of flexibility and durability as lead, it was still deemed a most important desideratum to give a perfect coating of tin or other innocuous metal to lead pipe, without impairing the flexible or other valuable properties of the latter; and

this we are happy to add has been supplied by a new process, very recently patented by Mr. John Warner, jun.; the specification of which describes that process to be as follows:—A bath of melted tin is prepared in a vessel of a suitable form and size, which may vary according to the size of the pipe to be tinned, (or the size and shape of any other leaden article to be tinned.) The heat of the bath is to be so regulated that the metal shall continue in a fused state, but not at a higher temperature than is necessary for that purpose, lest the lead when immersed should be melted thereby; the heat may be ascertained by the use of a thermometer, or a pyrometer; likewise by testing it by such alloys of tin and lead as will melt at certain given temperatures, between the melting point of tin (or such alloy of tin as may be used as a substitute for the pure metal,) and that of lead, *when placed under the influence of a bath of melted tin.* This, the reader will observe, is a very nice point, and can only be practised by great skill and attention on the part of the workmen; for although tin melts at about 440° and lead at 612° of Fahrenheit's thermometer, yet, when they come together, an alloy is produced at the immediate points or surfaces in contact, whose fusibility is much lower than even that of tin; so that when, by mismanagement, the heat is raised a few degrees too high, a quantity of the lead in the form of an alloy runs off the pipe into the bath; and if, on the contrary, the heat be suffered to fall a few degrees too low, the tin is not sufficiently fluid, and deposits itself upon the lead in a thick and uneven coat. When the pipes are to be tinned all over, the external surfaces are sprinkled with powdered resin, and the same material is blown up the pipes so as to cover their internal surfaces with it; a mixture of oil and resin boiled together is, however, preferred to the resin alone. The said mixture is to be spread over the surfaces of the lead pipes by any convenient means, and when they have been so prepared, they are to be passed through, or immersed in the bath of melted tin, which should be covered with fat, oil, or resin, to prevent the oxidation of the fluid metal, and to aid in the tinning. But when the pipes are to be tinned on one side only, or partially, those parts which are *not* to be tinned are covered with a mixture of lamp-black and size, or with any other matter that will prevent the action of the tin upon the lead; and those parts that *are* to be tinned are to receive the powdered resin, or the mixture of oil and resin, as before mentioned. The pipes thus prepared are then to be passed through, or immersed in the bath of liquid tin, by which process they will be tinned only in the parts required. When the pieces of pipe to be tinned are of a small size they may be easily managed by hand; but when they are of considerable weight or length, a rope and pulley is resorted to, to draw them through the bath of melted tin: the form of the bath is that of a segment of a cylinder having two flat sides; the chord of the segment being the top or open part of the vessel, where it forms a parallelogram of about six inches wide and two feet long. This form, it will be perceived, accommodates the bended form of the pipes, to dip in at one end of the vessel, and curving round the bottom, to come out at the other end; the tin thus flowing in at one extremity of the pipe, and running out at the other. This process, as we have had occasion to notice, gives a perfect coating of tin, and fills up any minute fissures or holes that there may be in the pipe, besides enabling the manufacturer to give the pipe any required thickness of coating, by drawing it any number of times through the bath. But an extremely minute quantity of tin covers the surface effectually, and by not impairing the flexibility of lead, adapts it to every purpose to which both lead pipes and tin pipes are used, and at the most trifling cost above that of lead.

*Strength of Leaden Pipes.*—Some experiments upon this important subject were made by Mr. Jardine, of the Water Company in Edinburgh. The method of proving was to close one end of a piece of pipe, and then inject water into it by means of a forcing pump attached to the other end, the force or pressure being measured by a gauge belonging to the pump. When the water from the injecting pump begins to press out the pipe, little or no alteration is observed in it for some time. As the operation proceeds, however, the pipe gradually swells throughout its whole length, until, at last, a small protuberance is observed rising

in some weak part, which increases until the substance of the pipe, becoming thinner and thinner, is at last rent asunder. In the first experiment, the pipe was of one and a half inch bore, and the metal, which was remarkably soft and ductile, was one-fifth of an inch in thickness. This sustained a power equivalent to that of a column of water one thousand feet high, equal to thirty atmospheres, or 420 lbs. per square inch of internal surface, without alteration; but with a pressure equal to twelve thousand feet of water it began to swell, and with fourteen thousand feet, or six hundred pounds on the square inch, it burst. When measured after the experiment it was found to have swelled until of a diameter of  $1\frac{1}{4}$  inch. The edges of the fracture were not ragged, but smooth like a knife. In a second experiment, the pipe was two inches in diameter, and one-fifth of an inch in thickness. It sustained a pressure equal to that of a column of water eight hundred feet high, with hardly any swelling, but with one thousand feet it burst; the fracture in this was not so fine as in the former instance, the metal being much less ductile.

*Red Lead and Litharge.*—We have described, at page 52, the method of refining lead for obtaining the silver which it usually contains, by which process there results an oxide of lead, called *litharge*. The use of this substance for making oil and oil paints dry sooner is well known; it remains to be observed in this place, that it is the material from which red lead is made. The litharge is put into pots, and exposed to the action of flame in a reverberatory furnace for forty-eight hours, during which time it is frequently stirred; hence it acquires the orange-red colour, termed minium, or red lead. There are other modes of obtaining red lead. In Germany and some other places, metallic lead is calcined on the hearth of a cupola furnace, and constantly stirred for eight hours; then left in the furnace for sixteen hours more, stirring only at intervals. The massicot thus produced is then ground in a mill, washed, dried, and put into earthen pots, so as only to make them about a quarter full, in which they are exposed to the action of flame, enveloping them in a furnace for forty-eight hours, by which time, the colour being fully developed, the pots are taken out, and their contents passed through sieves to separate any foreign or gross matter. A hundred pounds of metallic lead thus produces about a hundred and ten pounds of red lead; the increase arising from the absorption of oxygen. The specific gravity of red lead is 8.94.

*Sugar of Lead* is obtained by dissolving the metal in acetic acid, concentrating the solution, and crystallizing.

*Turner's Patent Yellow*, now almost entirely disused, may be obtained by pouring upon litharge, one-third of its weight of muriatic acid, and, after letting it stand for twenty-four hours, melting the whitened litharge, by which it becomes yellow. Goulard's extract is made by boiling litharge in vinegar.

*Chromate Yellow.*—This beautiful colour, which has superseded the use of the last-mentioned pigment, is obtained by precipitating a solution of lead in acetic acid, by the addition of a solution of the chromate of potash.

Lead is rapidly dissolved by the nitric acid. Wooden sticks, impregnated with a nitric solution, made by dissolving the cuttings of lead in weak nitric acid, have been recommended by Proust, as a substitute for port-fires, in discharging artillery. Most of the acids attack lead. The sulphuric does not unless it be concentrated and boiling. When lead is alloyed with an equal weight of tin, it ceases to be acted upon by vinegar. Oils dissolve oxide of lead and become thick and consistent, in which state they are used as the basis of cements for water works, the vehicle for paints, and various other purposes. Sulphur dissolves lead in the dry way, and produces a brilliant and brittle compound, which is much more fusible than lead itself. Lead unites with most of the metals. Gold and silver are dissolved by it at a light red heat. Platina forms a brittle compound with lead; mercury amalgamates with it, but the lead is again separable from it by mere agitation, in the form of an impalpable black powder. Copper and lead do not unite without a strong heat; but the union of these metals is extremely slight, for at no greater heat than the melting point of lead it runs from the copper. Iron does not unite with lead in the metallic state. Tin unites very readily with lead, as already shown

in the process of tinning lead pipes and sheets. The compound of these metals being very fusible, it is used as a solder either separately or both together. The mixture is made in various proportions: the *best* solder is said to be two parts tin and one part lead; and the common solder, two parts lead and one part tin. Bismuth combines readily with lead, and affords a metal of a fine close grain, but very brittle. A mixture of eight parts bismuth, five lead, and three tin, melt at a heat below that of boiling water. Antimony forms a brittle compound with lead: see the article *ALLOY*. Nickel, cobalt, manganese, and zinc, do not unite with lead by fusion.

**LEATHER.** The skins of animals, combined in a variety of ways with astringent and other matters, to adapt them to numerous purposes of utility. The art of preparing leather is very ancient, and is practised in almost every country of the world by nearly similar processes. The objects obtained by this art, are, the prevention of their destruction by putrefaction; the rendering them strong, tough, durable, and impervious to moisture; and in giving them a bright and beautiful appearance by dyeing and polishing; according as these qualities may be required. The preliminary operation in making all kinds of leather, is the separation of the fleshy and other foreign matters adhering to the skin, the animal juices retained in its pores, and also the cuticle with its hairy covering, excepting in those instances wherein the wool is required to be left on, as in the case of sheep-skin rugs. The skins, after being duly purified, and their texture opened so as to adapt them to imbibe other matters in solution, are made into leather by two different processes, one called *tanning*, and the other *tawing*; and both these processes are sometimes combined in sheep, goat, and deer skins, by tawing first and tanning afterwards, in a slight manner; and a large proportion of the tanned hides of the horse, ox, and other large animals, undergo an operation called *currying*, to render it flexible, and resist water. There are many trifling variations in the processes adopted by different tanners and leather-dressers with respect to the same kind of skins, and each kind is treated differently in some respect, either in consequence of its natural peculiarities, or the application to which it is designed when finished. Our descriptions will, therefore, apply to the general mode of proceeding in the principal sorts of leather.

The thin skins of cows, calves, and others of a similar texture, are soaked for two or three days in a pit of water to free them from dirt, blood, and other matters that may slightly adhere to them. They are then taken out, and laid upon a horse or beam, (which is usually a semi-cylindrical piece of timber, or the rib of a whale,) whereon they are scraped and pared, to free them from any adhering flesh, fat, &c. The hides are next immersed in a pit containing milk of lime, wherein they are frequently stirred, and are allowed to remain until the cuticle of the skin is so far destroyed as to be easily rubbed or pared off along with the hair to which it is connected. When this is found to be the case, they are taken out, stretched upon the beam, and with a large two-handed blunt-edged knife the workman scrapes off the hair. In lieu of this liming process, in some places, the hides were formerly piled wet one upon another, and covered over with spent bark, (or otherwise kept warm in what was called a smoke-house,) until the cuticle and the hair would readily come off. The absorption of lime in the before-mentioned process makes the skins hard and thick; to render them supple, and prepare them for receiving the tan liquor, they are thrown into a pit called the *poke*, or *mastering-pit*, which contains a quantity of putrescent dung diffused in water: the dung of dogs, pigeons, or sea-fowl, is preferred for this purpose, that from cows and horses not being sufficiently powerful. During the process they are frequently well stirred, and sometimes taken out of the pit, piled up, and put in again. When the skins have become perfectly soft, they are taken out of the putrescent pit, and cleansed on the beam, when they are ready for tanning. The large thick hides of the ox or boar, intended for the toughest sole-leather, being not so liable to sudden injury as the thinner skins, are frequently cleared of their hair and other matter without resorting to the liming process. They are allowed to ferment, piled up in a warm place, and the putrefactive process

is carried farther, that the cuticle and hair may be easily removed. When this has been done, they are immersed for several days in sour liquor, made from fermented barley, or rye meal; the acid is generated in the process, and seems to be the active agent in softening and opening the texture of the skin, assisted by the continuance of the fermentation, of which the skin partakes. This process, which always precedes that of tanning, is called raising, as it has the effect of considerably swelling the skin. Instead of the foregoing acid, some tanners use very dilute sulphuric acid, in the proportion of about four pounds to a hundred gallons of water.

The process of tanning is essentially the same in all skins. It consists merely in immersing the skin for a sufficient length of time in an infusion of oak bark, or other vegetable astringent, until it is completely saturated with it. Hence the art of preserving the hides of animals by this method is one of the most ancient and universal of all manufactures, no apparatus whatever being required to perform it, except a pit or hole for water, in which the tanning vegetable may be put, and the skin thrown in along with it. Almost equal simplicity is observed in the most improved methods of tanning, the art mainly consisting in judiciously regulating the strength of the tanning infusion, and in the manipulation of stirring the hides in such a manner, that all that are in a pit may be equally impregnated.

The substance used in this country is chiefly oak bark, which is ground into a coarse powder, and is thrown into pits with water, by which an infusion of the tan, and other soluble parts, is made, which is technically called *ooze*. The hides, (previously prepared in one or other of the ways before mentioned,) are first put into small pits, with a very weak *ooze*, where they are allowed to macerate for some weeks, with frequently stirring, or handling, as it is termed. As the process of tanning proceeds, the strength of the different *oozes* is gradually increased, after which, the half-tanned hides, (if of the thick kind, intended for sole leather, and which require very complete tanning,) are put into larger pits, with alternate layers of ground bark, in substance, till the pit is filled, over which a heading of bark is also laid, and the interstices filled up with a weak *ooze* to the brim. The hides are by this arrangement supplied with a quantity of fresh tan in proportion as they absorb the tan, previously dissolved in the water. By this mode of tanning, the thickest leather takes fifteen months before it is thoroughly tanned throughout; which is ascertained by cutting a piece off the edge of the hide, when it should appear uniformly throughout its thickness of a nutmeg-brown colour, and any portion that is not tanned will exhibit a whitish or pale-coloured streak in the middle.

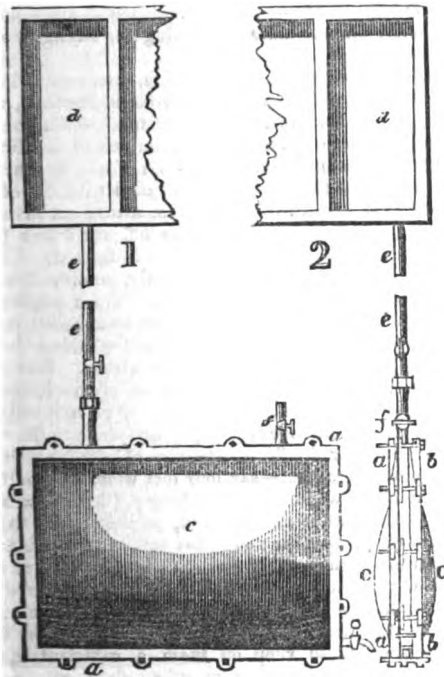
M. Seguin, a French chemist, investigated the process of tanning with great assiduity, and came to the conclusion that by condensing the tanning principle so as to accelerate its action, leather might be tanned in a less number of days than it usually takes of months. To effect this, his process is simple. He pours water upon the powdered tan, contained in an apparatus nearly similar to that made use of in saltpetre works. This water, by going through the tan, takes from it a portion of its tanning principle, and by successive filtrations dissolves every time an additional quantity of it, till at last the bark rather tends to deprive it of some than to give up more. Seguin succeeded in bringing these solutions to such a degree of strength that he could, according to his own statement, completely tan a calf-skin in twenty-four hours, and the strongest ox-hide in seven or eight days. These solutions containing a greater quantity of the tanning principle, impart (it is said) to the skin as much of it as it can absorb, so that it can then easily attain a complete saturation of the principle, and produce leather of a quality much superior to that of most countries famous for their leather.

When a patent for Seguin's method was taken out in this country, Mr. Nicholson stated, that from information acquired from the manufacturers, he found that they had previously been sufficiently acquainted with the powers of strong tanning infusions, and that it had even been proposed to employ them so as to abridge the process, but the leather thus produced was by no means equal

to that produced in the old way. The advantage of the slow and gradual process appears to be, that the whole substance of the skin is penetrated and equally changed; while in the more rapid method the external must be more acted on, and the texture probably more unequal. It appears also from Sir H. Davy's experiments, to combine with a larger quantity of the extractive matter contained in the astringent infusion; and hence, too, the advantage of the immersions in the weak liquors, as these contain more of this than the strong infusions. It must be confessed, however, that for any thing theory can discover, the common process appears to be unnecessarily protracted, and some advantage might probably be derived from adopting some of the manipulations of Seguin.

To accelerate the process of tanning, *warm* infusions of the tanning liquor, instead of cold, have been employed, and we are informed with some degree of success. With the same object in view, it has likewise been attempted to make leather by *forcing* the tanning liquor into the pores of the skin by mechanical pressure. The first of these attempts was made by Mr. Francis Gibbon Spillbury, of Walsall, in Staffordshire, who took out a patent for his process in 1834, which he thus describes in his specification:—"My invention consists in the introduction of the tan liquor, by means of mechanical force, into the pores or substance of the skin or hide, which I effect in the following manner:—The skin or hide being cleansed, and otherwise prepared in the usual ways for the action of the tan liquor, is to be carefully examined, and any holes that may be found are to be sewed, or otherwise secured, by means which are well known so as to prevent the liquor from running through; after which it is in a proper state to be exposed to the action of the tan liquor, in conjunction with mechanical pressure, which I effect in the following manner. I provide three frames, of similar shapes, made of wood, copper, or any other suitable material (I may mention that the use of iron for this purpose, unless covered with a coating of paint, should be avoided, as its effects would be to blacken the skin or hide), and furnished at the sides with ears or loops, for the reception of screw-bolts, the object being, by means of the outer frames, to press two skins or hides, one on each side, against the middle frame, and through an aperture in this middle frame to introduce the tan liquor under pressure into the space thus formed between the two hides, the effect of which will be to produce a continued filtration or percolation of the liquor; and in consequence of which, the tanning process rapidly takes place. The middle frame differs from the others in having two pipes let into it at the top, and a cock let into it at the bottom. One of the exterior frames being laid flat down, with its inner surface uppermost, a skin or hide, previously prepared as aforesaid, is laid or stretched over it; the middle frame is then laid on, taking care that the edges of the skin or hide shall be every where griped or nipped between the two frames; a second skin or hide, prepared as aforesaid, is then to be laid on the middle frame; and lastly, the other exterior frame is to be laid on, care being taken that the edges of the second skin or hide shall be every where griped or nipped between the middle frame and the last exterior frame. The frames and skins are then to be secured by means of screw bolts, entering into screwed holes, in the ears or loops. The frames are then to be raised upright; one of the pipes is to be secured to a pipe communicating with a cistern containing tan liquor; the other pipe is to be left open for the escape of air, and the cock at the bottom is to be closed. The cock of the pipe communicating with the cistern being opened, the liquor contained in the cistern will flow down, and will occupy the space between the two skins or hides, driving out the air. When the liquor has risen into the pipe for the escape of the air, shewing that the space is filled, its cock is to be closed; upon which the tan liquor between the skins or hides being subjected to hydrostatic pressure, by means of the communication with the cistern (and which may be produced, increased and varied by methods well known), will be forced through the pores or substance of the skins or hides, and will appear in the form of dew, or small drops, on their outward surface. The time required for completing the tanning will vary according to the density of the skins or hides, the strength of the tan liquor, the amount of the hydrostatic pressure, and other circumstances. When the skins or hides are found to be tanned, they are to be removed from

the frames, and their outer edges, as far as they were squeezed or nipped between the frames, must be pared off; the skins or hides are then to be dried, and prepared for market in the usual manner. It is not my intention to claim, under this patent, the exclusive use of the frames, screw bolts, pipes, or any article of apparatus herein mentioned; or the use of any particular kind of tan liquor, or any mode or process of preparing and of finishing the skins or hides, save and except the application of the machines or engines herein described or set forth, or any imitation of them, for the purpose of causing the tan liquor or liquors to pass, by filtration, or percolation, through skins or hides. The apparatus herein described for effecting this purpose is such as I have employed with success, and consider, upon the whole, to be best; but particular local situations, or other circumstances, may render it expedient to change the shape of the frames, or their vertical positions, for some other; or to enclose between the middle frames and either of the exterior ones, two or more skins or hides, instead of the single one, as above mentioned. *Fig. 1* is a front view, and *Fig. 2* is a side view. The same letters of reference indicate the same parts in each figure; *a a* is one of the exterior frames; *b b* is the other exterior frame; *e e* are two hides, secured between the exterior frames and the middle frame, by means of the screw bolts; *d* is the cistern containing the tan liquor; *e* is the pipe through which the tan liquor descends from the cistern into the space or cavity between the two hides, and which will vary in length according



to the amount of hydrostatic pressure intended to be given; *f* is the exit pipe, through which the air escapes when the liquor is running down through the pipe *e*; *g* is a cock for the purpose of discharging from between the skins."

Shortly after Mr. Spilsbury enrolled his specification, another person took out a patent for a slight deviation in the apparatus, but on the same principle



as Mr. Spilsbury's. Neither of these gentlemen, however, according to our information, have as yet succeeded in bringing their plans into practical operation, owing, we understand, to the curious circumstance, that the pressure has a tendency to drive the gelatin out of the skin, and to convert it into a very hard and inflexible material, not at all applicable to the ordinary uses of leather.

In 1827, Messrs. Knowlys and Duesbury obtained a patent for improvements in tanning, having a similar object in view, and, as it appears to us, with an arrangement better calculated to succeed. The skins were to be suspended vertically in a large air-tight vat, which, as well as the skins, were to be completely exhausted of air, previous to saturating them with the tan liquor, which the skins will, in consequence, more readily imbibe. A large aperture, or man-hole, is made in the top of the vat, for a workman to descend and hang up the skins, which are stretched from side to side upon hooks, at a regular distance apart, and kept in vertical and parallel positions by leaden weights, at their lower edges. This being done, a *weak* infusion of tan is admitted, until it covers the hides; the workman then closes the man-hole by the cover, which is rendered air-tight by a proper packing upon its rebated edges; the air is next exhausted by the air-pump as far as may be deemed necessary; in this state the vessel is to remain for a day or two, when the air may be re-admitted by a stop-cock, and the liquor pumped out through a pipe at the bottom of the vessel. The hides are then to remain to drain, and in contact with the air for a few hours, after which a second infusion of tan, stronger than that first used, is let in to cover the hides, and the process repeated as often as may be found necessary to completely tan the hides, increasing the strength of the liquors at every successive operation.

Our transatlantic brethren are not behind us in attempts to improve the old system of tanning. In the *Journal of the Franklin Institute*, we find the following specification of an American patent, granted to Osmond Cagwell, in 1831, which seems to be well deserving of the attention of the British tanner:—“The improvement consists in applying a solution of oak or other bark to hides or skins, in such manner, as that when the glutinous particles of the hide have absorbed and become mixed with the tanning or astringent principle, the other part of the solution (*viz.* the water) may pass off, and leave the hide free to receive more of the solution, and so on till it is tanned. The object is to expedite the process of tanning, and, consequently, to diminish the amount of capital necessary to be employed in the business. The *apparatus, and mode of application*, is as follows: Make a frame of timber, of a square form; the width to be made as great as the width of the hides, parts of hides, or skins, that are to be tanned; the height and length to suit convenience. Near the bottom, or ground of said frame, a light floor is to be formed of the length and breadth of the frame; said floor to incline to one side, so as to carry off the liquor after it has passed through the hide; the sides and ends to be raised from two to four inches above the floor, by fastening strips of plank on the inside of the frame; this will appear like a box,—say four feet wide, two inches high on one side, and four on the other, and twenty feet long; (these boxes may be fixed one above another, about twelve inches apart, to the top of the frame;) said boxes to be filled with *sawdust*, or any other soft porous substance that will not prevent the solution from running through the hide, and, at the same time, absorb and carry it off after it has passed through. On this surface (of *sawdust*) the hides, sides, or skins, (after having been prepared in the usual mode for tanning, except that the flesh is to be taken off clean,) are to be smoothly spread out, and, in order to keep on them a sufficient quantity of the solution, make sacks of coarse cotton or other cloth, an inch or more in diameter; fill them with the same material that the boxes are filled with, and place them around under the edges of the hides, which will raise said edges equal to the diameter of the sacks. After this is done, pour on the hides as much of the solution as the hollow surface which they will then present will hold, and continue to fill them up as it runs off through the pores of the hide for the space of from three to fifteen days (the time in

proportion to the thickness of the hide or skin), in which time they will be tanned, except the extreme parts or edges, which cannot be brought so fully under the process as the other parts of the hides; and in order *perfectly* to tan them it is necessary to lay them in vats after the common mode, for three or four weeks."

In 1832 Mr. William Drake, of Bedminster, near Bristol, specified a patent "for an improvement in tanning hides and skins," the novelty of which consists in applying the tanning liquor on one side only of the skin, and causing it to ooze through the skin to the other side, whence the aqueous portion of the liquor is abstracted by *evaporation*; the results of which process are stated to be, that the skins are more thoroughly and uniformly tanned, and that the operation is completed with *cold* liquor in ten days instead of ten months. The specification states that the skins are to undergo the usual primary process of *liming*; they are then to be immersed and well *handled* in a vessel containing *backward* (a weak solution of tan) until thoroughly saturated, which removes the lime and prepares them for a stronger impregnation. Thus prepared, the skins (excepting such as are intended for butts and middlings) are to be rounded; then two of them are to be laid face to face, and be carefully sewn together with waxed thread at their edges, so as to form a kind of bag impervious at the junction, leaving a small opening at the shoulder for the insertion of the neck of a funnel shaped vessel; but the patentee observes, it would be better to sew between the skins a collar adapted to receive the end of the funnel. As bags so formed would bulge out when filled, they are to be confined between two gridiron-like frames of parallel bars, adapted to compress the bag in such a manner as to produce internally a vertical stratum of liquid of about an inch in thickness between the two skins; and as the skins are thickest towards their middles, this variation is compensated for by cutting away a portion of the vertical wooden bars from a straight into a hollow curved line. The skins are suspended by loops to the bags, which traverse the upper horizontal bars of the frames, and the two frames are duly drawn together by four screw bolts passing through the extremities of the top and bottom bars. The funnel being inserted into the aperture between the skins, it is charged with strong tan liquor sufficient to distend the bag, and leave a surplus quantity to supply the loss by evaporation after the moisture has penetrated to the outside of the bags; a small gutter at the bottom of and between the frames receives whatever liquors may drop from the skins, and conducts it into a vessel, by which it is returned whenever necessary into the funnel reservoir above. To prevent the compression of the vertical bars from forming permanent indentations and ridges in the skins, the patentee directs that the bags be occasionally shifted a little laterally.

To facilitate the evaporation, and consequently the absorption of fresh solutions of tan, the operations are recommended to be conducted in chambers artificially warmed, and the liquor which oozes through the skin, and is received into the gutters, is directed to be conducted into vessels acting the part of refrigeratories, in order that *cold* liquor may always be supplied to the skins; (but how this liquor is to be preserved cold in a warm chamber, the specification does not explain). When the skins are sufficiently tanned, a stitch or two of the sewing at the bottom of the bag is opened, and the liquor is received into, and carried off by, the gutter underneath.

The claim to invention in this patent consists in the mode of accelerating the penetration of the tanning liquor by exposing the outer sides of the skins to evaporation. The process seems to be well calculated to economize time, but there is one defect in the arrangement for which we would suggest a remedy. The skins being laid vertically, the pressure of the column of liquid will cause a much more rapid absorption of the tan in the lower than in the upper part of the skins; and if no injury be sustained by the lower, by continuing the process until the upper is fully saturated with tan, there is, at the least, a loss of time. It is also probable that the liquor is stronger at the bottom than at the top of the bag. From both these causes, therefore, we should not expect that the leather produced would be uniform in its quality. To obviate these defects, we recommend the patentee to suspend his frames midway upon revolving axes,

and to fix at each end of his bag a charging vessel with a stop-cock, or some other simple contrivance to answer the same purpose: the bags may then be reversed at pleasure, swinging them round upon their axes into any desired position, and the lateral shifting between the bars will take place of itself. If there were only one charging vessel with a stop-cock to it, it would suffice; as by turning the frame half-way round it would serve for a discharging aperture.

Mr. Jacquemart, of Leicester Square, London, recently introduced, under a patent right, a process of tanning, which is stated to be especially applicable to the skins of small animals, such as hares, rabbits, cats, and sea-rats. Upon reading the specification, however, we did not find any thing essentially different from that which is well known, and in use, except that he adds a small quantity of *orpiment* to the other ingredients employed in tanning; 5 or 6 ounces are mentioned as a proper quantity for a hundred of the small skins. He commences the process by removing the hair from the skins; first taking off the long hair and afterwards the short; and to facilitate this operation, he steeps the skins in water slightly acidulated, (using sulphuric acid, in very small quantities,) or in the milk of lime; and in either of these the skins are suffered to remain till the matter which fixes the hair to the hide is decomposed. After the hair has been removed, the skins are to be again steeped in water containing a very small proportion of sulphuric acid, in order to raise or thicken them. The tanning is effected by steeping the skins in an infusion of bark, with the addition of the orpiment; the manipulations being the same as is practised in ordinary.

Of the numerous substances employed in tanning, oak bark is the chief in this country, not merely on account of its suitable properties, but from its comparatively low price, and the facility with which it may be obtained almost every where. In Russia, where the best of leather is made, the bark of the black willow is preferred, and next to that, the birch bark. Chesnut bark is now much esteemed for the purpose. A tanner at Bern-castle, on the Moselle, has lately employed the myrtle with great advantage; it is reported that by the use of it as a substitute for oak bark, better leather is made by it in much less time: a commission appointed at Treves, for the examination of leather so tanned, reported that they never before saw any article equal to it in quality. The *Recueil Industriel* has recently stated, that at Narbonne, the *marc* of grapes, after being distilled for the separation of the alcohol, had been found a most important substitute for oak bark in tanning. After the skins had been prepared in the usual way, they were placed in the pits containing the *marc* instead of bark; the skins were completely tanned in from thirty-five to forty days. The expected advantages are, shortening the process, reducing the cost, improved odour, and greater strength. But of all the substances of recent introduction, the extract from the mimosa, known in commerce by the terms *gum catechu*, and Japan earth, is the richest in tannin matter. This tree grows in vast abundance in New South Wales; where preparations have been made for making the extract on a great scale for the tanning process. The leather made from it is of a beautiful colour, and an excellent quality.

The experiments of Sir Humphrey Davy show, that 1 lb. of catechu is nearly equal to  $2\frac{1}{2}$  of galls, to 3 of sumach, to  $7\frac{1}{4}$  of the bark of the Leicester willow,  $8\frac{1}{2}$  of oak-bark, 11 of the bark of the Spanish chesnut, 18 of elm bark, and 21 of common willow bark, with respect to the tannin contained in them. He observes, too, that leather slowly tanned in weak infusions of bark, appears to be better in quality, being both softer and stronger than when tanned by strong infusions; and he ascribes this to the extractive matter they imbibe. This principle, therefore, affects the quality of the material employed in tanning; and galls, which contain a great deal of tannin, make a hard leather very liable to crack, from their deficiency of extractive matter.

The preparing and dressing of lambs, sheep, deer, goat, and other thin hides, closely resembles the method used with those of thicker or larger kind already mentioned, but it usually forms a distinct branch of business; and it is one that requires much practical skill and nicety of manipulation, to produce goods of the desired quality. The processes vary in many particulars, according to the

nature of the commodity. This branch of the leather manufacture supplies the immense demand of white and dyed leather, the (so called) Spanish and Morocco leather, of different colours and qualities, and a great variety of thin leather for different purposes. Of these, the white leather alone is not tanned, but is prepared by the process called *tawing*; but the coloured leather receives always a tanning, which is usually effected by sumach, independently of the other dyeing materials. The previous preparation of each, or that in which the skin is thoroughly cleansed, and reduced to the state of simple membrane, in which it is called *pelt*, is especially the same, whether for tawing or dyeing. The mode of performing these operations at Bermondsey, adjoining London, is as follows:—Lamb skins, are first soaked for a time in water, to cleanse them from the loose dirt and blood, then put upon the beam, (a half-cylinder of wood, covered with strong leather,) and scraped on the flesh side with the semicircular blunt knife with two handles, used for this operation; they are then hung up in considerable numbers, in a small close room heated by flues, where they remain to putrefy for a given time, during which a thick slime works up to the surface of the skin, and the wool is loosed, so that it readily comes off with a slight pull. Each skin is then returned to the beam, the wool taken off and preserved, and all the slime worked off with the knife, and the rough edges pared away. The skin is next put into a pit filled with lime water, and kept there from two to six weeks, according to the nature of the skin; this process has the effect of stopping the putrefaction of the skins, and renders them thicker and harder; after which it is again worked upon the beam, and much of its substance is pared down, and all inequalities smoothed with the knife. Much skill and judgment are required in these operations; on the one hand, not to endanger the substance of the skin by the putrefaction, and on the other hand, to work out every particle of the slime, the least of which, if retained, will prevent the skin from dressing well in the subsequent processes, and from taking the dye uniformly and well. The skin is again softened and freed from the lime, by being plunged into a vat of bran and water, and kept there for some weeks in a state of gentle fermentation, being occasionally returned to the beam. All the thickening produced by the lime is thus removed, and the skin in this highly purified state, is a thin extensible white membrane, called a *pelt*, which is a condition that adapts it to any subsequent operation, of tawing, or dyeing, oil-dressing, or shammying.

The method of bringing kid and goat skins to the state of pelt, is nearly the same as for lambs, except that the liming is used before the hair is taken off, the hair, being only employed by plasterers, is of little value; but the lamb's wool, which is more valuable, would be injured by the lime. Kid's skins, being of a closer texture than lambs', take a long time in tanning.

If the pelts are to be *tawed*, they are then put into a solution of alum and salt, in warm water, in the proportion of about three pounds of alum, and four pounds of salt to every 120 middle sized skins, and worked therein till they have absorbed a sufficient quantity. This again gives the skin a remarkable degree of thickness and toughness. The skins are then taken out, washed in water, and then again put into a vat of bran and water; and allowed to ferment for a time, till much of the alum and salt is got out, and the usual thickening produced by them is for the most part reduced. They are then taken to a lofty room, with a stove in the middle, and stretched on hooks, and kept there till fully dry. The skins are thus converted into a tough, flexible, and quite white leather; but to give them a glossy finish, and to take off the harshness of feel still remaining, they are again soaked in water, to extract more of the salt, and put into a large pail containing the yolks of eggs beat up with water. Here the skins are trodden for a long time, by which they so completely imbibe the substance of the eggs, that the liquor above them is rendered almost perfectly limpid; after which they are hung up in a loft to dry, and finish by glossing with a warm iron. The essential difference between tanning and tawing therefore, is, that in the former case the pelt is combined with tan or other vegetable matter, and in the latter with something that it imbibes from the alum and salt, probably alumine.

The Morocco leather (so termed from its being the same description of article

as was formerly imported from the kingdom of Morocco,) is distinguished into two kinds; one being made from deers' and goats' skins, which kind is by far the most durable and beautiful in appearance, and often called "*real Morocco*;" the other from sheep skins, which, from being only about one-third the price of the real, and being artfully made to imitate the other, by the dressing and finish, is most extensively used for book-binding, shoes, coverings to desks, furniture, and an infinite variety of purposes. The leather is thus made:—The skin, cleansed and worked in the way already described, is taken from the lime water, and the thickening thereby occasioned is brought down, not by bran liquor, as in tawing, but by a bath of dogs' or pigeons' dung diffused in water, where it remains until sufficiently suppled, and until the lime is quite got out, and it becomes a perfectly white clean pelt. If intended to be dyed red, or any other colour, the opposite edges of the skin are brought together and sewed up very tight, forming an irregular close bag, with the grain side of the skin outwards, as this side alone receives the dye; therefore, if there are any holes in the skin, they are also sewn up that the dye may not get inside the bag and dye both sides of the skin. The temperature of the bath should not be greater than the hand can bear, when the skin bags may be thrown in, which float upon the surface, the dyer working them about with a rod until they have imbibed the dye uniformly. The proper management of this process requires much skill and experience, some colours, particularly the compound, requiring two or more baths to obtain the required hue. The cochineal and Brazil reds are usually passed through a weak bath of saffron, which heightens the brilliancy of the colour, and gives an agreeable odour to the skins. After dyeing, the skins are tanned in a large vat containing a warm infusion of sumach, wherein they are kept for some hours, until they are sufficiently tanned. Those skins that are intended to be black, are first tanned in sumach, without any previous dyeing, as the sumach (or the gallic acid contained in it) acts as a mordant, to strike a black colour by the addition of a solution of iron, which is rubbed over them by a workman with a stiff brush.

The next processes are polishing and graining; they are performed either by hand or by machinery, and are technically called *finishing*. When performed by hand, the workman takes a skin and lays it before him upon an inclined mahogany table, the highest side of which is upon a level with the workman's middle, and the opposite side about a foot lower, in order that the weight of the body may assist in giving effect to the polisher; this is a ball of glass cut into polygonal surfaces, with which the workman, holding it between his fists, rubs the surface of the skin uniformly from the higher part of the table to the lower, the weight of the upper part of the body being the principal force applied: the skin being held by its edges overhanging the highest side of the table against which the man presses during the work. This polishing or glazing of the surface, (which greatly improves the appearance of the article,) being done, the graining is proceeded in. For this purpose the workman employs a ball of hard wood, usually box or lignum vitæ, around which, equatorially, are cut a series of equi-distant parallel grooves, producing thereby an alternating series of projecting parallel ridges; with these ridges the workman scores the skin all over in parallel lines, and when that is done he shifts the skin a little, so as to cross the first lines at a very acute angle, with his ridged ball; which he does uniformly over the skin, and thus produces a regularly corrugated surface.

In the application of machinery to the operations of polishing and graining, the principal difficulty to be overcome was to make the action accommodate itself to the varying thickness, hardness, and texture of the skin; for the necessary quantity of force to grain the firm parts of the skin, would, if applied to the tender parts, tear them; and unless the machine possessed a very sensible degree of flexibility, the prominent parts would get severely rubbed or struck, while the depressed parts would not get touched, or be but slightly acted upon. We shall annex a description of the earliest invention (about twenty-five years ago) for this purpose, which has been in use ever since.

*Hebert's Patent Leather-finishing Machine.*—This essentially consists of a very stiff circular frame or wheel, 8 feet in diameter, revolving horizontally on

vertical axis. On the under side of the periphery of this wheel are fixed, in suitable carriages, a series of circular polishers or grainers, according to the nature of the work to be done: the carriages being provided with proper means of adjusting the position of the rubbers with great exactness, and of readily fixing, unfixing, and changing them, according to circumstances. These rubbers, in their revolution, pass directly over a series of eight tables, circularly arranged underneath them. The upper surfaces of the tables are all brought to one true horizontal plane, parallel to the plane described by the under surfaces of the rubbers in their revolution. The skins to be polished or grained, are placed on these tables, one on each, and if they were all perfectly equal in thickness, tenacity, and texture, very little more would be required to make such a machine work; but as the skins differ in every possible degree in those qualities, the tables are mounted upon elastic bearings, and are further supported by a lever to each, at the end of which lever is a step or treadle, whereon the workman stands, either with both feet or with one foot only, that he may temper the force according to circumstances, or the nature of the work under operation; and when he steps entirely off the lever, the table falls below the level of the range of the rubbers, and therefore out of action. When the man is on the step, the surface of the table over which the rubbers act, approaches within the hundredth part of an inch of the plane described by the lower sides of the rubbers, so that when a skin is interposed, the thinnest parts are operated upon, and with a force as slight as the workman pleases, and the thick and tough parts with any greater pressure at the direction of the operator. For attaining and preserving a very true plane on that part of the table over which the polishers and grainers traverse, that portion of it is made of brass with adjusting screws underneath. The extremities of this metallic portion are gradually lowered a little from the true plane to prevent the rubbers striking the skin as they pass in rapid succession on to or off their work. A workman, who stands before each table, spreads the skin upon it, and keeps constantly shifting it after each rub it receives, till it has all been operated all over alike in parallel lines; he then turns the skin a little sideways, so that the grainers pass over the previous lines at an acute angle, as before mentioned in the hand work. The glazing and graining of leather may thus be performed in an equal, if not a superior manner to that of hand finishing, and at about one-tenth the cost. Owing to the ground rubbers not being properly chamfered off towards their edges, and to the irregular movements of the skin over the table, by unpractised operators, the skins were at first occasionally scored, showing in a disadvantageous manner the curved lines upon its surface. These defects were soon remedied by attention to the points mentioned, and the work afterwards executed was upon the whole of a superior description; for it will be readily conceived, that with so great a radius as 4 feet (the wheel being 8 feet in diameter), the curvilinear form of the lines so close together, and crossing each other, so as to form minute lozenge-shaped projections, would appear to be straight; and that if a scratch be made across a skin, it would equally mar its beauty, whether it were in a *straight* or a *curved* line. However, a gentleman of great talent (Mr. Joseph Ellis) subsequently conceived the idea of a finishing machine that would groove the skin in straight lines; and it was constructed with great accuracy and beauty of workmanship by Mr. Alexander Galloway, who joined Mr. Ellis in a patent for it. Whether this machine was ever brought to work to advantage the writer is not informed, or has no recollection, but it appears to him to be of a character deserving of notice in this place.

*Ellis's Machine.*—Instead of a great wheel revolving horizontally, like Hebert's, he employed a little wheel (about 30 inches diameter), which revolved vertically like a grindstone; on the outside edge of which were fixed, in suitable carriages, the glazers and grainers, provided with proper adjustments. The table on which the skins were laid was a hollow segment of a circle, of the same radius as that described by the rubbing surfaces of the glazers and grainers; thus the skins were impressed with right lines by a curvilinear motion, owing to their lying in a hollow curve. The specification of this invention, very ably and fully described, is given in the thirteenth volume of the *Repertory of Arts*, Second Series, to

which the reader is referred for the details; an inspection of the drawings in which inclines us to think the machine may have failed from two causes; *First*, the finisher incurs great risks from blows by the revolving tools as they successively descend into the hollow curve wherein the skin is operated upon. He has to look *down* this curve to see his work; and as the view is a very unfavourable one for examination, he might inadvertently put his head too near and get a fatal blow. If a guard were put up to prevent such an accident, it would be in the way, and obstruct light in a situation where more is wanted. *Second*, The necessity of extraordinarily accurate workmanship to make a perfect adjustment of the concave surface of the table, with the curve described by the revolving tools. A *third* objection will probably lie against the *direction* in which the table is brought into or goes out of action; it is made to slide in a horizontal and tangential line with the lower side of the circle described by the tools, consequently the lower extremity of the table comes into action first, which must subject this important part of the machine to shocks very unfavourable to the preservation of a perfectly true bearing. We submit that it would be better to make the table move in a radial line to the centre of the wheel, or at the least, in a tangent to a very small inner circle.

*Splitting of Hides and Skins.*—We have already noticed that after a sheep skin, or other raw hide, has been cleansed and purified from all extraneous matters, it undergoes a scraping and paring of its inner surface to give it a thinner or more uniform substance; by these processes the subsequent dyeing and tanning are greatly facilitated. This reduction of the substance was once entirely, and is still partially, executed by means of a knife in the hands of workmen, some of whom are so dexterous as to be able at every stroke of the knife to take off a shaving the whole breadth of the beam. The utmost exertion of ordinary skill was, however, insufficient to prevent the frequent recurrence of unlucky cuts, by which the value of the skin was considerably lessened, and the pieces sliced or scraped off were only applicable to the making of glue. But by the introduction of machinery to effect this operation, the skin is now divided throughout its entire substance into two parts of equal extent, one of which is subsequently converted into leather, and the other into parchment; at the same time the upper or hair side of the skin is thereby made smoother and of a more uniform thickness, which enhances its value. During the last forty years a variety of highly ingenious machines have been constructed for this curious and apparently difficult operation. It is now about twenty-seven years ago that we saw a beautiful machine for this purpose at work in the extensive manufactory of the Messrs. Bevington, near Bermondsey, the peculiar or essential features of which we shall be able to afford the reader an idea of in a few words.

*Bevington's Splitting Machine.*—In a stout A framing were mounted two horizontal rollers or cylinders, which were made to revolve in opposite directions by means of pinions at one of their extremities gearing into each other. The lower roller was solid and turned concentrically upon its axis; over this roller the skin in its wet state was spread out across its breadth, with its even side next to the roller, the uneven or flesh side being uppermost. To give an uniform pressure to the uneven side of the skin, a species of flexibility was conferred to the upper roller by compounding it of a series of circular metallic plates, like a roll of penny pieces, but which were about half an inch in thickness, and three inches in diameter; each plate had two holes, one in the centre, through which passed a fixed axis, smaller than the hole, in order that the plates might have a certain degree of play or eccentricity of motion; the other hole was about midway between the centre and the circumference, through which a rod passed freely, the extremities of which were so fixed to flanges at the extremity of the roller as to perform a planetary motion round the common centre of the plates; and as the rod passed through all the circular plates, they were all carried round with it, while the centre of motion of each individual plate, owing to the play given to them, were constantly being changed in proportion to the thickness of that part of the skin pressed against it, by the revolution of the lower inflexible roller. As the skin emerged from the bite between

the rollers, it came in contact with the straight edge of a very sharp knife; to which a constant sawing-like motion was communicated by the revolution of a crank. The circular plates, which were turned with great truth, were not pressed fast laterally, but kept slack and well oiled, their sides sliding freely against one another, so that each individual plate pressed simply by its own gravity, in order that however varied the thickness of the skin, the pressure should be uniform over the whole surface.

By this arrangement it will be observed, that the upper portion of the skin is the uneven one, and that the lower portion is the perfect skin, smooth, and uniform in all its parts. As a curiosity, and to show the capability of the machine, sheep-skins were sometimes split into three parts of equal area; the outside one being applicable to the preparation of several kinds of leather, the middle to the making of parchment, while that on the flesh side, from its inequality of thickness, and want of firmness, was only applicable to the making of glue.

*Stott's Splitting Machine.*—About the same period of time that we saw the machine at Messrs. Bevington's (which, we should have added, was said to be the invention of Lieut. Parr), another machine was brought under the notice of the Society of Arts, who rewarded the inventor, Benjamin Stott, of Bermondsey Street, with the sum of twenty guineas for the communication of the same. It is described with engravings in the twenty-fourth volume of the Society's *Transactions*, of which we subjoin the following brief account:—The skin is wrapped round a cast-iron barrel, having wooden ends, over which the sides of the skin are overlapped and made fast by pins stuck through them into the wood. There is also a longitudinal groove in the barrel for the insertion of a locking bar with points that holds down the ends of the skin underneath them. The barrel, with the skin so stretched upon it, is made to revolve by the agency of an attached cord passing over a pulley, and having a weight appended to the other end. The axis of the barrel rests upon two anti-friction rollers, which turn in a dip of brass fixed to the wooden frame of the machine; and the weight is only just sufficient to overcome the friction of these parts, and to bring up the skin against the edge of the knife as it cuts by the traversing motion of a frame to which it is screwed.

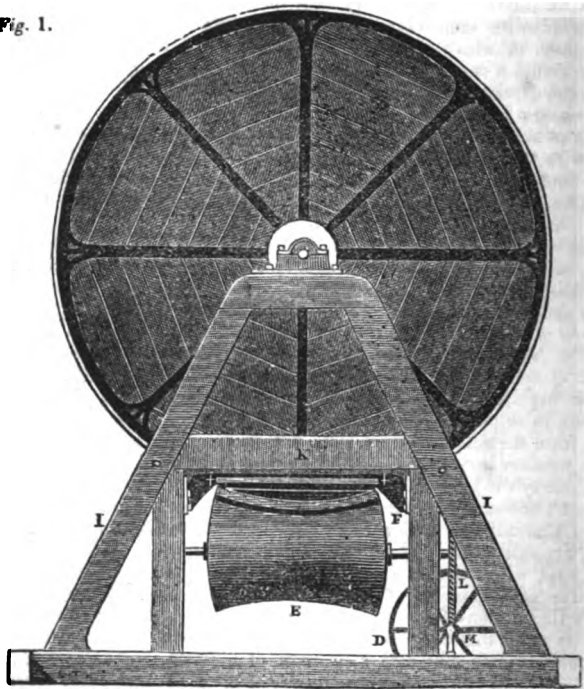
*Revere's Splitting Machine.*—By a reference to the eighteenth volume of the *Repertory of Arts*, Second Series, we find the specification of an English patent granted to Mr. Joseph Warren Revere, an American, "for a new and improved method of splitting hides and shaving leather," dated 1810, in which the patentee declares his method to "consist in the use of a *fixed or stationary* knife, and in so placing and confining it as to meet the hide or leather before it escapes from the action of the forcing cylinders; and also in the construction of, and the manner in which, a powerful action is obtained from the forcing cylinders, whereby the hide or leather, as it passes through, has not room to deviate, but must necessarily be forced and proceed right onward to the knife, and undergo the splitting and shaving intended. By this machine the hides or leather are split or divided into any thickness required, and with great expedition; and when divided or split, are left with smooth surfaces, and free from any marks of the knife." Thus far saith the record of the patentee; but whether the motion of the knife can be dispensed with, and yet produce good work, is a point that may still be questioned. We can conceive the possibility of its answering to split a skin, were it of uniform thickness; but it is otherwise, and the patentee has made no provision in his machine to accommodate that circumstance. He has a feeding roller set all over with points, which conducts the skin between a pair of *inflexible* rollers, "grooved or fluted longitudinally upon the surface of both of them;" and it is these that are said to force the skin so that it cannot deviate from passing on each side of the edge of the knife. But it seems to us evident that a sheep skin, varying as it does in its thickness, must be absolutely crushed in its thick parts before the thin parts can be compressed firm enough to be cut by a mere push, especially at that distance that a knife edge can approach a *fluted* roller; and as the *pressure* must be unequal where the surfaces of the skin are not parallel and the rollers are, it seems to follow that the skin would be cut into ridges in the direction of the motion of the skin.



We shall finish our account of this curious branch of art by the description of a novel and recently patented invention for the purpose, which has been furnished to us by that eminent draftsman, Mr. C. Davy, of Furnival's Inn, London.

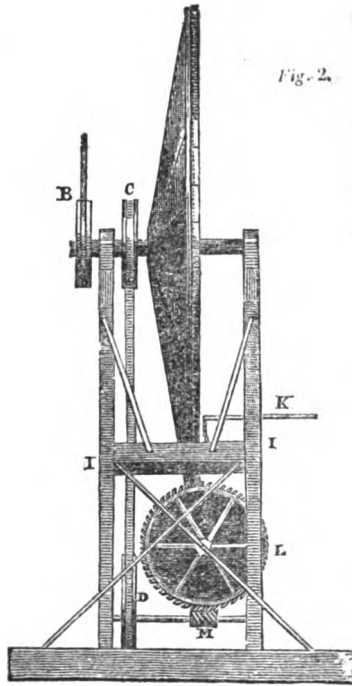
*Duxbury's Patent Skin Splitting Machine.*—Mr. Davy states that it has been found that the parallel sides of a cylinder are not adapted for the smooth extension of a skin upon them; and that the consequence of compressing it between such surfaces is to form little wrinkles, which the straight knife cuts through, and thereby produces holes. To obviate this defect, and also that of the ridges produced by the reciprocating action of the knife, a variety of machines has been projected, in which the cutters partook of a rotatory motion; but the mechanical difficulties attending the application of the principle have led to their abandonment. Mr. Duxbury has, however, by a novel position of the cutters, and a peculiar form of the bed over which the skin is laid, overcome all those difficulties, and the skins are cut by one continuous smooth slice over the whole surface. The machine, as shown in the subjoined engravings, *Figs. 1*

*Fig. 1.*



and 2, essentially consist of a great vertical wheel A, 17 feet in diameter, composed of wood, strengthened by iron arms; the axle of which turns in plummer blocks, upon a strong framing II. On the periphery of this wheel are fixed twenty-five thin plates of steel, ground to a fine edge, and so closely fitted as to form a complete circular knife, projecting a short distance *horizontally* from the side of the wheel. The skin to be split passes over the drum E, which instead of being straight sided longitudinally, has a curved concavity of the same radius as the curve described by the revolving knives, or continued

circular knife before mentioned; his drum is made of wood externally, fitted upon an iron frame, and turned to the true curve. A slit is cut longitudinally on the surface of the drum, wherein the edges of the skin are secured; and the skin is kept distended during the operation by means of a cast-iron frame F, called by the patentee the *governor*, and shown in the following figure (3), on a larger scale. The ends slide in guides in the upright posts of the framing, to which it may be adjusted and fixed; and it is provided at K with a lever and chain for raising or lowering it from its position, as may be required. The skin as it is split passes through the opening H, and thence on to the roller G, whereon it is wound. Motion is given to the machine by a band passing round the pulley B, which actuates the pulley C on the same axis; and this, by means of an endless band, turns the pulley D; on the axis of the latter is an endless screw M, which turns the wheel L on the axis of the drum; thus motion is communicated to the whole. In splitting small skins, several drums, such as that described, are arranged under the lower side of the great cutting wheel



The patentee also employs occasionally

Fig. 3.



a "governor" of a different kind, to compensate any irregularity that there may be in the surface of the drum; it consists, as shown in the annexed figure (4), of a series of pieces of metal hanging loosely on a bar, so that they may, simply by their gravity, press with a uniform force upon an irregular surface.

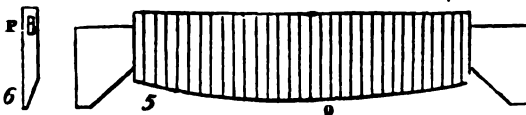


Fig. 4.

**Carrying Leather.**—This operation, which usually forms quite a distinct business, consists in a peculiar mode of dressing or preparing leather for boots, shoes, harness, and a variety of other things. The dressing of a calf skin for the upper-leathers of shoes, will give a general idea of the process. The ofal

parts, such as the head, tail, and shanks, being first taken off, (which is called rounding the skin,) it is soaked in a tub of water preparatory to shaving, which is performed upon a beam. The beam is a post fixed in an inclined position, and faced with lignum-vitæ, about 8 inches broad. The knife is a stout rectangular blade, about 12 inches long and 5 inches wide, with two edges; one end has a straight handle, and the other a cross handle in the direction of the plane of the blade. A coarse and a fine grit whet-stone are used to bring up the edge of the knife, which is afterwards turned to a "wire edge" by means of a steel instrument, which the workman constantly holds between his fingers. The mode of using the knife has already been noticed. In order to keep the substance of the skin equal, the man frequently examines it in the course of shaving in every part, by passing it double between his fingers; and when sufficiently reduced, he throws it a second time into a tub of cold water to be scoured and extended; for this purpose it is laid upon a stone table, to which the flesh side adheres, and is there worked with the edge of a small square stone fixed in a handle: pumice stone is sometimes used. With a brush the skin is cleansed from a substance called the *bloom*, which all leather, tanned with bark, is found to contain. After being thoroughly cleansed and distended while in its wet state, it is stuffed with a mixture of two parts cod oil, and one part tallow, called dubbing, which is applied to both sides of the skin, but chiefly on the flesh side. It is then hung up to dry, by which the moisture evaporates; and the oil, which cannot be dissipated by mere exposure, gradually takes the place of the moisture, and sinks deeply into the pores of the skin. The leather is next boarded or bruised, by a grooved piece of wood (like a crimping board) that is fastened to the hand by a strap; with this the skin is doubled and worked until made very flexible; it is next "whitened," that is, lightly shaved over again, by which the flesh side is well cleaned, and it is brought into a proper state to receive the colour used in waxing. Before it is waxed, however, it is boarded a second time, when it is in that state called finished russet, in which state it can be best preserved: therefore, until it is wanted for sale, the subsequent operations called waxing are left undone. The "colour," or blacking, is a composition of oil, lamp black, and tallow, which is well rubbed into the flesh side with a hard brush, great care being taken to keep the flesh side clean. A coat of strong size and tallow is then laid on with a soft brush; it is afterwards rubbed with a smoothing glass; and lastly, it receives the finishing gloss from a little thin size laid on with a sponge. After the first coat of size the skin is laid up to dry and incorporate, and a lump of hard tallow is rubbed lightly over the surface; the skin is thus completely finished for the consumer; and leather so dressed is found superior in point of appearance and durability to any other method. The carriers also blacken leather on the grain side, which is done by rubbing it with a solution of copperas, which, combining with the gallic acid of the tan, produces a black.

*Russia Leather* is prepared in Russia by a series of processes not essentially differing from our own. The tanning material is, however, seldom oak bark, the bark of the black willow being preferred; and where this cannot be obtained, birch bark is the next in request. Their dyed leather is usually red or black. For the red, the hide is first soaked in alum water, and then dyed with Brazil-wood. The black is given, as usual, with an iron liquor. The leather is then smeared with birch tar, which gives the peculiar smell so much prized (and which, when used for book-binding, has the valuable property of protecting the book from worms), and is finished by various other manipulations. The streaked or barred surface is given to the leather by a very heavy steel cylinder, wound round with wire, which makes the indentations.

*Saffian or Dyed Maroquin Leather*, of excellent quality, is extensively prepared at Astracan and other parts of Asiatic Russia. Only bucks' and goats' skins are used for this purpose, and the favourite colours are red and yellow. The general method of preparing the pelt is the same as in this country for the dyed Morocco leather; that is, by lime, dog's dung, and bran. Honey is also used after the branning. The honey is dissolved in warm water; and some of

this liquor is poured out on each skin, spread out on wooden trays till it has imbibed the whole of the honey; after which it is suffered to ferment about three days, then salted in a strong brine and hung up to dry. The skin is then ready to receive the dye, which, for red, is made with cochineal, and the *Salsola ericoides*, an alkaline plant, growing plentifully in the Tartarian salt deserts; and the colour is finished with alum. When dyed the skins are tanned with sumach. To the very finest reds a quantity of sorrel is used with the cochineal bath; and the subsequent tanning is given with galls instead of sumach, which renders the colour as durable as the leather itself. The roughness always observed on the surface of the skins, is given by a heavy kind of iron rake with blunt points. The yellow saffians are dyed with the berries of a species of *rhamnus* (the Avignon berry answers the same purpose), or with the flowers of the wild chamomile.

*Real Morocco Leather*, as prepared from goat skins at Fez and Tetuan, is thus described by M. Bruffonet in the *Bulletin des Sciences*. The skins are first cleansed, the hair taken off, limed, and reduced with bran, nearly in the same way already described for the English Morocco leather. After coming from the bran they are thrown into a second bath, made of white figs mixed with water, which is thereby rendered slimy and fermentable. In this bath the skins remain four or five days, when they are thoroughly salted with rock salt alone (and not with salt and alum), after which they are fit to receive the dye, which, for the red, is cochineal and alum; and for the yellow, pomegranate bark and alum. The skins are then tanned, dressed, supplied with a little oil, and dried.

*Shagreen*.—This singular and valuable leather is a manufacture almost peculiar to Astracan, where it is prepared by the Tartars and Armenians. For making shagreen, only horses' or asses' hides are taken, and it is only a small part from the crupper, along the back, that can be used for this purpose. This is cut off immediately above the tail, in a semicircular form, about 34 inches upon the crupper, and 28 along the back. These pieces are first soaked in water, till the hair is loose, and can be scraped off; and the skin, again soaked, is scraped or shaved so thin, as not to exceed a wetted hog's bladder in thickness, and till all the extraneous matter is got off, and only a clean membranous pelt remains. The piece is then stretched tight on a frame, and kept occasionally wetted, that no part may shrink unequally. The frames are then laid upon a floor, with the flesh sides of the skins undermost, and the grain sides are strewed over with the smooth, black, hard seeds of the alabuta, or goose-foot, (*Chinopodium album*), and a felt is then laid upon them, and the seeds trodden in deeply into the soft moist skin; the use of this is, to give the peculiar mottled or roughed surface, for which shagreen is distinguished. The frames, with the seeds still sticking to the skins, are then dried slowly in the shade, till the seeds will shake off without any violence, and the skin is left a hard, horny substance, with the grain side deeply indented. It is then laid on a solid block, covered with wool, and strongly rasped with two or three iron instruments (the particular forms of which it is unnecessary to describe), till the whole of the grain side is shaved, so that the impression of the seed is very slight and uniform. The skins are then softened, first with water and then with a warm alkaline lye, and are heaped warm and wet upon each other, by which means the parts indented by the impression regain much of their elasticity; and having lost none of their substance by paring, rise up fully to the level of the shaved places, and thus form the prominent grains, or the granular texture peculiar to shagreen: the skin is then salted and dyed. The beautiful green dye is given by soaking the inner or flesh side of the skin with a saturated solution of sal ammoniac, strewing it over with copper filings, rolling it up with the flesh side inwards, and pressing each skin with a considerable weight, for about 24 hours, in which time the sal-ammoniac dissolves enough of the copper to penetrate the skin with an agreeable sea-green colour: this is repeated a second time, to give the colour more body. Blue shagreen is dyed with indigo, dissolved in an impure soda, by means of lime and honey. Black shagreen is dyed with galls and vitriol. The skins are finished with oil or suet.

*Gumby's Patent Substitute for Leather*—1824.—This invention consists in the

application of an elastic coating and varnish to substances of a pliable nature, such as all kinds of cloth, whether cotton, linen, woollen, or felt. When the material is required to have flexibility, the composition is to be made of the following ingredients:—

Common glue size . . . . .	8 parts.
Boiled linseed oil . . . . .	4 "
Lamp black . . . . .	1 "
White lead, ground fine . . . . .	2 "
Pipe clay, ditto . . . . .	2 "

These are to be melted and well blended together over a fire. At first the size is to be melted, then the oil is to be added in small quantities at a time, next the lamp black, white lead, and pipe clay, during which it should be constantly stirred; the composition is then complete. The cloth being previously strained upon frames, the composition is spread on it evenly and smoothly with a pallet knife, working it well therewith into the interstices of the cloth, so that it shall be thoroughly saturated with the composition. The first coat is then to be dried, either in the air, or in a warm room, by hanging up the frames, care being taken that they be not exposed to much heat. When thoroughly dried and hard, a second coat may be laid on and dried in a similar way; also a third, a fourth, or a fifth, if required of great substance, which should all be spread on as smoothly, and every successive coat be hard before the next is laid on. This material, the patentee states, is chiefly intended for the manufacture of patten ties, and therefore he cuts it into strips previously to varnishing it, and passes them between polished metal rollers to give them a smooth even surface. Some drying linseed oil, or other suitable varnish is then brushed over the strips; mixing with the varnish any required colour to give the article the desired tint. The next operation is the cutting up the material into the usual sizes for patten ties, and finishing the same as usual under a screw-press with dies.

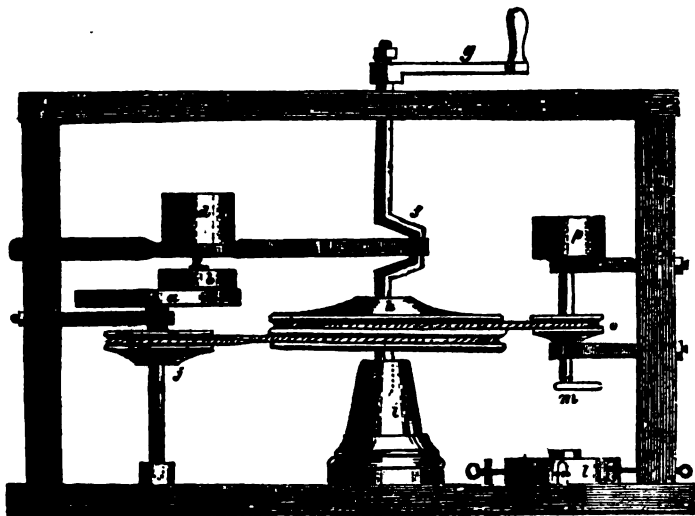
For coach tops, and other purposes where flexibility is not necessary, the quantities of the pipe clay, white lead, and size, may be increased, according to the nature and use of the article to be manufactured of it. For smoothening-down and polishing such large pieces of the cloth as will not pass through the roller press, the common method of rubbing with pumice stone, tripoli, &c. is adopted previous to varnishing.

*Hancock's Patent Substitute for Leather.*—Instead of using cloth, as in Mr. Gunby's patent just described, Mr. Hancock merely hackles or cards the fibres of flax, cotton, &c. by which they are drawn out into layers of a suitable thickness; they are then felted together in a trough of water, and afterward-pressed between cylindrical rollers. Over this fabric, liquid caoutchouc or Indian-rubber is to be spread uniformly by means of a spatula. When the caoutchouc has sufficiently solidified, it is to be again pressed, then receive another coat of the resin, and again pressed.

LEMONS, SALT OF, is the native salt of sorrel, the super-oxalate of potash, and is chiefly used to take the ink-spots out of linen. The effect is produced by the oxalic acid dissolving with facility the oxide of iron in the ink, on the combinations of which with the gallic acid the colour depends. It can be used without any risk of injuring the texture of the cloth.

LENS, in Optics, a piece of glass, or other transparent substance, having its two surfaces so formed that the rays of light have their direction changed by passing through it; so that they either converge, tending to a point beyond the lens; or diverge, as if they proceeded from a point before the lens; or become parallel, after converging or diverging. Some lenses are convex, that is, thicker in the middle than towards their circumferences; those that swell on both sides are called double convex lenses; some are concave, or thinner in the middle; some are plano-convex, or flat on one side and swelling on the other; some are plano-concave, or flat on one side and concave on the other; and lastly, some are concave on both sides. According to some opticians, the greatest diameter

of a lens is half an inch, if it exceed that thickness they do not call it a lens, but a lenticular glass. Lenses are made either by blowing or grinding. Blown lenses are small globules of glass melted in the flame of a lamp: ground lenses are reduced by grinding and polishing. A variety of simple apparatus is employed in the processes of grinding and polishing lenses, amongst which the following was recently introduced to the notice of the members of the London Mechanics' Institution, by Dr. Birkbeck, in one of his interesting lectures on improved mechanical inventions. *a* shows the edge of a circular lap or slab, used for grinding flat glasses upon; *b* a circular tool or block, upon the under surface of which the glasses to be ground are cemented; *c* is a reciprocating bar; *d* a box containing any weighty matter; *e* a long morticed aperture

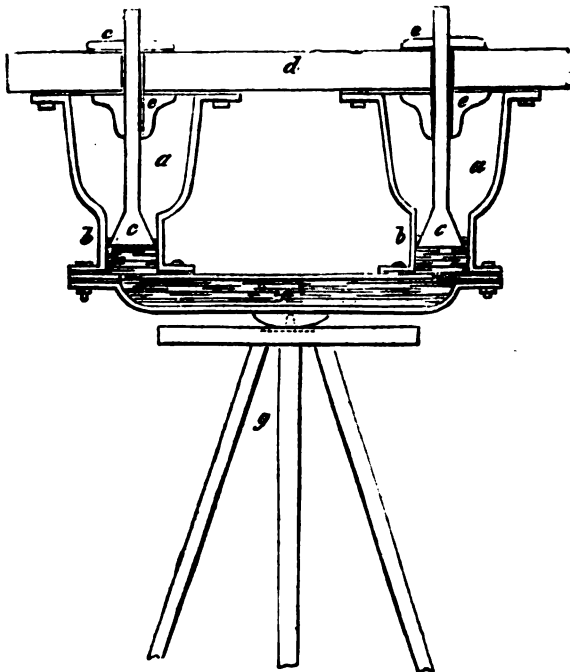


in the frame, through which the bar *c* freely works; *f* a crank; *g* a winch; *h* a double pulley wheel, the axis of which rests in the block *i*; *j* a single pulley wheel. Now on turning the crank by the winch *g*, the bar *c* gives to *b* an eccentric motion; the attrition of *b* on the surface of the lap *a* being increased or diminished at pleasure by increasing or diminishing the load in the box *d*. It should be noticed, that the cord which passes round the pulley *h* is crossed previous to its embracing the periphery of the pulley *i*, consequently a motion is given to the lap *a* the reverse of that given to *b*, which is considered to produce the best effect of grinding. The apparatus described is devoted to the producing of plane surfaces to optical glasses; but the apparatus on the other side of the machine, is at the same time, by similar arrangements, employed in grinding concave or convex surfaces. For this purpose a variety of laps and other tools, similar to those delineated in the margin, are so made as to fit on the bed *l*, which bed is adjustable by four equidistant screws. The pulley *o* is driven by another band as the pulley *h*, and the required pressure given by another loaded box *p*; the use of the lower tool *t* was not apparent to us (when we took our sketches), but we conjecture it is intended



to fix a diamond at the point, for cutting the glasses out of a true circular figure, by being screwed on at *m*. The several tools used are adapted for ready changing, that the operations may be performed with celerity. See *OPTICAL INSTRUMENTS*.

**LEVEL.** An instrument employed for obtaining a line or plane parallel to the plane of the horizon. One principal use of the level is to find the difference of elevation of two or more planes, for the purposes of conveying water, constructing roads, &c. from one place to another. Among the various contrivances employed for constructing instruments for finding the level, the following are some of the principal. The *water level*, the horizontal line by the surface of the fluid:—The most simple kind is nothing more than a long wooden trough, filled with water, such as is described by Vitruvius, under the name of the *chombates*. Another level of this kind consists of two cups, fitted to the ends of a straight cylindrical tube, of an inch in diameter, and three or four feet long, by which the water freely communicates from one cup to the other; the tube is movable on its stand by means of a ball and socket, and thus the surfaces of the water, when the cups are equally full, show the line of level. Two glass cylinders, of three or four inches in length, may be substituted instead of the cups, being fastened with wax or mastic to the ends of the tube: this machine should be filled with coloured water. A very simple quicksilver level, invented we believe by Mr. Parker, of Sweeney, is delineated in the annexed cut, which it is said is



much used in the north of England for irrigation, draining, &c. and does not cost as many shillings as the usual instrument employed costs of pounds. The two funnels or basins cast in iron from the same mould, their lower ends are conical cylindrical, and bored so as to be of exactly equal diameters; they

are screwed down by flanges to the tube *f*, which is flat at top, and through which the mercury flows. *cc* are two floats also exactly equal to each other in length, weight, and lower surface. A hole, one-eighth of an inch in diameter, is drilled on one side of the funnels for introducing the quicksilver, and afterwards closely stopped with a fine cork; *d* is a mahogany top to the instrument, to which the funnels, &c. are screwed; *ee* are collars or guides for the floats, made of lignum-vitæ, and to prevent the escape of the quicksilver; *g* is the stand and pivot on which it turns. Between all the junctures leather washers are introduced, to keep them tight.

In using this instrument, an observation is made on *the tops of the floats*, which, when they exactly coincide or project equally, shows the ground to be a true horizontal plane; on the contrary, when they differ in height, the ground is not level. This mode of *taking an observation* appears to us defective, as the most distant of two surfaces, when upon the same plane, cannot be distinctly seen. It would be better to have a circular hole through the tops of the floats, and to look at them from a fixed point on either side: when the two circles coincided, they would appear to the eye as only one of a true figure, and denote a true level; any deviation would be clearly denoted by the circles intersecting each other, and producing a curved figure, with two pointed ends, which would express exactly the extent of the alteration required. The simplicity and strength of the instrument permit of its being thrown down, and rolled about without sustaining injury, and any rough unlettered man may use it with effect. It may be had, we are informed, of Mr. Batt, Seedsman, 412, Strand, London.

In the *air level*, invented by M. Thevenot, the level is determined by means of an air-bubble, inclosed with some fluid in a glass tube, hermetically sealed at both its ends; the case or ruler in which the tube is fixed will be exactly level when the bubble remains at a marked point at the middle of the tube; the bubble being on either side of this mark shows the variation. The glass tube is sometimes enclosed in another of brass, the centre of which has a hole sufficiently large to observe the place of the bubble. The liquor employed should be such as will not readily freeze, rarefy, or condense, such as oil of tartar, aqua secunda, &c. The instrument last described has received many successive improvements, by the addition of sights and other apparatus. M. Huygens contrived a level, carrying a telescope instead of plain sights, which possesses some advantages above the common sort; and his invention has been improved upon in a variety of ways by the instrument makers. A machine of this kind, containing the principles both of the barometer and thermometer, was proposed by the late Dr. Desaguliers; but though in theory it seemed good, yet in practice it was found very inaccurate. (*Philosophical Transactions*, Vol. XXXIII. p. 65.) Amongst the various *spirit levels* that have been proposed, that contrived by Mr. Hadley deserves to be noticed; it is adapted to a quadrant for taking the meridian altitude at sea when the horizon is not visible. A description and drawing of this useful instrument may be seen in *Philosophical Transactions*, Vol. XXXVIII. The *reflecting level* is the next to be mentioned: it represents the object as reflected upon a long surface of water, in an inverted position, and was invented by Marriotti. Another kind, which we owe to Cassini, consists of a polished metal mirror, placed at a small distance before the object-glass of a telescope, suspended perpendicularly; this mirror being set at an angle of 45°, the perpendicular line of the telescope will become a horizontal line, that is, a line of level. The *plumb* or *pendulum level*, ascribed to Picard, shows the horizontal line by means of a line cutting the plummet line perpendicularly; it consists of two legs, joined together at right angles, with a telescopic sight, and other apparatus; the whole is fixed on a stand by means of a ball and socket. The *balance level* is an instrument suspended by a ring; and when in equilibrium, two sights, properly fitted to the instrument, will show the line of level. The *carpenter's, bricklayer's, or paviour's level*, consists of a long narrow board, to the middle of which is fixed, perpendicularly, another board, broader and shorter than the former, and having a line drawn through its middle, cutting the first mentioned board at right angles.



A plummet being suspended from the top of the upright piece shows that the base is horizontal when its line, and the line drawn from the point of suspension, exactly coincide. The *mason's level* is composed of three pieces, framed together in the form of an isosceles triangle. From the vertex of this a plummet is suspended, which, when it hangs directly over the mark in the centre of the base, indicates that the base is exactly in the line of level.

**LEVELLING.** The art or act of finding a line or plane parallel to the plane of the horizon. The uses to which this art applies, are the determining the height or depth of one place with respect to another; the laying out of grounds, regulating descents, conducting water, &c. It is necessary to premise that two or more places are, strictly speaking, on a level, when they are equally distant from the centre of the earth; and a line, of which all its constituent points are equally distant from that centre, is called *the line of true level*. But this line, consistently with the round form of the earth, must evidently be a curve, similar and parallel to the earth's circumference, and concentric with it. But the line of sight employed in such operations as are not on an extensive scale, differs from the line above described, being in effect a right line or tangent to the earth's circumference, and is called *the apparent line of level*. But this difference, as we have already remarked, need not be attended to in operations upon a confined scale, such as sinking of drains, paving of walks, or conveying water to short distances, &c.; but where the operations are required to be carried to a considerable extent, such as the construction of canals of many miles in length, the distinction between the true and apparent level must necessarily be attended to. The difference between the true and apparent level may be readily found from a property of the circle, demonstrated by Euclid, (*Elem.* Book III. Prob. 36.) In one mile this excess of the apparent above the true level will thus be found to be 7.9618, or almost eight inches. Hence, proportioning the excesses in altitude according to the square of the distances, the following table is obtained, showing the height of the apparent above the true level for every one hundred yards of distance on the one hand, and from a quarter of a mile to fourteen miles on the other.

Distance in Yards.	Difference of level in Inches.	Distance in Miles.	Difference of level in Feet and Inches
100	.026	$\frac{1}{4}$	0.0 $\frac{1}{2}$
200	.103	$\frac{1}{2}$	0.2
300	.231	$\frac{3}{4}$	0.4 $\frac{1}{2}$
400	.411	1	0.8
500	.643	2	2.8
600	.925	3	6.0
700	1.26	4	10.7
800	1.645	5	16.7
900	2.081	6	23.11
1000	2.570	7	32.6
1100	3.110	8	42.6
1200	3.701	9	53.9
1300	4.344	10	66.4
1400	5.038	11	80.3
1500	5.784	12	95.7
1600	6.580	13	112.2
1700	7.425	14	130.1

This table is adapted to several useful purposes. Thus, *first*, to find the height of the apparent level above the true at any distance. If the given distance is in the table, the correction of level is found on the same line with it; thus, at the distance of 1000 yards, the correction 2.57, or 2 $\frac{1}{2}$  inches nearly; and at the distance of 10 miles is 66 feet 4 inches. But if the exact distance is not

found in the table, then multiply the square of the distance in yards by 2.57, and then divide by 1,000,000, or cut off six places on the right for decimals, the rest are inches; or multiply the square of the distance in miles by 66 feet 4 inches, and divide by 100.

*Secondly.* To find the extent of the visible horizon, or how far an observer can see from any given height, on a horizontal plane, as at sea, suppose the eye of the observer, on the top of a ship's mast at sea, is the height of 130 feet above the water, he will then see about 14 miles round; or from the top of a cliff, by the sea-side, the height of which is 66 feet, a person may see to the distance of nearly 10 miles on the surface of the sea. Also when the top of a hill, or the light in a light-house, or such like, whose height is 130 feet, first comes into the view of an eye on board a ship, the table shows that the distance of the ship from it is 14 miles, if the eye is at the surface of the water; but if the height of the eye in the ship is 80 feet, then the distance will be increased by nearly 11 miles, making in all about 25 miles in distance.

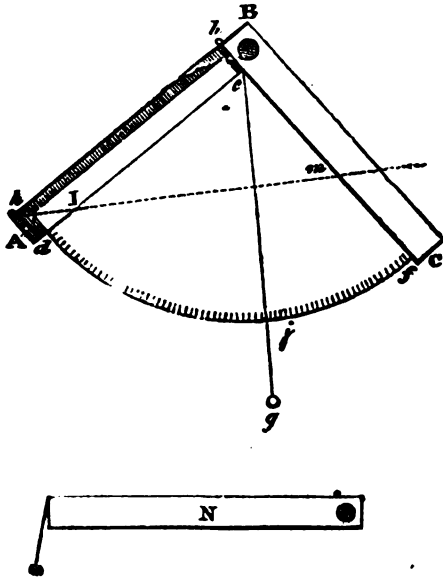
*Thirdly.* Suppose a spring on one side of a hill, and a house on an opposite hill, with a valley between them, that the spring seen from the house, appears by a levelling instrument on a level with the foundation of the house, which suppose is at a mile distance from it; then is the spring eight inches above the true level of the house; and this difference would be barely sufficient for the water to be brought in pipes from the spring to the house, the pipes being laid all the way in the ground.

*Fourthly.* If the height or distance exceed the limits of the table, then first, if the distance be given, divide it by 2, or by 3, or by 4, &c. till the quotient comes within the distances in the table; then take out the height answering to the quotient, and multiply it by the square of the divisor, that is, by 4 or 9, or 16, &c. for the height required. Thus if the top of a hill is just seen at the distance of 40 miles, then 40, divided by 4, gives 10, to which in the table answer 66½ feet, which being multiplied by 16, the square of 4 gives 1061½ feet for the height of the hill. But when the height is given, divide it by one of those square numbers, 4, 9, 16, 25, &c. till the quotient come within the limits of the table, and multiply the quotient by the square root of the divisor, that is, by 2, or 3, or 4, or 5, &c. for the distance sought; so when the top of the Peak of Teneriffe, said to be about 3 miles, or 15,840 feet high, just comes into view at sea, divide 15,840 by 225 or the square of 15, and the quotient is 70 nearly; to which in the table answers by proportion nearly 10½ miles; then multiply 10½ by 15, gives 154 miles, and ½ for the distance of the hill.

In what has been already stated, no regard has been paid to the effect of refraction in elevating the apparent places of objects. But as the operation of refraction incurvating the rays of light proceeding from objects near the horizon is considerable, it can by no means be neglected, when the difference between the true and apparent level is estimated at considerable distances. It is now ascertained, that for horizontal refractions the radius of curvature of the curve of refraction is about 7 times the radius of the earth; in consequence of which, the distance at which an object can be seen by refraction, is, to the distance at which it could be seen without refraction, nearly as 14 to 13; the refraction augmenting the distance at which an object can be seen by about a thirteenth of itself. By reason of this refraction too, it happens that it is necessary to diminish by ¼ of itself, the height of the apparent above the true level, as given in the preceding table of reductions. Thus, at 1000 yards, the true difference of level, when the allowance is made for the effect of refraction, will be 2570—367=2.203 inches. At two miles it would be 32—4½=27½ inches, and so on.

A very simple, portable, and easily constructed instrument for ascertaining the elevations of distant objects, was inserted in the *Register of Arts*; and as connected with the foregoing subject, we annex an engraving of it, (p. 82.) A B, B C, two equal pieces of wood turning on a screw at B; *e d f* a slip of parchment or paper pasted to the legs A B, B C, and folding between them when closed, after the similitude of a fan. Let the outer part *d j f* be made the quadrant of a

circle to radius  $e d$ , and let it be divided into 90 degrees;  $e j g$  a plumb line falling from the centre  $C$   $h h$ , two sights. If through  $h h$  the top of any object



be observed, the plumb-line  $e j g$  will cut off the number of degrees  $j f$ , contained by the angle of elevation. The proof is very evident. Let  $h I m$  be the horizontal line, to which  $e j g$  will always fall perpendicular; and since  $I e m$  is a right angled triangle, (*Euclid* vi. 8.)  $L e I m = L$  of elevation. The instrument may be closed as  $N$ , and carried in the pocket.

**LEVELLING STAVES, or poles,** are those employed in levelling, serving to carry the marks to be observed, and at the same time to measure the height of those marks from the ground. They usually consist of two mahogany staves, 10 feet long, in two parts, that slide upon one another to about  $5\frac{1}{2}$  feet, for the greater convenience of carriage. They are divided into 1000 equal parts, and numbered at every tenth division by 10, 20, 30, &c. up to 1000; and on one side the feet and inches are also sometimes marked. A vane slides up and down upon each set of these staves, which, by the pressure of springs, will remain stationary at any part. The vanes are about 10 inches long, and 4 inches broad; the breadth is first divided into three equal parts, the two extremes are painted white, the middle space divided again into three equal parts, which are less; the middle one of them is also painted white, and the two other parts black; and thus they are suited to all common distances. These vanes have each a brass wire across a small square hole in the centre which serve to point out the height correctly, by coinciding with the horizontal wire of the telescope of the level.

**LEVER.** One of the mechanic powers, or elements of machinery. It is usually defined an inflexible bar, movable round a fixed point of support, denominated the fulcrum. There are three kinds of levers, distinguished by the relative positions of the power, weight, and fulcrum. In levers of the first kind, the weight is applied at one end, the power that is to move it, at the other, and the fulcrum between them. In *Fig. 1*, on the next page, which represents a lever of this kind,  $W$  is the weight,  $P$  the power, and  $F$  the fulcrum;

while the distances  $FW$  and  $FP$  represent the arms of the lever.

*Fig. 2* is an example of a lever of the second kind, in which the fulcrum  $F$  is at one end, the power  $P$  at the other, and the weight  $W$  between them; the arms of the lever are represented by the same letters as before,  $FW$ , and  $FP$ . The third kind of lever, has its fulcrum  $F$  at one end, the weight  $W$  at the other, and the power  $P$  between them, as in *Fig. 3*.

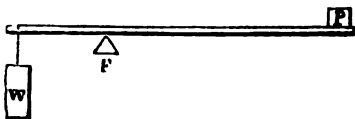
The relation between the power and weight is exceedingly simple. Thus, if the forces applied to a straight lever, are weights acting on it perpendicularly to the horizon, the proportion which the power bears to the weight, will be as the distance of the weight from the fulcrum is to the distance of the power from the same point, that is, the power and weight are inversely as their distances from the fulcrum. A general proposition, however, applicable alike to straight and bent levers, and to forces in any direction, may be thus stated. The

*power and resistance acting on a lever are inversely proportional to the perpendicular lines drawn from the fulcrum to the lines of direction in which the forces act.* To render the laws connected with this useful instrument as plain as possible, we shall consider the different cases separately.

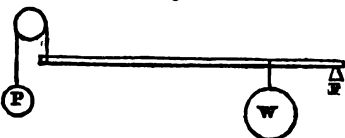
In *Fig. 4*,  $abc$  represents a lever whose fulcrum is at  $b$ , the power is to the weight as the shorter arm  $ab$  is to the longer  $bc$ . For if the lever be put into motion, the power will describe the arc  $cd$ , and the weight, the arc  $ae$ , which represent the velocity with which the bodies move. Now as these arcs are proportional to the length of the arms, if we multiply them by quantities which are inversely as the lengths of the arms, we shall produce equal quantities.

Now the lever will remain at rest when the momenta of its arms in opposite directions are equal, and this will occur, as we have shown, when the power and weight are inversely proportional to the lengths of the arms. If the arms are as 1 to 2, as in *Fig. 5*, a power of 50 lb. will counterbalance a resistance of 100 lb. The same will appear in a lever of the second and third kinds. In *Fig. 6*,

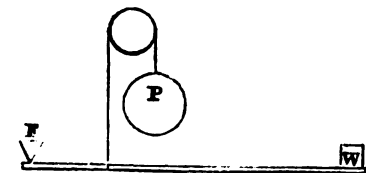
*Fig. 1.*



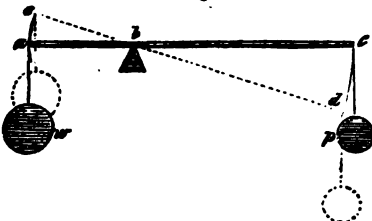
*Fig. 2.*



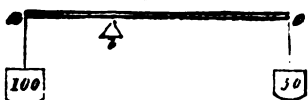
*Fig. 3.*



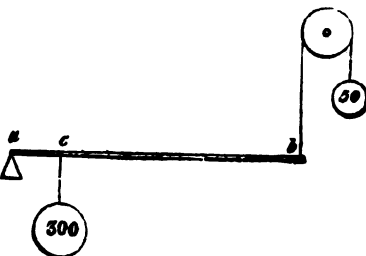
*Fig. 4.*



*Fig. 5.*



*Fig. 6.*



let the longer arm  $ab$  be 12 feet, and the shorter  $ac$ , 2 feet, then will the power be to the weight as 2 to 12; that is, a power of 50 will balance a weight of 300 lb. If the weight 300 be multiplied by the arm  $ac = 2$ , it will give a product of 600, the same as the 50 lb. multiplied by the arm  $ab = 12$ . This is constantly the case, that the power multiplied by its perpendicular distance from the fulcrum is equal to the weight multiplied by its distance from the same point. In levers of the third kind, in which the power is nearer to the fulcrum than the weight is, a loss of power is sustained, but this is amply compensated in the increased velocity that is obtained. In this, as in the other levers, is clearly evidenced that important truth in Mechanics, that in every case in which power is increased velocity must be diminished.

In levers of the first kind, the pressure on the fulcrum is equal to the sum of the forces acting upon it, and in the second and third, to the difference between them. Sometimes a number of forces may be applied at once,

as in *Fig. 7*. In this case, equilibrium will obtain, when the products formed by multiplying each weight by its distance from the fulcrum, are equal on each side.

When a series of levers are made to act on each other, they constitute a compound lever, as in *Fig. 8*. The power obtained by this lever is calculated

Fig. 7.

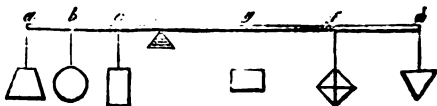
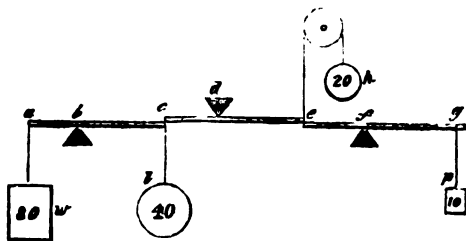


Fig. 8.



in the same way as the simple lever. Suppose each of the longer arms to be twice as long as the shorter ones, then a weight of 10 lb. suspended to  $fg$ , will counterbalance 20 lb. suspended to  $ef$ . If, instead of suspending a weight to the arm  $ef$ , it be made to act with its force of 20 lb. on the arm  $ed$ , it will support a resistance of 40 lb. at  $e$ , this 40 lb. acting on  $bc$  will sustain 80 lb. suspended to  $a$ . Hence it appears that in levers of this description, the power is to the weight or resistance, as the continued product of the shorter arms is to the continued product of the longer. The applications of the levers are exceedingly numerous. Levers of the first kind may be seen in the use of a poker in stirring the fire—in balances and steelyards—in scissors and snuffers, in which the rivet forms the fulcrum. A crow bar may be used either as a lever of the first or second kind, as in the accompanying sketches. The bent or angular lever may be seen in the action of a hammer in drawing a nail, *Fig. 10*. The handle of the hammer being the longer arm, and the distance from the nail to the point on which the hammer rests, the shorter arm. Levers of the second kind may be seen in a pair of bellows—in oars used in

Fig. 9.



Fig. 10.

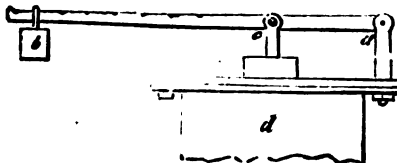


rowing boats, in the rudder of a ship, nutcrackers, &c. The safety-valves of steam engines are sometimes levers of the second kind. In Fig. 12, *b* is the power applied at different distances along the arm *a b*, the steam endeavouring to escape from the boiler is the resistance acting at *c*. It will easily be apprehended that the greater the distance between *a* and *b*, the greater will be the compressing force on the steam. Levers of the third kind may be seen in the human arm, a pair of tongs, shears for sheepsheering. Other examples might be given, but to those who have considered the instances already adduced, they will be sufficiently obvious.

Fig. 11.



Fig. 12



**LEVIGATION.** The art of reducing hard bodies to an impalpable powder; it is performed by pounding, rubbing, or grinding; or by a combination of these operations.

**LEVITY**, in Natural Philosophy, is that supposed property of a body by which it is said to be less weighty than another body, bulk for bulk; levity in this sense is the opposite to gravity. Thus cork, and all those substances that float on the surface of the water, have levity with respect to the water; or in other words, they are less heavy than that fluid.

**LEYDEN PHIAL**, in Electricity, is a glass phial or jar, coated within side and without with tin foil, or some other conducting substance, so as to be capable of receiving and retaining an electric charge for the purpose of experiments.

**LIGHT** is that principle or substance which renders objects perceptible to our sense of seeing. It is a subject, apparently but little understood, and upon which opinions are as much divided as any of the most abstruse subjects of philosophical inquiry. Some consider light as a fluid material; others regard it as a "vibration propagated from the luminous body through a subtle ethereal medium," &c. The limits and design of this work equally preclude the insertion of an extended article on the various hypothesis that have been promulgated on this interesting subject. See **OPTICS**.

**LIGHTER.** A large, open, flat-bottomed vessel, employed to unload or lighten a ship, and to convey the goods therefrom to their destination; especially when there is not sufficient depth of water for the ship to proceed farther.

**LIGHT-ROOM.** A small room in a ship of war, having double glazed windows, through which light is admitted into the powder magazine.

**LIGHTHOUSE.** A tower or other lofty building erected upon some headland or rock of the sea-coast, the upper part of which is brilliantly illuminated during the night-time to guide ships in their course, or warn them of contiguous danger. The fire-beacons or towers used for this purpose by the ancients were dedicated to the gods, and sacrifices were regularly offered up to implore safety to the mariners. As a knowledge of the sciences increased, they became establishments for the instruction of youth in navigation and astronomy. We have only very imperfect accounts of the construction of these buildings, but they appear to have consisted of a large tower of masonry, sometimes of a circular form, but more commonly square, finished on the top with a battlement, and containing various apartments. The fire was kept in a large and peculiar kind of chafing dish. To the early navigators the frequent recurrence of these buildings was absolutely needful, as they were destitute of the compass or any other guide, and were under the necessity of keeping near the shore, and were consequently in great danger from rocks and shoals. These

towers also formed a considerable part of the fortifications of the early ages. and before the invention of making distant signals, the watchmen were furnished with large sea-conchs, which they sounded from the battlements to warn the mariners, or to alarm the country in the case of an enemy. These fire-towers, which were once thickly scattered along the shores of the Mediterranean and the Red Seas, became, in time, scenes of the most horrid outrages; thus perverted from their original beneficial uses to the most baneful purposes, they were more dreaded than the dangers of the navigation; consequently they fell into disuse and decay, and gradually disappeared.

The most extraordinary of ancient structures of this kind was the Pharos of Alexandria, built on a small island at the mouth of the Nile, whence the word *pharos* has since been considered as synonymous with lighthouse. It was erected by Sostrates with such great magnificence, that it is said to have cost Ptolemy Philadelphus eight hundred talents of gold. It had several stories raised one above another, adorned with columns, ballustrades, and galleries, of the finest marble and workmanship. On the top a fire was kept constantly burning, which, according to Josephus, was seen at the distance of 300 stadia, or about 42 English miles. The famous Colossus of Rhodes served also as a pharos. The buildings which have in modern times replaced these ancient structures on the shores of the Mediterranean, &c., are far inferior to those of our own country; and as our limits will not allow of an extended view of the latter, we shall confine our account to the three most remarkable lighthouses on the British and Irish coasts; namely, that on the Eddystone, that on the Bell, and that on the South rocks.

The Eddystone lighthouse is situated at the entrance of Plymouth Sound, upon an extensive reef of rocks well known to mariners as the Eddy-stone (a name sufficiently significant of its dangers), lying at the distance of  $9\frac{1}{2}$  miles from the Ram-head or nearest point of land. The many fatal accidents which happened on these rocks, rendered it very desirable to erect a lighthouse on the spot, but the numerous and apparently insurmountable difficulties of such an undertaking prevented the attempt till the year 1696, when Mr. Winstanley undertook and accomplished this important object, though it was the work of four years. A violent storm, however, in 1703, destroyed every vestige of it, except some irons that were fastened in the rock. It was rebuilt in an improved form by John Rudyerd, a linen draper of Ludgate Hill, London. This building was of wood, in form the frustrum of a cone; it was formed of 71 upright beams, united together by being bolted to circular kirbs of wood placed within side, and upon which the floors were framed. Mr. Rudyerd made his building quite plain, without the least projection or ornament on which the water could act when dashing against it. The building was fitted up quite solid for 19 feet from the lowest point of the rock, and, excepting the well for the stair-case, was solid to the height of 37 feet. The solid was formed of three beds of moor-stone, with strong floorings of timber between each bed, to unite them with the external uprights. The whole erection, in addition to the weight of this stone, (which was about 280 tons,) was secured to the rock by 36 iron cramps. In the centre of the building a strong mast was erected, secured by 2 cramps to the rock at the bottom, and rising above the solid to the height of 48 feet, being united to the framing of each floor it passed through, and thus forming a central axis to strengthen the whole. This building had some repairs of its timbers in 1723, and again in 1744; but it showed itself, during the buffetings of the sea, for 49 years, to be of a very excellent construction. It was destroyed by fire in 1755. In 1756 Mr. Smeaton was employed to rebuild it. From the great uncertainty of the weather, every stone was so contrived that it was of itself in a condition to resist the wash of the sea, even when it was immediately laid. Each stone had one or two holes drilled through it before it left the work yard; and this hole being continued a few inches into the rock, or the stone beneath, a strong tree-nail was driven through it to pin it fast to its place: dovetails were also cut in the edges of each stone to connect them by oaken wedges, which secured the joinings whilst the mortar or cement was hardening; and as a further precaution against the latter being effected by the weather, all the

outsides of them were coated with plaster of Paris. The work went rapidly on in this manner, and the second course was nearly set in a few days; but a gale sprang up, which obliged the operators to quit the work, leaving a few stones of the second course lowered down into their places, and chained strongly to the rock; and one of the most exposed was secured by laying upon it five cwt. of lead. A storm came on, and it was afterwards found that this weight had been lifted by the waves, so that the stone beneath it had escaped and was lost, as were four others; from which circumstance the force of the sea on the rock may be conceived. The light-room was prepared in London; it consisted of eight cast-iron pillars for containing copper sash-frames for eighteen panes of glass each, with a cupola of wrought-iron and copper, terminating with a large gilded ball. The light consisted of twenty-four large tallow candles, suspended in a chandelier, and the first light was exhibited on the 16th of October, 1759, which has been continued ever since without any particular occurrence, or any accident produced by the many violent storms which have happened. In the year 1807 the chandeliers and the candles were removed, and in their place a reflector frame was fitted up with Argand burners and parabolic reflectors of silvered copper, to the great and essential improvement of the light. See *Smeaton's Narrative, &c. of the Eddystone Lighthouse*.

We now proceed to a brief account of the Bell-rock lighthouse, which, like its model, the Eddystone lighthouse, has figured in a thousand periodical publications, and will therefore not require the accompaniment of illustrations in our work. The Bell-rock is a dangerous reef, situated in the Firth of Forth, and the lighthouse upon it is of recent date. Various expedients have been resorted to at different times to warn the mariner of his approach to this rock, which is the more dangerous, as it is 12 feet below the surface at high-water. None of these, however, could be rendered durable; and though the necessity of a lighthouse was acknowledged on all hands, the difficulties and expenses attending such a work prevented the undertaking till the year 1806, when it was finally determined to erect a building of stone similar to that on the Eddystone rock. The work was begun in the year 1807 by erecting a building of timber as a temporary refuge for the workmen, which occupied the whole of the first season, as it was only for two or three hours each tide that the workmen could proceed. The winter was spent in preparing the stones ashore at Arbroath, and in the following summer four courses of stories were completed. In 1809 the solid part of the lighthouse was finished, being about 30 feet high. By September in the next year, the building was raised to its height of 100 feet, and a light was exhibited in February, 1811. The building is a circular tower, measuring 42 feet in diameter at the base, and 13 feet in diameter at the top. The ascent from the rock to the top of the solid, or lowest 30 feet, is accomplished by a trap ladder; but strangers who cannot well ascend by such paths, are hoisted up in a chair by means of a crane. The light-room is 88 feet above the medium level of the tide, yet the sprays of the sea occasionally lash against the glass, so that it becomes necessary in gales of wind to shut the whole of the dead-lights to windward. The light-room is of an octagonal figure, 12 feet across, and 15 feet in height. The light is from oil, with Argand burners placed in the focus of silver-plated reflectors. Machinery is used for tolling two large bells night and day during the continuance of foggy weather. Four light-keepers are appointed, three of whom are always at the lighthouse, and one, in his turn, is ashore at liberty. At Arbroath, a village on the coast about 12 miles distant from the Bell-rock, is a signal tower with an observatory, from which corresponding signals are kept up with the lighthouse.

The most remarkable lighthouse on the Irish coast is the Kilwarlin or South-rock lighthouse, lying off the coast of Downshire, and near the entrance of Loch Strangford, a station of great importance to the navigation of the Irish Channel. This lighthouse stands upon an extensive reef, lying about 3 miles from the shore. Part of the rock is at all times above the perpendicular rise of the tide, but the foundation of the lighthouse is only about 4 or 5 feet above low water of spring tides. It was the work of the late Mr. Rogers, engineer to the Board of Customs: it was founded in 1795, and measures 31 feet diameter at the base, 17 feet diameter at the top, and its height about 70 feet.



**LIGHTNING.** The explosion of the electric fluid in the atmosphere  
**LIGHTNING CONDUCTORS,** are pointed metallic rods fixed to the upper parts of buildings, to secure them from strokes of lightning. They were invented and proposed by Dr Franklin for this purpose, soon after the identity of electricity and lightning was ascertained; and they exhibit a very important and useful application of modern discoveries in this science. This ingenious philosopher having found that pointed bodies are better fitted for receiving and throwing off the electric fire than such as are terminated by blunt ends or flat surfaces, and that metals are the readiest and best conductors, soon discovered that lightning and electricity resembled each other in this and other distinguishing properties; he therefore recommended a pointed metallic rod to be raised some feet above the highest part of a building, and to be continued down into the ground, or the nearest water. The lightning, should it ever come within a certain distance of this rod or wire, would be attracted by it, and pass through it in preference to any other part of the building, and be conveyed into the earth or water, and there dissipated without doing any damage to the building. Many facts have occurred to prove the utility of this seemingly trifling apparatus. Some electricians have objected to the pointed termination of this conductor, preferring rather a blunt end, on the supposition that a point invites the electricity from the clouds, and attracts it a greater distance than a blunt conductor.

Although the application of lightning conductors to buildings on shore is always judicious, and their advantages very apparent, yet on ship-board, where the effects of lightning are most to be dreaded, the introduction of this means of defence has been slow and imperfect. The conductor hitherto employed at sea consists of long flexible chains or links of metal, about a quarter of an inch thick, sometimes of iron; those employed in the British navy are however of copper; they are usually packed in a box, and are intended to be set up from the mast-head to the sea when occasions require, so that, as observed by Mr. Linger in his excellent work on electricity, partly from inattention, and partly from prejudice, they frequently remain in the ship's hold during long and hazardous voyages quite unemployed; a remark, the truth of which is but too frequently verified in the damage so constantly happening at sea during lightning storms. The necessity of providing the best possible security against the effects of lightning on ship board has been long admitted; but continuous and fixed metallic rods have been deemed inapplicable to ships in consequence of their masts (the only parts to which they can be attached) being exposed to chances of injury, to motion in a variety of ways, to frequent elongation and contraction, and to the necessity which frequently arises for removing the higher masts altogether and placing them on deck. It was probably from these causes that the small flexible chains or links above mentioned were employed. Such conductors, however, will probably, on examination, be found less applicable than fixed continuous lines of metal, and, in every point of view, inefficient substitutes for them. Their great want of continuity, as well as their want of mass and surface, is very unfavourable to the transmission of severe explosions, the electric matter becoming sensible at the points of junction, as is evident by the sparks which appear upon them at the time of the discharge, so that in some instances they have been actually disunited; they are likewise objectionable as being liable to every species of injury incident to a ship's rigging, and much difficulty is experienced in keeping them in their position and unbroken, more especially during gales of wind, and at night, when the ship is under sail, and when it is perhaps required, as is already observed, to remove some portion of the higher masts. It has therefore been long considered desirable to apply, if possible, a permanent conductor, which should be always in its place and ready for action; and various attempts have been made, and suggestions advanced at different times, to apply fixed lightning conductors in ships, as the subject, from time to time, has demanded further consideration. To protect a ship effectually from damage by lightning, it is essential that the conductor be as continuous and as direct as possible, from the highest point to the sea, that it be permanently fixed in the masts throughout their whole

extent, so as to admit of the motion of one portion of the mast upon another; and in case of the removal of any part of the mast, together with the conductor attached to it, either from accident or design, the remaining portion should still be perfect and equivalent to transmit an electrical discharge. To fulfil these conditions, Mr. W. J. Harris, of the Plymouth Institution (to whose valuable paper on this subject, contained in a recent number of *Jameson's Edinburgh Journal*, we are indebted to the previous remarks), has recommended pieces of sheet-copper, from one-eighth to one-sixteenth of an inch thick, and about two feet long, and varying from six inches to one inch and a half in breadth, be inserted into the masts in two laminæ, one over the other; the butts or joints of the one being covered by the central portions of the other. The laminæ should be rivetted together at the butts, so as to form a long elastic continuous line; the whole conductor to be inserted under the edges of a neat groove, ploughed longitudinally in the aft side of the different masts, and secured in its position by wrought copper nails, so as to present a fair surface. The metallic line thus constructed will then pass downward from the copper spindle at the mast-head, along the aft sides of the royal mast and top-gallant mast, being connected in its course with the copper about the sheeve holes. A copper lining in the aft side of the cap, through which the top-mast slides, now takes up the connexion, and continues it over the cap to the aft side of the top-mast, and so on as before, to the step of the mast; here it meets a thick wide copper lining, turned round the step under the heel of the mast, and resting on a similar layer of copper fixed to the keelson. This last is connected with some of the keels on bolts, and with three perpendicular bolts of copper, of two inches diameter, which are driven into the main keel upon three transverse or horizontal bolts, brought into immediate contact with the copper expanded over the bottom. The laminæ of copper are turned over the respective mast heads, and secured about an inch or more down on the opposite side; the cap which corresponds is prepared in a somewhat similar way, the copper being continued from the lining in the aft part of the round hole over the cap, into the fore part of the square one, where it is turned down and secured as before, so that when the cap is in its place the contact is complete. In this way we have, under all circumstances, a continuous metallic line from the highest point to the sea, which will transmit the electric matter directly through the keel, being the line of least resistance. But since the main mast does not step on the keelson, it will be necessary to have a metallic communication at the step of the mast, with the perpendicular stanchion immediately under it, and so on to the keelson as before, or otherwise carry the conductor out at the sides of the vessel.

From what has been already observed, it will be apparent that in whatever position we suppose the sliding masts to be placed, whether in a state of elongation or contraction, still the line of conduction will remain perfect; for that part of the conductor which necessarily remains below the cap and top when the sliding masts are struck, is no longer in the line of action; consequently its influence need not be considered.

**LIME.** One of the primitive earths; and since the discovery by Sir H. Davy of its metallic base, which he denominated *calcium*, it is regarded by chemists as the *oxide of calcium*; that important substance commonly called lime being found to be a combination of calcium and oxygen. The nature of lime is proved by the phenomena of the combustion of calcium; the metal changing into the earth with the absorption of the oxygen gas. Lime is soluble in 450 parts of water, according to Sir H. Davy, and in 760 parts according to other chemists. The solution is called *lime water*, which is limpid, but has an acid taste, and turns vegetable blues to green. If lime water be allowed to stand, a scum called the *cream of lime* forms on its surface; and if this be removed another follows, till by this means the whole of the lime may be separated from the water. If the lime be not skimmed, the cream, after having acquired a certain thickness, precipitates and falls to the bottom. Pure lime, or calcareous earth, is never found native; but in combination with acids, particularly the carbonic, it exists in prodigious quantities. Marble, limestone, and chalk, are

all carbonates of lime; gypsum is a sulphate of lime. Berzelius attempted to determine the prime equivalent of calcium, from the proportion in which it combines with oxygen to form lime: on which Dr. Ure remarks that "his results can be regarded only as approximations, in consequence of the difficulties of the experiment. The prime equivalent of lime, or oxide of calcium, can be determined to rigid precision by my instrument for analyzing the carbonates. By this means I find that 100 parts of carbonate of lime consist of 43.60 of carbonic acid + 56.4 lime; whence the prime equivalent proportions are 2.75 acid + 3.562 base."

The operation called burning lime, consists in exposing marble, limestone, chalk, oyster shells, or any other carbonate of lime, for some time to a white heat, by which means the carbonic acid and water contained in these substances are expelled; and the earth which has the peculiar characters assigned to lime, is left behind in a mass which has little coherence, and is therefore easily reduced to powder. It is usually called quick-lime after calcination. Newly prepared it absorbs water with great avidity; it will absorb one-fourth of its weight of that fluid, and still remain perfectly dry. If a sufficient quantity of water be poured upon it, the lime falls into powder; some of the water is converted into vapour by the disengaged caloric of that part which unites with the lime; this is called the slacking of lime: if the quantity slacked be considerable, and performed in a dark place, light will be observed as well as heat.

The kilns for burning lime are of a great variety of forms, according to the kind of fuel used, and the manner in which they are to be wrought. Some persons affirm that the best form of a lime-kiln is that of an egg placed upon its narrow end, having part of its broader end struck off, and its sides somewhat compressed towards the lower extremity; the ground plate, or bottom of the kiln, being nearly an oval, with an eye or draft hole towards each end of it. It is supposed that two advantages are gained by this form over that of the spreading inverted cone (also much used). By the upper part of the kiln being contracted, the heat does not fly off so freely as it does in the spreading cone; on the contrary, it thereby receives a degree of reverberation which adds to its intensity. But the other, and more valuable effect is said to be this; when the cooled lime is drawn out at the bottom of the furnace, the ignited mass in the upper parts of it settles down freely and evenly into the central parts of the kiln. One of the best kilns that we are acquainted with is Heathorn's patent kiln, combined with the manufacture of coke, and described under the article IRON. The frustum of a cone is a form of kiln much used; and it may be some advantage to hollow or arch out the upper part, which is frequently done. In many parts of the south of England, lime is prepared from the calcination of chalk in kilns sunk in the earth, of the form of inverted cones, and lined with brick; the base of the cone is about 10 feet in diameter, and about 14 feet deep. It is calculated that a kiln of this kind will yield 150 bushels of lime in 24 hours. When the chalk is dry, about 5 bushels of it may be burned with 1 bushel of coal; but when damp, or in the winter, not more than 4 bushels by 1 bushel of coal. In Yorkshire, and some other places where coal is abundant, calcareous slate and limestones are burned in great pieces stratified with coal: in these cases the consumption of coal is equal to more than a third part of the lime produced. The waste of fuel in this process renders it very ineligible where coals are dear. The saving of fuel in the use of kilns is apparent from the previous accounts, but that saving, according to Mr. Rawson, may be considerably increased by inclosing the kiln at the top, and building a chimney over it; and it seems to follow that the higher that chimney is the better.

Some lime-burners prefer peat to coal for the fuel; but that preference has probably arisen from an injudicious management of coal. Mr. Dodson asserts peat to be more economical than coal; that coal, by its excessive heat, causes the limestone to run into solid lumps, which it never does with peat, as it keeps them in an open state and admits the air freely. That the process of burning goes on more slowly with coal, and does not produce half the quantity of lime. This inconsistency requires no comment; nevertheless peat is a very useful fuel for the purpose, and an excellent substitute for coal where the latter is scarcer

or denser. All kinds of lime exposed to the air recover nearly their original weight, except chalk lime, which, although long exposed, never recovers more than seven-eighths of its original weight. Some limestones, as Portland-stone, yield a very white lime; others, as chalk and roe-stone, a lime with a yellowish cast; the latter is best adapted for mixing with tarras, puzzolano, or Parker's cement, for buildings under water. It has long been said by lime-burners, that if limestone be imperfectly burned in the first instance, no further exposure of it to the fire will produce quick-lime. This assertion, which it was supposed was the offspring of ignorance, has been confirmed by M. Vicat, in a valuable treatise lately published by him on mortar and cements. Such lime, which is technically termed dead lime, does not slake with water, but upon being ground and made into a paste with water, differs from common mortar by setting under water.

*Whiting* is a fine carbonate of lime, made in some places by grinding soft chalk in a mill, separating the finer particles by washing them over in water, letting the water settle, and making up the sediment into loaves, which are exposed to the air to dry. There are numerous manufactories beside the river Thames, where whiting is thus prepared, the loaves being exposed on shelves in lofty sheds, which form, as it were, the vertical external walls of the buildings. In some places whiting is made from lime by slaking it with a little water, then grinding it in a mill with water, exposing the lime water to the air for some time to absorb the carbonic acid from the atmosphere, washing over the sediment, making it into loaves, and drying them. When made into small loaves it is called *Spanish white*; and if in small drops, *prepared chalk*; the *creta preparata* of the apothecaries. It is principally used as a white paint, either alone, or mixed with white lead; the inferior priced white lead has a large proportion of whiting mixed with it. Spanish white and prepared chalk are likewise extensively used to saturate acids in liquids in various chemical and manufacturing operations.

Lime with water form a paste of but little cohesion; for common mortar is mixed with rough sand to give it firmness; but the mortar for the outermost covering of in-door work, is mixed with hair to give it cohesion without lessening its capability of receiving a smooth surface. As lime absorbs carbonic acid gas as well as water from the atmosphere, it should be made into mortar before it has imbibed any considerable portion of it, otherwise it will be of little value. It is by the absorption of carbonic acid that mortar acquires hardness, its lime being slowly converted again into the state of limestone; but the hardness will not be perfect unless undisturbed from its commencement; when this circumstance is observed it soon acquires a moderate degree of hardness, but ages are probably required for it to attain its maximum. The silex or sand mixed with lime operates by hastening its crystallization. Lime, though infusible alone, promotes the fusion of all the other earths, and is extensively used in smelting iron ores; it serves as a flux to the alumine and silex which the ores of that metal contain.

Marl, which is of so much value in agriculture, consists of a mixture of lime and clay, and it is the calcareous part of its composition to which its value is owing; if the quantity of lime in it do not exceed 30 per cent. it is worthless. Every good soil contains a portion of carbonate of lime, which materially assists in retaining the moisture necessary to active vegetation. Limestone containing much magnesia is unfit to afford lime for the farmer's use; it may be known from good limestone by its being much longer in dissolving in acids. Lime is used by the soap manufacturer to render his soda caustic: it enters into the composition of glass, which it renders less liable to attract moisture, and less brittle than it would otherwise be. It is employed in the manufacture of glue to prevent its becoming flexible by the ready absorption of moisture. It is used by the tanner to facilitate the removal of the hair from skins. It is used by the sugar refiner to absorb the acid, which would prevent the sugar from crystallizing. A solution of lime is employed to cleanse feathers from their animal oil, and render them sweet and fit for use. Acids dissolve pure lime with effervescence, but heat is evolved during the solution. Water impregnated

with carbonic acid will dissolve a much larger quantity of it than before; and when deprived of this acid by exposure to the air, the lime it held in solution is precipitated; hence the formation of stalactites and incrustations found in caverns. The crystals of the solutions of lime in acids form what are called spars. The beautiful spar called fluor spar, or Derbyshire spar, is a fluato of lime, that is, a combination of lime and the fluoric acid. Combined with muriatic acid, large quantities of lime are held in solution by the waters of the ocean. Combined with sulphuric acid lime forms gypsum; gypsum, when calcined by a moderate heat, is called plaster of Paris. Combined with the oxymuriatic acid, or chlorine, it forms chloride of lime, the famous salt used in BLEACHING, (which see.) Combined with phosphoric acid, lime forms the solid parts of the bones of all animals. The shells of testaceous animals consist chiefly of carbonate of lime cemented by a small portion of animal glue; while those of crustaceous animals always contain more or less of phosphate of lime, which approximates them to the nature of bone.

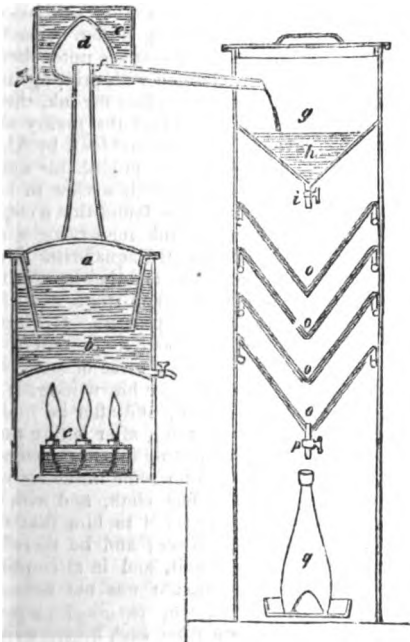
**LIMESTONE.** The native indurated carbonate of lime is usually distinguished by this name; but Professor Jamieson considers it as a genus of minerals, which he divides into four species; namely, Rhomb-spar, Dolomite, Limestone, and Arragonite; the third species, limestone, he divides into twelve sub-species, and these again into several kinds.

**LIMNING.** The art of painting in water colours, as practised by the ancients, in contradistinction to the more modern art of painting in oil. Before John Van Eyck (better known by the name of John of Bruges) found out the art of painting in oil, the painters all painted in water or fresco, on their walls, on wooden boards, and elsewhere. When they made use of boards, they usually glued a fine linen cloth over them, to prevent their opening; then laid on a ground of white; lastly, they mixed up their colours with water and size, or with water and yolks of eggs, well beaten with the branches of a fig-tree, the juice whereof thus mixed with the eggs; and with this mixture they painted their pictures. In limning, all pigments are suitable, except the white of lime, which is only used in fresco. The azure or ultramarine is always mixed with size or gum; and two layers of hot size are always applied to the boards, before the size colours are laid on; the colours are all ground in water, and in working diluted with size water. When the piece is finished, they go over it with the white of an egg well beaten; and then with varnish, if required.

**LINT.** The scrapings from the surface of old linen cloth, forming a very soft absorbent material, peculiarly adapted to the dressing of wounds; for which purpose it is chiefly used. This material is prepared for the use of surgeons, and as an article of commerce, in the following manner. Old linen, or such as has been worn for shirts, sheets, &c. is preferred to new cloth, on account of the great softness of the fibrous matter. Those pieces are selected which are without fracture, or nearly so, and that are 10 or 12 inches broad; these are washed, (or should be,) perfectly clean, and dried, and are then ready to be operated upon by the lint machine, which is generally worked by a woman. This machine consists of a steel knife blade with parallel sides, the edge of which is blunt or dull, but perfectly straight; this knife is fixed in a horizontal position in a frame, which is made to reciprocate up and down, by means of a treadle or pedal. When this pedal is pressed upon by the foot of the workwoman, it causes the blade to descend vertically with its edge across a board or little table, covered with smooth leather, whereon the linen is placed; and on taking the pressure off the pedal, the knife is lifted from the work by the agency of springs. The linen is rolled *very evenly* upon a cylindrical stick, with the web in the direction of the stick; and consequently with the warp threads of the cloth rolled round it. A few inches of the cloth being uncoiled, and a few threads of the web pulled off at the end, leaving as it were a fringe of the warp projecting, the roller is held steadily with both hands by the operator, who begins by placing the end of the cloth in such a position upon the work board, that when, by the pressure of the foot upon the pedal, the knife descends, its edge shall pass between the first and second thread of the web, and press across all the warp threads; whilst the latter is thus held down to the table,

the operator pulls back the stick towards her, through a space of from a quarter to half an inch; the weft thread is thereby pushed further along the warp threads, and from the latter is scraped the lint, by their being drawn under the edge of the knife. The foot being lifted from the pedal, the knife ascends, and the operator pushes the cloth forward again to take the next thread, which, by the pressure of the knife, and the pulling back of the cloth at the same instant, is moved along the threads of the warp after the first, and raising thereby more lint. In this manner the operation is conducted, thread after thread, (almost as quickly as a person could count them,) until all the cloth (or all the pieces of cloth sewn evenly together) upon the cylindrical stick is worked off; and thus is produced, when the work is dexterously performed, a continuous tender sheet of thick downy lint. Simple as this operation may appear, it requires considerable practice to obtain the necessary skill and adroitness to do the work well, and enable the operator to get a living by it; it is usually executed by very poor women, who earn only about ten shillings per week at the employment. The difficulty consists in making accurate movements by the hands with great quickness; for if a weft thread is crossed by the knife, the work is checked or spoiled instead of forwarded. The editor has never met with any published description of this operation, but he saw it performed about 20 years ago by a poor old woman, and this account is sketched out from recollection.

**LIQUEURS.** This name, adopted from the French, is given to a variety of odoriferous, fine flavoured, alcoholic liquors; the processes of preparing which have been given in various parts of this work; see EAU DE COLOGNE, EAU DE LUCA, &c. In this place we shall insert the description of a very convenient little



apparatus, and the process of working it, which we understand is much used at Paris, and elsewhere, for the purpose. At *a* is the boiler (containing the distilled spirits and flavouring ingredients) immersed in a water bath *b*, and heated

by a spirit lamp *c*, having several wicks. The still has a tall neck, surmounted by a head *d*, surrounded by cold water in the refrigeratory *e*. The vapour, as it is condensed, runs down the sides of the head, and is received in a circular channel, formed around the upper extremity of the neck, whence it flows down a pipe *f*, through the cold water cistern, into a recipient *g*, fixed above a series of funnel-shaped filterers. Previous to commencing the process of distillation the recipient *g* is provided with a sufficient quantity of syrup, (solution of white sugar,) to form the intended liqueur, over which the condensed spirit discharges itself. When all the spirit is come over, the distillation is stopped by extinguishing the lamp; the cock *i* is now opened, when the aromatic spirit and the syrup descend into the first of the filterers *o o o o*. These filterers are each composed of four distinct substances or layers; the lowest is of perforated metal, the next above fine flannel, over which is put two thicknesses of filtering paper. The spirit and the syrup become intimately blended in passing through these successive filterers, and the liquor is received in bottles underneath in a perfectly bright and clear state.

**LITHIA.** An alkali, recently discovered by M. Arfredson, a young chemist, employed in the laboratory of M. Berzelius. Sir H. Davy demonstrated by voltaic electricity that the basis of this alkali is a metal, to which the name of *lithium* has been given. For the mode of obtaining lithia, and an account of its properties, the reader is referred to *Ure's Dictionary of Chemistry*, as it has not yet been brought into use in the arts.

**LITHOGRAPHY.** The art of transferring from stone, writings or drawings made thereon; which is quite of modern invention. Unlike other kinds of printing, this is strictly chemical, and is in consequence called in Germany, *chemical printing*. A drawing is made on the stone, either with ink containing oleaginous matter; or with chalk, containing similar substances, but in a more concentrated and indurated state. The drawing is then washed over with water, which sinks into those portions of the stone that are untouched with the grease of the drawing. A cylindrical roller, charged with printing ink, is then passed all over the stone, and while the drawing receives the ink, the rest of the stone is preserved from it by the water on account of the greasy nature of the ink. This art is said to have been invented by mere accident, by Alois Senefelder, of Munich, who being an author, and too poor to publish his works, tried various plans, with copper-plates and compositions, with a view to becoming his own printer. In the course of his experiments, he found that a composition of soap, wax, and lamp-black, formed an excellent ink for writing with on plates; as, when dry, it became firm and hard, and resisted aquafortis. He wanted facility, however, in writing backwards on the plates; and that he might exercise this at less expense, he procured some pieces of Kilheim stone, as a cheap material, on which, after polishing their surfaces he might practise. Having been desired by his mother to take a list of some linen about to be sent to be washed, and having no paper at hand, he wrote it out on a piece of stone with his composition. When he was afterwards about to efface his writing, it occurred to him that impressions might be obtained from it; and after he had bit in the stone with aquafortis, diluted with ten parts of water, after letting the fluid stand five minutes over it, he proceeded to apply printing ink to the stone, for which purpose he first applied a printer's ball, but after some unsuccessful trials, he made use of a thin piece of wood covered with fine cloth, and with this he perfectly succeeded in taking impressions. It appeared to him that this new mode of printing was of very considerable importance; and he therefore, though with great difficulties, persevered in improving it, and in attempting its application to practical purposes. He soon found that it was not necessary to have the letters raised above the stone; but that the chemical properties which keep grease and water so effectually separate from each other, were quite sufficient for his purpose. He afterwards bestowed much labour and assiduity in constructing the proper press, and other apparatus for printing. The first essays to print for publication were some pieces of music executed in 1796; afterwards he attempted drawings and writings. He still however found great difficulty in writing backwards, and this led him to think of the process of transfer; and

the use of dry soap, which was found to leave permanent traces which would give impressions, naturally led to the mode of chalk drawings. In 1799, after having made many improvements, Senefelder obtained a patent privilege for the electorate of Bavaria. In 1803, he introduced his discovery into Vienna, where he obtained a similar grant for ten years. The invention spread, though slowly, into France and Italy, but it was not brought over to England until 1801, when M. André d'Offenbach, a merchant in London, succeeded in introducing it only to a very limited extent. While the war lasted, the employment of the lithographic art was chiefly confined to the quarter-master general's office at the Horse Guards, where it was used for printing the plans of battles, and maps of the seat of war. After the peace the art was revived, and there are now in England, as well as in all parts of the continent, numerous establishments, where it is practised with great excellence; and it is difficult to say at the present time, whether the German, French, or English artists, have obtained the pre-eminence. We shall now proceed to explain the several processes of the art.

*The Stones, and the manner in which they are prepared to receive the drawings.*—The stone most used in England is found at Corstan, near Bath: it is one of the white lias beds, but not of so fine a grain, nor so close in texture as the German stone, and therefore inferior; but it is good for transfers, and does tolerably well for ink drawings or writings. All calcareous stones may be used in lithography, because they imbibe grease and moisture; but a stone entirely calcareous does not answer well; there should be a mixture of alumina and silic. One of the most certain indications of lithographic properties, is the conchoidal fracture: all stones of this kind will be found good, if they are also hard, have the fineness of grain, and the homogeneity of texture that are necessary. It is however said that none have yet been found equal to those obtained from the quarries of Solenhofen, near Pappenheim in Bavaria, and that the lithographers of eminence in Paris use no other. In order to sustain the pressure used in taking impressions, a stone, 12 inches square, ought not to be less than  $1\frac{1}{2}$  inch thick, and this thickness should increase with the area of the stone. The stones are first sawn to a proper size, and are then ground smooth and level by rubbing two of them face to face, with water and sand. They must be very carefully examined with a straight edge, to ascertain that they are perfectly level in every direction. This applies only to the side which is afterwards to receive the drawing, as the natural division of the stone is sufficiently true for the back. When the stones have thus been ground perfectly level, they are well washed, to free them from any of the coarser grains of sand which may have been used in smoothing them. They are then placed on a board over a trough, and they are again rubbed face to face with sand and water, but with a sand of much finer texture than that previously used. The greatest care must be taken to have the sand sufficiently fine; and for this purpose it must be sifted through a small close sieve, as a single grain of sand of a coarser texture than the rest will scratch the stone, and these scratches will afterwards appear in the impression taken from the stone. When the stones have been rendered sufficiently fine, and their grain sufficiently smooth, they must then be carefully washed and afterwards wiped dry with a clean soft cloth. This is the plan adopted to prepare the stones for chalk drawings, but to prepare them for ink drawings or writings, the following method is the best:—After the process just described has been completed, the stones are well washed to get rid of the sand, and they are then rubbed together, face to face, with powdered pumicestone and water. After they are made perfectly smooth, they are again washed and wiped dry, and are then separately polished with a large piece of pumicestone.

To clean the stones after they have been fully used, sand is strewed over the surface, which is sprinkled with water and rubbed with another stone, until the writing or drawing upon it has completely disappeared. It must then be washed in aquafortis, diluted with twenty times its bulk of water; and the stone is then prepared for a new drawing or writing, by being rubbed with fine sand or pumicestone as before. The longer drawings remain on stones the deeper the



ink or the chalk penetrates into their substance, and consequently the more of the stone must be ground away to remove them; this is also more necessary with ink drawings or writings than with chalk, owing to the greater fluidity and consequent penetrability of the former.

The substances used by the artist upon the stone, are either lithographic ink, or lithographic chalk. The former has been described under the article *INK*, (which see;) but—

*The Ink for making transfers* should be somewhat less burned, and therefore softer than that used for writing or drawing directly upon the stone.

*Lithographic chalk* should have all the qualities of a good drawing crayon. It should be even in texture, and carry a good point. The following proportions are recommended: 1½ oz. of common soap, 2 oz. tallow, 2½ oz. virgin wax, 1 oz. shell-lac. The rest of the process is the same as in making the ink. Less black should be mixed with the chalk than with the ink, its only use being to colour the drawing, that the artist may see the lines he traces. When the whole is well mixed, it should be poured into a mould and very strongly pressed, to expel any air that may collect in bubbles, which would render it spongy.

*Mode of drawing.*—Previous to drawing or writing, the stone must be well wiped with a clean, dry cloth. The ink is rubbed with water, like Indian ink, and is almost wholly used on the polished stone. The chalk is used only upon the grained stone; the polished surface of the other would not hold it. In drawing with ink, a gradation of tints is obtained either by varying the thickness of the lines, or their distances from one another, as in engraving. The ink lines on polished stones, being solid and unbroken throughout, receive the printing all over; and if the lines be drawn as fine and as uniform as they are usually on copper, the print from them will be in no respect inferior; but it requires a greater degree of skill to execute as well upon stone as is usually done upon copper or steel.

In using chalk, the grained stone should be very carefully dusted, and the utmost attention be paid to prevent any lodgment of the smallest particle of grease upon the surface; personal cleanliness is therefore absolutely necessary to the perfection of his work, especially in chalk drawings. The chalk is used upon the stone precisely in the same manner as crayon upon paper; but it is of essential advantage in lithography to finish the required strength of tint *at once*, instead of going over the work a second time, the stone being impaired in its ability to receive the second lining clearly, by the absorption of the first. Some practice is requisite to use the chalk cleverly, as there has been no chalk hitherto made that will keep so good a point as is desirable. There is likewise some difficulty experienced in obtaining the finer tints sound in the impression; and in order to obtain the lighter tints properly, it will be necessary to put the chalk in a rest, as the metal port crayon is too heavy to draw upon the stone. The editor, who sometimes practises, is in the habit, before he commences his subject, of pointing 20 or 30 pieces of chalk, stuck in quill holders, and placing them beside the stone in a little box, taking them up successively as the points become worn off, so as to avoid, if possible, the cutting off chalk during the work, which endangers the soiling of the stone. When a very sharp and delicate line is required, he sharpens the point of the chalk upon paper. By pushing it forward in an inclined position, and twirling it round at the same time between the fore-finger and thumb. As the chalk softens by the warmth of the hand, it is quite necessary to have several pieces, to be able to change them. Some artists cut their chalk into the wedge form, as being stronger. Those portions that break off in drawing should be carefully taken off the stone by a camel's hair brush.

*Preparation of the stone for printing.*—The drawing being finished on the stone, it is sent to the lithographic printer, on whose knowledge of his art depends the success of the impressions. The first process is to *etch* the drawing as it is called. This is done by placing the stone obliquely on one edge, over a trough, and pouring over it very dilute nitric acid. It is poured on the upper part of the stone, and runs down all over the surface. The stone is then turned, and placed on the opposite edge, and the etching water being collected

from the trough, is again poured over it, in the same manner. The degree of strength, which is usually about one per cent. of acid, should be such as to produce a very slight effervescence; and it is desirable to pass the etching water two or three times over the darkest parts of the drawing, as they require more etching than the lighter tints. Experience alone can, however, guide the lithographer in this department of the art, as different stones, and different compositions of chalk, will be differently acted upon by the acid; and chalk drawings require a weaker acid than the ink. The stone is next to be carefully washed, by pouring clean rain water over it, and afterwards with gum water; and when not too wet, the roller charged with printing ink is rolled over it in both directions—sideways, and from top to bottom—till the drawing takes the ink. It is then well covered over with a solution of gum Arabic in water, of about the consistency of oil. This is allowed to dry, and preserves the drawing from any alteration, as the lines cannot spread, in consequence of the pores of the stone being filled with the gum. After the etching, it is *desirable* to leave the stone for a day, and not more than a week, before it is printed from. The effect of the etching is first to take away the alkali mixed with the chalk or ink, which would make the drawing liable to be affected by the water; and secondly, to make the stone refuse more decidedly to take any grease. The gum assists in this latter purpose, and is quite essential to the perfect preparation of the surface of the stone.

*Printing.*—When the intention is to print from the stone, it is placed upon the platten or bed of the press, and a proper sized scraper is adjusted to the surface of the stone. Rain water is then sprinkled over the gum on the stone, which, being dissolved gradually, and a wet sponge passed lightly over all, the printer works the ink, which is on the colour table placed beside him, with the roller, in all directions, until it is equally and thinly spread on the roller. The roller is then passed over the whole stone, care being taken that the whole drawing receives a due portion of ink; and this must be done, by giving the roller an equal motion and pressure, which will of course require to be increased, if the drawing does not receive the ink readily. When the drawing is first used, it will not receive the ink so readily as it will afterwards; and it is frequently necessary to wet the stone, and roll it several times, before it will take the ink easily. After this takes place, care must be taken not to wet the stone too much; the dampness should not be more than is necessary to prevent the ink adhering to the stone where there is no drawing. After the drawing is thus rolled on, the sheet of paper is placed on the stone, and the impression taken. Upon taking the paper off the stone, the latter appears to be quite dry, owing to the paper having absorbed the moisture on the surface; it must therefore be wetted with a sponge, and again rolled with ink, the roller having been well worked on the colour table before being applied. During the printing, some gum must always remain on the stone, although it will not be visible, otherwise the ink will be received on the stone as well as on the drawing, by which the latter would be spoiled; so that if by too much wetting, or by rubbing too hard with the sponge, the gum is entirely removed, some fresh gum water must be laid on. If the stone has in the first instance been laid by with too small a quantity of gum, and the ink stains the stone on being first applied to it, gum water must be used to damp the stone, instead of pure water. Sometimes, however, this may arise from the printing ink being too thin, as will afterwards appear. If some spots on the stone take the printing ink, notwithstanding the above precautions, some strong acid must be applied to them with a brush, and after this is washed off, a little gum water is dropped in the place. A steel point is here frequently necessary to take off the spots of ink. The edges of the stone are very apt to get soiled, and generally require to be washed with an old sponge after rolling in; they must also frequently have an application of acid and gum, and sometimes must be rubbed with pumice-stone. If an ink is too thin, and formed of a varnish not sufficiently burned, it will soil the stone, notwithstanding the proper precautions are taken of wetting the stone, and preparing it properly with acid and gum; and if, on the other hand, the ink is too thick, it will tear the lighter tints of the chalk from the

stone, and thus destroy the drawing. The consideration of these circumstances leads at once to the—

*Principles of the Printing.*—The accidents just mentioned arise at the extreme points of the scale at which the printing inks can be used, for it is evident that the only inks that can be used are those which are between these points: that is, thicker than that which soils the stone, and, at the same time, thinner than that which takes up the drawing. Lithographers are sometimes unable to print in very hot weather, the reason of which may be deduced from the foregoing. Any increase of temperature will diminish the consistency of the printing ink; the stone will therefore soil with an ink which could be safely used at a lower temperature; hence a stiffer ink must be used. Now, if the temperature should increase so much that the stone will soil with any ink at all less thick than that which will take up the drawing, it is evident that the printing must cease till a cooler temperature can be obtained; for as the drawing chalk is effected equally with the printing ink, the same ink will tear up the drawing at the different degrees of temperature. This, though it sometimes occurs, is a rare case; but it shows that it is desirable to draw with a chalk or ink of less fatness in summer than in winter; and also, that if the printing room is in winter artificially heated, pains should be taken to regulate the heat as equally as possible.

*Other Difficulties in Printing, not referable to the foregoing general Principle.*—If the pressure of the scraper be too weak, the ink will not be given off to the paper in the impression, although the drawing has been properly charged with it. Defects will also appear from the scraper being notched, or not correctly adjusted, or from any unevenness in the leather or paper. After printing a considerable number of impressions, it sometimes happens that the drawing takes the ink in dark spots in different parts. This arises from the printing ink becoming too strongly united with the chalk or ink of the drawing, and if the printing be continued, the drawing will be spoiled. The reason of this is easily ascertained. The printing ink readily unites with the drawing, and being of a thinner consistency, it will, by repeated applications, accumulate on the lines of the drawing, soften them, and make them spread. In this case, it is necessary to stop the printing, and let the stone rest for a day or two, for the drawing to recover its proper degree of hardness. If the drawing should run smutty from any of the causes before enumerated, the following—

*Mixture for cleaning the Drawing while printing* must be used.—Take equal parts of water, spirits of turpentine, and oil of olives, and shake them well together in a glass phial, until the mixture froths; wet the stone, and throw this froth upon it, and rub it gently with a soft sponge. The printing ink will be dissolved, and the whole drawing will also disappear, though, on a close examination, it can be distinguished in faint white lines. On rolling it again with printing ink, the drawing will gradually re-appear, as clear as at first.

*Bleached Paper unfit for Lithographic Printing.*—Accidents sometimes occur in the printing from the qualities of the paper. If the paper have been made from rags which have been bleached with oxy-muriatic acid, the drawing will be incurably spoiled after thirty impressions. Chinese paper has sometimes a strong taste of alum; this is so fatal, as sometimes to spoil the drawing after the first impression. When the stone is to be laid by after printing, in order that it may be used again at a future period, the drawing should be rolled in with a—

*Preserving Ink;* as the printing inks would, when dry, become so hard, that the drawings would not take fresh printing ink freely. The following is the composition of the printing ink:—Two parts of thick varnish of linseed oil, four parts of tallow, one part of Venetian turpentine, and one part of wax. These must be melted together, then four parts of lamp black, very carefully and gradually mixed with it, and it must be preserved for use in a close tin box.

*Autographic Ink,* or that which is suitable for transferring on to the stone the writings or drawings which have been executed on paper prepared

for that purpose, should possess the following properties. The ink ought to be mellow, and somewhat thicker than that used immediately on stone; so that when it is dry on the paper, it may still be sufficiently viscous to cause adherence to the stone by simple pressure. The following is the composition. Dry soap, and white wax free from tallow, each 100 drachms, mutton suet, 30 drachms, shellac and mastic, each 50 drachms, lamp black, 30 to 35 drachms; these materials are to be melted in the way described for lithographic ink. (See *INK, LITHOGRAPHIC.*)

*Autographic Paper.*—The operation by which a writing or drawing is transferred from paper to stone, not only affords the means of abridging labour, but also of producing the writings or drawings in the same directions in which they have been traced; whereas, when they are executed immediately on stone, they must be performed in a direction opposite to that which they are eventually to have. Thus it is necessary to draw those objects on the left, which, in the impression, are to be on the right hand. To acquire the art of reversing subjects when writing or drawing, is both difficult and tedious; while, by the aid of transparent, and of autographic paper, impressions may be readily obtained in the same direction as that in which the writing or the drawing has been made. In order to make a transfer on to stone of a writing, a drawing in lithographic ink, or in crayons, or an impression from a copper plate, it is necessary 1st, that the drawing or transcript should be on a thin and flexible substance, such as common paper; 2d, that it should be capable of being easily detached from this substance, and transferred entirely on to the stone, by means of pressure. But as the ink with which a drawing is traced penetrates the paper to a certain depth, and adheres to it with considerable tenacity, it would be difficult to detach them perfectly from each other, if, between the paper and the drawing, some substance was not interposed, which, by the portion of water which it is capable of imbibing, should so far lessen their adhesion to each other, that they may be completely separated in every point. It is to effect this that the paper is prepared, by covering it with a size, which may be written on with facility, and on which the finest lines may be traced without blotting the paper. Various means may be found of communicating this property to paper. The following preparation has always been found to succeed, and which, when the operation is performed with the necessary precautions, admits of the finest and most delicate lines being perfectly transferred, without leaving the faintest trace on the paper. For this purpose, it is necessary to take a strong, unsized paper, and to spread over it a size prepared of the following materials: starch, 120, gum arabic, 40, and alum, 21 drachms. A moderately thick paste is made with the starch, by means of heat; into this paste is thrown the gum Arabic and the alum, which have been previously dissolved in water, and in separate vessels. The whole is mixed well together, and it is applied warm to the sheets of paper, by means of a brush, or a large flat hair pencil. The paper may be coloured by adding to the size a decoction of French berries, in the proportion of ten drachms. After having dried this autographic paper, it is put into a press, to flatten the sheets, and they are made smooth by placing them, two at a time, on a stone, and passing them under the scraper of the lithographic press. If, on trying this paper, it is found to have a tendency to blot, this inconvenience may be remedied by rubbing it with finely-powdered sandarac. Annexed is another recipe, which will be found equally useful, and which has the advantage of being applicable to thin paper, which has been sized. It requires only that the paper be of a firm texture; namely, gum tragacanth, 4 drachms; glue, 4; Spanish white, 8; and starch, 4 drachms.

The tragacanth is put into a large quantity of water to dissolve, thirty-six hours before it is mixed with the other materials; the glue is to be melted over the fire in the usual manner. A paste is made with the starch; and after having, whilst warm, mixed these several ingredients, the Spanish white is to be added to them, and a layer of the sizing is to be spread over the paper, as already described, taking care to agitate the mixture with the brush to the bottom of the vessel, that the Spanish white may be equally distributed throughout the liquid. We will hereafter point out the manner in which it is

furnished at a quarter of their present actual value; in fact, all those which are done in lines, or those in which the shadows are boldly executed, are capable of re-producing good impressions by means of autography. The operation becomes extremely difficult when it is necessary to transfer fine line engravings; the lines of these are so delicate, and so near to each other, that they either do not take well on the stone, or are apt to be crushed and confounded together by the effect of the pressure. Much practice and address are necessary to obtain tolerable impressions; and this part of the art requires improvement. In the office of M. de Lasteyrie, they had succeeded in transferring to stone a small highly-finished engraving, which had been printed on common half-sized paper. After having dry-polished a stone very perfectly, it was warmed, rubbed with spirits of turpentine, and then the engraving was applied to it. This had, however, been previously dipped into water, then covered on the reverse side with turpentine, passed again through the water, so as to remove the superfluous turpentine, and then wiped with unsized paper. In this state the engraving, still damp with the turpentine, was applied to the stone and submitted to pressure, when it afforded very good impressions; the preparation not being applied until it had remained on the stone for twenty-four hours. The difficulties increase, of course, in proportion to the size of the engravings which it is desired to transfer to the stone. Attempts have been made to transfer old engravings; they have, however, succeeded but imperfectly. It would be rendering an essential service to the art to discover a mode of re-producing old engravings by means of autography; the undertaking presents difficulties, but from the attempts made, success does not seem improbable.

*Printing from two or more Stones with different Coloured Inks.*—This is managed by preparing a composition of two parts of wax, one of soap, and a little vermilion. Melt them in a saucepan, and cast them into sticks; this must be rubbed up with a little water to the thickness of cream, and applied to the surface of a polished stone. An impression is taken in the common way from a drawing, and applied to a stone prepared in this manner, and passed through the press, taking care to mark, by means of this impression, two points in the margin corresponding on each of the stones. The artist, having thus on the second stone an impression from the first drawing to guide him, scrapes away the parts which he wishes to remain white on the finished impression. The stone must now be etched with acid stronger than the common etching water, having one part of acid and twenty of water; the whole is then washed off with turpentine: this plan is generally used in printing a middle tint from the second stone; the black impression being given from the first stone, a flat transparent brownish tint is given from the second, and the white lights are where the paper is left untouched. The dots are necessary to regulate the placing of the paper on the corresponding parts of the two stones.

LITMUS. See ARCHIL.

LIXIVIATION is the application of water to the fixed residue of bodies, for the purpose of extracting the saline part.

LOCK. A secret fastening for doors and similar things, provided with an arrangement of mechanism designed to prevent the introduction or successful operation of any instrument but that which has been made to fit it, called the key: there is consequently a numerous variety of kinds, qualities, and sizes. A good lock has justly been regarded as the masterpiece of smithery. Locks are of great antiquity; according to M. Denon, they were known in Egypt more than 4000 years ago, which he inferred from some sculptures on the great temple at Karnac, representing locks similar to those now used in that country. It would be difficult to trace the earliest introduction of locks into this country; but there is much evidence showing that very curious and secure locks were made many centuries ago. It appears, also, from the celebrated MSS. of "the famous earl of Glamorgan," entitled "*A Century of the Names and Scantlings of such Inventions,*" &c. as he could "call to mind to have tried and perfected," (his notes being lost,) that the art of lock-making was then by no means in its infancy, as he refers to things as if they were then well known which we now regard as important securities to locks; and some of them are commonly

considered as being of recent invention. For these reasons we think it will not be amiss to introduce in this place some of the "scantlings" alluded to. Making some allowance for the quackery of the noble boaster, the reader, who is acquainted with the construction of our modern locks, will recognise much that is now in use to produce similar effects.

"69. A way how a little triangle-screwed key, not weighing a shilling, shall be capable and strong enough to bolt and unbolt round about a great chest, an hundred bolts, through fifty staples, two in each, with a direct contrary motion, and as many more from both sides and ends; and, at the self-same time, shall fasten it to the place beyond a man's natural strength to take it away; and in one and the same turn, both locketh and openeth it."

"70. A key with a rose-turning pipe and two roses pierced through endwise the bit thereof, with several handsomely-contrived wards, which may likewise do the same effects."

"71. A key perfectly square, with a screw turning within it, and more concerted than any of the rest, and no heavier than the triangle-screwed key, and doth the same effects."

"72. An escutcheon to be placed before any of these locks with these properties. First, the owner, though a woman, may, with her delicate hand, vary the ways of coming to open the lock ten millions of times beyond the knowledge of the smith that made it, or of me who invented it. Second, if a stranger open it, it setteth an alarm a-going, which the stranger cannot stop from running out; and besides, though none should be within hearing, yet it catcheth his hand as a trap doth a fox; and though far from maiming him, yet it leaveth such a mark behind it as will discover him if suspected; the escutcheon or lock plainly showing what money he hath taken out of the box to a farthing, and how many times opened since the owner had been at it."

"The means of giving security to locks," Mr. Ainger observes, "are of two kinds. The first consists in numerous obstacles (commonly called *wards*) to the passage of the key, which requires, therefore, a peculiar form to evade them. The second consists in a number of impediments to the motion of the *bolt*; those impediments being so contrived that their absolute and relative positions must be changed before the bolt can be withdrawn." To these two Mr. Ainger might have added the "*rose-turning pipe*," and the "*secret escutcheon*" from the foregoing "*scantlings*," which also constitute impediments to many *modern* locks. Means of the first class are defective, because a surreptitious instrument need not thread the mazes of the wards; it escapes them by taking a path outside of them to the bolt, which is unavoidably left for the passage of the extremity of the key. Complexity in the form of the wards, therefore, affords no absolute security against the determined initiated picker of locks, as he can take an impression of the position of the wards, and make an instrument (or *skeleton*) that will avoid most of them, and take the most direct path to the bolt or its guards. The guards or impediments to the motion of the bolt are called *tumblers*. A tumbler usually consists of a small lever, one end of which has a little projection, which latches into a notch cut into the bolt, and is kept down by a spring. It is therefore the business of the key, after it has passed the wards, to raise this tumbler out of the notch entirely before the bolt can be moved, the latter motion being effected by the further motion of the key against a curved portion of the bolt. Great exactness in the length of the bit of the key is therefore necessary to make these parts act properly. If the key be too long, it cannot enter the curved portion, and the tumbler is not reached; and if it be too short, by only the thickness of a sheet of writing paper, the tumbler cannot thereby be lifted *quite* out of the notch, and the bolt is, in consequence, immovable. Sometimes the key has a step or notch which acts upon the tumbler, whilst the other portion of the end of the key acts upon the bolt, which adds to the difficulty of false keys. A single tumbler, therefore, constitutes a certain degree of security, and they are usually applied to locks of a medium quality. But as this addition to a lock increases the cost about sixpence, the commonest or cheapest locks have no tumbler, the bolt being held in the position in which the key puts it by the pressure of a spring. Locks

are, however, made, not only without tumblers, but even without wards, for very common purposes; and being sufficiently secure for their objects, and extremely cheap, they are manufactured in immense quantities, chiefly at Wolverhampton.

In 1774 a great improvement in the art of lock-making in this country was made by Barron, who took out a patent for it; it consisted in the employment of two or more tumblers, of the same construction as the single one before described, but so arranged that they must be operated upon at different times, or altogether, and be moved through different spaces, so as to take them completely out of their notches, and set the bolt free to be acted upon. The proper key has therefore a number of steps at the end of the bit, exactly adapted to move the tumblers through the required spaces; and as this arrangement admits of almost endless variations, and is extremely simple in itself, very beautiful and secure locks have continued to be manufactured on the principle ever since it was brought before the public. The facilities of "getting them up" are now so great at Wolverhampton and Birmingham, by the application of machinery for fabricating the separate parts of these (as well as other) locks, chiefly by stamping, that the wholesale price of a good Barron's patent cabinet lock does not exceed two shillings; the sale of them is consequently very great.

Although no doubt can be entertained that Barron really invented the lock we have been noticing, it appears from the statements of Mr. Ainger, that the Egyptian locks now in use are constructed upon the same principle as Barron's; and as these modern Egyptian locks are the same as those observed upon the great temple at Karnac, the invention which we have been regarding as our countryman's, and of modern date, is upwards of 4000 years old. The bolt and a fixed part of the Egyptian lock are, as described by Mr. Ainger, each pierced with any number of holes, arranged in any chosen form; those in the bolt and in the fixed part coinciding when the bolt is locked. These bolts are occupied by pins, which are contained in the fixed part, and descend into the bolt, so as to prevent its motion till they are removed wholly into the fixed part. This is effected by a key having the same number and arrangement of pins, and of such a length, that they elevate the ends of the pins in the lock to the plane of motion between the bolt and the fixed part. This key is introduced laterally through a long tube, at the end of which it acts vertically upon the pins, whose position therefore it is difficult to ascertain. The same principle was afterwards adopted by Mr. Bramah, (who took out a patent for it in 1784,) but without the assistance of wards; his mode of application was, however, very different from the Egyptian. In the latter the security arose from a concealment of the number and position of the impediments; in Mr. Bramah's these were discoverable on inspection, and the security depended on the various degrees of motion which the several impediments required before the bolt could be moved. The office which in ordinary locks is performed by the extreme point of the key, is, in Bramah's, assigned to a lever, which cannot approach the bolt till every part of the lock has undergone a change of position. The lock may be described as consisting of a common axis, on which six levers, crossing the face of the lock, are united as in a joint. Each of these rests upon a separate spring, sufficiently strong to bear its weight, or if depressed by a superior force, to restore it to its proper position when that force is removed. The levers pass through a frame by separate grooves, exactly fitted to their width, but of sufficient depth to allow them a free motion in a perpendicular direction. The joint or carriage of the levers, and the springs on which they rest, are fixed on a circular platform, turning on a centre, and the motion of this platform impels the bolt in either direction by means of a lever. The inviolable restraint upon this lock, by which means it is subjected only to the action of the key, is lodged in a thin plate, bearing at each extremity on a block, and having of course a vacant space beneath, equal in height to the thickness of the block on which it rests. By this plate the motion of the machine is checked or guided in the following manner:—on the edge of the plate which faces the movement there are six notches, which receive the ends of the levers projecting beyond the frame; and while they are confined in this manner,

the motion of the machine is so totally suspended as to defy every power of art to overcome. To understand in what manner the proper key of this lock overcomes these obstacles, it must be observed that each lever has a notch on its extremity, and that those notches are disposed as irregularly as possible. To give the machine a capacity of motion, these notches must be brought parallel to each other, and, by a distinct but unequal pressure upon the levers, be formed into a groove in a direct line with the edge of the plate, which the notches are exactly fitted to receive. The least motion of the machine whilst the levers are in this position, will introduce the edge of the plate into the groove, which controlling the power of the springs, will give liberty to the levers to move in a horizontal direction, as far as the space between the blocks which support the plate will admit, and which is sufficient to give the machine the power of acting on the bolt. The key exhibits six different surfaces, against which the levers are progressively admitted in the operation of opening the lock: the irregularity of these surfaces shows the unequal and distinct degree of pressure which each lever requires to bring them to their proper bearings, in order to put the machine in motion. Hence it appears that unless the various heights of the surfaces expressed on the bit of the key are exactly proportioned to the several distances necessary to bring the notches into a straight line with each other, they must remain immovable. On this principle it would be a matter of great difficulty for any workman, however skilful, to construct a key for the lock when open to his inspection; for the levers, being raised by the subjacent springs to an equal height in the frame, present a plane surface, and, consequently, convey no direction that can be of any use in forming a tally to the irregular surface which they present when acting in subjection to the key. Unless therefore we can contrive a method to bring the notches in the points of the levers in a direct line with each other, and to retain them in that position till an exact impression of the irregular surface, which the levers will then exhibit, can be taken, the workman will be unable to fit a key to the lock, or to move the bolt. If such difficulties occur even when the lock is open to the inspection of a skilful workman, much more must we suppose it out of the power of one who has not access to the internal parts to make a false key. These difficulties render it necessary in making locks of this kind not to fit the key to the lock, but to fit the lock to the key. The key must therefore be made first, and the inequalities upon the surface of the bit worked as chance or fancy may direct, without any reference to the lock. The key being thus completed and applied to the surface of the levers, will, by a gentle pressure, force them to unequal distances from their common station in the frame, and sink their points to unequal depths into the space beneath the plate. While the levers are in this position, the edge of the plate will mark the precise point at which the notch on each lever must be expressed. The notches being cut by this direction, the irregularity which appears when the levers resume their station in the frame, and the inequality of the recesses on the bit of the key, will appear as a seal and its corresponding impression. The moving of the bolt, or other parts of the lock whereby it may be opened, entirely depends on the positive motion of the levers, &c., as any of them would, by being pushed the least degree too much or too little, entirely prevent the bolt from being moved or set at liberty: and as the whole of the levers are restored to their situation when the bolt is withdrawn, the tally, or impression, is totally destroyed, and, consequently, the opening of the lock is left wholly dependent on chance *whilst the said key is absent*, as there is no rule whatever to assist in discovering the required position of each or any of the levers, or other movables, whereby the form of the key necessary to the opening of the lock might be ascertained. Mr. Bramah calculated the number of changes of position that the levers of such a lock are capable of before the right one might be discovered, in the following manner:—  
 "Let us suppose the number of levers, sliders, or other movables, by which the lock is kept shut, to consist of twelve, all of which must receive a different and distinct change in their position or situation by the application of the key, and each of them likewise capable of receiving more or less than its due, either of which would be sufficient to prevent the intended effect; it remains, therefore,



to estimate the number producible, which may be thus attempted:—Let the denominations of these levers, &c be represented by twelve arithmetical progressions, we find that the ultimate number of changes that may be made in their place or situation, is 479,001,500; and by adding one more to that number of levers, &c., they would then be capable of receiving a number of changes equal to 6,227,019,500, and so on progressively, by the addition of others in like manner, to infinity. From this it appears that one lock, consisting of thirteen of the above-mentioned levers, sliders, or other movable parts, may (by changing their places only, without any difference in motion or size) be made to require the said immense number of keys, by which the lock could only be opened under all its variations.”

Statements like the foregoing, apparently founded upon just reasoning, obtained for Bramah's patent an extraordinary degree of reputation, and, for the patentee, during many years, a very lucrative trade; but this and other improvements induced a corresponding study in the art of picking, which finally obtained a triumph over Bramah's invention; and had it not been for the discovery of new means of baffling the picker's art, by the introduction of *false* notches, the reputation of these admirable locks would have been destroyed; but, from the apparent impossibility of discovering the false from the true notches, or of ascertaining those which assist from those which do not assist in the effect the lock is now deemed inviolable; it is manufactured very extensively, and sold at very moderate prices.

In 1805, Mr. Stansbury, an American, came over to this country with a new lock, which he patented, and was very assiduous in endeavouring to get it introduced; in which attempt, however, he met with so little encouragement, that it might be deemed a failure. Nevertheless, there was sufficient originality in his contrivance to merit a notice in this place: the key was of the ordinary shape of those with a pipe, but longer and narrower in the bit, on the lower side of which were a number of pins projecting from its surface; the key had no wards, and the lock, consequently, none; the bolt was not moved by the key immediately, but through the instrumentality of a revolving circular plate, attached to, and underneath which, was a fixed pin, that took into a notch in the bolt; it was therefore the office of the key to remove the impediments to the motion of the revolving plate, which impediments consisted in a number of pins passing through it and another *fixed* circular plate or bridge underneath, the said pins being pressed through both, and made flush with the surface of the upper by the action of springs rivetted to the bridge. The two plates thus locked together were separated by the projecting pins upon the key, which, entering the holes in the upper plate, pressed the spring pins out of them and turned the plate round. The pin-holes in the circular plates were not opposite to the key-hole, but on one side leading towards the bolt, so that to find them out it was necessary to push the key slightly against the plate whilst turning it round.

Mr. Lawson subsequently took out a patent for a lock, the additional security in which consisted in the employment of a sliding curtain, which is drawn before the key-hole in the act of unlocking, thus rendering it impossible to move the bolt whilst a pick remained in the aperture.

In 1816 a lock was invented by Mr. Kemp, of Cork, the security of which consisted in the adaptation of tumblers or sliders, operated upon by two, three, or more small concentric tubes, of different lengths, placed inside the barrel of the key. These tubes were made of such a length as to push back the pins or sliders that detain the bolt, to the required positions, until each one corresponds with the notch that is cut in it for the projecting part of the bolt. Mr. Kemp calls his invention the *union lock*, from the circumstance that it unites the qualities of Barron's and Bramah's locks; and from the manner in which the combination is effected, it affords, according to the inventor, a greater degree of security than either of the former, or than both of them together, supposing a lock of each kind was placed on the same door; and that a dishonest servant, who does not possess any particular ingenuity, may be instructed by a locksmith how to take the requisite impressions of either Barron's or Bramah's

keys, even if he could be intrusted with them only for a few minutes; but this cannot be done with the key of the union lock, as it would require the locksmith to examine it himself, and to make several tools to ascertain its different dimensions, which he could not do without having it in his possession for some considerable time, with leisure to make repeated trials. In this remark of Mr. Kemp's we entirely coincide; and it still applies to all locks hitherto made (1834), that the *keys*, when in the possession of a workman, *may be copied*; and, in many, without possession. Mr. Kemp's invention may supply a partial remedy for this defect; but until a complete one is provided, the art of lock-making is imperfect, and no locks are inviolable.

Viewing the subject in this light, it affords the editor of this work much satisfaction to state, that he has in his possession a lock, the key of which *cannot be copied*; a locksmith possessing no tools by which an exactly similar one can be made; and the machine by which the original one was made, is so arranged as to be deprived of the power of producing another like it. The lock is very simple, very strong, and can be very cheaply made. The cost of a complete machine to make them would be about one hundred pounds; with that they might be manufactured at one-half the expense of any patent lock. The inventor is desirous to have the subject brought before the public under a patent, but want of time to devote himself to such an object at present obliges him to lay it aside.

Locks have been made which required that the key should be a powerful magnet; others, in which an unusual and complicated motion must be given to the key; and others, in which an improper key or instrument would fire a pistol, or ring an alarm, as proposed by the Marquis of Worcester.

Of all the various locks that have of late years been introduced to the notice of the public, Mr. Chubb's has obtained the greatest celebrity. Although it possesses but small claims to novelty, it cannot be denied that it combines, in an eminent degree, the qualities of security, simplicity, strength, and durability; and we think that the persevering and business-like manner in which the ingenious inventor has contrived to fix it before the public eye, has contributed in no small degree to the successful "run" it has had. The chief characteristic in this lock, and that which marks it as Chubb's, is the employment of a lever called a detector, which locks the bolt fast upon any of the tumblers being beyond its assigned range, and shows that some person has been attempting to unlock it by a false instrument. In other respects the lock resembles Barron's and Bramah's; and we are disposed to question its boasted superiority over those admirable inventions for a reason which now forces itself upon our attention. In Barron's and Bramah's the picker has no means of knowing whether the tumblers are lifted too high or not; but in Chubb's he has only to put the detector *hors de combat* in the first instance, by a correct thrust from the outside of the door (which might be accurately measured) so as to fix it fast in its place; the detector then becomes a stopper to the undue ascent of the tumblers, and the extent of their range is thereby correctly ascertained: thus it appears to us, the *detector* might be converted into a *director* of the means of opening the lock.

In 1829 Mr. Gottlieb took out a patent for improvements in locks, which consisted in the application of a piece of paper over the key-hole, so secured as to prevent its being removed without the introduction of a key passing through it; and hence any attempt to break open the lock would be indicated by the fracture of the paper. The paper is introduced and secured by means of a folding shield with a hole in it, similar to the key-hole, in a lock plate; this shield is kept down by a spring catch, which cannot be disengaged for the introduction of a fresh piece of paper, except by the proper key, which is furnished with a projecting stud on the side of the key-stem, for the purpose of disengaging the shield catch when turned. As a source of further security, the patentee proposes to employ cheque-paper, with some design engraved upon it; and by having this paper bound in a cheque-book, and a leaf torn off when required, so that the paper found in the key-hole at any time being compared with the edge of the leaf in the book, the substitution of another paper would be

discovered. There are few cases in which this plan can be advantageously employed.

Messrs. Carpenter and Young, of Willenhall, in Staffordshire, had a patent in 1830 for improvements in locks. Their object appears, from the specification, to be the production of locks of greater security and stability than the common locks without augmenting the cost; and also to construct a latch-lock, somewhat more convenient in use. The greater degree of security is obtained by having a double set of tumblers, one set attached to, and movable with, the bolt, and the other attached to the plate of the lock in the usual way. Projections from the stationary tumblers fit into alits in the movable ones, when they are simultaneously elevated to a given position; and in addition to this, there are notches cut in the upper and lower sides of the movable tumblers, to fit fixed pins projecting from the plate, just above the notches on the upper side, and just below those of the under side when the door is locked, so that the bolt cannot be withdrawn except by a key, which raises each tumbler to an elevation coinciding precisely with the cuts in the original key, and upon this depends the security. Instead of the usual latch or spring bolt to room-door locks, the patentees cause this part to drop into a notch in the striking plate after it has been elevated by passing over an inclined plane upon it. In connexion with this latch is a tumbler, by which it is elevated through the instrumentality of a key, by a handle on one side of the door and a key on the other, or by the key, without using the handle. These contrivances have manifest advantages, and are easily executed by any locksmith.

The application of an inviolable lock to boxes sent by mails or other conveyance, containing money or other valuable property, that can be opened only at stated times, is, of course, an object of desirable attainment in a commercial country like this. For effecting this object a patent was taken out in November, 1831, by William Rutherford, jun. of Jedburgh, in Scotland. This gentleman being a bank agent, had no doubt sensibly felt the importance of having the means of transmitting, from one town to another, bankers' parcels with perfect safety. With this view he introduces against the end of the bolt a circular stop-plate, to prevent the withdrawal of the bolt till the circular plate, which is put in rotation by clock-work, shall have revolved so as to bring a notch opposite the end of the bolt. Now as this notch can be set at pleasure to any required distance from the end of the bolt, the lock may be secured against being opened by its own or any other key, till any assigned number of hours after it has been locked; and as the rate of travelling is known, the box can be secured from robbery till it shall have reached its destination. When this fastening is used for portable boxes or packages, it must be put in motion, and its motion regulated by springs; but when it is to be applied to closets or safes, the most simple mode of giving motion will be by a descending weight, and of regulation by a pendulum; the actuating weight may then be made to rest upon, and disengage a locking bar in connexion with the bolt of the lock, at any assigned number of hours after the fastening has been effected. In this case all that is necessary is to cause the weight to descend down a vertical scale, divided into hours, and to raise it to any assigned number when the door is locked. A still farther security is obtained by the locking-bar itself being prevented from being disengaged by any pressure, except by the descent of the weight, which is made to come, in its descent, into contact with an inclined projection from the lower end of the hour-scale, sending it back and disengaging the locking-bar from a notch therein.

We might extend our descriptive account of locks to numerous others, containing arrangements of parts differing from the foregoing, and each possessing a certain degree of merit, as respects one or more of the necessary qualifications of a lock; but the detail would be uninteresting and profuse; we shall, therefore here close our account of locks extraordinary, by giving the reader a summary of those in general use, of which there are full a hundred times as many as of the former. Indeed, by far the greater number of locks in use are not required as a security against the dexterous thief, but principally as a check upon the intrusive curiosity and meddling of children and servants; and of the

numerous tribe of petty pilferers, there are few who have sufficient knowledge of the nature of common locks to succeed in, or who are daring enough to attempt the picking of them. We have already noticed, at page 104, that a vast quantity of locks are made without any wards or other securities whatever, but the bolt; and these having been stamped with the public approbation, (to our own knowledge for nearly half a century,) what need is there to give two guineas, or two shillings for a lock, when a satisfactory one can be obtained for *two-pence*? Useful trunk locks are indeed manufactured by thousands of groases, at a wholesale price not exceeding *one penny each*! They are chiefly the product of the stamping press; but the malleable-cast-iron-founder is not behind-hand in demonstrating the power of his art in this manufacture. The technical term for wards, in the lock-trade, is *wheels*; thus, they are successively demonstrated according to this point of their quality, *1 wheel, 2 wheels, 3 wheels, 4 wheels*; and to these terms there is a prefixure called *plain*, which means, no wards at all. The wards are simply short pieces of thin plate iron, rivetted on the upper or lower plate, or on both plates, opposite or near to the key hole. If the wards are of a better quality, they are dignified by a higher title, as *one ward round, two wards round, &c.*; which is when the wards make an entire circle, or nearly so, of the lock. They are called *L ward*, or *T ward*, or *Z ward*, when the sectional form of the wards represents the figure of those letters. *Copper wards*, signify the employment of that metal, instead of iron, to adapt them for use in cellars, and other damp places. *Solid wards* are much used, as they are substantial and not dear, being readily made by casting in brass, and turning in the lathe; and they largely assist in making *fancy locks*. The term *fine*, in the lock trade, has about the same meaning as the ordinary application of that adjective to smart persons; they are a little glazed on the surface, to dazzle the eye, but are coarse enough underneath; and they have two bright-headed screws, one or both of which are usually loose. The quality of the plates, bridges, staples, springs, bolts, and other parts of the interior of a lock, is made to assimilate with the quality of the wards, unless ordered to the contrary.

Locks, according to their uses, may be divided into two classes, namely, in-door locks and out-door locks; and of each class there are numerous kinds, sizes, and qualities. We will name the principal, that persons who want them may understand the distinctive names by which they are known in the trade. Commencing with the in-door class, the first kind that occupies our attention are those upon the front doors of houses, called *draw-back locks*, as the bolt, when not locked, is made to spring to, and has a knob for the purpose of drawing it back; they are generally made of iron, and they are, therefore, further designated by the term *iron-rim*, to distinguish from those having wooden stocks, called *spring-stock-locks*, which are of a cheaper and less elegant kind, and are therefore more frequently put to back doors. For the doors of rooms, there are three principal kinds, distinguished by the names of *mortise*, *brass-case*, and *iron-rim* locks. Formerly the latter kind were put on the doors of parlours, and even drawing-rooms; but their unsightly appearance soon caused the substitution of the brass-cased locks. The bright yellow metal was long a favourite, but ingenuity, seconded by good taste, introduced the mortise-lock, which is now rendered so cheap, that scarcely any new houses, excepting those for the very poor, are built without them. By the aid of machinery, and a minute division of labour, mortise-locks are made at an astonishingly low price at Wolverhampton; and the workmanship of even the commonest kind is substantial and durable. As room-door locks are before every body's eyes, it will only be necessary to observe, that all such are specified in the following manner. If there be only one bolt to it which the key shoots, it is called a *dead-lock*, or *clout-lock*; if there be in addition a spring bolt, with a handle to open it, it is called a *two-bolt lock*; and if there be a private bolt besides, it is called a *three-bolt lock*. It is also necessary to specify the kind of handles required, (*knobs or rings, &c.*); the hand (*right or left*); the thickness of the doors; and if plain wards, round wards, tumblers, patent, &c.

Under the general term of cabinet locks, are comprehended a great variety of kinds, such as *cupboard*, *book-case*, *desk*, *portable desk*, *table*, *drawer*, or *till*, *box*,

*chest, caddy, &c.* These also partake of three forms, as respects the manner of fixing them. They are called *straight*, when the plate of the lock is to be screwed with its flat side against the wood-work; *cut*, when the wood is to be cut away to let in the lock flush with the surface; and *mortise*, when a mortise cavity is to be made edgeways in the wood for its reception. The sizes of these locks vary from 1 to 5 inches; they are made in both iron and brass, and the qualities are distinguished by the terms already mentioned.

Of the out-door locks, those used for gates, stables, sheds, &c. are for the most part wooden *stock-locks*; of these there are many qualities; the common or *Banbury*, the *bastard*, the *fine*, and many qualities above the latter, which would require too lengthened an explanation; the internal parts being made of copper, iron, and brass. There are also the D and the P gate locks, and the very numerous family of padlocks; for information upon which we must refer the reader to his locksmith, as a volume might be filled with those and others which we have necessarily omitted.

LOG. A machine or apparatus used to measure the rate of a ship's velocity through the water. For this purpose there are various inventions; but the one mostly used is the following, and called the common log. It is a piece of thin board, forming the quadrant of a circle of about six inches radius, and balanced by a small plate of lead nailed on the circular part, so as to swim perpendicularly in the water, with the greater part immersed. The log line is fastened to the log by means of two legs, one of which is knotted through a hole at one corner, while the other is attached to a pin fixed in a hole at the other corner, so as to draw out occasionally. The log line, being divided into certain spaces, which are in proportion to an equal number of geographical miles, as a half or a quarter minute is to an hour of time, is wound upon a reel. The whole is employed to measure the ship's head-way in the following manner; the reel being held by one man, and the half minute glass by another, the mate of the watch fixes the pin, and throws the log over the stern, which swimming perpendicularly, feels an immediate resistance, and is considered as fixed; the line being slackened over the stern to prevent the pin coming out. The knots are measured from a mark on the line, at the distance of 12 or 15 fathoms from the log; the glass is therefore turned at the instant that the mark passes over the stern; and as soon as the sand in the glass has run out, the line is stopped; the water being then on the log, dislodges the pin, so that the board now only presenting its edge to the water, is easily drawn aboard. The number of knots and fathoms which had run off at the expiration of the glass, determines the ship's velocity. The half-minute glass and divisions on the line should be frequently measured, to determine any variation in either of them, and make an allowance accordingly. If the glass runs 30 seconds, the distance between the knots should be 50 feet. When it runs more or less, it should, therefore, be corrected by the following analogy:—as 30 is to 50 so is the number of seconds of the glass to the distance between the knots upon the line. The heat or moisture of the weather having often a considerable effect upon the glass, so as to make the sand run faster or slower, it should be frequently tried by the vibration of a pendulum. The inventor of this simple and admirable contrivance is unknown; and no mention of it occurs till the year 1607, in an account of an East India voyage, published by Samuel Purchas. Since that period, the log has been in general use, and many improvements have been made upon it. One of the most conspicuous of these improvements, is that invented by Mr. James Hookey, a midshipman in the navy, who received a honorary medal from the Society of Arts for the same.

The advantages gained by Mr. Hookey's invention are, that it gives the distance the ship runs more correctly, as it remains more stationary in the water than the one generally in use; and when required to be hauled into the ship, by giving it a sudden jerk, the toggle swivels round, and disengages the line from the spring, in consequence of which, the log ship reverses its position, and may then be pulled into the ship with the greatest ease. With respect to the lines, Mr. Hookey recommends, that they be saturated in a composition of oil, which makes them more buoyant and pliant, and prevents kinking; it likewise prevents

their contracting, which in a new line is about 20 feet in 50 fathoms. As many serious accidents are likely to occur by getting a false depth of water, in consequence of the contraction of the line attached to the lead, it becomes an object worthy of attention to prevent the possibility of such accidents taking place. The log is formed like a fish. *Fig. 1* represents one running out, and *Fig. 2* the same, in the act of being pulled in; *r* the toggle, *s* the spring; the eye of the line is put on the toggle, which is then pushed under the spring; the flap board *t* falls down, and the fish runs out. When the line is taught, a sudden jerk will make the toggle pass the spring and let go the line; the fish then swings round, the flap board *t* closes, and it is easily pulled in. *Fig. 3* shows the under side; the flap-board *t* is jointed to the fish by the strap of the copper *v*, which passes round a pin *llll*, and this pin is held by the copper strap *w*; the line is attached to the log by a loop which goes in at the mouth, and is held by a peg which forms the eye; the flap-board *t*, if made of copper, has a piece of wood rivetted to it in the middle to stiffen it; if made of wood, a slip of lead or copper *x* is rivetted on, to make it heavy enough to drop down readily when thrown into the water. *Fig. 4* is a top view of one made thin and wide, like a flat dish; the spring *s*, which holds the toggle is underneath, beneath the fish

Fig. 1.



Fig. 2.

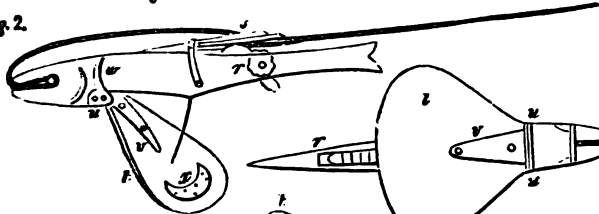


Fig. 3.

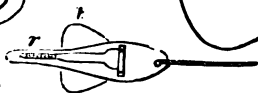
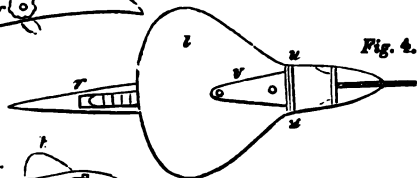


Fig. 4.



and the flap-board *t*; the spring may be above or below in either case. The following are the instructions given for using the log-ship. The eye in the line is to be put over the toggle, on the tail of the fish, and when the line is all run out from the reel, and it becomes taught, by giving it a sudden jerk, the toggle will swivel out; the fish will then reverse its position, float on the surface of the water, and may be hauled into the ship with the greatest ease. When it is necessary to shift the line at the head of the fish, knock out the peg that forms the eye, and the line will then disengage itself; and in attaching another line, make an eye in it, and pass it into the mouth of the fish perpendicularly, through which put the peg that forms the eye, and it will be quite secure. The inventor strongly recommends that all log lines, and lines to the lead, should be saturated for one hour in linseed and lamp oil, three-fourths of the former, and one-fourth of the latter well mixed together, after which, hang them up to dry; contraction will thus be prevented, and they will be pliable and buoyant.

LOGARITHMS are series of artificial numbers, so arranged with reference to a set of natural numbers that the addition of the logarithms shall correspond with the multiplication of the natural numbers belonging to them; and subtraction of logarithms answers for division; while involution, or the raising of powers, is performed by the multiplication of logarithms; and evolution, or the extraction of roots, by the division of logarithms.

To illustrate this, let us take—

For Natural Numbers the Geometrical Series . . } And for their Logarithms the Arithmetical Series }	1	10	100	1000	10000	100000	1000000
	0	1	2	3	4	5	6

From this it appears that the log. of 1 is 0, that of 10 is 1, of 100 is 2, &c.; that the log. of any number below 10 is a fraction, above 10 and under 100 is 1; with a fraction, and between 1000 and 100, is 2 with a fraction, and so on. Hence it is evident that the portion of a log. which constitutes the whole number, and is denominated the INDEX, is always one less than the numbers of figures for which it is the log. This general rule is so easy of application, that the Indexes of Logarithms are never printed in the tables, but left to be supplied by the operator.

The rule for determining the Index descends as well as ascends, and applies with equal facility to numbers below and above unity; but when applied to numbers below unity, it must be distinguished by a negative sign thus—

NATURAL NUMBER.		LOGARITHM.
·000001	.....	6̄·0000000
·00001	.....	5̄·0000000
·0001	.....	4̄·0000000
·001	.....	3̄·0000000
·01	.....	2̄·0000000
·1	.....	1̄·0000000
1·	.....	0·0000000
10·	.....	1·0000000
100	.....	2·0000000
1000	.....	3·0000000
&c.		&c.

To furnish the means of illustrating this important subject by a few examples, and to give the reader an opportunity of working cases by logarithms when the numbers to be operated upon are not very large, we subjoin

A TABLE OF LOGARITHMS OF NUMBERS,  
FROM 1 TO 1000.

NUMBER 1 TO 100, AND THEIR LOGARITHMS.									
1	·0000000	21	·3222193	41	·6127839	61	·7853298	81	·9084850
2	·3010300	22	·3424227	42	·6232493	62	·7923917	82	·9138139
3	·4771213	23	·3617278	43	·6334685	63	·7993405	83	·9190781
4	·6020600	24	·3802112	44	·6434527	64	·8061800	84	·9242793
5	·6989700	25	·3979400	45	·6532125	65	·8129134	85	·9294189
6	·7781513	26	·4149733	46	·6627578	66	·8195439	86	·9344985
7	·8450980	27	·4313638	47	·6720979	67	·8260748	87	·9395193
8	·9030900	28	·4471580	48	·6812412	68	·8325089	88	·9444827
9	·9542425	29	·4623980	49	·6901961	69	·8388491	89	·9493900
10	·0000000	30	·4771213	50	·6989700	70	·8450980	90	·9542425
11	·0413927	31	·4913617	51	·7075702	71	·8512583	91	·9590414
12	·0791812	32	·5051500	52	·7160033	72	·8573325	92	·9637878
13	·1139434	33	·5185139	53	·7242759	73	·8633229	93	·9684829
14	·1461280	34	·5314789	54	·7323938	74	·8692317	94	·9731279
15	·1760913	35	·5440680	55	·7403627	75	·8750613	95	·9777236
16	·2041200	36	·5563025	56	·7481880	76	·8808136	96	·9822712
17	·2304489	37	·5682017	57	·7558749	77	·8864907	97	·9867717
18	·2552725	38	·5797836	58	·7634280	78	·8920946	98	·9912261
19	·2787536	39	·5910646	59	·7708520	79	·8976271	99	·9956352
	·3010300	40	·6020600	60	·7781513	80	·9030900	100	·0000000

NUM.	LOG.	NUM.	LOG.	NUM.	LOG.	NUM.	LOG.	NUM.	LOG.
100	0000000	150	1760913	200	3010300	250	3979400	300	4771213
101	0043214	151	1789769	201	3031961	251	3996737	301	4785665
102	0096002	152	1818436	202	3053514	252	4014005	302	4800069
103	0128372	153	1846914	203	3074960	253	4031205	303	4814426
104	0170333	154	1875207	204	3096302	254	4048337	304	4828736
105	0211893	155	1903317	205	3117539	255	4065402	305	4842998
106	0253059	156	1931246	206	3138672	256	4082400	306	4857214
107	0293838	157	1958997	207	3159703	257	4099331	307	4871384
108	0334238	158	1986571	208	3180633	258	4116197	308	4885507
109	0374265	159	2013971	209	3201463	259	4132998	309	4899585
110	0413927	160	2041200	210	3222193	260	4149733	310	4913617
111	0453230	161	2068259	211	3242825	261	4166405	311	4927604
112	0492180	162	2095150	212	3263359	262	4183013	312	4941546
113	0530784	163	2121876	213	3283796	263	4199557	313	4955443
114	0569049	164	2148438	214	3304138	264	4216039	314	4969296
115	0606978	165	2174839	215	3324385	265	4232459	315	4983106
116	0644580	166	2201081	216	3344538	266	4248816	316	4996871
117	0681859	167	2227165	217	3364597	267	4265113	317	5010593
118	0718920	168	2253093	218	3384565	268	4281348	318	5024271
119	0755470	169	2278867	219	3404441	269	4297523	319	5037907
120	0791812	170	2304489	220	3424227	270	4313638	320	5051500
121	0827854	171	2329961	221	3443923	271	4329693	321	5065050
122	0863598	172	2355284	222	3463530	272	4345689	322	5078559
123	0899051	173	2380461	223	3483049	273	4361626	323	5092025
124	0934217	174	2405492	224	3502480	274	4377506	324	5105450
125	0969100	175	2430380	225	3521825	275	4393327	325	5118834
126	1003705	176	2455127	226	3541084	276	4409091	326	5132176
127	1038037	177	2479733	227	3560259	277	4424798	327	5145478
128	1072100	178	2504200	228	3579348	278	4440448	328	5158738
129	1105897	179	2528530	229	3598355	279	4456042	329	5171959
130	1139434	180	2552725	230	3617278	280	4471580	330	5185139
131	1172713	181	2576786	231	3636120	281	4487063	331	5198280
132	1205739	182	2600714	232	3654880	282	4502491	332	5211381
133	1238516	183	2624511	233	3673559	283	4517864	333	5224412
134	1271048	184	2648178	234	3692159	284	4533183	334	5237465
135	1303338	185	2671717	235	3710679	285	4548449	335	5250418
136	1335389	186	2695129	236	3729120	286	4563660	336	5263393
137	1367206	187	2718416	237	3747483	287	4578819	337	5276299
138	1398791	188	2741578	238	3765770	288	4593925	338	5289167
139	1430148	189	2764618	239	3783979	289	4608978	339	5301997
140	1461280	190	2787536	240	3802112	290	4623980	340	5314789
141	1492191	191	2810334	241	3820170	291	4638930	341	5327544
142	1522883	192	2833012	242	3838154	292	4653829	342	5340261
143	1553360	193	2855573	243	3856063	293	4668676	343	5352941
144	1583625	194	2878017	244	3873898	294	4683473	344	5365584
145	1613680	195	2900346	245	3891661	295	4698220	345	5378191
146	1643529	196	2922561	246	3909351	296	4712917	346	5390761
147	1673173	197	2944662	247	3926970	297	4727564	347	5403295
148	1702617	198	2966652	248	3944517	298	4742163	348	5415792
149	1731863	199	2988531	249	3961993	299	4756712	349	5428254



NUM.	LOG.	NUM.	LOG.	NUM.	LOG.	NUM.	LOG.	NUM.	LOG.
350	5440680	400	6020600	450	6532125	500	6989700	550	7403627
351	5453071	401	6031444	451	6541765	501	6998377	551	7411516
352	5465427	402	6042261	452	6551384	502	7007037	552	7419391
353	5477747	403	6053050	453	6560982	503	7015680	553	7427251
354	5490033	404	6063814	454	6570559	504	7024305	554	7435098
355	5502284	405	6074550	455	6580114	505	7032914	555	7442930
356	5514500	406	6085260	456	6589648	506	7041505	556	7450748
357	5526682	407	6095944	457	6599162	507	7050080	557	7458552
358	5538830	408	6106602	458	6608655	508	7058637	558	7466342
359	5550944	409	6117233	459	6618127	509	7067178	559	7474118
360	5563025	410	6127839	460	6627578	510	7075702	560	7481890
361	5575072	411	6138418	461	6637009	511	7084209	561	7489629
362	5587086	412	6148972	462	6646420	512	7092700	562	7497363
363	5599066	413	6159501	463	6655810	513	7101174	563	7505084
364	5611014	414	6170003	464	6665180	514	7109631	564	7512791
365	5622929	415	6180481	465	6674530	515	7118072	565	7520484
366	5634811	416	6190933	466	6683859	516	7126497	566	7528164
367	5646661	417	6201361	467	6693169	517	7134905	567	7535831
368	5658478	418	6211763	468	6702459	518	7143298	568	7543483
369	5670264	419	6222140	469	6711728	519	7151674	569	7551123
370	5682017	420	6232493	470	6720979	520	7160033	570	7558749
371	5693739	421	6242821	471	6730209	521	7168377	571	7566361
372	5705429	422	6253125	472	6739428	522	7176705	572	7573960
373	5717088	423	6263404	473	6748611	523	7185017	573	7581546
374	5728716	424	6273659	474	6757783	524	7193313	574	7589119
375	5740313	425	6283889	475	6766936	525	7201593	575	7596678
376	5751878	426	6294096	476	6776070	526	7209857	576	7604225
377	5763414	427	6304279	477	6785184	527	7218106	577	7611758
378	5774918	428	6314438	478	6794279	528	7226339	578	7619278
379	5786392	429	6324573	479	6803355	529	7234557	579	7626786
380	5797836	430	6334685	480	6812412	530	7242759	580	7634280
381	5809250	431	6344773	481	6821451	531	7250945	581	7641761
382	5820634	432	6354837	482	6830470	532	7259116	582	7649230
383	5831988	433	6364879	483	6839471	533	7267272	583	7656686
384	5843312	434	6374897	484	6848454	534	7275413	584	7664128
385	5854607	435	6384893	485	6857417	535	7283538	585	7671559
386	5865873	436	6394865	486	6866363	536	7291648	586	7678976
387	5877110	437	6404814	487	6875290	537	7299743	587	7686381
388	5888317	438	6414741	488	6884198	538	7307823	588	7693773
389	5899496	439	6424645	489	6893089	539	7315888	589	7701153
390	5910646	440	6434527	490	6901961	540	7323938	590	7708520
391	5921768	441	6444386	491	6910815	541	7331973	591	7715875
392	5932861	442	6454223	492	6919651	542	7339993	592	7723217
393	5943926	443	6464037	493	6928469	543	7347998	593	7730547
394	5954962	444	6473830	494	6937269	544	7355989	594	7737864
395	5965971	445	6483600	495	6946052	545	7363965	595	7745170
396	5976952	446	6493349	496	6954817	546	7371926	596	7752463
397	5987905	447	6503075	497	6963564	547	7379873	597	7759743
398	5998831	448	6512780	498	6972293	548	7387806	598	7767012
399	6009729	449	6522463	499	6981005	549	7395723	599	7774268

NUM.	LOG.	NUM.	LOG.	NUM.	LOG.	NUM.	LOG.	NUM.	LOG.
600	7781513	650	8129134	700	8450980	750	8750613	800	9030900
601	7788745	651	8135810	701	8457180	751	8756399	801	9036325
602	7795965	652	8142476	702	8463371	752	8762178	802	9041744
603	7803173	653	8149132	703	8469553	753	8767950	803	9047155
604	7810369	654	8155777	704	8475727	754	8773713	804	9052560
605	7817554	655	8162413	705	8481891	755	8779470	805	9057959
606	7824726	656	8169038	706	8488047	756	8785218	806	9063350
607	7831887	657	8175654	707	8494194	757	8790959	807	9068735
608	7839036	658	8182259	708	8500333	758	8796692	808	9074114
609	7846173	659	8188854	709	8506462	759	8802418	809	9079485
610	7853298	660	8195439	710	8512583	760	8808136	810	9084850
611	7860412	661	8202015	711	8518696	761	8813847	811	9090209
612	7867514	662	8208580	712	8524800	762	8819550	812	9095560
613	7874605	663	8215135	713	8530895	763	8825245	813	9100905
614	7881684	664	8221681	714	8536982	764	8830934	814	9106244
615	7888751	665	8228216	715	8543060	765	8836614	815	9111576
616	7895807	666	8234742	716	8549130	766	8842288	816	9116902
617	7902852	667	8241258	717	8555192	767	8847954	817	9122221
618	7909885	668	8247765	718	8561244	768	8853612	818	9127533
619	7916906	669	8254261	719	8567289	769	8859263	819	9132839
620	7923917	670	8260748	720	8573325	770	8864907	820	9138139
621	7930916	671	8267225	721	8579353	771	8870544	821	9143432
622	7937904	672	8273693	722	8585372	772	8876173	822	9148718
623	7944880	673	8280151	723	8591383	773	8881795	823	9153998
624	7951846	674	8286599	724	8597386	774	8887410	824	9159272
625	7958800	675	8293038	725	8603380	775	8893017	825	9164539
626	7965743	676	8299467	726	8609366	776	8898617	826	9169800
627	7972675	677	8305887	727	8615344	777	8904210	827	9175055
628	7979596	678	8312297	728	8621314	778	8909796	828	9180303
629	7986506	679	8318698	729	8627275	779	8915375	829	9185545
630	7993405	680	8325089	730	8633229	780	8920946	830	9190781
631	8000294	681	8331471	731	8639174	781	8926510	831	9196010
632	8007171	682	8337844	732	8645111	782	8932068	832	9201233
633	8014037	683	8344207	733	8651040	783	8937618	833	9206450
634	8020893	684	8350561	734	8656961	784	8943161	834	9211661
635	8027737	685	8356906	735	8662873	785	8948697	835	9216865
636	8034571	686	8363241	736	8668778	786	8954225	836	9222063
637	8041394	687	8369567	737	8674675	787	8959745	837	9227255
638	8048207	688	8375884	738	8680564	788	8965262	838	9232440
639	8055009	689	8382192	739	8686444	789	8970770	839	9237620
640	8061800	690	8388491	740	8692317	790	8976271	840	9242793
641	8068580	691	8394780	741	8698182	791	8981765	841	9247960
642	8075350	692	8401061	742	8704039	792	8987252	842	9253121
643	8082110	693	8407332	743	8709888	793	8992732	843	9258276
644	8088859	694	8413595	744	8715729	794	8998205	844	9263424
645	8095597	695	8419848	745	8721563	795	9003671	845	9268567
646	8102325	696	8426092	746	8727388	796	9009131	846	9273704
647	8109043	697	8432328	747	8733206	797	9014583	847	9278834
648	8115750	698	8438554	748	8739016	798	9020029	848	9283959
649	8122447	699	8444772	749	8744818	799	9025468	849	9289077

NUM.	LOG.	NUM.	LOG.	NUM.	LOG.	NUM.	LOG.	NUM.	LOG.
850	9294189	880	9444827	910	9590414	940	9731279	970	9867717
851	9299296	881	9449759	911	9595184	941	9735896	971	9872192
852	9304396	882	9454686	912	9599946	942	9740509	972	9876663
853	9309490	883	9459607	913	9604708	943	9745117	973	9881128
854	9314579	884	9464523	914	9609462	944	9749720	974	9885590
855	9319661	885	9469433	915	9614211	945	9754318	975	9890046
856	9324738	886	9474337	916	9618955	946	9758911	976	9894496
857	9329808	887	9479236	917	9623693	947	9763500	977	9898946
858	9334873	888	9484130	918	9628427	948	9768083	978	9903389
859	9339932	889	9489018	919	9633155	949	9772662	979	9907827
860	9344985	890	9493900	920	9637878	950	9777236	980	9912261
861	9350032	891	9498777	921	9642596	951	9781805	981	9916690
862	9355073	892	9503649	922	9647309	952	9786369	982	9921115
863	9360108	893	9508515	923	9652017	953	9790929	983	9925533
864	9365137	894	9513375	924	9656720	954	9795484	984	9929951
865	9370161	895	9518230	925	9661417	955	9800034	985	9934362
866	9375179	896	9523080	926	9666110	956	9804579	986	9938769
867	9380191	897	9527924	927	9670797	957	9809119	987	9943172
868	9385197	898	9532763	928	9675480	958	9813655	988	9947569
869	9390198	899	9537597	929	9680157	959	9818186	989	9951963
870	9395193	900	9542425	930	9684829	960	9822712	990	9956352
871	9400182	901	9547248	931	9689497	961	9827234	991	9960737
872	9405165	902	9552065	932	9694159	962	9831751	992	9965117
873	9410142	903	9556878	933	9698816	963	9836263	993	9969492
874	9415114	904	9561684	934	9703469	964	9840770	994	9973864
875	9420081	905	9566486	935	9708116	965	9845273	995	9978231
876	9425041	906	9571282	936	9712758	966	9849771	996	9982593
877	9429996	907	9576073	937	9717396	967	9854265	997	9986952
878	9434945	908	9580858	938	9722028	968	9858754	998	9991305
879	9439889	909	9585639	939	9726656	969	9863238	999	9995655

It is not our province, in this brief article, to explain the use of the larger Logarithmic Tables, as whoever possess such have of course their author's own explanations, and therefore the following illustrative examples are selected to suit the table here given.

MULTIPLICATION, as already stated, is performed by the *addition* of Logarithms, thus:—

To multiply 368 by 22·5, we place opposite to each other the	NUMBERS	<i>and their</i>	LOGARITHMS.	
	368	.....	2·5658478	} Add.
	<u>22·5</u>	.....	<u>1·3521825</u>	
Product of Numbers 8280·	.....		<u>3·9180303</u>	Sum of Log.

Here the first factor, 368, being a whole number, consisting of *three* figures, has for its index 2; and the second, 22·5, having but *two* figures, without the decimal part, has for its index 1. To these are subjoined the decimal portions of the logarithms taken from the Table, and the sum of the two being found in the Table opposite to 828, which would be the answer were the index 2; but as the index is 3, the answer must be made to consist of *four* figures, which is done by supplying to the right of the figures a cipher, making the answer, as above, 8280.

Required the capacity of an excavation, whose length is 295, breadth 128, and depth 25 feet.

NUMBERS.		LOGARITHMS.	
295	.....	2·4698220	
128	.....	2·1072100	
25	.....	1·3979400	
Product. 944000	.....	<u>5·9749720</u>	Sum.

Again, let the numbers 3·2, 25, 1·12, ·125, ·015, and ·004 be continually multiplied together.

NUMBERS.		LOGARITHMS.	
3·2	.....	0. 5051500	
25	.....	1· 3979400	
1·12	.....	0· 0492180	
·125	.....	<u>1· 0969100</u>	
·015	.....	<u>2· 1760913</u>	
·004	.....	<u>3· 6020600</u>	
Product ·000672	.....	<u>4· 8273693</u>	

The number in the table corresponding with the decimal part of the sum of these logarithms is 672, but as the index is 4 there must be three cyphers prefixed to this number to constitute the product or answer which is therefore ·000672.

Division, being the reverse of Multiplication, and performed by subtraction of logarithms, requires but little explanation.

For illustration, let 944000 be divided by 3200, thus :—

NUMBERS.		LOGARITHMS.	
Dividend 944000	.....	5·9749720	From
Divisor. . 3200	.....	<u>3·5051500</u>	Subtract.
Quotient . 295	.....	<u>2·4698220</u>	Difference.

Again, let ·00815 be divided by ·0025.

NUMBERS.		LOGARITHMS.	
·00815	.....	3·9111576	
·0025	.....	<u>2·3979400</u>	
Quotient . 326	.....	<u>1·5132176</u>	

Let 493 be divided by 937.

NUMBERS.		LOGARITHMS.	
Dividend. . 493	.....	2·6928469	
Divisor. . . 937	.....	<u>2·9717396</u>	
Quotient . ·526	.....	<u>1·7211073</u>	

Here the logarithm to be subtracted being the greater of the two, the index of the difference is 1, which renders the quotient a decimal.

INVOLUTION, or the raising of powers, is performed by multiplying the logarithm of the given number by the index of the power to which it is required to be raised, thus :—

Let 26 be squared, or raised to the second power.

NUMBERS.		LOGARITHMS.	
26	.....	1.4149733	
		.2	
Power . . . . 676	.....	<u>2.8299466</u>	Product.

Required the cube root, or third power of 9.

NUMBERS.		LOGARITHMS.	
9	.....	0.9542425	
		3	
Power . . . . 729	.....	<u>2.8627275</u>	

Required the 9th power of 1.05, which will be the amount of £1 in nine years, at 5 per cent. compound interest.

NUMBERS.		LOGARITHMS.	
1.05	.....	0.0211893	
		9	
Amount . . 1.55 or £1.11s. . . . .	.....	<u>0.1907037</u>	

From this example it is manifest that the amount of money laid out at compound interest for 50, 100, or any other number of years, can be found by logarithms with the greatest facility, though the operation by common arithmetic is very tedious, requiring a distinct multiplication for each year.

EVOLUTION, or the extraction of roots, is performed by dividing the logarithm of the given number by the index of the root required. Let this be illustrated by finding the square root of 324.

NUMBERS.		LOGARITHMS.	
324	.....	2)2.5105450	
Root . . . 18	.....	<u>1.2552725</u>	

Required the ninth root of 1.55

NUMBERS.		LOGARITHMS.	
1.55	.....	9)0.1903317	
Root . . . 1.05	.....	<u>0.0211479</u>	

As it may occasionally be desirable to apply the foregoing table to numbers beyond its limits, the manner of doing so is subjoined.

To find the logarithm of a number exceeding three figures, it is evident that the logarithm of the first three must be augmented by such a proportion of the difference between it and the next greater logarithm, as the remaining figures of the given number bears to unity with as many cyphers as may be required; thus—to find the logarithm of 47583, the logarithm of the first three figures 475 is 6766936, and the next greater is—

6776070

9134 their difference.

Now take the proportion as 1 : 9134 :: 83 : 75

$$\begin{array}{r} 83 \\ \hline 27302 \\ 73072 \end{array}$$

1,000)75.8022, or 7496 nearly · which being added

to the first logarithm, gives 4.6774516 for the logarithm of 47583. On the contrary, if the number be required for a logarithm not to be found in the table, to the first three figures corresponding with the next less logarithm, are to be subjoined the result of the following proportion; viz.—As the difference between the next greater and next less logarithm is to unity, with as many cyphers as may be required, so is the difference between the given logarithm and the next less to the figures to be subjoined to those found in the table. Thus—Suppose it were required to find the natural number corresponding with 4.668455

The next less logarithm in the table is . . . . .	6963564
The next greater . . . . .	6972293
Difference . . . . .	8729
The given logarithm . . . . .	6968455
Next less . . . . .	6963564
Difference . . . . .	4891

Now—As 8729 : 100 :: 4891 : 56

100
8729)489100(56
43645
52650
52374
<hr style="width: 100%;"/>

Which being subjoined to 497, the three figures found in the table opposite to the next less logarithm, give 49756 for the number of the given logarithm.

**LOGWOOD.** A hard compact wood, so heavy as to sink in water; of a fine grain, capable of being polished, and so durable, as to be scarcely susceptible of decay. Its predominant colour is red, tinged with orange, yellow, and black. It yields its colour both to spirituous and watery menstrua. Alcohol extracts it more readily and copiously than water. The colour of its dye is a fine red, inclined a little to violet or purple, which left to itself, becomes yellowish, purple, and at length black. Acids turn it yellow, alkalies deepen the colour, and give it a purple or violet hue. A blue colour is obtained from logwood, by mixing verdigris with it in the dye bath. The great consumption of logwood is for blacks, to which it gives a lustre and velvety cast; it is also extensively used as a red, purple, or black dye to beech, and various white woods.

**LONGIMETRY.** The measuring of lengths and distances, both accessible and inaccessible. Accessible distances are measured by the application of some lineal measure, as a foot, a chain, &c. Inaccessible distances are measured by taking angles, &c. by means of proper instruments; such as the circumferentor, quadrant, and theodolite.

**LOOM.** A machine for weaving cloth, of which there are various kinds. See WEAVING.

**LOZENGES, or TROCHES,** are small articles of confectionery, sometimes medicated, and usually made up of the form of thick wafers. The basis of their composition is refined sugar, which is finely pulverised and sifted, then mixed up in a mortar, with just a sufficient quantity of thick mucilage, to make a very firm paste; to which is added the essential oil or other flavouring ingredient or medicament. When the paste, so made, is of the right consistence to be rolled out into a solid and smooth sheet, that operation should be quickly performed by a cylindrical roller, the ends of which should run upon slips or projections above the board, of the thickness of the intended lozenge. Thus rolled out, the lozenges should be quickly cut out with the punch or cutter; which is usually the hollow frustum of a cone, with sharp edges at the narrow end, and

is made either of tinned plate, iron, or steel. As soon as these are cut out, the remaining pieces which formed the interstices between the lozenges, should be rolled up, or beaten together in a mortar, then rolled and cut out again; and this operation continued, until the whole material is used up. But if further quantities are required of the article under operation, then the remnants of one cutting may be added to the succeeding batch. In the pharmacopeias, gum tragacanth is recommended as the mucilage to be used in making medicinal lozenges. Lozenge makers, however, rarely use this gum, as besides being much dearer, it is inconvenient in use, and does not make so elegant a lozenge as gum Arabic or Senegal. The latter when in proper quantity, (which is about one ounce of very thick mucilage to a pound of finely powdered sugar,) gives to the lozenges made therewith, a semi-transparency and hardness, which is regarded in the trade as a test of a well-manufactured article. When essential oils, (such as peppermint, roses, cinnamon, &c.) are used as the flavouring ingredients, they should not be added until the paste is otherwise nearly completed, as their great volatility causes a waste of their essential properties when long under the hands of the operator. In making lozenges containing balsams, such as the *tolu*, the balsams may be advantageously mixed with the mucilage; and those in which powders, such as ginger are to be mixed, the manner of performing it is a matter of indifference.

**LUTE, or LUTING.** A mixed, tenacious, ductile substance, which being applied between the junctures of distillatory and other vessels, grows solid by drying, and effectually stops up the crevices. Lutes are of different kinds, according to the nature of the operations to be made. When vapours of watery liquors, and such as are not corrosive, are to be contained, it is sufficient to surround the joiner of the receiver to the nose of the alembic, or of the retort, with slips of paper or of linen, covered with flour paste. In such cases also slips of wet bladder are very conveniently used. When more penetrating and dissolving vapours are to be contained, a lute is to be employed of quicklime slacked in the air and beaten into a liquid paste with the whites of eggs. This paste is to be spread upon linen slips, which are to be applied exactly to the joinings of the vessels. This lute is very convenient, easily dries, becomes solid, and sufficiently firm. Of this lute, vessels may be formed hard enough to bear polishing on the wheel. When acid or corrosive liquors, are to be contained, recourse is had to *fat lute*; which is made of finely powdered clay, sifted through a fine sieve, and moistened with water; this paste is then well beaten in a mortar with boiled linseed oil, rendered drying by litharge. This lute easily takes and retains the forms given to it. It is generally rolled into cylindrical sticks of a convenient size for use. They are applied by flattening them to the joinings of the vessels, which ought to be perfectly dry, because the least moisture would prevent the lute from adhering. When the joinings are well closed with this fat lute, the whole is to be covered with slips of linen spread with lute of lime, and whites of eggs. These slips are to be fastened with packthread. The second lute is necessary to keep on the fat lute, because this latter remains soft, and does not become solid enough to stick on alone. Fine porcelain clay, mixed with a solution of borax, is well adapted to iron vessels, the part received into an aperture being smeared with it.

## M.

**MACHINE** signifies anything used to augment or regulate force or motion. The simplest machines, namely, the lever, the wheel and axle, the pulley, the inclined plane, the wedge and the screw, are usually denominated the mechanical powers, since all machinery is necessarily compounded of some of them: hence a machine is a combination, or a peculiar modification of some of the mechanical powers.

**MADDER.** A substance very extensively employed in dyeing; it is the root of a trailing plant that grows very abundantly in the south of Europe. It is cultivated in England and Holland also; but the best is said to be that

brought from Smyrna and Cyprus. The roots of the plant are carefully peeled, dried in the air, and afterwards in a kiln, in the same way as hops are dried in Kent. They are then chipped and pulverized. The best roots are about the thickness of a goose-quill; semi-transparent, of a reddish colour and strong smell. The red colouring matter of madder is soluble in alcohol, which, on evaporation, leaves a residuum of a deep red. Fixed alkali forms in this solution a violet, the sulphuric acid a fawn coloured, and the sulphate of potash a fine red precipitate. A variety of shades are obtained by the addition of alum, chalk, nitre, sugar of lead, and the muriate of tin.

**MAGIC.** The imposture by which a few individuals, who had become acquainted with some of the more remarkable phenomena of nature, and the operations of chemistry, managed to enslave the minds and bodies of their ignorant fellow-creatures. An acquaintance with the motions of the heavenly bodies, and the variations in the state of the atmosphere, enabled its possessor to predict astronomical and meteorological phenomena, with a frequency and accuracy which could not fail to invest him with a divine character. The power of bringing down fire from heaven, even at times when the electric influence was itself in a state of repose, could be regarded only as a gift from heaven. The power of rendering the human body insensible to fire, was an irresistible instrument of imposture; and in the combinations of chemistry, and the influence of drugs and soporific embrocations on the human frame, the ancient magicians found their most available resources. The secret use which was thus made of scientific discoveries, and of remarkable inventions, has no doubt prevented many of them from reaching the present times; but though we are very ill informed respecting the progress of the ancients in various departments of the physical sciences, yet we have sufficient evidence that almost every branch of knowledge had communicated its wonders to the magician's budget; and we may even obtain some insight into the scientific acquirements of former ages, by diligent study of their fables and their miracles.

The science of *acoustics* furnished the ancient sorcerers with some of their best deceptions. The imitation of thunder in their subterranean temples, could not fail to indicate the presence of a supernatural agent. The golden virgins, whose ravishing voices resounded through the temple of Delphos; the stone from the river Pactolus, whose trumpet notes scared the robber from the treasure which it guarded; the speaking head, which uttered its oracular responses at Lesbos; and the vocal statue of Memnon, which began at break of day to accost the rising sun,—were all deceptions derived from science, and from a diligent observation of the phenomena of nature.

The principles of *hydrostatics* were equally available in the work of deception. The marvellous fountain which Pliny describes in the island of Andros as discharging wine for seven days, and water for the rest of the year; the spring of oil which broke out in Rome to welcome the return of Augustus from the Sicilian war; the three empty urns which filled themselves with wine at the annual feast of Bacchus in the city of Elis; the glass tomb of Belus, which was full of oil, and which, when once emptied by Xerxes, could not again be filled, the weeping statues, and the perpetual lamps of the ancients;—were all the obvious effects of the equilibrium and pressure of fluids.

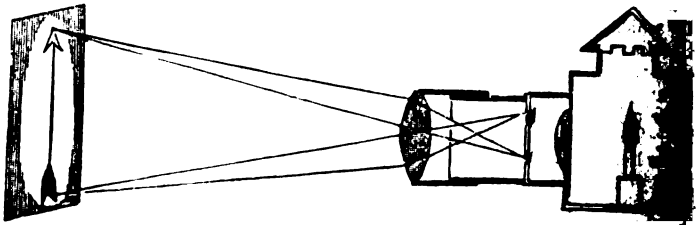
Although we have no direct evidence that the philosophers of antiquity were skilled in *mechanics*, yet there are indications of their knowledge, by no means equivocal, in the erection of the Egyptian obelisks, and in the transportation of huge masses of stone, and their subsequent elevation to great heights in their temples. The powers which they employed, and the mechanism by which they operated, have been studiously concealed; but their existence may be inferred from the results otherwise inexplicable, and the inference derives additional confirmation from the mechanical arrangements which seem to have formed a part of their religious impostures. When in some of the infamous mysteries of ancient Rome, the unfortunate victims were carried off by the gods, there is reason to believe that they were hurried away by the power of machinery; and when Apollonius, conducted by the Indian sages to the temple of their gods, felt the earth rising and falling beneath his feet like the agitated sea, he was no



doubt placed upon a moving floor, capable of imitating the heavings of the waves. The rapid descent of those who consulted the oracle in the cave of Trophonius—the moving tripods which Apollonius saw in the Indian temples of the walking statues of Antium, and in the temple of Hierapolis—and the wooden pigeon of Archytas, are specimens of the mechanical resources of ancient magic.

But of all the sciences, *optics* is the most fertile in marvellous expedients. The power of bringing the remotest objects within the very grasp of the observer, and of swelling into gigantic magnitude the almost invisible bodies of the material world, never fails to inspire with astonishment even those who understand the means by which these prodigies are accomplished. The ancients, indeed, were not acquainted with those combinations of lenses and mirrors which constitute the telescope and the microscope; but they must have been familiar with the property of lenses and mirrors to form erect and inverted images of the objects. There is reason to think that they employed them to effect the apparition of their gods; and in some of the descriptions of the optical displays which hallowed their ancient temples, we recognise the transformations of the modern phantasmagoria.

**MAGIC LANTERN.** An optical machine employed to throw a magnified image of paintings upon glass or any transparent substance on a white screen in a darkened chamber. It has generally been devoted to the amusement of children, paintings of a ludicrous description being its usual accompaniments; but it may be employed with propriety to illustrate the principles of the sciences, by a selection of suitable diagrams. The apartment in which the exhibition is made should be completely darkened, and no light allowed to escape from the lantern except what passes through the glasses. To increase the light, a concave reflector is frequently used, of such a curvature, that the candle is in its focus, so that the rays proceeding from it, fall parallel upon the glass next the candle. The glass slides upon which the pictures are made, are generally of sufficient length to contain several sets of figures; the sliders being introduced by an opening, cut in each side of the tube containing the lenses. A section of this machine is shown below.



**MAGNESIA.** One of the primitive earths, having a metallic base called magnesium. It is a soft white powder; of specific gravity 2.3. It renders the syrup of violets, and the infusion of red cabbage, green; and reddens turmeric. It is infusible, except by the oxy-hydrogen blow-pipe. It has scarcely any taste, and no smell; is nearly insoluble in water, but absorbs that liquid with the production of heat. Its chief use is in medicine.

**MAGNET, OR LOADSTONE,** is a ferruginous stone or ore of iron; it has the property of attracting iron, of pointing itself in a certain direction, and of communicating the same property to steel or iron.

**MAHOGANY.** The beautiful reddish brown coloured wood of which household furniture is now chiefly made. It is a native of the warmest parts of America and the West Indies. It thrives in most soils in the tropical climates, but varies in texture and grain according to the nature of the soil. On rocks it is of a smaller size, but very hard and weighty, of a close grain, and beautifully shaded; while the produce of the low and richer lands is observed to be

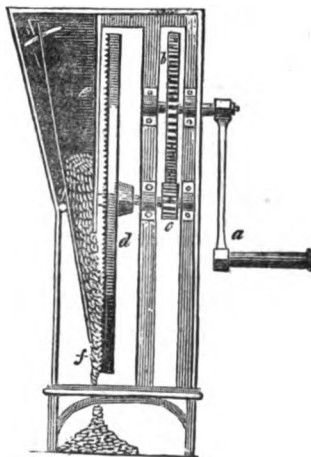
more light and porous, of a paler colour, and open grain; and that of mixed soils to hold a medium between both. The tree grows very tall and straight, and is usually four feet in diameter. On account of the difficulty of transporting the mahogany timber from the forests, when a tree is of great thickness they cut it into short logs, otherwise the great weight and bulk would be unmanageable with the restricted means available on the spot; and with the view of equalizing the burthen or draft of the cattle (oxen), the logs are long in proportion to their diminished thickness. The largest log ever cut in Honduras was of the following dimensions:—length, 17 feet; breadth, 57 inches; depth 64 inches; measuring 5,421 feet of plank, of 1 inch in thickness, and weighing upwards of 15 tons.

**MAIZE, or INDIAN CORN** being now cultivated to some extent in different parts of this country, we have given the engraving on the following page of a machine for husking the corn, or separating the grains from the ear, a process equivalent to that of thrashing employed for other grain. *a* is a crank handle or winch, which being turned, gives motion to a spur wheel *b*, and thereby causes a rapid revolution of the pinion *c*, on the shaft of which is fixed a large circular cast-iron plate *d*, the face of which is studded all over with very numerous cast-iron teeth or knobs; *e* is the hopper of the figure of a narrow inverted quadrangular pyramid; it has one of its sides movable, and capable of a very simple adjustment by turning as a lever upon a fulcrum at *g*, by which movement the aperture of discharge is enlarged or contracted; and it should be so regulated as only to admit of the central stalks of the cobs of the Indian corn to pass; these differ in size according to the fertility of the soil, the climate, and the treatment of the plant. At *h* there is a curved slot mortise through the side of the hopper, through which the stem of a thumb-screw passes from the outside into the movable plate, which is confined in any position at pleasure by half a turn of the screw.

In America, where these machines are common, they are usually worked by one person turning the winch *a*, which gives very rapid revolutions to the plate *d*, whilst a boy drops one by one the cobs of Indian corn into the hopper, which causes each cob successively to spin round upon its axis, or stalk with great velocity, rubbing or knocking out the grain in its progress; and so effectual is the process, that a single turn of the winch *a* completely husks a large cob of maize.

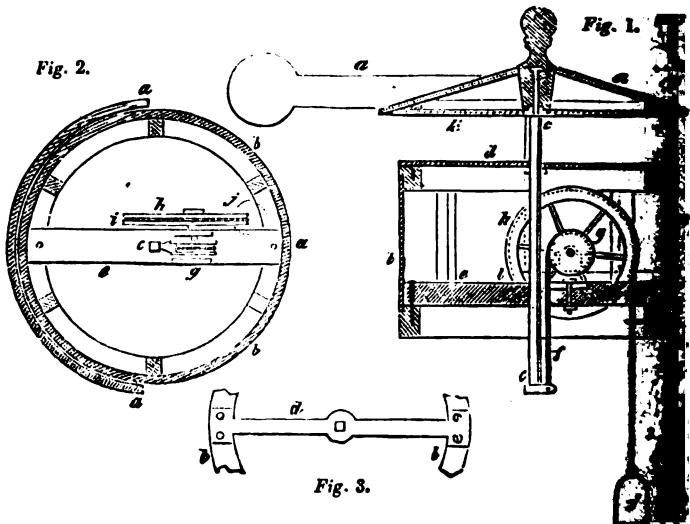
**MALLET.** A large kind of hammer, made of wood; they are of various forms, according to the kind of work to be performed by them.

**MALT.** Grain which has become sweet from the conversion of its starch into sugar, by an incipient growth or germination artificially induced, called *malting*. In malting barley the usual method is to steep the grain in a sufficient quantity of water for two or three days, till it swells, becomes plump, somewhat tender, and tinges the water of a bright brown or reddish colour. The water being then drained away, the barley is spread about two feet thick upon a floor, where it heats spontaneously, and begins to grow by first shooting out the radicle. In this state the germination is stopped, by spreading it thinner, and turning it over once every four or five hours for two days; after which it is again made into a heat, and suffered to become sensibly hot to the hand, which usually takes place in from twenty to thirty hours; when it is spread out to cool, and afterwards dried upon the kiln, by a low and continuous heat, which renders it dry and crisp. The common malt-kiln is a square building, widening gradually within, from



the fire-place to a floor above, on which the malt is laid. It may be compared to an inverted pyramid, having a fire-place in its vertex, and its base covered by a floor, on which the malt is dried by the heat, and more or less smoke (according to the nature of the fuel and management of the fire), which ascends from the fire beneath. The floor is usually formed of tiles supported upon iron bars; the tiles have large holes made nearly through them from the lower side, and then very small holes pricked entirely through them. In some kilns webs of wire, covered with hair-cloth, are used instead of the perforated tiles. The fuel commonly used is either coke or stone coal; sometimes wood, and the hot-air that passes through the malt, has previously passed through the naked fire. An improvement in this respect has, however, been lately introduced, which, by means of a cast-iron tube, open externally to receive the air, and extended across the furnace and horizontal flue to acquire heat, thus delivers the air to the malt at an elevated temperature, and free from smoke, as well as other impurities. Distillers and brewers, whose buildings are so relatively situated, may thus lead the air cylinder for their malt kilns through the furnaces of their stills or boilers, and thus save the necessity of a distinct furnace for the malt, and a great portion of the cost of fuel.

An important improvement in malt kilns was introduced by Mr. Salmon, a maltster of Stokeferry, in Norfolk, in 1829, and for which he took out letters patent. This consists in admitting a portion of the hot-air from the flue into the part of the kiln above the malt, during the process of drying, instead of causing all the hot air to pass through the malt according to the customary practice. The object of this arrangement is to promote the evaporation, and to carry away the moist air instead of allowing it to be again condensed, and deposited on the surface of the malt. The grain floor of the kiln is made in the usual way, a portion of the heated air passing through the small perforations



therein; but the hot air is admitted into the upper part of the kiln through large openings furnished with tubes, or by small flues which extend higher than the surface of the malt on the floor, and thus a portion of the hot air is conveyed in a dry state to the space above the surface of the malt. The vapour that arises from malt when drying in the kiln, is discharged into the air through a hood or cowl, which turns round by means of a vane, so that the opening shall always be in the opposite direction to that from which the wind blows: but the aperture of the common cowl always remains of the same magnitude.

and therefore the draft through the fire admits of no accurate regulation; and malt-houses are not unfrequently set on fire in making high-dried malt, because the fire is not perfectly manageable. Mr. Perkins, of Stanstead, in Hertfordshire, has, however, invented a cap (for which he received an honorary medal from the Society of Arts), possessing all the advantages of the common cowl, with the additional one of regulating the opening, and consequently the draft and intensity of the fire. It also entirely excludes wet when the wind is still and the rain falls perpendicularly in showers, which is not effectually done with the common cowl, to the great injury of the malt lying on the floor, and the rusting of the wire-work when that material is employed for the floor. Fig. 1 in the engraving on p. 124, represents the turn-cap *a a* and the neck *b b* in section; *e c* a square iron bar or spindle, sliding through a square hole in the middle of the iron plate or bar in *d*, and through another in the middle of the beam *e*; the cap *a a* turns upon the upper cylindrical portion of this bar, and the bar itself is supported and hangs entirely on the chain *f* attached to the pulley *g*, which is mounted on a carriage on the beam *e*; on the same axis is a larger pulley *h* with a chain attached to it at *i*, and from which a chain and weight *j* hangs, sufficient to balance the weight of the sliding bar *c*, and turn-cap *a a*. By raising the weight *j* the cap is lowered and finally shut; and on lowering the weight the cap is raised quite up, or held at any intermediate height. Fig. 2 is a section of the neck between the bars *d* and *e*. Fig. 3 is a top view of the bar *d*, showing the hole through which the spindle passes; *k*, Fig. 3, is a similar iron bar across the cap *a a*. The chain *f* should be attached quite close to the bar *c c*, to lessen its tendency to lean on one side. Malt may be dried upon the same kilns as are used for drying grain generally; see the article **KILNS**.

**MALTHA.** The mineral tallow of Kirwan, said to be found on the coast of Finland, also on the lake Baikal, in Siberia. It resembles wax, and has hence been denominated sea-wax. It is a solid substance, spec. grav. 0.77, white, brittle, stains paper like oil, melts with a moderate heat, and burns with a blue flame and much smoke; dissolves readily in oil, and imperfectly in hot alcohol. The term *maltha* was likewise applied by the ancients to a species of cement, of which there were two kinds, native and factitious; one of the latter consisted of pitch, wax, plaster, and grease; another (which, it is said, they used in their aqueducts) was made of lime slacked in wine, and incorporated with melted pitch and fresh figs.

**MANDREL** is the name given to a kind of pulley, forming an important part of a lathe; there are various kinds,—see **TURNING**.

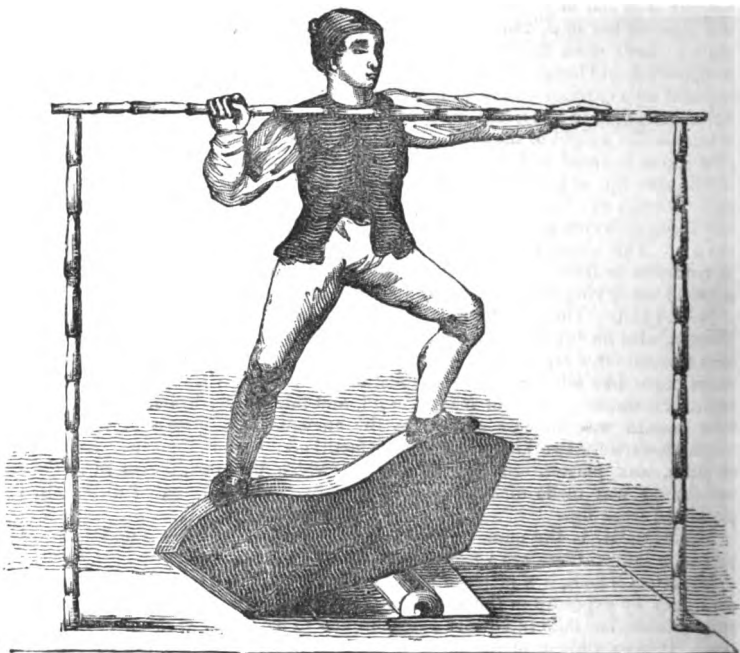
**MANGANESE**, is a metal of a dull whitish colour, but soon changes to a dark grey by exposure to the air. It is hard, brittle, rough in its fracture; not pulverizable, but falls to powder when broken to pieces by spontaneous oxidation. It is so difficult of fusion, that no heat yet exhibited has caused it to run into masses of any considerable magnitude. Concentrated sulphuric acid attacks manganese, at the same time that hydrogen gas is disengaged. Nitric acid dissolves it with effervescence, and the escape of nitrous gas. A spongy, black, and friable matter remains, which is a carburet of iron. The oxide is more readily soluble in nitrous acid. Manganese is dissolved in the usual manner by muriatic acid. In the dry way, the oxide of manganese combines with such earths and saline substances as are capable of undergoing fusion in a strong heat. Manganese melts readily with most of the other metals, but rejects mercury. Gold and iron are rendered more fusible by a due admixture of manganese, and the latter metal is rendered more ductile. Copper becomes less fusible, and is rendered whiter, but of a colour subject to tarnish. The ore of manganese, known in Derbyshire by the name of *black wadd*, is remarkable for its spontaneous inflammation when thoroughly dried with oil. Manganese is chiefly used by the glass makers and potters, but since the discovery of chlorine, its application in the art of bleaching has much extended its usefulness. See **BLEACHING**.

**MANGLE.** A domestic machine of great utility, employed in smoothening Eens, as a substitute for the heated irons extensively used for the same purpose.

In the common mangle, as most of our readers well know, the linen or other



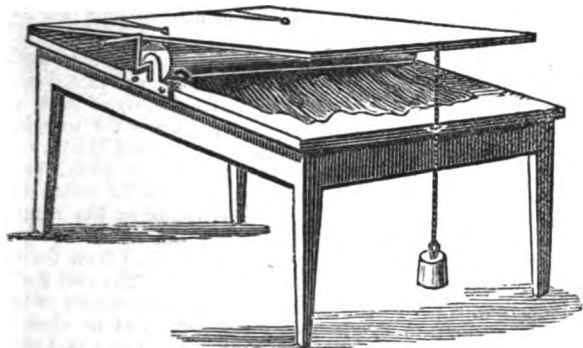
articles to be mangled, are wrapped round wooden rollers, which are placed upon a solid level bed or floor, and upon the rollers is placed a large oblong box, which is filled with stones, or other heavy substances, in order that they may press with great force upon the rollers, while the box is moved backwards and forwards upon them, by means of a handle attached to an upper roller or windlass, to which straps from each end of the moving box are attached. By this machine, the operation of mangling is very well done, but the labour is excessive on account of the necessity of frequently arresting and changing the motion of the heavy box. In China, mangling is performed in the most perfect manner by a machine of the same kind as our common mangle, but far simpler. A concavity is formed in the floor of the apartment, of a hard and polished



wood, into which is placed a roller, with the cloth intended to be mangled, around it. A heavy stone, (so shaped as to rest on either end while the operator examines his work,) is then glided on the roller, and its elevations alternately pressed by his feet, so that the article shall receive an equal pressure on every part of it. The man supports himself by bamboos placed in the floor for that purpose, as represented by the above engraving, and after a labour of four or five minutes, the work is admirably finished.

Another extremely simple machine, delineated in the engraving on p. 127, has been applied with good effect, by Mr. Pitcher, for the purpose of mangling linen. It consists of a roller about 4 inches in diameter, and 30 inches long, with a piece of the thick woollen cloth used for ironing, firmly fixed thereon. The roller is turned round by means of a winch, and has its bearings at the ends in two stout iron plates, screwed to the sides of the table. Upon the roller rests a board, of the length and width of the table, secured to it at one end by hinges, and has at the other end a weight suspended to it, the pressure of which, upon turning the winch, winds the woollen cloth, and the damp linen articles laid upon it, so tight upon the roller, that by continuing the motion, the linen becomes as smooth as upon the common unwieldy mangle. The roller rests upon the table,

and the iron plates allow it to rise and fall, according to the quantity of cloths wrapped round it. This mangle, when not in use, serves the purpose of a common table, by merely unshipping the roller; this circumstance, and the facility and cheapness with which it may be constructed by any common workman, are great recommendations to its employment by such as cannot afford, or who have not adequate occasion for, the more complex and perfect machines.

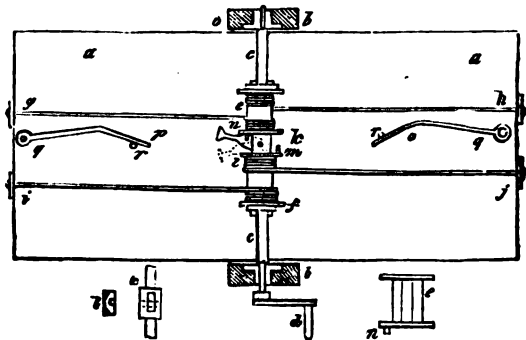


An important improvement in the construction of the common mangle, first described, was effected about thirty years ago by Mr. Baker, of Fore-street, London, by which the otherwise unwieldy heavy box was moved with great facility backwards and forwards, by a continuous motion of the handle in one direction; and by the addition of a fly wheel to equalize the motion, a great amount of muscular exertion is saved to the individual working the machine. The motion employed by Mr. Baker is highly ingenious and interesting; and although it has been superseded by others of a simpler and more efficient kind, we cannot pass it by without a brief notice of its construction. It consists of a wheel, having a series of teeth or pins on the outside of the periphery, and another series of similar teeth or pins upon the inside of the periphery. In these teeth a revolving pinion works, traversing from the inside to the outside of the wheel, or the contrary way, during the reversing of the motion, instead of confining the pinion to one course, as in working an ordinary cog wheel. To enable the pinion to do that, a portion of the periphery of the wheel is cut away, through which the pinion passes, by rolling round from the outside into the inside, then around the latter again to the former; the axis of the pinion has therefore a range or play to the extent of the thickness of the rim of the wheel, between the inner and the outer cogs. From the foregoing, it is evident that by the continued action of the pinion, it turns the wheel round nearly a revolution one way, and then through the same space the contrary way; and as the two ends of the loaded box are attached by chains to the reciprocating wheel, it is made to traverse backward and forward. This traversing motion, by the revolution of a pinion, was subsequently improved by Mr. Elisha Peechey, and applied to a very convenient mangle, for a model of which Mr. Peechey was awarded the silver medal of the Society of Arts. This mangle had what may be called an upper and a lower rack inside a slot, which was made to traverse by the revolution of a pinion, as in Baker's patent mangle. The pinion in this case has a stationary axis, and the bar in which the racks are formed has a pin in its upper side, which sliding between grooves in the plummer blocks, keeps it bearing against the pinion when the upper rack is operated upon; another pin is fixed on the lower side of the bar, which in like manner keeps it in contact with the pinion when the latter is operating upon the lower side, the bar containing the racks thus always accommodating itself to the continuous motion of the pinion, which thereby impels it alternately in opposite directions. A mangle of this kind, in which several important improvements have been introduced, is manufactured by Mr. Christie of Sheffield, in a style of great



excellence, and at a very moderate cost. Instead of the top and bottom rack, this mangle is provided with a stout metallic bar, with a row of pegs along the middle of one side of it; and parallel with the line of these pegs there is a deep projecting flange, designed to confine a pinion in its hold upon the pegs as the rack traverses backwards and forwards, by acting successively on each side of the series of pins; and the rack is so balanced by weighted levers, that as the pinion passes round the endmost peg, at either end the rack is alternately raised and depressed. For a particular description of this machine, see *Register of Arts*, Vol. I. New Series, p. 168.

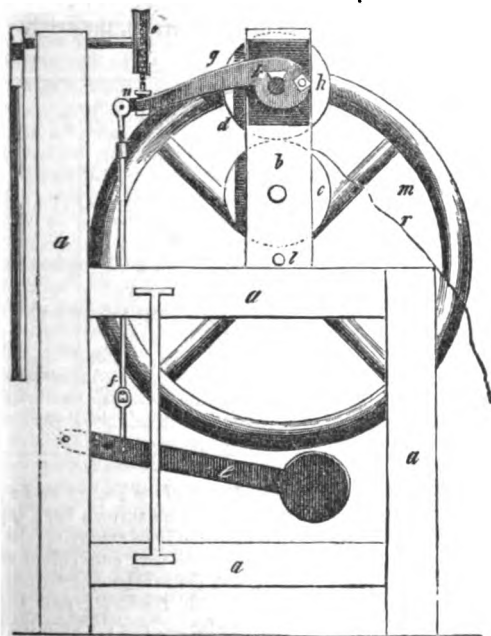
A new and very simple method of producing the alternate motion of a mangle-box, by the continuous motion of the handle in one direction, invented by John Thurrel, was lately communicated to the Society of Arts, a plan of which is represented in the subjoined engraving. *aa* is the mangle-box, *bb* parts of the frame which support the axis *cc*; *d* the cranked handle, *e* and *f* two barrels loose on the axis *cc*; to the barrel *e* are fastened two cords, one of which, after making several coils round the barrel, passes from its *under* side to the eye *h*, where it is secured; while the other, after having in like manner coiled round the barrel, is also delivered from its under side to the eye *g*. To the barrel *f* are also fastened two cords, which being delivered from the *upper* side of the barrel are respectively fixed in the eyes *i* and *j*. The part *k* of the axis, between the barrels, is made square, and is cut out longitudinally to receive the lever *l*, which is secured in its place by a pin, but so as to allow of lateral motion between the two barrels; each of these barrels has a stud *m* and *n*, so placed that the lever may be shifted to engage either of them, and consequently to oblige that barrel with which it may be engaged to revolve, together with the axis; *o* and *p* are two alternating irons, each with an eye at one end, through which a pin *q* passes, in order to fasten them to the mangle box; their height above the box is such as to allow them just to clear the axis when passing under it, and the motion of each is limited, but on opposite sides, by the adjusting pins *rr*.



The figure represents the lever *l* as engaged with the stud *n*, and consequently as being fixed in the barrel *e*; now if the barrel is turned so as to wind up the cord *h*, the cord *g* will proportionably unwind, and the mangle-box will move from left to right till the end *l* of the lever comes in contact with the alternating iron at the point *o*. By continuing to turn the handle, the end of the lever slides from *o* to the end of the iron, and is brought into the position shown by dotted lines; the stud *n* is consequently disengaged, and the barrel *e* becomes loose; at the same time the lever engages the stud *m*, and fixes the barrel *f*. The handle being still turned in the same direction as at first, begins to wind up the cord *i*, and thus makes the box begin to move from right to left, the cord *j* at the same time unwinding proportionally. When the left hand alternating iron has begun to come under the axle, the end of the lever will touch it at *a*,

will slide along it to the point of the angle, and in doing so will bring it to the position shown in the figure, the barrel *e* being now fixed, and the barrel *f* being loose. Thus is accomplished the production of an alternating motion of the box, by continuing to turn the handle always in the same direction. The back of the lever *l* is bevelled off, so that if the handle is turned in a wrong direction, it passes between the studs *m* and *n*, and not engaging either barrel produces no motion of the mangle-box. *Fig. 2* is one of the barrels separated; and *Fig. 3* the square middle part of the axis, showing the slit in which the lever traverses.

In 1823, a patent was taken out by Mr. Snowdon for an erect or vertical mangle, by which it was intended to obviate an objection sometimes made to the common horizontal mangles that we have been describing; namely, the great space they occupy. Several patents have indeed been taken out for mangles of the vertical kind; but, for reasons that we are not acquainted with, have not been much patronised by public adoption. The following invention was patented in 1828, by Mr. Samuel Wilkinson, of Holbeck, in Yorkshire, but, as stated in the specification, the machines so constructed were to be called "Bullman's Cabinet Mangles." The annexed figure affords a side view of the principal parts of the machine, those which are omitted being left out for the better elucidation of the more essential parts. *aa* represents one side of the frame, *b* one of the cheeks supporting the lower roller *c*; the upper roller *d* rests upon the lower one. Pressure is given by a weighted lever *e*, suspended by the rod *f* from another lever *g*, which turns upon a fulcrum at *h*, and has a

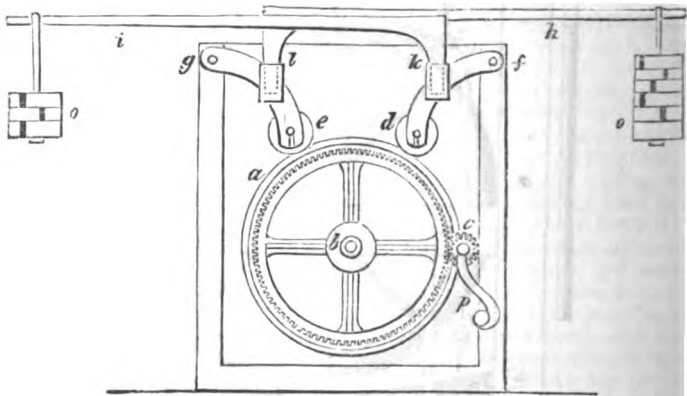


piece of hardened steel & dovetailed into it, against which the axis of *d* works. The lower roller *c* has a wheel on its axis, turned by a pinion on the axis *l* of the fly wheel *m*, and the fly wheel is made to revolve by a handle on one of its arms. To raise the upper roller to place under it the articles to be mangled, the arm *g* is connected to a similar arm on the opposite side by a cross bar *n*,



suspended by a chain from the wheel *o*, which being turned by the lever *a*, elevates the arm *g*, and with it the upper roller *d*. The line *r* merely represents the situation of the mangling cloth. The patentee is silent in his specification as to the mode of working the machine, whether by continuous or reciprocating action. Some articles will require to be passed under the rollers more than once, and we can discover no method in the present machine, of doing this, but by reversing the motion, which will require attention on the part of the mangler, who must watch until the goods are nearly past the rollers, and then reverse the motion; whilst the common mangle performs this of itself. If the mangling cloth were an endless web passing over other rollers, a rotatory motion alone would be required; but the patentee does not state in his specification that he uses any such arrangement. The machine seems calculated to obtain a considerable degree of pressure in a convenient manner.

The sketch below is taken from a small model of a mangle that was exhibited amongst others at the National Repository, invented by Messrs. Brook and Webster, of Thornhill, in Yorkshire. *a* is a drum or cylinder, at one end of which, and on the same axis is fixed the toothed wheel *b*, which is turned by the pinion *c* by the revolution of the winch *p*. *d* and *e* are two rollers, round which the cloth to be mangled is wrapped; these rollers are placed in the curved arms shown, which turn upon centre pins at *f* *g*; *h* and *i* are levers, the bended ends of which fit into sockets in the curved arms; (in the model, the levers were rivetted to the arms, which the editor considered to be inconvenient) *o* *o* are weights suspended to the levers to give the pressure, which can be increased or diminished at pleasure, either by altering the actual quantities of the weights or changing their situation on the levers. In order to remove the clothes from either of the rollers, or to put others on, the weights must be taken



off the lever, the lever must be lifted out of its socket or be lifted up with the curved arm which turns upon its end, and be thrown back together. With some slight modifications (such as an easy mode of removing the load from the levers, &c.) this compact mangle may be made very convenient and effective.

**MANNA.** A white sweet juice, which oozes from the trunk, branches, and leaves, of several kinds of trees; but the ash, the larch, and the alhagi afford it in the largest quantities. Sicily and Calabria, are the countries from whence it is chiefly obtained; where it flows naturally from the ash, and attaches itself to its sides in the form of white transparent drops; but the extraction of this juice is facilitated by incisions made in the tree during summer. Its smell is strong, and its taste sweetish, and slightly nauseous. Water dissolves it, hot or cold. If it be boiled with lime, clarified with white of egg, and concentrated by evaporation, it affords crystals of sugar. This substance forms the basis of many purgative medicines.

**MANOMETER**, an instrument for measuring the rarefaction and condensation of elastic fluids, but especially that of the atmosphere. It differs from the barometer which shows only the weight of the superincumbent column of air; whereas the manometer shows the density, which depends on the combined effect of weight and the action of heat. It is sometimes called manoscope. Among the various contrivances of this kind may be mentioned that of the Hon. Robert Boyle, which he calls a statical barometer; which consists of a bubble of thin glass about the size of an orange, which being counterpoised in an accurate pair of scales, rises and sinks with the alterations of the atmosphere. This instrument, however, does not show the cause of the difference of density in the atmosphere, whether it be from a change of its own weight, or its temperature, or both. The manometer constructed by Mr. Ramsden, and used by Capt. Phipps, in his voyage to the North Pole, was composed of a tube of small bore with a ball at the end; the barometer being 2.97, a small quantity of quicksilver was put into the tube, to take off the communication between the external air and that confined in the ball, and the part of the tube below this quicksilver. A scale is placed on the side of the tube, which marks the degrees of dilatation arising from the increase of heat in this state of the weight of the air, and has the same graduation as that of Fahrenheit's thermometer, the point of freezing being marked 32°. In this state, therefore, it will shew the degrees of heat in the same manner as a thermometer. But if the air becomes lighter, the bubble inclosed in the ball being less compressed, will dilate itself, and take up a space as much larger as the compressing force is less; therefore the changes arising from the increase of heat will be proportionably larger, and the instrument will show the differences in the density of the air, arising from the changes in its weight and heat. Mr. Ramsden found that a heat equal to that of boiling water, increased the magnitude of the air from what it was at the freezing point by  $\frac{2}{100}$  of the whole. Hence it follows, that the ball and part of the tube below the beginning of the scale, is of a magnitude equal to almost 414 degrees of the scale. If the height of both the manometer and thermometer be given, the height of the barometer may be determined also.

**MAPLE**. From the juice of this tree obtained by tapping, the Americans prepare a sugar, and the Highlanders, it is said, an agreeable wine.

**MARANTA**, or *Indian Arrow Root*. From this root, washed, pounded, and scoured in water, is obtained the fashionable starch called arrow-root, much used for infant and invalid food.

**MARBLE**, a fine kind of lime-stone, (a carbonate of lime;) it is found in extensive masses in most parts of the world. It occurs in beds in granite, gneiss, &c, rarely in secondary rocks, but is found in all the great ranges of primitive rocks in Europe. Its hard, compact texture, semi-transparency and lustre, when polished, has made it a great favourite in architecture and house building. The finer kinds, especially those used by the statuary are chiefly obtained from Italy; but there are a great variety of beautiful marbles in Great Britain and Ireland. See *Jameson's Mineralogy*, Vol. II. For an improved method of sawing marble and other hard stone, see **SAWING**. An artificial marble is frequently made from plaster of Paris, quicklime, salt, ox-blood, pieces of glass, and stones of different colours. These are beaten to an impalpable powder, and mixed up to the consistency of paste with beer or milk. When thoroughly dried in the form which is intended to be given to it, it is rubbed with sand paper and polished with emery and oil. Mr. Wilson's process for making artificial stone chimney pieces, is described under the article **STONE**.

**MARBLING of books**. See **BOOKBINDING**.

**MARINE ACID**. See **ACID MURIATIC**.

**MARINER'S COMPASS**. See **COMPASS**.

**MARL**. An earth, of which there are three principal kinds, the calcareous, the argillaceous, and the siliceous; according as the lime, the clay, and the silicx abound in them.

**MARLINE-SPIKE**. An iron tool, tapering to a point, used to separate the strands of a rope, in order to introduce those of another, when they are to be spliced, or joined evenly, without knotting.

**MARQUETRY.** A kind of inlaid work, composed of a tasteful variety of fine woods, of different shades and colours, glued or fastened in thin slices on a solid ground; the work is not unfrequently enriched with silver, brass, tortoiseshell, ivory, and other beautiful substances; and the pieces, duly prepared beforehand, are successively laid together according to a design or drawing.

**MASONRY.** The art of hewing and preparing stones of their due proportions and figure, and of joining them together, in building houses, and other works.

**MASSICOT.** The yellow oxide of lead. See **LEAD**, and **PAINTING**.

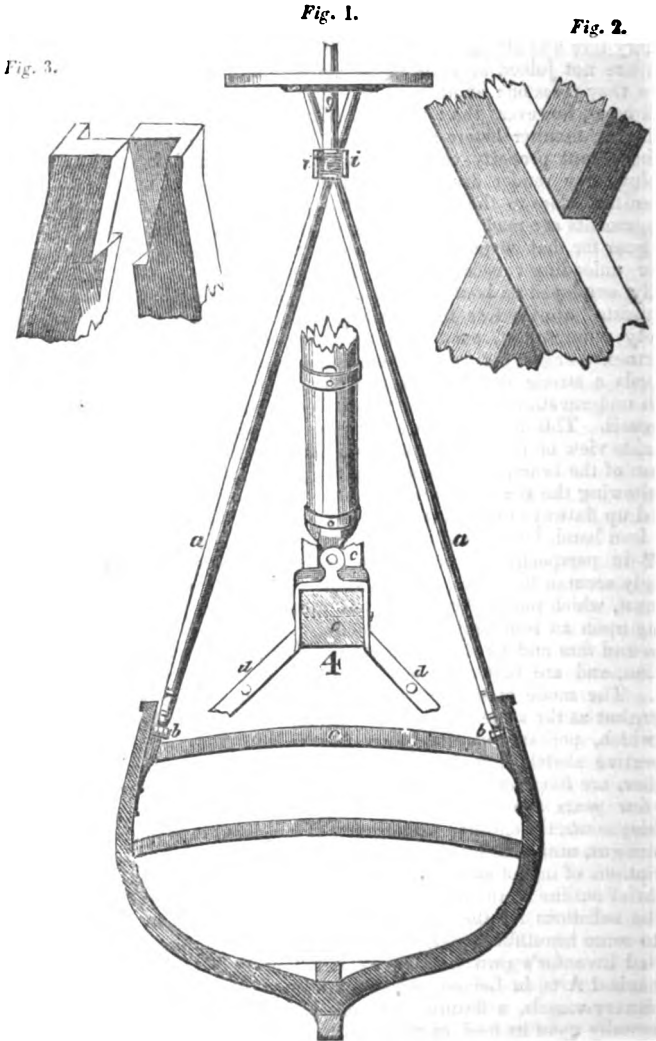
**MAST.** A long round piece of timber, raised perpendicularly on the keel of a ship, upon which are attached the yards, the sails, and the rigging. A mast, according to its length, is either formed of one single piece, which is called a pole mast, or composed of several pieces joined together, each of which retains the name of mast separately. A *lower mast* being the lowest, is accordingly so called; the foot of it rests on a block of timber called the step, which is fixed on the keelson. A *top mast* is raised at the head or top of the lower mast, through a cap, and supported by trestle trees, (See the article **FID**.) The *top-gallant mast*, is a smaller mast than the preceding, and is secured to its head in the same manner. The *top-gallant royal mast* is a yet smaller mast sometimes raised above the last mentioned; but in some ships it denotes a continuation of the top-gallant mast, above the rigging; it is then called a *pole top-gallant*, to distinguish it from a *stump top-gallant mast*, which terminates just above the rigging. The *main-mast* is the largest mast in a ship, and stands nearly in the middle, between the stem and the stern. The *fore-mast* is that which stands near the stem, and is next in size to the main-mast. The *mizen-mast* is the smallest mast, and stands about half way between the main mast and the stern. *Made-mast* is a term applied to a mast composed of several pieces of timber in contradistinction to those made of a single stick. *Rough-mast*, denotes a spar fit for making a mast. Besides the parts already mentioned, in the construction of masts, with respect to their length, the lower masts of the largest ships are always made of several pieces of timber firmly united, by stout iron hoops. As these are generally the most substantial parts of various tiers, a mast thus formed is esteemed stronger than one consisting of only a single timber, the strength of which, by internal defects, may be considerably impaired. Attempts were made some years ago to introduce hollow masts, the invention of Mr. George Smart, of Westminster Bridge; and they were, we believe, partially adopted for small vessels; such masts, from their cylindrical figure, being stronger than solid masts, containing a similar mass or weight of materials. Sir Robert Seppings has likewise distinguished himself, amongst his other improvements in ship building, in the construction of masts, for which he took out a patent; the specification of which informs us that, for ships of the line, frigates, and large merchantmen, whose masts are more than 33 inches in diameter, they are to be composed of twelve principal pieces, in the following manner. Four pieces of small square balk timber are to be united diagonally, so as to form a hollow square in the centre. Externally on each of these four pieces are to be tree-nailed two additional pieces. The twelve pieces thus united, are now to have their angular edges cut away, and planed down, so as to bring the whole to a circular figure, when an iron hoop is to be placed round them, and the angular spaces filled up with slips of wood. In connecting the pieces of timber so as to form the required length of mast, bars of iron are to be inserted longitudinally into mortices made in both to receive them; and the several pieces are to cross each other or "break-joint." In constructing the masts for smaller vessels than before mentioned, only eight or four balk timbers are to be employed, (according to their dimensions,) which are to be connected longitudinally and transversely in a similar manner to that described. Hollow masts so formed, are not only much stronger than when solid, but they effect a great economy in the cost, in the facility of making, and of transportation.

A patent for "Improvements in Masting Vessels," was taken out in 1826.

by Mr. Thomas Guppy, of Bristol; from the enrolled specification of which, we collect the following information, exhibiting the principal features of the invention. Instead of a single pole fixed in the keel, in nearly a vertical position, constituting what is called a mast, the patentee employs two poles or spars, the heels of which are fixed on to the opposite extremities of the beam of a vessel, and likewise to the sides; the poles are then so inclined to one another, as to be connected at their upper ends, and thus form with the line of the deck an isosceles triangle; this is the outline of the construction as applied to sloops, or ordinary fore and aft rigged vessels. For square rigged or larger vessels, the poles are not joined at their upper extremities, but at several feet below it, where they cross one another, presenting the figure of an open pair of shears. In all cases, however, the lower ends of the poles are fastened in the situation and in the manner before-mentioned. Thus situated, they are invested with the important property or capability of being lowered forward or aft, as the occasion may render desirable, by the employment of hinge joints at their extremities, close to the deck. At the junction of the poles above, suitable arrangements are made for the fixing of top masts therein, which are provided with gear for that purpose, as well as for the *masting of other vessels*; for loading or unloading vessels; and for those other purposes for which sheers are usually employed on board of ships. The principal rigging for these "double pole masts" are the fore and aft stays, the ordinary side shrouds being comparatively unimportant, except for the purpose of going aloft. At *Fig. 1* in the annexed engraving *a a* are the two poles, having joints at *b b*, from whence proceeds a strong iron band which clasps the opposite ends of the beam *c*, which underneath diverges into two iron straps, that are bolted to the side of the vessel. This arrangement is explained by *Fig. 4*, which exhibits a perspective side view of the iron work which connects the poles to the vessel, with a portion of the beam, and a pole *c c* is the beam, with the iron band bolted to it, and showing the straps *d d* that are secured to the sides of the vessel, and are turned up flatways towards them. The poles are connected together at *e* by a stout iron band, by scarfing and crossing each other, as shown by the separate *Fig. 2* in perspective; *f* is the top, where the upper ends of the poles are strongly secured to one another by straps and bolts; *g* is the lower end of the top-mast, which passes through a hole adapted to it in the top, with its heel resting upon an iron projection, which is of one piece with the band *e*. For sloops and fore and aft rigged vessels generally, the poles *a a* terminate at their junction, and are united by scarfing, previous to putting on the strong iron band. The mode of scarfing the patentee leaves to the genius of the mast maker, but at the same time points out one mode which he most approves of, and which, perhaps, cannot be much excelled. This mode is shown in the perspective sketch, *Fig. 3* Connected to the band which unites the poles together, are fixed long iron links *i i*, for hooking in, or *seizing* the shrouds to.

A few years ago Lieut. Molyneux Shuldham, R.N. took out a patent for *revolving masts*, the enrolled specification of which exhibits in sixty-five diagrams and designs, numerous modifications and applications of the principle to various descriptions of inland as well as sea-going vessels. As our space will only admit of a brief outline of the nature of the invention, we must refer the reader who may be solicitous for the details, to the inrolled document in Chancery-lane, and to some beautiful models illustrative of the inventions (constructed by the talented inventor's own hands), exhibited at the National Museum of the Mechanical Arts, in Leicester-square, London. The mast instead of being, as in ordinary vessels, a fixture, is herein made to revolve upon its axis, or turn horizontally upon its heel, carrying with it the sails, yards, and other rigging attached to it, and thereby instantly changes the direction of the vessel's motion. The power required to perform these evolutions may be the wind or manual labour, or both conjointly. As the action of the wind will naturally tend to produce the desired effect in both cases, whatever manual force may be required to assist the operation must be very little indeed; that is to say, according to modern phraseology, the maximum of effect is produced by a minimum of labour. It will be evident from this arrangement of the machi-

nery of a ship; that fewer hands will be required to work it, that the running rigging may be much simplified and curtailed, and the wear and tear greatly reduced. These improvements are considered applicable to open boats, deck boats, and small craft in general; to vessels employed in inland navigation, coasting vessels, and particularly those navigating intricate channels and



ivers. But Mr. Shuldham does not consider them applicable to vessels of war and vessels of small tonnage, that carry lumber in their decks, owing to the room required for the revolving bases of the masts. The masts are variously supported, according to the tonnage of the vessels: in decked boats and small

vessels, an iron or wooden pivot is sufficient; in larger vessels anti-friction rollers are fixed to the revolving base, which work between two annular plates, secured to the gunwhales and deck.

**MASTIC.** A resinous substance in the form of tears, of a pale yellow colour, and farinaceous appearance; having little smell and a bitter taste. It flows naturally from the tree; but this process is accelerated by making incisions in the bark. It is extensively used in the composition of varnishes. Pure alcohol and oil of turpentine dissolve it chiefly, the residue partaking of the nature of caoutchouc. An agreeable odour is given out by mastic when heated; it is, in consequence, much used in fumigations, and in the fabrication of pastiles.

**MATTER** is generally understood to mean that solid, inert, divisible substance, accessible to the senses, of which all bodies in the universe are formed. Dr. Woodward was of opinion that matter is originally, and is really, various; Sir Isaac Newton, however, considered matter as homogenous in all bodies, and the difference of form to be owing to a varied arrangement of the corpuscles of one homogenous substance. That matter is one and the same thing in all bodies, and that all the varieties we observe arises from the various shapes it puts on, seems very probable, from a general observation of nature in the generation and destruction of bodies. Thus water rarefied by heat becomes vapour, a great collection of which forms clouds; these condensed, descend in hail or rain; part of this collected on the earth constitutes rivers; another part combines with earths or metallic matter, forming minerals and crystallized salts; another enters the roots of plants, and expands itself into all the wonderful variety and magnificence of the vegetable creation. From the vegetable matter animals derive their support and means of reproduction; and however these mineral, vegetable, and animal productions may change, the same individual matter is never destroyed, but reappears under other combinations.

**MATRIX.** The stone in which metallic ores are found enveloped; the same term is applied by type-founders to the metallic mould in which the letters are cast.

**MEAD.** A wine prepared from honey; a quantity of good honey, with rather more than its weight of water is to be boiled, scummed, and evaporated until it is of a consistence that will float an egg; the liquor is then to be strained and poured into a barrel; this barrel, which ought to be nearly full, must be exposed to a heat as equable as possible, from 75° to 90° Fahr., keeping the bung-hole slightly covered but not closed. The spirituous fermentation will take, and continue during two or three months, according to the heat. During this fermentation, the barrel is to be occasionally filled up, with more of the liquor of honey (previously saved for that purpose) to replace that which flows out in froth. When the fermentation ceases and the liquor has become vinous, the barrel should then be closed and stored in a cool cellar. In twelve months it is fit for bottling.

**MEAL.** The flour and bran of corn in the mixed state; they proceed from the mill before they are separated by a bolter or dressing machine.

**MEASURE.** A quantity assumed at pleasure, and considered as unity, or one, to which the ratio of other quantities being determined, their relative magnitude, both to the assumed unit, and to each other, will be known. The quantity assumed as unity, is called the measuring unit. Thus, to measure any proposed line, we assume a line of an inch, a foot, a yard, &c., as the measuring unit; suppose this to be an inch; then as many times as it is contained in the proposed line, so many inches will that line be in length. If the proposed line be less than the measuring unit, whatever part that line is of the measuring unit, the same part of an inch will the measure of that line be, and the like of feet, yards, &c. To measure a superficies, a square whose sides are an inch, a foot, a yard, &c. is the measuring unit; and as many times as this is contained in, or contains the given superficies, such will be the measure of that superficies, as was shown in the line. To measure a solid, a cube whose lineal side is an inch, a foot, a yard, &c., is assumed as the measuring unit; and as many times as this unit is contained in, or contains the given solid, so many cubic inches

feet, yard, &c., or parts of one of them, will the proposed solid be. The measure for lines or length is termed *lineal* or long measure: that for surfaces *superficial* measure; and that for solids or capacities, cubic or solid measure.

In 1825 a Bill was passed through Parliament for altering weights and measures previously in use, the preamble of which states, "whereas it is necessary for the security of commerce, and for the good of the community, that weights and measures should be just and uniform: and whereas notwithstanding it is provided by the Great Charter, that there shall be but one measure and one weight throughout the realm, and by the treaty of union between England and Scotland, that the same weights and measures should be used throughout Great Britain, as were then established in England; yet different weights and measures, some larger, and some less, are still in use in various places throughout the United Kingdom of Great Britain and Ireland, and the true measure of the present standard is not verily known, which is the cause of great confusion and of manifest frauds; for the remedy and prevention of those evils for the future, and to the end that certain standards of weights and measures should be established throughout the United Kingdom of Great Britain and Ireland, the new standards are denominated *imperial*, and the rationale of the system by which they have been determined is thus explained. Take a pendulum which will vibrate seconds in London, on a level of the sea, in a vacuum: divide all that part thereof which lies between the axis of suspension and the centre of oscillation into 39·1393 equal parts; then will ten thousand of those parts be an imperial inch; 12 whereof make a foot, and 36 whereof make a yard.

The *standard yard* is determined to be, "that distance between the centres of the two points in the gold studs in the straight brass rod, now in the custody of the clerk of the House of Commons, wherein the words and figures 'Standard Yard, 1760,' are engraved, which is declared to be the genuine standard of the measure of length called a yard;" and as the expansibility of the metal would cause some variation in the length of the rod in different degrees of temperature, the act determines that the brass rod in question shall be of the temperature of 62° Fahr. The measure is to be denominated the "Imperial Standard Yard," and to be *the only standard whereby all other measures of lineal extension shall be computed*. Thus the foot, the inch, the pole, the furlong, and the mile, shall bear the same proportion to the imperial standard yard as they have hitherto borne to the yard measure in general use. And should it happen that the aforesaid brass rod of 1760 be lost, defaced, or destroyed, a reference to the invariable natural standard afforded by the pendulum before mentioned, will enable it to be restored with the utmost exactness.

The *standard gallon* is determined by the act to be such measure as shall contain 10 lbs. avoirdupois weight, of distilled water, weighed in air, at the temperature of 62° of Fahr., the barometer being at 30 inches, to be used as well for wine, beer, ale, spirits, and all sorts of liquids, as for dry goods, not measured by heaped measure; and that all other measures shall be taken in parts or multiples of the said imperial standard gallon, the quart being the fourth part of such gallon, and the pint one-eighth part; two such gallons making a peck, eight such gallons a bushel, and eight such bushels a quarter of corn, or other dry goods not measured by heaped measure."

*Heaped measure*.—"That the standard measure of capacity for coals, lime, culm, fish, potatoes, or fruit, and all other goods, and things commonly sold by heaped measure, shall be the aforesaid bushel, containing 80 lbs. avoirdupois of water, as aforesaid, the same being made round with a plane and even bottom, and being 19½ inches from outside to outside of such standard measure as aforesaid:" and goods thus sold by heaped measure shall be heaped "in the form of a cone, such cone to be of the height of at least six inches, the outside of the bushel to be the extremity of the base of such cone;" three such bushels shall be a sack, and twelve such sacks shall be a chaldron.

*Stricken measure*.—The last-mentioned goods may be sold either by the heaped measure or by the standard weight (see the article WEIGHT); but for all other kind of goods not usually sold by heaped measure, which may be sold or agreed for by measure, the same standard measure shall be used, but it shall not be heaped,

but stricken with a round stick or roller, straight, and of the same diameter from end to end.

The following tables, which are in accordance with the new standard, will be proper to insert in this place:—

*Measures of Length.*

12 inches	are equal to	1 foot.
3 feet	=	1 yard.
5½ yards	=	1 rod or pole.
40 poles	=	1 furlong.
8 furlongs	=	1 mile.
69 <sup>1</sup> / <sub>13</sub> miles	=	1 degree of a great circle of the earth.

An inch is the smallest lineal measure to which a name is given, but mechanics subdivide it generally into eighths and sixteenths; measures or "rules" are however constructed by the rule-makers with every possible variety of subdivisions or scales of the parts of an inch that can be required by artificers, engineers, and scientific persons.

The following particular measures of length are in general use:—

1 nail	=	2½ inches	} used for measuring cloth.
1 quarter	=	4 nails	
1 yard	=	4 quarters	
1 ell	=	5 quarters	
1 hand	=	4 inches . . .	used for measuring the height of horses.
1 fathom	=	6 feet . . . .	used in measuring depths.
1 link	=	7 <sup>99</sup> / <sub>100</sub> inches	} used in measuring land, to facilitate computation of the contents, 10 square chains being equal to an acre.
1 chain	=	100 links	

*Measures of Surface.*

144 square inches	are equal to	1 square foot.
9 square feet	=	1 square yard.
30½ square yards	=	1 perch or rod.
40 perches	=	1 rood.
4 roods or 160 perches	=	1 acre.
640 acres	=	1 square mile.

*Measures of Solidity.*

1728 cubic inches	=	1 cubic foot.
27 cubic feet	=	1 cubic yard.

*Imperial Measures of Capacity.*

4 gills	=	1 pint	=	34½ cubic inches nearly.
2 pints	=	1 quart	=	69½ "
4 quarts	=	1 gallon	=	277½ "
2 gallons	=	1 peck	=	554½ "
8 gallons	=	1 bushel	=	2218½ "
8 bushels	=	1 quarter	=	10½ cubic feet nearly.
5 quarters	=	1 load	=	51½ "

The foregoing measures are used for all liquids, and for all dry goods, except corn, lime, fish, potatoes, fruit, and other goods commonly sold by heaped measure.

2 gallons	=	1 peck	=	704 cubic inches nearly.
8 gallons	=	1 bushel	=	2815½ "
3 bushels	=	1 sack	=	4 <sup>99</sup> / <sub>100</sub> cubic feet nearly.



A knowledge of the comparative value of English and French measures being indispensable to every scientific reader, we add the following calculation of them by Dr. Duncan, jun. :—

1. *French Measures of Length, the metre being at 32°, and the foot at 62°.*

Millimetre	=	.03937	English inches
Centimetre	=	.39371	"
Decimetre	=	3.93710	"
Metre	=	39.37100	"
Decametre	=	393.71000	"
Hecatometre	=	3937.10000	"
Kilometre	=	39371.00000	"
Myriometre	=	393710.00000	"

2. *French Measures of Capacity.*

Millilitre	=	.06103	English cubic inches.
Centilitre	=	.61028	"
Decilitre	=	6.10280	"
Litre	=	61.02800	"
Decalitre	=	610.28000	"
Hecalitre	=	6102.80000	"
Kilolitre	=	61028.00000	"
Myriolitre	=	610280.00000	"

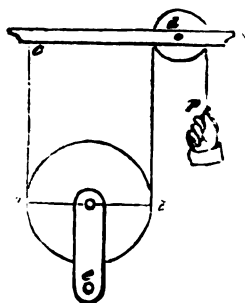
For the comparative value of English and French measures of weight, see **WEIGHT**.

**MECHANICS** is a science which treats generally of the action of forces on solid bodies, and the construction and use of machinery. When forces acting upon a body in different directions produce equilibrium, it is investigated under the head of **STATICS**; but when the acting forces are so applied as to produce motion, it constitutes a case in **DYNAMICS**, which see.

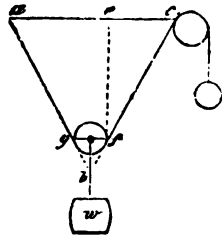
**MECHANIC POWERS** are those simple machines or elements that enter into the construction of the various parts of machinery: they are usually considered to be six in number; viz. the lever, the wheel and axle, the pulley, the inclined plane, the wedge, and the screw. It may be easily shewn, however, that these are capable of being reduced to greater simplicity. Thus the wheel and axle is only a succession of levers, and the wedge and screw are merely modifications of the inclined plane; hence all the varieties of machinery are reduced to these three simple elements:

1. The lever.
2. The pulley.
3. The inclined plane.

In treating of the use of simple machines, it is usual to consider all bars as perfectly inflexible, cords as perfectly flexible, and surfaces to move on each other without friction, and afterwards to make allowances for these disturbing forces to the weight raised, as 1 to 2. In the diagram,  $a e b$  is the movable pulley supporting the weight at  $e$ ;  $c a e b p$  is a cord passing under the movable pulley, and over the fixed pulley at  $d$ . Now, as the whole weight is supported by the two portions of the cord  $c a$  and  $d b$ , each of them sustains one half, and as the passage of the cord over the fixed pulley makes no difference in the proportion, it is clear that the power  $p$  is equal to half the weight.

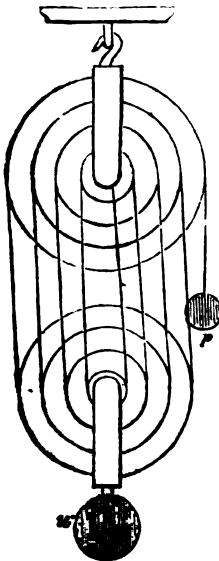


When the cords are not parallel, as in the annexed diagram, the angle made by the cords with the perpendicular must be noticed. Thus the force acting in the direction  $fc$  must be resolved into two others, one pulling in the direction  $ec$ , and the other in  $fe$ . Now the force in  $ec$  does not all act in supporting the weight, which is wholly sustained by that in  $fe$ : hence the power is to the weight as  $cf$  is to twice  $ef$ ; and as  $cf$  is greater than  $ef$ , the power must be greater than one-half the weight, and, consequently, there is a loss of power by the obliquity of the cords. Sometimes the lower or movable pulley consists of a block containing several small wheels or sheaves, in which case the apparatus is termed a block and fall. The power with such a pulley is easily calculated, by observing the number of cords by which the lower block or fall is supported. If the fall be suspended by six ropes, of course each will sustain one-sixth of the weight, and the power will be to the weight as 1 to 6. In every combination of this kind, therefore, the power is to the weight as 1 to the number of cords supporting the lower block, or as 1 to twice the number of sheaves in the fall.

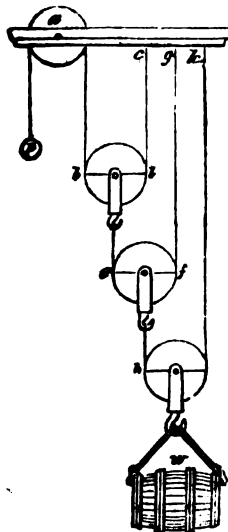


A modification of this arrangement is seen in the following diagram (*Fig. 1*), of White's pulley: it consists of a number of concentric grooves, formed in a solid mass of brass, &c., the diameters of the grooves being regulated by the quantity of cord that has to pass over each. As these all move on a single axis, considerable reduction of friction is obtained; but the great difficulties

*Fig. 1.*



*Fig. 2.*



attending the construction of this apparatus seem insuperable obstacles to its extensive employment. The power is calculated as in the last example. In the different arrangements hitherto mentioned, a single cord is employed passing round all the pulleys; and if attention be given to the spaces passed over by the part attached to the power and that affixed to the weight, it will be

seen that the same law obtains as in the other mechanic powers,—the space passed over by the power exceeding that passed over by the weight, as much as the weight exceeds the power.

In this arrangement different cords are employed (as in *Fig. 2* in the preceding page), one to each pulley; there being three movable pulleys, the power is to the weight as 1 to 8: thus suppose the power to be 1 lb., the cords *a b* and *c l* will each support 1 lb.; hence the cords supporting the pulley *e f* will each sustain 2 lbs., and the cords supporting *h i* will each bear 4 lbs. Or, suppose the weight to be sustained by the cord *k i h*, each will support one-half; the cord *g f e* will support one-fourth, and *c l b* will sustain one-eighth. In movable pulleys, then, with separate cords to each pulley, the power is to the weight as the number 2 raised to a power equivalent to the number of pulleys employed. If the number of pulleys had been four, the power gained would have been  $2 \times 2 \times 2 \times 2 = 16$ .

Another combination, somewhat similar, is seen in the next figure (*Fig. 1*), in which the several cords are attached to the weight; this makes a little difference in the amount of power gained. A power *p* of 1 lb. will sustain a part of the weight equal to 1 lb. This power of 2 lbs. acting at *d*, will support an equal portion of the weight, which, again acting with double force at *g*, will sustain 4 lbs.; hence the quantity supported is  $1 + 2 + 4 = 7$  times the power.

Fig. 1.

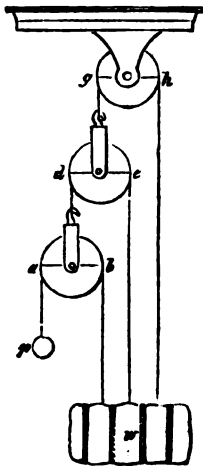
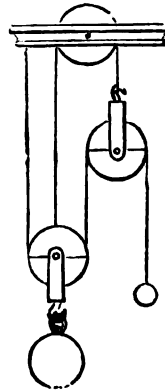


Fig. 2.



Another somewhat different arrangement is shown in *Fig. 2*, in which the one cord passes over a fixed, and the other, over one of the movable pulleys. A power of 1 lb. at *p* would support a weight of 2 lbs. at *w*, and an equal advantage is gained by the attachment of the cord passing over the fixed pulley *a*; the power is therefore one-fourth of the weight. Other combinations sometimes occur, the nature of which will, it is presumed, be understood by reference to those above explained.

**MEPHITIC** is a term often applied to carbonic acid.

**MERCURY** is a metal distinguished from all others by its extreme fusibility, which is such that it does not take the solid state until it is cooled to the  $39^{\circ}$  below 0 in Fahrenheit's thermometer, and is therefore always fluid in the temperate climates of the earth. From this circumstance, and its resemblance to silver in colour and metallic splendour, it has been usually denominated *quick-silver*. The term *mercury*, although almost universally employed by chemical authors, is strongly objected to by Mr. Gray, the author of *The Operative*

*Chemist*, who complains that "medical authors and chemists of the medical professions, still continue to call this metal (which he denominates *quicksilver*) *mercury*, that name having been formerly used by the priest-physicians and priest-chemists, to mystify and hoax their patients and the public. It were to be wished that now chemistry and medicine are almost exclusively in the hands of the laity, they would abstain from this ridiculous mummery." The same author also informs us that there are two kinds of quicksilver in the market,—Spanish and Austrian, both of which are very pure; and that "the source of the impure quicksilver in the apothecaries' shops, is the purchase of the *quicksilver* from the silversmiths of bankrupt or deceased looking-glass makers, which is of course impregnated with tin, and sometimes lead and bismuth; this quicksilver is cheaper than the pure, and is thought by them good enough for making blue pill and blue ointment." Mr. Gray does not, however, censure this pernicious practice of the laity, notwithstanding he is so indignant at the presumed alteration of a mere term of doubtful propriety by our learned forefathers. The specific gravity of mercury is at 212° Fahr. 13.375; at 160°, 13.580, and at 40° below zero it increases to 15.632, when it is a malleable solid body. It is volatile, and rises in small portions at the common temperatures of the atmosphere, as is evinced by several experiments, more especially in a vacuum, such as obtains in the upper part of a barometer tube. At the temperature of 650° it boils rapidly, and rises copiously in fumes: it has been attempted to employ the mechanical force which it then exerts as a motive power similar to that of the steam engine; but the loss of the metal, by the extreme subtlety of the vapour passing apparently impervious joints, occasioned, we are informed, its abandonment. Mercury is sometimes found native, but generally combined with sulphur, when it is denominated cinnabar; it is separated from the sulphur by distillation with quicklime or iron filings. Owing to the property which mercury possesses of dissolving completely some of the baser metals, it is extremely liable to adulteration; and the union of the metals is so strong, that they even rise with the quicksilver when distilled. The impurity of mercury is generally indicated by its dull aspect; by its tarnishing and becoming covered with a coat of oxide on long exposure to the air; by its adhesion to the surface of glass; and when shaken with water in a bottle, by the speedy formation of a black powder. Lead and tin are frequent impurities, and the mercury becomes capable of taking up more of these if zinc or bismuth be previously added. In order to discover lead, the mercury may be agitated with a little water, in order to oxidize that metal; pour off the water and digest the mercury with a little acetic acid: this will dissolve the oxide of lead, which will be indicated by a blackish precipitate with sulphuretted water; or to this acetic solution, add a little sulphate of soda, which will precipitate a sulphate of lead, containing, when dry, 72 per cent. of metal. If only a very minute quantity of lead be present in a large quantity of mercury, it may be detected by solution in nitric acid, and the addition of sulphuretted water. A dark brown precipitate will ensue, and will subside, if allowed to stand a few days; one part of lead may thus be separated from 15,263 parts of mercury. Bismuth is detected by pouring a nitric solution, prepared without heat, into distilled water; a white precipitate will appear if this metal be present. Tin is manifested in like manner by a weak solution of nitro-muriate of gold, which throws down a purple sediment; and zinc, by exposing the metal to heat. When the metallic mixtures contain a sufficient quantity of mercury to render them soft at a mean temperature, they are called amalgams. Although it is obvious, from the known inferior specific gravity of iron, lead, and silver, that pieces of these metals will float in mercury, like wood in water, it nevertheless forms a very interesting phenomenon. Mercury is readily soluble in acids, as may easily be ascertained; and from its very extensive use in medicine, there are very numerous preparations of it, by which it may be exhibited in powders, pills, or drops. The most usual is calomel, which is a preparation of mercury and muriatic acid, or chlorine, and is hence called, according to the modern nomenclature, protochloride of mercury. The deuto-chloride, or corrosive sublimate, is another combination of mercury and chlorine, and forms one of the most powerful and

useful, but dangerous medicines, man has ever discovered. Mercury will readily unite with sulphur. Melt some sulphur in a crucible on the fire, then add a little mercury, and stir the whole well together, and a sulphuret of mercury, or cinnabar, will be formed. That beautiful scarlet pigment called vermilion (see the separate article) is also prepared from mercury and sulphur, and is called by chemists the red sulphuretted oxide of mercury. The property of mercury dissolving a certain portion of gold and silver, enabled alchemists to impose upon mankind, and make it appear as if they had succeeded, in a small degree, in discovering the secret of turning metals into gold and silver. In their operations they employed mercury in which small portions of these metals had been dissolved; and as the mercury was evaporated by great heat, and left the gold and silver behind, the bye-standers were made to believe that these metals had actually been produced in operation by the skill of the experimentalist. Looking-glasses and mirrors are covered on the back with an amalgam of tin, and the glasses are afterwards loaded with weights, to press out gradually the superfluous mercury, which thus exudes from the amalgam. Amongst the numerous uses of this valuable metal, the application of it in the construction of barometers and thermometers is not the least important. See those inventions.

**METALLURGY**, in a general sense, comprehends the art of working metals from the state of ore to the utensil; and in this sense, assaying, smelting, refining, smithery, &c., are branches of metallurgy. In a more limited sense, however, it includes only the separation of metals from their ores, or other combinations. Few metals are found in a pure state; gold, silver, and copper are sometimes exceptions; the other metals are generally found in the state of ores, in which they are mixed and blended with other substances, so as not to have the ductility, lustre, or other qualities of metals. Sometimes the ore is only a pure oxide, and requires but the abstraction of the oxygen, by fusion with inflammable substances. The ores of metals are always separated from the rocks on each side by a quantity of spar, quartz, or sometimes softer clay or earth, called the matrix or rider. The first operation in metallurgy is to separate the ore from the matrix; but when the ore is found in large masses, most of it can be obtained by the miner's implements free from the matrices, and those portions that adhere are knocked off by hammers. In other cases, when the ore is intimately mixed with the matrix, it becomes necessary to resort to different processes, such as roasting, pounding, and washing; the latter operation effecting the separation by the difference of specific gravity of the mixed matters; the earthy parts being floated away, leaving the metallic portion behind. See the following article.

**METALS**. A numerous class of undecomposed bodies, which are distinguishable by their lustre, ductility, malleability, tenacity, opacity, &c. They are fusible by heat, and in fusion retain their lustre and opacity; and they are all, except selenium, excellent conductors, both of electricity and caloric. When they are exposed to the action of oxygen, chlorine, or iodine, at an elevated temperature, they generally take fire, and combining with one or other of these three elementary dissolvents, in definite proportions, are converted into earthy or saline-looking bodies, devoid of metallic lustre and ductility, called oxides, chlorides, or iodides. They are capable of combining in their melted state with each other, in almost every proportion, constituting the important order of metallic alloys. From their brilliancy and opacity conjointly, they reflect the greater part of the light which falls on their surface, and hence form excellent mirrors. "The relations of the metals to the various objects of chemistry," Dr. Ure observes, "are so complex and diversified as to render their classification a task of peculiar difficulty. I have not seen any arrangement to which important objections may not be offered; nor do I hope to present one which shall be exempt from criticism. The main purposes of a methodical distribution are to facilitate the acquirement, retention, and application of knowledge. With regard to metals in general, I conceive these purposes may be to a considerable extent attained, by beginning with those which are most eminently endowed with the characters of the genus, which most distinctly possess the properties that constitute their value in common life, and which caused the early inhabitants of the earth

GENERAL TABLE OF THE METALS, BY DR. URE.

NAME.	SPECIFIC GRAVITY.	PRECIPITANTS.	COLOUR OF PRECIPITATES BY			
			Potassium of Potash.	Ammonia of Salts.	Sulphur.	Hydro-sulphuric.
1. Platinum	21.47	Mur. ammonia	.....	.....	.....	Black met. powd.
2. Gold	19.30	{ Sulph. iron Nitr. mercury	Yellowish white	Green; met.	.....	Yellow.
3. Silver	10.45	Common salt	White	Yellow-brown	.....	Black.
4. Palladium	11.8	Prussiate mercury	Deep orange	Orange-yellow	.....	Black-brown.
5. Mercury	13.6	Common salt	White passing to yellow.	Brown	.....	Black.
6. Copper	8.9	Iron	Red-brown.	{ Protoc. O Peroc. Black	.....	Ditto.
7. Iron	7.7	Saccin. soda, with peroxide..	Blue, or white passing to blue.	.....	.....	..... O.
8. Tin	7.29	Corro. sublimate	White	.....	{ Protoc. black. Peroc. yellow. }	Brown.
9. Lead	11.35	Sulph. soda	Ditto	White	.....	Black.
10. Nickel	8.4	Sulph. potash	Ditto	Grey-white	.....	..... O.
11. Cadmium	8.6	Zinc	Ditto	.....	.....	Orange-yellow.
12. Zinc	6.9	Alk. carbonates	Ditto	.....	.....	Yellowish-white.
13. Bismuth	9.88	Water	Ditto	Yellow	.....	Black-brown.
14. Antimony	6.70	{ Zinc Water	With dilute solutions, white..	White from water	.....	Orange.
15. Manganese	8.	Tarr. potash	White	.....	.....	White
16. Cobalt	8.6	Alk. carbonates	Brown-yellow	Yellow-white	.....	Milkiness.
17. Tellurium	6.15	{ Water Antimony	.....	.....	.....	..... O.
18. Arsenic	{ 8.35 5.76 }	Nitr. lead	White	Yellow	.....	Yellow.
19. Chromium	5.99	Ditto	Green	Brown	.....	Green
20. Molybdenum	8.6	Ditto	Brown.	Deep-brown	.....	Brown.
21. Tungsten	17.4	Mur. lime?	Dilute acids	Orange	.....	.....
22. Columbium	5.61	Zinc, or inf. galls	Olive	.....	.....	Chocolate
23. Selenium	4.81	{ Iron Sulph. ammonia	.....	.....	.....	.....
24. Osmium	?	Mercury	.....	Purple passing to deep blue.	.....	.....
25. Rhodium	10.65	Zinc?	.....	.....	.....	..... O
26. Iridium	18.68	Ditto?	.....	.....	.....	.....
27. Uranium	9.9	Ferro-prus. potash	Brown-red	Chocolate	.....	Brown-yellow
28. Titanium	?	Infusion galls.	Green-grees	Red-brown	.....	Grass-green
29. Cerium	?	Oxal. amm.	Milk-white	.....	.....	White
30. Potassium	0.865	{ Mur. plat. Tar. acid	.....	.....	.....	..... O

to give to the first metallurgists a place in mythology. Happy had their idolatry been always confined to such real benefactors! By arranging metals according to the degree in which they possess the obvious qualities of unalterability, by common agents, tenacity, and lustre, we also conciliate their most important chemical relations, namely, those to oxygen, chlorine, and iodine; since their metallic pre-eminence is, popularly speaking, inversely as their affinities for these solvents. In a strictly scientific view, their habitudes with oxygen should perhaps be less regarded in their classification than with chlorine, for this element has the most energetic attraction for the metals. But, on the other hand, oxygen, which forms one-fifth of the atmospheric volume, and eight-ninths of the aqueous mass, operates to a much greater extent among metallic bodies, and incessantly modifies their form, both in nature and art. Now the order we propose to follow will indicate very nearly their relations to oxygen. As we progressively descend, the influence of that beautiful element progressively increases. Among the bodies near the head, its powers are subjugated by the metallic constitution; but among those near the bottom, it exercises an almost despotic sway, which Volta's magical pile, directed by the genius of Davy, can only suspend for a season. The emancipated metal soon relapses under the dominion of oxygen." This table is given at page 143.

The first 12 metals are malleable, and so are the 30th, 31st, and 32d, in their congealed state. The first 16 yield oxides, which are neutral salifiable bases. The metals 17, 18, 19, 20, 21, 22, and 23, are acidifiable by combination with oxygen. Of the oxides of the rest, up to the 30th, but little is known. The remaining metals, sodium, lithium, calcium, barium, strontium, magnesium, yttrium, glucinum, aluminium, thorium, zirconium, and silicium, form, with oxygen, the alkaline and earthy bases.

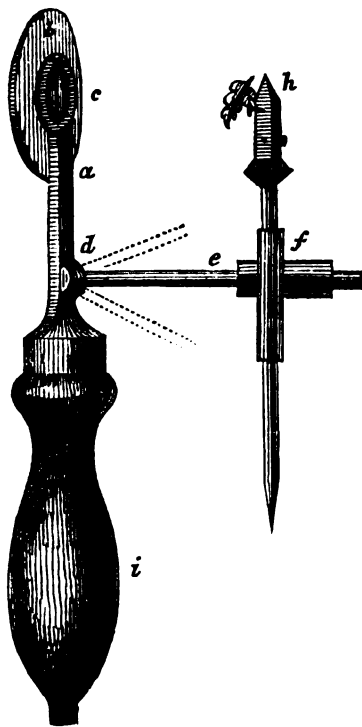
**MICA.** A mineral, which Professor Jameson divides into ten species; but the term is generally understood to imply talc, or Muscovy glass, which is one of the species. Most of the mica or talc of commerce is brought from Siberia, where it is used as a substitute for window-glass. In this country it is employed for similar purposes where violent agitation or great heat would be destructive of common glass. It is also used for enclosing objects for microscopes, for which it is admirably adapted; consisting, as it does, of an unlimited series of transparent laminae adhering to each other, which easily separate into extremely thin flexible plates, by the application of the fine edge of a pen-knife.

**MICROMETER.** An instrument of which there are various constructions, usually applied to telescopes and microscopes, for the purpose of measuring minute bodies, or small angles formed by bodies at a remote distance, by which their real magnitude is obtained. To the modern introduction of this instrument for the use of the astronomer, and to the improvement of the telescope, may be attributed our present accurate and extensive acquaintance with the universe of matter; while, from the perfection to which the microscope has been brought, an equal acquaintance with the organization of minute bodies may be expected. By the application of the micrometer to the latter instrument, the power of the naturalist is materially extended; while the micrometer is of the utmost value for trigonometrical surveys, and in military and naval operations.

**MICROSCOPE;** from two Greek words, signifying *small*, and *to view*. An optical instrument for viewing small objects, rendering those visible which cannot be distinguished by the naked eye, and magnifying those that can. The forms of microscopes are very numerous, but they may all be included in three distinct classes, namely, *single*, *compound-refracting*, and *compound-reflecting* microscopes. A simple, or single microscope, is that which consists of a single lens or single spherule. Most persons may have observed, that when the distance of an object is decreased, we are enabled to define its parts more readily, and that it appears larger; thus, if we look at two men, the one at 200 feet, and the other at only 100 feet from us, the former will appear only half the height of the latter; or the angle which the latter forms with the eye of the observer will be twice that of the former. Hence the nearer we can bring an object to the eye, the larger it will appear. If we have to examine a very minute object, and in order to render its parts distinguishable, if we bring it

very near to the eye, (suppose one or two inches,) it will become very indistinct and confused. This effect is produced by the great divergency of the rays of light from the object, and the power of the crystalline lens of the eye not being sufficient to collect the rays, whereby an image of the object may be formed on the retina, at the proper distance at the back of the eye. But if we employ a single microscope, which consists of a convex lens, usually made of glass, (though it would have the power of magnifying or increasing the angle, if made of any other transparent substance, but in a different degree,) mounted or fixed in brass, and place it between the object and the eye, the former being in the focus of the glass, the diverging rays from the object will be refracted and rendered parallel by the lens, and we shall thus obtain a near and distinct view of the object. The quantity of light necessary to be employed in using a microscope is dependant on the nature of the object under examination, and on the magnifying power of the lenses necessary for its development.

The annexed figure is a single microscope; *a* is the brass stem; *c* the cell containing the lens; at *d* there is attached an arm *e*; this arm, being jointed at *d*, is capable of lying flat, or being altered to any convenient position for viewing the object, as shown by the dotted lines; on the round arm *e* is a sliding tube *f*, fixed to another tube at right angles, which carries the forceps *h*, movable in every direction with respect to the lens *c*; the handle *i* is screwed to the stem *a* when in use. This is the most convenient form of a single microscope.

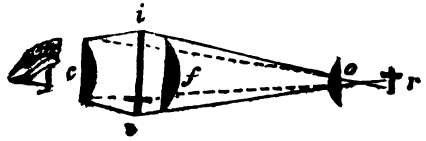


A *compound refracting Microscope* is an instrument consisting of two or more convex lenses, by one of which an enlarged image of the object is formed, and then by means of the other, employed as an eye-glass, a magnified representation of the enlarged image is obtained. The distance at which the two lenses of a compound microscope are placed from each other must always exceed the sum of their focal lengths, in order that the image may be formed by the object-glass in the exterior focus of the eye-glass. The great distinction between single and compound microscopes is, that in the latter we only view a magnified *image* of the object, while in the former we see the *object itself*. From this it must be evident,

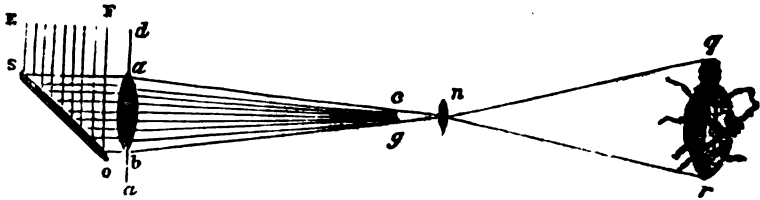
that unless the image formed by the object-glass be a perfect representation of the object in every particular, its imperfections, however small, will be increased by the eye-glass, in the same ratio as it magnifies the image. On account of this disadvantage, the compound microscope had been entirely laid aside by the most distinguished naturalists and philosophers till very lately. For general purposes it is preferred, on account of the extent of field obtained by it, which is far greater than that obtained by ordinary single glass lenses of equal power. For these purposes, there is usually introduced a third, or field-glass, by which the extent of view is still further increased by the rays being bent by this lens, so that a greater portion of them may be refracted by the eye-



glass. The annexed figure is a section of a compound microscope;  $r$  is the object intended to be magnified, which is placed in the focus of the object-glass  $o$ ; by this lens, an enlarged and inverted image is formed at  $i$ , in the focus of the eye-glass  $c$ ;  $f$  is a field-glass, by which the extent of the view is increased from the diverging dotted lines to  $i$ , by the rays being bent by this lens, so that a greater portion of them is refracted by the eye-glass  $c$ .



*The Solar Microscope* consists of a common microscope, connected to a reflector and condenser, the former being used to throw the sun's light on the latter, by which it is condensed to illuminate the object placed in its focus. This microscope is sometimes called the Camera Obscura Microscope, but it still more nearly resembles the magic lantern in its effect. The exhibition it affords is made in a darkened room, and it can only be used when the sun shines. This instrument usually consists of one plane mirror and two lenses. The mirror  $so$  must be without the window shutter  $qu$ ; the lens  $ab$  fixed in the shutter; and the lens  $n$  within the room. The lens  $ab$  is inclosed in a brass tube, and the other in a smaller tube, which slides in the former, for the purpose of adjusting it to the proper distance from the object. The mirror can be so turned by adjusting screws, that however obliquely the incident rays  $E F$  fall upon it, they can be reflected into the dark room through the illuminating lens  $a b$  in the shutter. This lens collects those rays into a focus near the object, and, passing on through the object  $cg$ , they are met by the magnifier  $n$ ; here the



rays cross, and proceed divergently to a vertical white screen prepared to receive them; on which screen, the image or shadow  $qr$  of the object will appear. The magnifying power of this instrument depends on the distance of the white screen, and in general bears a certain proportion to the distance of the object  $cg$  from the magnifier  $n$ ; that is, if the screen be at ten times that distance from the lens  $n$ , the image will be ten times as long, and ten times as broad as the object. About ten or twelve feet is the best distance; for, if further off, the image, though larger, will be obscure and ill defined. The apparent magnitude of objects is measured by the angle under which they are seen by the eye, and those angles are reciprocally as the distances from the eye. If eight inches be assumed as the nearest limit of a distinct vision to the naked eye, and by interposing a lens, we can see with equal distinctness at a nearer distance, the object will appear to be as much larger through the lens than to the naked eye, as its distance from the eye is less than the distance of unassisted vision. If the focal distance of a convex lens be one quarter of an inch, or the thirty-second part of the common limit of vision, or eight inches, the lineal dimensions of an object examined with it will be magnified thirty-two times, and its surface 1024 times, or the square of 32.

The simplest microscope which can be employed to any useful purpose, is that which is made with a drop of water, suspended in a very small hole in a thin slip of brass, or any similar material. A spherule of water, however, of

the same size as one of glass, will not magnify so much as the latter, because, as its density is not so great, it has a longer focus. A drop of water placed on the end of a slender piece of brass wire, and held to the eye by candle-light, will, without any other apparatus, magnify, in a very surprising manner, the animalculæ contained in it. These water microscopes have given rise to the use of various other fluids, with several varieties of construction. Dr. Brewster, instead of water, has made use of very pure and viscid turpentine, taken up by the point of a piece of wood, and dropped successively upon a thin and well-polished glass. The same gentleman has also used sulphuric acid and castor-oil, both of which possess a refractive power considerably greater than water. Fluid lenses have been employed as the object-glasses of compound microscopes. Minute glass spherules make excellent microscopes, but the foci of the smallest sort are so short, that it requires considerable attention and patience to employ them well.

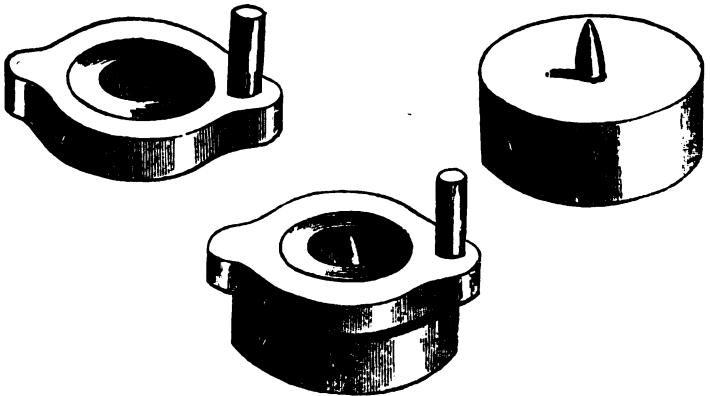
**MILK.** A fluid secreted by the females of the class *mammalia*. Although the proportions of its constituents vary in different animals, its general properties are the same in all. When this fluid is allowed to stand for some time, it undergoes spontaneous changes, and is resolved into its component parts: a thick yellowish substance collects on the surface, which is *cream*, while the milk beneath becomes thinner than before, and is of a pale bluish colour. When cream is kept for some days without being disturbed, it gradually becomes thicker, till at last it acquires the consistence of cheese; so that one method of making cream cheese is merely by putting cream into a linen bag, and leaving it there till it becomes solid. When cream is shaken, it is resolved into its component parts. The process by which this is accomplished is called churning, whence two products result,—*butter* and *butter-milk*. In the making of butter, cream is allowed to stand for some time, during which an acid is generated. It is then put into a churn and agitated, by which the butter is gradually separated; what is left (the butter-milk) has a sour taste, but not so much as that of the cream before churning. Butter is also sometimes made from cream which has not become sour, but the process is much more tedious, owing to the want of acid to favour the separation. Butter is merely an animal oil, solid at a natural heat, but held in solution, in milk, by some of the other substances; thus obtained, however, the butter is not pure, and requires much washing in water to free it from its impurities, and, by the subsequent addition of salt, it may be kept good a long time. Milk from which butter has been taken undergoes spontaneous changes; it becomes much sourer, and assumes a gelatinous form. When heated, the fermentation of this coagulum is hastened, and, by the addition of certain substances, it very soon takes place; thus acid and spirits of wine curdle it, which is owing to the albumen it contains being acted upon by them in the same way as blood or white of eggs. By far the most powerful coagulator, however, is the substance called *rennet*. When the milk is previously heated, and rennet added, it instantly coagulates. If the coagulum be cut, a thinnish fluid oozes from it; and if it is put into a bag and squeezed, the whole of this is forced out, and a whitish tough matter remains; the former is *whey*, and the latter *curd*. On this depends the process of making cheese, which varies in richness according to the mode followed in preparing it. When milk is heated gradually, and merely to the temperature at which it curdles, and the curd freed gently from the whey, it retains almost the whole of the cream, which adds to its richness and flavour; but when it is curdled quickly, and the whey is speedily removed by cutting the curd, a great deal, or nearly the whole of the cream is carried off, and the cheese is poor, and has not the rich flavour of cheese made in the other way. The latter is the method usually followed in Scotland, where both cheese and butter are obtained from milk,—the whey procured in the process yielding a considerable quantity of the latter; and hence the comparative poorness of Scotch cheese. In making cheese, having obtained the curd, and freed it from its whey, the remaining part of the process is merely to subject it to pressure, by which the whole of the whey is forced out; the colouring ingredient is generally annotta, to give it the desired tint.

Milk, according to the analysis of Berzelius, consists of—

	Parts.
Water . . . . .	928.75
Curd, with a little cream . . . . .	28.00
Sugar of milk . . . . .	35.00
Muriate of potash . . . . .	1.70
Phosphate of potash . . . . .	0.25
Lactic acid, acetate of potash with a trace of lactate of iron . . . . .	6.00
Earthy phosphates . . . . .	.30
	1000.00

The same chemist found cream of spec. grav. 1.0244, by analysis to consist of butter 4.5, cheese 3.5, whey 92.

MILLS are machines for triturating all kinds of substances capable of being reduced or pulverized by their action. Those employed for converting grain into flour, by rubbing it between two hard surfaces, are generally of stone. The earliest species of mills were of a very rude and simple construction, consisting of two flat stones, one placed on the other, and the uppermost turned by hand, resembling the figures shown in the following engraving, which represents a hand-mill in



nearly universal use at the present day amongst the eastern countries. The two stones are put together, as in the figure, and the upper one is then turned by hand round the central pivot. Mills of this description were in common use amongst the Egyptians, Hebrews, Romans, and other nations of antiquity, and continued in use in the Highlands of Scotland until a very recent date; the *principle* is indeed the same as that of our most modern and improved mills, but it is only adapted for grinding small quantities of grain at a time.

Under the head HAND-MILLS we have described two mills, which were designed to illustrate a mode of applying manual power to such machines, that has been deemed by various eminent writers on mechanics as the most efficient; namely, that of *rowing*. But however energetic that action may be, it does not appear to have stood the test of experience; probably on account of it not being so convenient at all times as that of the winch, which is, besides, much more compact, and requires for its use no previous initiation. The ordinary kind of small hand-mills resemble closely those metallic coffee-grinders which almost every person has in his possession, or may see in constant requisition in the shops of grocers. A few words will describe the whole of this class.—They

consist of one central solid frustrum of a cone, the outer circular surface of which is cut spirally into furrows, so as to present at the upper edges of the latter a continuous series of angular teeth. On the outside of the latter is fixed concentrically a hollow frustrum of another cone, similarly cut into grooves, and so proportioned to the former, that at one extremity the opposed grooves almost touch each other, and at the other they are so far apart as to admit the articles to be ground, whole. These concentric conical grinders are fitted up in a variety of ways. In the little box-mills the axes of the cones are usually vertical; but in the fixed, or post-mills, the cones are horizontal: in both, they are surmounted with hoppers to convey the materials to the grinding surfaces, and the products of the trituration are received into either fixed or loose receptacles beneath. By the revolution of the inner cone, the substances are first broken in the widest part of the annular crevice, and being thus reduced in size, they gradually sink, or are forced into narrower and narrower spaces, until they emerge from the grinders in a state more or less comminuted, according to the adjusted space between the grinders, which is usually performed by a screw passing through a traverse bar, with its end bearing against one end of the revolving grinder, so as to limit the extent of its separation or distance from the fixed grinder. Mills constructed upon the same principle are almost universally applied to a great variety of useful purposes; and the manufacture of them is one of considerable extent in Birmingham and other places. But however valuable their application generally, they are but ill adapted to the grinding of corn advantageously, because the perfection of that art consists in an exact separation of the husk, or bran and pollard, from the pure flour; and the operation cannot be successfully performed if the corn be much cut to pieces, which mills of the kind just described almost invariably do when they are in order, or sharp; and when they are dull from wear, the mills soon clog, if set close,—or if set open, a very wasteful quantity of flour is left upon the bran or other offal. These defects arise, in our opinion, from an erroneous mode of construction. Corn and grain generally are extremely solid compact bodies, and when reduced to powder or meal, they occupy a much larger space than previously; consequently, as the grinding progresses, the spaces for the reception of the comminuted matter should be proportionally *enlarged*; but it will be observed, that the annular crevices between the concentric cones, where the grinding takes place, are rapidly *contracted* into a very acute angle. Here the clogging necessarily occurs; and unless the grinders be set considerably wider apart, so as to let the meal pass out in an extremely coarse state, the meal, by the continued attrition (or kneading as it were) becomes converted into a pasty, blackened mass. From a series of experiments made with cones of various inclinations by the writer, evidence, conclusive to his mind, was afforded of this fact, that, in proportion as the concentric cones were reduced in their height, did the flour improve; and, finally, when he brought the surfaces down to a perfect *flat*, the products of the grinding were, in the language of the miller, *more lively*, and of a *better colour*, than in any previous experiments. From the singularly beautiful and ingenious device of concentric conical grinders, and their compactness, it is almost to be lamented that they do not succeed better with wheat. There is, however, another defect attached to these mills, which we ought not to forbear noticing; this consists in the spiral grooves forming a series of continuous cutting edges, which clip the grain to pieces, and cause much of the husk to be ground fine, and be inextricably mixed with the flour; whereas, the action ought to be that of simple crushing, in the first part of the operation, which flattens the husk, and permits the flour to be afterwards rubbed and scraped from its surface, without incurring much subsequent minute subdivision to the detriment of the flour.

A very elegant and compact corn-mill was constructed in France, and was adopted by Buonaparte for the uses of his vast army when he invaded Russia in 1812. Hence it was called the French military mill, and it was introduced subsequently into this country on account of its portability and convenience. It consisted of two circular cast-iron plates, about 12 inches in diameter, placed in a vertical position, one of which was fixed, and the other rotative, upon a

horizontal axis, turned by a winch. The plates were indented all over with radiating grooves; the corn was conducted to the centre, or eye, by means of a lateral hopper, and the meal, as it was ground, was projected from around the periphery by the centrifugal force of the revolving plate.

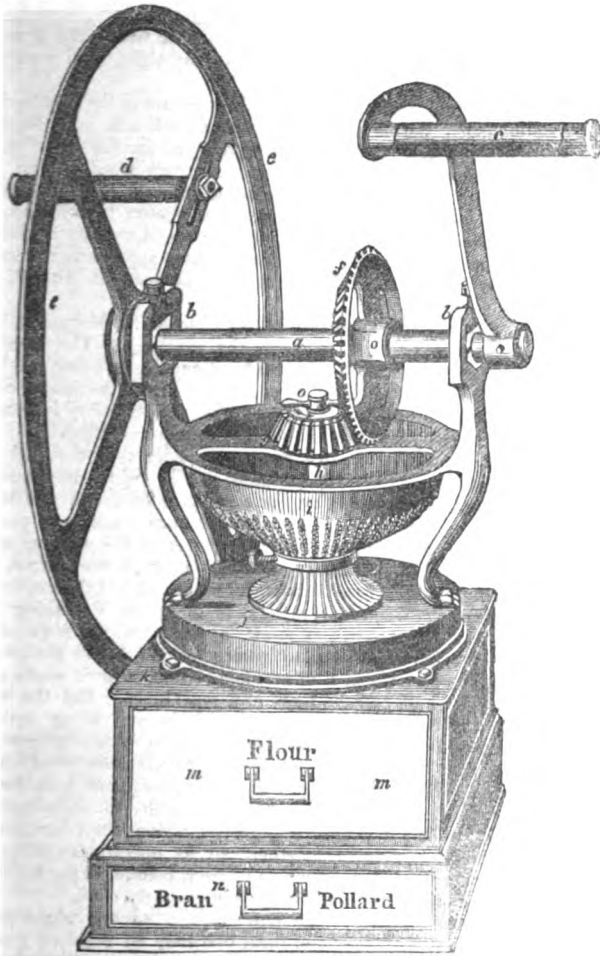
In 1824, Messrs. Taylor and Jones took out a patent for some improved appendages or adjustments to this mill; but there is reason to believe that the undertaking failed from an inherent defect in the construction of the original. The vertical position of the plates is unquestionably disadvantageous, as the effect of gravity is always counteracting the centrifugal action, and necessarily causes a larger portion of the meal to descend from underneath than from the sides or the top; and this tendency, we suspect, must have rendered it expedient to work very close, to prevent the meal dropping out in a coarse state: and from the greater resistance of the meal on the lower side than on the upper, the plates were liable to spring or separate more underneath; or if unyielding, by reason of their solidity and perfect centering, a deterioration of the meal seems to be the necessary result.

Many attempts have been made to grind wheat by stones running vertically, both here and in America, but a little experience in their working has generally led to their abandonment. A variety of machines have, likewise, been constructed for domestic use, wherein the dressing-machine, or bolter, has been annexed to the mill, so that the two processes shall be conducted consecutively within the same framing. Such machines, therefore, represent the apparatus of the great public mills in miniature; but they confer no advantages, because they are equally complex, and are put together in an inferior manner. Viewing the subject in this light, the writer, a few months ago, directed his thoughts to the simplification of the millering apparatus; and he so far succeeded, as to perfectly grind and dress upon the *same* continuous surface, which appears to be the limit of invention, at least as far as the principle is concerned. The following account of this machine is extracted from the *Mechanics' Magazine*, No. 665.

*“Hebert's Patent Flour-making Machine.*—From a personal inspection of the machine delineated in perspective on the following page, and from a careful perusal of the inventor's specification, it appears to us to be his design to construct flour-mills of the utmost simplicity and durability; in which, not only the grinding of the corn, but the dressing (sifting) of the meal into flour, pollard, bran, &c., are simultaneously performed. It is not, however, to be understood that these combined operations are effected by the mere annexation of a dressing-machine to a mill, and driving them both together; for in such an arrangement there would be neither novelty nor economy. But the combined operations of grinding and dressing are in this new patent mechanism so simplified, and so intimate, that they are continuously going on, upon *one continuous surface*. The essential members of the machine are thereby reduced to only *two*! one stationary, the other rotative. This remarkable simplicity conduces to many advantages, which our mechanical readers will at once appreciate, without our entering upon the details. The inventor has shown in his specification, and has actually put into beneficial practice, several modifications of the principle so as to adapt the scale of their operations to any required magnitude. We have selected for the present article what the patentee denominates his patent *domestic* flour-maker, which is adapted to the manual force of one man; but the power requisite to work this may be diminished or increased at the pleasure of the operator, by a corresponding reduction or augmentation of the feed, or quantity of corn permitted to pass under the operation of the grinders in a given time. In a subsequent number we purpose inserting a description of one of the same kind of machines, which is in use at the workhouse of All Saints, near Hertford, where it is worked by any number of men, from two to ten, (by a suitable alteration of the feed,) and is capable of properly grinding and dressing as much corn in a given time as other mills will grind only; the estimated power required to work it efficiently being that of one horse, whether worked by that animal, or by wind, water, or steam.

“We shall now proceed to describe the hand-mill, with reference to the

engraving before adverted to. *a* is an axis, mounted in plummer-blocks *b b*, and turned by a winch *c*, assisted, if required, by a handle *d*, fixed to one of the arms of the fly-wheel *e e*. The axis *a* also carries a bevelled wheel *f*, which drives a pinion *g*, fixed upon a vertical spindle *h*, that revolves in the centre of a metallic hopper *i*, and carries at its lower extremity the upper grinder; and



to the periphery of the latter is attached a series of brushes, that revolve together with it inside the circular case *j*, cast in one piece with the hopper *i*. The lower grinder is fixed in the centre of the flat top *k* of the pedestal; and around the lower grinder, in the same plane as its superior surface, is an annulus of fine wire-gauze; over the area of which the brushes sweep in their revolution, continually scattering every particle of the meal, as the same is constantly projected in minute quantities all around the peripheries of the grinders, on to the wire-work; causing the flour to fall through the meshes into the drawer *m m*, below;

while the bran and pollard, which cannot pass the wire-gauze, are continually being freed from their adhering flour by the action of the brushes, until they are driven through an aperture at the outer circumference of the wire-gauze, on to an inclined screen of coarse wire-work, where the offal separates itself, in the mere act of falling, into pollard and bran, both of which deposit themselves into separate compartments made in the drawer *n*. At *l* is a screw for regulating the admission of the corn; and at *o* is a lever over an engraved plate, which directs the operator which way to move it, according as he may desire to regulate the grinding, whether coarser or finer than it was previously set. These adjustments are obvious to the sight, and unerring in their action.

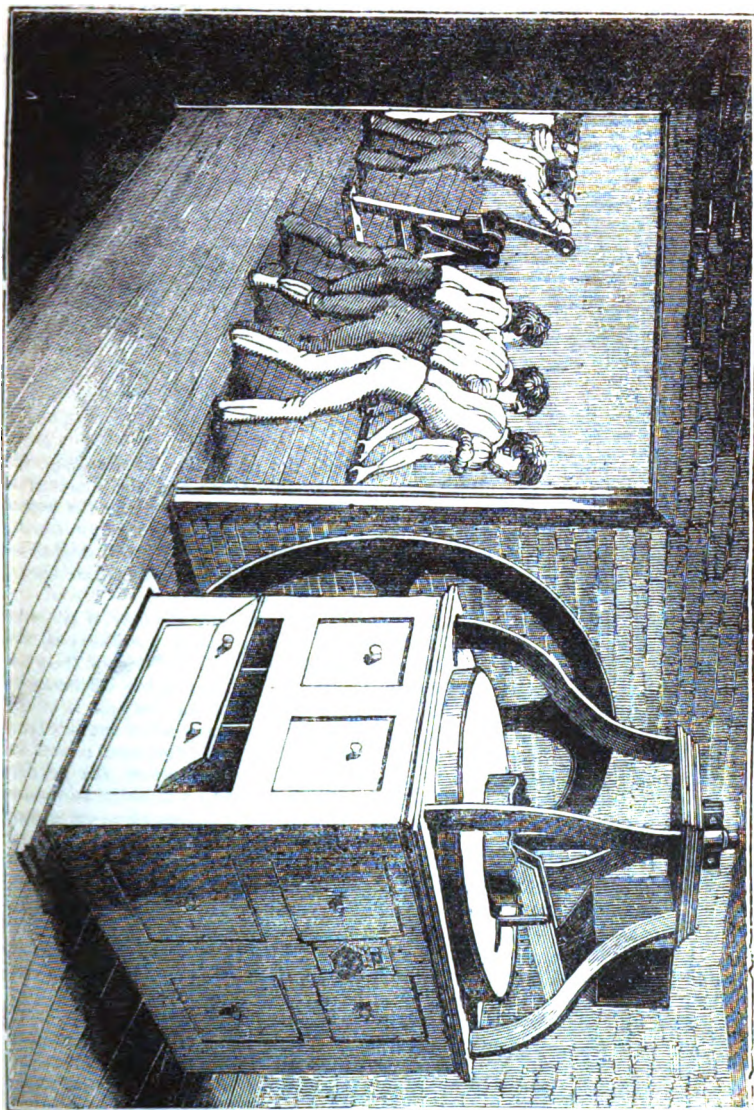
"Amongst the advantages which this machine presents to the economist may be stated its convenience, portability, and perfect cleanliness, and there being no dust or waste of any kind. It is particularly adapted for the use of domestic families, who are desirous, not merely to make their own bread, but to be sure that the flour which they use is a genuine product of good wheat. As respects its utility to emigrants and distant settlers, we have reason to believe that its merits have already been very satisfactorily tested; the durability of the grinding surfaces being such as to render a renewal of them apparently unnecessary for a series of years. A mill of this kind may be seen at No. 20, Pater-noster-row."

Since the foregoing account appeared in the *Mechanic's Magazine*, several valuable improvements have been made in the machine. The wire gauze through which the metal is sifted, is now rendered capable of being easily withdrawn, so as to convert the machine into a simple mill, the whole or gross produce being at once deposited in the large drawer: its utility is thus much extended, as there are many substances that do not require sifting.

Owing to a mistake made by the draftsman, the pedestal of the mill in the foregoing cut is represented as disproportionally small. With reference to the larger class of machines constructed on the same principle, and alluded to in the foregoing extract, as being in operation at Hertford, we may be permitted to observe, that one of the prominent disadvantages of the working of mills and dressing-machines of the ordinary construction in a workhouse, is the necessity of employing a *paid* servant to superintend and direct their operations: to which may be added the frequent stoppages in the work, for taking up the stones to recut, or dress their surfaces anew, a process which requires great millering skill and practical experience to execute in an efficient manner; and however ably it may be performed, it unavoidably entails a great waste of time, much labour, and wear and tear of tools and machinery. But the extraordinary simplicity of this patent machine, (which is now being introduced into several of the workhouses conducted under the new system of poor laws,) renders the management of it so easy and obvious, that the master of the workhouse can, without any difficulty or inconvenience, superintend its operation, or depute any unskilled labourer, in whom he can confide, to occasionally look to its performance; as the machine requires no active duty, but continues to perform, uniformly for months together, all its operations of grinding, dressing, and separating its various products of flour, pollard, bran, &c. without any interference, but that of keeping it clean and properly oiled.

The mechanical arrangements of this new machine equally adapt it to the production of every quality of flour and meal that may be required; to grind and dress finer or coarser, at the pleasure of the operator; to grind, break, or crush only, without dressing; to dress only, without grinding; and may be equally well worked by any number of men or boys, from only one up to twenty, the quality of the products being the same, and the difference only in the quantity. A machine of this kind has now been in active operation for several months, at All Saints' Workhouse, of the Hertford Union, the guardians of which, as well as the master, Mr. Booth, have testified to the facts just mentioned. The framing of this machine is made partly of oak, but all those since constructed are entirely of metal, and combine other improvements, which add to their practical convenience; one of which may be seen in operation at

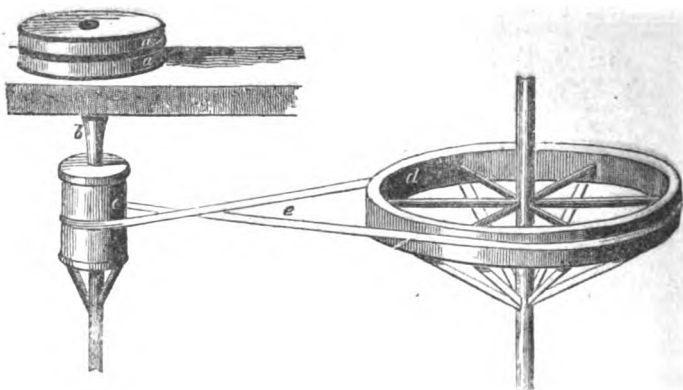
Dr. Allen's excellent establishment for the cure of mental diseases, at High Beech, near Woodford, Essex.



The following description of an economical horse-mill, for grinding corn, is extracted from a communication in the *Franklin Journal* for July, 1826, addressed to the farmers and planters of the United States:—*a a* are the mill-stones; *b* the spindle, which supports the upper stone; *c* a drum upon the spindle made long to prevent the band slipping off; *d* a large gin with its shaft, and arms (the lever to which the horse is yoked is not shown); *e* the bolt of tanned leather, five or six inches broad, with a buckle to give it the necessary



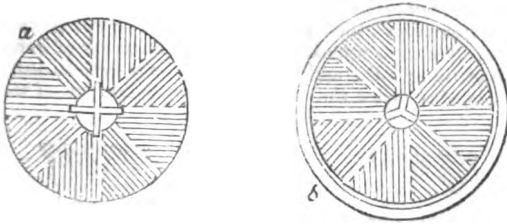
tightness. It has not been thought requisite to show the hopper and other necessary appendages, as with these every country mechanic is well acquainted. The larger the diameter of the circle in which the horse travels the better, but



it should on no account be less than 18 feet; the proportion of the large and small drums must be regulated by the size of the stones and the diameter of the horse-track; and it would in most cases be found best to place the hopper and stones under cover, as in the corner of a barn, and the large gin outside, by which means a large horse-track might be formed, and the mill might likewise be driven in wet weather. In the mill previously noticed at Dr. Allen's, the usual necessity of a horse-wheel is entirely obviated.

The largest description of corn-mills in the present day are driven either by water, wind, or steam. Watermills were in use amongst the Romans, who established several of them in this island; the mill-course of one of these was discovered some years back near Manchester. Windmills, we believe, were likewise known to them; but the application of steam to this purpose is of very recent date, the first steam-mills established in this or any other country being those erected by Bolton and Watt, near Blackfriars' Bridge, and named the *Albion Mills*. Whatever be the nature of the driving power, the grinding apparatus is nearly alike in all their mills; and as both windmills and watermills are employed for various purposes besides that of grinding corn, we propose, under the head WATERMILL and WINDMILL, to notice the methods of applying the power derived from these sources, and shall, in this place, give a description of a mill of modern construction, as driven by steam: we should, however, observe, that under the head BARKER'S MILL, the reader will find a water corn-mill of a simple description.

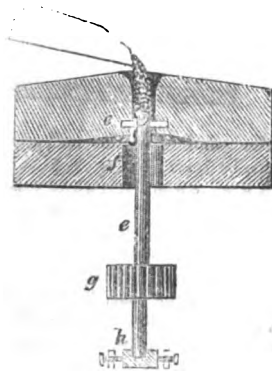
We shall preface our description of the mill by a short account of the form and the manner of facing the millstones. In order to cut or grind the corn, both the upper and under millstones have channels or furrows cut in them, proceeding obliquely from the centre to the circumference, as shown in the figure on p. 155. The furrows are cut perpendicularly on one side, and obliquely on the other, into the stone, which gives to each furrow an inclined plane, up which the corn is forced by the revolution of the upper stone, which crushes it and bruises it so as to make it grind easier when it falls upon the spaces between the furrows. These are cut the same way in both stones, where they lie on their backs (as above represented), which makes them run crossways to each other, when the upper stone *a* is inverted, and its furrowed side applied to the furrowed side of *b*. When the furrows become blunt and shallow by wearing, the running-stone must be taken up, and both stones new dressed with a chisel; and every time that the stone is taken up, a small portion of tallow should be applied to the bush of the spindle.



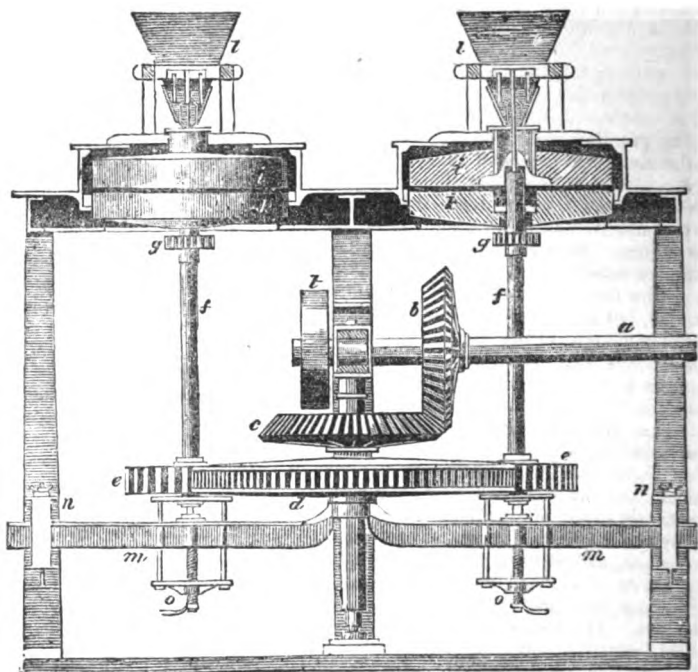
The grinding surface of the under millstone is a little convex from the edge to the centre, as exhibited in the annexed section at *b*, and that of the upper stone a little more concave; so that they are furthest from one another in the middle, and come gradually nearer towards the edges. By this means, the corn at its first entrance between the stones is only bruised; but as it goes further on towards the circumference, or edge, it is cut smaller and smaller, but at last finely ground just before it comes out from between them.

But although, in the diagram above given, the concavity in the upper stone corresponds with that described by several authors, we believe that the upper stone is not usually cut away to a greater extent beyond the mill-eye than that shown in the figure in the margin p. 151, where the grain is shown entering the mill-eye, and passing through the apertures of the rind *c*, it enters the cavity underneath; here it gradually gets broken, bruised or coarsely ground, and from thence the finest portion enters between the *parallel* surface of the millstones, and by degrees passes from between them at their peripheries, being constantly urged outwards by the pressure of the grain in the middle, as well as by the centrifugal force. The rind *c* is an iron cross let into the upper millstone, and is fixed to the spindle *e*; and the cavity *f* is filled completely by a bush (generally of wood), in which the spindle revolves. The trundle *g*, (driven by a cog-wheel, which is actuated by the first mover,) gives motion to the spindle and the upper stone. The surface of the upper stone is brought to a perfectly parallel position with respect to the other, by means of four equidistant regulating screws, acting upon a brass box *h*, in which the lower extremity of the spindle works; so that the slightest movement of the box, effected by the screws, makes a correspondent alteration in the position of the upper stone, enabling it to be adjusted to the lower one with the nicest precision and the greatest facility.

We shall now proceed to describe the engraving on p. 156, which represents a very compact arrangement of a mill, having four pair of stones driven by a steam-engine. The stones are placed at equal distances from the centre of a square platform, resting upon cast-iron columns, and the driving is arranged beneath the platform, and supported by a framing of iron fixed to the columns. *s* is the horizontal shaft driven by the steam-engine, on which is fixed the bevil-wheel *b*, working into another bevil-wheel *c*, of equal diameter, fixed upon the same vertical shaft which carries the large spur-wheel *d*; this spur-wheel works into four pinions *ee*, fixed upon the spindles *ff* of the upper millstones, only two of which can be seen; *gg* are indented pinions, for the purpose of agitating



the sieves placed over the hoppers, for preventing stones and other extraneous substances entering the hopper; *ii* are the upper millstones; *kk* the lower millstones; *ll* the hoppers, from which the corn descends into a swinging kind of hopper, called the shoe, which is continually shaken by a short bar of iron screwed into the upper end of the spindle, and having four prongs, which, striking the shoe from side to side, distributes the corn equally over the eye of the mill stone.

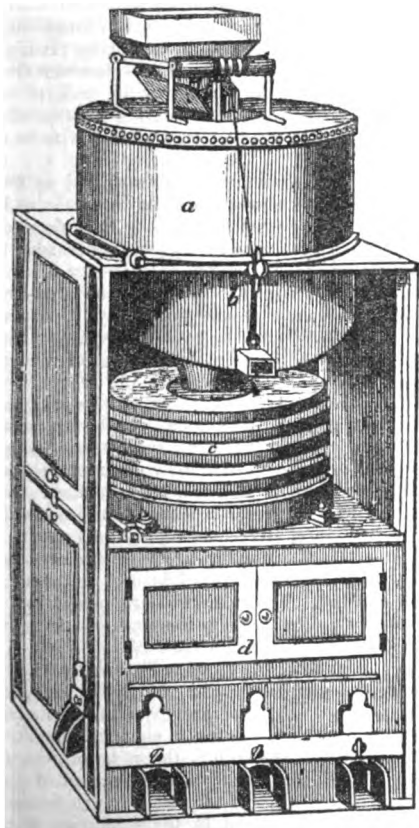


The spindles of the mill-stone are supported on the iron levers *m m*, which can be raised or lowered to adjust the stones, by means of regulating screws at *n n*; *o o* are screws to raise the pinions *e e*, and cast them out of gear. The under, or bed stones, are partly sunk into circular holes in the platform, and firmly wedged therein, and a circular case incloses each pair of stones, leaving a space of about two inches all round them; and the corn, reduced to the state of meal, is thrown, by the centrifugal force of the stones, out in all directions into the case, from whence it is conveyed to the bolting machine, which is driven by a band from the drum-wheel *t*. The bolting machine is not shown, as the reader will find a description of an improved one under the word **BOLTING-MACHINE**.

In grinding wheat, it is usually the endeavour of millers to separate all the flour from the husk without pressing it so hard as to *kill it*, and without deteriorating its colour by making minute *greys*. This they have not been enabled to effect in a desirable manner with the mills constructed on the usual plan, nor by any form of construction that has hitherto appeared. The reason is obvious;—if the stones be brought so close together as is necessary to remove the firmly adhering portions of the flour from the husk, the whole of it will be, in a great degree, *killed* and discoloured by the violent rubbing necessary to clean the bran; on the other hand, if the stones are kept further apart, so as to *grind high*, much of the flour will be left in the offals and bran.

With a view of meeting these difficulties, some millers have ground their wheat at two distinct operations; they have, in the first place, set their stones wider apart, or *grind high*; and then, after collecting the meal, and separating the fine flour from it, have passed the remainder a second time through the stones, setting them closer than before, or *grinding low*. Thus have they removed the whole of the flour from the husk, and preserved the good quality of a part of it; but the waste, and loss of time and power in conveying the meal from one place to another, occasioned by these several operations, together with the difficulty of separating the flour from it in the unfinished state by the ordinary dressing machine, have been found to neutralize the advantages otherwise resulting from this mode of proceeding.

In consequence of the great size and weight of the stones usually employed, the erections and fittings up of the ordinary mill are necessarily very heavy and expensive; and, owing to the several processes of grinding, cooling, dressing, and clearing up, being distinctly conducted in situations remote from each other, a considerable waste of flour, together with much unnecessary manual labour, and waste of mechanical power, are incurred. These disadvantages, which are inseparable from the old system, are completely obviated by the patent progressive corn-mill, manufactured by Messrs. Cotterill and Hill, of Walsal, in Staffordshire, from the following causes:—Instead of employing only



a single pair of stones of great weight and diameter (by which a large portion of the flour that is formed near the eye of the stone has to pass, with the bran,

over a greater extent of surface than is necessary, thus injuring it by superfluous raising, besides misemploying the motive power for the purpose), the progressive mill is provided with two pair of stones, of smaller diameter; and underneath the first pair (shown in the figure, as in the case at *a*) is suspended and agitated a circular sieve *b*, which receives the product as it falls freely from the stones, and separating that portion of the flour which is sufficiently reduced, or softened, it delivers the unfinished portion into the eye of the second pair of stones underneath, shown at *c c*, with their case removed, as well as one of the external shafts which inclose the whole machine when at work. This second pair are set closer together than the first, to complete the softening of the remainder of the meal, which in consequence of the bulk of the flour being separated from it, will be much more easily operated upon, and, at the same time, effect a saving of power. Underneath this pair of stones is placed at *d*, inclosed in its case, a dressing-machine, with brushes, which receives the meal from the stones as it is ground, and separates the remaining flour, as well as the different qualities of offals. When several progressive mills are employed, the meal resulting from the second pair of stones in each mill may be advantageously conducted into one dressing-machine, common to them all. In consequence of this division of the grinding operation into two stages, and the small size of the stones employed, the meal is not heated. This, together with the important circumstances of the bulk of the flour being separated from it, in the first instance, without brushing, renders the remainder fit for dressing up as fast as it is ground. By this arrangement, therefore, it will be readily perceived, that the original colour and strength of the flour is preserved; that all the flour is separated from the bran without any injury to the bulk of it; and that the whole process of grinding, dressing, and clearing up the offals, is one continuous operation, performed in one compact machine, without waste, and with little manual labour.

The progressive mill is made principally of iron, and so arranged and put together, that, while the nicest accuracy in its adjustments, and certainty in its operations, are insured, the stones may be taken up to be dressed, and put down again with the utmost facility and ease. Its parts are readily taken to pieces, so as to make it easy of conveyance; and in consequence of all of them coming together with metallic faces, it can be properly re-connected by the commonest workman; and from its compactness and portability, it is peculiarly adapted for exportation, as the entire mill can be packed in a strong case, and the total weight of it is very little more than the stones alone of a common mill doing the same work.

**MINE AND MINING.** Mine is a term applied to works carried on underground, for obtaining minerals generally, but chiefly for metallic ores. The internal parts of the earth, as far as they have been investigated, consist of various strata or beds of substances, extremely different in their appearances, specific gravities, and chemical qualities, from one another. Neither are these strata similar to one another in different countries; and in one district, the strata varies considerably in its nature, at very short distances apart. Rocks of most kinds are traversed in every direction by cracks or fissures, having, in many instances, the appearance of those formed in clay and mud while gradually becoming dry in hot weather. These fissures are in general filled with substances formed of materials differing from the rocks in which they are situated. When they contain minerals partly composed of any kind of metal, they are called metallic veins, lodes, or courses. Metallic veins are only found in what are called the primitive rocks, as granite and slate; and, in general, their course is from east to west. A vein rarely consists of metal in a pure and malleable state, but is almost always found in chemical combination with other substances; in this state it is called an ore, the metal of which is separated by the process called *smelting*, which is, in fact, a melting-out of the metal from its combinations, usually effected by the addition of such foreign substances as will, by their chemical affinities, assist in the separation of the metal. The thickness, extent, and direction of a vein of metal, depends on many circumstances; in general, its course downwards is in a slanting direction, more or

is inclined; if it continues in a straight line, and of a uniform thickness, it is called a *rake*; if it occasionally swells out in places, and again contracts, it is termed a *pipe-vein*, and the wider parts of the vein are called floors; sometimes the vein divides itself into branches, and then it is said to *take horse*; in other cases a cross grain will interfere with it, and heave or lift it, as it were, from 10 to 20 feet out of its course. At times it will be reduced to a mere thread, and at last become completely obliterated, appearing again at a distance. In many of these cases the difficulty of tracing these precious deposits through their rocky labyrinths must be evident. In all probability, however, the metals were at first procured from detached fragments of the ores, such as had been separated from the upper parts of the veins in which they were originally deposited; and in this manner is gold yet procured, by washing the sands of certain rivers. The pursuit of these scattered pieces of ore would naturally conduct the persons thus employed to the beds from which they had been detached, and in turning over the soil to procure the loose fragments, the backs of the veins would be laid open and discovered.

The tin of Cornwall was the first metal sought after in Britain of which we have an historical account; but the traces of the most ancient tin-works exhibit no symptoms of their having been pursued but in situations where the soil with which it was mixed could be easily removed, or where the ore could be laid bare by conducting over it streams of water to carry off the lighter parts of the soil. Lead is often found near the surface of the earth, and as the ores generally exhibit a metallic appearance, that metal was probably an early object of pursuit; but it was not until machines were invented to pump away the waters, and until gunpowder had furnished the means of splitting the hardest rocks, that man was enabled to penetrate strata of every description that opposed his progress. These inventions, therefore, form most important epochs in the history of mining. The hammer and wedges were probably the first instruments employed for splitting rocks, and the pick followed, which is used both as a hammer and a wedge. Previously to the use of iron, wedges of dry wood were made use of by driving them into clefts of the rock, and then wetting them, so as to cause them to swell and force the parts asunder. The means employed for raising up the minerals to the surface were at first extremely rude. The windlass and bucket may be reckoned an improvement which took place in a later stage of mining. This simple mechanism had its origin in Germany; and before it was introduced into this country, the mode adopted here was by making successive stages, upon each of which men were placed, who raised the excavated matter from one to the other until it reached the top, in the same manner as is now commonly practised in digging out the foundations for houses, or for making deep drains. In South America the ores are for the most part carried up by the Indians; and where the situation admits of sloping roads, on the backs of mules. To Germany may also be traced the introduction of hydraulic machines for raising the water constantly collecting in the mines. Pumps were adapted to the shafts, and their constant action secured by giving motion to their pistons by wheels turned by descending streams of water. To England, however, belongs the merit of having greatly improved the pump-work and the water-engines to their present effective condition; and by the subsequent application of the steam engine to this purpose, the mining processes of our countrymen have so far surpassed those of other countries, as to render their adoption indispensable in most situations.

Although copper is now the greatest metallic product of the county of Cornwall, it is comparatively, to the other metals, of modern discovery, not having been worked longer than a century. The reason assigned for its having so long remained concealed, is the assumed fact, that copper generally occurs at a much greater depth than tin; and that, consequently, the ancients, for want of proper machinery to drain off the water, were compelled to relinquish the metallic vein before they reached the copper. It is stated by Pryce in his *Mineralogia Cornubiensis*, as a general rule, that tin seldom continued rich and worth working lower than 50 fathoms; but of late years the richest tin mines of Cornwall have been much deeper. Trevenen mine was 150; Hewas

Downs, 140; Poldice, 120; and Herel Vor is now upwards of 130 fathoms in depth. Upon the first discovery of copper ore, the miner, to whom its nature was entirely unknown, gave it the name of *poder*; and it will be hardly credited in these times, when it is stated that he regarded it not only as useless, but upon its appearance was actually induced to abandon the mine: the common expression upon such an occasion was, "that the ore came in and spoilt the tin." About the year 1735, Mr. Coster, a mineralogist of Bristol, observed this said *poder* among the heaps of rubbish; and seeing that the miners were wholly unacquainted with its value, he formed the design of converting it to his own advantage, and accordingly entered into a contract to purchase as much of it as could be supplied. The scheme succeeded, and Coster long continued to profit by Cornish ignorance. Besides tin and copper, some of the Cornish mines yield cobalt, lead, and silver. The ores are in veins or lodes, the most important of which run in an east and west direction: during their course they vary considerable in width from that of a barley-corn to thirty-six feet; but the average may be stated at from one to four feet. The number of mines usually at work in Cornwall, is estimated at about 130.

The mines of Cornwall and Devon are generally worked by a company of proprietors, called adventurers, who agree with the owner of the land, or the lord of the soil, as he is usually denominated, to work the mine for a certain number of years, paying him, by way of rent, a proportion of the ores raised, or an equivalent in money. The grant thus made to the adventurers is called a *set*, and the lord's rent, if paid in ore, is said to be the lord's *dish*; if paid in money, his *dues*. The adventurers divide their undertaking into shares of different magnitude, the smallest usually held being one sixty-fourth part. Any part of the concern held by one person is called a *dole*, and its value is known by its being denominated an eighth-dole, a sixteenth-dole, &c. The bounds or limits of a mine are marked on the surface by masses of stone pitched at equal distances; but the property of the soil above is entirely distinct from that part of the mine beneath it; the miner, however, has the privilege of making openings or shafts at stated intervals, for the purpose of raising the ore, and admitting air to the works. In opening a new mine, considerable knowledge of the country, and of the most likely situation of the metallic veins, is of course necessary to avoid the chance of useless labour. The spot for commencing operations having been selected, a perpendicular pit or *shaft* is sunk, and at the depth of about sixty feet a horizontal gallery or *level* is cut in the lode by two sets of miners, working in opposite directions, the ore and materials being raised in the first instance by a common windlass. As soon as the two sets of miners have cut or *driven* the level about 100 yards, they find it impossible to proceed for want of air; this being anticipated, two other sets of men have been sinking from the surface two other perpendicular shafts to meet them; from these the ores and materials may also be raised. By thus sinking perpendicular shafts, a hundred yards from each other, the first level or gallery may be carried to any extent. While this horizontal work is going on, the original, or as it is termed, the *engine shaft*, is sunk deeper; and at a second depth of 60 feet, a second horizontal gallery or level is driven in the same direction as the first, and the perpendicular shafts are all successively sunk down to meet it; in this manner galleries continue to be formed at different depths, as long as the state of the lode renders the labour profitable. The engine shaft in the mean time is always continued to a greater depth than the lowest *level*, for the purpose of keeping the working-shafts free from water. The object of these perpendicular shafts is not so much to get at the ores, which are directly procured from them, as to put the lode into a state capable of being worked by a number of men; in short, to make what is termed a *mine*. It is evident that the shafts and galleries divide the rock into solid right-angled masses, each 300 feet in length, and 60 in depth. These masses are again subdivided by small perpendicular shafts into three parts; and by this arrangement the rock is finally divided into masses called *itches*, each 60 feet in height, and about 100 feet in length.

In the Cornish mines, the sinking the shafts, and driving the levels, is paid for by what is termed *tut-work*, or task-work, that is, so much per fathom; in

addition to this the miners receive a small per centage on the ores, in order to induce them to keep the valuable portions as separate as possible from the *deads*, or rocky parts of the mass.

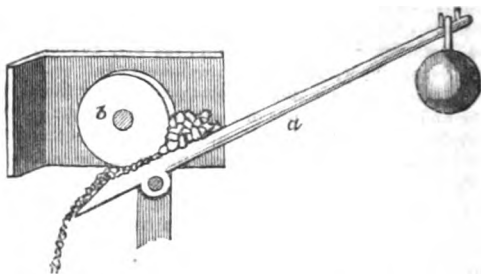
In addition to these horizontal and perpendicular shafts, another description of gallery is formed, called an *adit*; the use of this shaft is to drain the water from the lower parts of the mine. Where the mine is formed in an exposed rock, as in the Botallick mine, in Cornwall, the adit can carry off the water without the aid of machinery, as long as the lowest shaft is above the level of the sea; but when the shafts are sunk below that level, or that of the adit itself, recourse must be had to the assistance of steam-engines to pump up the drainage to a sufficient height. The great Cornish adit, which commences in a valley near Carnon, receives branches from fifty different mines in the parish of Guennap, forming altogether an excavation nearly thirty miles in length. The longest continued branch, is from Cardrew mine, five and a half miles in length; this stupendous mine empties itself into Falmouth harbour.

The lode, when divided as above described, is open to the inspection of all the neighbouring miners in the country, and each mass or compartment is let by public competition for two months, to two or four miners, who may work it as they choose. These men undertake to break the ores, and raise them to the surface, or as it is termed *to grass*, and pay for the whole process of dressing the ores, that is, preparing them for market. The men by whom the mines are worked in this manner are called *tributers*, and their share of the value of the ore, which varies according to its richness in metal, is named *tribute*. This tribute is paid over to them every week, the mineral being disposed of at a *ticketing*, or weekly sale. In addition to the working miners, a set of men, whose experience entitle them to the office, are engaged at a stated salary, to act as overlookers, and direct the labours of the rest; those whose business lies in the mines, are called *under-ground captains*, and those employed above ground *grass captains*. The weekly produce of the mine being made up by the tributers into heaps of about one hundred tons each, samples, or little bags from each heap, are sent to the agents for the different copper companies. The agents take these to the Cornish assayers, a set of men, who (strange to relate,) are destitute of the most distant notion of the theories of chemistry or metallurgy, but who nevertheless can practically determine, with great accuracy, the value of each sample of ore. As soon as the agents have been informed of the assay, they determine how much a ton they will offer for each heap of ore at the weekly ticketing. At this meeting, all the mine-agents, as well as the agents for the several copper companies, attend, and it is singular to see the whole of the ores, amounting to several thousand tons, sold without the utterance of a single word. The agents for the copper companies, seated at a long table, hand up individually to the chairman, a ticket or tender, stating what sum per ton they offer for each heap. As soon as every man has delivered his ticket, they are all ordered to be printed together, in a tabular form. The largest sum offered for each heap, is distinguished by a line drawn under it in the table, and the agent who has made this offer is the purchaser.

In order to prepare copper ores for market, the first process is to throw aside the rubbish, with which they are unavoidably mixed; this task is performed by children. The largest fragments of ore are then *cobbed*, or broken into small pieces, by women, and after being again picked, they are given to what the Cornish miners term *maidens*, that is, young girls. These maidens *buck* the ores, that is, with a bucking-iron, or flat hammer, they break them into pieces not exceeding half an inch in size. The richer parts of the ore, which are more easily broken, are now crushed smaller in a kind of mill, the principle of the construction of which is shown in the diagram on p. 162; where *a* represents a weighted lever, by the depression of which the ore between it and the roller *b* becomes crushed; and on the raising of the lever, the crushed ore falls away, and a fresh portion of ore is thrown into a position to receive the pressure upon the succeeding depression of the lever. The coarser portions, which are the hardest, are bruised in a *stamping mill*, in which heavy weights or hammers are fixed by cams on a revolving shaft, and allowed to fall upon the ore, a stream



of water constantly passing through the mass, and washing away the portion which is sufficiently reduced to pass through the holes made in an iron plate, which forms one side of the box in which the stampers work.

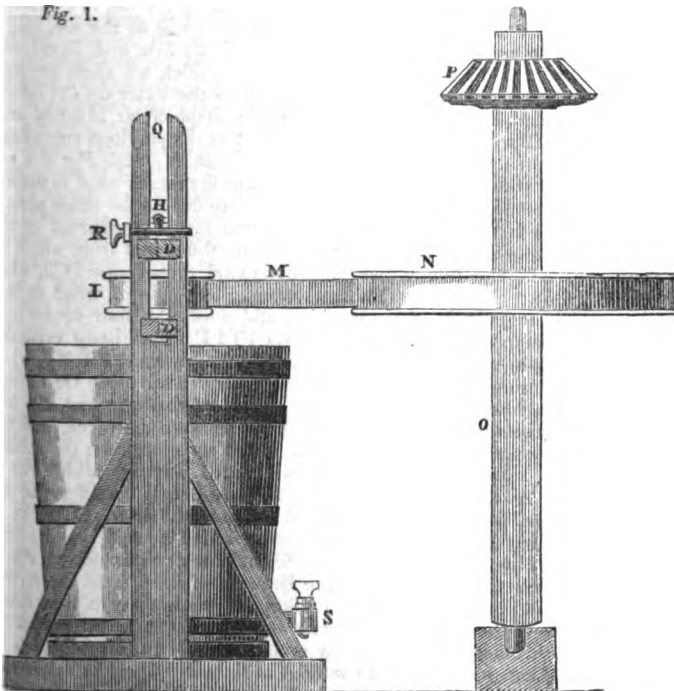


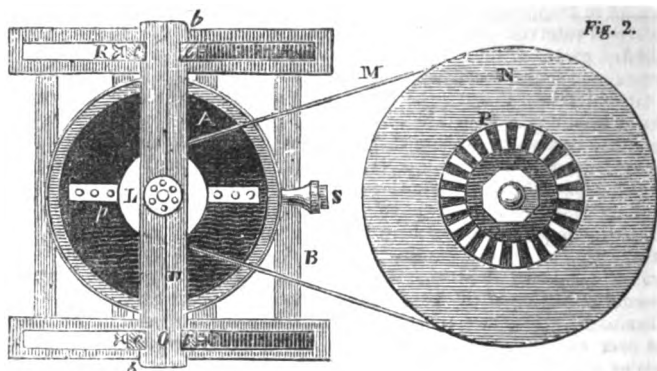
The next operation is that of *jigging*; this used to be performed entirely by boys, and consists in shaking a quantity of bruised ore in a kind of sieve, with an iron bottom to it, while under water. This occasions the heavier parts, which consist almost entirely of metal, to sink to the bottom; while the earthy matter is washed away, and the small fragments of stone, being lighter than the metal, and containing little or no ore, are left on the surface in the sieve; these are carefully skimmed off with the hand, and the remainder is piled up in heaps for sale. This process has been recently considerably improved by Mr. Thomas Petherick, a mine-agent, of Penpellick, who took out a patent in 1830, "for machinery for separating copper, lead, and other ores from earths and other substances with which they are and may be mixed, and is more particularly intended to supersede the operation now practised for that purpose, commonly called jigging." This machinery is thus composed; namely, a large vat or tub, with a fixed cover, in which cover are apertures and receptacles adapted to the form and size of a number of sieves, such as are used in the operation of separating copper, lead, and other ores, from the substances with which they are usually mixed. The vat is filled with water, and the sieves with the minerals in them are placed in their receptacles, so as to be immersed in the water contained in the vat; the interior capacity of which communicates with the interior capacity of a hollow cylinder; into this a plunger or piston is fitted, which is moved alternately up and down within it, so as alternately to displace water therefrom, and force the same into the vat, and then withdraw water from the vat into the hollow cylinder; thus causing a sudden flux and reflux of the water through the sieves, which is continued until the required degree of separation of the earths from the ores is effected.

In the specification of a second patent, granted in 1832, to Mr. Petherick, in conjunction with Mr. Kingston, of Islington, in Devonshire, for improvements in the patent machinery just described, it is directed that the aforesaid cylinder is to be provided with a bottom plate and foot valves, opening outwards to allow the escape of the water into the vat, but not to permit its return; and the piston is furnished with valves opening downwards to allow the water to pass through it in that direction, so that the motion of the piston shall cause the water to pass through the cylinder the same as in a common lifting water-pump. By this improvement, the water instead of being made to pass up and down through the sieves, containing the minerals, as in the previous plan, is forced through the sieves by a series of impulses varying in extent and intensity with the proportion of the area of the piston to the areas of the sieves, and the extent and rapidity of the motion communicated to the piston. The first mover of this machinery may be steam, or water, or horse, or man power, as circumstances may demand. It is proposed by the patentees as one modification of their plans, to carry a shaft from a first mover over a series of separating plates placed in a row, and made to actuate each piston, by means of a piston

rod and crank connected with the main shaft. It is also proposed by the patentees in the specification of this second invention, to admit the water from an elevated reservoir into the sieve vat, instead of forcing it in by a pump, as in the first part. If there be a sufficient supply of running water, the elevated reservoir is to be kept constantly filled therefrom, and it is to be admitted into the vat and forced through the sieves, by means of a stop-cock or valve, in a series of impulses, actuated by an hydraulic pressure proportionate to the altitude of the reservoir. Where there is not a running stream for the supply of the elevated reservoir, the water is to be pumped up again for that purpose, after it has passed through the sieves. The stop-cocks or valves for the admission of the water from the reservoir to the vat, are to be opened and closed to produce the impulses, either by a boy operating with a lever, or by being connected with one of the pumps or water wheels, when such are used. The patented machinery of Messrs. Petherick and Kingston, is, we are informed, in successful operation at the Lancscot and other Cornish mines.

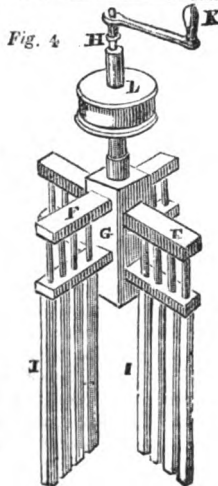
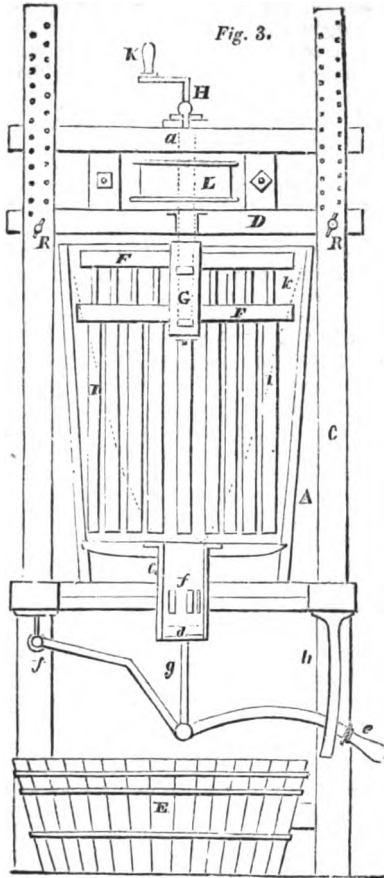
Diamonds, gems, and the precious metals being scattered in minute quantities over extensive surfaces of ground, chiefly of alluvial soil, the process of obtaining and separating them from the matrices and earths with which they are naturally combined, is extremely tedious when conducted by the ordinary processes of washing, stamping, and picking; any improvements, therefore, in the apparatus, by which the labour can be considerably abridged, is of essential importance to those who are interested in such pursuits. The improvements which have been patented by Mr. Harsleben, appear to us to be deserving of that character; and having been informed that they have been very successfully introduced in some of the gold mining districts of America, we shall here annex





a detailed description of his apparatus, prefacing our account with the observation, that its application is not confined to the more precious metals, but may be advantageously employed in the separation of other solid substances of dissimilar specific gravities. If the matrices in which metals are found are of a hard and stony nature, they must, in the first instance, be reduced by hammers, or by the operation of an ordinary stamping-mill, to powder or dust; for the smaller the particles are, the more effectually will they be separated by the subsequent process. The materials so prepared are put into a deep conical or cylindrical tub, with a quantity of water sufficient to permit the whole of the ore, soil, or other powdered materials, to float about in a perfectly free and liquid state whenever the water is stirred round by the agitators, which we shall presently describe; and with a force and velocity so as to drive the water up the sides of the tub in such manner, that a hollow space, in the shape of an inverted cone, may be formed in the water within the tub. *Fig. 1* of the previous engravings, is a side view of the apparatus; *Fig. 2* a plan of the same; and *Fig. 3* a section of the tub, to show the form of the agitator, and the means used to suspend and move it; the same letters of reference are used to denote the same parts in all the figures. A is the tub, quite smooth in the inside, supported upon a platform B, forming a part of the frame of the machine, and from which the two standards, C C, rise that support the horizontal cross-frame D D, which carries the agitator F G H I. This agitator may be made of wood or iron, according to the magnitude of the machine, and consists of four double arms F F F F, which support and carry the stirrers I I I I, which hang vertically. These stirrers may be screwed or morticed into the double arms F F F F, which are in like manner screwed or morticed into the strong central block G; through the centre of this block (which is also the centre of the agitator), the iron spindle H passes, being fixed by a nut and screw beneath the block, and terminating at its upper end in the handle k, which serves to turn the agitator round; on which account the spindle has two turned bearings, which run in brass boxes *a a*. As the power and velocity of the winch K would not be sufficient in large machines, a rigger is hung at L, upon the iron spindle H, so that the agitator may be turned by a band passing round it; and round a large rigger moved by a horse-wheel (or any sufficient power) as shown in *Figs. 1* and *2*, where M is the band, and N the large rigger fixed upon the vertical shaft O, the bevel pinion of which at P takes into the teeth of a large horse-wheel, not shown in the drawings because it does not constitute any part of the invention. By this mode of working any required number of machines can be placed round the horse-wheel, and be worked at the same time. The external bars of the stirrers I I come very nearly in contact with the sides, and their extremities very near to the flat bottom of the tub, so as to insure the

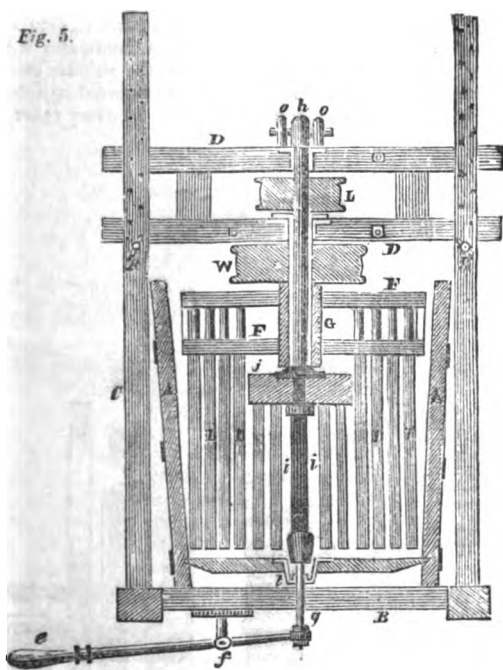
agitation of the whole quantity of material that may be mixed with the water, and prevent, as far as possible, the deposit of any part of the same, either on the bottom, or on the sides of the tub; and for the due adjustment of the ends of the stirrers to the bottom of the tub, the horizontal cross-frame DD is movable up and down in long morticed grooves, made for that purpose at Q Q, near the tops of the two standards C C, (as distinctly seen in Figs. 1, 2, and 6,) and is fixed at the required height by means of the iron screw-bolts R R, which pass into any of the series of holes made in the side of the standards, Figs. 3 and 5. A temporary elevation of the agitator may, at times, be necessary in first setting the machine to work, if the powdered ore or sand put into the water is of such a dense or heavy nature as to prevent the agitator from moving; while, by lifting it in the first instance, and then setting it in motion, and afterwards lowering it gently while in motion, it will gradually lay hold of the materials, and soon put them into a whirling motion. In the underneath Fig. 4, a perspective figure is given of the agitator, detached from the other parts of the machine; and for the purpose of so detaching it, the cross-frame DD, together with its brass boxes, are made to take asunder longitudinally, as seen in Figs. 1 and 2, but are bolted together whilst the machine is in use. S is a cock, or spigot and faucet for drawing off the water from the tub whenever it may be necessary; in addition to this, the centre of the bottom of the tub is furnished with a peculiar valve, the use and construction of which forms one of the leading features of this invention. This valve admits of different constructions, as will appear when its use has been described. One form of it is shown in section at Fig. 3, and another form at Fig. 5. In Fig. 3 cc is a brass or other metal cylinder, which must be bored in its inside like a pump barrel, in order that the piston d, which is packed with hemp, leather, or other fit



material, may move in a water-tight manner within it;  $ef$  is an iron lever turning on the fulcrum  $f$  for the purpose of moving the piston with which it is connected by the rod  $g$ ; and  $h$  is an iron loop or guide, which not only causes the lever  $ef$  to move up and down without external action, but also regulates and restrains its quantity of motion, which is necessary, because when the end  $e$  of the lever is drawn up to its highest possible elevation, the piston  $d$  should be at the top of the barrel  $cc$ , with its convex upper surface just projecting into the tub, as shown by the curved dotted line; and when the end  $e$  of the lever is at its greatest depression, the piston must be at the bottom of the said barrel, but must never move out of it; and when the said piston is in its lowest situation, as shown in the figure, its upper surface must be just below a row of large holes, which are formed round the said barrel as at  $ff$ ; consequently, while the piston is in its position, any fluid that may happen to be in the tub will flow out of it, through these holes, into a shallow tub  $E$ , placed underneath to receive it; but if the piston is raised rather more than its own thickness, it will cover all the said hole  $ff$ , and prevent the discharge of anything from the tub, although it will leave all the upper part of the barrel  $cc$  open, as a well or receptacle to receive anything that may fall into it; and this well, or receptacle, may, in a moment, be annihilated by pushing the piston upwards.

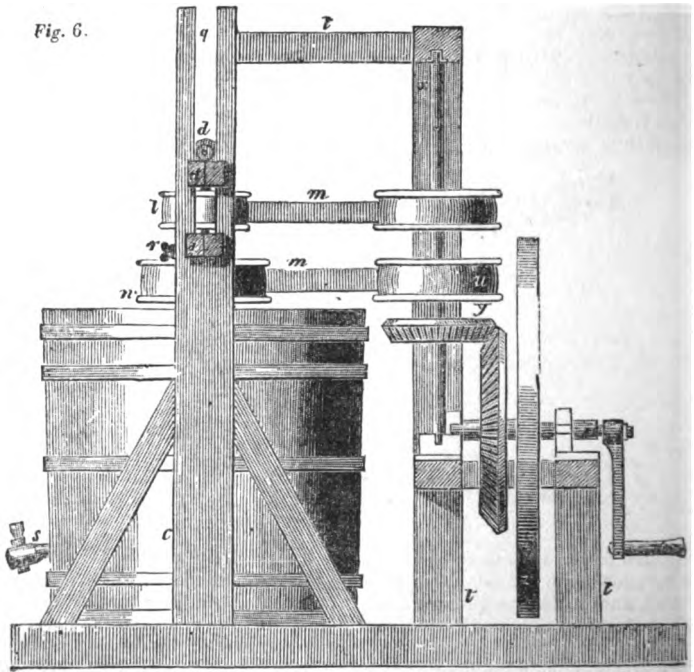
The other form of the valve, shown in *Fig. 5*, is similarly placed in the centre of the bottom of the tub, and for the same purpose, though rather more simple in its construction. It consists merely of a conical brass or other metal stopper, turned and ground, or packed so as to fit tightly into the hole of the metal plate  $tt$ , which is let into the bottom of the tub: this stopper is moved, as in the former valve, by the iron or metal lever  $ef$ , and attached to the plug or stopper by the iron rod  $g$ , so that the valve may be opened or shut at pleasure, by applying the hand to the end of the lever. It will be observed in all the above figures, and particularly in the perspective view of the agitator at *Fig. 4*, that there are no stirrers  $III$  in the centre of the agitator, but that a certain space, fully equal to the size of the central valve, is left free for them, not only for the purpose of permitting the valve to rise between the stirrers, but also to prevent the same degree of motion being given to the central part of the contents of the tub, that is given to the sides of it. Having so far described the general form and construction of the apparatus, we shall next proceed to describe the manner of using it, for the purpose of extracting the gold, silver, or other metals or materials, from the sand, earth, or other matrices with which they may happen to be mixed. For this purpose the tub  $AA$  must be about half filled with water, or, what is better, may communicate by a pipe, shoot, or trough, with water, which can at pleasure be permitted to run into the tub, or may be stopped; the cock  $S$  and central valve being of course closed at this time. The ore and matrice, or other material to be operated upon, reduced to a state of powder, must now be thrown in, in such quantity that it will not exceed in weight more than about half the weight of the water in the tub at any one time; but a greater or less quantity may be added, according to its density, which will be easily ascertained by practice. The agitator is then to be put into motion, beginning slowly at first, but quickening it until the whole quantity of water, and the materials that have been thrown into it, are put into rapid motion, and the whole of the ore, or other material, however heavy, has become completely incorporated with, and floats in, the water. It will soon be found, that the water, by its centrifugal force, will rise against the sides of the tub, and leave a hollow space in the middle of it, in the form of an inverted cone, as shown by the dotted lines  $kkkk$ , in the section of *Fig. 3*. This effect takes place to such an extent (if the height of the tub and the size of the agitator are properly proportioned to one another, and the motion is sufficiently rapid), that the central valve at the bottom of the tub can be distinctly seen from above, and may even be opened without danger of discharging much of the water; and if, after continuing this rapid motion for two or three minutes, it is gradually abated, and the agitator is brought to a state of rest, it will be found that all the gold or silver, or other metals, so mixed with the water, will be deposited in a heap in the centre of the tub, immediately over the central

valve, with very little admixture of the sand or earth that was previously mixed with it; and, consequently, if the piston *d* of the tub-valve in *Fig. 3* is lowered, so as to form the chamber or cavity, at the same time that the motion of the agitator is slackened, such heavy material will be deposited in the said chamber or cavity, and may be drawn off with a little of the sand, earth, and water accompanying it, into the receiving tube *E*, by lowering the said piston below the holes described at *fff* in the figure; but if the discharge should be followed by too much sand, earth, and water, it may instantly be stopped by raising the piston above the holes. Should the ore or other material not be sufficiently heavy to deposit itself in the centre of the tub, then the stopper valve, shown in *Fig. 5*, is to be used in preference, which is not to be opened until the fluid in the tub has been moved for a minute, and the central hollow cone is formed in the middle, when the stopper may be raised, and the speed of the agitator diminished, until the water begins to flow gently from the valve, when, in running, it will bring the ore, or other heavy materials with it, and must be



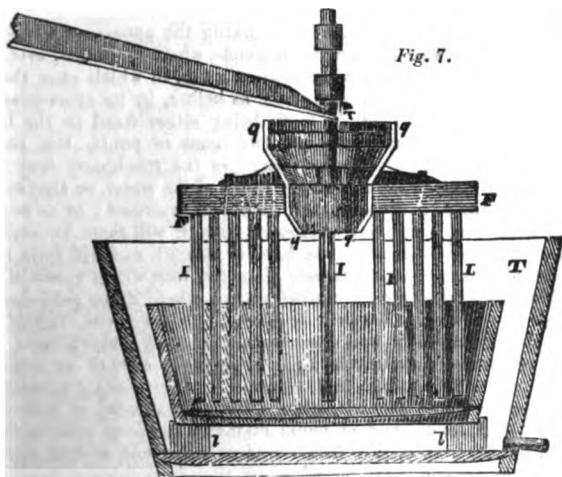
permitted to run so long as this is the case; the valve is then to be closed, and the agitator again put into rapid motion; after which the valve is to be again opened, and so in succession, until the whole of the ore, or other heavy material, is obtained, which will be known by its ceasing to run from the lower central valve, when the remaining refuse is to be drawn off by opening the valve and spigot *S*, having previously placed another tub, called the waste-tub, under the machine for the purpose of receiving it; and while so running off, the agitator must be kept in motion to stir it up and wash out the contents of the tub. When empty, the waste-tub, with its contents, must be removed, and the tub *AA* must be supplied with a fresh quantity of water and ore, or other heavy material, to resume the operation.

From the foregoing description of this machine in its most simple state, it will appear, that a much less proportionate quantity of motion takes place near the centre of the agitator, than near its outside, particularly when the machine is made on a large scale, on which account it is necessary, in large machines, to construct a double agitator, that is to say, one in which the central part turns or moves with greater velocity than the external part, as shown in section at Fig. 5, where I I I I F F show the agitator constructed as before, except that its arms and stirrers are more extended from the centre, so as to make room for the smaller central agitator *iii i* which may be constructed in the same way as before described, or may have its stirrers fixed into the circular block of wood or metal *jj*, and the iron axes, instead of being fixed into the central block G, now passes through it, and is fixed to the small or internal agitator. For this purpose, the central block G of the agitator should be lined with a brass box, or have proper bearings upon its ends, so that it may revolve freely upon the iron spindle H; it has also a bearing at *n*, in the lower part of the cross frame D D, to assist in supporting it; and on account of the greater weight that now hangs on the said iron spindle H, two friction wheels are fixed to its upper end, as at *o o*, which run upon the top of the brass bearing *p*, and materially diminish the friction. When the double agitator is used, two riggers will be necessary, as at L and W, and the one at W, which communicates with the large external agitator, is made double the diameter of the smaller one L, which is fixed upon the iron axle H, in order that the small internal agitator may move with double the velocity of the large external one. In every other respect, this



machine is the same as the one already described. Fig. 6, is an elevation of a machine, with a double agitator introduced, merely to show how such a machine, on a small scale, may be moved by hand. *l* and *w* are the two riggers of the internal and external agitators, as in the last figure, and motion is communi-

ated to them by the bands *ww*, which pass round the two riggers *v* and *u*, both of the same diameter, and both fixed upon the upright iron shaft *xx*, which also carries the bevelled wheel *y*, which is driven by the larger wheel *Y*, hung upon the main shaft, which also carries a heavy fly wheel *ss*, and the winch or handle by which the whole is turned. The timber framing *tt*, for carrying the said wheel and riggers, is too obvious to need description, and may be varied in form, to suit the convenience of the place in which the machinery is fixed; and when a horse is adopted for machinery of magnitude, it is almost needless to observe, that it must take into, and drive the wheel *y*, which for this purpose may be fixed higher on its shaft, when the wheel *y*, with its fly wheel, shaft, and handle, will be unnecessary. In the use of this machine, it is vain to expect to get the ore or other heavy material, separated from the sand, earth, or other material, with which it may be mixed, in a clean and perfect state, by one operation as hereinbefore described, because a considerable portion of sand and earth will inevitably run off with it in the water. The mode proposed by the patentee therefore is, to save all the first portions that run off from the central valve at the first washing, in a tub or other receptacle by themselves; and when a sufficient quantity is thus accumulated, it is to be again put into a machine, which may be smaller for this purpose, and it is to be treated precisely in the same manner as the crude materials in the first instance, when it will be further cleansed and purified; but if not in a sufficiently clean state after this second washing, it must undergo a third, or even fourth, in the same or smaller hand machines, according to the purity required; which by due and attentive care to the directions herein given, and a little practice, may be carried into any extent required. It is also necessary to observe that the operation of washing and separating ores, or other heavy materials, by the machinery before described, may be effected, (though in a less convenient manner,) without the adoption of either of the bottom central valves, or any valves at all; because such heavy materials, if not permitted to escape by the valves, will accumulate in a heap in the centre of the tub, and will be found upon carefully removing the sand, earth, or matrice from around about it; or another process may be used, such as the apparatus delineated in the subjoined *Fig. 7*, is adapted for,



In this case a shallow tub is set within a deeper and larger one *T*, either with or without the blocks *ll* to raise it above the bottom of the exterior tub; or the inner tub may be fixed in a running stream, or a stream may be made to run continually into and out of it. When the apparatus is arranged in this form, the revolving motion of the agitator *F F I I* will have the effect of throwing out of the water that is introduced with the ore into the shallow tub, over its

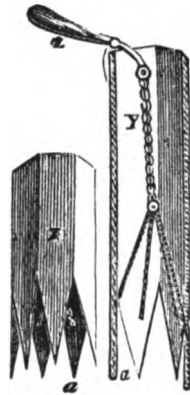


edges into the external tub, or into the running stream, (as the case may be,) or into a reservoir; and with it nearly all the sand, earth, or matrice will be thrown over, so as to leave the ore, or other heavy material, in a nearly clean state at the bottom of the tub, particularly if a sufficient quantity of water has been used during the process.

The whole agitator is now to be removed, for taking out the clean ore, and when an accumulation of refuse has taken place in the outer tub, (if such a one be used,) the inner one is to be removed, and the agitator lowered into the other large tub for stirring up the said refuse and water, while it is drawn off by the plug, or spigot and fauset at S; after which such refuse and water are to be again passed through a machine by way of examination, to ascertain if any ore, &c. had passed over with it; and if so, it will be obtained at this second washing. The refuse and water might be led over coarse flannel or cloth, in which the heavy material would deposit itself, if there be any left in the refuse. It may likewise happen in some cases, that the ore, or other heavy substances, cannot be conveniently broken down and reduced to powder, but may contain diamonds, precious stones, lumps, or fragments which would be too large and heavy to be put into motion with the water, as before described; whenever this is the case, the construction of the agitator, shown in *Fig. 7*, is recommended, which in effect is the same as those already described; but instead of intersecting the arms FF, which carry the stirrers IIII into the central block of wood already described, a circular kind of funnel or hopper is constructed as shown in section at *ggg*, of iron, and the spindle revolves into transverse pieces *mm* within the said hopper; such pieces being placed with their thinnest dimensions upwards, so as to cause as little obstruction as possible. This hopper is to be fed with ore (previously broken into small pieces), by means of the shoot *nn*, which may be shook by joggles at *r*, like a cornmill, or be fed by any other convenient method. *Fig. 7* also shows another form of the agitator: a double set of arms to carry the stirrers, is not essential; all that is necessary is, that it should possess sufficient strength and substance to put the whole of the water and heavy materials mixed therewith, into a sufficiently rapid motion, to produce the conical hollow space similar to *kkk*, *Fig. 3*, as before described.

In addition to the several modes of working the apparatus explained, it is proposed to work the same in streams, or ponds, where gold-dust, ores, &c. may be found, or suspected to exist, without using a tub, in which case the agitator only is to be used, and must be supported, as before, by its cross-bearers DD, and standards CC. *Figs. 1, 2, 3, 5, 6*, being either fixed to the bottom of a boat or punt, or supported between two boats or punts, the same being immovably moored or fixed upon the water; or the machinery may be placed upon a stage with legs, adjustable to the depth of the water, so that the agitator may be put into rapid circular motion as before described; or as near as possible to the bottom of such river or stream, when it will soon, by such motion, remove the soil (provided it is not too hard or strong), and will form itself into a circular hollow space equal to its own diameter, into which space it is to be gradually lowered as the earth is washed away; when, if any gold-dust, ore, or heavy metals are present, they will be brought to the centre thereof as effectually as if the first agitator had been worked in a tub; which done, the position of the central spindle of the agitator is to be worked as accurately as possible, either upon the stage that supports it, or by placing upright straight rods in the ground round about it, when a light metal tube, of tinned or plate iron, open at both ends, and of equal diameter to about one-fourth of the agitator that has been used, is to be lowered over the said central spot, for the purpose of confining and covering whatever may have been so brought to the centre, which may then be raised in the tube, by inserting a pump therein till it reaches the sand; and after having made with it a partial vacuum by raising this pump, the whole tube is brought out with it; or by means of proper ladders, augers, screw-worms, or other implements used for boring the earth, and bringing up the same through tubes for well-sinking, and other well-known purposes; or the implement shown at *Fig. 8* may be used to advantage. It consists of an hexagonal, or other polygonal pipe of iron made nearly to fit and

fill up the inside of the light pipe before mentioned (directed to be lowered for covering and securing the materials); its lower end is to be formed into as many points as the first polygonal has sides, as at *aaaa* in *Fig. 8*; these points should be of steel, not only for durability, but that they may bend inwards and spring open again in the form shown at *X*, in which state the pipe is to be lowered into the tube above mentioned, and it must be pushed through the soil, or whatever the agitator may have brought to the centre, by slackening and turning it round; while, at the same time, the central chain which communicates by branch chains with each of the first points, as seen at *Y*, is to be strained with sufficient force, either by the lever *Z* or in any other way, to bring all the first points *aaa*, &c. together, in which state they will be retained, until the contents thus confined to the pipe are brought up out of the water, and discharged on the boat or platform.



Having now described a variety of processes for obtaining the ores of copper, lead, tin, gold, silver, and some other metals, we will refer the reader to the article *COAL*, (Vol. I. pp. 374 and 375,) where a sectional engraving of a coal mine and iron mine is given, with an accurate description of the mode of working the same. It is an astonishing and highly interesting sight to a stranger in the neighbourhood of Birmingham, and in other coal and iron districts, to behold, at one view, a great number of steam engines, with all their massive machinery and apparatus, simultaneously at work in the open air; some employed in drawing up the iron ore, others coal; which, as they emerge from the earth, are sometimes lifted upon an elevated rail-road, from whence, by their own gravity, or by the aid of machinery, they are conveyed with rapidity to their destination; the contents are instantly discharged, and the emptied skip brought back in continuous succession.

**MINIUM.** A name which was given to what is now called *cinnabar*; it is a native mineral, of a shining red colour, out of which quicksilver is extracted.

**MINT.** The place in which the king's money is coined. Formerly mints existed in almost every country, for notwithstanding the coining of money appears at all times to have been considered a special prerogative of the crown, the Saxon princes ceded the privilege to their subjects to a great extent, reserving at the same time eight mints for the City of London. This arrangement was continued by the Norman kings with little alteration until the period of Richard I., who procured from the east of Germany, persons well skilled in the art, for the purpose of improving the coinage. From this time to the accession of Edward II. A. D. 1307, but small progress appears to have been made. That prince however endeavoured by introducing many alterations in the constitution of the mint, to improve the coinage. From this period a considerable time appears to have elapsed, without any material changes taking place, until the appointment of a Committee in 1798, to consider the establishment and constitution of his Majesty's mint, the result of which was the erection of the present mint on Tower Hill, between 1805 and 1810, with highly improved machinery, and increased facilities for carrying on the process of coining extensively and advantageously. The various chemical manipulations necessary for reducing the metal to its due degree of purity previous to coining, it is not our province to enter into; we shall, therefore, proceed to a description of the different processes of coining, after the metal has been received in the melting house. The usual mode was to melt the silver in black lead pots, and a considerable coinage of tokens for the Bank of Ireland was produced in this manner. The importations being entirely Spanish dollars, and the tokens of the same standard, the melter could easily melt them in quantities of 60 lbs. troy, which was done. But the inconvenience of this mode was ultimately severely felt, because ingots of silver of different qualities could not be used for coinage, from the difficulty of blending several together in one pot to produce the proper

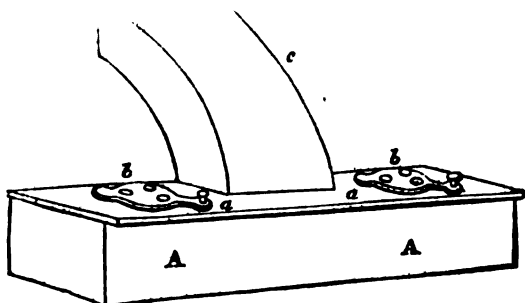
standard of our money. This obstacle was so severely felt that, in 1777, Mr. Alchorne, then principal assay master, was commissioned by Government to visit the mints of Paris, Brussels, Rouen, and Lille, for the purpose of collecting information with respect to the arts of coining as practised in those mints, and more particularly the most approved mode of melting silver in large quantities. Alchorne's intimate knowledge of the English mint, together with his great acquirements as a practical chemist, eminently fitted him for the undertaking; and his observations on the coin and coinage of France and Flanders, are alike creditable to his judgment and knowledge.

It is recorded in the documents of the mint, that at the recoinage of William III. the pots of silver weighed 400 pounds troy, and upwards, and it is somewhat extraordinary, that no trace of the process by which this was accomplished has been found; it is, therefore, mere matter of conjecture that pots of wrought iron were used.

In 1758, some trials for melting silver in wrought iron pots took place, by means of a blast furnace, but they were found so inconvenient, laborious, and profitless, as to cause the process to be abandoned. In 1787, some new experiments were tried by Mr. Morrison, (then deputy master and worker,) who conducted the meltings. A blast furnace was again tried and again abandoned. He next attempted to melt the silver in large black lead pots, containing from 100 lbs. to 120 lbs. troy; but the repeated breaking of these pots, although guarded on the outside with luting, proved a great interruption to the business, and serious loss to the melter. Trial was likewise made with cast iron pots, but these were found subject to melt, and the iron consequently got mixed with the silver. The work too was continually stopped by the king's assayer, the metal not being of the proper standard, in consequence of being refined by the process of melting, and lading it with ladles from the pot.

Great difficulties likewise were experienced in blending ingots of different qualities so as to produce the proper standard, the pots not being sufficiently large to contain the larger ingots of 60 to 80 lbs. troy, when blended together. It was therefore obvious that this mode of conducting the silver meltings was exceedingly defective, and was in consequence abandoned. Experiments were then tried with a reverberatory furnace, built after the model of those used in the Lille mint, but with no better success; and the process was, as in former cases, abandoned. The principal obstacle here appears to have been the great refinement of the silver in the melting, by the oxidation of the alloy. In 1795 and 1798 further trials were made by Mr. Morrison, for the purpose of overcoming this apparently insurmountable difficulty. In these experiments he tried three furnaces of different constructions, and although he accomplished much towards his object, there remained still a serious imperfection, arising from the process of dipping out the metal from the pots with ladles, which in addition to chilling the metal, was exceedingly laborious, and fraught with many disadvantages. In 1803 Mr. Morrison died, without bringing the process of melting silver to that degree of perfection which, had he survived, by the activity of his intellect, great knowledge of his subject, and unwearied perseverance in its prosecution, he would, doubtless, have accomplished. His son, who succeeded to his situation, appears to have inherited his father's active and intelligent mind; for in a short period he so successfully exerted himself for the accomplishment of the object sought to be attained, that by the construction of a furnace adapted for the use of cast-iron pots, the use of pots of a size capable of melting from 400 to 500 lbs. troy at one charge, the adoption of such machinery as would supersede the clumsy and wasteful process of lading the silver from the pots when melted; and lastly, the introduction of the use of moulds made of cast iron, in place of those then used, which were made of sand, the process of melting silver, so far from being a laborious, troublesome, and expensive process, became simple, and efficient in operation, and capable with ease of melting 10,000 lbs. troy of silver daily. The illustration opposite exhibits a perspective view of the furnace at present in use. *A A* are the furnaces in which the metal is melted. These are the air furnaces, built of fire brick, in the usual manner of melting furnaces, but to render them more durable, the brickwork is cased in iron plates, which are put together by screws. *b b* are the covers to the fur-

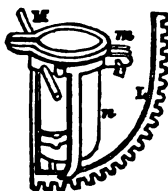
aces; they are held down to the top plate by a single screw pin for each, and on the opposite side of the cover a handle *a*, is fixed; by pushing this handle, the cover is moved sideways upon its centre pin, which leaves the furnace open; a roller is fitted to the cover, to run upon the top plate, and render the motion easy. The interior of each furnace is circular, 30 inches deep, and 21 in diameter; the bottom is a grate of cast iron bars, movable for the purpose of admitting air. Upon the grate is placed a pedestal or stand of cast iron, of a concave shape, covered an inch thick with coke or charcoal dust, upon which the melting pot is placed; the pedestal is nearly two inches thick, and is fully two inches broader in diameter than the pot, the object of which is to protect the hip of the pot from the intense heat which the current of air ascending through the grate when the furnace is at work creates, and which might otherwise melt it. On the top or mouth of the pot, is placed a muffle, which is a ring of cast-iron, six inches deep, made to fit neatly into the pot; the use of this muffle is similar to that used in melting gold, to give a greater depth of fuel in the furnace than the mere length of the pot, and which adds materially in ver-



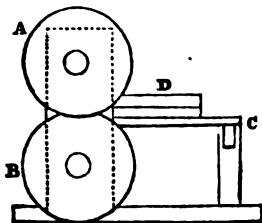
fecting the process. The muffle likewise, by rising above the pot, enables ingots of silver to be charged, which are longer than the depth of its interior. The top of the muffle is covered with a plate of cast iron, to prevent the fuel from falling into the pot, and secure the metal from the action of the atmospheric air when in fusion. Each furnace is provided with a flue, which proceeds in a horizontal direction, and extends to the flue *c* which is carried up in a sloping direction to the stack or chimney.

When the furnace-covers *b b* are closed, the current of air which enters at the grate ascends through the body of the furnace, and causes the fuel, which is coke, to burn with great intensity around the melting pot. The degree of heat is accurately regulated by a damper, fixed in the flue of each furnace. When the furnace is put to work, it is lighted by some ignited charcoal being put upon the grate, and around the pot, (for the melting pot is always in its place before the fire is lighted;) upon the charcoal about three inches depth of coke is placed; the cover *b* is shut, and the damper is withdrawn about two inches. When the coke is ignited, a similar quantity is added, and so continued until the furnace is filled with ignited coke. The object of this precaution is to prevent the cracking of the melted vessel by being too suddenly heated. Before the silver is charged, the pot is heated to a bright red: it is then carefully examined to ascertain if it has successfully withstood the action of the furnace, or cracked during the operation. The silver is then placed in the pot, accompanied by a small quantity of coarsely grained charcoal powder,—which by coating the inner surface of the pot, prevents the silver from adhering to it. When the silver has attained the fusing point, the quantity of charcoal is increased, until about half an inch thick on the surface of the silver, which preserves it in a great measure from the action of the atmosphere, and prevents that destruction of the alloy which was found so great a difficulty in the earlier processes of coining. When the silver is completely and properly melted, it is stirred with an iron stirrer, in order that the whole may be of one standard

quality. The vessel containing the molten silver is then lifted from the furnace by means of a powerful crane, to which are suspended hooks, or claws, which firmly clutch the rim of the pot; which being raised a sufficient height from the furnace, is swung round by the gib of the crane, that it may be brought over the pouring machine, of the principal portion of which the following engraving will convey an adequate idea. A is an axis to which is affixed a cradle, which receives the pot. The cradle is so constructed as to open and shut, and the screw *b* draws the parts together till they fit. Forming a continuation of the principal bors of the cradle, is the arched rack, C. When the cradle is in its place, the rack is engaged by a pinion, and can thereby be elevated to pour the metal by means of a lip, or spout, made in the edge of the pot for that purpose, into the ingot moulds. D is the melting pot, firmly embraced by the cradle, preparatory to filling the moulds, which are composed of cast iron, the upper edge of the mouth being slightly enlarged, to facilitate the reception of the metal. A row of these moulds are placed in a carriage, and screwed tightly together, at the same time resting on a plate, which can be raised or lowered, as the difference of size in moulds may require. The carriage is supported upon four wheels, and runs upon a railway, by which means the moulds are brought in regular succession under the melting pot, which by means of the arched rack C, is lowered to allow the molten metal to escape freely until the moulds are filled.

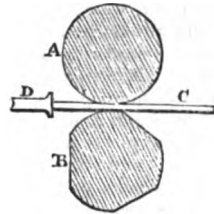


The next process to which the silver is subjected after being taken from the moulds, is that of flattening, rolling, or laminating in the rolling mill. For the purpose of facilitating this process, the bars, or plates of metal, are heated to redness, by which a much greater degree of extension is obtained by the same amount of power than could be otherwise accomplished. Gold bars do not require to be so treated, they being rolled out while cold with great ease, to the thinness of a half-sovereign, without the least symptom of cracking: this is easily accounted for by the difference in the constituent particles of the two metals—gold and silver. The rolling mill is put in motion by a powerful steam-engine, which, by a judicious and beautiful arrangement of mechanism, causes two rollers to revolve in opposite directions, and then their adjacent surfaces will move together, between which the silver to be rolled, or flattened, is introduced. Connected with the mill there is also a gauge, or scale, to ascertain the thickness of the plates which have undergone extension by means of the rollers. It consists of two steel rulers fixed fast together at one end, the other end being a certain distance asunder, forming an opening between them gradually diminishing to nothing; the sides of the rulers are divided, and in using, to determine the thickness of a piece of plate, the edge of the metal is applied to the opening between the rollers, and the engraved divisions show the distance it will go into the opening before fitting tight. After the completion of this process, it becomes necessary that the metal should be cut into uniform slips, of a convenient width for cutting out the circular pieces or blanks, which are to form the coin: this width being generally that of two crowns, two half-crowns, and two shillings. This is accomplished with accuracy and precision, by passing the metal between two cutter-wheels, as exemplified in the annexed illustration. A and B are the circular cutters, the edges of which lie in close contact laterally, and overlap each other a little; they are turned very truly circular, and are, on the whole, constructed with great care and nicety. The edges are formed of hardened steel, and whilst revolving, if the edge of any piece of metal be presented to them, it will be cut, or divided, in the same manner as by a pair of shears. C is a narrow shelf, upon which the plate is supported when pushed forward to be cut and D is a



guide, fixed upon the shelf, against which the edge of the plate of metal is applied whilst it is moved forward to the circular cutters, and which, by being movable, determines, by the distance which it stands back from the cutting edges, or line of contact of the cutters, the precise breadth of the slip of metal which will be cut off. To give these slips of metal the exact thickness requisite before being cut into blanks, they are subject to a more delicate rolling, or are drawn between dies, by an ingenious and efficacious modification of the great rollers, invented by Mr. Barton, the present comptroller of the mint.

Mr. Barton has, likewise, brought into successful operation a new machine for drawing the metal between dies, in a similar manner to that in which wire-drawing is accomplished, by which a greater degree of accuracy and uniformity is obtained in the thickness of the metal. It is, however, necessary, before this operation can be accomplished, that the ends of the slips of metal should be thinned, that they may enter, with ease, the drawing, or elongating apparatus; for which purpose they are passed between rollers, the construction of which the annexed figure will explain. A is the upper roller; B the lower, which has three flat sides; C is the piece of metal placed between the rollers; D is a stop, adjustable in the line of the motion of the slip of metal C, which is presented to the rollers when they are in such a position that one of the flat sides of the lower roller is opposite the upper, then the piece of metal can be pushed forward between the two until prevented by the stop D; as the rollers then revolve, and the flat side passes by, the cylindrical parts will take the metal between them, and roll it thinner at the end which is between the stops and the point of contact of the rollers. This thin portion of the slip of



metal is then introduced between the dies, which are two steel cylinders made very hard and true. These dies are attached to one extremity of the drawing, or elongating machine, which is provided with endless chains, to which are attached tongs similar to those used in wire-drawing, which grasp the metal slip with great force, drawing it through the dies as the endless chain performs its revolution. This machine, although important in its result, and apparently exercising a great power of action, is, with but little labour, rendered available for the purpose for which it was intended, by the trifling muscular energy exercised by two boys, who conduct its operations. At the mint there are two of these machines, by means of which the pieces of metal are brought more nearly to the standard weight, which is an object of considerable importance.

The next process to which the silver slips are subjected, is accurately and efficiently performed by Mr. Bolton's cutting-out press, for which he obtained a patent in 1790. This press differs not materially from those in use at most foundries. Twelve of them are at the Royal Mint, arranged in a circle around a large wheel, which is turned by a steam engine, and has a fly-wheel fixed on the same axis, just above the wheel, to regulate the motion, the whole presenting a pleasing and commodious arrangement of machinery. The round pieces of silver, or blanks, are, after being cut out by the Bolton press, carried to the sizing-room, where each individual piece is adjusted to its standard weight. The light pieces are selected for remelting, and the heavy ones (if not considerably beyond weight) are reduced to their standard weight by rasping their surfaces with a rasp, or file. The accuracy and efficiency of Mr. Barton's machine for drawing the metal between dies, has considerably abridged the labour of this inelegant and unmechanical process. The pieces thus adjusted are in a state of great hardness from compression by the rolling and drawing processes, and by which, in fact, a great portion of their latent heat has been squeezed out. They attain their softness again by being heated to a cherry red, in a reverberatory furnace; after which they are boiled in dilute sulphuric acid, which makes them very clean, and of a white colour. When dried either in warm saw-dust, or over a very slow fire, they are in a fit state for the two next processes, which are the milling, and the coining, or stamping.

The operation of milling is performed round the edges of the pieces of money to prevent their being clipped or filed, which was a fraud commonly practised upon the ancient money, made before the introduction of milling or lettering round the edges. The construction of the milling machine is simple, but efficacious. It consists of two rulers, or steel bars, which are accurately cut, or fluted, and, by the aid of a simple combination of mechanical contrivances, so placed that although the lower one is immovable, the upper has a horizontal motion, carrying the piece of money with it, which is placed edgeways between the two, the grooves, or flutes, in the steel bars, forming corresponding indentations and elevations, on the edge of the coin.

The next, and last operation, which remains to be performed to complete the process, is that of stamping the effigy, or impression, upon the hitherto blank pieces of silver. This is accomplished by the coining press, of which there are eight in the Royal Mint. They are worked by a steam engine, which communicates its power from an adjoining room, by means of connecting mechanical arrangements. Both sides of the piece of money are stamped by one stroke of the press. The blank piece of metal being placed flat upon the lower die, which is immovable, is then forcibly struck by the upper die, which, at one stroke, produces the impression. The piece of blank coin is contained within a steel ring, or collar, whilst being stamped, which preserves its circular figure. There is, likewise, connected with this machine, a beautiful arrangement of mechanical power, by which, when one piece of metal is struck it will be removed and replaced by another. This is accomplished through the agency of the same power which puts the press in action, and consists of an arrangement of levers and other mechanical contrivances.

The process of coining is now accomplished. Throughout this short notice we have mentioned silver as the metal coined into money by the beautiful and efficient machinery to which we have directed the attention of our readers; and, by so doing, we have embraced almost every process to which the other metals used for the same purpose are subjected; the operation, in every case, being, with a few trifling exceptions, the same. We may now truly say that the art of coining has arrived at that degree of perfection, that its farther improvement has ceased to be the object of national importance, which, in earlier ages, it must have appeared. But still there cannot be a doubt, that, considering the rapid strides which the physical sciences are making towards perfection, many years will not elapse before we may look back upon some of those combinations of mechanical skill and ingenuity which we have been accustomed to consider as preeminently excellent, as things which have been, having given way to more perfect efforts, which, in their turn, may, perhaps, upon the discovery of some entirely new moving power, be considered cumbrous and unskilful efforts of human industry.

**MIRROR.** A surface of polished metal, or of glass, silvered on its posterior side, capable of reflecting the rays of light from objects placed before it, and exhibiting their image. There are three classes of mirrors, distinguishable by their reflecting surfaces; namely, *plane*, *concave*, and *convex*. The reflection of light by mirrors observes the invariable law, that the angle which the incident rays make with the reflecting surface is equal to the angle of reflection.

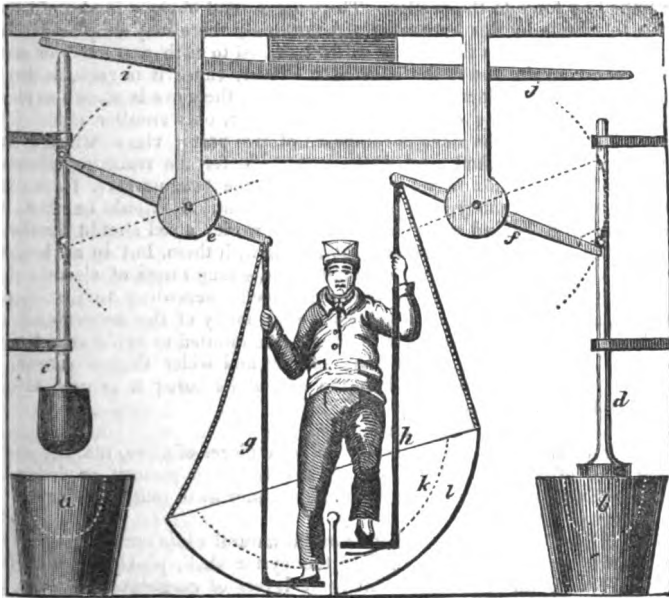
**MOORINGS** are an assemblage of anchors, chains, and bridles, laid athwart the bottom of a river or harbour, to ride the shipping therein. These anchors have generally but one fluke, which is sunk in the river near low-water mark. Two anchors, being thus fixed on the opposite sides of the river, are furnished with a chain extending across, from one to the other; in the middle of which is a large square link, whose lower end terminates in a swivel, to which are attached the bridles, which are short pieces of cables well served, whose upper ends are drawn into the ship, and secured to the bits, &c. By these means the vessel veers round easily, according to the change of the wind or the tide; in some places, however, particularly on rivers, each ship takes in a bridle astern, also, by which she becomes moored head and stern.

**MORTAR.** A cement made of lime, sand and water. See **LIME**.

**MORTAR.** A strong hollow instrument, usually made of marble, Wedge-

wood ware, or metal, in which hard or brittle substances are pulverized by percussion or grinding with another instrument called a *pestle*. Mortars usually partake of the shape of an inverted bell, but their form, capacity, and solidity, as well as the material of which they are made, vary with the object for which they are mainly designed. Thus, they may be purchased ready made, from an inch to eighteen inches, internal diameter, varying in weight, from an ounce or two, to several hundredweight. Large mortars are usually fixed upon a block of wood, of such a height, that the mortar may be level with the middle of the operator. When the pestle is large and heavy, it is sometimes suspended by a cord or chain, attached to a moveable pole placed horizontally above the mortar; this pole considerably relieves the operator, owing to its elasticity assisting the raising of the pestle.

In the annexed diagram is represented a plan for economizing the labour of pounding and sifting, which has been recommended by a person of practical experience in those operations. *a* and *b* are two large mortars, containing the material to be reduced; *c* and *d* are the pestles, with their rods; *e* and *f* are two levers suspended at their fulcrums to a simple frame to the ceiling, connected



at one end by joints to the ends of the pestles; and by the other end, in a similar manner, to descending rods attached to treads, which are operated upon alternately by the man in the centre stepping from one treadle to the other. In this manner a force of 150 lbs. is applied to one end of each lever in succession, and would consequently raise a similar weight at the other, if the fulcrums were in the centre. As it is however, desirable that the man should not have to step up high in lifting his weight from one treadle to the other, and as a pestle of fifty pounds weight is very considerable, those ends of the levers which are attached to the treadles are shortened, so as to make the force about 120 lbs. This loss of power, in the first instance, is however fully compensated for, by the pestles being raised higher in the same space of time, or with greater velocity, and the increased momentum with which they (alternately) strike the



springs *i, j*, in the ceiling, is returned by the action of the latter upon the substance in the mortars. When one of the pestles has struck, the man steps off that treadle which operates upon it, on to the other: the long arm of the lever of the former then descends by its superior weight, and being jointed near the extremity, it passes by the pin on the rod, (which should have an anti-friction roller upon it,) by the joint opening, as shown in dotted lines, and afterwards closing, it locks itself under the pin. In its re-ascend it then takes up the rod and pestle, and allows them to drop when it has passed beyond the sphere of its action, as shown on the opposite side, where the lever is exhibited as being just beyond the point of contact, and the pestle is about to return to the mortar with all its accumulated force. Underneath each treadle, a strong steel spring is fixed, to prevent those shocks which the man might experience by the treadles striking against the floor, after the levers have passed the rollers on the pestle rods; and the reaction of these springs is attended with the further advantage of assisting the man on to the other treadle.

It is apparent that by this method of pounding, a surplus of power, amounting to about 70 lbs. is devoted to the giving an accelerated force to the pestle. If we then take away a small portion of this surplus power for the purpose of sifting, it may so well be spared, as to make a scarcely perceptible difference in the impelling force to the pestles. There are several obvious modes of causing sieves to vibrate by this apparatus. Accordingly there may be placed a large semicircular sieve on a floor, with cords attached to each extremity or corner, which being made fast to the ends of the lever, cause it to rock, as they are alternately raised or depressed. In the drawing, the sieve is shown as moving upon a central bearing or pivot; this is, however, only another mode of producing the effect. The sieve is composed of two parts; viz. *k*, which contains the material to be sifted, and *l*, the receptacle for the resulting product or powder. The situation of this sieve between the two mortars, for receiving their contents alternately, will be found convenient. It should be placed at a suitable distance behind or before the man at work; a rod should therefore be fixed to the end of each lever, at right angles with them, but in an horizontal position, which it would always maintain; and a long range of sieves, separate or connected, may be moved by the same means, according to the length of the horizontal rod. In the foregoing drawing, many of the subordinate parts, which every engineer knows how to supply, are omitted to avoid complexity.

**MORTAR.** A piece of artillery, shorter and wider than a cannon, and having a powder chamber less than the size of its bore; it is used to throw bombs and shells into fortified places.

**MOSAIC GOLD.** See **AURUM MUSIVUM.**

**MOSAIC WORK.** An assemblage of little pieces of glass, marble, precious stones, &c. of various colours, cut to a determined pattern or design, and cemented on a ground of stucco, in such a manner as to imitate painting. See **MARQUETRY.**

**MOTHER OF PEARL,** is that beautiful natural white enamel, which forms the greater part of the substance of the oyster shell, particularly the pearl oyster. It is found to consist of alternate layers of coagulated albumen, and carbonate of lime.

**MOTHER-WATER,** is the uncrystallizable residue of a compound saline solution; thus the liquor left in a salt pan, after the salt is taken out, is the mother-water.

**MOULD.** A general term applied to a great variety of implements employed in the mechanic arts. Thus with a shipwright, a mould signifies a thin flexible piece of wood, on which the required curves of the timbers are truly cut out. *Moulds*, in the manufacture of *paper*, are the frames in which the sheets of paper are moulded; see **PAPER MANUFACTURE.** *Bullet moulds*, are similar to iron pincers in their handles and joint, but the jaws are solid, each containing a hemispherical concavity, which, when closed together, form an entire sphere, leaving a small hole or jet through which the melted lead is conveyed. *Glasiere's moulds* are of several forms, for casting the strips of lead, which are afterwards drawn through their vice. *Candle moulds* are used by the

tallow-chandlers, for casting their mould candles in. The term mould is indeed of such general application to patterns for working by, and to various tools containing hollow cavities, either for casting in or producing various forms by percussion or compression.

**MOULDINGS.** Any thing that has been cast in a mould, or has that appearance; in architecture, the term is applied to the ornamental projections from a wall or column, &c.

**MOWING MACHINE.** An agricultural implement, designed to supersede the use of scythes by hand. Many have been made at different times, but the difficulty of adapting them to the ordinary unevenness of the surface of the fields, has, we believe, caused their general abandonment; but it is not improbable they will ultimately be brought into use in many situations. In a model of one of these machines, which is placed before us, a circular knife or knives are attached to the periphery of a wheel, which revolves horizontally between the running wheels of a light carriage; the axis of the running wheels communicating the motion to the horizontal cutting wheel, through the medium of bevelled gear. The height of the cutting wheel from the ground is regulated by means of a lever and weight; and the machine is forced forward by a horse yoked behind it. For mowing grass plots, a beautiful machine has been invented and matured by Mr. Budding. See GRASS in the work; also a model of the machine in the Museum of the Mechanical Arts, in Leicester-square.

**MUCIC ACID.** This acid has generally been known by the name of *sacchaloctic*, because it was first obtained from sugar of milk, but all the gums appear to afford it readily.

**MUCILAGE.** A general term, denoting any viscid or glutinous liquid; but chemically speaking, it is understood to apply only to an aqueous solution of gum, or mucilaginous extract of vegetables.

**MUFFLE.** A vessel employed in metallurgic operations. In figure it represents an oblong arch or vault, the hinder part of which is closed by a semi-circular plane, and the lower part, or floor, is a rectangular plane. It is a little oven, that is placed horizontally in assay and enamelling furnaces, so that its open side corresponds with the door of the fire-place. Under this arched oven, small cupels or crucibles are placed; and the substances contained are thus exposed to intense heat, without contact of fuel, smoke or ashes.

**MULE.** A machine employed in spinning cotton and other fibrous materials. It was invented by Crompton, in 1779, and was found to produce finer yarn than was spun by the machine previously in use. For producing fine threads, a process analogous to that performed with carded cotton, upon a common spinning wheel, and called *stretching*, is resorted to. In this operation, portions of yarn, several yards long, are forcibly stretched in the direction of their length, with a view to elongate and reduce those parts of the yarn which have a greater diameter, and are less twisted than the other parts, so that the size and twist of the thread may become uniform throughout. To effect the process of stretching, the spindles are mounted upon a carriage, which is moved backwards or forwards across the floor, receding when the threads are to be stretched, and returning when they are to be wound up. The yarn produced by mill spinning is more perfect than any other, and is employed in the fabrication of the finest articles. The sewing thread, spun by mules, is a combination of two, four, or six threads. Threads have been produced of such fineness, that a pound of cotton has been calculated to reach 167 miles. See COTTON and SPINNING.

**MULLER.** A tool employed for holding or grinding substances upon a stone. The glass-grinders thus call the instrument used for grinding their glasses, which consists of a round piece of wood, about six inches long, to one end of which is cemented the glass to be ground, whether convex in a basin, or concave in a sphere. For grinding colours, the muller is of stone, and is usually employed upon a flat slab of stone; as may be seen in most painters' and colourmen's shops. An improvement upon this plan was, however, introduced by Mr. Rawlinson, for which the Society of Arts awarded him their

silver medal. As this machine is said to have been proved, by many years' experience, to be more effectual and expeditious in grinding colour to that extreme fineness required by artists, and to be less prejudicial to the health of the workman, we shall here add a description of it.

The machine consists of a short cylinder of black marble, 16½ inches in diameter, and 4½ in thickness, turned vertically on its axis by means of a winch. A concave piece of marble is provided, of the same breadth as the circular stone, and forming a segment of the same circle, one-third of the circumference in extent; this segment, which may be considered as the muller, is fitted into a solid piece of wood of a similar shape, one end of which is secured by a hinge, or otherwise, to the frame; the other end rising over the circular stone, and supported by it, is further pressed down on it by a long spring bent over from the opposite extremity of the stand, and regulated as to its pressure by a screw, whose end turns against the concave muller. A slight frame of iron in front, moveable on a hinge, supports a scraper, formed out of a piece of watch-spring, which takes off the colour, and is turned back out of the way when not in use.

**MURIATIC ACID.** See **ACID, MURIATIC.**

**MUSK.** A strong perfume, obtained from an animal of that name

**MUSKET.** The fire-arm of the common soldier.

**MUSKETOON.** A short thick kind of musket; also called a blunderbuss.

**MUSLIN.** A fine sort of cotton cloth, first imported from India, but now for the most part manufactured in this country.

**MUST.** The unfermented juice of the grape.

**MYRRH.** A gummy, resinous, concrete juice, which issues by incision, and sometimes spontaneously, from the trunk and large branches of a tree, growing in Arabia, and Egypt, especially in Abyssinia. It consists of one-third resin, and two-thirds gum.

## N.

**NAILS** are small spikes or pegs of metal, usually of iron, extensively used in building, and generally in the constructive arts. From the immense quantities of nails made in this country, the manufacture may be deemed one of first-rate importance; for, in the neighbourhood of Birmingham alone, upwards of 60,000 persons, men, women, and children, are occupied in their production; and many of the iron-works in the same district furnish from 100 to 200 tons weekly of "split-rods," of the various sizes and qualities required in the making of the nails (see **IRON**). The workmen who forge the nails are called "nailors;" women, boys, and girls, are likewise employed in the same kind of work; and it is very common to see a whole family working together. Each individual usually confines himself, or herself, to a certain peculiar class of nails, who, consequently, acquires a great degree of expertness and celerity in their production, not to be equalled by those nailors who have been habituated to forge other kinds.

Under the article **FORGE** we have given a drawing and a description of a nailor's forge of the most improved description; we have, therefore, only to notice the other tools employed in the art. These are, a small steel anvil, which is inserted in a massive block of cast-iron; and this latter is usually imbedded in slack, so that the steel anvil only is seen. The hammers used are, of course, proportioned in weight to the size of the nail, and the shapes vary considerably, according to the ideas of the workmen; but they are usually the frustrums of cones, the smaller ends of which constitute their faces; the planes of which are not parallel to the handles, but inclined to them. A nailor keeps constantly several rods in the fire, which he takes up in succession as they become hot, so as not to have to wait for a heat. When the shank of the nail has been drawn out to the required form and length, it is nearly cut off the rod by striking it over a fixed chisel, and is then inserted into the heading tool, from which the rod is then

broken off; the nail is then headed in the tool, and turned out of it by turning it upside down, and striking it upon the anvil. Such is the celerity with which these operations are performed, that there are instances of nailors making as many as 3000 nails, of three inches in length, in a day, and continuing to work at this rate for many days in succession. Every such nail requires, at the least, twenty-five blows of the hammer to form it, besides two or three blasts of the bellows; nevertheless, the work proceeds at the rate of three or four per minute!

In contemporary publications (the *London* and *British Cyclopædias*) we observe it is stated, that the *forged* wrought-iron nails we have been speaking of have been superseded by the introduction of those made by pressure and percussion in machines. But this statement is extremely incorrect, as every person acquainted with this department of art well knows. The fact is, we believe, that the forged nail manufacture has considerably *increased*, notwithstanding there is a very great demand for the cut or pressed nails, which are preferred in some few departments of art, on account of their uniformity, and their square points; and in some others, by reason of their greater cheapness than forged nails. It should be understood that there are three leading distinctions of iron nails, as respects the state of the metal from which they are prepared; namely—

1. *Wrought*, or *forged* iron nails, being worked out entirely by the hammer from rods, or bars.

2. *Cut*, or *pressed* iron nails, which are stamped, or pressed, out of strips of plate-iron.

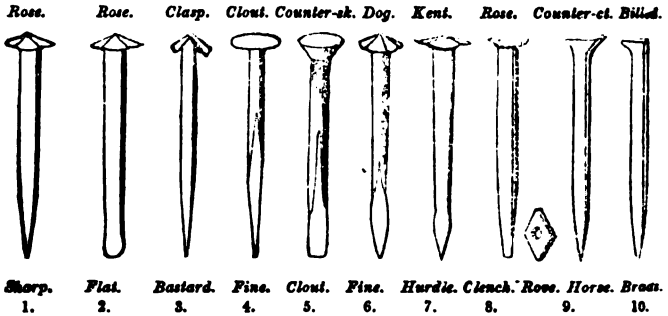
3. *Cast* iron nails, in which the metal is melted, and cast in forms of the precise shape of the nails made.

Forged nails are made of three distinct qualities of iron, that is, more or less refined, or tough, according to the purposes for which they are designed. The very best quality is employed for horse-shoe nails, to admit of their being drawn out very fine, and prevent their breaking in the hoof. Wheelwright's nails, which are forcibly nailed against the iron tire, and the clouts, also require the metal to be very tough. In like manner, hurdle-nails require good iron, that the points may clench soundly, and their broad heads not be broken off. The finer or smaller kinds of nails, being much drawn under the hammer, must also be of good iron; and, indeed, all such where great stability is of essential importance. It would, probably, be good policy in the consumer to have all nails made of at least the second best, or medium quality of iron; but the great competition by the manufacturers to render them as cheap as possible, leads to the employment of a very inferior quality of nail rods for making the majority of nails, of which immense quantities are always in demand for the home trade, as well as for exportation to all parts of the world.

Of the wrought, or forged iron nails, there are about 300 sorts, the forms of which are known to the trade by certain specific names, which, for the most part, express the uses to which they are applied; as *hurdle*, *pail*, *deck*, *scupper*, *mop*, &c.; but there are others whose applications are so general that they are distinguished by certain technical names, expressive of their form; thus—*rose*, *clasp*, *diamond*, &c., explain the form of their heads, and *flat*, *sharp*, *spear*, &c. their points. The thickness of any specified form is expressed by the terms *fine*, *bastard*, *strong*. The length of some kinds of nails is directly expressed by their lineal measure; but their length is more usually comprehended by the number of pounds or ounces a thousand of them weigh. Thus the simple denomination "7 lb. rose," implies a rose-headed nail with a sharp point, weighing about 7 lbs. to the thousand, and measuring about 1½ inch in length. New rose nails are made from 1½ to 40 lbs. per thousand; in all, about thirty different sizes; and taking the various sizes of other nails (which are not so numerous), we may compute the average number of *sizes* of each sort at 10, which, multiplied by 300, the number of sorts before mentioned, makes 3000 distinctive names to nails, all of which are immediately and precisely understood by persons engaged in the trade. The terms employed by retailers, of fourpenny, twopenny, &c., are very undefined as respects the kind, as well as the precise size, these varying with the locality wherein they are sold. To enter into

a detailed description of all the varieties we have named would be tedious and uninteresting to the generality of readers; but impressed with the universal utility of more information than we have already given, we shall proceed to a very condensed and systematic view of their peculiarities and uses.

It has been explained how the various sizes and thicknesses are distinguished, it will only be necessary to show the principal distinguishing forms, without regard to actual dimensions. For convenience, therefore, the several kinds delineated in the following engravings are represented as of one size; and the words printed above and under each, are their proper names.



The first described kind, *rose-sharp*, are very extensively, and almost universally, used for coopering, fencing, and a great variety of coarse purposes, in which hard wood, such as oak and beech, are used. There is, however, a thinner sort, called *fine-rose*, of which prodigious quantities are sent to Canada and other parts, which are used in pine and other soft woods, their broad spreading heads being calculated to hold the work down. The rose, with flat or chisel points, are employed in preference to the sharp, where the wood is in danger of being split by the driving in of the sharp points, which act as wedges, while those with flat points being driven with their edges across the grain, prevent the splitting effect, and hold faster. For these reasons spikes are uniformly made with flat points, from 4 to 12 inches in length, unless ordered to the contrary, for the Brazil market, or other parts of the world, where they may be required for much harder woods than any of our own country.

Of the third sort, *clasp*, there are three distinct thicknesses,—fine, bastard, and strong; and of each numerous sizes. These nails are those commonly used by the London and other house-carpenters, in deal and similar woods; their heads are made projecting downwards, so that when they are driven home flush, their heads stick into the wood and clasp it together, thus checking, to a certain extent, any disposition in the wood to split open; their heads are, in smooth work, driven below the surface, so as afterwards to admit a plane over them.

Of the fourth sort, *clout*, there are, also, three thicknesses of the form of that shown; namely, fine, bastard, and strong; besides numerous sizes. They are much used for nailing iron work, and various substances to wood: they have a flat circular head, round shanks, and sharp points.

There is, however, another kind of clout, extensively used by wheelwrights and smiths, called *counter-clout*, the form of which is delineated in the fifth illustration, which shows that they have counter-sinks under their heads, and chisel points; they are usually made of tough iron, to bear the battering they receive in nailing down the stout iron work for which they are designed: they are made from 1 inch up to 4 inches in length, and of any required thickness.

The sixth figure of the foregoing sketches, is denominated *fine-dog*, in contradistinction to *strong*, or *weighty-dog*, the difference being merely in their proportionate thickness; these are made from 1½ to 5 inches long, and are used for similar

purposes to the last mentioned, as well as others, where the heads (which are very solid, and slightly countersunk,) are not required to lie flush with the work; their shanks are round drawn, and their points speared, which adapts them for piercing and clenching well.

The seventh nail is called *Kent-hurdle*, probably from having been first used in Kent of that peculiar form: has a broad, thinnish rose-head, a clean-drawn, flat shank, a good spear-point, well adapted for nailing and clenching the oaken bars of hurdles together. There are several kinds of hurdle-nails differing from these, but in points so immaterial as not to require notice in this article. *Gate-nails*, which are nearly allied to them, are similar in form, but are usually made stouter: they are made of various lengths.

The eighth of the foregoing figures, *rose-clench*, is a class used for ship and boat building, of which there are several varieties, and numerous sizes. For the former purpose they are much employed in nailing on the wood sheathing, which is soft, and liable to split, unless bored; and as the nails have no points, the ends being left square, they punch out their own holes, driving a portion of the wood before them, hold very fast, and render boring unnecessary. For the latter reasons clenched-nails are now extensively used in the making of packing-cases and boxes, it being found, by experience, that this form holds much firmer when driven in the direction of the grain of the wood, than tapered or pointed nails. The term *clench* is, however, derived from the mode of employing them in boat-building, in which they are clenched, either by battering down the extremity with the hammer, or, preferably, by placing over the extremity a little diamond-shaped plate of metal, as shown in the drawing, and called a *rove*, and riveting the end of the clenched-nail down upon it, which draws the planks, &c. of the boat very firmly and durably together. We are surprised that this simple, cheap, and admirable mode of fastening, should be almost wholly confined to boat-building.

Fig. 9 represents the *horse-shoe* nails in general use; formerly the heads were made square, which are now nearly disused, the preference to the counter-sunk being chiefly given on account of their lying flush in the groove made for them, and more securely attaching the shoe to the hoof.

Fig. 10 represents one of a large class of very useful nails, called *brads*; they are made of various thicknesses, according to the strength of the work, and varying in length from  $\frac{1}{2}$  to 3 inches.

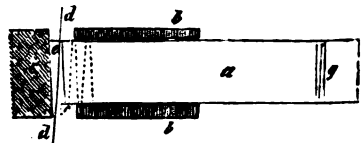
*Deck-spikes* do not have rose-heads, as they would leave greater holes in the surface; but either a neat, square, flat head, that beds in flush with the surface, or a clasp or diamond head, as shown in Fig. 3. *Scupper-nails* have extremely broad heads for fastening down the lead linings. *Sheathing-nails*, of the ordinary kind, are stout, flat, pointed nails, with clasp heads. There are also peculiarly formed nails for the rudders, the ribs, and various other parts of ships. The nails used in barge-building are chiefly very broad and flat in the shanks, with chisel points. *Pound-nails* are extensively used in Essex, Suffolk, and Norfolk; their form will be understood by reference to the *rose-sharp*, which they resemble in form, but are made stiffer, and with better and more solid heads; they are excellent for coarse, strong work, such as field-fencing, in oak.

*Tacks* are also a very numerous and useful class of nails; they are technically divided into rose-tacks, Flemish-tacks, and clout-tacks; the Flemish-tacks, however, chiefly obtain; and the heads of these are "Flemished," that is, not raised so much as a rose-head, nor so flat as a clout-head. The sizes of these are from an eighth to three-quarters of an inch in length; or, as they are denominated, from 1 oz. to 16 oz. per thousand. The chief place of manufacture for these, and other very small kinds, is Bromsgrove, in Worcestershire, where it is a common feat of the work-people to forge a thousand (1200) tacks so small as to easily fill the barrel of an ordinary goose-quill, the weight of the tacks being about 20 grains.

We could extend our description to numerous other denominations of forged wrought-iron nails; but as these, for the most part, differ in merely unessential points from those we have explained, we shall next proceed to the consideration of—

*Cast-iron nails.* These, from their great brittleness, are applicable to comparatively few purposes, such as garden-walls, the lathing of plasterers, coarse shoes and boots, &c.; and they are desirable for those purposes merely on account of their great cheapness. It should, however, be observed, that cast-iron nails are made of three distinct qualities, two of which are produced by annealing processes subsequent to that of casting. In the state the nails come from the moulds, they are so extremely brittle as to be only applicable to shoes, and those only of the very small short kinds, called sparrow-bills. The cast nails for the use of plasterers, as well as those for garden-walls, and those of similar sizes, undergo a process of annealing to prevent their flying into pieces on being driven by a hammer. The best sort of cast-iron nails are called "malleable cast-iron," from their actually being rendered partially so by a long continued process of annealing; but the metal used for this purpose is very pure, having been deprived of the greater part of its carbon. It is, however, only a few sorts of small nails of this kind, such as tacks, that have stood the test of experience; the annealing process having the effect of not merely destroying the brittle quality, but of rendering the metal nearly as soft as copper, and, consequently, not sufficiently stiff for the purposes designed. All attempts to combine in cast iron nails the properties of adequate stiffness free from brittleness, having failed, the manufacture of *cut* or *pressed* iron nails by machinery, from sheets of wrought iron, has been resorted to, and it has been attended with considerable success.

*Cut or pressed iron nails.*—Sheets of rolled iron, of the thickness of the intended nails, are cut into strips or ribands, that are in width equal to the length of the intended nails; being then held horizontally, with a flat side upwards, the ends are pushed in a slide against a regulated stop, under a cutter, fixed to a powerful lever, or, as is generally the case, to the lower extremity of a fly-press, which cuts off a portion constituting a brad, or nail. In making brads or sprigs, which have no heads, and are merely wedge-formed pins, the strip of iron is turned upside down, alternately, at every cut, which keeps the inclination of the angle of the cut uniform throughout the length of the strip of iron without any waste. In making brads with half-heads, or bills, the strip of iron is kept with the same side upwards, and the position of the cutter is alternately reversed by making a half turn backwards and forwards; thus are formed two *billed-brads* out of one parallelogram. To make this matter understood, we add the annexed illustration:—



the strip *a* be turned upside down, and pushed against the stop *c*, the next portion *f* will take the place and position of *e*, and, consequently, be cut off by the next descent of the cutter *d d*; and thus, by repeatedly turning the strip over and back again, and pushing it forward every time with one hand, while the other is occupied in working the lever of a fly-press, the brads are formed with great rapidity. It will be seen, likewise, on reference to those lines marked *g* in the figure, that they represent two brads, with half-heads, or bills, which, being placed in that manner, head to point, it is obvious that, by turning the cutter half-way round alternately, they will be cut both alike, out of one parallelogram, as represented. Except for making the larger kind of cut nails, the strength of boys and women is fully competent, who are, consequently, employed in most manufactories, each of them working a distinct press; and headless nails are thus made by each worker with nearly the rapidity and regularity of the ticking of a watch. Ingenuity has, however, devised much more expeditious modes of working, of which the machine we shall next describe is a respectable specimen. It is a recent invention of Messrs. Ledsam and Jones,

of Birmingham, to whose enrolled specification of their patent we stand indebted for the following information.

Messrs. Ledsam and Jones have given, in their specification, a series of drawings, representing two different forms of their machine, together with several variations in the detail; but it has been our study to comprise all that is essential in the following elevation of their apparatus, which, we trust, will be comprehended by this explanation:—*a a* in the following engraving,

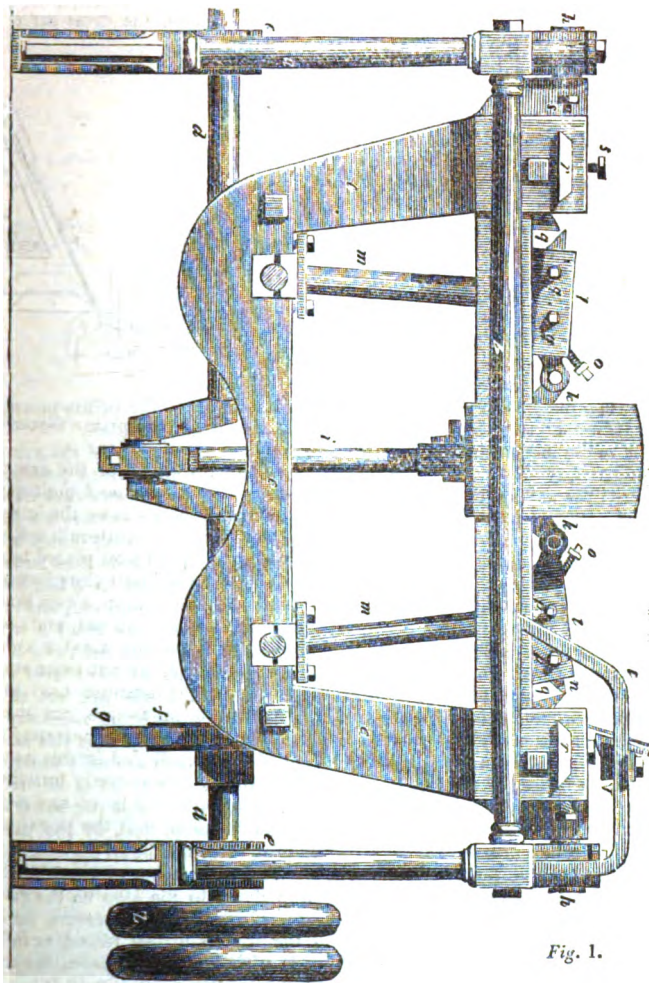


Fig. 1.

connect two (out of four) of the standards to the frame, the other two being behind them, and connected, in a similar way, by horizontal bars, as that at *k*. This frame is fixed, and forms the support of a swinging-frame *cc*, and a horizontal shaft *dd*, which revolves in bearings at *ee*; *f* is an eccentric on the shaft *d*, regulated by a screw, and acting on a frame *g*, attached to the swinging-frame *e*, which latter vibrates upon arms or trunnions *hh*; *i* is a connecting rod attached to the crank on the axis *d*, and to the axis of a stout pair



of leaves  $kk$ ; this axis moves vertically in a groove, as shown by dotted lines in the central cheeks of the swinging-frame; the leaves  $kk$  are connected by hinges to the boxes  $ll$ , which are supported by the rocking standards  $mm$ ; these boxes contain the *moving* cutters  $nn$ , which are kept in their places by screws (not shown); on the inclined faces of this gauge, the rods, or strips, of which the nails or brads are formed, rest;  $rr$  are fixed cutters in the end cheeks of a swinging-frame, and retained in their places by screws  $ss$ ;  $t$  a frame attached to the fixed frame, and carrying the cross-bar  $v$ , shown on a larger scale by the annexed *Fig. 2*;  $w$  is one of the guide rods hooked on the cross-bar  $v$ , and screwed up to a beam above;

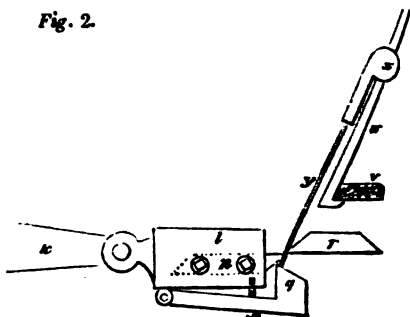
$x$  a perforated weight sliding upon  $w$ , having its lower end hollowed to receive the ends of the bar, or strip  $y$ , of which the brads are made. This bar slides down after every cut against the edge of the fixed cutter  $r$ , and rests upon the surface of the gauge  $g$ , which determines the breadth of the nail; then the leaf  $k$  forces forward the box  $l$ , containing the cutter  $n$ , which cuts off the iron in a right line with the plane of the under surface of the opposite cutter  $r$ .

*Fig. 1*, is a band-wheel for communicating motion from the prime mover, with a loose pulley at its side for throwing the machine out of action.

*The action of the machine is as follows*:—By the revolution of the axis  $d$ , the eccentric upon it forces the swinging-frame  $c$  into an *inclined* position; the crank on the axis at the same time acting upon the rod  $i$ , draws the leaves  $kk$  into a horizontal position, and thereby forces the movable cutters  $nn$  forward against the fixed cutters  $rr$ , dividing obliquely the strips of iron placed between them in their progress, the same as if cut by shears; the brads thus formed fall down the inclined surface of the gauge, and are received in a box beneath. The opposite vibration of the swinging-frame makes a second cut, and thus on both sides of the machine (though represented only on one side) a series of rods, or strips of iron, are placed in a line, all of which are cut twice at every revolution; thus, supposing eight rods or strips (the number used by the patentees) are applied to each pair of cutters, 32 brads are cut at every revolution of the axis: of course a considerable power being necessary to do this, that of a steam-engine, or water-wheel, is to be employed in this machine, in preference to manual labour. The ends of the cutters are only brought into view in the figure; these are, however, of greater, and may be of any required length, to cut a given number of brads at a time, as may suit the power of the engine, and other circumstances. It will now be seen, that, by the patentees employing long continuous cutters, and causing them to take an opposite inclined position at each vibration of the swinging-frame, a number of brads are cut at once, without moving the rods, which drop down to the stop on the gauge as they are cut. By the former mode described, with the fly-presses, the cutter moves always in the same plane, and the iron is turned round, or inclined, instead. In cutting that species of brads with heads, the patentees employ cutters with gaps left in their edges, and the cross-bar  $v$  has slits in it to receive the rods  $y$ , and, instead of being fixed, receives an alternating side motion from the frame.

For the purpose of *heading* the nails, the shanks made, as already described, are usually brought under the operation of a heavy hammer head, which is lifted from its work by a spring pole, like a turner's throw, and is brought down upon it by a pedal, worked by a woman, sitting down before a little bench; in front of this bench is fixed a pair of clams, which are opened and shut by the turn-

*Fig. 2*



ing of the lever of a screw on the left hand of the operator, who, with her right hand, successively places the shanks between the jaws of the clams, brings the hammer smartly down upon it, which forms the head; and then, by turning the screw with her left hand, the jaws open, and the newly-headed nail drops into a box underneath. The clams are provided with steel dies, impressed with the shape of the under-side of the head and that of the shank, and so much of the length only, as to leave projecting above the top a sufficiency of metal to form the head; the form of the upper surface of the head being determined by a die fixed in the face of the hammer.

There are, however, several manufactories in which the machinery is so constructed as to cut and head the nails by a single operation of the same machine. This mode of manufacturing, we believe, originated in America, where such machinery has been long since in successful use. In 1829 Mr. Edward Hancorne took out a patent for an improvement upon the American mechanism. We have perused the specification of this patent, from which we learn that the invention is "the communication of a foreigner residing abroad;" and that it consists in a machine made of two horizontal frames, the one movable and the other fixed, an axis with a crank, a cam, a fly-wheel, and drum. The bearings of the axis are attached to the lower or fixed frame, and the crank is connected with, and causes the upper or movable frame to traverse in grooved guides on the lower. From an iron rod, of an appropriate size, placed hot into the machine, a piece the size required for a nail is cut off by two cutting edges brought together by the motion of the upper frame, and held between two steels, while the head of the nail is formed by the action of a kind of hammer, whose face is shaped like a die into the form required, and whose stem is acted upon by a kind of cone on the axis. The nail is then to be tapered or pointed by the action of two eccentric steel sectors, whose circular surfaces are placed, at the commencement of the operation, sufficiently apart to receive the thickest portion of the nail; and at the termination of the operation, when they are brought by the motion of the upper frame in a position with the point of contact, is nearly in a line between the centres of motion.

*Brass and copper nails* are extensively used for shipping, and some other purposes. For nailing on the copper sheathing of ships, nails cast of an alloy of tin and copper are generally used; but great efforts were made by a manufacturer at Bristol, some years ago, to substitute for them nails of pure copper: these, for a time, obtained a preference in the navy yards, as well as the merchants' yards; it having been shown that the bottoms of ships, whose sheathing had been nailed with the rough-headed cast metal nails, were extremely foul, and that to the head of almost every such nail was appended a barnacle, which materially impeded the sailing of the ships. Mr. Guppy (the manufacturer to whom we have alluded) made his nails with a smooth bright head (produced by the polished surface of the hammer,) which, being counter-sunk underneath, were driven down flush with the surface of the copper sheathing. The improvement was evident, and experience showed that ships so sheathed sailed better and returned home from their voyages earlier, and with cleaner bottoms. This triumph, or rather success, was of short duration. Mr. Greenfell, who had for many years supplied the government with copper sheathing and nails, took the hint afforded by the smooth-headed nails, (the admirable construction of which were in other respects the subject of a patent granted to Mr. Guppy,) and had the rough heads of his cast nails made flat, smooth, and bright, on the upper surface, by turning in a simple kind of lathe; and upon repeated trials of these, they were found in no respect inferior to Mr. Guppy's patent, while they were materially cheaper, and they have, in consequence, maintained their ground, to the almost total exclusion of the pure copper nails, for the peculiar purpose mentioned. Pure copper nails are, however, extensively used in ship-building, and sea-going boats, on account of their greater durability than iron, when exposed to the action of salt water. The principal kind in use are *rose-clench*, similar in form to the iron nails of that denomination, already explained and figured. The manner of making these nails is similar to that of the other kinds, and may be readily explained and practised by our brief description. The

copper nail-maker furnishes himself from the copper wire-drawer with *square wire* of the sizes of the intended nails. Suppose, for instance, he has to make some rose-clench, two inches long; he takes the square copper wire of the required thickness of the nail, and, by means of his fixed shears, he cuts the wire into lengths of about 2 inches and  $\frac{3}{16}$ ; the  $\frac{3}{16}$  being required to form the head. They are all cut exactly of a length, by the wire being pushed against a stop before it is cut; this stop is fixed to the block, and is adjustable to any required distance from the edge of the shears. The only tools necessary to complete these pieces of wire into nails, are a strong smith's vice, a hammer, and a pair of clams, designed to hold wire of the size. The jaws of these clams open by a spring, and are closed by compressing the jaws of the vice; when so closed they leave a cavity between them, which is occupied by a piece of the copper wire before mentioned,  $\frac{1}{4}$  of which project above the upper surface of the clams. The workman then, with one or two blows of his hammer, drives the wire firmly to the bottom of the groove made between the clams (or against a stop placed therein); this has the effect of spreading out the head sufficiently to receive four more blows struck around it in an inclined direction, which produces four facets, meeting at the top, called a *rose-head*: then, by turning the handle of the vice, the jaws of the clams open, the nail is taken out, and another piece of wire substituted to repeat the heading operation described. It is obvious, that by the same tools, and a different application of the hammer, a flat, a diamond, or other formed head, may be made. To strengthen the heads underneath the upper edges of the clams are slightly countersunk; and in order that a single pair of clams may do for *various lengths* of one sized wire, the groove is made the depth of the longest; and for any nail of a shorter length, a piece of wire is dropped in the groove, as a *stop*, of such a length as, with the intended nail, to fill the groove entirely. Should the nails thus made be required with flat points, they are flattened by a few blows upon an anvil, in the cold state. Copper in the cold state is worked under the hammer with about the same facility as iron at a cherry-red heat.

**NAPHTHA**, or **ROCK OIL**, is a yellow or brownish bituminous fluid, of strong penetrating odour, greasy to the touch, and so light as to float on alcohol. By exposure to the air it thickens into the substance called petroleum. There are copious springs of naphtha at Baku, on the shore of the Caspian Sea. There are also at Pitchford, in Shropshire, extensive beds of sandstone, saturated with this fluid, which is separated from the stone by distillation, and is sold under the name of *Betton's British oil*. The Russians and Persians use naphtha internally, as a cordial. Naphtha burns with a brilliant white flame, and is therefore much used in lamps, both at home and abroad.

**NAPIER'S BONES**, or **NAPIER'S RODS**, are certain instruments invented by Lord Napier, for performing some of the fundamental rules of arithmetic, by an easy mechanical process. They may be made of bone, ivory, horn, wood, pasteboard, or any other convenient material. There are five of them, and the face of each is divided into nine equal parts, each being subdivided by a diagonal line into two triangles. In these compartments or squares the numbers of the multiplication table are inserted, the units or right-hand figures being placed in the right-hand triangle, and the tens in the left.

**NAPLES YELLOW**, is prepared by calcining lead with antimony and potash, in a reverberatory furnace. See **PAINTING**.

**NATRON**. The native carbonate of soda. It is found in vast abundance in the lakes near Alexandria, in Egypt.

**NAUTICAL INDICATOR**. For finding the latitude, longitude, and variation, invented by James Hunter, member of the Glasgow Philosophical Society. The indicator consists of a stand, supporting a circular plate of polished brass, about 14 inches in diameter, representing the horizon, and marked and numbered accordingly with the proper divisions. This horizon is surmounted by a semicircular plate, as a meridian, set at right angles to the plane of the horizontal plate, properly divided, and furnished with an index attached to a nonius, indicating minutes. This meridian plate is cut out at the centre to allow room for a pivot, or hinge, for other parts of the indicator. On one side of this meridian

are placed two quadrants, and on the other side one, similarly divided as the meridian, and furnished with a similar index and nonius. These quadrants are movable on a pivot or hinge, rising perpendicularly from the centre of the horizontal plate, or agreeing to this centre; they are singly movable on the pivot, but capable of being attached at any relative distance, and retained in that situation by a screw, binding together tails attached for that purpose. To the east and west points of the horizontal plate is attached a horary circle, divided into hours, &c. This horary circle represents the daily path of the sun, and it may be furnished with a nonius, as other parts are. This circle is so attached to the horizontal plate, that it can be moved parallel to it to suit the sun's declination; this is effected by the circle being attached to two tangent plates, which, by grooves, slide on the projections from the horizontal plate by means of screws passing through and working in these projections, and carrying the tangent plates, and with them the horary circle, to the degree of the sun's declination. This degree is indicated on a scale of tangent divisions on the tangent plates; and as such tangents are of various lengths, an expanding vernier is used to adjust them. Its expansion is effected by friction wheels, and springs working against a proper curve.

**NAVE.** The central boss, or *hub*, as it is in some places called, of a wheel, through which the axletree passes, and which receives the ends of the spokes in deep mortices made therein. Although the naves made of wood are usually of great solidity, these parts are so subject to strains and concussions as not to be so durable as the mass of material might lead one to suppose. In consequence of this defect, a patent was taken out some years ago for making this part of cast iron, which has been extensively, and, we doubt not, advantageously adopted.

**NEEDLES.** Well known little instruments, usually made of steel, pointed at one end, and perforated at the other, to receive a thread, for sewing with, &c. The processes of manufacturing needles have been much varied, but the following account combines the most recent improvements.

Steel wire of the size required, after having been annealed, is cut from the coils into lengths of four or five inches; these are gathered up into cylindrical bundles of three or four inches in diameter, over the ends of which are passed two stout iron rings, and more wires in their curved state are forced amongst those in the bundle, until the rings are tightly packed. This bundle is laid upon an iron slab, and over it a bar of iron about two feet long is placed, transversely between the two iron rings; the workman then takes hold of each end of the iron bar, and, pressing it against the bundle of wires, he rolls the latter backwards and forwards over the iron slab until every steel wire in the bundle becomes perfectly straightened. These wires are next pointed upon a grindstone running dry. In this operation, the workman, sitting astride before the stone on a block shaped like a saddle, takes up 20 or 30 wires, laid side by side across a small wooden ruler, covered with soft leather, another similar ruler being laid over the needles to confine them. The workman holds the rulers in his hands, and thus presenting the wires to the grindstone, points them with great dexterity, each wire revolving whilst in contact with the stone. After pointing, the wires are cut off the length of the required needles. The next operation is flattening a little the ends that have to receive the eyes. This is effected by a workman taking three or four pieces of wire between his finger and thumb, placing them upon an anvil, and, striking one blow upon each, expands the ends sufficiently to receive the point of the punch, which pierces the eye. This the same person does, before he lays them down, with a small instrument, fixed on the same block as that to which the handle is fixed. The end of the needle is placed in a small notch in the bed of the instrument, and is put exactly beneath the punch, and a slight stroke of the hammer punches the eye, and at the same time forms the semicircular groove near the eye of the needle, to bury the thread. The notch which receives the needle is made in a piece of steel, which fits into a dove-tailed notch in the bed of the instrument, so that it can be changed for a larger or smaller, correspondent to the size of the needles to be pierced. The workman holds the needles in the same manner

as he did for flattening; and placing them one by one successively in the notch in the bed-piece, pierces them through by a single blow of his hammer in the end of a slider, which recoils to its former position by the reaction of a spring. He now places the next needle under the punch; and when they are all pierced in this manner, he rolls them over by moving his thumb, so as to turn them all half-round, and bring them upwards on the opposite side to that which was pierced; this being done, he repeats the punching on the other side with a view to finish and clear the eye, and to complete the groove which there is in all needles. They are now rounded at the eye end to take off the roughness, which is effected in an instant by applying them to a grindstone.

In making the larger kinds of needles, the grooves are formed, and the eyes pierced, by a stamp and fly-press. A piece of wire of the length of two needles, and pointed at both ends, is placed exactly in the middle, upon a steel die, having the form of the eye groove, &c. projecting from its surface; and over this die is suspended another exactly similar, so that, by means of a blow from the stamp hammer, the two needles between the dies are exactly impressed on both sides with the grooves already mentioned. The piece of pointed wire is then in a similar manner placed under a fly-press, where, by means of two very delicate steel punches falling over corresponding holes in a die, the two eyes are instantly pierced with great precision. These needles are then divided, and the heads corrected with a smooth file. During these operations the needles have become more or less crooked; these are, therefore, placed in files on a smooth metal plate, and with an iron rolled until they are straight.

The next processes are hardening and tempering. To effect these, the needles are placed several thousands together, covered with ashes, in a cast-iron box, and heated in a close furnace to a cherry red, when the box is withdrawn, and its contents dropped into a tub of cold water; they are next taken out of the water, and placed upon an iron plate, kept nearly red hot by means of a fire underneath; here they are carefully distributed about, so as to heat them equally, and until they acquire the blue tinge, when they are immediately removed. Some manufacturers make use of oil or tallow, and other ingredients, instead of water, which substances are supposed by them to improve the process. The needles, thus hardened, are returned to the furnace with the oil upon them, and remain there till the oil inflames, when they are withdrawn and again cooled in cold water. This second process tempers them; at first they were quite hard, and so brittle as to break with the slightest touch; the tempering renders them tough, yet sufficiently hard to take a good point. When they are hardened in water, according to the former method, it is considered that the proper heat for tempering them can only be determined by long experience and observation; but that the flaming of the oil determines the precise temperature. If the needles be now examined, many of them will be found to have become crooked in the hardening; these are discovered by rolling them over as they lay in rows on a board, and such are selected and made straight by a blow in a notch in a small anvil for the purpose. In some manufactories the needles are next pointed and finished; in others, where the pointing has been already effected, the next process is that called—

*Scouring.*—In this process the needles are piled in rows many tiers deep, and in several parallel rows, upon a piece of buckram, or stout cloth, which is saturated with oil and fine emery. The needles, after they are deposited, are also sprinkled over with flour of emery and oil, when the whole mass, containing from 10 to 50,000 needles, is tightly rolled up and well bound at both ends. Several of such rolls are operated upon together by a kind of mangle; a stout plank being laid upon the rolls of needles, which is loaded with heavy weights, and made to traverse backwards and forwards for two or three days. During this time several successive wrappers have been completely worn out, which have been replaced by new ones, with fresh charges of oil and emery, and sometimes soft soap. At the end of three days they are thus made very bright and clean.

In the next operation, called heading and picking, the eyes of all the needles are placed in one direction, and all the points in another; and all the needles

with broken eyes or points, are picked. These operations are usually performed by children with a dexterity and rapidity that can only be acquired by practice. The needles are placed sideways in a heap, on a table in front of the operator. The child puts on the forefinger of its right hand a small cloth cap, or finger-stall, and rolling from the heap from six to twelve needles, it keeps them down by the forefinger of the left hand, whilst it presses the forefinger of the right hand gently against the ends of the needles; those which have their points towards the right hand, stick into the finger-stall; and the child, removing the finger of the left hand, allows the needles sticking into the cloth to be slightly raised, and then pushes them towards the left side. Those needles which had their eyes on the right hand, do not stick into the finger-stall, and are pushed to the heap on the right side previous to the repetition of the process; each movement of the finger carrying five or six needles to its proper heap.

The finishing operation to the best needles consists in what is termed blue pointing, in allusion to the dark polish upon them; this is effected by a revolving stone, of a bluish colour, against which the needles, several at a time, are applied. After this they are made up into little packages of from 25 to 100 each, and labelled for sale.

The needles which have, of late years, been so much puffed by the vendors as "warranted not to cut the thread" and to be "gold-eyed" and "silver-eyed," are made the same as other needles with these trifling variations;—the eyes of the former being produced by dipping them into an ethereal solution of gold; but the eyes of the latter have not a particle of silver laid over them, the silvery hue upon them being produced by a peculiar kind of polish. The "drilled-eyed needles" do, however, possess the merit of being less disposed to cut the thread; the eyes of these are made, at first, in the usual way, and are afterwards finished by a drilling counter-sink, which improves them materially; and the steel being softened to enable the drill to cut, they rarely snap or break in the eye.

*Packing-needles, bodkins, &c.*—Some years ago a patent was taken out for making needles of this kind, by Mr. William Bell, of Walsall; and as the manufacture of them has ever since been continued with success, we shall close the present subject by subjoining that gentleman's brief specification verbatim. "The method by which I make needles, bodkins, fish-hooks, knitting-pins, netting-needles, and sail-needles, is by casting them with steel, or common fine iron, called pig or cast-iron, into moulds, or flasks, made with fine sand; or, otherwise, I make stocks or moulds, of iron or steel, or any other composition capable of being made into moulds; on which stocks or moulds I sink, engrave, or stamp, impressions of the said articles. Into these I pour my melted iron or steel (I prefer for my purpose sand casting), and prepare my iron or steel as follows:—I melt it in a pot, or crucible, in small quantities about the weight of twelve pounds (and upwards to twenty pounds), the more conveniently to divest it of its heterogenous particles, and to purify it from its earthy or sulphureous qualities. When the iron has attained a proper heat, I take charcoal-dust, mixed with lime or common salt, which I throw into the pot of melted iron; and, by frequently stirring it with an iron rod, I bring to the surface of the iron a scoria, which I frequently skim off, and thus bring my iron into a refined state; I then pour it into the mould before described. The articles being thus formed, are capable of being softened, hardened, or tempered, in the usual way, by which needles, bodkins, fish-hooks, knitting-pins, netting-needles, and sail-needles, have, heretofore, been manufactured; therefore, the principal merit of my invention is in casting them instead of making them in the usual way."

**NET.** A trellis-like fabric of threads or cords, chiefly used for entrapping fish, birds, and other animals. The term is likewise applied to a particular branch of manufacture, of a fine open texture, usually applied to the purposes of dress. The making of the former description of net is an easy process. The necessary tools merely consist of wooden needles, of different sizes, some round, and others flat, a pair of round-pointed and flat scissors, and a wheel to wind off the threads; the strength of the packthread, of which the net is composed

and the size of the meshes, depending upon the particular description of birds or fishes required to be taken. It is necessary, in many cases, to alter the natural colour of the thread; the colour usually used is russet, which is obtained by immersing the thread in a tanner's pit, and letting it lie there until sufficiently tinged. A green colour, which is sometimes desirable, is obtained by chopping some wheat, and boiling it in water, and then soaking the net in the tincture. A yellow colour is obtained by the same process, using the decoction of celandine, which gives a pale straw colour.

Mr. Alexander Buchanan, of Paisley, some years ago invented an ingenious machine for weaving any description of net-work without knots, and likewise to allow the holes or meshes of the net-work to be enlarged or diminished at the pleasure of the operator. The annexed engraving will convey an adequate idea of this machine. A B C D represents a wooden stand, upon which an iron

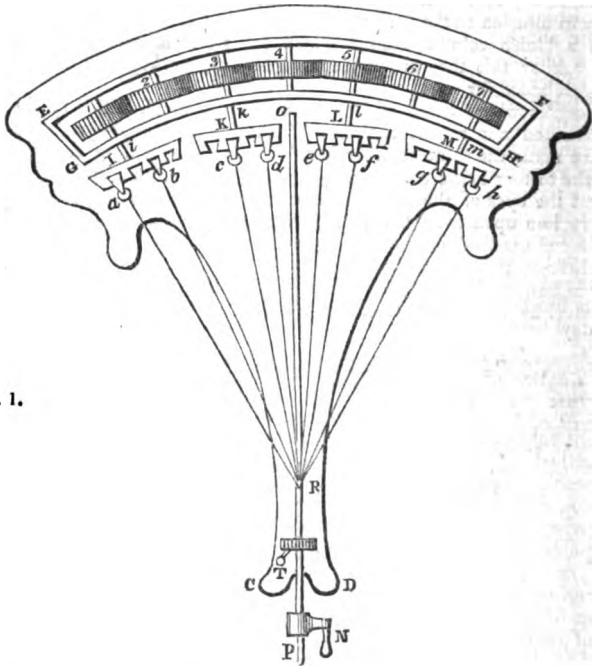
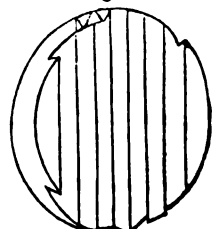


Fig. 1.

frame EFGH is supported at each corner; in this frame there are seven wheels 1 2 3 4 5 6 7 that pitch into each other; *iklm* are continuations of the axis of the wheels numbered 1 3 5 7; upon the ends of the axis thus continued, circular pieces of wood I K L M are fixed, of which Fig. 2 is a representation. The other wheels 2 4 6 are introduced in order that, when the machine is put in motion, those numbered 1 3 5 7 may revolve in the same direction, as it is necessary that the parts of the machine attached to the axis of these should do so. Into each of the circular pieces of wood four grooves are cut, which allow the shuttles *abcdefghijkl* to slide out and in, at the circumferences of the circular woods, but prevent them from coming out when drawn in a direction towards R; the use of the grooves is to allow the shuttles to be moved from one circular wood to another in crossing the threads to form meshes of the net-work. In our figure the circular

Fig. 2.



woods are represented as turned half round, to show the grooves and shuttles in them. The pirns, or bobbins, of which one end is considerably thicker than the other, are provided with grooves, which, when the bobbin is placed in its proper position, admits a spring, which acts as a counterpart to a weight suspended from the ends of the threads; each of these springs must be individually so strong that their aggregate strength will prevent the weight from drawing the threads off the pirns, and, at the same time, sufficiently weak to allow the threads to come easily off the pirns when drawn by the operator. Into the centre wheel: 4 another pitches, having the same number of teeth; this wheel, which cannot be represented in the figure, is fixed to one end of the iron rod O P, at the other end of which a handle N is attached; by this handle the machine is put in motion.

Having now given a general description of Mr. Buchanan's machine, we proceed to the method of using it. The pirns or bobbins having been previously filled with thread, or with any other material of which the net-work is to be composed, are placed on the shuttles. The ends of the threads are then collected and tied together; after which they are put through a ring that is fastened on the top of the gudgeon S, and also through a hole T in the sole, or wooden stand; a weight is then suspended by the threads, the use of which is to prevent them from entangling. It must be observed, however, that before the machine is put in motion, the shuttles occupy the proper grooves; this is illustrated in Fig. 1, where the shuttles *a b*, in the circular wood I, occupy the first and third grooves; those of K occupy the second and fourth; those of L the first and third; and those of M the second and fourth. The operator then commences weaving the net-work by turning the handle at N; the size of the meshes of the net-work he increases or diminishes at pleasure, by turning the handle a greater or less number of times. The wheels are thus made to revolve in the iron frame, the circular pieces of wood likewise revolving in consequence of the continuation of the axis of four of the wheels, by means of which the threads that proceed from the shuttles of each, are twining round each other. The twist made by this movement is made fast by the operator, who puts a finger of his left hand between each pair of threads, and with his right hand inserts horizontally the clearer, which is a thin piece of wood, shaped like a paper cutter, between each pair of threads, drawing both his hand and the clearer towards R, at which place it is prevented going any farther by a knot. He then removes his hand, leaving the clearer to keep the twist tight, and crosses the threads to form the meshes. This is effected by moving the shuttles from one circular wood to another, which operation resembles and effects exactly the same object as the crossing of the pins in working lace; the shuttles of the middle circular woods are changed first. Those of the circular wood K, occupying the second and fourth grooves, are moved into the second and fourth grooves of the circular wood L, while those of L are shifted into the first and third grooves of K; this movement forms half a mesh. The operator then turns the handle the same number of times as formerly to twist the other side of the mesh that is already half-formed. This being done, and the twist made tight by the method just explained, the threads are again crossed, which is effected by moving the shuttles. By the first moving of the shuttles, those of the circular woods K were shifted into the corresponding grooves of L, and *vice versa*; so that by shifting them in the present instance, those which originally occupied L are moved into I, and those that originally occupied K into M; this operation completes other two meshes: thus, by twining and crossing the threads, any quantity of net-work may be wove, the operator drawing more thread off the pirns as the former quantity is used.

**NICKEL.** : A white metal, which, when pure, is both ductile and malleable, and may be forged into very thin plates, whose colour is intermediate, between that of silver and tin, and is not altered by the air; it is nearly as hard as iron. Its specific gravity is 8.279, and, when forged, 8.666. The species of nickel ores are its alloy with arsenic and a little sulphur, and its oxide. The first is the most abundant, and the one from which nickel is usually extracted. It is known as *Mineralogists* by the German name of *kupfernickel*, or false copper, from its



colour and appearance ; it occurs generally massive and disseminated ; its colour is copper red, of various shades. By the experiments that have been made, nickel, in its pure state, possesses a magnetic power. The effect of the magnet on it is little inferior to that which it exerts on iron ; and the metal itself becomes magnetic by friction with a magnet, or even by beating with a hammer. Magnetic needles have been made of it in France, and have been preferred to those of steel, as resisting better the action of the air. The nickel preserves its magnetic property when alloyed with copper, though it is somewhat diminished ; by a small portion of arsenic it is completely destroyed. Nickel is fusible at 150° of Wedgwood, and forms alloy with a number of metals. Nickel is found in Cornwall, and in some other counties of England ; in Germany, Sweden, France, Spain, and several parts of Asia. The Chinese employ it in making white copper ; and, in conjunction with copper and zinc, they manufacture it into various kinds of children's toys. Nickel gives a certain degree of whiteness to iron ; it is used with advantage by some of the Birmingham manufacturers, in combination with that metal ; and, by others, in combination with brass. If it were possible to discover an easy method of working nickel, there can be little doubt but it would be found very valuable for surgical instruments, compass needles, and other articles, since it is not, like iron, liable to rust. Oxide of nickel is used for giving colours to enamels and porcelain : in different mixtures it produces brown, red, and grass-green tints.

**NITRATES.** Compounds of the nitric acid, with various salifiable bases.

**NITRE.** The usual name given to a combination of the nitric acid with potash. See **ACID, NITRIC.**

**NITROGEN.** A simple or undecomposed gaseous substance, was first distinguished by Dr. Rutherford, in 1772. It is sometimes called azote, from its inability to support animal life ; but it is commonly designated nitrogen, from its being an essential ingredient in nitric acid. It constitutes four-fifths of the volume of the atmosphere, and may therefore be procured by abstracting the oxygen from atmospheric air. It may be conveniently prepared by burning a piece of phosphorus in a jar full of air, inverted over water. The phosphorus, on account of its strong affinity for oxygen, will abstract it from the mixture, and the vessel will become filled with a white cloud, which is the pyrophosphoric acid. In about half an hour this will subside, and the residual gas is nitrogen, contaminated with a little carbonic acid and vapour of phosphorus, both of which may be removed by agitating them with a solution of pure potash. A solution of protosulphate of iron, charged with binoxide of nitrogen, will separate the oxygen from common air in a few minutes. A stick of phosphorus placed in it will accomplish the same in twenty-four hours. Nitrogen gas may also be obtained by exposing a mixture of fresh muscle and nitric acid to a moderate temperature. Effervescence occurs, and a large quantity of nitrogen, mingled with carbonic acid, is evolved, the latter of which may be removed by agitation with lime water. Nitrogen, when pure, is a colourless gas, devoid of either smell or taste ; it does not burn, and extinguishes all burning bodies immersed in it ; it does not change the blue colour of vegetables ; no animal can live in it, yet it exerts no injurious influence on the lungs or other parts of the animal system, the privation of oxygen being the sole cause of death. Water, when deprived of air by boiling, takes up about one and a half per cent. of it. Its specific gravity is .9722 ; and therefore 100 cubic inches, at a mean temperature and pressure, will weigh 30.15 grains. In the combination of nitrogen with oxygen in the atmosphere, it seems merely to moderate or dilute the oxygen, so as to render its action less energetic. Considerable doubts have existed as to its simple nature, in consequence of experiments made with the galvanic battery. When ammonia (which is a compound of nitrogen and hydrogen) is submitted, in conjunction with mercury, to the action of galvanism, an amalgam is formed, which is considered to arise from some metallic base in the hydrogen or nitrogen ; but as the idea of a metallic base to hydrogen seems precluded by reason of its extreme lightness, it has been inferred that it must form a constituent of the nitrogen. This supposition, however, seems incapable

of proof, as the constituents of the amalgam separate, and are resolved into ammonia, hydrogen, and mercury, as soon as the galvanic influence is withdrawn. Nitrogen unites with several substances in different proportions, forming a variety of compounds, distinguished by striking peculiarities. With oxygen are formed the nitrous and nitric oxide, and the hypo-nitrous, nitrous, and nitric acid. With chlorine and iodine it forms the chloride and iodide of nitrogen, and with hydrogen it forms ammonia. Our limits will permit us to give but a brief account of these. The nitrous oxide, or protoxide of nitrogen, was discovered by Dr. Priestley in 1772, who called it dephlogisticated nitrous air. The best mode of procuring it is by means of nitrate of ammonia. When this salt is exposed to a temperature of 400° or 500° Fahr. it liquefies, and bubbles of gas begin to escape, and in a short time a brisk effervescence ensues, which continues till all the salt disappears. The nitrate of ammonia should be contained in a glass retort, and the heat of a lamp applied, so as to maintain a moderately rapid evolution of gas. In accurate experiments the gas must be received over mercury; but for ordinary purposes it may be received over water. It has a sweet taste, and a faint, agreeable odour, and is absorbed by its own volume of recently-boiled water. Most substances burn in it with far greater energy than in the atmosphere; but the most remarkable of its properties is its effect when respired. A few deep inspirations are followed by the most agreeable feelings of excitement, similar to the early stages of intoxication. This is shewn by a strong propensity to laughter, by a rapid flow of vivid ideas, and an unusual disposition to muscular exertion. These feelings soon, however, subside, and the person recovers his ordinary state without experiencing that languor which is the usual result of excitement by spirituous liquors. It varies somewhat in its effects on different individuals, and sometimes produces disagreeable symptoms. The specific gravity of this gas is 1.5277; and 100 cubic inches weigh 47.377 grains. The binoxide of nitrogen, or nitric oxide, is best obtained by the action of nitric acid of specific gravity 1.2 on metallic copper. Brisk effervescence ensues, and the gas may be collected over water or mercury. The nitric oxide is a colourless gas; but when mixed with oxygen or atmospheric air, dense suffocating, orange-coloured vapour of nitrous acid is produced. Few inflammable substances burn in it; charcoal and phosphorous, however, when in vivid combustion, burn in it with increased brilliancy. It is sparingly absorbed by water, does not redden vegetable blues, and is quite irrespirable. 100 cubic inches weigh 32.3 grains, and its specific gravity is 1.0416. The hypo-nitrous acid has not hitherto been obtained in a free state, but combined with potash. Pure nitrous acid is formed by the mixture of binoxide of nitrogen with oxygen gas, out of contact with either water or mercury. When condensed in water, it forms the liquid nitrous acid.

**NORIA.** See **HYDRAULIC MACHINES.**

**NUTGALLS.** Excrescences formed on the leaves of the oak by the puncture of an insect, which deposits an egg upon them. The best galls of commerce are those imported from Aleppo; they are chiefly used by dyers, calico printers, and ink makers, and are peculiarly valuable on account of their richness in tannin and the gallic acid.

**NUTMEG.** The kernel of a large fruit, not unlike the produce of the miristica. The nutmeg is separated from its investient coat, the mace, before it appears in commerce.

## O.

**OAKUM.** The substance into which old ropes are reduced when they are untwisted, loosened, and drawn asunder. It is used chiefly for caulking the seams of ships.

**OAR.** A long piece of timber, flat at one end, and round or square at the other, used to propel a vessel through the water. The flat part, which is

dipped in the water, is called the blade; and that which is within the board is termed the loom, whose extremity, being small enough to be grasped by the rowers, is called the handle. To push the vessel forwards by this instrument, the rowers turn their backs forwards, and dipping the blade of the oar in the water, pull the handle forward, so that the blade at the same time may move aft in the water. But since the blade cannot be so moved without striking the water, this impulsion is the same as if the water were to strike the blade from the stern towards the head; the vessel is therefore necessarily moved according to the direction. Hence it follows that she will advance with the greater rapidity, by as much as the oar strikes the water more forcibly; consequently, an oar acts upon the side of a boat or vessel like a lever of the second class, whose fulcrum is the station upon which the oar rests on the boat's gunwale. In large vessels this station is usually called the row-port; but in lighters and boats, the row-lock. Oars for ships are generally cut out of fir-timber; those for barges, out of Dantzic or New England rafters; and those for boats, either out of English ash or Norway fir rafters. See Boat.

**OBSERVATORY.** A building purposely constructed for viewing the heavenly bodies, and furnished with suitable instruments and conveniences for facilitating the operations.

**OCHRE, (red,)** is an iron ore of blood-red colour, which is sometimes found in powder, and occasionally in a hardened state. It has an earthy texture, and sometimes stains the fingers when handled. The principal use of red chalk is for drawing. For the latter purpose, it should be free from grit, and not too hard. In order to free it from grit, and render it better for use, it is sometimes pounded, washed, mixed with gum, and cast into moulds of convenient shape and size. Under the name of red-lead, this substance is much used for the marking of sheep, and when mixed with oil, for the painting of pales, gates, and the wood-work of out-buildings.

**ODOMETER.** An instrument for measuring the distance travelled over by a post-chaise or other carriage; it is attached to the wheel, and shows, by means of an index and dial-plate, the distance gone over.

**OIL.** The distinctive characters of oil are unctuousity and inflammability, insolubility in water, and fluidity at moderate temperatures. Oils are distinguished into *fixed*, or *fat* oils, which do not rise in distillation, at the temperature of boiling water; and *volatile*, or *essential* oils, which do rise at that temperature with water, or under 320° by themselves. The latter having been treated of under the word **ESSENTIAL**, in the preceding part of this work, we shall here confine our attention to the former class chiefly.

*Fixed* oils are generally contained in the seeds and fruits of those vegetables of which they are the products, and are formed principally at the period of maturity. They are extracted by pressure, sometimes with, and sometimes without, the aid of heat. They are usually impregnated with the mucilaginous or extractive matter of the vegetable, whence they acquire colour, odour, and taste; and if heat has been employed to favour their extraction, they acquire acrimonious qualities, and undergo a change in some of their chemical properties. The purest oils are those expressed from the fruit of the olive, or the seeds of the almond; others less pure are extracted from linseed, hempseed, and numerous other seeds of plants. Fixed oils are usually fluid, but of a thick consistence, and they congeal at moderate temperatures; some are even naturally concrete. When fluid, they are transparent, colourless, or of a yellowish or greenish tinge, inodorous, and insipid; they are lighter than water. The following table exhibits the specific gravities of the principal sorts of commerce; water being 1.000:—

Cacao . . . . .	0.892	Almond . . . . .	0.939
Rape seed . . . . .	0.913	Linseed . . . . .	0.939
Olives . . . . .	0.913	Poppy . . . . .	0.939
Ben . . . . .	0.917	Hazel-nut . . . . .	0.941
Beech-nut . . . . .	0.923	Palm . . . . .	0.968
Walnut . . . . .	0.932		

Fixed oils are incapable of combining with water; and are very sparingly soluble in alcohol, in the cold, with the exception of castor, which is abundantly dissolved by rectified alcohol, and of linseed oil, which is dissolved, though more sparingly; boiling oil dissolves it, and also the others in sensible quality.

Expressed oils cannot be volatilized by heat, without a change of their properties. At temperatures below 600° of Fahr. they remain fixed, if the heat has not been for a long time continued. At the temperature mentioned, they are converted into vapour, but the oil condensed therefrom is altered in its properties; it has lost its mildness, and has become more limpid and volatile, a portion of carbon having been deposited. Transmitted through an ignited tube, oil is converted into carbonic acid, and carburetted hydrogen, with a small portion of acid liquor, and a residuum of charcoal. Exposed to a warm atmosphere, expressed oils gradually acquire a sharp taste and smell, and become thick. This change, termed rancidity, is owing to absorption of oxygen. Drying oils, as those expressed with the aid of heat are named, do not become rancid, but by absorbing oxygen, are partially converted into a resinous kind of matter. At the temperature of ignition, at which it is converted into vapour, oil burns in atmospheric air, a large quantity of light and heat being extricated by its combustion. When the access of the air to the vapour of the oil is insufficient, it burns with a black smoke, and a quantity of carbonaceous matter which has escaped the combustion is deposited. Hence the utility of a slender wick, which draws up the oil by capillary attraction, and when kindled, produces sufficient heat to convert it into vapour. In a hollow cylindrical wick, like that in the Argand lamp, through which an internal circulation of air is established, the supply of air is more abundant, and the whole of the oil is consumed; the illumination therefore is greater, though there is some diminution of it in consequence of the light from the internal surface having to pass through the flame. Expressed oils combine with the alkalies, and form soap, which see. Expressed oils dissolve phosphorus by the aid of heat, forming a liquid, which becomes luminous when exposed to the air. They combine with a number of the metallic oxides, and acquire thereby a drying property. Boiled with oxide of lead, expressed oil forms a compound of firm consistency, constituting the "common plaster" of the apothecaries. Expressed oils form the basis of paints (see PAINTING), and are hence called oil-colours, (see also, OIL-COLOUR CAKES, subjoined to this article.) Expressed oils, combined with resins and turpentine, form varnishes; (see VARNISH.) Combined with lamp-black, they form printing-ink; (see INK.) For most of these uses, however, the drying-oils are employed. There are two distinct processes of obtaining oil by pressure; one cold, the other warm; the cold-drawn oil being preferable for one purpose, and the warm for another. In the former, the substances are submitted to pressure, without increasing their natural temperature; in the latter, heat is artificially applied, generally through the medium of steam or air. The application of heat to seeds and most oleaginous matters, causes a great quantity of the oil to flow out, without pressure; and heat softens them so much, that less mechanical force becomes necessary to expel the remainder. It is therefore an indispensable point of economy to make use of heat whenever the application of it does not deteriorate the quality of the oil; for more oil is thus obtained with less labour. In the large manufactories, linseed and rape-seed are the chief vegetable substances from which oil is obtained, in this country; heat is usually employed before pressure, and the separate products of oil in the different stages of manufacture are preserved, as distinct qualities. The ordinary "mill" for this purpose consists usually of an extensive range of machinery, and is usually distinguished by the denomination of the Dutch Mill, as the industrious people of Holland were the inventors, or chief improvers of it. In these, the seeds are put into bags, and covered with envelopes, consisting of hair-cloth, and sheep-skin sewn together; in this state, they are subjected to pressure by the force of wedges, that are continually being struck by perpendicular stampers. These stampers are raised by cams fixed to a revolving axis, (worked by a steam-engine, or other adequate power,) and fall from the height they are thus raised upon the wedges. The oil thus expressed, runs off, and is conducted to a cistern,

and the seed in the bag is reduced to a very hard solid cake, which is sold for the feeding of cattle, as it retains a considerable portion of farinaceous and other nutritive matter. Of late years the elastic force of steam has been introduced to give the necessary pressure, and the patented improvements by Mr. John Hall, jun. (of Dartford), which we have now to describe, consist in the peculiar method by which this power is applied. *aa* (Fig. 1) are two elliptical iron cams, firmly fixed on the horizontal shafts of two cog wheels, which gear into one another; *BB bb*, are massive iron plates, between which the seed bags *cc*, in their envelopes, are placed; *d* is the steam cylinder; *e* the piston to the same, which, when raised by the force of the steam from underneath, elevates the beam *f*, and the connecting rods *gg*; these being attached to the levers *hh*, turn the cams so as to press against the plates *BB*; which pressure is continued until the cams arrive with their longest diameters in an horizontal direction, as shewn by Fig. 2. By these means the oil is squeezed out, and received into a proper receptacle underneath. On the other side of the steam cylinder, another apparatus, similar in all respects to that shewn, is fixed, and moved by the same power; but in these the longest diameters of the cams are placed in a reverse direction, or at right angles with those in the engraving; so that when the utmost pressure is excited on one side of the cylinder by the ascent or descent of the piston, no pressure whatever is given on the other, and the bags may be removed to be emptied, and replenished with a fresh quantity of seed. The employment of elliptical cams is altered with a very great convenience, which we ought not to omit noticing. The two innermost plates *BB* are connected together by means of straps, as shewn at *ii* (Fig. 2) stretched out while the cams are exerting their pressure; when that pressure is relieved by the cams being turned into the position of these in Fig. 1, the connecting straps *ii* are raised, and the two plates *BB* are drawn towards one another; the bags are then perfectly free to be removed by the workman, to be filled again and replaced; and so on alternately, on opposite sides, at every ascent or descent of the piston.

The steam pressure upon the piston, employed by the patentee, is from forty to fifty pounds upon the inch, nearly the whole of which, owing to the simplicity of the apparatus, is transferred to the end of the cams, where the power is increased according to the ratio of their surfaces, compared to that of the piston. A steam apparatus is constructed near to each pair of cams, for the convenience of heating the seeds, with means for discharging the cake and refilling the bags.

In the year 1828, the Society of Arts presented Mr. Cogan with their silver medal, for the communication of a process for purifying rape and linseed oils. Mr. Cogan's process, though resembling M. Thenard's in the first part of it, is completed by the judicious introduction of steam; by means of which the oil appears to be almost entirely freed from acid, and the black feculent dregs subside in the course of twelve hours, leaving the upper portion of the oil quite clear, and greatly improved in colour, and in those qualities for which it is valued by the painter. The quantity of oil that he operates upon at once is about 100 gallons. For this, three quarts, that is about ten pounds, of sulphuric acid, oil of vitriol, is required. The acid is to be diluted with an equal bulk of

Fig. 1.

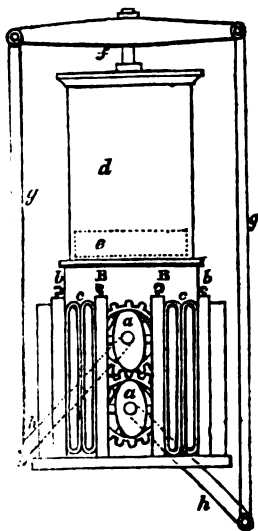
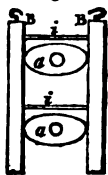


Fig. 2.



water. The oil being put into a copper pan, of the shape of a boiler, two quarts of the dilute acid are to be added; the whole is then to be stirred up very carefully for an hour or more, with a wooden scoop, till the acid is become completely incorporated with the oil, and the colour of this last has become much deeper than at first. A second similar quantity of acid is to be added, and mixed with the oil, the same as the first was; and after this the remaining third part of acid is to be added. The stirring of the oil is to continue incessantly about six hours in the whole, at the end of which time the colour of the mixture will be almost that of tar. It is then to be allowed to stand quiet for a night, and in the morning is to be transferred to the boiler; this is of copper, and has a steam pipe entering it at the bottom, and then dividing into three or four branches, each of which terminates in a perforated plate. The steam thus thrown in, passes in a very divided state into the oil, penetrates into every part of it, and heats it to the temperature of boiling water. The steaming process is to be continued for about six or seven hours, at the end of which time it is to be transferred to a cooler, of the form of an inverted cone, terminating in a short pipe, commanded by a stop-cock, and also having a stop-cock inserted in its side, a few inches from the bottom. After remaining a night in the cooler, the oil is fit to be withdrawn; for this purpose, the cock at bottom is opened, and the black watery acid liquor flows out. As soon as the oil begins to come, the cock is closed, and that in the side of the cooler is opened. From this the oil runs quite clear and limpid; the whole of that which is still turbid remaining below the upper cock. The purified oil being drawn off, that which is turbid is let out into a reservoir, where it either remains to clarify by subsidence, or is mixed with the next portion of raw oil.

The following is the patented process adopted by Mr. M. Wilks, seed crusher of Dartford, for purifying the oil from linseed, as well as other seeds, by expression. Into 236 gallons of the oil, six pounds of oil of vitriol is to be poured, and be well mixed by agitation or stirring about for three hours. Six pounds of fuller's earth is next to be mixed up and thoroughly incorporated with fourteen pounds of hot lime, and thrown into the vessel containing the oil and vitriol, when the whole is to be kept in agitation for about three hours more. The foregoing mixture is next to be turned into a boiler containing a quantity of water equal to that of the oil, and the whole is then to be boiled for another three hours, during which time the liquid is to be continually agitated by stirring. The fire may now be extinguished, and when the materials have become cool, the water may be drawn off, and the oil will be found clarified, which will become brighter and more fit for use after standing some time.

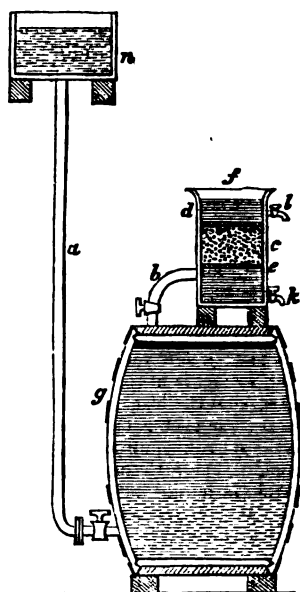
Mr. Robinson, of Edinburgh, having witnessed the difficulties and waste which take place in filtering and clearing oil from its dregs; in which operation, as it is usually conducted, a great deal of the advantage which is gained by repose and subsidence, is again lost in drawing off the oil to pass it through the filter, it appeared to him that by introducing water through a regulated aperture, and from a height sufficient to give the requisite hydrostatic pressure into the bottom of the butt of oil, and making a communication from the top of a butt, to a filter acting by ascension, all the advantages arising from refuse and subsidence would be retained, and by adapting the nature of the filter to the quality of the oil, the contents of any butt might be easily and quickly separated into three or four portions of different degrees of value. Mr. Robinson concludes by suggesting the mechanical arrangement, represented by the section of the apparatus in p. 200. *n* is a cistern of water which communicates by the pipe *a* with the bottom of the butt of oil *g*. *f* is the filter raised on feet, and standing on the heading of the butt, with which it communicates by the pipe *b*. *e* is a perforated plate above the lower chamber of the filter, and *k* is its discharging cock; *c* is the middle chamber filled with charcoal, or any other suitable substance. The partition between this and the upper chamber *d*, is a perforated plate, and *l* is the discharging pipe of that chamber. The butt containing the oil being connected with the apparatus already described, the cock of the pipe *a* is to be turned, which will allow the water to flow into the butt. At the same time the cock of the pipe *b* being opened, the upper part of the oil,

and therefore the purest, first flows into, and fills the lower chamber of the filter, and is followed by the less pure portions, according to their respective specific gravity; but as the pipe enters this chamber at the top, those impurities that are considerably heavier than the oil will subside to the bottom, and are from time to time to be discharged through the cock. The rest of the oil rises through the perforated plate, is separated from the lighter impurities by the charcoal or sand in the middle chamber, and then passes through the upper plate into the top chamber, whence it flows through the cock *l*. The two perforated plates must rest on rings or projecting ledges, that the charcoal may be renewed and the lower plate may be taken out occasionally, and cleared of the dregs which otherwise would stop its holes.

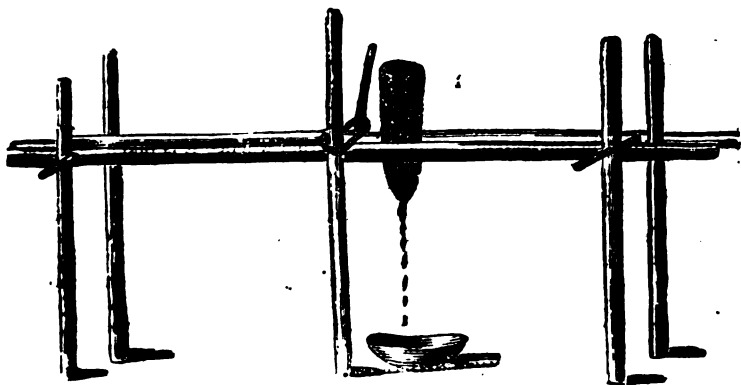
Under the words *ELAINE*, and *FAT*, we have noticed the fine fluid oil that has received the former denomination, and which has been employed for lubricating delicate horological machinery. In this place, we have to describe an improved mode of obtaining it from olive oil by Mr. Henry Wilkinson, of Pall Mall, and which is considered to be peculiarly valuable for lubricating the pivots and other rubbing

surfaces of chronometers. The best olive oil in its recent state, possesses that peculiar bland flavour which fits it for the table, and which appears to arise principally from the quantity of mucilage and water, either held in solution, or mechanically mixed with it. By keeping one or two years in jars, a considerable portion of the mucilage and water subsides, which renders such oil not only cheaper, but better qualified for yielding a greater proportion of pure oil than that which is recently expressed from the fruit. Two or three gallons skimmed from the surface of a large jar that has remained at rest for twelve months or upwards, is preferable to any succeeding portion from the same jar, and may be considered the cream of the oil. Having procured good oil in the first instance, put about one gallon into a cast-iron vessel capable of holding two gallons; place it over a slow clear fire, keeping a thermometer suspended in it; and when the temperature rises to  $220^{\circ}$ , check the heat, never allowing it to exceed  $230^{\circ}$ , nor descend below  $212^{\circ}$ , for one hour, by which time the whole of the water and acetic acid will be evaporated; the oil is then exposed to a temperature of  $30^{\circ}$  to  $36^{\circ}$  for two or three days, (consequently winter is preferable for the preparation, as avoiding the trouble and expense of producing artificial cold); by this operation a considerable portion is congealed; and while in this state, pour the whole on a muslin filter, to allow the fluid portion to run through; the solid, when dissolved, may be used for common purposes. Lastly, the fluid portion must be filtered once or more, through newly prepared animal charcoal, grossly powdered, or rather broken, and placed on bibulous paper in a wire frame within a funnel; by which operation, rancidity (if any be present) is entirely removed, and the oil is rendered perfectly bright and colourless.

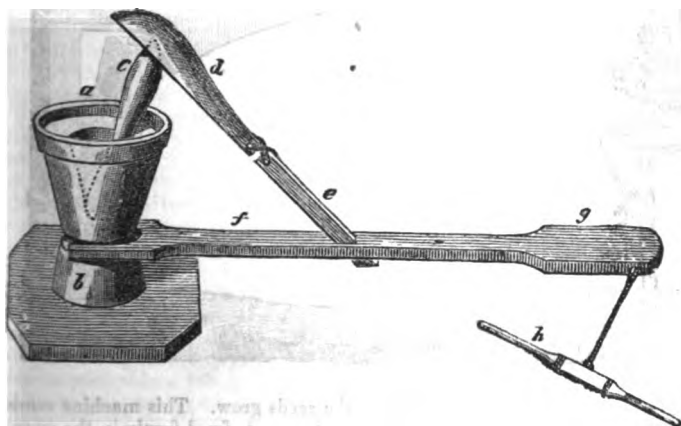
Under the article *CANDLE*, the reader will find accounts of several patented processes for obtaining the *elaine*, or pure oily principle, from the cocoa-nut, palm, and other concrete vegetable oils, so that we need not repeat them under the present head; but the extremely rude and ineffective machinery employed by the natives for expressing oils, in those countries from whence we derive our



applies, is worthy of the attention of the British reader, as exhibiting in a strong light the advantages that might result from the introduction of improved machinery in those parts. Dr. Davy informs us that the means used by the Singalese for this purpose, consists merely of a few upright poles stuck in the ground, supporting two parallel horizontal bars between them; between these, the bags containing the seeds are put, in the manner represented in the subjoined sketch, pressure being given to the bags by means of a perpendicular



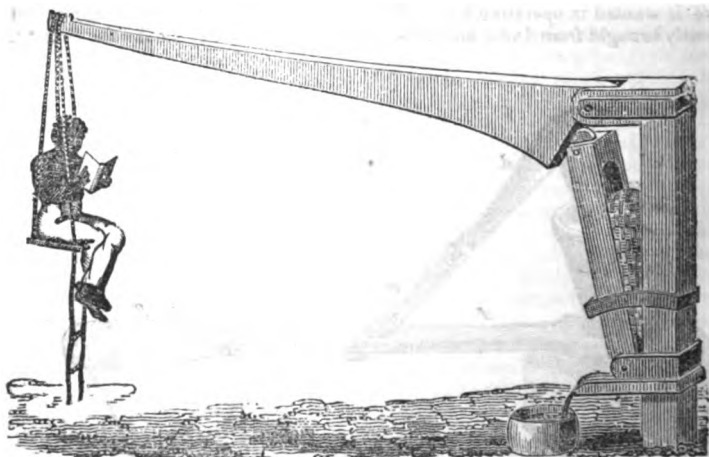
lever which forces the horizontal bars together. The native oil press employed at Madras, and other parts of the East, has somewhat more the character of a machine. The machine is large and substantial, and a great amount of animal force is wanted in operating by it. The annexed drawing is taken from a model recently brought from India and deposited in the museum of the Asiatic Society.



*a* represents a mortar about six feet high, usually formed out of a block of granite, but sometimes of wood; in both cases, there is as much of the substance sunk into the ground as remains above it; *c* is a pestle, the upper extremity of which fits loosely in the piece of timber *d*; at *e* is another piece of timber, attached by

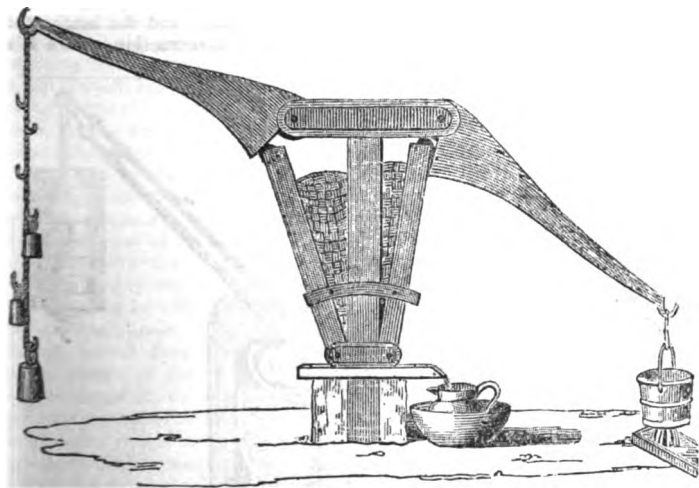


cords to *d*, (by passing round the projecting pins shown) with its lower end mortised and bolted to the horizontal lever *g*; one of the ends of this lever is forked, as at *f*, so as to pass into and around a groove made in the mortar; the lower part *b* of the mortar, enlarged in its dimensions, serves as a rest for the lever *g*, and to give steadiness to the apparatus. To put this machine into operation, a man sits upon the end *g* of the horizontal lever, which by the connecting bars *e* and *d*, cause the pestle *c* to press hard against the sides of the mortar, and a circular motion is given to the pestle by attaching a pair of oxen to the yoke *h*, who draw it round. An oil press on the same principle as this, is described by Dr. Buchanan, as being used by the oil makers of Bangalore for expressing various kinds of oil. These mills receive a quantity of seed, equal to about  $2\frac{1}{2}$  of our Winchester bushels, to which in the course of grinding, about  $2\frac{1}{2}$  quarts of water are gradually added. The grinding continues for six hours, when the farinaceous parts of the seed and the water form a cake, and this having been removed, the oil (about  $5\frac{1}{2}$  gallons in quantity) is found clean and pure in the bottom of the mortar, from whence it is taken by a cup. The mill requires the labour of two men and four oxen, and grinds twice a day, thus making, in the whole, but 11 gallons per day; and if this be all that so large a machine and so great a power can perform, how miserably ineffective must be the Singalese machine we first described. The writer of this article was so forcibly impressed with this defective mode of oil-pressing a few years ago, as to lead him to devise some powerful machine, in which the combinations should be few, of the simplest kind, and that should be easily made by the roughest rural workman at a trifling expense, and be, as much as possible, self-acting. The approbation which the principle of these presses have met with from professional engineers, and the practical experience which the inventor has had of their utility and convenience in a nearly similar application, induces him to give a brief description of them in this place; in the perusal of which the reader will bear in mind that they are especially designed for the rural



manufacture of oil on the spot where the seeds grow. This machine consists simply of three pieces of wood; an upright piece is fixed firmly in the ground, (a tree would answer the purpose well,) near the lower end of which, and also at the upper extremity, are projecting pieces, the upper one forming the joint of the long horizontal lever, and the lower one the joint of the short vertical one; to strengthen these joints a strap of iron is laid over them, and round the upright post, and iron bolts are passed through each to form the centre, or

fulcrum, to each lever; the band near the middle merely serves as a stay to support the vertical lever when it is thrown back. It will be observed that a roller is fixed to the upper extremity of the vertical lever, which, running upon the inclined plane of the horizontal lever, renders the friction of these parts, when in contact, very trifling: but what we consider as the most important result of this peculiar combination of two levers (which are both of the second class) is, that the effect of the power employed is but little at the commencement of the operation, but that the pressure is continually increasing during the operation, and becomes prodigiously great towards the close of it, which is owing to the pressure on the vertical lever constantly accumulating (of itself without attention) as it approaches the fulcrum of the horizontal lever. Now this is precisely what is wanting in oil or wine-pressing: if a great pressure be given at the first, the bags burst and the liquid is lost. It is obvious, from the sketch, that the Indian who is seated in a swing, suspended to the lever, is the acting force; and as this force is obtained not only without labour, but by rest to the individual, there cannot be an easier mode of producing a mechanical effect, especially as some attendance to the process going forward is necessary. A shoemaker, or a tailor, might, indeed, carry on the business of their crafts, and, at the same time, work an oil or a wine-press upon the same principle. The design having been made with reference to the conical bags employed in India for the purpose, will account for this peculiarity in the drawing, as well as in the subjoined modification of the machine, which is merely an extension of the principle to the forming of a double press. By this arrangement double

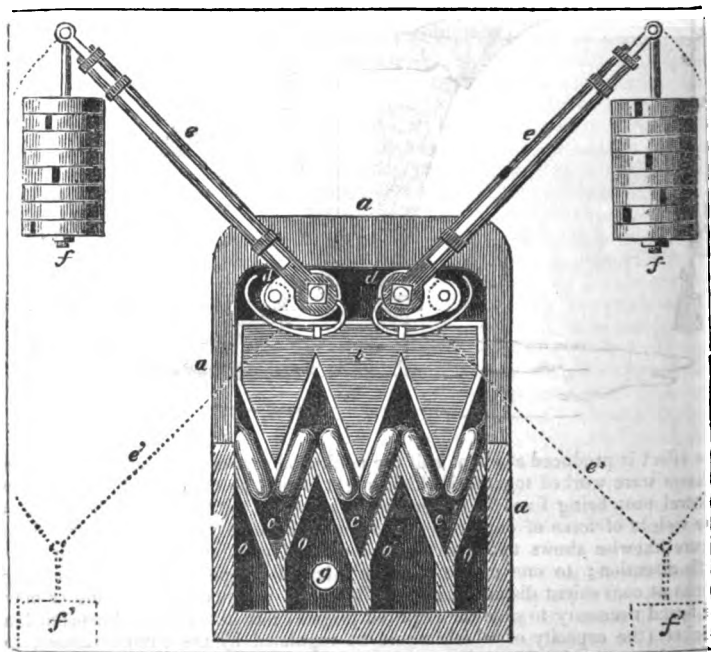


the effect is produced at about half the additional cost of one press; and if both presses were worked together (which might always be the case), instead of the central post being fixed in the ground, it might be put on a movable stand, as the weight of force of one press would counterbalance that of the other. This figure likewise shows two convenient modes of working the press with very little attention; to one of the horizontal levers a rope is suspended, having hooks at convenient distances, upon which such weights may be hung as may be found necessary to give the required pressure; to the other is suspended a bucket (the capacity of which would be regulated by the circumstances), to take advantage of a descending current of water (if the locality admits of it), or of a reservoir, or supply pipe, that might be raised to a proper elevation for filling it; when the operation is completed, as represented on one side of the

press, the bucket falling against a tail-piece fixed upright in a channel or gutter, opens a valve, lets all the water out of the bucket, and relieves the press from the force of its weight. Thus in a situation where water is plentiful, a number of large presses, charged with the necessary materials for obtaining oil, or wine juice, might be filled over-night; the next morning the buckets would be found discharged of their water, and the previously empty recipients be found filled with oil without any attendance whatever. It is, perhaps, deserving of notice, that the self-acting property of these presses adapts them for situations where advantage could be taken of the ebbing and flowing of the tide; the rising of the water would thus fill the buckets, and, upon its falling, leave them suspended with their loads to do the work of the press; the return of the tide would take off the pressure for the renewal of it upon its descent; and thus, every twelve hours, the presses might be worked with almost unlimited power and without any attendance to the moving force.

The most powerful and the most convenient machine for expressing oils, is, unquestionably, the hydrostatic press invented by the late Mr. Bramah. A press of this kind was sent out to Ceylon, by government, in the year 1814, which was made by Mr. Bramah expressly for the purpose of expressing oil from the cocoonut kernel; a very full description of all the important details of which is given in the thirty-fourth volume of the *Transactions of the Society of Arts*. But although the hydrostatic press is the most economical machine that the capitalist can employ, its expense is unsuited to the means of the small, or middle, manufacturers, to whom a press of some kind is indispensable; accordingly, the following one has been designed to meet their wants.

The annexed figure gives a front view of the machine, excepting that the front plate which encloses the lower part of the machine, and the bearings of the axes of the cams are removed to show better the construction. *aaa* is a



strong frame of cast-iron (it may be of wood strongly bolted together); the size may be as circumstances may require; but a convenient size would be 3 feet

high, two feet wide, and 1 foot from front to back. *b* is the pressing-head, of solid wood, formed into three wedge-shaped teeth, and made so as to fit into a bed *eee*, of a corresponding figure; *dd* are two cams, firmly attached to two expanding levers *ee*, which are loading at their extremities by suspending thereto any required number of flat circular weights: to each of the cams a strong hook, bent to the figure of the former, is fixed; and these hooks passing through eyes, or staples, in the head of the press, lift it up when the pressure is taken off, allow it to descend without obstruction, and keep them always connected. At *g* is an aperture for conveying, by means of a pipe, hot air, or steam, into the chambers *ooo*, which have lateral openings one into the other; the angular roof of this chamber adapts it for collecting the heat, air, or vapour, whence it passes through the interposing iron plates into the bags under pressure. The bags being placed between the wedges as shown, the pressure is given by loading the levers (which may be drawn out to any length required), which gradually causes them both to descend to the position shown by the dotted lines *e'e'* and *f'f'*; at which time the cams have turned a quarter round, so as to attain a vertical position when their utmost effect is produced. The bags between the wedges are thus compressed by a great force, and their contents reduced to hard dry cakes, while the expressed oil runs off in the angular gutters at the bottom, and is conducted out of the machine, by a pipe, into a proper recipient.

The operation being completed, the pressure is taken off by removing the weights (already close to the ground), and throwing up the levers which lift the head of the press, the chief labour of which may be obviated by a counter-balance weight. The oil cakes being taken out of the press, other bags, previously prepared, are put in their place, and the operation renewed simply by loading the levers, leaving them to do their work unassisted, and accumulate in power as they move through their assigned space. It should here be observed, that owing to an oversight in the drawing, the levers are not shown as fixed in the best position for commencing the operation. They should be placed slightly inclined from the vertical position; the power would then be considerably lessened at the beginning, and vastly increased towards the end. The extremities of the cams are furnished with strong anti-friction rollers, which come into action at the end of the process.

The action and power of this press may be described and estimated thus: the levers *ee* being fixed to the cams act with them as entire pieces, hence must be regarded as two bent levers, in which the points of pressure are constantly changing their position. Now supposing 5 cwt. appended to each lever, and each lever when drawn out to be ten feet long, and the pressure to be given at one inch from the fulcrum, this would give a power of 120 to 1, or 60 tons upon the head of the press. The head of the press, it will be observed, moves through a space, the treble of that which is between the opposite planes of the wedge-formed teeth; consequently, the power is here increased threefold, or raised to 180 tons; then, by applying similar levers and weights to the opposite ends of the axes of the cams, we have the force of 360 tons upon the goods in this little self-acting lever press. The friction in such a machine is undoubtedly considerable, but as any additional force within the limits of the strength of the structure may obviously be added, and the point of pressure be brought nearer to the fulcrum than the distance mentioned, at the close of the operation, any required power may be obtained at the period when it is wanted, to squeeze the cakes thoroughly dry. The oil-maker will do well to consider, that the force transmitted to the screw presses as well as by the hydrostatic is *intermittent*, and not a *constant self-accumulating force*, as exerted by the lever presses we have just described.

**Put Oil.**—In the Greenland fisheries, the blubber produced from whales is cut into small pieces and packed in casks, and when it arrives in England, it is in a putrid state. It is started into a large receiver, containing about twenty tons. There is a semicircular wire grating in the side of the back, close to the bottom, through which the fluid parts drain, the wires being sufficiently close to prevent the pieces of blubber from passing. The oil, as it drains through this grate, is to be conducted by means of a copper pipe into another back, containing

about the same quantity. When this receiver is full, it is left two or three hours to settle, and then conducted by a sluice into a copper heated by a fire in the usual way. The oil is stirred until it has acquired heat equal to 225° Fahrenheit; this destroys the rancidity, and causes the mucilaginous matter to settle at the bottom. As soon as the oil has received the before-mentioned heat, the fire must be drawn, and about half a tun of cold water pumped upon the surface of the oil, which descending cools the bottom of the copper, and prevents the adhesion of the mucilaginous matter thereto. The oil may then be run off into coolers, and when quite cold be drawn off into casks for use.

Whale oil may, however, be purified, by a system of filtering, without the aid of heat. For this purpose, the long cylindrical bags used by the sugar refiners are sometimes employed. These are about 40 inches long, and 13 inches wide, their mouths being distended by wooden hoops. They are made of stout canvass, lined with flannel; and between these two substances a packing of powdered charcoal, or bone black, is quilted throughout in a stratum of about an inch thick, which detains the gelatinous matter, and other impurities. This oil is received in a cistern, containing water at the bottom to the depth of about 6 inches, in each 20 gallons of which is dissolved about an ounce of blue vitriol, which nearly divests it of the impurities that escaped the filter, and of the unpleasant odour it had before. But it is further cleansed by a second washing, in another cistern of water, wherein it is allowed to remain for several days, and then filtered several times through charcoal; and lastly, by filtering through canvass and flannel without charcoal.

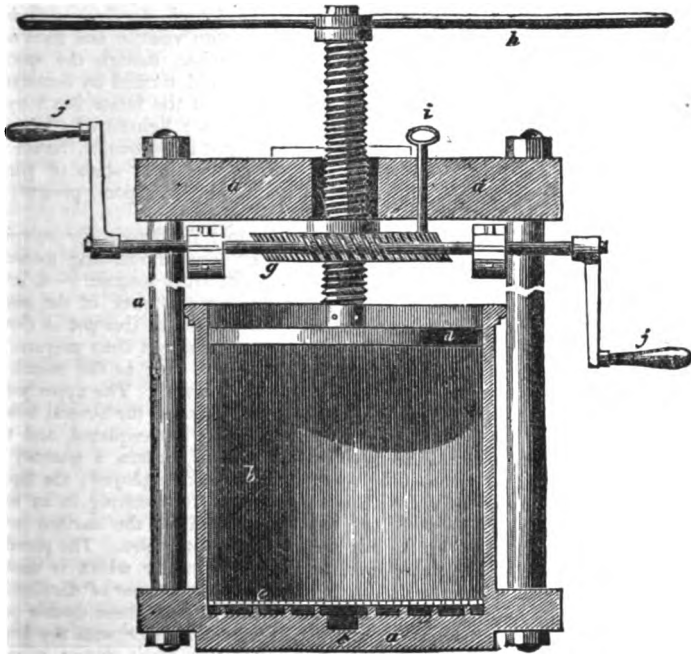
Amongst the numerous papers on this subject that have appeared in the scientific journals, we select the following process, recommended by Mr. Dossie, where the utmost purity is required, and particularly for the woollen manufacture.

“Take a gallon of crude stinking oil, and mix with it a quarter of an ounce of lime slaked in the air, and half a pint of water; stir them together, and when they have stood some hours, add a pint of water, and two ounces of pearl ashes, and place them over a fire that will just keep them simmering, till the oil appears of a light amber colour, and has lost all smell, except a hot, greasy, soaplike scent. Then superadd half a pint of water, in which an ounce of salt has been dissolved; and having boiled them half an hour, pour them into a proper vessel, and let them stand till the separation of the oil, water, and lime be made, as in the preceding process. Where this operation is performed to prepare oil for the woollen manufacture, the salt may be omitted; but the separation of the lime from the oil will be slower, and a longer boiling will be necessary. If the oil be required yet more pure, treat it after it is separated from the water, &c. according to the second process, with an ounce of chalk, a quarter of an ounce of pearl ashes, and half an ounce of salt.”

In the South-Sea fishery, the whalers bring home their oil in casks. In consequence, however, of the wasteful and dangerous nature of the process adopted for obtaining the oil from the blubber, some presses have lately been sent out by the ships to express the oil from the pieces of the blubber that have been boiled, but in which a great quantity of oil still remains. All this oil was formerly allowed to remain in these pieces, called “scraps,” and was with them made use of merely as fuel, and burned under the “try-pots” or boilers; but in consequence of the extreme inflammability of the oil, and its great superabundance, serious accidents occurred by the flames issuing from the furnace, and catching the oil in the try-pots. By the use of the subjoined machine (in p. 204) we understand that the danger beforementioned has been obviated, and the oil contained in the scraps, which was before wasted, now forms a sensible portion of a ship's cargo. It is the invention of Mr. John Blythe, an intelligent engineer, of Limehouse.

*Description.*—*a a a a* is the frame of the press, consisting of a strong cast-iron bed and head, and wrought-iron jambs, secured at each end by nuts and screws; *b* is a hollow cylinder, with an iron plate perforated with small holes, resting upon ribs in the bottom of the cast-iron cylinder, as shown at *e*; *c* is a spout for allowing the oil to run off; *d* is a follower, also made of cast iron; *f*

a screw made of wrought iron, and fitted into an internal screw in the wheel *g*; *h* is a lever for screwing down the follower, when great speed and but little pressure is required. *i* is a bolt which is put in to prevent the wheel *g* from turning round, which then becomes a box for the screw to work through; when greater pressure is necessary, this bolt is withdrawn, and the power of one or more



men applied to the handles *jj*, which turn an endless screw, and give motion to the wheel, as shown at *o*; the wheel in its revolution bites upon the underside of the head of the press, and consequently forces the screw downwards, with the increased power of the endless screw and wheel and main screw. The scraps are put into the cylinder warm, with a mattress, (wicker basket,)  $\frac{3}{4}$  of an inch thick in the bottom, to prevent the hard substance from filling up the holes at *e*. After the press is charged, it is set to work by first screwing down with the single power of the screw and lever, and finished by adding the power of the wheel and endless screw.

*Native Oil of Laurel.*—This extraordinary and valuable production is supposed to be the only known instance of a perfectly volatile liquid obtainable without the aid of art. It is yielded by a tree of considerable height, which is found in the vast forests that cover the flat and fertile regions between the Orinoko and the Parime, in South America. The wood of this tree is aromatic, compact in its texture, and of a brownish colour, and its roots abound with essential oil. The oil is procured by striking with an axe the proper vessels in the internal layers of the bark; while a calabash is held to receive the fluid which gushes out in such abundance, that several quarts may be caught from a single incision, if the operation be performed with dexterity. In many respects the native oil resembles the essential obtained by expression, distillation, and other artificial processes: it is, however, more volatile and highly rectified than any of them, its specific gravity hardly exceeding that of

alcohol. When pure it is colourless and transparent; its taste is warm and pungent; its odour aromatic, and closely allied to that of the oily and resinous juice of the conifera. It is volatile, and evaporates without residuum at the ordinary atmospheric temperature. It is inflammable, and, except when mixed with alcohol, gives out in its combustion a dense smoke. Neither the acids nor the alkalies seem to exert any sensible action upon the native oil; when combined, however, with sulphuric acid, the mixture assumes a momentary brownish tinge, but soon regains its transparency. The oil of laurel dissolves camphor, caoutchouc, wax, and resins, and readily combines with volatile and fixed oils. It is insoluble in water; soluble in alcohol and ether, though the specific gravity of the oil exceeds that of ether; the compound formed by combining them in the proportion of part of the former to two of the latter floats upon the surface of pure ether; and may, therefore, be the lightest of all known fluids. To the chemist, and the vegetable physiologist in particular, native oil of laurel, elaborated by the unassisted hand of nature, in a state of purity which the operose processes of art may equal, but cannot surpass, presents an interesting subject of inquiry, and a wide field of speculation.

*The Oil of Birch Bark*, which is so much used in Russia for currying ether, to which it gives a peculiar odour, and a power of resisting moisture beyond any other dressing, is prepared in the following manner:—A large earthen pot is filled with the thin white paper-like external bark of the birch-tree, carefully separated from the coarse bark; the mouth of this pot is closed with a wooden bung perforated with several holes. The pot thus prepared is then turned with the mouth downwards, and luted with clay to the mouth of another pot of the same size, which is buried in the ground. The upper pot is now surrounded with fuel, and a fire is made and continued for several hours, according to the size of the pot. When the operation is completed, and the apparatus cooled and unluted, the lower pot is found to contain a quantity of liquid equal to about 60 per cent. by weight of the bark employed; the liquid consisting of a brown oil mixed with pyroligneous tar, swimming in an acid liquor. In some places iron pots have been substituted for the earthen pots, the mouths being separated by an iron plate pierced with holes. The peculiar odour of the oil is supposed to be owing to a resinous matter which is melted out of the bark; and drops into the lower pot during the process of distillation. In conducting this operation on the large scale, a number of these double pots may be placed in the horizontal bed of a reverberatory furnace, with the lower pots imbedded up to their necks in sand; by which arrangement a great economy of fuel and labour will be attained.

For further information on the nature and applications of oil, see the articles SPERMACETI, TALLOW, WAX, CANDLES, FAT, SOAP, ELAINE, STEARIN, LIXE, (Printers') ESSENTIAL OILS, &c.

**OIL-COLOUR CAKES.** A convenient preparation for the use of artists, invented by Mr. George Blackman, for which that gentleman was awarded a medal by the Society of Arts. Take, says Mr. Blackman, of the clearest gum mastich, reduced to fine powder, four ounces; of spirits of turpentine, one pint; mix them together in a bottle, stirring them frequently till the mastich is dissolved: if it is wanted in haste, some heat may be applied, but the solution is best when made cold. Let the colours to be made use of be the best that can be procured, taking care that by washing, &c. they are brought to the greatest degree of fineness possible. When the colours are dry, grind them on a hard, close stone, (porphyry is the best,) in spirits of turpentine, adding a small quantity of the mastich varnish. Let the colours so ground become again dry, then prepare the composition for forming them into cakes in the following manner:—Procure some of the purest and whitest spermaceti you can obtain; melt it over a gentle fire in a clean earthen vessel; when fluid, add to it one-third of its weight of pure poppy oil, and stir the whole well together; these things being in readiness, place the stone on which your colours were ground on a frame or support, and by means of a charcoal fire under it make the stone warm; next grind your colour fine with a muller, then adding a sufficient quantity of the mixture of poppy oil and spermaceti, work the whole together

with a muller to a proper consistence; take then a piece of a fit size for the cake you intend to make, roll it into a ball, put it into a mould, press it, and it will be complete. When these cakes are to be used, they must be rubbed down in poppy, or other oil, or in a mixture of spirits of turpentine and oil, as may best suit the convenience or intention of the artist.

**OPERA-GLASS.** A short kind of telescope, used chiefly in theatres; it is sometimes called a "diagonal perspective," from its construction. It consists of a short tube, in each side of which there is a hole exactly against the middle of a plane mirror, which reflects the rays falling upon it to the convex glass, through which they are refracted to the concave eye-glass, whence they emerge parallel to the eye at the hole in the tube. This instrument is not intended to magnify objects more than about two or three times. The peculiar artifice is to view a person at a small distance, so that no one shall know who is observed, for the instrument points to a different object from that which is viewed; and as there is a hole on each side, it is impossible to know on which hand the object is situated which you are looking at.

**OPIUM.** An inspissated gummy juice, which is obtained chiefly from the white poppy of the East (*papaver somniferum*). It may also be obtained, but in a small quantity, from the other species of poppy. It is imported from Persia, Arabia, and other warm parts of Asia, in flat cakes, covered with leaves, to prevent their sticking together. It has a reddish brown colour, and strong peculiar smell; its taste is at first nauseous and bitter, but this soon becomes acid, and produces a slight warmth in the mouth. In Turkey the white poppy is in great cultivation, for the purpose of affording opium. After the flowering of the plant, when the capsule containing the seed has arrived at its full growth, slight longitudinal incisions are made in the capsules towards the evening. A milky juice oozes out, which is collected the next day. The excess of moisture being evaporated in the sun, it assumes the consistency fitted for making it into cakes, in which state it is found in commerce. This is called Turkey opium, to distinguish it from another kind brought from the East Indies, which is generally softer than the Turkey, of a darker colour, less bitter, and more disagreeable to the taste, and has an unpleasant empyreumatic smell. When opium is soft and friable, of a blackish colour, and has an empyreumatic smell, it is bad: its taste should be bitter, but not sweet.

**OPOBALSAM.** The most precious of the balsams; or that commonly called Balm of Gilead. The true balsam is of a pale yellowish colour, clear and transparent, about the consistence of Venice turpentine, of a strong, penetrating, agreeable aromatic smell, and a slightly bitterish pungent taste.

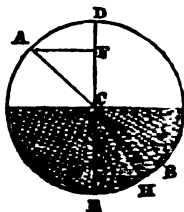
**OPODELDOC.** A solution of soap and alcohol, with the addition of camphor and volatile oils. It is used, externally, against rheumatic pains, sprains, bruises, and other like complaints.

**OPTICS.** The science which treats of the nature of light, and the phenomena of vision. Our prescribed limits will not allow of our giving more than a brief outline of the elements of this sublime science, which has employed the pens of some of the most illustrious philosophers in successive ages, whose works upon it are both elaborate and numerous. For the larger portion of the matter on this most interesting branch of natural philosophy, we are greatly indebted to Mr. A. Pritchard, and other modern authors of eminence.

The natural progress of the rays of light is in straight lines; yet, like all other matter, light is influenced by attraction, which sometimes turns it out of its direct course; this happens when it passes out of one medium into another of different density, as from air into water or glass, or from water or glass into air. This disposition or capability of light to be bent, is called its *refrangibility*; and the change of direction actually assumed, when the rays enter another medium, is called *refraction*. A very easy experiment will convince any one that light is influenced by some peculiar law when entering or leaving one medium for another. Put one end of a stick into water, and it will appear as if it were broken. This effect is owing to the rays of light being attracted or drawn out of their direct course on entering the denser medium of the water. It is necessary, however, to observe, that only those rays which enter another medium



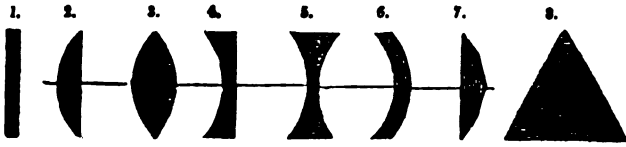
*obliquely*, suffer refraction; for rays which fall perpendicularly are equally attracted on all sides, and, therefore, have no tendency to deviate in any direction. If a shilling, or any other conspicuous but small object, be placed at the bottom of a basin, and the spectator retire to such a distance that the edge of the vessel just prevents its being seen, and the vessel be then filled with water, the shilling will become perfectly visible, though neither it nor the spectator change their place in the slightest degree. In this experiment the spectator looks at the shilling in an oblique direction, and the rays proceeding from it, by which it is rendered visible after the water has been poured in, are bent towards his eye on entering the air. The greater the density of any medium, the greater is its refractive power; and of two refracting media, that which is of an oily or inflammable nature, will have a greater refracting power than the other. The *incident angle* is the angle made by a ray of light and a line drawn perpendicular to the refracting surface, at the point where the ray enters the surface; and the *refracted angle* is the angle made by the ray in the refracting medium, with the same perpendicular continued. The *sine* of the angle is a line which serves to measure the angle, being drawn from a point in one leg, perpendicular to the other. In the subjoined figure ACD is the *incident angle*, HCE the *refracted angle*, and BCH the angle of *deviation*; AF is the sine of the angle of incidence; and HG the sine of the angle of refraction. It may seem extraordinary that light should pass more directly through a dense than through a rare medium; but it has been ascertained that light is subject to attraction; and Sir Isaac Newton discovered and demonstrated that this power is the cause of refraction. The truth of this theory is confirmed by the fact, that the change in the direction of the ray commences, not, as might be supposed, when it comes in contact with the refracting medium, but a little before it reaches the surface; and the incurvation augments in proportion as it approaches the medium.



The term *lens* is given to any transparent substance, as glass, crystal, water, or diamond, having one or both surfaces curved to collect or disperse the light transmitted by it. The lenses in general use are made of glass, and are usually called magnifying glasses. Glass, however, does not possess a greater share of the magnifying property than other transparent substances. Mankind have availed themselves of the principle of refraction to excellent purpose in the construction of lenses; for, by grinding the glass or other substance thinner at the edges than in the middle, those rays of light which would strike upon it in a straight line, or perpendicularly, if it were plain, strike upon it obliquely, and the refraction they suffer, causes them to *converge*; on the contrary, by making the glass thinner in the middle than at the sides, the rays are refracted the contrary way, and, therefore, become *divergent*. The nature of refraction through lenses may, perhaps, be rendered more clear, if we reflect that all curved surfaces are composed of straight lines or points, infinitely short, and inclining to each other like the stones in the arch of a bridge. When parallel rays fall upon a surface of this sort, it is evident that those only which enter the middle part will go on in a straight direction; those which strike the sides will strike them obliquely, and will, consequently, be made to converge. If the surface be a perfect curve, it is clear that only the ray that strikes the centre of the curve will enter it in a straight direction; all the rest will be more or less refracted, according to the degree of obliquity with which they strike the surface, and the whole of the refracted rays will converge to a point called the focus.

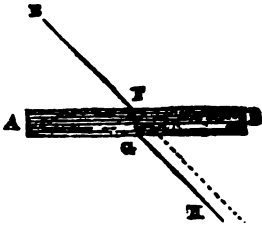
Glasses, or lenses, are usually ground for optical purposes into eight different forms. 1. The lens may be flat on both sides, like the pane of a window. 2. It may be flat on one side, and convex on the other. 3. It may be convex on both sides. 4. It may be flat on one side, and concave on the other. 5. It may be concave on both sides. 6. It may be convex on one side, and concave on the other. 7. It may have one side, which must be convex, ground into *littles*

facets, while the other side is plain. 8. It may have considerable length in a triangular form. No. 1 is called a plane glass or lens, as its sides are parallel;

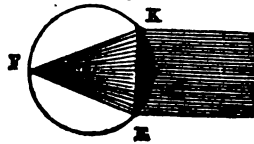


No. 2, a plano-convex lens; No. 3, a double convex; No. 4, a plano-concave; No. 5, a double concave; No. 6, a meniscus; No. 7, a multiplying glass; and No. 8, a prism. The term *lens* is usually given to such glasses or substances only as either magnify or diminish. Nos. 2, 3, 4, and 5, are therefore lenses; No. 6 is also a lens when its surfaces are portions of different spheres; but when they are of equal radii, or parallel, it has only the effect of a plane glass. A ray entering the plane glass, No. 1, will be refracted; but it will undergo another refraction on its emergence, which will rectify the former; the place of the object will, therefore, be a little altered, but the figure will remain the same. Suppose *AB*, *Fig. 1*, to represent a solid piece of glass with two parallel surfaces, an incident ray *EF* will be refracted into *FG*, and *FG* will be refracted on passing from the second surface into *GH*, parallel to the original direction *EF*. If parallel rays enter the plano-convex glass, as shown by

*Fig. 1.*



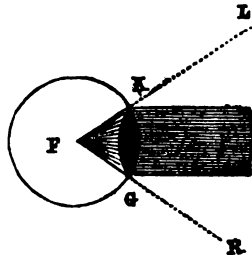
*Fig. 2.*



*Fig. 2*, the ray *E* will be refracted upwards to *F*, and the ray *K* will be refracted downwards to the same point; there they will cross, and then go onward in a straight line, and continue to diverge till intercepted by some obstacle.

When parallel rays fall upon a double convex glass, *K G*, they will be refracted still more abruptly, and meet sooner in a point or principal focus at *F*. The distance of this focus is equal to the semi-diameter of the circle which the convexity of the glass continued, would produce. Either this glass or the former, as they collect the rays of the sun into a point, will burn at that point, the whole force of the rays that pass through them being concentrated there.

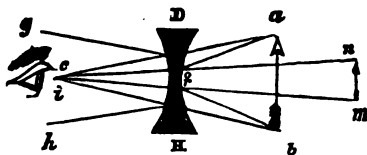
From all luminous objects, the rays of light proceed in a state of divergence; but when the distance from which they come is very great, the quantity of divergence is too small to require notice. The fixed stars and the sun, for example, are so immensely distant, that their rays are always considered as parallel; and it is only parallel rays which are converged to a focus in the manner described. Divergent rays proceeding from a point, as the flame of a candle, will be differently affected. If, therefore, a candle be placed exactly at the focal distance of a single or double convex



lens, the rays will emerge parallel to each other. If the candle be placed nearer to the glass than its focal distance, the rays, after passing through the glass, will no longer be parallel, but separate or diverge. If the candle be placed still further off, the rays will then strike the glass more nearly parallel, and will, therefore, upon passing through, converge or unite at a distance behind the glass, more nearly approaching the distance at which parallel rays would be converged. After the rays have united in a focus, they will cross each other, and form an inverted picture of the flame of a candle, which may be received on a piece of paper placed at the meeting of the rays behind. The cause of the inversion of the image is evident, the upper rays being those which come from the under part of the luminous body; and the under rays, on the contrary, coming from the upper part.

In looking through a plano-convex or double convex lens, the object appears magnified agreeably to the rule, that we see every thing in the direction of the lines in which the rays last approach the eye; consequently, the larger the angle under which an object is seen, the larger that object will appear. From lenses the reverse in form to those we have noticed, we naturally expect opposite effects; accordingly, the attractive and refractive powers of a plano-concave and double-concave lens are not towards the centre, but towards the circumference. Parallel rays falling upon these lenses diverge, or are dispersed. Rays already divergent are rendered more so, and convergent rays are made less convergent; hence objects seen through one of these glasses appear smaller than to the naked eye. Let  $ab$ ,

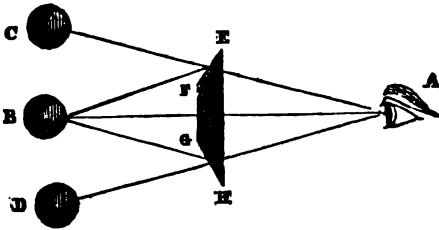
in the subjoined figure, represent an arrow, which would be seen by the eye, if no lens were before it, by the convergent rays  $acbi$ ; but if the double-concave glass  $DH$  be interposed between the object and the eye, the ray  $ac$  will be bent towards  $g$ , and the ray  $bi$



will be bent towards  $h$ , and consequently both will be useless, as they do not enter the eye. The object, then, will be seen by the rays  $acbr$ , which, on entering the glass, will be refracted into the lines  $oc$  and  $ri$ ; and, according to the rule laid down, the object will be seen in the last direction of these rays; therefore, as the angle  $ocr$  is so much smaller than the angle  $acb$ , the arrow necessarily appears diminished; and as, with the diminution of its apparent size, we connect the idea of its being further off, it seems to be at the distance  $nm$ .

The miniscus acts like a convex lens when it is thickest in the middle, that is, when its convex surface is a portion of a less sphere than its concave one; on the contrary, when it is thinnest in the middle, or has its concave surface a portion of a less sphere than the other, it has the effect of a concave lens. The axis of a lens, is a line supposed to be drawn through the centre of its spherical surfaces. When one side of the lens is plane, the axis is perpendicular to that side. The axis of a lens continued, would pass exactly through the centre of that sphere, of which the lens is the segment. The focus of a plano-convex lens is at a distance from the convex surface equal to the diameter of the sphere of which it is a part; and that of a double and equally convex lens is at half the same distance. The distance of the focus of a solid globe or ball of glass is one quarter of its diameter from the nearest part of the ball. To explain the effect of the multiplying glass, (No. 7,) it will only be necessary to revert to the principle, that objects appear in the direction of the line last described by the rays that render them visible; hence, if the object B, (p. 213.) is seen through the glass  $EH$  by the ray  $BA$  that passes through the surface  $FG$ , the object, by the eye at  $A$ , will be seen at  $B$ ; the ray  $BG$  passes through the surface  $GH$ , and after refraction comes to the eye in the direction of  $AD$ , as it proceeded from  $D$ , and therefore the object appears at  $D$ ; and for the same reason, through the surface  $FE$ , it appears at  $C$ ; consequently, there will be the appearance of as many objects as there are flat surfaces on the glass, for

each of them shows the same object in a different place. The disposition of the rays of light to be turned back into the medium from whence they came, is



called their *reflexibility*; the change of direction produced by their being actually turned back, is called *reflection*. All objects which are not themselves luminous are rendered visible by reflection; and glass, crystal, water, and the most pellucid media, reflect a portion of the rays of light which fall on them, or their forms and substance could not be distinguished. On the other hand, the whole of the incident light is not reflected from any surface, however bright, smooth, and opaque. It is calculated that the best mirrors reflect little more than half the light they receive; the part lost consists of two portions, one of which, and by far the largest, being absorbed by the mirror, and the other, scattered by irregular reflection. Light is always lost, in passing through the most transparent bodies, by the same laws.

The different refrangibility of the rays of light is demonstrated by the prism. If a beam of light from the sun be let into a darkened room, and be received upon a white screen or opposite wall, it will form a circular image, and will be of one uniform whiteness. If a prism be interposed, so that the light must pass through it before it reaches the wall, the image is no longer circular or white; it assumes an oblong shape, terminated by semicircular arches, and exhibits seven different colours. This oblong image is called the spectrum. In the whole range of philosophical experiment, a more beautiful appearance cannot be presented to the eye, and instructive nature will appear not less extraordinary than its beauty, when it is considered, that the investigation of the cause of it led Sir Isaac Newton to form the first rational theory of the cause of colours. The seven colours of the spectrum are called the original, or primary colours. If a spectrum be divided into 100 parts, the red part of it is found to occupy 11 of these parts; the orange 8, the yellow 14, the green 17, the blue 17, the indigo 11, and the violet 22. The red part of the spectrum is nearest the prism; and the violet, at the greatest distance. It is clear, from this, that light is not homogenous, because the attractive power of the prism is greater upon some parts of it than upon other parts. Accordingly, it is generally concluded that the solar beam or white light is composed of particles differing in size and density; that this difference of their size and density is the cause of their being differently refrangible; and that the separation of the rays of one or more sizes from the rest, by various means, produces all the diversity of colours which affect our sight. It is found, that the red part of light is capable of struggling through thick and resisting mediums, when all the other colours are stopped. Thus, the sun appears red when seen through a fog. The particles which compose orange light are next, in size and refrangibility, to the red; and so on to the violet, which consists of the smallest particles, and which are, therefore, the most turned out of their course. White is composed of all the primary colours, mixed together in their due proportions. When bodies reflect the rays of light in the proportion in which they exist in the solar beam, they appear white; when they reflect none of the rays, they appear black.

Convex lenses in their simple state have been applied to collect the heat of the sun's rays, for purposes similar to those of burning mirrors. A burning

lens must be convex; a burning mirror, concave; because both produce their effect by concentrating into a focus the rays of light and heat incident upon a large surface. As the rays which pass through a convex lens, or are reflected from a concave mirror, are united at its focus, their effect is so much the greater, as the surface of the lens or mirror exceeds that of the focus. Thus, if a lens four inches in diameter collect the sun's rays into a focus at the distance of one foot, the focal image will not be more than one-tenth of an inch broad. The surface of this circle is 1600 times less than the surface of the lens, consequently the density of the sun's rays within it is proportionately increased. It has been found, that large lenses and mirrors burn with irresistible intensity when properly constructed, dispersing the hardest metals and other substances into gas, often in a few seconds. See BURNING GLASS, and the various other optical instruments, under their respective names.

**ORES.** The natural bodies whence metals are extracted. Metallic substances, when found pure, are called native; but when combined with other substances, as they generally are, they are denominated ores. As it is of the utmost importance to be acquainted with the materials of which ores are composed, as well as the simplest and easiest processes by which they may be separated from each other, we deem it necessary to give the following brief account of the modes of reduction usually adopted.

*Ores of Gold.*—Gold exists in nature only in the metallic state; but it is scarcely ever found perfectly pure, for it is alloyed in different proportions with silver, copper, tellurium, and some other metals. When it is alloyed with silver or copper, or even with both, the gold retains its ductility; but when combined with tellurium, its distinctive characters entirely disappear. The presence of gold may easily be detected by treating the mineral supposed to contain it with nitro-muriatic acid, and dropping muriate of tin into the solution. If the solution contains any gold, a purple precipitate immediately appears. Native gold ought to be dissolved in nitro-muriatic acid; the silver, if any is present, falls to the bottom in the state of muriate, and may be separated by filtration, and weighed. Pour sulphate of iron into the solution, and the gold is precipitated in the metallic state. The copper, if any is present, may be precipitated by means of a plate of iron; the presence of iron may be ascertained by dropping tincture of nutgalls into a portion of the solution. The auriferous pyrites may be treated with diluted nitrous acid, which dissolves the iron, and separates the sulphur; the gold remains insoluble, and is found in the state of small grains. In the Hungarian gold mines, which are the richest yet known in the old continent, the attention of the miner is not merely limited to the strings of ore, but to the whole contents of the vein, which are usually extracted, and raised to the surface in large masses. These masses are distributed to the workmen, who break them down, first with large hammers, and afterwards with smaller ones, till they are reduced to pieces of the size of a walnut; the native gold, with the matrix attached to it, is again to be broken by hand into still smaller pieces, by which means other impurities and stony matters are separated. The ore is then introduced into a wooden box, floored with cast-iron plates, and, by the action of two or more heavy spars of oak, which are shod with iron, and alternately worked like the common stamping mill, it is reduced to a fine powder; this powder, which is called flour, is then removed into a vessel like a large basin, and mixed with such a quantity of salt and water as will render it damp; the workman then takes a thin, porous leather bag, introduces a quantity of mercury into it, and, by regular and continued pressure, forces the mercury, in very minute drops, through the leather. In this divided state it falls upon the pulverised ore, and is immediately kneaded up with it, till the requisite quantity, which depends on the proportion of gold, has been added. After completing this part of the process, the next object is to incorporate the mercury and gold: this is effected by rubbing the mixture together for some time by means of a wooden pestle; the mixture is then heated in a proper vessel, and subjected, for three or four days, to the temperature of boiling water; and, lastly, the mixture is to be carefully washed by small parcels at a time, so that the earthy particles may be carried off by the water; the mercury, combined with the gold, only remains

behind in the form of amalgam. A portion of this mercury is then separated by pressure, in a leathern bag, and the remainder is driven off by distillation, leaving behind the gold and silver, with which it may be alloyed. When this metal is found in other ores, they are first roasted, to disperse the volatile principles, and to oxidize the other metals. The gold, which is but little subject to oxidation, is extracted by amalgamation or by cupellation, or either methods, adapted to each ore, according to its properties or constituent parts. The metal obtained in these ways is always more or less alloyed, particularly with silver and copper. The first step in its purification is the process of cupellation. (See *CUPELLATION*.) The gold, after it has been submitted to this process, is often alloyed with silver, which, being nearly as difficult of oxidation, is not removed by the action of lead; and hence the necessity of the operation denominated *parting*, for which see *PARTING*.

*Ores of Platinum.*—The whole of the platinum which has been brought to Europe, has been previously subjected to the process of amalgamation in South America; and hence it happens that a small quantity of mercury remains in it. In treating the ores, therefore, the first object is to separate the mercury by means of heat, either in an open ladle, or in an earthy retort; the platinum remaining after the mercury is thus driven off, appears much yellower, because the particles of gold dispersed through it exhibit their peculiar colour. Proust's method of analysis is, first, to separate the sand with which the grains of platinum are mixed, by exposing them to a blast of air. By heat he evaporates the mercury, which still adheres to them, and then picks out the grains of gold, which are always mixed with platinum, and which are thus rendered visible. The ore is then dissolved in an acid composed of one part of nitre, and three parts of muriatic acid; a black powder remains: this powder, when roasted, gives out phosphorus and sulphur. After the separation of the gold, nitromuriatic acid being poured on the remaining mass will dissolve it, with the exception of a small quantity of black matter, which was formerly mistaken for plumbago, but is now proved to be a compound of osmium and iridium, two of the four new metallic bodies, which were discovered a few years ago by Mr. Tennant. These two metals Dr. Wollaston has since shown to exist also in the crude platinum ore, united together in the form of distinct minute crystals, and dispersed through the other grains, from which they can be distinguished and picked out without difficulty. Muriate of ammonia being now added to the solution, the platinum is precipitated in the form of a yellowish powder, which is a compound of muriatic acid, ammonia, and platinum: the remaining solution, after the platinum has been separated from it, still contains, besides iron, minute quantities of various other substances, amongst which the two other metallic bodies, palladium and rhodium, were discovered by Dr. Wollaston. Having now brought the platinum to the state of salt, the next object is to restore it, thus purified, to its metallic state, and to consolidate it into a malleable mass; this, from the great infusibility of platinum, has long been a matter of considerable difficulty and labour. It had been long discovered that arsenic readily united with platinum, and formed with it an alloy of great fusibility; an alloy, therefore, was made of crude platinum and arsenic; and the latter metal, being easily volatilized, was driven off by heat, whilst the iron, being oxidated during the process, was also separated from the mass; so that the platinum was left in an impure but malleable state.

*Ores of Silver.*—The analysis and reduction of these different ores, it is scarcely necessary to observe, must be conducted according to the nature and proportion of the ingredients which enter into the composition of the ore to be examined or reduced. Pure native silver requires no other assay than fusion, with a little potash to free it from its earthy matter. In the humid way, the silver may be dissolved in nitric acid, and precipitated by common salt; the precipitate may then be fused with soda in a crucible, by which the silver is obtained pure, and the muriate of soda sublimed. The auriferous silver ores may be treated with potash, by fusion in a crucible; the alloy of silver and gold is first obtained, and the two metals may be separated by the process of *parting*. These ores which consist of silver combined with antimony, or arsenic, or both,

are first roasted, to drive off the arsenic and antimony, the silver remaining pure. The process is much facilitated by the use of nitre, for the purpose of oxidating the metals to be dissipated. The ores of silver are reduced either by fusion or amalgamation; the former method is chiefly practised on native sulphuret of lead or galena, which commonly contains a portion of silver, and often in such quantity as to make its separation from the lead a profitable undertaking. After the lead has been extracted from the ore, the object of the refiner is to obtain the silver in a separate state, which is dispersed through the mass of lead; this is performed by the process of cupellation on a large scale, or refining, as it is usually termed. The other process of reducing silver ores by amalgamation is now pretty generally followed in different parts of Europe. The ores which are subjected to amalgamation are such as contain only a small quantity of lead or copper; but it is of some importance that there should be a certain proportion of iron pyrites; and if this proportion be not naturally mixed with the ore, it is a good practice to supply the deficiency by adding what is wanting to the dressed ore, so that the pyritical contents may, as nearly as possible, be in a certain proportion to the quantity of silver, which is to be ascertained by previously assaying a portion of the ore. The ore being reduced to the consistence of coarse sand, is carefully mixed with common salt, in the proportion of eight or nine per cent.; when the silver in the ore amounts to eight ounces per quintal, and when the latter amounts to thirty-two ounces, or even a greater proportion, from ten to twelve per cent. of salt is to be added. The next process is roasting the ore, in which about three quintals are spread on the floor of a reverberatory surface, and subjected to a moderate red heat. During the roasting, the ore is to be turned twice or thrice, that every part of it may be equally exposed to the heat. When the whole of the ore is roasted, it is ground in a mill and passed through sieves, by which it is made as fine as meal, and is then prepared for the proper process of amalgamation; this is performed in the following manner:—A number of small barrels, which are made to revolve rapidly on their axis by means of machinery; or fixed tubs, either open or covered, having in the centre of each an instrument resembling a chocolate mill, which may be turned rapidly by similar machinery; the tubs or barrels are filled about one-third with water, and, afterwards, a sufficient quantity of roasted ore and mercury, in nearly equal proportions, is introduced, so that the whole may be of the consistence of thin mud. The machinery is put in motion, and continued without interruption, for thirty or forty-eight hours, according to the nature of the ore, when the amalgamation is completed. About a quarter of an hour after the agitation of the matter in the barrels has ceased, the greater part of it falls to the bottom, and is withdrawn by opening a hole made for the purpose; the earthy residue is carefully washed by small portions at a time, and thus a good deal of the amalgam, which, from being very minutely divided, could not sink through and mix with the rest, is recovered. The earth, however, if originally rich in silver, still retains a small proportion; it is, therefore, dried, and being mixed with about three per cent. of salt, is again roasted, but at a higher temperature than at first; and the process of amalgamation being again repeated, the whole of the silver is extracted. The fluid amalgam is strained through a closely woven bag, and is thus separated into nearly pure mercury and a stiff amalgam; and the latter being subjected to distillation, the mercury is driven over, and the silver remains behind: the copper, which is combined with the silver, is separated by cupellation.

*Ores of Mercury.*—These present less variety than those of many other metals; and on account of the peculiar properties of the metal, the management of its ores, whether for the purposes of analysis or reduction, is less complicated and difficult. In order to analyse the ore of native mercury, or native amalgam, it may be dissolved in nitric acid. The gold, if any is present, remains in the state of powder, and may be estimated by its weight. The affusion of water precipitates the bismuth, if the solution happens to contain any. Common salt precipitates the silver, and also part of the mercury, but the latter may be redissolved by a sufficient quantity of water, or, which is far better, of oxymuriatic acid, while the muriate of silver remains insoluble; lastly, the mercury may be

precipitated by sulphate of iron, and estimated. Native cinnabar may be treated with a mixture of three parts muriatic, and one part nitric acid, which dissolves the mercury, and leaves the sulphur. Muriate of mercury may be digested in muriatic acid, till the whole is dissolved. Muriate of barytes precipitates the sulphuric acid, 100 parts of which are equivalent to 186 of sulphate of mercury, and the proportion of this salt being known, we have that of the muriate. A very simple process is followed for reducing the ores of mercury; the best and most scientific method is that practised at the mines of Deaux Ponts and Poria. The ore, as it is brought out of the mine, is carefully sorted by the hand, and those parts which seem destitute of metal are rejected. It is next reduced to powder, and accurately mixed with one fifth of quicklime, which has fallen to powder by exposing it to the air, the quantity of quicklime being regulated by the proportions of cinnabar contained in the ore. The mixture being thus prepared, is introduced into iron retorts, which are capable of holding about sixty pounds weight. The retorts, to the number of forty or fifty, are fixed in a long furnace, and a glass receiver is attached to each, but it is not luted. A moderate heat is then applied, for the purpose of driving off the whole of the moisture, and when this is done, the joinings of the vessels must be closely stopped with tempered clay, and a full red heat is to be applied, and continued for seven or eight hours, at the end of which time the whole of the mercury will be volatilized, and condensed in the receiver. By this process, it is found that from six to ten ounces of metal are produced from one hundred pounds of the ore.

*Ores of Copper.*—This metal is found native in the state of oxide, in the state of sulphuret, and in that of salt, combined with carbonic, muriatic, phosphoric, and arsenic acids. Native copper sometimes contains gold, silver, or iron. It may be dissolved in nitric acid: the gold remains in the state of a blackish or rather violet-coloured powder; the silver may be separated by a polished plate of copper (or it may be precipitated from a separate portion of the solution by common salt); the iron may be separated by boiling the solution to dryness, and treating the residuum with water. By this process, the nitrate of iron is decomposed; the oxide of iron remains, while the water dissolves the nitrate of copper; this last salt may be decomposed by boiling it with potash; the precipitate dried in a red heat is black oxide of copper; one hundred parts of it denote eighty of the metallic copper. Sulphuret of copper may be dissolved in dilute nitric acid; part of the sulphur remains unaltered, and may be estimated by weighing it, and burning it off; part is acidified, and may be precipitated by nitrate of barytes, 100 parts of the dried precipitate indicating 14.5 of sulphur. By evaporation to dryness, and solution in water, the iron is separated, and the copper may be estimated as in the last paragraph, or muriatic acid may be used instead of nitric acid, but in that case it is more difficult to obtain a complete solution. The usual process employed in our Cornish mining districts, for reducing copper ores to the metallic state, are described under the article COPPER, (which see.)

*Ores of Iron.*—Notwithstanding the great variety of iron ores, they may be all, as far as analysis is concerned, arranged under three heads; namely, sulphurets, oxides, and salts. The first are distinguished by their general bronze colour, but more particularly by the suffocating smell of sulphureous acid gas, which they afford by being heated to redness in the open air. The second consist of iron united with oxygen, and are by far the most common of all. Nearly the whole of the iron ores in use are of this kind, containing also different proportions of earthy matter in their composition. The third division comprehends such as consist of the oxide of iron combined with some acid, and hence are called salts; the principal varieties of these are the phosphates, sulphates, arseniates, and carbonates. The various processes employed at our great iron works for the reduction of the different species of iron ore, are given under the article IRON.

*Ores of Tin.*—Tin-stone, or vein tin, as it is called in Cornwall, contains a large proportion of stony matters; it therefore requires considerable care in its preparation, previously to its being reduced. It is first broken by hammers into pieces about the size of a hen's egg, when it is ready for the operation of stamp-



ing, which is performed in the way already described for the ores of gold excepting that there are only three stampers. A tin plate of about a foot square, and pierced with holes, to admit a moderate sized knitting needle, is inserted in front of the trough, and that surface of the plate with the rough extremities of the holes is on the inside, by which the holes are prevented from being plugged up with the ore. As the ore is reduced to the proper fineness, it passes with the water through the holes into the labyrinth where it is collected, and after being washed on a wooden table, it is ready for roasting. In this state it has a considerable proportion of copper and iron pyrites, and is called black tin; after being calcined, at a low red heat, for several hours in a large reverberatory furnace, the ore comes out of a bright ochrey red colour, owing to the decomposition and oxidation of some of the metallic substances; but the oxide of tin, when the operation is properly conducted, remains unaltered. The ore is washed a second time, to separate the remaining impurities, and the water, which is impregnated with sulphate of copper, is retained, and decomposed by means of old iron. The reduction of the ore is the next step in the process; seven cwt. of roasted ore, with one fifth of its bulk of small coal, are introduced into a reverberatory furnace, which is about seven feet long, and three and a half wide—no lime, or, indeed, flux of any kind, is required. A brisk heat is kept up for about six hours, the tin sinking down as it is reduced, and covered with black scorixæ. The furnace is now tapped, and the metal flows into a shallow pit; when the whole of the metal has run out, the scorixæ are removed from the furnace, and a fresh charge is made. The metal in the pit throws up a slag, rich in metal, which is immediately returned into the furnace, and after the melted tin has cooled a little, it is taken out with ladles, and poured into granite moulds; each charge affords on an average from four to five cwt. of metal, but as the first scorixæ are not entirely free from metal, they are again stamped and washed, and mixed with a new parcel of roasted ore. The pigs of tin are next put into a small reverberatory furnace, where, without any addition, they are subjected to a very gentle heat; the purest part of the tin melts first, and is drawn off, forming what is called common grained tin; the other part contains some copper, arsenic, and iron, which is brought to a state of fusion, and cast into pigs, forming common tin.

*Ores of Lead.*—The methods of reducing lead ores have been given under the article LEAD. See also SEPARATION.

*Ores of Bismuth.*—Bismuth is accompanied by native silver, galena, some other metals, and earthy substances. In conducting the analysis, previous roasting is not requisite. The low degree of heat at which bismuth is fusible renders the reduction of the ores of this metal a very simple process. In the large way, the ores were formerly reduced merely by heating them along with burning fuel; sometimes a shallow hole was made in the ground, and filled loosely with pieces of wood and bushes, and after the fire was kindled, the ore, reduced to small pieces, was thrown in; sometimes the stump of a hollow pine tree was filled with wood and ore alternately, and set on fire, the bismuth separated from its matrix, and collected in a mass at the bottom; the scarcity of wood has, however, put an end to these rude and extravagant methods, and the ores of bismuth are now reduced in a common reverberatory furnace, the bed of which is lined with charcoal, whence the melted metal is removed in iron ladles, and cast into masses weighing twenty or thirty pounds, in which state it is brought to market.

*Ores of Zinc.*—The ores of zinc are the native carbonate, or common calamine, the oxide of zinc and blende, or the sulphuret of zinc. In the process for reducing the ore of zinc, it is first to be broken into small pieces, and the different impurities being separated, it is next calcined in a reverberatory furnace, at a moderate red heat; and if the ore be calamine, the carbonic acid is driven off, and if blende, it is deprived of its sulphur. After this it is washed, and the metallic oxide being separated from the earthy parts, it is dried, and carefully mixed with about one eighth of its weight of charcoal, by grinding the ingredients together in a mill, and is now ready for the smelting process. This is performed in a circular furnace, in which are fixed six large earthen pots,

about four feet high, and nearly in the shape of oil jars. An iron tube is inserted into the bottom of each pot, and passing through the arched floor of the furnace, terminates in a vessel of water placed beneath, while the other end of the tube rises within the crucible to a few inches of the top. The crucibles are then filled with the mixture of the ore and charcoal, to the level of the tube; the cover of each is carefully luted on, and an intense heat is to be kept for several hours. The zinc, as the process of reduction goes on, rises, in the form of vapour, to the top of the pot, but as it cannot escape, it descends through the iron tube, passes into the water, and is condensed in small drops. The globules are afterwards fused, and cast into the form of ingots, when it is fit for the market; but as common zinc contains a little of other metals, as copper, lead, arsenic, iron, and manganese, which impair its quality, these impurities are partially separated by melting the zinc in a crucible, and stirring into it, with a stick or earthen rod, a mixture of sulphur and fat; by the latter, the zinc is preserved from oxidation, and the sulphur combines with the other metals, except the zinc, and, converting them into sulphurets, they rise to the top in the form of scorize, which may be removed. This process is to be repeated as long as any scorize appear. See ZINC.

*Ores of Antimony.*—The sulphuretted ore of antimony is the only one which is found in sufficient quantity to be employed in the process of reduction in the large way, and the process it undergoes is extremely simple. The ore, being separated from the greater part of the stony matters which adhere to it, is placed on the bed of a reverberatory furnace, and covered with charcoal powder, and being brought to a low red heat, the sulphuret enters into fusion, and the earthy parts, floating on the surface, are removed with a rake. The melted part is cast into the form of large cakes, and is the crude antimony of the shops. The metal is obtained in a state of purity from the crude antimony or sulphuret, by different processes. After its reduction to a pure state, it has been long known by the appellation of regulus of antimony. In the reformed chemical nomenclature, indeed, it is now called simply antimony, but the term regulus still continues to be used by the merchant or the artisan. (See ANTIMONY.) The ores of Cobalt, Nickel, Arsenic, Titanium, and Manganese, are noticed under their metallic heads.

ORGAN. A large and very harmonious musical instrument, of considerable antiquity. They were first introduced into this country about the fourteenth century, although instruments of a similar nature, but of a less refined construction, were in use long prior in some of the cities of the southern and western parts of Europe. During the civil wars they were removed from the churches in England, and so generally reprobated that there could scarcely be found either organists or organ-builders; but after the Restoration, owing to the deficiency of workmen and musicians, liberal encouragement was offered for the introduction of foreign talent, and the re-establishment, at home, of our native emigrants. The most conspicuous of those who, in consequence, came over to minister to the public taste, were Bernard Schmidt (afterwards distinguished by the name of Father Smith) and Renatus Harris; and, it appears, these two individuals were so nearly matched in ability, that several public trials were made to determine whose instrument was entitled to superior estimation, which was finally adjudged to Father Smith. In the *Universal Magazine* for 1778, a quaint account is given of this controversy from the pen of an anonymous correspondent. This occurred during the reign of Charles II.; and of the organs that were constructed at that period by Harris, several fine ones are said to be remaining in London; namely, that of St. Bride, St. Lawrence, and St. Mary Axe. Of those constructed by Father Smith, may be enumerated that for St. Paul's, St. Mary Woolnoth, the Temple Church (where the contest took place), St. Mary, Oxford, and Trinity College, Cambridge; all of which have been highly celebrated for their tone and the variety of their powers, embracing the vox humana stop, the cremona, the flute, and many others. It is, indeed, considered by many reputed judges, that these old instruments far surpass in tone any of more modern construction notwithstanding the great improve-

ments in the mechanism of organs by Byfield, Snetzler, Green, Gray, Flight, and others.

The modern organ is a very complicated and ingenious piece of mechanism. Although it is spoken of as one instrument, yet, strictly speaking, it is a collection of instruments, all brought under the fingers of one performer; and so contrived, that he has it in his power to play on any one singly, or to combine several, or all, according to his taste, in order to produce variety of effect: it consists, even in its simplest form, of a number of sets of pipes, each producing the twelve notes of the chromatic scale, and comprising several octaves, according to the usual key-board. The magnitude and grandeur of these instruments chiefly depend on the number and variety of the stops and sizes of the pipes, so that the difference of effect which it is in the power of an able organist to produce is almost endless. To give a particular detail of the construction of organs, would scarcely accord with our prescribed limits, and would, in a great measure, be a repetition of many of the parts described under the head of *AROLLONICON*; we shall, therefore, close the subject in this place, by referring the reader to our account of the latter instrument, and to the article *ORGAN*, in the *Oxford Encyclopædia*, which contains much interesting information on this subject, with several engravings, explanatory of the mechanism of the several kinds of organs.

**ORPIMENT.** A mineral substance, consisting of arsenic combined with about forty-three parts of sulphur, and is about thrice as heavy as water. It is found, both in a massive and crystallized state, in Turkey, Hungary, and some other countries. The orpiment of commerce is an artificial production, chiefly imported from different parts of the Levant. A beautiful, but fugitive pigment, called *king's yellow*, is prepared from this mineral. (See *PAINTING*.)

**ORRERY.** An astronomical instrument, for exhibiting the motions of the heavenly bodies, was first constructed by Graham; but its name is derived from one made by Howley for the Earl of Orrery. It is now generally called *PLANETARIUM*, (which see.)

**ORRIS-ROOT.** The root of a white-flowered kind of iris, called *Florentine Iris*, which is a native of Italy, and is distinguished by having two flowers on each stalk; the petals bearded, and the leaves sword-shaped. In a dried state, this root is well known on account of its grateful odour, which somewhat approaches that of the violet. It is consequently much used in the manufacture of hair-powder, and other articles, for which an agreeable scent is required. It is sometimes employed in medicine as a pectoral or expectorant, and sometimes in dropsies. In a recent state, the root is extremely acrid; and, when chewed, excites in the mouth a pungent taste, which continues for several hours; but this acrimony is almost wholly dissipated by drying. Orris-root is chiefly imported into this country from Leghorn.

**OSCILLATION, Centre of.** That point, in a body vibrating by its gravity, in which, if any body be placed, or if the whole mass be collected, it will perform its vibrations in the same time, and with the same angular velocity, as the whole body, about the same point or axis of suspension. The centre of oscillation may be thus found: suspend the body by the given point, so that it may vibrate freely in small arcs, and count the number of vibrations it makes in a minute; then will the distance in inches, of the centre of oscillation, be equal to the number 140,850, divided by the square of the number of vibrations. Thus, suppose any irregular body were set in vibration, and made 30 vibrations in a minute, then  $\frac{140850}{30^2} = 156\frac{1}{2}$  inches. The number 140,850 is obtained by multiplying 39 $\frac{1}{2}$  inches, the length of a seconds pendulum, by the square of 60, the number of vibrations it makes in a minute.

**OSMIUM.** A metal lately discovered by Mr. Tennant among platina, and thus called by him, from the pungent and peculiar smell of its oxide. The pure metal, previously heated, did not appear to be acted upon by acids. Heated in a silver cup, with caustic alkali, it combined with it, and gave a yellow solution similar to that from which it was procured. From this solution, acids separate the oxide of osmium.

**OVEN** is a general term applied to variously formed apparatus employed for

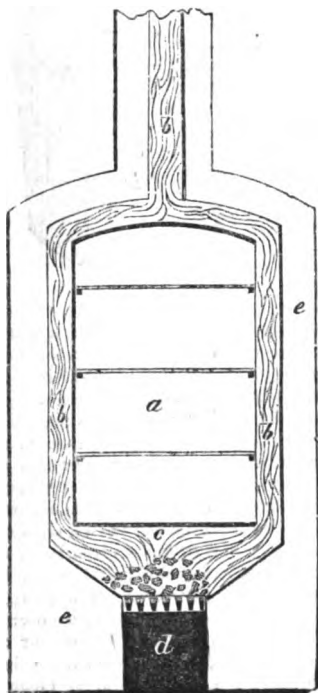
baking or drying different substances, many of which have been described in the course of this work ; we shall therefore confine ourselves, in this place, to an account of that particular class of ovens which are used for the baking of bread. The common baker's oven, "upon the old principle" (as it is now distinguished), is usually a vaulted chamber of brickwork, of an oval shape, and having an iron door and frame in front ; and there is mostly added in the upper part an enclosed closet with an iron grating, for the "tins" to stand on, called the proving oven. To heat these ovens, faggots are usually employed ; these are put inside, and burnt to ashes, which are afterwards removed, and the bottom cleared out. During this process a great deal of the heat escapes ; and as a still farther length of time is required to charge the oven with the bread, the oven must necessarily be made much hotter at first than is required for the baking temperature ; and, consequently, a great waste of fuel is the consequence. If this heat be not greatly in excess at first, the oven gets chilled before all the bread is put in, and causes the latter to sink and become "heavy." To remedy this inconvenience, ovens of more recent construction are built upon a solid base of brickwork, with a door of iron in front ; and on one side of this is another iron door, opening into a small furnace, provided with a grating, on which the fuel (coal) is laid, and an ash-hole underneath. The fire-chamber is separated from the oven by means of a partition, but is open at the end : over this is usually erected a copper with a cock to it, for heating and supplying water to the bakehouse ; and on one side of the copper is situated the proving oven, also inclosed in the brickwork. In heating the oven, the draught from the fireplace causes the flames and heated gases to sweep and reverberate around the circular walls and dome ; and the soot that may be at first deposited upon the brickwork is subsequently burnt off, as the fire burns clear, or is brushed away before the bread is put in by a swab, such as is used for cleansing the decks of ships at sea. The farthest extremity of the fire-chamber is usually provided with a sliding door, by the opening or closing of which the heat may be regulated ; and thus, as well as from the proximity of the fire and chamber, the heat of the oven may be kept up during the time the bread is being put in.

An oven, invented by Count Romford, and termed the perpetual oven, has been much extolled ; and though we have never seen it in use, it deserves, from its originality, ingenuity, and convenience, to be better known. For the baking of small bread, pastry, and the like, its utility is manifest. The following is the description given of it by the Count, with the manner of using it :—"In the centre of a circular, or rather a cylindrical mass of brickwork, about eight feet in diameter, which occupies the middle of a large room on the ground floor, I constructed a small circular closed fireplace for burning either wood, coals, turf, or peat ; the diameter of the fireplace is about 11 inches, the grate being placed about 10 inches above the floor, and the top of the fireplace contracted to about 4 inches ; immediately above this narrow throat, six separate canals (each furnished with a damper, by means of which its opening can be contracted more or less, or entirely closed,) go off horizontally, by which the flame is conducted into six separate sets of flues, under six large plates of cast-iron, which formed the bottom of six ovens on the same level, and joining each other by their sides, which are concealed in the cylindrical mass of brickwork. Each of these plates of cast-iron being in the form of an equilateral triangle, they unite in the centre of the cylindrical mass of brickwork ; consequently, the two sides of each unite in a point at the bottom of it, forming an angle of sixty degrees. The flame, after circulating under the bottoms of these ovens, rises up in two canals, concealed in the front wall of each oven, and situated on the right and left of its mouth ; and, after circulating again in similar flues on the upper flat surface of another triangular plate of cast-iron, which forms the top of the oven, goes off upwards, by a canal furnished with a damper into a hollow place, situated on the top of the cylindrical mass of brickwork, from which it passes off in an horizontal iron tube, about 7 inches in diameter, suspended near the ceiling of the room, into a chimney, situated on one side of the room. These six ovens, which are contiguous to each other in this mass of brickwork, are

united by their sides by walls made of tiles, about an inch and a half thick, and ten inches square, placed edgewise, having its separate canals furnished with a register communicating with the fire-place. Any one, or more of them, may be heated at the same time without heating the others; or the heat may be turned off from one of them to another, in continual succession; and, by managing matters properly, the process of baking may be uninterrupted. As soon as the meat-pies, or puddings, are drawn out of one oven, the fire may be immediately turned under it to heat it again, while that from under which the fire is taken is filled with other dishes, and closed up." We have heard of several ovens having been erected, of which this plan of Count Rumford forms the groundwork.

*Hicks's economical Oven.*—In the year 1830 a patent was taken out by Mr. Robert Hicks for "an economical apparatus or machine to be applied in the process of baking for the purpose of saving materials;" and for carrying this invention into effect on the great scale, the Metropolitan Bread Company (now extinct) was established. The saving of materials mentioned in the title just quoted, had reference to the saving of the vinous spirit which is generated by the fermentation of the dough, and is given off chiefly in the process of baking. This spirit, when duly rectified, is pure alcohol, and the quantity thus obtained from bread has been variously stated; but we believe it amounts to nearly a gallon per sack of flour when the oven is perfect, and the joints well luted. To make a chamber or retort so impervious as to carry on the process of distillation as well as that of baking, would, of course, be impracticable with such porous and friable materials as brick and stone; Mr. Hicks, therefore, adopted one of iron, laying inside upon the bottom a floor of bricks, that too scorching a heat might not be communicated from the metal to the bread; a fire is made under the oven, at a proper distance, and brick flues communicating with the fire chamber, are carried around the outside of the oven, so as to envelope every part. The door of the oven is made to fit it accurately by grinding, and is brought into close contact by a transverse bar and screw, in the manner of closing the mouths of retorts. In the centre of the top of the oven a large tube, or neck, is fixed vertically, extending from the brickwork which covers the iron chamber; in this tube the vapours from the bread are collected, and are thence conducted by a lateral pipe into a common distiller's worm, which, being surrounded by cold water, the vapours become condensed, and the resulting liquid, composed chiefly of water and alcohol, in the state of "low wines," is drawn off into suitable receptacles for subsequent rectification. In order to regulate the temperature of the oven, an iron tube, about the size of a musket barrel, and about a foot long, and closed at the lower end, is suspended vertically in the middle of the neck by passing it through a conical hole in the latter, to which it is closely fitted: in this tube oil is deposited, and into the oil is suspended the bulb of a thermometer, whose graduated scale above exhibits the temperature of the oil, and, consequently, very nearly that of the oven. To equalize the application of heat to the oven, Mr. Hicks adopted the revolving fireplace of Steel and Brunton. For this purpose the oven is made circular, and at about a foot from the bottom of it is a large circular plate of the same diameter as the oven (six feet), which turns in a horizontal plane on a vertical axis, forming a complete partition between the fire-place and the ash-pit, except where the fire-grate is situated, which is made of a sectorial form, and, consequently, readily admits of being shifted into or out of its place; and, in order that the air which is admitted into the ash-pit to promote the combustion of the fuel may not be diverted from its proper course, the rim of the circular plate is provided with a descending rim, which dips into an annular channel filled with water, forming what is called an hydraulic joint. Mr. Hicks states in his specification, that when the thermometer before-mentioned indicated a temperature of 280° Fahr., the oven is at a proper heat for baking, and that, during the process, a heat from 280° to 310° should be maintained; and we know that at this temperature bread may be perfectly baked. Notwithstanding this circumstance, we have proved, experimentally, that the heat of ordinary baker's ovens is usually not less than 800° Fahr. at the time the first bread is

put in; but the rapidly cooling influences it is afterwards subjected to, probably renders such a high temperature necessary at the commencement of baking by the ordinary process; this apparently entails such a wasteful expenditure of fuel, that it is well deserving of investigation which of the two modes of baking, that of a great heat at the commencement only, or that of a moderate heat continued throughout the process, is the best. It has been held, that the latter has the advantage of rendering the bread sweeter, by the vapour carrying off matters that are both unsavoury and prejudicial; while the former, from the vapour being *retained* in the oven, infects the bread. But this opinion can have but a slight basis to rest upon; a little reflection will show us that in Hicks's oven, as in others of the same class, the vapour *must* pass off somehow, otherwise it would become dense, and acquire so much expansive force, at a temperature of  $300^{\circ}$ , as to burst open the oven. The elasticity of the vapour in it, like that of a common still, can, therefore, but little exceed the pressure of the atmosphere; but this weak steam is highly heated by radiation from the top, sides, and bottom of the oven, and thus the baking is effected. Now, if we consider the mean heat of a common baker's oven to be  $450^{\circ}$  (and we know it is not less), it is quite obvious that dense steam at a such temperature could not exist in a structure of the kind; nor, indeed, at a heat much above  $212^{\circ}$ . And as  $212^{\circ}$  is much below a baking temperature, by far the greater part of the vaporized water must escape, in the form of steam, through some chinks or fissures in the brickwork or door; for if it did not, the density of the steam would, infallibly, soon blow open the oven. The baking is, in this case, as in the former, effected by means of weak steam, surcharged with heat, by radiation from the top of the oven, which must necessarily receive a higher temperature, because it has, from its arched form, to operate at a greater distance from the bread, and has to suffer a continual abstraction without any fresh supply; hence arises the question, whether the loss of caloric, radiating from the arched top of the common brick oven, is greater in amount than, that which escapes unused by continuous heating at a lower temperature. There are, however, other considerations which should enter into the inquiry, which we have not space to pursue farther, but must proceed to the next subject that presents itself to our attention. This is a domestic oven, which, we are informed, has been brought successfully into use in several families. The annexed figure gives a sectional view, the front of the oven being supposed to be removed to show the interior construction. *a* is the oven; *bb* the flue, which passes over the exterior surfaces of the sides, the back, and bottom of the oven; *c* is the furnace; *d* the ash-pit; *e* the brick-work enclosing the oven. It is not intended that anything should be placed on the bottom of the oven. The shelves are not formed of iron plates, but consist each of two oblong trivets of wrought iron, placed side by side, a little distance apart from each other. The oven is supported at the back by horizontal bars fixed in the brickwork at each corner. The front of the oven has three separate doors and frames; one larger one for the oven part, two smaller underneath for the furnace and the ash-pit.



Notwithstanding the commendation this oven has received, it appears to us to possess the common defect of the ordinary ovens attached to kitchen grates; that of communicating a scorching heat in one part of the bread, or other article, while the opposite side of it is comparatively cold. Skillful operators may, by turning the bread frequently, and carefully regulating the temperature, bake tolerably; but without some very active circulating intermedium, ordinary attention will not suffice to bake in a proper manner. How far these defects are obviated in a recent invention, denominated Hebert's Patent Domestic Oven, the reader will determine. The object of the inventor has been to provide a very cheap and durable apparatus, capable alike of baking bread properly, and cooking other kinds of food; they are made of various sizes, to adapt them to the wants of different individuals, and are rendered as portable as possible, to suit the requirements of the army and navy. We shall here add, by way of example, a description of the smallest size, which we saw in the warehouse of the agents, Messrs. Donaldson and Glasgow, of Birmingham.

*Fig. 1* exhibits an external view of the whole apparatus; the outside vessel *b* being simply a well-made cast-iron boiler, or pot, which, when used alone,

Fig. 1.

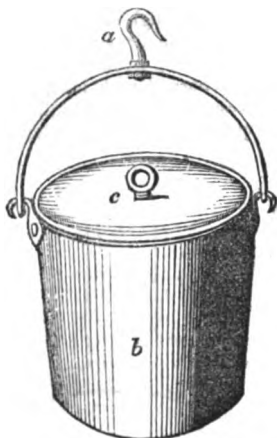


Fig. 2.



Fig. 3.



(that is, without the internal apparatus described underneath,) is applicable to all the various uses of other boilers,—but it possesses this further advantage, of having a strong double cased iron lid *c*, ground to fit so closely as to prevent the radiation of heat, and the escape of the rarefied steam, while it easily permits dense elastic vapour to pass off. The vessel is to be suspended over or in front of a fire, and in the case of the larger sizes, they may be conveniently set in brickwork, after the manner of common boilers.

For the purpose of baking bread or pastry, the roasting of meat, steaming of potatoes and other vegetables, &c., there is placed inside the pot delineated in *Fig. 1* a perforated vessel, shown in *Fig. 2*. This vessel is made of smooth cast-iron, and drilled with holes at the side and bottom; and by means of little projecting studs, it is held steadily in the middle of the outer vessel, so as to leave a free space of about a quarter of an inch between both; around which space there is constant circulation of extremely hot vapour, which operates upon every part of the bread or other material placed therein. To receive the latter, there is a movable bottom, shown separately in the adjoining *Fig. 3*, which is removable at pleasure; but it serves to correct the tendency of too much heat in this part, when the oven is suspended over a strong fire.

it facilitates the discharge of the contents of the oven, and is easily kept perfectly clean.

Inside of *Fig. 2* there is also placed occasionally a connected series of shelves, or pans *dd*, which may either consist of two, as represented in the annexed *Fig. 4*, or of a greater number in the larger sizes. These are for the purpose of baking small bread, rolls, biscuits, tarts, &c.—the roasting of potatoes, for frying or stewing meat, &c.—which may easily be withdrawn from the oven by means of the bail handle *e*, which is jointed so as to fall down on either side.

A fifth appendage, for roasting meat, is also supplied. It consists, as represented in *Fig. 5*, of a circular dripping pan *f*, having an upright spit *g* in the centre, and a jointed bail handle for putting it in or taking it out of the oven. The pan serves equally well for broiling, frying, and other processes, which every cook will comprehend without explanation.

The patentee states, that, by the application of the several parts of this apparatus, either in their single state, or combined in the various ways explained, bread and all other kinds of food may be *baked, roasted, boiled, stewed, or fried*, with the utmost facility and economy; the instructions for which are sent out with each of the ovens.

**OXALIC ACID.** This acid, which abounds in wood sorrel, and which, combined with a small portion of potash, as it exists in that plant, has been sold under the name of *salt of lemon*, to be used as a substitute for the use of that fruit, particularly for discharging ink-spots and iron-moulds, was long supposed to be analogous to that of tartar. The oxalic acid is a good test for detecting lime, which it separates from all the other acids, unless they are present in excess. It has, likewise, a greater affinity for lime than for any of the other bases, and forms with it a pulverulent insoluble salt, not decomposable except by fire, and turning syrup of violets green. Some fatal accidents have occurred from persons mistaking this salt for Epsom salts; two or three drachms of the oxalic acid acting as a violent poison.

**OXIDATION.** The process of converting metals or other substances into oxides, by uniting them with a certain proportion of oxygen.

**OXIDES.** Substances combined with oxygen without being in the state of an acid. There are several oxides of the same substances, differing in the proportion of oxygen they contain. When a substance combines with only one proportion of oxygen, it is termed the protoxide: with two proportions of oxygen, it forms the deutoxide or binoxide; with three, the tritoxide or teroxide; and with four, the peroxide.

**OXYGEN**, which, uncombined, is known only as a gaseous substance, was discovered by Dr. Priestley, in 1774. It has been called dephlogisticated air, empyreal air, and vital air. The term oxygen was given on the supposition that it was the sole cause of acidity. This substance is highly important in the economy of nature, as it forms about a fifth part of our atmosphere, and is abundantly contained in water, acids, salts, and oxides.

Oxygen gas may be obtained from a variety of sources. The peroxide of manganese, of lead and mercury, also nitre and chlorate of potash, yield large quantities when exposed to a red heat. The substances most commonly employed to procure it, are nitre, peroxide of manganese, and chlorate of potash. If nitrate of potash be exposed to a red heat in a coated glass or earthen retort, or in a gun barrel, a quantity of oxygen gas, (about 1200 cubic inches from a pound of nitre,) will be given off, but this is liable, particularly towards the end of the process, to be contaminated with nitrogen. From the peroxide of manganese, the gas may be obtained either by heating the substance red hot in a

Fig. 4.

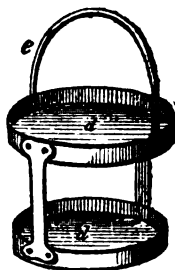


Fig. 5.





gun barrel, or by putting it in the state of a fine powder into a flask, with about an equal weight of concentrated sulphuric acid, and heating the mixture by means of a lamp. In the dry way, one ounce of peroxide of manganese should yield about 128 cubic inches of oxygen. The gas procured in this way is sufficiently good for ordinary purposes, but when required of great purity, it is better obtained from chlorate of potash. For this purpose the salt is to be put into a green glass retort, and heated to redness. It first liquefies, and then on increase of heat, is wholly resolved into pure oxygen gas, which escapes with effervescence, and into a white compound called chloride of potassium, which is left in the retort.

Oxygen gas is a little heavier than atmospheric air. Its specific gravity is 1.111; one hundred cubic inches weighing 34.454 grains. It is sparingly absorbed by water, 100 cubic inches dissolving only 3 or 4 of the gas; but under great pressure it may be made to take up half its bulk. It has neither acid nor alkaline properties, for it does not change the colour of vegetable blues, nor does it evince any tendency to unite with acids or alkalies. It has neither smell nor taste. It refracts light feebly, and is a non-conductor of electricity. It is the most perfect negative electric we possess, always appearing at the positive pole when any compound containing it is submitted to galvanism. It is essential to the support of animal life: an animal will live in it a considerable time longer than in atmospheric air; but its respiration becomes hurried and laborious before the gas is consumed, and it dies, though another animal of the same kind can sustain life for a certain time in the residuary air. When suddenly compressed, it has been seen to emit light and heat, but this is said to arise from the combustion of the oil with which the tube is lubricated. It has a very powerful attraction for most simple substances, and there is not one of them with which it may not be made to combine. Any inflammable substance previously kindled and introduced into it, burns rapidly and vividly. If an iron or copper wire be introduced into a bottle of oxygen gas, with a bit of lighted touchwood or charcoal at the end, it will burn with a bright light, and throw out a number of sparks. The bottom of the bottle should be covered with sand, that the sparks may not crack it. If the wire, coiled up in a spiral, like a corkscrew, as it usually is in this experiment, be moved with a jerk at the instant a melted globule is about to fall, so as to throw it against the side of the glass, it will melt its way through in an instant, or if the jerk be less violent, lodge itself in the substance of the glass. If it be performed in a bell glass, set in a plate filled with water, the globules will frequently fuse the vitreous glazing of the plate, and unite with it so as not to be separable without detaching the glaze, though it may have passed through, perhaps, two inches of water.

All substances that are capable of burning in the open air burn with far greater brilliancy in oxygen gas. A piece of wood, on which the least spark of light is visible, bursts into flame the moment it is put into a jar of oxygen; lighted charcoal emits beautiful scintillations; and phosphorus burns with so powerful a light, that the eye cannot bear its impression. The act of combining with oxygen is called oxidation, and bodies which have united with it are said to be oxidized. The compounds so formed, are divided into acids and oxides. The former includes those compounds which possess the general properties of acids, and the latter comprehend those which not only want that character, but of which many are highly alkaline, and yield salts by uniting with acids. Oxidation is sometimes produced with great rapidity, and with evolution of heat and light. Ordinary combustion is nothing more than a rapid oxidation, and all inflammable or combustible substances derive their power of burning in the open air from their affinity for oxygen. On other occasions it takes place slowly, and without any appearance of heat and light, as is exemplified by the rusting of iron when exposed to a moist atmosphere.

**OXYGENATION.** Similar in meaning to oxidation, but of more general application. It signifies the uniting of oxygen to various substances, whether the result be an oxide acid, or alkali.

**OXYMEL.** A compound of honey and vinegar.

## P.

**PAINTING, HOUSE.** The art of covering with various suitable pigments the wood-work, plaster walls and ceilings, iron work, &c., of the interior and exterior of houses. It may be divided into three separate branches, viz.—plain painting, graining, and ornamental painting.

The material chiefly employed in plain painting is white lead. It is a carbonate of lead produced by the action of the vapour of vinegar on sheet lead; and, when ground up with linseed oil, forms the common white lead paint of commerce. See **CRUZE**. It is improved by being kept for several years. To produce the different tints, various colours are added to the white lead base, in quantity according to the intensity of the tint desired, amounting, sometimes, to an exclusion of the white lead in the upper or finishing coats. The following are the colours generally used by the house painter:—

*White.*

White lead.  
Nottingham white.  
Flake white.

*Black.*

Ivory black.  
Lamp black.  
Blue black.  
Patent black.

*Yellows.*

Chrome yellow.  
King's yellow.  
Naples yellow.  
Yellow ochre.  
Raw sienna.  
Yellow lake.

*Browns.*

Burnt umber.  
Raw umber.  
Vandyke brown.  
Purple brown.

Spanish brown.  
York brown.

*Reds.*

Vermilion.  
Scarlet lake.  
Crimson lake.  
Indian red.  
Venetian red.  
Red lead.  
Orange lead.  
Burnt ochre.  
Burnt sienna.

*Greens.*

Brunswick green.  
Emerald green.  
Verdigris.

*Blues.*

Prussian blue.  
Indigo.  
Cobalt.  
Ultramarine.

To bring these colours to a state fit for use, they are ground up with a small quantity of oil; but for painting in distemper, the colours must be ground up in water. Linseed oil is that which is in general use, and is quite sufficient for the purpose of the plain painter, especially when improved by being kept for several years, as it then loses a great part of its colour. It is obtained by pressure from the seed of flax. In very rare instances, where the least yellowness in the oil would be injurious, nut or poppy oil may be used with advantage.

Spirits of turpentine is largely employed in painting; it is obtained by distillation from crude turpentine, which is procured from the larch and fir-trees: being of a volatile nature, it is used by the painter to produce what is called a flat; it evaporates, and leaves the paint without the least shine. It is also employed in those situations where oil would not dry, as in the first coat on old work, which is likely to be a little greasy from smoke, &c.

To hasten the drying of paints, *dryers* are generally used. Those most in use are sugar of lead, litharge, and white copperas. These, when well ground, and

mixed in small portions with paint, very much assist them in drying; indeed, some colours will not dry without them. Red lead is also an excellent dryer; and in cases where its colour is not objectionable, is much used. Sugar of lead is, however, the best dryer, though somewhat more expensive than the others. It should be observed, that, in the finishing coats of delicate colours, dryers are generally avoided, as they have a slight tendency to injure the colour. Linseed oil has sometimes a drying quality given to it by boiling with drying substances, which renders it extremely useful on some occasions. A very good drying oil is made by boiling one gallon of linseed oil with a quarter of a pound of litharge, or red lead, reduced to a fine powder. It must be kept slightly boiling for about two hours, or until it ceases to throw up any acum; when cold, the clear oil must be poured off, and kept for use.

The tools and apparatus employed by the plain painter are not very numerous; we shall mention the principal of them. The first in order is the grindstone and muller. This is an apparatus necessary to every painter, as the purity of the colours sold ready ground at the shops is not to be depended upon; and some colours, as lakes and Prussian blue, will not keep long after grinding. The grindstone is a slab of porphyry marble or granite, about two feet square; the chief requisite is, that it be hard, and close-grained.

The muller is a hard and conical-formed stone, the diameter of the base or rubbing surface of which should be about one-sixth of that of the grindstone, and the cone high enough to get a sufficient hold of it with the hands. The face of both grindstones and muller should be perfectly flat and smooth. A large palette knife is used to gather the colour from the stone as soon as it is sufficiently ground.

The palette is a small thin board, of an oval shape, having a hole in it for the thumb to pass through; it is used chiefly in ornamental painting, and for mixing up small portions of colour on. With this is employed the palette knife, for mixing up colours on the palette: it has a long, thin, and elastic blade, rounded at the extremity.

The most important of the painter's tools are the brushes: these are of all sizes, both round and flat, and are made chiefly of hog's-hair. The large round brush called the pound brush, and a smaller one called the tool, are those mostly used in plain work. The smallest hog's-hair brushes are called fitches, and are used for putting in small work where the tool would be too large. The pound brush is used as a duster for some time previous to putting it into colour, whereby it is rendered much softer. The smallest brushes are the camel-hair pencils, with long or short hair, according to the work to be done. The variety of brushes used in graining will be spoken of when we come to that division of the subject.

The stopping-knife has a shorter blade than the palette-knife, and is pointed. It is used for making good the holes and cracks with putty.

Putty is made of common whiting, pounded fine, and well kneaded with linseed oil, till it becomes about the consistence of stiff dough.

*Grinding colours.*—All substances employed for painting in oil require to be ground up with a small portion of the oil previous to mixing them with the whole quantity required for use; for this purpose, they must first be pounded, and passed through a tolerably fine sieve, then mixed with a portion of linseed oil, just sufficient to saturate them; a quantity, about the size of a small egg, is to be taken on the point of the palette-knife, and placed on the stone; the muller is then placed upon it, and moved round about, or to and fro in all directions, bearing a little weight on it at the same time. This should be continued until it is ground perfectly fine, having the consistence and smoothness of butter. The colour must be occasionally trimmed from the edges of the stone and muller with the palette-knife, and put under the muller in the middle of the stone. When sufficiently ground, it is removed from the stone with the palette-knife, and a fresh quantity taken. It is not well to have much colour on the stone at one time; it makes it more laborious, and will take a longer time to grind the same quantity equally well.

*Mixing colours for painting.*—Before the colours which have been ground can

be applied to the work, they must be rendered fluid by the addition of linseed oil, or spirits of turpentine, or certain proportions of both. When a tinted colour is required to be mixed up, a small quantity of the proper tint should be first prepared on the palette, which will serve as a guide to mix the whole quantity by. With the ground white lead there should first be well mixed a portion of oil, and then the tinting colour should be added, as ascertained by the pattern on the palette. When these are thoroughly mixed and matched to the proper tint, the remaining portion of the oil or turpentine is to be added; this is better than putting in all the oil at once: it should then be strained through a piece of fine canvass, or a fine sieve, and should be about the consistence of cream, or just so as to work easily. If it is too thick, the work will have an uneven, cloudy appearance, and it will be hard to spread; while, if it be too thin, it will be likely to run, or will require a greater number of coats to cover the ground, and render the work solid. The straining ought not to be neglected where the appearance of the work is studied.

*Preparing work for, and manner of proceeding with, the painting. New work.*—Clean the work, carefully removing all projections, such as glue, or whitening spots; this is easily done with the stopping knife and duster; then cover over the knots with a composition of red lead, called knotting. The red lead has the property of drying very hard; and if it was not used, the paint would not dry on the knots, and they would show through every coat. If the knots are very bad, they must be cut out. After knotting comes the priming, or first coat of paint. When the priming is quite dry, all nail-holes, cracks, and defects, are to be made good with putty; then proceed to the next coat, called the second colour; when this is dry, those places are to be stopped which were omitted in the last coat; and proceed according to the number of coats intended to be given. It should be observed that second colour for new work is made up chiefly with oil, as it best stops the suction of the wood; but second colour for old work is made up chiefly with turpentine, because oil colour would not dry or adhere to it so well. The colour should be spread on as evenly as possible; and to effect this, as soon as the whole, or a convenient quantity, is covered, the brush should be passed over it in a direction contrary to that in which it is finally to be laid off; this is called crossing: after crossing, it should be laid off softly and carefully, in a direction contrary to the crossing, but with the grain of the wood, taking care that none of the crossed brush marks be left visible. The criterion of good workmanship is, that the paint be laid evenly, and the brush marks be not observed. In laying off, the brush should be laid into that portion of the work already done, that the joining may not be perceived. Every coat should be perfectly dry, and all dust carefully removed, before the succeeding one is laid over it.

*Old work.*—Carefully remove all dirt and extraneous matter with the stopping knife and duster; those places near the eye should be rubbed with pumice-stone, and greasy places should be well rubbed with turpentine. Bring forward new patches and decayed parts with a coat of priming; stop and make good with putty, then proceed with the first coat, or second colour, in turpentine. The quality of the next coat will depend upon the manner in which it is to be finished. If it is to be painted twice in oil, and flatted, the next coat, or third colour, should be mixed up chiefly in oil, and tinted like the finishing colour, to form a ground for the flating. The greater the shine of the ground, the more dead will the finishing coat or flating be; likewise, the more dead the ground, the better will the finishing oil shine; therefore, it is a general rule that for finishing in oil the under coat should be turpentine, and for finishing flat, the under coat, or ground colour, should be oil; but observe, that all turpentine under coats have a little oil with them, and all oil under coats, except the priming or first coat on new work, have a little turpentine with them.

Knotting is made with red lead, carefully ground, and thinned with boiled oil and a little turpentine. For inside work, red lead, carefully ground in water, and mixed up with double size, is a good substitute, and is generally used: it must be used hot.

*Priming for new work.*—This is made of white lead with dryers, and a little

red lead to harden it, and further to assist its drying; it is thinned entirely with oil, and should be made very thin, as the new wood, or plaster, sucks it in very fast. It is a frequent practice with painters to save the oil coats by giving the new work a coat of size, or size and water, with a little whiting, called clearcole; but where durability is consulted, this should not be done. The size stops the suction of the wood or plaster, but, at the same time, it prevents the oil paint from adhering to the work; the consequence is, that it is apt to peel or chip off, especially in damp places. Clearcole is sometimes advantageously used on old greasy work, on which oil paint would not dry.

*Second colour for new work, or oil second colour.*—This is white lead thinned with oil and a little turpentine, with suitable dryers. The proportion of dryers for ordinary cases is about one ounce and a half to ten pounds of white lead; but in winter, or under other unfavourable circumstances, the quantity of dryers must be increased.

*Second colour for old work, or turpentine second colour.*—This is white lead thinned with about three parts of turpentine, and one of oil, also a little dryers. Where much turpentine is used, less dryers is required.

*Turpentine colour.*—This is only used when the work is to be finished in oil; that is, left shining. It is thinned almost entirely with turpentine, that the finishing coat may have a better gloss.

*Third, or ground colour,* is thinned with two-thirds oil and one-third turpentine, and tinted a shade darker than the finishing colour.

*Finishing oil colour* is thinned with a little more oil than turpentine, and tinted to the desired colour.

*Flatting, or finishing turpentine colour,* is thinned entirely with turpentine, and has no shine.

*A bastard flat* is thinned with turpentine and a little oil, which renders it more durable than the perfect flatting. To procure a good flat, it is necessary to have a perfectly even glossy ground, and it should be of the same tint, but a little darker than the finishing flat.

*For clearcole and finish.*—Stop defects with putty, clearcole, and finish with oil-finishing colour, as directed.

*For two coats in oil.*—Turpentine second colour, and finishing oil colour.

*For two coats in oil and flat.*—Turpentine second colour; third colour, and flat.

*For three coats in oil.*—Turpentine second colour; turpentine colour; and finishing oil colour.

*For three coats in oil and flat (old work).*—Turpentine second colour; turpentine colour; third, or ground colour; and flatting.

*For four coats in oil (new work).*—Oil priming; oil second colour; turpentine colour; and oil finishing colour.

*For four coats in oil and flat (new work).*—Oil priming; oil second colour; turpentine colour; third or ground colour; and flatting.

**TINTED COLOURS.**—*Stone colour.*—White lead, with a little burnt or raw umber, and yellow ochre.

*Gray stone colour.*—White lead, and a little black.

*Drab.*—White lead, with burnt umber and a little yellow ochre for a warm tint, and with raw umber and a little black for a green tint.

*Pearl colour, or pearl grey.*—White lead with black, and a little Prussian blue.

*Sky blue.*—White lead, with Prussian blue.

*French grey.*—White lead, with Prussian blue, and a little lake. These last, used in various proportions, will make purples and lilacs of all shades.

*Fawn colour.*—White lead, with stone ochre, and a little vermilion or burnt stone ochre.

*Buff.*—White lead and yellow ochre.

*Cream colour.*—Same as the last, with more white.

*Lemon colour.*—White lead, with chrome yellow.

*Orange colour.*—Orange lead, or chrome yellow and vermilion.

*Peach colour.*—White lead, with either vermilion, Indian red, purple brown, or burnt stone ochre.

*Gold colour.*—Chrome yellow, with a little vermilion and white.

*Violet colour.*—White lead, with vermilion, blue and black.

*Sage green.*—Prussian blue, raw umber, and yellow stone ochre, with a little white, and thinned with boiled oil and a little turpentine.

*Olive green.*—Raw umber, with Prussian blue, thinned as before.

*Pea green.*—White lead, with Brunswick green, or with Prussian blue and chrome yellow.

*Chocolate colour.*—Spanish brown, or Venetian red and black, thinned with boiled oil and a little turpentine.

*Lead colour.*—White lead and black.

*Plain opaque oak colour.*—White lead, with yellow ochre and burnt umber.

*Plain opaque mahogany colour.*—Purple brown, or Venetian red, with a little black.

Black should be ground in boiled oil, and thinned with boiled oil and a little turpentine.

It will be obvious that the proportions of the colours above mentioned must be determined by the particular tone of colour required.

*Distemping.*—The principal difference between oil and distemper painting is, that in the latter the colours are ground in water, and diluted with size. It is much less durable than oil painting, but is cheaper, and is not attended with much smell: it will not bear washing. Ceilings are generally distempered, and walls very frequently. There are several colours used for distemping that will not do for oil, as it would change them. The principal are,—common spruce ochre, common indigo, rose pink, brown pink, blue verditer, green verditer, mineral green, and Saxon green. Whiting is the substance mostly used in distemping. It should be broken and thrown into a vessel of clean water, and left to soak for a short time without stirring it—half an hour is sufficient; the surplus water is then poured off from the top, leaving only the softened whiting, which should then be stirred, to ascertain that there be no lumps in it. To this is added hot durable size, in the proportion of one pound of size to three pounds of whiting; it is then to be well stirred, and left to chill or congeal in a cool place. In summer weather it should stand over night, when, if it is like a weak jelly, it is fit for use. If it is to be a tinted colour, the colouring substance should be added to the whiting previous to the size being mixed with it. Distemper colours dry much lighter than they appear when first laid on; consequently, it is better, before mixing the size with them, to colour a slip of paper and dry it, to ascertain if it is of the desired tint. In distemping old walls or ceilings, it is necessary that the old distemper be first washed off with an old brush and plenty of water. The holes, cracks, and damaged places, should be made good with plaster of Paris, or distemper putty, made of powdered whiting and double size. They should then have a coat of clearcole made by adding a little more size and water to the finishing colour, and using it warm. When this is dry, the finishing colour may be laid on. For new walls, it is only necessary to clearcole and finish.

*Graining.*—Graining comprises the imitating of woods and marbles; the latter is distinguished by the term marbling: it is strictly an imitative art, and demands in its execution considerable judgment and good taste, united to a close observation of the peculiar characters of the different woods and marbles to be represented. It is usually done on ground prepared for the purpose, the colour of which is varied according to the kind of wood or marble to be imitated; but as the manner of proceeding in imitating woods differs from that in the case of marbles, they will be noticed separately, beginning with—

*Graining in imitation of woods.*—The first thing to be attended to is the ground; and, although generally laid on by the plain painter, it should receive the particular attention of the grainer, for on the colour of the ground greatly depends the excellence of the imitation. The ground should be chosen of the same colour, but a little lighter, than the lightest parts of the wood to be imitated, sufficient allowance being made for the varnish afterwards to come

upon it. Repeated trials on small patterns is, however, the best, and, indeed, the only safe way of arriving at the tint proper for the ground. The ground may either be mixed up, just as in finishing-oil colour, or it may be a bastard flat; and it should be very carefully prepared, as the shine of the varnish will cause the rough or uneven places to be detected. The pigments employed for graining are distinguished by the painter as transparent colours; those mostly used are raw umber, burnt umber, raw sienna, burnt sienna, Vandyke brown, burnt ochre, and lake; these, with the occasional assistance of small portions of the opaque, or imperfectly transparent colours,—ivory black, Prussian blue, or indigo, and purple brown, or Indian red, will be sufficient to match the colour of any of the woods usually imitated. These pigments were, until within these last few years, worked in oil and spirits of turpentine; but, in consequence of the much greater facility found to be afforded by the use of water or distemper colours, oil is now seldom or never used, except for wainscot or oak graining, which is frequently done in oil. The tools employed in graining are round and flattened hog-hair brushes, of various sizes; the round ones are used chiefly for laying on the colour. Occasionally, as in very large pieces of work, large brushes of any convenient form are employed for that purpose. Of the flat brushes, there are *cutters* of various sizes, from two and a half inches to half an inch wide; these are made of camel's hair, having the ends or points of the hairs cut off square, to within about three-eighths of an inch from the ferrule; the edges should be very sharp and straight: they are used for producing the mottled appearance, as in mahogany and satin-wood. *Flat hog-hair brushes*, of various sizes, from six, or even twelve inches, to one and a half inches wide; these are used chiefly for graining wainscot in distemper. Flat hog-hair brushes, but of a much thinner description than the last-mentioned, are used for putting on the second grain, and for other purposes. *Badger-hair tools, or softeners*, of several sizes; this tool is one of the most necessary kind, and it is employed to soften the work put in with the other tools. *Cross-banders*, of several sizes, from one and a half inch wide and upwards; they are flat hog-hair brushes, having their ends cut off to within about an inch of the ferrule; they should be very carefully made, and of the best hair; every bristle should lay straight and even, and, when cut, should have a straight, unbroken edge, similar to the cutter. We shall describe the use of this tool when speaking of the particular woods in which it is employed. These, with camel and hog-hair pencils, sponges, and pieces of wash-leather, are sufficient to imitate any of the woods except wainscot in oil, which requires a particular tool, which will be noticed presently. The woods generally imitated are the following:—oak, (dark oak,) wainscot, or light oak, pollard oak, mahogany, rose-wood, maple-wood, satin-wood, amboyna, zebra-wood, and yew. The general instructions given for imitating these will suffice for any other fancy woods. Wainscot, or light oak, although the most common, is perhaps the most difficult to produce a good imitation of: it is done either in oil or distemper. The manner of proceeding in oil will be first described.

*Wainscot in oil.*—The effect of the grain in this wood is produced by the horn graining-tool, which very much resembles a comb, but the teeth are not pointed. The teeth of the graining-tool are of equal dimensions from the root to the extremity, which is square, and the interstices between them are as small as they can be cut. The principal colour used is burnt umber; this, with a little touch of black and purple brown, makes an excellent wainscot colour,—or a little raw sienna may be used with it. This colour must be tempered with a peculiar vehicle called graining oil, which is made by dissolving two ounces of bees-wax in as much turpentine as will just cover it, and make it easy to dissolve, and by adding one pint of boiled oil, stirring it well while mixing. When it is cold it will be of the consistence of soft honey, and will, when to be used, require the addition of a little boiled oil and turpentine: a small quantity of colour is sufficient to stain a large quantity of oil. The graining colour is to be laid on very evenly and very bare. The brush marks, if not pounced out with the end of the brush or duster, must lie in the direction of the grain of the wood. The horn graining-tool is then to be passed over it, to imitate the grain; it

should be held in a slightly inclined position, and drawn along with a small waving motion, with a little pressure, passing twice over every part of the work. The veins are then to be put in, or rather wiped off, which is best done with a piece of cotton stocking, or wash leather, wrapped over the thumb nail. The veining is the most difficult part of it; and any directions that might be given, other than to observe nature closely, would be quite unavailing; nothing but a close observation of the peculiar character of the veins displayed in nature, with considerable practice, will enable any person to do it, even tolerably. As soon as it is dry, the dark shades observed in the wood are to be put in: for this purpose a little turpentine, stained with burnt umber, ground in oil, is sufficient; also the dark veins are sometimes put in with a hair pencil, and a little burnt umber and burnt ochre, diluted with turpentine. When quite dry, it may be varnished, and is then finished.

*Wainscot in distemper.*—Raw umber alone is a very good colour for this, or a little burnt umber may be added to it, to make a warmer tint. The fluid used for this and all other distemper graining must be such as will so bind on the colour, that the varnishing may not bring it off; small beer is the best, or, if it cannot be conveniently procured, stronger beer diluted with water may do, but there is nothing so good as stale, common table-beer. It is only necessary to mix the beer with the colour after it has been carefully ground in water, and it is then fit for use. Sometimes the colour will not lay on the ground; it is then said to ciss: this may be remedied by wetting the work all over with a sponge and water, and drying it with a wash-leather. Only so much should be begun at one time as can be finished before it gets dry, which it will do in a few minutes, according to the weather. The colour should be laid on as evenly and as quickly as possible, with a suitable brush, and then the flat hog's-hair brush must be drawn over it, in a straight line, and in the direction of the intended grain; this will leave it streaky: it is then to be carefully pounced or patted with the flat side of the same brush, making the head of the brush advance before the hand, and in the direction of the grain. This will make a very excellent imitation of the grain of oak, if it be well managed. The veins are to be wiped out with a piece of wet wash-leather, wrapped over the thumb nail. When this is dry, the shades may be strengthened by passing very lightly over it with weaker colour. Great care should be taken that it is quite dry before the varnish is laid on: it is not safe to varnish it in damp weather without fire being near it; but if it will bear the finger passing over it, it is dry enough.

*Pollard oak.*—Either burnt umber or Vandyke brown makes an excellent pollard oak colour. The colour, in this case, unlike wainscot, should be laid on unevenly, or darker in some places than in others, after the character of the wood; a coarse sponge, moistened, and assisted by the cutter, produces the effect very well. When the masses of colour are properly disposed with the sponge and cutter, it must be softened off with the badger-hair tool, and the knots put in with the end of a hog-hair fitch, by holding the handle between the thumb and fore-finger, and twisting it round; these knots may afterwards be assisted with a camel-hair pencil. A few small veins are frequently found in pollard oak; these may be wiped off in the same manner as for wainscot. When this is dry, the second or upper grain may be put on: this grain occurs in almost all the woods except oak and rose-wood; indeed, it is the proper grain of the wood, with the above exceptions. Some of the first colour diluted will do for this second grain. To put on this grain, the thin, flat hog-hair brush should be dipped into the colour, and the hairs must be combed out to straighten and separate them. As soon as the grain is put on, the softener should be passed lightly across the grain, in one direction only; this will make one edge of the grain soft and the other sharp, as it occurs in the wood. When the second grain is dry, it may be varnished.

All the other woods are done in a similar manner. The particular character and colour of the shades and grain of the wood must be carefully noticed, and those tools which will produce the effect most conveniently must be selected: for example, the thinnest flat hog's-hair brush will best produce the effect of



the grain in rose-wood ; the cutter will best produce the effect of the shades in mahogany and satin-wood ; the sponge and cutter in pollard oak. Plain mahogany may be very well imitated by properly disposing the shades with the common round tool, with which the colour is laid on, and then passing the badger-hair softener over it in a direction across the stripes. When this is dry, the second grain may be put on, as directed for pollard oak. Burnt umber and burnt sienna make a good mahogany colour.

*Marbling.*—Marbles are generally imitated with oil colours, and those colours are mostly opaque, as for this purpose it is not at all necessary that they be transparent. The manner of proceeding with the different marbles will not be detailed, but a few general instructions applicable to all of them will be given. The tools for imitating marble are less varied than those for imitating wood. A palette and palette knife, with numerous small sized hog-hair brushes and camel-hair pencils, and a duster, or worn badger-hair softener, are all that is necessary for imitating any of the marbles. The ground is to be chosen of that colour which is most predominant in the marble to be imitated ; for example, in black and gold marble, the ground is black ; in veined, it is white ; in sienna, it is cream colour ; and in dove marble, the ground is of a dark pearl colour. In proceeding to the imitation, the necessary colours are to be taken on the palette, and mixed up to match the tints in the marble to be imitated. In mixing, they must be slightly tempered with oil, and further tempered with turpentine for use ; and they should not be laid on thicker than is necessary to produce the proper effect. The softer shades are first to be put in, blending the different colours, as may be, in the marble. As soon as they are put in a proper form, they are to be softened by brushing lightly over with a clean duster, or old badger-hair softener ; but in some marbles there requires to be no softening : of course, when the shades or veins are sharp and hard, they must not be softened. The softer veins may be next put in, while the soft shades or ground-work is yet wet. As soon as this ground-work is dry, the shades may be heightened, and the strong and sharp veins put in. In putting in the soft shades or ground-work, care must be taken not to mix the colours together, so as to give the work a muddy appearance ; and the colours should be used as thin as will make the work sufficiently solid, or it will look uneven when varnished.

*Ornamental Painting.*—This chiefly consists in painting scrolls, figures, or other enrichments on plain work, so as to give them the appearance of relief or projection ; it is most commonly done in the corners and margins of panels. The ornaments or enrichments to be painted are usually sketched on paper, and the outlines are then pricked through with a needle point. This paper is to be laid on the wall or work on which the ornament is to be painted, and pounced over with a charcoal pounce-bag ; the charcoal dust, passing through the small holes in the paper, will leave a faint tracing of the outline of the ornament on the work, and serves as a guide to paint it by. The brushes used are camel or sable-hair pencils, with long hair ; and a rest-stick is held in the left hand, to steady the right hand by ; also a palette, to work the colour from, the same as is used by artists generally. If the colour of the ornament is to differ from that of the ground on which it is painted, the pounced outline should first be filled up, and, when that is dry, the shades put in ; but when the ornament is to be of the same colour as the ground, it will only be necessary to put in the shades, by the assistance of the pounced outline. As soon as the first shades are dry they may be heightened, and a stronger relief given to the ornament.

**PALETTE.** A small tablet, usually of ivory or wood, upon which painters lay small portions of the several pigments or tints they have occasion for in their work. Instead of a handle, it has a hole cut near the side, for the thumb of the left hand to pass through in holding it.

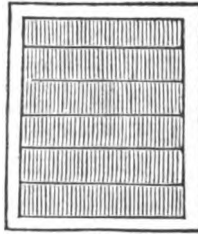
The term palette is also given by potters to the wooden instrument which they use to beat and shape out their work. Palette is a term also given to little levers employed in clock and watch work (see **HOROLOGY**) ; it is likewise applied to a variety of contrivances in mechanism, somewhat resembling in their action the little organ called by that name in the human mouth.

**PALETTE KNIFE.** A long knife with a very thin well-tempered steel blade, used by artists for mixing colours, or for rubbing down such as have been previously ground, on the palette. They are mounted in wood or ivory handles, according to the fancy of the user.

**PALLADIUM.** The name given to a metal discovered in 1803, by Sir H. Davy, associated with platina, among the grains of which he supposed the ore to exist, or an alloy of it, with irridium and osmium, scarcely distinguishable from the crude platina, though it is harder and heavier. The pure metal also very nearly resembles platina, and it takes as high a polish. It is ductile, very malleable, and, when reduced into thin plates, flexible, but not very elastic. It is harder and heavier than iron; its specific gravity is from 10.9 to 11.8.

**PAPER.** Thin leaves or sheets, fabricated of fibrous materials, and adapted to write or draw upon, as well as for numerous other purposes. Paper is an article of such immense importance in the commercial world, and of such general and extensive utility, that it will be well to give, in this place, a brief description of the several kinds manufactured in this country; for this purpose, we shall divide them into three classes, viz. :—Writing Papers, Printing Papers, and Wrapping or Packing Papers, with a short notice of several miscellaneous kinds, not included under either of these heads.

*Writing Papers* are a very numerous class, including all those that are used for writing or drawing purposes. Writing papers are called either *laid* or *wove*, according to the description of mould upon which they have been made. *Laid* papers are distinguished by their retaining the *wire-marks*, in long parallel lines, crossed at intervals by other stronger lines, as shown in the accompanying sketch. *Wove* papers, on the contrary, bear no impression of the wires, the mould used for their manufacture being made of very fine copper wire, woven in a manner similar to linen—whence the derivation of the term *wove*. Writing papers are made of two different colours, blue and yellow. The yellow cast is the natural colour of the rag, heightened as much as possible by skilful bleaching. The blue cast is obtained by adding smalt (the powder blue of commerce,) to the pulp, while in the vat. In all blue cast papers a considerable difference of colour exists between the two sides of a sheet, from the smalt, which is a heavy material, falling to the side of the sheet next to the mould: the under side, therefore, is always the bluest when the paper is finished.



*Laid* paper is mostly of the blue cast; *wove* papers are made of both kinds. Drawing papers, which are included in this class, are always made of the yellow cast, on *wove* moulds; and writing papers, (emphatically so called from demy upwards,) are always made of the blue cast, on *laid* moulds. In describing any of the numerous varieties of post, copy, foolscap, or pott papers, the distinguishing term, *laid*, *yellow-wove*, or *blue-wove*, is always necessary to be used; but in all papers from demy upwards, *wove* and *drawing*, or *laid* and *writing*, are synonymous terms; where no distinguishing term is used, *laid* is always understood to be meant. At the paper-mill, all kinds of paper are put up in certain parcels, called *reams*; a ream of paper consists of twenty quires, viz., eighteen quires of twenty-four perfect sheets, and two quires of twenty sheets each, defective paper, one of which is placed at the top, the other at the bottom of the ream, to preserve the perfect or inside paper from string-marks, and other injuries, to which, but for this precaution, it would be liable. If the two outside quires are replaced by two perfect quires, the ream is stated to be *all insides*, and the original value is increased five per cent. A printer's ream consists of twenty-one and a half unbroken quires, of twenty-four sheets each, and is called a *perfect ream*; the *perfecting*, as it is technically termed, increases the value one eighth.

The following comprehensive table gives the names, dimensions, and weight, per ream, of the several papers in this class.

*Writing and Drawing Papers.*

NAME.	DIMENSIONS.		WEIGHT. lbs.
	Inches.	Inches.	
Antiquarian . . . . .	52½	by 30½	236
Double elephant . . . . .	39½	— 26½	140
Atlas . . . . .	33	— 26	100
Colombier . . . . .	34½	— 23	100
Elephant . . . . .	28	— 23	72
Imperial . . . . .	29½	— 21½	72
Super royal . . . . .	27½	— 19½	52
Royal . . . . .	23½	— 19	44
Medium . . . . .	22½	— 17½	34
Demy . . . . .	19½	— 15½	24
Extra large thick post. . . . .	22½	— 17½	25
Ditto ditto thin ditto . . . . .	22½	— 17½	18
Ditto ditto bank ditto. . . . .	22½	— 17½	13
Large thick post . . . . .	21	— 16½	22
Ditto middle ditto . . . . .	21	— 16½	19
Ditto thin ditto . . . . .	21	— 16½	16
Ditto bank ditto . . . . .	21	— 16½	11
Extra thick ditto . . . . .	19	— 15½	25
Thick post . . . . .	19	— 15½	20
Middle ditto . . . . .	19	— 15½	17
Thin ditto . . . . .	19	— 15½	14
Bank ditto . . . . .	19	— 15½	7
Copy . . . . .	20	— 16	17
Sheet-and-half foolscap . . . . .	25½	— 13½	22
Sheet-and-third ditto . . . . .	22	— 13½	20
Extra thick foolscap . . . . .	16½	— 13½	18
Foolscap . . . . .	16½	— 13½	15
Pott . . . . .	15½	— 12½	10

Drawing papers are not made smaller than demy, and are put up into reams in the flat state; writing papers, on the contrary, are not made larger than double elephant, very seldom larger than imperial, and are usually folded. The laid papers are distinguished by certain peculiar water marks; thus, post has a bangle-horn; copy, a fleur-de-lis; foolscap, a lion rampant, or Britannia; and pott paper has the English arms. By a knowledge of these marks, the original size of any paper can at once be discovered, however much it may have been subsequently reduced in size. This observation only applies to the laid papers, as in wove paper the water-mark never appears.

The post papers are seldom sold retail in the folio, *i. e.* the original size, as quoted in the foregoing list; being usually cut in half, folded, and ploughed round the edges, forming, in that state, quarto post, the letter-paper of the shops. This, cut and again folded, forms octavo post, or note-paper; another folding forms 16mo. or small note, &c., and so on to any required extent,—for this repeated folding is frequently carried so far as the production of 64mo. post, or lilliputian note paper. After the paper has been ploughed, the edges are left plain, or they may be gilt or blacked, according to fancy. When papers are folded the broadest way, they are described as broad folio; but if folded the narrow way, they are termed long folio. The other foldings are distinguished in like manner, as long or broad quarto, or octavo. These terms are mostly used in describing account-books.

Writing paper is made in all parts of England; but Maidstone, in Kent, is noted for producing the finest qualities; here all the best drawing papers are made, the celebrated manufactures of "J. Whatman," and the "Turkey Mill," being most in repute.

*Printing Paper.*—At the head of this extensive and highly useful class must be placed the plate papers. They are of the same size, weight, and quality as the drawing-papers, described in the foregoing list, differing from them, how-

ever, in being of a particularly soft and absorbent nature; the process of sizing, which gives the firmness so necessary in papers intended to be written on, being wholly omitted in manufacturing plate-paper. Plate-paper is not made smaller than medium, which is the size necessary for the plates of a demy book. These papers, as their name implies, are used for copper-plate printing. When the plates are to be coloured, drawing-paper is usually employed, then technically termed *hard-plate*, in contra-distinction to the former, or *soft-plate*. When plates that have been printed on *soft* paper require to be coloured, it is necessary first to size the paper, which may very readily be done with a clear solution of isinglass.

For taking proofs from engravings, a paper of Chinese manufacture is employed, well known in the trade under the name of India-paper. In consequence of its peculiarity of fibre, this paper possesses a singular degree of ductility, which enables it to enter the finest lines of an engraving; in addition to this peculiar softness and flexibility of texture, it also appears to have an absorbent and congenial quality for fixing the ink, which causes it to take every light and shade with much less colour and pressure, and, what is of the utmost importance to printers, allows the ink to set and dry in considerably less time than any other paper. India-paper is imported in sheets, fifty-one or fifty-two inches long, by twenty-six inches wide; the weight varies; but one hundred sheets usually weigh about from ten to eleven pounds.

The following is a list of the other papers in this class, the weights and sizes of which vary greatly, according to the choice of the manufacturer.

NAME.	DIMENSIONS.		WEIGHT.	
	Inches.	Inches.	lbs.	lbs.
Large news . . . . .	32	by 22	32	to 37
Small news. . . . .	28	— 21	23	— 25
Royal . . . . .	25	— 20	26	— 28
Medium. . . . .	23½	— 18½	24	— 26
Demy . . . . .	22½	— 18	15	— 21
Short demy, for music . . . . .	20½	— 14	25	— 28
Copy. . . . .	20½	— 16½	13	— 16
Crown . . . . .	20	— 15	7	— 12
Foolscap . . . . .	16½	— 13½	9	— 14
Pott . . . . .	15½	— 12½	9	— 10½

The three last of these are always made in the double size. Printing-papers are generally of a yellow-wove texture, and are not so well sized as the writing-papers; but the sizing is not wholly omitted, as, without some portion of it, they would not possess sufficient strength for ordinary purposes.

We come now to speak of the Wrapping or *Packing-papers*. This class includes an almost endless variety of sorts and sizes, which, for the sake of perspicuity, we shall notice under the following heads; viz., Cartridge-papers, Blue papers, Hand papers, and Brown papers.

#### Cartridge Papers.

NAME.	DIMENSIONS.		WEIGHT.	
	Inches.	Inches.	lbs.	lbs.
Square cartridge . . . . .	33½	by 21½	46	to 50
Double crown ditto . . . . .	30	— 20	30	— 38
Elephant ditto . . . . .	28	— 23	48	— 52
Common size ditto . . . . .	26	— 21	40	— 50
Royal ditto . . . . .	24	— 19½	29	— 32
*Demy ditto . . . . .	22½	— 17½	26	— 28
*Foolscap ditto . . . . .	16½	— 13½	13	— 16

\* These two are mostly made in the double size.

*Blue Papers.*

NAME.	DIMENSIONS.		WEIGHT.	
	Inches.	Inches.	lbs.	lbs.
Blue elephant . . . . .	28	by 23	30	to 32
Ditto double crown . . . . .	30	— 20	20	— 24
Ditto ditto foolscap . . . . .	26½	— 16	18	— 20
Blue royal . . . . .	25	— 20	20	— 22
Ditto demy. . . . .	22½	— 18	15	— 20

*Hand (or white-brown) Papers.*

NAME.	DIMENSIONS.		WEIGHT.	
	Inches.	Inches.	lbs.	lbs.
Elephant . . . . .	28	by 23	30	to 36
Thick royal hand. . . . .	24½	— 20½	36	— 40
Thin ditto ditto . . . . .	24	— 20	16	— 20
Royal curling . . . . .	22½	— 19½	10	— 12
Lumber hand . . . . .	22½	— 18½	13	— 15
Middle ditto . . . . .	22	— 17	12	— 14
Small ditto. . . . .	20	— 15	5	— 10

*Brown Papers.*

NAME.	DIMENSIONS.		WEIGHT.	
	Inches.	Inches.	lbs.	lbs.
Imperial cap . . . . .	29	by 22	50	to 84
Bag ditto . . . . .	23½	— 19½	30	— 48
Kentish ditto . . . . .	21	— 17½	26	— 28
Small ditto . . . . .	20	— 15	10	— 12
Double four pound . . . . .	32	— 20	56	— 66
Small ditto ditto . . . . .	28½	— 17½	42	— 52

There are a variety of papers for particular purposes, which do not properly belong to any of the classes hitherto described; we therefore proceed to notice the principal of them, commencing with *Blotting-paper*, which must be well known to every person; it is made of three sizes, viz. medium, post, and foolscap; the weight, quality, and colour, vary greatly, but the pale red is by far the most used. Blotting-paper, especially the colourless description, is much used in chemical experiments, for the purposes of filtration; there is, however, a paper made expressly for this purpose, known by the name of filtering-paper; it is generally made the size of double crown, and is of a thick, woolly texture.

*Tissue-paper* is also too well known to need description, beyond stating that it is made the size of crown, double and single, and demy. A particular species of tissue-paper is manufactured and sold under the name of copying post; it is wholly destitute of size, and is of a thin absorbent texture; its size is medium; its use is for copying newly-written letters. For this purpose it is slightly moistened, and laid on the letter written with copying-ink, and then subjected to the action of a press, kept in counting-houses for that purpose; on removing the letter from the machine, an accurate fac-simile is found transferred to the copying paper, which pasted in a book, answers all the purposes of the more tedious and laborious methods of transcribing formerly practised.

*Litress* is a kind of smooth cartridge-paper; it is made of two sizes, royal and foolscap, and only used in the manufacture of cards. Besides many of the papers already described, grocers use a thick purple paper, which forms a distinct class, under the title of sugar blues.

*Sugar Blues.*

NAME.	DIMENSIONS.		WEIGHT. lbs.
	Inches.	Inches.	
Large lump . . . . .	22½	by 32	108
Small ditto . . . . .	28½	— 21½	102
Single loaf . . . . .	26½	— 19	80
Powder ditto. . . . .	26	— 18	58
Double ditto. . . . .	22	— 15½	44

Besides the brown papers enumerated, there are some made for particular purposes, among which may be noticed a large coarse paper for strong packing purposes, known by the name of Manchester-papers: sheathing-paper, for the use of ship-builders, and tip-paper for hatters, are also of a similar description.

It may be as well to observe, that although a very marked distinction has been made in the classification of the several papers, yet such in reality does not exist; as the finest printing and sometimes even writing-papers are applied to wrapping purposes; instance the foolscaps, crowns, and demies, used by grocers, batters, and the like. In hand papers, again, some difficulty occurs; elephant, which stands at the head of that class, is used almost exclusively for the manufacture of paper-hangings, being joined together, and printed on: it is made of various qualities, according to the description of work for which it is intended. The elegant crimson and satin hangings require a paper of the best printing quality, which will not, therefore, properly come under the denomination of hand-paper; but had these and similar particulars been permitted to interfere with the plan adopted, much unnecessary repetition and great confusion would have been the inevitable consequence. We have, therefore, given the most usual weights and sizes, which continue much the same, in whatever class the *quality* of the paper may chance to place it.

*Coloured papers* are of two kinds, those which are made at the paper-mill, either by colouring the pulp in the vat, by using coloured rags, or by dyeing the paper afterwards; and those which are made from white papers, by persons following the business of fancy stationers. In the first class, we find the coloured drawing or crayon papers for artists, coloured royal and demy for bookbinders, and the delicate tinted post and tissue-papers, in high repute with the fair sex. The second class comprises, in addition to some of the above, coloured double-crown and demy, for posting-bills, coloured foolscap, (or small post,) plain and glazed for fancy work, and varnish coloured papers, embossed in imitation of watered or figured silk, and morocco leather. To these may be added a very great variety of marble-papers for bookbinding, as also papers beautifully painted in imitation of the various valuable woods and marbles.

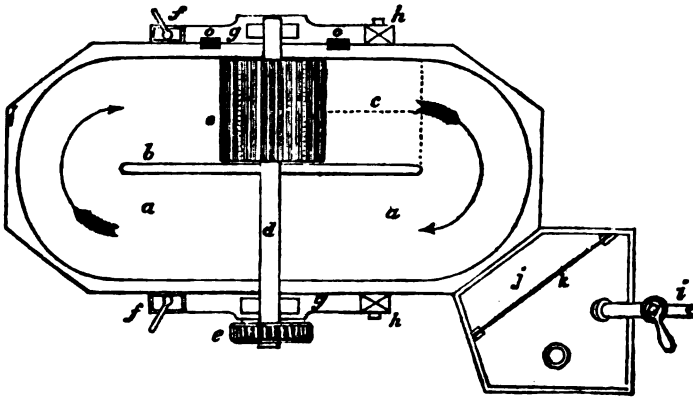
**PAPER MANUFACTURE.** The first paper mill established in England was at Dartford, by a German, (who was jeweller to Queen Elizabeth,) about the year 1588. For a long period afterwards the manufacture was, however, of so inferior a quality as to render it necessary to have recourse to France and Holland for those of the better quality. The process at this time consisted in subjecting the rags to fermentation, by which destructive operation they were of course more easily reduced to a pulpy consistency, which was effected by stamping or triturating in a kind of mortar, similar to the action of the Asiatic oil mill, described at page 201. About the middle of the last century the process was, by successive ameliorations, entirely changed, so as to approximate nearly to that now used in making paper by hand. We shall therefore proceed to describe, in the first place, all the ordinary manipulations practised in making paper by hand; and afterwards, successively, those improvements in the mechanism by which this important manufacture is now conducted.

The best kind of rags employed in the manufacture of paper are collected in this country, but all these are only sufficient to supply a fifth part of our demand; and the inferior kinds are imported from the continent, particularly from Hamburg, whence our chief supply has been drawn for many years, that city being apparently the grand rag-market for the German States and the north of Europe. France, Holland, and Belgium, prohibit the exportation;

a considerable quantity is, however, brought to us from Italy, and various parts of the Mediterranean. These rags are of course of every quality, from canvas to cambric, and of every tint, as respects filth or cleanliness, between white and black; those from Sicily have the hue of sepia. Notwithstanding they undergo, from their excessively filthy state, a partial cleansing before they can be shipped, they become so completely metamorphosed by the ablutions and manipulations of our paper makers, as to be converted, in a very short space of time, into a pure and spotless white paper. Before rags are brought to the mill, they are roughly sorted into several qualities, distinguished by technical terms, understood by the trade. At the mill, these sorts are more particularly sorted, according to the requirements of the manufacturer, and at the same time they are cut into pieces, if they are much larger than about the palm of the hand. A number of women are employed for this purpose, in a large room, fitted up and adapted to reduce the nuisance of the filth and dust of the operation. Each woman stands before a kind of table, formed of a wire screen, on which the rags she sorts are from time to time distributed, and moved about, which causes much of the dust and dirt to pass through the wires into receptacles beneath. At each stand there is also a fixed blade of steel, kept very sharp, over which the workwomen draw those pieces of rags that are too large, and thus quickly divide them. If the pieces be small enough, they throw them, according to their respective qualities, into one or other of a series of receptacles designed to receive the various qualities in a separate state. All the seams in the rags are carefully separated; as the sewing threads, if not thoroughly torn into filaments by the engine, would produce indentations or knots upon the paper. An active woman can cut and sort about a hundred-weight a day; the rags are next weighed, and put up into hundred-weight bags, ready for the subsequent operation. It was formerly necessary to assort the rags with great care, with respect to colour, as well as texture; but from this care they are now in a great measure relieved, by the introduction of bleaching by chlorine, which enables them to produce the whitest paper from any kind of rags: by injudicious management, however, the process is sometimes carried too far, and the tenacity of the vegetable fibre destroyed. The next operation is to boil the rags for some hours with lime, which loosens the dirt, and partially cleanses them; but this preparatory process for the operations of the mill is, we believe, confined to the most improved mills.

The paper-mill consists of a water wheel, or other first mover, connected with a combination of toothed and other wheels, so arranged as to cause the cylinder in the *washer*, and the one in the *beating* engine (which are nearly of a similar construction,) to make 150 or more revolutions per minute. On the same shaft, and of the same size as the water wheel, is a cogged wheel, which gives motion to a pinion, on whose axis is a two or three-throw crank, that works as many pumps, which raises a constant stream of water from the mill-dam; this water is kept constantly running through the rags in the washing and beating engines. The building and machinery of a paper mill should be well constructed, otherwise the great velocity of the wheels produces a tremor, which in time shakes it all to pieces. A washing engine, when it revolves at the rate of 120 revolutions per minute, and has 40 teeth, each of which passes by 14 teeth in the block, produces 67,200 cuts in a minute, and makes a most horrible growling noise; but in the beating engine, in which the cutters and teeth are smaller, and the revolution more rapid, the noise produced is one continued loud humming. The cuts made in the latter amount to nearly 200,000 per minute, which circumstance will account for the rapidity with which the rags are converted into a pulpy mass, in which the filaments are so minute as to be scarcely discernible. The washing engines of a mill are placed at a higher elevation than the beating engines, and they are actuated in the following manner. The large cogged wheel, before mentioned, drives a pinion upon a vertical axis; upon this axis are two horizontal spur-wheels, at different elevations; the upper one drives a pinion on the axis of the washing engine, and the lower one a pinion on the axis of the beating engine; and as these engines are similar in their arrangement of parts, and differ only in certain proportions, we shall make the subject intelligible by the description of one only. The figure on the next page

represents a plan of one of these engines. *a a* is a wooden vat or cistern, about 10 feet long, 4½ wide, and 2½ deep, the inside lined with lead; *b* is a longitudinal



partition, also covered with lead; *c* is a reticulated cylinder, fixed fast upon the revolving shaft *d*, extending across the engine, and put in motion through the medium of the pinion *e*, driven by a toothed wheel on the vertical shaft of the mill, as before mentioned. This cylinder is made of wood, and furnished with a number of parallel blades, fixed longitudinally around its circumference. Immediately beneath this cylinder is a block of wood extending its length, and of the breadth of the space between the two dotted lines represented. The upper surface of this block conforms to the curvature of the cylinder, and it is provided with teeth or blades, placed close together, so as to present so many acute cutting angles, which present themselves constantly to the teeth on the revolving cylinder, not in contact, but so near as to cut, chop, and tear the rags as they are forced between them by the action of the machine. The distance between these opposed series of teeth is always susceptible of regulation, by turning screws at *ff*, which raise or lower the bearings *gg* of the axis of the cylinder, which bearings are levers turning upon fulcrums at *hh*. The engine is served with water by a pipe *i* from a reservoir supplied by the pumps, which it delivers into a small cistern *j*, communicating with the engine. This pipe is provided with a cock, to stop or regulate the quantity of water; and to prevent any extraneous matter passing with the water into the engine, it has a hair or wire strainer *k* placed across it. When the engine is filled with water, and a quantity of rags put in, they are, by the revolution of the cylinder, drawn between its cutters and those on the block underneath. This cuts them into pieces; then, by the rapid motion of the cylinder, the rags and water are thrown upwards over a breast, which rises in the same curve with the toothed block, up to about the middle of the cylinder; from this point they descend an inclined plane, whose length is represented by the dotted line *l*, and take a course round the vat, as indicated by the arrows; the whole contents of the vat are thus put into motion, which continues as long as the cylinder revolves; that being of course determined by the uniform reduction of the rags into a pulpy consistency. The outer block is made so as to slide into or out of its place from the outside of the machine, for the convenience of sharpening its teeth, &c. The cutters of the cylinder are fixed into grooves made in the wood of the cylinder, at equal distances from each other around its circumference, in a direction parallel to its axis; the number of these grooves is twenty; and for the washer, each groove has two cutters or blades put in it; then a fillet of wood is driven fast in between them, to hold them firm, and the fillets are nailed fast into the solid



wood of the cylinder. The beater is made in the same manner, except that each groove contains three bars and two fillets.

In the operation of this cylinder, it is necessary it should be inclosed in a case, or its great velocity would throw all the rags and water out of the engine. The case is a wooden box, inclosed on all sides except the bottom; one side of it rests on the edge of the vat, and the other upon the edge of the partition *b*. Inside this case are two hair or wire strainers, through which the foul water passes as it is dashed against them, and on the opposite side of these strainers the case is formed so as to conduct the foul water into two flat lead pipes, seen in section at *o a*, out of the machine. When the water is not required to be carried off, as in the beating engines, there are sliding shutters provided to these sieves, which pass through grooves on the top, and at the sides of the case, by which the water as well as the rags are returned into the engine.

When the rags have been about an hour in the first engine, if they require it, according to the modern practice, they are bleached. There are two ways of bleaching used at present; one by the oxymuriatic acid gas, the other by the acid combined in the dry way with quicklime. In the first way, the rags are boiled in an alkaline solution of potash and lime for four or five hours, or if very coarse, for eight hours. The purpose of this is to destroy the coarse part of the hemp, commonly called shon or sheave, and which exists in a great degree in coarse linens, especially German rags. The solution is then washed out in the washing engine; the water being pressed out, they are exposed to the acid in the gaseous form, as linen is; (see the article BLEACHING.) The gas is then washed out as carefully as possible; this is of great importance, as, if any acid remain in the rags, it causes the paper, after some time, to putrefy and change its colour. In the other way, the oxymuriate of lime is diffused in water by agitation, the insoluble matter is thrown out, and the liquid, when clear, is diluted and put in the engine; being thoroughly mixed with the rags, it is allowed to stand for an hour or more, and the acid carefully washed out. Bleaching is not now quite so much practised as formerly, on account of the low price of rags; indeed, we understand that unbleached papers are entirely used in the Oxford University Press, for the printing of bibles, testaments, &c., on account of their great durability. After the bleaching, (if that process is used at all,) the stuff is reduced for an hour or more in the washing engine, and is then put into the beating engine. When it has been beat, as it is called, for about three hours and a half, it is generally fine enough, and a valve placed in the bottom of the engine being opened, the stuff escapes into the chest, or general reservoir, which supplies the vat or other machinery.

We shall now proceed to describe the mode of making paper by hand, without the aid of machinery, (in the common acceptation of that term.) The vat is made of wood, and generally about five feet in diameter, and two and a half in depth. It is kept at the required temperature by means of a grate, introduced by a hole, and surrounded on the inside of the vat by a case of copper. For fuel to this grate, charcoal or wood is used; and frequently, to prevent smoke, the wall of the building comes in contact with one part of the vat, and the fire has no communication with the place where the paper is made. Every vat is furnished on the upper part with planks, inclosed inwards, and even railed in with wood, to prevent any of the stuff from running over in the operation. Across the vat is a plank, which is called the trepan, pierced with holes at one of the extremities, and resting on the planks which surround the vat. The moulds are composed of wire cloth, and a movable frame. The wire cloth is varied in proportion to the fineness of the paper, and the nature of the stuff. A laid mould consists of a frame of wood, neatly joined at the corners. Wooden bars run across it, about an inch and a half distance from each other. Across these, and consequently along the mould, the wires run, from fifteen to twenty in an inch. A strong raised wire is laid along each of the cross-bars, to which the other wires are fastened; this gives the laid wire its ribbed appearance. The water-mark is formed by sewing a raised piece of wire, in the form of letters, or any device that may be wished, on the wires of the mould, which makes the paper thinner in these places. The frame-work of a wove mould is nearly the

same: but, instead of sewing on separate wires, the frame is covered with fine wire-cloth, of from 48 to 64 wires in an inch. On both moulds a deckle, or movable raised edging, is used; this must fit very neatly, otherwise the edge of the paper will be rough. The felts are pieces of woollen cloth, spread over every sheet of paper, and upon which the sheets are laid, to detach them from the form, to prevent them from adhering together, to imbibe part of the water with which the stuff is charged, and to transmit the whole of it, when placed under the action of the press. The two sides of the felt are differently raised; that of which the hair is the longest is applied to the sheets which are laid down; and any alteration of this disposition would produce a change in the texture of the paper. The stuff of which the felts are made should be sufficiently strong, in order that it may be stretched exactly in the sheets without forming into folds; and, at the same time, sufficiently pliant to yield to every direction, without injury to the wet paper. As the felts have to resist the reiterated efforts of the press, it appears necessary that the warp be very strong, of combed wool, and well twisted. On the other hand, as they have to imbibe a certain quantity of water, and to return it, it is necessary that the wool be of carded wool, and drawn out into a slack thread. After the stuff is ready, the workman takes one of the moulds, furnished with its frame, by the middle of the short sides, and fixing the frame round the wire-cloth with his thumbs, he plunges it obliquely four or five inches into the vat, beginning by the long side, which is nearest to him. After the immersion, he raises it to a level; by these movements he fetches up on the mould a sufficient quantity of stuff; and as soon as the mould is raised, the water escapes through the wire-cloth, and the superfluity of the stuff over the sides of the frame. The fibrous parts of the stuff arrange themselves regularly on the wire-cloth, not only in proportion as the water escapes, but also as the workman favours this effect by gently shaking the mould; afterwards, having placed the mould in a piece of board, the workman takes off the frame or deckle, and glides it towards the coucher, who, having previously laid his felt, places it with his left hand in an inclined situation, on a plank fixed in the edge of the vat, and full of holes. During this operation the workman applies his frame, and begins a second sheet. The coucher seizes this instant, takes with his left hand the mould, now sufficiently dry, and laying the sheet of paper upon the felt, returns the mould, by gliding it along the trepan of the vat. They proceed in this manner, laying alternately a sheet and a felt till they have six quires of paper, which is called a post; and this they do with such swiftness, that in many sorts of paper two men make upwards of twenty posts in a day. When the last sheet of the post is covered with the last felt, the workmen about the vat unite together, and submit the whole heap to the action of the press. They begin at first to press it with a middling lever, and afterwards with a lever of great length. After this operation another person separates the sheets of paper from the felts, laying them in a heap; and several of these heaps collected together are again put under the press. The stuff which forms a sheet of paper is received, as we have already said, in a form made of wire-cloth, which is more or less fine, in proportion to the stuff, surrounded with a wooden frame, and supported in the middle by many cross-bars of wood. In consequence of this construction, it is easy to perceive that the sheet of paper will take and preserve the impression of all the pieces which compose the form, and of the empty spaces between them. The traces of the wire-cloth are evidently perceived on the side of the sheet which was attached to the form, and on the opposite side they produce an assemblage of parallel and rounded risings. As in the paper which is most highly finished, the regularity of these impressions is still visible, it is evident that all the operations to which it is submitted have chiefly in view to soften these impressions without destroying them; it is of consequence, therefore, to attend to the combination of labour which operates on these impressions. The coucher, in turning the form on the felt, flattens a little the rounded eminences which are in relief on one of the surfaces, and occasions, at the same time, the hollow places made by the wire-cloth to be partly filled up; meanwhile, the effect which is made in detaching the form produces an infinite number of

small hairs on every protuberant part of the sheet. Under the action of the press, first with the felts, and then without them, the perfecting of the grain of the paper still goes on. The vestiges of the protuberances made by the wires are altogether flattened, and, of consequence, the hollows opposite to them disappear also; but the traces formed by the interstices of the wire in consequence of their thickness, appear on both sides, and are rounded by the press. The paper, the grain of which is highly softened, is much fitter for the purposes of writing than that which is smoothed by the hammer; on the other hand, a coarse and unequal grain very much opposes the movements of the pen, as that which is beat renders them very uncertain. The art of making paper, therefore, should consist in preserving, and, at the same time, in highly softening the grain.

The exchange succeeds the operation last described; it is conducted in a hall contiguous to the vat, supplied with several presses and a long table. The workman arranges on this table the paper newly fabricated, into heaps, each heap containing eight or ten of those last under the press, kept separate by a woollen felt: the press is large enough to receive two of them at once, placed the one at the other's side, and must have a power from 70 to 100 tons. When the compression is judged to be sufficient, the heaps of paper are carried back to the table, and the whole turned, sheet by sheet, in such a manner that the surface of every sheet is exposed to a new one; and in this situation they are again brought under the press. If the stuff be fine, or the paper slender, the exchange is less frequently repeated: in this operation it is necessary to alter the situation of the heaps, with regard to one another, every time they are put under the press; and, also, as the heaps are highest toward the middle, to place small pieces of felt at the extremities, in order to bring every part of them under equal pressure. A single man, with four or five presses, may exchange all the paper produced by two vats, provided the previous pressing at the vats has been well performed. The work of the exchange generally lasts two days on a given quantity of paper. The sheds for drying the paper are contiguous to the mill; they are furnished with a vast number of cords, upon which they hang the sheets both before and after the sizing. The sheds are surrounded with movable lattices, to admit a quantity of air sufficient for drying the paper. The cords of the sheds are stretched as much as possible; and the paper, four or five sheets together, is placed on them by means of a wooden instrument in the form of a tall T. The principal difficulty in drying the paper consists in gradually admitting the external air, and in preventing the cords from imbibing moisture.

The inconvenience of the expansion and contraction of the cords from alterations in their humidity, might, we conceive, be remedied by saturating them in a solution of caoutchouc, which would not destroy their flexibility, but would enable them to resist moisture, and render their durability almost everlasting. In some mills the paper is hung upon smooth, rounded laths, and the drying is effected by steam or hot water, circulated in pipes through the room.

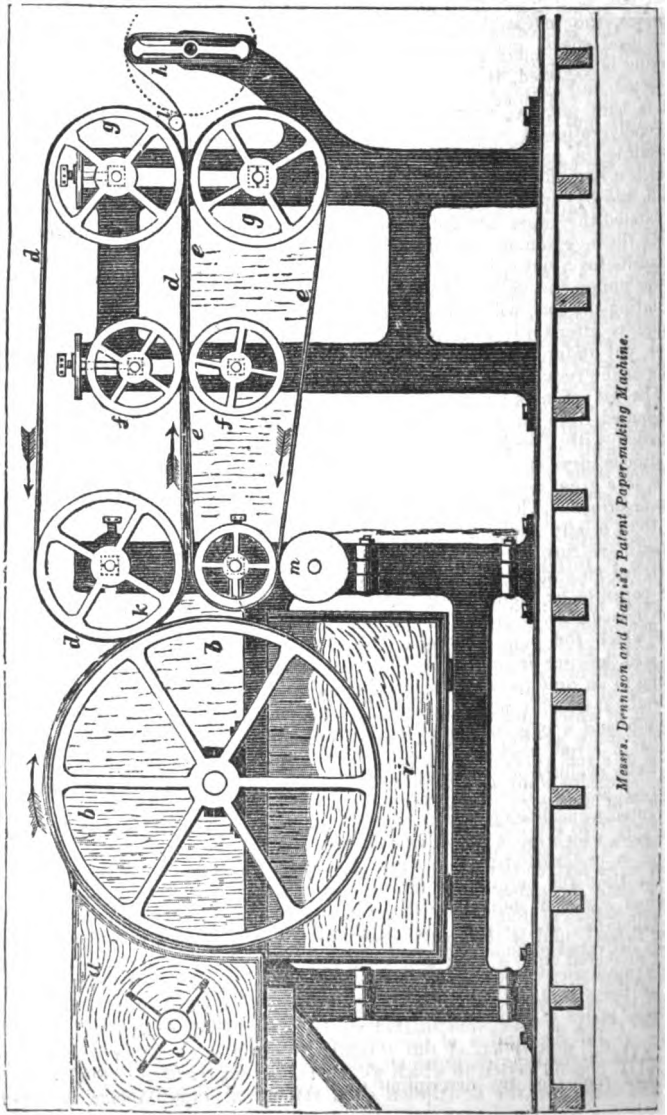
The size for the paper-makers is made of the shreds and parings procured from the tanners and parchment-makers. All the putrefied parts, and the lime, being separated from them, they are enclosed in a kind of basket, and let down by a rope and pulley into a cauldron. When the solution of the gelatin is found to be complete (which is ascertained by drawing up the basket), it is allowed to settle for a while, and then twice filtered, before it is put into the vessel into which the paper is dipped. After this a certain quantity of alum, also of smalts, or other pigments calculated to improve the tint, or bestow a peculiar hue upon the paper, is added. The workman then takes a handful of the sheets, smoothed and rendered as supple as possible, in his left hand, dips them into the vessel, and holds them separate with his right, that they may equally imbibe the size. After holding them above the vessel for a short time, he seizes on the other side with his right hand, and again dips them into the vessel. When he has ten or a dozen of these handfuls, they are submitted to the action of the press. The superfluous size is carried back to the vessel by means of a small pipe. The vessel in which the paper is sized is made of

copper, and furnished with a grate, to give the size, when necessary, the requisite temperature; and a piece of thin board, or felt, is placed between every handful as they are laid on the table of the press. After the paper is sized it is carried to the drying house, where a gradual drying of the sized paper is considered to be very important; the exchange, likewise, at this stage, requires great attention, as the grain of the paper, which may then receive impressions, can never be restored. When the sized paper is also exchanged, it is possible to hang more sheets together on the cords of the drying house: the paper dries better in this condition, and the size is preserved without any sensible waste, because the sheets of paper mutually preserve the rapid operation of the external air; and as the size has already penetrated into the paper, and is fixed on the surface, the insensible progress of a well-conducted drying house renders all the good effects more perfect in proportion as it is slowly dried. When the drying is completed, it is carried to the finishing room, where it is pressed, selected, and examined; folded, made up into quires, and, finally, into reams. It is here put twice under the press; first, when it is at its full size, and, secondly, after it is folded. The principal labour of this place consists in assorting the paper into different lots, according to its quality or defects; after which it is made up into quires. The person who does this must possess great skill, and be capable of great attention, because he acts as a check on those who separated the paper into different lots: he takes the sheets with his right hand, folds them, examines them, lays them over his left arm till he has the number requisite for a quire, brings the sides parallel to each other, and places them in heaps under the table. An expert workman, if proper care has been taken in assorting the lots, will finish, in this manner, about 600 quires in a day. The paper is afterwards collected into reams of 20 quires each, and, for the last time, put under the press, where it is continued for ten or twelve hours, or as long as the requirements of the paper-mill will permit.

The art of making paper in one continuous sheet of any required length, originated from an ingenious Frenchman of the name of Didot, who, in conjunction with the Messrs. Fourdrinier, succeeded, after the expenditure of enormous sums of money, in perfecting this important improvement, which has now, in a great measure, superseded the desultory mode of operating we have just described. The action and arrangement of the improved mechanism may be thus briefly explained. A horizontal frame, of any required length or breadth, is furnished with a roller or cylinder at each end, over which is stretched an endless web of brass wire, of the requisite texture or fineness, for the paper to be manufactured by it. At one end of the frame, parallel with, and immediately over one of the cylinders, is a long angular trough, or sluice, into which the pulp is received from a vat above, wherein it is continually agitated, whence it issues through a long slit or opening, regulated by a screw, falling in an uniformly thin stratum upon the whole breadth of the endless web beneath, at which time the cylinders are in motion, carrying forward the stratum of pulp, and a joggling motion is communicated to it laterally by the alternating motion of a rod, produced by a revolving crank; this agitation of the pulp, as the water drains from it through the wire-work, produces the felting, or interweaving of the fibre, as perfectly as it is done by hand; and the pulp is prevented from flowing over the sides by means of two leather straps, one on each side, which move round with the web; and by the shifting of which straps nearer to, or farther from the centre, the width of the paper may be regulated. By the time the pulpy mass arrives to the farthest end of the machine, it has acquired sufficient tenacity to be taken up by a larger cylinder, covered with felt or flannel, and is then passed between a series of similar cylinders, and finally delivered on to a reel; and when this reel has sixteen or eighteen quires wound upon it, it is removed, and another put in its place; the paper is now cut off the reel by a longitudinal incision through the coil, when it undergoes a similar series of operations to that we have described in making paper by hand. A full description of this machine is given in the *Repertory of Arts*, Vol. XIII. Second Series, to which we must refer our readers, in order that we may find room for the description of a variety of improvements in paper-

making, founded upon the admirable mechanism we have briefly noticed, for which the public stand indebted partly to the skill, and wholly to the determined perseverance of the Messrs. Fourdrinier. It is indeed to be lamented that these gentlemen have never received any adequate remuneration for the benefit which they have conferred upon their country.

The first invention which we have to notice possesses a considerable degree of novelty and ingenuity; the authors and patentees of which are Messrs. Dennison and Harris, paper-makers, of Leeds. The paper-mould is, in this



*Messrs. Dennison and Harris's Patent Paper-making Machine.*

case, continuous, but differently arranged, forming simply the exterior or periphery of a large drum, which revolves in the pulp vat. The preceding engraving exhibits an elevation of the apparatus, shown partly in section. *a* is a vessel containing the pulp, considerably diluted, which is preserved at the desired level by any of the usual means, so that the pulpy liquid, when the machine is at work, shall flow over the curved side of the vessel into a revolving cylindrical mould *b*. In the vessel *a*, a vane *c* is made to revolve, to keep up a powerful agitation, and prevent any of the fibres from subsiding. The rotatory mould *b* is formed on its periphery like a sieve (which will, hereafter, be particularly described), and, as it turns round in the direction of the arrow, the pulp is received upon it; the chief part of the water instantly drains through the bars of the mould, and the paper, in a loose, spongy, wet state, is formed. The continued motion of the mould brings this pulpy matter in contact with an endless felt *d*, which, by a superior attraction of cohesion, attaches to itself the pulpy fabric, and carries it forward between that felt and another felt *e*, where it receives pressure, first from a pair of *wet rollers f f*, then a greater pressure from the *dry rollers g g*; from thence the paper, in a comparatively dry state, is taken up by a rotatory vane *h*, upon which it is folded; when this vane is fully charged it is removed, and another vane substituted in its place. In this manner a sheet of any required length may be made. The cylindrical mould *b* revolves in a vessel of water *i*, which serves to wash off the fibrous matter that may adhere to it, and to receive the water which drains from the diluted pulp as it passes over. The cast-iron frame upon which the mould revolves is jointed, to facilitate that lateral shaking or trembling motion, essential in the making of paper, which is effected by a crank and rod, or by any of the other usual means, motion being communicated from the gearing which drives the rollers, &c. The roller *k* is called the *combing roller*, as it takes the paper off the mould. This roller is provided with a regulating screw, to tighten the web, or adjust the pressure against the mould. The upper wet rollers *f*, and the upper dry rollers *g*, have also regulating screws, by which they may be elevated or depressed in the long slots wherein their axes revolve, so as to increase or diminish the pressure upon the wet paper. A small roller *l* is employed for assisting in separating the paper as it passes from the felt on to the vane *h*. As the lowermost web becomes very wet by receiving the water from the paper, a small cylinder *m* is employed to press out the water from it as it revolves. For the perfect cleansing of the webs from the fibrous matter, small rotatory brushes are directed to be fixed so as to brush over their surfaces; and the employment of jets of water to wash over the felts is also recommended by the patentees. As the peculiar construction of the rotatory mould forms the principal feature of this invention, and the ground of patent-right, it is proper that we should describe it more particularly. In its outline it presents precisely the figure of a military drum; its periphery is formed by connecting together a series of metallic rings; the cylinder is then covered longitudinally with numerous small thin bars of copper, three-eighths of an inch wide, placed edgeways, so as to form a complete grating over the whole surface. The copper bars have numerous small lateral projections, to keep them at a regular distance apart; these are directed to be made by passing plain slips of copper between cylindrical steel rollers, with indentations on one of them, adapted for producing a uniform series of little slabs.

It has been usual to distinguish laid paper (or paper made in hand moulds) from machine paper, (or that made on the endless wire web in a machine,) by the peculiar water-mark lines. Hitherto the machine paper has been made on very fine woven wire, which gives it that smooth, woven appearance; while the laid paper is marked by distinct parallel lines, crossed by a few thicker lines about an inch apart. The usual process of working wire, in making the hand moulds that produce the last-mentioned effect, is tedious and expensive; but the paper made from them is generally preferable, and, we believe, is worth more in the market.

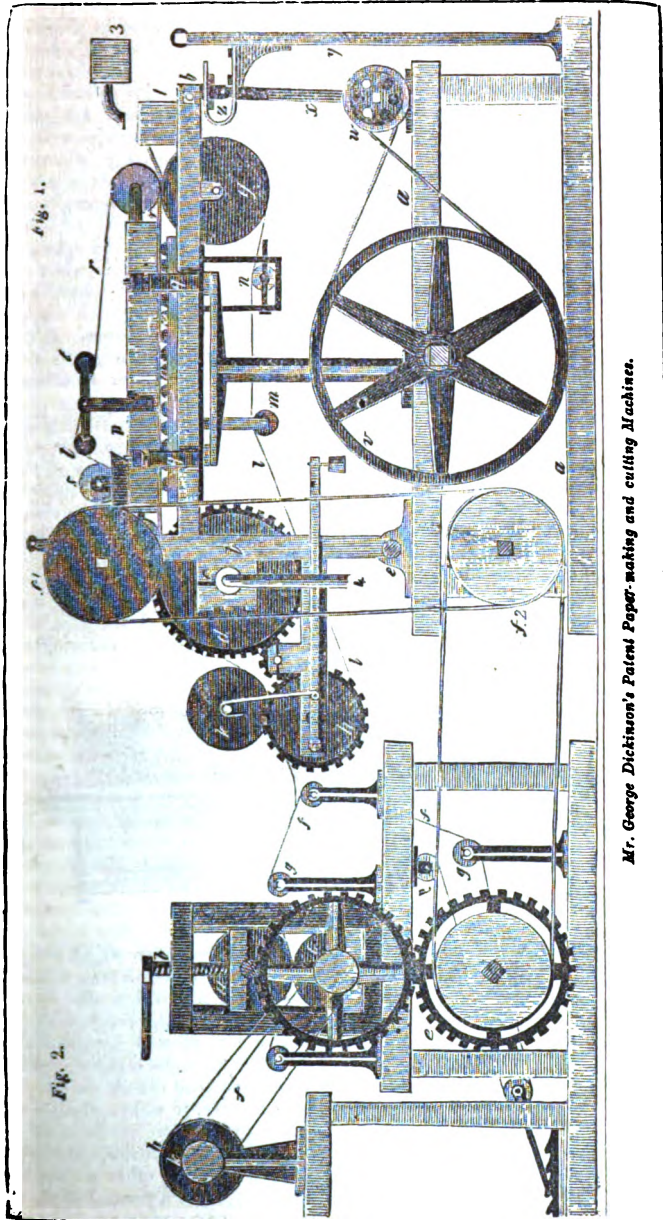
The object of the invention we shall next describe, is to make a paper resembling the hand paper, by a machine. For this purpose. Mr. Louis Aubrey, of

Two Waters, in Hertfordshire, took out a patent in 1827, for an endless web of wire, that will produce the same kind of water-marks as are exhibited in the laid paper. The warp, consisting of the small wires, is put into the loom in the usual way, until the reed is filled to the width required. A wooden or metal roller, about five inches in diameter, containing in a line firmly fixed as many metallic pegs as there are large water lines required in the paper: these pegs stand out from the roller about a quarter of an inch, and answer to corresponding large divisions left in the reed. The large warp is then placed on to each of these pegs, and round the roller, until a sufficient length is obtained: the ends are then passed through the front harness, placed somewhat higher than the small harness, and from thence through the large divisions in the reed, where the ends are made fast to stout iron rods. In this manner both warps are drawn tight, and the weaving is executed by the usual process. The superior thickness of the wires of the large warp causes them to project, and to produce the coarse water lines in the paper made with it.

About the same period of time, Messrs. J. and C. Phipps, of London, took out a patent for a different mode of producing the laid paper impressions in a machine, which is of easy application to a Fourdriniers' machine, as it consists simply in the addition to the latter of a revolving cylinder, which impresses the peculiar water lines required upon the wove paper as the latter is received upon the felt. For this purpose, the cylinder is formed of wooden discs at the ends, and concentric rings, and turns on a central iron axle. Over the periphery of the cylinder, the same kind of wire-work as the laid paper moulds are made of, is wound round, and carefully joined at the seam. This cylinder is mounted over the felt, so as to rest its weight upon it, by turning loosely in vertical slots, made in brass bearings on the side frames of the machine; the wire-work, therefore, passing upon the newly-made wet paper on the felt, produces the required water lines.

Mr. George Dickenson, of Buckland mill, near Dover, who has shown equal skill and perseverance in improving the mechanism of the paper manufacture, for which he has had many patents, obtained one in 1828, which, combining several previous improvements, we shall here describe. In the machines we have already noticed, it will be observed that a lateral or horizontal motion is given to the endless web of wire for felting the fibres, and separating the water from the pulp. The leading objects of this invention are to give a rapid vibration to the wire web in a vertical direction, and by rarefying the air underneath the wire web, cause the atmosphere to press upon the superior surface of the paper, by which a farther portion of the water is driven through the paper into the rarefied apartment underneath, and thus the paper is more speedily and effectually dried. From this account, somewhat of the nature of the machine may be understood. We will now describe the arrangements more particularly, with reference to the accompanying engravings. The engraving on the next page exhibits side elevations of two distinct machines, which are brought into action together; they are marked *Fig. 1*, *Fig. 2*, and *Fig. 3*, which follows it, exhibits a longitudinal section of the exhausting cylinder only. In *Fig. 1*, *a a* is a wooden frame supporting the whole; *b b b* an iron frame secured to a similar one on the opposite side by a rod at top, and a bar at the end, and vibrating on a pivot *c*; *d* a cylinder, revolving on a fixed axis *e*; *f 1* and *f 2* band wheels, which give motion to the cylinder *d* by a toothed wheel on the axis of *f 1*, shown by dots, which takes into another toothed wheel on the cylinder *d*; *g* a cylinder revolving in pivots, supported by the frame *b b*; *h* a roller set in motion by the pinion (shown) driven by the toothed wheel on *d*, and which takes into another wheel on the end of the roller *h*; *k* another roller turning in grooves by being placed in contact with the revolving roller *h*; *l l l* an endless web of wire passing over the cylinders *d* and *g*, also betwixt the rollers *h* and *k*, and over the tightening rollers *m* and *n*, the latter of which is movable by a screw, in order to regulate the tension; *o o* a series of rollers supporting the wire web, and revolving upon spindles in notches cut in the side rails, attached to the frame *b b*; *p* a stout piece of brass called the deckle, placed on each side of the machine, over the wire web, and supported by the cross bars *q q*.

which can be raised or lowered by screws in side pieces attached to the frame *bb*; *rr* the deckle straps, revolving over pulleys attached to each end of the deckle, also over similar pulleys on the axis of *f* 1, and under a pulley *s*, dipping into



*Mr. George Dickinson's Patent Paper-making and cutting Machines.*

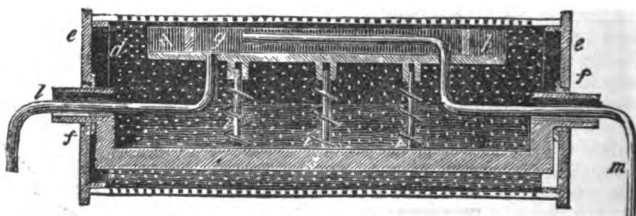


a vessel of water; the straps confine the pulp at the sides of the web, and regulate the width of the paper, which is according to the distance the deckles are asunder; *tt* tightening rollers, to tighten the deckle straps; *v* a large band wheel, driven by the prime mover, and driving the smaller band wheel *w*; the latter carries a crank (not seen) set three-eighths of an inch out of the centre of the axis of the wheel, but which eccentricity can be altered at pleasure; *a* a connecting rod attached to the crank and to the frame *b*, causing the latter to rise and fall three-quarters of an inch at each revolution of the wheel *w*; *y* an iron stand, and supporting the spring *x*, upon which the frame *b* strikes at each descent of the connecting rod *x*, and thus assists the crank. 1 a pulp-box, attached to the frame *b*, and extending the whole width of the wire web; to the front board is attached a piece of leather, which descends on to the wire web, and distributes the pulp equally over the web; 2 a thin piece of board, set edgeways upon the wire-web between the deckles, and keeping back the bubbles of air and water in the pulp; 3 a fixed pulp-box, which feeds the box 1, and regulates the quantity therein; 4 a pipe leading from the cylinder *d* to the air pump. *Fig. 2*, *a*, a metal roller revolving on bearings, which can be raised or lowered by the screw *b*; *c* another roller, revolving in a fixed bearing; this roller is set in motion by the toothed wheel *d* on its axis, which is driven by the wheel *e*, the latter receiving its motion from the prime mover. *ff* an endless web of felt, passing round the small rollers *ggg*, and between the rollers *a* and *c*; *h* the reel, turned by a pulley *k* on its axis; the latter is driven by a band passing over it, and a pulley on the axis of *e*.

The operation of the machine is as follows: the pulp flows from the box 3 into the box 4, thence is distributed by the leather on to the wire web; on arriving at the cylinder *d* the paper receives a considerable degree of pressure upon its external surface from the atmosphere, owing to the air being rarefied in the interior of the cylinder by means of an air pump attached to the pipe 4; and the paper is thus deprived of the principal part of its water. The continuous sheet of paper then passes between the rollers *h* and *k*, and thence on to the endless web of felt, when the remaining water it contains is pressed out by the rollers *a* and *c*, *Fig. 2*, preparatory to its being coiled upon the reel *h*.

*Fig. 3*, a section of the cylinder *d*. *d* is the exhausting cylinder, of brass, and pierced full of holes; *ee* end pieces bolted to *d*, and carrying toothed

*Fig. 3.*



wheels upon their peripheries; *ff* a hollow fixed centre, upon which *d* revolves, and bent into the form of a crank; *g* a trough composed of an iron bottom with wooden sides, and having two movable end pieces *h h*, which are set to the width of the paper; the whole is covered with leather; this trough is supported by the standards *iii* fixed into the axis *ff*, and is pressed by spiral springs against the cylinder *d*; *l* a pipe fitted into the bottom *g*, the outer end plunging in water. *m* a pipe pierced full of holes, and leading to the air pump.

Mr. John Dickenson, of Nash Mills, Hertfordshire, to whom also the public stand indebted for several improvements in the paper manufacture, took out a patent in 1829 for "a new improvement in the method of manufacturing paper by machinery, and also a new method of cutting paper or other materials into single sheets or pieces, by means of machinery." From a perusal of the specification, we find these to consist, first, in causing the paper to be pressed between

two rollers, the upper of which is to be heated by steam in the usual way, first with one side, and afterwards with the other upwards, to give it an equal gloss on both sides; secondly, to introduce, during the manufacture, into the centre of the paper, threads, fine net, or other reticulated material; and thirdly, to cut it into a sheet of appropriate size, by a more convenient and expeditious method than those now in use. The first object he effects by carrying the paper upon felt, round a series of rollers, similar to those employed in the double machines for printing both sides of a sheet of paper at one time; the second, by placing over the pulp vessel a series of bobbins with thread, or a roller with any other material to be introduced into the paper. These threads are guided, by a grooved roller, into the pulp close to the first or feeding roller, which takes up the pulp to form the paper, and, by the current of the pulp approaching the feeding roller, the threads are brought into contact with it. The third improvement he effects by affixing to the bottom of a tall, oscillating frame, a series of circular revolving cutters; and when this frame is made to oscillate, and the cutters to revolve, they traverse along the edge of stationary cutters, on which the paper to be cut is extended, and thus the advantages of a clipping action is obtained.

In a subsequent patent granted to the last-mentioned Mr. John Dickenson, in October 1830, for an improvement upon his previously patented machinery, his object is to make thicker paper of a better quality than could be produced by the existing mechanism. To obtain this result, he employs *two* cylinders for taking up the pulp from separate troughs at the same time, from each of which a web of wet paper is conveyed, by means of endless felts, to a pair of rollers, where they are united by pressure, the subsequent manufacture of the paper being completed in the usual manner. To have a clear idea of this arrangement, it is only necessary to consider, that a duplicate of the pulp cylinder of the common machines is introduced in any convenient situation, governed by the localities of the mill; and that it is actuated by the same machinery which turns the first cylinder.

In the month following the grant of the last-mentioned patent, another was obtained by Mr. John Hall, jun., of Dartford, for "a machine upon a new and improved construction for the manufacture of paper," which we find, by a perusal of the specification, to be for precisely the same object as Mr. John Dickenson's; but the process adopted by Mr. Hall is much more elegant and scientific. In order to collect to the surface of the main cylinder of the machine a quantity of pulp sufficient to make paper of any required thickness, Mr. Hall employs an hydraulic pressure, in the following manner:—the cylinder is made to turn in a vessel supplied with pulp on the one side, and clean water on the other, which rises considerably on its exterior, and through the axis, which is made hollow for the purpose, and has a bent pipe extending from it to the lowest part. The water is continually pumped from the interior of the cylinder; and thus, by the difference in the altitude of the water inside and outside, an hydraulic pressure will be obtained, variable at pleasure, and available in causing a greater or less quantity of pulp to adhere to the surface, which is covered with wire-gauze, supported by strong ribs, to admit of the passage of the water from the exterior to the interior.

The next invention we have to notice is by Mr. Wilks, one of the partners of the firm of Bryan, Donkin, & Co., engineers of great experience and celebrity in this department of mechanism; they having been almost unceasingly engaged in the construction of the Fourdrinier, and other paper machines, from their earliest introduction to the present time: any improvement, therefore, emanating from that house, carries with it a recommendation for utility. The improvement contemplated by this patentee is the application of an additional roller to the Fourdrinier machines. The additional roller is to be perforated, and it is intended to facilitate the escape of the water from the pulp web, previously to its being subjected to the pressing rollers. Still more to facilitate the abstraction of the water, Mr. Wilks proposes to employ the pressure of the atmosphere, by making a vacuum within that part of the perforated roller on which the paper web rests. The method of making these rollers is described so

consist of the following processes: a piece of sheet copper, brass, or other suitable metal, is bent and soldered in the form of a tube, whose length is equal to the circumference of the intended roller, and whose circumference is equal to the length of the intended roller, making an allowance for the waste at the ends. The tube is then to be drawn on treblets, in the usual manner, and afterwards turned truly cylindrical on the mandril, on which it was drawn. A series of grooves, eight or ten in number, are then turned half through the tube, with a tool the sixteenth of an inch wide, and so made as to make the bottoms of the tubes as wide as their tops. The tube is then taken from the mandril, cut open, and bent inside out, and soldered in the form of another tube, whose length shall correspond to the circumference of the first, thus constituting a hollow cylinder, with longitudinal grooves inside. It is to be again drawn, and turned with grooves to the amount of twenty-four in the inch; these will of course cross the other at right angles, and, being cut half through as before, the entire surface will be composed of transverse ridges and rectangular perforations. When it is desired to employ the exhausting principle, a second perforated cylinder is introduced within the first; the inner cylinder must be made smooth inside, that it may fit air-tight upon a sectoral cavity, extending from the axes to the circumference, enclosing about an eighth part thereof, opposite to the place covered by the web of paper, as it passes over the roller. The air is pumped from this cavity through the axis, which is made hollow for that purpose by an air-pump of the usual construction. When this method of abstracting the water is employed, the roller must be put in motion by a train of wheel-work, so arranged that it may coincide precisely with the motion through the machine.

1830. From a perusal of the specifications of patents granted about this period, it would appear, that the attention of the manufacturers of paper was rather directed to such improvements of the mechanism as were calculated to ameliorate and enhance the *quality*, than to such as might accelerate the process, and increase the *quantity*; and the ingenuity and talent thus called into action by rival manufacturers is deserving of record, were they of less practical utility. We shall therefore notice three of their inventions, in the order of the date of their patents. The first is Mr. Richard Ibotson's, of Stanwell, Middlesex.

Hitherto much difficulty has been experienced in clearing the stuff, or pulp, of which paper is made, of the small knots which are invariably found in it, and which, if not separated, necessarily deteriorate the quality of the paper. The sieves or strainers which have been generally employed for separating the knots, have been either so wide in the meshes as to permit the smaller knots to pass through, or else they very soon get clogged up; for it is evident that the fibres of which even the finest paper is made are considerably longer than one of the meshes in the sieve, and hence they will, instead of passing through, be deposited across the meshes, and immediately render the sieve useless. To remedy these imperfections, Mr. Ibotson manufactures his sieves or strainers (which he applies to the Fourdrinier machines) of metallic bars, giving the preference to gun-metal, made flat on the upper surface, and about half an inch wide, or, at all events, of a width greater than the length of any of the fibres in the pulp. The bars are strengthened by a projection extending along the middle of their lower sides, so that the cross section of one of the bars may be represented by the letter T. These bars are in a frame at a distance from each other, corresponding with the intended quality of the paper for which the sieve is to be used. He has designed, however, a very ingenious method of adjusting the distances between the bars, so as to make the same sieve answer for the manufacture of paper of different qualities: for this purpose he makes all the bars to taper uniformly, and fixes every alternate bar with its narrow end towards the same side of the sieve, and he frames the other bars together, but does not fix them to the sieve; they are introduced between the fixed bars, with their narrow ends in a contrary direction. By this arrangement, it is evident that the distances between may be diminished or increased to any degree of nicety, with the greatest facility, by pushing the frame of loose bars forwards or backwards, which is effected by means of adjusting screws. The sieve is to be placed in a

trough conveniently situated to receive the pulp from the hog, or machine by which the rags are torn to pieces, and agitated into the consistence of pulp. One side of the sieve, which is made in the form of a rectangular parallelogram, is attached by hinges to the trough, and the other is connected with a set of cam-wheels, by which it is elevated and depressed with great rapidity; and when the sieve gets clogged up by the knots, which it separates from the pulp, its surface is to be cleared by a rake or brush, made of hard bristles. This seems to be a highly ingenious invention; and, in the hands of a practical man, as it is, it cannot fail to become useful to the public.

The next patent, dated March 1831, is the invention of Mr. G. W. Turner, of Bermondsey, Surrey, which consists, first, in the construction of a new species of sieves for separating the lumps and coarse parts of the pulp from the finer portion, that the latter only be employed in the fabrication of the paper; and secondly, in a peculiar mode of applying the sieves, so as to supersede the use of, and form an improved substitute for the *vat* and the *hog*. Mr. Turner describes several forms of sieves in his specification, slightly varied, but partaking of the same characteristic features. That to which he appears to give a preference is of a circular form, and consists of a series of concentric rings of thin metal, previously bent into a right angle, but placed with a flat side upwards, like the letter L reversed, thus,  $\Gamma\Gamma\Gamma$ ; they are arranged in concentric circles, leaving between each annular crevices about the fiftieth of an inch wide, and are fastened by screws, or solder, to radial arms underneath, proceeding from a central block to a peripheral band, which is about 8 inches deep, and 3 feet in diameter. The manner in which the sieves are used we will now explain. Upon the top of a square vat or cistern is fixed a framed standard, supporting in plummer blocks, at its upper extremity, the axis of a vibrating beam; to each end of this beam is suspended, by a rod or spindle, one of the sieves just described, the bottoms of which lie, when at rest, upon the surface of the pulp in the vat. The rods, or spindles, are jointed to the beam, to allow of their moving vertically by its vibration, which is effected by a rod connected to a revolving crank, the latter imparting sufficient motion to the sieves to cause their bottoms to be alternately lifted out of the pulp an inch or two, and then plunged underneath it. To this action of the sieves is added that of a rotatory motion, communicated to them from the first mover by means of pulleys fixed on their rods or spindles, which pass through centre holes in the standard frame, and are provided with swivel joints between the links that connect them to the beam, and thus admits of a rotative as well as a vibratory action, at the same time, which tends to dislodge any gross particles that may stick in the interstices of the sieves, and, at the same time, to disturb and agitate the whole contents of the vat. The pulp, thus reduced to a smooth and homogeneous state, flows over a wide lip in the vat, directly on to the endless web or mould, and thus supersedes the necessity of the "hog."

In 1832 Mr. John Dickenson took out a patent for the same important object, that of obtaining a perfectly uniform and smooth pulp, in order that the paper produced therefrom might be of a firm and even texture; the process we proceed to describe, with reference to the figures on page 254. *a a a*, Fig. 1, represents a section of a vat containing the pulp, which is to be regulated by a waste; at *b* is a false bottom; *c c* is a rotatory cylinder, through which that portion only of the pulp that is to be made into paper passes; the knots, grit, &c. being prevented from entering by the wires which envelope the periphery of the cylinder. These wires are arranged spirally by a continuous coil, in the manner of a squirrel cage, but so close together as to leave only the one hundred and fifteenth part of an inch space between them. The wire recommended for this purpose is to be drawn of the figure represented in Fig. 2, the narrow underneath side *d* being fixed next to the cylinder, where it is to be fastened by rivets to the longitudinal bars *e e*, leaving the uniform space between the coils as before mentioned, which may, of course, be easily performed by a gauge. The spaces through which the pulp must pass are, therefore, longitudinal slits, two or three inches long, and only the one hundred and fifteenth part of an inch wide. The ends of the cylinder are closed, except at the axes of rotation, which are

formed of large tubes; through these the fine pulp received into the cylinder flows off to the mould on which the paper is formed. As there would be a continual liability of the fine interstices of the cylinders becoming clogged, unless some means were adopted to prevent it, Mr. Dickenson employs what is technically termed a float (though it does not possess that precise character), which, by an up-and-down motion, agitates the liquid, and, by changing the

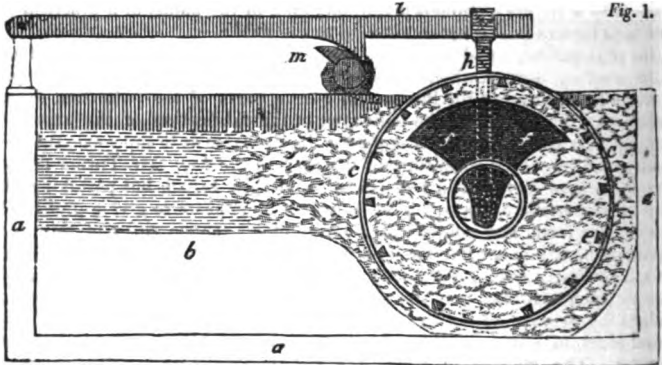
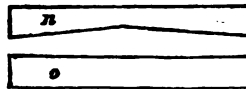


Fig. 2.



Fig. 3.



course of the current through the wires, throws off whatever has accumulated on the outside of them. This float is a close vessel of strong copper, of nearly the length of the cylinder (four feet), and of the sectional figure seen at *ff*; an horizontal bar passes throughout the lower part of this vessel, and also through the tubular axes of the cylinder, beyond the plummer boxes, in which the latter turn, where the horizontal bar is fastened to a vertical bar *h* at each end, that are connected to a lever *i*, whose fulcrum is at *k*. At *l* is a double cam, put in motion by a gear, in connexion with the wheel that actuates the rotatory cylinder; every revolution of the cam lifts the lever *i* twice by means of the wipers *m m*, and, through the medium of *h*, the copper float *ff* also, about 1½ inch each time; and the "float" being somewhat heavier than the fluid in which it is immersed, falls immediately afterwards, producing the required agitation. A second improvement under this patent, consists in the knives usually employed in the transverse cutting of the endless sheets of paper; these are usually two straight-edged blades, one of which being fixed, and the proper length of paper drawn over it, the other descends and divides the sheet by a similar action to that of shears. In lieu of the upper moving knife with a straight-edge, Mr. Dickenson employs one of an angular form, represented at *n*, Fig. 3, which is brought into contact with the lower fixed one, shown at *o*.

A patent for "certain improvements in *sizing, glazing, and beautifying* the materials employed in the manufacture of paper, pasteboard," &c., was taken out in 1828 by Messrs. De Soras and Wise; and as the process possesses novelty, and is in successful operation at the latter gentleman's mill at Maidstone, we annex the following particulars, which we have obtained by a perusal of the specification.—A ley is prepared with quicklime, the subcarbonate of soda (or potash), and water, in a vessel of white wood, until the alkaline solution shall be of 104° specific gravity, water being considered as 100°. With this solution a copper is to be about one-third filled, and heat applied, either by naked fire, or by steam; but the latter is, of course, preferable. There is now to be added of white bleached wax an equal weight to that of the solution, and the whole to be stirred until a

perfect union or solution of the wax is effected: if, after a boiling of three hours, this should not appear to be the case (which will easily be discerned after a little experience, and without waiting till the materials have become cold to determine the fact), then a little more of the alkaline ley may be added, by degrees, to complete the operation: this being done, and while the solution of wax is boiling hot, there is to be added more water, in the proportion of four gallons to every pound of wax in the solution, and the boiling continued. While this is going on, the starch of potatoes, in the proportion of from four to four and a half pounds to every pound of wax employed, is to be separately mixed in a gallon of water, and thrown into the copper, which, being stirred up, the whole contents of the vessel will almost instantly assume the consistency and colour of a very fine white paste, in which state it will keep good in summer for about fifteen days. The paste, prepared as above described, is to be used in the ordinary way of sizing paper, varying the quantity with the quality of the rags operated upon. If the rags be of the coarsest kind, about 3 lbs. of the pasty solution to 120 lbs. weight of rag in the pulp will suffice; if of middling fineness, about 4 lbs.; and if the very finest rags, about 5 lbs. of the paste. Previous, however, to the mixture being made into paper, a quantity of alum in solution, equal in weight to the wax employed, is to be mixed with it. The mixture is now ready to be made into paper, either by hand or by machines, in the usual manner. After the sheets are formed, it is advisable to dry them as speedily as possible by free exposure to the air, and not to hang more than two or three sheets upon one another, which should be parted before pressing. It is also recommended, that the felts used in the subsequent pressing of the new-made paper, be wetted in a weak solution of alum, and squeezed out by the press; and that the sheets of paper be two or three times alternately pressed and parted, by which process they will acquire a beautifully firm and glossy surface. The patentees likewise direct, that the couching felts be not washed out with soap, but with the ley, whenever required. Although the weight of the potatoe flour is given in the dry state, there is no occasion to dry it (which is a tedious operation), but employ it in the moist state, in which it deposits itself at the bottom of the vessels. Potatoe flour, in drying, loses 30 per cent. of water; which weight of water should be deducted in calculating the weight of flour employed. As several kinds of paper require only small quantities of sizing materials, those points must be regulated by the knowledge of the manufacturer.

The manufacture of stout and beautiful drawing-boards has occupied the especial attention of Mr. Steart, of De Montalt paper-mills, Coomb Down, near Bath, who received an honorary medal from the Society of Arts, Manufactures, and Commerce, for the communication of his process, which we have abridged as follows, from the *Transactions of the Society*.—The extra stout drawing papers, or card boards, as they are usually denominated, are always made by pasting several sheets of paper together in the manner of a common pasteboard, and afterwards bringing them to a smooth face, by pressing and rolling. The pasting is a dirty operation, and the occasion of many defects, some of which are fatal to the degrees of perfection and nicety required in a good drawing board. Another great defect is, that the far greater part of the drawing and writing papers now in use in this country, are of a hollow or spongy texture; this arises from their being made of an indiscriminate mixture of linen and cotton, the greater elasticity of the latter preventing its fibres from closely uniting with those of the wax; the consequence is, an irregular surface, and a porous, spongy substance, very different from that which an adherence to the good old-fashioned practice, of using fine linen rags only in the manufacture of superior papers, would produce. The lino-stereo tablet is entirely free from these objections for the following reasons:—first, it is not composed of several sheets pasted together, but is moulded from the pulp of any required thickness, in one entire mass; thus the risk of pasting is avoided, and no separation of the component parts can possibly take place, though wetted ever so often; secondly, instead of being composed of linen and cotton, it is wholly and solely manufactured from the best and purest white linen rags, most carefully selected, and,



consequently, without the aid of chloride of lime, or any bleaching process whatever.

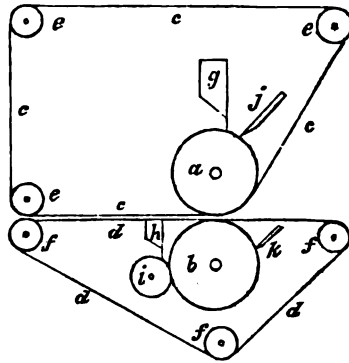
*The process.*—In selecting the raw materials for the manufacture of the lino-tablets, great care is taken to preserve the best and purest white linen rags only, rejecting all muslins, calicoes, and every other article made of cotton. The linen rags are then carefully sorted, overlooked and cleaned, washed, and beaten into pulp, in the usual manner practised by paper-makers of the first class. The pulp being ready, and diluted in the vat with the proper proportion of pure water, the workman, dipping his mould first into the vat, takes it up filled with pulp to the top of the deckle, and holding it horizontally, and gently shaking it, causes the water to subside, leaving the pulp very evenly set upon the face of the mould; having rested it for a moment or two upon the bridge of the vat, the compressor, with its face downwards, is now carefully laid upon the sheet or tablet, and both together placed in the small press close at hand, where it is submitted to a very gentle pressure, in order to exclude a great proportion of the water remaining in the sheet; it is then withdrawn; the compressor and the deckle are then both taken off, and another workman couches it by very dexterously turning the mould upside down, and pressing it pretty hard with his hands on one of the fine felts previously laid upon a very level pressing plank, by which means the tablet is left on the felt. The mould is then returned to the vat-man, who repeats the process as before: the coucher, in the mean time, lays another felt upon the sheet or tablet just couched, whereon the second sheet is to be laid in the same manner, and so on until all the felts are occupied; over which another level plank is placed, and the whole drawn away on a small rail-road waggon to the great press, where it undergoes a pretty severe pressure.

The tablets will now be found to have sufficient adhesion to bear handling with care, and are separated from the felts, and placed one upon another, so as to form the packs; these packs are to be submitted again to the action of the press, until more water is expelled; then are parted sheet by sheet, pressed and parted again; and this is repeated as often as is necessary, taking care to increase the pressure every operation, until the face of the tablets is sufficiently smooth; they are then carefully dried, sized, picked, sorted, &c.; carried to the rolling mill, and several times passed between the polished cylinders, to give them the last finish.

The above is the process for the plain or white tablets. In making the tinted tablets, the following additional particulars are to be attended to. The rags are cleansed, washed, and beaten into half stuff, in the usual way; the water being drained off, the pulp is put into a vat with a solution in water of acetate of alumine, or sulphate of iron, as a mordant or ground to fix the colour intended to be made; the whole is well incorporated, and suffered to remain for half an hour or more, when the colouring tincture, previously prepared, is added; after which, the whole being returned to the engines, is beaten into fine pulp, and then wrought into fine tablets. The dyeing materials chiefly made use of by Mr. Steart, are, mangrove bark, quercitron bark, best blue Aleppo galls, sulphate of iron, and acetate of alumine. A due combination of these materials produce a great variety of drabs, greys, sand-colours, &c.

An apparatus and process for sizing paper in a more effectual manner than it had previously been done, was recently patented by Mr. Towgood, of Dartford, in conjunction with Mr. L. Smith, of Paternoster-row, London. This invention consists in the application of *pressure* along with the *size*; which is effected by depositing on the surface of a pair of pressure rollers, or on one of them, if the paper be required to be sized only on one side, a thin uniform film of size, which is pressed into the paper as it passes between the rollers. An endless felt is sometimes made to pass over each of the rollers, and in that case the size will be forced through the felt to the paper. This sizing apparatus may be applied either separately, or in combination with a paper machine of any construction; but the form and arrangement of the different applications will necessarily vary with the form of the machinery to which it is applied. The form represented in the following diagram will be sufficiently explanatory.

*a b* represent two pressure rollers, with pieces of endless felts *c c c*, and *d d d* passing around them, being supported and guided by a series of friction rollers *eee* and *fff*; *g* is a small trough with a perforated bottom for supplying the surface on the surface of the pressure roller *a*; and *h* is a similar trough for supplying size to the roller *i*, which transfers its supply to the other pressure roller *b*; and *jj* are two scrapers for keeping clean the surfaces of the pressure rollers.



The cutting of paper into sheets of any required dimensions as exactly and expeditiously as possible, is an object of great importance to the manufacturer; and as the machine-made paper is of considerable greater width than is required, it becomes necessary to cut it lengthwise. The following is the patented method adopted by Mr. Crompton, of Tamworth, in Lancashire, and Mr. Taylor, of Marsden, in Yorkshire, according to their enrolled specification, dated 1828. *Fig. 1* is a side elevation of the machine; *Fig. 2* a plan of the cutters. *a* is the roller upon which the paper (either in the moist state in which it is delivered from the felts when freshly made, or when dry,) is rolled; *b b* and *c c* are two pairs of drawing rollers, which conduct the paper first between the circular cutters

Fig. 2.

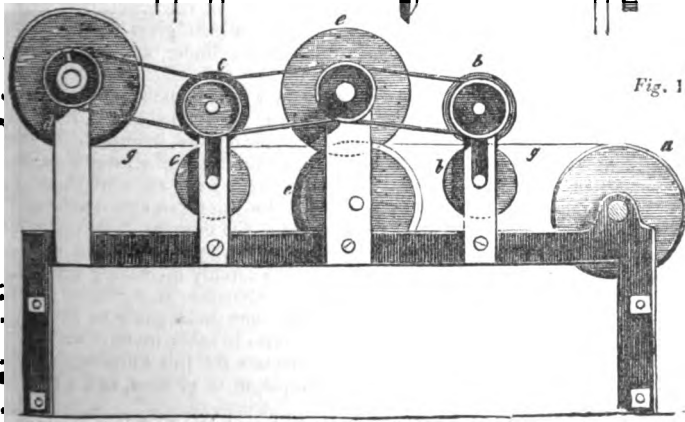
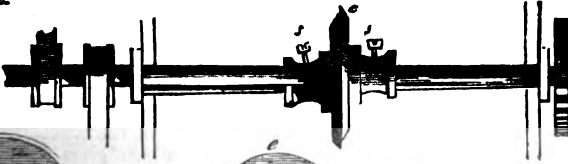


Fig. 1.

*ee*, and thence on to the roller *d*, where it is wound in its divided state. The shaft upon which the upper cutter is fixed, is driven by any prime mover; and by means of endless bands and pulleys it imparts motion to the upper drawing rollers *b* and *c*; these two upper rollers turn the two lower, by means of cog-wheels at the other extremities of their axes, which gear into each other; the



upper cutter has in like manner a toothed wheel upon its axis, which turns another toothed wheel upon the axis of the lower; none of these toothed wheels are brought into view in the drawing, to prevent confusion. By the revolutions of these parts of the apparatus, the paper, represented by a line *gg*, is drawn from *a* between the rollers *b*, is severed at *e*, and thence is carried by the rollers *c* on to *d*, by means of an endless band from the latter, as shown. In order to accommodate this movement to the increasing circumference of the roller *d*, occasioned by the paper accumulating upon it, the band pulley on *d* is a friction roller, which is set so as to allow of its slipping a little in its revolutions. It should also be noticed, that the axis of the lower cutter is not quite parallel to the axis of the upper one, by which means the edges of the cutters facing the rollers *a* are brought into contact, whilst the other edges diverge, which causes the paper to be more freely delivered from the cutters. The great rapidity of this process of cutting is evident.

Another method of cutting paper of great merit was patented by Mr. Edward Newman Fourdrinier, paper maker, of Hanley, in Staffordshire. It consists of a series of receiving rollers placed one over the other. The several webs of paper to be cut pass over these, are then brought together, and passed over the collecting roller equally distant from the others; and thence, by the aid of an endless felt or blanket which passes about a series of guide rollers, they are conveyed under the main cylinder of the machine, and delivered to the cutter at the opposite side to which they entered. The cutter consists of a machine which acts on the principle of shears; the lower blade being fixed, and the upper attached to an arm which vibrates upon a centre, and placed to meet the stationary blade at an appropriate angle, so as to produce the best clipping action. When a sufficient quantity of the paper has passed over the lower blade to constitute the length of a sheet, the upper blade begins to descend; but previously to the blades coming into contact, a holder, consisting of a bar extending the whole width of the paper connected with the same vibrating arm, is made to press down and hold the paper firm on the lower blade, while the cutting is performed. During the operation of cutting, the main cylinder, as well as the guide rollers, remain stationary, while an actuating rod returns to bring another length of paper. This vibrating rod gives motion to a sector, which has on its upper side ratched teeth, that are acted upon by the rod as it moves in the direction from right to left, but which remain stationary while the rod moves in the contrary direction. The sizes of the sheets cut by this machine are regulated by an expanding crank, which gives motion to the actuating rod, and through that means to the main cylinder, and other parts of the apparatus.

A great many materials as substitutes for rags in the manufacture of paper have been at different times proposed; the bark of the willow, beech, hawthorn, and lime, the stalks of the nettle and thistle, the bine of hops, indeed almost every vegetable substance capable of yielding easily an abundance of strong fibre, have been suggested, and excellent paper has been made from some of them; but the introduction of the bleaching process, and the improvements made in the mechanism for forming the pulp, having enabled the coarsest linen and cotton fabrics to be brought into use, the supply of rags is at present found equal to the demand for paper, immense as that is. The rapidly increasing knowledge of the people in most parts of the world will probably create an increased demand for books, and the stock of rags may again become inadequate to supply the paper manufacturer, who must again have recourse to other materials: we propose therefore to describe three patented processes for this purpose; namely, one for making it of *straw*, another for the employment of *moss*, and a third for the use of *solid wood*.

Mr. Lambert's process for making paper of straw is as follows:—Having collected a quantity of straw, all the joints or knots are to be cut away, and the remainder boiled with quicklime in water, for separating the fibres, and extracting the mucilage and colouring matters. (Instead of quicklime in this part of the process, caustic, potash, soda, or ammonia, may be employed.) It is then to be washed in clear water to get rid of the colouring matter and lime,

and afterwards subjected to the action of an hydro-sulphuret, composed of one pound of quicklime, and a quarter of a pound of sulphur to every gallon of water, for the more effectual removing of the mucilaginous and silicious matters. After this, the material is to undergo several successive washings in different waters, to get rid of the alkaline and other extraneous matters, which may be conveniently effected by beating in the ordinary paper-mill. When no smell of sulphur is left, the water is to be squeezed from the fibrous material by mechanical pressure, and then to be bleached by chlorine, by exposure on a grass-plot, or any other convenient and well-known means: it is then to be washed again, to get rid of the bleaching ingredients, next to be reduced to pulp by the common apparatus for the purpose in a paper mill, and then moulded into sheets. The subsequent operations are, in other respects, similar to paper made from the usual substances.

*Moss Paper.*—Mr. Nesbit, of Upper Thames-street, had a patent in 1823 for the fabrication of a coarse kind of paper, especially applicable to the sheathing of ships, in the manner that the tarred brown paper is usually applied. The material is a peculiarly soft kind of moss, which grows abundantly in the ditches and low grounds of Holland. In that country, and in several of the northern states of Germany, paper made from this material is employed as a covering to the bottoms of ships, between the wood and copper sheathing, and is found to be peculiarly serviceable in preventing leaks; owing to its absorbent quality it swells up, making a close and firm packing under the copper. The manufacture of paper from this substance is exceedingly simple. The moss is first to have the adhering earth washed from it, then to be chopped in short pieces (about half an inch long) in a similar machine to a tobacco cutting-mill; after this it is to be soaked for several hours in water, then formed into sheets in the ordinary way between moulds, placing each sheet between woollen cloths; in this state they are to be subjected to mechanical pressure, afterwards thoroughly dried, and lastly, pressed again between sheets of brown paper, (placed alternately,) when the manufacture is completed.

*Paper from Wood.*—This process is the subject of a patent lately granted in the United States. The shavings of wood are to be boiled in water, with from 12 to 18 parts, by weight, of common alkali, which reduces the wood to a mass of fibres, adapted for conversion into paper by the ordinary means. One hundred pounds of wood, the patentees state, will make from five to seven reams of paper.

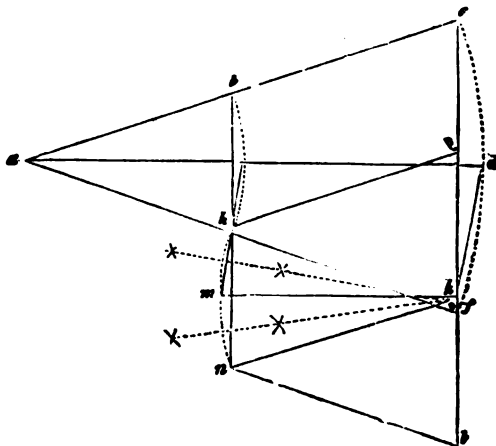
*Ivory Paper* is described under the word *IVORY*. Paper hangings being made of ordinary paper, subsequently stained or printed, are noticed under the head *STAINING*.

**PAPIER-MACHE.** A name given by the French to an artificial substance, applied to many useful and elegant purposes. It is made of the waste cuttings of paper, boiled in water, and beaten to a pulp in a mortar. It is afterwards mixed with size to give tenacity to the paste, and when brought to the proper consistency it is pressed in moulds of an infinite variety of forms; and thus made into tea-boards, trays, snuff-boxes, &c., which are afterwards coated with pigments, varnished and ornamented.

**PARAGRANDINE.** A new invention, the object of which is to avert hail-storms, acting in the same manner as the electric conductors for obviating danger from lightning. In this climate the hail is seldom so violent as to occasion any very serious losses; but in many parts of the continent it is dreaded as the most destructive enemy of the husbandman, and has given rise to the establishment of insurance companies, to compensate the sufferers. The inventor of the paragrandine is a Signor Apostolla. One of the latest accounts of its beneficial effects was published by Antonio Perotti, who states, that having, on a piece of land belonging to himself, containing 16,000 perchs in extent, fixed up several of the paragrandines, he had the satisfaction to find that no injury was done by hail to the corn, and very little to the vines, although no less than fourteen storms had occurred in the current year, five of which appeared to threaten great mischief to his fields, but passed over them, and fell on the neighbouring lands. These instruments are composed of metallic points and straw ropes, bound together with hempen or flaxen threads. Dr. Astolfi relates that in a hail-storm the

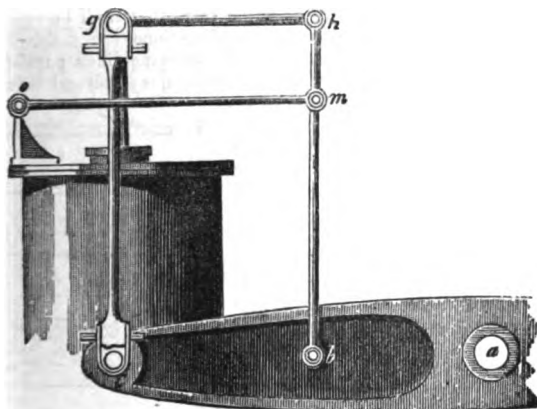
clouds were seen to disperse on passing over lands protected by paragrains. A notice contained in an official report to the Milan government by the Gonfaloniere of St. Pietro, in Casale, also states, that during a stormy day, when there were many claps of thunder and flashes of lightning, he went out to observe the effects of the paragraine, and noticed that the electric fluid was attracted by the points of straw in the apparatus, around which the flame played in graceful curves; while in the adjoining field, not protected by the paragraine, much rain fell, and the lightning did considerable mischief. We have thought it proper to introduce this notice of a foreign invention, as it appears to be capable of beneficial application in this country in the protection of agricultural produce collected in stack-yards.

**PARALLEL MOTION.** A term applied by practical machinists to an arrangement of parallel bars, by which the alternating rectilinear motion of a piston rod is made to work harmoniously with the alternating curvilinear motion of a rocking beam. As the beam of all engines vibrates upon a centre, of course it performs portions of a circle with each of its extremities; and as the rod of a piston is required to move up and down in a straight line, it cannot be immediately attached to the end of the beam; hence the necessity of the intervening mechanism called the parallel motion. There are many methods of effecting this motion in general use; and ingenuity may devise many more of equal or superior merit. In single engines of the old construction, where the action was a *pull* at both ends of the beam (at the one end by the weight of the pump rod, and, at the other, by the downstroke of the piston), a chain was affixed to the upper part of the curved ends of the beam, and to the pump and piston rods, which answered the purpose very well, and is still much used for similar purposes; but in double acting engines, where the piston rod *pushes* upward, as well as *pulls* downward, some other mode of action is required. The first plan employed by Bolton and Watt was to place a toothed sector on the end of the beam, the length of the radius being equal to the distance between the axis of the beam, and a vertical line passing through the centre of the piston rod; and on the upper part of the piston rod was placed a rack, which acted upon the sector, and forming a tangent to it, preserved the rectilinear motion of the piston rod throughout the stroke. A much superior method of effecting this was afterwards devised, to which the name of parallel motion more justly belongs; it consisted of an arrangement of parallel rods moving on circular axes, the principle of which may be thus briefly explained:—If a bar be so confined by other bars that the motion of the end *a*, in a right line, causes the



other end *b* to describe a certain curve, it follows, on the other hand, the motion of *b* in the curve will cause *a* to describe a right line. To apply this to the case

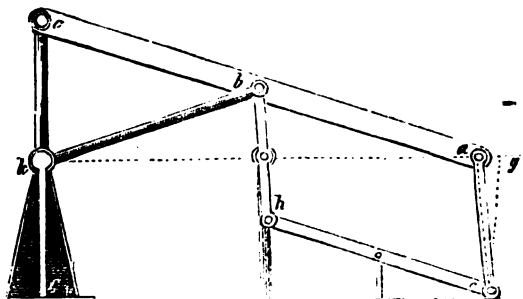
before us, let  $abc$  represent the beam of an engine at the highest point of the stroke;  $ad$  its position at the middle of the stroke; and  $af$  its lowest position:  $cg$  and  $bh$  are two side rods, suspending the bar  $gh$ , parallel to  $abc$ ;  $gkl$  a right line, in which the bar  $g$  moves in a groove; then, when the end of the beam  $c$  is at  $d$ , the end  $g$  of the bar  $gh$  will be at  $k$ ; and as  $gh$  is parallel to  $ad$ , the other end  $h$  of the bar  $gh$  will be at  $m$ ; and when  $c$  arrives at  $f$ ,  $g$  will be at  $l$ , and  $h$  at  $n$ ; the point  $h$ , therefore, will have described a curve, in a right line, passed through the points  $gkl$ ; if, therefore, the groove in which the head of the piston-rod moved be taken away, and the end  $h$  of the bar  $gh$  be joined to a radius bar, describing a circular arc passing through the points  $kmn$ , then the end  $g$ , of  $gh$ , to which the piston rod is attached, will move through the points  $gkl$ , and the whole path of the piston rod will differ very little from a right line. The small deviation from a right line arises from the circumstance, that the curve described by the end  $h$  is not exactly a circular arc when  $g$  moves in a strictly right line. To find the length and centre of motion of the radius bar with any distance in the compasses, and on the points  $kmn$ , describe arcs intersecting each other; and through the points of intersection draw lines cutting in  $o$ ; then  $os$  will be the length of the radius bar, and  $o$  its centre of motion.



The parallel motion in general use in steam-boats is represented in the foregoing diagram. The length of the radius bar and the centre of motion may easily be found, as in the former case, by supposing the piston rod to move in a right line, and finding three points, through which a point in the side rod (assumed at pleasure) would pass in the highest, lowest, and middle position of the piston rod; then a circle, which passes through these points, will give the radius and centre sought; and the point assumed in the side bar will be the point for its connexion with the radius bar.  $abc$ , part of the beam;  $cg$  and  $bh$  side rods;  $g$  the point of junction of the piston to the side rod  $cg$ ; and  $m$   $o$  the radius bar.

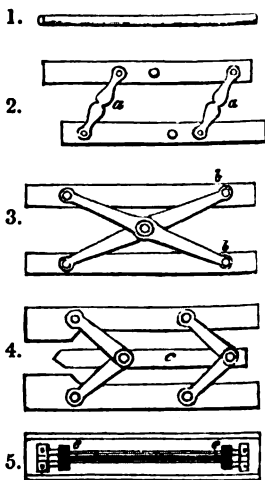
In portable engines without a beam, the cross on the head of the piston rod has usually on its ends friction wheels running between guides; but we prefer the parallel motion introduced in Lloyd's portable engine, described hereafter, as it affords a convenient method of working the air pump and cold water pump. The principle of the parallel motion in this engine will be understood by reference to the following diagram.  $abc$  represent a bar corresponding to half the beam of an engine,  $ckf$  the path of the piston rod, and  $bk$  the radius rod; now the radius rod, and the two portions of the beam  $ab$ , and  $bc$  being respectively equal, if  $a$  move in a right line towards  $g$ ,  $c$  will move in the line  $ck$ , and if  $a$  be connected to a rocking bar  $ae$ , which, from its length, or its small angular motion, describes an arc  $ga$ , differing but little from a right

line; and a side bar or strap  $b h$ , and the parallel bar  $h e$  being added, the centre of  $b h$  will be the point of suspension for the rod of the air pump, and the rod of the cold water pump may be suspended from the parallel bar  $h e$ .



**PARALLELOGRAM OF FORCES.** A term used to denote the composition of forces, or the finding of a single force that shall be equivalent to two or more given forces when acting in given directions.

**PARALLEL RULER.** An instrument for drawing lines parallel to each other. The simplest parallel ruler is the common cylindrical ruler of the counting-house, represented at *Fig. 1*; it serves very well for common purposes, where great exactness is not required. *Fig. 2* is the common parallel ruler, consisting of two flat rulers connected together by two small brass levers jointed at their extremities; the mode of using this instrument is too obvious and too well known to need explanation. An objection to the latter, of the bar moving circularly sideways, is obviated in the instrument represented at *Fig. 3*; the bars in these being crossed and connected at the point of intersection by a joint, and two of the ends sliding in grooves, as seen at  $b b$ , causes the rulers to move uniformly straight, or at right angles with their length. *Fig. 4* exhibits another arrangement in use, whereby a similar rectilinear motion is produced by two pair of short bars, connected to an intermediate slip  $c$ , which, when the ruler is closed up, exactly fill up the cavity between the pieces on either side. *Fig. 5* represents another parallel ruler of great convenience and utility. It is usually made of black ebony, with slips of ivory at the edges, divided into inches and parts; a hole is cut through the ruler at  $e e$ , in which revolve two little brass wheels, projecting about an eighth of an inch from the under surface, and upon which the ruler is rolled, steadily held in the middle by the left hand, whilst the draughtsman draws the lines with his right. The brass wheels are fixed to a steel spindle, which turns in brass bearings at its extremities; between each bearing and brass wheel there is a little ivory cylinder, divided into equal parts, which revolves with the latter, and shows precisely the quantity of motion in the ruler, and thus enables the draughtsman to draw his lines at equal or any desired varying distances apart. The steel spindles in the more recently constructed rulers are cased over with ebony, which renders them more convenient as well as more durable.



**PARBUCKLE.** A term given to a contrivance whereby a cask, &c. is

raised or lowered without a crane or pulley tackle; it is formed by passing the middle of a rope round a post or ring, or under a boat's thwart; the two parts of the rope are then passed under the two quarters of the cask, bringing the two ends back again over it, which, being both hauled or slackened together, either raise or lower the barrel, &c., as may be required.

**PARCHMENT.** A durable material, prepared from the skins of sheep and goats, but chiefly the former, and employed for writing upon, the covers of books, and various other purposes. The skin is stripped of its wool, and passed through the lime-pit. The skinner then stretches it on a frame, perforated longitudinally with holes furnished with wooden pins, that may be turned at pleasure, like those of a violin, to stretch the skin like a drum-head. The skin being thus sufficiently stretched on the frame, the flesh is pared off with a sharp instrument; it is then moistened with a rag, and white chalk, reduced to a fine dust, strewed over it; then, with a large pumice-stone, the workman rubs over the skin, and thus scours off the remains of the flesh. They then go over it again with an iron instrument, moisten it as before, and rub underneath with pumice-stone, without any chalk; this smooths and softens the flesh side very considerably. They drain it again by passing over it the iron instrument as before. The flesh side thus drained, they pass the iron on the hair side, then stretch it tight on the frame by means of the pins, and go over the flesh side again with the iron; this finishes its draining: the more the skin is drained the whiter it becomes. They now throw on more chalk, sweeping it over with a piece of lamb-skin that has the wool on; this smooths it further. When dried it is taken off the frame by cutting all round. The skin thus far prepared by the skinner, is taken by the parchment-maker, who first scrapes or pares it dry on the summer (which is a calf-skin stretched in a frame) with an iron instrument like that above mentioned, only finer and sharper; with this, worked with the arm from the top to the bottom of the skin, he takes away one-half of its thickness; and the skin thus equally pared on both sides, is rubbed with the pumice-stone to smooth it. This last preparation is performed on a bench, covered with a sack stuffed with flocks, and it leaves the parchment fit for writing upon. Vellum made from the skin of sucking-calves possesses a finer grain than parchment, but prepared in the same manner without being passed through alum water.

**PARTING**, in Metallurgy, is an operation by which gold and silver are separated from each other. In this sense it is the same with refining metals, or obtaining them in a pure state. Gold and silver are called perfect metals, because they are capable of withstanding the action of very strong heat. All other metals are reduced to the state of oxides when subject to fire with access of air. Gold and silver may, therefore, be purified from baser metals by keeping them melted till the alloy be destroyed; but this process is tedious and expensive, from the great consumption of fuel. A shorter and more advantageous method of refining gold and silver has been discovered. A certain quantity of lead is put into the crucible with the alloy of gold and silver, the whole is exposed to the action of the fire; and the lead being quickly converted by heat into an oxide, which is easily melted into a semi-vitrified and powerful vitrifying matter, called litharge, we have only to increase the proportion of imperfect metals; and, by uniting with these imperfect metals, it communicates to them its property of being very easily oxidated. By its vitrifying and fusing property, exercised with force upon the calcined and naturally refractory parts of the other metals, it accelerates the fusion, scorification, and separation of these metals. In this operation the lead is scorified, and scorifies along with it the imperfect metals. It separates from the metallic mass, floats upon the surface of the melted mass, and becomes vitrified; but as the litharge would soon cover the melted metal, and, by preventing the access of air, prevent the oxidation of the remaining imperfect metals, such vessels are employed as are capable of imbibing and absorbing in their pores the melted litharge, and thus removing it out of the way; or, for large quantities, vessels are so constructed that the fused litharge, besides being soaked in, may also drain off through a channel made in the corner of the vessel. Vessels made of lixiviated wood, or bone ashes, are most

proper for this purpose. These vessels are called *cupels*, the process itself *cupellation*. The cupels are flat and shallow. The furnace should be vaulted that the heat may be reverberated upon the surface of the metal during the operation. A crust or dark-coloured pellicle is continually forming upon the surface. When all the imperfect metal is destroyed, and the scorification has ceased, the surface of the perfect metal is seen clean and brilliant, forming a kind of fulguration called lightning. By this mark the metal is known to be refined.

**PASTE.** Glass prepared in imitation of gems. The basis of all artificial gems is a very hard and pure silica, obtained by melting pounded quartz with an alkali, with the addition of borax, nitre, and different metallic oxides, according to the intended colour of the gem. The materials should be of the purest kind, finely pulverized, well sifted, melted in crucibles of the best quality, and the fusion should be continued in a potter's furnace for twenty-four hours; the more tranquil and continued it is, the denser the paste, and the greater its beauty. The following are the ingredients, with their proportions, employed in the formation of some of the artificial gems. For what is called simply paste or strass, there are four different mixtures.

PASTES.	1.	2.	3.	4.
Rock crystal . . . . .	·318	·3170	·300	
Minium . . . . .	·490	·4855	·565	
Pure potash. . . . .	·170	·1770	·105	·054
Borax. . . . .	·021	·0200	·030	
Oxide of arsenic . . . . .	·001	·0005		
Litharge. . . . .				·540
Ceruse . . . . .				·408
	<u>1·000</u>	<u>1·0000</u>	<u>1·000</u>	<u>1·000</u>

For *topaz*, there are the two following methods:—

	FIRST.	SECOND.
Strass, (white paste). . . . .	·95816	·990
Glass of antimony . . . . .	·04089	
Purple of cassius . . . . .	·00095	
Oxide of iron . . . . .		·10
	<u>1·00000</u>	<u>1·000</u>

For <i>ruby</i> strass. . . . .	·9755
Oxide of manganese . . . . .	·0245
	<u>1·0000</u>

For *emerald*,—

Strass, (white paste). . . . .	·98743	·9905
Green oxide of copper . . . . .	·01200	
Acetate of copper . . . . .		·0080
Oxide of chromium . . . . .	·00057	
Peroxide of iron . . . . .		·0016
	<u>1·00000</u>	<u>1·0000</u>

For *sapphire*,—

Very white strass. . . . .	·9855
Oxide of cobalt . . . . .	·0145
	<u>1·0000</u>

	FIRST.	SECOND.
<i>For amethyst,</i>		
Strass . . . . .	·9870	.9979
Oxide of manganese . . . . .	·0078	·0023
Oxide of cobalt . . . . .	·0050	·0001
Purple of Cassius . . . . .	·0002	
	<u>1·0000</u>	<u>1·0000</u>
<i>For beryl, or aquamarine,</i>		
Strass . . . . .	·9926	
Glass of antimony . . . . .	·0070	
Oxide of cobalt . . . . .	·0004	
	<u>1·0000</u>	
<i>For Syrian garnet,</i>		
Strass . . . . .	·6630	
Glass of antimony . . . . .	·3320	
Purple of Cassius . . . . .	·0025	
Oxide of manganese . . . . .	·0025	
	<u>1·0000</u>	

**PASTE.** A mucilaginous preparation of wheaten flour, incorporated with water by boiling. Sometimes powdered resin is mixed with it; also gum arabic, size, &c., according to the peculiar wants of the artist or manufacturer. Alum is also considered to increase its cementing property.

**PASTEBOARD.** A thick kind of paper, made by pasting several sheets together, which are afterwards pressed or rolled, to give the fabric firmness and evenness of surface.

**PASTIL.** A dry composition of odoriferous resinous matters, commonly employed to burn in chambers, to sweeten the air.

**PATENT**, or *Letters Patent*, is a writ or grant in the king's name, and under the great seal, designed to secure to the proprietor of any new invention the monopoly of its advantages for the term of fourteen years; but this term is sometimes extended, under extraordinary circumstances, by act of Parliament, to a longer period. The term patent is also applied to the right conveyed, as well as to the instrument conveying it. Monopolies, unless granted for a limited period, and with the view to the ultimate benefit of the public. During the reign of Elizabeth, many unmerited monopolies had been granted, which had so prejudicial an effect upon the commerce of the country, that, towards the end of that monarch's reign, the clamour was so loud and general as to induce her to send a message to Parliament, announcing her intention to immediately cancel the most oppressive of the exclusive privileges she had granted. But however just may be the feelings of opposition to monopolies in general, it will be readily allowed, that a patent for a new invention, for a few years, is only a just and reasonable compensation to the inventor, who is thus enabled to mature his discovery, and give it to the public, at the termination of his monopoly, in a perfect or highly improved state. And were it not for the exclusive privilege thus granted, many important inventions, that ultimately prove beneficial to the public, would never be persisted in, but entirely fail; as that powerful incentive would have no existence, which induces ingenious men to study and labour incessantly, and to expend large sums of money to bring their inventions into practical operation.

The basis of the present law of patents is derived from the 21st of James I., ch. 3, which is regarded as the declaration statute; and the sixth section of this statute states, that patents for new inventions are exceptions to the general law of the statute. The general law is, that all monopolies, and all commissions, grants, licenses, letters patent, &c. for the sole buying, selling, making, using, &c. of any thing, shall be void; the excepting clause declares, that "any declaration before mentioned shall not extend to any letters patent, and grants of privilege, for the term of fourteen years or under, hereafter to be made, of the sole working and making of any manner of new manufacture within this





realm, to the true and first inventor or inventors of such manufactures, which others, at the time of making such letters patent and grants, shall not use, so as also they be not contrary to law, nor mischievous to the state, by raising the prices of commodities at home, or hurt of trade, or generally inconvenient."

The great importance of the subject of patents to engineers, machinists, and manufacturers in general, renders it desirable to extend this article to an account of the process of obtaining a patent; also the nature and conditions of the grant, and the expenses attending it; which information the writer of this article and compiler of the work is enabled to afford with perfect accuracy, he being professionally a patent agent. It is by no means necessary that the applicant for a patent should employ an agent,—he may solicit the grant himself; there are, however, but few persons whose experience and knowledge of the matter sufficiently qualifies them to transact the business of a patent with security to their own interests.

The first thing an inventor should attend to, is to endeavour to ascertain if he has not been anticipated by others, which is not an unfrequent occurrence, although rarely discovered until too late to benefit by it; owing, perhaps, to the injudicious flattery of friends, or the ignorance of legal advisers in matters of invention or discovery. Having determined the invention to be entirely original, and that it is calculated to compensate him for the expenses of a patent, the inventor's first step to obtain one, is to make an affidavit of the fact of his invention before a Master in Chancery, if in London, or if in the country, before Master Extraordinary, in the following form; the words in italics being assumed to afford precise examples.

(FORM.)

*"John Smith, of Birmingham, in the county of Warwick, Iron Founder, maketh oath, and saith, that he hath invented 'certain improved forms of apparatus for the transmission and distribution of heat, the generation of vapours, and other processes,' which he believes will be of public utility; that he is the first and true inventor thereof; that the said invention is entirely new, having never been practised nor used by any other person or persons, to the best of his knowledge and belief.*

(Signed)

"JOHN SMITH.

*"Sworn at the Public Office in Southampton Buildings, this 6th day of March, 1834, before me,*

"H. CROSS."

Before, however, the affidavit is made or acted upon, the inventor should well consider the nature and words of the title or designation of his invention, for many patents have been annulled owing to the improper wording of the title. The law requires, that it shall form a true index to the specification; yet if it be so clear as to call the attention of rivals, and enable them to discover the secret of the invention, before the patent has passed the great seal, the patentee may lose his privilege as well as his money. If, on the other hand, the title should be so obscure as to incur the danger of a court of justice afterwards ruling that it is an imperfect definition of the invention, he will also forfeit his privilege. Lord Cochrane was thus most arbitrarily deprived of his patent right for the admirable street lamp which bears his name, owing to his having entitled the patent an "improved method of lighting cities, towns, villages." Now when it is considered that no security whatever is afforded to the applicant until his patent has passed the great seal, and that he is, during this period, by too explicit a title, liable to be robbed of his right by impostors, the harshness and injustice of the decision just mentioned becomes very apparent. Latterly, however, the judges have been somewhat more tender of the rights of patentees, to which improved conduct the writer perhaps indirectly contributed. He was opposed, during the passing of a patent for some gentleman, on the ground of the studied obscurity of the title, and he was required to render it more explicit; this, however, he declined doing, as a compliance would be equivalent, in effect, to a publication of the specification, as it was for one of those simple discoveries in which a word more of explanation would have exposed the object to those from whom it should be kept secret. This fact he satisfactorily proved to the Solicitor General, who admitted the necessity of the course taken, and the opposition

was defeated. It was at the same time respectfully intimated to the Solicitor General, that if any additional information in the title were insisted upon, the patent would be declined altogether, and the intended manufacture be removed to France, where security against piracy would be afforded at the instant of lodging a petition. The case mentioned is, however, an extreme one, and of rare occurrence; in most cases there is no difficulty whatever, though prudence dictates, that so important a step as the proper definition of an invention, on which the patent-right is founded, should be well considered.

The next step is to draw up a petition to the king, which contains a reiteration of the affidavit, and prays for the grant of the patent "for the term of fourteen years, according to the statute in that case made and provided." Here it becomes necessary to explain that patents for England, Ireland, and Scotland, are entirely separate and distinct from each other; and that when it is required to extend the grant to the British possessions abroad, the latter are included under the patent for England, at the additional cost of about five pounds. Supposing the application be for England alone, the prayer of the petition is expressed for "England, Wales, and the town of Berwick-upon-Tweed;" and should the Colonies be desired (which is rarely advisable), it is only necessary to add to the words just quoted, "and all your Majesty's Colonies and Plantations abroad." The petition, with the affidavit, is lodged at the office of the Secretary of State for the home department, for the king's pleasure, who directs, or rather is presumed to direct, the Secretary of State to refer the matter to the Attorney or Solicitor General for his advice thereon; the petition is, accordingly, endorsed with such reference, and signed by the Secretary of State, and, upon the payment of the fees, delivered to the applicant, who uses his discretion as to whether he had best take it to the Attorney or Solicitor General, being guided in his decision by the probability as to which of the two will execute the business with the least delay, and in the manner most satisfactory to the applicant. Upon receipt of the king's reference at either of the before-mentioned legal functionaries, the clerk examines the caveat book, to ascertain whether there be any existing caveats against the granting of a patent for a similar object to that expressed in the applicant's petition. If there be none, the clerk takes the earliest opportunity of drawing out the *report* in the usual form, to be ready for the examination and signature of his principal. The report thus completed, is, upon payment of the fees, delivered to the applicant, who transmits it to the king, through the medium of the Secretary of State's office. Before attending to what is done with it there, it is proper to notice the proceedings that would be taken in the case of there being interfering caveats;—and we may observe, by the way, that there are always numerous caveats against such inventions being patented as that expressed in the example of the affidavit we have furnished. Under these circumstances, the Attorney General's clerk (whose office, we will suppose, we have entered by preference,) writes a circular letter to each of the caveatees, informing them of the application, and adding this injunction,—“Should you consider the above to interfere with your caveat of [mentioning the date], an answer, post-paid, is requested within seven days of the date hereof, otherwise the patent will proceed.” When the seven days have expired, and none have thought proper to answer, the applicant is entitled to his report; but should any answer, or “oppose,” as it is called, such opposer must deposit with the Attorney General's clerk a sum equivalent to the expense of the hearing and the summonses (generally under five pounds). The Attorney General afterwards appoints a day when he will hear the rival inventors, or their agents, (and to these are sometimes added counsel, who are, however, generally only an incumbrance in nice points relating to practical mechanics,) and each of these is summoned for the appointed day. When met together, the Attorney General first calls in the applicant, or his agent, who explains to him alone, and confidentially, the nature of his invention, and the leading points upon which he rests his claim of originality. The caveatee, or caveatees, are next heard in privacy; and if the Attorney General cannot make up his mind upon the first hearing, the rival parties are called in again alternately, and re-examined until he is satisfied. If he finds the inventions to be essentially alike, he refuses the patent to either

individually, but offers them a joint patent, if they will unite their interests in one this recommendation, though rarely, has been sometimes adopted, and attended with advantageous results. In the case of the inventions being essentially different, the opponent is told so, and the applicant receives his report. A few days after this report has been delivered to the Secretary of State, a royal warrant is prepared, which is signed by the king. This warrant, which recites the prayer of the petition, the legal advice given to His Majesty, and other matters of form, concluding with directions to the Attorney General to prepare a bill for His Majesty's signature, is taken to the Bill-office (an office exclusively appropriated to the engrossing of patent bills, under the superintendence of the Attorney General,) where it is prepared in the course of a few days, or a week, and then delivered to the applicant, who takes it to the Secretary of State, to obtain the king's signature (to it. The king having signed it, it is called the "King's-bill," and is next taken to the Signet-office, which, having passed, it is denominated the "Signet-bill." Hence it is conducted into the Privy Seal-office, where, having received the privy seal, it is baptized the "Privy Seal-bill," and is conducted to the Great Seal-office to receive the great seal, or finishing stroke. Formerly it had a more tortuous course of manufacture, having to go through a process at the Hanaper-office; but although this one of the many absurdities has been got rid of, the hanaper fees are still extorted, being made payable at the Great Seal-office before the patent can be obtained. We should here notice, that caveats are sometimes entered at the Great Seal-office; but opposition made by virtue of them, to the sealing of a patent, is made so expensive to the caveatee as to be now but rarely acted upon.

In the letters patent which are granted for new inventions, the improvements or inventions are first stated; the prayer of the petitioner to have the exclusive benefit for himself, or his assigns, for fourteen years, is next given, and this prayer is declared to be complied with, according to the statute. After commanding all subjects not to interfere with the patent right, and issuing a mandate to all officers not to molest the patentee in the exercise of it, the letters patent declare the patent void if it appear that the grant is contrary to law, or prejudicial to the subject; or if the thing invented have been in use before the date of the grant, or if the patentee be not the inventor, or if it interfere with prior letters patent, or if the patent be transferred to more than twelve persons (lately increased from five to twelve), or to any who act as a corporate body; or, finally, if the nature of the invention be not described, or the description or specification be not enrolled within *two* calendar months after the date of the letters patent. The letters patent conclude with a declaration, that they shall be construed in the most beneficial sense for the patentee.

It will be observed, that the period allowed for the enrolment of the specification, is but *two* months for an English patent only; but if the patentee declares in his affidavit that it is his intention to solicit patents for Scotland and Ireland also, then he is allowed *six* months to prepare his specification; and if he declares for only one of these countries in addition to England, *four* months are allowed. These periods are, however, sometimes extended upon a special affidavit, and a petition to the Attorney General, setting forth the necessity of the extension. As an instance, we had occasion to solicit a patent for a gentleman, who discovered that the *kernel* of the palm-nuts, previously thrown away as valueless, contained more valuable oleaginous matter than the outer rind, from which the oil was usually extracted; and although the process for obtaining the oil could be specified by the operations that had been made upon a small quantity, still it was of importance that the public should be informed, through the medium of the specification, of the best mode of procedure on the large scale, to determine which, it was necessary to procure a supply from South America; on this plea, we procured *twelve* months to specify. However long a period a patentee may have to specify, he rarely finds it too much; very frequently, indeed, he is unprepared to supply all the details in a satisfactory manner to himself when he is required to complete his specification. For these reasons, we always recommend our clients to express in their affidavits that it is their intention to take out patents for the three kingdoms, if they have the remotest intention of so doing, as they thereby obtain *six* months to specify, which is a

positive advantage. The expression of an intention is not considered as obligatory to do otherwise than just as the interest of the party may afterwards dictate; and when a patentee declines taking advantage of the longer term to specify, he exposes himself to the liability of being robbed of his invention by a rival; thus,—suppose A to have obtained in June a patent for improvements in the steam engine, and to have six months to specify. B invents other improvements in the steam engine, which he patents in July, and has only two months to specify; B's specification is enrolled in September; then A goes to the office and reads it, obtains, if he pleases to pay for it, an office-copy, takes it home with him, and inserts, at his leisure, the whole, or as much of it as he pleases, in his specification that is due in December; now as A has a prior claim by the date of his patent, B is irremediably robbed of his invention and his patent right too.

In obtaining a patent for Scotland, the first proceedings are the same as for England, but the petition is referred to the Lord Advocate, upon whose report the king issues his warrant, and the remaining business is executed in Scotland without requiring the king's signature to the bill. Four months is the time allowed to specify a Scotch patent. The patent is written in the Latin language.

In soliciting an Irish patent, the affidavit and petition is sent with a reference from the king to the Lord Lieutenant at Dublin; but as his lordship knows nothing of such matters except the fees they conduct into his pocket, he refers the never-discussed point of the propriety of granting the patent, to the grave consideration of the Irish Attorney and Solicitor General, both of whom sign their names to a lithographed report, for doing which they pocket an enormous fee. The subsequent proceedings are nearly similar to those of an English patent, excepting that they are much longer in completion.

The time required for completing an English patent under the most favourable circumstances, that is without opposition, is three weeks; but by the payment of additional or "expedition" fees, it may be done in a fortnight by an active agent. A Scotch patent takes also about three weeks; but an Irish patent takes full six weeks. Before the period when Mr. Stanley came into office, as Secretary for Ireland, it was difficult to get an Irish patent completed in six months!

The cost of patents for England, Scotland, and Ireland, are stated in a printed report of the Committee of the House of Commons, to be as follows:—

	£	s.	d.
For England, to one person only . . . . .	106	11	8
"    if to two persons, an additional . . . . .	20	0	0
"    if the Colonies be included . . . . .	5	0	0
For Scotland . . . . .	79	10	5
For Ireland . . . . .	128	5	11

The expenses of the specification are to be added to the foregoing, which depend entirely upon its length, the trouble of preparing it, and the quantity of drawings. It cannot be less than ten pounds; and the average cost may be stated at about twenty pounds each, though there have been instances of the costs exceeding one hundred pounds, when it has been necessary to describe minutely very extensive mechanism, accompanied by numerous elaborate drawings. The expense is frequently much increased by the inventor not having well digested all his plans, and working drawings having to be made out by the head and from verbal descriptions, which generally require much alteration and study before they are complete. A material part of the before-mentioned costs of specifications, consists in the stamps and enrolment fees, amounting, we think, to about half of the whole; the remaining half forming the compensation to the agent employed to write, making out the drawings, &c. of the specification. But if the patentee feels himself competent to execute this task in a proper manner, he may save himself this half of the expense; nevertheless, if he has not previously been a patentee, and thereby become acquainted with all the requirements of the law in this most essential proceeding, it would be imprudent in him not to avail himself of the advice or assistance of one more experienced in matters of the kind. The specification is engrossed upon parchment, the first skin bearing a five pound stamp, and every

succeeding skin, or second 1080 words, stamps of one pound each. Two sets or drawings are required, one on paper, the other on vellum or parchment; the latter are retained in the office, and are stitched to the copy of the patent on the "rolls." After this is done, the specification that was deposited, and the drawing on paper, will be returned to the patentee on application at the office; at which time the balance of the enrolment fees (a sum having been previously deposited) is demanded. The fees of enrolment of a Scotch patent are considerably more than for an English one, and the stamps are the same. The fees chargeable for an Irish patent, as well as the stamps, are less than those for an English one.

Since the foregoing was prepared for the press, an Act of Parliament for the amendment of the patent laws was introduced by Lord Brougham, and passed on the 10th September, 1835, of which the following is an abstract:—

"1. Any person who, as grantee, assignee, or otherwise, hath obtained letters patent for any invention, may enter with the clerk of the patents of England, Scotland, or Ireland, respectively, having first obtained the leave of the Attorney General, or Solicitor General in case of an English patent, of the Lord Advocate or Solicitor General of Scotland in the case of a Scotch patent, or of the Attorney General or Solicitor General for Ireland in the case of an Irish patent, a disclaimer of any part of either the title of the invention, or of the specification, stating the reason for such disclaimer; or may, with such leave as aforesaid, enter a memorandum of any alteration in the said title or specification, *not being such disclaimer or such alteration as shall extend the exclusive right granted by the said letters patent*; and such disclaimer or memorandum of alteration shall be deemed to be part of such letters patent, or such specification, in all courts whatever: Provided that any person may enter a caveat against such disclaimer or alteration; which caveat shall give the party a right to have notice of the application being heard: Provided also that the Attorney General or Solicitor General, or Lord Advocate, may, before granting such fiat, require the party applying to advertise his disclaimer or alteration, and shall, if he require such advertisement, certify in his fiat that the same has been duly made.

"2. If, in any suit, it shall be proved, or specially found by the verdict of a jury, that any person who shall have obtained letters patent for any invention, was not the first inventor thereof, or of some part thereof, by reason of some other person or persons having invented or used the same, or some part thereof, before the date of such letters patent; or if such patentee or his assigns shall discover that some other person had, unknown to such patentee, invented or used the same, or some part thereof, before the date of such letters patent; or if such patentee or his assigns shall discover that some other person had, unknown to such patentee, invented or used the same, or some part thereof, before the date of such letters patent, it may be lawful for such patentee, or his assigns, to petition His Majesty, in council, to confirm the said letters patent, or to grant new letters patent; which petition shall be heard before the judicial committee of the privy council; and such committee, upon being satisfied that such patentee believed himself to be the first and original inventor, and that such invention, or part thereof, had not been publicly and generally used before the date of such first letters patent, may report their opinion that the prayer of such petition ought to be complied with; whereupon His Majesty may, if he think fit, grant such prayer: and the said letters patent shall be available in law and equity to give to such petitioner the sole right of using, making, and vending such invention as against all persons whatsoever, any law, usage, or custom to the contrary thereof notwithstanding.

"3. If any action at law, or any suit in equity for an account, shall be brought in respect of any alleged infringement of letters patent, or any *scire facias* to repeal such letters patent, and if judgment shall pass for the patentee or his assigns upon the merits of the suit, the judge may certify that the validity of the patent came in question before him, which certificate being given in evidence in any other suit or action whatever touching such patent, if judgment shall pass in favour of such patentee or his assigns, he or they shall receive treble costs, to be taxed at three times the taxed costs, unless the judge shall certify that he ought not to have such treble costs.

"4. If any patentee shall advertise in the London Gazette three times, and in three London papers, and three times in some country paper, published in the town where, or near to which, he carried on the manufacture of any thing made, according to his specification; or near to, or in which he resides, in case he carried on no such manufacture; or published in the county where he carries on such manufacture, or where he lives, in case there shall not be any paper published in such town, that he intends to apply for a prolongation of his term of sole using and vending his invention, and shall petition His Majesty in council to that effect; any person may enter a caveat; and if His Majesty shall refer the consideration of such petition to the judicial committee of the privy council, and notice shall first be by him given to any person or persons who shall have entered such caveats, the petitioner shall be heard by his counsel, and witnesses, to prove his case, and the persons entering caveats shall likewise be heard by the counsel and witnesses; whereupon, and upon hearing and inquiring of the whole matter, the judicial committee may report that a further extension of the term in the said letters patent should be granted, not exceeding seven years; and His Majesty is, if he shall think fit, to grant new letters patent for the said invention for a term not exceeding seven years after the expiration of the first term: Provided the application by petition shall be made and prosecuted with effect before the expiration of the term originally granted in such letters patent."

5 and 6 introduce some alterations in the forms of process in actions for infringement.

"7. That if any person shall write, stamp, &c. upon any thing the name, or any imitation of the name of any other person who hath obtained letters patent for such thing, without leave in writing; or if he shall write, stamp, &c. on such thing without leave, as aforesaid, the words 'patent,' 'letters patent,' or 'by the king's patent,' or any words of the like kind, meaning, or import, he shall, for every such offence, be liable to a penalty of 50*l.*"

It is necessary we should not omit to inform the reader that very recently an Act was introduced by the Duke of Richmond, and received the sanction of the legislature, for the abolition of voluntary and extra-judicial oaths and affidavits; by the provisions of which it is now indispensable that an inventor who applies for a patent should first make a "*declaration*" in lieu of the affidavit, of which we have given the form on page 266; and this declaration must be couched in the terms expressed in the Act, which we have not space to insert.

**PAVING, or PAVEMENT.** A layer or covering of stone or brick, carefully laid over roads, paths, halls, passages, &c., and to form stone floors in the interior of buildings. Pavements of flint and flags, in streets, are commonly laid dry, that is, in beds of sand or gravel; those of stables, courts, ground-rooms, &c. are laid in a mortar of lime and sand, or in lime and cement, especially if there be cellars underneath. Sometimes, after a floor of stone or brick has been laid dry, a thin stratum of mortar is spread over it, and worked into the crevices, to fill up all the joints. The several kinds of paving are as various as the materials of which they are composed, the adoption of which depends usually upon local circumstances and the expense: the following are the principal kinds.

1. **Pebble-paving**, frequently laid in ornamental design, is done with kidney-shaped stones, obtained from Guernsey and other places; it is extremely durable when properly performed.

2. **Rag-paving**, formerly much used in London: the stone is obtained from Maidstone, in Kent, whence the name of Kentish rag-stone; there are square stones of this material for coach-tracks and footways.

3. **Purbeck pitchens**; stones from six to ten inches square, and five inches deep, brought from the island of Purbeck, and frequently used in court-yards.

4. **Square-paving**, by some called Scotch-paving: by this was recently understood cubical stones, of blue whynn; they are, however, now nearly disused in London, owing to their inferiority of the next-mentioned.

5. **Scotch granite**; a hard material, usually of a bluish or reddish colour, with which the London road-pavements are formed.

6. **Guernsey and Herm blue-granite**; extensive quarries being now opened at the latter island, chiefly for the supply of the London pavements, for which purpose it is found to answer as well, if not better, than the Scotch. The stones

are prepared of a prismatic figure, by means of iron hammers, and are usually laid with their end downwards, bedded in gravel.

7. Purbeck-paving, of the blue sort, in large surfaces, and about 2½ inches thick, make excellent flag pavements.

8. Yorkshire-paving, of large dimensions, is equally good with the former, is impervious to water, and unaffected by frost.

9. Ryegate, or firestone-paving, is used for hearths, stoves, ovens, and such places as are liable to great heat, which does not affect the stone, if kept dry.

10. Newcastle flags are about two feet square, and two inches thick: answer well for out-offices.

11. Portland-paving, from Portland, sometimes interspersed with black dots.

12. Swedland-paving is a black slate, dug in Leicestershire; much used in paving halls, especially in party-coloured paving.

13. Marble-paving, frequently variegated with different coloured marbles, and sometimes inlaid in mosaic.

14. Flat-brick paving, done with brick laid in sand and mortar, or groute, as when liquid lime is poured into the joints.

15. Brick-on-edge paving, done with brick, laid edgeways, in the same manner.

16. Bricks laid flat or edgeways, arranged in herring-bone fashion.

17. Bricks set endways in mortar, sand, or groute.

18. Paving-bricks, made especially for the purpose.

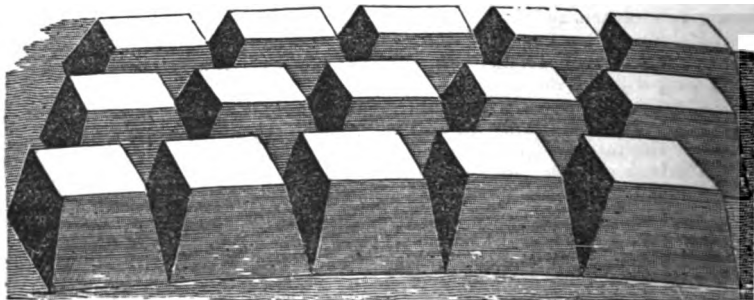
19. Paving with ten-inch tiles.

20. Paving with foot tiles.

21. Paving with clinkers, for stables, &c.

There are many other kinds of paving, equally worthy of notice with the foregoing, but it would be needless to extend the description. We must not, however, omit to mention a beautiful imitation of mosaic, in various colours and designs, now manufactured of pottery-ware, some specimens of which we have seen at the Museum of National Manufactures and the Arts, in Leicester-square. Pavements of churches and other handsome buildings frequently consist of stones of various colours, but chiefly black and white, in squares or lozenges, artfully disposed. There needs no great variety of colours to make a surprising diversity of effect. It has been shown, that two square stones, divided diagonally into two colours, may be joined together, in checkers, sixty-four different ways, as each admits of four different situations, in each of which the other square may be changed sixteen times, which gives sixty-four combinations. A very beautiful example of a tessellated pavement, in black and white, is afforded in the extended floor of St. Paul's Cathedral, which is well worthy of examination by those who have occasion for works of that nature.

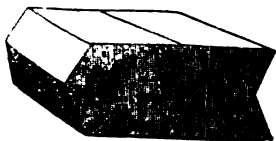
Having stated the various kinds of pavement as commonly practised by masons, we proceed to notice several deviations from that practice, which have been much talked of, and partially brought into use. The first we shall describe is the patented improvement of Mr. Abraham H. Chambers, of New Bond-



street, London; the object is for paving the horse and carriage-ways of our public streets. Mr. Chambers forms the bed of earth or gravel of the usual figure, which is a slightly elevated arch; this foundation is to be rendered as

firm and solid as possible, by ramming, previous to laying down the stones, which are in form like the lower portion of a regular quadrangular pyramid, and are arranged so that the sides of each stone shall overlap those in the next row, as exhibited in perspective in the preceding cut. When they are thus laid uniformly and evenly, with their broadest surfaces or bases downward, a quantity of some of those stone-like cements, of which lime is the basis, or the British puzzolana, is to be poured between the joints, filling them to about one-third of their depth: when this has become hard, so as to cement the whole into one solid body, the remaining two-thirds of the interstices are to be filled with broken flints, granite, or other hard materials. On each side of this roadway are to be constructed deep brick gutters, for the reception of the water, and the small portion of mud that may be formed; and midway, between each side and the centre of the road, lateral trenches are to be dug, to lead, by an oblique descent, into the brick gutters: these trenches are to be filled with broken bricks and stones, and serve as a filter, to convey nothing but the water from the middle of the road into the gutters. The patentee considers that a paved carriage-way, constructed upon this plan, will be extremely durable, and will be kept free from mud and sludge.

The patent *triangular pavement* is founded (as the inventor states), upon the reciprocal bearing and support of the stones. The pavement is formed of granite, or other hard paving stones, of the ordinary size, and each stone is laid or ranged in such a manner, with reference to the several contiguous stones, as that neither can be displaced the eighth of an inch, by any pressure or percussion, however great, in the ordinary use of the streets. The stones are not wedges or cubes, but formed as represented in the subjoined diagram, each containing a protruding or salient angle on the one side, and an indented or receding angle on the opposite side; the receding angle being formed to receive the salient one. Although the first cost of a pavement of this kind may be greater than ordinary, its probable greater dura-



bility will, most likely, more than compensate; besides, its level symmetry, cleanliness, and solidity of construction, derived by each part from the whole superficies, seem to be advantages attached to this species of pavement.

In Macknamara's patent pavement, the stones are comparatively thin, flat squares; their upper faces have two of the opposite sides of the quadrangle beveled off to an angle of about forty-five degrees; and underneath each stone the reverse sides of the quadrangle are beveled off in like manner, so that when laid together in the manner exhibited in the engraving on the next page, they may reciprocally support each other. *Fig. 1* represents a plan of a street paved on this system; *Fig. 2* exhibits a vertical section of the same, the roadway stones being numbered 1, 2, 3, 4, 5, (as shown on the plan); 6 6 are the gutter-stones; 7 7, those which abut against the curb. *Fig. 3* gives a side view of three entire stones, exhibiting the reverse position of the beveled edges, by which the stones are mutually supported. *Fig. 4* represents the opposite sides & edges of the same stones.

"By a careful attention to the figures, it will be seen," says the patentee, "that each and every individual block or stone mutually and reciprocally support, and are supported by, each other. This principle will be found to apply throughout, each block or stone being upheld by two adjoining ones, and, in return, mutually supporting others that are made to rest upon it. These blocks may be made of any convenient size; the principal object to be attended to is to make the bounding lines on the upper surface as perfect as the nature of the stones will admit. I shall here observe, that when blocks are used of large dimensions, it will be proper to groove their surfaces to form a better foot-hold for horses; and in order to identify my invention, and thereby endeavour to prevent any infringement on this patent, that it consists solely in working, cutting, or forming the sides of my blocks or stones, so that they shall make



alternately obtuse and acute angles, with the upper surface of the block or stone which, being done, they may be so arranged or combined, that they will

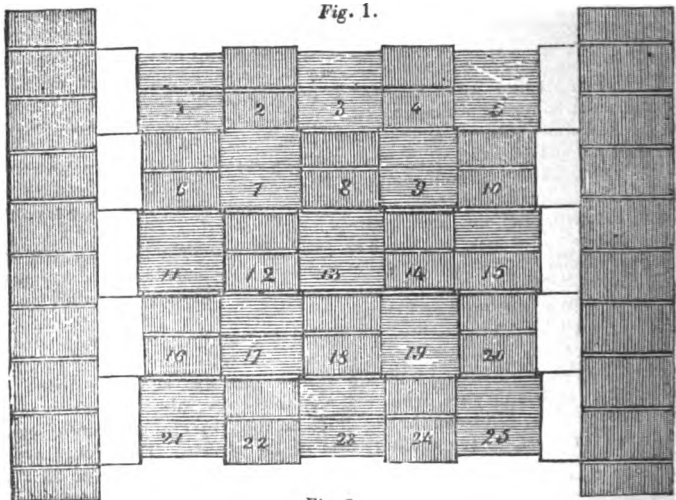


Fig. 2.



Fig. 3.



Fig. 4.



mutually and reciprocally support and preserve each other from the imperfection so generally found in the usual practice of paving."

**PEARLS.** A calculus or morbid concretion, formed in consequence of some external injury which the muscle or shell-fish receives that produces it, particularly from the operations of certain minute worms, which occasionally bore even quite through to the animal. The pearls are formed in the inside, on these places: hence it is easy to ascertain, by the inspection of the outside only, whether a shell is likely to contain pearls. If it be quite smooth, without cavity, perforation, or callosity, it may with certainty be pronounced to contain none; if, on the contrary, the shell be pierced or indented by worms, there will always be found either pearls, or the embryos of pearls. It is possible, by artificial perforation of the shells, to cause the formation of these substances. The process which has been chiefly recommended is to drill a small hole through the shell, and to fill it up with a piece of brass wire, rivetting this on the outside, like the head of a nail; and the part of the wire which pierces the interior shining coat of the shell will, it is said, become covered with a pearl. As to the value of British pearls, some have been found of a size so large as to be sold for 20*l.* each, and upwards; and 80*l.* was once offered and refused for one of them.

*The oriental pearl muscle*, to which we are indebted for nearly all the pearls of commerce, has a flattened and somewhat circular shell, about eight inches in diameter, the part near the hinge bent or transverse, and imbricated, or covered like slates on a house, with several coats, which are toothed on the edges. Some of the shells are, externally, of a sea-green colour, others are chestnut or reddish, with white stripes or marks, and others whitish, with green marks. These shells are found both in the American and Indian seas. The principal

pearl fisheries are off the coasts of Hindoostan and Ceylon; they usually commence about the month of March, and occupy many boats, and a great number of hands: each boat has generally twenty-one men, of whom one is the captain, who acts as pilot; ten row and assist the divers; and the remainder are divers, who go down into the sea alternately, by five at a time. The largest round pearl that has been known belongs to the Great Mogul, and is about two-thirds of an inch in diameter. Pearls from the fishery of Ceylon are considered more valuable in England than those from any other part of the world. The smaller kinds are called seed or dust pearls, and are of comparatively small value, being sold by the ounce, to be converted into powder. To make the artificial, take the blay or bleak fish, common in the Thames; scrape off the silvery scales from the belly; wash and rub these in water; then suffer this water to settle, and a sediment will be found, of an oily consistence. A little of this is to be dropped into a hollow glass bead, of a bluish tint, and shaken about so as to cover all the internal surface: after this the bead is filled up with melted white wax, to give it solidity and weight.

The Roman pearls are formed of a very pure alabaster, considerable quarries of which exist near Pisa, in Tuscany. The process is as follows:—the alabaster is first sawn into alices, the thickness of the pearls required; the pearls are then formed with an instrument which bores a small hole in the centre, at the same time that the required shape is obtained. The next thing in the process is their immersion in boiling wax, to give them a rich yellow hue, and afterwards to cover them several times with the silvery substance obtained from the scales of the bleak. The singular beauty of this ornament, which perfectly resembles the real pearl, the varied patterns in which they are arranged, and their extreme cheapness, render them an object much sought after; while their solidity is such, that they may be dashed to the ground with violence without receiving the slightest injury; being thus rendered far superior to those of French manufacture, which are at once more fragile, and considerably less imitative.

The Chinese in a manner force the production of real pearl, in the animal itself. They collect the *myca margarite fera*, or European pearl muscle, and pierce the outsides of the shells in several parts, without completing the perforation throughout. The animal, becoming conscious of the weakness or deficiency of the shell in those particular spots, deposits over them a great quantity of its pearly calcareous matter, and thus forms so many pearly tubercles over them. The pearls thus obtained are, however, said to be generally inferior to those naturally produced. Pearls that are discoloured may be thus whitened: "Soak them first in hot water, in which some bran with a little tartar and alum have been boiled; rub them gently between the hands, which may be continued until the water grows cold, or until the object is effected, when they may be rinsed in lukewarm water, and laid on writing-paper, in a dark place, to cool." The foregoing is extracted from the scientific journals; but we have always understood that real pearls, so discoloured, are scaled by the lapidaries, that is, they take off the upper coat or lamina, which leaves them slightly diminished in size, but equally beautiful to their primitive state.

**PEARL, MOTHER OF.** The shell, not of the pearl oyster, but of another kind of oyster, the inside of the shell of which is very smooth and polished, and of the whiteness and water of pearl itself. The shell has the same lustre on the outside, after the outer coat, or lamina, has been removed by aqua-fortis and the lapidary's mill. It is used for the handles of knives, inlaid work, &c.

**PEARLASH.** An impure potash, obtained by lixiviation of the ashes of plants. See **POTASH**.

**PEARL-SHELL.** A new process of working pearl-shell into a variety of devices, for the purpose of applying it to ornamental uses in the manufacture of japan ware and other articles, has lately been invented by Messrs. Aaron Jennings, and John Betteridge, of Birmingham. The process is similar to that of engraving on metals in relief, by the aid of corrosive acids and the etching-point. The pearl-shell is first divided into very thin plates or leaves, such as from the 40th to the 100th part of an inch, and the devices or patterns are drawn

upon them in an opaque turpentine varnish; strong nitrous acid is then brushed over the plates repeatedly, until those parts left bare, or undefended by the varnish, are sufficiently corroded, or "eaten away" by the acid. The varnish being now washed off by a little oil of turpentine, the device, which the acid has not touched, is found to be perfectly executed. If the design is to be after the manner of common etching on copper, then the process upon the shell is precisely similar to that already explained under the article *ENGRAVING*. When a considerable number of ornaments are required of the same size and pattern, a sufficient number of the plates are cemented together by glue, with only one plate, having the device etched upon it, placed on the outside; these are then made fast in a pair of clams, or screwed between the jaws of a vice, and carefully sawn out altogether by a very fine frame-saw: the cemented shells are then thrown into warm water, which softens the glue, and quickly separates the pieces. When several devices upon a plate have been bit in, they may be laid upon a flat surface, and cut through with a knife-edged tool; for thick pieces the saw is put in requisition, and the finishing executed by a variety of sharp gravers and instruments.

**PEARL-WHITE.** An oxide of bismuth. It is employed as a cosmetic, to whiten the skin; but its tendency to become black, by exposure to the action of sulphuretted hydrogen mixed with the atmosphere, renders it a very dangerous expedient to heighten female charms.

**PEAT.** A spongy black earth, combined with decayed vegetable matter: when dried, it forms a valuable fuel.

**PECK.** An English measure; the fourth part of a bushel.

**PEDOMETER**, *foot-measure*, or *way-wiser*, is a machine in the form of a small time-piece, containing a train of toothed wheels, which, by means of a chain or string, fastened to a man's foot, or to the wheel of a carriage, are made to move one notch or tooth at each step, or each revolution of the wheel; and the train thus uniformly moved being connected to an index, points out the distance travelled, on a graduated dial-plate.

A patent for "an improved pedometer for the waistcoat pocket, upon a new and very simple construction," was taken out by Mr. William Payne, of New Bond-street, in 1831. It is of the form, and of the usual size, of a common watch, and consists of a lever or pendulum, one end of which is weighted or inlaid, and the other supported by a delicate spring; by which arrangement, each step of the wearer produces a vibration, and moves a ratchet wheel one tooth, and the latter being geared into a train of wheels (similar to those of a common counting machine) moves indexes or hands over the face of a dial-plate, on which the number of vibrations or steps are indicated. The patentee also attaches his pedometers to an ordinary watch, in which case, the train of wheels and other parts are placed under the dial-plate or face of the watch.

**PEN.** A well-known instrument for writing. In the earliest ages, writing was executed with styles of metal or other hard substance, which, after a time, were superseded by pens and coloured inks. The first pens were made of reeds, or small hard canes, about the size of the largest swan quills, cut and split in the same manner as the pens in present use. According to Isidore, and some other writers, *quill-pens* were first introduced about the year 636; they did not come into general use, however, till the middle of the seventh, and were not common till towards the close of the eighth century. Reed-pens continue to be employed up to the present time, for writing some of the oriental languages, and by artists, for sketching outlines. The greater number of pens now in use are made from the quills of the goose—those of the swan, turkey, duck, and crow, being occasionally employed—the two latter exclusively for very fine writing or drawing. As the making or mending of quill-pens is to many persons difficult of attainment, and to all, at times, inconvenient, various attempts have been made to render the process less frequently required. One of these methods consisted in arming pens made of turkey-quills with metallic points or nibs, by which their durability was somewhat increased, although at the expense of the natural elasticity of the quill; nor was the durability sufficiently extended to be commensurate with the additional cost. To do away with the

necessity of frequent pen-mending, Mr. Bramah took out a patent for an improvement in pens, which consisted in dividing a quill longitudinally, and cutting it into four or six lengths, according to the size of the barrel. Each of these pieces formed a pen—some two, by being cut at each end. The pens thus formed were held in a jointed silver holder, which imparted great firmness to the quill, while it permitted the free action of the nibs. Pens have been made from horn, also from tortoise and other shells; but no useful application has hitherto been made of such pens, as they are more expensive and even less durable than those made from quills. Some successful attempts have been made to form the nibs of pens of precious stones, in order that they may be used a long time without wear or corrosion. The first that we recollect were introduced by Messrs. Hawkins and Mordan, whose specification of 1823 states, that they make use of tortoise-shell or horn, instead of quills; and when the material is cut into nibs, these parts are softened in boiling water, and then small pieces of diamond, ruby, or other precious stones, are imbedded into them by pressure; by this means, it is said pens of great durability as well as elasticity are made. To give stability to the nibs, the patentees proposed to affix to the tortoise-shell, or horn, thin pieces of gold or other metal, and attaching the same by the before-mentioned or any other convenient means, as cement or varnish. It is likewise suggested that springs may be placed on the back of the pen, as shown in the annexed figure, which may be slid backward or forward, to vary the elasticity according to the different hands that may be required in writing. We are informed by a gentleman who had one of these pens many months in constant use, that it had exhibited no signs of deterioration or wear. Mr. Doughty, of Great Ormond-street, has likewise devoted much attention to the construction of pens, the nibs of which are rubies set in fine gold. They are said to write as fine as a crow-quill, and as firm as a swan-quill—to possess considerable elasticity, and produce an uniform manuscript, unattainable by ordinary pens. Mr. Doughty states, that “some of his ruby pens have been in constant use upwards of six years, and continue still perfect; and that if a little care be taken of the nibs, by preventing their being struck against hard substances, and occasionally washing them with soap and water, with a little brushing, they will be found, notwithstanding their first cost, *economic pens*.” The rhodium pens, consisting of two flat strips of gold placed angularly side by side, and tipped with a hard metallic alloy, are very durable, though not equal to the ruby nibbed. Under the head *INKSTAND*, we have given Mr. Doughty's contrivance to prevent injury to his pen-nibs in dipping for ink.



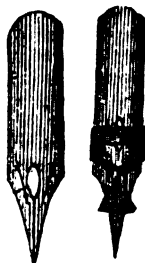
The first decided attempt to introduce *metallic pens* to general use, was made by Mr. Wise, whose “perpetual pens” will doubtless be remembered by many of our readers. The name of Wise was rendered conspicuous in most of our stationers' shops, some twenty-five or thirty years since, as the original inventor and genuine manufacturer of the steel pens; they consisted of a barrel-pen of steel, mounted in a bone case, for convenience for carrying in the pocket. Notwithstanding his productions possessed but in a very remote degree the requisite properties of a writing instrument, and were extremely dear, he managed to make a scanty livelihood out of the business, by dint of unwearied exertions in promoting their sale. Mr. Donkin subsequently made some excellent steel pens, but the price was high, and the demand inconsiderable. This description of pen has recently been very much improved, especially by Mr. Joseph Gillott, of Birmingham, who is the largest manufacturer of steel pens in the world, converting annually upwards of forty tons of fine steel into writing pens. The improvement has been accomplished by employing metal of a better quality in a thinner and more elastic state—by making the slit shorter, and by more carefully attending to the finish and temper of the pens. These improvements in quality have also been attended with so great a reduction in price, that a *gross* of the improved steel nibs may now be purchased for very little more than was formerly charged for *one* of Wise's pens. The common three-slit pen, that is, the pen with a slit on each side of the central slit, is with many persons still a favourite, and some of these pens

seem to embody most of the advantages of which metallic pens are susceptible. Their present excellence and extreme cheapness seems to promise the almost entire disuse of quills, although, up to the present time, there has been no falling off in the demand for this article.

Mr. James Perry, of London, has contributed, we believe, more than any other individual to the introduction of the modern improved steel pens; he has brought out several steel pens of a very ingenious and original description, and devoted more than ordinary attention to the forming them to suit a variety of hands and tastes, which he regularly classed, advertised, and humorously puffed in rhyme, by which means he acquired a celebrity to which no previous pen-maker had attained. Mr. Perry first overcame the extreme rigidity of the ordinary steel-pen, by the introduction of apertures *between the shoulders and the point*, thereby making them elastic below instead of above the shoulder: this was the subject of his patent of 1830. "The double patent Perryian pen," the merits of which have been so much placarded throughout the kingdom, received its odd cognomen from the circumstance of a second patent taken out by Mr. Perry, in 1832; the pens described in the specification of which are represented as combining the superlative qualities of both inventions. Fig. 1 is a sketch of Mr. Perry's "double patent pen," which distinctly shows the position of the aperture and the lateral slits, by which a great degree of elasticity is obtained. Fig. 2 is Mr. Perry's ingenious "regulating-spring pen," consisting of one of his patent pens, with the addition of a sliding spring, which increases or diminishes the flexibility of the pen, according as it is placed further from, or nearer to the point. In another instance Mr. Perry employs the elasticity of Indian-rubber, by twisting a thread of this material round the nibs of the pen, the yielding of which permits the opening of the points, in proportion to the pressure applied. The care which Mr. Perry takes in the correct manufacture of his pens, has mainly contributed to the general preference given to them; for, however excellent may be the principle of the structure, if the workmanship of the nibs be not nicely performed, the pens will not write well. It is from defects of this kind, we believe, that many apparently excellent metallic pens, that have been successively brought out, have met with a comparatively small sale.

As the extremities of the nibs of metallic pens of the ordinary form become worn, they progressively increase in breadth, until they become useless, unless their original form should be restored by skilful filing, or grinding, upon an oil-stone: these being operations which no economist of time will perform, at the present low prices of the article, Mr. Gillott, of Birmingham, took out a patent in 1831 for an improvement in metal pens, designed to remedy the defect mentioned. This he proposed to effect by making the nibs of his pens parallel sided, that is, an equal breadth to the points for about an eighth of an inch long, the remaining portion or upper part of the nibs being cut either inclined in the usual manner, or terminating with a shoulder next to the parallel nibs. "The whole length of such nibs," says Mr. Gillott, "may of course be worn away, without increasing the breadth of the strokes in writing." This construction, it however appears to us, will not only fail in obtaining the advantages sought, but will entail disadvantages to which the tapered form is comparatively free; namely, a greater tendency to take a set in opening during the downward strokes of the pen, and a deficiency of reacting force in the up-strokes to bring the nibs together; the narrowness of the points also prevents the ink from flowing down in sufficient quantity to give a constant and unfailing supply. Mr. Gillott, although a pen manufacturer, is evidently no great pen-user, for all persons who are in the habit of using steel pens know that in a short time the abrading action of the paper, produces a basil edge on the under side of the nib, converting it into a very efficient chisel, which, catching the paper in the up strokes, renders the pen unfit for further use. With respect to their

Fig. 1. Fig. 2.



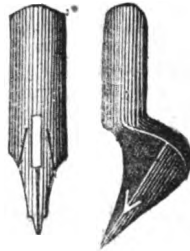
wearing away uniformly, this can never be the case, unless the pen be held vertically, that is at right angles to the plane of the paper, in which manner ordinary writing cannot be executed. This will at once show the fallacy of Mr. Gillott's proposition; and it would appear as if Mr. Gillott was himself conscious of the error; for we have never met with any of his pens made in accordance with his patent, that is, with *parallel* points, but as *Fig. 3*, which is one of Mr. Gillott's pens, as now manufactured; otherwise this is a pretty good pen, and ranks with the best of the *three-slit* class.

The position in which a pen is usually held causes the wear to take place in an inclined direction, slightly rounded at the edges, and the right hand nib to be more worn than the left. When one nib becomes shorter than the other, the longer nib bears harder than the shorter upon the paper in the up-strokes, and produces thick and blotted writing. It was probably with a view of obviating these effects that the scribes of olden time wrote their letters either upright, or inclining to the left hand, both of which modes are retained by the lawyers. Making due allowance for the *obsolescence* of many of the characters, we think it must be admitted that such writings possess more clearness and intelligibility of form than our modernized writing.

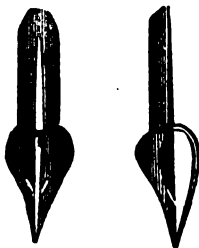
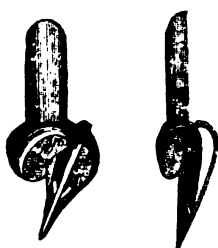
In order, however, that we may be able to incline our letters in the *right* direction, and yet save our pens from rapid destruction, Messrs. Mordan and Broekeden introduced, and patented in 1831, pens with inclined slits, which they very appropriately designated the "oblique pen." It has been stated, as a well-authenticated fact, that ninety-nine persons in every hundred fail to attain, permanently, the art of writing with a pen in the true position; that is, with the hand removed a little to the right, and the tip of the pen pointing to the right shoulder, when the slit of the pen will be in the direction of the writing, and both of the nibs addressed fairly to the paper. *Fig. 4* is a representation of Messrs. Mordan & Co.'s oblique pen. The direction of the slit in this pen being that in which the writing usually slopes at an angle of about thirty-five degrees, both nibs are brought equally down upon the paper—the writer is not confined to any particular position, but at liberty to use the pen freely, without the restraint of attitude, so strongly insisted upon by teachers of writing. The action of the oblique steel pen is altogether remarkably good, and, from the shape of the nibs immediately below the shoulder, it has a most excellent spring, producing a pleasing effect both in the up and down strokes of the writing; it glides smoothly over the paper, and is altogether free from the harshness so much complained of in steel pens. These oblique pens are made of the best steel, in a very thin and highly elastic state; the arched form gives the requisite strength, where it is necessary they should be firm and unyielding, and also enables them to carry more ink than any previous pens. The advantageous property of this particular form, for holding a large quantity of ink, was at once perceived by other manufacturers, and led to the construction of the Lunar, Gonidon, and some other similar pens. Messrs. Mordan & Co.'s specification describes a variety of modifications of pens and pen-holders, illustrated by numerous figures. In the first place are shown quill-pens and portable pens, (the latter implying short pieces,) having inclined slides, and metal pens similarly formed. To apply the principle to pens cut in the usual manner, with straight or longitudinal slits, handles are provided, which have at their lower ends curved metal arms, with clips or holders, which fix the pens at an angle, diverging from thirty to forty degrees out of the line formed by the handles. Some of these pen-holders are furnished with joints and set-screws, to enable the writer to place the pens at such an inclination, with respect to the handle, as will accord with the inclined position of the letters he is making. The latest improvement in steel pens is one by Mr. Gowland, consisting in the introduction of an additional nib. The following engravings represent three pens of this

Fig. 3.

Fig. 4.



description, as manufactured by Messrs. Mordan & Co., under a recent patent *Fig. 5* are back and side views of Messrs. Mordan and Co.'s patent three-nibbed

*Fig. 5.**Fig. 6.**Fig. 7.*

*slip-pen.* *Fig. 6* are similar views of their patent three-nibbed *flat-spade*, or, as the Birmingham manufacturers call it, the *lunar pen*. In each of these pens, the additional nib is formed by cutting it out of the stem or shank of the pen, where there is always a superfluity of metal, and turning it back over the other nibs. *Fig. 7* are back and side views of Mordan & Co.'s patent three-nibbed *counter-oblique pen*. Many persons having been strongly prejudiced against the one-sided appearance of the original oblique pen, Messrs. Mordan & Co. were induced to attempt an improvement in this respect, and they have fully succeeded. The improvement has been accomplished by the introduction of an additional shoulder, opposed to the former. This novel and curious pen has been very much admired, and it is as useful as curious; it has the advantage of holding a very considerable quantity of ink, and of retaining, from its obliquity, a position adapted to the slope of the writing, while to the eye a perfect equilibrium is preserved. The effect of the third nib in metallic pens, is to enable the pen to carry a larger quantity of ink, and to force it down in uniform and never-failing succession to the paper. Every time such pens are pressed on the down-strokes of the writing, the ink flows in a body towards the point from the effect of capillary attraction, at the precise time when it is most wanted. This result is produced by the third nib forming a conical tube with the other nibs of the pen, with its smallest end downward, and always causes the ink to flow equally, as much on the centre of the down-strokes as the two points of the pen itself. The capillary attraction, which is brought into operation in this ingenious contrivance, completely counteracts the defects existing in other pens, arising from the opening in the slit tapering in the opposite direction to that which is requisite, for the purpose of fairly conveying the ink to the paper; of this any one may convince himself by pressing the points of any ordinary pen on the thumb-nail, until the slit opens wide enough for large-text writing, when the ink will instantly recede from the points towards the upper extremity or angle of the slit. Capillary attraction always causes fluids to flow towards the narrowest part or opening of every conical tube; and, therefore, in three-nibbed pens, the ink is forced down upon the paper, and the thickest ink would be propelled downwards most effectually by the action of the three nibs. Another advantage of the third nib is, that it clears the slit of the pen, removing the fibres as they are gathered from the paper, thereby removing the greatest objection that has hitherto existed to the use of metallic pens.

The following is the process of making steel pens, as witnessed at the extensive and well-conducted manufactory of Messrs. Mordan & Co., Castle-street, Finsbury, whose liberality, condescension, and urbanity to visitors on all occasions, is gratefully acknowledged by many individuals who have in vain endeavoured to obtain a sight of this interesting process elsewhere. A hardened steel punch and matrix, of the exact size and shape of the pen to be made, having been attached to a powerful fly-press, sheet steel of the finest quality, reduced to about  $\frac{1}{160}$  of an inch in thickness, and in strips of two inches and a half wide,

is taken, and every pen is struck out singly, till the metal is exhausted. In this state the pens are called *blanks* or *flats*. After cutting out, the next operation is softening or annealing; this is performed by putting a great number of the *flats* into an iron box, with a small quantity of tallow on the top of them; the box being shut up close, is placed in a furnace, and there kept until the box appears to be equally heated all over. The box is then withdrawn, and the pens emptied out upon some hot ashes, covered with the same, and left to cool gradually. By this means the pens are sufficiently softened for the subsequent process; but as the flats are very rough and scaly from the effects of the fire, they are first cleaned by being placed in a mechanical agitator with sand, ashes, &c., and well shaken for an hour or two, which renders them remarkably clean and smooth. The makers' name having been stamped on the shank of each pen, and the apertures, if any, cut out, they are marked for the slits. This is done with a very sharp chisel, worked by a fly-press, and so exquisitely adjusted as only to cut through two-thirds of the thickness of the metal. This done, the next operation is the dishing. A hardened steel punch, of the precise form to be given to the pen, being attached to a fly-press, a die is placed beneath to receive it; the die being concave, and the punch convex, and both being made so as to fit each other with the greatest accuracy, the *flat* is forced into the cavity of the die, and retains permanently the form thus given to it. The pens being dished are next hardened, by being placed in the iron box, and heated as in the softening process, except that they are now cooled suddenly, by being thrown into a vessel of cold water or oil. When the pens are quite cold, they are taken out of the water, and placed in a cullender to drain. When dry, they are put into the agitator with a quantity of sawdust, and shaken for a considerable time, which cleans and polishes them, giving a degree of smoothness and finish to the nibs unattainable by any other method equally economical. The agitator is an ingenious piece of mechanism, invented by Mr. Mordan; it consists of a large tin cylinder, supported horizontally by two cranked axles—one at either end,—upon a strong iron frame; another axle, mounted upon anti-friction wheels, at the end of the machine, carries a winch handle and a heavy fly-wheel; upon this axle is also placed a driving wheel, a rigger-band from which puts the crank in motion, and communicates a very rapid elliptical movement to the cylinder and its contents. By this contrivance the pens are very effectually polished, and made ready for the next process—tempering. This is done by placing the pens, a few at a time, on a stove, heated to the proper temperature; so soon as a bright blue colour is obtained they are removed, this colour denoting the temper best suited to steel pens. The last operation is that of opening the slits, or, as some call it, *cracking* the slits; this singular process is effected by placing about a quarter of an inch of the pen's point between a pair of small nippers, and pinching them suddenly, when the slit, which was only cut two-thirds of the way through, is completed by the giving way of the remainder of the metal. This unique process fits the pen for immediate use; some manufacturers add a coat of lacker, but this is not of much real utility.

It has often been supposed that other materials would be equally, if not more, suitable than steel, for the manufacturing of pens; those persons who have paid most attention to the subject, however, are decidedly of opinion that no kind of metal, however fine its texture may be, or whatever properties it may possess, will ever be able to compete with fine well-tempered steel.

Many of the steel pens, as now manufactured, we find of excellent quality; many hundred pages of this work have been written with one pen, in a uniform clear hand. After writing with it about forty pages, we usually renew, and even much improve the nibs of a new pen by a few touches of a dry Turkey stone, aiding the sight with a pair of magnifying spectacles, in order that the form of the extreme end may be duly perfected; this process will, however, be found difficult of accomplishment, at first, by persons unaccustomed to the pointing of delicate instruments, and, at the present low prices of the article, scarcely worth the trouble; but the ability to perform this operation at pleasure upon steel pens, renders a person very independent of the stationer's shop.



In our brief account of this novel and admirable manufacture, we are sensible of having omitted to notice a variety of excellent steel pens, but our allotted space compels us to proceed to the description of a different class.

*Fountain Pens.* A great number of ingenious attempts have been made to construct pens containing a reservoir of ink, which, by a slight pressure on the handle, or other part, might cause a fresh supply of the fluid to flow to the nibs, and thus supersede the necessity of an ink-stand. Of this kind is the *penograph* of Mr. Scheffer, manufactured by Messrs. Mordan & Co., in which the pressure of the thumb on a projecting stud in the holder causes a continuous supply of ink from the reservoir to flow into the pen.

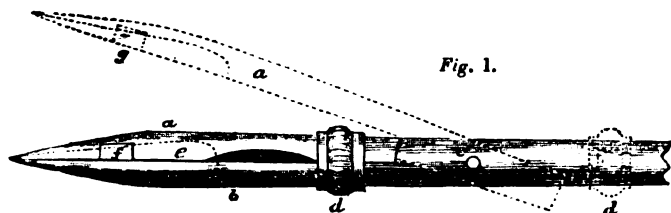
Mr. Parker's *Hydraulic Pen* is a more recent contrivance for the same purpose. In this machine a piston is made to work up and down in a cylindrical tube by means of a revolving nut acting upon the piston rod, which is tapped with a corresponding screw. The small orifice at the bottom of the holder being immersed in ink, the turning of the upper portion of the holder causes the piston to ascend, and the tube becomes filled with ink; on gradually turning the nut in the opposite direction, the piston descends and forces the ink down into the pen. Mr. Parker has taken out a patent for his invention; but, if we mistake not, Mr. W. Baddeley proposed an apparatus, precisely similar, a long time since; for which see the *Mechanics' Magazine*.

As a description of all the contrivances of this kind, however, would occupy many pages, we shall limit our account to one of a very simple and unexpensive kind, the invention of a correspondent of the *Register of Arts*. "The pen is made of two quills; the top one, which I shall call No. 1, and the other, No. 2. Let the end of No. 1 be made air-tight, by dropping inside, to the bottom, a small piece of cobbler's wax, and then warming it a little: fill this nearly with ink,—say about a quarter of an inch from the brim,—then take a small piece of cambric and cover the top of it, so that the ink may not drop out; join both quills together, by putting No. 1 into No. 2, and the pen is ready for use. When you want to write, take the pen in your right hand, give a gentle shock on your left hand, or on a table, and the ink will run down into the pen immediately; this must be repeated every time ink is wanted. A pen of this kind will be found very useful to reporters and to persons travelling. The pen should be put into a little case to carry it about."

*Pens (drawing).*—By this term is commonly understood the mechanical drawing-pens, consisting of a pair of delicately-formed steel blades, the ends of which are drawn together and adjusted by means of a fine set-screw; these pens are mounted with handles of various materials, but those of ivory or ebony are deservedly preferred. These instruments are manufactured by Mr. Elliott, of High Holborn, in the highest perfection. The extremities of the steel blades which form the pen should be very narrow ellipses, and should perfectly meet, without the minutest projection of one piece over the other. The outside of the elliptical end should be rubbed on a hone until it is as thin as the edge of a knife: in this state the points would cut the paper; but the sharpness must be taken off by gently drawing them over the stone upon their edges, and finishing them upon a soft polishing-stone. A smoothness is thus given to their edges, which makes them glide over the paper, although they will still be left so thin that their edges can scarcely be discerned. By this management, lines may be drawn while the points of the pen are at a distance from each other, not perceptibly exceeding the breadth of the lines produced, which is of consequence, not only to the equable flow of so viscid a fluid as Indian ink, but to obtaining a well-defined stroke.

A drawing-pen was lately presented to the Society of Arts, by Mr. Bryan Donkin, which he had brought from France. It is calculated to make lines of only one uniform thickness: the cavity which contains the ink being enclosed all round, keeps it free from dust, and prevents it from drying, and clogging the drawing-point so quickly as those of the ordinary construction. *Fig. 1* (in the following page) shows the pen, with the handle broken off; *a* and *b* are the two limbs, jointed at *c*, and held close by the sliding ring *d*; the dotted lines represent the upper portion *a* as opened, to receive the ink, with the ring *d*

slidden back beyond the joint. *Fig. 2* shows the underside of the limb *a*, in a separate state; at *c* is the hole to receive the centre-pin; *e* is the cavity for



*Fig. 2*

the ink; *g g*, notches for receiving two projecting pieces, as shown at *f* in *Fig. 1*.

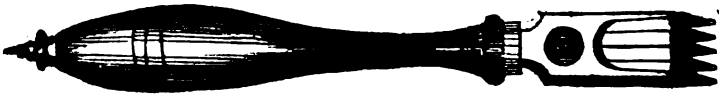
An extremely simple and ingenious mode of making a drawing-pen of the last-mentioned kind (that is, to make a line of only one thickness,) was invented by Mr. Robert Christie; and having made several according to his instructions, which answer very well for tracing, as it moves with equal facility in any direction, we insert a notice of it in this place. The annexed cut represents one of these pens, in a neatly-turned handle; but we made them at the solid end of black-lead pencils, for the convenience of readily using either lead or ink. The process, as directed by Mr. Christie, is as follows:—A piece of sealing-wax, about the size of a marrowfat pea, is to be stuck upon the end of the pencil, by melting it, forming thereby a bulb, into which are to be inserted three darning-needles, by warming their eyes in the flame of a candle, and then burying them in the wax, at equal distances apart, around the circumference of the pencil, with their points extending about three-quarters of an inch beyond the end of it; but brought together so as to meet as accurately as possible at a common focus, forming the outline of a triangular pyramid: to secure them, another piece of wax, about the size of a grain of wheat, is to be placed midway between the bulb and the points, and secured there by melting it. The very acute points of the needles are to be taken off by light rolling touches upon an oil-stone, and the raggedness, by a little fine emery-paper, so as to produce an obtuse, conical end; the pen, when thus completed, has of course a very fine triangular hole between the needle-points, through which the ink uniformly flows. We have seen some of these pens made by inserting the needles into drilled holes, made in metal, at the end of neat handles, in which the needles were so nearly brought together where they are inserted, as not to need the smaller bulb nearest to the points. The ink flows freely in them, and there is the same facility in using them as a finely-pointed H H H black-lead pencil. They answer well for tracing, as before observed; but we do not think them equal to the common forceps-formed drawing-pen for ruling clear lines.

*Writing-pens*, for common use, are made by doubling a piece of straight together, and rounding the ends, the middle being bellied for the reception of ink. Pens of this description were constantly used for ruling account-books, &c., previous to the introduction of the ruling-machine, which entirely superseded hand-ruling.



Ruling-pens for the machine are made of thin sheet-brass or latten, in long strips, the pens being cut on the edge, and folded together at various distances, according to the pattern to be executed.

*Music-pens* are made for ruling the five staves of music at once; they consist of a parallelogram of brass, terminating in five slit points, communicating with a small reservoir above, in which the ink is placed. They are fitted with a handle, in the hollow of which a small piece of brass is carried for cleaning out the ink passages of the pen. The accompanying engraving shows the construction of this very useful and ingenious apparatus.



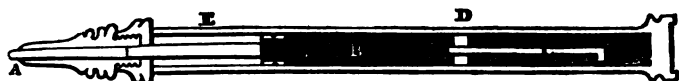
*Dotting-pens*, for writing music, consist of a small brass cylinder, in which a pin of the same material works vertically, being kept down, and projecting about the tenth of an inch, by a spiral spring in the upper part of the pen. An elliptical opening, about halfway up the pen, receives the ink. When placed upon the paper, the brass pin recedes, and causes the ink to make a round black spot on the paper, forming a note,—the tail being supplied afterwards with a common pen.

**PENCIL.** An instrument used by painters for laying on their colours; they are of various kinds. The larger sorts are made of boars' bristles, the thick ends of which are bound to a stick, large or small, according to the uses they are designed for; these, when large, are termed brushes. The finer sorts of pencils are made of camels' hair, also badgers' and squirrels' hair, and of the down of swans; these are tied at the ends by a piece of thread to keep the hair from spreading, and the other ends are enclosed in the barrels of quills of various sizes, suited to the pencil, some of which are of small birds, as those used for drawing lines, and in miniature painting. The usual test of a good pencil is to draw it between the lips, when it should come out with a sharp, conical, and, as it were, solid point.

**PENCIL** is also an instrument used for drawing and writing, made of long slips of black-lead, chalk, or crayon, placed in a groove made in the centre of a stick of wood, usually cedar, on account of the facility of cutting it. The very common black-lead pencils that are hawked about are a composition of powdered black-lead and melted sulphur. Their melting, or softening, or yielding a bluish flame, on application to the flame of a candle, betrays their composition. The genuine black-lead pencils are made of the fine Cumberland plumbago, sawed into slips, fitted into the grooves, and having another piece glued over them. The pure plumbago is, it is said, too soft to enable an artist to make a fine line; to produce this effect, a hard resinous matter is intimately combined with the lead in the following way, which is said to be the invention of Mr. Cornelius Varley. Fine Cumberland lead, in powder, and shell-lac are first melted together by a gentle heat. This compound is then reduced to powder again and re-melted; then powdered again and re-melted, until both substances are perfectly incorporated, and it has acquired a perfectly uniform consistence. The mass is then sawed into slips, and glued into the cedar mountings in the usual manner of making other black-lead pencils. To render them of various degrees of hardness, the materials are differently proportioned; the hardest having the most shell-lac, the softer but very little, and the softest none; and their blackness is increased in proportion to their softness.

Mordan's "ever-pointed pencils" were the subject of a patent granted to Hawkins & Mordan, in 1823. The pencil-case has a slider, actuated by a screw for the purpose of projecting forward a little cylinder of black-lead, as it wears away, which is done by holding the nozzle in one hand, and turning round the pencil-case with the other, the thickness of the lead being so small as not

to need cutting for the ordinary purposes of a pocket-pencil. *Fig. 1* is a section of the pencil-case; A the black-lead or crayon, encompassed by the nozzle, which, with the whole of the case, is made of metal, usually silver. B is the driver, being a hollow cylinder with a screw-thread round a part of it;



at the end of this screw the black-lead is inserted and held fast; C is the elongated part of the driver, which passes through the guide D; at E, within the outer case, is another cylindrical piece, connected to the nozzle at one end, and having at the other a hollow screw that works round on the thread of the driver B, and, as it turns, causes the projector to advance or recede, as may be required. These pencil-cases have had an immense sale, and have been improved upon in a variety of ways during the last ten years.

**PENDULUM.** A vibrating lever or suspended weight. See **HOROLOG.**

**PENSTOCK.** A sluice or floodgate, serving to retain or let go at pleasure the water of a mill-pond.

**PEPPER.** A well-known spice, of which there are three kinds,—the *black*, the *white*, and the *long* pepper; to these we may now add a fourth, *bleached* pepper, a patent process which the black pepper undergoes in this country to render it white.

Black pepper is cultivated with such success at Malacca, Java, and especially at Sumatra, that from these islands pepper is exported to every part of the world where a regular commerce has been established. The ground chosen for a pepper garden is marked out into regular squares of six feet, the intended distance of the plants, of which there are usually a thousand in each garden. The pepper vines are supported by chinkareens, which are cuttings of a tree of that name planted on purpose. Two pepper vines are usually planted to one chinkareen, round which the vines twist for support. After being suffered to grow for three years, they are cut off about three feet from the ground, and, being loosened from the prop, are bent into the earth in such a manner that the upper end is returned to the root. The fruit, which is produced in long spikes, is four or five months in coming to maturity: the berries are at first green, turn to a bright red when ripe and in perfection, and soon fall off if not gathered in proper time. By drying they become black, and more or less shrivelled, according to their degree of maturity.

The common white pepper is the fruit of the same plant, differently prepared. It is steeped in water, and then exposed to the heat of the sun for several days, till the rind or outer bark loosens; it is then taken out, and when it is half dry rubbed till the rind falls off; and the white fruit remaining is dried in the sun. A great deal of the heat of the pepper is taken off by this process, so that the white kind is more fit for many purposes than the black.

The long pepper is a dried fruit, of an inch or an inch and a half in length, and about the thickness of a large goose-quill; it is of a brownish grey colour, cylindrical in figure, and said to be produced on a plant of the same genus. It is a native of the East Indies, especially Java, Malabar, and Bengal. This fruit is hottest to the taste in its immature state, and is therefore gathered while green, and dried by the heat of the sun, when it changes to a blackish or dark grey colour. Dr. Cullen observes, that long pepper has precisely the same qualities with those of black, but in a weaker degree.

The method of preparing the bleached pepper appears to be engrossed by Mr. Fulton, of London, who has taken out two patents, one in 1828, the other in 1830. By the specification of the first we are informed that the common black pepper is steeped in water for a day or two, then laid in heaps, and occa-

sionally turned; fermentation ensues, and in a space of time, varying from a week to a month, the outer or black skin bursts and falls off. The pepper is then bleached by oxymuriate of lime, sulphur, or other well-known means. This done, it is washed, and lastly dried in the air, or in an oven. Black pepper thus metamorphosed, so exactly resembles, it is said, the genuine white pepper as to deceive experienced dealers. In the second patent, Mr. Fulton's claim seems to be in the inverse ratio of his invention; for he has invented, he says, the application of a common groat or barley-mill to the cleansing of pepper from the husks, and he claims the exclusive right to use all sorts of machinery in preparing pepper.

The public should be upon their guard against the quantities of spurious pepper, both whole and ground: the latter is, of course, easily counterfeited; but the manufacture of the former is somewhat ingenious. The pepper dust from the sweepings of warehouses is mixed with oil-cake, and rolled up into little balls resembling pepper.

**PERCUSSION**, *Centre of*, in any body or system of bodies revolving about a point or axis, is that point which, striking an immovable object, the whole mass shall not incline to either side, but rest in equilibrio without acting on the centre of suspension. If a person attempt to strike any object with a straight stick, and do not strike it in the centre of percussion, a considerable jarring will occur, which will not be felt if the blow be given in that point. In a straight stick of equal thickness, the centre of percussion is two-thirds of the length of the stick from the axis of motion. Generally, the distance of the centre of percussion from the centre of motion is equal to the sum of the products of each particle of the body, by the square of its distance, divided by the product of the whole mass by the distance of its centre of gravity from the axis of motion.

**PERCUSSION POWDER.** Take two parts of the chlorate of potash, and one of antimony; they must be separately levigated to an impalpable powder, in a marble mortar, and mixed together with an ivory knife; to granulate it, it must be made into a thick paste, with spirits of wine, in which must be dissolved a little gum mastic to make it adhesive; and, by forcing it through a hair sieve, it will be formed into grains. Four parts of potash, and one of antimony, will detonate; but this mixture was found, after a great number of trials by an eminent chemist, not to be sufficiently strong to be depended upon. See **DETONATING POWDERS.**

**PERPETUAL MOTION** is that which possesses within itself the principle of motion; and, consequently, since every body in nature, when in motion, would continue in that state, every motion once begun would be perpetual but for the operation of some external causes; such as those of friction, resistance, &c.; and since it is also a known principle in mechanics, that no absolute power can be gained by any combination of machinery, except there being, at the same time, an equal gain in an opposite direction; but that, on the contrary, there must necessarily be some lost from the above causes, it follows that a perpetual motion can never take place from any purely mechanical combination; yet this is a problem which has engaged the attention of many ingenious men, from the earliest period to the present time, though it has but seldom been attempted by men of science since the true laws of mechanics have been so well established.

**PERSIAN WHEEL.** See **HYDRAULIC MACHINES.**

**PERSPECTIVE.** The art of delineating objects on any given surface as they would appear to the eye if that surface were transparent, and the objects themselves were seen through it from a fixed situation. Thus, if on looking through a window at any object we were to trace over all the lines of the object on the glass, carefully keeping the eye in precisely the same position all the time, we should make a perspective drawing of the object, and the glass would be termed the plane of delineation. Every true perspective picture is, therefore, an exact copy of the order in which the rays, proceeding from the object represented, would intercept in their passage to the eye a transparent plane at right angles to the direction in which the eye viewed that object;

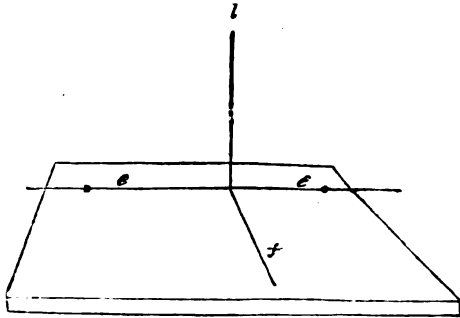
which plane is the plane of delineation of the picture, which is large or small, according to its distance from the eye. It does not form a part of the plan of this work to give a treatise on the art of drawing in perspective; and the foregoing observations have been chiefly made as introductory to the next article.

**PERSPECTIVE INSTRUMENTS.** A mechanical contrivance designed to facilitate the making of drawings in perspective, especially by such persons who are unacquainted with the rules by which it is performed. Some of these instruments are on optical principles, such as the camera obscura, and the camera lucida, already noticed under their proper heads. In praise of the latter much has been lately said, and although it must be admitted to be a very portable and beautiful instrument, the acquisition of the art of using it is extremely difficult to all, and to some persons impossible. Its chief use will be that of affording the means of contemplating the real perspective appearance of objects, and perhaps to obtain the position of a few points, but for very minute delineation it is of little value. One of the simplest mechanical contrivances for taking successively on the perspective plane the various *points* of an object or landscape, and marking them down on paper with accuracy, was long since described by Ferguson, to whom the knowledge of it was communicated by Dr. Bevis. It consisted of an oblong rectangular board, across the middle of which was attached by hinges a movable frame, the sides of which were formed of two equal circular arcs, that met together at the top in the manner of a gothic arch. To the centre of each of these arcs was attached a cord, the other ends of which were fastened to sliding pieces traversing their respective arcs; these cords therefore crossed each other, and by moving the slides to any part of the opposite arcs, the cords might be made to intersect each other at any point in the plane, or space between the arcs. The eye-piece, or hole through which the object to be drawn is viewed, is fixed to a slide in the centre of one end of the board, and the distance between the eye and the plane of delineation may be thus varied to increase or diminish the size of the picture. On that half of the board between the frame, (when the same is turned upright on its hinges,) and the object viewed, the paper to be drawn upon is pinned down. It will now, we think, be plain, that to mark down the exact position of any point in a picture, it is only necessary to move the slides so that the cords shall intersect at that point; having thus found it, the arched frame is then turned down upon its hinges flat upon the board or paper thereon, a mark is then made on the latter at the point of intersection of the cords. Suppose the mark thus made indicates the extremity of the parapet of a building, the slides being then moved so as to intersect the cords at the other extremity, that point is also found, and the frame again turned down to mark it; then by connecting these two points on the paper by a line, the precise inclination and perspective measurement is infallibly correct, and by proceeding to work in this manner, all the outlines of an entire picture may be accurately laid down.

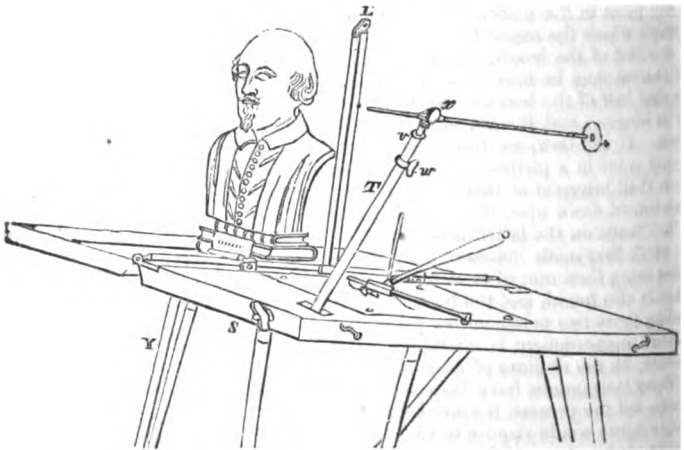
Many instruments have been contrived for finding the various perspective points, but the process, it must be allowed, is extremely slow; even the most simple figure would require to have many points found in it before its outline can be produced; and if it consisted of curved or irregular lines, many more points must be taken in each curve to get a correct delineation.

Mr. F. Ronalds, of Croydon, has, however, contrived and patented an apparatus, by which *the lines themselves, of whatever form or arrangement they may be, may be drawn directly from the object with the same facility as tracing them.* The operation simply consists in causing a small bead to traverse in the plane of delineation, but the bead cannot make any movement whatever without a pencil mechanically attached to it, which traces down on paper, lines precisely corresponding with the figure; in other words, while the bead traverses over the lines of the object, the pencil moving with it does of necessity make an accurate perspective drawing. *Fig. 2,* in the following page, gives a perspective view of one of the forms of the complete instrument in the manner it is used, except that the legs on which it stands are cut off to save space. But in order that the reader may easily comprehend its action, we subjoin the annexed

diagram, illustrative of the principle. The instrument consists of a straight bar  $ee$ , moving horizontally on two rollers attached to the table;  $f$   $l$  are two other bars fixed at right angles to the bar  $ee$ , and to each other, the former



lying on the drawing paper (horizontally), the latter placed perpendicularly in the plane of the picture, all being attached together: if the bar  $f$  be moved to the right or left, the vertical rod  $l$  will slide on the rollers in a vertical plane, or the plane of delineation. To the bar  $f$  is adapted a slider with a pencil, as seen in *Fig. 2*; to this pencil a silk thread is fastened, which passes under a pulley in



the corner where all the bars meet; thence it proceeds upwards, parallel to the bar  $l$ , (at which part it carries the small bead,) and finally passes over a pulley at the top, having a little weight which falls down the bar or tube  $l$  attached to its other end.

It will now be evident, that if we move the slider with the pencil on the horizontal bar, the weight attached to it by means of the silk thread must rise or fall through an equal space, and with it the bead placed upon it; and whether the pencil be moved to the right or left, or along the bar  $f$ , the bead must move in the same direction, but in a plane at right angles to it. Having explained these two motions, it follows that every combination of them, whether in curved or straight lines, must be similarly performed both by the bead and pencil.

In using the instrument, it is requisite to arrange the sight-hole, attached to

the bar T, (through which alone the operator must use his eye in sketching,) and the position of the bead on the thread, so as to get the drawing within the limits of the drawing paper. The handle which is attached to the slider with the pencil by an universal joint, must now be moved about, causing the bead to traverse over every line of the object, which, being marked down by the pencil, we have a fac-simile of the motions of the bead on the plane of delineation. We have in this most ingenious instrument a simple and elegant adaptation of the foundation laws of the science of perspective; it may be called a teacher of perspective as well as a perspectograph. These instruments are constructed of various sizes, and packed in cases, including a book of instructions, at very moderate charges. They are manufactured by Messrs. Holtzapfell, of Charing Cross, in the best style of workmanship.

**PETRIFACTIONS.** Stony matters deposited either in the way of incrustation, or within the cavities of organized substances, are called petrifications. Calcareous earth being universally diffused, and capable of solution in water, either alone, or by the medium of carbonic acid or sulphuric acid, which are likewise very abundant, is deposited whenever the water or the acid becomes dissipated. Incrustations of limestone or of selenite, in the form of stalactites, or dropstones, are formed in this way, from the roofs of caverns, and in various other situations. Some remarkable observations relating to petrifications are thus given by Kirwan :—

1. That those of shells are found on or near the surface of the earth; those of fish deeper, and those of wood deepest. Shells in specie are found in immense quantities at considerable depths.
2. That those organic substances that resist putrefaction most are frequently found petrified, such as shells and the harder species of woods: on the contrary, those that are aptest to putrefy are rarely found petrified, as fish, and the softer parts of animals, &c.
3. That they are most commonly found in strata of marl, chalk, limestone, or clay, seldom in sandstone, still more rarely in gypsum, but never in gneiss, granite, basaltes, or shori; but they sometimes occur among pyrites, and ores of iron, copper, and silver, and almost always consist of that species of earth, stone, or other mineral that surrounds them, sometimes of silix, agate, or carnelian.
4. That they are found in climates where their originals could not have existed.
5. That those found in slate or clay are compressed and flattened.

**PETROLEUM.** A fluid bitumen, of somewhat greater consistence than asphalt, of a black, brown, or sometimes dingy green colour. By exposure to the air, it assumes the consistence of tar, and is then called *mineral tar*. This substance exudes spontaneously from the earth, or from clefts of rocks, and is found nearly in all countries. Near Rangoon, in Pegu, there are several hundred wells of petroleum, which are carefully preserved, and yield annually 400,000 hogheads. At Colebrook-dale, in Shropshire, there is a considerable spring of petroleum, from which large iron pipes are employed to convey it into pits sunk to receive it. From these pits it is conveyed into caldrons, in which it is boiled until it attains the consistence of pitch. Since the first discovery of this substance, three different springs of it have broken out: one of these is near the celebrated iron bridge, and the fluid which issues from it is almost pellucid, but, at the same time, thicker than treacle. Petroleum easily takes fire, and in burning yields a strong, sharp, and somewhat unpleasant odour; a thick and disagreeable smoke. In cold weather it congeals in the open air. It is used instead of oil for lamps in some places; also, when combined with various matters, in painting timber, and is supposed to check and prevent the future ravages of the worm upon the bottoms of ships coated with it.

**FEWTER**, which is commonly called *étain* in France, and generally confounded there with true tin, is a compound metal, the basis of which is tin. The best sort consists of tin, alloyed with about a twentieth or less of copper, or other metallic bodies, as the experience of the workmen has shown to be the most conducive to the improvement of its hardness and colour, such as lead, zinc,



bismuth, and antimony. There are three sorts of pewter, distinguished by the names of plate, trifle, and ley-pewter. The first was formerly much used for plates and dishes; of the second are made the pints, quarts, and other measures of beer; and of the ley-pewter, wine measures, and large vessels. The best sorts of pewter consist of 17 parts of antimony to 100 parts of tin; but the French add a little copper to this kind of pewter. A very fine silver-looking metal is composed of 100 pounds of tin, 8 of antimony, one of bismuth, and four of copper. On the contrary, the ley-pewter, by comparing its specific gravity with those of the mixture of tin and lead, must contain more than a fifth part of its weight of lead.

**PHANTASMAGORIA.** The exhibition called by this name is performed by means of a magic lantern, constructed on a large scale. In the common magic lantern the figures are painted on the glass, and all the rest of the glass is left transparent; but in the phantasmagoria the whole of the glass is made opaque, except the space taken up by the figures painted with the transparent colour; hence this difference in the effect is produced, that no light falls upon the screen but what passes through the figures themselves, consequently there is no circle of light, nor any thing but the figures on the screen. Let the door of a darkened room in which the exhibition is to be seen be set wide open, and its place supplied with a screen of thin silk, or fine linen, or of paper rendered transparent. From the outside of the room let the pictures, painted as above described, be thrown upon the screen, of a very minute size. They will immediately be seen within the room, and, though remarkably brilliant, they will be supposed to be distant by the spectators, because they see nothing but the light which comes from them. If the lantern be drawn back to a greater distance from the screen, the images become gradually enlarged, and appear to approach the spectators, and seem pendant in the air.

**PHARMACY.** The art of preparing, compounding, and preserving medicines. The established and authorized modes of practising this important art, are to be found in those books called pharmacopœias.

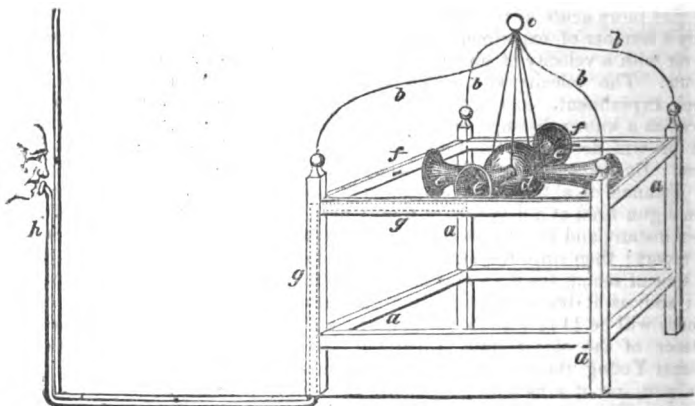
**PHAROS.** A name sometimes given to a lighthouse, from the circumstance of the first being built at Pharos, near Alexandria. See **LIGHTHOUSE.**

**PHONICS, or ACOUSTICS.** A science which treats of the nature and mode of propagation of sound. Whenever any elastic body is made to vibrate, it produces corresponding vibrations in the air surrounding it; these acting on the ear, cause its internal parts to vibrate and excite in us the sensation of sound. From the necessity of air to the conveyance of sound in ordinary experiments, the phenomena of sound have usually been considered as forming part of the science of Pneumatics; but the entire difference of its results, and its connexion with elastic bodies generally, sufficiently justify its claim to a separate denomination. That sound cannot be conveyed from one part of space to another without some material connexion, is well ascertained, and may, to a certain extent, be proved, by suspending a bell within a glass receiver of the air pump, and exhausting the air; it will then be found that as the air is withdrawn, the sound of the bell becomes more and more feeble, so that, at last, it is scarcely audible. That air is not the only conductor of sound may be shown by various experiments. If a heavy mass of iron, as a kitchen poker, be suspended by a piece of twine, the two ends of which are pressed against the ears, and the poker be then struck against any metallic substance, as a fender, a sound will be heard of so great intensity as to resemble the tolling of a bell. If two stones are struck against each other under water, the sound may be heard at a great distance by plunging the head beneath the surface of the water: Dr. Franklin affirms that he has heard it in this way at the distance of half a mile. Sounds are also transmitted to great distances through solid bodies. If a slight scratch be made at one end of a long piece of timber, and the ear be applied to the other, a distinct sound will be heard. In this manner miners hear the sounds made of their fellow-workmen, and thus judge of their direction. If a person be placed at one end of a series of metallic tubes, the blows of a hammer at one extremity are heard distinctly at the other, two sounds being heard, one conducted by the air, and the other by the metal. To show that

sound is really the effect of vibrations in the bounding body, carried to a certain degree of rapidity, a long string, or wire, may be stretched by a small weight; the vibrations at first will be distinctly seen, and may be counted; but in this case they produce no perceptible sound. If the weight which extends the cord be increased, the vibrations become more rapid, and a sound is heard which becomes more acute as the string is more stretched.

By a number of experiments it has been found that sound travels through the air with a velocity of about 1140 feet in a second, or nearly 13 miles in a minute. The velocity with which sound travels may be easily proved by a simple experiment. Let a gun be fired at a given instant, and let a person placed at a known distance, observe the time elapsed before he hears the report, and this will determine the time the sound has been travelling over the given space. By knowing the velocity with which sound travels, we may ascertain the distance of a thunder-cloud, or of a ship in distress. Suppose the light from a gun fired at a distance, or from a flash of lightning to be observed at a given instant, and that five seconds elapse between seeing the flash and hearing the report; then since the motion of light may be considered as instantaneous, the time of seeing the flash may be taken as the instant at which the sound sets out; and as it travels 1142 feet in a second, the space passed over in five seconds will be  $1142 \times 5 = 5710$  feet, or 1 mile and 430 feet, which will be the distance of the object from which the sound proceeds. According to Dr. Thomas Young, the velocity of sound, on an average, is 1130 feet. The sound of a gun, or of a hammer, is equally swift in its motion; the softest whisper flies as swiftly as the loudest thunder. The equal velocity of the different tones was beautifully shown by Biot in experiments on the pipes of the aqueducts at Paris, a distance of about 3000 feet; an air was played on a flute at one extremity, and listened to at the other end, and the time was perfectly preserved; and hence the equal velocity of the various notes was demonstrated. Different substances transmit sound with different velocities. If the velocity in air be represented by 1, the velocity in rain-water will be  $4\frac{1}{2}$ , in sea-water  $4\frac{1}{6}$ , and in brass  $10\frac{1}{2}$ . The velocity of sound is uniform. The strength of sounds is greatest in cold and dense air, and least in that which is warm and rarefied. Every point against which the pulses of sound strike becomes a centre, from which a new series of pulses is propagated in every direction. Sounds may be reflected like light, and thus form what is termed an echo. For the most powerful echo the sounding body should be in one focus of the ellipse, which is a section of the echoing spheroid, and the hearer in the other. An echo may, however, be heard in other situations, though not so distinctly. Thus a person often hears the echo of his own voice; but for this purpose he should stand at least 63 or 64 feet from the reflecting obstacle. At the common rate of speaking, we pronounce about seven syllables in a second; in order, therefore, that the echo may return just as soon as three syllables are expressed, twice the distance of the speaker from the reflecting surface must be equal to 1000 feet; for as sound describes 1142 feet in a second, six-sevenths of that space, that is, 1000 feet nearly, will be described, while six, half, or three whole syllables are pronounced; that is, the speaker must stand nearly 500 feet from the obstacle. In general, the distance of the speaker from the echoing surface for any number of syllables must be equal to the seventh part of the product of 1142 feet multiplied by that number. When the walls of a passage, or of an unfurnished room, are smooth and perfectly parallel, any explosion, or a stamping with the foot, communicates an impression to the air, which is reflected from one wall to the other, and from the second to the ear, by which reverberation the primitive sound is greatly increased in intensity. Sound, like light, may be reflected from several places, and collected in one point as into a focus, and it will be there more audible than at the place from whence it proceeded. On this principle the whispering gallery is constructed, the form of which must be that of a concave hemisphere. Somewhat similar is the effect of speaking and hearing trumpets, which, by reverberating the sounds uttered through them, increase their intensity. By means of an arrangement of these, a deceptive acoustic experiment was exhibited, an idea of which may be formed by the following

sketch. It was pretended that the invisible girl was within the ball *d*; and whenever a person, by applying his mouth to either of the trumpets *e*, put a question, an answer was returned which seemed to proceed from the ball, in the



centre of which the invisible being was supposed to reside. A reference to the cut will explain the manner in which the illusion was accomplished. The upper part of the frame-work is hollow; and by means of the tube *g g*, passing through the leg of the apparatus and floor of the room into another chamber, communicates with another individual *h*, who is to represent the invisible girl. When a person is desirous of trying the experiment, he applies his mouth to either of the trumpet-mouths *e e e*, and puts his question; the sound so uttered is reflected so as to pass through the holes *f f*, and through the pipe *g g* to *h*, where it is heard by the person who is then listening. A reply is then given through the tube *h g g*, which, coming out through the hole *f*, is received in the trumpet-mouths, and reflected to the ear of the inquirer at *e*. The trumpets being suspended by silken strings, no visible connexion appears between the place whence the sound seems to proceed, and the individual who is the author of it; the illusion is therefore complete.

**PHOSPHATES.** Salts formed by the phosphoric acid with the alkalis, earths, and metallic oxides. The phosphates at present known amount to twelve, two of which are triple ones.

**PHOSPHITES.** Salts formed with the phosphorous acid united to the earths, alkalis, and metallic oxides.

**PHOSPHORIC ACID.** The base of this acid, or the acid itself, abounds in the mineral, vegetable, and animal kingdoms. In the mineral kingdom it is found in combination with lead in the green lead ore; with iron in the bog-ores, which afford cold-short iron; and more especially with calcareous earth in several kinds of stone. Whole mountains in the province of Estramadura, in Spain, are composed of this combination of phosphoric acid and lime. In the animal kingdom it is found in almost every part of the bodies of animals which are not considerably volatile: there is not, in all probability, any part of these organized beings which is free from it. It has been obtained from blood, flesh, both of land and water animals; from cheese; and it exists in large quantities in bones, combined in calcareous earth. Urine contains it not only in a disengaged state, but also combined with ammonia.

**PHOSPHOROUS ACID** is prepared by exposing phosphorus during some weeks to the ordinary temperature of the atmosphere. Even in winter the phosphorus undergoes a slow combustion, and is gradually changed into a

liquid acid. For this purpose it is usual to put small pieces of phosphorus on the inclined side of a glass funnel, through which the liquor that is formed drops into the bottle placed to receive it. From an ounce of phosphorus about three ounces of acid liquor may be thus prepared.

**PHOSPHORUS.** A substance which shines by its own light. The discovery of this singular substance was accidentally made in 1677, by an alchemist of Hamburgh, named Brandt, when he was engaged in searching for the philosopher's stone. Mr. Boyle is also considered to have discovered it; he communicated the process to Godfrey Hankwitz, an apothecary of London, who, for many years, supplied Europe with phosphorus; and hence it went under the name of English phosphorus. In the year 1774 the Swedish chemists, Gahn and Scheele, made the important discovery, that phosphorus is contained in the bones of animals; and they improved the process for procuring it. The most convenient process for obtaining it seems to be that recommended by Fourcroy and Vauquelin, which we shall transcribe. Take a quantity of burnt bones, and reduce them to powder: put 100 parts of this powder into a porcelain or stone-ware basin, and dilute it with four times its weight of water; 40 parts of sulphuric acid are then to be added in small portions, taking care to stir the mixture after the addition of every portion. A violent effervescence takes place, and a great quantity of air is disengaged. Let the mixture remain for twenty-four hours, stirring it occasionally to expose every part of the powder to the action of the acid. The burnt bones consist of the phosphoric acid and lime; but the sulphuric acid has a greater affinity for the lime than the phosphoric acid. The action of the sulphuric uniting with the lime, and the separation of the phosphoric acid, occasion the effervescence. The sulphuric acid and the lime combine together, being insoluble, and fall to the bottom. Pour the whole mixture on a cloth filter, so that the liquid part, which is to be received in a porcelain vessel, may pass through. A white powder, which is the insoluble sulphate of lime, remains on the filter. After this has been repeatedly washed with water, it may be thrown away; but the water is to be added to that part of the liquid which passed through the filter. Take a solution of sugar of lead in water, and pour it gradually into the liquid in the porcelain basin; a white powder falls to the bottom, and the sugar of lead must be added so long as any precipitation takes place. The whole is to be again poured upon a filter, and the white powder which remains is to be well washed and dried: the dried powder is then to be mixed with one-sixth of its weight of charcoal powder. Put this mixture into an earthenware retort, and place it in a sand bath, with the beak plunged into a vessel of water; apply heat, and let it be gradually increased till the retort becomes red hot. As the heat increases, air-bubbles rush in abundance through the beak of the retort, some of which are inflamed when they come in contact with the air at the surface of the water. A substance at last drops out similar to melted wax, which congeals under the water; this is phosphorus. To have it quite pure, melt it in warm water, and strain it several times through a piece of chamois leather, under the surface of the water. To mould it into sticks, take a glass funnel with a long tube, which must be stopped with a cork; fill it with water and put the phosphorus into it: immerse the funnel in boiling water, and when the phosphorus is melted and flows into the tube of the funnel, then plunge it into cold water; and when the phosphorus has become solid, remove the cork and push the phosphorus from the mould with a piece of wood. Thus prepared, it must be preserved in close vessels containing pure water. When phosphorus is perfectly pure it is semi-transparent, and has the consistence of wax: it is so soft that it may be cut with a knife. Its specific gravity is from 1.77 to 2.03. It has an acid and disagreeable taste, and a peculiar smell, somewhat resembling garlic. When a stick of phosphorus is broken, it exhibits some appearance of crystallization. The crystals are needle-shaped, or long octahedrons; but to obtain them in their most perfect state, the surface of the phosphorus, just when it becomes solid, should be pierced, that the internal liquid phosphorus may flow out, and leave a cavity for their formation. When the phosphorus is exposed to the light it becomes of a reddish colour, which appears to be an incipient combustion. It

is therefore necessary to preserve it in a dark place. At the temperature of  $90^{\circ}$  it becomes liquid; and if air be entirely excluded, it evaporates at  $219^{\circ}$ , and boils at  $554^{\circ}$ ; at the temperature of  $43^{\circ}$  or  $44^{\circ}$  it gives out a white smoke, and is luminous in the dark; this is a slow combustion of the phosphorus, which becomes more rapid as the temperature is raised. When phosphorus is heated to the temperature of  $148^{\circ}$ , it takes fire, burns with a bright flame, and sends out a great quantity of white smoke. Phosphorus enters into combination with oxygen, azote, hydrogen, and carbon; it is soluble in oils, and, when thus dissolved, forms what has been called liquid phosphorus, which may be rubbed on the face and hands without injury; it dissolves, too, in ether, and a very beautiful experiment consists in pouring this phosphoric ether in small portions, and in a dark place, on the surface of hot water. The phosphoric matches consist of phosphorus, extremely dry, minutely divided, and perhaps a little oxygenized. The simplest mode of making them is to put a little phosphorus, dried by blotting-paper, into a small phial; heat the phial, and when the phosphorus is melted, turn it round, so that the phosphorus may adhere to the sides. Cork the phial closely, and it is prepared. On putting a common sulphur-match into a bottle, and stirring it about, the phosphorus will adhere to the match, and will take fire when brought into the air.

**PHOSPHURETS.** Substances formed by an union of the alkalies, earths, and metallic oxides, with phosphorus. Thus we have phosphuret of lime.

**PHOTOMETER.** An instrument designed to exhibit the different quantities of light, especially in bodies illuminated in different degrees. In Lesslie's photometer, the essential part is a glass tube, like a reversed syphon, whose two branches should be equal in height, and terminated by balls of equal diameter: one of the balls is of black enamel, and the other of common glass, into which is put some sulphuric acid, tinged with carmine. The motion of the liquid is measured by means of a graduated scale; the zero is situated towards the top of the branch that is terminated by the enamelled ball. The use of this instrument is founded upon the principle, that when the light is absorbed by a body, it produces a heat proportional to the quantity of absorption. When the instrument is exposed to the solar rays, those rays that are absorbed by the dark colour heat the interior air, which causes the liquor to descend at first with rapidity in the corresponding branch. But as a part of the liquor which had introduced itself by means of the absorption is dissipated by radiation, and as the difference between the quantity of the heat lost and that of the heat acquired goes on diminishing, there will be a point where (these two points having become equal) the instrument will be stationary, and the intensity of the incident light is then estimated by the number of degrees which the liquor has run over.

Mr. Ritchie, of Nain, has constructed a very simple photometer, on the principle of Bougier. It consists of a rectangular box, about an inch and a half or two inches square, open at both ends, and blackened within for the purpose of absorbing irregular light. Two rectangular pieces of plain mirror are placed within the box, at right angles with each other, and at an angle of  $45^{\circ}$  with the sides of the box. A rectangular opening is cut in the upper side or lid of the box, about an inch long and an eighth broad, and, passing over the line formed by the intersection of the two mirrors, is half over the one and half over the other; the aperture is to be covered with a slip of fine tissue, or oiled paper. When used, it is to be placed in the same straight line, between the two flames to be compared, they being distant six or eight feet from each other, and is to be moved until the disc of paper is equally illuminated by the two flames. The illuminating powers of the two flames will then be directly as the squares of their distances from the middle of the photometer. In viewing the illuminated disc, it is well to look at it through a prismatic box, about eight inches long blackened within, to absorb strong light. Sometimes, instead of using mirrors and the paper-screen, the



inclined planes are covered with white paper, and looked at directly through the aperture. However the instrument be used, a mean of several observations should be taken, the instrument being turned round each time. When the lights are of different colours, the plan Mr. Ritchie recommends is, to cover the rectangular opening in the instrument with a piece of fine white paper, printed distinctly with a small type; the paper is to be brushed over with oil, and then the instrument being placed between the lights, they are to be moved till the printing can be read continuously along the paper with equal ease on the one side as on the other. In the second form, the printed paper is to be pasted on the mirrors, or the inclined surfaces against which they lie, and is then to be read through the opening. It is advantageous to enlarge the openings in these applications of printed paper.

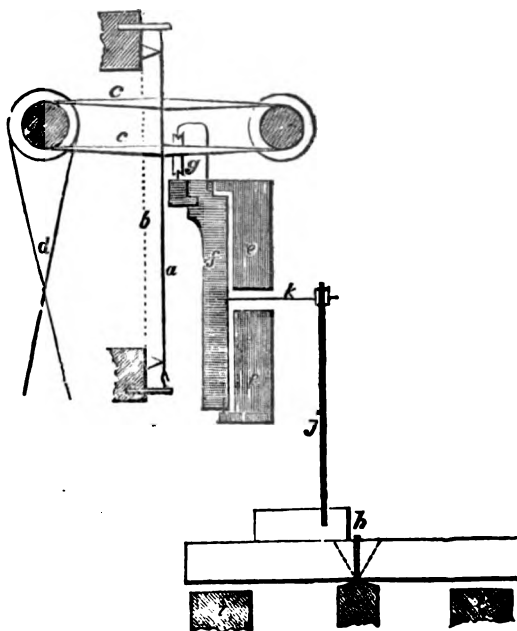
**PIANO-FORTE.** A musical instrument, resembling the harpsichord, (of which it is an improvement,) in which the tone is produced by hammers, instead of quills, upon the strings. Of all the keyed instruments, as observed in the *Oxford Encyclopædia*, the piano-forte seems to merit the preference, on account of the superior tone, sweetness, and variety, of which, by the ingenuity of British artists, it has now become susceptible. It was, as early as the beginning of the last century, that hammer-harpsichords were invented at Florence, of which there is a description in the *Giornale d'Italia*, 1711. The invention made but a slow progress; the first that was brought to England was by Father Wood, an English monk at Rome. The tone of this instrument was so superior to that produced by quills, with the additional power of producing all the shades of piano and forte by the finger, that though the touch and mechanism were so imperfect that nothing quick could be executed upon it, yet the Dead March in Saul, and other solemn and pathetic strains, when executed with taste and feeling, by a master a little accustomed to the touch, excited equal wonder and delight in the hearers. Backers, a harpsichord-maker, constructed several piano-fortes; and although he improved the mechanism in several respects, he failed in the tone. After the arrival of John C. Bach in this country, and the establishment of his concert, in conjunction with Abel, all the harpsichord-makers tried their mechanical powers upon piano-fortes; but the first attempts were always on the large size, till Zumpé, a German, constructed small piano-fortes, of the shape and size of the original, of which the tone was very sweet, and the touch, with a little use, equal to any degree of rapidity. Pohlman, whose instruments were very inferior in tone, fabricated a great number for such persons as Zumpé was unable to supply. Large piano-fortes afterwards received great improvements in the mechanism by Merlin, and, in the tone, by Broadwood, Stoddart, Clementi, and others. The harsh scratching of the quills of a harpsichord can now no longer be borne. A great number of improvements have been made of late years, which have been the subjects of numerous patents. Some of these we now proceed to notice.

The first which presents itself to our attention is the patented improvement of Mr. Wheatstone, of Jermyn-street, for augmenting the tone by the introduction of drums, or similar vibrating surfaces, against which the sounds elicited re-ferberate; these, it is said, not only augment the tone, but improve the melody. For this purpose, wooden frames are fitted to the inside of the instruments, upon which is tightly stretched paper, parchment, vellum, or similar substances, which constitute the drum. These, being placed as near as possible to the sounding-boards of the instruments, are powerfully acted upon by the vibration of the notes given out; and to conduct the sound elicited with greater effect to the ears of the auditory, trumpet-shaped apertures are made through the cases of the instruments.

To give to piano-fortes the rich and lengthened tones of the violin, a patent was taken out by Mr. Todd. This is effected by the pressure of the foot of the player upon a pedal, which puts in motion an endless band (furnished with powdered resin), which is made to rub against the particular wire in connexion with the key that is depressed by the finger of the player; and thus the same effect is produced as by the bow over the strings of the violin. Instruments constructed will therefore have two distinct sets of tones; that is, when the

pedal is acted upon, the lengthened and beautiful tones of the violin will be produced; without it, those of the ordinary piano.

The invention is not, however, confined to piano-fortes, but to all other instruments wherein the sounds are produced by the vibration of wires, or strings of catgut; but the most eligible instrument for its application, is the piano, more especially those of the upright or cabinet kind. The annexed diagram we have therefore selected from the specification, to explain the construction and modes of action of this ingenious contrivance, when applied to piano-fortes of the latter description. The figure gives a vertical section of the part; thus *a* shows one of the wires stretched across the bridges, by means of tension pins over the body of the instrument. *cc* is an endless band revolving



over two cylinders, which are set in motion by the treadle *d*, operated upon by the pedal; this band is to be made of cloth, catgut, or other material capable of holding powdered rosin. *ee* is a frame of wood on which is made to turn a swinging piece *f*, and there are as many of these frames and swinging pieces as there are keys to the instrument. On each swinging piece are fixed wires, bent in the manner shown; their ends are reduced to a conical figure to form centres, upon which revolve small brass rollers, as that at *g*. *h* is one of the keys of the instrument moving on its fulcrum pin, and its two stops are shown at *i*; a vertical stem of wood *j* is fixed into the key, carrying above it, in a horizontal position, a wire *k*, which acts upon the swinging piece *f*; the wire *k* is fixed to the stem *j* by means of nuts placed on either side of the stem, which screw on to the end of the wire, and by these means the extent of motion to be given to the swinging piece is regulated. It will now be seen that when any key *i* is depressed by the finger of the player, the little brass roller *g* is pressed against the endless band, which, bending it a little out of the right line, causes it to rub against the wire *a*, and thereby produce a similar effect to the drawing of the bow over the strings of a violin.

The next invention which we shall notice is that of Mr. James Stewart, of George-street, Euston-square, who had a patent for it in 1830. It will be observed that there are several motions connected with the operations of a piano which require great precision as to their time, duration, and intensity of action. The hammer must be made to strike the string at the same instant that the damper is withdrawn, and the hammer having done its duty must be instantly removed (even before the finger of the performer has left the key,) from the string, to allow the vibration to take place, and then the damper must return to stop the vibration of the string the moment that the finger is withdrawn from the key. Now as all the motions must be obtained by a very slight touch of the finger, and without any noise, the levers and connecting rods, by which they are transmitted from the keys to the strings, become important considerations with piano-forte makers, and Mr. Stewart has simplified the action, and rendered it more certain, by the introduction of a short lever placed over, and parallel with the interior end of the finger lever. This lever being short, and joined near its movable end by a small connecting brass rod to the finger lever, furnishes in itself the required variety of motions, by placing the rods which act upon the hammer, damper, &c. at different distances from the fulcrum on which it turns. In addition to this, Mr. Stewart has introduced an improved inclined plane for receiving the tail of the hammer, and stopping it silently, after it has struck the string.

To obviate the objections which have been raised to the elevated casing of the upright or cabinet piano-fortes, especially those whose fronts are covered with silk, which have a tendency to deaden the voice in case of accompaniment, Mr. Simon Thompson, of Yarmouth, has contrived to obviate the necessity of any portion of the instrument rising above the locking board, so that the top of the instrument is flat like a table. This object he effects by lowering the string frame, till its upper surface coincides with the top of the locking board, and making the keys bent levers, turning twice at right angles between the fulcrum on which they move, and the extremities which act upon the hammers. On the inner ends of each key, rests an upright guide wire, or slight rod, and to this are attached various projecting pieces which actuate the hammers, the dampers, &c. much in the usual manner; so that this improvement, which is a very important one, is obtained without in the smallest degree altering the other parts of the instrument.

The spirit of improvement in this interesting branch of art seems recently to have equally pervaded our transatlantic brethren. In the *Journal of the Franklin Institute*, (which contains accounts of all the American patents,) we observe one by Mr. Jesse Thompson, of New York, dated October, 1830, for an improvement in the action of the upright piano-forte, some points in which our own manufacturers may deem worthy of adoption in a modified form. The following claim attached to the specification of this patent, will give to those acquainted with the subject a general idea of the variations introduced in this action. "What I claim as new, and as my own invention, is, first, the application of the finger lever directly to the foot of the connecting rod, dispensing with the jack, springs, and all intermediate gearing. By this more immediate operation of the finger on the hammer, no time is lost between the touch and the blow; the action is more controllable by the finger; the blow is quicker, and more powerful; the hammer can never block; it relieves less from the string, and requires much less depth of touch. The simplicity of its construction renders the work much cheaper, and less liable to get out of order, than any known action. From this perfection of the action, I have been able to render the span of the natural action to six and a half inches, and the others in proportion, without in any degree interfering with a clear and rapid execution: or the common span of the octave may be retained. Second, the placing the dampers below the hammer rail, by which position the dampers fall on the brass strings near the middle of them, and thus more instantaneously and effectually stop their vibration, and may be raised by the simpler and cheaper modes herein specified."

The introduction of cast iron into the framing of piano-fortes, in lieu of the cumbersome masses of wood previously used, to resist the powerful tension of so many wires, was a great modern improvement, to which we believe we stand



indebted to M. Pleyel and Co., of Paris. At the present time the substitution of metal for wood is general.

This part of the mechanism was considerably improved by Mr. J. C. Schwieso, of Regent-street, for which he obtained a patent in 1831. The string board of the piano-forte is secured between a stout cast iron frame, and to the latter is cast a projecting plate, through which the tuning pins pass. These tuning pins are made of steel, their lower ends are turned cylindrical, for coiling the ends of the wire, and the upper ends are made square for the reception of the key. To give these tightening pins the requisite friction to retain any required degree of tension on the strings, and enable them to be turned with facility, they are tapped below the square head to receive a nut, which screws against the upper side of the projecting plate, and they have underneath a collar and washer, which are drawn against the plate by the action of the nut above, leather washers being also interposed to give a degree of elasticity to the bearing parts. To produce the requisite friction, the nuts are screwed up; and in order that the pins may be turned at pleasure, without altering the friction by which they are held, each nut is perforated with two holes, and the square key which fits over the square heads has at its extremity two projecting pins, which enter the holes in the nuts, and therefore turn the pins and nuts together without altering the friction. Mr. Schwieso applies tightening pins of this kind to the harp and violin.

Since the introduction of cast-iron frames for piano-fortes, considerable expense has been incurred in drilling the holes for, and fitting in the pins, so as to give them the properties mentioned in Mr. Schwieso's patent. To remedy these inconveniences, Mr. W. Allen, of Catherine-street, Strand, casts two dovetailed grooves along that end of the frame where the tightening pins are to be inserted, into which he drives pieces of wood of a corresponding shape, to fill up the dovetailed grooves, and to receive the tuning pins. It is evident, that by this ingenious and simple contrivance, the expense of manufacture will be diminished, and the instruments will be improved.

*Self-acting Piano-fortes* have of late years been introduced: they combine the most rapid and brilliant execution with distinctness and neatness. Their harmony is necessarily more full than can be produced by eight fingers, the elements of chords having no other limit than the extent of its scale; the time cannot be otherwise than perfectly equable throughout, yet where pathos is to be expressed, the time can be accelerated or retarded in any degree.

The mechanism of a self-acting piano-forte usually or principally consists of a cylinder turning horizontally on its axis, acted upon by a coiled spring, and regulated by a fly-wheel. On the surface of the cylinder, a determined arrangement of brass pins is formed, each of which, in passing under a rank of levers, elevates one end of the required lever, and depresses the other. The depressed end pulls down with it a slender rod, which is connected by a slide with the tail of a bent lever, on the further end of which is the hammer which strikes the string. The slide can be shifted further from, or nearer to the axis, on which the hammer lever turns, and thus the stroke of the hammer is made feeble or strong to any required degree. When wound up, the instrument will continue to play for a considerable time; and it is provided with a bench of keys like the ordinary piano-forte, so that a person may accompany the instrument, or play a duet with it.

A very beautiful instrument of this kind we have seen, that was manufactured by Clementi and Co.; it had two barrels, each of which played nine tunes. The velocity was regulated by two revolving balls, similar to the governor of a steam-engine.

Messrs. Rolfe and Sons, of Cheapside, have distinguished themselves in this branch of art by several improvements, which were the subject of a recent patent. These improvements they divide into three sections; and their self-acting piano-fortes are constructed either with the first section only, or with the first and second section combined, or with the three sections united. The first section consists of a new apparatus for effecting the transitions of *forte* and *piano*, by which means the difficulty of producing those desirable changes is removed, by transferring the mechanical action from the weakest and most uncertain part of the arrangement, viz. the cylinder, to the more powerful and certain action of the engine, by which

transfer the liability to derangement in instruments intended for exportation is avoided. To this branch of their patent, Messrs. Rolfe and Sons have annexed a hand movement, or register, by which the existing arrangement, or distribution of *forte* and *piano*, may at any time be changed, or altered to suit particular views, or may at any moment be removed from the government of the self-acting apparatus which produces the effect, and be operated upon by the hand, and again be restored to the control of the machine, at pleasure.

The second section consists of a new barrel movement for changing the tunes, which is effected by the introduction of an inclined plane, which forms an abutment for the axis of the cylinder. This plane is divided into eight portions, and is moved by a radial lever upon a pinion, which by its rotation one revolution moves upon a second dial an index to the extent of one eighth of its circumference, moving the inclined plane to a proportionate extent. By this simple arrangement the motions are rendered very steady and accurate, and eight distinct airs may thus be performed.

The third section consists in the application of a set of dampers to the self-performing action, which are altogether independent of the dampers; so that each note of the self-acting or mechanical part of the instrument, in common with each particular note of the finger action, possesses its appropriate damper, connected with and identified by its kindred note, hammers, or keys, and acting simultaneously therewith. In conjunction with the application of the mechanical dampers, suitable staples are introduced into the cylinders, which, acting upon each particular damper as occasion may require, suspends its operation, and enables them to retain the vibration of any given note, or the root and relative intervals of harmonious combinations, in the same manner as the finger of a performer sustains the vibration of chords, whose existence is to be prolonged by continued pressure of the keys, according to the duration expressed by the determined value given to them by the author in the composition performed. In addition to this, the whole set of mechanical dampers are occasionally raised by the cylinder, according to circumstances, in order to produce the effect, or full swell, of the open pedal when moved by the foot of the performer.

**PIER.** A strong erection jutting into the sea, for affording shelter to shipping and small craft, or for the convenience of landing goods and passengers. For the former purpose they are usually constructed of very massive and durable materials, wrought together in the most solid manner; such as immense stones, dovetailed into each other, and cramped with iron, being supported on the outside by large piles driven into the ground, and strongly framed together by several rows of cross pieces. A rocky point is generally chosen (if to be obtained) for joining the pier to the land; the other end is extended out into the sea, either in a right line or a curve, but more generally the latter, to form an enclosed harbour for shipping within the curve. Breakwaters are more frequently in straight lines; chain-piers are also straight, as that at Brighton: the construction of these is precisely similar to suspension bridges. See BRIDGE.

**PIERS, of a Bridge.** The walls or masses from which the arches spring.

**PIERS, in Building and Architecture.** The wall interposed between two windows; also the buttresses or masses of wall raised to strengthen buildings.

**PILE-ENGINE.** A machine for driving piles into the ground, to make a solid foundation for buildings, the construction of piers, wharfs, &c. As these engines are of every-day observation, and are figured in all previous works of this nature, we shall confine ourselves to a brief verbal description. By means of the mechanism of a common crane, a heavy iron weight, called the *ram*, is raised perpendicularly between two lofty guides of timber, framed together at the top and laterally, clear of the ram. Just as the ram attains to its highest elevation, a projecting lever from the hook to which the ram is suspended meets with a fixed obstruction to its upward passage, that bends the lever downwards, and thus unhooks the ram, which, falling from a great height, strikes the head of the pile with tremendous force, driving it into the ground. The hook and chain now descend, and the hook, coming in contact with the top of the ram, locks itself thereto again by means of a spring or lever-catch, when it is drawn up again to repeat the operation.

**PIN.** A well-known little instrument, chiefly used to adjust or fasten the clothes of women and children. Although consisting of merely a piece of wire, with a head and a point, great mechanical ingenuity has been exercised to perfect its construction at a cheap rate; but such is the extent of the consumption, and consequent importance of the manufacture of pins, that there are many establishments where upwards of two tons, containing about 20,000,000 in number, are made weekly. The *ordinary* method of making pins has been thus described by various authors on the subject. Brass wire, drawn to the required size, is straightened by drawing it between steel pins, set in a zigzag form upon a bench, and afterwards cut into such lengths as will each make six pins of the required size. These lengths are pointed at the ends by boys, who sit each with two small grindstones before him, turned by a wheel. Taking up a handful, he applies the wires to the coarsest of the two stones, moving them round at the same time, and in such a position as to produce evenly-rounded and well-tapered conical points, which are perfected and sharpened by him afterwards upon the smoother stone. A lad of twelve years of age will thus point 16,000 in an hour. The length of a pin is then cut off each end of the pointed wire, and the remaining portion of wire is treated in a similar manner, successively, until the six pins of each length have been pointed. The next operation is heading, or rather "head-spinning;" the heads being prepared for subsequent putting on, by winding a finer wire around another wire of the size of the pin, by the rapid revolution of a kind of spinning-wheel. The internal wire being drawn out leaves the external wire of the form of a tube of circumvolutions; this tube is cut into short lengths, of only two circumvolutions, each of which forms one head; these are made red-hot in an iron pan, over a furnace, to soften them, that they may not spring under the hammer in fixing them on. These annealed heads are distributed to children, who sit with little anvils and hammers, the latter being worked by means of the feet upon treadles. Taking up a pin, they thrust its blunt end amongst a quantity of the head-spinnings; and, catching up one, they apply it immediately to the anvil, and, by means of two or three blows of the hammer, compress the head firmly upon the end of the wire, with remarkable dexterity. The several motions of the little operator succeed each other so rapidly that it requires the closest observation of the process, many times repeated, to enable a stranger to perceive how it is performed. The pins have now to be whitened, which is effected by putting them in a solution of tin in the tartaric acid. Here they remain until they have acquired an extremely thin coat of the tin, which presents, when withdrawn from the bath, but a dull appearance: the pins are therefore thrown with some bran into a barrel, which, being in revolution upon its axis, the bran thus rubs the pins quite bright; they are then taken out, and the bran separated from them by a winnowing machine. Machines have, however, been recently constructed, in which a coil of wire is converted into pins without any manual intervention, or any extraneous assistance whatever.

**PINCHBECK, or PRINCE'S METAL.** An alloy of copper, much resembling gold in colour. It consists of one part zinc to five or six parts of copper.

**PINION**, in *Mechanics*, a small-toothed wheel, which drives, or is driven by, a larger.

**PINNACE.** A small vessel, navigated with oars and sails, and having generally two masts, which are rigged like those of a schooner. One of the boats belonging to a man-of-war, for carrying the officers to and from the shore, is called the pinnace.

**PIPE.** A cask containing from 110 to 140 gallons of wine; the Madeira pipes containing about 110, and the Port and Lisbon from 138 to 140 gallons.

**PIPES**, for the conveyance of water and other liquids, are made of lead, iron, stone, pottery, wood, Indian-rubber, &c. Of iron there are two sorts,—wrought and cast.

*Wrought-iron pipes* are made out of plates of the required thickness, length, and breadth; so that when coiled into a circular form, the edges may lap over each other. To make sound, good work of this kind requires great address and

rapidity of execution in the welding operation; so that the ordinary smith rarely attempts it, preferring to purchase the article, or get it made by the regular tube-makers. The manufacture of wrought-iron tubes has lately, with considerable success, been effected by machinery, under a patent granted to Mr. Whitehouse (for Mr. Russel), of Wednesbury. The sides of the metal being bent up with swages, so as to bring the edges nearly together, he introduces the tubes so prepared into a furnace, and, when brought to a welding heat, to the operation of a small tilt-hammer: the face of the hammer, as well as that of the anvil, have semi-cylindrical grooves, corresponding with the size and shape of the tubes under manufacture; and between these the tube is gradually passed along, receiving in its progress a rapid succession of blows from the hammer. When the welding is thus completed, the tubes are in a rough state; they are therefore again heated in the furnace, and passed between large round rollers, which give to the tubes a smooth exterior surface; as they emerge from the pressure thus given, they come in contact with a fixed round rod, of the proper size of the bore of the tubes or pipes, over which they are forced by the rollers; and thus the interior as well as the exterior are brought to a smooth and true cylindrical surface.

*Cast-iron pipes*, of which immense quantities are used for the conveyance of gas, water, and other fluids, are made in the following manner. The mould for casting is thus prepared: strong cast-iron flanged cylinders, about three feet long, and having an internal diameter greater than the outside of the intended pipe. These cylinders divide longitudinally into halves, which are secured together by iron cramps; in this state one of them is placed upright upon a firm foundation, underneath the jib of a crane, to which is suspended a smooth cylindrical mandril; this mandril is then lowered perpendicularly into the centre of the cylindrical mould until it rests in a hole in the stand at the bottom, and leaves around the mandril a void space of equal dimensions, in which position it is secured by wedging pieces at the top. Sand duly prepared and moistened is then put into the void space by degrees, until it is filled, ramming it down at intervals, to render it equally solid throughout. The smooth mandril is then carefully drawn out by the crane, and the sand-charged cylinder is removed to the drying stove. Other cylinders are similarly charged, and dried in the stove. To make the core, the moulder takes a quadrangular bar of iron, about a foot longer than the intended pipe, wraps it along with a hay-band, and inserts it centrically into a pipe smooth in the inside, of the length, and of the same internal diameter as the required pipe; a mixture of sand loom, hair, &c. is now rammed between the cylinder, and is thus forced amongst the fibrous matter around the bar, to which it firmly adheres when drawn out of the smooth-sided cylinder; the core thus produced being dried in the stove, is ready for the casting. As the length of cast-iron pipes for water is usually nine feet, three of the before-mentioned cylindrical sand-boxes are put into requisition for the purpose; they are placed one upon the other upright in a pit, and connected together by cotters through their flanges. The sand and loam core before mentioned, is now carefully lowered from a jib into the centre of the combined sand-boxes, which is insured by a projecting piece of the iron bar entering a socket at the bottom, and the upper end is secured by a collar of clay. The space now left between the core and the cylinder of sand is now filled with liquid metal through an orifice in the clay at top, by means of a ladle, charged from the tap hole of the furnace, which is carried and poured into the mould by the casters, if not too heavy; but if so, this carriage is assisted by a truck or drag, and the ladle or pot discharged by the aid of pulley tackle. When the mould is cooled, it is hoisted by the crane altogether from the pit; the outer cases are taken off, the iron rod withdrawn, and the pipe being cleared from the sand inside and out, is ready for clearing, examination, and use. In the casting of very large cylinders, a similar process is adopted, except that the metal is allowed to flow directly from the furnace, along a trench into the mould.

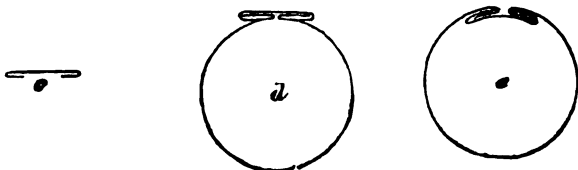
*Hancock's patent Pipes*.—A patent was taken out in 1826 by Mr. Walter Hancock, of Stratford, in Essex, for the manufacture of water or other pipes,

that should be as durable, but less expensive, than the cast-iron pipes we have been just describing; and as the manufacture of these may be advantageously conducted in situations where the products of a foundry cannot easily be procured, we annex the ingenious process of the patentee.

Sheets or strips of iron or copper are selected of the appropriate lengths, breadths, and thicknesses, for making the proposed pipes. In making a cylindrical pipe, the sheet must be of greater width than the circumference required, and of a true rectangular figure. Each of the two opposite edges are then to be doubled or folded back, as shown by the annexed figure *a*. The sheet is



then to be bent round by the ordinary means into a cylindrical form, and the edges turned back as shown in the annexed *Fig. b*. A slip of sheet iron, of the same thickness and length as the before-mentioned, with parallel sides, is then doubled back at the edges in the same manner as shown at *c*; this piece is then slid over the ends of *b*, so that the edges of both shall mutually envelope and brace each other, in the manner exhibited in the following *Fig. d*; the joints thus made are then brought into close contact by hammering. This method of joining the tubes may with equal facility be effected on the inside, if in turning the sheet up into the cylindrical shape it be bent the reverse way, as shown in *Fig. e*. The projecting part of the joint being inside, is preferable in many cases. The tube, as now described, the patentee calls his *inner* tube, to distinguish it from the



exterior covering it afterwards receives, to increase its strength and durability. This is effected by winding round the inner tubes iron hoops, or narrow strips of metal, rivetted end to end in a spiral direction, with the coils in close contact generally, but sometimes a little apart, to give them elasticity in bending. The operation is performed by fixing the tube upon a wooden roller, of a diameter nearly corresponding with the internal diameter of the said tube, and the roller is mounted horizontally upon an iron axle in a fixed frame, with a handle for turning it round at one or both ends. One of the ends of the hoop iron is then made fast to the end of the tube by a rivet, and being held in an oblique position with the axis of the roller, the latter is turned round, while sufficient tension is given to the hoop iron to make it lie close and tight to the tube during the coiling operation; after which it is fastened to the other end of the tube by another rivet. A hoop or ring is now put on *hot*, to each end of the tube at right angles with the axis, for the greater security of the previous binding; these end hoops, as they cool, contract in their circumference, and consequently fix themselves, and bind all the parts of the tube firmly together.

The tubes are next to be immersed in liquid cement, contained in a vessel of suitable capacity to receive them; the cement is thus made to enter and fill up every fissure or interstice between the several parts of the tubes. The cement is composed of the following ingredients and proportions, mixed and melted together: viz. 2 lbs. bees' wax, 2½ lbs. linseed oil, 12 lbs. common white resin, 18 lbs. pitch, 1 lb. tallow, and 16 lbs. of plaster of Paris, or Roman cement, or

quicklime in powder; and when it is desired to give a greater degree of elasticity and toughness to the cement, 2 lbs. of Indian rubber, previously dissolved in five quarts of oil of turpentine, are to be added.

To protect the outside of the pipes from rust, one or more layers of canvas, saturated with the cement, are to be wrapped round it. In lieu of this, sometimes the patentees put a tube of sheet iron for the external covering, and fill up the interstices between with cement.

In order to connect such pipes together, a tube, similar to those already described, is prepared, of a length somewhat more than its diameter, which should be about three quarters of an inch greater than the diameter of the tubes to be connected; the latter being placed end to end, with the piece of connecting tube extending equally over each, and the annular space between the tubes are filled in with cement. To prevent the cement from getting in between the two opposed ends of the tubes, they are previously brought into contact, and covered at the point of junction, with a pley or two of oakum. At each end of the connecting tube is fixed a wooden ring, and the annulus thus rendered uniform is filled with the cement, in a hot and liquid state, by an iron syringe inserted in a hole made in the connecting tube. Instead of iron, the patentee makes use of wood sometimes for his inner tubes; these are composed of a number of pieces laid longitudinally side by side, and arranged in a circle. This tube is put upon a wooden roller, similar to the before-mentioned, and being turned round, it is covered spirally with iron hoops. For large sized tubes, wood is preferable, as being stiffer and stronger than those made of sheet iron of moderate thickness. The wooden tubes, bound in iron, are completed by similar processes to those described in the other kind.

Bagshaw's patent earthen pipes are thus made:—Cylindrical plugs of wood, of the same diameter as the bore of the intended pipe, and of the same length, are coated with a sufficient thickness of clay, or plastic earth, which has been duly prepared in the manner practised in the potteries. To perfect the exterior form of the pipe, an external mould is to be employed, consisting of two semi-cylindrical pieces, which are to be placed on each side of the intended pipe, when the edges are to be brought together by screwing them up, which will press out the superfluous clay from the mould; the exterior mould being next removed, the pipe will be found completely formed upon the plug: in this state it is to be dried; after which the plug may be easily withdrawn, and the pipes finished, by baking them in an oven. The pipes are to be connected together by inserting the smaller end of one into the larger end of another, and filling up the interstices between them with Roman or other soft fluid cement. Pipes produced in a similar manner, of which the material was a *cement or imitation of stone*, have likewise been brought into use.

Some years since Mr. Murdock took out a patent for the economical fabrication of *pipes of real stone*, the process combining the advantage of making solid cylinders at the same time. In forming a pipe or hollow cylinder of stone, instead of cutting out in useless scraps, or grinding to powder, the whole diameter of the bore, the patentee cuts out a core or solid cylinder, whose outside diameter is only about half an inch less than the inside diameter of the pipe. In like manner, when he intends to form a column or solid cylinder, or disc of stone, instead of breaking off, cutting, or chiseling away the superfluous parts of the stone, these parts are formed into a hollow cylinder, the core of which is the solid cylinder or disc required. Hence, if the stone is large enough to leave the outside parts of a proper thickness, these parts may be used as a pipe, and the core may either be used as a solid cylinder or column; or, by a farther operation, it may be converted into a pipe, and the cylinder cut out of it may again be converted into another pipe, which process may be continued until the core cut out is too small to be useful. The following is the mode adopted by the patentee of accomplishing it:—he fixes the block of stone to be perforated in an upright position, and in the centre of the top of the block of stone, a step to receive the toe of a vertical spindle, which derives its motion from a pulley turning in plummer-blocks in a fixed frame above; this axis is considerably longer than the pipe or column to be formed, having the faculty

of sliding vertically through the aforesaid horizontal pulley, over which it is suspended by a rope that passes round a vertical pulley, and thence is connected to a winch to wind up the axis at pleasure. The saw employed is at the edge of a hollow cylinder (on the same plan as that described by us for trepanning, under the article ANNULAR SAW), and this hollow cylinder is turned by the spindle through the medium of cross-arms, through which the axis slides; and, in order to give the requisite force to the annular saw, the top of the tube to which it is fixed is loaded, provided its own weight be insufficient: the motion given to the saw, though circular, is reciprocating. To effect this, a rope passes round the pulley at the upper part of the axis, and the two ends of the rope are conducted in opposite directions over two vertical pulleys, over which the two ends of the rope respectively fall, where they are each furnished with a cross-handle; one workman takes hold of one handle, and another workman the other, and pulling alternately the pulley at the top of the axis, together with the annular saw, is made to reciprocate circularly, cutting an annular groove in the block of stone. A barrel of sand and water is made to deliver these essential auxiliaries to the saw in the following manner:—it is directed to the upper end of the axis above the tube, which it enters, and runs down into the annular groove under the edge of the saw, whence it flows upward by the pressure of the continued descending current on the opposite side, and thus carries off the sludge clear of the saw. Stone tubes of this kind were employed by the Manchester Water Works Company.

Elastic tubes of Indian rubber are extensively used for the transmission of gas and corrosive liquids; and they are admirably manufactured by Mr. Thomas Hancock, of Goswell-street Road. Mr. Thomas Skidmore, an American gentleman, whose process is a good one, is as follows:—Take a cylindrical rod of iron of the desired length, round this closely coil annealed wire in the manner of a spiral spring, care being taken that the edges of the coiled wire shall touch each other, but shall, at the same time, not be so firmly wound as to prevent its slipping off the rod: then cover the wire with tape spirally from end to end, and upon it lay strips of Indian rubber, wound in a similar manner, with their fresh cut and clean edges lapping upon each other. Then bind these down tightly with another coil of tape: after this withdraw the rod, and boil the tube in water for an hour or two; when cool, remove the wire and tapes, and an Indian rubber tube will be produced, which, though rough, will be perfectly sound if the process has been properly conducted.

The method of making *lead pipes* has been described under the article LEAD; but we will take the opportunity of mentioning in this place, that it appears, by some recent experiments made by Mr. Jardine, of the Water Company's Works at Edinburgh, that a lead pipe of  $1\frac{1}{4}$  inch bore, and the fifth of an inch in thickness, was found capable of sustaining a power equal to that of a column of water 1000 feet high, which is equal to 30 atmospheres, or 420 pounds per square inch of internal surface. With a pressure of 1200 feet it began to swell, and at with 1400 feet it burst. In another experiment, a pipe two inches in diameter, and one-fifth of an inch thick, sustained 800, but burst with 1000 feet pressure.

*Wooden pipes* for the conveyance of water, are bored by means of large iron augers, worked by one or two men, who commence with a small bore, and increase it as the work proceeds, by changing the auger to a larger size, which are sometimes extended to eight or nine inches in diameter. The tree in the process of boring, is laid horizontally upon tressels constructed to support and hold it firmly, and the augers are similarly supported and guided, so as to pass centrally through the tree. The manual operation is of course slow, and extremely laborious: machinery, worked by steam, or other power, has therefore been introduced to execute the work. The piece of timber, or tree, is held down upon a frame by chains passing over it, and round two windlasses. The frame and tree, thus bound together, run upon small wheels traversing two long beams, called ground-sills, placed on each side of a pit, dug to receive the chips made by the borers. At one end they are connected by a cross-beam, bolted upon them; this supports the bearing for a shaft, the extremity of which, beyond the

bearing, is perforated at the end of a square hole to receive the end of the borer. The timber and carriage are made to advance towards the borer by means of ropes; one rope being made to wind up, while the other gives out and draws the carriage and piece of timber backwards and forwards according as the wheel is turned. The weight of the borer is supported by a wheel turning between uprights fixed on a block, the end of which rests upon the ground-sills: it is moved forward by means of two iron bars, pinned to the front cross-bar of the carriage. The distance between the wheel and the carriage may be varied by altering the iron bars and pins, so as to bring the wheel always as near as convenient to the end of the tree. The shaft may be turned by any first mover. When the borer is put in motion by turning the wheel, he draws the tree up to the borer that pierces it; when a few inches are bored, he draws the tree back by reversing the motion of the wheel, in order that the borer may throw out its chips; he then returns the tree, and continues the process until the work is finished: the borer, in this case, be its size what it may, is of the same shape as that of a common auger. We would suggest the employment of spiral augers instead of the common, as the former would deliver the chips as it proceeded, and not require withdrawal until the perforation was completed.

Some years ago Mr. Howel, of Oswestry, invented a machine for making concentric wooden pipes out of one piece of timber, the mechanism of which was on the same principle as that we have described under Mr. Murdock's patent for sawing out stone pipes, who, it appears, derived the principle of operating from Mr. Howel, and modified it so as to adapt it to the cutting of stone.

*Tobacco-pipes.*—The clay of which these are made is obtained from Purbeck, in Dorsetshire, and at Teignmouth, in Devonshire, in large lumps, which are purified by dissolving in water in large pits, where the solution is well stirred up, by which the stones and coarse matter are deposited; the clayey solution is then poured off into another, where it subsides and deposits the clay. The water, when clear, is drawn off, and the clay at the bottom is left sufficiently dry for use. Thus prepared, the clay is spread on a board, and beaten with an iron bar to temper and mix it; then it is divided into pieces of the proper sizes to form a tobacco-pipe; each of these pieces is rolled under the hand into a long roll, with a bulb at one end to form the bowl; and in this state they are laid up in parcels for a day or two, until they become sufficiently dry for pressing, which is the next process, and is conducted in the following manner:—The roll of clay is put between two iron moulds, each of which is impressed with the figure of one-half of the pipe; before these are brought together a piece of wire of the size of the bore is inserted midway between them; they are then forced together in a press by means of a screw upon a bench. A lever is next depressed, by which a tool enters the bulb at the end, and compresses it into the form of a bowl; and the wire in the pipe is afterwards thrust backwards and forwards to carry the tube perfectly through into the bowl. The press is now opened by turning back the screw, and the mould taken out. A knife is next thrust into a cleft of the mould left for the purpose, to cut the end of the bowl smooth and flat; the wire is carefully withdrawn, and the pipe taken out of the mould. The pipes, when so far completed, are laid by two or three days, properly arranged, to let the air have access to all their parts, till they become stiff, when they are dressed with scrapers to take off the impressions of the joints of the moulds; they are afterwards smoothed and polished with a piece of hard wood.

The next process is that of baking or burning; and this is performed in a furnace of a peculiar construction. It is built within a cylinder of brickwork, having a dome at top, and a chimney rising from it to a considerable height, to promote the draught. Within this is a lining of fire-brick, having a fireplace at the bottom of it. The pot which contains the pipes is formed of broken pieces of pipes cemented together by fresh clay, and hardened by burning; it has a number of vertical flues surrounding it, conducting the flame from the fire-grate up to the dome, and through a hole in the dome into the chimney

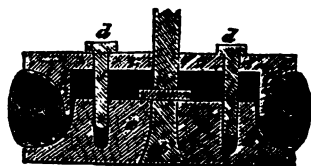


Within the pot several projecting rings are made; and upon these the bowls of the pipes are supported, the ends resting upon circular pieces of pottery, which stand on small loose pillars, rising up in the centre. By this arrangement a small pot or crucible can be made to contain fifty gross of pipes without the risk of damaging any of them. The pipes are put into the pot at one side, when the crucible is open; but when filled, this orifice is made up with broken pipes and fresh clay. At first the fire is but gentle, but it is increased by degrees to the proper temperature, and so continued for seven or eight hours, when it is damped, and suffered to cool gradually; and when cold, the pipes are taken out ready for sale.

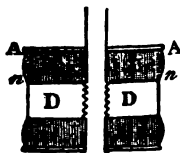
**PISTON.** That part in a steam engine on which the elastic force of the steam exerting itself puts it into motion; and which, through the medium of the piston rod connected thereto, actuates the entire machine. The term piston is likewise sometimes employed to designate what is more generally termed the "bucket" of a pump. There is no part of the steam engine in which correct principles of construction and accurate workmanship are so essential. If the sides of the piston which rub against the cylinder or steam-way do not touch in every part, the steam escapes, power is lost, and fuel is wasted. If the piston rubs hard in one place, and softly in another, the cylinder becomes unequally worn, and its utility impaired or destroyed. To obviate these difficulties, therefore, the rubbing surfaces of a piston should not only be made as uniformly as possible, but also elastic, in order that it may expand and fill up all inequalities of surface with a gentle pressure. The usual mode of effecting this object is

represented in the subjoined section of a common piston for a low pressure engine; *a* is the lower face of the piston made of metal, to which is fixed the piston rod *b*, that passes through the top plate *c*, which is made fast to the lower by screws *d d*; at *ee* is the packing (as it is termed,) made of hemp, saturated with tallow, which is wound and bound round the annular cavity made between the plates *a* and *c*; this elastic packing, as it wears away by friction against the cylinder, is occasionally screwed up, by turning the screws *d d*, which forces it out against the sides of the cylinder; and when entirely reduced, it is renewed by repacking with fresh materials. From want of due care and skill in this kind of packing, a great loss of power in an engine is often sustained, either by the steam passing the piston, or by its being squeezed so tight as to cause great friction, and soon wear itself out. If the steam of an engine be weak, and the packing of the piston press tightly against the cylinder, the whole, or nearly the whole of the power may be expended in giving it motion, especially in cylinders of small diameter. On the contrary, if the packing presses very weakly against the cylinder, and the steam be very strong, the steam will push the packing away, and pass to the other side of the piston; and it should be borne in mind, that when this happens, it is not only the loss of the steam, but the reaction which it exerts on the other side, neutralizing an amount of force equal to its own volume. For these reasons, it becomes obvious that pistons should possess another property, that of being tight in proportion to the force of the steam which presses upon them. Several plans have been proposed to construct pistons on that principle, amongst which are the following, proposed by a correspondent in a periodical journal in 1823, which perhaps deserve notice, as furnishing useful hints to the practical man.

In the annexed *Fig. 1*, *AA* is a metal plate sliding upon the piston rod; *DD* is the solid part of the piston, connected with the plate by a band *nn*; the space *CC* is to be filled with oil or other oleaginous fluid. By this arrangement it will be evident that the greater the force of the steam, or other pressure, upon the surfaces



*Fig. 1.*



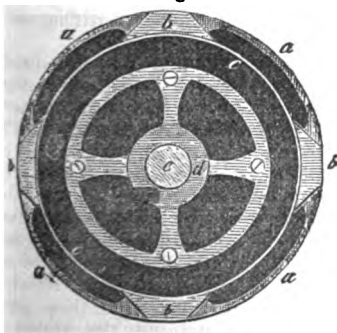
of the plates, the more closely will the packing be pressed against the sides of the cylinder.

The annexed *Fig. 2* is a variation from the last; the top and bottom plates are fixed, and the steam acts upon short bolts or plungers *b b*, which, by being pressed inwards, force out the packing at the sides. *Fig. 3* represents a mode of applying the principle to metallic pistons. *A A* is a metallic plate sliding on the piston rod, and made in the form marked by the dark line. At *B B* are metallic rings of a triangular form, divided and breaking joint: *D D* is the solid part. The pressure of the steam will cause the plates to descend, which, pressing upon the inclined planes of the rings, of course causes them to expand, and adhere to the sides of the cylinder; a small space is left between the solid part and the plates, to allow for the descent of the latter, but in no way so great as represented: the figures being only designed by the inventor to show the principle, and not the details of construction. Pistons packed with hemp and tallow continued in use, with very little variation, from the time of Captain Savery to that of Dr. Cartwright, a period of ninety-nine years. That scientific clergyman had, however, the honour of first introducing, in an ingenious engine of his own construction, an expanding or elastic piston made entirely of metal,—an invention of indispensable utility in all engines working at high pressure.

As this piston has been considerably modified by various engineers, which we shall have to notice hereafter, we shall here state briefly that it consisted of two rings of brass, of the full size of the cylinder; these rings were each cut into three or more segments, and laid one over the other, so as to break the continuity of the vertical joints between the segments; concentric with those segments were a similar arrangement of segments inside the others, which were intended to stop the steam from passing horizontally; in the cavity between all the segments were placed feather springs, designed to press the segments outward to fill up the cylinder as either that or the piston wore. These pistons, however, proved very defective; for as the exterior segments wore, and conformed to a larger circle, the inner segments, which had no wear, were no longer concentric with those outside of them, and crevices were thus opened, through which the steam escaped past the piston.

Amongst those persons who directed their attention to the improvement of this important part of the engine, Mr. John Barton was the most successful. In the annexed engravings, *Fig. 1* represents a plan of the piston, with the top

*Fig. 1.*



*Fig. 2.*

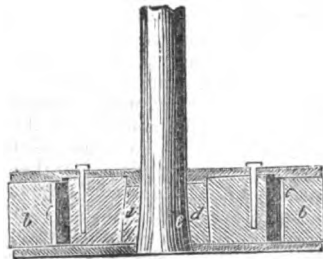
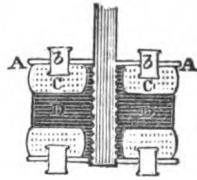
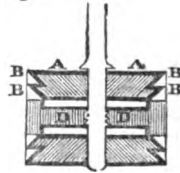


plate removed, and *Fig. 2* a vertical section of the same, taken on the line *b c d b* on the plan. *a a a a* are four metal segments; *b b b b* four right-angled wedges

*Fig. 2.*



*Fig. 3.*



interposed between the segments, their points forming a portion of the periphery; *c c c c* is a thin steel spring, formed into a single broad hoop, and pressed into the undulated form represented, by which it is found to act with uniform energy upon the wedges, until they and the segments become so much worn in the course of time, that the steel spring recovers itself into its original circular figure; *d* is the frame-work cast in one piece with the lower plate of the piston; *e* is the piston rod; the dark spaces shown on the plan within the circular frame *d* are cavities to lessen the weight of metal; the other dark spaces are cavities to allow of the free action of the circular spring.

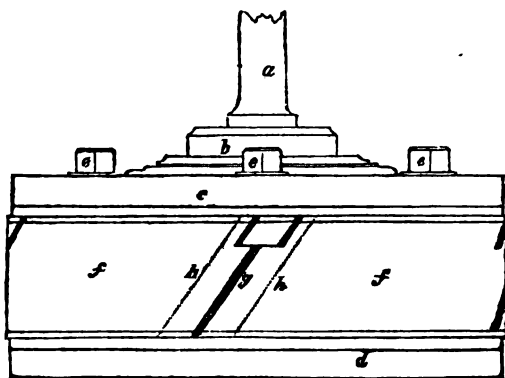
To prevent the segments from falling out of their places whilst the piston is being taken out, or put into the cylinder, the periphery of it is grooved near to its upper and lower edge, in which are sunk two slight spring hoops, cleft across into forked joints, which close together simply by their elasticity. To lubricate the piston, there is a third groove, made midway between the two former for the reception of the oil; these parts are not introduced into the figures. The action is as follows: as the piston and cylinder wear away by the friction, the circular spring *c* presses out the wedges *b*, and these project the segments against the cylinder; and as the segments become reduced, the wedges fill up the increasing opening between them.

An objection has been raised against this piston, that as the wedges must move through a greater space than the segments, in order to press the latter into the circumferential line, the wedges must in consequence rub twice as much against the cylinder, and consequently score it. This objection we believe to be unfounded; and as far as our experience and observation have extended, we have found the wear very uniform. Mr. Barton, perhaps, softens the segments, or makes them of an alloy, which is more easily abraded than the segments; sometimes (we have been informed,) he obviates the supposed tendency of scoring, by cutting out a portion of the end of the wedges, so that they do not bear upon their whole depth or thickness against the cylinder, consequently they will abrade twice as fast as the segments, supposing them to be equally hard. A great variety of metallic pistons have been made of late years, but we know of none that have so fully answered the purpose as the recently patented improvement by Mr. John M'Dowall, of Johnston, near Paisley, who has a manufactory of them at Manchester, where, we understand, great numbers are advantageously working in the engines of the factories. We have seen them in other parts of the kingdom, and can attest their superior excellence.

In the specification of his patent, Mr. M'Dowall states, that his experience in the working of cast-iron pistons led him to observe that the surfaces of the metal between the segments and the plates against which they slide rapidly corrode, and become converted into a substance resembling plumbago, by which the effectiveness of the piston is of course seriously impaired. As a remedy for this defect in cast-iron pistons, he lines or covers the aforesaid surfaces with plates of brass or gun metal, which he connects by screwing or pinning to the cast-iron, and thus acquires the durability of the gun metal at a trifling additional expense above cast-iron.

Another important improvement which Mr. M'Dowall has introduced, consists in a modified construction of the segments, and in the steam stops or slides by which they are pressed outwards. In the figure on the next page is exhibited an external elevation of one of these cast-iron pistons: *a* is the piston rod which passes through a solid central block, the upper part of which is seen at *b*, and through the top plate *c*, and bottom plate *d*, the latter being made fast to the bottom of the central block through the medium of the piston rod; the top plate *c*, for the convenience of removal at pleasure, is fastened to the central block *b*, by means of screws *e e e*. Between the top and bottom plates, and around the periphery of the central block, are fitted an expanding ring of segments, two of which are seen at *f f*; these segments instead of being divided by perpendicular cuts, as usual, have these parts inclined, as seen at *g*, which thus overlap each other, and cause the cylinder to be equally worn, (which would not be the case were the apertures between the divisions vertical.) The inclined crevices through which the steam might pass

is stopped by movable sliding pieces, which are made to press continually against the segments by the agency of springs, in the same manner as the wedges are acted upon by the springs in Barton's piston, previously described. One of these sliding pieces is seen at *g*, the projecting part of it being of a rhomboidal



figure, that fills up corresponding notches made in the corners of the segments, and those parts which come in contact, and are represented by a single line, are faced and ground to each other, to prevent the upward or downward passage of the steam; and to stop it laterally, the slides are ground to fit the backs of the segments to which they are connected, by dove-tailed grooves, represented by the two parallel dotted lines *h h*. The double lines at *i*, both above and below the segments, indicate the brass linings before mentioned. Mr. M'Dowall's patent includes the application of the same improvements, namely, the sliding steam stops, and the brass linings to the air-pump buckets of steam engines, described under the article VALVE, to which his principal improvement in this appendage relates.

**PITCH.** A resinous substance, obtained by the inspissation of tar. There are two methods of obtaining it; one by simply boiling the tar in large iron pots, or by setting it on fire and letting it burn until it obtains such a consistence as, by dipping a stick in it, and exposing it to the air, it readily solidifies. Two barrels of the best tar, or two and a half barrels of green tar, are thus convertible into one barrel of good pitch. The foregoing has reference only to tar obtained from the pine-tree and other vegetable matters; but a large quantity of tar and pitch are obtained in this country from coal. On the banks of the Grand Junction Canal, in the vicinity of the large iron and coal works, there were established some years ago several "tar-works," to which the iron masters sent their raw coal, gratis, and received, in return, the cokes produced by such coal; the proprietors of the tar-works being contented with the compensation afforded by the *smoke* alone: the following is the process of obtaining it:—A range of eighteen or twenty stoves is erected, and supplied with coal kept burning at the bottom; the smoke is conducted by proper horizontal tunnels into a capacious and close funnel, of one hundred or more yards in length: this funnel is built of brick, supported by brick arches, and covered on the top by a shallow pond of water, which pond is supplied with water, when wanted, by a steam engine belonging to the coal or iron works. The coldness of the water gradually condenses the smoke, causing the tar to fall on the floor of the funnel, whence it is conveyed by pipes into a receiver; from the latter it is pumped into a boiler, and evaporated to the required consistence, or otherwise inspissated into pitch: when the latter is the case, the volatile particles which arise during the inspissation are again condensed into an oil used as a varnish. In this process the

smoke is decomposed, nothing arising from the work but a white vapour from some small funnels (kept open to give draft to the fires), and a small evaporation of water from the pond, occasioned by the heat of the smoke underneath it. The process requires but little attendance, the principal labour being that of supplying the fuel. In a tar-work, where twenty tons of coal are consumed per day, three labourers and a foreman do the whole business; and the quantity of tar produced will be about 28 barrels of  $2\frac{1}{2}$  cwt. each; or 21 barrels of pitch of the same weight, in six days. Some coals are, however, so bituminous as to yield one-eighth of their weight of tar.

**PIVOT.** A short shaft on which a body turns or revolves.

**PLAN.** A representation of something according to the proportion of its parts, made on a flat surface, as on paper, pasteboard, &c.; such are maps, charts, &c. By the term plan, however, a draughtsman understands it to be either a ground plan of a building, machine, &c., or the arrangement and exact proportions of a horizontal section made in any part of the same.

**PLANE,** in Geometry and Mechanics, a perfectly flat surface in whatever position, as horizontal plane, vertical plane, inclined plane. If a sphere be cut by a plane, the section will be a circle. If a prism or cylinder be cut by a plane, either through or parallel to its axis, the section will be a parallelogram; and if either of these be cut by a plane parallel to its base, the section will be similar to that base. Also, if a cylinder be cut obliquely by a plane passing through its opposite sides, the section will be an oval or ellipse. If a pyramid or cone be cut by a plane passing through the axis, the section will be a triangle; but if they be cut parallel to the base, the section will be similar to the base. If a cone be cut by a plane parallel to its side, the section will be a parabola; if it be cut obliquely, so that the plane does not pass through either the base or the opposite cone, the section is an ellipse; if it be cut by a plane which passes through the base and the opposite cone, but does not pass through the vertex, the section is a hyperbola; and, lastly, if it be cut by a plane, either parallel to the base, or in sub-contrary position to it, the section is a circle.

**PLANE.** An instrument employed for shaving wood and other substances to a true plane or smooth surface, of which there are a great variety; they are usually divided into two principal kinds, namely, bench-planes and moulding-planes; of the former, the principal are the long, jack, trying, and smoothing-planes: each of these is again distinguished into double or single iron, according as the cutting part is formed. The single iron is an iron blade, the lower end of which is steel; and the cutting-edge is formed by grinding it to a single acute angle, as represented by the piece marked *d* in the following cut; its operation is partly of a cutting and partly of a scraping nature. In planing some kinds of wood great inconvenience was found from this form by its frequently tearing up the surface instead of smoothing it; a partial remedy for this defect was, in consequence, introduced about thirty years ago, by which another plane-iron, called a "top-iron," represented at *e*, was added to the under one by means of a strong connecting screw, which causes the edge to press closely upon the lower one. The cutting-edge of *d*, which projects a little beyond *e*, is, therefore, the same as before; but it is prevented from entering so deeply into the wood, or rather, the shaving which has been abraded from the wood receives a new direction by the abrupt interposition of the top iron *e*, and prevents the surface of the wood from being torn. This improvement is so decided as to cause almost an entire disuse of single iron planes. The remedy, however, is incomplete, especially for the planing of very hard woods; for which purpose, in particular, Mr Williamson, of Kennington, has found it advantageous to modify the single iron *d*, by making it of greater thickness, and giving it a bevel on both the top and bottom sides, at an angle similar to that shown on the under side of *d*. By this altered form of edge, it will be evident that it partakes more of the *scraping* action; yet it is found to obviate more effectually the defects of former constructions. The edge is stronger and more durable; it gives a beautiful smooth surface almost without the aid of the scraper; and, from its utility to workmen,



entitles the inventor to the reward (of ten guineas) given to him for it by the Society of Arts. It is peculiarly valuable in planing hard woods across the grain; as in preparing box for the use of engravers.

**PLANE-CHART**, in Navigation, a sea-chart constructed on the supposition of the earth and sea being an extended plane surface. Such charts have, consequently, the meridians represented as right lines to each other.

**PLANE-SAILING**. The art of performing the several reckonings necessary for conducting a ship on the ocean on the principles of the plane-chart.

**PLANE-TABLE**. An instrument by which the draught or plan of an estate, &c. may be taken on the spot, while the survey or measuring is going on. It consists of a perfectly flat rectangular board, sufficiently large for the purpose, the centre of which moves freely on a ball and socket attached to the top of three legs, on which the instrument stands; by this means, when the legs are fixed in the ground, the table may be inclined or moved round in any proposed direction. For the purpose of fixing a sheet of paper on the table, there is a frame of wood, which fits exactly round its edges; one side of this frame is graduated into equal parts, and the other side into degrees from the centre of the table; by which means this instrument is made to answer the purpose of a theodolite. To the side of the table is screwed a magnetic needle and compass, to take directions and bearings; and, lastly, there is a brass two foot scale, furnished with two open sights, or else a small telescope, serving as an index. The use of the plane-table is as follows:—Having moistened a sheet of writing or drawing paper, spread it flat on the table, and secure it in this position by pressing down the frame on its edges. When this paper is dry it will be perfectly smooth, and ready to have drawn on it the plan of the proposed scene. We then begin by setting up the table at any part of the ground that is judged most proper; and having done this, a point is made in some convenient part of the paper to represent the spot where the instrument stands; we are then to fix in that point of the paper, on a leg of the compasses, or a fine steel pin, and apply it to the fiducial edge of the index, moving it round the table close to the pin till some desired point or remarkable object, such as the corner of a field, a tree, a picket, &c. be seen through the sights; from the station point an obscure line is then to be drawn along the fiducial edge of the index. We then turn the index to another object, and draw a line on the paper towards it. The same process is repeated till as many objects are set as may be deemed necessary for the purpose. We then measure from our station to each of these objects, taking the necessary offsets to corners and bendings in the edges, &c., laying down the measured distances, taken from a proper scale, upon the respective lines on the paper. The table is then to be removed to any one of the objects to which the measuring was made, as a second station. Here it must be fixed in its original position, turning it about the centre for that purpose, both till the magnetic needle points to the same degree of the compass as at first, and also by laying the fiducial edge of the index along the line between the two stations, and turning the table till the former station can be seen through the sights on the index: it is to be fixed in that position. From this new station repeat the former operations, setting several objects by the edge of the index, and measuring and laying off the distances. In this manner we proceed from one station to another, measuring such lines only as are indispensable, and determining as many as possible by intersecting lines of direction, drawn from different stations. If, before the survey be completed, the paper be full of lines, measurements, &c., recourse must be had to another sheet of paper. Draw a line in any manner through the farthest point of the last station line to which the work can be conveniently laid down; then remove the sheet from the table, and fix a perfectly clean sheet in its place, drawing upon it, in a part the most convenient for the rest of the work, a line to represent that drawn at the end of the work on the former sheet. Cut or fold the old sheet by this line, and apply the edge so that it may exactly coincide with the corresponding line on the new sheet. While they lie together in this position, produce the last station line of the old sheet upon the new one,

and place upon it the remainder of the measurement of that line, beginning where the work ended on the old. In this manner the process may be continued from one sheet to another, till the proposed survey is complete. When the survey is finished, the sheets are all to be fastened together, taking care that the lines in one sheet accurately meet the corresponding lines in another throughout.

**PLANETARIUM.** An astronomical machine of the same nature as the orrery, designed to exhibit the orbits, motions, and phenomena of the planets in the solar system. In a machine of this kind, which was constructed by Huggens, and is preserved in the University of Leyden, the revolution of the primary planets about the sun, and that of the moon round the earth, are performed in the exact time that they are actually performed in nature. The orbits of the moon and planets are here represented with their true proportions, eccentricities, positions, and declinations from the ecliptic; and by this machine, as by a perpetual ephemeris, the situations, conjunctions, oppositions, &c. of the planets for any time may be accurately determined. Dr. Desaguliers constructed a very complete planetarium, which he has described in his *Course of Experimental Philosophy*, published in 1734; but the most stupendous, superb, and elaborate planetarium ever constructed, was that which was publicly shown in London in 1791, and afterwards purchased by government to be sent out with Lord Macartney, in 1793, as a present to the emperor of "the *Celestial* empire." It exhibits all the bodies, both primary and secondary, of the solar system, with their orbits in their due proportions and positions, and all performing their annual and diurnal motions exactly as in nature, exhibiting, at all times, the true and real motions, positions, aspects, phenomena, and even the inequalities of their motions in elliptical orbits. As engravings of planetariums have, however, been exhibited in all the Cyclopædias and works of mechanical science, and as every mechanic well understands that their motions are regulated by a numerous train of wheels, which it would be extremely tedious to detail, precisely in the same manner as in horological machines (the hands or indexes of which, instead of bearing planets at their extremities point out the time), we shall content ourselves with referring the reader to the article *ASTRONOMY* in the *Oxford Encyclopædia*, for a very full and interesting account, illustrated by engravings, of several admirable machines of this kind.

**PLANING MACHINES.** For the planing of wood and metal on the large scale, by power, extensive and varied mechanism has been employed; in the invention and furtherance of which the late Mr. Bramah largely contributed. Under the article *FLOORING* we have described Mr. Muir's patent planing machinery.

**PLATINA.** One of the metals, and the heaviest body hitherto discovered in nature; its specific gravity being 21.54 when pure. It is obtained from an ore or metallic sand brought from South America, which contains, besides platina, four new metals, namely, palladium, iridium, osmium, and rhodium; also iron and chrome. Platina, combined with palladium and rhodium, is as hard as iron. It is not altered by exposure to the air, neither is it acted upon by the most concentrated simple acids, even when boiling or distilled from it. It is very malleable, though considerably harder than gold or silver, and it hardens much under the hammer. Its colour on the touch-stone is not distinguishable from that of silver. Pure platina requires a very strong heat to melt it; but when urged at a white heat, its parts will adhere together by hammering. This property, which is distinguished by the name of welding, is peculiar to platina and iron, which resemble each other, likewise, in their infusibility. Platina is obtained by dissolving the crude metallic particles in nitro-muriatic acid, precipitated by ammonia, and exposed to a very violent heat, by which the acid and alkali are expelled, and the metal is reduced in an agglutinated state, when it may be pressed together by a button-headed iron, be taken out of the furnace, forged, reheated, and forged again into a bar. Willis found that platina might sometimes be melted upon a bed of charcoal in a crucible; and M. Bousingault recently found that it might always be melted in a blast furnace, if the crucible

be lined inside with a mixture of clay and charcoal; the silicon, in his opinion, assisting in the reduction. Platina may be melted in quantities not exceeding two ounces at a time, by the oxy-hydrogen blow-pipe, and be kept in fusion for some time. Platina is much used for crucibles, evaporating dishes, and even alembics. Though it resists most of the acids, it is acted upon by caustic potash, and several of the neutral salts. The proper solder for it is gold. The concentration of sulphuric acid is now usually performed by platina stills, with leaden heads. Mr. Parkes has one of this kind, which holds only thirty-five gallons, yet cost 300 guineas.

**PLATING, or PLATED MANUFACTURE.** The art of covering other metals with silver. The method known by the name of French plating was usually applied to articles made of brass, after they were, in other respects, finished. After the goods were polished, and perfectly free from grease, &c., the part to be plated was heated to a temperature somewhat short of changing the colour of the metal. Leaf silver was now laid upon the part, and, while hot, was rubbed on with a hardened steel burnisher, perfectly dry and clean. By this means the silver adhered firmly to the brass, which, from the action of the burnisher, assumed a fine polish: these had much the appearance, in colour and lustre, of those of the present day; but they possessed but little permanence. This art is, therefore, scarcely now practised, from the introduction of the superior plan of plating upon ingots of copper, and forming the utensils out of the sheets and the wire made from the ingots.

The plated manufacture is divided into three departments, to each of which there is a distinct set of workmen. Those employed in making vessels such as are required to be raised by the hammer, are called braziers. The second sort are called candlestick-makers, being exclusively employed in making all the varieties of these articles. The third are called pierce workers; these were originally employed in making articles with ornamental open work, such as bread-baskets and trays of different kinds; but this species of work has now become obsolete, since the invention of plated wire. The articles in which pierce work had been made, are now formed by the varied intersections of wires, which give great lightness and elegance, with less waste, and more expedition.

Previously to describing the different branches of this art, we shall give the method of preparing the plated sheets and wire, of which all the different articles are made. The ingots on which the silver is laid are not pure copper, but an alloy, consisting of copper and brass; this gives it a degree of stiffness greater than that of copper, which renders it less liable to be deformed when in use. The metals are melted to a proper heat, in a peculiar furnace appropriated to that purpose. The heat of the metals, and the temperature of the mould when the metal is poured, are of great importance as far as regards the soundness of the ingot. When the metal is too cold, and its liquidity of course imperfect, the impurities cannot freely ascend, which causes imperfection in its substance. The same effect may take place from the moulds being cold; this, with the great conducting power of the metal mould, rapidly robs the metal of its caloric, and lessens its liquidity. The proper heat for the moulds is somewhat short of burning the fat with which they are greased on the interior surface. For the ordinary kind of work these ingots are generally cut in two in the middle, being more convenient for plating than longer pieces. The next process is to dress the face of the ingot for the purpose of receiving the silver on one or both sides, as it may be intended to be single or double plated. This is effected by filing, which is continued till the surface becomes entirely free from the least blemish: this is so important that the naked eye should not be depended upon; the surface of the copper should, therefore, be minutely examined by a magnifier before the silver is laid on. The thickness of the silver to be laid on the copper will be best known when it is understood that the silver, in single plated metal, or that plated on one side only, is from eight to ten pennyweights to the pound troy of copper; and, of course, double quantity when plated on both sides. When the plate of silver is cut to a little less than the size of the copper surface, made flat and scraped perfectly clean, the



copper surface being equally clean, they are laid together, and the silver plate is tied down with wire. A little of a saturated solution of borax is now insinuated under the edge of the silver plate on each side; this fuses at a low red heat, and prevents the oxygen of the atmosphere from affecting the surface of the copper, which would prevent the adherence of the silver. In this state the ingot is brought to the plating furnace; this furnace has a grate on a level with the bottom of the door. The fuel consists of coals. The ingot is laid upon the bare coals, and the door shut. When it has acquired nearly a proper degree of heat, the plater applies to the hole in the door to observe the proper point when the process is finished. When the silver and copper are uniting, the surface of the former begins to be rivetted, and this is the sign to remove the ingot from the fire as quick as possible. The ingot being now plated, is made perfectly clean, and is ready to be rolled. The first rollers employed for plated metal are of cast iron, similar in size and construction to those employed for sheet iron and sheet copper. The metal is rolled cold, and annealed from time to time. When it has gone through the rollers a certain number of times, it acquires a certain degree of hardness, so that the rollers have not much effect upon it; and if the rolling were continued, the metal would crack. To remedy this evil the metal is taken to a reverberatory furnace: it is laid upon a hearth of brick or fire-stone, and the flame of coal is made to pass over it; the heat, however, is not intense, since the metal is required to be slowly heated to a dull red. It may now be cooled in the quickest way possible, to save time, as quenching in water does not harden it, as is the case with steel. It now passes through the rollers as before, till it becomes hard, and then annealed and rolled again, till it is reduced something short of the size required. This being done, it is again annealed and passed through a pair of rollers faced with cast steel, and finely polished: this gives the surface great smoothness and truth. It is now annealed for the last time: after this the sheets are immersed in hot dilute sulphuric acid, then scoured with fine Calais sand, which fits them for the workmen to shape into different articles.

The first mode we shall describe is that of the braziers, or those who work with hammers. The nature of sheet metal is so similar to copper, that the working of it with the hammer, into various forms, will be very similar to that used by coppersmiths, with the difference of more exact and complete tools, and greater care on account of the value of the metal. Formerly all the different shaped vessels were made with the hammer, which made the price of labour very great. Now, all vessels of simple form, and not of large size, are formed in dies by means of the stamping hammer. This operation is now so general, that some manufacturers employ as many as six or eight of these engines. The dies are, or ought to be, made of cast steel; but it should be as hard as to weld to iron, so that the iron should not be much below the surface of the die. When the die is placed upon the anvil, and the metal cut into pieces of proper size, the next thing is to surround the top of the die with a paste made with oil and clay, an inch or two above the surface. This cavity is now filled with melted lead. The under side of the stamping hammer has a flat face of iron fitted into it, about the breadth and length of the die; this is called the licker-up. When the lead becomes solid, the hammer is raised to a certain height and let fall upon it. The under side of the licker-up, from being cut on the surface into teeth in shape like those of a rasp, firmly adheres to the lead, which afterwards rises with the hammer; the metal is now placed over the die, and the hammer, with its lead, made to fall upon it till the impression on the metal is complete. If the vessel to be stamped be of any considerable depth, two or three dies are often used, one larger than another, the last being of the proper size and shape. It sometimes happens that when the vessel has a long conical neck, they are obliged to have recourse to an auxiliary operation called drafting. Cylindrical and conical vessels are mostly formed by bending and soldering. The bending is performed on blocks of wood with wooden hammers, to avoid injuring the plated surface.

Vessels intended to have other forms are generally soldered up in a conical or cylindrical form, according as the width at the top and bottom of the vessel

varies. The metal is so malleable, even in the soldered part, that a skilful workman can give almost any form to a vessel with the hammer. Mouldings are sometimes formed upon the edges of vessels, which serve to give much strength and stiffness, as well as being ornamental. In forming substances which have a massive appearance, such as the feet of tea-urns, the handles of vessels, and plated table-spoons, no other metal is employed but the sheet. The mass is formed of two shells, which, when put together, form an apparent solid. Each of the concave parts is first filled with soft solder, they are then fitted accurately together, and heat applied till the mass fuses, so that the apparently massive article consists of a shell of plated metal filled with soft solder. Bulky ornaments in the form of shells and flowers are frequently put on in this way; some in silver: these have a similar massive appearance to, and strongly imitate, real plate. All goods formed by hand with the hammer require great labour in finishing; for, after hammering the vessel into the proper shape, the marks of the hammer appear like so many flat places, but these are removed from the outside of the vessel to the inside, when the inside is concealed, as in tea-urns: this is effected by covering either the anvil or the hammer with a piece of the stuff called everlasting. The roughness is transferred to that surface in contact with the everlasting. In hammering plated metal from time to time, it requires to be annealed by heating it red-hot; this discolours both the silver and the copper. These are cleaned by boiling in dilute sulphuric acid, and scouring with Calais sand. The sulphuric acid to the water is in very small proportion. If the silver begins to appear black by boiling, the acid is too much, and must be watered. When the vessels are finished in every respect by the maker, and the surface free from oxide, it frequently happens that bits of rosin used with soft solder adhere to it; this is removed by boiling in a weak solution of pearl ashes: the same is also used for cleaning the surface of tinned copper.

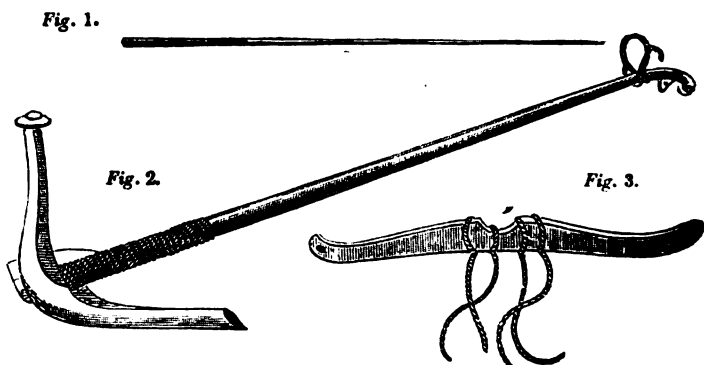
The second mode of operation we shall describe is the candlestick-making. In this branch of the business there is great variety. In the commencement of this trade, the object was chiefly to imitate those made of silver, and it began with the prevailing taste of imitating the different orders of architecture. The numerous points and prominences thus introduced were ill fitted for plated metal, as in a very little time their silver disappeared, which gave them the most shabby appearance possible. This obliged the manufacturers to make them more plain and simple, and it was not till the discovery of the silver edges that candlesticks of plated metal began to gain respect in the world of luxury and fashion. The stems of candlesticks have been made square; some with sharp, others with rounded corners; others oval, but the greatest number with round stems, which appear to be the most consistent and the most permanent. Of these, the patent telescope candlestick has had the greatest run: this consists in the cylindrical part lengthening and shortening at pleasure, by one tube sliding into the other. The feet of candlesticks, or the base, are generally made in a die by the stamp. The neck, which is sometimes small in one part, is also stamped. The dish part of the nozzle or socket is made in a die, and the tube part in the same way as the cylindrical pillar. These, for the sake of neatness and expedition, are generally drawn by the wire-drawing machine, whether for sliding or not. The prominent moulding and beads are generally of silver. The different parts are soldered together, some parts with hard, and others with soft solder. The branches of candlesticks are formed in two halves, like the tea-urn feet, &c.

Lastly, in forming such articles as are made of wire, such as bread-baskets, toast-racks, and castors, the wire is bent into the given form with a wooden block and a mallet. When pieces require to be soldered together, the joinings must be accurately fitted, in order to prevent the copper from appearing. In these cases hard solder is employed. This branch of plated manufacture admits of extensive application, wires being capable of a great variety of positions.

When the different plated goods come out of the hands of the workmen, the metal, although clean, is of a dull white colour, possessing no polish whatever

This last finish is called burnishing, and is generally performed by females, in a distinct set of apartments. The burnishing tools are generally made of blood-stone, and some of hardened steel finely polished; the latter are to burnish the minute parts which cannot be touched by the blood-stone, which are employed chiefly for the greater and uninterrupted parts. The bits of blood-stone are let into little cases, made of sheet iron, and then finely polished. The burnishers, if used dry, would adhere to the silver in some places, and would scratch instead of giving the fine polish: this is obviated by frequently dipping the burnishing tool into a solution of white soap. After being burnished they are raised, and lastly wiped with clean sheep's leather.

**PLOUGH.** An instrument employed in agriculture for breaking and turning up the soil in furrows expeditiously. The invention is of very remote antiquity. The most ancient of ploughs on record are still used in their simple primitive form in many parts of the East Indies. In the following figures are exhibited a correct delineation of one of these miserable machines, of which many

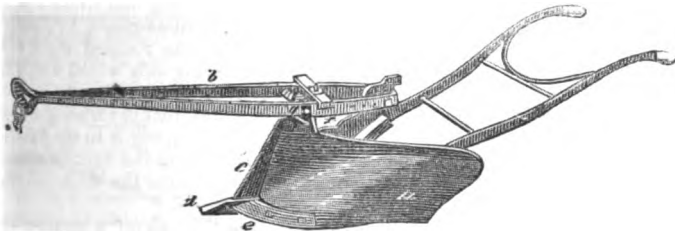


thousands are at this time engaged in tilling the land that supplies us with rice and other products of agriculture. *Fig. 2* is the plough, made of wood, the parts being bound together by ropes; *Fig. 3* is the yoke, designed for a pair of buffaloes. The husbandman holds the plough by one hand, while, in the other, he holds the goad, *Fig. 1*, with which, and his voice, he directs and stimulates the animals. The British manufacturer who may attempt to supply the Asiatic husbandman with better instruments, should, in our opinion, to a certain extent, copy the form represented, however he may improve upon it in the stability of his metallic substitute, and in the addition of convenient appendages, bearing in mind the well-known fact, that a workman who is used to a very inferior tool will, from habit, acquire a skill in using it which he could not exercise very readily with an intrinsically superior tool, differing materially from his previous one.

There are no instruments in which there are a greater variety of forms than ploughs. Every country in England, and almost every district, have their favourites, which, in the opinion of the operators, surpass all others in utility. The probability is, that the difference is not very great in the quantity or the quality of the work executed by them; and that such difference will, in general, be in proportion to the proximity or remoteness of the district, town, or city, where the construction of ploughs is conducted on the large scale, and upon scientific principles. As our limits will not permit us to give even a title of the varieties that are figured in the books, we shall confine the subject to the description of two modern improved ploughs (manufactured under a patent granted to George Clymer, of London), one designed for light and the other for heavy land; referring our readers who desire extended information on this important matter, to the *Ploughwright's Assistant*, by Gray, 1808; to the *British*

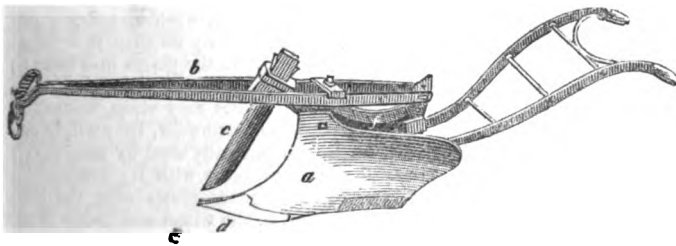
*Farmer and Ploughman's Guide*, by Finlayson, 1829; and to the article **AGRICULTURE**, in the *Oxford Encyclopædia and Supplement*.

A plough for light land is represented in the following cut, which is a perspective view. *a* is the breast; *b* the beam; *c* the coulter; *d* the coulter-point; *e* the share; *f* so much of the land side of the plough as can be seen. The beam rests upon cross pieces at the head of the plough, and is there secured loosely by a transverse screw-bolt *g*. The hind part of the beam is secured by a movable pin passing through it, and through one of the several holes in the land side; this pin being shifted from one hole to the other, and the beam *b* turning upon the bolt *g* as a fulcrum, it is raised or depressed, so as to adjust its



angle of inclination with the horizon at pleasure, causing thereby the plough to cut a deeper or a shallower furrow. The adjustment in a lateral direction is effected by placing several rings upon the bolt, by the shifting of which the direction of the beam, with respect to the land side, is altered, so as to make a broader or narrower furrow; and, by the same means, the plough is adapted to a single or double team of horses.

The plough for heavy land is very similar in its construction to the one just described, except the breast *a*, which is materially different, as shown in the following cut. *b* is the beam; *c* the coulter, which is of the old kind, that



being found the most efficacious in wet soils; it is fixed to an elongated part on the land side; *d* is the share. These ploughs are extremely light, and are put together, or taken to pieces, in a few minutes, being fastened together by a few screw-bolts; they are, therefore, extremely well adapted for exportation, and for use in hot climates. We have been informed by a practical agriculturist, who has several of these ploughs in use, that they turn the land well, and leave a particularly clean and even bottom.

**PLUMB-LINE.** An instrument used by builders, consisting of a leaden weight, or bob, suspended to the end of a line, used to determine the perpendicularity of their structures to the horizon.

**PLUMB-RULE.** A simple instrument, for the same purpose as the foregoing; but in this the bob is suspended to the end of a straight board with a line marked down the centre; so that when the edge of the board is placed

against the wall or other object, the plumb-line should exactly coincide with the line marked on the board, to be vertical; and the amount of deviation from the vertical line is precisely ascertained by the angle of divergence between the two lines.

**PLUMBAGO.** Graphite, or black lead, is an ore obtained from the mines of Keswick and Borradaile, in Cumberland, from Ayr in Scotland and other places. It occurs in beds of various thickness, and constitutes an important article in commerce. The finer kinds are boiled in oil, and afterwards sawn into the required pieces to make pencils. A considerable quantity is used for blacking and polishing the fronts of stoves and numerous other purposes. It has been very common to apply it, in its impure state, to reduce friction in machinery and rubbing surfaces; and, very recently, Mr. Lewis Hebert, of Chelsea, has applied it, in a very refined state, as a substitute for oil, in diminishing the friction of the rubbing parts of clocks. He applied it to a sidereal time-piece, in January, 1816, between which period and 1827 the time-piece was cleaned three times without renovating the plumbago; the friction places being only wiped with a fine muslin rag. In a communication to the Society of Arts, in 1827, eleven years after the plumbago had been applied only once, he states, that the time-piece was going as well as ever. He found a great difficulty in applying it to the jewelled pallets of the escapement, but obviated it by applying it to the friction plane of the teeth of the swing wheel; and he adds, "so ever since the clock has gone without oil."

The process of applying the plumbago is thus:—Take about a quarter of a pound of the purest black lead, the brighter the better; reduce it to a very fine powder in a metal mortar, and, to judge if it is fine enough, take a small pinch of it between your fingers; after rubbing it a few seconds, if it does not feel lumpy or gritty, but smooth and oily, it is good, and beaten enough; have a glassful of filtered water, take some of the powdered plumbago with the clean blade of a knife, spread it on the water, and stir it well; cover the glass, and let it stand for two or three hours; at the top of the water will be a kind of cream, skim it off with a card, and lay it upon a sheet of paper; when dry, put it in a box, to exclude the dust from it; put the sediment aside, repeat the process with some other water and plumbago, until you have acquired a sufficient quantity of fine powder for your purpose; when the whole of the powder is dry, pound it again in the mortar, or bruise it with the bowl of a silver spoon, upon a clean sheet of paper, and repeat the same process two or three times; if the lead is pure, no more sediment will go down; if some does, wash and dry it once or twice more: as soon as no sediment remains, you may be sure that the plumbago dust is pure, and cannot cause any mischief to the pivots and holes; pour some alcohol (the strongest spirits of wine,) into a small glass; having wiped the pivots of the wheels and the holes of the plates very clean, immerse them into the spirits, and immediately into the plumbago powder, they will be covered with it; take a small pencil brush, such as is generally used by miniature painters, dip it into the spirits, and fill the pivot holes with it; introduce some powder into them with your finger, by rubbing the plates over the holes till the powder is even with their surfaces; put in the wheel and make it revolve in the frame for five or six minutes; do the same to every wheel, and also repeat it two or three times; then the holes and pivots will be charged with a thin crust of plumbago, smoother than any polish you can give them; the piece will go twice as long without cleaning as with oil, and truly; if its movement is entirely secluded from dust, there will be no necessity of cleaning it for twelve years, which will be about the time for renovating the plumbago.

**PLUMBERY.** The art of casting and working lead. See the article *L&A* in this work; also *Nicholson's Practical Builder*.

**PLUNGER.** A long solid cylinder, sometimes used in force pumps instead of the ordinary pistons or buckets.

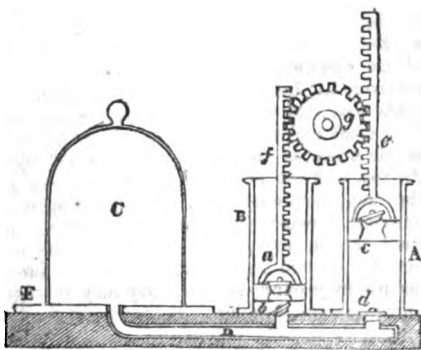
**PLUSH.** A kind of stuff having a sort of velvet nap or shag on one side, composed regularly of a woof of a single woollen thread and a double warp; the one wool, of two threads twisted, the other goats' or camels' hair. Some plushes in imitation of the foregoing are made of other materials.

**PLUVIOMETER.** An instrument for measuring the quantity of rain that falls in a given time. See RAIN-GAUGE.

**PNEUMATICS** treat of the mechanical properties of air, gases, and vapours. All air, gases, and vapours not in contact with the liquids from which they rise, partake of the same general properties; that is, they all possess weight and inertia, impenetrability, compressibility, and elasticity. The impenetrability of air may be made manifest by the impossibility of bringing together the opposite sides of a blown bladder. It may be also shown, by taking a cylinder with a smooth bore, and fitting a piston or plug into it so closely that the air may not pass between its sides and the tube; it will then be found that no power we can command will force the plug to the bottom of the cylinder. In making this experiment, however, we observe two of the most important properties of air, viz. its compressibility and elasticity; for although the plug cannot be forced to the bottom of the cylinder, yet it may be considerably depressed, so that the air is reduced to a much smaller volume, and, consequently, is compressible. On the withdrawal of the pressure another remarkable phenomenon presents itself, that is, the plug is forced upwards to its original position. The especial properties of air are as follows:—

- It possesses weight and inertia;
- It exerts an equal pressure in every direction;
- It is compressible and elastic.

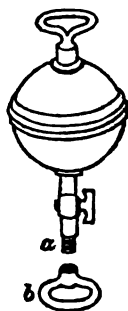
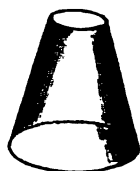
We shall speak of each of these properties in succession; but first it may be necessary to describe the air pump, an instrument which is in the highest degree useful in pneumatic experiments. In the annexed sectional representation, A and B are the barrels of the pump, which must be perfectly cylindrical and smooth within. C is a glass receiver placed upon the pump plate E; and D is a pipe communicating with the receiver and the two barrels: *b* and *d* are valves at the bottom of the barrels, opening upwards; *a* and *c* are valves in the pistons, which must fit into the barrels with the greatest accuracy; *e* and *f* are racks attached to the pistons, and which are moved upwards and downwards by means of the toothed wheel *g*, which is turned by a winch fixed on its axis. By comparing this instrument with a common water pump, its principle will be found identical; but as air is a much lighter and more elastic fluid, it will require the workmanship in the air pump to be of the most accurate description. In working this pump it will be seen that as the piston in B is raised, the air which previously filled only the receiver and the pipe D will be expanded by its elasticity so as to fill the barrel also; by the next motion of the handle the piston is depressed, and the air within the barrel becoming compressed will close the valve *b*, and open that at *a*, through which it will escape into the atmosphere. When the piston is again raised, the air left in the receiver will be again expanded so as to fill the barrel, and on being depressed, the air will escape as before. We have only in this process noticed one barrel, but the action of both is similar; while one is filling by the expansion of the air in the receiver, the other is emptied into the surrounding atmosphere. By this alternate action of the pistons, the air within becomes considerably rarefied, but as the portion withdrawn is always a definite part of what was previously in the receiver, it is manifest that a perfect vacuum cannot be obtained. We have stated that air has weight: this may easily be shown by means of the air pump. If we take a glass or other vessel holding exactly a quart, and furnished with a



stop-cock that will fit into the hole in the middle of the pump plate, we may exhaust or withdraw nearly the whole of the air from the vessel. Now, if we weigh the empty vessel, and afterwards, by turning the stop-cock, let in the air, the difference of weight in the bottle will show the weight of the quantity of air admitted: this will be about seventeen grains, varying at different times, both on account of changes of density which take place in the atmosphere, and the varying quantity of aqueous vapour that it may contain. The inertia of air may be seen in the resistance it offers to the motions of bodies immersed in it. Two sets of small brass vanes are sometimes put into motion by the same force under the receiver of an air pump. While the vanes in both are turned one way, they revolve for the same length of time whether in the air or in a vacuum; but if in one of them the broad surfaces of the vanes are turned in the direction of the motion, and in the other the narrow edges, a marked difference is observed. In an exhausted receiver they continue in motion during equal times, but in the air, that which cuts the atmosphere with its edges continues moving for some time after the other is at rest.

Another experiment illustrative of the same fact is termed the guinea and feather experiment. A long receiver is placed upon the pump plate, and a guinea and a feather are attached at the top to a little piece of apparatus by which they may be disengaged at the same instant. While the receiver is full of air, the guinea reaches the pump plate before the feather, but when the air is taken from the receiver, the guinea and feather fall with exactly the same velocity.

Since air is fluid, it will manifest the common properties of fluids; as, for example, pressure. If a small vessel, similar to the one here represented, be placed over the hole in the pump plate, and the hand placed closely over the top, when the pump is worked, the hand will be held firmly on the glass by means of the downward pressure. In the same way, the glass receivers are held firmly on the pump plate. If a bladder be made wet, and tightly stretched over the top of the glass, then dried and placed over the hole of the air pump, as soon as the pump is worked, the bladder will appear concave at the top, and will eventually be burst by the great pressure of the superincumbent air. Another apparatus, admirably adapted to evince the great pressure of the air in all directions, is what are termed the Magdeburg hemispheres. It consists of two hemispheres of brass, having their edges accurately ground, so that they may fit together, as in the annexed representation. The part *a* of the lower hemisphere is screwed into the hole of the pump plate, and the air may then be exhausted. If then the handle *b* be screwed on, two persons may endeavour to separate them by pulling in opposite directions, or they may be suspended, and a weight attached to the lower one. It has been ascertained that the actual amount of the air's pressure is about 15 pounds on every square inch of surface; hence may be calculated the force with which the hemispheres are held together, or the absolute pressure upon any surface whatever. Let us suppose that the diameter of the hemispheres is 4 inches, then the area of each of the circles in contact with each other will be  $12\frac{1}{2}$  inches, and multiplying this by 15 lbs. we obtain  $187\frac{1}{2}$  lbs. as the pressure by which the hemispheres are held together. In the same way we may ascertain the amount of pressure upon the human body. Suppose the outer surface of a middle-sized man to be about 14 square feet, then multiplying this by 2160 lbs. the pressure on a square foot, we obtain 30,240 lbs. as the pressure upon the body of an individual of moderate size. If the barometer should fall an inch, which it frequently does before rain, we are released from a pressure of upwards of 1000 lbs.: this, by diminishing the tension of the different parts of the body, is sufficient to account for that languor which is commonly complained of in bad weather. This apparatus was originally designed by Otto Guericke, of Magde-



lung, and was constructed on so large a scale that several horses were required to separate the hemispheres.

The ordinary or natural state of the air (as we are in the habit of calling it,) is a compressed state; if we attempt to alter it either by further compression, or by taking off the pressure, the elasticity or repulsion of the parts is immediately manifest. The law of compression within certain limits is exceedingly simple, and may be easily verified. Let a long glass tube be closed at one end, as in the accompanying representation. The longer leg may be 30 or 40 inches in length, the shorter 4. Suppose the tube placed in an upright position, and a little mercury poured into it up to the level *ab*, then a cylinder of air *bi* will be enclosed and prevented from escaping. If now more mercury be poured into the longer leg till it rise to *d* in the shorter, the height of mercury in the longer leg above the level *cd* will be found to be about 10 inches, which is  $\frac{1}{3}$  of the usual atmospheric pressure. The whole pressure upon the column *di* being made up of the pressure of the external air, together with that of the 10 inches of mercury, will be  $\frac{2}{3}$  of the atmospheric pressure, and the space now occupied by the air is  $\frac{2}{3}$  of the original space. If more mercury be added, so that the column may be 30 inches high, the whole pressure will be double the atmospheric pressure, and the space into which the air will be compressed is one-half. If we examine the result of a number of trials made in this way, we shall find them as follows:—



Compressing force . . . . .	1	$\frac{2}{3}$	$\frac{4}{5}$	$\frac{6}{7}$	$\frac{8}{9}$
Spaces occupied. . . . .	1	$\frac{3}{2}$	$\frac{5}{4}$	$\frac{7}{6}$	$\frac{9}{8}$

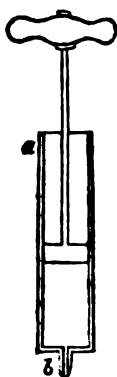
If we examine these two rows of fractions, we shall find that the lower are the reciprocals of the upper; whence we see that the spaces occupied by the compressed air are inversely as the compressing forces. But as the density is inversely as the spaces occupied, it is evident that the compressing force is proportional to the density; and further, since the elasticity of the included air is proportional to the compressing force, it is also manifest that the elasticity is as the density, that is, if the density be doubled or tripled, the elasticity will be doubled or tripled, &c.

The elasticity of air by the removal of the pressure gives rise to a variety of entertaining experiments. If a bladder containing a small portion of air be placed under the receiver of an air pump, while the air is exhausting the bladder will be observed to expand till it appears fully blown; on the re-entry of the air the pressure will immediately reduce the included air to its primitive dimensions, and the sides of the bladder will collapse. At the larger end of an egg there is a bubble of air between the shell and the inner skin: if a hole be made at the smaller end, and the egg be placed with the hole downwards in a wine-glass, under the receiver of an air pump, as soon as the air is begun to be withdrawn, the air within the egg will expand and force out the contents into the glass. When the air re-enters, by careful management, the whole may be forced into the shell, so as to have its original appearance. Upon this principle fountains may be contrived. If a glass or other vessel similar to the one here represented, having a tube reaching nearly to the bottom, be half filled with water, and then placed under a tall receiver on the pump plate, the action of the pump commences, the air in the part *a* not being able to escape, expands itself as the external pressure is removed, and forces the water before it up the pipe, so as to form a continuous stream till the level





of the water reaches the lower end of the tube. If the air in the part *a* could be compressed so that its elasticity might exceed that of ordinary atmospheric air, the fountain would act without being placed under a receiver. For this purpose a condensing or compressing syringe would be necessary to force air into the upper part of the vessel. The compressing syringe differs but little from one of the barrels of the air pump. It has, however, no valve in the piston, but one at the end *b*, opening outwards, and which may be easily formed by tying over the hole a small piece of oiled silk. When this apparatus is to be used, the end *b* is screwed into the mouth of the vessel into which air is to be forced; and the piston being then raised above the hole *a* in the side, the syringe becomes filled with air: the piston is then depressed, and the air is, by its descent, forced into the vessel, and from which it cannot return on account of the valve at *b* opening only downwards. The piston is again raised till above the hole, and another barrel full of air is injected into the receiver. This process may be continued till the air is considered of sufficient density, which may be easily ascertained by knowing the proportionate capacity of the syringe and the receiver. If the receiver contain twelve times as much as the syringe, twelve changes of the syringe will be necessary to double the density of the air. It is, perhaps, scarcely necessary to remark that the receiver must be strong and furnished with a stop-cock or valve, so that when the syringe is separated from it the air may not escape. For further information on this science, see **ATMOSPHERE, AIR, BAROMETER, &c.**



**PONDERABILITY** is a quality of bodies that relates to sensible weight. A ponderable body is one that possesses sensible weight. A great difference exists in the relative weights of different substances. Thus platinum is 23 times heavier than water; water 840 times heavier than air; and air 14 times heavier than hydrogen gas. Platinum is, therefore, 170,480 times heavier than hydrogen gas. It will readily be understood that if any substance exists that is as much lighter than hydrogen as hydrogen is lighter than platinum, the weight of such a body would be absolutely inappreciable by any of our present instruments; such bodies would, therefore, be called imponderable. In the ordinary division of simple substances at present in use by chemists, the whole are classed into ponderables and imponderables: the imponderable substances are, heat, light, and electricity. Some persons have supposed that the idea of imponderable matter is absurd, and that gravity is a universal property of bodies. However this may be, if we consider ponderability as indicating our ability to weigh the body, it will be manifest that heat, light, and electricity may, with considerable justness, be termed imponderable.

**PORCELAIN.** A fine kind of semi-transparent earthenware, in imitation of that made in China, and hence called China-ware. The combination of siliceous earth and argil is the basis of porcelain; and, with the addition of various proportions of other earths, and even of some metallic oxides, forms the different varieties of pottery, from the finest porcelain to the coarsest earthenware. Though siliceous earth is the ingredient which is present in largest proportion in these compounds, yet it is the argillaceous which more particularly gives them their character, as it communicates ductility to the mixture when soft, and renders it capable of being turned into any shape on the lathe, and of being baked. The clays are native mixtures of these earths; but they are often rendered unfit for the manufacture of at least the finer kinds of porcelain, from other ingredients which they also contain. The perfection of porcelain will depend greatly on the purity of the earths of which it is composed; and hence the purest natural clays, or those consisting of siliceous earth and argil, alone are selected. Two substances have been transmitted to Europe as the materials from which the Chinese porcelain is formed, which have been named *Kaolin* and *Petunse*. It was found difficult to procure in Europe natural clays equally pure, and hence, in part, the difficulty of imitating

the porcelain of the East. Such clays, however, have now been discovered in different countries; and hence the superiority to which the European porcelain has attained. The fine Dresden porcelain, that of Berlin, the French porcelain, and the finer kinds which are formed in this country, are manufactured of such clay, which, from the use to which it is applied, has received the name of porcelain earth, and which appears in general to be derived from the decomposition of felspar of granite. It appears, also, that natural earths containing magnesia are used with advantage in the manufacture. The proportion of the earths to each other must, likewise, be of importance; and from differences in this respect, arise, in part, the differences in the porcelain of different countries, as well as the necessity frequently of employing mixtures of natural clays. The argil communicates tenacity and ductility to the paste, so that it may be easily wrought; the silex gives hardness and infusibility; and on the proper proportion of these depends, in a great measure, the perfection of the compound. The proportion of silex in porcelain, of a good quality, is at least two-thirds of the composition; and of argil, from a fifth to a third. Magnesia is of use by lessening the tendency which the composition of silex and argil alone has to contract in baking, which is inconvenient in the manufacture. See POTTERY.

POROSITY is a term in physics, opposed to density, and signifies the relative proportion of matter and space included within the exterior superficies of a body. The volume of a body is the quantity of space included within its external surfaces. The mass of a body is the collection of atoms or material particles of which it consists. Two atoms or particles are said to be in contact when their nearer approach is resisted by their mutual impenetrability. If the component particles were in contact, the volume and mass would be identical; but there is good evidence to prove that the particles of no known substance are in contact. Hence it follows that the volume of a body consists partly of material particles, and partly of interstitial spaces, which are either empty or filled with some other different substance: these interstitial spaces are called pores. In bodies uniformly constituted, the component particles and pores are uniformly distributed through the volume; that is, a given space in one part of the volume will contain the same quantity of matter, and the same quantity of pores as an equal space in another part. The proportion of the quantity of matter to the magnitude of a body is called its density: if, of two substances, one contains in a given space twice as much matter as the other, it is said to be "twice as dense." The density of bodies is, therefore, proportionate to the closeness or proximity of their particles; and, consequently, the greater the density the less will be their porosity. The pores of a body are frequently filled with another body of a more subtile nature. If the pores of a body on the surface of the earth, and exposed to the atmosphere, be greater than the atoms of air, then the air will pervade the pores: this is found to be the case in many sorts of wood which have open grain. If a piece of such wood, or of chalk, or sugar, be pressed to the bottom of a vessel of water, the air which fills the pores will be observed to escape in bubbles, and to rise to the surface. If a tall vessel or tube, having a wooden bottom, be filled with quicksilver, the liquid metal will be forced by its own weight through the pores of the wood, and will be seen escaping in a silver shower from the bottom.

The process of filtration, in the arts, depends on the presence of pores of such a magnitude as to allow a passage to the liquid, but to refuse it to those impurities from which it is to be disengaged. Various substances are used as filters; but whatever be used, this circumstance should always be remembered, that no substance can be separated from a liquid by filtration, except that whose particles are larger than the pores of the filtering substance. In general, filters are used to separate solid impurities from a liquid. The most ordinary filters are soft stone, paper, and charcoal. When the liquid is of a corrosive nature, as some of the stronger acids, pounded glass is frequently employed.

All organized substances in the animal and vegetable kingdoms are, from their very nature, porous in a high degree. Minerals have various degrees of porosity. Among the silicious stones is one called hydrophane, which manifests its porosity in a very remarkable manner. The stone in its ordinary state is

semitransparent; if, however, it be plunged into water, when it is withdrawn it is transparent as glass: the pores, in this case, previously filled with air, are pervaded by the water, between which and the stone there subsists a physical relation, by which the one renders the other transparent. Oil or water placed on paper has a somewhat similar effect. A good method of observing the extreme porosity of woods, is to place a piece at the bottom of a vessel of water placed under the receiver of an air pump; during the exhausting of the receiver the air will be seen to issue from a thousand pores on the surface of the wood, and this emission will continue for hours. As the water enters the spaces previously occupied by the air, the body becomes heavier; and even charcoal treated in this way becomes heavier than water. Large masses of minerals, by their porosity, produce most important results: thus the rains which fall, and the snows that melt on the mountains, pass through the pores of the various substances they meet with, and issue forth to refresh the plains in spring which are the origin of the various magnificent rivers that at once fertilize and adorn our globe.

POTASH, or POTASSA, is the protoxide of potassium. It is called the vegetable alkali, because it is obtained in an impure state by the incineration of vegetables. Potash is always formed when potassium is put into water, or when it is exposed at common temperatures to dry air or oxygen gas. By the former method the protoxide is obtained in combination with water; and in the latter it is anhydrous. It consists of 39.15 parts, or 1 equivalent of potassium, and 8 parts, or 1 equivalent of oxygen. Hydrate of potash is solid at common temperatures; it fuses at a heat rather below redness, and assumes a somewhat crystalline texture in cooling. It is highly deliquescent, and requires about half its weight of water for solution. It is also soluble in alcohol. It destroys all animal textures, and, on this account, is employed in surgery as a caustic. It changes the blue colour of violets and cabbage to green; reddened litmus to purple; and yellow turmeric to a reddish brown. It has been called *lapis causticus*, but is now termed *potassa* and *fused potassa*. It is prepared by evaporating the aqueous solution of potash, in a silver or clean iron capsule, to the consistence of oil, and then pouring it into moulds. It may be purified by solution in alcohol and evaporation to the same extent as before, in a silver vessel. The operation should be performed as expeditiously as possible, to prevent the absorption of carbonic acid. A perfectly pure solution of potash will remain transparent on the addition of lime water; will not effervesce with dilute sulphuric acid, nor give any precipitate on blowing air from the lungs through it by means of a tube.

Pure potash, for experimental purposes, may most easily be obtained by igniting cream of tartar in a crucible, dissolving the residue in water, filtering, boiling with a quantity of quicklime, and, after subsidence, decanting the clear liquid and evaporating in a loosely covered silver capsule till it flows like oil, and then pouring it out on a clean iron plate. A solid white cake of pure hydrate of potash is thus obtained without the agency of alcohol; it must be immediately broken into fragments and kept in a well-stoppered phial. Potash is employed as a reagent in detecting the presence of bodies, and in separating them from each other. The solid hydrate, owing to its strong affinity for water, is used for depriving gases of hygrometric moisture, and is admirably fitted for forming frigorific mixtures. Potash may be distinguished from soda by a test recommended by M. Harkort. Oxide of nickel when fused by the blow-pipe flame with borax, gives a brown glass; and this glass, if melted with a mineral containing potash, becomes blue,—an effect which is not produced by the presence of soda.

POTASSIUM. A metallic substance, the base of potash: it was discovered by Sir H. Davy, in 1807. It was prepared by causing hydrate of potash, slightly moistened for the purpose of increasing its conducting power, to communicate with the opposite poles of a galvanic battery of 200 double plates; when the oxygen, both of the water and the potash, passed over to the positive pole, while the hydrogen and the potassium appeared at the negative. In this way only small quantities can be procured; but it may be formed more abundantly by the method of Guy Lussac and Thénard. This consists in

bringing fused hydrate of potash in contact with turnings of iron heated to whiteness in a gun-barrel. The iron deprives the water and potash of oxygen; hydrogen gas, combined with a little potassium, is evolved, and pure potassium sublimes, and may be collected in a cool part of the apparatus. Potassium may also be prepared by mixing dry carbonate of potash with half its weight of powdered charcoal, and exposing the mixture in an iron bottle to a strong heat: these methods have been improved by M. Brunner, who decomposes potash by means of iron and charcoal. From eight ounces of fused carbonate of potash, six ounces of iron filings, and two ounces of charcoal, mixed intimately, and heated in an iron bottle, he obtained 140 grains of potassium. If required to be quite pure, it must be re-distilled in a green glass retort. Potassium is solid at the ordinary temperature of the atmosphere; at 70° it is somewhat fluid, though its fluidity is imperfect till heated to 150°; at 50° it is soft and malleable, and yields like wax to the pressure of the fingers, but it becomes brittle when cooled to 32°; it sublimes at a low red heat, without undergoing any change, provided atmospheric air be completely excluded. Its texture is crystalline, as may be seen by breaking it when cold. In colour and lustre it is precisely similar to mercury. At 60° its specific gravity is 0.865, so that it is considerably lighter than water. It is completely opaque, and is a good conductor of heat and electricity. As this metal oxidizes rapidly in the air, or in fluids containing oxygen, it must be preserved either in glass tubes, hermetically sealed, or under the surface of liquids, like naphtha, which contain no oxygen. If heated in the open air it takes fire, and burns with a purple flame; it decomposes water instantly, and so much heat is disengaged that the potassium is inflamed, and burns vividly while swimming on the surface: the hydrogen unites with a little potassium at the moment of separation, and this compound takes fire, and augments the brilliancy of the combustion. Under water, a violent action ensues, without the emission of light, and pure hydrogen is evolved: it is also inflamed when placed upon ice, burning a little hole, which becomes filled with solution of potash. Besides uniting with oxygen, to form the protoxide and peroxide of potassium, it combines with chlorine, iodine, hydrogen, sulphur, and phosphorus. When potassium is placed in an atmosphere of chlorine, it spontaneously takes fire, and burns with greater brilliancy than in oxygen; the result is the chloride of potassium, which is also produced when chlorate of potash is decomposed by heat. Iodide of potassium is formed with emission of light when potassium is heated in contact with iodine. Hydrogen and potassium unite in two proportions, forming, in one case, a solid, and in the other a gaseous compound. The solid hydruret was made by heating potassium in hydrogen gas: it is a grey solid substance, easily decomposed by heat, or contact with water. The gaseous compound is formed when hydrate of potash is decomposed by iron, at a white heat, and it appears also to be generated when potassium burns on the surface of water. Sulphur unites readily by means of heat, and the compound sulphuret of potassium becomes incandescent at the moment of union. In like manner, phosphorus combines with potassium, forming phosphuret of potassium.

**POTATOES.** A bulbous esculent root, and forming the basis of several manufactures. Under the article **BREAD** will be found the description of a machine and process for separating the pure farina or starch from the others with which it is naturally combined. Under the heads **ALCOHOL** and **DISTILLATION** are also given the processes employed for the conversion of the potato into ardent spirit.

**POUNCE.** Gum sandarach, pounded and sifted very fine, mixed or not with the fine powder of the cuttle-fish bone, and used for rubbing on paper, to prevent the writing thereon from sinking or blotting.

**POWER,** in *Mechanics*, is the force which, being applied to any body, tends to produce motion, whether it actually produces it or not. In the former case it is called the moving power; in the latter, the sustaining power (See **HORSE POWER**.) The term *power* is likewise, for the want of a better word, applied to the six mechanical agents (as we prefer to call them), namely, lever, pulley,

inclined plane, wheel and axle, wedge and screw,—which see: also the article **MECHANICS**.

**POTTERY.** The art of making vessels from earth. In the earliest ages upon record pottery was manufactured. The chief establishments in England are in Staffordshire, in a district called The Potteries, at Worcester, Derby, Coal-port, and Liverpool. The potteries in Staffordshire employ many thousands of persons, and the value of their produce was estimated at 800,000*l.* per annum. The essential material of all pottery is clay, which of itself possesses the two requisite qualities of being in its natural state so plastic, that, with water, it becomes a soft, uniformly-extensible mass, capable of assuming and retaining any form, and, when thoroughly dried, and having undergone a red heat for a time, of losing this plasticity, and of becoming hard, close in texture, and able, more or less, perfectly to confine all liquids contained within its hollow. The most important circumstances requisite to be considered in selecting the materials for pottery are plasticity, contractibility, solidity and compactness after drying, colour, and infusibility. Wedgewood was the great improver of this manufacture. The processes employed at most of the manufactories are very similar, which may be classed under the following heads:—Preparation of raw material, moulding and turning, firing, printing, glazing, and painting. We shall describe these consecutively, as they are conducted at Spode's establishment.

In the *preparation of the raw material*, a powerful steam-engine performs many of the processes formerly carried on by manual labour. The bodies of earthenware are composed of Kent flint and West-of-England clay. The flint is first calcined in kilns, similar to those in which lime is burnt; it is then broken by revolving hammers, put in motion by the steam-engine, and afterwards conveyed into the pans, paved with stone, to be ground with water. In the centre of the pans there is an upright shaft, from which several transverse arms branch out, having very heavy stones placed between them: these stones, moved horizontally by the steam-engines, grind the flints, until they form a cream-like liquid, which is let off into the wash-tub, where the coarser particles are separated from the fine; the latter runs off into reservoirs, and the former is carried back to the grinding-pan. When the ground flint is wanted for use, it is conveyed from the reservoir by a pump, worked also by the steam-engine. The process of preparing the clay, and mixing it with the flint, is this:—The clay is drawn up into the upper chamber of the slip-house, and there thrown into an iron box, in which moves a shaft, with knives fixed in it, to cut the lumps into small pieces. The clay is now laid in a cistern with a proper quantity of water, where it softens, and is then put into the plunging-tub; in this tub the water and clay are stirred until they become thoroughly mixed. The liquid is now drawn off into another cistern, from which it passes through a silk sieve into a third cistern; then into a fourth, through silk sieves still finer; the ground flint and other ingredients are now brought and mixed together, and the whole passes through sieves of a greater degree of fineness into a fifth cistern: in this is a pump, that throws it into a trough for conveying it into the drying kiln. All these various operations are worked by the steam-engine, and there are fourteen sieves in motion at one time. After the clay has been dried it is taken from the kiln and laid together in large heaps, and, before it is worked into the vessels for which it is destined, the air bubbles are disengaged from it: this is done by a machine turned by the steam-engine. The machine is an iron box, shaped like an inverted cone, with an upright shaft in its centre, to which are affixed knives to cut the clay which is put into the box, by their rotatory motion, and, at the same time, so arranged as to force it downwards to a square aperture at the bottom; it escapes through this in a sufficiently compressed state for the workmen, and is then cut into square pieces of a convenient size, to be distributed in the manufactory. Near the steam-engine are workshops for those branches of the trade which require the aid of machinery; and in this building there are eight throwing-wheels and twenty-five turning-lathes. Underneath these shops are drying-houses, heated by steam, in which

the ware is dried, previously to its going to the oven to be fired; above the work-shops is a single room, capable of holding 200 workmen.

*Moulding and Turning.*—Tea-cups, saucers, basins, jugs, and such like vessels, receive their first shape from the hands of the thrower, who sits on a stool with a flat circular wooden wheel before him, moving horizontally on a pivot. This wheel is set in motion by the steam-engine, and the workman can increase or diminish its velocity as there is occasion. Upon the centre of the wheel the operator throws a lump of clay of the required size, and forms it into almost any shape, with the utmost facility; it is then cut from the wheel by a wire, and taken to be dried, that it may acquire sufficient hardness to fit it for the next operation. By turning, the superfluous parts of the clay are taken off, so as to render the article perfectly smooth, and to give it the exact shape. The lathes on which the vessels are turned are also put in motion by the steam-engine, and regulated as to speed by the turner himself. The principle of turning earthenware is very similar to that employed in wood turning. The vessels requiring handles and spouts are taken to the handling room, and those which do not want this appendage, after having attained the requisite hardness, are sent to the oven to be baked. The handles, made on a mould of plaster of Paris, are fixed to the vessel with a liquid mixture of the same material as the vessel itself.

For the formation of various articles manufactured in all potteries, moulds made of plaster of Paris are necessary. The modeller forms the shape of the intended vessel out of a solid lump of clay, which, after receiving his finishing touches, is handed to the person who makes the plaster mould from it. Plates and dishes are made from moulds of this kind, upon which the operator lays a piece of clay of the length, breadth, and thickness required; the mould and clay are then placed upon a wheel turning horizontally on a pivot; and the operator keeps peeling round with the left hand, and presses the clay to the shape of the mould with the other. The mould and dish together are then carried into a stove moderately heated, where it remains until sufficiently dried to separate. The plate or dish is then cut even at the edges, and in other respects finished: before they are baked the dishes are laid flat upon plaster or stone flags, that are quite level, in order that they may remain straight until they go to the oven to be fired. Tureens, vegetable dishes, and such articles, are also made in moulds, but require more time and care, being less simple in their form. Figures, flowers, and foliage in bas-relief are also formed separately in moulds, and afterwards affixed to the vessel with diluted clay.

*Firing.*—When the ware is ready for firing, it is placed in clay cases, called *saggars*, which vary in size and shape according to the articles placed in them. The *saggars* are put into an oven, shaped like a bee-hive, with an opening at the top; there is also an opening at the side to admit the *saggars*, but this is closed before the fire is applied. Each *saggar* is luted to the other by a roll of soft fire-clay; this secures the vessels contained in them from dust, the fumes of the fires, and from the effects of the air when the oven is cooling. The fires which heat the oven are placed round it in proper receptacles, which communicate with the interior of the oven by flues, heating every part equally. This first firing gives a higher degree of heat, and is continued much longer than any successive firing; when once fired, the article is called biscuit ware. The cream coloured, or queen's ware is now carried to the dipping-house, to receive its glazing; that which is to be printed blue is taken to the printing-house.

*Printing.*—The design is previously engraven on a copper plate, and laid on a stone to warm. The colour (which has oxide of cobalt for its basis) is mixed with a preparation of oils, to fetch out the impression; this mixture is smeared over the surface of the plate and again cleaned off, leaving the liquid in the engraving only. The paper used to take off the impression is made expressly for this purpose; it is damped, laid on the copper plate, and passed between two iron rollers, as in ordinary copper-plate printing. The design, being transferred to the paper, is laid immediately upon the ware, being rubbed on with a flannel. After remaining a short time, the ware is put into a tub of water, and the paper is separated from it by a sponge, leaving the design in the most perfect state.

The ware is then dried, and taken to the oven to be burned; during this operation, the oil which has been mixed with the colour in the printing is destroyed, and the oxide of cobalt more firmly attached to the ware; it is then glazed.

*Glazing.*—The glaziers differ in their composition in all manufactories; most, however, have oxide of lead for their basis. The ingredients being mixed with water, and well ground, the glaze is ready for use, in which the vessels are dipped. On drying, which takes place instantly, the water contained in the glaze being absorbed by the porosity of the vessel, it is covered with a fine white powder, of a regular thickness; this, when fired, becomes vitreous, or assumes a glass-like appearance, and, from its transparency, the blue pattern underneath is rendered perfectly visible. In the last firing, especial care is taken to keep one piece from touching the other, or the whole would fuse into one united mass. Great attention is also requisite in the firing, not to give too much or too little heat, either extreme being injurious: the fireman in this, as in the other firing, draws out trial pieces from the oven, with an iron rod, to ascertain the proper degree of heat.

*Painting.*—The pieces of porcelain or earthenware to be enamelled and enriched by gilding, are, after the first firing, dipped in a suitable glaze, and again submitted to the fire; they are then delivered to the painter or enameller. The colours used in enamel-painting are composed of metallic calxes and fluxes, suitable to each other, separately and conjointly, and of such a nature as to fuse them sufficiently for the glazing on which they are laid. Gold has also its flux, and is laid on as other colours are. When the painting is completed, the ware is placed in a furnace less in size, and different in construction, from that before noticed. Care is here necessary in the arrangement of the vessels, and great nicety is required in the degree and the continuation of the heat, which is not so intense as in the former firings. The colours after this firing put on a shining appearance, but the gold has an opaque yellow cast, and is burnished with a blood-stone to give it the desired brilliancy.

The deleterious effects of glazes, composed principally of lead, having engaged the attention of the Society of Arts, they were induced to offer their largest honorary premium for the discovery of a glaze for the common red pottery, composed of materials not any ways prejudicial to the health, and which, from its cheapness and fusibility, at the comparatively low temperature required by red pottery, might supersede the use of lead in that branch of manufacture. The following method was communicated to the Society by Mr. Meigh, of Skelton, for which the Society awarded him the premium:—The vessels are to be first dipped in a mixture of red marl, ground in water to an impalpable paste, in order to fill up the pores with the fine particles of the marl; the vessels are then glazed with a mixture of the consistence of cream, of equal parts of black manganese, glass, and Cornish stone, well ground and mixed together, and when the ware is well dried it is fired as usual. For a white glaze, the manganese is omitted.

Owing to the vast extent of the manufacture of refined sugar in this country, there is a very great and constant demand for sugar-loaf moulds, which are a species of unglazed red pottery, made upon the potter's wheel. Messrs. T. and R. Powell, of Bristol, however, by an improved patent process, now form them upon a mould, preparatory to turning, and afterwards give them a glaze both inside and out. The machinery employed by the patentees is represented in the following *Figs. 1, 2, and 3.* *a*, *Fig. 1*, represents the mould formed of wood or plaster of Paris, or both, and turned perfectly smooth; it has a cylindrical pin *b* in the apex, and in the centre of the base, a hole to receive the head of an upright spindle *c*, which projects about an inch through the disc *d*; upon this disc the mould is placed, a small pin from *d* entering a hole in the base to carry it with the disc, when the spindle (which is placed at the potter's table,) is set in motion by a band passing round the pulley *e*.

*Fig. 2* represents the press in which the clay is prepared for the mould. *a* *e* the cheek of the press; *b*, a stout triangular box secured to the sides of the press, of the shape shown by the dotted lines on *Fig. 3*; *c*, a table supported by hinges at one end, and at the other by wedges resting on the frame *e*; a flat

board *f*, (shown separate in *Fig. 3*.) is placed upon the table under *b*; in the box *b* is a thick plank, of the shape of an interior of *f*, and across *b* is placed a stout block of wood *g*, which is retained in its place by iron straps *h* bolted to *b*, and having forelocks passing through the top of them; in *g* works the screw *k*, its upper end being steadied by the cross-piece *l*, and the lower end pressing upon the thick plank in *b*.

*Fig. 3* represents the plank *f*, which is half an inch thick, and having a piece taken out of the centre (as shown in the figure); the dotted lines represent the exterior shape of *b*, the interior being the same as *f*. The operation is as follows: the plank *f* being placed on the table and alided under *b*, the table is

Fig. 1.

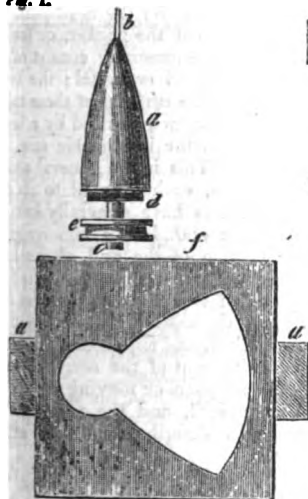
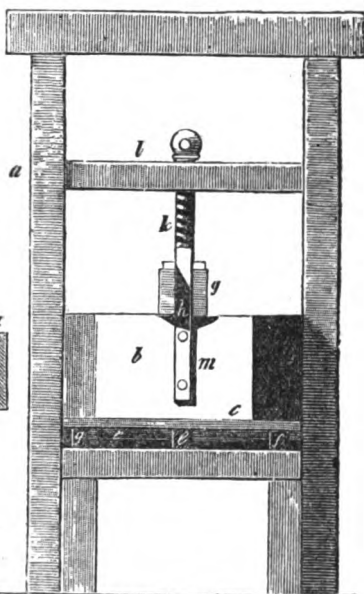


Fig. 3.

Fig. 2.



wedged up, and the forelocks are withdrawn from the straps *h*; the block *g* and screw *k* are raised by a rope; the box *b* is then to be filled with clay, and covered with the thick plank before mentioned; *g* is then replaced, and the forelocks driven in: the screw being now turned, presses the clay into the mould plank *f*; a wire is then drawn through between the plank *f* and the box *b*; the wedges being knocked out, the plank *f* is withdrawn, and replaced by another, and the table again wedged up. The piece of clay in *f* is then to be removed, and placed upon the mould *Fig. 1*, round which it is wrapped, the edges closed together, and then turned fair and smooth: it is afterwards removed, when sufficiently dry, to the kiln; and when burnt enough, the salt glaze is given in the usual manner. Instead of the box *b*, a number of planks like *f* may be placed upon each other, and being firmly clamped together, the clay may be pressed into them by the screw, and then being unclamped, a wire may be passed between each, which thus gives the clay ready for the turning mould.

**PRECIPITATE.** When a body, dissolved in a fluid, is either in the whole or in part made to separate and fall down in the concrete state, the act of falling is termed precipitation, and the matter fallen is called a precipitate.

**PRESS.** A machine for the compression of any articles or substances, by the application of screws, levers, wedges, &c. in a convenient manner. As the



combinations of the mechanical powers are almost illimitable, it follows that there may be presses made of an almost infinite variety of forms; but by no possible combination or arrangement of the mechanic powers, can any power be obtained: that must be derived from manual labour or some other moving force; and as no motion can take place in any machine without a loss from friction of some portion of the original force applied, that press which imparts the greatest mechanical energy, with the least proportion of friction, and in the most convenient manner, is the best. It however happens in most cases, that friction is reduced in proportion to the excellence of workmanship or perfection of form; and as this circumstance enhances the cost, a preference is often given to machines of rude construction, and of less convenience in form. Under the article OIL we have described a variety of presses of very simple construction, but of great energy and little cost; they are, however, for the most part, not sufficiently compact and convenient for the operations of the packer, or for the general purposes of our manufactories. Screw presses generally consist of six members or pieces; viz. two flat smooth tables of wood or metal; the lower one fixed, and the other above it movable. Between the surfaces of these tables the goods to be pressed are laid, and one or more screws, worked by a lever, are made to force the movable table or board towards the immovable one, and thus produce the pressure on the interposed body. This is the general nature of the machine, of which there are many varieties, each adapted to its own particular purpose. The most modern screw-presses have generally but one screw, preferably made of iron, which, at its lower end, has a massive globe head, with four holes through it, for the reception of the end of the lever employed to turn the screw; the thread of the screw passes through a nut fixed fast in the head or top of the frame of the press. The frame, in this case, consists of a lower bed or horizontal piece, on which the matters to be pressed are laid, two upright cheeks being firmly united with it, and supporting the head, or upper horizontal pieces of the press, in which the nut of the screw is fixed; the lower point of the screw is united with the follower, or moving bed of the press, and this rests upon the substance to be pressed, and the power of the screw forces it down upon it. A press of this kind is described under the article HOT-PRESSING, but adapted to the latter object.

Another kind of screw-press consists of two screws, which are immovably fixed in the lower board or bed; and passing through holes in the upper board, have nuts upon them, which, being turned by a lever, draw the two boards together, and exert a pressure upon any thing placed between them. Sometimes the screws pass through the upper board, and are tapped into the lower one; then the screws themselves are turned round by a lever put through their heads instead of turning the nuts. Presses of this kind, when accurately made, have a communication with wheel-work, from one screw to the other, so that both shall turn round together, and cause the two boards of the press to advance parallel to each other. The bookbinder's cutting press is a modification of this, and is used by bookbinders, stationers, and others. See BOOKBINDING.

The screws for presses were formerly made of wood, with sharp threads; that is, the worm of the screw, if cut across, would make a triangular section, the base thereof abutting upon the cylinder of the screw. In this method it was necessary to have the threads very coarse, to give them sufficient strength, and then the power of the screw was not so great as in the other presses, where the screws are made of iron, and their threads not above one-third or one-fourth the distance asunder; the tenacity, hardness, and smoothness of the metal also diminishes the friction considerably. The frames of the modern presses are also made of iron, wood being found incapable of permanently resisting the great strain to which they are subject, as all the fibres, even of the hardest oak, become separated into ribands, and then break, one at a time, till the whole beam fails.

An excellent modification of the screw-press was invented and patented by Mr. Daniel Dunn, of Pentonville, which is adapted to a variety of uses; the following is a description:—Instead of the simple lever, consisting of a long straight bar, which requires so large a space to move it in, the patentee uses a compound lever (much like those employed in the ordinary printing press). by

which means the same power is obtained in a much more compact apparatus. *Fig. 1* represents an elevation of the complete press, and *Fig. 2* a plan of the improved part of the machine; the like letters in each figure denoting similar parts. *a* is the bed of the press *b b* of massive oak; *b b* the cheeks or side framing; *c* the head; *d* the nut fixed into the head, through which the screw *e* is turned; *f* is the platten; *g* the goods, together with the press-boards or metal plates between them. Thus far the press is like others; but instead of having a large screw-head, with apertures, for the insertion of a long lever bar, that part of the screw is squared, and on it is fixed a circular metallic plate or wheel *h*, with a double row of ratchet-teeth; one of the rows of teeth project horizontally from the periphery, the other vertically, as will be understood upon examining both figures. *i* is the handle of the compound lever, which, being formed into a circular eye at the farthest extremity, is thereby fixed upon, and traverses up

Fig. 2.

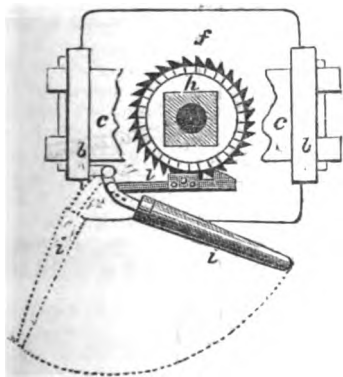
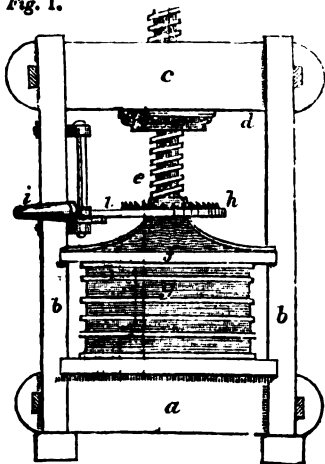


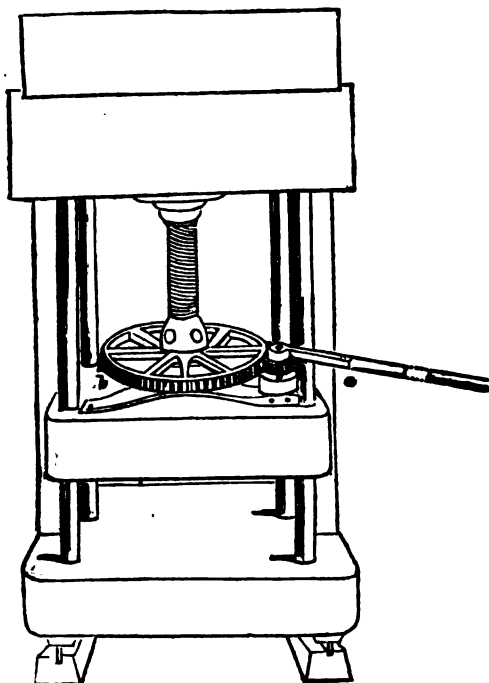
Fig. 1.



and down the fulcrum *k*, which is an upright bar firmly bolted to one of the cheeks of the press. To alter the power according to circumstances, the curved end of the handle *i* is perforated with several holes, to receive a key or bolt, which fastens the other portion *l* of the compound lever to it (best seen in *Fig. 2*); the extremity of *l* is hooked or notched so as to take hold of the teeth of the ratchet-wheel, and it has a plate screwed on to it at *o* to prevent it from falling off. To support the compound lever at the required elevation, a stent pin is passed into a hole, of which there are a series made for the purpose in the side cheek. In operating with this press, the goods are laid upon the bottom board in the usual manner; the platten *f* is then brought down by turning the ratchet-wheel round by hand. The pressure is then given by pulling back the handle *i* in the direction, and to the position, shown by dotted lines in *Fig. 2*; by repeatedly moving the handle in this way, the ratchet-wheel is drawn round by the lever, which causes the screw to descend and to force the platten against the goods: during this operation it will occasionally be necessary to let the lever descend upon the fulcrum, by taking out the supporting pin, and putting it into the next hole beneath. When it is required to unscrew the press, the hooked end of the lever *l* is placed in contact with the circle of teeth on the upper surface of the ratchet-wheel; the lever being then pulled the reverse way, the screw is raised, and the pressure taken off.

A very substantial and practical standing press has been made by Mr. J. L. Pouché, type-founder, of Holborn: it is particularly designed for the use of bookbinders, stationers, and printers; the arrangement dispensing with the long

inconvenient lever, as in Mr. Dunn's. It is represented in the following perspective outline. There is little in its structure that varies essentially from other presses of the kind; the head, bed, cheeks, screw, and nut, may be regarded as the same. The chief novelty consists in employing, in addition to these parts, a toothed wheel *b*, fixed on the axis of the screw, and operating upon it by the small pinion *c* turned by the lever *d*, which fits on the square end of the axis of *c*, whereon it is shifted at every fresh pull. The power of



the press, when brought down to the work, may thus be increased in proportion to the difference of the diameters between the large wheel and the little pinion; the slow operation of the press at this time is of little consequence. This press stands in but little room, considering its mechanical efficacy, and it is manufactured at a low price.

The foregoing are sufficient examples of the construction of screw presses; we shall therefore proceed to give a description of a most ingenious, cheap, and effective press, in which all the other mechanical powers are brought into operation; viz. the *wheel and axle*, *lever*, *wedge*, *inclined plane*, and *pulley*. It is one of the inventions of Mr. Ewings, a talented member of the London Mechanics' Institution, who obtained for it Dr. Fellowes's annual prize of ten pounds. This press, which is applicable to the packing of goods, pressing of juice from fruits, oil from seeds, or other purposes to which the screw-press is usually applied, consists of a frame-work, and two or more blocks or beams, between which the articles to be subjected to pressure are to be placed; and these vary in form, size, and material, according to the purposes for which they are intended. Mr. Ewings does not claim any novelty in the construction of these parts, but only in his method of producing the pressure, which is effected by bringing together the pieces that act on the articles to be pressed by

wedges; these are forced in by levers (in the manner represented by the following figures 1 and 2), in both of which the same letters of reference represent similar parts. *a* is the base of the press, furnished at each end with ratchet notches *bb*, which constitute the fulcrums of the levers *hh*; *c* is the top of the press, supported by the frames *dd*; and *ee* are the pieces acting on the goods, either downwards, upwards, or both, according as the pressure may be required: in *Fig. 1* it is represented acting upwards; and in *Fig. 2* it is represented acting both ways: *ffff* are friction rollers, between which the wedges *gg* are projected. A cord is fixed to a hook on the end of one of the levers, and passing over a pulley *k*, on the end of the other, is attached to a small drum *l*, which is furnished with a ratchet-wheel and pall, and is turned by a

Fig. 1.

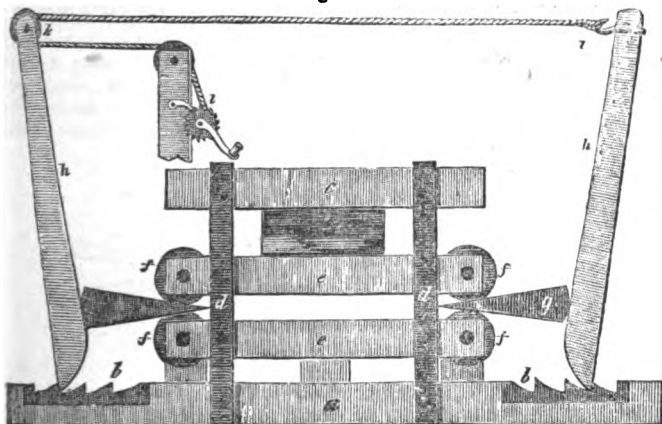
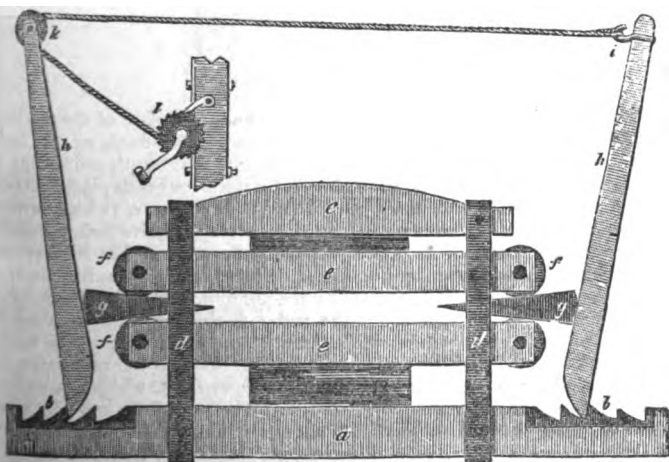


Fig. 2.

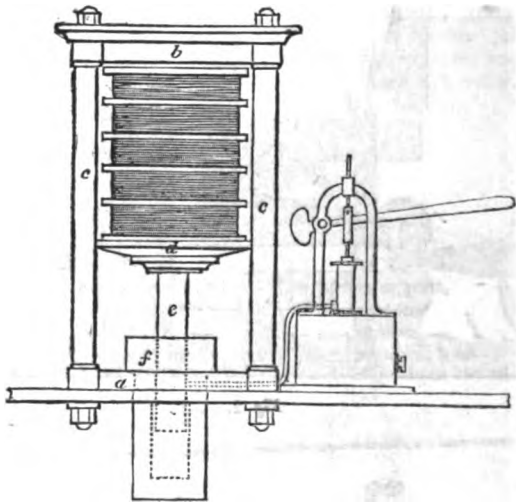


winch. We have seen other modifications of Mr. Ewings's press, but we have selected the above as best calculated to show the principle of its action. Amongst the advantages of this press have been noticed the simplicity and economy of its construction, as it may be made by almost any person accustomed to handle carpenters' or smiths' tools, of very cheap materials; and also

the facility with which its power may be varied: it may be diminished or increased to any extent, simply by changing the form of the wedges; but the drawings exhibit its various applications and mode of operation so obviously as to preclude the necessity of further remarks.

We shall now proceed to the consideration of those presses wherein the power applied is communicated through the medium of an incompressible fluid.

The hydrostatic, or water press, as it is sometimes called, was first brought into a practical form by the late Mr. Joseph Bramah, and was patented by him in 1796. Since this period it has undergone many new improvements in the constructive department, which, although they have not sensibly added to its mechanical energy, have materially added to its convenience, by rendering its operation more easy and certain. The following diagram is explanatory of the



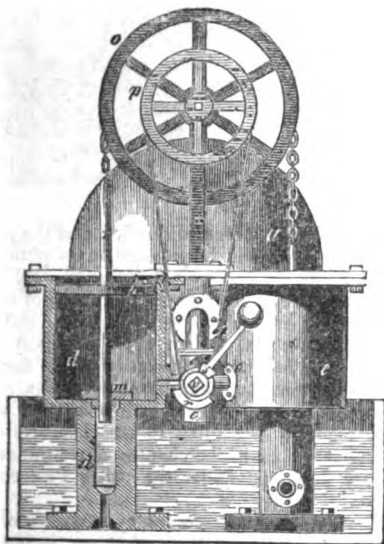
principle upon which it acts. *a* represents the foundation plate of the machine, and *b* the head-plate, connected together by four strong standards *cc*; the latter should be of wrought iron; and the whole of the utmost strength and solidity, to resist the entire force of the press, which is exerted upon the goods placed between the follower *d* and the head of the press. The piston or ram *e*, (which supports the follower and goods) moves up and down in a very massive hollow cylinder *ff*, bored very accurately at its upper part to fit the ram, and at its lower end somewhat widened, as shown by the dotted lines, to admit a small quantity of water, which is forced into it by a small force-pump *g*, along the pipe *h*. Just above that part of the cylinder where the water discharges itself in a minute crevice, an annular cavity is formed around the cylinder, wherein is fitted a folding collar of leather, which presents a thin edge both to the ram and to the cylinder, to render the junction between them water-tight, which it does most effectually by the action of the pressure itself. The top of the cylinder where the ram emerges from it, is provided with a stuffing box, well packed, and secured by a covering plate. Now if we suppose the area of the valve by which the water is admitted into the cylinder to be one-eighth of an inch (as usual) and the power applied thereto by the lever of the pump to be a ton, and the area of the section of the ram to be 64 inches, we have  $64 \times 64 = 4096$  tons applied to the goods in this press, according to the known laws of the pressure of fluids, as explained under the article HYDROSTATICS. The power mentioned is unnecessarily great for the general purposes of a press; but it

obvious that it may be reduced to any required extent by altering the proportions of the lever, the valve of transmission, and the ram ; and it is equally obvious that the power may, by other modifications, be increased to an indefinite extent.

It should, however, be noticed, that in the hydrostatic press of Bramah, in common use, the same time is occupied in pumping against a small, as against a great resistance : in almost all cases the operation is commenced when the resistance is at a minimum : during the process the increase is gradual, and at the termination the resistance is at a maximum. As a remedy for this practical inconvenience, hydrostatic presses are generally made with two levers of different powers, with the view of changing the power at some time during the process. Notwithstanding this provision, however, the time and trouble attending the change, renders its assumed advantages a doubtful question of economy, and it is, consequently, rarely resorted to in practice.

To obviate these objections, Mr. James Murdoch has proposed a self-regulating hydrostatic press, in which the change of power proceeds in the same ratio as the resistance, without any care or interference on the part of the operator. The ingenious arrangement proposed will be comprehended by the annexed drawings, marked *Fig. 1* and *Fig. 2*, together with the following description :—

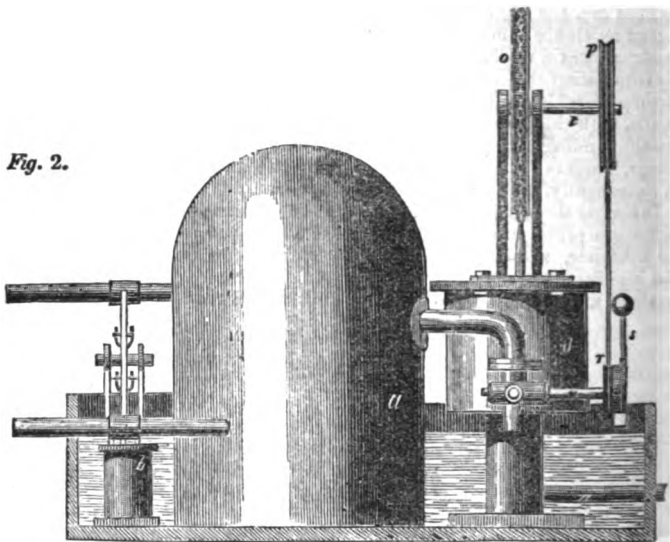
*Fig. 1.*



*a* represents the vacuum chamber, being similar to the exhausted receiver of an air-pump ; *b* a double-barrelled air-pump ; *c* a four-way cock, connecting *a* with *d* and *e*, the two force pumps, and its lower end communicating with the atmosphere ; *d* is a section of one of the force pumps ; *f* is the plunger, working through the stuffing-box *m*, and having a solid piston *h* keyed on to it, which works air-tight in the enlarged part of *d* ; *g* is a valve opening upwards ; *n* the exit pipe, leading to the press, which is not here shown, it being of the usual construction ; *o* is a wheel, over which passes a chain connecting the two plungers ; it is fixed square on the axle *t*, as is the wheel *p*, which serves to turn the cock by means of a cord passing round it and *r*, which is a pulley playing loose on *v*, and having a projecting shoulder on its lower part ; *s* is a key fixed square on *w*, having shoulders at its lower end, and a weight at its upper end ; *v* is a rod attached to the plug of the cock *c*. The action is as

follows: suppose the pistons in the situation shown in *Fig. 1*, the enlarged chamber of the forcing pump *d* is now open to the vacuum chamber *a*, and the chamber of *c* is open to the atmosphere *s*; the lower barrel of *d* is full of water. Upon rarefying the air in the vacuum chamber *a*, by means of the air-pump *k*,

*Fig. 2.*



the air in the chamber *d* likewise becomes rarefied, and the piston *h* will descend as soon as the pressure on it exceeds the pressure on the plunger *f*, and a portion of water is thus forced into the press by the pipe *n*. By the descent of the piston *h*, the wheel *o* revolves, and brings up the piston of the chamber *e*; the smaller wheel *p* is carried round at the same time, and turns the cock *r*, the shoulder on which, taking the shoulder on *s*, carries it round a little past the vertical line, when it (*s*) falls into the position of the dotted line, and opens *e* to the vacuum chamber, and *d* to the atmosphere. The air under the piston of *e* now becomes rarefied, and it descends in like manner as the other. The larger the vessel *a* is made in proportion to the chambers *d* and *e*, the better will the press accommodate itself to the changes of resistance.

Printing presses are described under the article PRINTING: see also OIL, COPYING-MACHINE, &c.

**PRINTING.** The art of taking copies by impression of type, engraved plates and blocks, or of any design or work whatever, in black-ink or pigments of various colours; but the word *printing*, standing alone, without any distinctive addition, is usually understood to imply typography, or printing from type, usually called letter-press printing, which we propose to notice in the first place.

It is a remarkable circumstance, that notwithstanding the art of letter-press printing has formed a new era in the history and character of our species, the origin of its invention is involved in mysterious obscurity. The primitive honour of having given birth to this sublime vehicle of knowledge has been claimed by the Italian, the German, the Dutch, and the Swiss nations. The inhabitants of Mentz, Strasbourg, and Haerlem, seem to have the most solid ground for their boastings; but we are bound to state, that the citizens of Venice, Rome, Florence, Basle, Augsburg, and Dordrecht, certify to the contrary thereof. The discussion of this interesting question not according with the nature of our work, we recommend those of our readers who are solicitous

for information upon the early history of the art, to the article *PRINTING*, in the *Oxford Encyclopædia*. We may, however, observe, that it seems to be admitted by all parties that this invention took place about the year 1440, and was brought to England by William Caxton, who set up his first press in Westminster Abbey, and began to print books some time after the year 1471. In the early stages of the art, the impressions were taken off with a list coiled up, such as the card-makers use at this day; but when they came to use single types, they employed stronger paper, with vellum and parchment. At last the press was introduced, and brought gradually to its present state. The same observation applies to the ink; at first the common writing ink was employed; and the printing ink of lamp-black and size, and lamp-black and oil (that now used) were introduced by degrees. We shall now proceed to explain the printer's art, as it is practised at the present day; premising that it is divided into two branches, *composition*, or the arrangement of the types; and *press-work*, or the taking off impressions from types so arranged: the workmen employed are therefore distinguished into two classes,—“compositors” and “pressmen.” Each compositor works at a sort of desk, called a frame, and, in most instances, he has a desk or frame to himself. The frames project laterally from the wall. At intervals there are large tables, with stone tops, technically called imposing-stones. Each frame at which a compositor works is constructed to hold two pair of cases; each pair of cases contains all the letters of the alphabet, whether small letters or capitals, as well as points, figures, &c. &c. One of these pair of cases is occupied by the Roman letters, the other by the Italic. The upper case is divided into ninety-eight partitions, all of equal size; and these partitions contain two sets of capital letters, one denominated “full capitals,” the other “small;” one set of figures, the accented vowels, and the marks of reference for notes. The lower case is divided into partitions of four different sizes; some at the top and ends being a little smaller than the divisions of the upper case; others nearer the centre, being equal to two of the small divisions; others equal to four, and one equal to six; in all there are fifty-three divisions in the lower case. The inequality in the size of the cells in the lower case is to provide for the great differences as to the quantity required of each letter. According to the language in which it is used, one letter is much more wanted than another, and the proportions required of each have been pretty accurately settled by long experience. As some of our readers may be curious to know these proportions, as they apply to the English language, we subjoin the type-founders' scale for the small characters of a fount of letter, of a particular size and weight:—

a . . . . .	8,500	n . . . . .	8,000
b . . . . .	1,600	o . . . . .	8,000
c . . . . .	3,000	p . . . . .	1,700
d . . . . .	4,400	q . . . . .	500
e . . . . .	12,000	r . . . . .	6,200
f . . . . .	2,500	s . . . . .	8,000
g . . . . .	1,700	t . . . . .	9,000
h . . . . .	6,400	u . . . . .	3,400
i . . . . .	8,000	v . . . . .	1,200
j . . . . .	400	w . . . . .	2,000
k . . . . .	800	x . . . . .	400
l . . . . .	4,000	y . . . . .	2,000
m . . . . .	3,000	z . . . . .	200

The proportion in which a particular letter is required renders it necessary that the cells of the lower case should be arranged, not as the letters follow each, alphabetically, but that those in most frequent use should be nearest the hand of the compositor. The point to which he brings the letters, after picking them up out of their cells, is not far removed from the centre of the lower case; so that in a range of about six inches on every side he can obtain the c, d, e, i, a, m, n, h, o, p, u, t, a, and r, the letters in most frequent use. The



spaces, which he wants for the division of every word, lie close at his hand, at the bottom of the central division of the lower case. It must be quite obvious, that the man who contrived this arrangement saved a vast deal of time to the compositor.

The cases, particularly the upper one, are placed in a sloping position, that the compositor may the more readily reach the upper boxes. The instrument in which the letters are set is called a composing-stick, which consists of a long and narrow plate of iron, brass, or other compound metal, on the right side of which arises a ledge, which runs the whole length of the plate, and serves to sustain the letters, the sides of which are to rest against it; along this ledge is a row of holes, which serve for introducing the screw, in order to lengthen or shorten the extent of the line, by moving the sliders farther from, or nearer to, the shorter ledge at the end. Where marginal notes are required in a work, the two sliding pieces are opened to a proper distance from each other, in such a manner as that, while the distance between forms the length of the line in the text, the distance between the two sliding-pieces forms the length of the lines for the notes on the side of the page.

Before the compositor proceeds to compose, he puts a rule or thin slip of brass-plate, cut to the length of the line, and of the same height as the letter, in the composing-stick, against the ledge, for the letter to bear against. Thus prepared, the compositor having the copy before him, and his stick in his left hand, his thumb being over the slider; with the right hand he takes up the letters one by one, and places them against the rule, while he supports them with his left thumb by pressing them to the end of the slider, the other hand being constantly employed in setting in other letters, which is effected by a skilful workman at an average rate of about thirty per minute. A line being thus composed, if it end with a word or syllable, and exactly fill the measure, there needs no further care; otherwise more spaces are to be put in, or else the distances lessened between the several words, in order to make the measure quite full, so that every line may end even. The spaces here used are pieces of metal exactly shaped like the shanks of the letters; they are of various thicknesses, and serve to preserve a proper distance between the words; but not standing so high as the letters, they make no impression when the work is printed. The first line being thus finished, the compositor proceeds to the next; in order to do which he removes the brass rule from behind the former, and places it before it, and thus composes another line against it after the same manner as before; going on thus till his stick is full, when he empties all the lines contained in it into what is called a galley, which consists of a flat piece of mahogany, or other fine wood, with a ledge of a proper height at the margin of its two sides. The compositor then fills and empties his composing-stick as before, till a complete page is formed; when he ties it up with a cord, and, setting it by, he proceeds to the next, till the number of pages constituting a sheet is completed; which done, he carries them to the imposing-stone, there to be ranged in order, and fastened together in a frame called a chase,—and this is termed imposing. The chase is a rectangular iron frame, of different dimensions, according to the size of the paper to be printed, having two cross-pieces of the same metal, called a long and short cross, mortised at each end, so as to be taken out occasionally. By the different situations of these crosses, the chase is fitted for different volumes; for quartos and octavos one traverses the middle lengthwise, the other broadwise, so as to intersect each other in the centre; for twelves and twenty-fours, the short cross is shifted nearer to one end of the chase; for folios, the long cross is removed entirely, and the short one remains in the middle; and for broadsides, no cross is required. To impose, or arrange and fix the pages in the chase, the compositor makes use of a set of furniture, consisting of slips of wood of different dimensions, somewhat lower than the letters; some of these are placed at the top of the pages, and called head-sticks; others between them, to form the inner margin; and others, in the form of wedges, to the sides and bottoms of the pages. Thus all the pages being placed at their proper distances, and secured from being injured by the chase and furniture placed about them, they are all untied, and fastened together by driving up

small wedges of wood, called quoins, between the slanting side of the foot and the side-sticks and the chase, by means of a piece of hard wood and a mallet; and all being thus bound fast together, so that none of the letters will fall out, it is ready to be committed to the pressmen. In this condition, the work is called a form; and as two of these forms are in most cases required for every sheet, it is necessary the distances between the pages in each form should be placed with such exactness, that the impression of the pages in one form shall fall exactly on the back of the pages of the other; the effecting this is called making register.

As it is impossible but that there must be some mistake in the work, either through the oversight of the compositor, or by the casual transposition of letters in the cases, a sheet is printed off, which is called a proof, and given to the corrector, who, after reading it over, and rectifying it by the copy, making the alterations in the margin, returns it to the compositor to be corrected. The compositor then unlocking the form upon the correcting stone by loosening the quoins or wedges, rectifies the mistakes by picking out the wrong letters with a slender sharp-pointed steel bodkin, and putting others into their places. After this, another proof is made, and corrected as before; and lastly, there is another proof called a revise, which is taken from the form when finally placed on the press, in order to ascertain whether all the mistakes marked in the last proof have been corrected.

The *pressman's* business is to work off the forms thus prepared and corrected by the compositor; in doing which, there are four things required—paper, ink or colouring matter, balls or rollers, and a press.

To prepare the paper for use, it is to be first wetted by dipping several sheets together in water; these are afterwards laid in a heap over each other; and to make them take the water equally, they are pressed close down with a weight at the top.

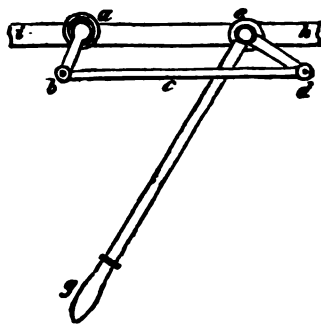
The ink is made of oil and lamp-black; for the manner of preparing which, see *INK*.

The balls, by which the ink was formerly applied on the forms, were a kind of wooden funnels with handles, the cavities of which were filled with wool or hair, as was also a piece of leather or pelt nailed over the cavity, and made extremely soft by soaking in urine, and being well rubbed. One of these the *pressman* took in each hand, and applying one of them to the ink-block, daubed, and worked them together, to distribute the ink equally, and then blacked the form, which was placed on the press, by beating with balls upon the face of the letter. A considerable improvement on this plan has been effected by means of rollers, which are now generally in use. These consist of a cylinder made of a combination of treacle and glue, which runs on an iron rod, affixed to which are two handles. Instead of beating, as in the former case, the cylinder is rolled over the face of the form, by which the ink is applied in a much more even manner, and with a considerable decrease of labour.

The earliest printing presses were the common large wooden screw presses, employed at the present day for compressing paper, cloth, &c. Of course this mode of taking impressions must have been very slow and laborious; and the pressure being applied between the two solid inelastic surfaces, a considerable degree of care must have been exercised to prevent injury to the letters or type of the form. Such presses were, however, used for about 300 years, without any one attempting to improve them. A short time previous to the year 1770 it appears that William Jansen Blaew, a mathematical instrument maker, of Amsterdam, recommended the introduction of a spring, both over the head and under the bed of the press, which, upon trial, proved very satisfactory; he took upon himself an alteration of the working screw, giving it more threads, which is, in effect, a quicker motion; and this, combined with the action of the springs, rendered the impression "sharper," without "hardness." Blaew's presses were found to be so great an improvement upon their precursors, that Luckcombe, in his *History of Printing*, published in 1770, says, "There are two sorts of presses in use, the old and the new fashioned; the old sort, till of late years, were the only presses used in England." Now the "new-fashioned" press of

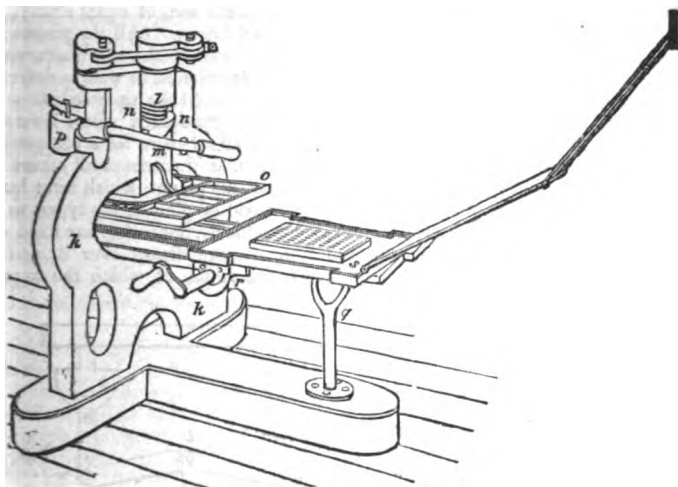
Blaew, though it has become very old-fashioned to modern printers, is too respectable a machine, in our eyes, to be wholly omitted in these pages; and as it differs not in any considerable degree from the wooden-framed presses still in use by many of our printers, we shall here annex a description which will sufficiently apply to them both. It consists of two upright beams, called cheeks, about six feet long, tenoned into a cap above, and, at their lower ends, into a stout square frame, on which it stands. The head of the press is sustained by two iron bolts, that pass through the cap. A screwed nut is fixed in the head, through which the screw works when operated upon by the lever; the lower extremity of this screw is called the spindle, which is a cylindrical piece of steel working in a metallic cup of oil, fixed to an iron plate let into the top of a broad, solid, and thick piece of mahogany, whose surface is brought to a true and smooth plane, and is called the platten. This platten, by pulling the lever, is made to descend and press upon a blanket, which covers the paper laid upon the form of types, and thereby produces an impression. The form is laid upon a broad flat stone, or thick marble slab, which is let into a wooden frame called a coffin; this coffin is fixed upon a carriage, which is made to run upon a horizontal railway under the platten for an impression, and out clear of the same, to take off the printed sheet, and put a blank one in its place. This backward and forward motion of the carriage and form is produced by a strap and pulleys, turned by a winch handle. The paper is adjusted and held down by a folding frame, called the tympan and frisket, which again fold down over the fresh inked type, in a very exact manner, before the form is run in under the platten to receive an impression. By presses of this kind, about 250 impressions are run off in an hour; in light work it is extended to 300 in an hour; and when presses of this kind were used for printing newspapers, the printers managed, by extraordinary efforts and relays of men, to work as many as 500 in the hour.

The principal defect in the common or old fashioned press just described, consists in the effective power of the lever being uniform throughout its range of motion, requiring the pressman to exert his bodily strength to the utmost, in giving it a tug at the end of the pull; at which time only, when the platten is down upon the form, great force becomes necessary. This disadvantage is completely obviated in the improved press invented by the late patriotic Earl Stanhope which machine we purpose describing after having explained the principle upon which its chief excellence depends, namely, the combination of levers, by which the platten is forced down upon the form of types. In the annexed diagram *ab* represents a short lever, which is connected to the top of the screw which carries the platten, the shorter arm of the said lever being the radius of the screw; its longer arm the distance between the centre of the screw to the point *b*. This lever, by means of a connecting rod *c*, acts upon the bent lever *deg*, whose fulcrum is at *e*; and as, by this combination of the lever, the platten acts but through a small space in comparison to the space passed through by the power, it follows that the effect must be very powerful. But it is necessary that this effect should be at a maximum when the platten impinges upon the type, and this object is accomplished by the angular position of the levers; for when the platten is elevated, the lever *eg* is parallel to the line *hi*, and its shorter arm *ed* is nearly perpendicular to the same line, and also the connecting rod *c*; therefore will move the rod *c* with its greatest velocity during the first part of the motion of the lever *eg*; at which time the lever *ab* forms an acute angle with the line *hi*; consequently acts



at a disadvantage in causing the revolution of the screw; but by the time the lever  $eg$  is brought perpendicular to the line  $ks$  (when the platten impinges upon the type) the lever  $ab$  is also perpendicular to the connecting rod  $c$ ; consequently it will then exert its greatest influence in causing the revolution of the screw, and at this time also the power of the workman will be applied at right angles to the lever  $eg$ , therefore will produce the greatest effect precisely at the moment of impact.

The "Stanhope press" is, in other respects, a considerably improved machine. The whole frame is made of one massive iron casting, as represented at  $kk$  in the subjoined cut, which exhibits a perspective view of it. In the upper part of the machine a nut is fixed, into which a stout, well



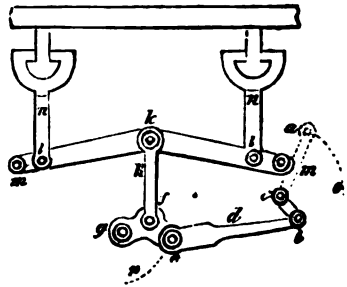
cut screw  $l$  works, having a conical end that operates upon the upper end of a slider  $m$ , which is fitted into a dovetailed groove formed between two vertical bars  $nn$  of the frame. The slider has the platten firmly attached to the lower end of it; and being accurately fitted in the guide bars  $nn$ , the platten rises and falls parallel to itself, when the screw  $l$  is turned. The weight of the platten and slider is counterbalanced by a heavy weight  $p$ , which is suspended from a lever, that acts upon the slider to lift it up, and keep it always bearing against the point of the screw. At  $g$  is a forked support to the railway and carriage. The carriage is moved by a winch or "rounce," with a "spit" and leather straps, which pass round a pulley  $r$ , one strap extending to the back of the carriage to draw it in, and two others pass round the wheel in an opposite direction, to draw it out:  $s$  is the table on which the type is laid. The combination of levers in this machine, it will be observed, is precisely the same as in the preceding diagram, and their action is the same; consequently further description of them is omitted.

The superiority of iron presses over the wooden ones may, in a great measure, be attributed to the extreme accuracy with which the corresponding surfaces of the platten and table are levelled. This is effected by turning them in the lathe, with a slide-rest; and this is performed with such precision that if they do not bite a hair or a thin piece of paper in every part, they are not considered to be finished. The advantage of true workmanship must be apparent in printing such surfaces as those of our large newspapers, and clearly bringing up every letter and dot out of perhaps a hundred thousand or more.

Numerous alterations have been successively made upon the Stanhope press by the manufacturers, who magnify them to the public as being vast improvements, as increasing the productive power of the press in a duplicate and even triplicate ratio; but our mechanical readers will at once perceive the impossibility of the correctness of such statements: that if there be a loss of ten or fifteen per cent. of the power applied to the Stanhope press, arising from friction, &c., no modification whatever of the six mechanical agents can save the whole of such loss. The press may be rendered more convenient and handy, and the minor arrangements and appendages may be also improved; indeed, we doubt not that such ameliorations have been and will continue to be introduced; but they become perfectly insignificant and trifling when compared with the beautiful invention of the patriotic Stanhope. Amongst the ablest manufacturers of the present day of iron presses, we may mention Messrs. Ruthven, Medhurst, Cope, Sherwin, Clymer; there are many others, we doubt not, of equal ability, who have not succeeded in making themselves as well known. All the presses that we have from time to time seen, and especially those of the manufacturers we have named, possess some peculiar points of excellence as well as defects in their mechanism, to describe and discuss which would take up much time and space. In justice, however, to the two first-named gentlemen, whose inventions possess great originality and simplicity, we must afford room for a compendious notice of the peculiar contrivances which distinguish them from all others.

In 1813 Mr. Ruthven, of Edinburgh, took out his patent, which term having expired, the invention is public property. Instead of placing the types, as was the case in all previous inventions, upon a movable carriage, they are fixed upon a stationary table, and the platten and tympan are drawn over it, and the impression is effected by a system of levers, the action of which the annexed diagram will serve to explain.

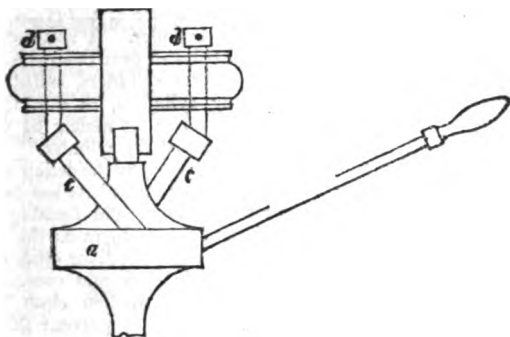
$acb$  is an angular lever, whose longer arm  $ac$  is in the form of a winch, to which the workman applies his power; while the shorter arm  $cb$  acts upon the extremity of the connecting rod  $d$ , by which its efficacy is transmitted to the point  $e$  of the lever  $ef$ , whose fulcrum is at  $g$ ; this lever is connected by the rod  $h$  to the extremities of the levers  $klm$ , whose fulcra are  $mm$ . The rods  $nn$  are connected with the levers  $klm$  at  $ll$ , while their upper ends act upon the support



of the platten by means of a species of hooks. Now if the lever or winch  $ac$  be turned in the direction of the dotted line  $aa$ , the shorter arm  $cb$  will push the rod  $d$  in the direction  $be$ ; consequently the point  $e$  of the lever  $efg$  will move in the direction of the dotted line  $ep$ ; and as the point  $f$  will describe a similar arch, the rod  $h$  will depress the ends  $k$  of the levers  $klm$ ; therefore the rods  $nn$  will be drawn down, bringing with them the platten. The same regulation with regard to the angular positions of the levers is observed in this beautiful arrangement as in the Stanhope, so that their greatest efficacy is exerted at the moment of impact.

Mr. Medhurst's press, except in the mechanism by which the power is communicated to the platten, resembles those in general use; but in that respect it forms a very remarkable exception; no screw is used: but the spindle to which the platten is made fast is swelled out at its upper end into a broad stout collar, as shown at  $a$  in the following cut, into which the lever or handle  $bo$  the press is inserted. At equal distances apart on the upper side of this circular collar are turned out of the solid two steps or cups, which receive the ends  $o$  two inclined bolts  $cc$ , which bolts are supported at their upper ends by the points of two screw-bolts  $dd$ , that pass through the head  $e$ , and enter sockets

made in the heads of *cc*. When the platten is up, the rods *cc* lean in the inclined position, as shown; but when the spindle is turned a quarter of a revo-



lution, the bolts *cc* take a vertical position, and as the head *c* is immovable, the collar *a* on the spindle is forced down, and with it the platten to which it is attached.

Prior to the introduction of printing machines, the press department was one of great labour, whenever extraordinary expedition was required. It was particularly the case with newspapers, of which, with the utmost exertions, scarcely ever more than 750 copies could be obtained in an hour: the consequence was, that in newspaper offices where the circulation was extensive, it was found necessary, in order to get the paper published in time, to compose two or more copies; so that, by going to press at the same time, the demands of the public might be complied with, thus occasioning an enormous increase of expenditure both in the compositors' and press department. In a newspaper circulating 7 or 8000 copies, this expense amounted annually to at least 2000*l.*, all of which has been saved by the introduction of machines.

In the 3d vol. of the *Quarterly Journal of Science* (new series) is inserted a communication "on the recent improvements in the art of printing," by Mr. Cowper, a gentleman of extensive information upon every thing relating to the subject, who has invented many important improvements in the mechanism and process of the art, both individually, and in conjunction with his partner, Mr. Applegath, and who is therefore eminently qualified to give a correct statement of the facts, which we shall subjoin, slightly abbreviated from the original. The little diagrams that are inserted in the body of the text serve to explain, in a very clear and concise manner, the leading principle or arrangements of the successive inventions described, respecting which it is also necessary to observe, that—

- |   |                                      |
|---|--------------------------------------|
| The black parts in every figure represent | the inking apparatus.                |
| The diagonal lines                        | " " the paper cylinders.             |
| The perpendicular lines                   | " " the types or plates.             |
| The arrows                                | " " the track of the sheet of paper. |

It was in the year 1790 that Mr. William Nicholson took out a patent for certain improvements in printing; and, on reading his specification, every one must be struck with the extent of his ideas on the subject: to him belongs, beyond doubt, the honour of the first *suggestion* of printing by means of cylinders; the following are his own words, divested of legal redundancies:—

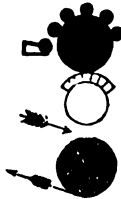
"In the first place, I not only avail myself of the usual methods of making type, but I do likewise make and arrange them in a new way, viz. by rendering the tail of the letter gradually smaller; such letter (he says) may be



imposed on a cylindrical surface; the disposition of types, plates, and blocks, upon a cylinder, are parts of my invention.

"In the second place, I apply the ink upon the surface of the types, plates, &c. by causing the surface of a cylinder, smeared with colouring matter, to roll over, or successively apply itself to the surface of the types, &c., or else I cause the types to apply themselves to the cylinder. It is absolutely necessary that the colouring matter be evenly distributed over this cylinder, and for this purpose I apply two, three, or more smaller cylinders, called distributing rollers, longitudinally against the colouring cylinders, so that they may be turned by the motion of the latter; if this colouring matter be very thin, I apply an even blunt edge of metal or wood against the cylinder.

"In the third place, I perform all my impressions by the action of a cylinder, or cylindrical surface; that is, I cause the paper to pass between two cylinders, one of which has the form of types attached to it, and forming part of its surface, and the other is faced with cloth, and serves to press the paper so as to take off an impression of the colour previously applied; or otherwise, I cause the form of types, previously coloured, to pass in close and successive contact with the paper wrapped round a cylinder with woollen cloth." He also described a method of raising the paper cylinder, to prevent the type from soiling the cloth.



*Nicholson's arrangement for arched types.*

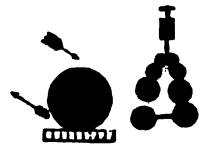


*Nicholson's arrangement for common types.*

These words specify the principal parts of modern printing machines; and had Mr. Nicholson paid the same attention to any one part of his invention which he fruitlessly devoted to attempting to fix types on a cylinder, or had he known how to curve stereotype plates, he would, in all probability, have been the first *maker* of a printing machine, instead of merely suggesting the principles on which they might be constructed.

The first working printing machine was the invention of Mr. T. Koenig, a native of Saxony; he submitted his plans to Mr. T. Bensley, the celebrated printer, and to Mr. R. Taylor, the scientific editor of the *Philosophical Magazine*. These gentlemen liberally encouraged his exertions, and in 1811 he took out a patent for improvements in the common press, which, however, produced no favourable result. He then turned his attention to the use of a cylinder, in order to obtain the impression, and two machines were erected for printing the *Times* newspaper, the reader of which was told, on the 28th of November, 1814, that he held in his hand a newspaper printed by machinery, and by the power of steam.

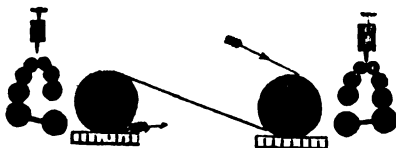
In these machines the type was made to pass under the cylinder, on which was wrapped the sheet of paper, the paper being firmly held to the cylinder by means of tapes; the ink was placed in a cylindrical box, from which it was forced by a powerful screw, depressing a tightly-fitted piston; thence it fell between two iron rollers: below these were placed a number of other rollers, two of which had, in addition to their rotatory motion, an end motion, that is, a motion in the direction of their length; the whole system of rollers terminated



*Koenig's single, for one side of the sheet.*

in two, which applied the ink to the types. In order to obtain a great number of impressions from the same form, a paper cylinder (i. e. a cylinder in which the paper is wrapped) was placed on each side of the inking apparatus, the form passing under both. The machine produced 1100 impressions per hour; subsequent improvements raised them to 1800 per hour.

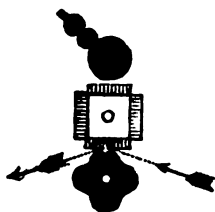
The next step was the invention of a machine (also by Mr. Koenig) for printing both sides of the sheet: it resembled two single machines, placed with their cylinders towards each other, at a distance of two or three feet. The sheet was conveyed from one paper cylinder to the other by means of tapes; the track of the sheet exactly resembled the letter S, if laid horizontally, thus, *∞*. In the course of this track the sheet was turned over. At the first paper



*Koenig's Double Machine, for printing both sides of the Sheet.*

cylinder it received the impression from the first form, and at the second paper cylinder it received the impression from the second form; the machine printed 750 sheets, on both sides, per hour. This machine was erected for Mr. T. Bensley, and was the only one Mr. Koenig made for printing on both sides the sheet: this was in 1815.

About this time Messrs. Donkin and Bacon were also contriving a printing machine; having in 1813 obtained a patent for a machine in which the types were placed upon a revolving prism; the ink was applied by a roller, which rose and fell with the irregularities of the prism; and the sheet was wrapped on another prism, so formed as to meet the irregularities of the type prism. One of these machines was erected for the university of Cambridge, and was a beautiful specimen of ingenuity and workmanship; it was, however, too complicated, and the inking was defective, which prevented its success. Nevertheless, a great point was attained; for in this machine were first introduced inking-rollers, covered with a composition of treacle and glue; in Koenig's machine the rollers were covered with leather, which never answered the purpose well.



*Donkin and Bacon's Machine for Type.*

In 1815 Mr. Cowper obtained a patent for curving stereotype plates for the purpose of fixing them on a cylinder. Several of these machines, capable of printing 1000 sheets per hour on both sides, are at work at the present day; and twelve machines on this principle were made for the Bank of England a short time previous to the issue of gold.



*Cowper's single, for curved Stereotype.*



*Cowper's double, for both sides of sheet.*

It is curious to observe that the same object seems to have occupied the attention of Nicholson, Donkin and Bacon, and Mr. Cowper, viz. the revolution



of the form of types. Nicholson sought to do this by a new kind of type, shaped like the stones of an arch. Donkin and Bacon sought to do this by fixing types on a revolving prism; and at last it was completely effected by the curving of a stereotype plate by Mr. Cowper.

In these machines two paper cylinders are placed side by side, and against each of them is placed a cylinder for holding the plates; each of these four cylinders is about two feet diameter; on the surface of the plate cylinder are placed four or five inking-rollers, about three inches diameter; they are kept in their position by a frame at each end of the plate cylinder, the spindles of the rollers lying in the notches on the frame, thus allowing perfect freedom of motion, and requiring no adjustment. The frame which supports the inking-rollers, called the waving-frame, is attached by hinges to the general frame of the machine; and the edge of the plate cylinder is indented, and rubs against the waving-frame, causing it to wave or vibrate to and fro, and, consequently, to carry the inking-rollers with it, thus giving them a motion in the direction of their length, called the end motion. These rollers distribute the ink upon three-fourths of the surface of the plate cylinder, the other quarter being occupied by the curved stereotype plates. The ink is held in a trough; it stands parallel to the plate cylinder, and is formed by a metal roller revolving against the edge of a plate of iron; in its revolution it becomes covered with a thin film of ink; this is conveyed to the plate cylinder by an inking-roller vibrating between both. On the plate cylinder the ink becomes distributed, as before described, and as the plates pass under the inking-rollers they become charged with colour: as the cylinder continues to revolve, the plates come in contact with a sheet of paper in the first paper cylinder, whence it is carried, by means of tapes, to the second paper cylinder, where it receives an impression on its opposite side from the plates on the second plate cylinder, and thus the sheet is perfected. These machines are only applicable to stereotype plates, but they formed the foundation of the future success of Applegath and Cowper's printing machinery, by showing the best method of furnishing, distributing, and applying the ink.

In order to apply this method to a machine capable of printing from type, it was only necessary to do the same thing in an extended flat surface or table, which had been done on an extended cylindrical surface; accordingly Mr. Cowper constructed a machine for printing both sides of the sheet from type, securing by patent the inking apparatus, and the mode of conveying the sheet from one paper cylinder to the other by means of drums and tapes.



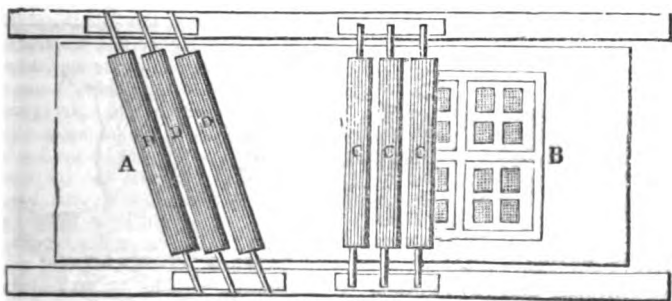
*Applegath and Cowper's Single Machine.*



*Applegath and Cowper's Double Machine.*

Mr. A. Applegath, who was a joint proprietor with Mr. Cowper in these patents, obtained patents for several improvements. Mr. Cowper had given the end motion to the distributing rollers by moving the frame to and fro in which they were placed. Mr. Applegath suggested the placing of these rollers in a diagonal position across the table, thereby producing their end motion in a simpler manner,—a plan of which we subjoin. A is the inking table or flat

surface, on which the ink is spread and distributed; B is the form of types; CCC are the rollers for communicating the ink to the types; DDD are the distributing rollers placed diagonally across the table, their pivots resting in slots in the carriages. The table is made to slide backward and forward, causing by that motion the rollers to revolve, which are nicely adjusted in contact with the table, so as to press evenly on the surface of it, those in the oblique position



Applegath's Patent Inking-Table.

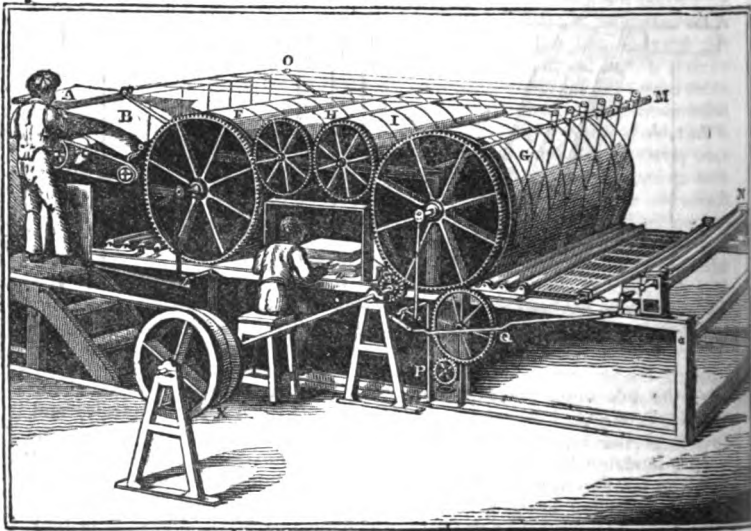
causing the ink upon the surface to be *spread* out very evenly, so that the rollers CCC, which follow in action, become charged very uniformly, and deliver it to the type in like manner. The diagonal rollers must have an admirable tendency to spread out the ink in a smooth stratum, by the sliding of the table in a different direction to the lines of revolution; but there must be considerable friction at their axes by the constant tendency of the table to thrust the rollers sideways or endways, which must be provided against, or they will soon wear untrue. He also contrived a method of applying two feeders to the same printing cylinder; these latter inventions are more adapted to newspaper than to book-printing. Numerous machines have been constructed upon the joint inventions of Messrs. Applegath and Cowper, which are modified in a great number of ways for the various purposes of printing books, bank-notes, newspapers, &c.; they have, in fact, superseded Mr. Koenig's machines in the office of Mr. Bensley (who was the principal proprietor of Koenig's patent), and also in the office of the *Times*, as was announced in that journal. No less than forty wheels were removed from Koenig's machines when Mr. Bensley adopted the improvements of Messrs. Cowper and Applegath. Having, on the first trial of their machines, discovered the superiority of the inking-roller and table over the common balls, they immediately applied them to the common press, and with complete success; the invention, however, was immediately infringed throughout the kingdom, and copied in France, Germany, and America; and it would have been as fruitless to have attempted to stop the infringement of the patent as it was found in the case of the kaleidoscope. This invention has raised the quality of printing generally. In almost any old book will be perceived groups of words very dark, and other groups very light; these are technically called "monks and friars," which have been reformed altogether. The principal object in a newspaper machine is to obtain a great number of impressions from the *same* form, or one side of the sheet, and not from *two* forms, or both sides of the sheet, as in books.



In the *Times* machine, which was constructed on the joint invention of Messrs. Applegath and Cowper, the form passes under four printing cylinders,

which are fed with sheets of paper by four lads, and, after the sheets are printed, they pass into the hands of four other lads; by this contrivance 4000 sheets per hour are printed on one side.

The annexed engraving affords a general or perspective view of one of Messrs. Cowper and Applegath's double machines, constructed on the prin-



ciple of the diagram on page 346. A boy is represented as standing upon a platform, with a pile of paper A on a table on his left hand, from which he has taken a sheet of paper B, and is applying it to the machine. It first goes under the cylinder F, and is there printed on one side, it is then conducted over the intermediate cylinders H I, on to the cylinder G, passing round this, and underneath; the sheet of paper is thereby turned with its opposite side against the type, and receives the second or finishing impression, and is then conducted to the top of the pile of printed sheets, where a boy at Z is shown sitting on a stool, and receiving the sheets as they are presented, and laying them square on the pile before him. The separate forms of types designed to print both sides of the sheet, are placed at the requisite distance asunder, upon one long bed mounted on a carriage, which is moved backwards and forwards upon a railway, constructed to guide the carriage, with great accuracy, into contact with the cylinders F and G, to produce the impression. The reciprocating motion of the carriage is effected by a pinion fixed upon the end of a vertical spindle, taking into the teeth of an endless rack, which is connected by a system of levers with the type carriage, in such a manner, that when the pinion is turned round, it engages, at alternate periods, in the teeth formed on the opposite sides of the rack, and consequently on the opposite circumference of the pinion; thereby a continuous motion of the pinion communicates a reciprocating motion to the rack and carriage. The vertical spindle is turned by a couple of bevelled wheels, from the pinion P, which receives its motion by an intermediate wheel Q from the toothed wheel upon the end of the main cylinder G. An inking apparatus is situated at each end of the machine. At N one of these is brought into view; it consists of a cylindrical metal roller, which has a slow rotatory motion, communicated to it by a catgut band passing round a small pulley upon the end of the axis of the main

cylinder G. The roller at N is adapted to carry down a thin film of ink upon its circumference, by turning in contact with a mass of ink disposed upon a horizontal plate of metal, the edge of which plate is ground straight, and the distance between the two surfaces is adjusted by screws. Upon an axis turning at P, is mounted a composition roller, connected by cranked levers with a small eccentric circle fixed upon the end of the axis of the cylinder *g*, causing it to move round the axis P, and remain for a short period in contact with the face of the ink-roller N, thereby receiving a portion of ink upon its surface: it then descends and rests with its whole weight upon the surface of the table, which is affixed to the end of the type carriage, the reciprocating motion of which causes the ink-table to receive ink upon its surface from the elastic roller before mentioned. In this situation, when the type-carriage returns, the surface of the table is made to pass under three elastic rollers; these rollers are mounted upon pivots in a frame, in such manner that they have liberty to move somewhat up and down, in order that the rollers themselves may bear severally upon the surface of the table; and to equalize the ink perfectly over the table, an end motion is given to the rollers by means of inclined planes, against which they come into contact; and by the further motion of the type-carriage, the ink-table is caused to pass under four other small elastic rollers, which in like manner bear with their weight upon the surface of the table, and thereby take up the ink upon their circumferences, which they impart to the types as the form travels backwards and forwards under them, thus touching every type eight times. Whilst this operation of inking the types is going on at one end of the machine, the printing process is performed at the other end on one of the sides of the sheet from the types last inked, and *vice versâ*.

The improvements in printing machinery, patented by Mr. Wayte, a printer, of Mount Pleasant, London, in 1829, deserve notice on account of their originality and simplicity. In his specification is described a printing machine, or press, having two tables with a form on each, the one to press the first side of the sheet, and the other to perfect it, or print the second side. These two tables are placed on a vibrating frame, which is actuated by a crank, and brings them alternately under a pendent-platten, which is brought down upon them through the instrumentality of a crank, to give the impression. The frame which supports the form-tables consists of a parallelogram jointed at the angles, and therefore the horizontal position of the forms is preserved, both when they are elevated to the platten to receive the impression, and depressed to the rollers to receive a supply of ink. There is an inking apparatus for each form, placed at opposite ends of the machine: it consists of a long trough, and a doctor and supply-roller, of the usual description; with distributing-rollers, which traverse the forms, and are kept in their places by guides, with long vertical slits to receive their axes. When either of the forms is depressed, its distributing-rollers are carried to the ink-trough to receive ink from the supply-roller, which they transfer to the form by passing over its surface as it is elevated.

The paper to be printed is supplied to the machine from a feeding-board, through the medium of an endless web, passing over rollers, connected by bands or chains to the main shaft, which communicates, simultaneously, to all parts of the machine. The sheets of paper being placed on the feeding-board, a boy pushes them forward singly, when they are successively caught by the rollers and endless web, by being pressed down upon them through the medium of a projecting lever, operated upon at stated times by the motion of the machinery. When the sheet of paper is brought between the form and the platten, its motion, as well as the motion of the form, is stopped while the impression is communicated to it. This stoppage of motion is effected without interfering with the motion of the main shaft, and other parts of the machinery, by removing the teeth from a portion of the circumference of the spur-wheel, which communicates motion to the web-rollers. After the first impression has been given to the sheet, it is carried about another roller, which turns its reverse side towards the platten, while the second or perfecting form is brought, by a vibration of the frame-work, under the paper to print the second side, or to give it

the perfecting impression, which is effected while the motion of the web-roller is stopped as before.

The platten is suspended over the centre of the press, and guided perpendicularly down by strong frame-work, and the pressure is produced by a vertical rod, connected with the platten at its upper end, and with a revolving crank at its lower end; a lever with a counterpoise is also connected with the lower end of the vertical rod, which compensates for the weight of the rod and platten, while the two form-tables balance each other on the vibrating frame; and thus jarring irregularities in the motion of the machinery is prevented.

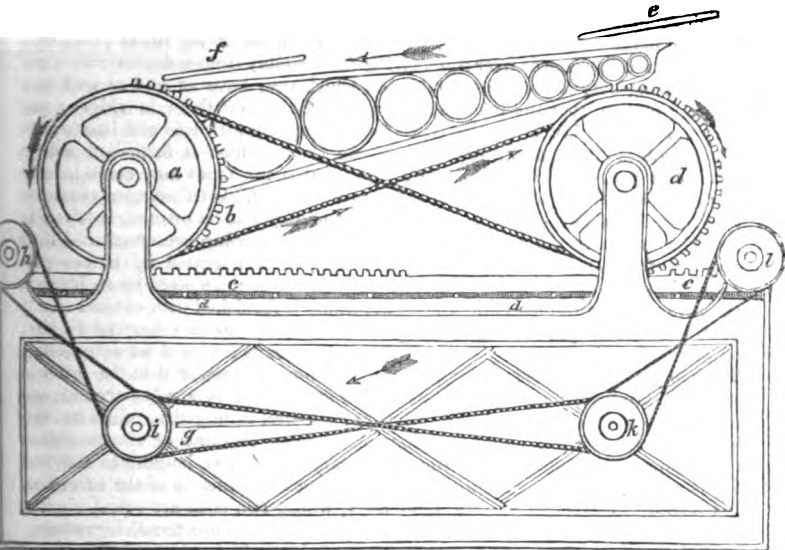
The second improvement consists of a printing press, or machine, with but one form-table, which is placed upon a frame, and made to vibrate between two plattens, placed in oblique positions, where impressions are given by each with such rapidity, that two or more feeding-boards, with the requisite web-rollers, are required to supply it with paper. This is a single printing machine, and there the sheet has to pass through it twice before the printing is completed. It differs, however, materially from the common printing machines; it having two plattens, and a form-table placed between them on a vibrating frame, instead of running forwards and backwards on wheels, as is the case with the printing machines employed at the *Times'* office, and other machines made by Applegath and Cowper.

Mr. Wayte's third improvement consists in a new arrangement of inking-rollers, by which he is enabled to diminish their number, and to effect a saving in the ink, by conducting the supply to such places only of the distributing-rollers as come in contact with the types: this is effected by causing the inking-rollers to pass over distributing blocks, which are made to correspond with the types in the form, and supplied with ink by a transferring roller; by this means the ink is supplied only to such parts of the rollers as come in contact with the types. This inking apparatus is equally applicable to the printing machines invented by Mr. Wayte, and to those of the usual construction.

Mr. David Napier, of Fitzroy Square, London, a manufacturer of printing machinery, of great ability and experience, specified a patent in 1831, granted to him for "certain improvements in printing and pressing machinery, with a method of economizing power, which is also applicable to other purposes." There are four inventions contained in this patent, all having reference to the printing business, and calculated to increase its facilities; we therefore subjoin a brief account of them.

The *first* is a printing machine, of the kind called a perfecting, or that which prints both sides of the sheet before it is delivered from the machine. There are two forms of type placed on the same traversing stage, so far apart that the distance between them shall be equal to the length of one of the forms. The sheet of paper to be printed is conveyed to the forms by endless felts and guide rollers, in the manner usually adopted in the printing machines manufactured by Cowper and others. On the axes of the two rollers, which give the pressure to the paper while on the type form, are fixed two wheels, with teeth extending only half round, each of which takes into racks fixed on the side of the form stage. The diameter of these wheels is equal, and they are made exactly to correspond with the diameter of the rollers with which they move; they are connected together, and made to turn in different directions by means of a band passing over equal pulleys on each, and being so adjusted with respect to each other, that the toothed half of the one shall be upwards while the toothed part of the other is downwards; and thus they will take into their respective racks, and cause the form to traverse backwards and forwards alternately. This arrangement will be better understood by inspecting the opposite diagram. *a a* represents the two cylinders which give the impression, with spur-wheel teeth on half the circumferences, as shown at *b b*. These teeth take into the racks *c c*, which being connected with the form stage *d d*, communicating to it reciprocating motion. The sheets of paper to be printed are receiving alternately from the feeding-tables at *e f*, and receive the first impression as they pass under the cylinder *a*; whence following the course pointed out by the arrows, they pass around and receive the second, or completing impression, in returning

under the cylinder *a*, and are finally delivered on the receiving board *g*. The endless felts, tapes, and guide rollers, by which the sheets of paper are conducted, are not shown in the drawing, as they do not differ materially from those usually adopted for this purpose. *k i k* and *l* represent a series of pulleys, by which the inking apparatus is put into operation.



Mr. Napier's *second* improvement applies to the inking part of the printing machines. It consists of a series of rods, jointed and connected together in the manner of the system of rods which constitute the parallel motion of a steam engine; and these are applied to produce an alternating rectilinear motion to a frame carrying a set of inking rollers. This inking apparatus is suspended from a frame extending over the type forms; and it is equally applicable to printing machines on a large or small scale, whether actuated by steam or any other first mover.

The *third* improvement consists of a pair of pressure rollers for the purpose of pressing the sheets of paper after they have been printed, instead of using an hydraulic or screw-press, to give to printed paper the required degree of smoothness. The construction of Mr. Napier's rolling-press does not materially differ from the rolling-press applied to bookbinding a few years ago by Mr. William Burn, of Kirby-street, and which has now nearly superseded (in London at least) the laborious and uncertain processes of beating, formerly practised by bookbinders. The rollers of the press patented by Mr. Napier are placed horizontally, with respect to each other, while those of the press introduced by Mr. Burn occupy a vertical position.

The *fourth* invention described in this specification consists of a plan for equalizing the intermittent power of an alternating action, when applied to produce continuous rotatory motion. The power is to be applied by a lever similar to a pump-handle, which turns freely on a fixed axis or fulcrum; at one extremity near this axis is a click or pall, which takes into the teeth of a small ratchet-wheel attached to the axis of a box containing a coiled spring, with one end fixed to the axis, and the other to the circumference of the containing box; to this box is fixed a toothed wheel, which takes into the teeth of a pinion, or on the axis or shaft, to be put into rotatory motion; and thus the alternating action of the lever, which is only employed in winding up the

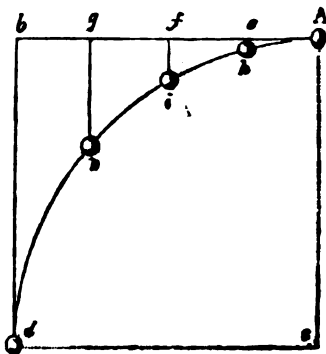
spring, is rendered efficacious in giving continuous rotatory motion to a pinion or spur-wheel, and hence to any system of machinery to which it may be applied.

A patent "for improvements in printing machines" was granted to R. Winch, of Shoe Lane, London, in 1831, which appear to us to be of importance, as they effect a considerable diminution of the quality of alternating matter, by which economy of power, and a saving of repairs are likely to result. The type form is made to rest stationary, while the inking-rollers are made to traverse forwards and backwards over it, receiving their supply from a ductor roller, and then passing over a distributing table, on which they have an end as well as a rotatory motion, that the ink may not accumulate upon them in ridges; and they deliver the ink upon the types both in passing forwards and backwards. The frisket is attached to a slight traversing frame, which is furnished with a series of tapes, on which the paper is laid, so that the tapes may come in contact only with the spaces between the pages. This frisket frame moves upon an iron railway, and having received a sheet of paper to be printed, it is run in till it comes over the types and under the platten, being preserved at a little distance from the types by spring supports; it is liberated by pieces projecting from the platten, and yields to the pressure of the platten when brought down to give the impression. The frisket frame is furnished with conical steady pins, with small apertures in their tops for the reception of other steady pins, for regulating the register when the sheet of paper is reversed for completing. The motions of the various parts of this machine are produced in the order in which they are required through the medium of various levers, wheels, cams, and pulleys, possessing separately little novelty, but well arranged to effect in combination the different and somewhat complicated motions of the machine: these, however, we have not deemed necessary to detail at length, as different forms of them may be used without abandoning the principle of the invention.

**PRISM**, in Geometry, is a solid body, whose two ends are equal, similar, and parallel planes; and its sides connecting those ends are parallelograms.

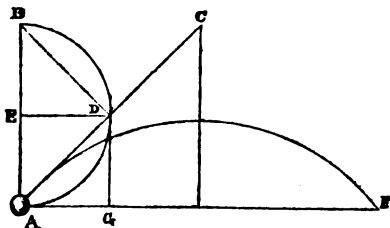
**PRISM**, in Optics, is a triangular prism of glass, which separates the rays of light passing through it in consequence of the different degrees of refrangibility that take place in different parts of the same ray.

**PROJECTILES.** The laws of projectiles, or bodies projected by any impulsive force into the atmosphere, are identical with those by which the motions of bodies falling perpendicularly in free space are governed; so that when their relation is understood, a knowledge of the one necessarily leads to an acquaintance with the other. It is well known that if a body be under the influence of a single impulsive force, as a blow with a hammer, or the explosive force of gunpowder, its velocity will be uniform; that is, it will pass over equal space in equal portions of time. It is also well known that a body falling freely in space falls with an accelerated velocity, so that the spaces fallen through in successive equal portions of time, continually increase. Now, if we apply these facts to the case of a body projected through the air, we shall find the same laws to be preserved throughout. In the diagram, on the following page, if we suppose a body *a* projected horizontally, that is, in the direction *ab*, it would, if not acted upon by the force of gravity, proceed to describe the equal spaces *ae*, *ef*, *fg*, and *gb*, in equal successive intervals of time. On the other hand, if we suppose the body simply to fall by its own weight, it will fall through spaces equal to *eh*, *fi*, *gk*, and *bd*, in exactly the same space of time which it would take to pass over the former spaces. Let us now suppose the two



motions to be simultaneous, then the body descending as much as  $eh$  while passing from  $a$  to  $e$ , would be found at  $h$ ; in passing from  $ef$  it would descend as far as  $i$ , and so on till it reached the point  $d$ . In this process it will be seen that neither the horizontal nor the vertical velocity is at all affected by the action of the other. From the spaces  $eh, fi, gk$ , and  $bd$ , being as the squares of the distances  $ae, af, ag, ab$  it is shown that the curve  $ahikd$  is a *parabola*, which, in all cases, is the kind of curve described by bodies under the influence of two forces, such as we have been describing. The altitude to which any projectile would ascend, and the distance it would range in a vacuum

are easily ascertained. Let  $AB$  be the height through which the projectile would ascend by the force impressed upon it at its outset, and  $AC$  the direction in which it is projected. Describe a semi-circle  $BDA$  upon the line  $AB$ , and where the direction  $AC$  cuts the circumference, draw the line  $ED$  perpendicular to  $AB$ , then will  $ED$  be one-fourth of the horizontal range, and  $EA$  the altitude to which it will ascend.



If the horizontal range and the projectile velocity be given, the direction, so as to hit a given object, may be thus found. Take  $AG$  equal to one-fourth of  $AF$ , and draw  $GD$  perpendicularly to meet the circle, then will  $AD$  be the direction in which the projectile must be cast to strike an object at  $F$ . If the range  $AF$  and the direction  $AC$  are known, then the velocity that must be given is found by taking  $AG$ , equal to one-fourth of  $AF$ , raising the perpendicular  $GD$ , and drawing  $AB$  perpendicular to  $AF$ , till it meets  $DB$ , drawn perpendicular to  $AC$ ; then will  $AB$  be the altitude due to the projectile velocity. Since there may be two perpendiculars on the semicircle of equal length, there will be two different elevations that will produce the same range; and since the radius is the longest line that can be drawn in this way, the greatest range will be when the angle of elevation of the projecting machine is  $45^\circ$ , or half a right angle, and in this case it will be just double the altitude due to the initial velocity. The time which the body would occupy in its flight is always equal to the time a body would take in falling through four times the height of the parabola which it describes.

All the foregoing remarks apply only to the motion of bodies in a vacuum, and would therefore require great correction before they are applied in practice, except in particular cases. When used to regulate the discharge of large shells, or other bodies whose initial velocities do not exceed three or four hundred feet, they may be considered as tolerably accurate. But in cases of great projectile velocities, the theory is quite inadequate without several data drawn from many good experiments; for so great is the effect of the resistance of the air to projectiles of considerable velocity, that some, which, in the air, range only between two and three miles at the most, would, in vacuo, range about ten times as far, or between twenty and thirty miles.

**PROTOXIDE.** A term used in chemistry to denote the minimum of oxidisement.

**PROTRACTOR.** An instrument used for protracting, or laying down on paper the angles of any figure. The protractor is commonly a small semicircle of brass, nicely divided it into 180 degrees; the ends of the arch are connected by a straight rule, the outside edge of which is the diameter of the circle. It serves not only to draw angles on a plane, but likewise to examine those laid down. For this purpose, there is a small point in the centre or middle of the edge of the straight rule, which point, being placed upon the vertex of the angle and the edge of the rule, so as to coincide with one of the sides of the angle, the other line of the angle then cuts through the number of degrees marked on



the protractor, which is its true measurement. Protractors are now usually made in the form of a parallelogram, and graduated with diverging lines from a central point upon one edge, to the opposite edge where the degrees are marked.

Mr. Twitchell's improved protractor is stated in the *Franklin Journal* to consist of a circle, marked with the lines of sines, tangents, secants, semi-tangents, and chords. To the centre of the circle is annexed a scale of the shape of half a cross, agreeing with the line of chords on the circle, and marked on each limb with the line of equal parts. The cross limb of this scale consists of two parts; to one of which is annexed a semicircle, marked with the line of chords, the other part turning on its centre, and agreeing with the line of chords on the semicircle, serving both as a protractor and scale. To the centre of the whole circle is annexed a small limb, agreeing with the line of chords on the circle, and extending over the scale, and serving as a secant to the circle. This scale exhibits the use of chords, sines, secants, and tangents, and the mode of applying them to angles, giving the sides and chords of any triangle, and also its sine, tangent, and secant; likewise latitude, departure, course, and distance. For drafting, this scale is particularly useful; for in plotting, nothing more is required, than to turn the scale to the course, and mark the distance. The correctness of the description thus given of the instrument by Mr. Twitchell, is corroborated by the valuable testimony of the learned editor of the *Journal*, Dr. Jones, who remarks in a note, that the instrument, "in addition to the purposes indicated," will be found "particularly useful in teaching trigonometry, as it renders the relationship of the angles objects of sense."

**PUMICE-STONE.** A light grey-coloured substance, of a fibrous spongy texture, supposed to be formed from felspar, in volcanic fires, and thence ejected in a state of fusion.

**PUMPS.** Machines for raising water and other fluids; usually consisting of a tube or tubes, in which valves and pistons, or buckets, are made to operate, to produce the effect. Engines differently constructed, and particularly those upon a larger scale than ordinary pumps, are generally termed **HYDRAULIC MACHINES**, which we have already treated of under that head. The ordinary definition of pump is, "a machine in which water is raised by the pressure of the atmosphere," which accords with the prevalent but erroneous notion, that the atmosphere does of itself raise water to a height of thirty feet; notwithstanding it is known to those who have considered the subject, that it does not, in fact, contribute in the slightest degree to raise it at all; and that the same force is requisite to raise a pound of water a given height, as to raise a pound of lead, or of any other substance, through the same space. Of the evident truth of this fact, the reader, if a novice, will be satisfied upon reading our article on hydraulics or hydrodynamics, and by attending to the following description of a

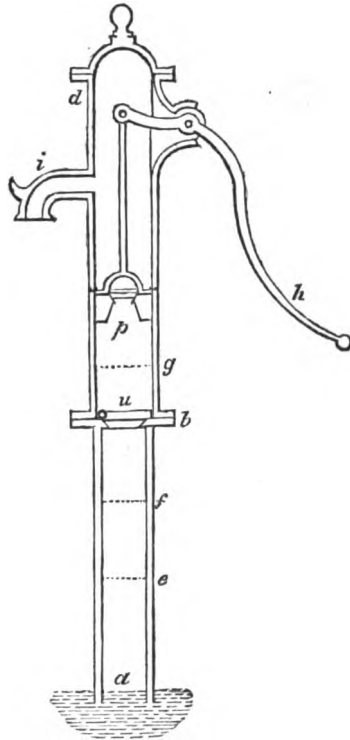
*Common, or "suction" pump.*—This pump consists of two hollow cylinders,  $a b$  and  $b d$ , placed one under the other, and communicating by a valve  $u$ , which opens upwards. The cylinder  $a b$  is called the suction pipe, and has its lower end immersed in the well, or reservoir, from which the water is to be raised. In the barrel  $b d$  a bucket or piston  $p$  is moved, having a valve in it which opens upwards; this piston should move air-tight in the cylinder. At  $i$  is a spout for the discharge of the water. Supposing the bucket to be at the bottom of the cylinder  $b d$ , and in close contact with the valve  $u$ ; upon elevating it, the piston-rod is kept closed by the atmospheric pressure, and if the valve  $u$  were not permitted to rise, a vacuum would be caused between it and the piston, the elevation of which would then require a force equal to about 15 lbs. multiplied by as many square inches as are in the section of the piston. But the moment the piston begins to ascend, the elasticity of the air in the suction-pipe beneath opens the valve  $u$ , and the air rushing through, balances part of the pressure on the piston. Now, if the water at  $a$  were not permitted to rise, the air between the piston and the surface  $a$  would be rarefied by the ascent of the piston. It would, therefore, press against the lower surface of the water with a force less than the atmosphere; but the

entire force of the atmosphere presses on the surface of the water in the well; and the diminished elasticity of the air in the suction-pipe not being a counterpoise for this, the water is necessarily pressed up into that pipe. The height to which the water will rise in the suction pump will be proportioned to the length of the stroke of the piston  $p$ ; but let us suppose it to have risen to the level of the dotted line  $e$ , there is then a compound column of air and water pressing on the level  $a$ ; namely, the column of water  $ae$  and the elastic force of the air in  $eb$ . These two together balance the atmospheric pressure on the external surface of the water in the well. It consequently follows, that the air in  $eb$  must be rarefied, since its elasticity falls short of the atmospheric pressure by the pressure of the column of water  $ae$ . As a column of water about thirty-three feet in height balances the atmosphere, it follows that the elasticity of the air in  $eb$  is equal to the pressure of a column of water whose height is equal to the excess of thirty-three feet above  $be$ .

At the next stroke of the piston, a further quantity of air is extracted, and the diminished elasticity under the piston causes the water to ascend to the level  $f$ , and the succeeding strokes raise it to the levels  $b$  and  $g$ . Hitherto, this machine has only operated as an air pump, but at the next descent of the piston, the water at  $g$  passes through the piston-valve, which closes and prevents its return; and upon the next ascent of the piston, the pressure of the atmosphere forces more water through the valve  $u$ . The succeeding descents and ascents are attended with like effects, until the water has reached to a level with the spout  $i$ , where it is discharged at every succeeding stroke afterwards. The force necessary to lift the piston is the weight of a column of water, whose height is that of the level of the water in the well, and whose base is equal to the section of the piston. This force, therefore, from the commencement of the process, continually increases, until the level of the water rises to the discharging spout  $i$ , and thenceforward remains uniform.

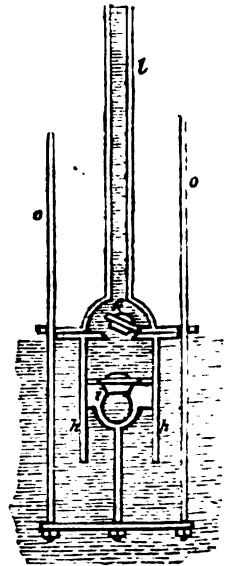
As the common, or sucking pump, operates by the production of a vacuum within the working-barrel, by which the external atmospheric pressure is called into action, and forces the water of the well up the suction-pipe, it follows, that the piston, at its greatest elevation, should never exceed the height of thirty-three feet from the surface of the water in the well.

Notwithstanding the common lifting pump, is incapable of raising water from more than thirty-three feet (in practice but thirty feet) below the place where it may be fixed, yet it may be made to deliver water at almost any required height above its piston, by the application of a continued straight pipe into the top of the working-barrel  $ab$  of the preceding figure. Thus, if we suppose twenty or thirty feet more of pipe to be so added to it, since the water once raised cannot pass downwards again through the piston valve, it must continue to rise with each stroke of the pump, until at length it will flow over the top of the pipe, or



through a spout inserted in any part of its side. In this case atmospheric pressure has nothing to do with the elevation of the piston, consequently it may be carried to any height that the strength of the pump, or the force employed, is capable of; but the handle *h*, or any other contrivance by which the pump is worked, must be fixed at the top of the additional pipe, and the piston-rod equally extended, in order that the working-barrel may be kept within the limits of atmospheric pressure, which makes a pump thus arranged inapplicable to very great depths, on account of the bending of the piston-rod. Where cast-iron pipes are used, this may in a great measure be prevented, by placing small pieces, with projecting arms of sufficient length to touch the inside of the pipe at each joint of the piston-rod, or about ten or twelve feet asunder, when this pump may be used for considerable depths with advantage. In using pumps to draw muddy or sandy water, it is always advisable to set the bottom of the pump in a close wicker basket, or other strainer, because sand and small stones very soon destroy the leather and working parts of any pump; and when pumps are used for hot liquors, which is the case in many manufactories, thick hempen canvas must be substituted for leather, unless the valves and pistons are made entirely of metal, which is of course preferable.

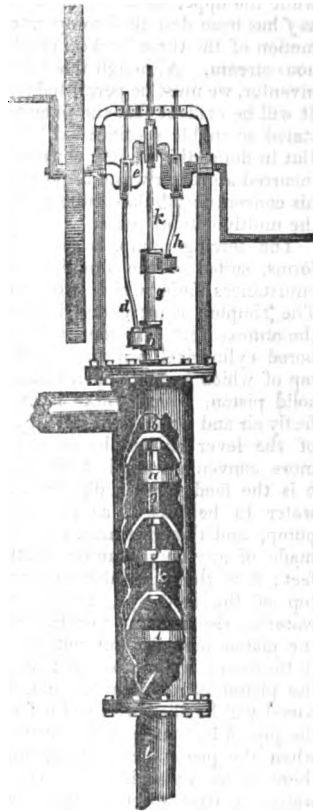
The *forcing pump* is generally employed in mines or in situations where it is required to draw water from great depths. Pumps of this kind act by compression instead of exhaustion. Although atmospheric pressure is not necessary to the construction of forcing pumps, yet it is in most cases resorted to for raising the water, in the first instance, into the body of the pump where the forcing action commences and takes place; and when so constructed, such pumps are usually called *lift and force pumps*; and in all the machines of this description, the water may be raised to any required height, without any limit, consistent with the strength of the parts and the power at command. Forcing pumps do not differ materially in construction from the common pump already described; indeed, that pump, by a mere inversion of its parts, may be made into a forcing pump; that is to say, placing the piston below, and the stop-valve and delivering-pipe above, as shown in the subjoined figure, where *h h* shows the inverted working-barrel, and *i* the inverted piston and rod, with a valve opening upwards; *k* is the stop-valve placed at the top, instead of the bottom, and also opening upwards into the rising pipe *ll*, which may be continued to any required height; the lower end of the working-barrel is quite open, and must stand in, and be covered with the water it has to raise, so that no suction or feed-pipe is necessary to this pump; and the piston *i* may be worked by a frame *oo*, or in any other convenient manner.



After the description already given of the common lift pump it will be needless to say anything of the action of this machine, as it is presumed the figure will render it sufficiently obvious. While the lower end of the working barrel *h h* is immersed in water, and the piston *i* moves upwards and downwards, the barrel will be filled through the piston-valve at each down-stroke, and at each up-stroke its contents will be expelled through the stop-valve *k*, into the ascending pipe *ll*; and whatever the diameter of this pipe may be, still its resistance will constantly be equal to the weight of a column of water of the size of the working-barrel, and of a height equal to the perpendicular altitude of the water in the ascending pipe; for this pipe may be placed horizontally or obliquely, so as materially to alter its length: but it is the perpendicular height between the surface of the water to be raised, and its point of discharge, which must alone

be taken into account in estimating the load upon a pump; since increase of length without height in the pipe produces no other resistance than that of friction, which is easily overcome by increasing the capacity of the pipe. It may appear that the preceding pump is applicable to every purpose and to every situation, such as raising water from mines and the deepest places; but this is not the case, owing to the almost imperceptibly small elasticity of water, and the effects of the *vis inertia*, which belongs to fluids in common with solid matter. In working the pump shown in the last figure, if we presume the pipe *ll* to be full of water, that water has not sufficient elasticity to permit the barrel *hh* to discharge its contents through the valve *k*, without putting all the water contained

in *ll* into motion, while, when the piston descends, that motion will be at an end. The water in *ll* will therefore be in an alternate state of rest and motion; and if the column is long, and its quantity great, the *vis inertia* will be very considerable; that is to say, it will require a considerable exertion of force to get it from a state of rest into motion; and when it has once begun to move, it will have no immediate tendency to return again to rest, but might be continued in its motion with less force than that which was originally employed to move it. The descent of the piston, however, allows sufficient time for all the motion that was communicated to be completely lost; and hence, in working this pump, we not only have the weight of the column to overcome, but the natural inertia to combat with at every stroke. This may, in a great measure be removed, by keeping two, or what is still better, three pumps constantly at work by a triple or three-throw crank; and accordingly this expedient is generally resorted to in all small engines for throwing water to a great height, for by this means the water is never permitted to stand still in the pipes, but a constant flow or stream is maintained. No illustration is necessary to explain to the reader the combination of three pumps worked by a triple crank, each throw giving the alternating motion to one pump of the series, at equal distances of time and space throughout the revolution; but a mechanical arrangement, wherein a triple crank is employed to work one pump, containing three buckets alternating in the same working barrel, and producing the same effect as three pumps, seems to require the aid of graphic delineation; accordingly, we annex

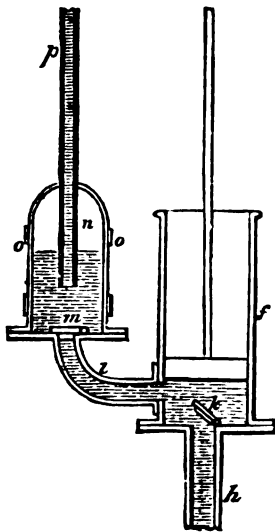


a cut, in which the process of raising water is thus conducted; it is the invention of Mr. Downton, of Blackwall, and was the subject of a patent granted to him in 1826. The figure in the margin may be called a front elevation, a portion of the working barrel or cylinder being broken away to show the buckets, &c. *a* is the uppermost bucket or piston, the rod of which *b b* is hollow, and being connected to a bent arm *d*, it is thereby attached to one of the limbs of a revolving three-throw crank *e*. The middle bucket *f* has also a hollow rod *g g*, which, being of smaller dimensions than the former, slides freely through it, and is connected to the crank *e* by another bent arm *h*. The lowermost bucket *i* has a solid rod *k k* which passes entirely through the hollow rods

of the other buckets, and is attached directly to the middle of the crank. Upon each of the limbs of the crank are placed anti-friction wheels, working in elliptical slots at the upper end of each rod, by which the attrition of the rubbing surfaces is considerably reduced.

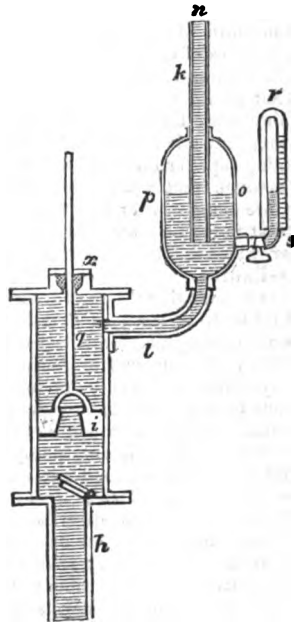
By this arrangement it will be seen that, on turning the crank by the winches, the buckets alternately receive and lift the water which has passed upwards through their valves. On raising the bucket *i* a vacuum is effected underneath, and the water rises from the main pipe *l*, and fills the lower part of the cylinder; on the descent of *i*, the water is received above it through its valve; while *i* descends, *f* rises, so that the water fills the space between the two; on the re-action of the bucket *i*, more water is received into the barrel from the main, while the upper bucket *a* operates upon the middle one *f* in the same manner as *f* has been described to operate upon *i*; thus, by the simultaneous alternating motion of the three buckets or pistons, the water is discharged in one continuous stream. Although this invention reflects credit upon the ingenuity of the inventor, we must be permitted to question its superiority over simpler machines. It will be evident that the patentee's object, (and, if we recollect rightly, it is stated so in his specification,) is to obviate the employment of an air vessel. But in doing this he has constructed a machine quite as expensive, and has incurred a greater waste of power, owing to the friction that must take place in his concentric tubular piston-rods; besides a greater liability to derangement by the multiplicity of parts.

The forcing pump is made in two forms, suited to the situation and circumstances under which it has to work. The simplest construction is shown in the annexed cut. It consists of a truly-bored cylindrical working-barrel *f*, the top of which is quite open to admit the solid piston, which works it in a perfectly air and water-tight state, by means of the lever or handle, or any other more convenient application of power; *h* is the feeding-pipe, dipping into the water to be raised, as in any other pump, and this pipe may, of course, be made of any length under thirty-three feet; *k* is the stop-valve covering the top of the feed-pipe, and permitting water to rise into the working-barrel as the piston ascends, but not permitting it to return again; so that whenever the piston is raised by its handle, the barrel will be filled with water forced up the pipe *h* by atmospheric pressure; and when the piston descends again, since there is no valve in it to permit the water to pass through it, it will be forced up the lateral pipe *l* (opening into the bottom of the working-barrel) and through the valve *m*, which prevents its returning back again, so that it is constrained to find its way up the rising pipe *p*, fixed above the valve *m*; and this pipe may be continued to any required height, without regard to the pressure of the atmosphere, since the ascent of the water does not depend upon its action, but upon the mechanical force that is applied to the handle to depress the piston. While the piston rises to fill the working-barrel, the valve *m* will be shut, and of course all motion of the fluid in the pipe *p* will cease, and hence the use of the air-vessel *n*; for it will be seen that the pipe *p* is not joined on immediately above the valve *m*, but that it passes through the top of an air-tight copper, or other hollow vessel *n*, and proceeds nearly to the bottom of it. Air being a lighter fluid than water, will of course occupy the upper part



of this vessel; and as soon as the action of the pump has filled it with water up to the line  $o$ , or just above the lower end of the open pipe  $p$ , all air that is above the water will be confined, and unable to escape. If, now, the working of the piston be supposed to throw water more rapidly into the air-vessel than it can escape by the pipe  $p$ , it is evident that such confined air will be condensed into less compass than it naturally occupies, in order to make room for the water; and as the elasticity of air is constant, and increases in power with its degree of condensation without limitation, so the spring of the air in the air-vessel will become a counterpoise or equivalent for any height to which the pipe  $p$  may be carried; and although the water in the pump explained at page 357, would not admit of condensation so as to permit a fresh quantity of water to enter the ascending-pipe without putting all its contents into motion, yet the introduction of the air-vessel obviates this difficulty; for now the new quantity of water is not delivered into a former quantity of inelastic water, but into a vessel filled with air, which readily allows a change of dimensions; and while the piston is rising, and projecting no water, the previously condensed air in  $n$  has time to re-expand into its former volume, by expelling an equivalent quantity of water up the pipe  $pp$ ; and thus, if the air-vessel is large enough, a constant and equable current may be maintained.

The annexed figure shows another form of the forcing pump, though this construction is generally called the lift and force pump; its formation is the same as the last-described figure, except that the piston is not solid, but is perforated, and covered by a valve opening upwards, as in the common lifting-pump; the piston-rod  $q$  likewise moves in an air-tight manner through a stuffing-box, or collar of leather, on the top of the working-barrel, which, in this case, is closed; and the lateral delivering-pipe, with its air-vessel, proceeds from the upper instead of the lower part of the working-barrel. This pump not only has the stuffing-box, but three valves, instead of two, as in the last example: it is, consequently, rather more intricate and expensive in its construction, with no other advantage than that it is rather more cleanly in its working; for if the piston of the former pump is not quite water-tight, a quantity of water may flow over the open top of its working-barrel, which cannot be the case in this pump, if well made. Their action is very nearly alike, for this last pump raises water through the suction-pipe  $h$ , by the elevation of the piston  $i$ ; on depressing the piston, that water passes through it by its valve, and



gets above it to fill the upper part of the working-barrel; on the re-ascend of the piston, the water, being unable to escape at the top of the barrel on account of the cover and stuffing-box  $x$ , is forced up the lateral pipe  $l$  into the air-vessel, and from thence passes away by the ascending-pipe  $k$  as before. When the water has risen in the air-vessel to the dotted line  $po$ , so as to cover the lower end of this pipe, the air will be confined, and their operations must be alike. The air-vessel must be suited in its capacity to the magnitude of the pump or pumps that deliver water into it (for several pumps are frequently made to open into one common air-vessel), and ought, in all cases, to contain at least six or eight

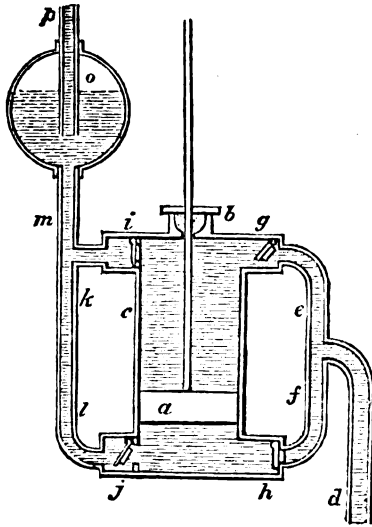
volumes of the pump, in order that the increasing expansive force of the air may not influence the motion of the piston during a single stroke; but for this no precise rule can be given, as the relative dimensions may vary to suit the circumstances of the case. These forcing pumps with air-vessels are now very generally adopted in water-works for supplying cities or towns; and the height at which the water is at any time delivering, may be very nearly estimated if the air-vessel is large, and the supply equable, by examining the degree of condensation of the air within it. This is very conveniently done by a gauge, consisting of a glass tube with a closed top, applied by a stop-cock to the lower part of the air-vessel, or that which is always filled with water; at *rs* such a gauge is represented; and as it has an open communication with the air-vessel when the cock *s* is open, the air in the top of the tube will suffer the same condensation as that within the vessel. The height of the spaces occupied by air within the tube must be measured; and as the air at its ordinary density will balance a column of water thirty-three feet, high, so if confined air is loaded with the weight of such a column, it will shrink, or be condensed into half its former bulk; whenever, therefore, the air contained in the tube *r* is diminished to half its original length, the condensation within the air-vessel must be equal to two atmospheres: or, what is the same thing, the water in the pipe *p* must stand at the elevation of 33 feet. If the water in *p* is raised to twice 33 feet, or 66 feet, then the condensation within the air-vessel must be equal to three atmospheres; and the air within it, as well as within the tube, will be diminished to one-third of its original bulk; one-fourth of the bulk will indicate four atmospheres of condensation, and be equal to the elevation of the water column to 132 feet, and so on, more or less, as the barometer may vary.

That useful machine, the fire-engine, or engine for extinguishing fires, is nothing more than two forcing-pumps, of the construction shown at page 358. working into one common air-vessel placed between them, and from which the spouting-pipe for directing the water upon the fire proceeds. The handles are so disposed, that while the piston of one pump is up, the other is down; and they are elongated for the purpose of enabling a great number of men to work them at the same time, for the purpose of throwing a very large quantity of water, which is rendered a continuous stream by the action of the air-vessel. See FIRE-ENGINE.

It is curious that the most ancient pump we are acquainted with, namely, that of Ctesibius, at least, as it is handed down to us, very closely resembles the present fire-engine, for it consists of two forcing-pumps, disposed as just described; but instead of discharging their contents into an air-vessel, they merely deliver them into an intermediate close cistern, from which the water ascends by a perpendicular pipe, and in which nothing is wanting but the condensation of air. It must, however, be observed, that both the pumps last described would be forcing pumps, without their respective air-vessels; and though they act much more advantageously with, they are sometimes constructed without those appendages.

We now proceed to describe a pump with a double action, producing the same effect in its up as in its down-stroke; the water being alternately raised and forced on the opposite sides of the piston; that is to say, by the up-stroke of the piston, the water above it is forced out of it into an air-vessel, and, at the same time, the cylinder is re-charged by the water following the piston underneath; then by the return or down-stroke, the water underneath is forced out, and it flows in above, ready for the repetition of the operation, and so on continuously. In the diagram on the following page, *a* represents a solid piston, its rod working air-tight in a stuffing-box *b*, fixed at the top of the pump-barrel *c c*. The water from the well, supposed to be not more than thirty feet deep, ascends into the vacuum of the pump by the pipe *d*, and is conducted by a branched pipe *e f* to the top and bottom of the barrel alternately, through valves *g* and *h*, which open inwards. On the opposite side of the working-barrel are two corresponding apertures, furnished with valves *i* and *j*, opening outwards, and conducting the water by a branch-pipe *k l* into a single tube *m*, leading into an air-vessel *o*, whence it is discharged by the tube *p*. In the

figure, the piston is shown as having nearly reached the bottom of the cylinder; by the force thus exerted it has shut the valve *h*, and impelled the water through the valve *j*, the branch *l*, and pipe *m*, into the air-vessel *o*, where the elasticity of the air, pressing upon the surface of the water, has forced it up the pipe *p*. During this operation there has been a tendency to the production of a vacuum above the piston; consequently, the pressure of the air, acting upon the surface of the water in the well, has compelled it to follow the piston in its descent, and to fill the chamber above; afterwards, upon the ascent of the piston, the upward force shuts the valve *g*, and opens the valve *i*, through which the water is propelled along the branch *k*, pipe *m*, air-vessel *o*, and out of the pipe *p*. During this ascending stroke, the water from the well passing along *d* and *f*, has opened the valve *h*, shut the valve *j*, and re-filled the barrel under the piston; and thus the process is continued as long as the pump is worked.

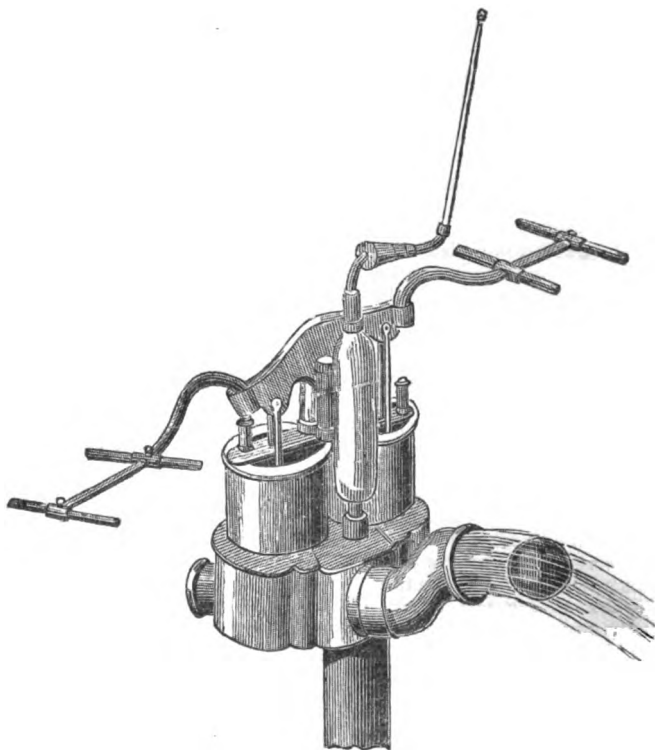


Mr. George Vaughan, of Mile-end Old Town, took out a patent in 1830 for a double-acting pump, acting in a horizontal direction; the principle of its operation may be readily understood after the description of the foregoing, and by comparing it to a high-pressure steam engine, with such difference only as to adapt it better to the pumping of water. The working chamber is either cylindrical or square; but each end of it is considerably enlarged downward, where the valves that receive the water from the rising main are situated. The piston is solid and packed like those for steam; the piston-rod passes through a stuffing-box at one end of the chamber, and is attached, at the farthest extremity, to a cross head, to which is connected two spear-rods. One of these rods passes on each side of the pump, and beyond the opposite end of it, to a crank, which is made to revolve in plummer blocks (fixed to a suitable frame), and is turned either with a winch, by manual labour, or by any other suitable power. The motion thus described is, of course, nothing but the ordinary parallel motion. In order that the piston may not, by its weight, wear most on its under side, the piston-rod is continued on both sides of it; and beyond the range of the piston, the rod is supported by an anti-friction wheel; thence the rod enters a tubular case, closed at the furthest extremity to prevent the escape of the water, as it is not packed. The action of the pump is this: suppose, by the revolution of the crank, the piston to be moving to the right hand, a vacuum is produced on the opposite side of the piston, which causes the valve from the rising main to be opened by the pressure of the atmosphere, and the chamber is thereby filled with water. On reversing the stroke of the piston, or towards the left, the right-hand valve is opened from the rising main, and that end of the chamber filled with water, while the water which previously occupied the left end of the chamber is forced out by the piston through another valve on the upper side; the succeeding stroke in like manner discharges the water in the right chamber, and fills that of the left, and thus the action is continuous. In the drawing attached to the specification, a large semi-cylindrical wheel is shown as fixed to the upper side of the pump, for the reception of the water delivered through the upper valves, and in the crown of the arch is a pipe for conducting the water, if required, to a greater elevation.



It would obviously have been better, had the patentee made the upper part of this vessel into an air-chamber, by causing the ascending-pipe last mentioned to dip nearly to the bottom of it.

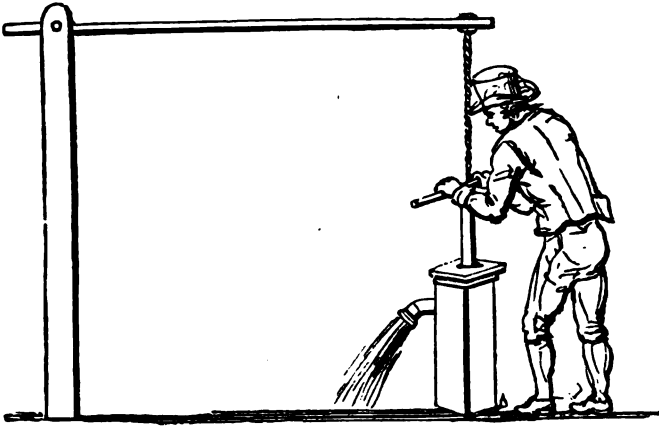
The annexed engraving is a representation of a pump constructed by Mr. Clymer, on the plan of the ingenious Benjamin Martin; but the suction-pipe and the valves are so disposed as to retain any heavy bodies that may be raised by the pressure of the atmosphere acting upon the vacuum.



The above perspective sketch shows that the rising main leads into a spacious valve-box, in connexion with two short and wide working-barrels, left open to the atmosphere. The piston-rods are attached to a lever, vibrating on a central fulcrum which is mounted upon a standard between the two cylinders; and to this lever branching handles are united, to enable many hands to be employed in working it. The large volume of water discharged from the barrels at each stroke of the pump causes a constant powerful stream up the rising main, so that any globular substances nearly fitting it, as cannon balls, have no opportunity to fall down by any intermission of pressure from underneath; they consequently get lodged in the valve-box, and are ejected by the down-stroke of the pump. When employed as an engine to discharge water to a great height or distance, an air vessel is screwed on, as represented, and the nozzle is then plugged or capped, by which the current is directed through the air vessel.

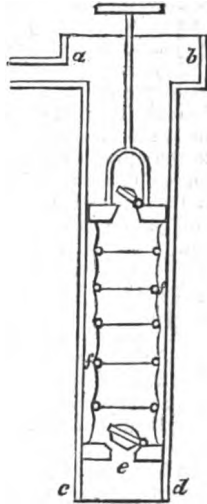
In drawing water from great depths, the weight of the pump-rods and the water together are sometimes more than can be easily accomplished by the

power at command; in such cases we have occasionally observed, in country places, a very simple apparatus, similar to that represented in the following cut,



employed to counterbalance the weight of the rods. In this case, the pump-rod and handle is suspended to a wooden spring, of sufficient elasticity to sustain the weight of the rods, and to require a part of the man's force to depress the piston or bucket, in return for which the spring assists him in the pull upwards. Some persons would be apt to imagine that power was thus gained; but a little consideration will enable them to perceive that it is only by a different distribution of the same force that the desired effect is produced.

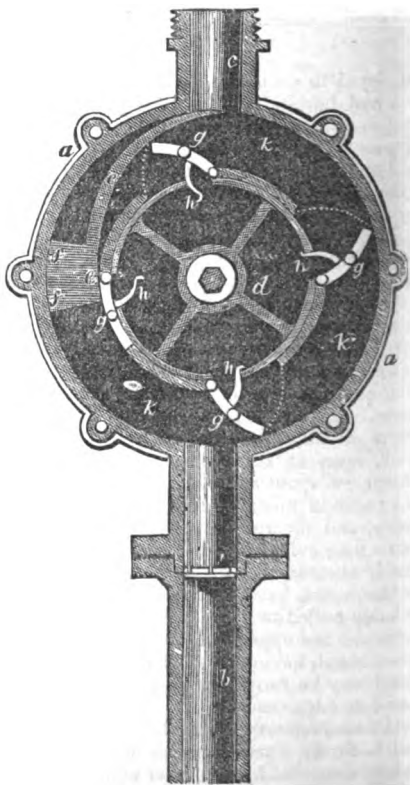
In Dr. Gregory's *Mechanics*, vol. ii. is the following description of a pump, with little friction, which may be constructed in a variety of ways by any common carpenter, without the assistance of a pump-maker or plumber, and which will be very effective for raising a great quantity of water to small heights, as in draining marshes, marl-pits, quarries, &c., or even for the service of a house. It is exhibited in the subjoined diagram, where *abcd* is a square trunk of carpenter's work, open at both ends, and having a little cistern and spout at top. Near the bottom there is a partition made of board, perforated with a hole *e*, and covered with a clack; *ffff* represent a long cylindrical bag, made of leather or of double canvass, with a fold of thin leather, such as sheep-skin, between the canvass bags. This is firmly nailed to the board *e*, with soft leather between; the upper end of this bag is fixed on a round board, having also a hole and valve. This board may be turned in the lathe with a groove round its edge, and the bag fastened to it by a cord bound tight round it. The fork of the piston-rod is firmly fixed into this board; the bag is kept distended by a number of wooden hoops, or rings of strong wire *ff, ff, ff*, &c. put into it,



at a few inches distance from each other. It will be proper to connect these hoops, before putting them in, by three or four cords, from top to bottom, which will keep them at their proper distances; thus will the bag have the form of a

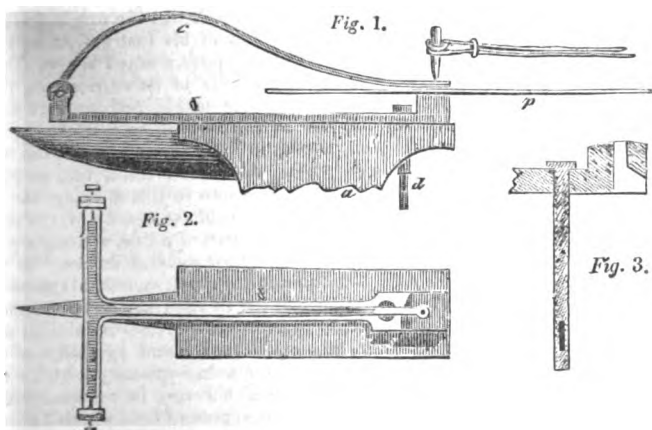
barber's bellows or powder-puff. The distance between the hoops should be about twice the breadth of the rim of the wooden ring to which the upper valve and piston-rod are fixed. Now let this trunk be immersed in the water. It is evident, that if the bag be stretched from the compressed form which its own weight will give it by drawing up the piston-rod, its capacity will be enlarged; the top valve will be shut by its own weight; the air in the bag will be rarefied, and the atmosphere will press the water into the bags. When the rod is thrust down again, this water will come out by the top valve and fill part of the trunk. A repetition of the operation will have a similar effect; the trunk will be filled, and the water will be discharged by the spout.

Many attempts have been made to introduce pumps worked by a continuous rotary motion, and a great deal of ingenuity has been exercised to prevent that waste of power arising from friction, with which they have all been more or less accompanied, but in a greater degree than the best reciprocating pumps. The reader who is solicitous for information on this point will find numerous descriptions of patented inventions of the kind in the *Repertory*, the *London Journal*, the *Register of Arts*, &c.; but as none of them have, in our opinion, been yet brought to work so well as the reciprocating pump, we shall here add only one of those contrivances, which possesses as strong claims to notice as any of them. It was the subject of a patent granted to Mr. Robert Winch, of Battersea, in 1826, and is delineated in the subjoined cut, which represents a vertical section. At *aa* is a cylindrical case of metal, the holes at the circumference being for the bolts, by which the circular side-plates are secured to it; *b* is the rising main pipe from the well; *kkk* the water-way, and *c* the discharge pipe; *d* is a circular box, turned round upon the hexagonal shaft in the centre by a winch outside. To the periphery of this circular box the flap-pistons *gggg* are fixed by joints, and, as they revolve, they are successively closed as they come in contact with a "circular inclined plane" *ee*, the under side of which forms a stop to the upward course of the water on that side of the cylinder. On passing the curved piece *e*, the pistons successively fall open, with their edges touching the interior surface of the pump case; the water which has passed up from the main pipe through the valves *ii*, and occupied the spaces marked *kk*, is then carried forward by the pistons as they revolve, and is discharged in a continuous uniform stream at *c*. To prevent the pistons from striking violently against the cylinder, as they are turned against it by the resistance of the water, as well as to avoid hard rubbing in those parts, catch-hooks *hhhh* are employed, the action of which is too obvious in the drawing to require more explanation



To facilitate the shutting of the flap-pistons, as they come in contact with the curved piece *c*, each of them have a second joint in the middle, which gives them great flexibility of motion. In another modification of this invention, the patentee employs a rotary vane for closing the flap-pistons or valves in succession, instead of the curved stop described; but this arrangement renders it necessary to have a toothed wheel fixed to the axis of the circular box, to work a pinion on the axis of the rotary vane, that the motion of the latter may exactly correspond with that of the pistons. Since it is impossible, when a pump is well made and is in good order, that the piston can move without displacing the water that is above or below it, according to the circumstances of its construction, so, in all pumps that consist of cylindrical working-barrels and pistons, nothing more is necessary to ascertain the quantity of water they will deliver, than to calculate the solid or cubical contents of that part of the barrel in which the vacuum is produced, and to reduce it to some standard measure, and then to multiply this by the number of strokes made in a given time: thus, if a pump is nine inches diameter, and makes an effective stroke of about eighteen inches, such a cylinder will be found to contain 1134 cubic inches; and as 277½ cubic inches make an imperial gallon, so four gallons will be equal to 1109 cubic inches; consequently, such a barrel will contain and throw out rather more than four gallons at every stroke; and supposing this pump to make ten strokes in a minute, it would yield above forty gallons in a minute, or sixty times that quantity in an hour, and so on. This rule applies in every case, whether the water is sent to a small or great elevation, because the piston cannot move without displacing the water in the barrel; but a small allowance must be made for leakage, or waste, because some water will constantly pass the piston and escape, or be otherwise lost and wasted.

**PUNCH, AND PUNCHING.** A punch is a short, stout piece of steel, or iron steeled, used for stamping out pieces of metal, so as to make perforations in iron or other plates, for the insertion of rivets, screws, bolts, &c. In punching thick plates of metal, a powerful machine, consisting of a long and massive lever, worked by an engine, is generally used in considerable works; but as such machines are only in the possession of the comparatively few who require work of the kind to be well and expeditiously done, a simple and cheaply-constructed instrument for the purpose becomes an important appendage to the workshop; and such an instrument we here present to the reader, which has



been long and advantageously employed by Mr. J. R. Hill, of the Westminster Road. *Fig. 1* shows a side view of the machine, fastened on an anvil *a*, by a cutter-bolt *b*. *Fig. 2*, a bird's-eye view of the same. *Fig. 3*, a section of the

punching-hole, showing a part cut out for the pieces to fall out; *pp* is a plate to be punched; the back end of the lower part of *b* is furnished with a T piece, each end of which is turned up and tapped for the reception of a centre screw. On these centre screws hangs the guide-arm *c*, which is also T shaped; the other end of this guide-arm has a hole *c*, just the size of the point of the punch to be used: in order to bring this hole to coincide with the lower one, it is only necessary to lengthen or shorten the arm, by bending it a little more or less, and turning the screws a little either way, which must be granted is much easier than adjusting a punch sliding in square holes, guides, &c. The set screws are also furnished with a nut each, to set them fast when adjusted. The reason for making it so long is, that any width of plate may come inside the holes. It is scarcely necessary to add, that a common rod-punch is used with its point only filed up to fit the hole.

**PURLINES.** Pieces of timber extending from one end of a roof to the other; they pass under the middle of the rafters, which they support, and counteract their tendency to sink in the middle.

**PUTTY.** A cement used by glaziers for fastening window-glass into the frames; it is used also by carpenters and other artisans for stopping holes in their work: it is made by kneading whiting and linseed oil together into a stiff paste; when dry it is very hard and durable.

**PUTTY, POWDER OF.** An oxide of tin, much used in polishing glass and other hard substances. When tin is melted in an open vessel, its surface soon becomes covered with a grey powder, which is the oxide of the metal. If the heat be continued, the grey assumes a yellow tint, which is then called putty.

**PUZZOLANA.** A kind of earth thrown out of volcanoes; it is of rough, dusty, granular texture. It easily melts *per se*; but its most important property consists in its forming a cement, when mixed with one-third of its weight of lime and water, which hardens very suddenly, and is more durable under water than any other cements.

**PYRITES.** Native compounds of metal with sulphur. The principal in this country are the sulphurets of iron, called martial pyrites, worked for the sake of the sulphur they contain; the sulphurets of copper are worked for both the copper and the sulphur they contain.

**PYROLIGNEOUS ACID.** See ACID PYROLIGNEOUS.

**PYROMETER.** A machine contrived to measure the expansion of metals, and other bodies, occasioned by heat. Muschenbroeck was the original inventor of the pyrometer; the nature and construction of his instrument may be understood from the following account.—If we suppose a small bar of metal, twelve or fifteen inches in length, made fast at one of its extremities, it is obvious that if it be dilated by heat it will become lengthened, and its other extremity will be pushed forwards. If this extremity then be fixed to the end of a lever, the other end of which is furnished with a pinion adapted to a wheel, and if this wheel move a second pinion, the latter a third, and so on, it will be evident that, by multiplying wheels and pinions in this manner, the last will have a very sensible motion; so that the moveable extremity of the small bar cannot pass over the hundredth or thousandth part of a line, without a point of the circumference of the last wheel passing over several inches. If this circumference then have teeth fitted into a pinion, to which an index is attached, this index will make several revolutions, when the dilation of the bar amounts only to a quantity altogether insensible. The portions of this revolution may be measured on a dial plate, divided into equal parts; and by means of the ratios which the wheels bear to the pinions, the absolute quantity which a certain degree of heat may have expanded the small bar can be ascertained; or conversely, by the dilatation of the small bar, the degree of heat which has been applied to it may be determined. Such is the construction of Muschenbroeck's pyrometer. It is necessary to observe, that a small cup is adapted to the machine, in order to receive the liquid or fused matters subjected to experiment, and in which the bar to be tried is immersed. When it is required to measure by this instrument a considerable degree of heat, such as that of boiling oil or fused

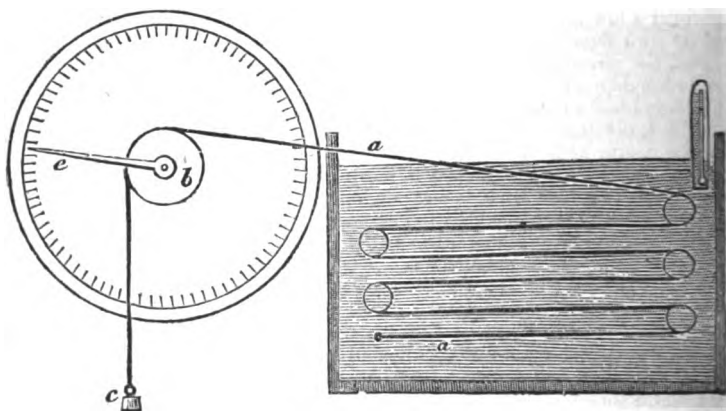
metal, fill the cup with the matter to be tried, and immerse the bar of iron into it. The dilatation of the bar, indicated by the index, will point out the degree of heat it has assumed, and which must necessarily be equal to that of the matter into which it is immersed. This machine evidently serves to determine the ratio of the dilatation of metals, &c.; for by substituting in the room of the pyrometric bar other metallic bars of the same length, and then exposing them at an equal degree of heat, the ratios of their dilatation will be shown by the motion of the index.

The most celebrated instrument for measuring very high temperatures, is that invented by the late Mr. Wedgwood, founded on the principle, that clay progressively contracts in its dimensions, as it is progressively exposed to higher degrees of heat. He formed white porcelain clay into small cylindrical pieces, in a mould, which, when they were baked in a dull red heat, just fitted into the opening of two brass bars, fixed to a brass plate, so as to form a tapering space between them. This space is graduated, and the farther the pyrometric gauge can enter the greater heat does it indicate. The limits of the converging scale are five-tenths of an inch at the beginning towards the opening, and three-tenths at the end, or towards the line to which the bars converge. The next thing to be done, was to ascertain and establish a connexion between the indications of his instrument and those of the mercurial thermometer; to accomplish this, he employed a heated rod of silver, of which he measured the expansion. The clay piece and the silver rod were heated in a muffle, and as soon as the muffle indicated a low red heat it was drawn forward towards the door of the oven; and its own door being then nimbly opened by an assistant, Mr. Wedgwood pushed the silver rod as far as it would go. But as the division to which it reached could not be distinguished in that ignited state, the muffle was steadily and cautiously lifted out, and left to cool. When the muffle was sufficiently cold to be examined, the degree of expansion at which the silver stood was carefully noted, and the degree of heat shown by the clay pieces was measured by their own gauge; after which, the whole was returned into the oven, and exposed to a more intense heat, in order to obtain another point of correspondence between the two scales, the graduated silver rod serving as an intermediate scale, with which Wedgwood's and Fahrenheit's might be readily compared. The first of these points of correspondence was  $2\frac{1}{4}^{\circ}$  of Wedgwood's, to  $1370^{\circ}$  of Fahrenheit's; the second was  $6\frac{1}{4}^{\circ}$  of Wedgwood's, to  $1890^{\circ}$  of Fahrenheit's. Hence, because  $6\frac{1}{4} - 2\frac{1}{4} = 4$ , and  $1890 - 1370 = 520$ , it appears, that an interval of 4 degrees on Mr. Wedgwood's instrument is equivalent to 520 degrees on that of Mr. Fahrenheit's, and consequently, that 1 degree of the former equals  $\frac{130}{4}$  of the latter, and the zero (or 0) on Wedgwood's scale corresponds with 1077 and a fraction on Fahrenheit's. Hence, we have the means of reducing the degrees at any point of one scale, to the corresponding degrees on the other, through the entire range. Mr. Wedgwood's instrument includes an extent of about 31,200 of Fahrenheit's, or about 50 times that between the freezing and boiling points of mercury, by which points the performances of mercurial thermometers are necessarily limited. Also, if we conceive Mr. Wedgwood's scale to be extended downwards below his zero, as Fahrenheit's is supposed to extend upwards above the boiling point of mercury, the freezing point of water will fall on  $8^{\circ}.421$ , or somewhat above  $8\frac{1}{4}^{\circ}$  below the zero of Wedgwood's scale, and that of mercury on  $8^{\circ}.596$ , or a little below  $8\frac{1}{2}^{\circ}$ ; so that the distance between the freezing points of mercury and water is an interval of .175 of a degree on Wedgwood's scale;  $8^{\circ}$  and a decimal from the freezing point of water to complete ignition; and  $160^{\circ}$  is the highest point or degree of heat to which our ingenious philosopher was able to extend his observations.

"Since dry air," observes Dr. Ure, "augments in volume three-eighths for 180 degrees, and since its progressive rate of expansion is probably uniform by uniform degrees of heat, a pyrometer might easily be constructed on this principle:—form a bulb and tube of platinum, of exactly the same form as the thermometer, and connect with the extremity of the stem, at right angles, a glass tube of uniform calibre, filled with mercury, and terminating below in a curved bulb, like that of the Italian barometer. Graduate the glass tube into

a series of spaces equivalent to three-eighths of the total volume of the capacity of the platina bulb, with three fourths of its stem. The other fourth may be supposed to be little influenced by the source of heat. On plunging the bulb and two-thirds of the stem into a furnace, the depression of the mercury will indicate the degree of heat. As the movement of the column will be very considerable, it will be scarcely worth while to introduce any correction for the change of the initial volume by barometric variation; or the instrument might be made with the recurved bulb sealed, as in Professor Leslie's differential thermometers. The glass tube may be joined by fusion to the platina tube. Care must be taken to let no mercury enter the platinum bulb. Should there be a mechanical difficulty in making a bulb of this metal, then a hollow cylinder, of half an inch diameter, with a platinum stem, like that of a tobacco pipe, screwed into it, will suit equally well.

A very convenient pyrometer for ascertaining the relative expansibility of the various metals that can be drawn into wire, was contrived by Mr. Gurney, which he employed in his chemical lectures. It is represented in the subjoined cut. *a* represents a wire of the metal to be examined, attached at the lower end to a peg fixed upon a piece of board; on this board is also a series of little pulley-wheels, turning freely on their axes, and around the peripheries of these wheels the wire is carried to the uppermost, whence it is conducted out of



the vessel, and over a small central wheel *b*, of a circular graduated scale, and with a weight *c* tied to this end of the wire, which keeps it in a state of tension. Thus prepared, the apparatus is immersed in a vessel of water, or other fluid, heated to the desired temperature within their capability, which is determined by a thermometer placed therein. The expansion which then takes place is accurately denoted by the index *e* pointing it out upon the graduated circumference, the index turning round as the elongation takes place. Upon abstracting the heat, the wire contracts and draws back the wheel and index to its previous position. An instrument of this kind, carefully constructed, and with a smaller central wheel *b*, would, without doubt, show the expansibility of the ductile metals with great exactness, and very satisfactorily, as the wire may be of great length, be wound round a large number of pulleys, so as to cause an obvious elongation of an inch or more.

**PYROPHORUS.** An artificial product, which takes fire upon exposure to the air, and hence called air-tinder. It is prepared from alum by the addition of various inflammable substances. The simplest mode of preparing it is to mix three parts of alum with one of wheat flour, and calcine them in a phial or matrass, until the blue flame disappears, then keep it in the same phial till

cold, well stopped with a good cork. In this powder be exposed to the atmosphere, the sulphuret attracts moisture from the air, and generates sufficient heat to kindle the carbonaceous matter mingled with it.

**PYROTECHNY** is, properly speaking, the science which teaches the management and application of fire in various operations; but in a more limited sense, and as it is more commonly used, it refers chiefly to the composition, structure, and use of artificial fireworks. The ingredients are, 1. saltpetre, purified for the purpose; 2. sulphur; and 3. charcoal. Gunpowder is likewise used in the composition of fire works, being first ground, or, as it is technically termed, mealed. Camphor and gum benzoin are employed as ingredients in odoriferous fireworks. The proportions of the material differ very much in different fireworks, and the utmost care and precaution are necessary in the working them to a state fit for use, and then in the mixing. In this work we cannot enter on the subject with a sufficient degree of minuteness to teach the method of manufacturing fireworks, and shall therefore content ourselves with a brief notice of the proportions of the materials in some of the more common and more interesting articles in use. The charges for sky-rockets are made of saltpetre, four pounds; brimstone, one pound; and charcoal, one pound and a half; or by another direction—saltpetre, four pounds; brimstone, one pound and a half; charcoal, twelve ounces; and mealed powder, two ounces. These proportions vary according to the size of the rocket; in rockets of four ounces, mealed powder, saltpetre, and charcoal, are used in the proportions of 10, 2, and 1; but in very large rockets, the proportions are saltpetre, 4; mealed powder and sulphur, 1 each. When stars are wanted, camphor, alcohol, antimony, and other ingredients are required, according as the stars are to be blue, white, &c. In some cases gold and silver rain is required; then brass-dust, steel-dust, saw-dust, &c. enter into the composition; hence the varieties may be also indefinite. With respect to colour, sulphur gives a blue, camphor a white or pale colour; saltpetre, a clear white yellow; sal-ammoniac, a green; antimony, a reddish; resin, a copper colour.

## Q.

**QUADRANGLE.** A figure containing four angles and four sides.

**QUADRANT**, in Geometry, the quarter or fourth part of a circle, and therefore containing an angle of 90 degrees.

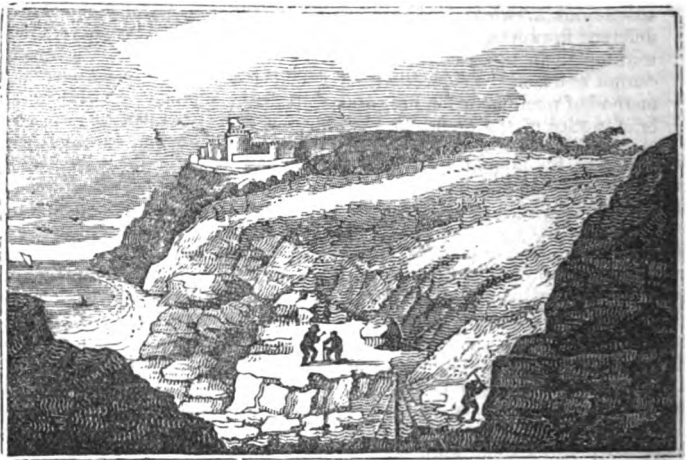
**QUADRANT** also denotes a mathematical and optical instrument, of great use in navigation and astronomy, for taking the altitude of the sun and stars.

**QUADRAT**, in Printing, is a piece of metal cast like the type, to fill up the spaces between words; they are made of different sizes, called by the space they occupy, as *m* quadrats, *n* quadrats, &c.

**QUARRY.** A cavity or opening made by miners in rocky ground, from which are procured marble, freestone, slate, limestone, or other materials; one of which, in the island of Jersey, is represented in the subjoined cut; from whence is obtained large quantities of stone for the London pavements. It is of essential importance that such works should be situated close to the sea, or a river, or canal, for the convenient and cheap transport of the heavy product, as it is the cost of carriage which constitutes its chief cost. The mode of separating the stone from the rock differs according to its natural formation; but in granitic and other hard rocks of continued solidity, the process, though apparently difficult, is extremely simple, as it consists chiefly in boring holes with various instruments, (which have been described, as well as the process, under the word **BLASTING**;) then ramming into the hole a charge of gunpowder, laying a train to it, firing the train, and retreating to a distance or under an overhanging cliff to avoid the stones which are thrown up by the explosion.



The holes are made from one to three feet in depth, and generally about 1½ inch diameter; but these, as well as the position and direction of the perforation, and also the charge of the powder, are subject to the skill and discretion of the miner. The rules by which he is guided are, to direct the effort of the explosion to a part of the rock which is most easily displaced, and to proportion the charge to the effect required, so as to shake and loosen a larger portion rather



than to blow out a less quantity. The danger of beating the tamping bar with iron tools in hard rock, and the many dreadful accidents that frequently happen in this operation, have led to the introduction of contrivances to diminish the risk; but though some of these have been well adapted for the purpose, yet, as they occasion a little more trouble, they have not been generally adopted by the miner. The simplest and best precaution against danger, is to have the nail of copper, instead of iron; but as the former is not so easily made or repaired by the smiths on a mine as the latter, they are not so well liked by the workmen. Another mode of preventing danger in tamping, is by employing substances to confine the gunpowder which require little or no force in beating them into the hole; and as dry sand will often serve the purpose if the rock is not very hard, it may be sometimes used; but there are many cases in mines where it will not succeed, and therefore it is seldom attempted. A better substance to confine gunpowder in holes, is good tough clay, and this will answer in many cases where sand will fail, particularly in wet ground, or in holes that are inclined upwards; it will produce the proper effect in all but very hard rocks, and, if the men could be induced to use it, would undoubtedly tend to the saving of many lives.

An instrument, denominated by the inventor, the "*Miner's Safety Fuse*," was patented in 1831 by Mr. Bickford, of Tucking Mill, Cornwall; which may be briefly described as consisting of a minute cylinder of gunpowder, or other suitable explosive mixture, enclosed within a hempen cord, which is first twisted in a peculiar kind of machine, then countered or overlaid to strengthen it, afterwards varnished with a mixture of tar and resin, to preserve the combustible matter from the effects of moisture, and finally coated with whitening, or other light pulverulent matter, to prevent the varnish from sticking to the fingers, or the fuses to one another. These fuses appear, from the specification, to be very judiciously and accurately prepared, and will, we doubt not, be found of great utility in mining operations.

For facilitating the operation of boring rocks, a patent has lately been taken

out in the United States of America, which is thus described in the *Journal of the Franklin Institute*. "A frame is made, in the centre of which an iron shaft or rod is caused to rise and fall vertically between friction rollers, so placed as to keep it in its position. In the lower end of this shaft, a socket is formed, to receive drills of different sizes. Provision is made for placing the machine vertically, by sliding pieces upon each of its four legs, which serve to lengthen them as may be necessary. The apparatus for working the shaft up and down, is formed as follows: a circular plate of iron, about a foot in diameter, has a hole in its centre, provided with a socket adapted to the iron rod or shaft, and capable of being secured at any part of it, so that the plate will stand horizontally. At a little distance from the periphery of this plate, an iron spindle crosses the frame; upon this spindle are lifters, which, as it is turned by a crank, come in contact with the lower side of the plate, and raise the shaft; friction rollers are contained within the lifters, to cause them to slide easily upon the plate, and their action is so managed as to produce a small revolution of the plate, and consequently of the drill, at every lift."

The term *quarry* is likewise given to a variety of neatly formed bricks, tiles, and stones, with very level surfaces, and of diversified colours; which are employed in many parts of England, as well as other countries, for making plain and ornamental flooring. The perforated tiles employed in malt-kilns, some kinds of drying stoves, and for various other uses, receive this denomination. An improvement in the construction of quarries, applicable to kilns for drying malt, wheat, and other grain, was lately patented by Mr. Henry Pratt, (a gentleman of great skill and knowledge in such subjects,) of Bilston, in Staffordshire; the peculiarities of which may be thus briefly explained. Instead of the usual conical openings, terminating in small circular apertures in the flooring of grain kilns, Mr. Pratt forms his quarries for such purposes of cast-iron, in preference to baked clay, having oblong slots or openings at the tops of rectangular tapering holes, which are designed for the escape of the heated air. He casts his quarries with strengthening bars projecting from their lower sides, and these bars form the sides of the tapering channels, as well as give sufficient strength with a less quantity of material than is required when the quarries are made of an uniform thickness.

**QUARTATION.** An operation by which the quantity of one thing is made equal to the fourth part of the quantity of another thing. Thus, when gold alloyed with silver is to be parted, we are obliged to facilitate the action of the aquafortis by reducing the quantity of the former of these metals to one-fourth part of the whole mass; which is done by sufficiently increasing the quantity of the silver, if it be necessary. This operation is called quartation, and is preparatory to the parting; and even many authors extend this name to the operation of parting.

**QUARTZ.** A mineral of the flint genus, which is divided into five subspecies by Professor Jameson; namely, the amethyst, the rock-crystal, milk quartz, common quartz, and prase.

**QUICKLIME.** A hot caustic substance, employed in the composition of mortar for buildings; by farmers, as a manure; by bleachers, tanners, sugar-bakers, soap-boilers, and iron-masters, in the preparation of various manufactures; and also in medicine. Quicklime is obtained from chalk, marble, limestone, oyster-shells, &c. by expelling from them, by means of heat, the carbonic acid and water with which they are combined. The quantity of quicklime obtained from a ton of limestone, if weighed when hot from the kiln, is on an average, according to the experiments of Bishop Watson, 11 cwt. 1 qr. 4 lb. By exposure to the air also, a ton of quicklime acquires daily the additional weight of about one twentieth part of itself, for the first five or six days after it is drawn; and therefore, the earlier it is used the better. Quicklime, to be reserved for chemical or medicinal uses, should be kept in bottles well stopped.

**QUICK-MATCH.** A combustible preparation, formed of cotton strands, drawn into length, and dipped into a boiling composition of vinegar, saltpetre, and mealed powder. After this immersion, it is taken out hot, and laid in a trough, where some mealed powder, moistened with spirits of wine, is thoroughly

incorporated into the twists of the cotton, by rolling it about therein. They are afterwards taken out separately, drawn through mealed powder, and hung upon a line to dry. They are then fit for service.

**QUICKSILVER.** See **MERCURY.**

**QUILLS.** The largest feathers taken from the wings of geese, swans, crows, and other birds. The different qualities are denominated according to the order in which they are fixed in the wing; the second and third quills being the best for writing, as they have the largest and roundest barrels. Crow-quills are chiefly used for drawing. The goose-quills are those in general use for writing. These are cleansed and hardened by placing them one by one in a clear fire, so as to soften them merely, and then drawn under an iron edge, which nearly flattens them for the instant, but they immediately after return to their cylindrical figure.

**QUININE.** A vegetable alkali obtained from cinchona (bark.) It is prepared by the following process: a pound of bruised bark is boiled in about a gallon of water, containing three fluid drachms of sulphuric acid. A similar decoction is repeated with about half the quantity of liquid, and so on till all the soluble matter is extracted. The decoctions are then mixed together and strained, when powdered slaked lime is added in a proportion somewhat greater than necessary to saturate the acid; the precipitate that ensues, a mixture of quinine and sulphate of lime, is collected, dried, and boiled for some minutes in strong alcohol, which is then decanted while still hot, and fresh portions successively added for the repetition of the same operation, until it ceases to act on the residuum, which is then merely sulphate of lime. The different alcoholic solutions are then put into a vessel, and considerably evaporated; during which, and especially on cooling, transparent plates of quinine are deposited. It is very insoluble in water, and its taste is very bitter. It unites with the acids, forming crystallizable salts. The sulphate is of a dull white colour, silky and flexible: it is, like the alkali, soluble in alcohol; and burns away without leaving any residuum. M. Pelletier and Caventon state its component parts to be

Quinine . . . . .	100
Sulphuric acid . . . . .	10.9147

The acetate is remarkable for the manner in which it crystallizes. Its crystals are flat needles of a pearly lustre grouped in silky bundles, or in stars.

## R.

**RACE.** The canal along which the water is conveyed to and from a water wheel.

**RACK.** A straight bar, which has teeth or cogs similar to those on a toothed wheel.

**RADICAL.** That which is considered as constituting the distinguishing part of an acid, by its union with the acidifying principle, or oxygen, which is common to all acids. Thus sulphur is the radical of sulphuric acid.

**RADIUS.** In Geometry, the semi-diameter of a circle, or a right line drawn from the centre to the circumference. It is implied in the definition of a circle; and it is apparent, from its construction, that all the radii of the same circle are equal. The radius is sometimes called, in Trigonometry, the sinus totus, or whole sine.

**RAFT.** A float formed of an assemblage of pieces of timber fastened together, for the convenience of transporting them without dispersion; or for sustaining goods in transport; and sometimes for the saving of the lives of persons shipwrecked. A few years ago, Mr. Harrington took out a patent for a raft for transporting timber; the construction of which is described in the specification to be as follows:—The keel, stern-post, and lowest timbers of the ribs, are to be formed

and put together according to the usual way of constructing an ordinary ship. To form the bottom, balk timbers are to be laid together, side by side, lengthways of the vessel; and athwart these, others are to be closely laid, cutting their ends to suit the figure, then bracing the upper and lower timbers together. In this manner the lower parts of the vessel are to be formed, by packing the timbers crosswise closely, and connecting them by bolts and screws, leaving proper spaces open for slipping in the masts. In the upper part of this raft, suitable berths and cabins are to be provided for the navigators; the outside is to be planked all over, and caulked, pitched, and tarred in the usual manner; the masts and rigging are also to be of the ordinary kind. This account is undoubtedly descriptive of a method of constructing a good mercantile raft, but the novelty of the principle of its construction we do not discover.

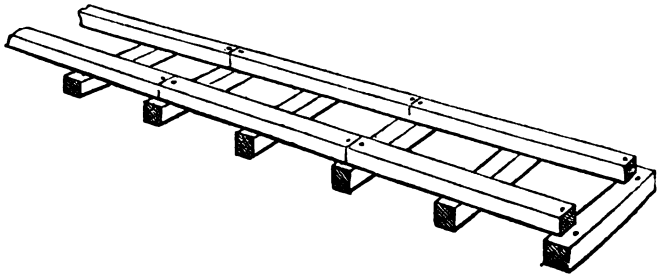
Much ingenuity has been exercised in the construction of life-rafts in cases of shipwreck, amongst which we may notice that of Mr. Canning, constructed of water-barrels and spars, so arranged that the parties on board are suspended on a platform high above the water to a horizontal yard-arm, preserved and supported in that position by cross spars, to which are attached the floating barrels.

**RAFTERS**, in Building, are pieces of timber, which, standing in pairs on the railing piece, meet in an angle at the top, and form, as it were, the ribs of the roof.

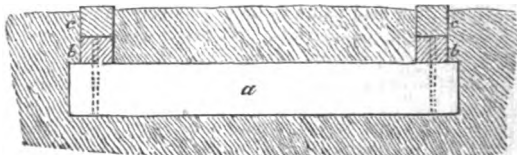
**RAGSTONE**. A species of blue stone with a sharp grit, employed for sharpening knives and coarse instruments upon. It is abundant in Kent, at Newcastle, in Northumberland, and at Rowley, in Staffordshire.

**RAILWAY**. The origin of railways it would be difficult to fix any precise date to. The laying down of wheel-tracks of some more cohesive material than ordinary earth, seems so obvious and natural as to render it extremely improbable that wooden ways in peculiar situations (especially in mines) were not brought into use before the period assigned to it by writers on the subject. From their statements it would appear, that the date of their primary existence was in the year 1670; at which time coal came to be extensively substituted for wood fuel in London and other populous districts. At that period the great mart for coal was Newcastle upon Tyne; and the transport of the mineral from the mines to the ships in the river became of great and increasing difficulty, owing to the wearing away of the road, by the constant traffic of the very numerous waggons, carts, and horses. Previous to the erection of these railways, it was no uncommon thing for the occupiers of the mines, to employ five or six hundred horses and carts each, in the same traffic. It therefore became an object of vast importance to adopt some plan of reducing the very great expense incurred in the keeping of so many horses and drivers, wear and tear of carts, and the making and repairing of roads. After giving the subject much consideration, wooden rails, consisting of straight pieces of timber, were laid down and embedded in the road. These were found so advantageous at Newcastle, that they were speedily copied in other mining districts, and remained in use for a considerable period of time. The mode of constructing these rude railways was as follows. After the ground had been levelled and smoothed, as in the formation of an ordinary road, sleepers, composed of large logs of wood, and cut into lengths corresponding with the breadth of the road, were laid across it at short distances, and firmly bedded into it, for the purpose of supporting and keeping fast the rails on which the waggon-wheels were to run. The rails were connected end to end, forming two continued lines, running in a parallel direction on each side of the road, and crossing the large logs at each of their extremities, which formed the foundation for them to rest upon, and to which they were nailed, or otherwise secured, to keep them in their places. The rails were of course very imperfect, and were rapidly worn away, or broken, by the continued friction of the wheels upon them. In order to repair or reconnect them when their continuity or evenness was destroyed, slips or pieces of timber of a smaller scantling were laid over the dilapidated portions; and the strength which the latter thus derived, led to the introduction of double rails throughout

the line; and this improvement was distinguished by the term of a "double-way," in contradistinction of the former plan, afterwards denominated the "single-way."



In the single-way above delineated, it should be observed that the ends of the successive rails necessarily met on a sleeper to which they were fastened; but owing to the continual concussions they were subjected to, not only by the loaded waggons, but by the feet of the draught horses, they soon became loosened, worn out, or otherwise deranged. By fixing another rail above the former, which might be of any length, and be fastened to it in any part, it not only much increased the strength of the whole, but defended the substructure from wear; while the upper, or covering rail when worn out might be renewed without materially disturbing the under. The double-rail also, being more elevated from the ground, admitted of a greater depth of cinders, or other hard substance, in order to form a more solid and durable road for the waggons and horses. The annexed diagram, which is designed to exhibit a cross section of the road, will make this matter clear. At *a* is one of the sleepers, which lie



about two feet apart across the road, throughout its entire length: *b b* show the ends of the under rails, which are cut of a uniform length, so as to rest upon three sleepers; so much constituted the single-way before delineated. At *c c* are the upper or covering rails, which may be of the length of the whole balk, and be fastened wherever convenient to the under rails; and this addition constituted it into a "double-way," which term might reasonably be supposed to imply a double road, instead of a single one. Railroads of the last described kind continued in use for many years in the collieries of the north of England; and a horse was found competent to draw three tons of coals upon them. The waggons used were nearly of the present construction; but their wheels of so small a diameter, as to be generally termed "rollera." At the declivities, significantly called *runs*, brakes were employed to retard the progress of the waggons. To avoid descending from the high banks near the river, high platforms, called *staiths*, were erected, projecting over the water. On to these staiths the waggons were run by a slightly inclined plane, and there discharged through apouts either directly into the holds of ships moored underneath, or into capacious intermediate reservoirs conveniently planned for the subsequent loading of ships.

In most cases the wooden railroads, from the mine to the place of shipment, were made so as to follow very nearly the undulations of the country over which they passed; excepting only here and there at very steep ascents; and for a long period of time no attempts were made to counteract the rapid descent of

the carriages down the declivities, except by means of brakes, which, depending wholly upon the strength and dexterity of the waggoners, often failed, and were productive of many sad accidents. When cast-iron wheels were first introduced, they were only used for the fore-axle, the wooden wheels being retained on the hind-axle, from the idea that the brake could only be applied effectively to the wooden wheels. At length it was contrived, by an extension of the lever, to apply a brake to the metallic; and then all the four wheels were made of iron. The next improvement was the substitution of iron rails for wood, which alone enabled the horse to take double his previous load.

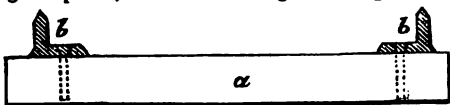
The adoption of cast-iron plates to cover and strengthen the wooden fabric, was the first application of metal to railways; and this was effected by the Colebrook-dale Company, at their iron works in Shropshire, in 1767. This information we derive from a published letter of the ingenious Hornblower, the contemporary of the celebrated Watt; wherein he says, "Railways have been in use in this kingdom time out of mind, and they were usually formed of scantlings of good sound oak, laid on sills or sleepers of the same timber, and pinned together with the same stuff. But the proprietors of Colebrook-dale Iron Works, a very respectable and opulent company, eventually determined to cover these oak rails with cast-iron, *not altogether as a necessary expedient of improvement, but in part as a well-digested measure of economy in support of their trade.* From some adventitious circumstances, (which I need not take time to relate,) the price of pigs became very low, and their works being of great extent, in order to keep the furnaces on, they thought it would be the best means of stocking their pigs, to lay them on the wooden railways, as it would help to pay the interest by reducing the repairs of the rails; and if iron should take any sudden rise, there was nothing to do but to take them up, and send them away as pigs. But these scantlings of iron (as I may call them) were not such as those which are now laid in some places; they were about five feet long, four inches broad, and one inch and a quarter thick, with three holes, by which they were fastened to the rails, and very complete it was both in design and execution. Hence it was not difficult, if two persons on horseback should meet on this road, for either to turn his horse out of the road, which, on the railways now introduced, would be attended with some serious doubt as to the consequences. *But it would be impossible on the best railways to afford that facility of travelling which we now enjoy on a spacious well-managed road.*" So able a man as Hornblower would never have hazarded this prediction, had the plans for locomotion on rails as now developed, been submitted to him as an engineer, for his opinion of their feasibility.

The introduction of metallic surfaces to wooden rails was, however, at first productive of serious evils, for the resistance of, or adhesion to the surface in descending inclined planes was thereby so much lessened, that the ordinary brake was found to be quite ineffective in counteracting the force of gravity. Recourse was therefore had to the double self-acting inclined planes, by which the surplus force of gravity of the load descending one plane, was employed to drag up the empty waggons on the ascending plane. As the acting principle of mechanism of this kind is so very simple and obvious, we shall not detain the reader by describing any of their details in their pristine state, but refer him to the matured plans of more recent times, which will be described hereafter in their proper place.

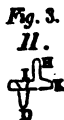
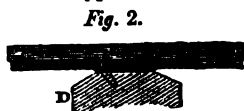
We now come to the period 1776, when cast-iron plates were used, not as coverings to wooden rails, but in the place of the rails themselves; such plates having cast to them an upright ledge, to keep the carriage wheels from running off them. These plates, being used by the waggons called trams, acquired, and have ever since been distinguished by the term "tram-plates." They were the subject of a patent granted to Mr. Carr, of the Sheffield Colliery, and were undoubtedly an important improvement, as from the date of the patent to the present time, they have been in constant requisition to an immense extent, both on the surface, and in mines. The form given to them, as used in the above mentioned colliery, is delineated in the following transverse section. *a* represents an oaken sleeper; *b b* the tram-plates of cast-iron, which are about six

feet long, and fastened down at each end and in the middle to three parallel sleepers. In situations where stone is less valuable than timber, blocks of that material are substituted.

The mode of fastening down tram-plates by bolts or spikes was found to be attended with several inconveniences, owing to the occasional projection of their heads, their becoming loose, and hence both the plates and bolts being frequently stolen, to the entire stoppage of the traffic upon the road. To remedy these evils, Mr. Charles le Caan, of Llanelly, in South Wales, contrived a mode of forming the plates, so that no bolting or nailing was requisite, but each plate



in succession fastened down the previous one. *Fig. 1* represents a plan of the junction of two plates, placed on a stone sleeper *D*; and *Fig 2* shows a longitudinal section of the same. The plates are joined by a dove-tailed notch and tenon, and an oblique plug is cast on each plate, which is let into the stone sleeper; but for the advantage of taking up the plates to repair any defect, there are plates at every thirty yards, with perpendicular plugs; such plates are called stop-plates. The diameter of the plug near the shoulder is one inch and three quarters, at the point one inch, its length two inches and a half, and its obliquity, shown in *Fig. 2*, about eight degrees. A small groove in the whole length of the exterior of such plug is made to allow the water in the hole to expand in freezing; and it also serves to admit a wire to draw a broken plug out by it. The holes for the plugs should be cut to the depth of three inches by a standard gauge of cast-iron, and countersunk so as to allow the end of the plate to bed firmly on the block which supports it. *Fig. 3* is one of the



ends of a tram-plate, in which *H* shows the flange or upright edge; *I* the flat part or sole, in which the wheels of the waggon run; *D* one of the plugs; and *K* a projection behind, to render the plates firmer upon the blocks. The usual length of one plate is three feet; the flanch *H* is one and a half inch high; the sole, or bed, three and a half, or four inches broad, and three-fourths of an inch thick; but these dimensions are varied according to circumstances. The most approved weight has been forty-two pounds for each plate; the ends from which the plugs project, under which the tenons and notches are made, should be a quarter of an inch thicker than the other parts of the plate. The weight of the blocks or sleepers should not be less than about 120 pounds each; and some kinds of ground will require heavier. In this method the wheels of the waggons cannot be obstructed by the heads of the nails rising above the surface, and the blocks are not disturbed by fixing the plates; and when repairs are necessary, the plates must be formed for the purpose. When tram-plates are fixed by spikes to stone sleepers, there is some difficulty in keeping the joint even and in its place; but it seems to be successfully obviated by using a saddle-pin to receive the ends of the nails at the joints, an improvement which was introduced by Mr. Wilson on the Troon tramroad.

Tramroads are much esteemed in Wales; and in consequence of using them, it is found desirable to divide the pressure upon the rails as much as possible; hence, small carriages are used, and these lead to small wheels, so that the effect of a given power is not above half what it ought to be; and yet the enormous increase of railroads in Wales renders it evident that some benefit is received from adopting this system of conveyance. In 1791, there was scarcely a single railway in South Wales; and in 1811, the complete railroads connected with

canals, collieries, &c. in Monmouthshire, Glamorganshire, and Caermarthen-shire, amounted to nearly 150 miles in length, exclusive of under-ground ones, of which one company in Merthyr Tydvil possessed about thirty miles; since which period the lines have been extended to, at the least, five hundred miles.

It now becomes proper to introduce some notice of *edge rails*, the use of which is so generally and justly preferred to the tram plate. Their origin it would be difficult to trace with any precision; and it is a question of so little moment, as to be hardly worth the trouble of investigation. Some of the wooden rails partook of the usual shape, especially when capped with a plate of iron: hence a transition to more judicious forms and more permanent materials was easy.

The earliest complete edge rail which we know of was made of *cast-iron*, in 1789, by Mr. Jessop, at Loughborough, the upper surface of which was flat, and the under of an elliptical shape. But this appears to have been so little known to engineers, that we find Mr. Benjamin Wyatt making use of a cast-iron edge rail in 1800, and imagining himself to be the inventor. The form of his rail was indeed quite original, and ought not therefore to be omitted in this sketch. It is thus described by himself:—

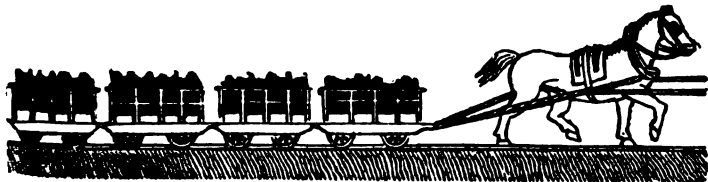
“The rail hitherto made use of in most railways is a flat one, 3 feet in length, with a rib on one edge, to give it strength, and to prevent the wheels, which have a flat rim, from running off. Observing that these rails were frequently obstructed by stones and dirt lodging upon them; that they were obliged to be fastened to single stones or blocks, on account of their not rising sufficiently above the sills to admit of gravelling the horse path; that the sharp rib standing up was dangerous for the horses; that *the strength of the rail was applied the wrong way*; and that less surface would produce less friction: led me to consider if some better form of rail could not be applied. The *oval* presented itself as the best adapted to correct all the faults of the flat rail, and I have the satisfaction to say that it has completely answered the purpose in a railway lately executed for Lord Penrhyn, from his lordship’s slate quarries in Caernarvonshire to Port Penrhyn, the place of shipping. The wheel made use of on these rails, has a concave rim, so contrived in its form, and the wheels so fixed upon their axes, as to move with the greatest facility on the sharpest curves that can be required.” In the annexed section, *a* represents



the rail, which is 2 inches deep and  $1\frac{1}{2}$  inch thick horizontally; the lower part, *b*, is cast to each end of the rail, 3 inches long, to let into the sills, which have a dove-tailed notch to receive them. The advantages of this form were said to be, that no dirt can lodge upon it; that it is strong for its weight, and calculated to resist both the lateral and perpendicular pressure; that it must occasion but little friction; that it may be placed on the sills so as to admit a sufficient quantity of gravel to cover them, and present

no danger to the horses. They were cast 4 feet 6 inches long, and weighed 36 pounds each.

The Penrhyn railway is six miles and a quarter in length, divided into five stages. It has three-eighths of an inch fall in a yard, with three inclines; was begun in October 1800, and finished in July 1801. The annexed sketch



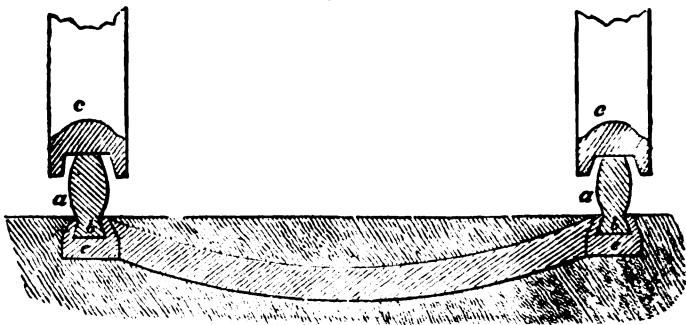
shows the kind of waggons that were used on this railway, twenty-four of which, containing 24 tons, were drawn by two horses (one stage) six times a day; which is 144 tons per day, drawn  $6\frac{1}{2}$  miles per day. This quantity of work was



## 378 FIRST LOCOMOTIVE ENGINE BY TREVITHICK & VIVIAN.

previously performed by 144 carts, and 400 horses: so that *ten* horses will by means of this railway do the work of *four hundred*!

It was however found that the oval-formed rail had a tendency to wear the concave rims of the wheels very fast into hollows, which fitted so tight upon the rail as to create great friction, and render it necessary to change the wheels very often. It was accordingly proposed to substitute for them a rail and wheel



represented in the annexed cross section: *a* is the rail, *b* the dovetail, *c* the lower ends of the wheels, and *e* the sills, now made of cast iron.

### SECOND ERA.

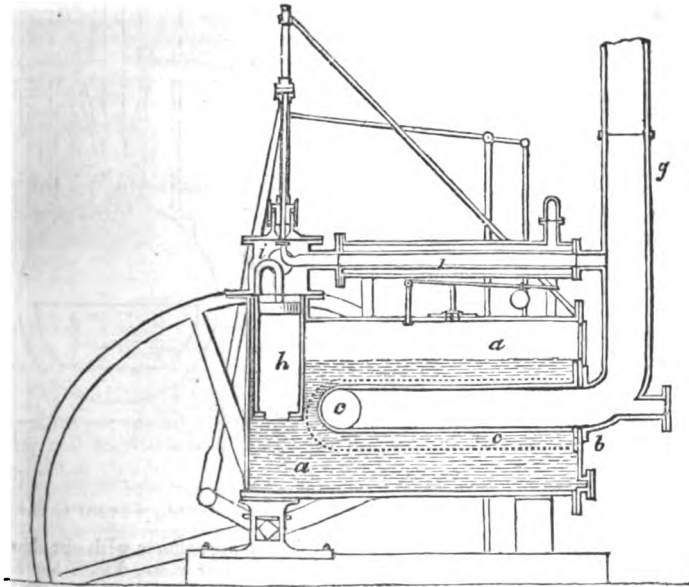
To Trevithick and Vivian, who were engineers at Camborne, in Cornwall, belongs we believe the honour of having invented and carried into practice locomotive engines. This single event forms an era, not only in mechanical science, but also in our social relations; as it is calculated to bring about a more extensive and beneficial change than almost any other event on the page of history, by placing the arts, sciences, knowledge, conveniences, comforts, manufactures, and produce, peculiar to each remote place or district within the reach of all.

We should not omit to notice, that the possibility of applying the power of the steam engine was mentioned by several mechanics, soon after it was brought into a practicable form by Savery, Newcomen, and others, in the early part of the last century; and towards the latter part (1784), the celebrated James Watt mentioned the subject in his specification of that date, seemingly with the view of recording himself as the inventor; but he never built a steam carriage; and the machine which he suggested under his general patent, was designed for the common road. "A carriage for two persons, might (he observed) be moved with a cylinder of seven inches in diameter, when the piston had a stroke of one foot, and made sixty strokes a minute." In a note to a late edition of Dr. Robinson's mechanical Philosophy, Mr. Watt states: "I soon relinquished the idea of constructing an engine on this principle, from being sensible it would be liable to some of the objections against Savery's engine, viz. the danger of bursting the boiler, and also that a great part of the power of the steam would be lost, because no vacuum was formed to assist the descent of the piston." This extract affords clear evidence of two important facts. The first, that Mr. Watt did not entertain the idea of applying his crude scheme to railways, although there were many in active operation in the North of England, and some few in Wales. The second fact is, that Mr. Watt acknowledged the incompetency of his own scheme to effect the object designed.

In the formidable qualities which had excited the fear of Watt and others, Trevithick and Vivian perceived those very properties which fitted it to become the actuating principle of their mechanism. Above all other considerations which swayed them in the preference of steam of a high temperature, was the power it gave of dispensing with the use of the condenser altogether; a part

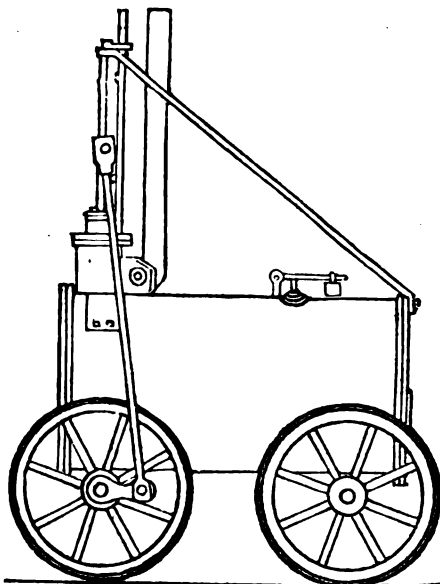
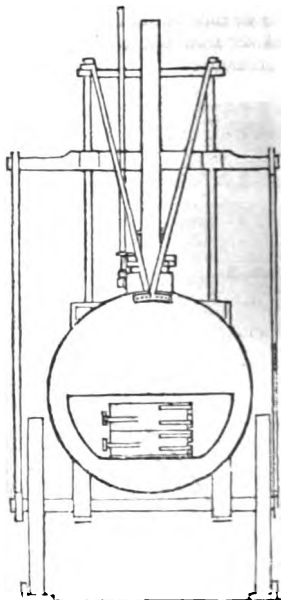
which, from its cumbrousness, and the difficulty of supplying it with water, rendered it far inferior even to Newcomen's imperfect apparatus for locomotive purposes.

Being unprovided with an authentic drawing of Trevithick and Vivian's locomotive, we will endeavour to explain its arrangements with such diagrams as we have in our possession. The annexed, we are informed, is a sectional sketch from one of their engines, containing the same leading features as their locomotive.

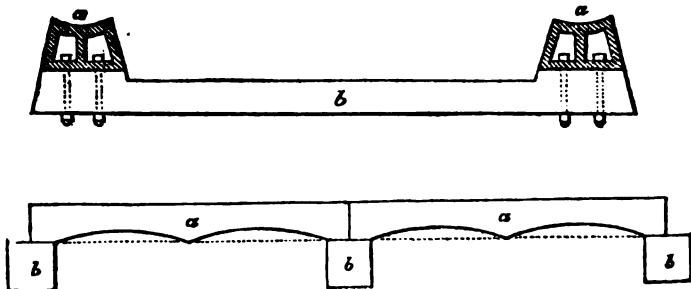


At *a a* is a cylindrical boiler, with a fire door at *b*, at one end of the cylinder; *c c* is the fire-place, from which proceeds the principal flue, the parts being shown by dots, as they are supposed to be situated on one side of the vertical plane, through which our section is made; the flue, therefore, is turned at the circle *e*, then recurved and continued to the chimney *g*. This arrangement of furnace and flue within the boiler has been ever since distinguished by the name of its inventor, Trevithick, and has been more used than any other, on account of its economy in the consumption of fuel. The lower part of the working cylinder *h* is immersed in the boiler, and the upper has a jacket, around which the fresh hot steam circulates freely, so that no loss of power can be sustained by the cooling influence of the air upon the cylinder, as was previously the case. Above the cylinder is the four-way cock *i*, for admitting and discharging the steam alternately; in the latter operation the waste steam was discharged along a pipe, *j*, into the chimney, which, by increasing the draught through the fire, augments the production of steam, and gets rid of the nuisance of the waste steam, in a manner so desirable as to render it now indispensable. The upper end of the piston rod is furnished with a cross head, which is placed in a direction at right angles to the length of the boiler, and parallel to each other. To the ends of this cross head are joined two connecting rods, the lower ends of which work two cranks, fixed in the extremities of the axis which carries the running wheels, the axis extending across and beneath the boiler, and immediately under the centre of the steam cylinder. This arrangement is shown in *Fig. 1* of the following diagrams, extracted from Mr. Gordon's *Treatise on "Elemental Locomotion,"* which states it to be an end elevation

of Trevithick and Vivian's locomotive engine; and *Fig. 2* a side elevation of the same. • Mr. Gordon has, however, omitted the chimneys, and has shown the eduction pipe as discharging the steam directly into the atmosphere.

*Fig. 2.**Fig. 1.*

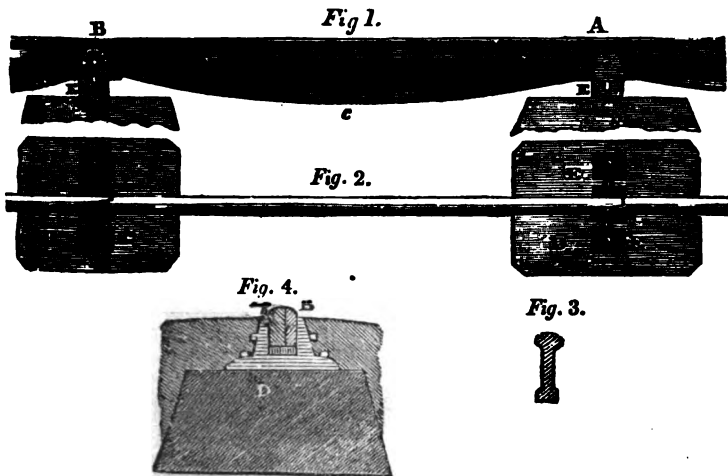
The next invention which we have to notice, in accordance with our chronological order, is that of an improved cast-iron rail or plate, which has proved in numerous situations to be highly useful; it was patented by Mr. J. Woodhouse, of Ashby-de-la-Zouch, in 1803. The specification describes various modifications of the plan, showing its application to gravelled roads, paved roads, or streets, and to railways. But the following diagram will suffice to show its application to the latter object, and its adaptation to the other objects may be as readily conceived. At *a a* is the rail or plate, the upper surface of which is made concave, as shown in the section in *Fig. 1*. The



length of these rails or plates is shown at *a a* in the elevation *Fig. 2*, and the mode of supporting and fastening their ends on two bearers or sleepers *b b b*. The bearings may be made of timber, stone, or cast-iron or wood piles; and the plates fixed by screw or cotter bolts. The road is to be made even with

proper road materials, and the rails will then, the patent states, be immovable. It was likewise intended to use the said hollow rails or plates as water-conduits or gutters, to which object they have been frequently and are now applied in many parts of London and elsewhere. Indeed, the design is so complete, as to adapt itself, with slight alterations, to many situations and purposes.

The improvements effected on the Penryn railway before mentioned naturally led to ameliorations in the structure of similar works elsewhere, which was



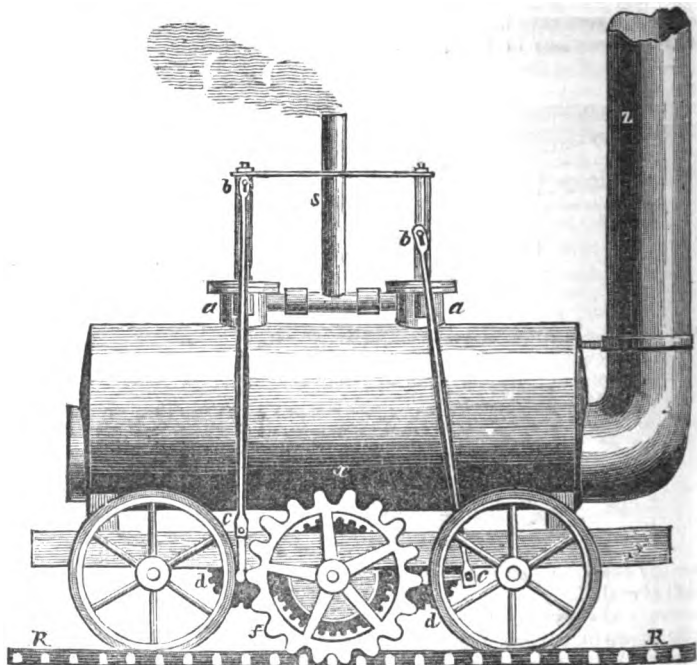
especially observable on the banks of the Tyne and Wear. The expense of the transit of coals forms so considerable a proportion of their money cost, that the owners are always alive to any decided saving that may be effected therein. In the engravings above, *Fig. 1* represents a side view, *Fig. 2* a plan, and *Fig. 3* a cross-section of a cast-iron edge-rail, of the form which has been extensively adopted in the districts above mentioned. The waggons run upon the rounded edge of the rail, which is smooth, and laid as evenly and regularly as possible. The length of these rails is usually three feet, with a depth of about four inches and a half in the middle, and breadth of the top two inches; but in some railways the rails are four feet long. The ends of the rails meet in a piece of cast-iron, called a chair (see *Fig. 4*), and the chairs are fixed to stone blocks or sleepers, with a broad base, and weighing from one and a half to two hundred weight. These are firmly bedded in the ground, and adjusted to a proper plane for the road before the chairs are connected to them. The goodness of the road of course depends much on fixing the sleepers in a sound, firm manner. In *Fig. 1* the side view of the rail C is shown, supported at the extremities A B by cast-iron chairs E E, which rest on the stone blocks, or sleepers, D D. *Fig. 2*, the plan, shows the scarf joints, where the ends of the rails meet in the iron chairs E E. *Fig. 3*, the cross section of the rail taken at C, in *Fig. 1*, which is the middle of its length. *Fig. 4* is a cross section at B, through the joint chair and supporting blocks.

Up to this period in the history of railways, it does not appear that any other power of draught or propulsion was employed but that of horses, except, occasionally, of fixed engines at inclined planes.

In the year 1811, a patent was taken out by Mr John Blenkinsop, coal viewer, of Middleton, in Yorkshire, for "certain mechanical means by which the conveyance of coals, minerals, and other articles is facilitated, and the expense attending the same rendered less than heretofore." The specification of this patent informs us that it consists of the application of a rack or toothed rail, laid down on one side of the roadway from end to end. Into this rack a

toothed wheel is worked by the steam-engine; the revolution of which wheel produces the necessary motion, without being liable to slip in descending a steep inclined plane.

The accompanying figure will convey to our readers an idea of Mr. Blenkin-

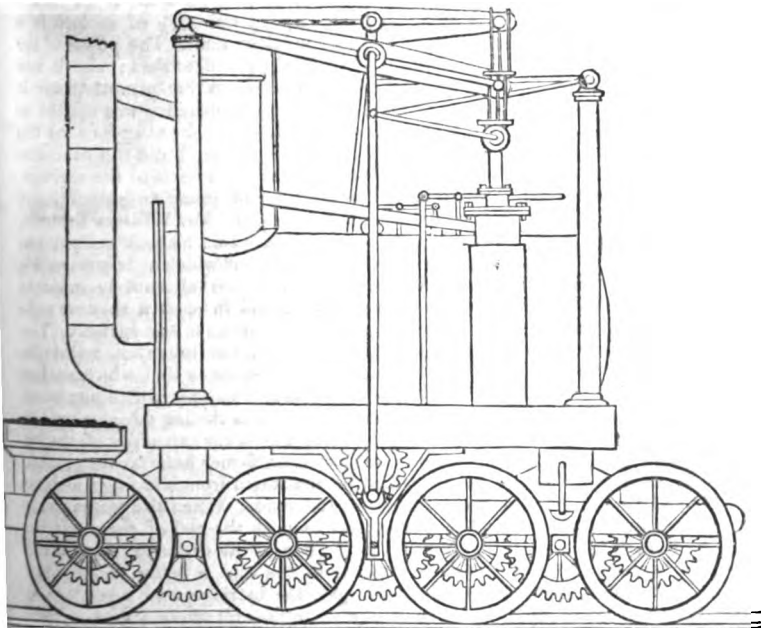


sop's plan. The boiler *x* is placed on a wooden or cast iron frame *y*. Through its interior passes a wrought-iron tube, of sufficient diameter to hold the fire and grate; this tube is carried out at the farther end of the boiler, when it is bent upwards, and continued sufficiently high to form the chimney *z*. *a a* are two working cylinders fixed in the boiler, and which work in the usual way; the piston rods are connected by cross heads to the connecting rods *b b*. These connecting rods are brought down on each side of the boiler, and there joined to the cranks *c c*, (there being corresponding cranks on the other side of the machine,) which are placed at right angles to each other; consequently the two cranks on the first shaft are horizontal, and at their greatest power, at the time the other two are passing the centre. Upon these shafts are fixed (under the boiler) two small toothed wheels, which give motion to a larger toothed wheel fixed upon an intermediate axis. A toothed wheel *f* is firmly keyed to the end of the same and revolves with the intermediate wheel. The teeth of *f* correspond with, and work into a rack *R R*, stretched along one side of the railway. Motion, therefore, is given by the pistons to the wheels *d d*, which they communicate to the cog-wheel *f*; a progressive movement being given to the carriage by the teeth of *f* taking hold of the rack.

The communication of the pressure of the steam upon the piston through the connecting rod and cranks, it is said, produced great noise, and in some parts of the stroke great jerks, each cylinder alternately propelling or becoming propelled by the other, as the pressure of the one upon the wheels become greater or less than the pressure of the other; and when the teeth became worn, they produced a rattling noise. Mr. Galloway states that several of these engines were constantly employed in drawing coal-waggons between Middleton

Colliery and Leeds; and with reference to their effectiveness, the following particulars were given by Mr. Blenkinsop in reply to queries put to him by Sir John Sinclair. He stated that his patent locomotive engine, with two eight-inch cylinders, weighs five tons; consumes two-thirds of a hundred weight of coals, and fifty gallons of water per hour; draws twenty-seven waggons, weighing ninety-four tons, on a dead level, at three and a half miles per hour; or fifteen tons up an ascent of two inches in the yard; when lightly "loaded" it travels ten miles an hour, does the work of sixteen horses in twelve hours, and costs 400*l*.

In the following year, 1812, Messrs. William Chapman, of Durham, and E. W. Chapman, of Wallsend, Northumberland, took out a patent for "a method or methods of facilitating the means, and reducing the expense of carriage on railways and other roads;" which they describe as chiefly consisting in the use of a chain, or other flexible and continuous substance stretched along the road to be travelled, properly secured at each end, and at suitable intervals; and in the application of this chain round, or partially round a grooved barrel or wheel, in such manner as not to slip when this grooved wheel, which is fixed upon, before, or behind a carriage containing the motive power, shall be put in motion by that power, so that by the revolution of the grooved barrel round its axis, either one way or the other, it shall necessarily draw the said carriage, and any others which may be attached to it, within its power of action. As the carriage containing the motive power, when thus loaded, may be too heavy in some instances for the existing iron or wooden rails, if it rested on four wheels only, Messrs. Chapman proposed to use six or eight wheels, in order that they

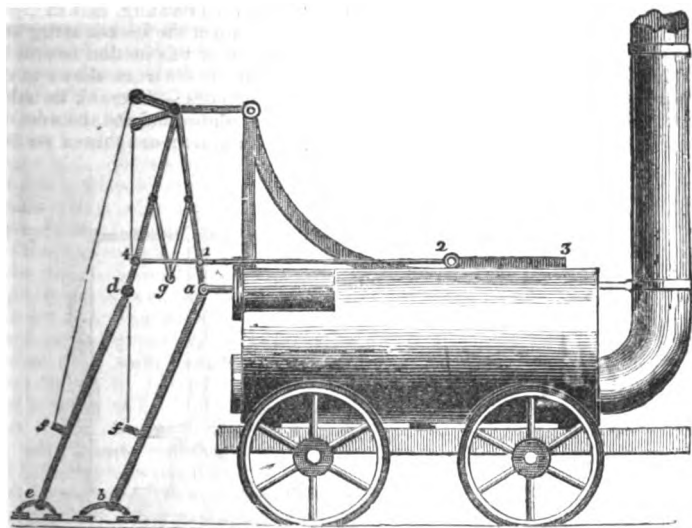


might more freely move round curves in the road, and that the weight might be more distributed thereon; the pressure being thus reduced upon each bearing point, in the inverse proportion of the number of wheels. The means adopted by the patentees for carrying their invention into effect, are described at considerable length, with explanatory drawings, in their specification; but as Mr. Wood informs us that the application of it failed at the Heaton Colliery, where

it was for a time put into practical operation, and as the details of it would occupy too large a space in our pages, if inserted, we shall refer the reader to the enrolled document for them. The cause of the failure just mentioned is stated to have been owing to the waste of power arising from the excessive friction of the chain. There are one or two incidental observations in the specification which ought not perhaps to pass unnoticed. Allusion is made to the possibility of employing *inflammable gas* as the motive power, which, most of our readers are aware, was a few years ago carried into effect by the ingenious Samuel Brown. We also remark, although it is of little moment, that the specification contains the first proposition we have met with for employing the common winnowing machine to force a current of air under the fire-place. The annexed engraving exhibits an elevation of one of the locomotive engines of Messrs. Chapman, which was employed on the Heaton Colliery. The boiler consists of a large cylinder, of the Trevithick kind, with the furnace and a double or return flue passing through it to the chimney, situate on one side of the fire door; opposite to which is a chest containing the fuel of supply. The steam chamber is a large vertical cylinder, from which proceeds laterally a pipe to conduct the steam to two vertical cylinders, fixed on either side of the boiler. The motion of the piston rods actuated two vibrating beams, to which were appended two connecting rods, whose lower extremities worked two revolving cranks, carrying on their axis, spur gear, which, through the medium of a train of toothed wheels, shown, gave simultaneous motion to all the running wheels. The weight of this engine, with its water and fuel, we are informed was six tons; and it was set to work in December 1812, upon the railway leading from Mr. J. G. Lambton's collieries to the river Wear. It drew after it 18 loaded coal waggons, weighing 54 tons, up a gentle ascent rising  $\frac{1}{8}$  of an inch to a yard (or 46 feet in a mile) at the rate of four miles an hour. The power of the engine was applied to the running wheels as already described; and it was found that their resistance to slipping upon the rails was the utmost power it could exert in drawing waggons after it, which in this instance was carried to the extreme; for although the friction was equal to the drawing forward the train of eighteen waggons, *after they were fairly in motion*, it did not overcome their *vis inertia* until after a considerable *slipping* of the wheels of the carriage.

We now come to the description of a machine of great singularity, and which strongly attests the ingenuity of the contriver, Mr. William Brunton, of the Butterly Iron works, in Derbyshire, and for which he took out patents. It consists in a curious combination of levers, the action of which nearly resembles that of the legs of a man in walking, whose feet are alternately made to press against the ground of the road or railway, and in such a manner as to adapt themselves to the various inclinations or inequalities of the surface. The following engraving represents this engine, which the inventor called his "MECHANICAL TRAVELLER." The boiler is nearly similar to that which we last described. The cylinder *a* is placed on one side of the boiler; the piston rod is projected out behind horizontally, and is attached to the leg *ab* at *a*, and to the reciprocating jointed bent lever above; at the lower extremity of the leg *ab* feet are attached by a joint at *b*; these feet lay a firmer hold on the ground, being furnished with short prongs, which prevent them from slipping; and are sufficiently broad to prevent their injuring the road. When the piston rod is projected out from the cylinder, it will tend to push the end of the lever, or leg *a*, from it, in a direction parallel to the line of the cylinder; but, as the leg *ab* is prevented from moving backwards by the end *b* being firmly fixed upon the ground, the reaction is thrown upon the carriage, and a progressive motion given to it, and this will be continued to the end of the stroke. Upon the first reciprocating lever is fixed at 1, a rod 1 2 3 sliding horizontally backwards and forwards upon the top of the boiler; from 2 to 3 it is furnished with teeth, which work into a cog-wheel, lying horizontally; on the opposite side of this cog-wheel a sliding rack is fixed similar to 1 2 3, which, as the cog-wheel is turned round by the sliding rack 2 3, is also moved backwards and forwards. The end of this sliding rod is fixed upon the other reciprocating lever of the leg *de* at 4. When, therefore, the sliding rack is moved forwards in the direc-

tion 3 2 1, by the progressive motion of the engine, and when the piston rod is at the farthest extremity of the stroke, the leg *d e* will be brought close to the engine; the piston is then made to return in the opposite direction, moving with it the leg *a b*, and also the sliding rack 1 2 3; the sliding rack acting on the tooth wheel causes the other sliding rod to move in the opposite direction, and with it the leg *d e*. Whenever, therefore, the piston is at the end of the stroke, and one of the legs is no longer of use to propel the engine forward, the



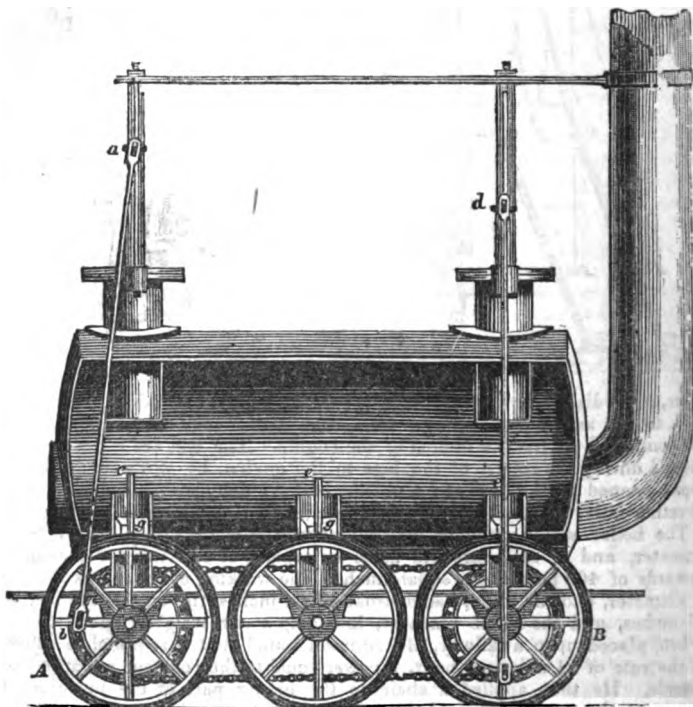
other, immediately on the motion of the piston being changed, is ready, in its turn, to act as an abutment for the action of the moving power to secure the continued progressive motion of the engine. The feet are raised from the ground during the return of the legs to the engine, by straps of leather or rope fastened to the legs at *ff*, passing over friction sheaves, movable in one direction only, by a ratchet and catch, worked by the motion of the engine.

The boiler was a cylinder of wrought iron, 5 feet 6 inches long, 3 feet in diameter, and of such strength as to be capable of sustaining a pressure of upwards of 400 pounds per square inch. The working cylinder was 6 inches in diameter, and the piston had a stroke of 24 inches, the step of the feet was 28 inches, and the whole machine, including water, weighed about 45 cwt. When placed upon a railway, Mr. Brunton found that it required to move it at the rate of  $2\frac{1}{2}$  miles per hour, a power equal to the constant pressure of 84 pounds. He then applied a chain to the hinder part of the machine, by which as the machine moved forward, a weight was raised at the same time and rate; and he found that with steam equal to 40 or 45 lbs. pressure upon the square inch, the machine was propelled at the rate of  $2\frac{1}{2}$  miles per hour, and raised 112 lbs. at the same speed; thus making the whole power 896 lbs., at  $2\frac{1}{2}$  miles, which, at 150 lbs. the horse power, is equal to about six horses; but the machine was only designed to insure 4 horses' power, and to work upon a railway rising one in thirty-six.

To get rid of the cumbrous wheels and pistons, and avoid the jerks and concussions consequent upon Mr. Blenkinsop's arrangement, we find Mr. Ralph Dodd and Mr. George Stephenson taking out a joint patent "for various improvements in the construction of locomotive engines," which was dated Feb. 28, 1815. It consisted of the application of a pin upon one of the spokes of the running wheels that supported the engine; the lower end of the connecting-rod being attached to the pin, and the upper end to the cross-head of



the piston rod, worked up and down by the piston. (The following engraving serves to explain this invention, although it belongs to the patented improvements subsequently introduced by Mr. Losh, in conjunction with Mr. Stevenson; Mr. Dodd's previous invention being combined therein.)  $ab$  represents the connecting-rod, the end  $a$  attached to the cross-head, and the end  $b$  to one of the spokes of the wheel; in like manner the end  $d$  of the other connecting-rod is attached to the beam of the other piston, and the lower end to a pin fixed in the spokes of the wheel B. By these means the reciprocating motion of the piston and connecting-rod is converted, by the pin upon the spokes acting as a crank, into a rotatory motion, and the continuation of this motion secured by the one pin or crank being kept at right angles to the other as shown in the drawing. To effect this, the patentees had two methods;—to crank the axles, on which each of the wheels were fixed, with a connecting-rod between, to keep them always at the angle with respect to each other; or to use a peculiar



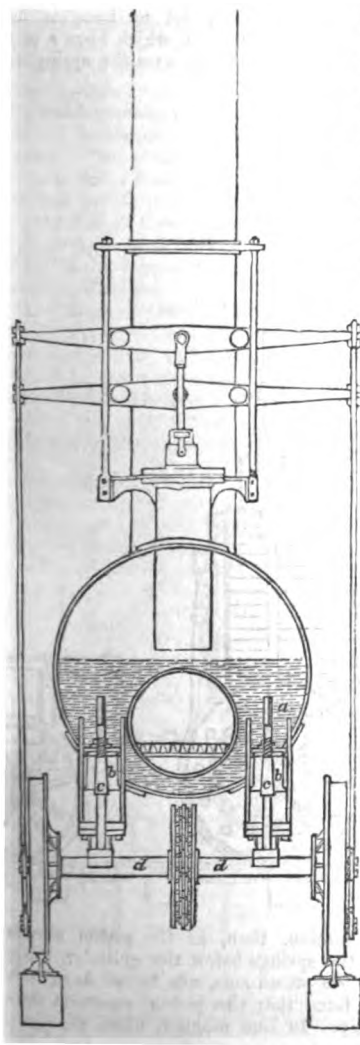
sort of endless chain passing over a toothed wheel on each axle. This endless chain consisted at first of one broad and two narrow links, alternately fastened together at the ends with bolts; the two narrow links were always on the outside of the broad link; consequently, the distance they were separated laterally would be equal to the breadth of the broad link, which was generally about two inches, and their length three inches. The periphery of the wheels fixed upon the axles of the engine, was furnished with cogs, projecting from the rim of the wheels (otherwise perfectly circular and flat) about an inch or an inch and a half. When the wheel turned round, these projecting cogs entered between the two narrow links, having a broad link between every two cogs, resting on the rim of the wheel; these cogs, or projections, caused the chain to move round with the wheel, and completely prevented it from slipping round upon the rim. When, therefore, this chain was laid upon the two toothed wheels, one wheel could not be moved round without the other moving round with

it, and thus secured the proper angles to the two cranks. This mode of communicating the action of the engine from one wheel to another, is shown in the drawing, the wheels A and B having each projecting cog-wheels, round which the endless chain passes. When the chain got worn by frequent use, or was stretched, so as to become too long, one of the chairs of the axles could be moved back to tighten it again, until a link could be taken out, when the chair was moved back again to its former situation.

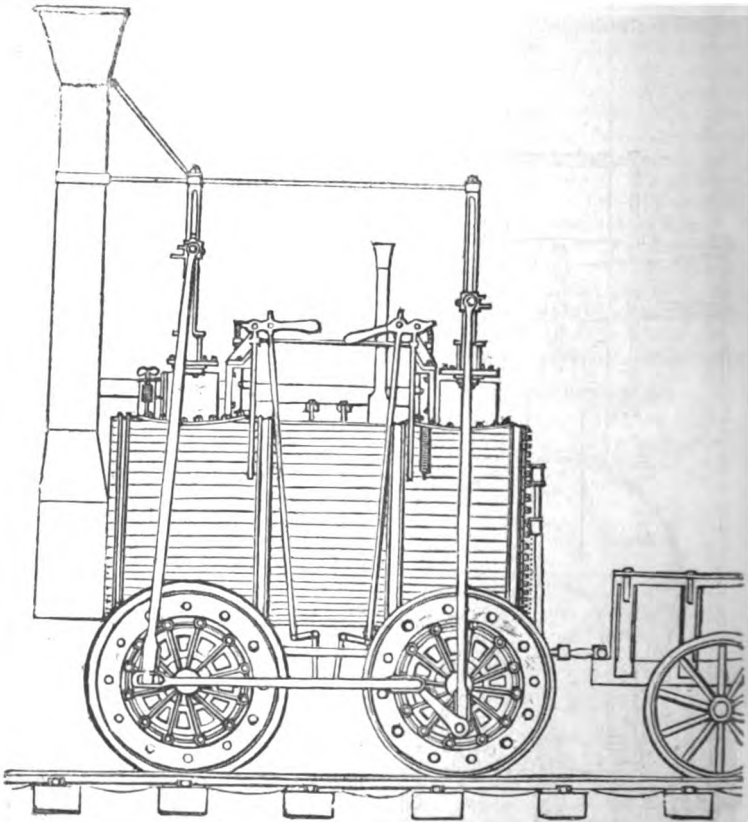
In the following year, 1816, a joint patent was obtained by Messrs. Stevenson and Losh, of Newcastle, for a variety of improvements in the carriages, wheels, rails, &c. of a railway. In that part which relates to locomotive engines, the very singular proposition is made of "sustaining the weight or a part of the weight of the engine, upon pistons moveable within cylinders, into which the

steam or water of the boiler is allowed to enter, in order to press upon such pistons; and which pistons are, by the intervention of levers and connecting-rods, made to bear upon the axles of the running wheels of the engine." The annexed section of a locomotive engine, exhibits the application of the "Steam-springs," as they were called. At *aa* are the steam-cylinders, containing the floating pistons *bb*, connected with rods, *cc*, the ends of which rest upon the brasses of the axles of the wheels *dd*. "These pistons, pressing equally on all the axles, cause each of the wheels to press with an equal stress upon the rails, and to act upon them with an equal degree of friction, although the rails should not all be in the same plane; for the bearing brasses have the liberty of moving in a perpendicular direction in a groove or slide, and carrying the axles and wheels along with them, free the wheels to accommodate themselves to the inequalities of the railway. The objects of these floating pistons are, to prevent the engine from receiving shocks, and preserve a steadiness of motion; the inventors considering, that by acting on an elastic fluid, they produce the desired effect "with much more accuracy than could be obtained by employing the finest springs of steel to support the engine." A longitudinal section of this locomotive engine is given in the preceding figure, in the description of Dodd and Stephenson's improvements, which it equally illustrates.

These locomotive engines were long in use at Killingsworth Colliery, near Newcastle, and at Hetton Colliery, on the Wear; so that their advantages and defects have been sufficiently submitted to the test of experiment. "The principal objections (in the opinion of Mr. Galloway), consist in the difficulty of surmounting even the slightest



ascent; for it has been found that a rise of only one-eighth of an inch in a yard, or 18 feet in a mile, retards the speed of one of these engines in a very great degree; so much so, indeed, that it has been considered necessary, in some parts where they are used, to aid their ascent with their load by fixed engines, which drag them forward by means of ropes coiling round a drum. The steam cylinders below the boiler were found very defective, for in the ascending stroke of the working piston, they were forced inwards by the connecting-rod pulling at the wheel in turning it round, and in the descending stroke the same pistons were forced as much outwards: this motion or play rendered it necessary to increase the length of the working cylinder as much as there was play in the lower ones, to avoid the danger of breaking or seriously injuring the top and bottom of the former by the striking of the piston when it is forced too much up or down. As our meaning may not be fully comprehended without elucidation, let us imagine the cylinder of a common beam engine to be set upon springs which have a play of one foot; the weight of the cylinder, when at rest, depresses the spring six



inches; but if the engine be put in motion, then, as the piston ascends and gives motion to the machinery, the springs below the cylinder, being, as it were, the abutments upon which the steam acts, are forced downwards against their seat with precisely the force that the piston exerts in overcoming the resistance of the machinery. In like manner, when the piston

descends, as much weight or pressure will be taken off these springs by the same means : the cylinder would, therefore, vibrate or dance upon the bearing springs ; and as the motion which it thus obtains is the reverse of the motion then given to the piston, the length of the cylinder should be greater to allow for the extreme vibration to which it is liable. A quantity of steam would, therefore, be lost in filling up this extra length of the cylinder at each stroke. This would also happen if the cylinder were *fixed*, as usual, and the carriages of the crank and fly-wheel supported upon springs ; and this arrangement would then be exactly the same, in principle and effect, as the parts of the locomotive engine to which we now allude."

The engraving on the preceding page represents one of the engines made for the Kirkintilloch and Monkland Colliery Railway, by Messrs. Murdoch and Aitken of Glasgow. The working of these engines gave, it is said, very high satisfaction to the proprietors, as performing more work than the engineers undertook they should execute. As there appears to be nothing in the arrangement of the parts which was not previously known, we can only attribute the high character these engines attained, to superior workmanship—and the clothing of the engine in a wooden casing, to prevent the waste of heat. It affords a good example of the old fashioned locomotives, and shows a peculiar mode of coupling the wheels. The connecting rod between the two wheels has a ball and socket joint at each end, making universal joints. The wheels have a play of about one inch to allow for turning in the sharp curves of the line. The cylinders are 10½ inches diameter each, and the stroke two feet, pressure of steam 50lbs. The average speed of these engines was 6 miles per hour, which is quite adequate for the purposes of a colliery. They were the first locomotive engines made in *Glasgow*.

The improvements in the engine or carriage wheels proposed by Messrs. Stephenson and Losh, in their patent of 1816, consisted in forming the spokes of malleable iron, and uniting them in the sand by casting the ring and nave to them. In some cases, they made the "spokes of cast iron, with hoops, tires, or rods of malleable iron."

Fig. 1 is a side view of the wheels, with wrought-iron arms. *a a a* show the arms cast in the nave, and dropped into mortice holes made in the rim, which

Fig. 2.

Fig. 1.

Fig. 3.

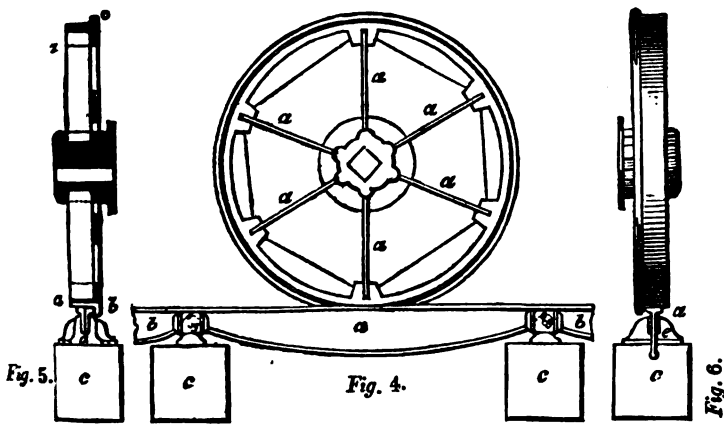


Fig. 5.

Fig. 4.

Fig. 6.

Fig. 7.

are dovetailed, to suit the dovetailed ends of the arms *a a a*. The arms are heated red hot previous to dropping them into the holes, in order to cause them to extend sufficiently for that purpose, for when cold they are too short, owing to the property which iron possesses, of expanding on the application of heat, and of contracting again to its former dimensions on cooling down to the same temperature from which it was raised; the arms, therefore, on cooling, are drawn with a force sufficient to produce a degree of combination between their dovetailed ends and the mortices of the rim, which prevents the possibility of their working loose; they are afterwards keyed up; the mortice holes are also dovetailed, from the tail side of the wheel (*a a*, *Fig. 2.*) to the crease side (*b* in the same figure).

*Fig. 2* is a cross section through the centre of the wheel, with wrought-iron arms.

*Fig. 3* is an end view of *Fig. 2*.

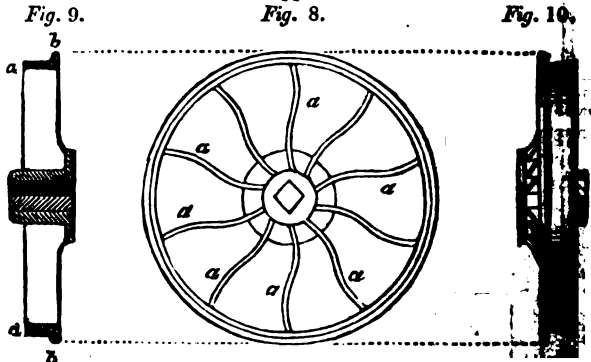
*Fig. 4* represents an elevation of the edge railway, showing a rail *a* connected with the two adjoining rails, the ends of which are shown by *b b*, and resting in the props or pedestals, the bases of which are the metal chairs that are bolted to the stone supports *c c*. The joints *e e* are made by the ends of the rails being applied to each other by what is termed a half lap; and the pin or bolt *g* which fixes them to each other, and to the chair in which they are inserted, is made to fit exactly a hole which is drilled through the chair and both ends of the rails, at such a height as to allow both ends of the rails to bear on the chair, and the bearance being the apex of a curve, they both bear at the same point. Thus the end of one rail cannot rise above that of the adjoining one; for although the chair may move on the pin in the direction of the line of the road, yet the rails will still rest upon the curved surface of their bearance without moving.

*Fig. 5* is a cross section of our edge-railway through the middle of one of the chairs *a*, and across the ends of the two adjoining rails, which are connected by a transverse pin; *c* is the stone support or sleeper.

*Fig. 6* is a cross section of the rail *a*, at the centre, and shows the supports at the farther extremity.

*Fig. 7* is a plan of the railway described at *Fig. 1*, showing the half-lap joints of the rails *e e* placed in their carriages *d d*.

*Fig. 8*, in the subjoined cut, is a view of the cast-iron wheel with the malleable iron tire. This wheel is made with curved spokes, as shown at *a a a*, and with a slit or aperture in the rim, shown at *b*, into which a key is inserted. The reason of this is, that on the application of the hot tire, the cast metal



expands unequally, and the rim is liable to be cracked, and the rims drawn off, unless the first is previously slit or opened, and the latter curved, which allow them to accommodate themselves to the increased diameter of the wheel; by this formation of the wheel, the tire may be placed on when cold, and keyed up afterwards.

Fig. 9 is a cross section of Fig. 8, through the centre. *a a* show the tire; *b b* the metal rim. This cast metal rim is dovetailed; so that when the tire, which is dovetailed to suit it, is put on hot, it contracts, and applies itself to the rim with a degree of adhesion which prevents its coming off from the motion of the wheel on the railway. This wheel is of the form to suit an edge-railway; and to make it answer for a plate-rail, it only requires the rim to be flat.

Fig. 10 is an end view of Fig. 8 without the malleable iron tire.

The same patent comprises improvements in "rolleys" or tram-wheels, and in tram-plates. The first consists in the combination of cast and wrought-iron, after the same method as already described with respect to the larger or edge-rail wheels; and the second consists in some judicious modes of fixing the tram-plates to the chairs, through the means of tenons and mortices, so that the ends of the rails are kept firmly in their places.

The transit of coals from the mines to the place of shipment added so much to their cost, that the owners were naturally solicitous to adopt any improvement calculated to lessen it. And the great ameliorations introduced by Messrs. Losh and Stephenson, just described, were of so decided a character, as to become very generally preferred in the collieries of the north; where they continued in use for many years. There was, however, an unquestionable defect in the material used. Cast-iron, although it offers great facilities in producing the desired shapes to resist strains; to economise metal in those parts where much strength is not required; and to afford the most convenient adaptations in fitting together, can never be entirely depended upon, until certain and *easily practised* means shall be discovered of expelling the air contained in the moulds. From the casting's being often *blown* in invisible places, frequent breakages were unavoidable, from this cause alone; to which may be added, the derangements of the substructure of the line, which, however well executed, is always taking place in different parts, according as they may be subjected to the various disturbing causes; such as wet, friction, concussions, &c., altogether producing, in extensive lines, a very serious amount of breakage, and a heavy expense for repairs; nevertheless, previous to Messrs. Losh and Stephenson, the expense of repairs was much greater.

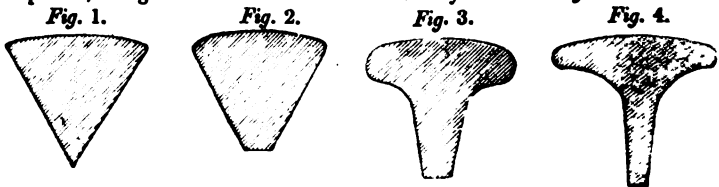
Although the rails in general use were for the most part of cast iron, there were some of malleable iron, made of the ordinary rectangular figure by rolling; which latter were liable to be rendered unserviceable by becoming bent. To remedy this defect in the malleable, and the liability to break in the cast iron, Mr. John Hawks, of Gateshead, Durham, took out a patent in the year 1817, "for a new method of making rails," in which the metal in both its states was combined. The specification states, "Instead of making the rails or bars of cast or malleable iron, as those now in use are, they are a compound of malleable and cast iron, so connected as to be stronger than if made of either kind alone. The surface is formed of cast iron, and the back, or under part, of malleable iron, joined together and formed when the metal of the former is in a fluid state; and they become so inseparable that the cast iron may be broken at the nearest possible distances; indeed, even inch by inch, which is scarcely possible to be occasioned by accident, and the rail will remain sufficient for the purposes of a railway; at least, till it suits the convenience of the workmen to replace it, without interruption to the concern in which the railway may be used: and as a loss by a broken rail of this invention will be less than one in common use, the expense, although it may be a little more in the first instance, will be considerably less in the end, as the malleable iron may be used again, or as the old iron will be of much more intrinsic value than the other."

The modes of combining cast and malleable iron together in the rails are various; but that which Mr. Hawks preferred as affording the best security for their being firmly fixed together, is by running the cast iron, when in a state of fusion, on the malleable iron; to effect which the malleable part is to be first forged, or otherwise prepared in that form and of that strength which the nature of its intended purpose or appropriation points out as most proper. That part of the malleable iron which is intended to be combined with the cast iron

should be rendered rough and uneven by jaggings or by perforation, by giving it a dovetailed form, or by any other means, so that the cast iron may firmly adhere thereto, without the liability of becoming loose by the violent action of the carriages. The malleable part must be clean, perfectly dry and warm, when laid in the mould to receive the melted iron, which should be poured in as soon as possible after the mould is ready to receive it, as any damp on the malleable iron will endanger the soundness of the cast iron part.

It is a remarkable fact in the history of our iron manufacture, that at so advanced a period as 1817 no attempt had been made to make railway bars of malleable iron of a judicious form, like those used in the cast metal. It would seem that the manufacturers of that time imagined that their grandfathers had taught them all that it was possible to acquire in their art of rolling bars; that it was too wild an attempt to make any other form than cylindrical and rectangular, although they might obviously effect the required configuration by the same tools and machinery, with merely a slight deviation in the form of the grooves. In consequence the proprietors of the railways and coal-works went on breaking their cast iron and bending their weakly shaped malleable bars, incurring for three years afterwards very serious accidents and loss. At length Mr. John Birkenshaw, of Bedlington, made the notable discovery we have just alluded to, (and which we should have thought would have been obvious to everybody,) of making the grooves of the shape desired. He took out a patent for his invention in 1820, and made, it is said, a considerable fortune by it; his specification we will now make an extract from:—

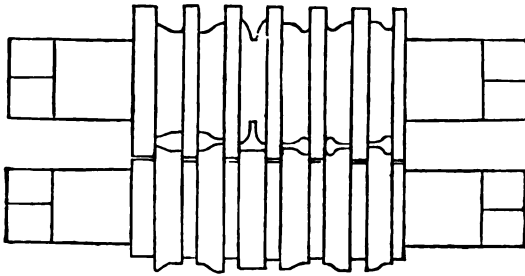
“My invention consists in the adaptation of wrought or malleable iron bars or rails of a peculiar form, instead of cast iron rails, as heretofore. From the brittle nature of cast iron, it has been found, by experience, necessary to make the bars of a railroad sufficiently strong to bear at least six times the weight intended to be carried along the road, by which the original cost of a railroad was considerably augmented; or if light rails were used, the necessity of frequently repairing entailed a very heavy expense upon the proprietors. To obviate these objections, I have invented a bar to be made of wrought, or malleable iron, the original cost of which will be less than the ordinary cast iron rails or bars, and, at the same time, will be found to require little (if any) reparation in the course of many years. The rails or bars which I have invented are formed as prisms, though their sides need not of necessity be flat. *Figs. 1 and 2 show*



sections of the bar thus formed; the upper surface upon which the wheel of the carriage is to run is slightly convex, in order to reduce the friction; and the under part rests in the supporting-blocks, chairs, rests, standards, or pedestals, which are mounted upon the sleepers. The wedge-form is proposed, because the strength of the rail is always in proportion to the square of its breadth and depth. Hence this form possesses all the strength of a cube equal to its square, with only half the quantity of metal, and, consequently, half the cost. Sufficient strength, however, may be still retained, and the weight of metal further reduced, by forming the bars with concave sides, as shown in section, by *Figs. 3 and 4.*”

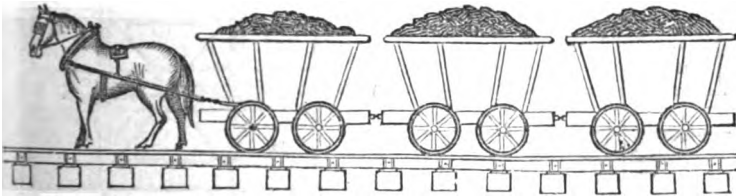
The rolls made use of by Mr. Birkenshaw are exhibited in the annexed figure, which represents an elevation or side view of a pair of them. It will be observed that the circumference of each roll is indented by a series of grooves; each groove in the upper roll corresponding in shape with those of the lower roll, excepting in one case. Consequently the figures described by the hollow spaces between each roll, represent the form of the bars to be made.

It will therefore be obvious, that when a red-hot bar of iron is applied to the grooves of such rollers, forced round by a powerful steam-engine with great velocity, the iron will be compressed into the same form throughout its length.



The form of rail now most approved of, which we shall have occasion hereafter to describe, is made by the same kind of machinery.

The annexed wood engraving is designed to show Mr. Birkenshaw's railway, the kind of waggons used, and the nature of the power at that time in general



use. The superiority of Mr. Birkenshaw's rail over that in general used previously, which was the joint invention of Messrs. Stephenson and Losh, excited the rivalry of the latter gentleman; accordingly we find him taking out another patent for "certain improvements in the construction of iron rails for railroads," which being to us very doubtful, we shall describe it very briefly in his own words:—"First, in using, placing, and fixing bars of malleable iron on the upper surface of a line of cast iron rails or malleable iron rails, of whatever form such rails may be in the longitudinal direction of the rails when laid, so as to form an uninterrupted line the whole length of the bar, which may be as long as it shall be found convenient and economical to use, and of the same breadth as the upper surface of the rails to which it is fixed, or a little broader or narrower. Secondly, in some cases I fix a band or strap of malleable iron to the under surface of rails made of cast iron, in order that such band or strap may, by its power of tension, give support to the cohesion of the parts of the cast iron rails, and admit of its being made lighter, and thus save expense, while it adds to security from breakage. Thirdly, I claim as an improvement, a rail formed by fixing two bars of malleable iron on their sides or edges, and fixing them in that position by bolts and studs, or by any other convenient method; and on their upper edges placing and fixing a flat bar of malleable iron, or one which is slightly curved or rounded at the edges to diminish friction, so that the bar or plate, placed and fixed on the upper edges of the two malleable iron bars, shall form the surface upon which the wheels of the waggon or carriage are to revolve." After this statement, we think the practical reader will not be disappointed if we omit the details of construction.

A new species of railway, possessing many advantages peculiar to itself, was invented and patented in the year 1821 by the late Mr. H. R. Palmer, who was for some years engineer to the London Dock Company. Instead of two lines of rail laid upon the ground, as heretofore, Mr. Palmer's railway consists of only one, which is elevated upon pillars, and carried in a straight line across the country, however undulating and rugged, over hills, valleys, brooks, and



riders, the pillars being longer or shorter, to suit the height of the rail above the surface of the ground, so as to preserve the line of the rail *always straight*, whether the plane be horizontal or inclined. The waggons, or receptacles for the goods, travel in pairs, one of a pair being suspended on one side of the rail,

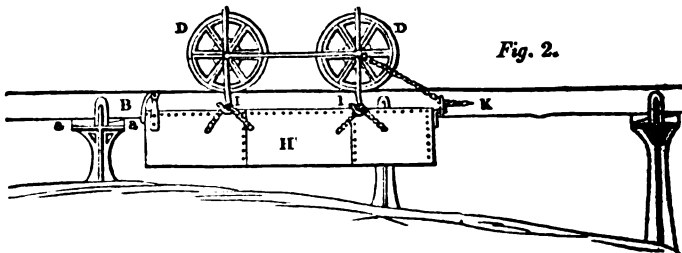


Fig. 2.

Fig. 1.

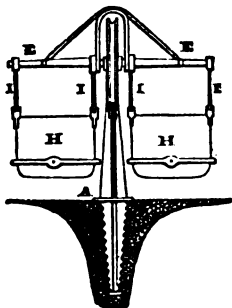
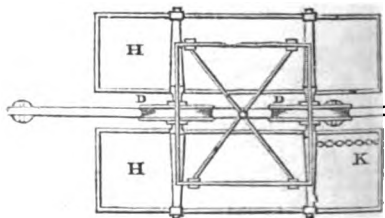


Fig. 3.



and the other on the opposite side, like panniers from the back of a horse. By this arrangement only two wheels are employed, instead of eight, to convey a pair of waggons; these two wheels are placed one before the other on the rail, and the axle-trees upon which they revolve are made of sufficient length and strength to form extended arms of support, to which are suspended the waggons or receptacles on each side of the rail, *the centre of gravity being always below the surface of the rail*. The rods by which the waggons are suspended are inflexible; hence, although the weights on each side be not equal, they will, nevertheless, be in equilibrium; as may be observed in a ship, which, being unequally loaded, assumes such an angle with the surface as preserves the equilibrium. Although an equal distribution of the load on both sides is desirable, it is not necessary. A number of carriages are linked together, and towed along the rail by a horse, as barges on a canal. Owing to the undulation of the country, the horse will sometimes be much below the rail, in consequence of which he is provided with a sufficient length of rope to preserve a proper angle of draught.

Fig. 1 is an end view of the carriage, with a cross section of the rail, and a pillar, showing its form, and manner of fixing.

Fig. 2 is a side view of the railway passing over an uneven surface, with three of the supporting pillars of unequal length. Upon the upper surface of the rail are seen the two carriage-wheels, and the manner of suspending the waggons or receptacles from the axle-trees, which is, however, better shown by Fig. 1, letters I I I.

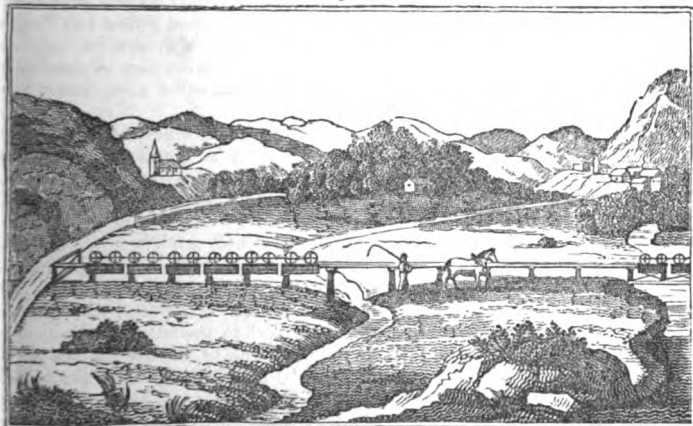
Fig. 3 is a plan of the same, which exhibits the comparative measurements, and the mode by which the receptacles are braced together. The same letters of reference refer to the same parts in the different figures. A, Fig. 1, represents an upright pillar of cast iron, having, at the shoulder, a flange, which rests upon the surface of the ground. The pillar is formed with ribs at right angles,

which converge towards the lower extremity, and are notched in the edges, for the better securing it firmly in the ground. The hole in which it is to be inserted is to be previously well rammed, by a kind of pile-driving engine, and the foot of the pillar surrounded with hard materials, which are also to be rendered as compact as possible. Three of these pillars are shown fixed in *Fig. 2*, placed about nine feet apart. At the upper extremities of the pillars are long clefts or openings, to receive the rail B, which is composed of deal planks, set on their edges, with their upper surface D defended by cast or wrought iron plates, a little convex on the upper side. When the rail has been some time in use, and all has taken a bearing, a little adjustment of the line may be requisite before the rail is bolted to the pillars; to effect which, a very simple and easy method is provided. In the cleft of the pillars, and under the rail, two wedges *a a* are introduced in opposite directions, whereby its level may be adjusted with the nicest accuracy. The wheels D D are provided with flanges, to keep them on the rail, and their peripheries are slightly concave, to adapt their surfaces to that of the rails. E E are the arms or axles; H H are the receptacles for the goods, which are made of plate iron, and are suspended to the arms, as before mentioned, by the inflexible rods I I I I. To one of the arms a chain K is hooked, to which a towing-ropes may be connected. Any number of carriages may then be attached together by chains hooked on to the angles.

The annexed *Fig. 4* is intended to exhibit a portion of the railway in use, and the methods by which several of the obstacles which frequently present themselves are overcome. On the left is seen a jointed rail, or gate, that crosses the road over which the carriages have just passed, and the gate swung back, to leave the road open; the horse and man having just forded, the train of carriages is proceeding in its course, and following another train, part of which is seen on the right, crossing a rail bridge, simply constructed for that purpose.

Provision is made for trains of carriages that are proceeding in opposite directions, by means of "sidings" or passing places. With respect to loading, if both receptacles be not loaded at the same time, that which is loaded first must be supported until the second is full. Where there is a permanent loading-place, the carriage is brought over a step or block; but when it is loaded promiscuously, it is provided with a support connected to it, which is turned up

*Fig. 4.*



when not in use. From the small height of the carriage, the loading of those articles usually done by hand becomes less laborious. The unloading may be done in various ways, according to the substance to be discharged, the receptacles being made to open either at the bottom, the ends, or the sides. In some cases it may be desirable to suspend them by their ends, when, turning on their own centres, they are easily discharged sideways.

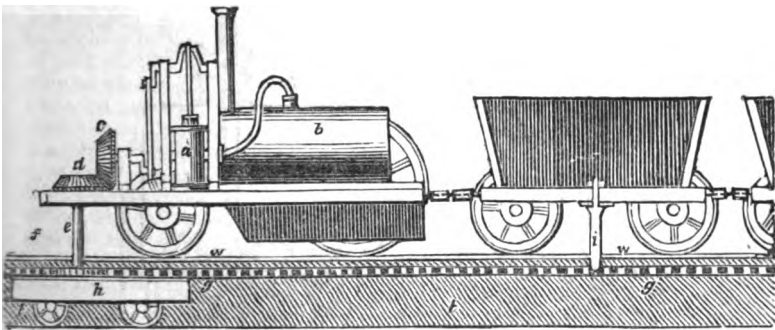
Among the advantages contemplated by the patentee of this railway, may be mentioned that of enabling the engineer, in most cases, to construct a railway on that plane which is most effectual, and where the shape of the country would occasion too great an expenditure on former plans—that of being maintained in a perfectly straight line, and in the facility with which it may always be adjusted; in being unencumbered with extraneous substances lying upon it; in receiving no interruption from snow, as the little that may lodge on the rail is cleared off by merely fixing a brush before the first carriage in the train; in the facility with which the loads may be transferred from the railway on to the carriages, by merely unhooking the receptacles, without displacing the goods, or from other carriages to the railway, by the reverse operation; in the preservation of the articles conveyed from being fractured, owing to the more uniform gliding motion of the carriages; in occupying less land than any other railway; in requiring no levelling or road-making; in adapting itself to all situations, as it may be constructed on the side of any public road, on the waste and irregular margins, on the beach or shingles of the sea-shore,—indeed, where no other road can be made; in the original cost being much less, and the impediments and great expense occasioned by repairs in the ordinary mode, being in this method almost avoided.

A line of railway on this principle was erected, in 1825, at Cheshunt, in Hertfordshire, chiefly for conveying bricks from that town, across the marshes, for shipment in the river Lea. The posts which support the rails are about ten feet apart, and vary in their height from two to five feet, according to the undulations of the surface, and so as to preserve a continuous horizontal line to the rail. The posts were made of sound pieces of old oak, ship timber, and in the slots or clefts at the upper ends of the posts, are fixed deal planks twelve inches by three, set in edgeways, and covering with a thin bar of iron, about four inches wide, flat on its under side, and very slightly rounded on its upper side; the true plane of the rail being regulated or preserved by the action of counter-wedges between the bottom of the mortices, and that of the planks. By this rail, on the level, one horse seemed to be capable of drawing at the usual pace about fourteen tons, including the carriages.

The next invention in the order of time that presents itself to our notice, is one possessing considerable originality; and though it has not been carried into effect, it contains some ingenious suggestions, that have formed the groundwork of subsequent inventions. It is the subject of a patent granted to William Francis Snowden, of Oxford-street, London, on the 18th of December, 1824, for a "new invented wheel-way and its carriages for the conveyance of passengers, merchandise, and other things, along roads, rails, and other ways, either on a level or inclined plane."

The specification describes the invention under two distinct heads; the first, which is the most practical of the two, is explained as consisting of a hollow trunk with a platform of iron on the top for waggons or other carriages to roll upon; inside the trunk is placed a machine, called by the patentee a mechanical horse, to which is connected a toothed wheel, that is made to revolve in a horizontal plane, and to take into the teeth of a horizontal straight rack fixed on one side of the hollow trunk. The vertical axis of the horizontal toothed wheel passes through a longitudinal opening in the wheel-way; above which it is connected to a locomotive steam-engine, and is actuated thereby; through the medium of bevil gear the motion thus communicated to the latter by the engine is applied by the vertical axis to the horizontal wheel of the mechanical horse, inside the hollow trunk; and as the horizontal wheel is geared into the toothed rack, which is *fixed* on one side of the trunk, the mechanical horse of necessity moves forward with the same velocity as the horizontal wheel is made to revolve by the power of the engine. This will be understood upon reference to the annexed figure, which affords a longitudinal section of the mechanical horse, and the hollow trunk or wheel-way. *a* is a vibrating cylinder, and *b* the boiler of a locomotive engine, by which the bevil gear *c d* is actuated, and through the medium of the vertical axis *e*, the horizontal toothed wheel *f* which takes into a toothed rack *g*; the mechanical horse *h* is made to advance in its course,

and to take with it the engine and the train of waggons that may be in connexion. *ww* is the wheel-way, and *tt* the hollow trunk. As the top of the wheel-way is supposed to be flat, and the carriages without lateral flanges to their tires, it is proposed to guide the carriages by means of tongues like that at



*i*, which enters the longitudinal aperture, and which may be provided with an antifriction roller to prevent lateral rubbing. The inventor proposes to adopt a similar arrangement to the foregoing for the towing of barges, by erecting his patent wheel-ways by the sides or banks of canals and rivers.

In the preceding pages are given some plans for the employment of toothed racks to railways, to enable a carriage, provided with a toothed wheel, taking into the teeth of the rack, to obtain sufficient resistance to ascend steep inclined planes: but the former were subject to the disadvantage of a strain or twist, the rack in them being placed on one *side* of the way. To obviate this defect appears to have been the object of Mr. Josiah Easton, who took out a patent, dated the 13th October, 1825, for "certain improvements in locomotive or steam carriages, and also in the manner of constructing the roads or ways for the same to travel on." The following brief description of this invention is given in the *London Journal of Arts*, Vol. XI. :—"These improvements consist, first, in forming a line of road, with a raised part along the middle, upon which a rack, or toothed bar of iron is placed; and secondly, in adapting a toothed wheel to the steam carriage, which shall take into the said rack, and being actuated by the rotatory power of the steam-engine, shall thereby cause the carriage to be impelled forward upon the line of railroad, and the trams or other waggons after it."

In the subjoined cuts, *Fig. 1* exhibits a transverse section of the railroad, with the end view of a wagon upon it. *Fig. 2* is a side elevation of the same, showing the manner in which the carriage is driven; *aa* is the road formed of masonry, the parts *bb*, on which the running wheels travel, being on a lower plane than the central part *c* of the road, whereon the rack *d* is situated. The steam-engine, and other machinery appertaining to the locomotive, are constructed in the usual way; the only novelty in the carriage is the toothed wheel *e*, which takes into the rack *d*, fixed along the centre of the road; and this toothed wheel being made to turn through the agency of a train of wheels actuated by the steam-engine, the carriage is thereby propelled, and the waggons drawn after it. In order to keep the carriages in their track upon the road, two guide rollers *ff* are placed under the carriage, which run against the side of the central rib, and this prevents them from moving out of their course.

*Fig. 1.*

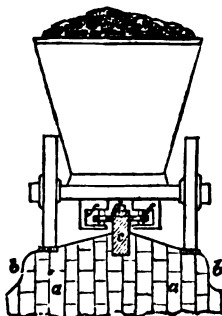
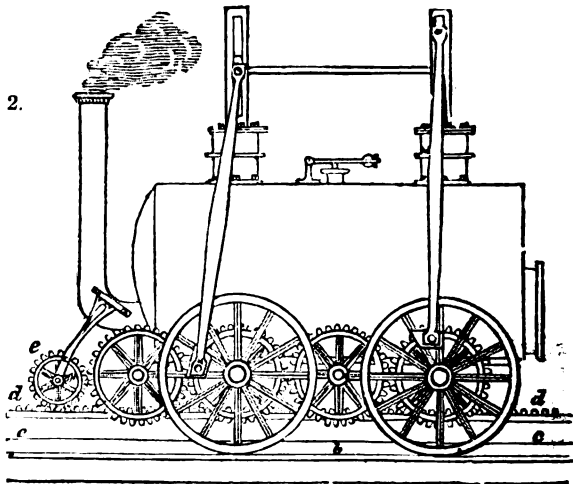


Fig. 2.



To enable locomotive carriages to ascend steeper inclined planes than had heretofore been considered practicable, and likewise to enable the carriages and trains to wind round curves in the road, without the severe friction and straining to which they had been previously subjected, was the object of a patent granted on the 5th of March, 1825, to Mr. W. Henry James, of Birmingham. This invention has not, we believe, been carried into effect on the great scale; but we have been credibly informed, that the most satisfactory proofs have been afforded of the ability to effect this, by repeated trials on a railroad more than a hundred feet in length, laid down for the purpose of experiment, on which it was found that a train of carriages would ascend inclined planes three inches in the yard, which is equal to 440 feet in the mile. This important advantage is gained by applying the power to the axletrees of the wheels of the several carriages in the train, by means of the rotation of a long horizontal rod (or series of connected rods), actuated by bevel gear under each carriage.

An ingenious plan has also been proposed by Mr. James for enabling the carriages on a railway to pass around turns or curves in the road, without additional friction. For this purpose, the horizontal rotatory shafts, which cause each pair of wheels in the train to revolve, and propel the carriages forward, are connected together by a novel kind of universal joint, which communicates the rotatory motion to each successive carriage, even if so placed on the curves of the roads, that the sides of one carriage shall present to the side of the next an angle of thirty degrees. To cause the carriage wheels to run round the curves of the railway, without the usual destructive rubbing of their surfaces, the rails in those parts are made with several ribs or elevations, and the wheels of the carriages are consequently formed to correspond with those ribs, by their peripheries being grooved in like manner; so that a wheel, in effect, possesses as many diameters as there are variations in the surface of its periphery, by which means it may be made to travel faster or slower, as may be desired.

The following engravings will render these plans intelligible to the reader. *a* is the boiler of a steam-engine; *b* the engine with two cylinders, the alternating motion of the piston in which gives rotation to the crank *c* above: the rods *e e*, attached to the same, being also fixed to the crank of the horizontal shaft *fff* (which passes under the carriages), causes that to revolve with a similar speed to the crank of the engine. Two square boxes, *g g*, are fixed under each carriage; through these the axletrees of each pair of wheels pass; the rotatory shaft *f* passes also through the boxes above the axletrees, and at right angles with them; each of the boxes *g g* contains a double-beveled horizontal wheel,

which presents a circle of cogs in its upper as well as its lower side, and turns upon cross bearings: now the shaft *f* carrying upon it a vertical beveled pinion in each box, takes into the upper circle of teeth of the horizontal wheel, while the under circle of the teeth of the same actuate a beveled pinion on the axle-tree underneath, consequently compelling the wheels to revolve; and the power being thus applied to every pair of wheels simultaneously, sufficient resistance is obtained, on a smooth surface, to ascend inclined planes of considerable elevation. *u u u* are the universal joints, which communicate rotatory motion

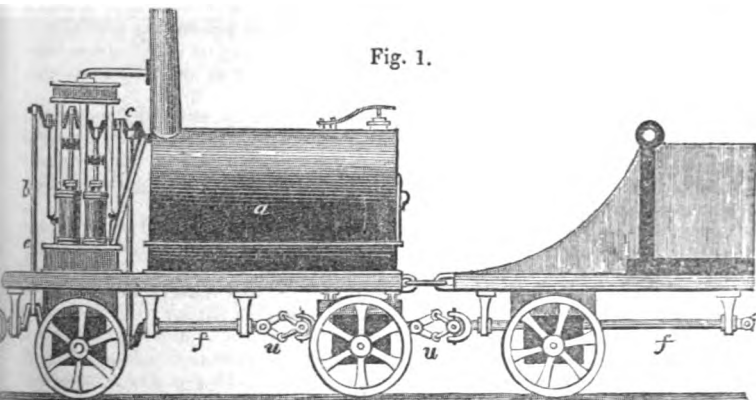


Fig. 1.

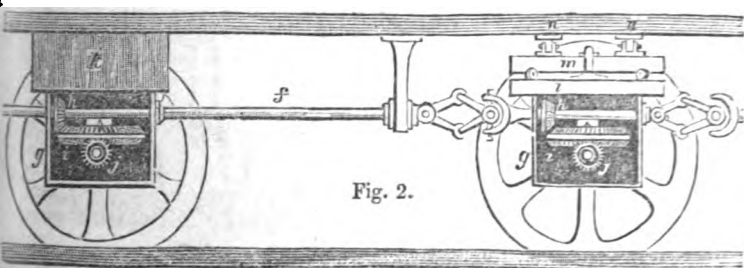


Fig. 2.

when the carriages are not in a straight line; these, and other moving parts, are distinctly shown in *Fig. 2*, which is upon a larger scale. *ff* is the rotatory shaft; *gg* the two boxes, with the front plates moved, to show the gear inside; *k k* the beveled pinions upon the shaft in each box; *ii* the horizontal double-beveled wheels. The front box *g*, under the carriage, is fixed immovably to a solid block of wood, *k*; the other box is fitted to a plate *l*, turning on a central point, which passes through another plate *m*, above, the latter being secured to the floor of the carriage by hinge-joints, *u u*. The construction of the universal joints *u u* is also more clearly shown in this figure.

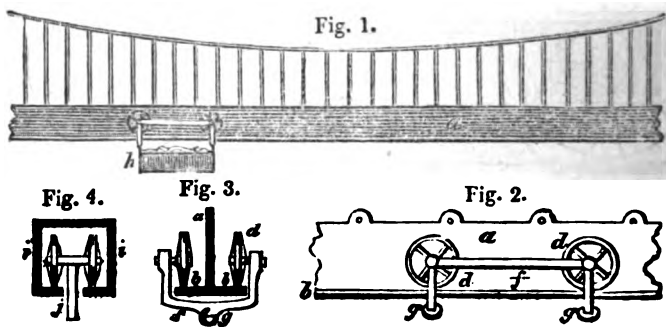
We have now to describe the contrivances by which the patentee proposes to obviate the destructive effects of the rubbing or sliding of the inner wheels of carriages in making curves or turns in a round. If the wheels on one side of a carriage be larger, or of greater diameter than those on the opposite side, such carriage, when propelled, will necessarily make a curve. On this principle the patentee's contrivances are founded. In running along a straight line, the peripheries of the wheels are of equal elevation; but when the carriage has to make a turn, the wheels on one side roll on a greater diameter, or more extended periphery, while the wheels on the opposite side run on a less extended periphery, and the elevations upon the rails on which they run are so adjusted to these variations, that the different peripheries of the wheels change and come

in contact with the variable parts of the rail, and run round the curves without any increase of friction.

A patent for a suspension railway was granted to Mr. J. G. Fisher, on the 2d of April, 1825. This gentleman, it will be observed, suspends his carriages to a double line of rail; in this respect, however, he was anticipated in *idea* by Mr. Palmer, who, in his little interesting book, entitled, *Description of a Railway upon a New Principle*, observes,—“to elevate two lines of rail for the purpose of supporting a carriage, could not be done at a sufficiently moderate expense; I therefore endeavoured to arrange the form of a carriage in such a manner that it would travel upon a single line of rail without the possibility of overturning.” Nevertheless, if an inventor can succeed in carrying into beneficial operation that which was thought of by another as ineligious to attempt, he is entitled to respectful consideration.

Mr. Fisher's plan is, however, not without originality, and, with some modifications, may be rendered useful in many situations. The chief object is stated to be the throwing of a railroad across rivers, swamps, &c.; and the means proposed of effecting it will be readily perceived upon inspecting the following diagrams, and referring to the subjoined explanation of them.

Fig. 1 is a side view of the proposed rail, attached by vertical rods to a chain of bars, which form a catenarian curve; Fig. 2 is a similar view, but giving only a portion of Fig. 1 on a larger scale; Fig. 3 is an end or sectional view of Fig. 2; Fig. 4 is also a sectional view, but of another form of rail, which we shall describe lastly. The letters of reference denote similar parts in each of the figures. *a* is the rail, made of stout cast-iron plates, of uniform dimensions, bolted together, having a horizontal projection, or plate, *b b*, on each side, for the wheels of the carriages, *d d*, to run upon (seen best in Fig. 3); *f f* shows the frame of the carriage: the manner of constructing the wheels on either side of the rail, in pairs, is exhibited in Fig. 3, and the mode of joining the front with the hind pair of wheels, in Fig. 2. Iron rings, *g g*, pass through the centres of the lower parts of the carriage-frame, to which are suspended the boxes or



receptacles for holding the goods or passengers, one of which is shown attached at *h*, Fig. 1. The loops or holes in the upper part of the rail *a*, Fig. 2, are, of course, for the convenience of bolting it to the suspension bars, as seen connected in Fig. 1. Each of the bars is to be provided with a wedge or screw adjustment, so as to regulate the uniformity of the plane when any part sinks. To give an idea of the other form of rail, the section Fig. 4 is sufficient. Here it will be seen that the rail (if we may so term it) is of the form of a square tube or hollow trunk, *i i*, with an opening or slit on the lower side for the bar *f* (which is fixed to the axletree of the carriage) to pass through, for the purpose of being connected to a box or receptacle underneath. This square cast-iron trunk, or rail, is to be suspended, as in the previously described rail, to a chain of iron bars or wires, drawn nearly tight, so as to form a catenarian curve when stretched over the place to be crossed.

The mode of propelling the carriages is, we believe, not stated in the specification, but we understand it is to be performed, when the crossing of rivers or ravines is the object, by elevating that end in which the carriages are placed, and letting them find their way to the other end by their own gravity. By such a proposition, it is probable that the patentee does not intend it for any extensive work, as the means proposed of producing motion are applicable only to such cases as we have mentioned.

As it is indispensable that carriages which have to run upon edge railways should be provided with wheels that have lateral flanges upon their peripheries to prevent them from running off it; and as such projecting flanges render them inapplicable to carriages on the common road, into which they would make deep destructive incisions, if drawn or propelled over them, it necessarily became of importance to contrive such a wheel, or periphery of a wheel, as would run without detriment on either road or rail. We think we have noticed several methods of providing for this object: but that which appertains to our present chronological position is the subject of a patent granted to R. W. Brandling, Esq., of Newcastle-upon-Tyne, on the 12th of April, 1825. The wheels he uses for this purpose have tires, provided, as it were, with two peripheries or external circles of different diameters. Thus, upon an edge rail, the periphery of the smaller diameter of the tire runs upon it, and the larger diameter becomes the guiding flange to keep the carriage in its course. And when the same are run upon a common road, the larger diameter only comes into operation, keeping the smaller diameter clear of the ground, unless the latter should be in a soft state, when it will tend to keep the wheel from sinking deeper in the road. This patentee has likewise included in his specification some plans for making turns or curves in the roads, by means of projecting ribs on the surface of the rail of different elevations, with wheels designed to correspond thereto; but as in these contrivances Mr. Brandling was anticipated a few weeks prior by Mr. W. H. James (already described), we shall not here enlarge on the subject.

In the invention patented by Mr. Thomas Hill, Jun., of Ashton-under-Line, dated the 10th of May, 1825, that gentleman proposes to construct a steam-carriage equally adapted to run upon edge-rails, tram-plates, and the common road. For this purpose he makes the guiding flanges removable at pleasure by the withdrawal of bolts, by which they are connected to the felloes of the wheels. Another invention consists in making the running wheels of the carriage revolve loosely upon a fixed axletree, which, when applied to railways, he considers to be a new and useful invention. This is, however, a mistake, as they have been so used, but were abandoned on account of their unsteadiness, and other defective action. A third contrivance is to lock the fore-axle to the perch, to prevent its turning round when upon a Railway, by means of a square staple entering loops or eyes. A fourth invention consists in making the rails of tubes instead of solid bars, to save metal, and obtain strength. There are some other trifling appendages or alterations to steam-carriages and railroads, for the description of which we must refer the reader, who may require more information, to the enrolled document.

A suspension railway, combining the characteristic features of Mr. Palmer's and Mr. Fisher's previously described, was patented by Mr. Maxwell Dick, of Irving, in Ayrshire, on the 21st of May, 1829; doubtless, in ignorance of those precedents, as we were personally assured by the latter patentee. The chief object of this gentleman was, as is stated in the title of his patent, "for the conveyance of passengers, letters, intelligence, packages, and other goods, with *great velocity*." The means which he adopts for this purpose, are designed to obviate the necessity and enormous expense of cutting and embanking resorted to on railways of the ordinary kind. The rail is supported, like Mr. Palmer's, upon vertical pillars, but carrying a double track for the carriages, like Mr. Fisher's. Mr. Dick has, however, added, what he denominates "safety rails," one on each side of the track, against which anti-friction wheels, attached to the carriages, are made to act, in case of the carriages receiving from any cause an impulse upwards. The patent likewise embraces a combination of



wheel-work, for communicating a high velocity to the carriages. A large and well constructed working model of this invention was publicly exhibited for several weeks at Charing Cross, London, in 1830, and drew crowds of visitors, who were surprised and delighted at the velocity with which the carriages darted along the wire rails across the room, by the application of a small force. The notoriety of this invention, as well as the capability of its being usefully applied under many circumstances and situations, for light loads at high velocities, seems to require from us something more than this brief historical notice. Accordingly we proceed to give a few, out of the many details and modifications, which the prolific mind of the inventor has thrown together in his specification. From this document we learn that the patentee especially designed his invention for traversing undulating, rugged, and abrupt ground, the crossing of rivers, mosses, marshes, &c. Pillars are to be erected of brick or stone with lime, at given distances apart, suppose fifty yards; between each of these may be placed four or five cast metal pillars, according to circumstances, for bestowing the requisite stability and keeping the rail free from undulations. On the top of each of the pillars is to be fastened a frame, to which the rails are to be secured, and to the frames are connected grooved friction wheels or pulleys, between which the drag-line is conducted. The rails are to be made of the best wrought iron, such as is used for chain cables, and they are to be duly connected together in great lengths, and secured to the frames in such manner as to make the top surface smooth, and free from all obstruction to the motion of the carriages. Between each frame there are to be introduced three or four cast-iron braces, to prevent vibration and stiffen the structure. The method proposed for dragging the carriage along the railway, is by fixed or stationary engines acting with drag-lines or ropes attached to the carriage, which, if the railway be double, (as in the subjoined illustration) will act in an endless round; but if the line of railway be single, then the engine will be interchangeable and reciprocal.

Fig. 1.

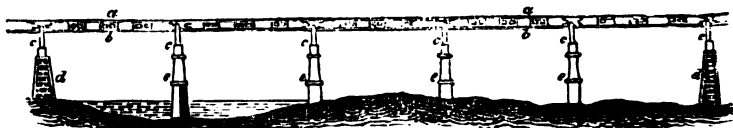


Fig. 1 represents a side elevation of one span of a double suspension railway, supported at the extremities by a pier of masonry, *d d*, and at equal distances by four cast-metal pillars *e e e e*. *a* is the upper or "bearing rail;" *b* the lower or "safety rail," which are bound together by intermediate stay braces, better shown on a larger scale at *f f* in figures 2, 3, and 4.

Fig. 2.

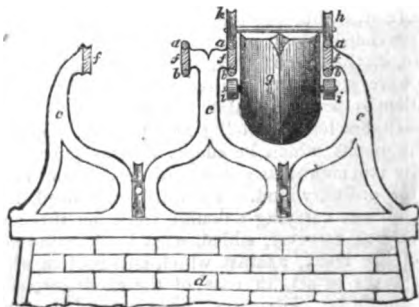


Fig. 2 shows a front elevation of a frame *c c c*, for a double line of rail, with a carriage on one of them at *g*. The letters of reference in this figure, as in all the others, designate similar parts; it therefore need only be said, that the stay braces *f f* are seen in section between the rails *a b*.

Fig. 3 gives a side elevation of a carriage on a portion of rail; *h h h* being the running wheels, and *i i i* the anti-friction rollers, which prevent the carriage from being thrown off the railway. An examination of Fig. 2, which exhibits the end view of this carriage, will fully explain its form and construction.

Fig. 3.

Fig. 4.

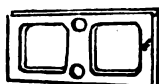
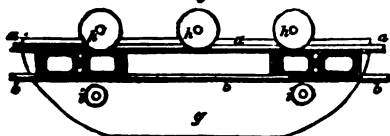


Fig. 4 is a perspective sketch of one of the stay braces on a larger scale. The expense of one mile of railway on this principle is calculated at 1395*l.* 10*s.* 6*d.* The advantages contemplated are stated by Mr. Dick as follows: "In the first place, as you save distance, so do you save time; which all must admit, that in a commercial as well as in a political point of view, is of the utmost importance. The suspension rail takes a straightforward point from one town to another, without regard to the surface of country over which it has to go, whether rising or falling, crossing of rivers, or otherwise. All are, by regulating the heights of the pillars, with the same ease gone over, and by that means saving of distance, saving of surface ground, saving bends in the formation of the rail; which bends, besides the extra expense of originally laying, are always liable to great derangement from the lateral friction of the waggons coming round them, compared to that of a straight line of rail. Secondly, the suspension railway, over that of the ground railway, has another immense advantage; that is, as far as expense is concerned, which is, in the saving of all embankments, excavations, building of bridges, cutting of tunnels, besides the great breadth of surface ground. Thirdly, and which I think the most important of all, is the great despatch to be gained by the suspension railway, without, in the least degree, endangering either persons or property, its height being sufficient at all places to allow every agricultural and commercial intercourse to go under it without interruption: and then the carriages being so completely locked within the rail prevents any chance of their escape, whatever may be their velocity."

We conclude our account of the second era, by a notice of the construction of the Manchester and Liverpool Railway.

Liverpool is the port whence Manchester receives all her raw materials, and to which she returns a large portion of manufactured goods for shipment to all parts of the world. By means of the railroad, the transit of goods is now effected in about one eighteenth part of the time previously occupied by the water conveyance of fifty miles, besides a saving of fifty per cent. in the cost per ton of carriage; and these two great towns are by thirty-one miles of railway, as much connected for the purposes of business or pleasure, as the eastern and western extremities of London. The undertaking was commenced in June, 1826, under the direction of Mr. George Stevenson. It runs in nearly a straight line. The following are the gradients of the line:—

	Miles. Yds.	Planes.
Tunnel under the Town of Liverpool, from } Wapping to Edge-hill . . . . . }	1 240	Rise, 1 in 48.
Level . . . . .	0 1000	Level.
To the Foot of Whiston, or Rainhill Plane . .	5 220	Fall, 1 in 1092.
Rainhill inclination . . . . .	1 880	Rise, 1 in 96.
Rainhill level . . . . .	1 1540	Level.
Carried forward . . . . .	10 360	

	Miles.	Yds.	Planes.
Brought forward . . . . .	10	360	
Sutton plane . . . . .	1	880	Fall, 1 in 96.
Parr Moss . . . . .	2	880	Fall, 1 in 2640.
Ditto . . . . .	6	880	Fall, 1 in 880.
Chat Moss . . . . .	5	880	Rise, 1 in 1200.
To Manchester . . . . .	4	880	Level.
Total . . . . .	30	1240	

The Tunnel under Liverpool was constructed in seven or eight separate lengths, each communicating with the surface by means of perpendicular shafts. About half-a-mile from the tunnel the railroad crosses Wavertree-lane; half-a-mile to the north of Wavertree, at Olive Mount, there is an excavation through the solid rock, 70 feet below the surface, and two miles in length. The road is then carried by means of a great embankment, varying from 15 to 45 feet in height, and from 60 to 135 feet in breadth, at the base, across a valley at Roby, or Broadgreen, two miles in length. It then crosses the Hayton turnpike road a little past Roby; six miles and three quarters from Liverpool, there is a junction railway for the conveyance of coals from the neighbouring mines on the right, and at a distance of seven or eight miles from the Liverpool station, it comes to the Whiston inclined plane, which is one mile and a half long, and rises about 1 in 96.

There is stationed here an assistant locomotive to aid the carriages in their ascent. For nearly two miles the road is then on an exact level. It was on this part of the road that the contest of locomotive carriages, for the premium of 500*l.*, took place in October, 1830, the result of which determined the directors to make use of locomotive engines instead of stationary ones. About half a mile from the Whiston plane, at Rainhill, the Liverpool and Manchester turnpike road crosses the railway, at an angle of thirty-four degrees. On leaving the level at Rainhill, the railway crosses the Sutton inclined plane, which is of the same extent as that at Whiston, and descends in the same proportion that the other rises; there is here another assistant engine.

The next object of interest is Parr Moss, the road over which is formed principally of the clay and stone dug out of the Sutton inclined plane, and extends about three quarters of a mile. The moss was originally about twenty feet deep, and the embankment across it is nearly twenty-five feet high, though only four or five feet now appear above the surface, the rest having sunk below it. The road is then carried over the valley of Sankey, by means of a massive and handsome viaduct, consisting of nine arches, of fifty feet span each, the height of the parapet being seventy feet above the Sankey canal in the valley beneath. The viaduct is built principally of brick, with stone facings, and the foundations rest on piles of from twenty to thirty feet in length, driven into the ground. The breadth of the railway between the parapets is twenty-five feet. The viaduct is approached by a stupendous embankment, formed principally of the clay dug from the high lands surrounding the valley. A little to the south of the town of Newton the railway crosses a narrow valley, by the short but lofty embankment of Sandy Mains, and a handsome bridge of four arches, each of forty feet span, under one of which passes the Newton and Warrington turnpike road. The Wigan and Newton branch here enters the railway.

A few miles beyond Newton is the great Kenyon excavation, from which above eight thousand cubic yards of clay and sand were dug out. The Kenyon and Leigh junction railway here joins the Liverpool and Manchester line, and as it also joins the Bolton and Leigh line, brings into a direct communication Liverpool and Bolton. The Liverpool and Manchester railway then passes successively under three handsome bridges; and a little beyond Culcheth, over the Brosely embankment, which is about a mile and a half in length, and from eighteen to twenty feet in height. It then passes over Bury-lane, and the small river Gless or Glazebrook, and a river at Chat Moss. This is a huge

bog, comprising an area of about twelve square miles, so soft that cattle cannot walk over it, and in many parts so fluid that an iron rod laid upon the surface would sink to the bottom by the effects of its own gravity. It is from ten to thirty-five feet deep, and the bottom is composed of clay and sand. Hurdles of brushwood and heath are placed under the wooden sleepers, supporting the rails over the greatest part of the moss, and the road may be said to float on the surface. The most difficult part was on the eastern border, extending about half a mile, where an embankment of about twenty feet in height was made, and many thousand cubic feet of earth sank into the moss and disappeared before the line of road approached the proposed level. At length, however, it became consolidated; in 1829 one railway was laid over the whole moss, and on the 1st of January, 1830, the Rocket steam-engine, with a carriage and passengers, passed over it. The line extends across the moss, a distance of about four miles and three quarters; and the road is not inferior to any other part of the railway.

On leaving Chat Moss, the road passes over the lowlands at Barton, extending about a mile between the moss and Worsley canal by means of an embankment; it is carried over the canal by a neat stone viaduct of two arches. It then proceeds through Eccles, and a portion of Salford, under six bridges; it is carried over the Irwell by a handsome stone bridge of sixty-three feet span, thirty feet from the water; and then over twenty-two brick arches, and a bridge over Water-street to the company's station in Water-street, Manchester, a distance of thirty-one miles from the Liverpool station. The railway is there on a level with the second story of the Company's warehouses.

The following general abstract of the expenditure upon the work, up to 31st May, 1830, showing the cost of the different branches of the undertaking, may be found useful for comparison with the cost of more recent works of the kind:—

Advertising account . . . . .	£332	1	4
Brick-making account . . . . .	9,724	4	4
Bridge account . . . . .	99,065	11	9
Charge for direction . . . . .	1,911	0	0
Charge for fencing . . . . .	10,202	16	5
Cart establishment . . . . .	461	6	3
Chat Moss account * . . . . .	27,719	11	10
Cuttings and embankments † . . . . .	199,763	8	0
Carrying department, comprising account expended in land and buildings for stations and depôts, warehouses, offices, &c., at the Liverpool end . . . . .	£35,538	0	0
Expended at the Manchester station . . . . .	6,159	0	0
Side tunnel . . . . .	2,485	0	0
Gas-light account, including cost of pipes, gasometer, &c. . . . .	1,046	0	0
Engines, coaches, machines, &c. . . . .	10,991	11	4
		<u>56,219</u>	<u>11 4</u>
Carry forward . . . . .	£405,399	11	3

\* The embankments included under this head consist of about 277,000 cubic yards of raw moss earth, in the formation of which, about 677,000 cubic yards of raw moss have been used; the difference in measurement being occasioned by the squeezing out of the superabundant water, and consequent consolidation of the moss. The expenditure on this part of the line has been less than the average expenditure.

† Under this head is comprised the earth work on the whole line, exclusive of the Chat Moss district. The cuttings somewhat exceed the embankings; the surplus is principally deposited along the border of the Great Kenyon Cutting. The excavations consist of about 722,000 cubic yards of rock and shale, and about 2,006,000 cubic yards of marl, earth, and sand. This aggregate mass has been removed to various distances, from a few furlongs to between three and four miles: and an inconsiderable portion of it has been hoisted up by machinery, from a depth of thirty to sixty feet, to be deposited on the surface above, either to remain in permanent spoil banks, or to be afterwards carried to the next embankment.

Brought forward . . . . .	£405,399	11	3
Formation of the road* . . . . .	20,568	15	5
Rail account . . . . .	67,912	0	0
This expenditure comprises the following items:—			
Rails for a double way from Liverpool to Manchester, with occasional lines of communication, and additional side-lines at the different depôts, being about 35 miles of double way = 3,847 tons, at prices averaging something less than 12 <i>l.</i> 10 <i>s.</i> per ton . . . . .	£48,000	0	0
Cast-iron chairs, 1,428 tons, at an average of 10 <i>l.</i> 10 <i>s.</i> . . . . .	15,000	0	0
Spikes and keys to fasten the chairs to the blocks, and the rails to the chairs . . . . .	3,830	0	0
Oak plugs for the blocks . . . . .	615	0	0
Sundry freights, cartages, &c. . . . .	467	0	0
Interest account (balance) . . . . .	3,629	16	7
Land account . . . . .	95,305	8	8
Office establishment . . . . .	4,929	8	7
Parliamentary and law expenditure . . . . .	28,465	6	11
Stone blocks and sleepers † . . . . .	20,520	14	5
Surveying account . . . . .	19,829	8	7
Travelling account . . . . .	1,423	1	5
Tunnel account . . . . .	34,791	4	9
Tunnel compensation account . . . . .	9,997	5	7
Waggons used in the progress of the work . . . . .	24,185	5	7
Sundry payments for timber, iron, petty disbursements, &c. . . . .	2,227	17	3
Total . . . . .	<u>£739,185</u>	<u>5</u>	<u>0</u>

About 100,000*l.* more were required to complete the work.

In the formation of the railway, there have been dug out of the different excavations upwards of three millions of cubic yards of stone, clay, and soil; which is equal to, at least, four millions of tons!

After mature consideration of the reports and calculations of various engineers, appointed to consider the most eligible description of power for the Manchester and Liverpool railroad, they determined in favour of locomotive engines, provided they could be made sufficiently powerful, and at the same time not of so great a weight as to injure the stability of the rails, and without emitting smoke, which is one of the provisions of the Railway Act. With the view also to obtain, if possible, an engine of improved construction, a public reward was offered by the directors in April 1829, for the best locomotive engine, subject to certain stipulations and conditions, which may be thus briefly stated: viz. to consume its own smoke: to be capable of drawing three times its own weight, at ten miles an hour, and with a pressure not exceeding 50*lbs.* upon the square inch on the boiler: two safety valves, one locked up: engine and boiler to be supported on springs, and rest on six wheels if it should exceed 4½ tons: height to top of chimney not more than 15 feet: weight, including water in boiler, not to exceed 6 tons; but preferred if of less weight: boiler, &c. proved to bear three times its working pressure: pressure gauge provided: cost of machine to be not more than 550*l.*

\* By this is understood what is termed ballasting the road,—that is, depositing a layer of broken rock and sand, about two feet thick; viz. one foot below the blocks, and one foot distributed between them, serving to keep them firm in their places. Spiking down the iron chairs to the blocks or sleepers, fastening the rails to the chairs with iron keys, and adjusting the railway to the exact width, and curve, and level, come under this head of expenditure.

† Out of thirty-one miles, eighteen are laid with stone blocks, and thirteen with wooden sleeper of larch; the latter being laid principally across the embankment and across the two districts of moss.

On the day appointed, the following engines were entered for trial for the prize; and the judges appointed to decide were, Mr. Nicholas Wood, of Killingworth, (to whose labours we stand much indebted in this article,) Mr. Rastrick, of Stourbridge, and Mr. Kennedy, of Manchester, who made judicious arrangements.

The <i>Rocket</i>	Steam locomotive, by Mr. Robert Stevenson.
The <i>Novelty</i>	ditto . . . by Messrs. Braithwaite & Ericsson.
The <i>Sans Pareil</i>	ditto . . . by Mr. Timothy Hackworth.
The <i>Perseverance</i>	ditto . . . by Mr. Burstall of Edinburgh.
The <i>Cyclopede</i>	Horse locomotive, by Mr. Brandreth of Liverpool.

The trial, as before mentioned, took place on the level at Rainhill. Several days were employed in getting them into the best working condition for the contest.

	Ton.	cwt.	qr.	lb.
The <i>Rocket</i> weighed . . . . .	4	5	0	0
Tender, with water and coke . . . . .	3	4	0	2
Two loaded carriages attached . . . . .	9	10	3	26
<b>Total weight in motion . . . . .</b>	<b>17</b>	<b>0</b>	<b>0</b>	<b>0</b>

The rate of performance of this engine was found by the judges to be 70 miles in about five hours, or 14 miles per hour; with an evaporation of 114 gallons per hour, and a consumption of coke of 217lbs. per hour. The greatest velocity attained was on the last eastward trip, the 1½ mile being accomplished in 3' 44", which is at the rate of 24½ miles per hour.

On the following day the next engine brought up to the starting post was the *Sans Pareil*, but on weighing, it was found to exceed the condition of 4½ tons upon four wheels, therefore could not strictly compete for the prize. Nevertheless, it underwent a trial of its powers, in order that the Directors might be acquainted with its merits.

	Ton.	cwt.	qr.	lb.
The weight of the <i>Sans Pareil</i> . . . . .	4	15	2	0
Tender with water and fuel . . . . .	3	6	3	0
Three loaded carriages attached . . . . .	10	19	3	0
<b>Total weight in motion . . . . .</b>	<b>19</b>	<b>2</b>	<b>0</b>	<b>0</b>

In making the eighth trip on the running ground, the pump that supplied the water to the boiler became disordered in its action, by which the level of the water in the boiler became reduced below the fire tube, and the leader plug, employed as a safety valve, was melted, and put an end to the experiment. But as far as the experiment was conducted, which extended to 27½ miles, the performance was creditable, being 19½ tons conveyed at the rate of 15 miles per hour. The greatest velocity attained was in the fifth trip; the 1½ mile being traversed in 3' 59", which is at the rate of 22½ miles per hour. The consumption of the coke in this engine was enormous, being at the rate of 692lbs. per hour, which was found to be owing to the draft through the fire-place being so powerful, as to blow red-hot cinders out of the chimney shaft.

The *Novelty*, which was not tried until the 10th, owing to unavoidable circumstances, carried its own water and fuel; and, therefore, to place it on the same footing as the other engines, the same proportion of useful load was assigned to it when compared to the engine, as the useful loads taken by the other engines have to their weight. The power and its load were accordingly as follow :—

	Ton.	cwt.	qr.	lb.
Weight of the <i>Novelty</i> , with water in the boiler . . . . .	3	1	0	0
Tank, water, and fuel . . . . .	0	16	0	14
Two loaded carriages attached . . . . .	6	17	0	0
<b>Total weight in motion . . . . .</b>	<b>10</b>	<b>14</b>	<b>0</b>	<b>14</b>

In the early part of the trial with this engine, the water supply-pipe burst,

and put an end to the experiment for that day. Two or three days afterwards the trial was renewed, but another unfortunate accident (that of one of the joints of the boiler giving way) terminated the proceedings, at the desire of Mr. Ericson, who voluntarily withdrew his carriage from the contest. The performance of the engine, while it lasted, indicated very excellent results; the design, arrangement, and execution of the work, were likewise highly creditable to the genius and talent of the proprietors.

The *Perseverance*, after a short trial, was proved unsuited to the railway, and was immediately withdrawn by the proprietor. The course was thus left clear for Mr. Stevenson to receive the fairly won prize of 500*l.*, which was awarded to him by the judges.

The *Cyclopede*, though included in the foregoing list of rival machines, not being propelled by the power mentioned in the "stipulations and conditions," it could not be properly considered as entering the lists for the prize therein proposed; it was, however, an inquiry well worth the investigation, what degree of power horses could exert in a locomotive machine of the kind, and thereby determine its comparative economy with that of steam. For these reasons a trial of the *Cyclopede* took place; but it only attained a speed of five or six miles an hour, owing, as we believe, to the horses not having sufficient power to exert themselves in their stalls, as well as to an injudicious construction of some parts.

To discover the cause of the great increase of speed, and the variable quantities of fuel consumed by the different locomotive engines, which competed for the prize at the Manchester and Liverpool railway, Mr. Wood instituted the comparative view of each, which is exhibited in the following table:—

Names of Engines.	Area of Fire-grate in feet.	Area of radiant Surface, in feet.	Area of communicative Surface, in feet.	Cubic feet of Water evaporated per hour.	Pounds of Coke required to evaporate a Cubic Foot of Water.
Rocket . . .	6.	20.	117.8	18.24	11.7
Sans Pareil .	10.	15.7	74.6	24.	28.8
Novelty. . .	1.8	9.5	33.		
Old Engines.	7.	11.5	29.75	15.92	18.34

"In examining the above, we find a very important effect in the economy of fuel, produced by the *Rocket* over the old engines, in the proportion of 11.7 to 18.34, supposing the heating powers of coke and coal be equal. The cause of this is very obvious, and is entirely attributable to the use of the tubes of small diameter, presenting such an area of surface to the water in the boiler. These tubes were used at the suggestion of Mr. Booth, treasurer to the Liverpool and Manchester Railway Company, and nothing, since the introduction of those engines, has given such an impulse to their improvement.

"With a less area of fire-grate than the old engines, the surface exposed to the radiant heat of the fire is as 20 : 11.5, and the surface exposed to the communicative power of the heated air and flame, as 117.8 : 29.75, nearly four times as great.

"Nor is this the only difference; in the old engines the *area* of the tube (of 22 inches diameter) for the passage of the flame and heated air to the chimney, was 380.13 inches; and of this large body of flame and air passing through the tube, only an extent of surface of 69.11 inches was exposed to the water in the boiler. In the *Rocket* engine, the area of heated air and flame in 25 tubes, 3 inches each in diameter, was 176.7 inches, while the surface exposed was 235.6 inches.

"It is not necessary, perhaps, to pursue the comparison further. The economy of fuel which must result from the exposure of so much greater surface to the water, cannot fail to insure a more perfect abstraction of the heat, and thus

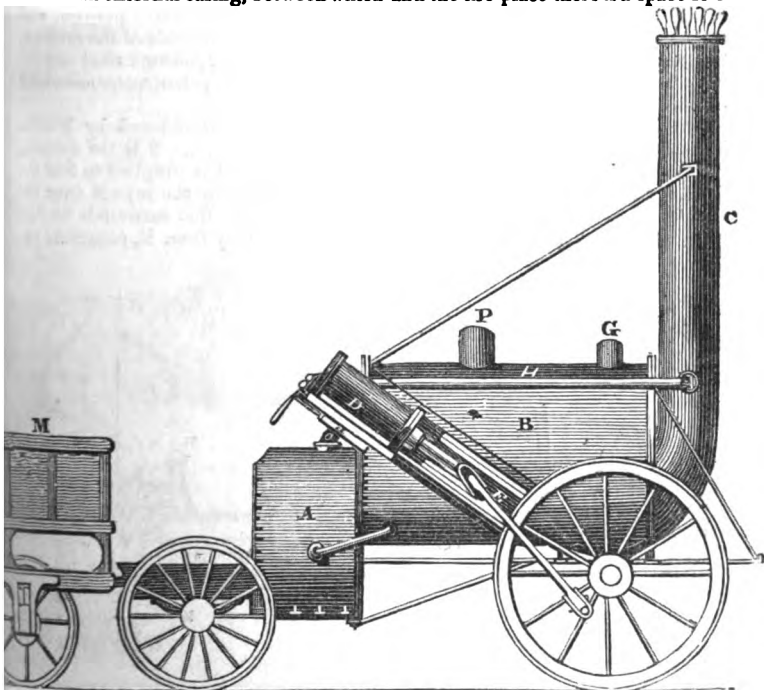
not only save the fuel, but prevent great part of the previous destruction of the chimney, by the intense heat of the *wasted* caloric.

“The same remarks apply to the *Sans Pareil* of Mr. Hackworth, as to the old engine, though in a less degree. In the *Rocket*, the surface exposed to the radiant heat of the fire, compared with the area of fire-grate, is as  $3\frac{1}{2} : 1$ , while in the *Sans Pareil*, it is only  $1\frac{1}{2} : 1$ ; the same proportion as in the old engines. In the *Rocket*, the surface exposed to the heated air and flame, compared with the area of fire-grating, is as  $19\frac{3}{4} : 1$ ; while, in the *Sans Pareil*, the proportion is only  $7\frac{1}{2} : 1$ . The bulk of air passing through the tube of the latter, will, at its exit into the chimney, be 176.7 square inches, the exposed surface being 47.12, or  $25 : 1$ , nearly; while, as before stated, the bulk of air passing through the tubes of the *Rocket*, is 176.7 inches, or precisely that of the *Sans Pareil*, while the surface exposed, is 235.6 inches, or  $1\frac{1}{4} : 1$ . These will sufficiently account for the great difference in the economy of fuel between the two engines, the *Rocket* requiring only 11.7 lbs. to convert a cubic foot of water into steam, while the *Sans Pareil* required 28.8 lbs.”

Having now stated the results of this memorable contest, it becomes necessary to give some account of the machines engaged therein.

The *Rocket*, constructed by Mr. Stevenson, of which an external side elevation is given in the following figure, possesses many of the characteristics of the engines previously used; but the furnace and boiler have considerable claims to novelty and effectiveness.

The furnace at A is a square box, about 3 feet wide and 2 feet deep. This furnace has an external casing, between which and the fire-place there is a space of 3



inches filled with water, and communicating by a lateral pipe with the boiler. The heated air, &c. from the furnace passes through twenty-five copper tubes, 3 inches in diameter, arranged longitudinally on the lower half of the boiler, and then enters the chimney C. D represents one of the two steam cylinders,

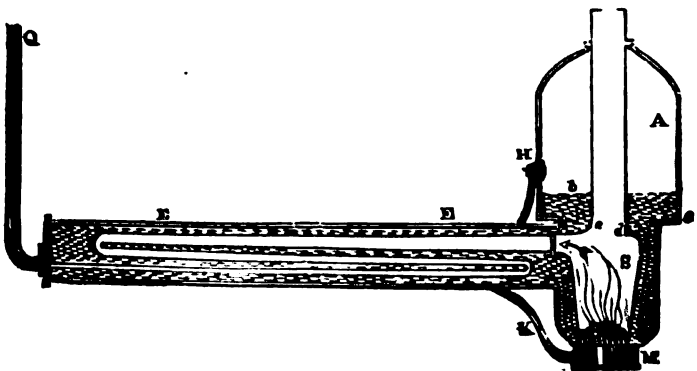


which are placed in an inclined position on each side of the boiler, and communicating by their piston rods, through the media of connecting rods E, motion to the running wheels. P G are safety valves; E is one of two pipes on each side of the boiler, by which the eduction steam from the cylinders is thrown into the chimney, and by the exhaustion thus caused in the latter, producing a rapid draft of air through the furnace. At M is exhibited part of the tender, which carries the fuel and water for the supply of the engine.

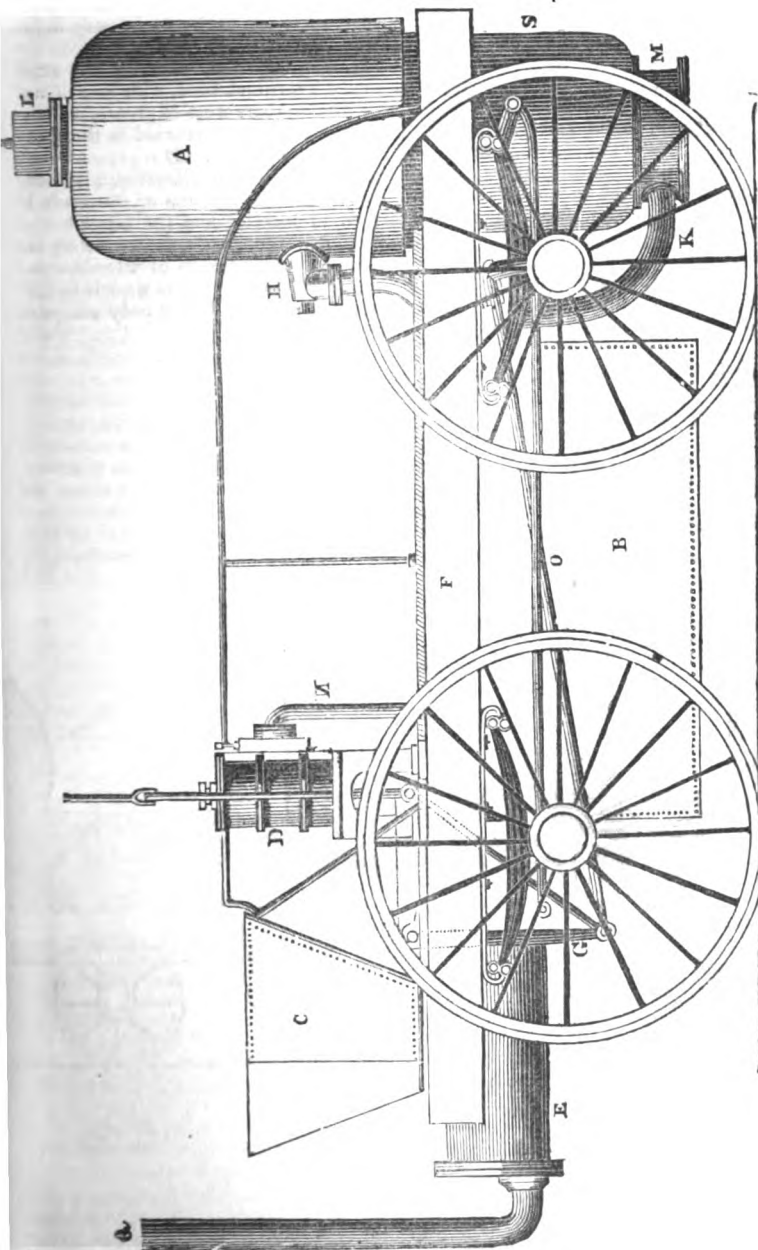
The *Novelty*, by Messrs. Braithwaite and Ericsson, is exhibited in the opposite page, representing a side elevation of the machine.

F is the carriage-frame; E, one end of a long horizontal cylinder, forming the principal part of the boiler, which extends to the large vertical vessel A, at the other end of the carriage, and contains forty-five gallons of water; L, a hopper to supply the fuel, (which is carried in small baskets placed on the carriage,) whence it is conducted by a tube in the centre of the steam-chamber A, into the furnace S, beneath. At C is a blowing machine, the air from which is conducted by a pipe under the carriage, and proceeding by the tube K enters the ash-pit M, under the furnace; Q is a pipe for the escape of the heated gases after the combustion, and forms the only chimney used; B is the water-tank; at D N are two working cylinders with their steam-pipes and valves; the cylinders are six inches in diameter, and have a twelve inch stroke; O G are connecting-rods, which impart the force of the engines to the running-wheels. The axletrees are fixed to an iron rod, and slings are introduced to prevent the side action between the rod and the carriage-frame; and to prevent the effect of the springs from counteracting the action of the engine, the connecting-rods are placed as nearly as possible in a horizontal position, and the motion is communicated to them by bell-cranks on each side of the carriage, being connected by the slings to the piston-rods. The pistons used are the patent metallic of Barton; and the running-wheels, the patent suspension kind of Theodore Jones and Co.

The figure below exhibits a section of the boiler introduced by Messrs. Braithwaite and Ericsson, into the *Novelty* steam-carriage. S is the furnace, surrounded by water; and L the tube by which the fuel is supplied to feed the fire; M is the ash-pit, through which the air is forced by the pipe K from the bellows of the engine. The vessel containing the water that surrounds the furnace, and the long cylinder that proceeds horizontally from it, constitute the

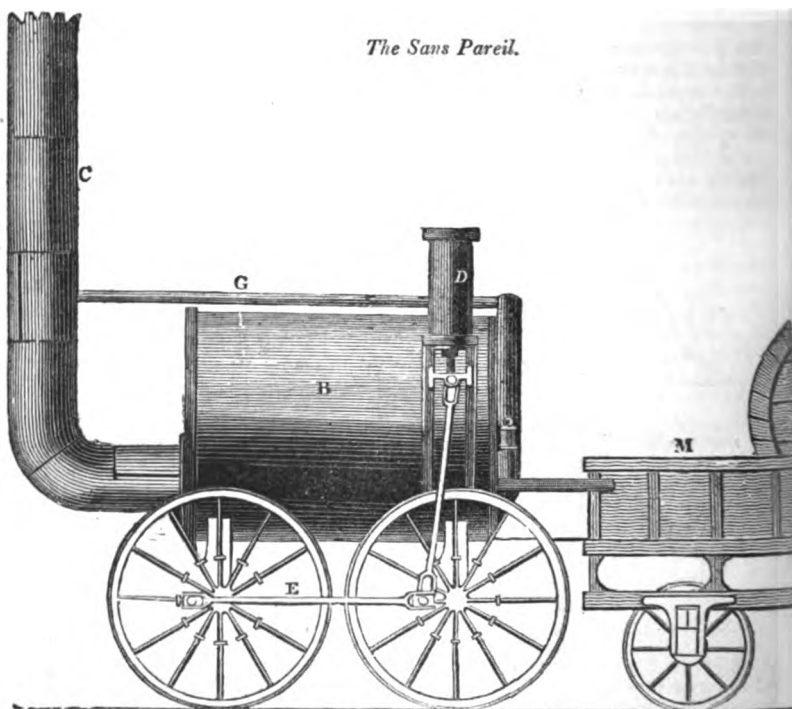


boiler, as shown at E E *s*. The flames and heated air from the furnace, after ascending by the action of the bellows, enter a long tortuous flue, which makes three turns in the entire length of the horizontal boiler, escaping finally at the chimney. The fuel in the furnace has, therefore, a direct action upon the water surrounding it; and the water in the long cylinder is operated upon by the



gases in the flue, which gradually tapers from the furnace to the chimney, and has a constant inclination downward; and as the whole of the furnace and flue is surrounded by the water of the boiler, there can evidently be very little of the heat misapplied.

The *Sans Pareil* of Mr. Hackworth is represented in elevation in the subjoined cut. The boiler B is cylindrical, of the Trevithick kind, with one of its ends convex outwards, and the other flat. The fire-bars were of greater extent than usual, having an area of ten feet; and the flue-tube is returned to the front on one side of the fire-place, where it enters the chimney C. D represents one of the two working-cylinders; these were seven inches in diameter, and had an eighteen-inch stroke. The piston rods, through the medium of the vertical connecting rods, operated upon the hind pair of wheels; and the latter being connected to the fore wheels by the horizontal connecting rods, shown acting in the manner of cranks, motion was communicated to both pairs of wheels,—an arrangement which is designed to cause a greater adhesion of the wheels to the rails, and of enabling the carriage to draw a greater load, than if only one pair of wheels was operated upon.



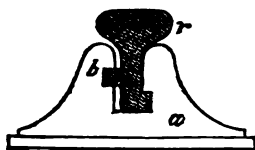
## SECTION II.

## THE CONSTITUENT PARTS OF RAILWAYS.

Stephenson's and Losh's Rails and Chairs.—Jessop's Chairs and Pedestals.—Stephenson's patent Chairs and Fastenings.—Scrivenor's patent wrought-iron Chairs.—Reynold's patent continuous Bearing-rails and Sleepers.—Parkins's patent Vitrified Sleepers.—Permanent way of the Great Western Railway.—Permanent way of the South Eastern Railway.—Brighton and Hastings permanent way.—Oral's patent Chairs and Sleepers.—Switches.—Curtis's patent Switches.—Turntables.—Hancock's patent Turntable.—Mallet's hydrostatic Turntable.—The broad and narrow Gauges.—Parliamentary Commission thereon.—Inconvenience of breaks—as applied to Passengers—to Merchandise—and to Troops.—Expedient of Telescopic Axles.—Loaded waggons on Trucks.—Shifting on Wheeled Platforms.—Intermediate Rails.—Policy of uniformity of Gauge.—Comparative safety of different.—Accommodation and convenience.—The best adapted for speed.—Accidents on each.—Economy of each.—Deductions from the evidence.—Recommendations to Parliament.—Water Crane.—Cleansing Rails.—Curtis's Screw Jack.—Cost of various Railways per Mile.

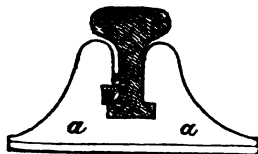
The general nature and construction of Railways having been explained and illustrated in the previous Section, we proceed, in this division of our subject, to give a more enlarged and precise description of their constituent parts; especially as relates to the improvements in such as have been devised since the opening of the Manchester and Liverpool Railway.

We shall commence with a brief account of the rails, chairs, and sleepers used by Mr. Stephenson in the formation of the Manchester and Liverpool Line, which was omitted in our account of that Railway.



the opposite side, and locks the bar into its required position.

The annexed cut shows a transverse section of the rail *r*, which has a lateral rib on one side, fitting into a corresponding cavity made in the cast-iron chair *a*. On the opposite side of each chair another cavity is cast, to receive an iron key *b*, wedge-formed, which, pressing against the side of the rail, forces the projecting rib into the cavity on



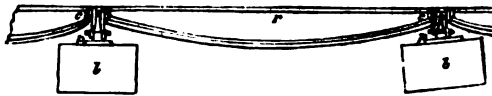
projection on the rail to force it down upon the chair and against the side of the rail to steady it, and force the projection on the other side of the rail into the cavity. By this mode of keying it was considered, that if the rail worked loose upon the chair, by driving the key, it could be tightened.

**JESSOP'S PATENT CHAIRS AND PEDESTALS.**—To obviate the inconvenience frequently resulting by the sleepers or blocks sinking in the soil or losing their perpendicularity; and hence of destroying the level or parallelism of the rails, Mr. Jessop patented in 1833 a method of framing the chair distinct from the pedestal; the latter being fixed firmly to the sleeper, and the chair being united to the pedestal by a universal joint or hinge. This arrangement permits the pedestal to adapt itself to any irregular sinking of the block or sleeper on which it rests, and insures a firm and solid bearing upon its base. The patentee

also effects it by the combined motion of a hinge joint, or other means permitting motion between the pedestal and the chair, and a moveable joint formed at the junction of the chair and rail, so as to produce the same effect. The following drawings represent several methods of constructing the universal joint, in all of which *rr* are the rails, *cc* the chairs, *pp* the pedestals, and *bb* the blocks or sleepers; *jj* are the junction bars of cast or wrought iron, by which the opposite chairs are connected together, and the rails are thereby held parallel to each other, and at a proper distance apart, and are also retained in a suitable position to insure a flat bearing on the surfaces of the rails for the wheels to travel upon; *ss* are cast-iron bed-plates or sleepers, (which may be used to support the rails where stone is expensive,) so constructed that the pedestal may be readily adjusted, by the introduction of a wedge or packing, to a proper level, without disturbing the seats which the bed-plates may have acquired on the ground; the same method of construction being applicable to the pedestals, when they are attached to stone blocks.

*Fig. 1* is a side view of its adaptation to the ordinary railway in use in the north, at the period of the invention.

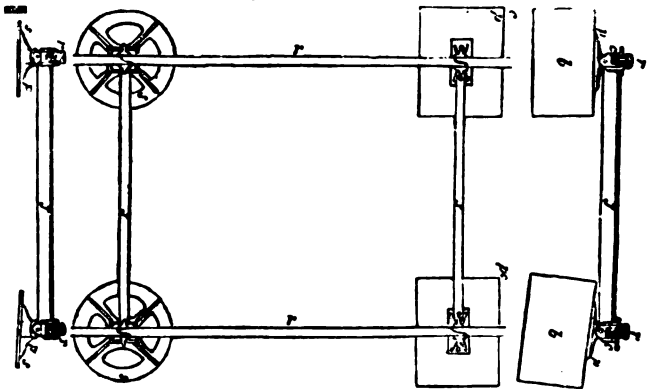
Fig. 1.



*Fig. 2* shows the plan; and *Fig. 3*, the cross section. Two of the stone blocks *b* are drawn in an inclined position to show the action of the pedestal.

Fig. 2.

Fig. 3.



*Figs. 4* and *5* are sections of the pedestal and chair, showing an orbicular universal joint, by means of which the pedestal adapts itself to any irregular sinking of the stone block or other sleeper, whilst the connecting or junction bars retain the rails in their proper gauge, and their opposite surfaces in the same plane or straight line.

Fig. 4.

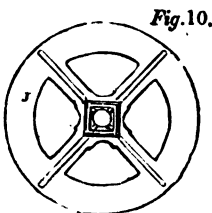
Fig. 5.



*Figs. 6, 7 and 8, are other views of the pedestal and chair.*



*Figs. 9, 10 and 11, are a side view, plan, and section of a cast-iron bed-plate, used as a substitute for the stone blocks; showing also the method of adjusting the rails by means of wedges or packings introduced between the bed-plates and the base of the pedestal, which is made to fit in the recess formed in the bed-plate, and secured laterally by means of a wedge or key. The patentee states his claim to consist in "constructing railways, to the using of chairs and pedestals, which are capable of turning or moving on universal or other similar joints, as above described, whereby the railway will not be so liable as heretofore to be deranged by the sinking of the blocks or sleepers, whether of stone, wood, iron, or other material."*



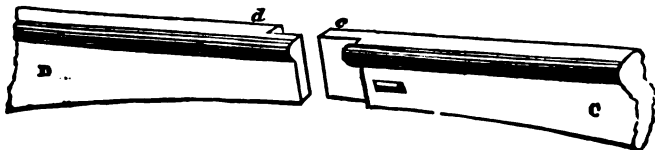
**STEPHENSON'S PATENT CHAIRS AND FASTENINGS.—**  
Owing to the effects of expansion and contraction, and the violent shocks and strains to which the fastenings of a railway are subjected, the task of perfecting these parts of the mechanism has until recently been found one of difficult accomplishment. With the view of remedying the defects then existing, Mr. Robert Stephenson obtained letters patent in 1833 for certain modes of providing "firm and secure bearings at the bottoms of the notches in the chairs for the rails to rest upon, these bearings being capable of self-adjustment, in order that they may adapt themselves correctly to the under parts of the rails; and the making of adequate provisions for fastening the iron rails securely downwards, upon such self-adjusting bearings, as well as for confining the rails laterally within the notches in the chairs, but in such manner that the self-adjusting bearings will not be subject to be deranged, nor the fastenings to be loosened, by the effect of any such slight tilting or inclination of the chairs in the direction of the length of the rails, as may result from the partial or unequal subsidence of the ground beneath the stone blocks or wood sleepers upon which the chairs are fastened, nor by the effects of any such slight elongations or contractions in the length of the rails as they are usually liable to from ordinary changes of temperature."

Mr. Stephenson's mode of effecting this, is by the application of a self-adjusting segmental bearing piece, into a suitably formed concavity made below the level of the bottom of the notch of each chair; the flat or chord side of the segmental piece being uppermost, and forming the bearing surface at the bottom of the notch in the chair. Upon that flat bearing surface, the under side of the rail is to rest, so that the bearing surface will always accommodate itself to the under side of the rail, and form an even contact therewith; in consequence of the circular side of the segmental piece adapting itself to the required position, by turning in its concave cell. Having thus explained the general arrangement of the parts, it will not be requisite to enter into the minutiae introduced into the specification, as sufficient knowledge will be obtained by the insertion of the following illustrated figures, and description of them:—

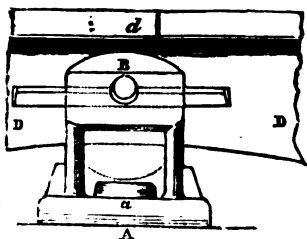
*Fig. 1 is a perspective view, and Fig. 2 a lateral elevation; Fig. 3 a transverse section, and Fig. 4 a horizontal plan of a chair, for supporting and uniting the extremities of the lengths of iron rails for edge-railways. A A is the flat*

bottom or base of the chair, which is to be bedded upon the block or sleeper, and fastened thereto by spikes driven through the holes *a a*.—*B B* are the cheeks of the notch in the chair, that notch being the parallel space which is left between the cheeks for the reception of the rails *C c D d*, which may join together with a half lap joint, as shown in perspective at *Fig. 1*, and in the plan *Fig. 4*, the overlapping parts *c d* being of the same size, or nearly of the same size, as the other parts of the rails, and those parts are included within the

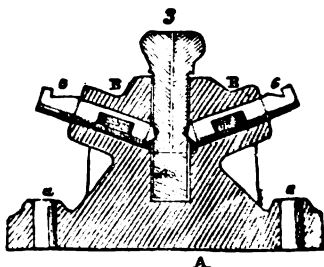
*Fig. 1.*



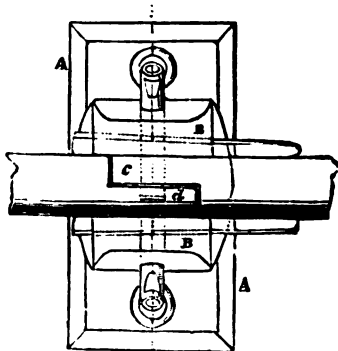
*Fig. 2.*



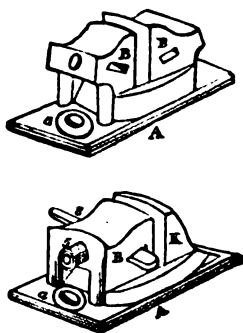
*Fig. 3.*



*Fig. 4.*

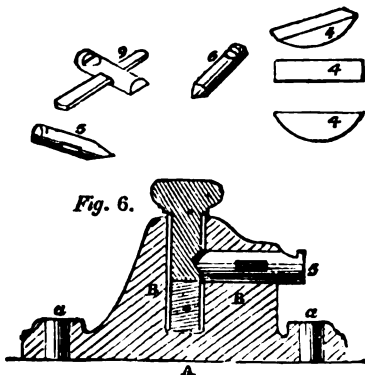


*Fig. 5.*



notch of the chair. The bottom of this notch is deeper than is necessary for receiving the rails, and is depressed into a concavity of a suitable form, for receiving the segmental bearing-piece which is shown on the next page, at 4 4 4, in plan, elevation, and perspective: the under edges of the rails rest upon the uppermost flat surface of this bearing-piece. The small figures 5 and 6 are cylindrical pins, which are fitted into cylindrical sockets, through each of the cheeks or sides *B B*; and 8 and 9 are tapering or wedge-like keys, which are inserted through suitable mortices in the cheeks and across the pins 5 and 6,

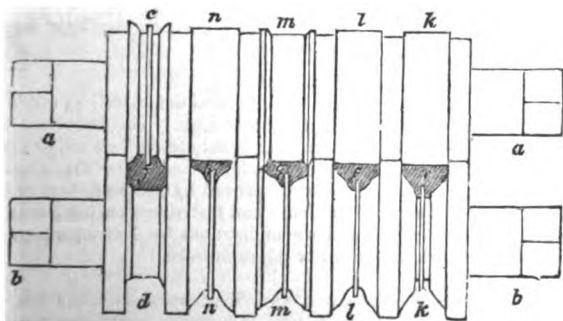
for the purpose of forcing forward those pins, so that their pointed extremities may press obliquely upon the lower parts of the grooved recesses in the rails, with a bearing-down action, to confine the rails downwards upon the bearing-piece, and laterally in the chair. The cylindrical pins are shown detached, in order to explain the manner in which the pointed extremity applies into the grooved recess in the rails, so as to exert a bearing-down action thereon. *Fig. 5* represents perspective views, and *Fig. 6* a transverse section of a chair for



supporting the iron rails at intermediate distances between the extremities or junctions of their several lengths; it has only one cylindrical pin 5, fitted through one of its cheeks B, the opposite cheek K being a flat vertical surface, against which the flat side of the rail is pressed and held firm, by the keying up of the cylindrical pin 5, so as to confine the rail laterally at the same time that the oblique action of the point of the cylindrical pin 5, in the grooved recess of the rail, may produce a bearing-down action, which confines the rail down upon the segmental bearing-piece. The chairs are made of cast iron; the sockets for the cylindrical pins, the mortices for the wedge-like keys, and the cells for the segmental bearing-pieces, being formed in the casting, as well as the holes for the holding-down spikes; the wedge-like cross keys, the cylindrical pins, and the segmental bearing-pieces, are made of wrought iron.

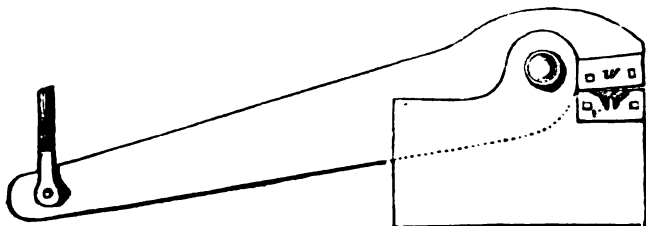
**SCRIVENOR'S PATENT WROUGHT-IRON CHAIRS.**—The extensive destruction of the ordinary *cast-iron* chairs about fifteen years since, induced Mr. Scrivenor, in 1832, to attempt their formation of malleable iron by the rolling and die-pressing process. The following account we derive from the specification of the patent.

*Fig. 1.*



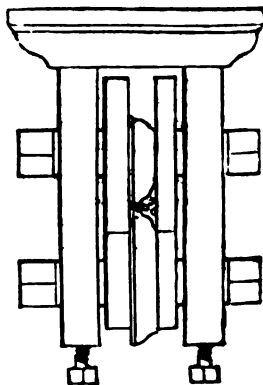


In the preceding *Fig. 1*, *a b* represent a pair of cast-iron rolls designed for this object, and put in motion by the usual mechanism employed in iron-works. It will be observed that the series of grooves or indentations in their peripheries correspond with the several shapes which the metal is intended to take in its progress through these rollers, until it at length attains the exact shape required to form the chairs or pedestals. Thus, for example, the grooves at *c d* must be adapted to receive an ordinary short thick bar of wrought iron, about two feet long, and six inches square, properly heated for rolling. The bar is first passed through the rollers at *c d*, which causes it to assume the shape shown at *j*. It is then passed in succession through the other grooves on the rollers at *k k*, *l l*, *m m*, *n n*, whereby it successively takes the form shown at *e f g h*. Having thus obtained a long bar of iron of the sectional form shown at *n*, it is next cut into lengths for chairs, which is effected by the mill shears shown at *Fig. 2*, which are worked by the engine. These shears are provided with steel jaws to receive the chair as shown at *v w*, in order that in cutting off the chair it may not be forced out of shape. The opening between the cheeks of

*Fig. 2.**Fig. 3.*

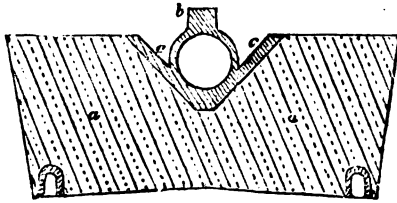
the chair for the reception of the rail are at present left parallel; the next process is therefore to give these parts a more suitable form for holding down the rail. This is effected by making the chair red hot, and placing inside the recess a mandril of the required shape, with which it is again passed through another pair of rolls shown in the annexed *Fig. 3*; by these the recess is impressed with the required form to adapt it for receiving the intended keys.

We have never seen any of the wrought-iron chairs of the kind just described in use; probably from the difficulty of bestowing upon them that finished form which is requisite, at a sufficiently low price. Although the brittleness of cast-iron seems at first sight to render it an improper substance for chairs, yet a little reflection on the other hand will show that it affords such facilities to the judicious engineer to provide the most effectual remedy to its natural defect, as to render it in our opinion even more advantageous than wrought-iron. The immense breakage of cast-iron chairs a few years since was in a great measure owing to injudicious forms, and not a little to bad execution in the foundries, rather than to the nature of the material. This fact is satisfactorily proved by the perfection of form and superior execution of the cast-iron chairs and fastenings on the South Eastern and Dover Railway, manufactured we understand by Ransome and May of Ipswich, which will be described a few pages onward.

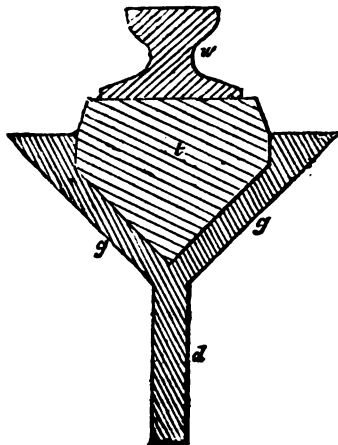


REYNOLDS'S CONTINUOUS BEARINGS AND SLEEPERS.—It has been observed that the deflection of the railway bars, by heavy carriages passing over

them, absorbs a considerable portion of the tractive force; besides producing, by their vibratory action, an earlier destruction of the stationary, as well as the locomotive mechanism. To provide a remedy for these apparent defects of the ordinary system, Mr. John Reynolds, of Neath, proposed to give to the rails, bars, or plates, an equal support in every part of their length, so that they shall not be susceptible of sensible depression or deflection; and this he proposed to effect by two methods, for which he obtained a patent on the 5th May, 1835. The first is by cast-iron bearers laid and joined end to end, and in such manner as to be incapable of vertical or lateral movement, independently of those next adjoining to it. The rails, bars, or plates, over which the carriage-wheels are intended to run, may be either cast on and with the bearers, or they may be separate. The second method is by bearers formed by blocks of natural or artificial stone, joined end to end, and bedded in the roadway, and secured in such manner together, that they can only move in concert. A great variety of forms of rails, founded upon the basis of construction just mentioned, have been made by Mr. Reynolds: it will only be in our power to notice here two or three of them. The annexed figure shows a vertical section of one of the most approved forms, in which the ballasting that it is imbedded in, shown at *a a*, is of less depth than the bottom of the stone sleepers generally used, and of considerably less depth than the bottom of the excavation and ballasting on the London and Birmingham railway.



The form of the bearing rail for the carriage wheels is shown at *b*, and that of the hollow support and lateral inclined plates at *c c*. They are fastened end to end by means of "snugs," or projecting pieces cast to them, of such forms that, when placed in juxtaposition, a key or wedge driven into an aperture formed by their union, which holds them firmly together. The blocks of natural or artificial stone are to be joined by the various modes known to masons, and too well understood to need explanation. The annexed section represents another of the numerous designs given by the patentee: *w* represents a wrought-iron rail, resting upon and fastened to a sill of timber *t*, enclosed between the bearing plates *g g*, which, together with the fin *d*, are imbedded in the ballasting.



The advantages contemplated by the patentee are—1, a great saving in excavation and ballasting; 2, a saving of the cost of materials and laying down; 3, in maintenance of way or permanence of work; 4, saving the repairs of engines. Some rails on this construction are laid down experimentally on the Liverpool and Manchester line, and apparently stand the test very satisfactorily.

**PARKINS'S PETRIFIED SLEEPERS.**—Mr. Thomas Parkins, of Dudley, took out a patent for a similar object to the foregoing, in December 1835. It consists in forming continuous sleepers of vitrified earth (burnt clay), which the patentee states are as hard and durable as granite, and impervious to the weather. The

following *Fig. 1* gives a cross section of Mr. Parkins's railway, and *Fig. 2* a side elevation of a portion of it. The vitrified blocks or sleepers are shown at *a a a*; each sleeper is 13 inches at the base, 5 at the top, 12 deep, and 9 long, and locks into the other, thus forming a continuous mass along the whole line of road. The joining is effected by a projecting tongue *b*, which fits into a corresponding recess made in each block. A groove *c* is moulded longitudinally in the top of the sleepers, into which the rib of a wooden bearer *d* (four inches at the base, four deep, two wide at the top, and twelve feet or more long) is placed; and is bedded upon patent felt; on this wooden bearer is fixed an iron bar *e e*, for the wheels of the carriages to run upon; this bar or rail being also bedded upon felt.

Fig. 1.

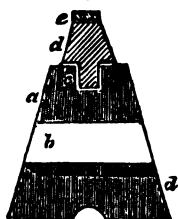
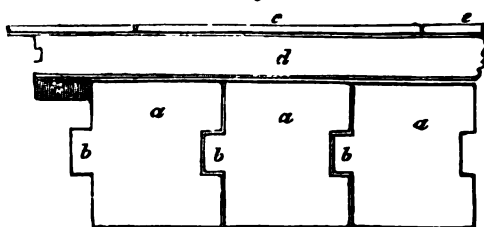


Fig. 2.



Mr. Parkins gives the preference to the arrangement described; but he proposes, in certain cases, to dispense with the wooden bearers *d d*, and to place iron rails of the ordinary kind at once into the groove *c*.

**PERMANENT WAY OF THE GREAT WESTERN RAILWAY.**—This line of rails is laid down throughout upon continuous bearings, but the method of connecting the rails to those bearings, and of connecting the latter to the transverse sleepers, or rather ties, is varied in different parts of the line. There are other variations which our space will not permit us to enter upon, we have therefore selected for our illustration that particular modification of the permanent way, to which we understand Mr. Brunell gives the preference.

Fig. 1.

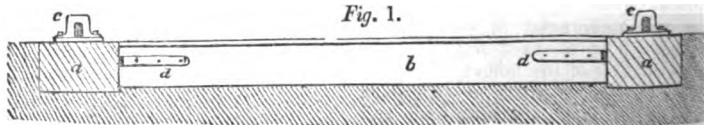
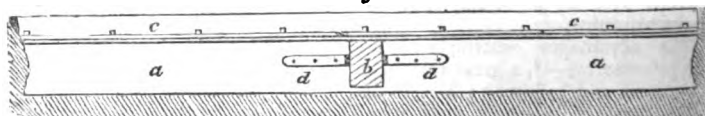


Fig. 2.

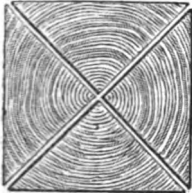


*Fig. 1* represents a transverse section of the permanent way; and *Fig. 2* a longitudinal view. At *a a* are the longitudinal bearing timbers having a scantling of about 15 × 9 and joined continuously through the line. These timbers are united together at right angles by transverse ties *b b*, at about every 9 feet distance; these are also of timber, about 6 inches by 9, and fastened by means of straps and bolts *d d*. These ties preserve the parallelism of the continuous bearings. On the upper surface of the latter are laid thin boards of prepared hard wood, and fastened thereto by nails. The width of these boards is about 8 inches, and on them is laid the continuous rail, in lengths of about 15 feet each, end to end throughout. The form of these rails is that often denominated the "hog trough" or "bridge" rail; the shape is however pretty

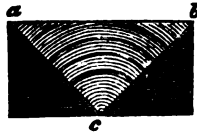
well indicated in *Fig. 1*, at *c c*. The same rail is shown in our account of the Brighton and Hastings permanent way, on a larger scale. Mr. Brunell was the inventor of this form of rail, and it is undoubtedly a very efficient one.

**PERMANENT WAY OF THE SOUTH-EASTERN RAILWAY.**—The chairs, fastenings, and sleepers employed on this line of railway are entitled to the particular attention of the engineer, on account of the good judgment and skilful execution displayed in the details of the work; combining, as they appear to do, durability of structure with economy of material. A description of this permanent way was furnished to the Institution of Civil Engineers, by Mr. John Pope, Grad. Inst. C. E. from which we shall make such few extracts as we have room for.

On either side of the bank of ballast, and below the level of its bed, there is an open drain, three feet in width, extending throughout the line, which ensures perfect drainage from beneath the sleepers. The sleepers are placed transversely, and differ in shape from any hitherto employed. They are of Baltic fir, and are formed by a square balk being diagonally divided so as to cut out four triangular sleepers, which are laid with the right angle *c* downwards, which form

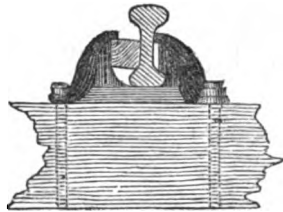


Square balk divided to form four sleepers.



Triangular sleeper *a b c*, contrasted with half a balk.

(*a b c*) has as much bearing surface as one of twice the cubic content cut out as a half balk in the usual manner. The advantages arising from this form in the economy of timber, the facility of packing, and the improved drainage of the ballast in contact with the sleepers, are obvious. The chairs are of a peculiar form, designed by Mr. Cubitt to combine lightness with strength; they are cast on a plan invented and patented by Messrs. Ransome & May, of Ipswich, whereby the inward inclination of the rails, instead of being made to depend merely upon the rail layers, (as is usually the case) is effected entirely by the shape of the cavities, which are all cast with peculiar accuracy. The uniformity of inclination attained by this improvement greatly diminishes that lateral motion of the carriage which is commonly observed on other lines of railway. The chairs are placed horizontally on the sleepers, and are fastened down with trenails of oak, compressed by the patent process of Messrs. Ransome & May.



Elevation of Chair, showing the inclination of the Rail.

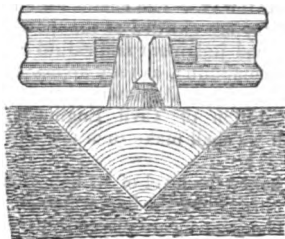
The wedges employed to secure the rails in the chairs are similarly compressed. The rails are parallel, with their upper and lower tables of equal breadth, the sectional form of which is shown in the previous figure.

The subjoined four figures (p. 422,) exhibit the end elevation and plan of a joint chair, and the end elevation and plan of an intermediate chair, which, considered in connexion with the preceding *side* elevation of the chair, will, it is hoped, render the peculiar form understood.

Mr. Cubitt's object has been to lay a railway entirely upon transverse sleepers, of such a form as would expose the largest amount of bearing surface for the least portion of timber; that the bulk of the ballast should be beneath the bottom of the sleeper, where alone it is useful; to use only the best foreign timber; to have the rails rolled uniform and sufficiently heavy; the chairs

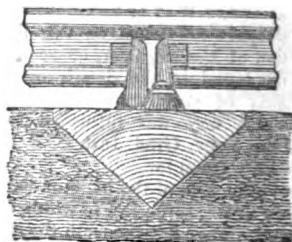
simple in form, possessing great regularity, and giving the inward inclination to the rail within the chairs, instead of depending upon the rail layer doing so

*Joint Chair.*

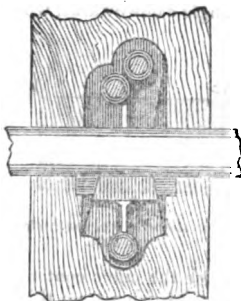


*End elevation.*

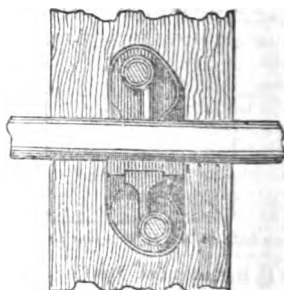
*Intermediate Chair.*



*End elevation.*



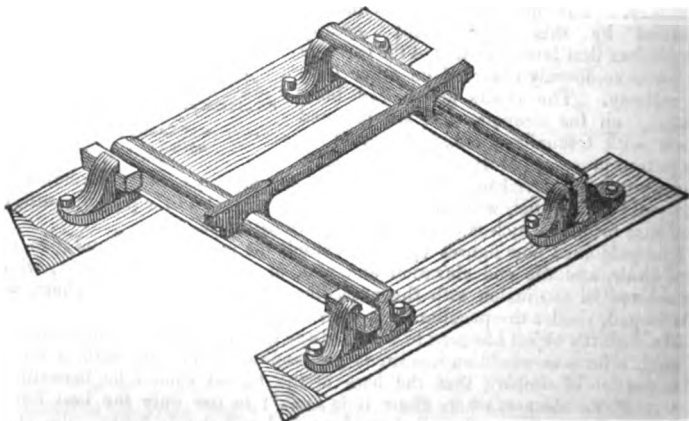
*Plan.*



*Plan.*

when fixing them on to the sleepers; and that the fastenings should be simple, but firm, and not liable to breakage, or to be detached by the passage of the carriages.

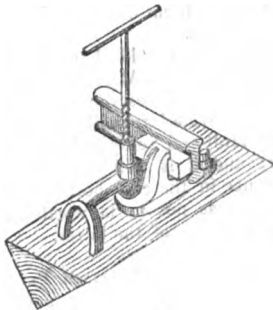
With these views he had directed four sleepers to be cut out of each square log of foreign timber, giving about  $2\frac{1}{2}$  cubic feet to each sleeper; to place them with the right angle downwards, so that the ballast could always be consolidated



*Rails, Chairs, and Sleepers, with the clamp gauge fixed.*

by ramming, without lifting the sleeper, or digging around it, as with square, or other formed sleepers; two places are planed to receive the chairs, and one fastening-hole bored in each sleeper: they are then Kyanised in close tanks, completely filled with the prepared solution, under a pressure of 80 lbs. per square inch. When placed upon the ballast, the joint chairs are first put down 15 feet apart, and the intermediate chairs three feet apart; "cramp gauges" embracing the inside and outside of the rails, are then fixed between each pair of sleepers, and the wedges along one side driven up—one treenail being driven in each chair, the hole for which is previously bored in the sleepers by a gauge, to insure an equal projection on each side of the rail.

A "guide tube" of an internal bore to fit the spiral auger for boring the treenail holes, with the external lip tapered to correspond with the hole in the chair for the head of the treenail, is then used, and by its agency the holes are pierced with great accuracy, concentric with the hole in the chair, at the same time protecting the tool from being injured by the cast-iron. The intermediate chairs are then fixed in the same manner, and the operations are repeated for the opposite rails; the ballast is then consolidated by ramming. In this manner the work proceeds very rapidly; the ballast supports the sleepers throughout, and has no tendency to fall away from them; the water drains away freely; and the passage of the ballast waggons (though without springs) over the new made portion of the line was found to be productive of benefit, rather than injury.



*Guide Tube, and Spiral Auger, in use.*

The inclination of the rail being given by the shape of the chair, insures so much accuracy, that after one day's traffic over it, the surface of the rail is rubbed equally throughout, and not alternately on either side, as is commonly the case.

The uniformity of surface produced is, we think, in a great measure due to the surpassing excellence of Messrs. Ransome & May's castings, which appear to be executed in the highest style of the foundry art, presenting externally a highly finished appearance; and the dye-like accuracy of their internal form is obtained by the introduction of nicely fitted metallic cores. Mr. Pope describes the mode adopted by the patentees of casting these chairs to be "by placing an iron plate on each side of the pattern, ramming them up in sand and using an iron core, which being sustained in its position by a projecting tongue falling into a groove in the side plates, preserves an uniform inclination of the rails in the chairs." Extraordinary precision is thus obtained, and only about 2 per cent. of waste castings are made, although they are subjected to a rigid test; for if the bearing points allow the rails to vary 1-16th of an inch from the required inclination, they are broken up. The iron cores do not unduly chill the metal, and the average strength is retained. The iron used is chiefly "Welsh Cold Blast."

The peculiarity of the system of the compressed wooden wedges and treenails as fastenings to railways consists (as explained by Mr. May) in subjecting the fibre of the timber to compression equally from the circumference to the centre. The pieces of wood for the wedges are cut out with parallel sides, and forced by hydraulic presses into tapering moulds; whilst in those moulds they are subjected to the action of heat, applied through the medium of low pressure steam; after being allowed to cool, they are forced out of the moulds, and so long as they are kept dry they retain their compressed form; but as the operation simply contracts the dimensions of the sap vessels without crushing the fibre, the power of capillary attraction is not destroyed, and when the wedge is driven into the chair and exposed to moisture they swell so as to become and remain

perfectly tight. There is this difference between wedges so compressed and all others; that a true wedge is obtained from a piece of wood cut parallel on all sides, whilst all former modes produced not wedges but parallel pieces.

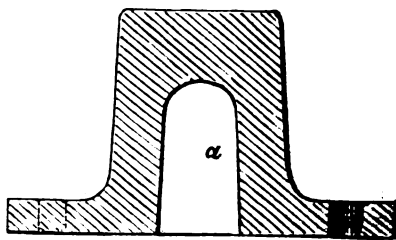
The diminution of the bulk of the treenails by this process of compression, is from 100 to 63, and of the wedges from 100 to 80. It is found that the wood does not swell until it is placed in a damp situation, as in the sleepers. Even the most solid woods, such as African teak, can be compressed without sustaining injury. Perfectly seasoned timber will not shrink after compression, but green wood will shrink after the process. One of the principal advantages of the compressed treenails is the firmness with which they hold into the sleepers. Around the iron spikes generally used, a sheath of rust is formed by the damp sleeper; the shaking of the carriages tends to draw them upwards; and the elasticity of the fibre around the hole in the sleeper being impaired, it is of no use to drive them down again in the same place, and the chairs eventually become loose.


It is proper to add that Mr. Cubitt disclaims the invention of the angular formed sleeper, as Mr. Reynolds used it before him for his longitudinal bearing rails; but he believes transverse sleepers of that form had not been used previously.

*Uncompressed* treenails for fastening down the chairs to the sleepers were used in the Hull and Selby railway; in the Dublin and Drogheda and many other lines; and it is well known that these frequently become loose. Yet the difference in the cost between these and Messrs. Ransome & May's must be so trifling as not to be worth a moment's consideration, when compared with the advantages of the latter.

**BRIGHTON AND HASTINGS PERMANENT WAY.**—The sectional form of railway bars are now for the most part much alike; and similar to that previously described as appertaining to the South-Eastern line: the variations consisting only in some slight differences in the proportions or curves. The only marked distinction which has fallen under our observation is the form employed on the Great Western, the London and Brighton, and a few other lines. This form may be described as a regular four-sided prism with a flange on two opposite sides for bolting it down to the sleepers or other supports; an illustration of which is afforded by the following cut, which is explanatory of the permanent way of the Brighton and Hastings Railway.

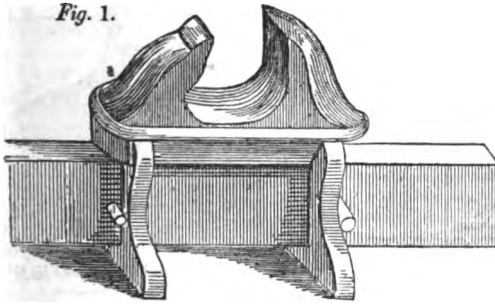
The marginal figure represents the rail in section; it is drawn to a scale of four inches to the foot, from which it appears by calculation to weigh about 80lbs. per yard; affording that degree of strength and stability which the present experience of railway engineers has dictated the necessity of. There is considerable stiffness in this configuration. Over the flanges it is fully six inches wide, and affords thereby a very useful bearing surface on the ballast, on which it is supported, except at the sleepers, which are imbedded in the ballast.



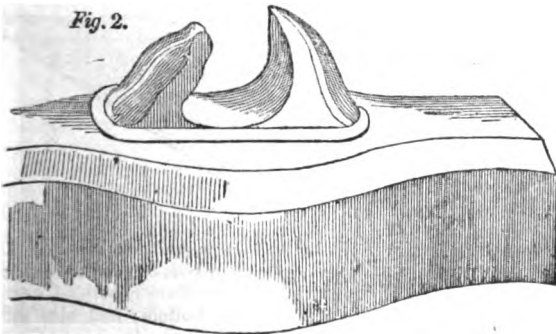
There are no longitudinal bearings to the rails or sleepers, but simply a series of transverse sleepers *b c* at the usual distance of three feet apart. There are two sorts of sleepers used, joint sleepers *c* and intermediate sleepers *b*; the former are Baltic deals 8 feet long, 4½ inches thick, and 14 inches wide; the latter 8 feet long, 4½ inches thick, and 9½ wide. On the two joint sleepers only where the ends of the rails *a a* are brought together, there are put what are called chairs *d d*, consisting merely of a square piece of thick sheet iron turned up at the edges thus . Into these chairs the ends of the rails are put, and spikes driven through all three; namely, the flanges of the rail, the "chair," and the joint sleeper. Between every two joint sleepers there are usually three intermediate sleepers *b*, and to these the rail is fastened by a half-headed spike

(shown at *e*) not through holes made in the flanges, but so that the overhanging half-head shall just clip over the edges of the flanges. How such a structure can be expected to last for a month, under the ordinary strains and concussions of railway traffic, is to us a matter of surprise.

**ORSI'S PATENT CHAIRS AND SLEEPERS**—Mr. Orsi's patented improvements in sleepers and blocks for supporting the rails consist in forming the sleepers of metal, imbedded in cement or other plastic material, so as to defend the metal from the action of the air and moisture; and afford a large bearing surface. *Fig. 1*



represents perspective a cast-iron chair to which is cast on the under side a pair of lugs, having a large rectangular aperture in each, through which is passed a bar, and fastened thereto by the two pins shown. The bar is a substitute for an ordinary transverse sleeper, and the two chairs are thus fixed at the required gauge apart with great facility and truth, and possess great firmness and durability. After the chairs and bars have been thus united they are to be imbedded in a bituminous cement up to the lower side of the chairs. In the annexed *Fig. 2* one of a pair of chairs is shown so imbedded in cement; the other chair of the pair being supposed to be connected with it on the left



hand side; the union being effected by what may be termed a metallic sleeper, rendered indestructible by its bituminous encasement.

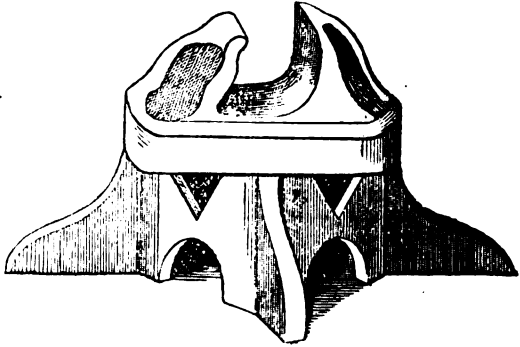
Sleepers or blocks formed of cement, carrying the chairs so braced together, are intended to be placed transversely at suitable distances apart, along the line of the intended railway; and when they are firmly secured to the ground, the rails are to be fixed to the chairs in the ordinary way.

In the following engraving is represented one of Mr. Orsi's chairs, which is cast in one piece with the winged and other projections shown. This is subsequently to be imbedded in asphalt or other cement, so as to form a block or sleeper with a broad incorrodible base. The cement in a fluid state is poured

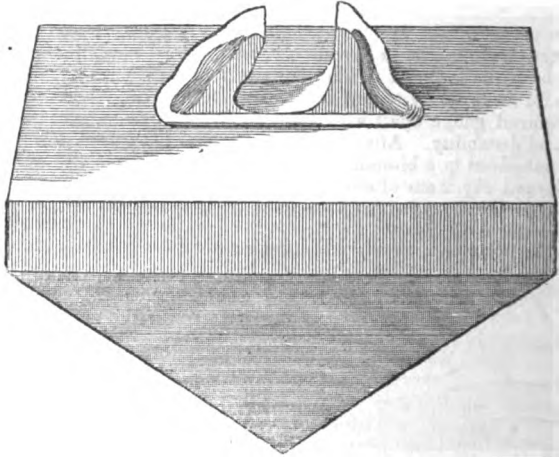




into a mould containing the metallic chair and its support, and hardens as it cools into a solid mass. The subjoined figure shows one of the patentee's chairs imbedded in a block of cement, and of the shape indicated. These examples



of Mr. Orsi's invention will suffice to give an idea of the modifications which it is susceptible of when taken in conjunction with the following summary of his

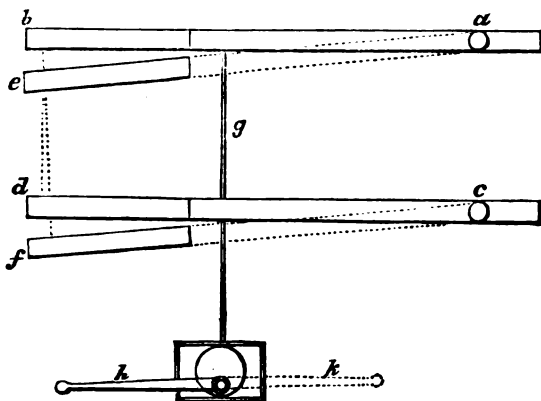


claims made in the specification, which are expressed as follow.

"*Firstly*, constructing the sleepers of bars or rods of metal, which are passed through the under part of the railway chairs, and are imbedded in cement, so as to form blocks, having broad surfaces at bottom; and also the peculiar construction of chair for embracing or holding the bars or rods, as above described and shown in the drawing. *Secondly*, imbedding in cement blocks of wood braced by transverse tension rods, so as to form sleepers, upon which the ordinary chairs for railways may be fixed by bolts, screws or nails. *Thirdly*, fixing chairs for railways in blocks of cement to form sleepers, by imbedding projections or wings at the lower parts of such chairs in the plastic material, connecting two such blocks or sleepers together by transverse rods, attached to the metal chairs. And *lastly*, constructing longitudinal sleepers for railways by means of stout planks of wood, combined with iron bars or rods, placed side by side, and imbedded in cement so as to form a continuous block, upon which the rails may be fastened down, without employing chairs."

**SWITCHES.**—In order to enable railway trains to pass from one line of rails to another as becomes necessary on various occasions, at certain parts of the line small portions of the rail are formed of bars, termed switches, which are moveable upon a pivot at one end of the bar. Various arrangements of switches have been proposed, or are in operation, depending partly on the nature of the service for which they are required, some of which are self-acting, and others require to be moved by an attendant.

The annexed figure represents a mode of passing carriages from one line of road to another, adopted by Mr. Stephenson, on the Liverpool & Manchester Railway, and described in Wood's Treatise on Railways.



Let *e f* be the road into which the carriages are to be made to pass. *a b c d* being the main line of road, two rails are made moveable upon the joints *a* and *c*: these two rails are joined together at the other end by an iron rod, which is extended to one side of the road. This end of the rod is terminated by an oblong box, as shown in the figure, and within this box an eccentric cam or wheel is placed with an upright axle, on which is fixed the handle *h*. The difference between the radii of this wheel from the centre of motion, is precisely equal to the distance between the ends of the two rails; when, therefore, the eccentric wheel is in the position shown in the figure, the carriages will pass along the main line: but on turning the handle round to *k*, and with it the eccentric wheel, the latter pushes the rod and rails into the position shown by the dotted lines. This mode of turning the carriages into another road is quite safe, and can admit of no mistake if the handle be turned sufficiently round, as the eccentric wheel is made to move it the proper distance and no further.

**CURTIS'S PATENT SWITCHES.**—Mr. W. J. Curtis's improvements in switches have come into extensive use on the Great Western, South Western, Midland Counties, and other railways.

Fig. 1, in page 428, shows a plan of switches for a single crossing. The switches may be formed various ways, but the patentee recommends the following; viz. rivetting the bars, whether two or more, to a flat plate *c* half an inch thick, 10 or 12 inches wide, and 15 feet long; the bars having a section to correspond with the rails, are rivetted to this plate *c*; one rail being bent to correspond with the curve or cross line, and the other straight to correspond with the main line (if straight), or should both be curved then both bars are curved to correspond with their respective lines: upon the back or underside the centres *r* and stud plates *o o* are rivetted.

The best shape is to make them round, with a flat face or flange, and the studs welded into them. The bed planks *h* are formed of oak planks 3 inches

thick, and at regular distances the stud plates 1 are let into the oak bed planks, rising about 1-8th of an inch above the surface, so that the iron plates ride upon the iron surfaces of the stud plates, with less friction than if they were

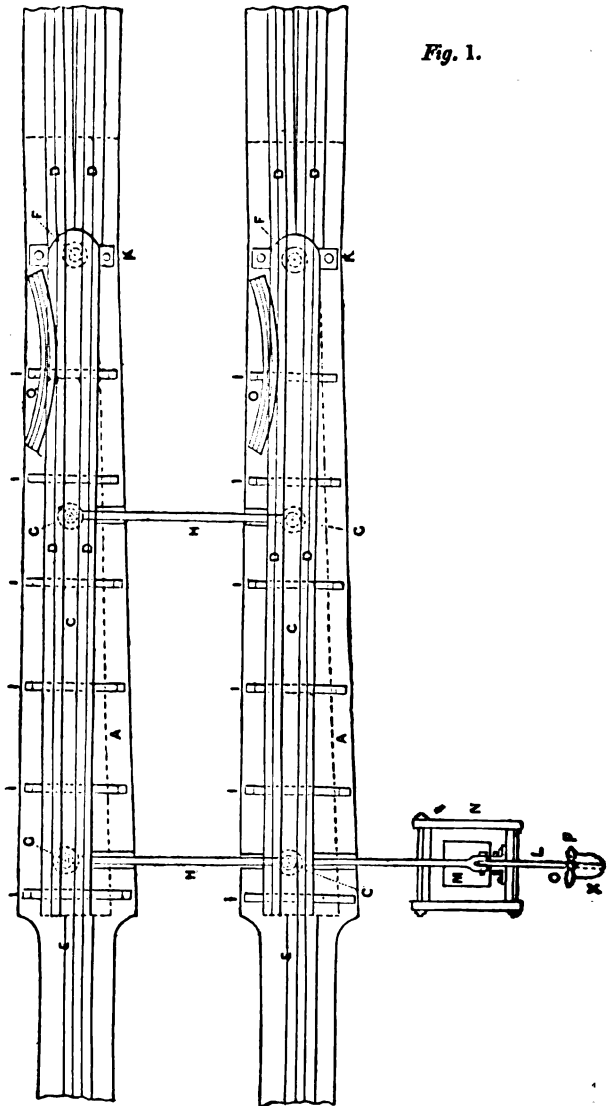


Fig. 1.

level with the timber. Towards each extremity of the stud plates studs are raised, which confine the switches within their limits of motion, and form supports against which they rest, and thus acquire a certain degree of solidity, whilst the trains pass over them. The oak planks are then let into the longitudinal

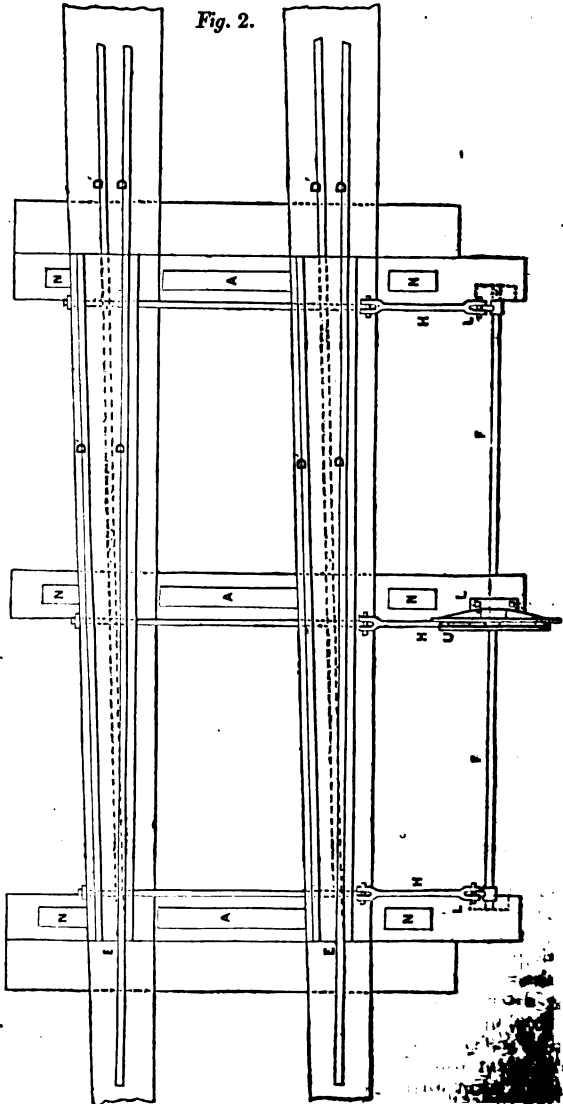
timbers of the railway, if formed upon that plan, or bolted to timber of sufficient solidity and united in the usual way with the rails, if the system of stone blocks and iron chairs be employed. A plate  $x$  forms the centre plate for the centre studs to work in; a hole is bored in it to suit the pin, and it is then bolted to the bed planks, and thus the switches are secured at the end. Two radius bars  $h h$ , connect the switches in the usual manner, the longer rod passes to the lever  $L$ , by which the movement of the switch is effected; the lever  $L$  shown in the plan, acts in the manner of a treadle, and the upright bar  $o$ , as a string or holding bar: thus, a man depresses the end of the lever  $L$ , by pressing his foot upon the flat part  $x$ , and laying hold by the cross head  $r$ , of the upright bar  $o$ , he exerts a force as if he were lifting a weight, by which means his weight and muscular force are brought into action at the same time, and he is able to lift the counterbalance weight  $m$  of nearly three hundred weight with great ease: thus a very heavy counterbalance weight may be employed to keep the switch open. The upright bar  $o$  is flexible, and formed like a spring, with a notch or stud which shuts under the lower side of the lever  $L$  when the switch is open, or right for the line, and prevents the possibility of the train opening it as it passes over it; the counterbalance weight is enclosed in the usual way, in the ground box  $n$ .  $d d d d$ , are the rails of the line, and the cross line at the head of the switch, and  $e e$  the rails at the foot of the switch. The oak bed planks are made long enough so that about 18 inches or two feet of the rails at each end lie upon it; thus making the whole steady and secure. A hand lever may be employed instead of the treadle, or any other suitable means to work the switch; also if the crossing be a compound one, or any number of turn-outs take place from one line, then each plate has rivetted to it as many bars as there are separate lines, and each bar must be bent or otherwise as before explained.

The safety-guard rail  $q$  shown in the figures, is contrived with the view of preventing an engine or train running off the rails, by the switches being placed wrong. As has been before observed, the balance weight keeps the switch right for the line, but whilst right for the line it is wrong for the cross line; in this case, if an engine were to pass along the switch of the cross, the wheel would impinge against the guard rail  $q$ , push the switch over, and make it right for that line, and when it is passed over, the switch will shut again by the reaction of the counterbalance, and keep it right for the main line as before stated.

*Fig. 2*, in page 430, shows a modification of these switches: the main features of this arrangement are the same as those of the former one, the bars being bent to the curves of the respective lines to which they belong, and the same clearance spaces left; the principal difference between the two is that in the latter case the switch has a movement transversely to the line, and not moving from a centre as before: the bars are bolted to a cross frame of timber  $A$ , held together by bolts passing through the frame, and the transverse movement of the frame is produced by the levers  $L L$ , fixed upon the lying shaft  $F$ ; to these levers are attached the connecting links  $h h h$ , connected with joints fixed in the transverse frame; then by moving the long hand lever  $L L$ , either of the bars of the switches is brought in contact with the main or cross lines at will: stopping pieces  $n n n$  are placed to confine the movement of the switch as in the case of *Fig. 1*.  $m$  is a cast-iron standard for the lever to work against, and holes are made in the segment for a pin to be inserted, to confine the lever in the usual way.  $d d d' d'$  are the bars of the switches,  $d d d' d'$  the bars of the line and cross line, and  $e e$  the bars of the line at the foot of switch.

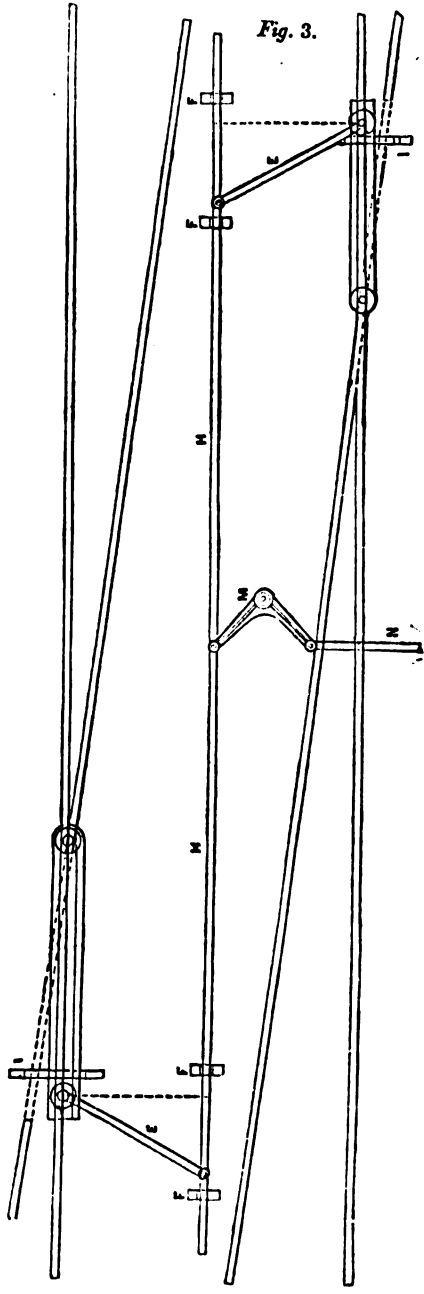
*Fig. 3*, in page 431, represents an adaptation of these switches to points or crossings. The switches are made in the same way as those previously described, except that they are shorter, the length whatever it may be being determined by the distance for clearance between the rails which may be fixed upon by the engineer, and for which 3 inches will be generally found to be sufficient. The point of contact for the foot of the switch, may be at the point where the inner edges intersect each other, or at any place between that point where the outer edges of the rails intersect each other; then measure from this point until the rails open 3 inches (or the space required for

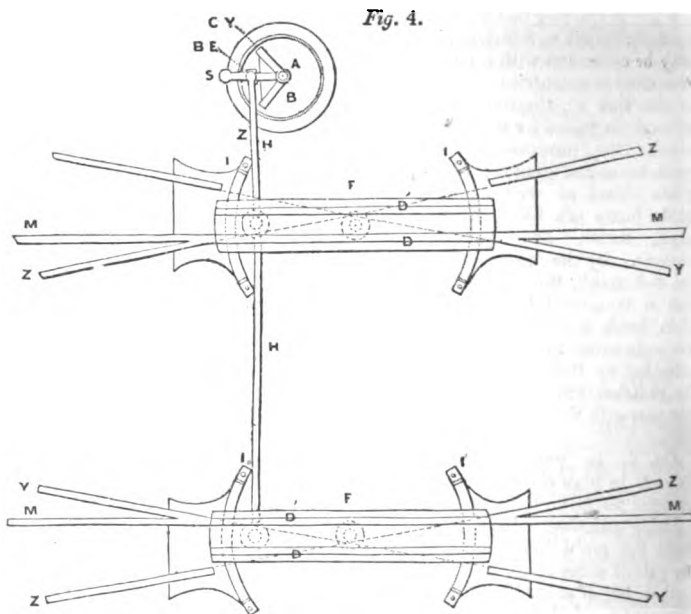
clearance) which gives the place for the head or centre end of the switch: stud or joggle pieces are placed as before described, to confine the switches within their limits of motion. The switches may be either double or single, and accordingly one is shown as single, and the other as double in the figure, but in all cases the head or centre of the switch should be placed as shown in this figure, because whichever way the switch is laid, it is held in its place by the fixed stud pieces 1, so that a train passing over the switches, has a tendency by its action to push the rails out to keep the switches the more steady.



$\kappa$  is the connecting link worked by the bell crank  $\mu$ , which crank may be connected with a lever, cam, crank, or eccentric by means of the link  $\mu$ : the rod slides through the guides  $\nu \nu \nu \nu$  which answer the purpose of the guide boxes and glands: these guide pieces as well as the guide boxes are fixed in any usual, secure, and suitable manner. By the movement of the bell crank, the connecting link  $\kappa$  is moved towards the right hand, and the rods  $\kappa \kappa$  are made to occupy the position indicated by the dotted lines: the switches are then thrown into gear with the other or cross lines.

Fig. 4, in page 432, represents in plan these switches arranged to form the points of a double crossing, where  $\mu \mu$  shows the main lines, and  $\nu \nu$  one pair of cross lines, and  $\kappa \kappa$  another pair of cross lines. The intersections of the cross lines is shown by the dotted lines; thus the bars  $d d$  alternately make the connexion with  $\nu \nu$  and  $\kappa \kappa$ : the switches are formed in the same way as those before described, and joggle or stud pieces  $i i i i$ , are provided to limit the motion of the switches as before described.  $s$  shows the circular case in which the upright shaft of the hand crank or lever works. Upon the lower end of the upright shaft a three-pronged crank is formed, and to one of these cranks or prongs the connecting link  $\kappa$  is united by a pin joint; each of these prongs catches into the latch  $e$ , as it passes over it, so that when the centre prong is held in the latch as shown in the figure, the main line  $\mu \mu$  is complete as drawn, but when the handle is moved to the one side or the other, and the switch made to complete either of the cross lines  $\nu \nu$  or  $\kappa \kappa$ , then the prong  $c \nu$  or  $c \kappa$  is held in the latch, and retains the switch in its position. The latch  $e$  is depressed by a man placing

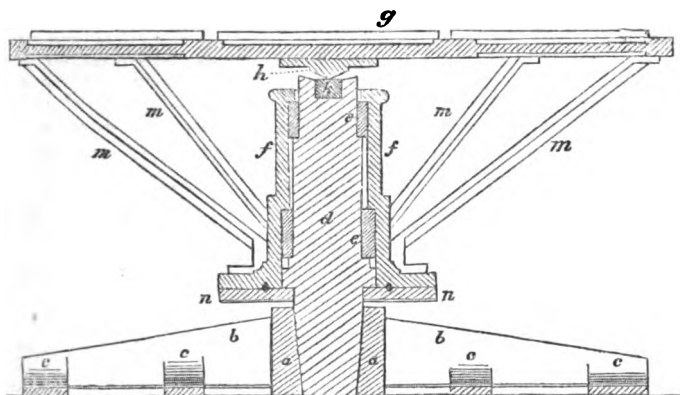




his foot upon the spring *s*, which when released raises the latch again: the rods *h h* connect the switches together, and the switches are based upon timber as before described, or are placed in a cast-iron bed-plate, or finished in any other usual and suitable manner. The centre studs *f f* work in cast-iron bed-plates.

**TURNABLES.**—In order to transfer an engine or carriage laterally to another line of rails, at a station or terminus, circular platforms called turntables are established upon each set of rails, which turn as upon a pivot in the centre of each line, each contiguous pair of tables being connected by short branch rails, standing at right angles to the line of rails. The engine or carriage to be transferred is brought to rest wholly upon one table, which is then turned a quarter round, and the carriage is then wheeled on to the next turntable, which being likewise turned a quarter round, the engine or carriage will then be in a position to proceed on the line to which the second table appertains. Turntables are variously constructed; the annexed figure (p. 433) represents a section of one which is in pretty extensive use on several railways; amongst others (we believe) the Great Western.

It is the invention of Capt. Handcock of Birmingham, who obtained a patent for it in 1840. The base plate is formed of cast iron, and consists of a deep socket *a* in the centre, from which branch several radiating ribs *b b*, which are braced together by two broad flat rings *c c*; *d* is a column or pedestal firmly keyed into the socket in a perfectly vertical position, and forming the support to the platform of the table; *e e* are loose collars of gun-metal, resting upon shoulders formed on the pedestal, which is accurately turned at those parts so as to fit the collars without shake or friction; *f* is a cylindrical tube or casing surrounding the pedestal, and collars with recesses accurately bored to fit the collars; *g* is the turning platform, having in the centre on the under side a steel pivot *h*, which rests in a steel step *k*; in the top of the pedestal *m m* are a series of struts or stays, resting upon a stout flange at the bottom of the casing *f*, and supporting the platform at the circumference. To provide for the efficient lubrication of the collars, a flat plate *n* having



metallic rings covered with leather to form a tight joint, is screwed up to the bottom of the flanch of the casing, and the space between the pedestal and the interior of the casing is filled with oil. The following cut (page 434) represents a turntable of a different description, which was invented by Mr. Robert Mallett, of Dublin, C.E.; from whose able pen an ample description of it appeared in the *Mechanics' Magazine*; we shall, however, endeavour to explain the construction in a more concise manner.

From the vertical pressure of the table being supported on a fluid, Mr. Mallet named it the "Hydrostatic Turntable."

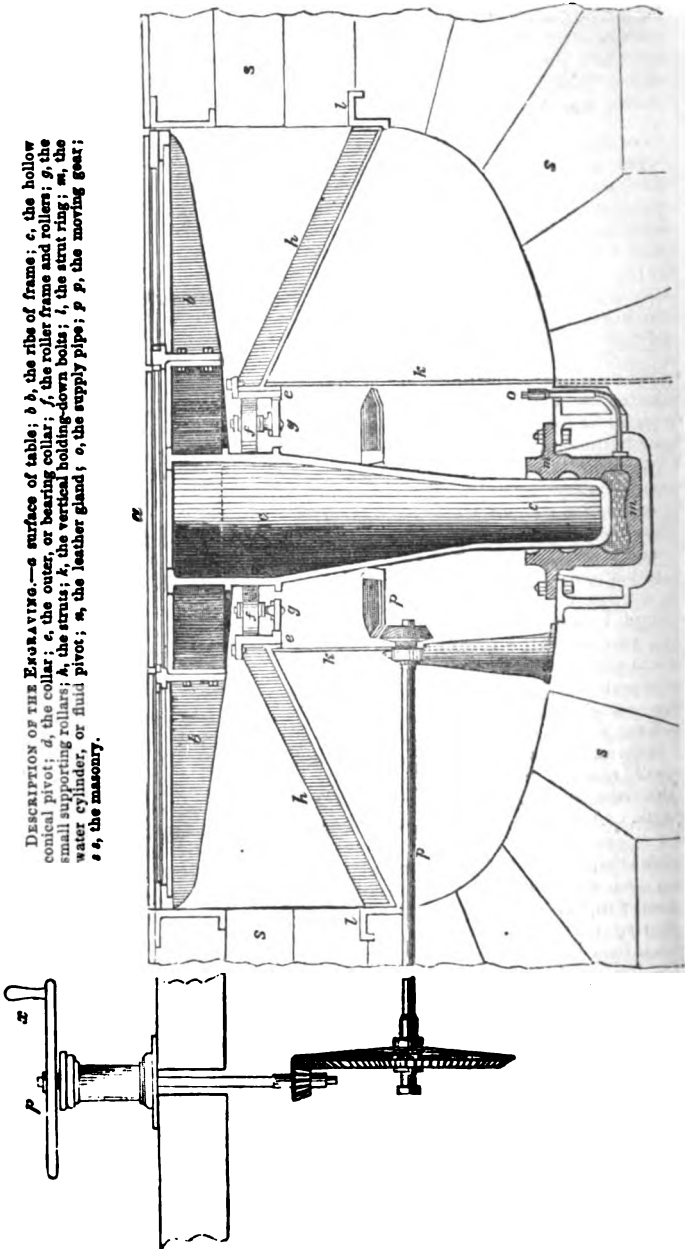
The platform *a* of this table is much the same as usual, consisting of four or more interlacing ribs *b*, of about 12 inches in depth, at the centre, connected by a ring at the circumference, and all cast in one piece. The tops of the ribs carry the crossing rails, and the interspaces are planked, or open cast-iron trellis gratings are dropped into them and rest upon a rebate. The central portion of the ribs is secured by bolts to the projecting flanches of the large vertical pillar or pivot *c*, upon and with which the whole revolves. The lower portion of this pivot, as well as a broad collar, or neck *d*, close under the platform, are turned truly cylindrical, while the form of the remainder is generally conical.

This central pillar, or pivot, is cast hollow, of thickness suitable for sufficient strength. At the same level, and concentric with the turned collar *d* of the pivot, is placed a cast-iron bored ring *e*, considerably larger in internal diameter than the external diameter of the pivot, and which is sustained in its place, and all lateral or other motion thereof prevented, by a number of diagonal struts *k*, and by four vertical bolts *k*, fitted and bolted to the outside of the ring, or "bearing collar" *e*, and also to a large concentric ring casting *l*, which is built into the side walls of the turntable pit.

The lower part of the main pivot consists of a turned cylinder, like the plunger or ram of an hydraulic press, and which, also, like the latter, drops into a strong bored cylinder *m*, of a few inches in length, prepared at its upper lip to receive a double leather collar *n*, upon Bramah's plan, so as to remain water-tight under considerable pressure; the cylinder has a close bottom, and is provided with a small tube *o*, opening into one side, and closed by a screw-plug valve of simple construction, by which the interior of the cylinder may be filled with water. The lower part of the turntable pit consists of an inverted arch, or rather dome, of brick or stone, resting upon a bed of concrete when requisite, and this small hydraulic cylinder is bedded down upon a cast-iron ring, forming the centre or crown of the inverted dome, and is secured and adjusted to the latter by means of bolts passing through a projecting flanch cast round it. To counteract the lateral pressure, when an engine is passing on to the table, is the object of the upper collar *d*, and bearing collar *e*;



DESCRIPTION OF THE ENGRAVING.—*a* surface of table; *b*, the ribs of frame; *c*, the hollow conical pivot; *d*, the collar; *e*, the outer, or bearing collar; *f*, the roller frame and rollers; *g*, the small supporting rollers; *h*, the struts; *k*, the vertical holding-down bolts; *l*, the strut ring; *m*, the water cylinder, or fluid pivot; *n*, the leather gland; *o*, the supply pipe; *p*, the moving gear; *s*, the masonry.



between these, into the annular space, left by reason of their different diameters, is dropped a circular wrought-iron frame, consisting of two rings of flat bar iron, carrying six turned cast-iron rollers, revolving horizontally between these collars, upon wrought-iron pins, which pass through and connect both wrought-iron rings. The weight of these rollers and rings is sustained by four small rollers, which are fixed as to position, and revolve vertically in pairs, cast in brackets, projecting inwardly from the turned bearing collar.

*The Broad and Narrow Gauges.*—The inconvenience arising from a diversity in the breadth of space between the two lines of rails, on one railway compared with that on another, became the subject of much discussion, and of animadversion upon Mr. Brunel's adoption of the "broad" gauge of 7 feet, on the Great Western line, in preference to the previous generally adopted "narrow" gauge of 4 feet 8½ inches, between the rails. The inconvenience is especially felt in the transfer of many kinds of goods, where the "breaks" of gauge occur, as it necessitates the unloading the waggons on one line, and reloading other waggons on the other line; and as they are of very different dimensions, and require a different plan of loading, injury often results by the shifting and unpacking of the goods; besides incurring much labour, expense, loss of time, and not unfrequently pilfering. A great variety of mechanical contrivances have been, for years past, suggested to remedy the inconvenience of the change of gauge, but none that can be regarded as equalling the advantages gained by an uninterrupted or uniform gauge.

To determine what ought to be done under these difficulties, a government commission has been appointed to inquire "whether in future acts of parliament for the construction of railways, provision ought to be made for securing a uniform gauge, and whether it would be expedient and practicable to take measures to bring the railways already constructed, or in progress of construction, in Great Britain, into uniformity of gauge, and to inquire whether any other mode could be adopted of obviating or mitigating the evils apprehended as likely to arise from the break that will occur in railway communication, from the want of an uniform gauge." The commission was dated 11 July, 1845, and consisted of the following members: Sir J. M. Frederick Smith, Lieutenant-Colonel Royal Engineers, Professor Airy, Astronomer Royal, and Professor Barlow; names in which the public deservedly place the highest confidence for their intellectual capabilities and perfect integrity.

These gentlemen called before them such persons as they deemed most competent by their situation, knowledge, or experience, to afford them correct information on the subject of their inquiry, and had produced before them such books and documents from the various railway companies as appeared to be the best calculated to aid their researches. They personally examined into the usual course of proceeding on various railways, both at home and abroad, especially those which are incident to a break of gauge. Having inspected several locomotive engines, as well as various mechanical contrivances, invented either for the general use of railways, or for obviating the special difficulties presumed to arise from the break of gauge, and having carried their investigation to the utmost useful limits, they drew up a Report, which we shall now proceed to give the substance of, in a condensed form; as all the material facts bearing upon the subject seem to have been investigated with scientific intelligence, and correct judgment, and entirely free from party bias to any of the great rival companies, whose interests are affected by the decision of the question propounded; moreover, because many of their deductions from the evidence elicited, form useful data for the guidance of railway engineers.

The attention of the commissioners was first directed to ascertain whether the break of gauge could be justly considered so great an inconvenience as to require the interference of the legislature. This important part of the inquiry is treated under the following heads; viz. *first*, as applying to fast or express trains; *secondly*, as applying to ordinary or mixed trains; *thirdly*, to goods trains; and *fourthly*, to the conveyance of troops.



1. *As applying to Fast or Express Trains*; the commissioners observe, "We believe that the inconvenience produced by a break of gauge will, in some respects, be less felt in these than in other trains, because the passengers travelling by fast trains are usually of a class who readily submit to many inconveniences for the sake of increased speed on the journey; the inconveniences of a break of gauge are reduced, in this instance, to the removal of the passengers and a moderate quantity of luggage."

2. *As applying to ordinary or mixed Trains*.—"In these trains the passengers considerably exceed in number those who travel by the fast trains, and they have generally a much greater quantity of luggage. To such travellers a change of carriage is really a serious inconvenience, and it is a well-known fact that persons travelling by railways in communication with each other, but under different managements, endeavour to make such arrangements as to admit of their travelling by those trains which afford them the accommodation of occupying the same carriage from the beginning to the end of their journey.

"The managers and directors of railways are well aware of this feeling, and in some instances accommodate the public by enabling travellers to avoid a change of carriage on the journey.

"It is by the ordinary or mixed trains that private carriages and horses are conveyed, and the removal of either from one truck or horse-box to another, at any part of the journey, would be attended with inconvenience and delay; and with regard to the horses, it would involve considerable risk.

"We arrive, therefore, at the conclusion, that the break of gauge would inflict considerable inconvenience on travellers by the trains now under consideration.

"The change of carriages, horse-boxes, and trucks, and the transference of luggage of an entire train of much extent, must, even in the day-time, be an inconvenience of a very serious nature, but at night it would be an intolerable evil, and we think legislative interference is called for to remove or mitigate such an evil."

3. *As applying to Goods Trains*.—"From the statements made to us by carriers on railways, and from our own observation, we are induced to believe, that not only a considerable degree of care, judgment, and experience is necessary in the stowage of merchandise in railway waggons, but also, that it is desirable that when properly packed the articles should, generally speaking, not be disturbed until the journey is completed. We find that in the arrangement of merchandise, the heavier goods are placed at the bottom, and the lighter at the top of the load, and so secured as to prevent friction as far as practicable from the jolting of the waggons; and it is considered very desirable with a view to prevent loss by pilfering, that the sheeting, which is placed over the load, should not be removed till the completion of the journey. Indeed, acting upon this principle, carriers find it profitable to send their waggons partially filled from various stations on the line, thereby increasing their toll to the railway company, rather than incur the risk of loss by theft, to which they would be exposed by uncovering the waggons on the journey, to fill up with intermediate local goods waggons that may have started with light loads from one of the termini.

"In the conveyance of machinery and articles of a similar class, which are both heavy and delicate, it is of the utmost consequence that the load should not be disturbed between the beginning and the end of the journey. The traffic upon the line of railway between Birmingham and Bristol has been greatly restricted by the interruption of gauge at Gloucester.

"In respect to the conveyance of minerals, the inconvenience of a break of gauge would be very serious; the expense of the transfer would be sensibly felt; moreover, many descriptions of coal are subject to great deterioration by breakage.

"In regard to various articles of agricultural produce, the loss by removal would be less than on other classes of goods; much inconvenience, however, would be found in the transfer of timber; and the difficulty of shifting cattle, would be so great as to present an insurmountable obstacle to such an arrangement from the excited state of the animals after travelling by railway, and the

resistance they in consequence offer when it is attempted a second time to force them into a railway waggon."

4. *As applying to the Conveyance of Troops.*—"This is another use of railways which we have deemed it necessary to consider. Although a break of gauge on the line of route would produce both delay and confusion, yet, as it is usually practicable to give notice of the intended movements of a body of troops, the inconvenience of the break of gauge might be so reduced, as not to be an evil of great importance; but in the event of operations for defensive objects, against an enemy, the inconvenience would assume a serious character.

"It would appear, that, for the defence of the coast, the proper course would be to retain the great mass of troops in the interior of the country, to wait until the point selected by the enemy for his attack should be ascertained with certainty, and then to move upon that point such an overwhelming force as should be adequate to the emergency.

"The troops should be carried with their equipments complete in all their details, and with their artillery and ammunition; and it therefore appears indispensably necessary, in order to insure the requisite supply of carriages, where perhaps little or no notice can be previously given, that the whole should be conveyed in the same vehicles from the beginning to the end of the journey."

After considering the subject in several other points of view, which it would be needless to specify, the commissioners came to the conclusion that *a break of gauge would be a very serious evil.*

*Expedient of Telescopic Axles to apply to all gauges.*—Of the various mechanical contrivances submitted to the investigation of the commissioners, was one under the foregoing denomination; wherein the running wheels of the carriages are made capable of sliding along the axles when required, permitting the wheels to approach nearer to, or separate further from each other, and thus be applicable to both gauges. By detaching the wheels from one fixed point, then pushing the carriage along converging, or diverging rails, until the wheels were brought to fit the change of gauge, and screwing the wheels to the axles again at another fixed point, the required alteration would apparently be easily managed, but it is nevertheless liable to serious objections. It is well known that a very slight degree of unsteadiness of the wheels of a railway carriage upon the axles, renders it liable to run off the rails. The safety of an entire train might thus be endangered, by one case of neglect in refastening the wheels of a carriage; and when it is considered that the attendants would have to adjust a great many carriages in succession, sometimes as many as a hundred in one goods train; that the adjustments have also to be made hurriedly; occasionally in the worst of weather, and at night; besides the attention required for loading or unloading of goods; altogether, it would become so severe and anxious a duty to the attendants that it would be scarcely possible to avoid the occurrence of very serious accidents from oversight, neglect, or forgetfulness. But the danger attending the plan is not the only objection. On the ground of expense, the introduction of the plan is inadmissible.

*Expedient of mounting Carriages upon Trucks of a different gauge.*—The plan of running loaded waggons from a narrow gauge railway, on to trucks that work on the broad gauge lines, is of course one of facility; but it is only applicable for the transmission of goods from the narrow to the broad gauge. The attempt to carry loaded broad gauge waggons upon trucks on the narrow gauge rails, would be preposterous, as it would necessitate all the broad gauge lines to be provided not only with their large trucks, but a stock of narrow gauge waggons, or they would be unable to transfer the goods on to the narrow gauge rails, except occasionally. But even with regard to the passage from the narrow to the broad gauge, the system will not bear examination. "If the trucks are supported on springs, there is practically a difficulty in running the

waggon upon them; and if they are not supported on springs, they will sustain great injury on the journeys. If they are loaded singly, there will be a great delay; if they are placed in a row, and the narrow gauge carriages are run through the whole series, very great caution will be necessary to secure each carriage both in front and in rear." For the foregoing as well as other considerations, the commissioners reject the proposal as entirely inapplicable to the traffic of railways.

*Expedient of shifting the bodies of Carriages from one wheeled platform to another having a different gauge.*—Although the system has been partially adopted in France, of shifting the bodies of carriages from the road wheels to those of the railway, the commissioners regard it as inapplicable to our rapid travelling; while it deprives the railway system of one of its greatest conveniences, namely, "its readiness to receive almost any number of passengers without warning, and to carry them to any required distance."

*Expedient of carrying minerals and merchandise in loose boxes, capable of being shifted from one Truck to another,* in such manner that one may be carried on a narrow gauge, and two on a broad gauge truck.—The commissioners state that this plan has been repeatedly tried, and the experience is, that it has barely succeeded in a temporary trial by one engineer who had the entire control; but that it has in most instances failed, owing to the deterioration produced by the shifting of the mineral conveyed; though no expense was spared in the erection of proper machinery for effecting the transference of the loose boxes; and these failures occurred in a traffic which is comparatively regular, namely, that of coal. In traffic of a more varied character, the liability to failure would be much increased.

*Expedient for a Combination of two gauges on one line,* by placing one or two intermediate rails between those on the broad gauge, so as to enable the use of the engines and carriages of both gauges, would also be productive of many difficulties, and the expense be enormous. If two rails were placed between those of the broad gauge, so as to form a narrow gauge track, the carriages of each gauge might travel together, without any alteration of their buffers, as the distance of these from the centre is precisely the same in both. The cost of such an alteration has been estimated at even more than entire change of gauge, including engines, and carrying stock. The complication which it would introduce at the crossings would be attended with increased danger, or a loss of speed. It would also be difficult to pack and adjust such rails properly. In the case of a single rail being inserted at 4ft. 8½in. distance from one of those on the broad gauge, the difficulties just mentioned would be in a certain degree lessened, but it would introduce another, which seems to have escaped the attention of the commissioners; namely, that of causing the double traffic upon only one of the original broad gauge rails, and the single traffic on the other broad gauge rail. If we consider the enormous difference between the operating forces on the rails in a double train, the effect of the concussions of such an unbalanced force would be rapidly destructive of far more stable substructures than have hitherto been found necessary. It would at least render it necessary to make the single rail which sustains the double traffic much stiffer, and the supports more solid; otherwise a disruption would speedily ensue, and it would always be dangerous to travel upon. Besides, the narrow gauge traffic on the broad gauge line would probably continually increase, and thereby increase the disparity of the resisting powers of each rail, and never attain that uniformity of vibration and resistance, that appears to be essential to the stability of the structure.

The commissioners lay it down as the first principle, that intercommunication of railways throughout the country ought, if possible, to be secured. If, to obtain the last-mentioned object, it should be necessary to alter or make a change in any existing railways, they think that it may be left as a matter of

ulterior consideration for the legislature, whether in these limited instances the combination of gauges may not be allowed.

After giving to all the plans submitted to them, the most mature consideration, the commissioners came to the conclusion, that none of them were adapted to effect an adequate remedy for the inconveniences incident to a break of gauge; and hence they entered upon the following

*Considerations on the general policy of establishing an uniformity of gauge throughout the country.*—In the earlier period of railway history of this country, the great trunk-lines were so far separated as to be independent of each other, and, as it were, isolated in their respective districts, and no diversity of gauge was then likely to interfere with the personal convenience, or the commercial objects of the community; but now that railways are spreading in all directions, and becoming interlaced with each other in numerous places, that isolation is removed, that independence has ceased, and the time has arrived when, if steps cannot be taken to remove the existing evil of the diversity of gauge, a wider spread of this evil should be prevented. The commissioners having arrived at the decision that equalization is desirable, they proceed to consider what gauge would be the most eligible to adopt, under the following four heads:—

1. *Comparative Safety of the different Gauges.*—Experience has shown that railway accidents arise from collisions, obstructions on the road, points wrongly placed, slips in cuttings, subsidence of embankments, a defective state of the permanent way, loss of gauge, broken or loose chairs, fractures of wheels or axles, &c., and lastly from engines running off the lines from some other cause. Of these several causes of accidents, all except the last are obviously independent of the gauge; and with reference to the last, it does not appear that either of the gauges possesses more security than the other against such accidents. Only six accidents of the kind occurred between October 1840, and May 1845; whereas there have been no less than seven during the last seven months; and these last are all attributable to excessive speed, the majority having happened to express trains. Of these 13 accidents, 10 have occurred on the narrow gauge, and only three on the broad; but as there are 1901 miles on the narrow gauge, and only 274 on the broad, therefore the comparison per mile is in favour of the narrow. Nevertheless, as the speed on the Great Western much exceeded that on the narrow lines, some allowance is due on that score.

The primary causes of engines getting off the rails appear to be overdriving, a defective road, a bad joint, or a badly balanced engine. If, in consequence of heavy rains or other unfavourable circumstances, any part of the road becomes unsmooth, the engine sinks on one side as it passes along such part of the rail, suddenly rises again, and is thus thrown into a rocking and lateral oscillatory motion, with more or less of violence according to the rate of speed; and a very similar effect is produced in passing at high speed, from one curve to another of different curvature. A succession of strains is thus thrown upon the rails, and if, before the rocking subsides, the wheel meets with a defective chair or rail, which yields to the impulse, the engine and train are thrown off as a necessary consequence; but such casualties, as far as we can see, are equally liable to happen to both gauges.

Several differences in the construction of the broad and narrow gauge engines, with regard to their proportions and adjustments of the weight, have been supposed to operate as a cause of their running off the line. These points have been investigated by the commissioners; but they sum up their remarks on the score of safety by stating,—“Upon the whole, therefore, after the most careful consideration of this part of the subject, we feel bound to report, that as regards the safety of the passenger, no preference is due with well-proportioned engines to either gauge, except perhaps at very high velocities, where we think a preference would be due to the broad gauge.” The next question entertained was,

2. *The relative accommodation and convenience for Passengers and Goods on each Gauge.*—The first class carriages of the broad gauge are intended to carr

eight passengers in each compartment, and the compartments are sometimes divided by a partition and inside door. On the narrow gauge lines, the first class carriages are usually constructed to carry only six passengers in each compartment; and the same width is allowed for each passenger in both gauges. Until recently the broad gauge carriages were altogether more commodious than those on the narrow, but now the first class carriages on the narrow gauges possess equal commodiousness; they are both highly so.

In the second class carriages on the broad gauge, six persons sit side by side, each carriage being capable of holding 72 passengers. On the narrow gauge, generally, only four persons sit side by side, the total number in each carriage being 32. These last are the most comfortable of the two.

With respect to the ease of the carriage, or the smoothness of motion, the evidence taken is conflicting, but the experience of the commissioners led them to consider, that at the higher velocities, the motion is usually smoother on the broad gauge.

With respect to the conveyance of merchandise, such as manufactured goods and their raw materials; mineral products, such as coal, lime, iron and other ores; agricultural produce, such as corn, hops, wool, cattle and timber; the evidence of intelligent persons engaged in the carrying business has been taken, who expressed a strong opinion that the smaller is far the most convenient and economical. Another advantage of the smaller waggons is its economy in lessening the *dead weight*, where full loads cannot be obtained at the stations. Here the dead weight would be greatly increased on the broad gauge, unless the greater commercial evil were sustained of waiting until full loads were accumulated. For the foregoing reasons, the commissioners decide that the narrow gauge is the most convenient for the merchandise of the country.

3. *On the gauge best adapted for Speed.*—To ascertain this, the time tables of the several companies having fast or express trains were examined, and the returns furnished by those companies of the actual speeds attained by the express trains, during 30 successive days from the 15th June to the 15th July 1845. The commissioners also travelled in the express trains, and noted the speed, mile by mile; the results of which showed that the average speed of the Great Western, both by express and ordinary trains, exceeded the highest speed of similar trains on any of the narrow gauge lines. But some of the latter have trains which exceed the speed of those on the recently constructed lines on the broad gauge; owing to the comparatively unfavourable gradients and curves. These remarks apply to the Bristol and Gloucester, and the Swindon and Gloucester. The inclination and curves on the Great Western between London and Bristol are particularly favourable for high velocities. And it is worthy of remark that in some portions of the narrow gauge lines, where the gradients and curves are very easy, that the speed attained was for a time above that on the Great Western. The difference of effect, according to the nature of the gradients, is shown in a very strong light by a comparison of the time occupied in passing over different portions of the Great Western line. The speed from Paddington to Didcot by the express train is 47½ miles per hour; from Didcot to Swindon it is 41.1; from Swindon to Gloucester only 31.7; from Swindon to Bath 48.2; but returning only 37.2; from Bristol to Taunton, the speed is 46.3; and from Taunton to Exeter only 39.2.

It is stated that the locomotive engines on the Great Western line have not been altered from the opening of the railway, (which was designed on the broad gauge in order to obtain higher velocities with equal safety,) while the recently increased speed on the narrow gauge lines has been acquired by the introduction of new engines of greater power; and the commissioners seem to think that they are now as powerful as they can probably be made on the narrow gauge; but that the broad gauge lines have still the means of augmenting the power, and hence the velocity of their engines, within the limits of the stability of roads, to bear such increased weight and motion. Since the introduction of express trains, the accidents arising from running off the line have been indeed more numerous within the last seven months, than within the five preceding

years; and it is questionable whether this contest for speed ought to be carried to any greater length.

It is the opinion of several engineers, that it is the stability of the road, and not the power of the engine, that will prescribe the limits of safe speed.

"On the first introduction of passenger railways, speeds of about 12 miles per hour only were anticipated;" (which is difficult of comprehension, seeing that steam locomotives on the *common road* went faster,) the rails then employed weighed only 35lbs per yard, and the engines 6 or 7 tons. As soon as the speeds of 20 and 24 miles were attained, they found it expedient to increase the rails to 50lbs per yard, and the engines to 10 and 12 tons. Since that time the weights of the rails have been progressively increased from 65 to 85lbs per yard, and the ordinary engines on the broad gauge to 22 tons: while those on the narrow are only 2 or 3 tons less, and some few more; one even of 30 tons, on six wheels. This increased weight has been chiefly obtained by lengthening the boiler (augmenting thereby the evaporating surface), and fixing the engine cylinders on the outside. In such engines as have by this elongation been made to overhang the fore and hind axles considerably, the position of the outside cylinders have had, it is said, a tendency to produce an irregular or rocking motion; causing them to be less safe at high velocities. Mr. Stephenson admits the existence of this defect in some recent engines, but attributes it to merely the weight of the piston, which he proposed to counteract by an equipoise.

The commissioners are, however, of opinion, that this great length of engine is not essential to the attainment of high velocities on the narrow gauge lines. They timed the express trains on four different journeys on the South Western line, in both directions; that the whole distance was performed very satisfactorily in about 1 hour and 52 minutes, including the time of stoppages, being at an average of 41 miles per hour, on a line which, in one direction, rises for a length of more than 40 miles on a very prevailing gradient of 1 in 330; and in the other rises for several miles on a gradient of 1 in 250. On each occasion a distance of five miles, on a level part of the road, was passed at the rate of 53 miles per hour. The length of the engine boiler was only 8 ft. 7 inches, the driving wheels 6 ft. 6 inches in diameter; the leading wheels had both inside and outside bearings. The diameter of the cylinder in one case was 15 inches, in the others 14½ inches, both outside, and attached to the smoke box.

In proceeding to compare the locomotive engines, the commissioners remark that the boilers of the narrow gauge have a smaller power of evaporation than those on the broad gauge; and that whatever may be the attempts to augment that power, it is clear that they may, in this respect, be surpassed on the broad gauge. It is, however, a current opinion that the engines on both gauges have nearly obtained that speed and power which it would be justifiable to employ, in reference to the present strength of the rails and the firmness of the earthworks.

The diameter of the driving wheels of the broad gauge engines exceeds that of the driving wheels of the narrow gauge engines, which circumstance is unquestionably favourable to high speed; because the steam is used to greater advantage, and because the alternating shocks upon the machinery are less rapid. The commissioners think, however, that at the speed of 40 miles an hour, the difference between the two engines may be trifling, but that at speeds of 50 or 60 miles an hour, it may be worthy of notice. It becomes important then to inquire what may be the greatest desirable speed to be maintained on railways for ordinary purposes. The wishes of the public will be limited only by considerations of economy and safety. The greater the speed the greater will be the cost; and it is generally believed that it will be difficult to maintain the present express speed on the great trunk railways. The chief impediments are,—

1st. The difficulty of entirely protecting the fast trains from interfering with or coming into collision with the slow trains.

2d. The difficulty of seeing signals, especially in foggy weather, in time to enable the engine drivers to stop the fast trains.



4th. *The relative Economy of the different gauges.*—In the first construction of a railway, the narrower the gauge, the smaller will be the cost of the works. This applies to tunnels, bridges, viaducts, embankments, cuttings, sheds, workshops, turntables, transverse sleepers, and ballast, and the purchase of land; but it does not affect the rails, fences, drains, and station-houses. The exact difference, however, must depend in a great degree upon local circumstances.

As to the cost of the maintenance of way, that of the broad gauge must be rather the greater of the two.

The cost of the engines and carrying stock is generally more expensive on the broad than on the narrow gauge. But it is asserted by the advocates of the broad gauge, that as the engines will draw greater loads, the work can be done at a less charge per ton; and that a compensation is thus obtained for the increased outlay. How far this is practically the case is the next subject for inquiry.

The average weight of a passenger train on the Great Western railway (independent of the engine and tender, which weigh 33 tons) appears to be 67 tons; and the average number of passengers per train for the half-year ending the 30th of June, 1845, is only 47.2, whose weight, including their luggage, may be estimated at about 5 tons.

Mr. Gooch, the locomotive superintendent on the Great Western, estimates each carriage and its passengers on the broad gauge to weigh about  $9\frac{1}{2}$  tons, and therefore there would be seven carriages to make up the 67 tons above specified. The most commodious carriages on the narrow gauge lines, such as those on the South Western, weigh less than 5 tons; seven such carriages would therefore weigh about 34 tons, and being capable of containing 126 first-class passengers, weighing, with their luggage,  $12\frac{1}{2}$  tons, the total load would be only  $46\frac{1}{2}$  tons. Now we find, that even with a traffic as large as that of the London and Birmingham railway, the average per train would only be 84.9 passengers, weighing about 8 tons; so that, under the supposition of a traffic of this extent, the load of the seven narrow gauge carriages so occupied would only be 42 tons.

But Mr. Gooch estimates, from his own experiments, the relative powers of traction of the broad gauge engines, and of the narrow gauge engines, of the South Western railway, when working at the same speed, as 2,067 to 1,398, or as 67 per cent., and the load of the broad gauge in tons, to 45 tons, which would be the corresponding load for the narrow gauge; so that the narrow gauge engine has more power over the 42 tons it would have to draw, than the broad gauge has over its average load of 67 tons, both exclusive of the weight of the engine and tender; the narrow gauge carriages in this supposition being supposed to contain 84.9 passengers, and the broad gauge only 47.2.

It is obvious, from the foregoing statement, that the narrow gauge engine of the class we have been considering, has more power over the seven narrow gauge carriages, and a load of 126 passengers, than the broad gauge engine has over the seven broad gauge carriages, and the load of the same number of passengers; and that, therefore, if the Great Western had been a narrow instead of a broad gauge line, the South Western engines would have had the same command over the existing passenger traffic of the Great Western, as its own engines now have with the present construction of that railway.

The commissioners conclude their investigation of this question, by determining that the work would be performed at about the same expense for locomotive power.

Mr. Gooch has asserted that the Great Western company work their passenger trains at half the expense per ton, at which the London and Birmingham company work their passenger trains. The fact is, however, that Mr. Gooch's calculations refer to the *gross*, and not to the net loads; and, therefore, the comparison is not applicable, so far as regards the profits of these companies, and affords no proof of economy in working the passenger traffic on the Great Western system.

In the case of "goods traffic," the circumstances are not the same; railway conveyance for merchandise seems only to be required a few times in each

day, and the trains are generally large. The "through" waggons have for the most part a full load, and the disproportion between the gross and nett weight is consequently much less than in the passenger trains; still, however, it frequently happens on the London and Birmingham railway, that waggons are forwarded to a considerable distance to "road side stations" containing not more than a ton of goods; which must happen on any long line of railway. The same occurs also in waggons coming in from branches along the trunk line, and in all such cases, the heavy large waggon of the broad gauge must be disadvantageous; but although the evil is not so great with goods waggons of the broad gauge as with their passenger carriages; still the loss by dead weight is greater with these than by the smaller waggons, and we do not perceive any advantage in the broad gauge to counterbalance it; for where speed is not an object, we believe that engines of nearly the same tractive power are to be found on many narrow gauge lines, as those in use on the broad gauge.

Thus far the question has been considered with reference to the railways as they now exist, and composed in a great measure of trunk lines of considerable traffic; but the railways to be made in future will in some degree be branches, or lines, in districts having less traffic than is to be provided for in the existing railways; and hence, if for the greater trunk lines a superiority were due to the broad gauge system, that superiority would be less for lines yet to be constructed, of a smaller amount of traffic; and necessarily, if the preference were given to the narrow gauge for the existing lines, that system would be still more entitled to the preference for the railways of smaller traffic to which we look forward.

Towards the close of this inquiry Mr. Brunel requested, on the part of the broad gauge companies, to institute a set of experiments to test the power of their engines; and Mr. Bidder, on the part of the narrow gauge companies, undertook, in consequence of such application, to make corresponding experiments on the narrow gauge. After sanctioning these trials, and being present at the performance of them, we may observe, without entering into a minute detail of the results, that they proved the broad gauge engines to possess greater capabilities for speed, with equal loads, and generally speaking, of propelling greater loads with equal speed: and moreover that the working of such engines is economical where very high speeds are required; or where the loads to be conveyed are such as to require the full power of the engine. \* \* \*

"After a full consideration of all the circumstances that have come before us, and of the deductions we have made from the evidence, we are led to conclude—

"1st. That as regards the *safety*, accommodation, and convenience of the passengers, *no decided preference is due to either gauge*, but that on the broad gauge the motion is generally more easy at high velocities.

"2d. That in respect of *speed*, we consider *the advantages are with the broad gauge*, but we think the public safety would be endangered in employing the greater capabilities of the broad gauge much beyond their present use, except on roads more consolidated and more substantially and perfectly formed than those of the existing lines.

"3d. That in the commercial case of the *transport of goods*, we believe the *narrow gauge* to possess the greater convenience, and to be more suited to the *general traffic of the country*.

"4th. That the *broad gauge involves the greater outlay*, and that we have not been able to discover either in the maintenance of way, in the cost of locomotive power, or in the other annual expenses, any adequate reduction to compensate for the additional first cost."

The commissioners, esteeming the importance of the highest speed for express trains as being of far less moment than affording increased convenience to the general traffic of the country, consider that the narrow gauge should be preferred for general convenience; and if uniformity should be required they recommend that uniformity to be produced by an alteration of the broad to the narrow gauge; especially as the extent of the former is at present only 274 miles, while that of the latter is 1901 miles; and as the alteration of the former to the latter, even if of equal length, would be the less costly as well as the less difficult operation.

They wish, however, not to be understood to express an opinion that the gauge of 4ft. 8½in. is in all respects the best suited for the general purposes of the country. Some engineers have recommended 5 feet as the best dimension; others have suggested 5ft. 3in., 5ft. 6in., and even 6ft., but none so much as 7 feet, except those who are interested in the broad gauge lines. Again, some eminent engineers contend that a 4ft. 8½ gauge gives ample space for all the railway requirements, and recommend no change to be made in the gauge. The Eastern Counties railway was originally constructed on a gauge of 5 feet, and has since been converted into a gauge of 4ft. 8½in. to avoid a break of gauge; and it has been stated that some lines in Scotland, originally on the gauge of 5ft. 3in. are about to be altered to 4ft. 8½in. for the same reason. \* \* \*

Under the present state of things, we see no sufficient reason to recommend the adoption of any gauge intermediate between the narrow gauge of 4ft. 8½ and the broad gauge of 7 feet; and we are particularly struck by the circumstance, that almost all the continental railways have been formed upon the 4ft. 8½ gauge, the greater number having been undertaken after a long experience of both the broad and the narrow in this country; nor must the fact be lost sight of, that some of these railways have been planned and constructed by English engineers, and amongst that number we find Mr. Brunel, the original projector of the broad gauge. Mr. Brunel was also the engineer of the Merthyr Fydoil and Cardiff line, which is on the 4ft. 8½ gauge; and we think that the motives which led to his adoption of the narrow gauge in that instance would equally apply to many English lines.

We are sensible of the importance, in ordinary circumstances, of leaving commercial enterprise, as well as the genius of scientific men, unfettered; we therefore feel that the restriction of the gauge is a measure that should not be lightly entertained; and we are willing to admit, were it not for the great evil that must inevitably be experienced when lines of unequal gauges come into contact, that varying gradients, curves, and traffic, might justify some difference in the breadth of gauge. This appears to be the view which Mr. Brunel originally took of the subject; for the Great Western proper is a line of unusually good gradients, on which a larger passenger traffic was anticipated; and as it touched but slightly on any mineral district, it embraced all the conveniences and advantages of the broad gauge system, and was comparatively free from the influence of those defects on which we have commented; but such a breadth of gauge, however applicable it may have been considered to its particular district, appears ill suited to the requirements of many of our northern and midland lines.

In reference to the branches already in connexion with the Great Western railway, we may observe, that the greatest average train on the Oxford branch for two weeks in July and October was only 48 tons; on the Cheltenham branch it did not exceed 46; between Bristol and Exeter 53; and between Swindon and Bristol it was under 60 tons. With such a limited traffic the power of the broad gauge engine seems beyond the requirements of those districts.

From an estimate furnished to us, and the general grounds of which we see no reason to dispute, we find that the expense of altering the existing broad gauge to narrow gauge lines, including the alteration or substitution of locomotives, and carrying stock, would not much exceed £1,000,000; yet we neither feel that we can recommend the legislature to sanction such an expense from the public monies, nor do we think that the companies to which the broad gauge railways belong can be called upon to incur such an expense themselves (having made all their works with the authority of Parliament), nor even the more limited expense of laying down intermediate rails for narrow gauge traffic. Still less can we propose, for any advantage that has been suggested, the alteration of the whole of the railways of Great Britain, with their carrying stock and engines, to some intermediate gauge. The outlay in this case would be vastly more considerable than the sum above mentioned; and the evil, inconvenience, and danger to the traveller, and the interruption to the whole traffic of the country for a considerable period, and almost at one and the same time, would be such, that this change cannot be seriously entertained. Guided

by the foregoing considerations; the commissioners submit the following recommendations to the legislature:—

1st. *That the gauge of 4ft. 8½in. be declared by the Legislature to be the gauge to be used in all public railways now under construction, or hereafter to be constructed, in Great Britain.*

2d. *That unless by the consent of the Legislature, it should not be permitted to the directors of any railway company to alter the gauge of such railway.*

3d. *That in order to complete the general chain of narrow gauge communication from the north of England to the southern coast, any suitable measure should be promoted to form a narrow gauge link from Oxford to Reading and thence to Basingstoke, or by any shorter route connecting the proposed Rugby and Oxford line with the South Western railway.*

4th. *That as any junction to be formed with a broad gauge line would involve a break of gauge, provided our first recommendation be adopted, great commercial convenience would be obtained by reducing the gauge of the present broad gauge lines, to the narrow gauge of 4ft. 8½in. and we therefore think it desirable that some equitable means should be found of producing such entire uniformity of gauge, or of adopting such other course as would admit of the narrow gauge carriages passing, without interruption or danger, along the broad gauge lines.*

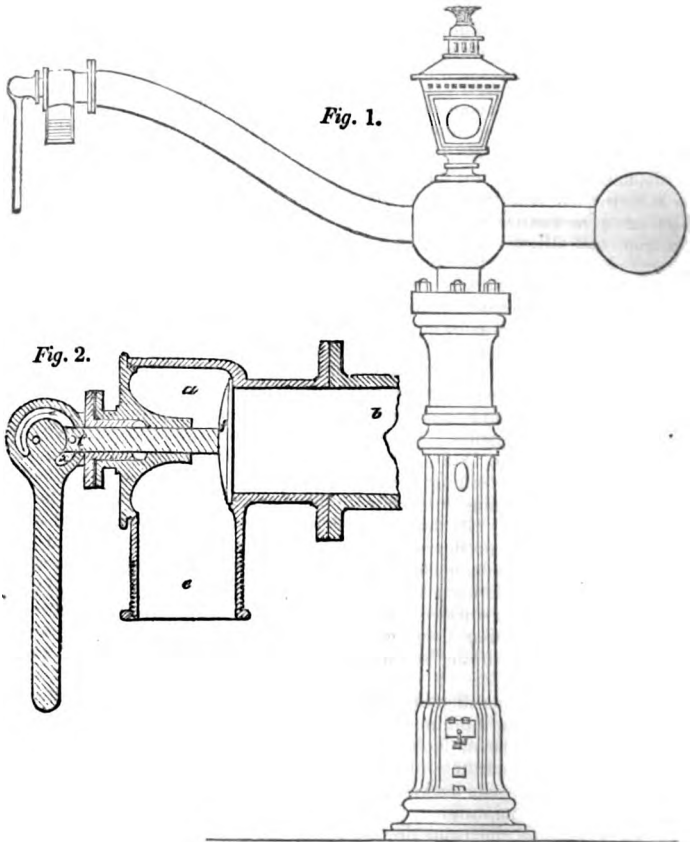
*Cleansing Rails.*—To avoid the impediment that is likely to occur occasionally from snow or ice upon railways, Mr. Grime, of Bury, has proposed, under a patent right, dated the 21st February, 1831, to dissolve the same by making the rails hollow, and causing hot water, steam, or hot air, to pass through them, so as to keep them at a temperature above the freezing point. For this purpose boilers are to be erected by the side of the railroad, at distances of two or three miles from each other. One of these boilers being supplied with water, and heat applied, the water is forced, by the pressure of steam on its surface, through a pipe communicating with the hollow rail, and reaching nearly to the bottom of the boiler, and along the railway, till it ceases to give out a sufficient quantity of heat to melt the snow or ice which may lodge on the rails, when the water is received into another boiler by means of a feeding vessel placed over it. This feeding vessel is connected with the boiler by two pipes,—the one descending from its bottom to very nearly the bottom of the boiler, to form a water communication, and the other from its top to the top of the boiler, to form a steam communication. Each of these communications is provided with a stop-cock and levers, both of which, as well as one from a cock on the pipe which supplies the feeding vessel, are connected with a float in the boiler, by means of a wire passing through a stuffing-box, in a manner similar to that in Eng. Ency. Vol. I. p. 216, where the float descends by the escape of water through the exit pipe into the rails: the steam and water communication from the feeding vessel to the boiler are thereby opened, while the supply pipe to the feeding vessel is closed, when the water contained therein is forced, by the pressure of steam on its surface, into the boiler, till the float is elevated so as to close the communication between the feeding vessel and the boiler, and to open that between it and the hollow rails, for the admission of a fresh supply of cooled water.

It is stated in the specification, that instead of the hollow rails, hot water pipes may be laid along the line of road, in contact with rails of the usual construction. The lengths of hollow rail are connected together by pieces of copper pipes fitting accurately into the ends of the pieces of hollow rails, which they unite, leaving a space between them sufficient to allow of their expansion by the increased temperature.

For the purpose of cleansing the rails from snow, grease, or sand, while the engine is travelling thereon, Mr. Melling applies small jet pipes, which hang immediately over the centre of each rail, and through these pipes, by means of a swivel cock, connected with the boiler, either steam, or hot water and steam, may be at any time blown, so as to make the rails perfectly clear and dry, which (in snowy or frosty weather, or at the station ends of the rails, where they are always greasy) will be found to prevent the slipping effect of the wheels;

especially when used in combination with the patentee's improved mode of coupling, described at page 452.

*Water Crane.*—The mechanism for supplying the tenders of locomotive engines with water, necessarily differs according to its situation, the position of the source whence the water is derived, and other circumstances; but the arrangement usually consists of a cistern elevated about 10 or 12 feet above the railway, from which the water flows into what is termed a water crane, the head or neck of which turns on a pivot, and permits the water to be directly discharged by the opening of a valve or cock, into the reservoir of the tender. In the following cut, *Fig. 1*, is given an elevation of a water crane, with an improved valve applied thereto by Mr. Underhay, and for which he has taken out a patent. The external form of this portion of the water crane is shown at *k*; but in order that it may be better explained and understood we have shown this new "Cam-valve cock" (as the inventor terms it) in section, on a larger scale by *Fig. 2*. At *a* is the valve-box; *b* the inlet pipe; *c* the outlet pipe;

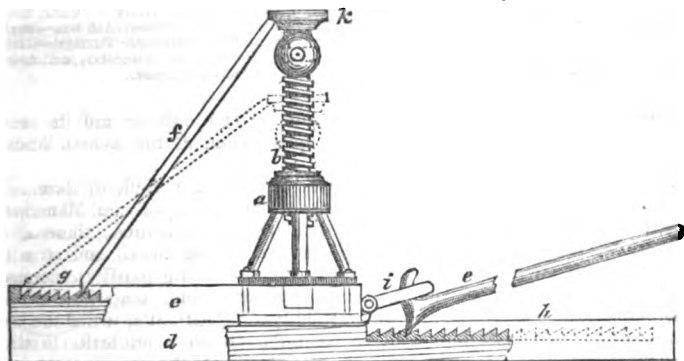


*f* the valve, *g* the spindle which works through the stuffing box shown; *h* is the handle to the cam, which is cut away on both sides and through to the extent shown, and an arched piece *e* is left standing out from the centre (when viewed endwise), with an open space between it and the body of the cam. The valve spindle has a cleft made in the upper end of it, the two cheeks of which carry

a cross pin *l*. The arched piece *s* of the cam is inserted in this cleft behind the cross pin *l*, so that when the cam handle is brought down into the position shown, the cam acts upon the spindle and closes the valve with an intensity of force, insuring the contact of the opposite surfaces by merely the weight of the lever handle. To open the valve, it is of course only requisite to lift the handle. The simplicity of construction of this valve apparatus, and the ease and certainty of its operation, render it a very desirable appendage to railway water cranes.

*Curtis's Traversing Jack.*—The accompanying figures represent Curtis's "Traversing screw jack" for replacing an engine or carriages upon the rail.

The screw jack *a* is bolted to the plank *c*; at the other end of the plank is fixed the rack *g*, in which the toe of the strut advances as the screw *b* is elevated; the strut works in a joint in the follower *k*; the position of the strut when the screw is depressed is shown by the dotted lines. The object of this strut is to



relieve the screw of the violent cross strain, to which the apparatus is subject when the engine or carriage is pulled over by the lever, which strain is entirely transferred to the strut, and the screw has merely to carry the load.

The operation of traversing the jack is as follows:—by hooking the link *i* upon the hook of the lever *e*, the toe of the lever being inserted into a ratch of the rack *s* of the lower plank, a man, bearing down the end of the lever, drags the apparatus and engine or carriage towards him with great facility: the same lever is used to turn the screw and to produce the traverse motion. By this apparatus an engine of 16 tons weight has been replaced upon the rails in five minutes by the engineer and stoker alone; thus those delays which are the subject of so much annoyance and loss to railway proprietors and the public need not happen in future. The apparatus is exceedingly portable and cheap, and no train ought to be allowed to go out without its being sent along with it: it may be carried either upon the tender, or upon some other place which may be selected for it.

COST OF RAILWAYS PER MILE.

The London & Blackwall . . . .	£287,693	The Midland Counties . . . . .	35,402
London & Greenwich . . . . .	267,270	Edinburgh & Glasgow . . . . .	35,024
London & Croydon . . . . .	80,400	Birmingham & Gloucester . . . .	29,000
Dublin & Kingstown . . . . .	59,122	London & South Western . . . . .	28,004
London & Brighton . . . . .	56,981	North Union & Bolton & Preston	27,799
Great Western . . . . .	56,372	Grand Junction . . . . .	22,293
London & Birmingham . . . . .	52,882	York & North Midland . . . . .	23,066
Liverpool & Manchester . . . . .	50,923	Glasgow, Kilmarnock & Ayr . . . .	20,407
Manchester & Leeds . . . . .	47,824	Dublin & Drogheda . . . . .	15,652
Glasgow & Greenock . . . . .	35,451	Dundee & Arbroath . . . . .	8,570

## SECTION III.

### LOCOMOTIVE ENGINES AND CARRIAGES.

Increased efficiency of modern Locomotives.—Similarity in the general features of construction.—Stephenson's Patent Engines.—Melling's Patent Engines with new Couplings, and Breaks, and Slidevalves.—Tayleure and Co.'s six wheeled Engines.—On the comparative advantages of four and six wheeled Engines.—Bury and Co's defence of four wheeled Engines, with a "Practical Engineer's" reply thereto.—Remarks thereon.—Experiments on the Grand Junction, and London and Birmingham lines.—Wyndes and Ericsson's improvement for ascending Inclined Planes.—Kollman's Locomotive Guides.—Prosser's Guide Wheels.—Stephenson's compound Axles.—Loah's Patent Wheels.—Lipscomb's Patent Wheels for preventing Vibration and Noise.—Dirck's Wooden Felled Wheels.—Mode of fixing Tubes in Boilers.—Water Gauge.—Water Ash-box.—Bergin's Buffers.—Mallet's Buffers.—Terminus Buffer.—Curtis's safety Passenger Carriage.—Curtis's improved Truck for the conveyance of Carriages.—Booth's Railway Connectors, and mode of checking Speed.—Hick's Locomotive Engine.—Booth's Patent Axle Grease.

HAVING explained the various arrangements of the railway and its accessories, we now proceed to describe the construction of the several kinds of vehicles which run thereon.

Since the first introduction of railways for passenger traffic by locomotive engines, that is to say, since the opening of the Liverpool and Manchester line, the efficiency of the engines has been greatly augmented; those of the present day transporting much heavier loads at a greater speed, and at a less cost, than the engines of 15 years back. This is owing partly to increased dimensions of the boilers, and the steam cylinders, and somewhat to that splendid accuracy of workmanship and solidity of construction which the keen rivalry of the manufacturing engineers has induced them to put forth: to which may be added many improvements in the details of the machinery; some tending to simplify and reduce friction, others to create new effects and so increase efficiency. Nevertheless, in the principal combinations, and the general features of the whole structure, there is a certain similarity, which while it attests their relationship, distinctly shows the intellectual training to which they have been submitted by the mechanists of the present day.

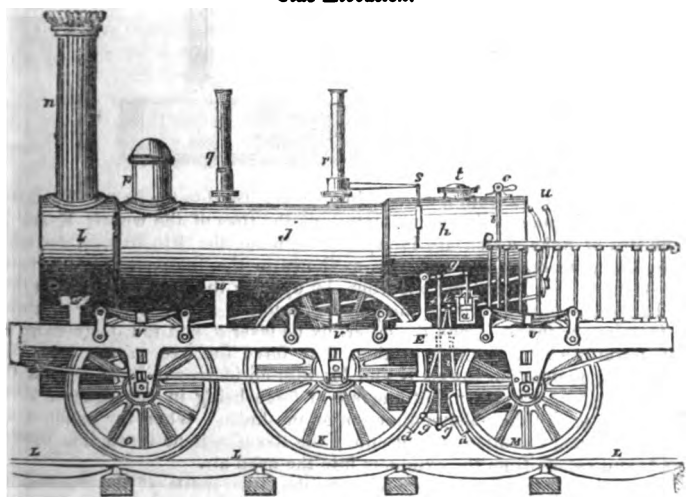
The boiler is almost universally composed of a vertical compartment (square or cylindrical in its horizontal section), containing within it the furnace, (now designated the "fire-box,") surrounded by water; this vertical compartment opens into a horizontal cylindrical chamber, containing the greater portion of the water, which is heated by the gases and flames proceeding from the fire, through an extensive series of small tubes of thin metal, lying horizontally in parallel straight lines throughout; one end of every tube being open to the fire, to receive the heated current, and the other end opening into a vertical "smoke box," at the other extremity of the horizontal cylindrical chamber. Into this smoke box is discharged all the smoke and gaseous products of the combustion, which escape in a rapid current, excited by a blast produced by the escape of the education steam into a small chimney, erected immediately over it. The requisite supply of fuel for the journey, and of water for evaporation, is carried by a judiciously contrived machine called a tender, which is linked close to the engine.

The principal diversities in the construction are to be found in the number and position of the wheels; in the description of the framing, which sometimes extends outside the wheels, and sometimes lies within them; and in the position of the steam cylinders, and the mode of connecting them with the shaft of the driving wheels. In some engines the steam cylinders are placed in the smoke box, and the connecting rods transmit the force to two cranks, forged at right angles to each other, near the middle of the axle of the driving wheels; whilst in other engines the steam cylinders are placed outside the frame, the driving shafts are straight, and the connecting rods are attached to cranks fixed

on each end of the shaft, or to pins in the bosses of the wheels. In the early part of the working of the Manchester and Liverpool railway, the locomotive engines were generally constructed with a double cranked axis upon the two main wheels of the carriage; which wheels were provided with flanges on their peripheries to keep the engines on the rails. But this mode of construction was considered by Mr. Stephenson to be defective, owing to the liability of the crank axis becoming strained or broken by the excessive friction of the flanges against the rails, especially in making deviations from the straight course. Any lateral bending of the cranked axle, although short of a fracture, will, it is evident, by putting the wheels out of square, produce a violent surging motion of the engine, and render a fracture of the axle, or the running of the engine off the rails, extremely probable. To provide a remedy for such serious liabilities, Mr. R. Stephenson, under his patent of 1833, divested the tires of the main impelled wheels of their flanges, and in lieu thereof, employed two small additional wheels with flanges behind the former. These additional wheels were applied beneath the fire-place end of the boiler, for keeping the engine straight on the rails in its progress forward; and the axles of these wheels being straight, and consequently stronger than the cranked, are not liable to be broken or bent, as experience has proved with respect to the axes of the fore wheels, which remained unaltered.

The engines made by Mr. Stephenson to carry out these improvements we shall now proceed to describe with reference to the annexed cuts, designed to illustrate the same. At K K are main impelled wheels on the cranked axes, without any projecting flanges on the tires, which run on the edge rails L. M M are the additional small wheels with flanges, applied beneath the furnace end of the boiler; and O are the ordinary small wheels with flanges beneath the chimney end of the boiler, where the working steam cylinders are situated. The small wheels O and M with flanges, keep the engine straight upon the rails, and the large impelled wheels K have only to advance the engine, and to bear a due proportion of the weight. By this arrangement, therefore, the

*Side Elevation.*



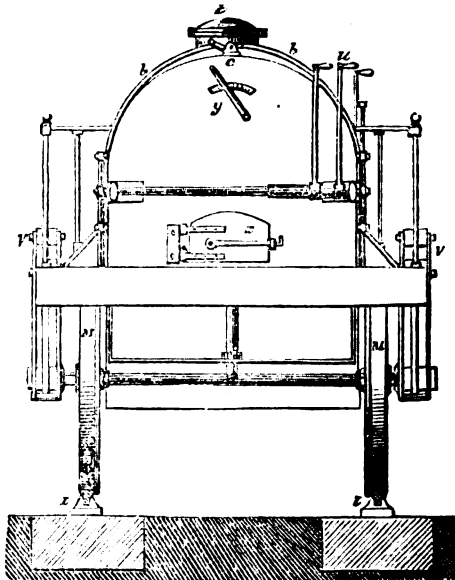
cranked axle is liberated from all lateral strain, which is wholly transferred to the small wheels with flanges, which, having straight axles, are capable of sustaining it.

It is often of essential importance to be able to arrest the progress of a carriage on a railway with great promptitude; and the breaks in ordinary use



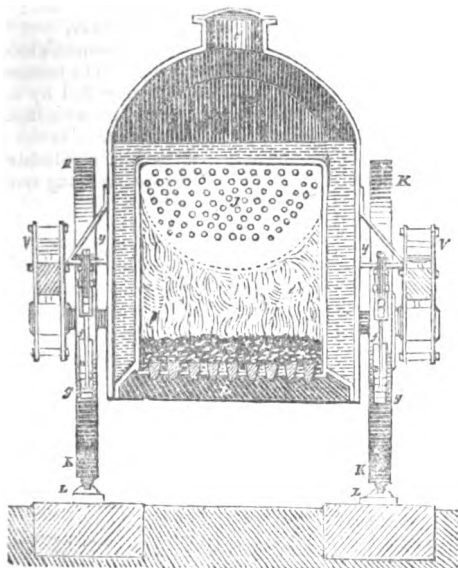
for this purpose have not always been found sufficiently potent. As a remedy for this inconvenience, Mr. Robert Stephenson, under the same patent, proposes to employ the force of steam acting upon pistons or plungers in small cylinders; so that when it is required to stop the train it is only necessary to turn a small cock, which allows the steam to flow instantaneously through a pipe into the cylinder, and by its pressure on the piston give motion to a system of levers, which cause two breaks or clogs to be forced against the peripheries with great energy, and to arrest the motion of the vehicles very quickly. These clogs or breaks, and their mode of action, are shown in the side elevation on the preceding page. *a* is the hollow cylinder into which a plunger is fitted, to act by a lever *y*, and an upright rod *f*, upon the two breaks *d d*, which are suspended

*End Elevation.*

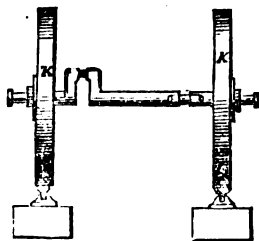


by pendulous links *x* from a centre pin or bolt *e*, fixed to the frame. The breaks are caused to apply to the circumference of the tires of the wheels *K* and *M*, by means of links, which are interposed between the two breaks, and which links, when put down into an angle, as shown in the figure, leave the breaks free of the wheels *K* and *M*; but when, by opening the cock *c*, the steam from the boiler is admitted through the pipe *b b*, into the hollow cylinder *a*, it raises up the plunger therein; and the latter, by its lever *y*, and rod *f*, draws up the links towards a straight line, and then they force the two breaks apart from each other, against the wheels *K* and *M*, with an increased force beyond that which the plunger exerts; that increase of force being in consequence of the leverage at *y*, and the oblique direction of the links. When the handle of the cock *c* is turned the other way, it allows the steam to issue through an upright spout, and escape from the cylinders into the open air.

The following letters have reference to the other parts of the engine. . At *h* is the fire-box; *i* the ash-grate; *j* is the boiler, cylindrical in shape through the lower part of the transverse sectional area of which are passed longitudinally a great number of small brass tubes, proceeding from the furnace chamber, which serve as the hot-air flues, and conduct the same into the smoke-box *l*, at the other end, whence the gases resulting from the combustion of the fuel ascend the chimney *n*; *p* is the steam-head; *q* a safety-valve;

*Transverse Section.*

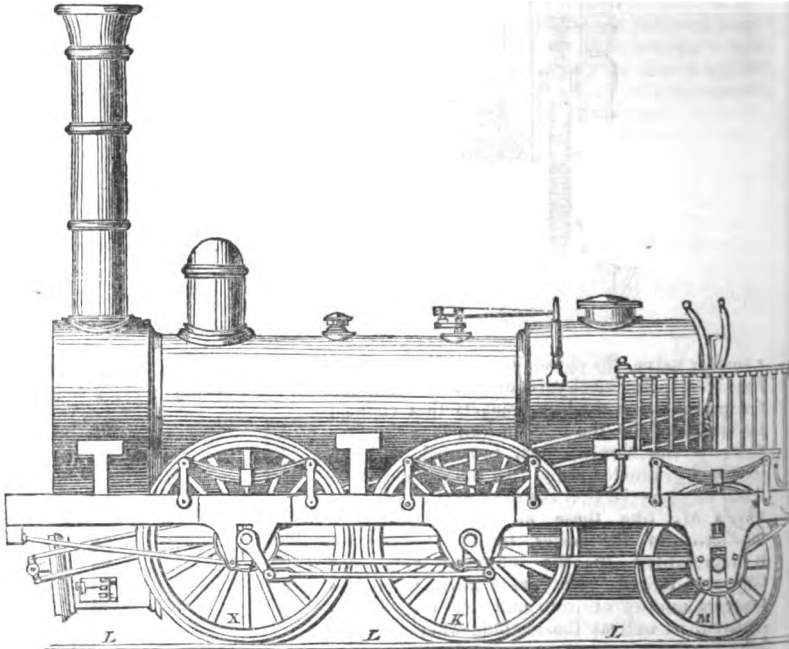
*r* another valve, the extremity of the lever of which is held down by the elastic force of a spring steel-yard at *s*; *t* is a man hole; *u* the working gear; *v v v* the springs; *w w* the iron brackets that connect the machinery to the wooden frame; *x* the fire-door; *y* the throttle-cock, provided with a lever and graduated scale. In the end elevation it will be observed that the axes of the running wheels *M*, like those at *O*, are straight; the form of the axles to the wheels *K*, is represented in the annexed cut, and they are forged with great care from the toughest quality of iron, and are turned and centered, as well as the running wheels, in the lathe.



Locomotive engines, constructed according to the description of the foregoing, Mr. Stephenson says, have the effect of preventing the boilers being burnt out so soon as usual, by allowing them to be made of greater magnitude and strength; the additional wheels supporting the extra weight. The bearing springs are used for the extra small wheels, the same as is now done for other wheels in ordinary engines; the six springs used causing all the six wheels to apply and bear fairly on the rails, and ease all jolts and concussions; the relative weights, or portions of the whole weight of the engine, which is to be borne by each of the six wheels, being regulated by the strength and setting of their respective bearing springs. The main wheels, which are impelled by the power of the engine, are, in all cases, left loaded with as much of the weight of the engine as will cause sufficient adhesion of those wheels to the rails, to avoid slipping thereon. The larger the entire capacity of a boiler is, the more metallic heating surface it will contain; and, consequently, render unnecessary that intensity of heat which is so prejudicial to the metal. And the jet of education steam which is thrown into the chimney to produce a rapid draught therein, may be greatly diminished in its velocity, which will permit the education steam

to escape from the working cylinders with greater freedom than could be permitted with smaller boilers, wherein a greater heat and a more rapid generation of steam are indispensable to furnish the requisite power.

The annexed cut exhibits another form of Mr. Stephenson's locomotive engine, but with the foregoing improvement added thereto. The foremost wheels, at the chimney end of the boiler, are, in this, however, impelled by means of outside cranks and connecting rods, as well as the two middle wheels K, which are on the cranked axle; in other respects, the improvement is the same as in the other engine. The breaks, or clogs, are, of course, applicable to this or any other engine, but they are left out in this instance, as being unnecessary to our illustration.

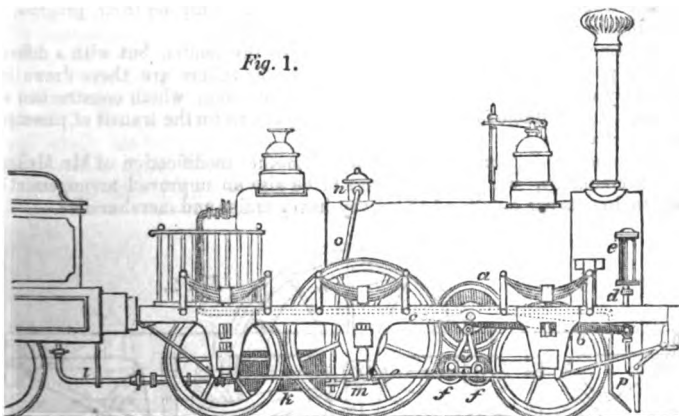


*Melling's Patent Couplings and Breaks.*—To obviate the inconvenience and waste of power by the slipping of the wheels of locomotives on railways, when they are in a wet or greasy state, Mr. John Melling, of Liverpool (the manager of the locomotive department of the Manchester and Liverpool railway,) has devoted much of his attention. In the specification of his patent granted in July, 1837, and reported in *Newton's Journal* for January, 1841, (whence we derive the following account,) he observes:—

“ My improved method of coupling the engine wheels is effected by the application of a pair of friction wheels or rollers, of any suitable diameter, placed between the peripheries of the driving wheels, and the running wheels of the locomotive carriage. This assistance is, however, only required in those instances where the weight upon all the wheels is not uniform, or sufficient to prevent some of them slipping upon the rails; the quantity or degree of friction being readily accommodated to circumstances, and the connexion or coupling between any two wheels, whatever their respective diameters may be, produced or removed at pleasure. This contrivance is very advantageous in comparison with the ordinary previous mode of coupling, because, if the rails be dry or

the adhesion be sufficient, the anti-friction wheel couplings may be lifted off and remain unused, while the ordinary system of outside cranks and connecting rods must always continue working, and thus, at certain times, only act as an incumbrance. Another important feature in this improved mode of coupling the wheels, is the smoothness with which the engine works when the cranks are passing their centres, instead of being subjected to the sudden blows and jerks which occur to engines coupled in the ordinary manner. This improvement is effected by transmitting a considerable portion of the weight from the cranked or driving axle to the straight or independent axle, which entirely prevents the tremulous lateral motion of ordinary locomotive engines; passing over inequalities in the surface of the road; and tending greatly to prevent the destruction of the engine springs, and the beating of the rails, usually attendant upon such occurrences.

In the subjoined engravings *Fig. 1* represents a side elevation of a locomotive engine, in which the before-mentioned improvements are introduced, and some others which we shall describe afterwards. To avoid confusion, many of the ordinary details of a locomotive engine are left out as unnecessary to our present object.



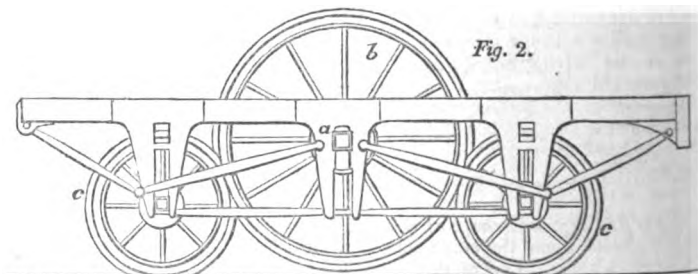
At *a* is the improved coupling wheel, in its proper position for connecting the driving wheels upon the crank shaft, with the running wheels upon the fore axle of the engine. One of these coupling wheels or rollers is placed on each side of the engine, and bearing upon the periphery of the driving and running wheels; they are suspended in wrought iron levers *b*, the fulcrum of which are at the end *c*, and the other ends of these levers are attached to piston rods *d*, which work in small steam cylinders *e* *e*, which have a steam cock in common, to admit the steam from the boiler. Now it will be seen that when it is necessary to couple the engine wheels, in order to obtain more adhesion upon the rails and prevent the slipping of the engine, the cock is to be opened, which by letting steam into the tops of the cylinders causes their pistons to descend and depress the levers, which forces the coupling wheel *a* into contact with the peripheries of the driving and running wheels of the engine, as long as the steam is allowed to remain in the cylinder. When the coupling wheel is no longer required to act upon the engine carriage wheels, it may be dispensed with, by turning the steam in at the bottom of the small cylinders, which raises the pistons and levers, and consequently lifts the coupling rollers from off the peripheries of the driving and running wheels. These coupling wheels are formed with a groove in their peripheries, wherein the flanges upon the tire of the carriage wheels run, and serves to keep them effectually in gear, and at the same time prevent the distance between the wheels ever becoming too narrow

for the width of the rails, in the event of the wheels loosening upon their axes, which occurrence has frequently thrown the engine off the line of railway. Thus it will be seen, that the wheels of the engine may be coupled and uncoupled at any rate of speed they may be running, and without difficulty or interruption, without any restriction as to dimensions in the driving, running, or coupling wheels. (It is also deserving of remark that this coupling wheel is not confined in its application to locomotive engines, but may be applied as a medium for driving all kinds of machinery, in order to dispense with any jerking or unevenness of motion occasioned by toothed gearing, or in order to obviate the difficulty frequently arising from the teeth of wheels breaking).

In connexion with the before-mentioned apparatus and illustrated by the same figure is an improved drag or break. At *ff* are two small anti-friction rollers, suspended from the levers *b*, their own peripheries being in contact, but hanging in guides *h h*, entirely free from the peripheries of the engine carriage wheels; and when it is necessary to stop the engine, it may be done with great rapidity and ease by letting the steam into the bottom of the cylinder *e*, thus raising the lever *b* (at the same time releasing the coupling wheel *a*), and bringing the peripheries of the two rollers *ff* into close contact with the tires of the engine carriage wheels, and thus effectually to lock them or impede their progress, by immediately reversing the direction of the revolution.

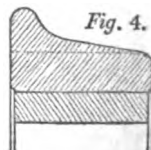
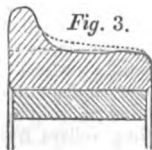
The same system of apparatus is applied to the tender, but with a different mode of putting the same into operation, as the rollers are there drawn into contact by a vertical screwed rod and suspended links; which construction will be found most suitable for tenders and carriages used for the transit of passengers and merchandize.

The annexed diagram is explanatory of another modification of Mr. Melling's friction couplings, which he considers to be also an improved arrangement for such engines as are employed to convey heavy trains and merchandize.



At *a* is the main cranked or driving axle, in the centre of the engine; upon the ends of this axis, two large driving wheels *b* are fixed, so as to run just clear of the rails; but so as to bear forcibly upon the fore and hind wheels *c c*, and thus transmit the power of the engine through them, and obtain a perfect adhesion upon the rails at all points.

With a view of showing in a strong light the great practical advantages



attending the patent coupling wheels, Mr. Melling exhibits two diagrams in his specification representing the wear upon the tire of a wheel by the use of his coupling, and without it, which we shall herewith add.

Fig. 3 represents the amount of wear upon the true cone of the tire of wheels of engines that have run without being coupled, and therefore entirely the effect of slipping against the rails. Fig. 4 shows a wheel which has performed the same number of journeys as the other, but which has been coupled according to the patentee's method. In the latter, owing to the entire prevention of slipping, there is no perceptible wear.

Another improvement effected by Mr. Melling, and described in the London Journal for January 1841, consists in a combination of apparatus for working the slide-valves of locomotive steam engines, which he states "entirely dispenses with the imperfect mode of working them by eccentrics," as hitherto practised. The great reduction of friction effected by it is equivalent to a corresponding increase of power. "A farther improvement, arising from this mode of working the slide-valves, is, that they are driven from the ordinary connecting rod instead of being worked by eccentrics mounted on the crank shaft, as heretofore; in which case, if by any accident the crank shaft happened to have become bent or broken, it could not effect the opening and closing of the side valves.

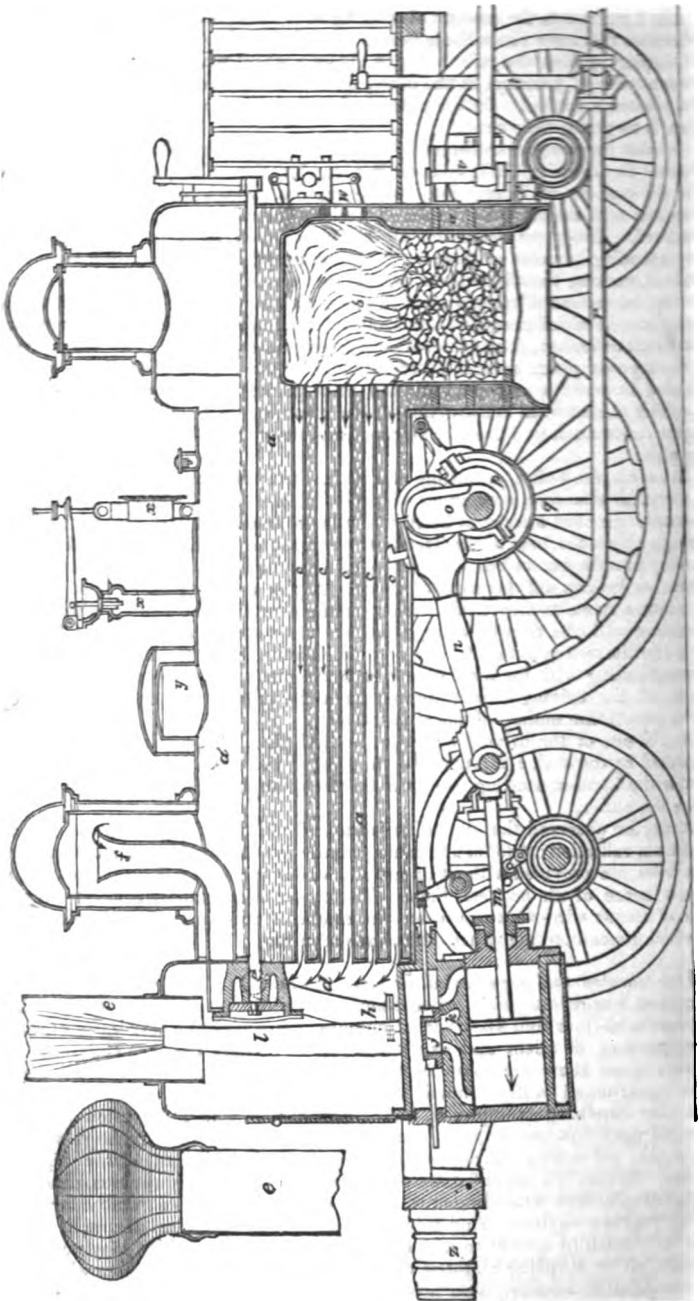
Having now given several external views of the more modern form of six-wheeled locomotive engines, and their principal accessories, we shall proceed to exhibit the *internal* construction of the parts, by an enlarged section of an engine constructed by Messrs. Tayleure and Company, and shown on the following page.

At *a a a* is the boiler, consisting of a horizontal cylindrical chamber connected to a vertical chamber, containing within it the fire box *b*, which is surrounded by water. *c c c* are a series of horizontal tubes of small diameter, serving as flues through which the heat is imparted to the horizontal portion of the boiler, and opening into the smoke box *d*, which is surmounted by the funnel or chimney *e*, shown as broken off for want of space. At *f* is a bell-mouthed pipe (rising up within a dome to prevent the water passing over with the steam), which communicates with the throttle valve *g*, whence the steam is conducted by branch pipes *h* to the two cylinders *i*. At *j* is the slide valve, *k* the eduction aperture communicating with the blast pipe *l*: *m* is the piston rod, *n* the connecting rod, *o* one of the driving cranks formed upon the axle, *p* one of the eccentrics which govern the motion of the slide-valves.

At *q* is one of the driving wheels, *r* the feed pipe, the supply of water being regulated by the cock *s* through the medium of the key *t*; *v* is the connecting link, *w* the hand or starting gear, *x x* the steel-yard safety valve, *y* the man hole, and *z* the buffer.

It may be observed that the boiler is encased with wood to prevent the loss of heat from radiation; and for the same purpose the steam chests, or domes and man holes, are provided with a thin metallic casing (generally of brass) leaving a narrow space of air between them. The top of the chimney is covered by a cage of coarse wire-work to prevent the escape of red-hot cinders, for the want of which precaution many accidents have occurred.

*Four-wheeled and six-wheeled Railway Locomotive Engines.*—A difference of opinion has of late years existed amongst Railway engineers as to the relative merits of four and six-wheeled engines. Amongst the advocates of each there are men of talent and experience; and amongst the locomotives made on each plan there are many of a highly efficient character; and all seem to be constructed with so much solid beauty of workmanship, as to render them very imposing examples of mechanical skill. The fabrication of these splendid machines can only be conducted with due economy in large works, where the self-acting machinery is elaborate, powerful, and of the highest quality. Hence the manufacture of railway locomotive engines is confined to comparatively few establishments, amongst whom there is a rivalry for producing the best engines. And when any accident occurs to an engine, it is too often attributed by a rival to a defect in its construction, which may not have contributed to it in the slightest degree. To arrive at a correct knowledge of the comparative economy and mechanical advantages between the engines of



rival companies, any ordinary inquirer would meet with insuperable difficulties; because, the advocates and parties he must consult on either side are generally interested in the result. The only means of attaining *certain* information, would be by the appointment of a parliamentary commission of able and independent men, similar to that which recently so admirably investigated, and decided the question of the rival gauges; which commission would have the power of calling for *all* the evidence that could be obtained, and of proving experimentally the facts elicited. If we are to believe the statements of the rival parties who have figured in this paper controversy, it is not merely a question of science, or of public convenience that has to be determined, but one wherein life is placed in serious jeopardy; one party going so far as to charge the other with the sacrifice of "*more than a hundred lives,*" by persisting in their supposed erroneous system of construction!

The chief manufacturers as well as champions of the four-wheeled locomotive engine, are Messrs. Bury, Curtis, and Kennedy, of the Clarence Foundry, Liverpool, who make them for the London and Birmingham railway, where they have been continually and exclusively used, we believe ever since its first opening. "To show the process of reasoning by which, aided by experience and the closest observation, they have arrived at the conclusion of preferring the four-wheeled to the six-wheeled engines," they sent forth a Circular in vindication, accompanied with engravings of the "Albert." To this measure they were induced, they state, because "there have not been wanting those whose anxiety to feed the public prejudice, and to profit by the effect of it, has led them to allege many things against four-wheeled engines, which are both untenable in principle, and untrue in fact," and because "in all the discussions which have taken place on the subject, none, or scarcely any stress, has been laid on that which is substantially the main feature of the whole case; namely, the different effects of inside and outside bearings." This Circular has been answered in the pages of the *Mechanics' Magazine* by a rival party, under the anonymous signature of "A Practical Engineer," who, we are assured by the Editor of that excellent Periodical, is a gentleman of as high authority on railway matters, as Messrs. Bury, Curtis, and Kennedy.

We shall now proceed to give the Circular of Messrs. Bury & Co., and place in juxtaposition the answer to it by a "Practical Engineer," to save needless repetition and space, and for the convenience of our readers.

To render the arguments of Messrs. Bury, Curtis, and Kennedy in favour of their four-wheeled locomotives more readily intelligible, we shall first lay before the reader the drawings and description of the "Albert" four-wheeled locomotive, combining their recent improvements.

#### *Messrs. Bury, Curtis, and Kennedy's Circular.*

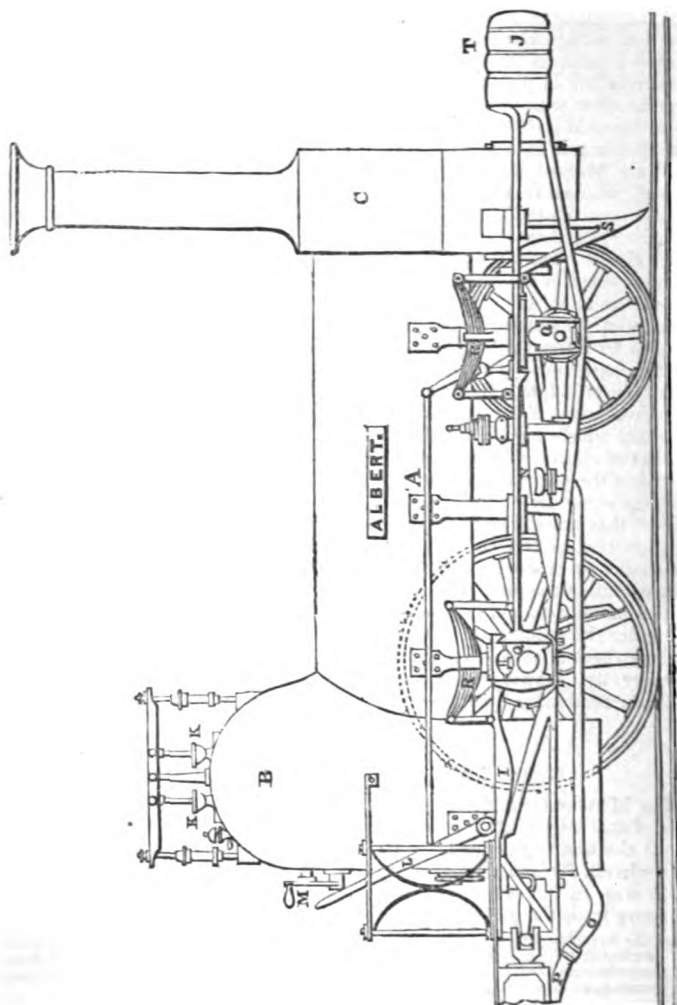
1. The Manchester and Liverpool railway was the first that ventured upon the use of steam locomotive power, for the conveyance of passengers at a rapid rate, and the first engine made for that great and spirited undertaking, in 1828, had six wheels. This engine, however, failed to give satisfaction, and a premium of £500 was, in the same year, offered by the Directors for the best engine. After many trials the premium was awarded to a four-wheeled engine.

On the foregoing paragraph 1, the "Practical Engineer" states, that the engine supposed to be alluded to (The Twin Sisters) was not accepted by the Company, "because it would not generate steam enough for the speed required, and *not* because it had six wheels, or *outside* framing, as the framing was not of that kind."

2. The four-wheeled engines of that day had all of them outside frames, and were used on the Liverpool and Manchester railroad for four or five years, without other objections than the loss from the breakage of axles, arising from the defective plan of the frame, viz., in its being placed outside the wheels.

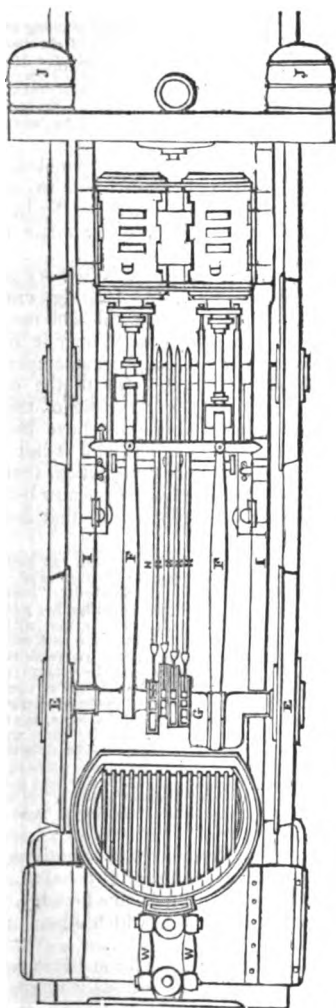
In reply to paragraph 2, the "Practical Engineer" says, "The following engines were the first employed on the Liverpool and Manchester railway after its opening: and all of them had *inside* framings; crank pins in the leading wheels; with four wheels each; namely, the Rock et, Meteor, Arrow, Comet, Dart, North Star, Northumbrian, and Majestic."





SIDE ELEVATION OF MESSRS. BURY, CURTIS AND KENNEDY'S FOUR-WHEELED LOCOMOTIVE ENGINE.

## PLAN OF MESSRS. BURY, CURTIS, AND KENNEDY'S FOUR-WHEELED LOCOMOTIVE ENGINE.



A, is the boiler; B, fire-box; C, smoke-box, in which are placed the cylinders; D, D, the cylinders (valve-box, and valves removed); E, E, driving wheels; F, F, connecting rods; G, G, crank axles; H, H, H, H, eccentrics for working valves; I, I, framing of engine; J, J, buffers; K, K, safety valves; L, L, starting and reversing handle; M, M, steam cock for regulating speed; N, N, brass pumps for supplying boiler with water; O, O, pipes for conducting water from tender to pump; P, P, leather hose between engine and tender; Q, Q, bushes for axles; R, R, springs; S, S, guards for clearing rails; W, W, links connecting the engine to tender.

3. Experiments were subsequently made, intended to show that economy of fuel resulted from the use of a large fire-box; but the consequence was, that this part of the engine became so heavy as to require support behind it, and hence arose the re-introduction of a third pair of wheels, which had been previously abandoned as highly objectionable.

"Owing to the frequent occurrence of accidents with, and the pitching and sidious motion of the four-wheeled engines, it was resolved to try the effect of six wheels, by putting an additional pair under two of the Company's old engines, namely, the Atlas, and the Mar." "The result of the experiment gave so much satisfaction, that I believe all the Company's engines which were thought to be worth the expense, were made into six wheelers; and the engines which are now (1843) making for that line, are six wheelers. It is altogether erroneous, therefore, to say that the third pair of wheels was introduced on account of the use of large fire boxes."

4. The engine makers, generally, of the country had no choice of the form of engine, but had to conform to the plans of the directors or engineer of the Company, and did not examine minutely the merits of the new plan of construction, and engines continued, for some years, to be made ordinarily with outside frame, large fire-box, and six wheels.

5. It was the good fortune of the conductors of this foundry to originate the construction of four-wheeled engines, with inside framing, crank axles, and cylinders, placed in the smoke-box, all the practical and mechanical objections to the six-wheeled engines, and particularly with outside framing, having been foreseen at the earliest period. The first engine made upon this principle was manufactured in this foundry, in 1829, prior to the opening of the Liverpool and Manchester railway. As the principle of the four-wheeled engine thus made gained publicity, great alterations have been introduced, from time to time, in ordinary six-wheeled engines, and at last we find, which we may be pardoned for adverting to with some satisfaction, that in the latest invention of an eminent engineer, the outside framing is now being abandoned, or at least, that the inside framing has been adopted in that instance, and the large fire-box dispensed with.

In reply to paragraph 5, the "Practical Engineer" says, "I am not prepared to say that Messrs. Bury and Co. were not the first who constructed engines of 'four wheels, with inside framing, crank axle, and cylinders placed in the smoke-box,' considered as a combination of parts; but taking this statement in connexion with other parts of the circular, it is calculated to produce a very false impression, and I have met with several persons who have been misled by it." "Every person at all acquainted with railways, must know that outside framing is of comparatively recent date, long subsequent to Messrs. Bury and Co. becoming engine makers. The reference made in the latter part of this paragraph to the use of inside framing, by an 'eminent engineer,' is one of the boldest things I ever saw. It can hardly be possible that persons engaged in the construction of locomotive engines so long and so extensively as Messrs. Bury and Co. have, can be ignorant of the fact, that Mr. G. Stephenson made engines with inside framing more than 30 years ago. Even if they did not know that fact, can any body conceive it possible that they should so soon forget that the Rocket, and many other engines subsequently made by Mr. R. Stephenson for the Liverpool and Manchester Railway Company, had inside, and not outside framing? You will observe that it is not stated that that 'eminent engineer' is now adopting the inside framing for the first time, but that the outside framing is now being abandoned. The object of the authors of this paragraph is obvious enough."

6. The frequent variations in the construction of locomotives serve to prove that the designers of six-wheeled engines, with outside framing, are convinced that their plan was not a perfect one: whilst, in this foundry, the same plan has been continued with which we began, and to which others are now coming round.

7. This being, in brief, the history of passenger locomotives up to the present time, we think it due to ourselves to give the reasons why we have so perseveringly adhered to our plan of engine with four wheels only, and inside frames, and we cannot do better than give the following compiled extract from a paper published in the transactions of the Society of Civil Engineers, and read before the society, March 17, 1840. It contains the statement of our opinions, of the soundness of which we had then had ample experience, and which still remain not only unchanged, but strengthened.

8. Next to a good boiler, which governs the economy of fuel, the most important point in the construction of a locomotive engine (inasmuch as it most materially influences the cost of repairs) is to connect all the parts firmly together by a strong and well arranged framing, so that they shall

retain their relative position when the engine is in motion, and that it shall receive and bear the strain, and the concussions to which every part is subject. The inside framing possesses a great superiority in this respect over the outside framing, as it forms a stronger and more direct connexion between the cylinder, the crank axle, and all the moving parts; and it bears all the strain of the engine, without throwing any portion of it on the boiler, as is the case with the outside framing.

9. These advantages are best described by comparing it with the ordinary outside framing submitted to the principal strains which it has to resist.

10. The most important is that caused by the whole power of the engine acting as a direct strain upon the crank as it passes over either centre.

11. With the inside framing the centre line of the connecting rod is only 10 inches distant from the centre line of the frame, and the total distance between the bearings is  $43\frac{1}{2}$  inches; but where the framing is outside the wheels, these dimensions are necessarily 20 inches, and 72 inches respectively; and the effects of the strain on the crank, in this case, would be, to its effect with the inside framing, as 14 is to 8.

"We have the *very remarkable* discovery announced, (says the Commentator,) that the nearer the points of support are to each other, the steadier the superstructure; and Messrs. Bury and Co. prefer a base of  $43\frac{1}{2}$  inches, to one of 72 inches! The statement of the 'effects of the strain on the crank' is erroneous, as all six-wheeled engines are, I believe, provided with inside framing to resist the strain of the cylinders."

12. For this reason, when the principal frame is placed outside the wheels, it becomes necessary to have an additional inside framing, to prevent the fracture of the axle. These additional inside frames not only cause an increase of friction on the bearings of the cranked axle, but also throw a considerable strain on the boiler, which then becomes the medium of connexion between the inside and outside frames, the inside frames being fixed at one end to the bottom of the smoke-box, and at the other end to the fire-box, while the principal frame is attached, by long brackets, to the body of the boiler.

"This paragraph (12) is strictly in keeping with the whole of the circular. The framing, both outside and inside of the wheels, in the four and six wheeled engine, is attached to the smoke-box and the fire-box, and also generally to the boiler. Messrs. Bury and Co.'s framing is, in my opinion, very defective in point of durability; and as a mechanical arrangement, inferior to any thing of the kind made by those persons who are convinced that their plan was not perfect."

13. The fact, that the use of four additional inside frames occasions six bearings on the axle, (that axle being only 6 feet long,) renders the system of principal outside framings so objectionable, that that circumstance alone should suffice to cause their rejection, for it is well known to practical men, that it is impossible to key so many bearings perfectly true, and to maintain them so when the engine is working; and even if this provision were attained, the aggregate friction on the four inside, and the two outside bearings, would be much greater than when it is all thrown upon two bearings; because, in the first place, all the friction due to the weight of the boiler is borne by the two outside bearings alone, and that which results from the pressure of the steam, through the medium of the connecting rod, is thrown upon the four inside bearings; the pressure on the outside bearings is vertical, and the mean pressure on the inside bearings is nearly horizontal. So that, if, instead of acting separately, these two amounts of pressure were thrown on the same bearings, the friction would only be due to the resultant of the pressures, and would, consequently be much reduced.

This (13) is denounced as a very "uncandid paragraph, if not something worse." "Messrs. Bury and Co. must be aware that not more than one or two frames at the most have been put into engines made within the last six years. I do not understand what can be meant by 'it is well known to practical men, that it is impossible to key so many bearings, &c.' It is not usual to key bearings. Whatever may have been intended, this paragraph is not likely to deceive any one in the smallest degree acquainted with the subject."

14. Another important feature is the strain to which locomotive engines are liable, from the pressing or striking of the flanges of the wheels against the rails, when travelling on a curve.

15. In engines with the bearings inside the wheels, the weight of the boiler has a tendency to bend the axle down in the centre, while the pressure of the

flange against the rail acts upon it in a contrary direction, and thus one strain counteracts the effect of the other. If the bearing is outside the wheel, the weight of the boiler tends to bend the axle upwards, and a strain on the flange of the wheel acting in the same direction and in addition to it, when the breakage of an axle takes place, these joint actions tend to force the wheels under the engine, and there being no flange on the outside of the wheel to prevent it, the engine is thrown off the rails, which, it is evident, cannot happen with an engine having inside framing, because the weight of the bearings presses the flange of the wheel against the rail, and assists the length of the journal in keeping it from falling or being thrown off the rails.\*

"The introductory part of this paragraph (15) is not disputed; but Messrs. Bury & Co., in adopting inside framing, did no more than copy Mr. Blenkinsop, Mr. Stephenson, and many others. As to the concluding part, Messrs. Bury & Co. may consult the Prussian Journals of May last" (1842) "and the evidence given at a late inquest on the London and Birmingham Railway."

16. Several instances have occurred on the London and Birmingham railway, when an axle has broken, that not only have the wheels remained on the rails, but the driver has been able to proceed with the train to the nearest station.

"This admission is more than might have been expected, seeing that Messrs. Bury and Co.'s engines are perfect."

17. The stiffness of the single inside framing is not only a remedy against the excessive wear and tear which are consequent on a less perfect union between the parts of the engine, but its simplicity allows the whole machinery to be arranged in a more compact form, and constructed with greater solidity, with this additional advantage, that the engine driver, while standing on the foot-plate, can inspect the whole of the machine, and detect any derangement requiring his attention.

18. It is evident that the round form of fire-box possesses great advantages over the square fire-box: first, it is much safer than the square fire-box, being made nearly in that shape which an excess of pressure beyond its stiffness would tend to bring it to, if made in any other form; moreover, the safety of the boiler with a square fire-box is nearly dependent on the strength, individually, of each of the stays which is fixed in it, (of which there are a great number,) whereas the pressure in the round fire-box is borne equally by the whole area of the plates of which it is composed: again, the corners in the square fire-box, in which the combustion is always languid, and consequently injurious, are avoided in the round fire-box.

19. A lead plug is placed at the culminant point of the round fire-box, and will therefore melt before any other part is left dry, and, as the top row of tubes is placed two or three inches below the culminant point, it is almost certain that the extinction of the fire will prevent the tubes being burnt; but, in a fire-box with a flat top, the melting of the lead would only occur when the whole surface was dry, and probably injured.

20. It is admitted that a locomotive engine should be as light as is consistent with great strength, simple in its construction, composed of as few parts as possible, and that the greatest regard should be had to the diminution of friction; it is thence obvious that four wheels must be preferable to six, provided they carry the engine with the same steadiness.

"The proviso at the end of this paragraph is a very important one, but it is not secured in the four-wheeled engine; for if that has less friction than the six-wheeled engine, why do the engines on the London and Birmingham railway consume more coke per carriage per mile than those on the Liverpool and Manchester railway? Eighteen months or two years ago, the difference was rather more than two to one, and is still very considerable."

21. The use of six wheels originated, (as we have before shown,) in the necessity of supporting the large and heavy fire-box, which was not sufficiently balanced by the smoke-box end; but no such necessity can exist in the locomotives made according to the accompanying plan, as the weight is nearly equally distributed on the front and hind wheels, and not only would two additional wheels be useless, but they would be prejudicial and dangerous when the engines are travelling upon curves.

\* N. B. These effects are subsequently explained by the aid of diagrams.—Ed.

" This paragraph (21) commences with a misstatement, which has been already noticed. The London and Brighton Railway Company can speak to the latter part, as a man from Messrs. Bury & Co.'s has been two or three months putting a third pair of wheels (which were sent from Liverpool,) to each of the five or six engines made by the firm for that line; one of which engines, previous to the additional pair of wheels being put under it, caused a great loss of life not long ago."

22. A four-wheeled engine travelling upon a curve is driven, by the direct application of the moving power, towards the outside of the curve; but, as the wheels are rather conical, the large diameter of the cone will ride on the outside rail, while the smaller diameter of the opposite wheel will bear on the inside rail, and this difference, (as the outside rail is longer than the inside one,) will allow the wheels to revolve without slipping or grinding.

" Another notable discovery in mechanics! Hitherto it has been always understood, that for the conical form of the wheels to produce the effect here described the axles must be radii."

23. With an engine upon six wheels, if the two leading wheels assumed this position, the others would necessarily be dragged after them; but a still more important point is, that the angle which the centre line of the locomotive forms with the tangent of the curve in which it is caused to move, is much greater with six wheels than with four, so that the flange of the wheel presses more against the rail with the former than with the latter engine.

24. The pressure against the outside rail, arising from this cause, will be in direct proportion to the distance between the front and hind axle of either engine, so that it will be as 10 to 6.

" 'Mechanicus' in the Railway Times, has shown the reverse to be the case. That the lateral motion of the four-wheeled engine will bend the rails, was shown by the accidents on the Eastern Counties, and the Paris and Versailles Left Bank railways, where the rails were bent in a straight part of the line. I believe no instance has been known of a six-wheeled engine bending rails."

25. This pressure and consequent friction is still further increased by the action of the middle wheel, which tends to ride on the same curve as the front and hind wheels, but is prevented from doing so by being in a straight line between the two, and is thus forced to move laterally between the chord and the circumference of the curve.

26. The friction arising from this lateral motion further presses the engine against the outside rail. Thus the four-wheeled locomotive has, in proportion, a greater weight on the front wheels, it presses less against the outside rail, and offers much less friction when travelling on curves; hence, it has less tendency to be thrown off the rails, it is more simple in its construction, less expensive in repairs, on account of this simplicity, and the smaller cost of it fully justifies the directors of the several railways who have given the preference to this description of engine.

" It is notoriously untrue that the four-wheeled engine has less tendency to be thrown off the rails than the six-wheeled engine, as the Liverpool and Manchester, the London and Brighton, the Paris and Versailles Left Bank, and especially the Eastern Counties Railway Companies can well attest. Messrs. Bury and Co.'s engines are by no means as simple as the modern six-wheeled engines, and cannot be kept in order at so small a cost. With reference to the original cost, if the statement of an Eastern Counties' director, in a letter published in the Railway Times about eighteen months back, may be depended upon, Messrs. Bury and Co.'s charge for a four-wheeled engine with an iron fire-box (for I understand they will make no other) was 50% more than Messrs. Sharpe, Roberts, & Co. then charged for a six-wheeled engine of the same size with a copper fire-box. The North Midland Railway Company can give some information concerning iron fire-boxes, as they have had to put copper ones in lieu of the iron ones made by Messrs. Bury & Co."

27. At the time the above paper was read before the Society, the four-wheeled engine had but few supporters, arising, no doubt, from the erroneous supposition, that the safety of the engine was in proportion to the number of wheels used.

28. It has, however, been steadily gaining ground in public estimation, and from the alterations going on in the construction of the six-wheeled engine, the advocates of them are evidently less confident in their superiority; and it is most gratifying to us that the advantages to be gained by the use of inside framing, which we then pointed out, are now tacitly admitted by our opponents of the greatest practical experience, who are gradually abandoning the outside frame.

"Messrs. Bury and Co. acknowledge that the four-wheeled engine had but few supporters in March 1840, but they say that since that time, it has been steadily *gaining ground*: they should have said, *losing ground*. The public, including nearly all the engineers of the day, many of whom are clear-sighted men on other subjects, are unable to see the merits of four-wheeled engines. The way in which Messrs. Bury and Co. here speak of inside framing, would lead persons unacquainted with the subject to believe that the outside framing is falling into disuse, but this is by no means the case."

29. As the inside frame becomes more and more general, the third pair of wheels will disappear, as not only useless, but really tending very materially to produce those accidents which they are supposed to guard against.

30. Indisputable proof has been furnished, that an engine with *inside framing* cannot come down by the breakage of an axle; an engine, therefore, is equally safe on that plan of construction whether on four, six, or eight wheels.

"Since the circular was published, three instances at least have occurred, of four-wheeled engines having come down after the breaking of the front axle, by which accidents, taken collectively, it is believed more than one hundred lives have been sacrificed."

31. The advantages of four-wheeled engines, on our plan of construction, we maintain to be the following: 1st. The engine on four wheels is less costly than the one on six wheels; therefore to have the same number of engines, or the same power, on a line of railway, much less outlay of capital is required.

"The four-wheeled engine ought to be less costly than the six-wheeled engine, but hitherto, I believe, that has not been the case. An additional number of inferior engines, of equal nominal power, will be required to compensate for the smaller power of each arising from that inferiority, as may be seen on the London and Birmingham and Grand Junction railways. The London and Birmingham Railway Company employ two engines to draw such trains as are drawn at full as high a speed by one engine on the Grand Junction railway, although, on the latter line, the engines are what are now called small."

32. 2d. It allows the engine to be got into less space, consequently it is more compact, firmer, less likely to derangement, and much lighter.

"The four-wheeled engine is, on the contrary, generally six inches, and often nine inches longer than the six-wheeled engine."

33. 3d. Though the engine is lighter, the adhesion is more perfect, from the weight on the driving wheels remaining nearly uniform, however unequal or out of level the rails may be; but in the engine with six wheels the adhesion is often imperfect (arising from the impossibility of mathematical precision in maintaining rails on the level,) although there may be fully as much weight on the driving wheels generally; that is, the fore and hind wheels sometimes carry the greatest part of the engine. When the driving wheels get into an uneven part of the road, and the constant action of the power of the engine is not resisted by the adhesion at these points, the driving wheels revolve without properly advancing the train, as every observant traveller knows; and all weight carried beyond what is necessary for adhesion on the rails, is an unprofitable load. There is much less of this in the four-wheeled than the six-wheeled engine, seeing that there is only one pair of wheels used for adhesion both in the four and six-wheeled engine, when used for passenger traffic; but, as the four-wheeled engine is lighter than the six-wheeled engine, there is less power required to take it up the inclines, and therefore more available power left applicable to the traction of the train.

"The assumed superiority of four-wheeled engines would be more readily believed by railway proprietors, if Messrs. Bury and Co. would convince them that a greater amount of traffic can be done with the same number of four-wheeled engines and weight of fuel than can be done with six-wheeled engines."

34. 4th. The engine is safer, as it adapts itself better to the rails, not being so likely to run off the line at curves or crossings.

"As curves or crossings, but what at the straight parts? The greater liability of four wheeled engines to run off the line in straight parts, is a fact incontrovertibly established by the experience of the Eastern Counties, the London and Brighton, and the Paris and Versailles railways."

35. 5th. It is more economical in the working, requiring less fuel, there being also a less amount of depreciation, as there are fewer parts in motion, consequently, less friction, or wear and tear, and fewer parts to maintain; and even those are more easily got at, therefore much less expense is incurred in those repairs which are common to both plans.

"Every point in this paragraph is just the reverse of the truth."

36. 6th. The buildings, turn-tables, lathes, drills, smithies, and other costly conveniences necessary for the maintenance and repair of the engines, are not required on so large and extensive scale, as the engine on four wheels is less in size than the one on six wheels.

"The whole of this is at variance with facts, except so much as refers to the size of the turn-tables."

37. 7th. As the engine is more simple in its form and parts, there are fewer chances of delays, stoppages, and disappointments during the journeys, or the times of taking the trains.

"Whatever the 'chances' may be, what are the facts? Not only have the greatest number of accidents happened with four-wheeled engines, but those accidents have been among the most disastrous that have occurred."

38. Whilst, therefore, those individuals who have advocated the use of the six-wheeled engines are constantly changing their ideas, at one time adopting a large fire-box with the outside frame, and the addition of a third pair of wheels behind the heavy box to carry it, then changing to the small fire-box, with the third pair of wheels placed before it, and, subsequently, by the tardy adoption of the inside frame; we have been steadily persevering with our original plan, of engines on four wheels, which is now brought to a state of perfection for power and economy far beyond anything we could have expected. In proof of this, we can confidently refer to the London and Birmingham, the Eastern Counties, the Midland Counties, the North Union, the Lancaster and Preston, and the Manchester, Bolton and Bury railways, which are worked exclusively with the form of engine we have adhered to; and also to the Edinburgh and Glasgow, Glasgow and Ayr, and Runcorn Gap and St. Helen's, and several other lines which have in part adopted it.

39. In justice to ourselves we have thought it right to lay these remarks before the public, at the same time that we are quite ready to construct engines upon six, or any other number of wheels, freeing ourselves from the responsibility of the consequence of any other plan than our own; and only requesting that such of our friends and the public as may entrust their orders to us will permit us at least, for the safety of travellers, and our own credit, to adhere to inside framing.

BURY, CURTIS, AND KENNEDY.

"It appears from this, that the four-wheeled engine 'has been steadily gaining ground, until Messrs. Bury and Co. have discovered that it would be more profitable to make six-wheeled engines than—to close their works.'" February 2, 1843.

We were unwilling to interrupt the continuity of the foregoing controversy by any remarks of our own, as they would perhaps have caused some confusion as to their authorship; but we will now briefly observe, that some parts of the replies of the "Practical Engineer" are somewhat irrelevant to the subject, and of no public interest; which would have been avoided, had Messrs. Bury and Co. expressed themselves with more discrimination as to the origin of the particular arrangements of construction they alluded to. For our own parts, we never for a moment supposed that those gentlemen meant to lay a claim of invention to *four-wheeled* engines, or to *inside* framing;—because it must have been notorious to the most superficial observers, that those modes of construction were more extensively adopted than any other, in the early locomotive engines. But we regarded the observations in their circular, which gave rise to the animadversions of the "Practical Engineer," merely as a defence of those arrangements which long practical experience in manufacturing for the most successful line of railway in the kingdom (where they have been undeviatingly used,) had led them to consider the best: and which circumstance, we may add, has earned for them a high reputation as practical engineers.

We shall here annex Messrs. Bury and Co.'s diagrams, explanatory of the effects of inside and outside framings in the case of a broken axle, alluded to in the preceding circular at page 462.



Fig. 1.

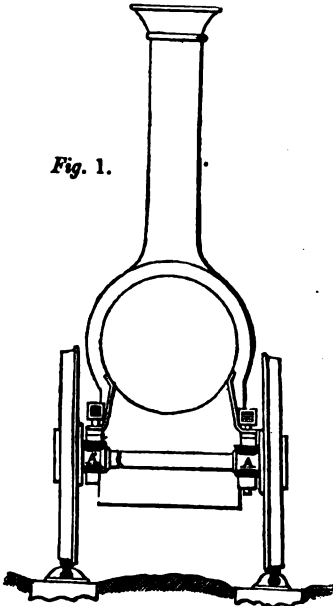


Fig. 2.

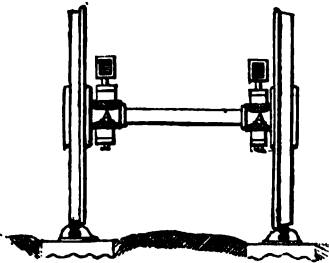


Fig. 3.

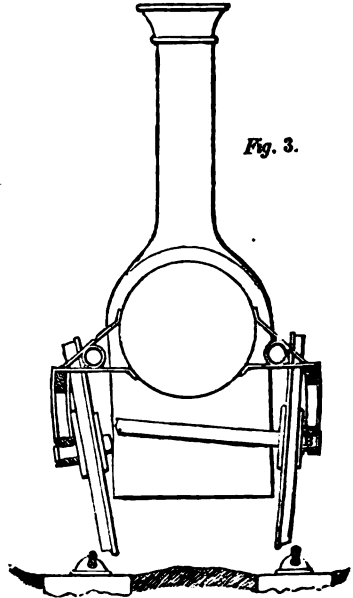
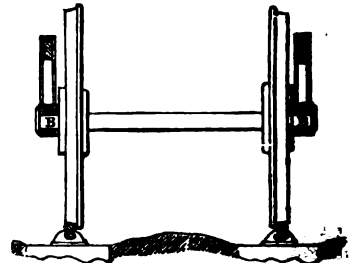


Fig. 4.



**Explanation of Figs. 1 and 2.** In this Engine the bearings are inside the wheels, and the weight of the engine and boiler is carried at A A. The tendency of the axle therefore is to bend downwards in the centre, whilst the pressure of the flange against the rails in going round curves has a contrary tendency. Thus, one strain counteracts the effects of the other; and, if the axle breaks, the wheels can spread out no farther below than the amount of allowance for play between the flange of the wheel and the rail. The wheels therefore being confined between the rails by the flange pressing against the inside of the rails, may proceed with safety to the next station.

**Explanation of Figs. 3 and 4.** The gravity or insistent weight of this Engine with outside frame, is carried at B B outside the wheels. The gravity of the entire engine and boiler in this case, tends to bend the axle upwards in the middle, and the pressure of the flange of the wheels against the rails in going round curves, acts in the same direction, and in addition to it. This continued bending of the axle destroys the fibre of the iron, and ultimately it breaks; and when it is broken, the tendency of the axle upwards, as before shown, forces the wheels between the rails, there being no outside flange to prevent it, as is shown in Fig. 3.

Had we space to go into the subject at large, we could show by reference to authentic official documents that "A Practical Engineer" has committed himself on several points, but we have only room to admit a short letter,

addressed to the Editor of the *Mechanics' Magazine*, signed J. G. S. (vol. xxxvii. page 246,) which completely disproves the assertions of the before-mentioned gentleman on some very important points. The letter states, "Your correspondent, the 'Practical Engineer,' asserts, that the engines of Messrs. Bury and Co. on the London and Birmingham railway, consume more coke per mile per carriage, than those on the Liverpool and Manchester. He also says, that, on the Grand Junction railway, one engine is employed to draw a train of equal weight, and at an equal speed, to one which on the London and Birmingham requires two engines. Now, the annexed tables will show the *opposite* to be the case on the Grand Junction; and from Time-tables in Pambour's *Treatise on the Locomotive Engine* (pp. 312, 313) I find the average quantity of coke consumed on the Liverpool and Manchester to be about the same as on the Birmingham, though in no case does it average so low as 29lbs. per ton per mile, as in the annexed tables. The 'Practical Engineer' says also, that in his opinion, Messrs. Bury and Co's. inside frame is very defective in point of durability. Perhaps he will give his *reasons* for thinking so, and show the advantage of the heavy outside framing of wood.

" J. G. S."

EXPERIMENTS ON THE GRAND JUNCTION LINE.

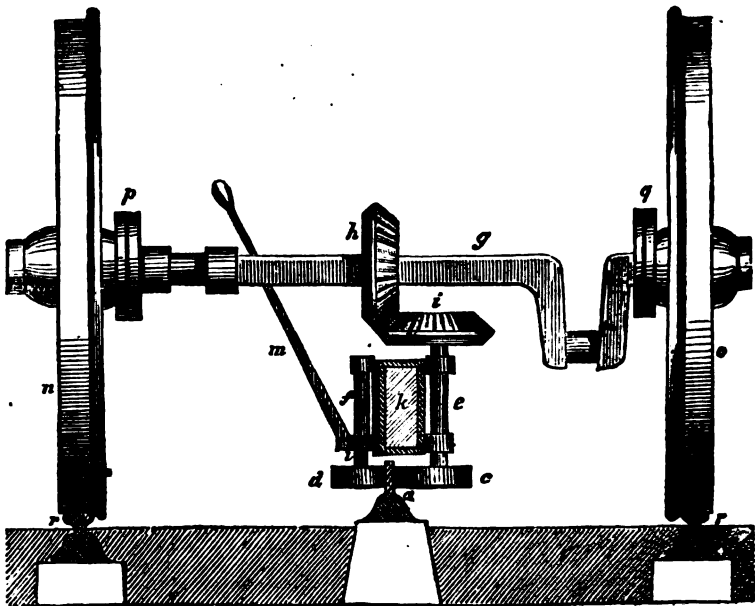
Name of Engine.	Date.	Gross Load in Tons.	Mean Speed in Miles.	Coke per Mile in lbs.	Coke per ton per mile.
PHALARIS.....	{ May 20..... }	.....59.2.....	.....23.05.....	.....37.03.....	.....62.....
	{ May 31..... }				
	{ June 1..... }				
PROMETHEUS.....	{ June 5..... }	.....58.7.....	.....22.53.....	.....34.3.....	.....60.....
	{ June 6..... }				
	{ June 7..... }				
	{ June 8..... }				
PROMETHEUS.....	{ June 11..... }	.....52.8.....	.....22.30.....	.....41.9.....	.....79.....
	{ June 12..... }				
	{ June 13..... }				
PHALARIS.....	{ June 14..... }	.....62.6.....	.....22.06.....	.....38.5.....	.....61.....
	{ June 15..... }				
	{ June 16..... }				

EXPERIMENTS ON THE LONDON AND BIRMINGHAM LINE.

Descriptions of En- gines.	Gross Load in Tons.	Mean Rates.	Coke per ton per mile.
Twelve inch Cylin- ders and 5 feet Wheels.....	.....50.15.....	.....30.51.....	.....47.....
.....	.....70.95.....	.....28.53.....	.....43.....
.....	.....81.61.....	.....21.86.....	.....35.....
Twelve inch Cylin- ders and 5 feet Wheels.....	.....50.77.....	.....31.29.....	.....55.....
.....	.....69.76.....	.....29.82.....	.....41.....
.....	.....83.53.....	.....19.42.....	.....29.....

*Ascending of Inclined Planes.*—One of the chief difficulties in the application of locomotive carriages to railways has been to obtain sufficient friction or adhesion between the driving wheels and the rails to cause them to ascend planes of considerable inclination, as the wheels are in such cases apt to be turned round without advancing the carriage. To prevent this, Messrs. Vignoles and Ericsson, by their patent of 1830, proposed to introduce a third or friction rail between the two bearing rails. This friction rail consists of a flat piece of iron extending along the middle of the road, and securely fixed in a vertical position, as represented in section in the annexed figure. On each side of this friction rail, which is made of considerable depth, is placed a horizontal friction roller, as shown at *c, d*; the roller *c* being made considerably larger than *d*, and fixed upon its vertical shaft *e*, while *d* is permitted to turn freely on its vertical shaft *f*. On the driving axis *g* is fixed a bevel wheel *h*, which turns another bevel wheel *i*, fixed upon the vertical shaft *e* of the driving roller *c*. The bearings of this driving roller and its shaft are firmly fixed to the under side of the locomotive carriage by the block shown at *k*, and the bearings of the friction roller *d* are ninged to the block at *l*, that it may at pleasure be pressed against the friction rail *a*, by the lever *m*. This lever is wrought by bringing it within reach of the engineer or his assistant, who, acting upon the

long arm of a powerful lever, causes any degree of pressure upon the friction rail by *nipping* it between the rollers *c, d*; at the same time the driving wheels *n* and *o* of the carriage are released, and permitted to turn independently of the driving axis *g*, by shifting the binding rings *p, q*. When the friction driving apparatus is in action, the wheels *n* and *o* become simply supporting wheels



and run on the supporting rails *r, r'*. The patentees confine their claim to the driving apparatus which we have described, though they state that it may be put in motion through the medium of the driving axis, by the steam engine employed to actuate the driving wheels of the usual construction, or a separate cylinder may be employed to give motion to the patent driving apparatus. The depth of the friction rail *a* must necessarily be varied to correspond with the inclination of the steepest plane on which it is to be applied.

There is evidently considerable ingenuity displayed in these arrangements; but we doubt whether the patentees have hit upon the readiest way of obtaining an increase of adhesion by an increase of the surface, and pressure of the moveable and stationary parts in contact.

*Kollman's Locomotive Guides.*—To prevent locomotives running off their lines of rails, Mr. G. A. Kollman proposed (by his patent of 1836) to attach a vertical arm or bracket underneath the carriage, furnished with anti-friction rollers, that bear laterally against a central rail, to be placed midway between the ordinary rails. He proposed two modes of effecting this, which differ but slightly from a variety of suggestions of the same kind, and for the same object, but as there were strenuous efforts made a short time since to get Mr. Kollman's plans adopted on certain lines, we feel it incumbent upon us to give a brief description of them. The first mode was to form a trench with a metallic case to it below the surface of the road, and to cause the anti-friction rollers to act against the sides of the case; the second was to fix a middle guide rail above the ground and cause friction rollers to operate on each side of it.

In the annexed cut *Fig. 1*, is represented at *a* the vertical arm, extending from the under part of a rail-road carriage; to which arm, as an axle, an anti-

friction roller *b* is attached; *c* is the metallic case to the trench; against the sides of which the roller is intended to act, as the carriage travels along, the wheels of which are restrained from running off the rails, by the flanges *d d* not permitting the carriage to rise.

Fig. 1.

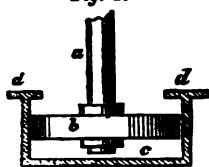


Fig. 2.

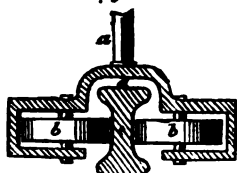
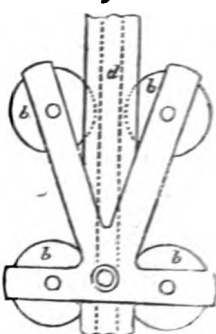


Fig. 3.



Figs. 2 and 3 are explanatory of the other mode mentioned. At *a* is the vertical arm; *b, b* the anti-friction rollers acting against the sides of the middle rail *c* as the carriage proceeds, the broad top *d* of the said rail keeping the rollers in their places and preventing the carriage from rising. For the better guidance of the carriage in its true course, there are to be two pair of rollers *b, b*, placed at a short distance one before the other, and mounted in a frame of the kind delineated in the annexed Fig. 3.

The patentee appears to be aware of the paucity of originality in his scheme, and confines his claim to invention in the application of the "top flanges, to prevent the carriage rising."—*London Journal*, for July, 1841.

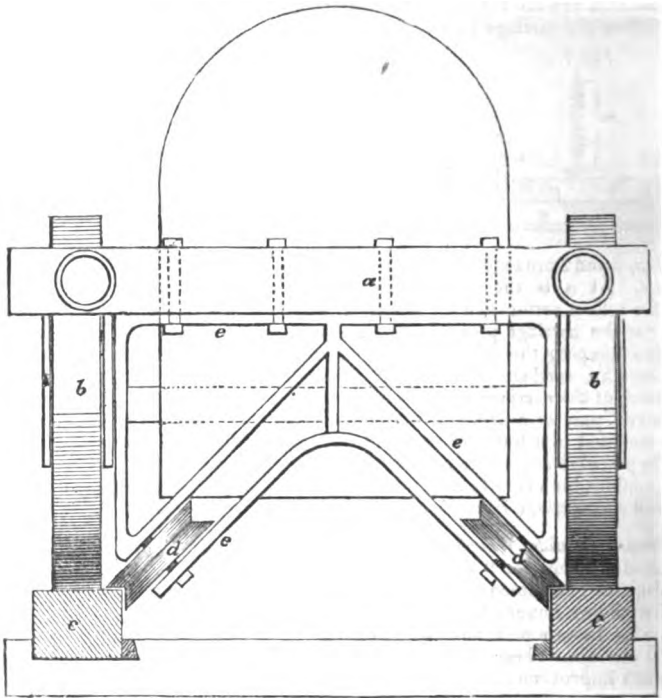
*Prosser's Guide Wheels and used in railway.*—In 1844 Mr. W. Prosser obtained a patent for "Improvements in the construction of railways and in carriages to run thereon;" the latter improvement consisting in the removal of the guiding flanges from the periphery of the bearing wheels, and substituting for them a peculiar arrangement of guide wheels attached to the frame of the carriage. These guide wheels were devised chiefly with reference to Mr. Prosser's improvements in the construction of railways, in which he proposed to substitute for the iron rails, continuous bearings of solid Kyanised timber.

But as these guide wheels are applicable on railways of the ordinary construction, and as the arrangement appears to exhibit considerable ingenuity, and to possess much practical merit, we subjoin a short description of it. We may observe that the idea of employing guide wheels instead of flanges on the bearing wheels to keep the carriages on the rails is not new; indeed we have in the course of this treatise noticed several plans for this purpose, but we believe that by all previous arrangements a third or additional rail was required for the guides to act upon; whereas in Mr. Prosser's plan no additional rail is requisite as the guides act upon the bearing rails, and possess this great advantage, that in the event of breaking of an axle they would support the carriage and enable it to continue its course.

An end view of a locomotive with these guide wheels attached is given in the following engraving.

*a a* is the engine frame, *b, b* the bearing wheels, *c, c* the wooden longitudinal bearers before mentioned; but for which may be substituted the ordinary iron rails: *d, d* are the guide wheels turning upon pivots in a frame *e* attached to the end of the frame of the engine. These wheels are placed at an angle of 45° with the horizon, and have an angular groove in their periphery, one face of the groove being horizontal, or parallel to the surface of the rail, and the other face being vertical or parallel to the side of the rail. The distance between the guide wheels is a little less than the distance between the rails, so that when the carriage is proceeding in a straight direction the guide wheels do not come in contact with the rails; but when the carriage deviates to one side, the guide wheels on that side are brought immediately into action, and prevent further deviation.

Mr. Prosser's rails and wheels have, we believe, been adopted on the Guildford and some other lines of railway.



*Stephenson's Compound Axles.*—In the specification of a patent granted to Mr. Robt. Stephenson in 1831, he informs us that in the carriages previously used on the Manchester and Liverpool railway, each pair of wheels was fixed fast on the two opposite ends of a long solid axis, which revolved with the wheels, and the two extremities of the solid axis, which projected through the centres of the wheels, were formed into pivots or gudgeons and were received into suitable sockets, whereon the weight of the carriage was borne by the concavities of those sockets pressing downwards upon the pivots. In travelling with great rapidity, the said pivots required a copious supply of oil, and much of it was wasted, because the concavities of the sockets being inserted, the oil had a tendency to run down and escape from the places of bearing where it was wanted. According to the improvement of 1831, Mr. Stephenson's plan consists in fixing the pair of carriage wheels fast upon the extreme ends of a long hollow, or tubular axis, within which a solid central axis is inserted, extending through all the length of the hollow, and projecting out sufficiently beyond each of the hollow axes to enable the weight of the carriage to be supported upon the projecting ends of the solid central axis, around which the hollow axis turns, together with the two wheels, which are both fastened upon the ends of the hollow axis, to prevent one wheel from advancing either faster or slower along one rail than the other wheel advances along the other rail.

In the subjoined figures—*Fig. 1* represents a vertical section through the centre of the wheel to show the novel arrangements of the parts, and *Fig. 2* a side elevation of the same.

At *a a a* is the solid axis, enlarged at *a*; *b* is the tubular axis, passing through the central boss *c* of the wheel *d d*, and bolted to the same as shown at *e e e e*

through a circular plate *f* front. The weight of the carriage is supported at *g g* on the projecting part of the axis *a*; which is received into a solid metal socket *h*, made in two halves, and screwed together by four bolts *i i*, and two staple

Fig. 1.

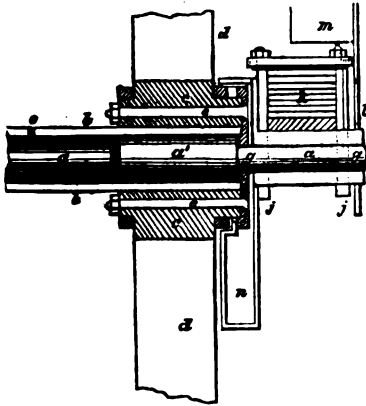
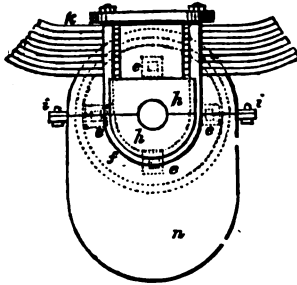


Fig. 2.



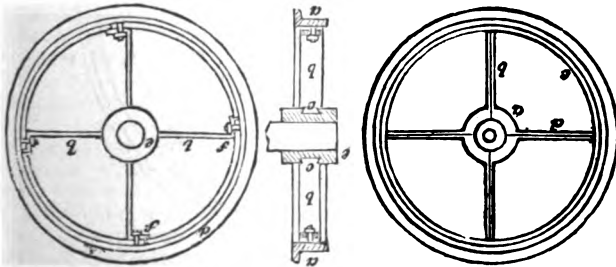
bolts *j j*, which fasten the springs *k* down across the upper flat sides of the socket *h*; thus the two halves of the socket are bound firmly together by the said screws around the end *g* of the solid axis, and secures them together. The outer end of the socket *h* is fitted into a vertical groove formed in the space between the prongs of the guide plate *l*, which is screwed to the horizontal side rail *m* of the carriage, as shown in *Fig. 1*, and projects downward therefrom. The oil is supplied at an aperture *o*, provided with a screw plug, and finds its way between the rubbing surfaces of the axis, and the portion that escapes past the bearings is received into an oil box *n* of cast iron, made in two halves for fitting it on to its place.

*Losh's Patent Railway Wheels.*—Some improvements in the construction of wheels for railway carriages were patented on the 31st of August, 1830, by Mr. Wm. Losh, of Bentom House, in Northumberland, a gentleman whose experience and knowledge in matters of this kind entitles his suggestions to the attention of the public.

Fig. 1.

Fig. 2.

Fig. 3.

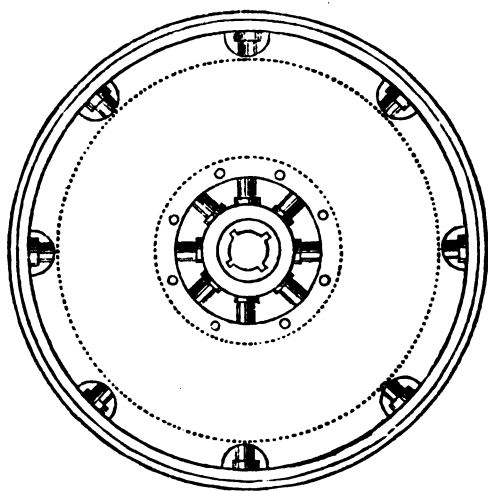


The nature of this invention will be at once understood from inspection of *Figs. 1* and *2*, where *a a a* represent the tire and flange of a wrought-iron railway wheel; *b b b* spokes which are to be made dove-tailed at one end, and cast into the nave *e*, as shown in section at *c c*, *Fig. 2*. The other end of the

spoke has a right angular crank bend, as shown at *fff*, *Fig. 1*; being carried round the circle to the next spoke; and thus each spoke and its adjoining fellow are made of one piece of iron. By means of the crank bend at the end of the spokes, one fellow is permitted to pass over the end of another, and at this double part they are securely fixed together by strong screws, as shown by dotted lines. The tire is formed (in passing finally through the rollers at the iron works,) with a recess for the fellow, and a flange to keep the carriage on the railroad, as represented at *a a*; and it is to be heated and fitted on the wheel in the usual manner, that it may contract and firmly grasp the wheel when it contracts in cooling. The ends of the spokes, too, must be made hot before the nave is cast upon them, that the junction of the two metals may be the more perfect. It is stated that it may be sometimes found more convenient to weld several pieces of iron together than to bend one piece twice at right angles. It is likewise stated that the spoke may be sometimes with advantage welded on the middle of a piece extending along a ring constituting the fellows in both directions.

*Lessening the vibration and noise of Railway Wheels.*—It is now generally understood that the rapid deterioration as regards the strength of railway wheels and axles, is chiefly caused by the intense vibration to which they are subjected. This can readily be made evident:—if the journal of an old railway axle is struck with a smith's hammer, it will in many cases break off with a single blow; presenting at the fractured part a weak brittle appearance; whereas the journal of a new axle will take several hundred blows before breaking, a tough fibrous appearance being presented at the fractured part.

Mr. Lipscomb's apparatus for preventing the vibration of wheels is very simple, and we believe efficacious. It has been applied, we understand, to one of the Royal carriages on the Birmingham and London railway. It consists of a plate of zinc placed on each side of a wheel, for the purpose of retaining saw-dust in contact with part of the rim and spokes; each plate has two wooden rings of unequal size permanently fixed to it; the external diameter of the



smaller ring, and the internal diameter of the larger ring are shown by dotted circles in the annexed figure, and are likewise flush with the edges of the zinc plates. The combined depth of the corresponding rings is equal in width to the tyre; these rings meet and are screwed together, certain parts of the rings being cut away to let in the spokes. By a reference to the figure it will be

seen that the ends of the spokes, adjoining the nave and tyre, are left exposed for the purpose of noticing any defect which may take place in those parts.

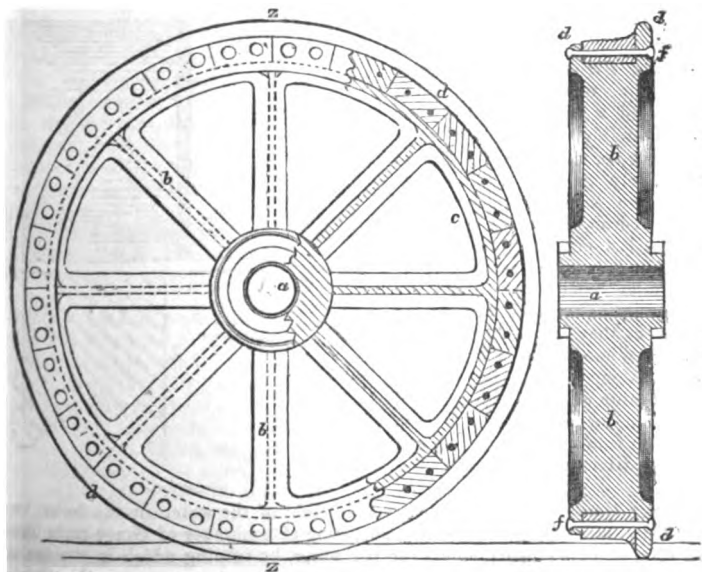
The apparatus may be detached from the wheel, by simply taking out the screws which hold the corresponding rings together, and is applicable, with slight modifications, to all existing metal wheels. The cost of the apparatus is 1*l.* per wheel, and it will last for many years.

Wheels formed of a combination of wood and iron are in partial use upon some railways for the purpose of decreasing noise and vibration, which still exist, notwithstanding, to a very considerable extent.

*Dircks's Wheels.*—At the meeting of the British Association at Glasgow in 1840, Mr. H. Dircks exhibited a wheel of a novel construction, invented by him, which had been running for several weeks on the St. Helen's railway with very satisfactory results. The construction of the wheel will be understood by imagining an ordinary spoked wheel, but with a deep channelled tyre, as seen in *Fig. 2*. In this channel are inserted blocks of African oak, measuring about 4 in. by 3½ in., prepared by filling the pores with unctuous preparations, to counteract the effects of capillary attraction in regard to any wet or dampness, by which it becomes impervious to either. There are about 30 of these blocks round each wheel, cut so as to fit very exactly, and with the grain placed vertically throughout, forming a kind of wooden tyre, each block being retained in its place by one or two bolts *Figs. 3 and 4*, the two sides of channel having corresponding holes drilled through them for this purpose. The bolts are afterwards all well riveted. After being so fitted, the wheel is turned in a lathe after the ordinary manner of turning iron tyres, when it acquires all the appearance of a common railway wheel, but with an outer wooden rim, and the flange only of iron. Mr. Dircks proposed using either hard or soft woods, and various chemical preparations to prevent the admission of water into the pores of the wood; he also contemplates the using of compressed woods.

Fig. 1.

Fig. 2.

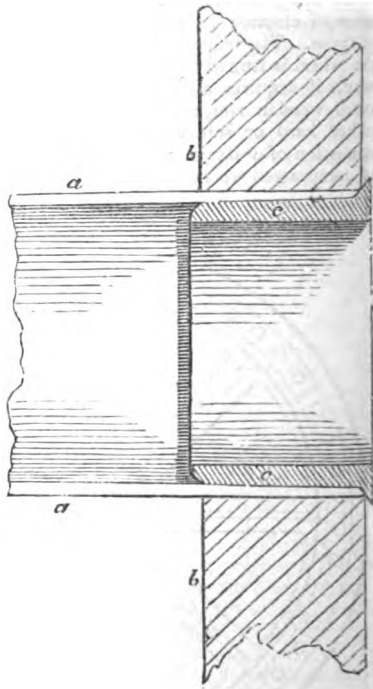


The annexed figures represent one of these wheels, *Fig. 1* being a front elevation, (partly in section,) and *Fig. 2*, a vertical section through the line Z.



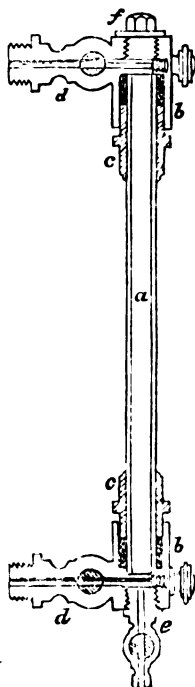
*a* is the boss; *b b* the arms; and *c c* the rim or felly of the wheel, having deep flanches *d d* on each side, forming a circular groove or trough round the periphery of the wheel. In this groove or trough are inserted the blocks of wood *e e* (before mentioned), which are retained in their places by bolts *f f* passing through them, and riveted outside the flanches. The several advantages which this wheel possesses, are represented by him to be,—that the wooden tyre will wear a considerable time without requiring any repair; that the tyre can be refaced by turning it up again in the lathe, as practised with worn iron tyres; that it can be re-tyred with wood at little expense, and at a far less loss of time than usual; and that both in the operations of refacing old tyres, or putting on new wood, the work can be performed without the usual labour and cost of unkeying, as the whole can be done while the wheels remain on the axles. One very important advantage yet remains, and that is, that the rails themselves will suffer less-wear by using these wheels, and the fastenings, sleepers, and blocks, not be nearly so much injured.

*Mode of fixing tubes in locomotive boilers.*—These tubes are made of the best rolled brass, one thirteenth of an inch thick, the edges of the brass are properly chamfered, and lapped over each other, and soldered together, the solder being applied inside; the tubes are then drawn through a circular steel die, to make them truly cylindrical. The holes to receive them in the tube plates *e* and *n*, are bored quite cylindrical, so as to fit the tubes exactly, which are just long enough to come to the outside of both plates; the ends of the tubes are then fixed by driving in a steel hoop or ferrule made slightly conical, as shown in *Fig. 1*, which is a section full size of the tube *a a*, the plate in which it is inserted, and the ferrules *c c*; the ferrule is a little larger than the tube, so that when driven in, it compresses the tube very forcibly against the sides of the hole, and makes the joint completely watertight. The ferrules are sometimes made of wrought-iron, but they generally do not last out the tube in that case, and require replacing by new ones before the tubes are worn out. The steel ferrules are better, as they last nearly twice as long. When a tube or ferrule requires taking out, the ferrule is to be cut quite through with a chisel and then turned inwards, so as to detach it from the tube, which can then be driven out.



*Water Gauge.*—In order to show the height of the water in the boiler, two methods are employed; the first consisting of a number of gauge cocks fixed at 2 or 3 inches apart, one over the other, by turning which in succession, the engineer ascertains whether they are open to water or steam: the other is by an instrument called the water gauge, which consists of a strong glass tube *a*, about three quarters of an inch diameter outside, fitted into a brass socket

*b b* at top and bottom, the joints being made steam tight by hemp packing put round the glass, and compressed against it by the glands *c c*, which are screwed in round the glass. From each of the socket pieces *b* a tube *d* proceeds with a cock in it, and a screw on the end, for fixing it into the fire-box, and the piece *e* containing another cock is screwed into the lower piece, and the plug *f* into the upper piece, affording the means of putting the glass tube down into its place. When the two cocks in *d d* are opened, the water of the boiler rises in the glass tube to the same height that it is in the boiler, the upper part of the glass being filled with steam, and so remains, shewing always the level of the water in the boiler; the cocks are for the purpose of stopping the communication when required, from the gauge being out of order or otherwise. The cock in the piece *e* is for the purpose of clearing out the gauge, by allowing a stream of water to run through it, and it is often necessary to open it when examining the gauge, in order to get rid of the bubbles of steam formed by the rapid ebullition of the water, which sometimes render it difficult to ascertain the precise height of the water. The difficulty is also increased by the motion of the engine, producing oscillation in the water, but the disturbing effect is much diminished by choking the tube or making the communication with the boiler through the tube *d* very small, so as to impede the motion of the water in the tubes. A small plug *g* is screwed in opposite each tube *d*, to afford the means of clearing out the tubes *d*, by passing a wire through them when the plugs *g* are taken out.



*Melling's water ash-box.*—Instead of the ordinary thin plate, which is usually suspended below the furnace, for the purpose of receiving the falling cinders, Mr. Melling employs a shallow tank containing three or four inches depth of water, supplied from the tender by means of a pipe and stop-cock. The falling cinders, and the radiating heat from the furnace, consequently heat the water in the tank, which, being returned into the tender, raises the temperature of the water therein, and effects an important saving of fuel. To render this operation self-acting, the boiler is furnished with a ball valve, loaded with 50lbs. on the square inch, so that at such pressure the steam will escape and pass into the water tank, and become condensed. By this arrangement, the boiler may be always supplied with water at or near the boiling point.

*Buffers* are strong elastic cushions, placed at each end of the carriage, connected with a system of springs, to deaden the effects of concussion. They are variously constructed.

The following *Fig. 1* represents a side elevation of one of the Dublin and Kingstown railway carriages, with Mr. Bergin's invention applied to the same. *Fig. 2* is a plan of the under part of the same, the body being removed. *a a* represents a slight frame, made of two similar plates of iron, screwed to each other about three inches apart, and resting upon turned bearings in the centres of the axles. A wrought-iron tube *b b*, about three inches in diameter, the entire length of the carriage, and extending about two feet beyond each end, is supported on this frame by rollers, which allows the tube to be moved thereon lengthways with facility. On this tube is placed, at either end, within the frame of the carriage, about four feet of helical springs *c c*, of graduated strengths; one end of each of these sets of springs abuts against a strong collar *d*, fixed to the tube *b*, and the other end against a small box of iron attached to the frame,

and furnished with one of the bearing rollers before mentioned, also with two friction-rollers resting against the inner side of the carriage-frame end. To each extremity of the tube *b b* is attached a buffer-head *ff*, by means of a rod of iron passing through the tube, and connected to the buffer-heads by screwed nuts sunken below their surfaces. At the back of each buffer-head is a cross-bar *g*,

Fig. 1.

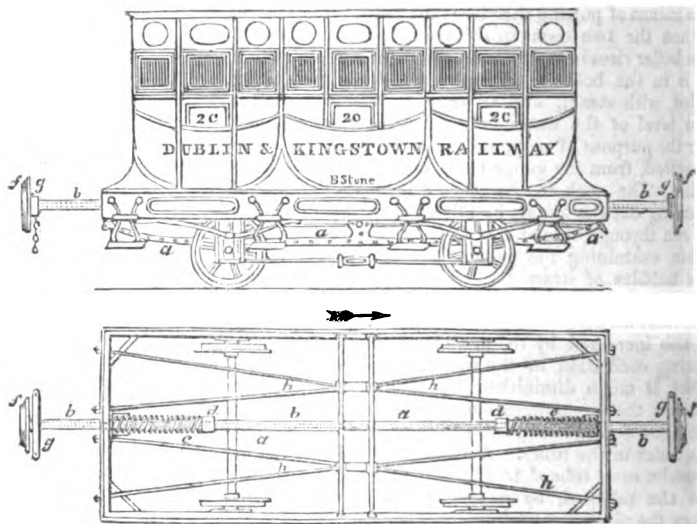


Fig. 2.

to which, by chains and hooks, the carriages are attached together. This apparatus lies loosely on the axles, and is perfectly independent of the framework of the carriage, which is sustained by springs in the usual manner; and there are long vertical slots made in the framing, through which the buffing-tube passes, which permits the frame to rise or fall, according to the pressure of the load thereon, without affecting the height of the buffing apparatus above the road.

The action is as follows:—The train being moved in the direction of the arrow, the locomotive power is applied to the cross-bar *g*, and draws forward the central tube *b*, thereby compressing the springs *c c* between the collar *d d* and the friction roller box, which rests against the end of the carriage frame, without moving the latter, until the elastic force of the compressed springs becomes sufficient to overcome the resistance presented by the friction of the carriage and load. The carriage then begins to move forward, so slowly as almost to be imperceptible to persons seated within; the second and each succeeding carriage in the train is by similar means brought from a state of rest into motion. In case of one carriage running against another, the resistance is offered by the furthest end; the effect being to drive the tube *b* forward, compressing the springs at the opposite end from which the concussion is given, and the carriage will be but little affected by the blow, until the elasticity communicated to the springs by compression overpowers the resistance of the carriage, which then begins to move, actuated by a force just sufficient to start it. The coiled springs have a range of action of about two feet, beginning to be compressed by a force equal to about twenty pounds, and presenting a total resistance to entire compression of upwards of two tons. A spring of this strength, the patentee states, has been found suitable for carriages weighing, when loaded, about four tons. It will be observed, that the entire resistance to the action of the springs is on the ends of the carriage frame: the

middle of each is armed with a strong plate of iron, about fifteen inches square, through which pass the tension rods, *h h*, *Fig. 2*, to the outer angles of the opposite ends of the frame; consequently, the rods receive the entire force of the springs. The springs at either end of each carriage act totally independent of those at the other end, and of all the carriages in the train, except that to which they are attached; each has, therefore, to bear only its own share of the resistance of the entire train, the sum of which is made up of the separate resistances of all the springs acted upon.

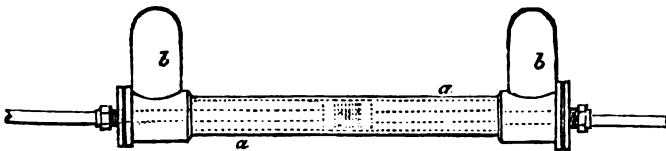
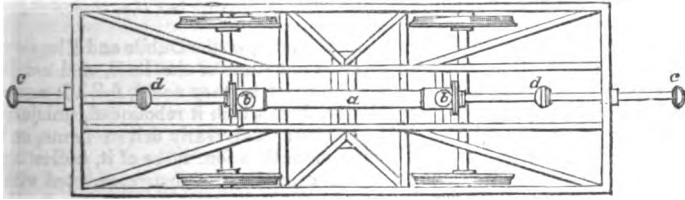
*Mallet's Buffers.*—Robert Mallet, Esq. of Dublin, in a communication to the Editor of the *Mechanic's Magazine*, has described an ingenious and original plan of buffing, an extract of which we shall proceed to give. Mr. Mallet observes;—"The employment of elastic fluids to serve as springs, has been frequently proposed, and occasionally brought into practice, but never upon a large scale, or with very successful results. This has arisen, principally, from the fact, that it is impossible to make any cylinder and piston, or any rod and stuffing box, absolutely and permanently air-tight, especially under the effects of sudden and violent compressions: hence, the air, or other elastic fluid used, has always been found gradually to escape from the vessel provided for its compression, leaving the whole apparatus springless.

"Yet, if this difficulty be once overcome, the advantages accruing from the use of air (as the most available elastic fluid we have) as a spring, are very great.

"It remains as spring at all temperatures, and in all climates; and its properties are such, that the resisting energy of the spring increases with the amount of the force with which it is compressed or urged, and, by a suitable arrangement, may be made to increase according to any assignable law.

"My method of overcoming the one great obstacle to the use of air as a spring consists in confining the air to be compressed by a body of water, or other liquid; and is based on the well known fact, that joints or sliding surfaces can

*Fig. 1.*



*Fig. 2.*

readily be made *water-tight*, and kept so, which cannot be made or maintained *air-tight*.

"In the month of February, 1836, I designed a set of buffing apparatus upon this basis, which was constructed by the firm with which I am connected, and placed on the Dublin and Kingstown railway, attached to one of the open passenger carriages. *Fig. 1* shows a plan of the under carriage, fitted with the buffing apparatus; and *Fig. 2*, a side view of the air cylinder, &c. on a larger

scale. The system of *thorough* buffing, as invented by Mr. Bergin, the intelligent manager of the railway, is in use upon the Dublin and Kingstown line, and hence was adopted in the hydro-pneumatic buffer, as then designed. *a a*, is a truly bored cylinder of cast-iron, closed at each end by a cover, provided with a large gland or stuffing-box, through which the buffer rod passes, being turned truly like a piston rod, which, in fact, it is. The buffer rod, going from end to end of the carriage, passes right through the cylinder, and carries a solid piston, packed with leather collars and pressed leather caps, which when in a state of repose is situated in the middle of the length of the cylinder. At *b b* are two air vessels of a cylindrical form, with hemispherical ends cast on to the cylinder, and standing vertical upon its upper side when *in situ*. The capacity of each air vessel is equal to that of half the cylinder, minus the bulk of the piston and included portion of buffer rod. The diameter of the cylinder was 6 inches, and that of the buffer rods  $2\frac{1}{2}$  inches of solid iron. By means of a suitably situated screw plug, the whole of the cylinder was filled quite full of water, leaving the two air-vessels above it full of air, which by a condensing syringe, was brought to a density of one additional atmosphere, or to about 15lbs. per square inch, plus pressure.

“In this state of things, it is obvious that any force acting at one end of the buffer rod would compress the air in one air vessel and rarify that in the other, by carrying the central piston rod towards one end of the cylinder, and thus driving the water at that end up into the air vessel. It is also plain that, as the water will always remain at the lowest part of the vessel, it will be constantly interposed between the air and the only possible places of escape from the cylinder, namely, the end covers and stuffing boxes. The range of the buffer-rod was limited to two feet—a limit, however, which it is scarcely possible it could ever reach by any force, as the air would then be condensed into about one-fiftieth of its original volume; but as a further precaution the buffer heads *c c*, and the counter buffer-heads *d d*, were so arranged, that, at the extremity of the range any shock given to the buffer-rod would be visited upon and distributed through every part of the frame of the carriage. The whole buffing apparatus was secured by bolting to the frame of the under carriage, to which it became a firm and substantial spine or back-bone, as it were, increasing its strength, in place of breaking it.

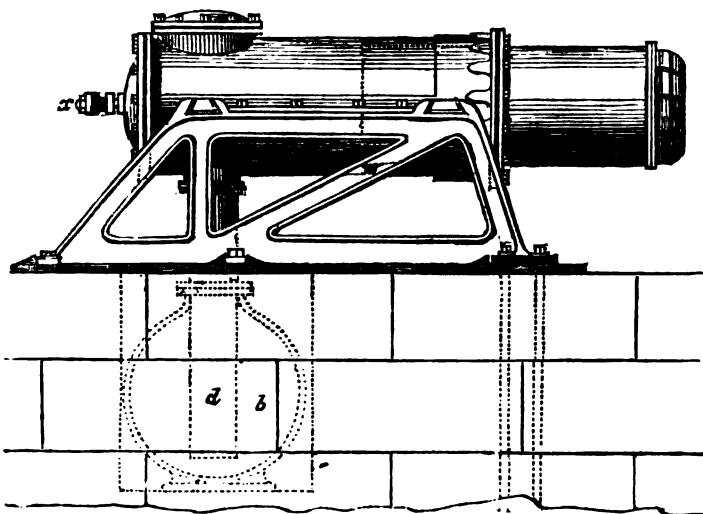
“The very first experiment made with this buffer, on the Dublin and Kingstown railway, consisted in bringing the carriage upon one of the lines, and causing 10 or 12 of the railway porters to run it, as fast as they could, full tilt against one of the stone walls of the station house, from which it rebounded, uninjured, like a piece of Indian rubber. The piston was not nearly driven home, or to its whole range, but had passed through more than four fifths of it, indicating a blow equal to more than 1500 lbs. The carriage was then connected with a locomotive engine, and drawn along the line, going at various speeds, stopping and reversing as suddenly as possible. The results were in every respect satisfactory.”

The before-described buffer continued in use as long as the under carriage lasted. About four years afterwards Mr. Mallett designed two improved forms of air buffers; one of them being intended for a great terminus buffer, to be placed in a station house or other similar situation, where trains require to be brought up without the possibility of running beyond a given point.

Page 479 is a side elevation of such a buffer. The construction is so simple as scarcely to need description. A large cast-iron cylinder, having a gland at one end, and closed at the other, is firmly secured down in a horizontal position to a mass of masonry, by lateral framing of cast-iron on a bed plate; the gland of this is filled by a turned cylinder of cast-iron, also hollow, bore of 36 inches diameter, open at its inner and closed at its outer end, which is armed with a large padded leather buffer-head. This cylinder is free to slide in the gland horizontally. The outer cylinder has at its lower side a large aperture, communicating with a spherical air vessel *b*, by a pipe *d* dipping into it; this is enclosed in a cavity of the masonry.

“This cylinder is filled with water, simply by pouring in at the top man lid,

which is then screwed down, and the buffer is ready for use. The air in the air vessels, which is here of about equal capacity with the cylinder, is of course permanently compressed with a force equal to a column of water of the altitude from the surface of the water in the air vessel to the highest part of the



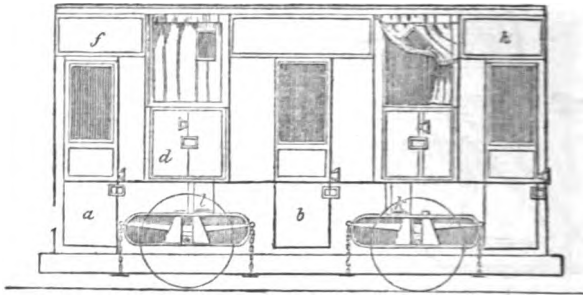
cylinder; and if any impulse be given to the inner cylinder, which may be considered simply as a large plunger or ram, it will be driven forwards into the outer cylinder, and in doing so will drive an equal bulk of water into the air vessel, compressing the air therein, the elastic resistance of which will increase in proportion to the compressing force.

"In this buffer, if the plunger be driven in half way, the air in the vessel will have a density of one atmosphere, and the total resistance afforded at this point would be 15,270 lbs. and so on; and if the plunger were driven in so far that ten atmospheres was the density of the air, the buffer-head would equilibrate a blow having a force of about 68 tons. The total range given here to this buffer is 3½ feet; but it is obvious that any length of range desirable may be given to such an instrument, so as to bring up a railway train with any required degree of gentleness. From the properties of elastic bodies, the plunger when struck by an imperfectly elastic system, such as a railway train, and driven in by it, would again rebound with considerable force, and would be liable to be driven wholly out of the gland: this is provided for by a turned rod, marked x, secured in the axis of the plunger, and passing through a small stuffing box in the back end of the outer cylinder, and having a large nut, and a number of leather collars to deaden the blow upon its extremity: this catches the plunger on the return stroke. Such is the method I propose for bringing up a train at a station."

Mr. Mallett next proceeds to describe another modification of his hydro-pneumatic buffers to railways, for which we must refer the reader to vol. xxxv. page 422 of the *Mechanic's Magazine*.

Mr. Curtis, who was some time manager of the Locomotive department of the Greenwich railway, with the view to increase the safety of the carriages by reducing the height of the centre of gravity, altered several carriages on that line, by suspending the frame of each carriage below the axle, instead of supporting it above the axle in the usual way.

*Curtis's Passenger Carriage.*—The carriage of which the following is a correct drawing was built as a pattern carriage for the Boston and Providence U. S. railway in 1836: it is made upon the same principle as those of the London and Greenwich railway company, viz.—It will be perceived upon reference to the



engraving, that it consists of five distinct compartments or coaches, the floor of three immediately upon the top of the frame, and twelve inches only from the surface of the rail, so that passengers step in and out with as much facility as from a sedan chair. The middle compartment has double seats, like a mail coach, and the two end bodies single seats like a chariot; the two bodies over the wheels have also single seats, and may be either close bodied or open with a leather curtain as drawn: passengers get in or alight by steps similar to those of a barouche; the spaces over the low bodies may be employed for luggage, forming a commodious safe dépôt for that purpose. If it should be desirable to form the mail coaches upon this principle, the space over the wheels may be formed into the holds, or receptacles for the mail bags; thus placing the heaviest load over the wheels; also, if desirable, the roof may be adapted for outside passengers. Mr. Curtis observes that "it is evident from the construction of this coach that it is absolutely safe, by no possible chance can it ever upset; it does not cost more than the railway carriages usually adopted, and by placing joggles upon the cross pieces of the frame, descending so low as to clear the crossings, and setting them back from the wheels little more than the breadth of the rail on each side, in the event of the wheels leaving the rail, the frame locks in with either the one rail or the other, and thus the carriage is retained to the rail under all possible circumstances. This is a very valuable point, for when it is recollected that almost every railway is formed for fully one third of its extent upon embankments without parapets, which renders it very dangerous for an engine or carriage to be thrown off the rails upon them, this arrangement provides a remedy for the case to be met by no other equally simple, cheap, and efficacious means."

The carriages upon the Greenwich railway were altered by Mr. Curtis from the old and general plan of those upon the Liverpool, Birmingham and other lines: this alteration was effected by simply inverting the frames.

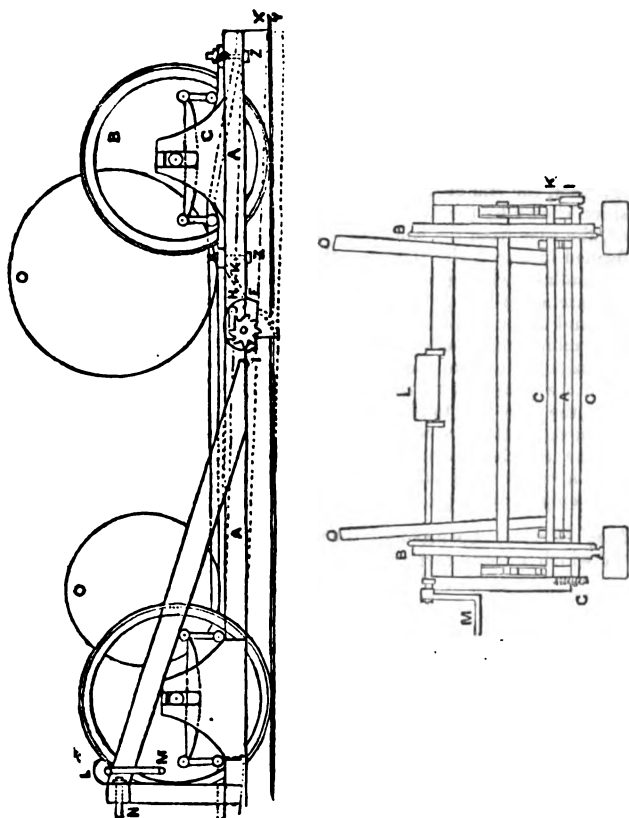
The following list of casualties upon the Greenwich line, which happened to the low carriages, speak volumes in favour of the absolute safety of the carriages.

"June 17, 1839, large open carriage with eight passengers, both axles broke, was dragged upwards of a mile, without the least injury to passengers.

"Aug. 21.—Axle of carriage broke, two passengers in the coach; dragged across the Croydon junction, and upwards of three quarters of a mile, without injury to passengers.

"Sept. 15.—Break carriage axle broke, with eight passengers; dragged upwards of a mile without injury to passengers.

"Upon two other occasions like accidents happened, with similar results, once in 1838, and the other in 1840."



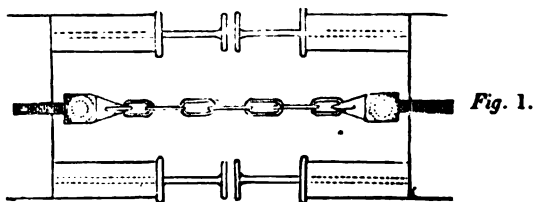
*Curtis's Railway Trucks.*—Mr. Curtis has applied the principle of construction just described to trucks for the conveyance of private carriages. *Fig. 1* is a side view, and *Fig. 2* an end view, and *Fig. 3* a plan of the machine: the same letters refer to the same parts of the machine in each *Fig.* so far as the parts are shown in each. *A* is the framing of the machine, which is suspended below the axle in the usual way; *B* the hind wheels connected with the shifting frame *C*, which frame is held in its place by the bolts *D D D*, or by any other usual and suitable means; *E E* are two eccentrics hung upon the cross shaft *F*, upon one end of which shaft the ratchet *G* is hung, and upon the other the head *I*, into the holes of which the lever *K* is inserted, when it is required to turn the shaft *F* round, so as to bring the eccentrics into contact with the rails or otherwise. *L* is a windlass placed upon the front bar of the machine, round which a rope coils, so that when a carriage is required to be placed upon the machine, one end of the rope is made fast to the carriage, and the other end to the windlass, then a man turning the windlass round by means of the handle *M*, the carriage is drawn upon the machine; the machine is connected to the train by means of the coupling *N* in the usual way, and the diagonal bars are placed as shown, in order that the concussion of the train may be transferred to the main frame of the machine *A*; *O O O O* are the wheels of the carriage placed upon the



machine: the body and carriage are omitted in the drawing, as it is not material to the explanation of the invention that they should be shown.

The mode of operation is as follows:—when a carriage is required to be placed upon the machine, the eccentrics are brought upon the rails, and made to occupy the position shown by the dotted lines in *Fig. 1*, the effect of which is to raise the end of the carriage to which the shifting frame and wheels are attached, a space equal to that included between the shaded line *x* and the dotted *y*, and to support it whilst the frame *c* and wheels *b* are withdrawn; then the eccentrics are turned back until they occupy the position shown in the drawing, when the end of the machine is lowered to the ground, and occupies the position shown by the dotted lines *z z*. The carriage is then brought to the machine, the rope from the windlass is made fast to it, the floor of the machine being formed into an inclined plane; the carriage is dragged upon the machine by the windlass with great facility. When placed upon the machine the eccentrics are again brought into the position shown by the dotted lines, which raises the end of the machine; the shifting frame *c* and wheels *b* are connected with the machine, and made fast by the bolts *d*, the eccentrics are then brought into the position shown in the drawing, riding clear of the rails; the ratchet *e* and pall *h* are provided to retain the eccentrics in any position they may be placed in: the best way to effect all these operations, is to place the machine upon a turn-table, the fore wheels and eccentrics being upon the table, when the machine can be disengaged from the wheels, and placed to receive the carriage in a very simple and easy manner; the same operations apply if the machine is employed for goods, cattle, or any other purpose.

*Railway Carriage Connectors.*—The following engraving, *Fig. 1*, shows the mode in which railway carriages were at first attached together; which con-



sisted simply of a chain, the buffers of one carriage not coming in contact with those of another, but each carriage was allowed, when moving onwards, a lateral oscillating motion.

In the subjoined engravings, *Figures 2 and 3*, Mr. Booth's highly improved method of connecting them is shown. It is a most complete invention for the purpose, and consequently adopted on almost every railway in the kingdom. *a* is the connecting chain attached to the draw-bar of each carriage, and consists of a double working screw (working within two long links or shackles), the sockets of which are spirally threaded to receive the screw bolts, which are fastened together by a pin and cotter, so that by turning the arm or lever *Z* of the said screws, the connecting apparatus is lengthened or shortened at pleasure, to the extent of the long links or shackles above alluded to, in which they work. This screw-chain being placed on the hooks, or turned-up ends of the carriage draw-bars *d*, the buffers *b* of each adjoining carriage being first brought close, or nearly close together, the lever *Z* is turned round a few times till the draw-bars *d* are drawn an inch or two beyond their shoulders, on the face of the carriage frame *e*, stretching the draw-springs, to which the draw-bars are attached, to the extent of a fourth or fifth part of their elasticity; and by that degree of force attaching the buffers of the adjoining carriages together, and giving by this means, Mr. Booth states, "to a train of carriages, a combined steadiness and smoothness of motion at rapid speeds, which they have not when the buffers of each carriage are separate from those of the adjoining

carriage." *w* is a weight to keep the lever in a vertical position, and prevent the unscrewing of the chain when in action.

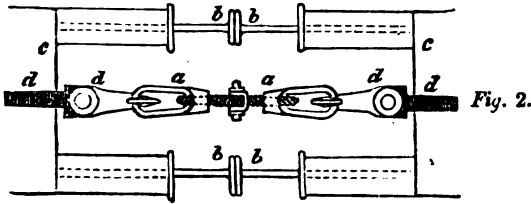


Fig. 2.

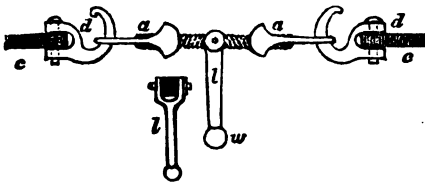
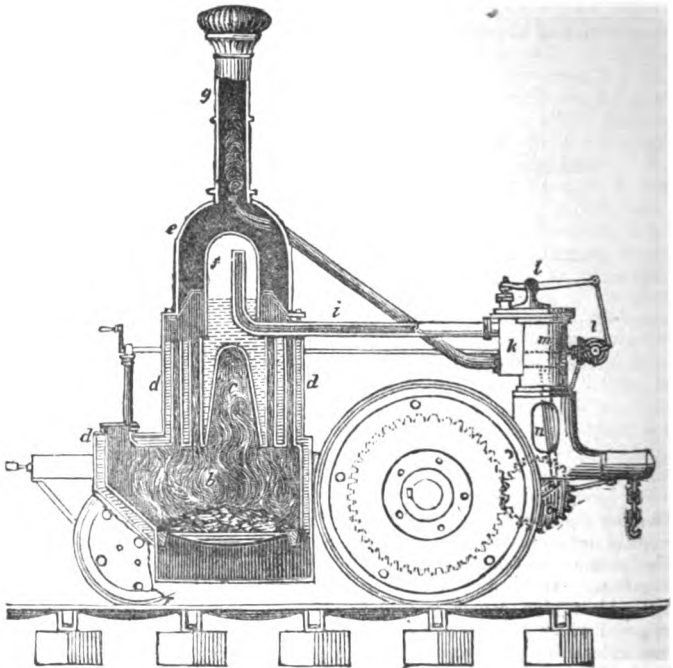


Fig. 3.

*Checking the speed, or stopping the Engine.*—In the same patent as the connecting apparatus just described, this very able and original minded inventor has included a novel method of checking the speed of the engine, or stopping it altogether. It is effected by introducing a throttle valve, slide, or damper, into the blast pipe, which is usually placed in the chimney in front of the engine, and which throttle valve may be most conveniently introduced where the two exhausting pipes are united into one, below the place where the pipe is contracted in area for the purpose of producing a blast to the furnace. From the throttle valve must proceed a rod or long handle extending through the chimney to the back part of the boiler, so as to lie within convenient reach of the engine-man, who, by moving the said handle, can close the slide or throttle valve, either partially, or altogether, as may be required. And the throttle valve need not be altogether steam-tight, but should be made to work freely in its place. The engine-man, when he wishes to stop or slacken the speed of the engine, closes or contracts his throttle valve without shutting off the steam in its passage from the boiler to the engine. The pistons, by that means, are speedily, but not suddenly or violently checked, and the driving wheels of the engine no longer revolving, or revolving very slowly, the engine is soon brought to a stand.

*Hick's Locomotive Engine.*—The annexed cut represents a side elevation of this remarkable engine; some of the parts, which could not well be explained otherwise, are shown in section. It was patented by Mr. Benjamin Hick, of Bolton, in October, 1834.

At *a* is the ash-pit, *b* the fire-place, opening above into a dome *c* of the boiler *d d*, and surrounded by water; the external figure of the boiler is that of a vertical cylinder; and as the dome *c* occupies the centre, the water chamber is for the most part of an annular form; this annulus has passing through it vertically numerous tubes open at each end, for the smoke and heated gases to pass from the furnace throughout the body of water, into the flue *e* above, and thence into the chimney *g*. The draught through the furnace is increased by introducing the induction steam pipe *k* from the engine into the throat of the chimney, where a jet of steam is thrown upwards, in the way now commonly practised. *f* is the steam chamber, enveloped in the heated gases that ascend from the furnace, which are made to impinge upon it with greater force by the introduction of a plate of iron shaped like an inverted funnel; *i* is the steam pipe, which conveys the steam from the chamber *f* into the valve boxes.



worked by a series of levers at *l*, that are put in motion by bevel gear, and a crank motion partly introduced. It is now to be clearly understood, that there are three steam cylinders *m*, but as they are all in a row, only one can be seen in our view; each of these cylinders is provided with suitable valves, and working gear, to admit the steam on the top only of each of the pistons, at the time of the descent of each, and to allow of its escape on their ascent. The bottom of each of the cylinders is open, and the piston rods *n* are jointed to the bottoms of the pistons, the latter being steadied in their motions by small lateral rods passing through guide holes. The three piston rods act directly upon a three-throw crank, the equi-distant positions of which in the circle cause the pistons to continue their reciprocating action, and the crank its rotative motion, with uniformity. Fast and slow motions, and clutch boxes for varying the speed, are provided in the usual way. In our diagram is shown a pinion *o*, on the crank axis, driving a wheel on the axis of the running wheels.

The patentee especially claims under his patent the combination of two or more cylinders, each having its lower end open, so that the steam shall press only upon the upper surfaces of the pistons, and communicate its power to the crank shaft, or running wheels, in a downward direction only; which he considers will cause a greater adhesion between the wheels and the rail, and less vibration to the carriage, than when the power is applied to the wheels in an upward and downward, or a forward and backward direction, alternately.

The wheels applied to this locomotive also possess some novelty, and are claimed under the patent right. They may be briefly described to consist of a cast-iron nave, duly formed and turned, to receive the edges of discs of plate-iron, in lieu of spokes; the felloes or external rings being fixed to the discs by first expanding their circumference by heat, and allowing them afterwards to contract, so as to receive the edges of the discs in grooves turned to receive them. The several parts are afterwards secured by bolts, screws, rivets, and keys, in a manner too well understood to need description.

*Patent Axle Grease.*—Every circumstance relating to locomotion on railways having become of importance, nothing escapes investigation, nor attempts at amelioration. Amongst the many matters to which attention is necessary to enable a locomotive machine to work well, is that of the lubricating substance. The sagacity of Mr. Henry Booth, of Liverpool, has led him to effect an improvement in this respect, for which he obtained a patent on the 14th of April, 1835; which he has denominated "The Patent Axle Grease, and Lubricating Fluid." These, according to the specification, are chemical compounds of oil, tallow, or other grease, and water, effected by means of the admixture of soda or other alkaline substance, in such proportions that the compounds shall not be of a caustic or corrosive nature when applied to iron or steel, but of an unctuous greasy quality, easily fusible with heat, and suitable for greasing the axle-bearings of carriage wheels, or the axles, spindles, and bearings of machinery in general. The proportions of the ingredients, and mode of compounding them, are stated to be as follow:

"For the axletrees of carriage wheels, a solution of the common washing soda of the shops, in the proportion of half a pound of the salt to a gallon of pure water. To one gallon of this solution add three pounds of good clean tallow and six pounds of palm oil; or, instead of the mixture of palm oil and tallow, add ten pounds of palm oil, or eight pounds of firm tallow. The tallow and palm oil, or either of them, and the solution as described, must be heated together in some convenient vessel to about 200° or 210° of Fahr. and then the whole mass must be well stirred or mixed together, and continually agitated, until the composition be cooled down to 60° or 70° of Fahr. and have obtained the consistency of butter, in which state it is ready for use."

The patent lubricating fluid, for rubbing the parts of machinery in general, is thus made: to one gallon of the aforesaid solution of soda, in water, add of rape oil one gallon, and of tallow or palm oil one quarter of a pound. Heat them together to about 210° of Fahr. and then let the fluid composition be well stirred about, and agitated without intermission until cooled down to 60° or 70°, when it will be of the consistence of cream. If it be desired thicker, a little addition of tallow or palm oil renders it so.

## SECTION IV.

### ATMOSPHERIC AND OTHER PECULIAR RAILWAYS.

Historical sketch and principles of Atmospheric railways.—Papin.—Medhurst.—Pinkus's patent.—Vallance.—Pinkus's first patent Atmospheric railway.—Pinkus's second patent.—Clegg's patent Atmospheric railway.—Dalkey line.—Mallett's report on Dalkey line.—Conflicting opinions on the Atmospheric system of traction.—Vignoles.—Cubitt.—Brunel.—Mr. Stephenson's report.—Herepath's report.—Bergin's evidence.—Pilbrow's Atmospheric railway.—Keene and Nicker's Pneumatic railway.—Hallette's Atmospheric railway.—Hallette's Pneumatic railway.—Taylor and Conder's electro-magnetic railway.—Saxton's Differential Pulley.—Badnall's Undulating railway.—Rope friction, Blackwall railway.—Farrill's Patent Archimedean railway.—Parker's Windmill railway.

THAT mode of propulsion which is effected by Pneumatic pressure, is generally known as the Atmospheric system of railway; from the circumstance of the elastic medium which we breathe being, in most cases, the impelling power. The practical introduction of this system is very recent, and our experience on the subject is consequently very limited. But it has numerous sanguine advocates and partisans; and is now, under variously modified forms, occupying the attention and study of different parties, who are devoting their talents and energies to perfect their several schemes, and bring them into practical operation. We propose first to describe such of the plans as have been carried into effect, and afterwards notice those modifications of the pneumatic principle of motion, which have been suggested as improvements upon the original idea.

The idea of imparting motion to machinery at a distance from the prime mover by the intervention of air, is by no means of recent date. As far back as the close of the 17th century, Papin (for whom the French claim the invention of the steam engine) suggested the plan, and we believe tried it, both by the compression of air, and by its rarefaction, but completely failed. Many years afterwards a trial of the plan was made upon a large scale in Wales, but with no better result, and the plan seems to have fallen into oblivion, when, in 1810, Mr. Medhurst of Denmark-street, Soho, published an account of a "new method of conveying goods and letters by air," followed in 1812 by a prospectus of a plan, by which he endeavoured to prove that goods and passengers might be cheaply and safely conveyed at a rate of 50 miles per hour. To effect this, he proposed to construct an air tight tube of sufficient dimensions to allow a carriage to run within it, and having a pair of cast-iron wheel tracks securely laid along the bottom, for the carriage to run upon. The carriage was to be of nearly the form and dimensions of the tunnel, so as to prevent any considerable quantity of air from passing by it; and the carriage was to be impelled along the tube by the pressure of air forced into the tube behind the carriage. Supposing the tube to be six feet in diameter, Mr. Medhurst calculated that to produce a speed of 50 miles per hour, would require a constant impelling power of 861 lbs. moving 73 feet per second, which he reckoned as equal to the continual power of 180 horses; and taking the consumption of fuel of a steam engine of that power at 12 bushels of coals per hour, 3 tons of goods might thus be conveyed 50 miles at a cost of 12 shillings, and at a speed of 50 miles per hour.

The plan attracted but little attention at the time, and was for a long period overlooked; but in 1824, Mr. Vallance of Brighton obtained a patent for a similar invention, with this difference, that he proposed to exhaust the air in the tube in the front of the carriages, instead of forcing it in behind them as in the

plan of Mr. Medhurst. Mr. Vallance subsequently constructed a short tube in his garden at Brighton, to demonstrate the practicability of the plan, and mention was occasionally made in the public prints of experimental trips which had taken place; but the apparatus was not of sufficient extent to show forth either the difficulties of the plan, or the extent to which they would be overcome; and this scheme, like the previous one of Mr. Medhurst, was never carried into effect.

The most obvious objection to the plans we have just described, is the necessity for the passengers to travel within the tube, excluded from daylight, and this alone would have been sufficient to prevent their ever being acted upon. This objection was first overcome by Mr. Pinkus, who by thus bringing the plan within the sphere of feasibility, may be considered as practically the inventor of the Atmospheric railway. His plans, it is true, have not been adopted in all their details as originally proposed by him, but, variously modified, they form the basis of the most promising schemes which have since been brought forward for propelling by the pressure of the atmosphere. Mr. Pinkus's first plan, and for which he obtained a patent in 1834, is fully described in the first part of the Encyclopedia, under the article "AIR;" it will be sufficient therefore in this place to say that it consisted of a tube laid down between a pair of rails on which the carriages were to run, and having on the top of it a longitudinal groove extending throughout its length. Within this tube was a piston, attached to the leading carriage of the train by an arm passing through the groove. This groove was closed by a thick cord, saturated with a composition of wax and tallow, in order to form an air-tight joint throughout the length of the tube, except at the part where the piston arm projected through the slit, where it was raised out of the groove by rollers attached to the arm, so as to leave an opening for the admission of the air into the tube, at the back of the piston. The tube in front of the piston was connected with an air pump, and a partial vacuum being formed in the tube, the pressure of the atmosphere upon the back of the piston would propel it along the tube, and with it the carriages connected to it.

In 1836, Mr. Pinkus took out a patent, for his second plan of atmospheric propulsion, which differs materially from his first, the travelling piston in the atmospheric main being dispensed with, and the system in some measure assimilated to the locomotive system. The following is a description of the plan, nearly as given in the Mechanic's Magazine:—A tube is laid down between two lines of rail, and communicates with air pumps placed along the line, which act upon the air in the tube, continually rarefying it as it is thrown in by the working of the locomotive apparatus. The main has an opening in the upper surface, two inches wide; on to the edges of this opening are attached plates, forming what Mr. Pinkus calls a metallic valve, made of an amalgam of iron and copper, hard rolled to make it elastic, 1-8th, of an inch thick at the lower edge, and 1-16th at the upper, (the insides of which are to be polished smooth,) and four inches high. The annexed cuts will show the thing more clearly. *Fig. 1* is a plan of the valve, and *Fig. 2* a cross section of the air main with the valve attached, and the tongue (afterwards described) between the lips of the valve. In both *Figs. a a* are the lips of the valve, which it will be seen, in their undisturbed state, by their elasticity press upon one another, and form an air-tight joint the whole length of the main. Working between the lips of this valve, is a hollow metallic tongue (*b Fig. 2*), the shape of which is seen in *Fig. 1*. The sides of this tongue in contact with the lips of the valve are polished, and the tendency of the latter to collapse, by their spring pressing upon these polished sides as they pass along, makes the joint air tight. This hollow tongue forms a communication through throttle valves, with a condenser or vacuum vessel, and this vacuum vessel communicates, through alternating openings, (somewhat similar to those used in steam cylinders, and worked by an eccentric from the crank,) with two cylinders in which work pistons, whose rods turn cranks which give a rotary motion to the wheels of the locomotive. The mode of action is as follows: the air in the main is kept rarefied by the exhausting engines at each end; a communication being made between it and

the rarefied air or vacuum vessel by opening the throttle valve, and between the vacuum and the cylinder by the sliding passage, a partial vacuum is formed under the piston, which the outward atmosphere forces down, giving half a turn to the crank; the alternating air passages are then reversed, the other piston is acted upon in the same way, and a revolution of the crank and consequently the carriage wheel is completed. The cylinder full of air, after having forced down the piston passes into the vacuum vessel, and through the hollow tongue into the main, from which it is pumped into the atmosphere by the stationary engines and air pumps at each end of the five mile section. As the tongue passes forward, it will open a passage for itself between the lips of the valve, which will immediately close behind it by the elasticity of the plates. The tongue is prevented from becoming hot by friction, by the current of cold air constantly passing through it from the cylinders.

Although this scheme manifests considerable ingenuity on the part of the inventor, we think it upon the whole inferior to his first plan. In particular we would notice that the advance of the train depends upon the adhesion of the wheels of the propelling carriage to the rails, so that in unfavourable states of the rails, the wheels would be liable to slip, and also the power of ascending inclines would be diminished, as on the present system of traction by locomotive steam engines, whereas by the first plan, provided a sufficient pressure could be produced at the back of the piston to overcome the friction of the load and the power of gravitation, the train must advance whatever be the state of the rails, or the steepness of the incline.

Mr. Pinkus endeavoured to form a public company, to carry his invention into effect, but did not succeed in so doing. His efforts however had the effect of drawing public attention to the subject, and provoking discussion; and paved the way for Mr. Clegg, who in 1839 took out a patent in connexion with the subject, and eventually succeeded in procuring its adoption by a company, and who may therefore be considered in one sense as the introducer of the Atmospheric railway. The title which Mr. Clegg selected for his patent was chosen very skilfully, and, although it certainly may be said to cover the invention, could at that period scarcely be supposed to refer to railways, and was therefore little likely to meet with opposition from parties who were directing their attention to that subject. The title is for a new improvement in valves, and the combination of them with machinery; but it will be seen that the improvements do not refer to valves in general, but solely to a continuous valve for the purpose of Atmospheric railways; the following is an extract from the specification:—

“ My improvements consist in a method of constructing and working valves in combination with machinery. These valves work on a hinge of leather, or other flexible material, which is practically air tight, similar to the valves commonly used in air pumps; the extremity or edge of these valves is caused to fall into a trough, containing a composition of bees'-wax and tallow, or bees'-wax and oil, or any substance or composition of substances which is solid at the temperature of the atmosphere, and becomes fluid when heated a few degrees

Fig. 1.

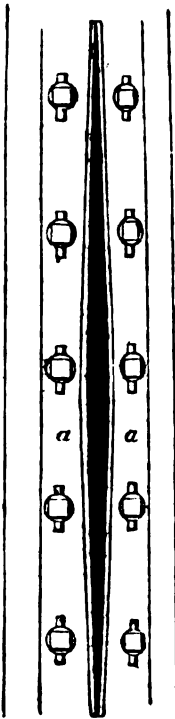
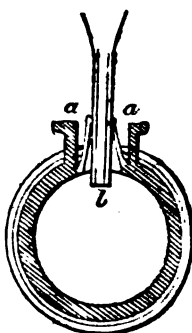
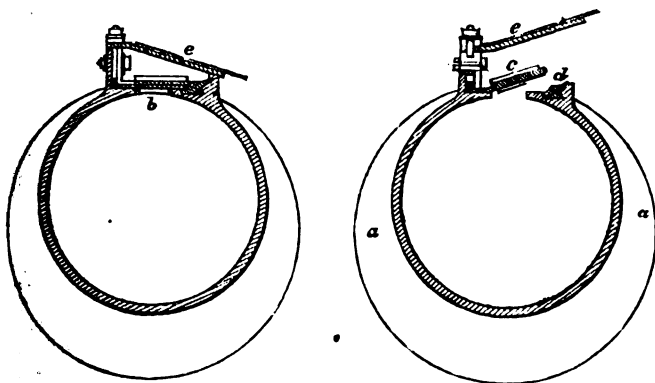


Fig. 2.



above it. After the valve is closed and its extremity is lying in the trough, the tallow is heated sufficiently to seal up or cement together the fracture round the edge of the valve, which the previous opening of the valve had caused, and then the heat being removed the tallow again becomes hard, and forms an air tight joint or cement between the extremity of the valve and the trough. When it is requisite to open the valve, it is done by lifting it out of the tallow, with or without the application of heat, and the before named process of sealing it or rendering it air tight is repeated every time it is closed. This combination of valves with machinery is made in the application of these valves to railways, or other purposes of obtaining a direct tractive force, to move weights either on the railway or otherwise. This I effect by laying down a continuous length of pipe, containing a lateral slit or opening its whole length: a piston is made to travel in this pipe by exhausting or drawing out the air from the pipe on one side of the piston, and allowing free access to the atmosphere on the other side of it; an arm from this piston passes through the lateral opening, to attach to the carriages on the railway, and draws them along with it. The whole of this lateral opening is covered by the valve before described, and that part of it through which the arm passes is lifted to allow it to pass, and also for the admission of air to the piston by means of an apparatus connected to the arm. The carriage to which this arm is attached we call the driving carriage; to the hinder part of this carriage a long heater is attached, which is drawn along by it upon the tallow contained in the trough, and reseals the valve ready for the next train, which repeats the operation above described. At certain distances, which are regulated by the nature of the road, steam engines and air pumps or other apparatus are fixed, for exhausting the pipes, and at a short distance beyond the connexion from the engine to the pipe valves are placed, closing the end of one length or section of pipe and the beginning of the next, between which a space is left for stopping the trains if required; these valves also divide the pipe into suitable lengths, to be exhausted by each apparatus, or close to the end where it is not required to be continued, as on acclivities where the carriages will run by their own gravity; thus every section of pipe is enclosed at the two ends by these valves, and is exhausted by its own steam-engine and apparatus. These valves, which I call the separating valves, are opened by the driving carriage, to allow the piston to pass, and are closed after the train has passed."

*Figs. 1 and 2 represent the construction of the valve, Fig. 1 showing a section of the valve when closed, and Fig. 2 a section of the valve when open;*



*a* is a section of the cast iron vacuum tube or atmospheric main, *b* is the continuous valve of leather extending over the whole length of the opening on the upper side of the tube, and strengthened by short plates of iron *c c*, attached



to the upper and under side of the leather, so as to impart firmness whilst admitting a sufficient degree of flexibility.  $d$  is the composition by which the edge of the valve is hermetically sealed.  $e$  is a protecting cover formed of thin plates of iron about 5 feet long, hinged with leather for protecting the valve from rain, snow, &c; this cover however was, we believe, subsequently dispensed with when the invention was brought into actual operation.

An experimental line of railway was subsequently laid down at Wormwood Scrubbs, by Mr. Clegg and Mr. Samuda, who had an interest in the patent. The length of the line was about half a mile long, with a rise of 1 in 120 for about half the way, and 1 in 115 for the remainder; the diameter of the atmospheric main was 9 inches, and the exhaustion was produced by means of an air pump, of 37 inches in diameter, and 22 inches stroke, worked by a condensing engine of 16 horse power. On this line several public experiments were made, which were attended by many engineers, and other scientific persons, some of whom formed a highly favourable opinion of the plan, and the Dublin and Kingstown railway company were induced by the report of their engineer, Mr. Vignoles, to adopt it in the extension of their line from the terminus at Kingstown to the village of Dalkey.

The length of this line is 3,050 yards, or nearly 1 mile and  $\frac{1}{2}$ , with a rise of  $71\frac{1}{2}$  feet from the commencement at Kingstown to the termination at Dalkey, the average rise from the lowest point being 1 in 140, but the last 365 yards have a rise of 1 in 57; there are also several sharp curves on the line, so that upon the whole it was well adapted to show the capabilities of the system for overcoming steep ascents, and sharp curves. The line is worked only one way by the atmospheric apparatus, the return being effected by the force of gravity.

As stated above, the length of the line is 3,050 yards, but the atmospheric main is only 2,490 yards long, the remainder of the way, 560 yards, being run by the momentum previously acquired. The diameter of the main is 15 inches, and near its extremity branches out a pipe of the same diameter, which leads to the exhausting apparatus, distant nearly 500 yards. The air pump, which is double acting, is  $66\frac{1}{2}$  inches diameter, with a stroke of 66 inches. It is worked by a high pressure condensing engine, of  $34\frac{1}{2}$  inches, and 66 inches stroke, working expansively, the cut off valve being regulated by a governor, so as to vary with the speed of the engine, from  $\frac{1}{2}$  at the slowest to  $\frac{3}{4}$  at the quickest. Mr. Samuda reckons this engine to be of 100 horse power, but it appears that he assumes the horse power to be equal to 66,000lbs, raised one foot high, per minute; other engineers, calculating by Bolton and Watt's standard, estimate that on an average it works up to 180 horse power.

At the entrance end, and some 30 feet from it, is a kind of balance valve. (corresponding to Pinkus's vertical sliding valve,) very ingeniously contrived to open by the pressure of the compressed air in front of the piston; and at the other or exit end is another valve, opening outwards by means of the compression of the rarefied air, after the piston has passed the tube leading from the main to the air pump.

The continuous valve which covers the slit on the surface, is composed of a strip of oxhide of the best quality, strengthened above and below by iron plates, and the leather is double in the part which closes the opening. This valve is fastened down by one edge, (as described in the extract from Mr. Clegg's specification,) and when down fits closely over the slit, its edge being covered by a composition of wax and tallow. From near the centre of the leading carriage descends an arm, which passes through the aperture of the main to the middle of the piston rod within the main. Before the point where this arm is connected to the piston rod are two rollers, (the foremost of which is smaller than the other,) for the purpose of raising the valve, and behind the arm are two similar rollers, for the purpose of keeping open the valve at that part, and thus admitting the atmosphere to press on the back of the piston. After the arm and wheels have passed, the valve drops by its own gravity, and is forced down close by a wheel at the end of the first carriage passing over it: a heater filled with red-hot charcoal was attached to a second carriage, for the purpose of melting the composition, but we believe has since been laid

aside, as unnecessary or ineffective. The advance of the train as it approaches the station is retarded and finally arrested by means of a very powerful brake; it may likewise be arrested on any part of the line, without stopping the engine, by means of a valve in the piston, connected to a lever attached to the leading carriage, by opening which valve the vacuum in front of the piston is destroyed, and the air before and behind the piston is in equilibrio.

Shortly after the Dalkey line came into operation, the French government deputed a Mons. Mallet to examine and report upon the operation of the system as developed on that line. A translation of his report was subsequently published, from which we select the following extracts, showing the results obtained by M. Mallet in his experiments.

"In the following experiments the velocity has been quoted with great care. At each division of the road, forming lengths of 44 yards (40m. 22.) as I have before stated, the time has been marked by means of an instrument in the form of a watch, from which by touching a spring a drop of ink falls upon paper prepared to receive it. This paper takes of course a regular rotatory motion. From the time thus obtained the velocity is calculated. In my notes are the velocities of several trains calculated per hour, for each division, and in order to present their results in the most comprehensible form, I have arranged them in quarters of miles, and in this manner formed the following table.

EXPERIMENTS ON THE WEIGHT AND VELOCITY OF TRAINS.						
Weight of the Trains, English Weight.	SPEED PER HOUR, EXPRESSED IN MILES, Corresponding to the					
	First Quarter of a Mile.	Second Quarter of a Mile.	Third Quarter of a Mile.	Fourth Quarter of a Mile.	Fifth Quarter of a Mile.	Sixth Quarter of a Mile.
Tons.	Miles.	Miles.	Miles.	Miles.	Miles.	Miles.
30	18 . 85	26 . 59	26 . 47	27 . 82	32 . 13	32 . 62
30	17 . 95	25 . 56	26 . 47	25 . 10	28 . 30	30 . 97
38	18 . 10	32 . 20	28 . 96	32 . 20	30 . 00	28 . 96
70	13 . 37	17 . 25	19 . 71	19 . 28	21 . 37	20 . 95
VELOCITIES AT THE DESCENT PRODUCED BY GRAVITY.						
30	13 . 69	20 . 27	22 . 24	20 . 56	21 . 20	21 . 00

"This table only comprehends six quarters of a mile, or 2413m. 50; the total length of the line being 2787. 70, there remain 374 metres, the velocities of which are not reckoned in the table. These 374m. are at the terminus of the line.

EXPERIMENTS ON THE WEIGHT AND SPEED OF TRAINS.							
Weight of the Trains. English Weight.	SPEED PER HOUR, EXPRESSED IN MILES, Corresponding to the						OBSERVATIONS.
	First Quarter of a Mile.	Second Quarter of a Mile.	Third Quarter of a Mile.	Fourth Quarter of a Mile.	Fifth Quarter of a Mile.	Sixth Quarter of a Mile.	
Tons.	Miles.	Miles.	Miles.	Miles.	Miles.	Miles.	Weight of the Train.
60 . 40	12	20	22	21 . 5	21 . 5	21	Tons. 7 Passenger Wagons.....25 . 17 5 Wagons for Goods.....27 . 10 Iron in Chains ..... 5 . 03 47 Passengers ..... 3 . 10 <hr/> 60 . 40
70 . 40	11 . 25	18	19	17 . 6	18 . 4	16	Wagons as above .....52 . 27 Iron in Chains .....10 . 03 121 Passengers ..... 8 . 10 <hr/> 70 . 40
71 . 40	12 . 00	17	18	15 . 5	16 . 6	12 . 5	Wagons as above .....52 . 27 Iron .....10 . 03 134 Passengers ..... 9 . 10 <hr/> 71 . 40

“ These last experiments give us information on some points not previously noticed ; viz. the height of the mercury in the barometer during the course of the train. For the first it stood at  $24\frac{3}{4}$  inches at starting, and at  $23\frac{1}{4}$  at the end of the journey : the second, after having sunk from  $24\frac{3}{4}$  to  $24\frac{1}{4}$  it rose to  $24\frac{3}{4}$  : the third, it sunk from  $24\frac{3}{4}$  to 24 inches, and returned to its former level. In each of these experiments the resistance throughout the course was within a little on an equilibrium with the power.

*Conflicting Opinions on the merits of the Atmospheric System.*—The experience of the atmospheric system on the Dalkey line has called forth the most opposite opinions on its merits from engineers and other scientific characters ; some asserting that the superiority of the atmospheric over the locomotive system is clearly established by the results obtained, whilst others maintain that these results prove not merely that it is inferior to the locomotive system, but that it is utterly inapplicable in the generality of situations and circumstances in which railways are called for. Amongst those who have formed a favourable opinion of the scheme, we may mention Mr. Vignoles, the engineer to the Dublin and Kingstown railway, at whose recommendation the trial of the system on the Dalkey line was made, and who has since decided upon adopting it on a line from Vienna to Schonbrunn. This line, however, is to be a double line, thereby obviating some of the objections raised against the system on the score of the difficulty of working the lines with regularity and punctuality—but at the same time annulling most of the advantages claimed for the system in point of economy of construction and of working. Mr. Brunel has not only expressed a decidedly favourable opinion of the system, but has adopted it on a line now constructing by him (the South Devon, if we recollect rightly). Mr. Cubitt, although expressing a more qualified opinion, has deemed the plan worthy of trial on a portion of the Croydon line, in contemplation of its

further application on the line from Croydon to Epsom; and an atmospheric line is in progress from the latter place to Portsmouth. The French Government (in consequence we believe of M. Mallet's report) have likewise shown that they entertain a favourable opinion of the plan, by ordering it to be applied on a short line from Arras.

On the adverse side of the question are ranged amongst others the names of Mr. R. Stephenson, Mr. Bidder, Mr. Nicholson, and Mr. Herapath.

*Stephenson's Report.*—Mr. R. Stephenson, in a most able and impartial report on the Atmospheric railway, addressed to the directors of the Chester and Holyhead railway, comes to conclusions extremely unfavourable to the invention. Mr. Stephenson's views are founded entirely upon experiments made by himself and his assistants; which are so fully and clearly detailed in the report, and their bearing so clearly but temperately stated, that we regret that our limits will not admit of our giving more than a summary of this valuable document.

The first subject treated of in the report is the amount of leakage. To determine this amount for each part of the apparatus separately when at rest, the engine was stopped after a certain amount of exhaustion had been effected, and the rate at which the mercury in the barometer fell was noted, repeating the process with various lengths of the vacuum tube, and with the pump and connecting pipe alone. These experiments show that the amount of leakage per minute may be taken as uniform, and the average of a considerable number of them gives the leakage, at the density of the external air, as 219 cubic feet per minute for the connecting pipe and air pump, and 252 feet per minute for the vacuum tube, or 186 cubic feet per minute for a mile in length. The report then goes on to observe,—“but it is evident that all leakage must be introduced into the vacuum tube, not at the density of the external atmosphere, but expanded according to the degree of rarefaction of the air in the tube; and hence the effect of this constant amount of leakage upon the velocity of the piston in the vacuum tube will be various at the different heights of the barometer. For example, at Kingstown the leakage of the connecting pipe and pump is 219 cubic feet per minute, and that of the vacuum tube 252 cubic feet per minute; or, 471 cubic feet of air at the density of the atmosphere is introduced into the vacuum tube in each minute: but if the height of the barometer in the tube be 15 inches, or the air twice rarefied, the effect of this leakage will be doubled, and the quantity of air to be extracted from the tube in each minute will be increased by 942 cubic feet; and if the air in the tube be five times rarefied, or the barometer stand at 24 inches, it will be increased by 2,355 cubic feet, instead of 471 cubic feet, in each case. As the degree of exhaustion advances, the retarding influence of the leakage upon the speed becomes more and more serious; for while the velocity of the air pump piston remains constant, or very nearly so, and the cubic extent of each stroke is the same whatever the density of air, the effect of the leakage is increased with the rarefaction, and the maximum velocity attainable by the train is proportionably lowered.”

Previously to calculating the effect of these conditions upon the velocity, the report details, in a table of great extent, the experiments made to ascertain the practical velocities under different circumstances. We have arranged Mr. Stephenson's summary of the results in Table A.

Mr. Stephenson then proceeds to calculate the effect of the leakage (as ascertained with the apparatus in a state of rest) upon the theoretic velocity, computed from the velocity of the air pump piston, and the ratio between its area and the area of the piston in the vacuum tube; and the calculation shows a loss upon the theoretic velocity of from 7 to 30 per cent. in the apparatus at Kingstown, and from 12 to 48 per cent. with a vacuum tube of 4 miles in length; the loss varying as the pressure is increased from 3 to 12·2 lbs per inch. But a considerable difference is also found between the practical velocity and this last calculated, showing a further loss of velocity, increasing from 26 to 41 per cent. between the pressures of 9 and 12·2 lbs per inch, making a total loss on the theoretical velocity between these pressures varying from 39 to 71 per cent.



TABLE A.

No. of Train.	Weight of Train.	Vacuum at Starting.	Highest Vacuum.	Highest Velocity.
	Tons.	Inches.	Inches.	Miles per hour.
1	23.2	8.3	13.7	30.0
2	24.7	8.0	16.7	35.0
3	25.0	9.7	17.5	35.0
4	26.5	8.7	18.5	34.7
5	30.8	8.5	19.0	32.0
6	31.3	11.5	19.1	32.1
*7	34.7	18.0	20.0	29.0
8	36.8	10.7	20.7	28.3
†9	38.3	5.2	21.0	28.3
10	42.5	8.6	22.1	25.7

\* This high vacuum at starting was obtained by holding on the brakes.  
† This Train started with this vacuum owing to a portion of the train standing on the downward incline.  
The weight of the ten following trains increased gradually to 64.7 tons, and the height of the barometer to 24.4 inches.

This difference between the calculated velocity and that obtained in practice shows that the amount of leakage is greater when the apparatus is in motion; part of which Mr. Stephenson supposes to arise at the air pump and at the tube piston.

Upon the subject of the weight drawn, friction, maximum velocity, &c., the author gives the following table, (B.)

In this table those trains are selected from the twenty experiments before mentioned which present the most uniform and valuable results: the data for calculation are given in the first 7 columns; the 8th column gives the total power of the air pump during the whole time the engine was in motion. In each experiment the mean resistance to the air pump piston is multiplied into the velocity of the air pump piston, and is increased in the proportion between the total time the air piston was in motion, and the time required for a train over the entire distance, at its maximum uniform velocity. The power indicated by the air pump during the motion of the train, as shown in the 9th column, is found by multiplying the total resistance to the air pump piston due to the maximum uniform vacuum into the velocity of the piston, and subtracting the product from the total power of working the air pump (column 8), the remainder shows the power absorbed in attaining the vacuum, as given in column 10. Column 11 gives the amount of power absorbed by the train at its maximum uniform velocity on the ascent of 1 in 115; and column 13 gives the power indicated by the friction and gravity of the train, multiplied into the maximum uniform velocity. It will be observed that this power is in every case less than that indicated by the maximum velocity of the train; and the difference between the two, enormous as it is at the higher velocities, Mr. Stephenson considers must be ascribed to the resistance of the atmosphere; and it is accordingly placed under that head in column 14.

In connexion with this part of the subject Mr. Stephenson observes, "In referring to this column representing the loss of power from the resistance of the atmosphere, it will be observed there is a very rapid reduction in the loss as the speed is diminished; indicating most satisfactorily the excessive expenditure of power, and consequent augmentation of expense, in working at high velocities upon railways." This remark is of course equally applicable to all railways, whatever may be the motive power employed, and it is here introduced only for the purpose of showing, that the attainment of speed exceeding that which is now reached upon some of the existing lines of railway, is a matter of extreme difficulty, and that the atmospheric system is not exempt from that

TABLE B.—LOSS OF POWER WITH DIFFERENT WEIGHTS OF TRAIN.

No.	Tons.	lbs.	Miles per hour.	Inches.	lbs per square inch.	Square Inches.	Horse-power.	Horse-power.	Horse-power.	Per Centage of Total.	Horse-power.	Horse-power.	Per Centage of Total.	Horse-power.	Horse-power.	Per Centage of Total.
4	26.5	781	34.7	18.5	9.2	176.7	322	176	146	45	150	172	53	72	78	24
5	30.8	907	32.0	19.0	9.5	176.7	336	181	155	46	148	193	57	77	66	20
7	34.7	1023	29.0	20.0	10.0	176.7	454	184	270	59	137	317	69	79	58	13
8	36.8	1084	28.3	20.7	10.4	176.7	350	186	164	47	139	211	60	82	57	16
9	38.3	1120	28.8	21.0	10.5	176.7	381	186	195	51	140	241	63	85	55	14
10	42.5	1253	25.7	22.1	11.0	176.7	359	184	205	53	133	256	66	86	47	12
11	43.8	1292	25.8	22.5	11.2	176.7	386	181	205	53	133	253	65	87	46	12
12	45.5	1341	25.2	22.7	11.3	176.7	427	181	246	58	134	293	69	87	44	10
14	51.0	1503	22.7	23.3	11.6	176.7	396	173	223	58	124	272	68	90	44	10
15	53.5	1576	21.7	24.0	12.0	176.7	460	170	290	63	123	337	73	91	33	9
17	58.0	1709	20.4	23.8	11.9	176.7	506	170	336	66	114	392	77	93	32	8
18	59.8	1763	18.0	23.6	11.8	176.7	390	170	220	56	100	290	74	93	21	7
20	64.7	1707	16.7	24.4	12.2	176.7	415	162	258	61	96	319	77	85	15	4
																8

NO. OF COLUMN.

1

2

3

4

5

6

7

8

9

10

11

12

13

14

wasteful application of power which high velocities inevitably entail. We have in the experiment No. 4, the effective application of a power of 150 horses, of which 78 horse power, or upwards of 50 per cent., is absorbed by the resistance of the atmosphere at a velocity of about 35 miles per hour.

We would call the reader's attention to the power absorbed in obtaining a vacuum, as ascertained by a comparison of column 8 with column 9, and set forth in column 10. Mr. Stephenson observes, "It may not be at first clearly understood why the power of this column (8) exceeds so greatly that given in the next (9), which is the actual power required to work the air pump; but this will be apparent when it is remembered, that the positive power has been here increased in the proportion of the total time the air pump was at work to the time required for the train to pass over the entire distance at its maximum velocity, which increase has been made in order that a direct comparison may be instituted between this total power and the power required for each of the various resistances of the train." We think this point has not been sufficiently kept in view when the power required in the atmospheric railway has been in question, and that, if not a fatal, it is at least a formidable objection to the atmospheric system under any arrangement, and that it goes far to neutralize one advantage claimed for the system,—that the dead weight of the engine and tender is got rid of. To illustrate this, let it be supposed that the vacuum in the main is produced, not by a pump worked by a stationary engine, but by a travelling piston in the tube, connected to a locomotive engine, the train being connected to another piston detached from the former; and that the distance between the pistons at starting is equal to the length of a section of the tube—say 2 miles: then, if the resistance of the train be equivalent to a pressure of 15 inches of mercury on the area of the piston, or, in other words, if the air in the tube be rarefied to half the density of the atmosphere, it is clear that the locomotive piston must travel two miles before the train begins to move; and if we suppose the engine to be provided with means of cutting off the steam, so as always to proportion it exactly to the resistance, still the power employed in producing the vacuum requisite to set the train in motion will be nearly that required to propel the train half the length of the section, or to propel half the load of the train the whole length of the section. If the resistance of the train required the air in the tube to be rarefied to one fourth of the density of the atmosphere, equal to a pressure of  $22\frac{1}{2}$  inches of mercury, the locomotive would have to travel over six miles ere the train would begin to move, and the power thus expended would be equal to that required for propelling the entire train three-fourths of the length of the section, or to propelling three-fourths of the train the entire length of the section: in other words, the effect is the same as if an addition had been made to the dead weight of the train, equal in the first supposed case to half, and in the second to three-fourths of the weight of the train. Now, by referring to the table it will be seen that the 18th train, weighing 59·8 tons, required a vacuum in the tube equal to 23·6 inches of mercury; the power lost, therefore, in this case, will be equivalent to an addition of a dead weight to the train of more than three-fourths of the whole weight, or more than 45 tons. But the weight of the largest engine with its tender on the Great Western railway we believe does not exceed 26 tons, and it is stated that one of these engines would take 156 tons of gross load at 45 miles per hour; in this instance, therefore, the dead weight of the locomotive is only about five-ninths of that of the atmospheric, and constitutes only one-sixth of the gross load; whereas, on the atmospheric line, it is equal to three-sevenths of the gross load. In the above calculation no account has been taken of leakage, which would of course increase the amount of power lost.

Having given the results obtained on the Dalkey line, Mr. Stephenson proceeds to draw a comparison between the working of the Atmospheric and the other systems. As an example of fixed engines with ropes, he selects the incline on the Birmingham line, between Camden Town and Euston Square, because it presents a case which is similar to that at Kingstown; or, at all events, the disparities are not such as will materially interfere with the comparison. The following table exhibits the results of experiments upon this incline, with

the calculations founded thereon; observing that the friction of the several trains is taken (as on the Dalkey line) at 10 lbs per ton, added to the gravity due to the average gradient.

TRAIN.			POWER ABSORBED BY						
Weight.	Friction.	Gravity.	Friction and Gravity of Rope.	Friction and Gravity of Train.	Resistance of Atmosphere.		Train, excluding Engine and Rope.	Total, excluding Engine.	Power lost by Rope.
Tons.	lbs.	lbs.	lbs per Ton of Train.	Horse-power.	Horse-power.	lbs per Ton of Train.	Horse-power.	Horse-power.	Per Centage of Total.
35	350	740	24.1	58	13	7.0	71	116	39
40	400	845	21.1	67	15	7.0	82	127	36
45	450	951	18.7	75	17	7.0	92	137	33
50	500	1057	16.8	83	19	7.0	102	147	30
70	700	1479	12.0	116	24	6.5	140	185	25
90	900	1902	9.3	149	29	6.0	178	223	20
110	1100	2324	7.7	183	32	5.5	215	260	17

*Constants.*—Average gradient 1 in 106; length worked by rope .91 miles; weight of rope 7 tons; area of both cylinders 2904 square inches; velocity of pistons 224 feet per minute; mean pressure on piston 2.9 lbs and 3.0 lbs per square inch; friction of engine 13 H. P.; friction and gravity of rope 45 H. P.; velocity of train 20 miles per hour; friction and gravity of train 31.1 lbs per ton of train.

Mr. Stephenson then compares the fourth train in the last table with the eighteenth train in the preceding table, being two cases which present the closest analogy in the amount of their resistances and velocity. The loss of power from working the rope, as shown in the table, is 30 per cent of the whole; but this must be increased in the proportion of the mean to the maximum velocity, which in this instance is ascertained, from experiments made, to add thirty-seven horse power to the loss, making the total loss by the rope on the Euston incline 45 per cent. whilst on the Dalkey line the loss by the atmospheric apparatus is 74 per cent. This result is obtained with what may be regarded as an average train on the Euston incline; it is evident therefore that in this particular instance the rope is considerably more economical than the Atmospheric system. Assuming other weights of train, as the weight of the train is diminished the proportionate loss by the atmospheric decreases, and the loss by the rope augments; whilst by increasing the weight of the trains the proportionate loss by the atmospheric is augmented, and that by the rope is diminished. Comparing the atmospheric with the locomotive system, Mr. Stephenson admits, with light trains upon steep inclines and at considerable velocities, the atmospheric system (in common with all systems in which stationary engines are employed) may possibly exceed the capabilities of locomotive engines; but that if the loads be converted into equivalent loads on a level, then the locomotives have the advantage. Thus, taking the experiment No. 4 in the table of the Dalkey performances, (which he considers as indis-



putably the most favourable one recorded,) the load was 26·5 tons taken up an incline of 1 in 115 at a speed of 34·7 miles per hour, which he shows to be equivalent to 44 tons upon a level at the same speed of 34·7 miles per hour; but this is much exceeded daily on many lines of railway, and especially by the Great Western, and the Northern and Eastern. On a long series of steep gradients, extending over several miles, and where the nature of the traffic is such that it is essential to avoid intermediate stoppages, the atmospheric system would be most expedient; but if intermediate stoppages are not objectionable, as in the case of the conveyance of heavy goods and mineral trains on the railways in the neighbourhood of Newcastle-upon-Tyne, the application of the rope is preferable to the atmospheric system, as is fully established by the comparison made between the Kingstown and the Euston inclines.

On the questions of expense of construction, and of working a long line of railway, the report is equally unfavourable to the atmospheric system; but upon these points the arguments are necessarily based upon assumptions, as, from the fact of the system not having yet been brought into operation on an extended scale, no reference can be made to experience; and the premises upon which Mr. Stephenson argues are so widely different from those assumed by the advocates of the atmospheric system, that we cannot be surprised at the enormous discrepancy of the conclusions at which they severally arrive.

In computing the cost of construction under the atmospheric system, its supporters always assume that a single line will be sufficient; but this Mr. Stephenson does not admit; on the contrary, he contends that the only means by which the atmospheric system can (if at all) meet the various exigencies of ordinary railway traffic, is to employ a double line of tube: this at once doubles the actual cost of the apparatus, and at the same time disallows those claims to economy of construction, founded upon the smaller quantity of land required, and the diminished size of the bridges and tunnels. We regret that our space will not allow us to give at length the arguments by which Mr. Stephenson supports his opinions, and that we must limit ourselves to his calculations of the comparative cost of the system.

Mr. Samuda, modifying his calculations by his experience on the Dalkey line, gives the following as his estimate of the cost for the apparatus, as applicable to such lines of railway as the London and Birmingham:—

## COST PER MILE IN LENGTH.

Vacuum tube 15 inches diameter . . . . .	£1,632	
Longitudinal valve, &c. . . . .	770	
Composition for lining, and valve groove . . . . .	250	
Planing, drilling, &c. . . . .	295	
Laying, joining, &c. . . . .	295	
Station valves, and piston apparatus . . . . .	100	
		£3,312
Engine, 100 horse power, with pump, &c. . . . .	£4,250	
Engine house, chimney, &c. . . . .	450	
Total for 3½ miles . . . . .	4,700	
Cost per mile in length . . . . .		1,345
		£4,685
	Total cost per mile . . . . .	£4,685

On this Mr. Stephenson remarks, "It will be observed, that Mr. Samuda has only estimated for a single line of vacuum tube, and a single series, under the impression that such an arrangement is adequate to meet every necessity; but from what has been said on this part of the subject, I think it is made evident that such a limitation in the arrangements on any important line of communication would be very inexpedient, to say the least: I have consequently revised this estimate, and the following appears to me to be the minimum

expense at which the atmospheric apparatus could be applied to any extensive line of railway :—

## COST PER MILE IN LENGTH.

Vacuum tube 15 inches diameter . . . . .	£7,000
Two engines, 250 horse power each, at 33,000 lbs, with pumps, &c. complete, at £25 per horse power . . . . .	12,500
Engine house, chimney, reservoir or well . . . . .	1,500
Total for 3½ miles . . . . .	14,000
Cost per mile in length . . . . .	4,000
Total cost per mile . . . . .	<u>£11,000</u>

“ This amount exceeds Mr. Samuda's estimate very considerably, but the cause has been sufficiently explained.

“ The power of the engines that I have assumed may at first appear large, but taking the engine on the Kingstown and Dalkey railway as our guide, it will be found, that the power reckoned upon does not exceed that which would be required to ensure sufficiently high velocities, with only the average passenger trains which now travel on the London and Birmingham railway; and we must bear in mind that the atmospheric system involves the necessity of employing very nearly the same power with light as with heavy trains.

“ The engine at Kingstown may be taken at nearly 200 horse power, and capable of moving a train of about 36 tons, upon a gradient of 16 feet per mile, at 35 miles per hour. If we extend the length of tube to 3½ miles, when the increased leakage is added, the power required to move even such a load (which is below the average load of the London and Birmingham traffic) at this velocity, will be upwards of the 250 horse power, which I have assumed as requisite, and which makes the gross expense £11,000 per mile. \*

“ By referring to the half yearly statements of accounts of the London and Birmingham railway company, it will be seen that the capital invested in locomotive engines up to 31st December, 1843, was £171,974 17s. 6d. For the purpose of arriving at the whole capital actually invested under the head of power, we must add locomotive engine stations for repairing &c.: this item is not separately stated in the account, but we shall be safe in taking it at £150,000, making the total investment for power, £321,974. It must be understood that I am not attempting here to comprise all the sums which might come under this heading, supposing the accounts to be fully dissected, my only object is to make a comparative estimate, which is done correctly enough without introducing such items as would be common to both systems. The comparison of capital expenditure for power upon this basis on the London and Birmingham railway, would stand thus:—

Locomotive engines and stations . . . . .	£321,974
Atmospheric apparatus for 111 miles, at £11,000 per mile . . . . .	1,221,000

making a difference in favour of the locomotive system, as far as capital in power is concerned, of £899,026. This large disparity in the cost of the two descriptions of power might, it is urged, be more than saved by a reduction in the original cost of construction of the railway. This is partially true in the case of the London and Birmingham railway, but not by any means to the extent generally imagined.

“ I cannot now attempt to enter into the minutiae of this part of the subject, because it would involve a complete revision of all the original plans, and numerous considerations which could not now be fairly weighed. For the purpose, however, of carrying out the comparison regarding capital in this

\* Mr. Stephenson takes 33,000lbs as the standard of horse power, but Mr. Samuda takes 66,000; therefore, the engine which Mr. Samuda reckons at 100 horse power, Mr. Stephenson estimates as 200 horse power, so that the actual difference in the estimate of the power required to exhaust the pipe is only as 100 to 125.

particular case, we may suppose that a saving of £900,000 might have been accomplished in the original design, by the application of the atmospheric system, still, it would only have been a transfer of expenditure from excavations, tunnels, and bridges, to steam engines and pipes; the ultimate capital would thus have been the same.

"If we now take some other lines of railway, with the view of ascertaining how far their cost could have been diminished by the application of the atmospheric system, we shall find that as the surface of the country becomes more favourable, the economy in construction entirely disappears, and when we arrive at a perfectly plain country, such as exists in the eastern counties of England, where few provisions are required in the form of excavations, tunnels, and bridges, the application of the atmospheric system would certainly double the original cost where a double line of rails is employed. The Grand Junction railway is a case where no reduction of original outlay could have been effected, since the gradients already conform to the natural surface of the country throughout a very large proportion of the whole line. The adoption of the atmospheric system in this case would therefore have caused a very large augmentation in the capital of the Company, probably as much as £8,000 per mile, being the difference of cost between the two descriptions of power."

Mr. Stephenson next proceeds to give an approximate statement of the cost of working the two systems, excluding such items as are common to both; but he observes, that "while the cost of the locomotive power is taken from the accounts of the company,—the principal items, and only those, which may be taken as certain in the cost of the atmospheric system, are taken into the account in the comparative statement; in the latter, many minor expenses in the absence of experience must unavoidably be omitted; thus giving some advantage in the comparison to the atmospheric system."

"The expense of locomotive power upon the London and Birmingham railway for the year 1843, was as follows:—

Wages of engine drivers and firemen . . . . .	£9,673
Coke . . . . .	25,541
Oil, hose, pipes, and fire tools, pumping engines and water . . . . .	4,099
Labourers and cleaners, waste and oil . . . . .	4,194
Repairs of engines and tenders . . . . .	12,521
Coals and fire-wood, expenses of stationary engine at Wolverton, repairs of buildings, gas, and incidental charges . . . . .	3,172
Superintendent, clerks, and foremen's salaries, and office charges . . . . .	4,634
	<u>£63,834</u>

"The expense of working the atmospheric system for one year, I estimate approximately as follows:—

Wages of engine men . . . . . 64 at 6s. }	£10,512
„ stokers . . . . . 64 at 3s. }	
The same during the night . . . . .	10,512
Coal, 172 tons per day, at 9s. . . . .	28,332
Oil, hemp, tallow, and repairs at 5 per cent. on cost of engines . . . . .	20,000
Superintendence, same as locomotive . . . . .	4,634
	<u>£73,990</u>

This statement, in Mr. Stephenson's opinion, sufficiently establishes the fact that the cost of working the London and Birmingham railway, or any other line with a similar traffic, by the atmospheric system, would greatly exceed that by locomotive engines.

Having concluded his observations upon the question of power, original outlay, and cost of working, the two latter having reference chiefly to the London and Birmingham railway, he proceeds: "I will now offer one brief remark on the application of the atmospheric system to lines where the traffic is of very moderate extent. The London and Birmingham railway having an unparalleled traffic, it is one of the best cases, in a general point of view, to which the atmospheric system could be applied. Let us now conceive it applied to a case of an opposite character—for example, the Norwich and Yarmouth railway, which has cost about £10,000 per mile, including stock and every appurtenance. This line passes over a country in which the application of the atmospheric system could have effected no economy whatever in the formation of the line, which has not exceeded a cost of £8,000 per mile. The application of a single line of the atmospheric apparatus would, in this instance, have added at least £5,000 per mile, which upon 20 miles, the length of the railway, would amount to £100,000. The mere interest of this sum, at 5 per cent., is £5,000 per annum; whereas, the actual working of this line, including maintenance of way, booking offices, portage, and all other constant traffic charges, has been let for £7,000 per annum; being only £2,000 above the bare interest of the extra capital which would be required to lay down the atmospheric apparatus, an amount which would be quite inadequate to meet the wear and tear of the machinery alone, leaving nothing to meet the current cost of working. Here, therefore, we have a case where the country is favourable, the original capital small, and the traffic moderate, where the cost of the atmospheric system would be so burthensome as to render it totally inapplicable."

Mr. Stephenson sums up in the following manner:—

1st. That the atmospheric system is not an economical mode of transmitting power, and is inferior in this respect both to locomotive engines and stationary engines with ropes.

2d. That it is not calculated practically to acquire and maintain higher velocities than are comprised in the present working of locomotive engines.

3d. That it would not, in the majority of instances, produce economy in the original construction of railways, and in many would most materially augment their cost.

4th. That on some short railways, where the traffic is large, admitting of trains of moderate weight, but requiring high velocities and frequent departures, and where the face of the country is such as to preclude the use of gradients suitable for locomotive engines, the atmospheric system would prove the most eligible.

5th. That on short lines of railway, say four or five miles in length, in the vicinity of large towns, where frequent and rapid communication is required between the termini alone, the atmospheric system might be advantageously applied.

6th. That on short lines, such as the Blackwall railway, where the traffic is chiefly derived from intermediate points, requiring frequent stoppages between the termini, the atmospheric system is inapplicable, being much inferior to the plan of disconnecting the carriage from a rope, for the accommodation of the intermediate traffic.

7th. That on long lines of railway, the requisites of a large traffic cannot be attained by so inflexible a system as the atmospheric, in which the efficient operation of the whole depends so completely upon the perfect performance of each individual section of the machinery.

*Herapath's Report.*—Mr. Herapath published a most able and searching analysis of M. Mallet's report; but, from the great length we have already devoted to this part of the subject, we can do little more than notice his observations upon the amount of power expended in relation to the mechanical effect obtained.

He observes that "the relative areas of the air pump, and of the tube, and the number of strokes made by the air pump per minute, being known, we

obtain the length of main that could be exhausted in an hour, which is the rate the load should travel per hour, if there were no loss from leakage. Again, having the exhaustion of the main in inches of the barometer, and the sectional area of the main, we get the tractive power, supposing there was no friction in the main. This tractive power multiplied by the velocity, gives the dynamic effect (or momentum) which the atmospheric railway should have, if there was no leakage or friction of the piston with its gear: hence, comparing this with experiment, we get the waste of power employed, or the expenditure to produce a given effect, independently of knowing the power of the engine.

"We have shown that the air cylinder would extract 73.154 yards of the main at every stroke, consequently, there being 22 strokes a minute, we have

$$\frac{73.154 \times 22 \times 60}{1760} = 54.865 \text{ miles per hour}$$

for the velocity of a train, if there was no leakage at all. Either up hill, or on a level, this velocity should be the same if the apparatus was perfect. Moreover, the sectional area of the main being 176.71 inches, and the pressure of a column of mercury one inch high being 49lbs., we shall have for the pressure of an exhaustion of 24.75 inches—that at which the last experiment (p. 492) was made,— $176.71 \times 49 \times 24.75 = 2143.11\text{lbs.}$  But a ton of goods going up an incline of .00719, gravitates backwards 16.10lbs, and if the road friction of the carriages is 8lbs. per ton, we have 24.11b. for the tractive force to draw one ton up an incline of .00719. Therefore  $\frac{2143.1}{24.1} = 88.923 \text{ tons.}$

Hence, the atmospheric should take 88.923 tons up the Dalkey incline, at the rate of 54.865 miles per hour, but it only takes 71.4 tons at a speed of 15.92 miles an hour. Therefore, what the apparatus does do, is to what it should do, as  $71.4 \times 15.92 : 88.923 \times 54.865 :: 1 : 4.3$ . That is, between friction and leakage, the useful effect is not a fourth of what it ought to be, and this, it will be observed, is on the maximum effect of the plan."

On the subject of the cost of working the line, taking Mr. Bergin's statement, that the expense amounts to £1,171 per annum for the whole line, he observes, that this is equal to £781 per mile, and gives the following comparative view of the cost of motive power on the atmospheric and the locomotive systems.

Great Western locomotive . . . . .	£357
London and Birmingham ditto . . . . .	575
Dalkey Atmospheric . . . . .	781

Again, comparing the working expenses at Dalkey with those of the Camden station, where fixed engines and ropes are employed, he computes the cost of fuel and wages at Dalkey by the same scale as these items are charged at the Camden station, and he makes the cost of the Dalkey line to be £1,950, £1,300 per mile. By the statement of Mr. Creed, the secretary to the London and Birmingham line, it appears that the expenses of the Camden station for the year 1843, amounted to £1,441, and the line being 1 mile 4 chains in length, this is equal to £1,372 per mile.

*Bergin's Evidence.*—Mr. Bergin, the superintendent of the Dalkey line, in his evidence before the Committee of the House of Commons, on the Portsmouth atmospheric line, stated that the average consumption of coal was 37 cwt. per day, and that the expense of working the line was £1,171 per annum, which he distributes as follows:

Coals, engine house and men . . . . .	£900
Piston, continuous valve, and men to attend the same . . . . .	271
	<hr/>
	£1,171

which is equal to £670 per mile per annum. The cost of haulage he calculates to be 10d. per train per mile.

*Pilbrow's Atmospheric Railway.*—Although, as we have shown, the results obtained on the Dalkey line are not universally regarded as in favour of the

atmospheric principle, many eminent engineers contending that they decidedly establish its inferiority to the locomotive system, it is clear, from the many inventions which have since been brought forward in connexion with the subject, that the principle of atmospheric, or at least pneumatic propulsion has numerous partisans, who consider that all that is required to establish its superiority is either new modes of applying the principle, or improvements in the details of execution. From the interest excited by the subject we shall proceed to notice a few of these inventions. We shall commence with Mr. Pilbrow's atmospheric railway, the distinguishing characteristic of which is, that the atmospheric main or tube is closed throughout its length; the connexion between the leading carriage on the rails and the travelling piston inside the tube being effected by a singular and extremely ingenious arrangement. The apparatus consists of a cylindrical cast iron tube, having a covered rectangular channel extending along its upper side. Along this channel, at intervals of about 30 feet, are fixed small square boxes, with standards to each to support a pair of vertical spindles, placed one on each side of the channel. On the lower end of each spindle, within the boxes, and on a level with the channel, is fixed a pinion with oblique teeth, and to the upper side of the travelling piston is attached a bar or rack with similar teeth on each side; the progress of the piston brings the rack between the wheels, and turns the spindles round with great velocity. To the upper ends of the spindles are fixed pinions exactly like those below, and to the leading carriage is attached a rack similar to the piston rack. This upper rack lies immediately over the lower or piston rack, and gears into the upper pinions; the advance of the piston, therefore, by imparting motion to the upper pinions, causes a corresponding advance of the carriage. Each rack is of sufficient length to reach from one pair of pinions to another, and consequently the racks are always in gear with the pinions on one pair of spindles.

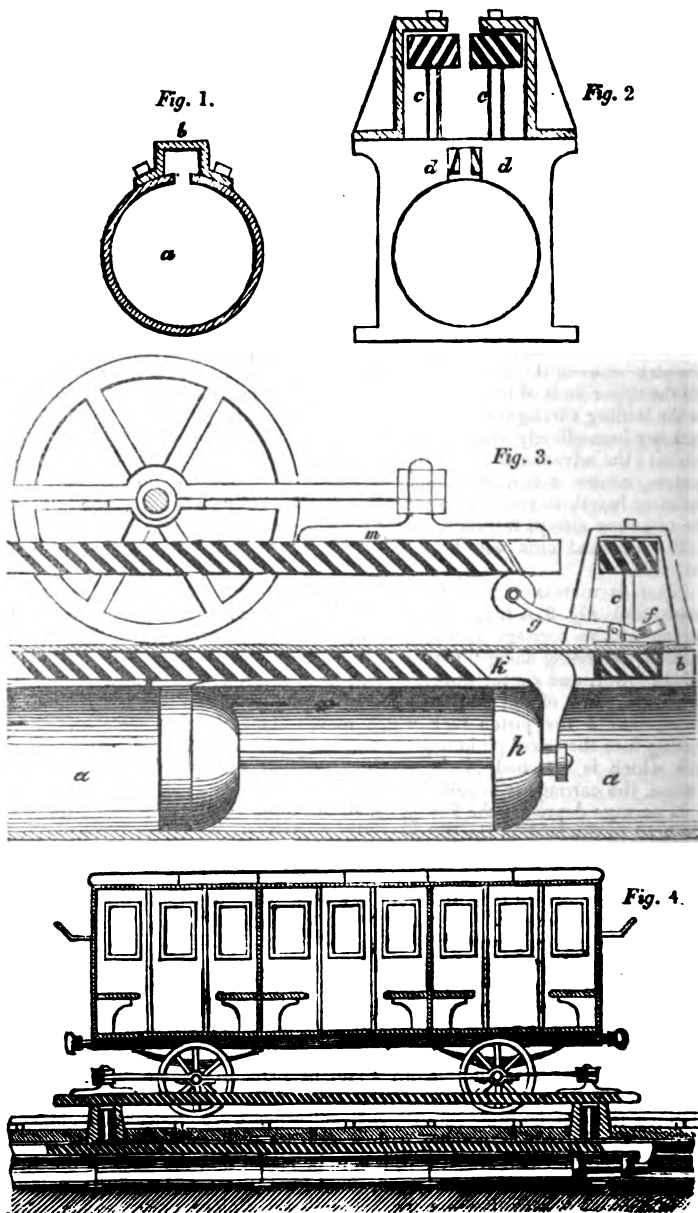
The annexed cuts will help to render the foregoing description more intelligible.

*Fig. 1.* is a cross section of the atmospheric main, *Fig. 2.* a section at the boxes, and *Fig. 3.* a longitudinal section of the main, with the piston and a portion of the carriage racks; *a* is the tube, and *b* the rectangular covered channel extending along the upper side of the tube; *c c* are the spindles, and *d d* the lower, and *e e* the upper, pinions fixed thereon; *f* is a valve to admit the air to the back of the piston, and *g* is the key by which it is raised; *h* is the piston, and *k* the piston rack which moves along the covered channel, and gearing into the lower pinions gives motion to the spindles; *m* is the external rack which is attached to the leading carriage, and gearing into the upper pinions, the carriage is impelled with the same velocity as the piston; this rack in its passage depresses the key *g*, which raises the valve *f*, by which the air is admitted to the back of the piston.

*Fig. 4* is a representation of the leading carriage with the whole of the apparatus.

It cannot be denied that Mr. Pilbrow's arrangements exhibit great ingenuity and skill, but experience is wanting to show how far the system is adapted to meet the various exigences of railway traffic. The point on which failure is most to be apprehended is precisely that on which the whole system depends, viz., the mode of connecting the piston with the train. For the perfect working of the plan each pair of pinions should stand in such position that the teeth of the piston rack shall, on reaching the pinions, fall into the space between two of the pinion teeth, instead of encountering the teeth themselves; should the latter event happen, the rack and pinions would be liable to become jammed, and a fracture of some part of the apparatus must ensue; but even supposing this objection to be of no practical moment, still, when we consider the momentum of a heavy train, which, moving with a velocity of 30 miles, comes in contact with the pinions, which are at rest, it is to be feared that the teeth of the racks and pinions would soon be destroyed, or at least that a series of shocks would take place, as the racks became engaged with the pinions in succession, which would prove highly unpleasant to passengers, and tend to check the velocity and to increase greatly the wear and tear of the carriages. Should these difficulties,

however, prove to be imaginary, or greatly overrated, we think it will be found to possess many of the advantages over the Samuda system which Mr. Pilbrow



has claimed for it in a pamphlet which he has published. Among the least disputable of these advantages are the following:—

1st. As regards facility and economy of construction; public roads may cross the line on a level, whereby bridges are rendered unnecessary; no cranes or elevated rails are required for taking carriages on or off the line, and different lines of railway may cross each other at any required angle, (one tube passing below the other tube,) which on Mr. Samuda's plan cannot be done. Mr. Pilbrow further claims a saving as regards the cost of his main, and also in the difference of expense between the continuous valve and his spindles and pinions, but we think this latter item more doubtful.

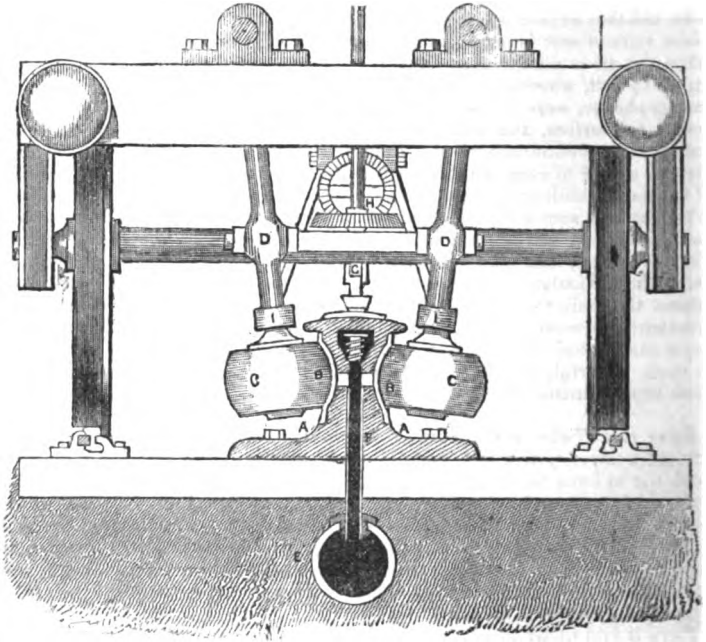
2d. As regards the loss of power from leakage; the piston valves are less liable to leak than the continuous valves, as the former are ground into their seats, and they expose a less surface at which leakage can take place; for the pinion valve or seat is but about nine inches in circumference at the aperture where the air is admitted, and there are but two of them to every 30 feet of main= $1\frac{1}{2}$  feet, whereas in the continuous valve the whole 30 feet is liable to leakage; hence, were the piston valves even to leak as much as the long valve, surface for surface, the leakage would amount to only one-twentieth of the leakage of the continuous valve. From this circumstance Mr. Pilbrow assumes that one engine to every 10 miles will be found sufficient, whereby the number of engine establishments upon a line would be greatly reduced: but leakage is not the only source of loss of power in the atmospheric tube; the resistance from the friction of the air in the tube is very considerable, increasing rapidly with the length, and Mr. Herapath, from M. Mallet's experiments on the Dalkey line, calculates that with a main  $5\frac{1}{2}$  miles long, the engine could not exhaust the main to one half of that which it would if only  $1\frac{1}{2}$  mile long; and he contends, therefore, that nothing is gained in applying this system by employing longer mains than  $1\frac{1}{2}$  mile, and is of opinion that mains of only a mile would be more powerful, command greater loads and velocities, and prove on the whole more economical.

*Keene and Nickels's Pneumatic Railway.*—Messrs. Keene and Nickels have patented a novel system of railway locomotion, which is founded on principles stated not to have been hitherto applied to the communication of mechanical motion. It differs from the atmospheric railway in this respect, that it, is without travelling piston as in Clegg's and Samuda's, and without racks and pinions as in Pilbrow's invention: the carriage is propelled by the pressure of air, with great velocity, and a tractive power is attained superior to that of the working models on the same scale of either of the atmospheric railways. The following are the main details.

There is laid under ground an air-tight chamber, or cast iron pipe, which contains the moving power, air condensed by forcing pumps to about three atmospheres: that is, the air in this chamber is compressed into one third of its volume under ordinary atmospheric pressure. Midway between the rails are laid longitudinally, at certain intervals, standing above the surface, squared beams of wood, or iron, say from twenty to thirty feet in length: the two vertical sides of the beam are a little hollowed, and along these channels on each side is placed a tube of an elastic air tight material, susceptible of easy expansion and collapse. The expansible tubes communicate by intermediate pipes, furnished with stop-cocks, with the reservoir of compressed air. Such are the fixtures of the apparatus. Then, on the under side of the carriage to be moved are two solid drums, fixed on vertical spindles, which run in supporting collars, and these drums are so placed, that when the carriage moving on its independent wheels upon the rails, passes over the horizontal beams, they embrace the two vertical sides, and closely compress the lateral elastic tubes, so as to leave no air passage beyond the point of contact. Now imagine the carriage thus equipped to be stationary over that which we will call the interior extremity of one of the beams, from which point motion is to begin. A stop-cock in the connecting tube is opened, and instantaneously a portion of the compressed air from the reservoir rushes by its expansive force into the two lateral flexible tubes, and meeting resistance on the line of compression of the two drums, it drives them, and consequently the carriage,



forward, following them with the same propulsive energy to the other extremity of the beam. By this action the carriage has acquired such a momentum, as to carry it with the velocity required, onwards to the next beam, where the impulse is renewed, and thus repeated through the whole length of the line. This is a brief description of the *modus agendi* of the system, which will enable the general reader to comprehend in what manner compressed air with an acting pressure of forty pounds to the square inch, admitted through a pipe not more than  $1\frac{1}{2}$  inch in diameter, propels a carriage holding four persons with great velocity.



THE CUT REPRESENTS A TRANSVERSE SECTION OF THE APPARATUS.

A A, Iron Flange forming the inside of the valves; n n, Diaphragms composed of leather-canvas and Gutta percha, forming outsides of valves; c c, Pinions turning on axles D D; x, Main pipe containing compressed air; y, Spring tube for admitting the compressed air from the main pipe x to the interior of the valves; e, Skate for depressing the spring tube; z z, Gear for raising or depressing skate; I I, Rods for supporting pinions.

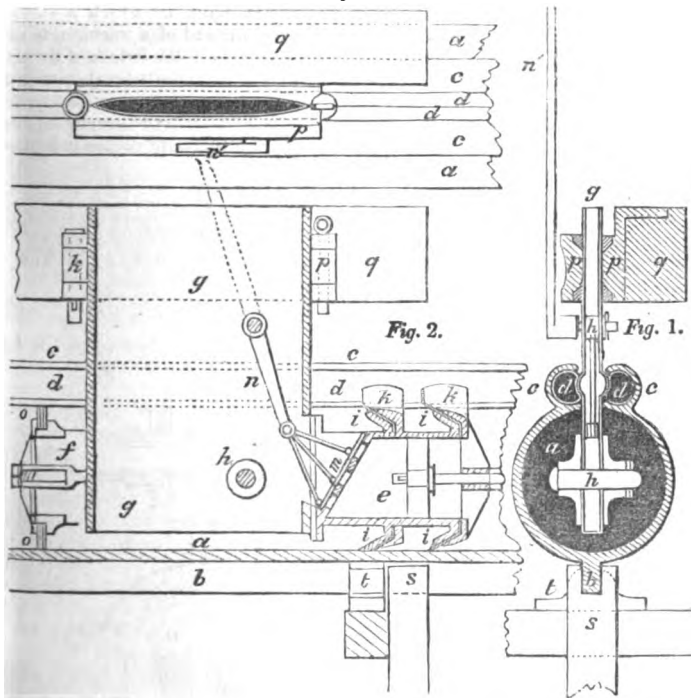
The Gutta percha above mentioned is a gum lately introduced from Singapore. it possesses properties which render it superior to caoutchouc; it is uninjured by heat or acids, is elastic, but possesses more tenacity; and at  $212^{\circ}$  Fahrenheit can be moulded into any form, or two pieces can be kneaded together with the fingers, and the joint made as strong as the original substance.

*Hallett's Atmospheric Railway.*—We shall now briefly describe what has been generally termed "Hallett's system of atmospheric railway;" although, strictly speaking, the system is not new, being in fact a combination of Mr. Pinkus's two plans, and the improvements consisting of modifications of different parts of the apparatus, chiefly the continuous valve, the piston, and the mode of connecting a pneumatic locomotive engine with the pneumatic main, as proposed by Mr. Pinkus in his patent of 1836. Mr. Hallett's improvements form the subjects of two patents in this country, which were taken in the name of Mr. W. Newton. In his first patent Mr. Hallett employs a piston, travel-

ling in the air tube as proposed in Mr. Pinkus's first plan; but the longitudinal valve is on the principle of that proposed in Mr. Pinkus's second plan, already described, in which the slit is closed by two elastic plates of metal, extending the length of the tube; these plates in Mr. Hallette's plan being replaced by flexible hose, filled with air or water, or a portion of both.

Fig. 1 represents a transverse section of the tube, and of the arm by which the piston is connected with the leading carriage of the train; fig. 2 is a longitudinal section of the tube and piston; and fig. 3 is a plan of the tube and of the piston arm. *a* is the tube, having a slit or opening for the passage of the

Fig. 3.

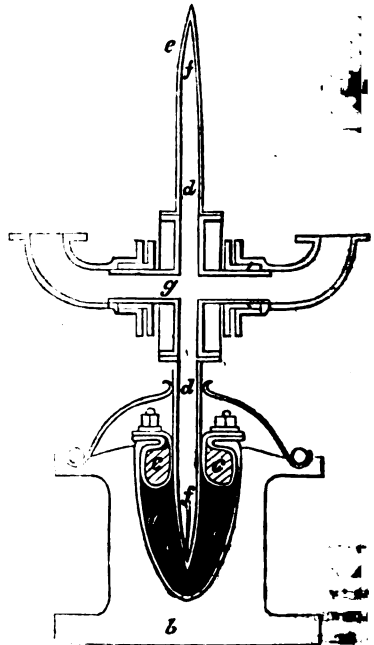


piston arm, extending along its upper side, and strengthened below by a rib, *b*. Along each side of the slit extends a semicircular trough or recess *c c*, cast upon the tube, and in each recess is lodged an air tight flexible tube or hose *d d*, filled with compressed air, and any suitable liquid; and the two hose lying in close contact with each other close hermetically the longitudinal slit. The travelling piston is composed of a short tube *e*, attached to a forked lever *f*, which receives within its fork the hollow arm *g*, and is jointed thereto by the pin *h*. The piston carries at its circumference two cupped leathers secured by rings at *i i*, to form an air tight joint with the interior of the atmospheric main, and two pieces of brass at *k k*, which fill up the breadth of the slit, and prevent the passage of the air at that part into the vacuum in front of the piston. The piston is open at the fore end, but at the back it is closed by hinge valves *m m*, which are connected by rods to the lever *n n* (within the hollow arm), by means of which they can be raised when it is requisite to destroy the vacuum, in order to prevent the advance of the train. The piston is free to turn upon the pin *h*, being counterbalanced by the weight of the lever *f*, and the latter has several collars of stout leather, screwed up between two rings at *o o*, to deaden the

concussions which might arise from any irregularities in the level of the *main*. The hollow arm *g*, is made of wrought iron, and in its horizontal section has the form of a weaver's shuttle, as is shown in the plan. This arm is connected to the leading carriage by a hinged clamp *p*, attached to a stout bar of wood *q*, secured to the under side of the frame of the carriage. The atmospheric tube is not attached to the transverse sleepers which carry the rails, but is supported upon a number of vertical posts *s*, driven into the ground midway between the rails, and having a notch in the upper end to receive the rib of the tube, and it is steadied laterally by chairs *t*, bolted to the sleepers.

Mr. Hallette's second plan resembles in principle that of Mr. Pinkus, in which a pneumatic locomotive was substituted for a steam locomotive, the pneumatic engines communicating with the pneumatic main, in which a vacuum was to be maintained; but Mr. Hallette proposes, instead of a vacuum, to employ compressed air. Mr. Hallette's chief improvements in the details of the plan consist, firstly, in the valve or apparatus for closing the longitudinal opening in the tube; and secondly, an apparatus whereby the locomotives may be supplied with compressed air, without creating too much friction, and thereby injuring those parts of the longitudinal valve with which the instrument comes in contact.

The accompanying figure represents a transverse section of the pneumatic tube, and the connecting apparatus *a*, is the pneumatic tube, formed of sheet iron, and supported by chairs *b*. The longitudinal groove is closed by means of two long cushions, *c*, the surfaces of which, when at rest, are by their own elasticity maintained in close contact with each other, and thereby prevent the passage of air between them, except when forced apart for the purpose of allowing the compressed air to enter the locomotive engines. These cushions are made of leather, and filled with a composition of gelatine and molasses, or any other suitable compound; and the edges of the tube are pinched between the doubled-over edge of the tube, and an iron band. *d* is a hollow disc, from 3 to 5 feet in diameter, and in its transverse section resembling a double convex lens. It is mounted on hollow axles *g*, which work in stuffing boxes, attached to the locomotive, and form a communication between the disc and the locomotive engines.

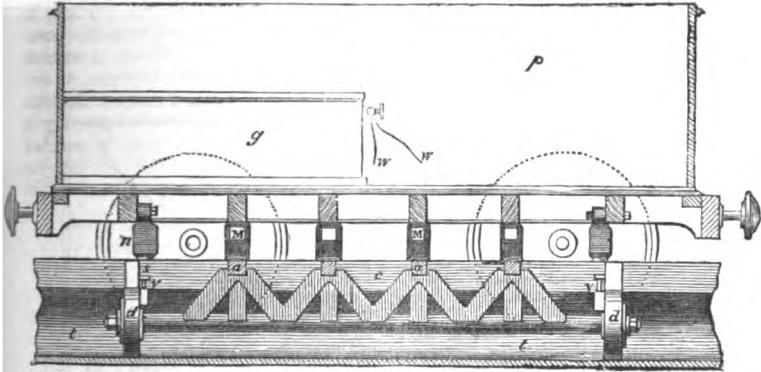


Near the periphery of the disc are a number of small apertures *e*, closed on the inside by valves of soft leather *f*. The tube being filled with compressed air, and the disc being inserted between the cushions, the air will force open the valves *f*, and instantly fill the disk with air of the same density, and as the disk revolves and finally passes out into the atmosphere, the compressed air within the disc closes the valves, *f*, in which it is assisted by a spring. As the engine advances along the rails, the disc revolves between the cushions, which recede as it advances and close upon it behind, so as to preclude the escape of the compressed air within the tube, into the atmosphere; and to reduce the friction between the disc and the cushions, the latter are lubricated with a mixture of suet and powdered talc. The pneumatic tube is divided into sections of about

100 yards long, and at the end of every section, a yard or two, with its cushions, is sloped down to the revolving disc, to enter and leave the tube more gradually.

We conclude our account of the atmospheric modes of propulsion, by a description of *Taylor and Conder's patent electro-magnetic railway*. This invention consists in the application of electro-magnetic power, to connect the piston carriage of a train with the driving piston within the tube. *Fig. 1* is a longitudinal section, and *Fig. 2* a cross section of an atmospheric railway tube,

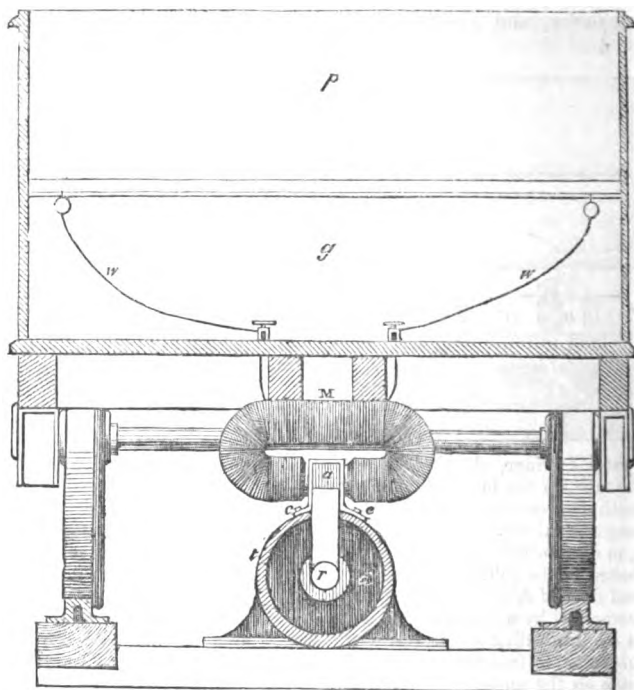
*Fig. 1.*



and piston carriage, showing the manner in which the connexion is effected. *t* is the tube, in the top of which there is a longitudinal slit or opening as usual, but much narrower; *c* is a continuous air tight cover which is bolted down upon the longitudinal slit. The tube *t* is of iron, but the cover *c* is made of copper, brass, or some other substance not susceptible of the electro-magnetic influence, and bolted to the tube by copper bolts; *d* is the driving piston, which consists of two end discs *d d*, of the same diameter as the interior of the tube (or nearly so), connected by a rod *r*, which carries (as here shown) four upright square pieces *a a a a*, called armatures, which project upwards through the top slit in the tube, and fit into the square space within the cover *c*. These armatures are made on the upper part of some substance not susceptible of the electro-magnetic influence, as brass or wood, but capped at the top by pieces of iron, secured by copper bolts. *p* is the piston carriage, to the bottom of which there is attached (instead of the usual piston connecting rod) four electro-magnets *m m m m* of the peculiar form shown in *Fig. 2*, each of which presents its two extremities or poles to the sides of the cover *c*. The power of the magnets may be increased by inclosing them in a tube or case of iron, leaving the extremities or poles open. *g* is a galvanic battery placed in the piston carriage, and which may be of any approved form and of any required power; *w w* are wires by which the battery is connected with the electro-magnets *m m m m*. The mode of action is as follows. Motion being given to the piston by exhaustion (more or less) from the tube of the air in front of the piston, and the magnets being at the same time connected with and excited by the battery, the magnets act by induction on the iron armatures *a a a a* attached to the piston rod, as they come within the sphere of their attraction, (the cover *c* offering no obstruction to that attraction, as it is of a substance not susceptible of electro-magnetic influence,) whereby the magnets and the armatures become virtually coupled together, and draw along with them whatever carriages may be attached to the carriage which holds the magnets and battery. When it is desired to disconnect a train from the piston, this is effected instantaneously, by disconnecting the wires of the battery from the magnets. Instead of using one electro-magnet for each armature of the form before described, two ordinary horse-shoe magnets may be employed, care being taken that the positive pole of the one magnet shall be placed opposite the negative pole of the other.

To allow air to pass through the piston as may occasionally be required, the discs *dd* of the piston are provided with valves *vv*, which are respectively connected to vertical iron spindles *s*, which terminate within the cover *c* immediately opposite small electro-magnets *nn* affixed beneath the carriages;

Fig. 2.



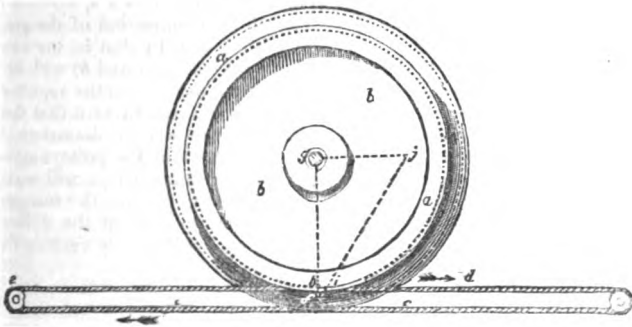
so that when it is desired to open either valve, all that is necessary is to excite the magnet which commands the spindle of the valve (by connecting it to the galvanic battery), on which the magnet will draw the spindle upwards, and thereby open the valve.

*Saxton's Differential Pulley.*—A very ingenious proposition for making use of the power of a horse, moving at his slow working pace, to communicate a high velocity to carriages upon a railway, through the medium of a new arrangement of pulleys and ropes, was invented by Mr. Joseph Saxton, of London, for which he obtained a patent, on the 20th June, 1833. The invention consists in the application of pulleys of different diameters, termed "differential pulleys;" the principle of the action of which will be comprehended by the following illustration:—

Fig. 1 (in the opposite page) represents a combination of two pulleys, their diameters being as 6 to 7; *a* being the larger pulley, and *b* the smaller one; *c d* is an endless rope, passing over the sheaves *e e*; the part *c* of the endless rope first takes a turn round the larger pulley *a*, and the part *d* also takes a turn round the smaller pulley *b*. If then the rope *d* be moved in the direction of the upper arrow, it will draw the lower part of the pulley *b* in the same direction; meanwhile, the part *c* of the endless rope will be moving in the direction of the lower arrow, and will move the lower part of the pulley *a* in the same direction with this part of the rope; consequently, the two pulleys *a b* (which are fixed together) would turn on the mean point *f*, as a fulcrum:

*g* is the centre of the two pulleys. Let it then be supposed, that the part *d* of the endless rope be moved from *h* to *i*, it will be evident that the centre *g* of the differential pulleys *a b* would be moved to the point *j*, and, consequently, if any object were connected to the centre *g* of those differential

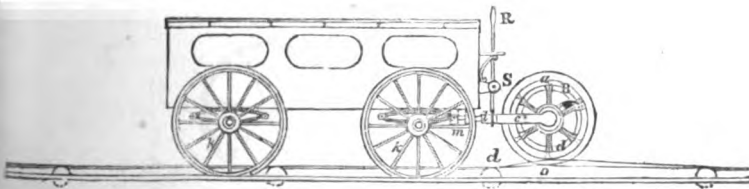
Fig. 1.



pulleys, it would be propelled from *g* to *j*, by the endless rope *c d* being moved the much smaller distance of *h* to *i*, indicated by the dotted lines; and these distances will be as 13 to 1.

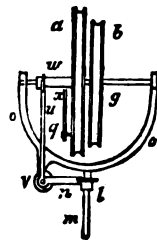
Fig. 2 represents the contrivance applied to an ordinary carriage, having four wheels, as usual, two of which, *k k*, are shown. *a* and *b* are the differential pulleys, placed on an axis *g* (see Fig. 3); *m* is a frame which carries the

Fig. 2.



differential pulleys, and turns in bearings *n n*, affixed to the carriage. The projecting arm *m* is forked at the outer end, as shown in Figs. 2 and 3, at *o o*; and the forked ends serve as bearings to the axle *g* of the differential pulleys, the pulley *a* being permanently fixed to the axle *g*, whilst the pulley *b* is capable of turning loosely on this axis, when it is not retained by the pin *q*, which locks the two pulleys *a* and *b* together at the times required. By disconnecting these pulleys, the power will no longer tend to drive the carriage. *R* (Fig. 2) is a lever, turning on a fulcrum *S*: the upper end of this lever is formed into a handle, and placed under the control of a person sitting in front of the carriage; the other end of this lever receives the flanch of a sliding socket *l* within it, as shown in Fig. 2; *u* is a bent lever, having its fulcrum at *v*, on the forked frame *o*, as shown in Fig. 3. One end of this cranked lever *u* has a crotch, which receives the flanch *l* of the sliding socket; and the other end of the lever *u* has also a crotch to slide the socket *w*, on the axis *g*, backwards and forwards; *x* is an arm, fixed to the sliding socket *w*, and carrying the pin *q*, by which the wheels *b* are fastened together: a spiral spring is placed on the pin *q*, to force

Fig. 3



it in, when a part of the pulley which is cut away comes opposite to the bolt; there is also a spring to prevent a sudden concussion. In *Fig 2*, *c a* is an endless rope, the part *c* taking a turn round the pulley *a*, and the part *d* taking a turn round the pulley *b*, as described in *Fig. 1*. This endless rope is supported, at proper intervals of the road, on sheaves, and passes round a rigger at each end, to which is attached an apparatus for preserving it sufficiently tight. Now suppose the pin *g* to be passed through the two pulleys *a b*, to retain them together, and the endless rope *d* be moved in the direction of the arrow, a similar action will take place to that described in *Fig. 1*; that is, the carriage (being attached to the centre *g* of the differential pulleys *a* and *b*) will be propelled forward on a railway with a much greater velocity than the rope travels; and the distance so travelled by the carriage, in comparison with that through which the rope moves, will depend on the differences of the diameters of the pulleys *a b*; and the nearer the respective diameters of the pulleys approach each other, the greater will be the relative velocity the carriage will travel, to the velocity with which the rope moves. In order to prevent the two parts of the rope rubbing against each other, in leading on and off the differential pulleys, the axis *g* of these pulleys is placed at an angle a little varying from a right angle with the direction of the motion of the carriage.

Fig. 4.

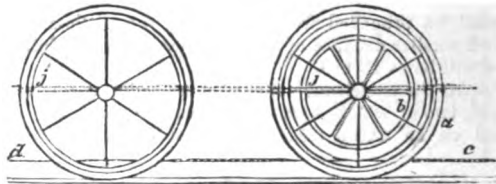
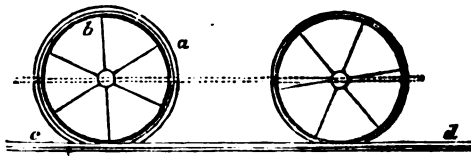


Fig. 5.

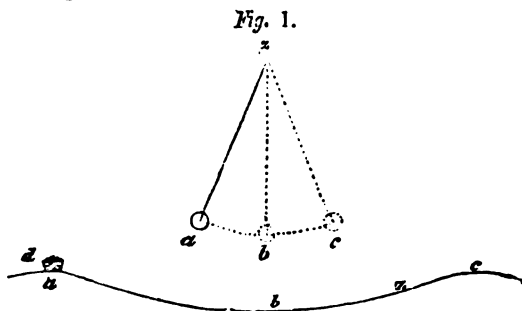


*Figs. 4* and *5* show two different applications of the invention from that shown in *Fig. 2*; for in these instances there is only one pulley, whilst the two front or two back wheels of the carriage act the part of the other pulley. In *Fig. 4*, *a* is one of the front wheels of the carriage, which also acts as the larger pulley; *b* is the smaller pulley, and is the only one around which the rope *c d* passes; the wheels *a*, and the pulley *b*, being on the same axis *g*, which runs from side to side of the carriage, and turns in bearings affixed to the carriage. In this arrangement the point *f*, at which the wheels touch the rail, becomes the fulcrum on which the wheel *a* turns; and it will thus be evident that if the rope *c d* be drawn forward in the direction of the arrow, a similar effect will be produced as described in *Fig. 2*, and as shown in dotted lines in *Fig. 4*. Nevertheless, if the wheels and pulleys *a* and *b* be of the same relative diameters as those in *Fig. 2*, the carriage at *Fig. 4* would only be propelled at the velocity of seven to one, owing to the fulcrum, at which the wheels *a* turn, being removed from the mean point *f*, *Fig. 2*, between the two diameters, and placed at the extreme end of a radiating line, drawn from the centre of the wheel *a* to the point at which it touches the railway. In *Fig. 5* the rope is passed around the pulley *a*, which is the larger, whilst the carriage-wheels act the part of the smaller pulley *b*, the pulley *a* and the wheels *b* being on the same axis *g*. In order that the pulleys in this arrangement may stand at an angle for clearing

the rope, the axle *g* is formed of three parts, connected by universal joints; and one of the wheels *b* thus travels a little forwarder than the other, and thus the rope will clear itself. And it should be observed, that in both these arrangements, the pulley around which the rope passes is to be made capable of being disconnected from revolving with the axle as described in *Figs. 2* and *3*. In the arrangement, *Fig. 5*, the fulcrum *f*, on which the wheels turn, is the point at which the wheel *b* touches the rail or road; and the difference in the arrangements, *Figs. 4* and *5*, is, that the power in *Fig. 4* is applied by the rope between the fulcrum *f*, and the centre *g*, of the wheels or pulley *a b*, where the weight to be drawn is attached: whilst in *Fig. 5*, the fulcrum is between the centre of the pulley and wheels *a*; consequently, the arrangements differ in the order of leverage, and, in this instance, will be as six to one. In these two last arrangements, the rope *c d* may be either an endless rope, as described in *Figs. 1* and *2*, or the rope may be single, and, taking a turn around the pulley *a* or *b*, is to be wound on a drum at each end of the distance which is to be run by one length of a rope.

*Badnall's undulating Railway.*—A very singular and interesting proposition has been made by Mr. Richard Badnall, for travelling upon undulating lines of railway in preference to straight or level lines, with the view of saving locomotive power, by the application of the natural force of gravity in the descent, so as to obtain a great momentum in making the succeeding ascent. His plan is best explained by himself in the specification of a patent, dated the 8th of September, 1832, which he obtained for that object.

“If a plummet suspended by a string, (as in *Fig. 1* in the annexed engraving,) from the point *z*, be drawn away from the perpendicular line to the point *a*, and there let go, it will fall by its gravity to *b*, in the arc *a b*; but, in its



*Fig. 2.*

falling, it will have acquired so much momentum, as will carry it forward up to a similar altitude at the point *c*.

“Let it be supposed that a line of rails, or tram-way for carriages, be so constructed from the summit of two hills, as *Fig. 2*, across a valley, that the descent from one hill, as *a*, to the valley *b*, shall subtend a similar angle from the horizontal line to the ascent up the other hill from *b* to *c*. Now if a train-waggon, as *d*, be placed at the summit of the declivity *a*, it will, by its gravity alone, run down the descending line of rails, to the lowest point *b*; but in so running, according to the principles of the oscillating pendulum, it should have acquired a momentum that would carry it forward without any additional force up the ascending line to the summit of the hill *c*, being at the same altitude as the hill *a*. It is quite certain that this would really take place if the force acquired by the momentum was not impeded by the friction of the wheels of the carriage upon their axles, and upon the rails on which they run. Hence, subtracting the amount of friction as a retarding force from the momentum which the carriage has acquired in descending from *a* to *b*, it will be perceived, that the force of momentum alone would only impel the carriage part of the way up the

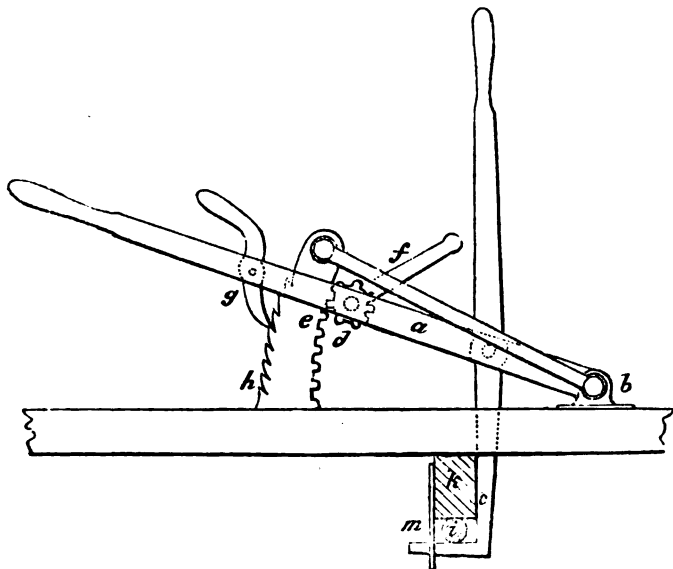


ascent  $b c$ , say as far as  $x$ . It must now be evident, the carriage  $d$  would not only pass down the descending line of road from  $a$  to  $b$  by its gravity, but that the momentum acquired in the descent would also impel it up the second hill as far as  $z$ , unassisted by any locomotive power. In order, therefore, to raise the carriage to the top of the second hill, I have only to employ such an impelling force as would be sufficient to drive it from  $x$  to  $c$ , the whole expense of locomotive power for bringing the carriage from  $a$  to  $z$  being saved. If now I employ a locomotive power to assist in impelling my carriage from  $a$  to  $b$ , I, by that means, obtain a greater momentum than would result from the descent of the carriage by gravity alone, and am enabled by that means to surmount the hill  $c$ , having traveled the whole distance from  $a$  to  $c$ , on the undulating line of road, with the exertion of much less locomotive power than would have been requisite to have impelled the carriage the same distance upon a perfectly horizontal plane." Having thus explained the principle of his invention, Mr. Badnall claims the formation of tram and railroads, with such undulating curves as are adapted to his object. This invention has been the subject of much able controversy in the *Mechanics' Magazine*, and some other public journals, of which our limits render it impossible to give any account. The plausible arguments which were raised in support of the inventor's theory, led to some public trials on the Manchester and Liverpool railway; which, although conclusive as to its inefficacy in the minds of most persons who doubted before, has apparently had the effect of confirming the patentee in his prepossessions of its utility.

*Rope traction.—Blackwall Railway.*—On the Blackwall railway the traffic is carried on by means of ropes worked by stationary engines, erected at each end of the line. This system has been adopted on account of the number of intermediate stations along the line, the line being only about  $3\frac{1}{4}$  miles long, and having five intermediate stations. And had locomotives been employed, the time lost in stopping and starting the trains would have exceeded that occupied in traversing the lines. The line is worked as follows:—supposing the train to be that which is passing from London to Blackwall; at each of the intermediate stations is one or more carriages, for the conveyance of the passengers from those stations to the Blackwall terminus, and at the London terminus is ranged what may be termed "the train," consisting of one or more carriages for the Blackwall terminus, and one or more for each of the intermediate stations; the Blackwall carriages being the first in the train, and those for the intermediate stations being ranged in the order of the proximity of the stations to the Blackwall terminus. The several carriages being attached to the rope, the engine at the Blackwall end of the line is put in motion, and the carriages from the intermediate stations arrive in succession, at intervals, at the Blackwall terminus; the carriages, being detached from the rope (without stopping the rope) as they successively arrive within a certain distance of the terminus, and being stopped at the proper point by a powerful brake attached to each carriage. In like manner the carriages for the first intermediate station from London (and which carriages will be the last in the train) will be detached from the rope as they arrive within the prescribed distance from the station, and so on with the carriages for the remaining stations, until the leading carriages from London arrive at the Blackwall terminus, which completes the operation, and the rope is then stopped. This system of working the line has the advantage of delivering the passengers at each intermediate station without detention to the other carriages, but it is attended with this inconvenience, that the intermediate stations have no communication one with the other, but only with the termini: for instance, a person could not proceed from Stepney to Poplar, but would have to go on to the Blackwall terminus.

The accompanying figure represents the apparatus for attaching the carriages to the rope, which combines the advantage of a powerful grip with a ready means of casting off the rope.  $a$  is a forked lever turning upon a fulcrum at  $b$ , at the fore end of the carriage, and carrying within the fork the hanging clutch or nipper  $c$ ;  $d$  is a pinion supported by the lever  $a$ , and working in a

toothed standard *e*, which is bolted to the frame of the carriage; by turning this pinion by means of the handle *f*, the lever *a* can be raised to any required position, and may be retained therein by the pall *g*, which takes into the teeth of a ratchet, *h*, cut on the back of the standard *e*: *i* is the traction rope, *k* a block of wood attached to the under side of the carriage, against which the rope

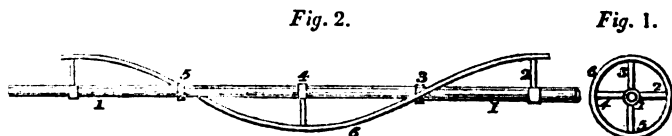


is firmly jammed when in action; *m*, is a forked cheekpiece attached to the side of the block to prevent the rope flying off laterally. When the rope is detached, the apparatus assumes the position indicated by the dotted lines. To attach the carriage the rope is lifted on to the claw of the nipper, which is then thrown into a vertical position, and the lever *a* is wound up until the rope is bound firmly to the block, and the pall *g* is put down. To release the rope, the pall is thrown back, and the lever *a* falls into a horizontal position, and the nipper being thrown into the inclined position shown by the dotted lines, the rope is thrown off.

The railway is worked by two pairs of stationary engines, of 400 and of 200 horse-power respectively, at the Minories and Blackwall termini. The ropes are not worked on the plan of endless ropes, but there are two distinct ropes, one to each line, extending along the length of the railway, guided by grooved pulleys, and coiled round drums, twenty-two feet in diameter, situated at each end of the line, and worked by the engines; the one drum giving out the rope as fast as the other winds it up, so that each rope is twice the length of the railway. The drums are formed like sheaves, or pulleys, with a very deep groove, which becomes gradually narrower as it approaches the centre, so that the rope, when coiled upon the drum, forms numerous layers; and this tends in some measure to equalize the load upon the engines; for, at starting, when the number of carriages is greatest, the virtual diameter of the drum is least, and the advance of the train during a revolution of the drum is, consequently, least; but, as the train advances and becomes lighter, by a portion of the carriages being detached as they successively arrive at the intermediate stations, the virtual diameter of the drum is increased by the additional layers of rope it has received, and the speed is consequently proportionately increased. The carriages run each way upon each line; and the signals for starting, and the general working of the train line, are given by the electric telegraph. At first, hempen ropes were employed, but, owing to the inconvenience and delay

occasioned by their frequent breakage, wire ropes, with swivels at given distances, have been substituted; and now, in about 2,000 journeys each way per month, not above two fractures occur. The wire rope now used is formed of six strands laid round a hempen core, and each strand is composed of six wires, also laid round a hempen core. In a paper by Mr. A. J. Robertson, read at the Institution of Civil Engineers, it is stated, that the power to move the rope alone was about 200 horse power, for a hempen rope, and with the wire rope, on account of its greater weight, it required about 250 horse power. The expense of working the engine and rope is stated to be about fourteen-pence per train per mile, but the author observes that the question of expense must not be considered abstractedly; it must be remembered that the traffic could not be carried on at the requisite speed by locomotive engines if they had required to stop seven times in  $3\frac{1}{2}$  miles,—it was, therefore, a question, whether the system of rope traction, by which the traffic could be carried at a given speed, or whether the intermediate traffic, should be abandoned. The latter, commercially speaking, could not be done, and the rope system is therefore persevered in.\*

*Farrell's Patent Archimedean Railway.*—This invention appears to possess considerable originality as well as ingenuity; but whether it can be made to work on the great scale, as well as we are told it does in the model, is a question upon which great doubts will be entertained, until experience shall decide it. The patentee distinguishes his scheme from all other plans of propulsion on railways by the term *Archimedean*; and he designates his chief movement the "screw propeller." Both these terms are calculated, in our opinion, to impress an erroneous idea. We should rather describe it as a *helix* of uniform obliquity, not connected solidly to the axis (as screws are), but with a space of about eight inches between one and the other; the connexion between the two being effected by a series of radiating arms, at about three feet distance apart throughout the entire line of railway. The annexed diagrams will make this construction quite clear.



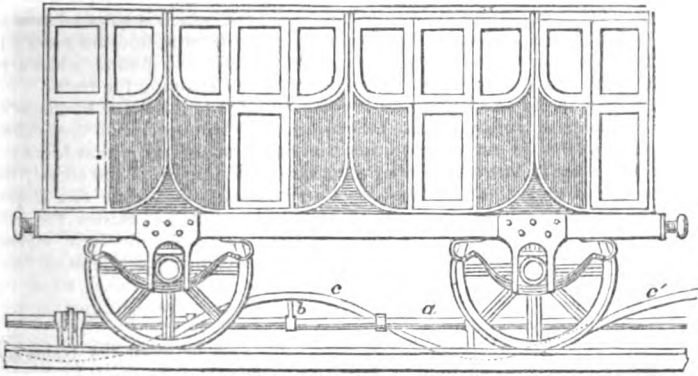
The above *Fig. 1* is an end view of the helical propeller, and *Fig. 2* is a side or longitudinal view. In the centre 1 1 is represented the tubular axis; 2, 3, 4, and 5, are the arms of the propeller, and 6 shows the helix, winding round the axis. These parts are very nearly in their true proportion: it is intended to make the propeller in twelve feet lengths, and the diagram shows one of such lengths throughout which the helix makes but a single revolution. Thus every revolution of the screw is designed to propel the train of carriages twelve feet along the rails. Having premised thus much to explain the construction of the "Archimedean screw," we shall avail ourselves of the patentee's specification in our further description, which has reference to the engravings which follow.

"This invention consists in the use and application of a screw, *a b c* (*Fig. 3* subjoined), which is called the "screw propeller," for the purpose of locomotion on railways, and by means of which the moving power is communicated to the trains. This screw is laid down continuously in the middle of the track, and is fixed in the direction of its length, but caused to revolve upon its axis by steam or any other power communicated to it at proper intervals,—say every three miles along the line. This screw may be of any given diameter, say from eighteen to twenty-four inches, formed in lengths of from twelve to fifteen feet each, and consists of a shaft *a* of cast or rolled iron tubing, four inches in diameter, supporting by means of wrought iron arms *b b*, keyed on to the shaft, a rolled

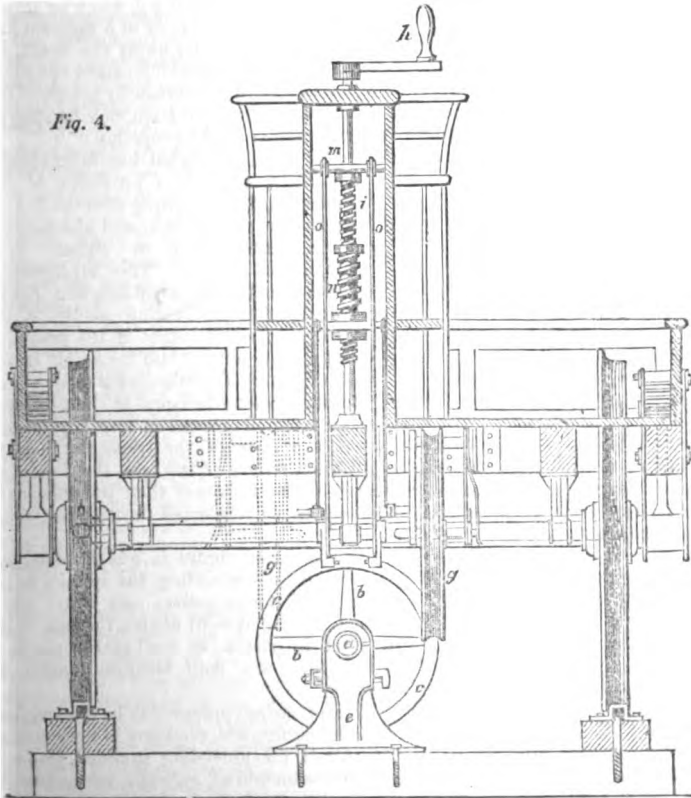
\* Since the above was written, it has been decided to discontinue the use of the ropes, and to substitute locomotive engines for them.

iron spiral *c*, which is bolted to the ends of the arms; the construction is such as to afford perfect confidence in its strength for its intended purpose. The

*Fig. 3.*



*Fig. 4.*



lengths of shafting are connected by couplings, that allow a sufficient play to meet any accidental irregularity in the line, and also to permit them to be laid

down on the quickest curves that are allowable on railways, with scarcely any calculable amount of friction: each length rests on turned bearings, in proper metal pedestals *e*, secured to the cross sleepers of the railway. The power is communicated to the screw *a b c* by means of spur wheels, fixed on one end of each line of shafting of one and a half mile in length, which is situated so as to drive two such lines, that is, one in each direction from it, and the gearing is so contrived as gradually to bring the screw propeller into motion, and also to transfer the power from one line to the other without stopping the train.

The motion of the screw propeller is communicated to the trains by means of a pair of wheels or rollers *g g*, so attached to the frame-work of the leading carriage of the train as to bear upon the rim *a*, spiral rail *c*, that forms the thread of the screw, one wheel being at either side of the axis of the screw; the position and arrangement of these wheels *g g* is such, that while one is propelled by being borne against by the thread of the screw, and carries the train forward, the other acts as a check wheel, and prevents the train from moving with an unequal motion, or running forward by acquiring acceleration; and the screw propeller being capable of acting in both directions, when the motion is reversed, that which before acted as a check wheel becomes the propelling wheel, and *vice versa*.

These wheels *g g*, which form the only connexion between the trains and the propeller, are perfectly under the control of the conductor, who, by turning the handle *h* of the vertical screw *i*, compresses the wheels *g g*, when he thinks it necessary, with more power upon the screw propeller, or in a moment disengage them from it, and having done so, can instantly apply the break, by continuing the same movement of the vertical screw *i*, which causes the nut *n* to press the cross beam *m* upwards, and bring down the break by means of the suspension rods *o o*, upon the bearing wheels. Thus, the train may be stopped at any points, without interfering with the motion of the propeller.

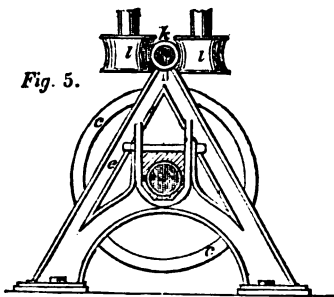
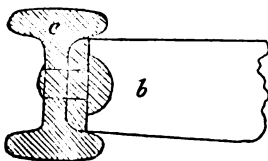


Fig. 5.

In addition to what has been already described, there is a provision in this invention, for dispensing with the flanges on the bearing wheels, and also for conveying intelligence or signals from station to station. This arrangement is shown in the subjoined diagram, *Fig. 5*; in this case, the bearing saddles *e*, are triangles the full height of the propeller, and a guide rail *k* is laid the whole length over the propeller; this rail is made of iron tubing, in lengths equal to the propeller, and fastened or screwed into sockets cast on the apex of the triangular bearing saddle *e*; against the guide rails, the friction rollers *l l* run, and the flanges on the bearing wheels are thus dispensed with; the rails may then be reduced to a flat iron bar. It is proposed that signals be conducted through the tube *k* from station to station.



The annexed figure is added, to explain the means of connecting the spiral *c* to the arms *b* of the propeller; the latter has a flange turning at right angles, through which a rivet is passed, as well as the spiral *c*, when they are both strongly united by riveting.

The advantage proposed to be derived from this invention, are, economy in the construction of railways, from the facility it affords for ascending inclined planes of almost any angle, and the consequent reduction of cuttings, embankments, bridges, &c.; also, in the use of light rails instead of the heavy rails required for the locomotive system; and in the use of lighter carriages than those at present in use, and hence, less useless load.

Economy of power for locomotion, by the use of fixed engines, or water power in place of locomotive engines, and the consequent avoidance of the expense of erection and support of those costly establishments required for the latter.

Safety to passengers, by collision or the running of the trains off the rails being rendered impossible.

Before proceeding to give an estimate of the expense of construction, or of power for locomotion, on this system, it may be well to consider for a moment the amount of friction due to such a line of shafting as I propose, and also its power of resistance to torsion.

On the subject of friction, a good deal has been written, and many experiments are recorded, but I prefer taking my data from actual observation: I have therefore made several experiments on different lengths of shafting, some very favourable in their results, and others the reverse; the most unfavourable was one consisting of four different lengths at right angles to each other, and coupled by bevel-wheels; the result was something less than the  $\frac{1}{3}$ th of the load, or 120lbs. to the ton. I take this, being the least favourable, as the standard from which the following calculations are taken.

The weight of a mile and a half of the screw propeller, including gearing, will not exceed 80 tons, which at 120lbs. to the ton, leaves 9,600lbs. as the amount of friction; the bearings are 3 inches, and the pinion on the end of the shaft to which the power is applied 18 inches diameter, or as 6 to 1; therefore the power required to turn a line of shafting 80 tons weight, from a state of rest, applied at the periphery of the 18-inch pinion is 1,600lbs., or  $\frac{1}{6}$ th of 9,600lbs. The shafting is proposed to be formed of iron tubing, 4 inches diameter, and half an inch in thickness; the weight found by accurate calculation, and proved by experiment, as sufficient to twist such a shaft if applied to the periphery of an 18-inch pinion fast on it, is 22,196lbs.; now, as half the breaking weight may be applied, without producing any deflection, we have a shaft to which we may apply 11,100lbs. at the periphery of an 18-inch wheel, with perfect safety, without producing any torsion whatever. Now the power required to turn a mile and a half of screw propeller, from a state of rest, is 1,600lbs., which is about  $\frac{1}{6}$ th of the power that may with perfect safety be applied to the 18-inch pinion, or, in other words, the shafting might be extended to seven times the length I have proposed without being subject to any torsion whatever.

With respect to the applicability of this system to curves, let us suppose the propeller to be laid down on a curve of 1,320 feet, or one quarter mile radius, and the shafting in lengths of 12 feet, it is evident that each length of shafting will form the base of an isosceles triangle, whose sides are 1,320 feet and base 12 feet, or as 110 to 1.

On calculating the angles at the base of this triangle, it will be found that the friction of the couplings, which are 3 inches diameter, will be something less than  $\frac{1}{8}$ th of an inch, or  $\frac{1}{10}$ th part of 3 inches.

Again, although the curve is formed of a series of straight pieces, 12 feet long each, yet as the versed sine of the arc of which the 12 feet length forms the chord is but a small fraction more than one quarter of an inch, it will be seen that so small a deviation from the curve cannot be so much as felt in practice.

With respect to the power required for this system, it has been shown that 1,600 lbs. applied to the periphery of an 18-inch pinion will be sufficient to overcome the inertia of a mile and a half of propeller, and set it in motion, round its axis. Now suppose the pitch of the screw to be 12 feet, then every revolution it makes on its axis impels the train 12 feet, and 154 revolutions per minute will impel the train at the rate of 21 miles an hour; to obtain this speed we require a spur wheel  $5\frac{1}{2}$  times the diameter of the pinion, or 8 feet 3 inches in diameter, making 28 revolutions in a minute. If this spur wheel is turned by a 2 feet crank, the radius of wheel being 4 feet  $1\frac{1}{2}$  inch, it follows, that in order to apply a power equal to 1,600 lbs. at the periphery of the spur wheel, we must apply twice and one-sixteenth of that power, 3,300 lbs., to the crank; this

power would be afforded by a condensing engine, 24-inch cylinder, 4 feet stroke, and making 28 strokes per minute, or 18 horse power.

The foregoing calculations are made without any reference to the provision spoken of, for bringing the propeller gradually into motion; but as such provision is made, and it is known that half the power that is required to set a machine in motion is sufficient to continue that motion, we may safely calculate on one half the power above stated, or 800 lbs., as available for the purpose of propelling the trains. Now, as the circumference of the pinion is 4 feet 6 inches, and the pitch of the screw 12 feet, the effect will be as  $4\frac{1}{2}$  to 12, and taking the friction of the train as 9 lbs. per ton, we have a power equal to the propulsion of  $33\frac{1}{2}$  tons, or eight loaded carriages of more than 4 tons each; but as one of the great advantages this system possesses over any other, is the facility it affords for transmitting a succession of trains at very short intervals, provision may thus be made for the most extensive traffic without increasing the engine power: for instance, a train capable of carrying 50 tons on the present system, could be divided into four trains of five or six carriages each, at ten minutes intervals, an arrangement by which 900 tons of goods, or 12,960 passengers, might be conveyed in a day of twelve hours, and the expense of locomotion not exceeding six shillings per day, as may be seen by the following estimate, which includes interest on capital sunk in engines, engine-houses, and machinery, and the daily expense of locomotion.

	£	s.	d.
Estimate of one mile of screw propeller.			
33 tons cast iron shafting, including the bearings and fitting the coupling joints, at £10 . . . . .	330	0	0
17 tons, wrought and rolled iron, in arms and spiral, the arms driven on hot and keyed, and the spiral secured to the arms with hot rivets, at £17 10s. . . . .	297	10	0
10 tons of cast iron, in saddles or pedestals, by which the propeller is supported, at £7 . . . . .	70	0	0
1 ton of wrought iron in screws, pins and keys . . . . .	20	10	0
1,760 yards of screw propeller laid down for fixing, bushings and sundries, at 1s. 6d. . . . .	132	0	0
	<u>£850</u>	<u>0</u>	<u>0</u>

Estimate of power for locomotion on three miles of double line of railway.

1 steam engine, 20 horse power, or two 10 horse engines, including gearing, at £30 . . . . .	£600	0	0
Engine house and sundries . . . . .	250	0	0
	<u>£850</u>	<u>0</u>	<u>0</u>

Interest on £850, at 5 per cent. per annum . . . . .	£42	10	0
Coals for one 20 horse engine, working 12 hours per day, 365 days at 8s. per day . . . . .	146	0	0
Attendance, wear and tear, and sundries . . . . .	150	0	0
Apparatus connected with the carriages : . . . . .	50	0	0
	<u>£388</u>	<u>10</u>	<u>0</u>
	64	15	0

Interest on £850, the first cost of propeller at 5 per cent. . . . .	42	10	0
Total annual expense of one mile . . . . .	£107	5	0

Thus the total expense of locomotion for a single mile for one year is £107 5s. 0d. not quite 6 shillings per day of 12 hours. The foregoing estimates, show the expense of the system, as applied to any part of the present railways;

but in any new railway formed with reference to the application of this system, the saving on the rails alone will pay more than one half the cost of the propeller; and the saving in cuttings and embankments, bridges, &c. will render the formation of railways on this system scarcely, if at all, more expensive than a turnpike road.

The following is an estimate of the upper works of the Archimedean system complete, compared with the locomotive system, omitting those items that are common to both.

ARCHIMEDEAN SYSTEM.

	£	s.	d.
Cost of one mile of propeller as before detailed . . . .	850	0	0
26 tons of cast iron tubing in guide rails at £10 0 0	260	0	0
10 tons of cast iron in additional weight of bearing saddles, at . . . . .	7	0	0
13,640 feet lineal of longitudinal and cross sleepers of Paynized wood, including laying, at . . . . .	0	1	6
1,800 screw bolts and nuts, at . . . . .	0	0	2
Cost of a single mile . . . . .	<u>£2218</u>	<u>0</u>	<u>0</u>

LOCOMOTIVE SYSTEM.

13,640 lineal of longitudinal and cross sleepers, including laying, at . . . . .	0	1	4	£909	6	8
Rolled iron rails, 80lbs. per yard, 126 tons, including laying, the rails, at . . . . .	£10	0	0	1260	0	0
8,840 screw bolts and nuts, in rails and sleepers	0	0	2	73	13	4
Cost of a single mile . . . . .	<u>£2243</u>	<u>0</u>	<u>0</u>			

From the foregoing it may be seen, that the expense of the Archimedean system complete, including (Paynized) wooden sleepers, will not exceed the cost of the upper works of the present locomotive system; that the expense of power for locomotion, for 12 hours continuous traffic, will be less than £65 per mile, per annum; and if it shall be found advisable to double the engine power that I allow, and thus work three miles of propeller at the same time, instead of 1½ mile, by which means the traffic may also be doubled, the annual cost will not amount to £100 per mile of single line, or £200 per mile of double line; while the cost of power on the locomotive system may be taken at an average of £1000 per mile; but on short lines, and where there is large traffic, it far exceeds that sum.

I would in conclusion observe, that all that has been said in reference to the saving that may be effected in cutting embankments, bridges, &c., in the formation of railroads adapted to the atmospheric principle, applies equally to the Archimedean: that saving will be great on the most favourable lines, and in many cases it will amount to thousands of pounds per mile.

*Parkin's Windmill Railway.*—Amongst the numerous suggestions for new modes of propulsion, that proposed by Mr. Thomas Parkin is one which the less informed portion of the public have been led to believe would supersede the use of locomotive and stationary steam engines. The contempt with which Mr. Parkin treats these latter is somewhat amusing. Speaking of a locomotive engine, he says, "it is obnoxious to fearful casualties. Now and then it breaks axles and wheels, and tears up rails, involving consequences so dreadful as to render even allusion to them painful; and it has, on these accounts, too truly been compared to the arch-fiend himself in harness. The weight of a locomotive also constantly injures the road, and subjects it to the necessity of frequent reconstruction; and when it is occasionally out of breath, the discovery is made that it sometimes amuses itself in polishing the rails, instead of making the best of its way home! For all the purposes of locomotion, an enormous fire (which now and then sets trains, standing corn, ricks, farm-yards, and other buildings in a blaze!) is made, and kept up, in order to have a constant

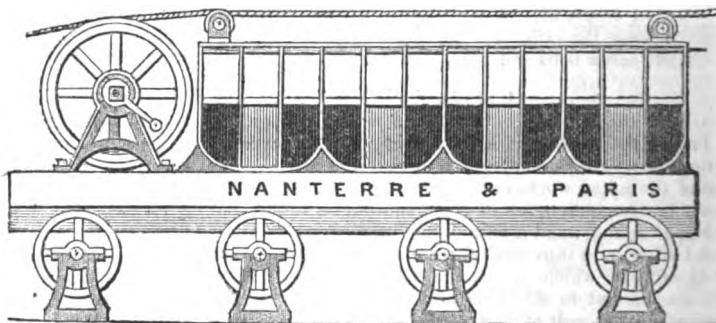


enormous supply of boiling water, (which now and then scalds men to death!) the vapour whereof is confined in an iron case, and gives motion (when unable to burst the case) to a piston, which turns a crank, and thereby the 'driving' wheels of the engine, and this is designated *the locomotive lever*: but where is the fulcrum? Ay, that is the question! Why, the engineers having had as much difficulty in finding a fulcrum for this lever, as Archimedes experienced in finding one to lift the globe, *have contented themselves with the weight of the engine for a fulcrum!*"

After much similar sneering at the most extensively useful invention of modern times, our inventor proceeds to describe what he calls *the new system* (and we prefer his description to our own, for obvious reasons): he says—

"Having disposed of locomotives and tenders, and developed a plan for existing railways, we are brought to the new system of locomotion, which dispenses with tunnels, bridges, rails, steam-tenders, and carriages with wheels and springs, and requires very little land to be bought, and very little earth-work to be done.

"The road is formed of parallel lines of stanchions, mounted with wheels, on which a platform glides, carriages being built thereon, and ribs underneath are its guide. A small amount of power only is required to give motion to the platform, and the saving in the construction of this mode of conveyance is immense. The road, for the most part, will present a series of inclined planes, which the trains will ascend by means of windmills, when there is wind, and



by counterbalances on parallel lines of road when there is none, or not enough. The counterbalances will consist of water, stones, gravel, &c. which the wind will pump and draw up to a height, when not employed to work the platform: and tens of thousands of tons of these substances may always be kept on reserve, to be used when there is no wind, as wind *costs nothing*; as the above-mentioned substances *cost nothing*, and as compressed air, when used, will *cost nothing either*, locomotion (incredible as this at first sight may appear) will in reality *cost next to nothing*. The system, however, may of course be worked by those who would be horror-struck at the idea of getting rid of all expenditure at a tangent, by small steam engines. The platform may be of any length, and will always have a bearing on six or eight wheels in succession, and may weigh two tons, carrying as many passengers as ten railway carriages accommodate. The carriages, and truck or baggage waggon, weigh about 45 tons; consequently here will be a diminution of weight of 43 tons, say 40. A point is thus gained of inappreciable value, but when we add 15 tons, at least, for the weight of the locomotive and tender, we have a saving in weight of 55 tons in each train; that is, we save the fire necessary to reproduce steam enough to waft 55 tons through the air at railway speed! A single comment upon the advantages here offered to the public would be unnecessary."

We have been induced to notice this invention, solely from the circumstance of its being publicly stated to be under course of trial in France, and not from having the remotest idea of its success.

## SECTION V.

### TELEGRAPHIC AND SAFETY ARRANGEMENTS.

Prevention of Accidents from Collision.—Curtis's Lamp Signals.—Hawkehaw's Signals and Switches.—Steam Whistle.—Taylor's Guard's Signals.—Porteous's Mouth Whistle.—Electric Telegraph—principles upon which its action depends.—Cooke and Wheatstone's two arrangements of the Electro-Magnetic Telegraph.—Professor Morse's Apparatus for preventing Collision between Trains.

*Prevention of Accidents on Railways from Collision.*—The most numerous accidents on railways, and at the same time the (generally) most disastrous in their effects, are those resulting from collision, either between two trains, or between the carriages composing one train, from an accident to the engine or leading carriages; and in the present section we propose to notice some of the means employed to guard against dangers from this cause.

Collisions on railways take place under various circumstances. It may sometimes happen that two trains, proceeding in opposite directions, are at certain parts of the road obliged to travel on the same line of rails, and should they at such time come into collision the results must be the most disastrous. Accidents of this description are however very rare, and unless at sharp curves, or in very foggy weather, could only arise from extreme heedlessness on the part of those employed on both trains. Collisions more frequently arise from a train overtaking another train, proceeding in the same direction, or from a train arriving at a station, which is unexpectedly occupied by another train. In all cases they may be said to arise from some irregularity in the working at some part of the line, and might be avoided if timely notice were given of such irregularity; and accordingly various kinds of signals are employed or have been proposed to effect this, some being produced by sounds, others being addressed to the eye, and in other cases both sound and visible signals being employed.

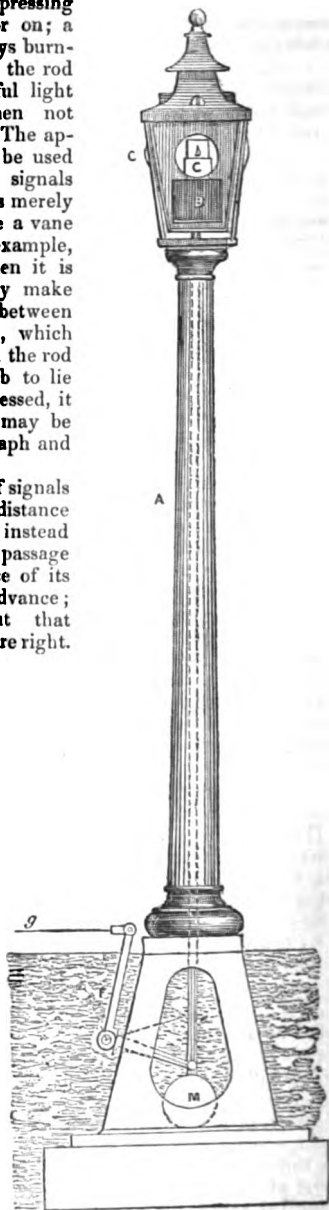
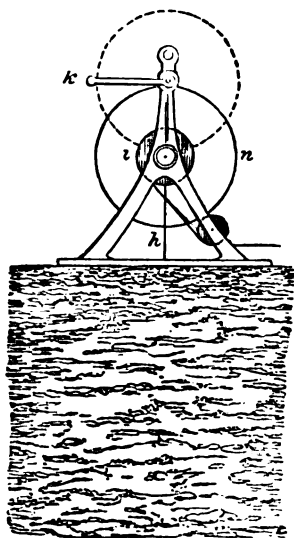
The figure (page 524) represents Mr. Curtis's apparatus for giving notice of the approach of a train to a station, or warning to a train that the station is occupied.

The peculiarity of the plan consists in conveying the signal a mile, or any convenient distance, from the station, with the object that the engineer may pass the signal post, and have distance and time sufficient to stop the train, before reaching the station, or place for stopping. The figure represents the apparatus for exhibiting a light.

"A is a lamp-post surmounted by a lantern of any peculiar shape, with bulls' eyes on three sides, or it may be formed of glass like a street lamp, or in any other manner. c is the lamp with reflectors behind the light in the usual way. s is a shade supported upon the vertical rods e, passing through the post and united by a joint at its lower end with the bell-crank r, to which is likewise suspended the ball or weight m. To the other end of the crank r a joint is attached, with which is connected a strong wire g, which is led like a bell-wire by proper connexions to the crab h, placed in a room of, or near, the station house. The wire, or a chain or rope united to its end, is fastened to the barrel i of the crab h which coils round the barrel. When a man turns the handle k, the barrel i is turned round by means of the pinion fixed on the handle shaft, and the barrel wheel denoted by the circle n; and the chain or rope or wire is coiled round the barrel, the wire drawn in, and the crank r made to occupy the place shown by the dotted line; and thus the vertical rod e and shade s are raised, and the light concealed. The counterbalance m is employed to keep the connecting wire g always stretched. In places where gas is employed, a large gas burner may be substituted for the lamp, and the rod e made to communicate

with a stop-cock, so that by raising or depressing the rod, the gas may be turned off or on; a small concealed jet of gas may be always burning, so as to inflame the larger jet when the rod is raised by the apparatus: thus a powerful light may be used when needed, and when not required, the gas may not be wasted. The apparatus as drawn is a night signal, or to be used when the weather is so dark that other signals cannot be seen; but for a day signal it is merely necessary to employ a post, so as to raise a vane or vanes like a telegraph, a spar, for example, fixed at the top of the lantern. When it is required to use the telegraph, a man may make the necessary and self-evident connexion between the rod *e* and the limb of the telegraph, which limb being made with a bell crank, when the rod *e* is raised, may cause the telegraph limb to lie horizontally, and when the rod *e* is depressed, it will stand vertically, or the apparatus may be formed double, so as to work both telegraph and lamp at once, whether by day or night.

The best arrangement of this system of signals will be, to place them at the same distance asunder as the police are stationed; and instead of making a signal by a flag, upon the passage of a train, they should convey the notice of its approach to the next policeman in advance; which would advise him to look out that switches, points, and everything besides are right.

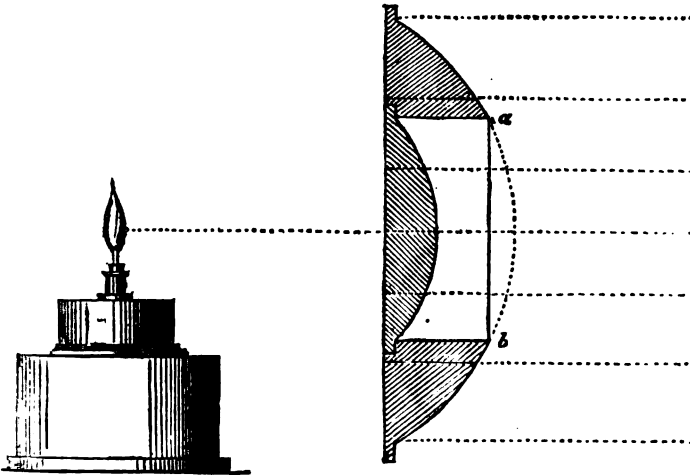


By a self-evident modification of this apparatus, the engine can be made to communicate its own approach.

Mr. Mallett of Dublin described in the *Mechanics' Magazine* a lamp of his invention, which he denominates the *polyzonal* lamp, and of which we extract the following description.

*Mallett's Polyzonal Lamps.*—"Brilliancy and space-penetrating power, in the light of railway signals, is of the highest importance; and equally, or even more so, are the signals of steam-boats, &c.

"As the thickness at the centre of the lens of a railway signal lamp depends upon the distance of the lens from the flame of the lamp, in order that the divergent rays may be transmitted parallel; and as this distance is, on account of the limited size of the lamp, small, so the lens, as usually constructed, is very thick, generally from 2 to 2½ inches in the centre; and being generally coloured red or some other colour the loss of light by absorption is very great.



"The figure represents a mode of obviating this, which I have adopted, by an application of the polyzonal lens of Fresnel. The lens is cast in two parts,—the outer or annular lens, and the inner or central one, then ground so as to have a common focus. The inner lens is fitted to the rebate of the annular one, by a little Canada balsam or other suitable cement; and thus the compound lens, at a small additional expense, has less than half the thickness at the centre of the common one, and as short a focal length with much greater penetrative power.

"Weight is also saved in the lens, which is of importance in railway signals, when mounted aloft in stormy weather, and it economises the coloured glass.

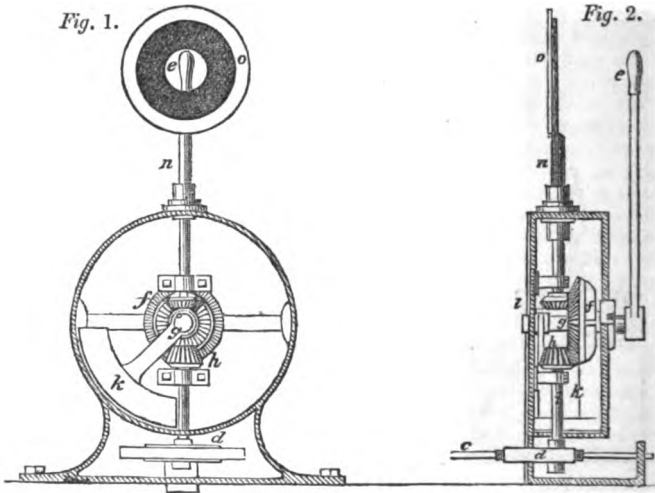
"The lenses, to be completely cleaned, must be washed outside to clear out dust from the sharp re-entering corners of the central lens, but even this might be avoided by fitting and cementing a circular disc of thin plate glass over the central space, from *a* to *b* in section, to keep out the dust."

*Hawkshaw's Signals and Switches.*—In the generality of cases, there is one position of the switches, or shunts, which is necessary for the thorough or principal traffic, and in which direction the trains have to pass at a maximum velocity, while the change that is given by the other position of the switches is less frequently required, and is chiefly passed over by trains at a slow rate. The principal object of Mr. Hawkshaw's invention is, to secure the switches being held or kept in a proper position at all times for the principal or thorough



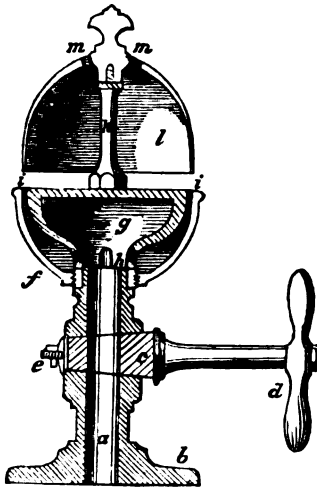
traffic; and when there is occasion to transfer the trains or engine, &c. to another line from that on which the chief traffic passes, it has to be done by some person holding the switch protector in a proper position for that purpose; and immediately after such transfer from one line to the other has been effected, he lets go his hold upon the handle of the apparatus, and it will from its self-acting construction, instantly and of necessity return to its original position; moving at the same time the switches or double rails in connexion therewith in the right direction for the principal or thorough traffic, and maintain them in that position, so as to prevent the possibility of the main lines of rails being left unconnected.

In the subjoined illustration of the invention, *Fig. 1.* is designed to show a front elevation, but with the front plate removed to exhibit the interior mechanism; and *Fig. 2.* is a side elevation at right angles to the former. It



will be apparent that by depressing the lever *e* into the horizontal position, the bevelled wheel *f*, on its axis *g*, will actuate two bevelled pinions *k* and *l*, the lower one *k* turning on the vertical spindle *i*, the other end of which carries an eccentric, *d*, that turns the switch or double rail placed in connexion therewith, (but not introduced into the drawing,) in the exact position required for directing a train out of the main into a diverging line: at the same time the upper pinion *l*, through the medium of its vertical spindle *n*, turns a signal disc *o* into the position delineated in *Fig. 1.*, which is at right angles with the direction of the main line. The depression of the lever *e* produces a third effect, that of raising a counter balance weight *k*, which is keyed to the axis *g*; so that when the train has passed into the diverging line of rails, the attendant has only to suffer the weight to operate, which brings the lever *e* into the vertical position again, and thereby places the signal disc *o* in its former edgewise position, indicating that the main line is open for the passage of trains. When the continuity of the main line is broken by the position of the switches, the attendant is necessarily there attending it, and the signal also shows to the engine-man of an approaching train that such is the case, in time for the shutting off the steam, and the application of the drags. But as the reconnecting of the main line does not depend upon the vigilance of an attendant, but is forcibly self-acting, the risk of accident from the erroneous position of the switch mechanism is reduced almost to an impossibility. To render the signal visible at night, a lamp is placed in the centre of the disc. [London Journal, October, 1839.]

*Steam Whistle.*—The construction of this very powerful means of communicating intelligence by sound is shown in the annexed *Fig.*; it is all of brass, and the foot *a* is cast hollow with a flanch *b* at the bottom, to bolt it upon the fire-box; it has a cock *c* placed in it with the handle *d* and screw *e* to keep it tight; the handle projecting out to allow firm hold to be taken of it. The cup *f* is fixed upon the foot *a* by screwing the piece *g* upon it, and both are turned truly at their outer edges, leaving a very narrow passage *i* between them all round. The piece *g* is hollow, having holes *h* in its sides, and a pillar *k* stands upon its centre, on which is screwed the bell *l*; the thin edge of which is brought just over the opening *i*, and half an inch above it. When the cock is opened, the steam enters the cup *f* through the holes *h*, and rushes out at the narrow slit *i*, striking the thin edge of the bell *l*, in a similar manner to the action in organ pipes, and producing an exceedingly shrill sound: some holes *m* are made in the top of the bell, to allow the steam to pass freely through, which improves the sound considerably. The cock is required to be steadily opened to adjust the quantity of steam, so as to produce the clearest sound. The steam whistle is very effective, and its sound can be heard at a great distance.



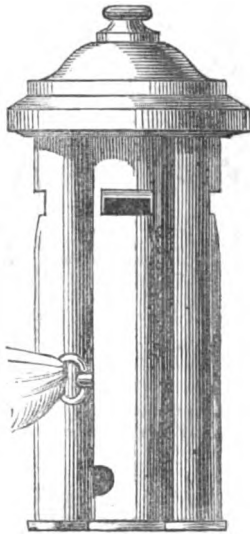
*Captain Taylor's Railway Guard's Signals.*—Notwithstanding the many plans which have been proposed for the purpose, there is not yet a single invention which has been brought into use for effecting the much wanted communication between the guards and the engineers.

About twelve months ago, Captain Taylor, R. N. submitted to the Admiralty an instrument for giving signals to steamers and other vessels, which he called a *telephone*, the sounds from which could be heard for a distance of three miles. This instrument was a modification of an invention, patented a year or two previously, by Mr. C. Hood, F. R. S., which was intended to accomplish the object above proposed, of effecting a communication between the guards and engine-men on railways, and also for marking by signals the track of steam vessels in foggy weather. For both these purposes the invention appears to be perfectly applicable.

The object is accomplished by means of a whistle, similar to that used on the locomotive engines, and worked by compressed air instead of steam. Under the frame of the carriage on which the guard has his seat, is fixed a condensing air pump, worked by a pinion fixed on the carriage axle. The condensed air is received into a vessel holding about two cubic feet; into this vessel the air is pumped until the pressure is about 50 or 60 lbs. on the square inch, when the guard by a motion of his hand or foot throws the pump out of gear, to be again brought into gear by the same means when required. Connected with this vessel is a pipe, terminating in a whistle, similar to the high pressure steam whistle, but with all the passages made very much finer and smaller. On the fineness of these passages much of the efficiency of the instrument depends, for there being no condensation of steam, as is the case with the steam whistle, the air passes out with extreme rapidity, and without any obstruction. This whistle is placed within a tube in the form of a speaking-trumpet, which is directed towards the engine-man, and by merely turning the handle of the whistle, a powerful sound is produced, precisely similar to the steam whistle, and of an intensity which can be increased to any amount, by increasing the

pressure of the air in the receiver. The advantage of this plan of signals is, that it does not interfere with any of the other arrangements of the train, and is not dependent on any connexion with other parts of the train for its efficient operation.

The object sought to be obtained by Captain Taylor's proposition may we think be obtained by the improved Mouth Whistle, lately invented by Mr. Porteous, of which the annexed cut is a representation. It consists of a combination of any number of metallic tubular whistles, combined under one mouth-piece, and having their tones so arranged, that by the introduction of one discordant note, an extremely shrill vibrating sound is produced, which is conveyed to a great distance; its peculiar discordance enabling it to be distinguished from any other sound.



*Electric Telegraph.*—Amongst the numerous inventions to which railways have given rise, or have aided in bringing to maturity, the Electric Telegraph stands pre-eminent, transcending as far all previously known means of transmitting intelligence, as the railway exceeds all previously known methods of transport. The Semaphore or old telegraph, although capable of communicating with considerable celerity under favourable circumstances, might yet be deemed snail-paced in its action when compared with the electric telegraph, and from the lengths of the nights and the state of the atmosphere in this country, it was inefficient for three-fourths of the 24 hours on an average of the year: the electric telegraph, on the contrary, in addition to its action being so rapid as to defy calculation, and there-

fore being practically speaking *instantaneous*, is by night and by day, and under all circumstances of weather, constantly ready for instant use. Considered in connexion with railways, it affords to the latter advantages at least equivalent to that which it derives from them; for if railways from their security from intrusion afford the most favourable situations for the establishment of these telegraphs, the latter, from the instantaneous notice which they are capable of giving of what is occurring at any point of the line, not only obviate to a great extent the chances of accident, or facilitate the remedy of their effects when they do take place, but in many situations, they render it practicable to employ a single line of rails for a double line, and, by the economy thus effected, are calculated to add greatly to the extension of railways.

The idea of an electric telegraph is not so recent as is generally supposed, but it was not until the discovery of the connexion between electricity and magnetism that it was found reducible to practice, and for this discovery we are indebted to Professor Oersted, of Copenhagen, who first suspecting it in 1806, at length succeeded in proving it in 1819. The facts upon which the action of the electro-magnetic telegraph in its various modifications depends, are the following:—

1st. If a magnetic needle be brought near a wire, the ends of which are in contact with the poles of a galvanic battery, the needle will be deflected from its magnetic position, turning to the right or left, according to the course of the electric current.

2d. If a wire carrying an electric current be coiled many times round a soft bar of iron, a powerful magnetism is developed in the iron. This magnetism however continues only so long as the electric current continues to pass, the iron becoming instantly demagnetised on the current being interrupted. Thus, if round a bar of iron a long copper wire be wound, (the wire being coated throughout its entire length with some non-conducting substance, in order to

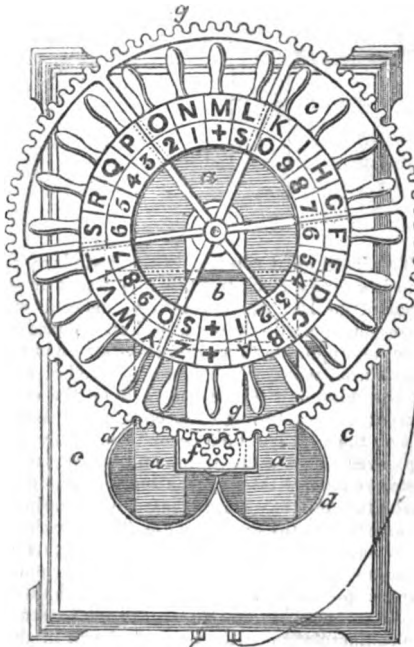
prevent metallic contact between the coil,) upon the ends of the wire being brought in contact the one with the positive, and the other with the negative pole of a galvanic battery, the iron becomes powerfully magnetic, attracting with great force any pieces of iron presented to it. On removing the wire from the battery the iron becomes demagnetised, and so rapidly does this magnetising and demagnetising process go on, that if the bar of iron be miles distant from the battery, and the connexion and interruption of the current be repeated with the utmost activity, a corresponding electric or non-electric state instantly appears in the distant iron bar.

The third fact (which may be considered as the converse of the second) is, that if a wire be moved near a magnet, an electric current is induced by the magnet in the wire, and by using a powerful magnet, and large coils of wire, very powerful electric currents are produced. We shall now proceed to describe three modifications of the electric telegraph, based upon the preceding facts, which have been, or are at present, in use. We commence with one or two telegraphic arrangements, invented by Messrs. Cooke and Wheatstone, employed on the Great Western railway, between the Paddington terminus and the station at Slough.

This arrangement comprises two distinct parts, namely, the "Communicator," which is stationed at that end of the line from which the message is transmitted, and the "Indicator," on which the message is read off, which is situated at the opposite end of the line, the two being connected by wires extending the whole distance between the two stations. Fig. 1 represents a plan of the communicator.

Fig. 1.

*a a* is a powerful horse-shoe magnet, supported on blocks of wood *b b*, secured to the wooden frame *c*. *d d* are two extensive coils of copper wire, covered with silk and varnished. The coils are supported on a forked bar of soft iron, attached to a vertical axis. The axis is turned by a pinion *f* on its end, which engages with the large toothed wheel *g*. The face of this wheel is divided into 24 compartments, one of which is marked with a cross, to indicate the starting and finishing point, and the remainder of the divisions are each marked with a letter of the alphabet, the letters *J U* and *X* being omitted. The number of teeth in this wheel is such that there occurs between each letter as many teeth as there are teeth in the pinion, so that in moving the wheel through an arc equal to one compartment or division, the pinion performs one revolution; and as the electric current produced in the coils when rotating occurs in only one position, (that is, when the forked bar of soft iron, upon which they are placed, is in contact with the under side of the magnets,) and in any other position they are non-electric, at each revolution of the coils a current of electricity through the wires will be once established and once broken; and in like manner, in turning the

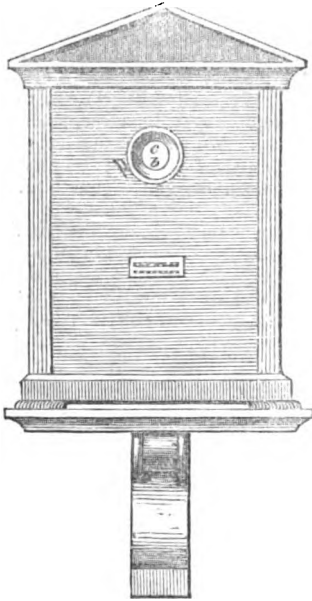




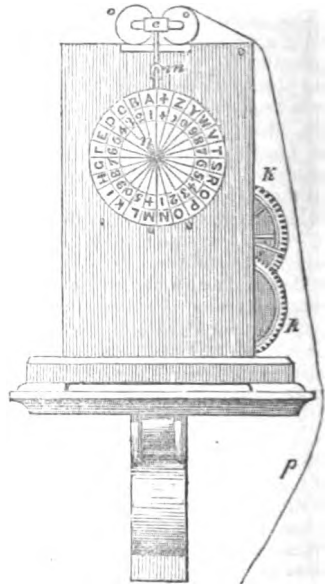
wheel through the space of ten letters there would be ten electric currents through the wires, and ten interruptions.

We must now proceed to the description of the "Indicator," represented in Figures 2 and 3; *Fig. 2* being an external elevation, and *Fig. 3* showing the apparatus divested of the external casing.

*Fig. 2.*



*Fig. 3.*



This instrument consists, in the first place, of a spring barrel and a train of wheels *k*, like a clock train, with a detent or escapement *m*, and having on the arbor of the last wheel a card *n*, marked with the letters of the alphabet, corresponding with those marked on the face of the communicator. Above the train, and opposite to an iron lever attached to the detent, is fixed a curved bar of soft iron, round which is wound a coil of covered wire *o*, which is connected by the wire *p* with the coils *d d* of the communicator; so that an electric current passing through the coils *d d*, passes at the same instant through the coil *o*; the iron bar then becomes instantly a powerful magnet, and attracting the lever releases the train, and allows the main arbor, with its card or dial plate, to revolve through the space of one division each time that the current passes through the wire. In the face of the casing which encloses the apparatus is cut an aperture *g*, (as shown in *Fig. 3*,) through which may be seen the uppermost letter and numeral on the dial card, and this card is so fixed on the arbor, that when any letter on the communicator is opposite to the pinion, that letter will stand uppermost on the dial, and appears through the aperture in the casing.

We will now suppose we wish to spell some word at the indicator, and suppose the communicator in the position shown in the drawing. Opposite the pinion of the communicator is the cross  $+$  and opposite to the hole in the indicator will also be the cross  $+$ . Let the word be "art":—if we turn the wheel of the communicator until the letter *a* is brought opposite the pinion, the coils will have rotated once, and a current running through the whole length of the wire, the wheel of the indicator will move through a tooth, and expose the letter *a*: we now turn the wheel until the letter *r* comes opposite the pinion, the coils

will then be made to rotate as many times as there are letters between *a* and *r*, that is sixteen times, and sixteen currents will have passed through the wires, and the wheel of the indicator will have turned through sixteen teeth, and the letter *r* be exposed. We now want letter *t*, and the letter *r* being opposite the pinion, we have only to move the toothed wheel through the distance of two letters to bring *t* to the aperture in the indicator; by thus moving it, two currents pass along the wires, and the indicator wheel passes round through the distance of two teeth, and the letter *t* is presented. It is obvious that in turning round the wheel of the communicator so as to bring opposite the pinion a distant letter, all the intermediate letters pass the pinion, and by the number of currents produced all the intermediate letters have passed before the opening in the indicator, but they pass so rapidly as not to be distinguishable, and no letter will rest opposite the hole but the proper one.

The telegraphic arrangement which we have just described, although perhaps the most simple in principle, and the most readily comprehensible in its operation, is not that which is most generally employed in this country; being deemed, upon the whole, inferior to that arrangement which is based upon the deflection of magnetic needles by the agency of electric currents, and which we shall now proceed to describe.

Fig. 1.

Fig. 2.

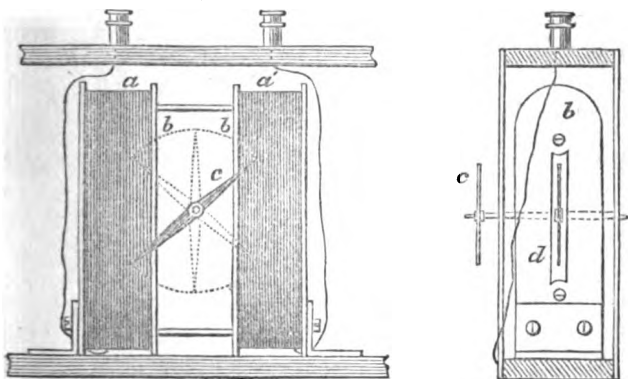
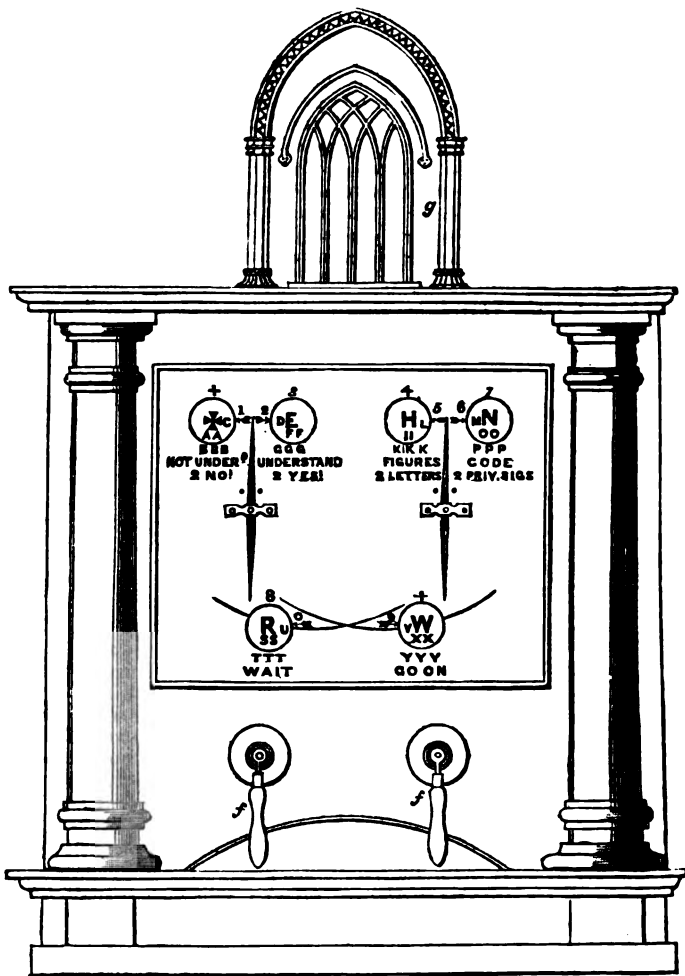


Fig. 1 and 2 represent the electro-magnetic portion of the apparatus, Fig. 1 being a front view, and Fig. 2 a transverse section. *a a'* are two coils of covered wire wound round a brass frame *b b*, which is bolted to the bottom of the case in which the apparatus is concealed; *c c* are two magnetic needles fixed upon an axis *d*, which turns in bearings fixed to the back and front of the case. One of the needles is placed upon the middle of the axis between the coils of wire, slits *d* being formed in the frames *b* to admit of the vibration; the other needle is fixed upon the end of the axis, which projects beyond the face of the instrument. The needles are fixed upon the axis with their respective poles standing in opposite directions; that is to say, the north pole of the one needle, and the south pole of the other, points upwards, so as to counteract the effects of the dip of the needle. Upon passing an electric current through the coils, by connecting them with a galvanic battery, they immediately exert a deflective force upon the needles, attracting them to the right or left, according to the course of the electric current, which always flows from the positive to the negative pole of the battery; thus, if the coil *a'* be connected with the positive or silver pole of the battery, the upper end of the needle will point to the right; but if the coil *a* be connected with the positive pole, the needle will point to the left. In the complete apparatus, two needles or pointers with their separate coils of wire are employed, and the letters of the alphabet, numerals, and a variety of conventional signals, are indicated by the single or combined movements of the needle on the face of a dial plate fixed in the front of the case in which the apparatus is enclosed, and which is shown in Fig. 3.

The indications of the various movements of the needles are as follows.

The left hand needle moving once to the left indicates the +, which is given at the end of a word ; twice in the same way, a ; thrice, s ; first right, then left,

Fig. 3.



c ; the reverse, d ; once direct to the right, e ; twice, f ; thrice, g ; and in the same order with the other needle for H, I, K, L, M, N, O, P.

The signals below the centre of the dial are indicated by the parallel movements of both needles simultaneously. Both needles moving once to the left indicate a ; twice, s ; thrice, r ; first right than left with both, u ; the reverse, v ; both moving once to the right, w ; twice, x ; thrice, y.

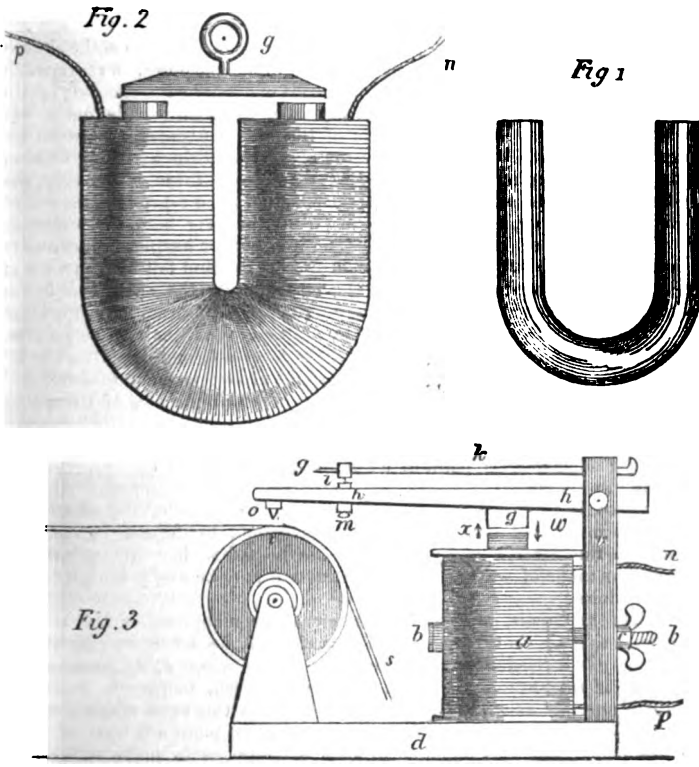
The figures are indicated in the same way as the letters nearest to which they are respectively placed.

To change from letters to figures, the operator gives H, followed by the + which the recipient returns to signify that he understands.

If after the above signs (H and +), were given, c, x, H, L, were received, 1845 would be understood.

A change from figures to letters is notified by giving I followed by the +, which the recipient also returns.

Each word is acknowledged; if the recipient understands, he gives x, if not the +, in which case the word is repeated. Stops are placed at x x, to limit the range of the vibrations of the needles. The connexion between the needles and the battery is made and broken by means of the handles *f f*. Within the case *g* is contained an alarm, which is rung to give notice to the person stationed at the other end of the line, that a communication is about to be made. This is effected in a similar way to that by which the indicator in the first described telegraph is set in motion; opposite the lever of the detent is fixed a horseshoe bar of soft iron, round which is coiled a quantity of wire, which, when connected with a wire from a battery, becomes a powerful magnet, and attracting the detent lever releases the spring, and thereby sets the alarm in motion. A similar warning apparatus is attached to the first described telegraph.



A third arrangement of the electric telegraph is that invented by Professor Morse, and which is the one adopted in America.

The electro-magnet is the basis upon which this invention wholly rests in its present construction. The electro-magnet is produced by coiling around a bar of soft iron made in the form of a horseshoe (*Fig. 1.*) copper wire previously covered, (similar to bonnet wire,) and varnished to prevent metallic contact with

each other and the iron (*Fig. 2*). The two terminations of the wire thus surrounding the iron in a spiral form, are brought out at each end of the curved bar, and are connected one with the zinc pole of a galvanic battery, the other with the platinum pole. The battery being prepared in the usual manner with its corroding acid, produces galvanic electricity, which starts off from one pole of the battery, follows the wire around the soft iron, and returns to the other pole of the battery by the other wire, thus forming a complete circuit. The galvanic fluid is now passing the whole length of the wire, and while thus passing, the curved iron becomes a strong magnet. By connecting the two ends of the bent iron with a bar of similar soft iron, it will support many pounds weight. If while in this condition one of the wires is removed from the battery, the cross bar falls, and with it its weights, and the curved iron returns instantly to its original state. It is unmagnetized. Complete the circuit, as at first, and in an instant it is again a magnet. If the battery is placed 100, or 1000, or 10,000 feet from the iron, yet when the one is connected with the other by intervening wires, the effect upon the magnet is the same, making it a magnet when the circuit is complete, and *vice versâ* when it is broken. In this way power is produced at a point of considerable distance from the generating agent; and it is wholly at the command of the operator at the battery to make or destroy the power produced with the utmost possible rapidity.

The figures on the preceding page represent the most simple form of the electro-magnet, with its appropriate machinery for telegraphic purposes. *a* represents a side view of an iron bar, surrounded with its coils of copper wire, standing upon a platform *d*; *v* being an upright arm secured to *d*, to which the magnet or soft iron is permanently fastened, by means of the bolt *b b* passing between the prongs of the curved iron, and through the board *v*, and the adjusting screw *c*. *e* is the projecting prong of the iron after it has passed through the coils, one only being seen. The other prong is directly behind *e*. *g* represents the end of the iron bar or keeper, extending back so far as to cover both the projecting ends of the horseshoe-formed magnet. The iron bar, or keeper, is fastened to the lever *h h*, which is delicately adjusted so as to rise and fall by a pivot at *i*; *k* represents a steel spring, supported at one end over the lever *h h* by the upright *v*, and passing through a loop *l* formed from a brass wire, the lower part of the brass wire being secured to the lever *h* by means of a screw at *m*. *o* is a hardened steel point, connected with the lever *h h*, and directly over the centre of the metallic roller *t*, in which a slight groove is made to correspond with the point of *o*. *r* represents the standard in which the axis of the roller *t* freely revolves.

The line *s* represents the paper in form of a riband passing from its coil between the roller and the point of *o*; *n* and *p* are the two extremities of the wire upon the magnet *a*.

Every part is now described, and from what has preceded the description, (bearing in mind that the battery, when in action, by forming a complete circuit with the wires *n* and *p*, converts the horseshoe bar into a powerful magnet,) the mode of writing by the instrument may be easily comprehended by what follows.

Complete the circuit, and instantly the cross bar *g* approaches the ends of the magnet *e*, until they meet in the direction of the arrow *w*. Break the circuit, and *g* is carried up in the direction of the arrow *x*, by means of the spring *k*. If to the roller *t* clock work is attached, to give it a uniform movement upon its axis, the paper *s* will move with the same uniform motion under the point *o*, then by completing the circuit the point *o* is brought down upon the paper, which is indented to such a degree as to make it perfectly apparent, and the point continues to mark it in that manner so long as the circuit is closed, but, upon breaking the circuit, the marking ceases, and the point *o* flies from the paper, which continues passing on.

If the circuit is closed and broken with the utmost rapidity, then a succession of dots and of spaces upon the paper appears.

If the circuit is successively closed and broken with less rapidity, short lines and intervening short spaces are made. If closed for a longer time, and broken

in succession, then the marks become longer: so that dots, short lines, long lines, and short and long spaces, are made according to the time the circuit is closed, and the rapidity with which the paper moves under the pen.

An arbitrary arrangement of these dots, short and long spaces, and lines, constitutes the telegraphic alphabet, by means of which, intelligence to any extent is communicated. Thus one dot may represent *a*, two dots *b*, three dots *c*, one dot and a line *d*, &c. The paper to be imprinted, is fixed upon a revolving cylinder, and records despatches day and night; the records of the night may be examined in the morning. The alphabet is easily learned.

*Safeguard against Collisions.*—Figures 5 and 6 represent an apparatus invented by Mr. Curtis for the prevention of collisions on Railways.

*Fig. 5* is a side view of the apparatus, and an engine in contact with it, attached to the last carriage of a train, and *Fig. 6* is a plan of the same.

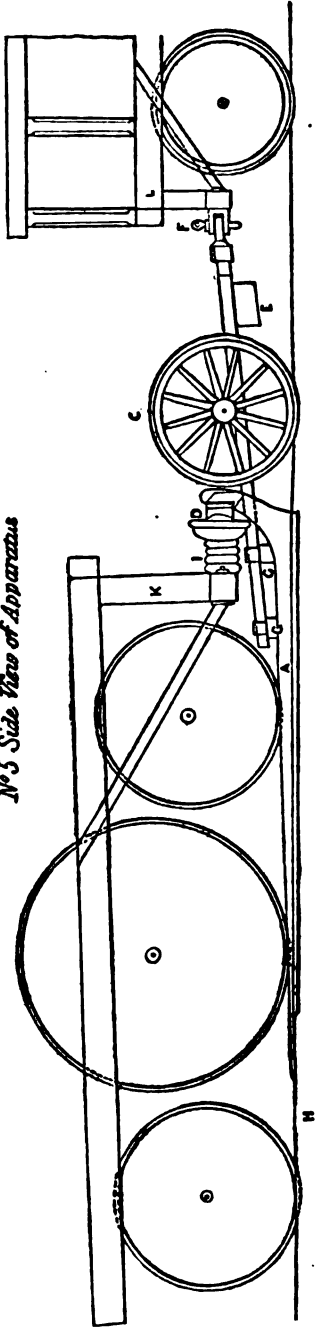
The sledge or retarder *A* is formed like a wedge, with its superior end turned up; upon the inner side, flanges are formed, so as to keep it upon the rails; the two sides are united together by the cross bar *J*, the plate *K*, and the cross pieces *Q Q*, and the sides are set to the same gauge as the rails, so that an engine may run upon it without difficulty; to the cross bar *J*, two buffers *D D* are fixed, which correspond with other buffers *I*, formed upon the front frame of the engine, so that when the engine comes in contact with the retarder, these buffers receive the concussion; the plate *K* is used in order to unite the sledge as near to the point as possible, and still to allow a free passage to the flanges of the wheels. To the cross pieces *Q Q* the spring pieces *B B* are fixed, forming shafts for the wheels *C C*, upon which the apparatus is carried when out of gear. *E* is a weight to counterpoise the weight of the sledge, so that a man can move it along the line like a truck with great facility. The coupling *F* is formed for the purpose of connecting the sledge with the train in the usual way, by means of a joint and pin.

The retarder when out of action, and connected with a train, is attached, to the last carriage as shown at *L*; the sledge then rides above the rails, and is suspended by the spring pieces *B B*; but should an accident happen which would stop the train, one of the conductors immediately detaches the retarder, and runs back with it, and places it 500 or 600 yards behind the broken down train; then should the engineer of the following train not observe the train before him, and stop his engine, the engine would run into the retarder, and would become a sledge, and the driving wheels, if not stopped by the great resistance which would now be opposed to them, would skid round in the retarder and would have no power to move forwards. No violent concussion would take place, but the engine would slide along a certain distance in the retarder, when the train would be brought to a stand-still. A hanging frame *K* must be formed from the engine frame, and the buffers usually placed upon the head board must be transferred to the lower frames, or other buffers *I* be placed there.

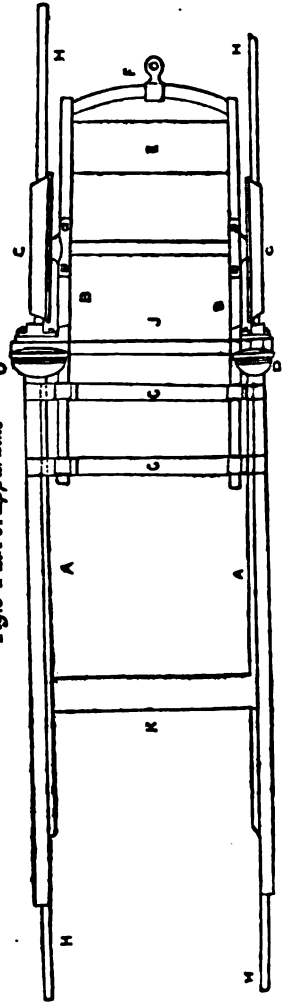
In the case of a swift train overtaking another train in a fog, or at night, the swift engine would run into the retarder, and the same effect upon the engine and train would be produced as before stated; viz. that it would be brought to a stand; and the only effect produced to the slow train behind which the retarder was travelling, would be, that it would be torn away from its fastenings; for the purpose therefore of a case of this nature it will be advisable to make the fastenings such that it may be torn away without the last carriage being subjected to any violent shock; with this view the pin at *F* may be of oak or hard wood, strong enough to drag the retarder, but sufficiently weak to give way in the case mentioned.

AN APPARATUS TO PREVENT COLLISION BETWEEN TRAINS ON RAILWAYS

*No 5 Side View of Apparatus*



*No 6 Plan of Apparatus*



## SECTION VI.

### CHRONOLOGICAL AND DESCRIPTIVE LIST OF ALL PATENTS GRANTED FOR IMPROVEMENTS IN RAILWAYS, AND LOCOMOTION THEREON:

*down to the 30th June, 1846.*

---

NOTE.—Further information respecting these Patents may be obtained at J. Murdoch's British and Foreign Patent Office, 7, Staple Inn, Holborn, London.

---

*24th March, 1802.* R. Trevithick and A. Vivian. For methods of improving the construction of steam engines, and the application thereof for driving carriages and for other purposes.—Described at page 379.

*28th Feb. 1803.* J. Woodhouse. For a new method of forming a cast iron rail or plate, which may be used in making iron railroads, or ways for the working and running of waggons, carts, drays, and other carriages on public and other roads, and also a new method of fixing, fastening, and securing such cast iron rail or plate on such roads.

Rails formed as hollow quadrangular blocks of cast iron, concave on their upper surface.—Described further at page 380.

*10th April, 1811.* J. Blenkinsop. Certain mechanical means by which the conveyance of coals, minerals, and other articles is facilitated, and the expense attending the same is rendered less than heretofore.—Described at page 382.

*30th Dec. 1812.* W. and E. W. Chapman. For a method or methods of facilitating the means, and reducing the expense, of carriages, on railways and other roads.—Described at page 384.

*22d May, 1813.* W. Brunton. A method and machinery for propelling or drawing carriages upon roads or railways.—Described at page 385.

*28th Feb. 1815.* R. Dodd and G. Stephenson. For various improvements in the construction of locomotive engines.—Described at page 386.

*18th Nov. 1815.* Jos. Baader. For an improved plan of constructing railroads, and carriages to be used on such improved railroads; for the more easy, convenient, and expeditious conveyance of all sorts of goods, wares, merchandise, persons, and all other articles usually, or at any time, removed in carriages of any construction whatever.

*30th Sept. 1816.* W. Losh and G. Stephenson. For a method or methods of facilitating the conveyance of carriages, and all manner of goods and materials along railways and frameways, by certain inventions and improvements in the construction of the machine carriages, carriage wheels, railways and frameways employed for that purpose.

Improvements in the construction of edge rails and tram plates, and in the mode of supporting them and connecting them to each other; also in the employing steam cylinders to support the body of the locomotive, and forming railway wheels with wrought iron tires and cast iron spokes, or *vice versa*.—See further pages 387 and 389.

*5th Aug. 1817.* J. Hawks. For a method of making iron rails, to be used in the construction of railways.

The upper side of the rail is formed of cast iron, and the lower or under side of wrought iron, which is inserted into the former during the casting.—See further page 391.

*23d Oct. 1820.* J. Birkenshaw. Certain improvements in the manufacturing and construction of a wrought or malleable iron railroad or way.



Making wrought iron rails of a prismatic or wedge form.—See further page 392.

14th Sept. 1821. W. Losh. Certain improvements in the construction of iron rails for railways.

The improvements consist, first, in fixing bars of malleable iron on the upper surface of a line of cast iron rails, or wrought iron rails, so as to form an uninterrupted line the whole length of the bar; Secondly, fixing a strap of wrought iron to the under side of a cast iron rail; Thirdly, uniting two wrought iron ribs or sides to a third plate of wrought iron to form a rail.—See further page 393.

24th Oct. 1821. B. Thompson. Method of facilitating the conveyance of carriages along iron and wood railways, tramways, and other roads.

22d Nov. 1821. H. R. Palmer. Improvements in the construction of railways and tramroads, and of the carriage or carriages to be used thereon.—Described at page 394.

19th Feb. 1824. John Vallance. For producing locomotion by stationary engines.—Described at page 486.

28th Feb. 1824. W. James. Certain improvements in the construction of rail and tramroads, or ways, which rail tramroads or ways are applicable to other useful purposes.

Railways formed of cast iron tubes, having flat tops for the carriage wheels of a train to run upon; the hollow space within being designed for the conveyance of water, to supply water to work machinery by its descent. The patentee also proposed to *impel* the carriages of a train by these conduits, by causing the water to act upon drums.

18th Dec. 1824. W. F. Snowden. For a wheel way and its carriage or carriages, for the conveyance of passengers, merchandize, and other things, along roads, rails, and other ways, either on a level or inclined plane, and applicable to other purposes.—Described at page 396.

5th March, 1825. W. H. James. Improvements on railways and in the construction of carriages to be employed thereon.—Described at page 399.

2d April, 1825. Jacob J. Fisher. New application of railways, and the machinery to be employed thereon.—Described at page 400.

12th April, 1825. R. W. Brandling. Certain improvements in the construction of railroads, and in the construction of carriages to be employed thereon, and elsewhere.—Described at page 401.

10th May, 1825. T. Hill. Certain improvements in the construction of railways and tramroads, and in carriages to be used thereon, and on other roads.—Described at page 401.

14th Aug. 1827. Wm. Chapman. Certain improvement, or certain improvements in the construction of waggons that have to travel on railways, or on tramways.

The construction of framework underneath the body of the waggons, to connect the wheels together and allow them more vertical play, and afford a more equal bearing on the four wheels, in those parts of the railroad where the inequality of the level might cause them to bear upon three wheels only.

1st May, 1828. Jon. Brownhill. Improved methods of transferring vessels from a higher to a lower level, or from a lower to a higher level on canals, and also for the more conveniently raising and lowering of weights, carriages, or goods on railroads, and for other purposes.

18th Sept. 1828. W. Losh. Certain improvements in the formation of iron rails for railroads, and of the chains or pedestals, in or upon which the rails may be placed or fixed.—Described at page 413.

21st May, 1829. M. Dick. Improved railroad and method of propelling carriages thereon by machinery, for the purpose of conveying passengers, letters, intelligence, packets and other goods with great velocity.—Described at page 401.

31st Aug. 1830. W. Losh. Improvements in wheels for railway carriages.—Described at page 471.

7th Sept. 1830. C. B. Vignoles, and J. Ericsson. Certain additions to locomotive engines.—Described at page 467.

*21st Feb.* 1831. J. Grime. Certain methods of dissolving snow or ice, on the trams or railways, in order that locomotive engines and carriages and other carriages may pass over railroads without any obstruction, or impediment, from such snow or ice.—Described at page 445.

*11th March,* 1831. Robert Stephenson. For an improvement in the axles and parts which form the bearings at the centres of wheels for carriages, which are to travel upon railways.—Described at page 470.

*30th April,* 1831. George Stephenson. For an improved mode of making wheels for locomotive carriages. The improvement consists in the substitution of hollow tubes of wrought iron, instead of solid bars, for the spokes of the wheels; the application of a preparation of borax, as a flux to the ends of such tubular spokes, previously to placing them in the sand mould; and then of running the cast metal around them to form the felloes and the nave.

*5th Sept.* 1831. George Forrester. For certain improvements in wheels for carriages and machinery, which improvements are applicable to other purposes.

*13th April* 1832. R. Roberts. Certain improvement, or certain improvements in steam engines, and also in the mechanism through which the elastic force of steam is made to give impulse to, and regulate, the speed of locomotive carriages.

*29th June,* 1832. J. Macdonald. Improvements in the construction of railways.

*18th Sept.* 1832. R. Badnall. Improvements in the construction of the trams or rails or lines of tramroads, upon which locomotive engines shall or may be worked.—Described at page 513.

*6th Nov.* 1832. H. Scrivener. For certain improvements in the construction of iron railways.—Described at page 417.

*20th Dec.* 1832. Jos. Saxton. Certain improvements in propelling carriages, and in propelling vessels for inland navigation.—Described at page 510.

*26th Jan.* 1833. R. Stephenson. Certain improvements in the locomotive steam engine, now in use for the quick conveyance of goods and passengers upon edge railroads.

*1st June,* 1833. Wm. Jessop. Certain improvements in the construction of railways.—Described at page 414.

*10th June,* 1833. R. Smith and J. Walkinshaw. Improved rail for railroads.

*29th June,* 1833. Jos. Gibbs and A. Applegath. Improvements in the construction of railroads, bridges, piers, jetties, and aqueducts, part of which may be applied to other useful purposes.

*7th Oct.* 1833. R. Stephenson. Certain improvements in the locomotive steam engine now in use for the quick conveyance of passengers and goods upon edge railroads.

Forming driving wheels (of six wheeled locomotives) with plain tires, *i. e.* without flanges, and a peculiarly constructed brake, set in action by a small steam engine.—See further page 449.

*11th Dec.* 1833. R. Stephenson. Improvements in the mode of supporting the iron rails for edge railroads.—Described at page 415.

*1st March,* 1834. H. Pinkus. Improved method of, or apparatus for, communicating and transmitting, or extending motive power, by means whereof carriages or waggons may be propelled on railways, or common roads, and vessels may be propelled on canals.—Described at page 487.

*8th Oct.* 1834. B. Hick. Certain improvements in the locomotive steam carriages, parts of which improvements are applicable to ordinary carriages and to steam engines employed for other uses.—Described at page 483.

*20th Nov.* 1834. R. Whiteside. Certain improvements in the wheels of steam carriages, and in the machinery for propelling the same, also applicable to other purposes.

*22d Jan.* 1835. J. Day. Improvement or improvements in the construction of railways.

*16th Feb.* 1835. J. Price. Certain improvements in railways, and in the means of transporting carriages from one level to another.

*4th March, 1835.* T. F. Bergin. Improvements in railway carriages, which improvements are applicable to other purposes.—Described at page 475.

*5th May, 1835.* J. Reynolds. Certain improvements in railways.—Described at page 419.

*10th Aug. 1835.* S. W. Nicholl. Certain improvements in rendering steam engines portable, and applicable as a means of general transport on rail and other roads.

*17th Aug. 1835.* H. Pinkus. Improvements in inland transit, which improvements are applicable to and may be combined with an improved method of, or combination of methods and apparatus for communicating and transmitting or extending motive power, by means whereof carriages or waggons may be propelled on railways or roads, and vessels may be propelled on canals.—Described at page 487.

*3d Dec. 1835.* T. Parkin. Improvements in sleepers or bearers applicable to railways.—Described at page 420.

*16th Dec. 1835.* H. Booth. Improved method of attaching railway carriages together, for the purpose of obtaining steadiness and smoothness of motion.—Described at page 482.

*23d Jan. 1836.* H. Booth. Improvements applicable to locomotive steam engines, and railway carriages.

*23d April, 1836.* G. A. Kollman. Improvements in railways, and in locomotive carriages.—Described at page 468.

*23d April, 1836.* E. J. Massey. Improvements in railway and other locomotive carriages.

*17th May, 1836.* H. W. Wood. Certain improvements in certain locomotive apparatus.

*18th May, 1836.* P. B. G. Debac. Improvements in railways.

*6th Aug. 1836.* T. Binns. Improvements in railways, and in the steam engines to be used thereon, and for other purposes.

*4th Oct. 1836.* J. White. Certain improvements on railways.

*13th Oct. 1836.* J. Ruthven. Improvements in the formation of rails or rods for making railways, and in the method of fixing or joining them.

*8th Nov. 1836.* J. E. Smith. Improvements in railways, and in locomotive carriages to work on such railways.

*3d Dec. 1836.* H. Booth. Improvements in the construction and arrangement of railway tunnels, to be worked by locomotive engines.

*9th Dec. 1836.* J. Yates. Improvements in tramroads or railroads, and in the wheels, or other parts of carriages to be worked thereon.

*15th Dec. 1836.* J. Melling. Certain improvements in locomotive steam engines to be used upon railways or other roads, part or parts of which improvements are also applicable to stationary steam engines, and to machinery in general.

*25th April, 1837.* J. Pim, and T. F. Bergin. For an improved means or method of propulsion on railways.

Certain peculiar arrangements for applying manumotive power to propelling carriages on railways.

*4th April, 1837.* H. Booth. Improvements in the construction of locomotive engines, boilers, and furnaces, also to other furnaces.

*13th May, 1837.* P. B. G. Debac. Improvements applicable to railroads.

*26th July, 1837.* J. Melling. Improvements in locomotive steam engines, to be used upon railways, parts of which improvements are applicable to stationary steam engines, and to machinery in general.—Described at page 425.

*25th Nov. 1837.* H. P. Vaile. Improvements in rails for railroads.

*19th Dec. 1837.* E. B. Rowley. Certain improvements applicable to locomotive engines, tenders, and carriages, to be used upon railroads, and which improvements are also applicable to other useful purposes.

*4th Jan. 1838.* N. Worsdell. Improvements in apparatus to facilitate the conveyance of mail bags, and other parcels on railways or roads.

Apparatus for receiving and delivering railway bags and parcels, along a line of railway, at places intermediate between the stations, without stopping

the train. The bags to be delivered are suspended by their loop from two pins in a bar projecting from the carriage, from which bar also projects a prong or hook, and the bags to be received from the post house are suspended from a similar apparatus, attached to a lamp post. By passage of the carriage past the lamp post, the hook on the latter passes through the loop of the carriage bags, and bears them off the pins, and the hook on the carriage in like manner carries off the post house bags.

*8th Feb.* 1838. J. Deville. Certain improvements in railroads, and in the carriages to be used thereon.

*10th March,* 1838. T. Evans. Improved rail for railway purposes, together with the mode of manufacturing and fastening down the same.

*18th June,* 1838. J. White. Certain improvements in the construction of railroads, bridges, and viaducts.

*10th Aug.* 1838. E. de Beuret. Certain improvements in the construction of railroads and tramroads, to facilitate the ascent and descent of hills and inclined planes.

*15th Aug.* 1838. C. Fox. Improved arrangement of rails for the purpose of causing a railroad engine, carriage, or train, to pass from one rail to another.

*25th Aug.* 1838. J. C. Hadden. Certain improvements in the construction of carriages to be used on railways, and in the method of forming the same into trains.

*31st Aug.* 1838. J. Curtis. Certain improved machinery and apparatus, for facilitation of travelling, and transport on railways, parts of which are applicable to other purposes.—Described at page 428.

*13th Sept.* 1838. T. Wilkinson. Certain improvements in the construction of tram or railways, and in the carriages to be used thereon.

*3d Nov.* 1838. J. Deville. Improvements in railroads, and in carriages thereon.

*17th Dec.* 1838. J. Hawkshaw. Certain improvements in mechanism, or apparatus applicable to railways, and also to carriages to be used thereon.—Described at page 525.

*22d May,* 1839. T. Harper. Certain improvements in railways or tramroads.

*17th Aug.* 1839. G. A. Kollman. Improvements in railways, and in locomotive and other carriages. Described at page 468

*21st Nov.* 1839. J. Faram. Certain improvements in the mode of constructing, applying, and using railway switches, for connecting different lines of railway, or two distant railways, and for passing locomotive steam and other engines, and railway carriages and waggons, from the one to the other of such railways, and for certain apparatus connected therewith.

*4th Dec.* 1839. C. Nickels. Improvements in propelling carriages.

*4th Dec.* 1839. J. Nasmyth. Certain improvements applicable to railway carriages.

Employing the momentum of the train to bring the train to rest by connecting the spindles, or stems of the buffers, to the brake levers, which are brought down by the buffers being forced in.

*3d March,* 1840. J. Rangeley. Improvements in the construction of railways, and in the means of applying power to propel carriages, and machinery.

*12th May,* 1840. H. Dircks. Certain improvements in the construction of locomotive steam engines, and in wheels to be used on rail and other ways, parts of which improvements are applicable to steam engines generally.

1 Consumption of smoke in locomotives where coal is used for fuel.

2. Forming wheels of iron with a channel in the periphery, filled up with blocks of wood placed with the grain standing radially.—See further page 473.

*28th May,* 1840. D. Gooch. Certain improvements in wheels and locomotive engines to be used on railways.

*28th May,* 1840. W. H. Smith. Improvement or improvements in the mode of resisting shocks to railway carriages and trains, and also in the mode of connecting and disconnecting railway carriages; also in the application of springs to carriages.

30th May, 1840. W. Pettit. For a communicating apparatus, to be applied to railroad carriages.

9th June, 1840. J. G. Shuttleworth. Certain improvements in railway and other propulsion. A mode of propelling by hydraulic pressure.

7th Aug. 1840. A. Smith. Certain improvements in carriages, rails, and chairs for railways.

The tires of the wheels are formed with a rectangular groove on the periphery, instead of a flange on the side. The rails are square bars of iron, let into grooves cut in wooden sleepers, with one of the angles upwards, and the chairs clip the sides of the rails in a dove-tail form.

10th Sept. 1840. Henry Houldsworth. Improvements in carriages, and for the conveyance of passengers on railways, and an improved seat applicable to such carriages and other purposes.

Application of wire gauze to carriages, to exclude dust, &c, and to break the violence of the current of air in rapid travelling, without materially obstructing the view of external objects, also seats which fold up of themselves when not in use.

22d Sept. 1840. T. Paine. For a plan by means of which carriages may be propelled by atmospheric pressure, only without the assistance of any other power, being an improvement on the atmospheric railways now in use.

15th Oct. 1840. R. Pettit. Improvements in railroads, and in the carriage and wheels used thereon.

1. Forming the wheels without flanges, and retaining them on the rails by means of horizontal wheels pressing against the inner side of the bearing rail, or against a centre rail.

2. An improved brake to be worked by hand.

3. A self-acting apparatus to be attached to railway engines, which shall cut off the steam, sound the alarm, and bring down the brake.

2d Nov. 1840. E. Galloway. Improvements in propelling railroad carriages.

2d Nov. 1840. J. Boydell. Improvements in working railways and other carriages, in order to stop them, and also to prevent them running off the lines or rails.

A brake lined with wood clips the rail, to stop the carriages, and bars extended below the carriages from opposite corners, to retain the carriages on the rail.

12th Nov. 1840. E. Birch. Improvements applicable to railroads, and to the engine and carriages to be worked thereon.

Self-acting brake, whistle, and signal apparatus.

24th Nov. 1840. F. Pope. Improvements in detaching locomotive and other carriages.

The shafts in common carriages, and the drag link in locomotives, are connected to a tongue held down by a spring catch, to which a lever is affixed: on pulling the lever, the catch is disengaged, the tongue flies over, and the horse or locomotive is released.

24th Nov. 1840. J. Haughton. Improvements in the means employed in preventing railway accidents, resulting from one train overtaking another.

A mode of employing a time-keeper, suitably acted upon by each passing train, to show the time which has expired between the passing of one train and the coming up of another, and also to register the time of each train passing.

16th Dec. 1840. J. Beathie. Certain improvements in locomotive engines, and in chairs and wheels for use upon railways, and certain machinery for use in the construction of parts of such inventions.

Apparatus for increasing the adhesion; improved buffing apparatus; brake with whistle attached, and coupling chain; improved railway chair; elastic wheels for railway carriages.

18th Dec. 1840. A. A. Lindo. Improvements to be applied to railways and carriages; thereon, to prevent accidents, and to lessen the injurious effects of accidents to passengers, goods, and railway trains.

A self-acting whistle and governor; an apparatus for clearing the rails of obstructions; another for lifting men or animals off the rails; an apparatus to

prevent carriages running off the rails, and to support them in the event of a wheel breaking; an improved buffer, and an improved mode of transmitting signals.

18th Dec. 1840. E. R. Handcock. Certain improvements in mechanism applicable to turn-tables for changing the position of carriages upon railroads, for furniture, and other purposes.

The turn-table is supported on a vertical spindle, round the upper and lower end of which are placed two loose collars, or anti-friction rollers, to diminish the lateral thrust of the socket, which is attached to the under side of the table.

—See further page 433.

23d. Dec. 1840. G. Thornton. Certain improvements applicable to railways, locomotive engines, and carriages.

These improvements are: a medium gauge of about 6 feet; a self-acting steam governor and water governor; preparatory heating of water in a case surrounding the smoke box; turning the waste steam into the chimney; cleaning out the fire tubes by a jet of steam and hot water; a self-acting brake for the wheels of the engine, and brakes to the carriages, which are raised by a drag rope from the engine, and descend upon the rope becoming slack.

7th May, 1840. H. M. Grover. Improved method of retarding and stopping railway carriages, and trains.

24th Sept. 1840. Henry Pinkus. Improvements in the methods of applying motive power to the impelling of machinery, applicable amongst other things to impelling carriages on railways, on common roads or ways, and through fields, and vessels afloat, and in the method of constructing the roads or ways on which carriages may be impelled or propelled.

Propelling by exploding gas, by electricity, and by what the patentee terms the gaso-pneumatic power.

6th Jan. 1841. Henry Bessemer. New mode of checking the speed of, or stopping, railway carriages under certain circumstances.

A self-acting brake, which is brought into immediate action upon any diminution of the regulated distance between the locomotive engine and the train of carriages, by the operation of compressed air.

14th Jan. 1841. W. Hancock. Certain improved means of preventing accidents on railways.

Brakes set in action by the pressure of steam in the boiler, self-acting switches, and a mode of signaling accidents, and the exact time of their occurrence.

19th Jan. 1841. R. B. Curtis. Method or methods of making signals by self-acting apparatus, to be used on railways, for the purpose of obviating collisions between successive trains.

A pointer upon a signal post is raised, and maintained at a certain height by a train of wheels, actuated by a weight, which is wound up once in 24 hours. The engine in passing detaches the pointer from the wheel work, and the pointer descends to the lowest point, but when the train is past, the wheel work again slowly elevates the pointer, and by the position of the pointer, the driver of the succeeding train can judge how far the preceding train is ahead of him.

28th Jan. 1841. W. Gall. Certain improvements in the construction of locomotive engines, and of the carriages used on railways, applicable in part to carriages used on common roads.

28th Jan. 1841. W. C. Harrison. Improved turning table for railway purposes.

An arrangement of anti-friction rollers round the central post which supports the table.

1st Feb. 1841. W. W. Taylor. Improvements in buffing apparatus for railway purposes.

Applying a series of layers of felt to the ordinary buffer head, or to a board extending across the whole breadth of the end of the carriage frame, and covering the felt with leather or other water-proof material.

3d Feb. 1841. J. Bunnett. Certain improvements in locomotive engines and carriages.

An improved steam regulator, five different sorts of brakes, and an axle-guard, which allows a compensating movement when the wheels are traversing curves.

*8th Feb.* 1841. E. Oldham. Certain improvements in the construction of turning tables, to be used on railways.

The table or platform is supported on a pivot at its centre, and assisted by stationary anti-friction rollers at the circumference.

*8th Feb.* 1841. J. Scott. Improvements in constructing railways, and in propelling carriages thereon, which improvements are applicable to raising and lowering weights.

A series of cog wheels placed at short intervals along the centre of the railway, and driven by stationary engines, give motion to the carriages by means of a rack attached to the under side of the carriages.

*15th Feb.* 1841. J. Ransom and C. May. Improvements in the manufacture of railway chains, railway or other pins or bolts, and in wood fastenings and handrails.

Casting railway chairs by means of metal side plates and metal cores in sand moulds. Forming wooden pins and wedges, by forcing them into metal moulds, and heating them whilst under compression, till the elasticity of the wood is sufficiently overcome. See further at page 421.

*22d March,* 1841. Thomas Wright. Certain improvements applicable to railway and other carriages.

Improvements in brakes, axle-trees and boxes, carriage springs, safety flanges on the outer edge of the ordinary flange on railway wheels, hollow steel spokes, and an elastic plate to serve as a brake, a sledge and a buffer.

*17th April,* 1841. P. Kendall. Improved method or methods of connecting and disconnecting locomotive engines and railway carriages.

The connecting link from the tender is received between two elastic metal plates, and a stud projecting from each side of the link, passes through holes in the ends of the plates, and so long as the pull is in a direct line, the link is firmly retained by the plates, but if the strain should become oblique to the elastic plates, the link is released.

*11th May,* 1841. E. Taylor. Certain improvements in the construction of carriages used on railroads.

Constructing the roofs and pannels of railway carriages of papier mâché; affixing to one wheel a solid axle, which revolves in a hollow axle affixed to the opposite wheel, and forming wheels with segments of wood or of papier mâché within the tire.

*20th May,* 1841. John Carr. Improvements in apparatus for retarding and stopping railway carriages.

Brakes moved by a screw acting upon an arrangement of levers.

*22d May,* 1841. Joseph Woods. Certain improvements in locomotive engines; and also for certain improvements in the machinery for the production of rotary motion for obtaining mechanical power, which improvements in machinery are also applicable for raising or impelling fluids.

Employing loose wheels on locomotives, in order to traverse curves more easily; improved lubricator; improved reversing gear; connecting a whistle to the blast pipe to give a constant intermittent whistle in a fog; improved swivel joints to the water pipe of the tender, and a rotatory disc engine.

*5th June,* 1841. J. Gibbs. Improvements in roads and in railways, and in the means of propelling carriages thereon.

A mode of propelling railway carriages by fixed engines.

*23d June,* 1841. R. Stephenson. Certain improvements in the arrangement and combination of the parts of steam engines, of the sort commonly called locomotive engines.

1. Lengthening the cylindrical portion of the boiler, so as to admit the three axles of six-wheeled engines to be placed beneath the cylindrical part of the boiler, and between the front of the fire-box and the back of the smoke-box.

2. Improvements in the slide valve and reversing the gear; and

3. Working the feed pumps by means of the eccentrics which are employed to cause the engine to run backwards along the rails.

28th July, 1841. A. B. Von Rathen. New method or methods, called by the inventor "The united stationary and locomotive system," of propelling locomotive carriages on railways and common roads, and vessels on rivers and canals, by the application of a power produced or obtained by means of machinery and apparatus unconnected with the carriages and vessels to be propelled.

9th Dec. 1841. J. Edwards. Improvements in giving signal on railways.

1. The using of a series of lamps for night signals, and by the different combinations of the lamps when exposed, or when closed, to communicate from a train of carriages to a station, or from a station to a train, or from one train to another.

2. The giving signals by day, by combining the use of a series of thin plates, presenting some edgeways and others flatways, and in combining in various ways.

16th Dec. 1841. C. E. Austin. Apparatus for what is commonly called changing the line of railways.

16th Dec. 1841. W. Prowett. Improvements in giving signals on railways.

A mode of communicating by signals to a passing train, of the time since the previous train passed; the apparatus by which this information is given being set in motion by each successive train as it passes by it, thus avoiding the probability of one train running into the preceding one, at night, or in foggy weather.

21st Dec. 1841. T. Wright and A. Bain. Improvements in applying electricity to control railway engines and carriages, to mark time, to give signals, and print intelligence, at distant places.

15th Feb. 1842. T. R. Crampton and J. C. Hadden. Improvements in engines and railway carriages.

6th April, 1842. J. G. S. Clarke. Improvements in supplying and regulating air to the furnaces of locomotive engines.

23d May, 1842. John Bishop. Improved construction of brake apparatus, applicable to railway carriages.

21st June, 1842. John Dickinson. Improvements in rotatory engines and boilers in stopping railway carriages, and in machinery for propelling vessels, part of which improvements are applicable to propelling air and gases.

16th July, 1842. R. Benton. Certain improvements in propelling, retarding, and stopping carriages on railroads.

3d Aug. 1842. John Lee. Improvements in wheels and axletrees, to be used on railways and in machinery, for stopping on, or preventing such carriages from running off railways, which improvements may also be applied to other carriages and machinery.

31st Aug. 1842. C. F. Giutard. Certain improvements in the construction of railways.

16th Sept. 1842. W. H. James. Certain improvements in railways, and in carriage ways, railway and other carriages, and in the mode of propelling the said carriages, parts of which improvements are applicable to the reduction of friction in other machines.

25th Nov. 1842. P. T. Ralli. Improvements in the construction of railway and other carriages, and in apparatus connected therewith.

3d Dec. 1842. C. H. Wild. Improved switch for railway purposes. Causing the moveable rails to move through certain different degrees of space (although actuated by one lever), so as to be perfectly in gauge, when opened for diverging lines, and quite safe.

22d Dec. 1842. James Morris. Improvements in locomotive and other steam engines.

Expansive slide valve.

29th Dec. 1842. Baron V. de Wydriff. Improvements in the construction of railways, and in wheels to run on railways, and in apparatus for clearing rails.

11th Jan. 1843. C. Bailey. Certain improved constructions of rails for tramways and railways.

26th Jan. 1843. F. M. Getrick and M. B. Tennant. Improvement in apparatus.



tus for preventing the engines and carriages from going off the line of railways, and for removing obstructions on railways.

*21st Feb.* 1843. L. H. Potts. Improved method or methods of conveying goods, passengers, or intelligence.

*7th April*, 1843. R. and W. Hawthorne. Certain improvements in locomotive engines, part of which are applicable to other steam engines.

Improved apparatus, denominated "an auxiliary expansion slide frame," for working locomotive engines expansively

*20th April*, 1843. J. G. Bodmer. Certain improvements in locomotive engines and carriages, to be used upon railways, in marine engines and vessels, and in the apparatus for propelling the same, and also in stationary engines, and in apparatus connected therewith, for pumping water, raising bodies, and for blowing or exhausting air.

*22d June*, 1843. L. la Paige. Certain improved method or methods for preventing accidents on railways.

*22d June*, 1843. Samuel Ellis. Improvements in weighing machines, and in turn-tables to be used on, or in connexion with, railways, and in weighing machines, to be used in other situations.

*17th Aug.* 1843. F. Lipscombe. For an hydrostatic engine, parts whereof are applicable as improvements to other engines, and other purposes, and also improvements in railway carriages.—Described at page 472.

*8th Feb.* 1844. W. Newton. Improvements in propelling on railways.—Described at page 507

*24th Feb.* 1844. John Aitken. Improvements in atmospheric railways.

Producing a vacuum in the traction pipe, by filling it with water, and carrying off such water by eduction pipes descending about 35 feet below the traction pipes, with their ends immersed in water also; in rendering the longitudinal valve of the traction pipe air tight, by keeping it covered with water.

*6th March*, 1844. W. H. Barlow. Improvements in the construction of keys, wedges, and fastenings for engineering purposes.

The keys are of metal and are made hollow, as affording elasticity, lightness, and strength.

*19th March*, 1844. H. Inglis. Improvements upon locomotive steam engines, whereby a saving of fuel will be effected, which improvements are applicable to steam vessels, and other purposes, and to the increasing the adhesion of the wheels of railway engines, carriages, and tenders upon the lines of railways.

*30th April*, 1844. J. Samuda, and J. A. Samuda. Certain improvements in the manufacturing, and arrangement of parts and apparatus, for the construction and working of atmospheric railways.

*30th April*, 1844. John Melville. Improvements in the construction and modes of working railways.

*17th May*, 1844. J. Pilbrow. Certain improvements in the machinery for, or a new method of propelling carriages on railways and common roads, and vessels on rivers and canals.—Described at page 503.

*29th Aug.* 1844. W. Newton, Improvements in the means of preventing shocks, or accidents, on railways, or in lessening the dangerous effects arising therefrom.

*22d Oct.* 1844. J. Nasmyth and C. May. Improvements in working atmospheric railways, and in machinery for constructing the apparatus employed therein.

*9th Nov.* 1844. W. Prosser. Improvements in the construction of roads, and in carriages to run thereon.—Described at page 469.

The atmospheric main is connected with two cylindrical vessels, placed vertically, and which communicate alternately, with a steam boiler, and with a condenser, in which a jet of water is maintained; whereby a vacuum is produced in each cylinder in succession, (as in Savery's steam engine,) and the air rushing from the atmospheric main into the cylinders; becomes rarefied until the vacuum in the main is equal to that in the cylinders.

Another improvement consists in forcing down the brakes by pneumatic pressure.

14th Nov. 1844. J. Farrell. Certain improvements in machinery, whereby carriages may be impelled on railways, and tramways, by means of stationary engines or other power, including certain apparatus connected with the carriages to run on same.—Described at page 516.

18th Dec. 1844. W. Prosser. and J. Baptiste. Improvements in working atmospheric railways.

16th Jan. 1845. H. A. Dubern. Improvements in atmospheric railways.

16th Jan. 1845. H. Lacey and G. W. Buck. New method for manufacture of, and method for sustaining, the rails of railways.

Application of wrought iron to sustain the rails of railways, in lieu of the wooden sleepers, or of the stone blocks at present employed.

10th Feb. 1845. R. B. Longridge. Improved locomotive engine.

10th Feb. 1845. F. H. Maberly. Certain improvements in machinery, or the apparatus for stopping or retarding railway or other carriages, applicable also for these purposes in regard to other engines or wheels.

13th March, 1845. Thomas Dunn. Certain improvements in, or applicable to, turn-tables, to be used on or in connexion with railways.

7th April, 1845. E. Bury. Certain improvements in locomotive engines, carriages, or waggons running upon railways, or common roads, for the prevention of accidents.

10th April, 1845. E. Galloway. Improvements in propelling railway carriages.

Modification of Saxton's differential pullies, with a view to prevent the chafing of the rope—employment of wire rope, and an improved mode of attaching the drag carriage.

14th April, 1845 J. C. Hadden. Improvement in preparing sleepers, chairs, and spikes, and constructing wheels for railways.

10th May, 1845. W. Prosser and J. Brett. Improvements in railways, and in propelling railway carriages.

10th May, 1845. J. M. Chapman. Improvements in the manufacture of rails and other parts of railways.

17th May, 1845. A. Mac Dougall. Improvements in the method of working atmospheric railways.

5th June, 1845. Palmer. Improvements in working atmospheric railways, and in lubricating railway and other machinery.

23d June, 1845. Thomas Clarke, and John Varley. Improvement on the atmospheric system of propulsion, which is also applicable to other motive purposes.

23d June, 1845. R. Griffiths, H. G. Bovill, and G. Hennet. Improvements in the construction of parts of apparatus used for propelling carriages and vessels by the atmosphere; and improvements in propelling carriages and vessels by atmospheric pressure.

25th June, 1845. J Zambaux. improvements in atmospheric railways.

25th June, 1845. W. S. Ward. Improvements in exhausting air from tubes or vessels, for the purpose of working atmospheric railways.

3d July, 1845. John Hopkins. Certain improvements on rails, and trains for railroads, and tramways.

3d July, 1845. F. Walker and G. Mills. Certain improvements in springs and elastic power, as applicable to railway carriages and other vehicles, and to other articles and purposes in which springs, or elastic power, are now used.

Employment of air confined in bags to serve as springs to carriages, and employing ammoniacal gas as a motive power.

3d July, 1845. W. Newton. Certain improvements in railways, and in the means of propelling carriages.—Described at page 507.

8th July, 1845. Jacob Brett. Improvements in propelling carriages on railways and other roads and ways.

A hollow flat rail placed edgewise, extends the whole length of the line between the rails for the carriage wheels, and communicates by branch pipes at suitable distances with the pneumatic main, in which the air is highly compressed by means of air pumps, worked by stationary engines. The flat rail is

enveloped in an air-tight bag, and the compressed air in the rail distending the bag, causes it to press upon two rollers attached to the leading carriage, and thus impels the train.—See Keene and Nickel's invention, page 505.

A second improvement consists of a suspension railway worked by the same means.

*12th July, 1845.* J. S. Templeton. Impelling carriages on railways. A modification of one of Mr. Pinkus's plans, in which locomotive engines are worked by communication with a pneumatic main, in which the air is either rarefied or highly compressed by means of air pumps worked by stationary engines.

*12th July, 1845.* J. Malcomson. Improvements in apparatus used for propelling carriages on roads, and vessels on inland waters, when employing atmospheric pressure.

A close tube is laid along a line of railway, and a vacuum is maintained in it throughout its entire length, by the simultaneous action of all the stationary engines fixed along the line: the close tube communicates with the several sections of the valved atmospheric main, by means of branch pipes, furnished with valves, by opening which in succession a vacuum is created in advance of the piston, as it enters the different sections of the main.

*21st July, 1845.* J. Brett. Improvements in atmospheric propulsion, and in the manufacture of tubes for atmospheric railways and other purposes.

A series of hollow pistons, communicating with a pneumatic main, are placed midway between the rails at stated distances throughout the line, and attached to the train is a tube (named the locomotive tube), having on the under side a slit running the whole length of the tube, and at each end of the tube is a hinged valve. In the passage of the train, the tube receives within it the fixed pistons in succession, and the compressed air rushing through the pistons and impinging on the hanging valve at the end of the tube impels the train.

*29th July, 1845.* G. Beadon. Improvements in propelling vessels and land carriages in raising and drawing off water for driving machinery, which means of raising and drawing off water are applicable to other useful purposes.

Improvements in screw propellers, and applying a combination of oblique and direct propulsion to carriages, also a new pump and a mode of increasing the adhesion of bands to driving wheels.

*30th July, 1845.* E. Coleman. Improvements applicable to the moving of locomotive engines on inclined planes of railway.

Ascending inclines by means of an archimedean screw, attached to the locomotive, and working into a line of rollers, laid down midway between the rails. The screw is driven by bevelled gear, fixed on the shaft of the driving wheels, and on the axis of the screw.

*31st July, 1845.* J. Quick and H. Austin. Improvements in the construction and working of atmospheric railways.

1. Forming the tubes composing the atmospheric main of two or more longitudinal pieces, connected together by elastic joints, so as to allow the pipe to expand for the passage of the piston arm, and to close afterwards by the pressure of the atmosphere.

2. Working lines with numerous intermediate stations (as the Blackwall railway) by means of a close tube in which a vacuum is constantly maintained by the engines, and which communicates with the atmospheric mains by branch pipes fitted with valves.

3. An arrangement for making a smaller number of fixed engines suffice.

4. An expanding piston to suit enlargements of main, where greater power is required.

*7th Aug. 1845.* H. Smith. Improvements in the manufacture of wheels for railways, and in springs for railways and other carriages, and in axle-guards for railway carriages.

The principle of these improvements consists in a method of welding, forming, and fixing the tyres of wheels; and of making naves of wrought iron; of bending the plates of springs to the required shape, and in sawing the axle-guards out of plates of iron, brought to a red heat.

*7th Aug.* 1845. Emanuel Henry. Improvements in atmospheric railways.

The slit in the atmospheric tube is formed in the side of the tube, and the longitudinal valve is closed by the pressure of a long bag or hose, inflated with air and protected by a shield of wrought iron bolted to the tube.

The vacuum in the tube is produced by first filling with water large close reservoirs, connected with the tube by pipes and valves, and the opening the communication between the two, and allowing the water to run off.

*2d Oct.* 1845. J. R. Hill. Certain improvements in atmospheric propulsion applicable to water as well as land carriages.

*6th Oct.* 1845. M. Poole. Improvements in rails for railways.

*6th Oct.* 1845. T. R. Crampton. Improvements in locomotive engines and railways.

*10th Oct.* 1845. F. Harlow. Improvements in atmospheric railways.

*16th Oct.* 1845. S. Reed. Certain improvements in railway rails and chairs.

*23d Oct.* 1845. T. Worsdell. Certain improvements in apparatus to be attached to, and employed in connexion with, railway carriages.

*23d Oct.* 1845. J. Orsi. Improvements in sleepers or blocks for supporting railways.—Described at page 425.

*23d Oct.* 1845. Fuller. Improvements in the construction of railway carriages.

*31st Oct.* 1845. R. W. Brandling. Improvements in railways and railway carriages, for the security and convenience of the public.

*31st Oct.* 1845. C. H. Collins. Improvements in atmospheric railways.

*31st Oct.* 1845. D. Crawford. Improved means of, or machinery for, arresting the progress of railway carriages and trains.

*31st Oct.* 1845. J. Forsyth. Certain improvements in signals, or in the method of giving signals, which are applicable to the working of railways, and which are also applicable to maritime purposes, and for certain improvements in working of railways.

*11th Nov.* 1845. B. Donkin. Improvements on wheels, as applicable to railway carriages, and on the mechanical contrivances by which railway carriages are made to cross from one line to another line, or on to what are generally called "sidings."

*11th Nov.* 1845. G. H. Dutton. Certain improvements in conveying intelligence from one part of a railway train to another.

*18th Nov.* 1845. J. O. Ward and W. Hillis. Improvements in the construction of railway, and in machinery and apparatus for working carriages.

*18th Nov.* 1845. C. Vaux. Improvements in apparatus or machinery for preventing accidents to carriages and passengers on railways, part of which improvements are applicable to save lives and property in other places.

*18th Nov.* 1845. E. B. Wilson. Improved apparatus applicable to swivel bridges and turn-tables.

*18th Nov.* 1845. H. B. Powell. For certain improvements in carriages to be used on rail and other roads.

*20th Nov.* 1845. Ernest Edge. For certain improvements applicable to the wheels and axles of engines, tenders, carriages, and waggons, to be used upon railways.

*4th Dec.* 1845. Robert Rettie. For an improved method of signaling or telegraphing on sea or land, preventing collision at sea, and giving signals of distress, by improved burners with glasses coloured and signal cards, applicable to railways in all the various departments, as well as preventing of accidents, when the train is at full speed; also the diurnal for railways, towns, villages, &c.

*6th Dec.* 1845. J. R. Johnson. For improvements in the materials employed in constructing and working atmospheric railways.

*20th Dec.* 1845. Taylor and Conder. Improvements in propelling on railways—Described at page 509.

*30th Dec.* 1845. T. Swinburne. For improvements in railways, and in the means of propelling and carrying thereon.

*6th Jan.* 1846. C. H. Greenhow. For improvement in the construction of railways and railway carriages.

- 6th Jan. 1846. J. R. Bozek. For improvements in the construction and application of railroad carriage wheels.
- 13th Jan. 1846. R. B. Longridge. For an improved locomotive engine.
- 20th Jan. 1846. R. A. Brooman. For certain improvements in railway and common road carriages.
- 22d Jan. 1846. C. Wheeler. Certain improvements in the construction and working of railways.
- 22d Jan. 1846. F. W. Campin. Certain improvements in obtaining and applying motive power.
- 31st Jan. 1846. M. Rimington. Certain improvements in obtaining and applying motive power.
- 31st Jan. 1846. A. Etienne. Improvements in the construction of railways, railway carriages, and in the means of preventing accidents on railways.
- 3d Feb. 1846. E. Chesshire. Improvements in apparatus to be applied to railway carriages, to reduce the prejudicial effects of collisions to passengers in railway carriages.
- 3d Feb. 1846. S. Brown. Improvements in gas engines, and propelling carriages.
- 11th Feb. 1846. Clark, Freeman, and another. Improvements in obtaining and applying motive power.
- 11th Feb. 1846. G. Stephenson. An improvement in locomotive steam engines.
- 16th Feb. 1846. Nasmyth. Improvements in engines, or machines for obtaining and applying motive power.
- 19th Feb. 1846. R. Nisbet. Improvements in locomotive engines.
- 27th Feb. 1846. J. S. Templeton. Improvements in propelling carriages on railways, and improvements in propelling vessels.
- 11th March, 1846. W. Nairne. For a new mode or new modes of propelling carriages along railways.
- 11th March, 1846. H. Austin. Improvements in the construction of railways and railway carriages.
- 11th March, 1846. H. Bovill and another. Improvements in apparatus applicable to the working of atmospheric and other railways, canals and mines, and improvements in transmitting gas for the purpose of lighting railways.
- 11th March, 1846. J. Banfield. Improvements in making signals and communications on railways and between railways, engines, carriages, and trains, which are also applicable to other localities.
- 23d March, 1846. J. H. Gandell and another. Improvements in the construction of, and in the mode of opening and closing of, moveable bridges or arches, for the purpose of carrying railways, tramways, or other roads, across canals, locks, docks or other open cuttings.
- 25th March, 1846. T. Pope. Improvements in apparatus for moving railway carriages on to railways, and in machinery for lifting or moving heavy bodies.
- 18th April, 1846. E. Galloway. Improvements in locomotive engines.
- 7th April, 1846. T. Melling. Improvements in marine stationary and locomotive engines.
- 28th April, 1846. C. de Bergue. Improvements in atmospheric railways.
- 22d May, 1846. H. G. Hulme. Improvements in the construction of railways, and in the carriages to be used thereon.
- 26th May, 1846. J. Montgomery. Improvements in the construction of steam boilers and steam engines, and in steam vessels, and in the machinery for propelling the same.
- 26th May, 1846. F. A. Cowper. Improvements in the manufacture of railway chairs.
- 4th June, 1846. J. C. Robertson. Improvements in railways and railway carriages.
- 17th June, 1846. W. Cormack. Improvements in obtaining motive power.
- 10th Dec. 1846. T. V. Allier. For improvements in brakes or machinery for stopping or retarding carriages.

**RAISINS.** Grapes, prepared by suffering them to remain on the vine till they are perfectly ripe, and then drying them in the sun, or by the heat of an oven. The former are esteemed as much the best.

**RANCIDITY.** That sensible change which first takes place in oils, when exposed for some time to the air; supposed by chemists to be analogous to the oxidation of metals. For it appears that the processes employed to counteract rancidity, depend upon the combination of oxygen with the extractive principle, with which the oily principle is naturally combined.

**RAREFACTION.** The act whereby a body is brought to occupy more space, or expand into a larger bulk, without the apparent accession of any new matter. This is commonly regarded as the effect of heat, or the matter of caloric, repelling the particles of the body rarefied farther from the centre of aggregation.

**RASP.** A species of file, on which the cutting prominences are distinct, being raised by punching with a point, instead of cutting with a chisel.

**RATAFIA.** An alcoholic liquor prepared from the kernels of various kinds of fruits, particularly those of cherries and apricots.

**RATAN.** A kind of cane much employed in the useful arts. They grow in profusion along the banks of rivers in parts of Asia and the neighbouring islands. Certain species furnish cables, cords, and withes, of exceeding strength; others are split into strips for making the seats and backs of chairs, baskets, and other light and elegant articles of furniture; those which are larger and firmer, and whose joints are more distant, afford elegant walking-sticks.

**RATCH.** A bar containing angular teeth, into which a pall drops, to prevent machines from running back. A circular ratch is called a ratchet wheel.

**RECTIFICATION.** A careful repetition of distillation, by which the results are purified. See **ALCOHOL**.

**REED.** That part of a loom resembling the teeth of a comb, between which the threads of the warp are separated.

**REELS.** Rotatory cylinders, or frames, on which lines, threads, &c. are wound.

**REEMING.** The opening of the seams between the planks of vessels, by caulking irons, for the purpose of caulking or re-caulking them with oakum.

**REFINING, in general,** is the art of purifying any thing; but the term is commonly understood to apply to the purification of metals, particularly gold and silver, from the alloys with which they may be mixed. As gold and silver alone can resist the combined action of air and fire, there is a possibility of purifying gold and silver from all alloy of the other metals merely by the action of fire and air, only keeping them fused till all the alloy be destroyed; but this purification would be very tedious and expensive, from the great consumption of fuel. Silver alloyed with copper has been exposed above sixty hours to a glass-house fire, without being perfectly refined: the reason is, that when a small quantity only of other metals remains united with gold and silver, it is protected from the action of the air, which is necessary for combustion. This refining of gold and silver merely by the action of fire, which was the only method anciently known, was very tedious, difficult, imperfect, and expensive; but a much shorter and more advantageous method has been long practised. This consists in adding to the alloyed gold and silver a certain quantity of lead, and in exposing this mixture to the action of fire. The vessel in which the refining is performed, is hollow, but shallow, that the matter which it contains may present to the air the greatest surface possible. This form resembles a cup, and hence it is called a cupel. The furnace ought to be vaulted, that the heat may be applied to the surface of the metal during the whole time of the operation. Upon this surface a dark-coloured crust or pellicle is always forming; but when all the other metals are dissipated, the surface of the gold and silver is seen clear and brilliant; which indicates that the metal is free from alloy.

**REFLECTION, in Mechanics,** is the return or regressive motion of a moveable body, arising from the reaction of another body on which it impinges. The reflection of bodies after impact, is attributable to their elasticity; and the more perfectly they possess this property, the greater will be their reflection, all other circumstances being the same.

**REFRACTION**, in *Mechanics*, is the deviation of a body in motion from its original course, arising from the different densities of the several parts of the medium through which it passes.

**REFRIGERATORY**, in *Chemistry and Distillation*, is a vessel for cooling liquids, or condensing vapour into liquids, by the application of cold water. The common worm-tub is a specimen; but refrigeratories are of numerous forms. See **ALCOHOL**, **CONDENSER**, &c.

**REGISTER**. An aperture or valve placed in a chimney, stove, or furnace, for regulating the quantity of air to be admitted.

**REGULUS**. A term that was given to metallic matters when separated from their ores by fusion.

**RELIEVO**, or **RELIEF**, are terms applied to that mode of working in sculpture by which figures are made to project from the ground or body on which they are formed, and to which they remain attached. The same term is used, whether the figure is cut with the chisel, modelled in clay, or cut in metal or other substance. There are three kinds of relieve:—First, *alto-relievo*, (or high relief,) when the figures are so prominent from the ground, that merely a small part of them remains attached to it. *Mezzo-relievo*, (or half relief,) when one half of the figure rises from the ground, in such manner that the figure seems divided by it. *Basso-relievo*, (or low relief,) when the work is raised but little from the ground, as in medals, and generally in friezes, and other ornamented parts of buildings. *Low-relief*, or *bas-relief*, is the comprehensive term by which all works in relieve are usually indiscriminately denominated.

**RENNET**. The coagulum prepared from the stomach of a calf, employed in making cheese.

**REPULSION**, in *Physics*, that property in bodies, whereby if they are placed just beyond the sphere of each other's attraction of cohesion, they materially recede and fly off.

**RESIN**. A solid inflammable substance of a vegetable origin, and soluble in alcohol; it resembles gum in appearance, but differs from it chiefly in its insolubility in water; in which gum is soluble, and not in alcohol. Resins appear to have been volatile oils rendered concrete by the absorption of oxygen. The exposure of these to the open air, and the decomposition of acids applied to them, evidently prove this conclusion. What is most generally known by the name of resin, or *rosin*, is the residuum left after distilling the essential oil from turpentine, and which is run or ladled out of the still into casks cut in half, for sale. In commerce, this product is called *brown rosin*. The *yellow rosin* is made by ladling out the brown rosin from the still into a vessel of hot water; a violent effervescence ensues, and the rosin absorbs one-eighth of its weight in water. It is more friable than the brown rosin, but the lighter colour of the yellow adapts it better to some purposes.

**RESISTANCE**, in *Fluids*, is that opposition to the motion of a body which arises from the inertia, tenacity, and friction of the parts of the fluid in which it moves. If any body move through a fluid with a given velocity, it will evidently displace a certain number of particles with a given velocity; but in thus giving motion to the particles of fluid, it must lose a part of its own, which loss of motion is the effect of resistance. When a body changes its velocity, the resistance is not changed in the same proportion; for if a body move with double its former speed, it will manifestly set in motion twice as many particles, and each of these particles will be moved with double its former velocity. In the same way, if the velocity be tripled, three times the number of particles must be put into motion with a triple velocity. Thus it appears that a double velocity produces a fourfold resistance, a triple velocity a ninefold resistance; that is, the resistance increases proportionally to the square of the velocity. The resistance is also increased in the same proportion as the area of the plane immersed; it is also increased as the density of the fluid medium. If the plane does not move with its face perpendicular to the direction of its motion, the resistance will be diminished, both on account of a less surface being exposed, and the oblique action of the particles on the plane. From these two causes the resistance will be diminished as the cube of the sine of the angle that the

plane makes with the direction of its motion. The resistance is the same, whether the body move in the fluid, or the fluid move against the body. The absolute resistance to a given plane, by a fluid acting with a certain velocity perpendicularly to its face, is equal to the weight of a column of fluid, whose base is the plane and height equal to that through which a heavy body must fall to acquire the given velocity: a consideration of the law of resistance, a limit to our speed in navigation, which soon becomes insuperable.

**RESOLUTION OF FORCES**, or *resolution of motion*, is the act of dividing any single force or motion into two or more others, in different directions; or of finding the quantities of two or more forces or motions, which, taken together, shall produce the same quantity of force or motion with the given one, and in the same direction. This is the reverse of **COMPOSITION OF FORCES OR MOTION**; which see.

**RETARDATION**. The act of checking or diminishing the velocity of a body in motion. The two grand causes of the retardation of moving bodies are, the resistance of the medium through which the body moves, and the action of gravity.

**RETORT**. A vessel used in distillatory processes, usually of a pear shape, with a long beak; but they are modified in a great variety of ways. See **GAS**.

**REVERBERATORY**. A furnace or oven, wherein the flame, or current of heated gases from the fuel, is caused to reverberate, or be reflected down upon the substance under operation, before passing into the chimney: such reverberatories are therefore usually made with dome tops, against which the flames &c. first impinge, and then curve downwards upon the bed of the furnace.

**RHODIUM**. A new metal, discovered by Sir H. Davy amongst crude platina; specific gravity, 11. It unites easily with every metal with which it has been tried, except mercury: with gold or silver it forms a very malleable alloy, not oxidated by a high degree of heat, but becomes encrusted with a black oxide when slowly cooled; one-sixth of it does not perceptibly alter the colour of gold, but renders it much less fusible.

**RICE**. A hard, white, farinaceous, and very nutritive grain, which grows in the East and West Indies, and other warm climates; it grows to the height of about  $2\frac{1}{2}$  feet, with a stalk not unlike that of wheat, but fuller of joints, and with leaves resembling those of the leek. It branches out into several stems, at the top of which the grain grows in clusters, and each of them is terminated with an ear or beard, enclosed in a yellow rough husk. When stripped of this rough coat and a thin under-skin, the grain is shown to be of an oval form, and of a beautiful white colour. The native mode of shelling rice (or paddy, as it is called in the rough state) in India, is by placing it in a large hollow stone or mortar, and striking the loose grain with a conical stone or pestle, by which it is constantly forcibly pressed and disturbed; and thus, by persevering efforts, the husks are rubbed off. This process is, however, a very tedious and laborious one, and to remedy it, a variety of inventions have been successively introduced and improved upon. The general practice, of late years, has been to employ millstones for depriving the paddy of the outer shell, the stones being set at such a distance apart as will detach the shell, without crushing the interior grain. The stones are covered by a hoop or case, which entirely encloses them, leaving a space all round between the stone and the hoop of about two inches. In one side of this hoop is a hole, through which the husked rice runs out upon a fine sieve, kept agitated by the mills; in passing over this, the dust and sand are separated; it then falls into the winnowing machine, which separates the husk from the rice. There is one of these machines to each pair of stones, to separate the rice from the husk, in its passage from the stones to the bin.

The rice in this stage of the operation is more or less red, nothing more being done than the separation of the husk; after this, it is taken to the whitening machine, where the inside cuticle, or red skin, is detached. This machine consists of a stone of coarse grit, fixed on a spindle like a grinding-stone; the stone is enclosed in a case made nearly to fit, leaving a space all round of about an inch between the stone and the inside of the case: this case is made of plate iron, and punched full of small holes, like a grater, with the



rough side inwards; it is so contrived, that the case may go round with the stone, or it may remain still while the stone is turning. The rice is put in between the case and the stone at a sliding door, or opening in the rim; the space is about two thirds filled; the stone is then put in very rapid motion, making at least 250 revolutions a minute, by a strap. The case is allowed to turn very slowly; this changes the position of the rice, and every grain in succession comes into contact with the stone, and, rubbing hard against each other, an accumulation of heat (which produces an enlargement of the grain, and consequently splits the red skin) is produced, which serves to loosen the skin; and this, forming a red dust, finds its way out of the holes in the case, and leaves the rice perfectly white.

The cleansing of rice in this country is of modern introduction, and, from its apparently growing importance, we shall add some account of the processes recently patented for that purpose.

Mr. Ewbank's patent of 1819 informs us that the paddy is first cleansed from foreign matter by passing it over a screen, which, detaining the rice, allow the impurities to pass through. The paddy in this state is taken to millstones, set at a proper distance apart to rub off the external shells or husks; the husks are next blown away by a fanning machine; the rice, thus partially cleaned, is then deposited in mortars, where it is beaten and tritulated for depriving it of the thin red skin; and when the trituration has been carried far enough, the contents of the mortars are sifted upon a "sloping and revolving screen," which is composed of three distinct wire-cloths, of different degrees of fineness. The finest under cloth allows the dust or flour to pass through, but detains the broken rice; the second or middle cloth separates the broken, and detains the whole rice, while the coarsest upper cloth allows only the whole rice, or husked grains to pass through, and detains the unhusked, which is taken back to the millstones to be operated upon again. The rice, still but imperfectly clean, is afterwards taken to the polishing and whitening machine, which consists of two cylinders placed concentrically; the exterior cylinder is fixed or stationary, and the interior one, which is made to revolve, is covered with sheep-skins with the wool on the outside. Between these two cylinders the rice is put, and the inner cylinder being made to revolve, the rice is brushed by the constant friction of the wool, and thereby polished and whitened.

A second patent granted in May, 1827, to Messrs. Lucas and Ewbank, relates to an improved method of treating the rice, that is, after it has been husked. For the purpose of depriving or getting rid of the red pellicle, which is united to the rice by a gummy substance, they employed in succession two or more sets of mortars. When, by the trituration of the pestles, the gummy or glutinous matter begins to disengage itself (which is immediately manifested by the rice moving sluggishly under the pestles), it is to be taken out of the first set of mortars, and carried to a second set, wherein it is to be mixed with the rice a quantity of the external husks well dried, in the proportion of one fourth or two-fifths in bulk to that of the rice. The trituration and beating process is then renewed upon this mixture, the dry husks greatly assisting in cleaning and whitening the grain. After this the mass is to be fanned and screened, to separate the refuse; when the rice is taken to the polishing machine, as before described, which terminates the process.

In the month following the date last mentioned, Mr. Melvil Wilson, a merchant of London, took out a patent for an improvement in husking rice, in which the operation was conducted simply by the collision of the grains of paddy against each other.

The apparatus consists of a long hollow cylinder, around the interior surface of which are fixed a series of angular bars, projecting towards the axis of the cylinder; this cylinder revolves loosely on a central shaft, which passes through it, and is provided with a similar number of bars, pointing radially from the centre to the circumference, and passing alternately between the bars in the cylinder, so as to leave an inch free space between them. Thus disposed the cylinder is placed in an inclined position; the rice is allowed to enter it at the top, while the cylinder is made to revolve with a "slow motion" in one

direction, the axis moving at the same time at "a high speed," and in a contrary direction; consequently, as the rice passes through the cylinder, it will be considerably agitated and turned about; and the husk will, it is said, be rubbed off before passing at the lower end of the cylinder.

To render the construction of the interior of the cylinder perfectly understood, the annexed diagrams will be sufficient.

Fig. 1 represents a plan of the cap of the cylinder, not fixed thereto, nor to the axis, which passes through it, but to the framing which supports the hopper; it serves to guide the grain into the cylinder, and to keep out adventitious substances.

Fig. 2 is called, in the specification, "a socket wheel;" it is fixed directly under the cap to the cylinder, and the axis passes through the socket, which serves, therefore, as a bearing for both the axis and the cylinder, permitting them to revolve freely in contrary directions. For the convenience of removal, this wheel is made to divide into two parts, which are bolted together when in use.

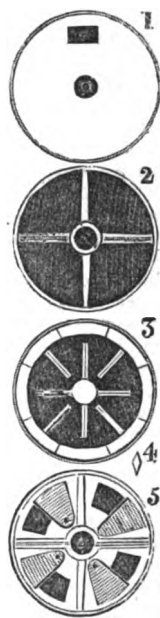
Fig. 3 gives a transverse section of the cylinder and axis, each of which being shown as provided with four bars, that number being fixed in each parallel circle, and alternately as respects those on the cylinder, and those on the axis. This section likewise shows the cylinder to be composed of eight distinct pieces or segments; on each of the eight segments is fixed a longitudinal row of similar bars, though only four (the number in one circle) are brought into view, to prevent confusion.

Fig. 4 is a transverse section of one of the before-mentioned bars, showing that they are of the figure of a quadrangular prism, that shape being preferred by the patentee for the purpose in question.

Fig. 5 is a plan of the bottom of the cylinder; it is formed in part like the socket wheel, described in Fig. 2, but the spaces between the spokes are closed; in each of these compartments a large aperture is made for the egression of the grain, which is regulated at pleasure, by sliding doors to each, as represented.

Mr. Wilson took out a second patent in 1830 for "an improved method of preparing and cleansing paddy or rough rice," which may be briefly described as consisting of a series of mortars with solid bottom and *sieve sides*; the latter being made of wire gauze, or perforated metal plates, strengthened by ribs of strong wire. These mortars are placed in a row, and their contents operated upon by a series of pestles suspended to a revolving crank shaft above, the pestle rods being guided in their action by a suitable frame underneath, sliding between upright standards which support the crank shaft. The intention of the "sieve sides" to the mortars is, that the rice may pass through as soon as it is cleaned, so as not to be heated by the subsequent operation of the pestles.

We shall mention one more patent, which was recently granted to Mr. Shiel, of Liverpool, for the same object. Instead of a pair of millstones for the first operation of shelling, the specification of this patentee directs the employment of *one mill-stone*, and what we will take leave to call *one mill-wood* (of precisely similar figure to the stone), and between these two substances the paddy is to be milled in the same manner as between two stones. The second operation of taking off the thin pellicle is to be performed by rubbing the grain between the flat surfaces of two wooden runners, which are covered with sheep-skin with the wool on. But Mr. Shiel's mode of applying the sheepskin is different to Mr. Ewbank's before described; the wool being placed by Mr. Shiel next to the surface of the runners, so that the rice is operated upon by the flesh sides of the skins, and owing to the springiness of the wool underneath, the grain receives an elastic pressure.



**RIFLE.** The name given to a fire-arm from the peculiar construction of its barrel, which is cut internally into long spiral grooves, that usually make but one revolution through its length.

**RIGGER.** A cylindrical pulley; known also by the term drum, in machinery.

**RIGGING.** A general name given to all the ropes employed to support the masts, and to extend or reduce the sails, or arrange them to the disposition of the wind.

**ROADS.** The subject of this article opens to us so vast a field of inquiry, that it is impossible to do justice to its importance within the limits prescribed to us. To the curious explorer of ancient records, a search into the history of roads, from the earliest ages of antiquity, would repay his utmost labour. While to the philosopher it offers ample scope for meditation and reflection; the theorist may speculate on the influence, moral and political, exercised by facility of communication between distant members of the same body politic; and the sound reasoner find, in the opening of good roads alone, data on which to base a true estimate of the progress of society.

Roads may be described as both the cause and effect of civilization; the formation of roads invariably tending to improve the most barbarous district, to evolve its resources, and civilize its people; while, on the other hand, the internal communications of a country afford the surest proof of her prosperity; and her roads, the infallible signs, because the certain consequences, of her civilization. "Let us travel," says the Abbé Raynal, "over all the countries of the earth, and wherever we find no facility of travelling from a city to a town, or from a village to a hamlet, we may pronounce the people to be barbarians." "The making of roads," observes Sir Henry Parnell, in his admirable *Treatise*, "in point of fact, is fundamentally essential to bring about the first change that every rude country must undergo, in emerging from a condition of poverty and barbarism."

The wise policy of the Romans taught them to lay open the countries they subdued, which might afford an easy transport of their ammunition and supplies. In Britain, some remains of the Roman roads are yet visible. At Chester, remnants of the old Roman pavement, called the *Castrum*, are frequently discovered on removing the superincumbent soil; in Scotland, a portion of Roman causeway, leading from Musselburgh Bay to Abercorn; in the neighbourhood of St. Albans on the road to London—and in many other places. All the roads discovered ran nearly in direct lines. Natural obstructions were removed or overcome by the efforts of labour and art, whether they consisted of marshes, lakes, rivers or mountains. In flat districts the middle part of the road was raised into a terrace. In mountainous districts the roads were alternately cut through mountains and raised above the valleys, so as to preserve either a level line, or a uniform inclination. They founded the road on piles where the ground was not solid, and raised it by strong side walls, or by arches and piers, where it was necessary to gain elevation. The paved part of the great military roads was 16 Roman feet wide, with two side ways, each 8 feet wide, separated from the middle way by two raised paths, 2 feet each. At every mile columns were erected, to mark the distance from place to place; blocks of stone for foot travellers to rest upon, or for horsemen to mount their steeds with; temples, triumphal arches, and mausoleums adorned them, and military stations defended and commanded. By the formation of these great highways, an impulse was given in Britain to the national industry. The genius of the British people, essentially commercial, hastened to avail itself of the facilities (limited as they were) for intercourse and traffic; and we may fairly attribute to the conquest of Britain by the Romans her present commercial superiority.

A road should combine the qualities of hardness, smoothness, and strength or solidity. To obtain these requisites, it appears to us indispensable that great care should be taken to prepare the foundation for the materials; but on this point much diversity of opinion exists; Mr. M'Adam maintaining that the elasticity of the subsoil is rather a benefit than an injury, in contradiction to

the opinion of Mr. Tredgold, and other eminent engineers, that on a substratum of a spongy nature, as bog-land, or morasses, it is imperative to render the foundation firm.

**Drainage.**—In properly conducting this part of the business of road-making, great care is necessary. The utmost judgment of the skilful surveyor will be called into action to enable him to make the best use of the natural facilities of the country, and to overcome the obstructions that he will sometimes meet with. In passing over flat land, open main drains, cut on the field side of the fences, must communicate with the natural watercourses of the country; they should be three feet deep below the level of the bed of the road, one foot wide at bottom, and five feet wide at top. If springs rise in the site of the road, or in the slopes of deep cuttings, stone or tile drains should be made into them. In cutting, small drains, technically called mitre drains, should be formed; the angle, depending on the inclination of the road, should not exceed 1 inch in 100. They should be 9 inches wide at bottom, 12 inches at top, and 10 inches deep. According to the inclinations of a road, and the form and wetness of the country, cross-drains of good masonry should be built under the road, having their extremities carried under the road fences. One of these should be built wherever water would lie; and when the road passes along the slope of a hill, great numbers are necessary to carry off the water that collects in the channel of the road on the side next the high ground. Various descriptions of drains are made in every situation where necessary, and the preservation of the surface of the road secured by giving it a proper convexity in its cross section, as shown in the annexed section, designed for the regulation of the surfaces and wastes between the fences of the Holyhead road.



The proper convex form is particularly essential on hills, in order that the water may have a tendency to fall from the centre to the sides. The side channels, and all the road drains, should be repaired at the approach and at the end of the winter, and daily attention given to their being free from obstruction. If roads, by a proper system of drainage, be kept dry, they will be maintained in a good state, and at proportionally less expense.

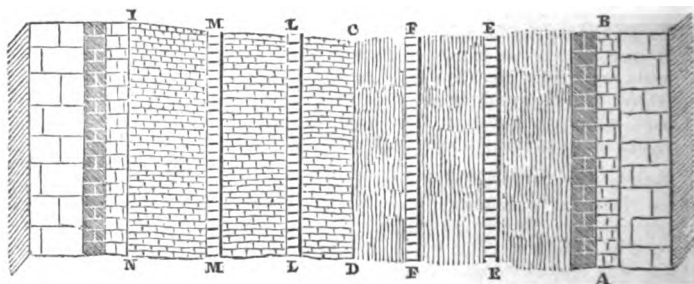
**Materials, &c.**—The breadth of roads should vary according to circumstances. In the vicinity of large towns, where the traffic is considerable, the road should be not less than 60 feet between the fences. Where there is less traffic, fifty feet will be sufficient. The whole breadth should, in these cases, be *metalled*, or laid with broken stones. Near London, and the capitals of Edinburgh and Dublin, perhaps 70 feet is not too great a width, and a footpath should be provided on each side. "The road," says Mr. Telford, in a specification for the Holyhead road, "is to be 30 feet wide, exclusive of footpaths, with a fall of 6 inches from the centre to the side channels." The bed of the new road being prepared for the reception of the materials, should, if of a wet or spongy nature, be well 'rammed' with chips of stone; in some situations it is advisable to lay a stratum of *hand-laid* stones, of from 5 to 7 inches in depth, with their broadest ends placed downwards, and the whole built compactly together. On this is to be laid the 'metal,' or broken stones, to the depth of at least 8 inches, broken of a uniform size, so as to form a solid and compact body. To insure uniformity in the size of the broken stones, various tests have been suggested; perhaps the most simple is, that every piece shall pass through a ring of 2½ inches diameter. On this body of metal, no binding or gravel should be used;

the angular sides of the metal soon lock into each other, and form a smooth surface. In the selection of road-metal, we prefer the several varieties of greenstone. The best kinds of these are less friable than granite, when broken into small pieces. It is, however, often necessary, for want of better materials, to use sandstone, common limestone, and chalk, even in districts where there is a great deal of traffic; in some instances, where coal is abundant, sandstone is reduced to a vitreous mass in kilns erected by the road side.

"Well-made roads, formed of clean, hard, broken stone," observes Mr. Macneill, "placed on a solid foundation, are very little affected by changes of atmosphere; weak roads, or those that are imperfectly formed with gravel, flint, or round pebbles, without a bottoming, or foundation of stone pavement or concrete, are, on the contrary, much affected by changes of the weather. In the formation of such roads, and before they become bound or firm, a considerable portion of the sub-soil mixes with the stone or gravel, in consequence of the necessity of putting the gravel on in thin layers: this mixture of earth or clay, in dry, warm seasons, expands by the heat, and makes the road loose and open; the consequence is, that the stones are thrown out, and many of them are crushed and ground into dust, producing considerable wear and diminution of the materials. In wet weather, also, the clay or earth mixed with the stones absorbs moisture, becomes soft, and allows the stones to move and rub against each other, when acted upon by the feet of horses or wheels of carriages. This attrition of the stones against each other wears them out surprisingly fast, and produces large quantities of mud, which tend to keep the road damp, and by that means increases the injury."

The immense traffic in the streets of London, and other large cities, and the inconveniences resulting from a frequent derangement of the pavement, have long rendered the establishment of a firm, durable, and smooth city road, a great desideratum. The alternate dust and mud on broken stone roads have proved them unfit for crowded thoroughfares. They have been tried, but failed. Stone paving of various kinds, and even cast-iron plates, in the form of

Fig. 1. (Plan.)



a causeway, have been suggested. Of the two kinds of stone pavement with which London, Dublin, and Edinburgh, are paved, the one is termed rubble causeway, the other aisler causeway. In the former the stones are very slightly hammer-dressed; in the latter they vary from 5 to 7 inches in thickness, from 8 to 12 in length, and about a foot in depth. The Commercial Road of London is a fine specimen of the aisler causeway. It leads from Whitechapel to the extensive establishments of the East and West India Docks, at Blackwall and Poplar. It is 2 miles long, and 70 feet wide. The footpaths are laid with Yorkshire flags, and the stoneway of granite. The tramway is composed of large stone blocks, 18 inches wide by 12 inches deep, and from 2½ to 10 feet long. They are laid in rows four feet apart, on a hard gravel bottom, or a concrete foundation, and have their ends closely and firmly jointed to each

other, so as to prevent movement, either lateral or longitudinal. On this tramway a waggon weighing, with its load, 10 tons, was drawn by one horse from the West India Docks, a distance of 2 miles, rising 1 in 274, at the rate of nearly 4 miles per hour. The works were executed under the direction of Mr. James Walker, the engineer, by whom the plans were furnished, and whose report to the trustees of the road contains much useful information.

Mr. Stephenson, the engineer, describes in the *Edinburgh Encyclopædia* a mode of constructing a smooth and durable city road, which is both economical and ingenious.—“A street or highway, supposed to measure about thirty feet in

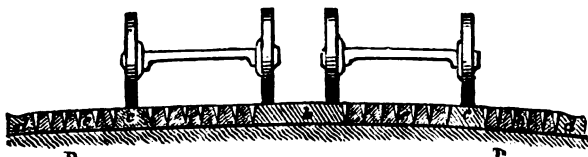


Fig. 2. (Section.)

breadth, is laid out in five compartments, independently of foot-paths. Two of these are laid with the aisler causeway tracks, five feet apart, the horse-paths of rubble causeway, or broken stones, in the usual way. A B C D (*Fig. 1*) point out a compartment of the road, laid partly with broken stones, in which E E and F F are the aisler causeway tracks, A B being a paved open drain, on the side of the road. I N shows the limits of a road, also laid with tracks of aisler causeway, as marked at L L and M M; but here the compartments between and on each side are paved with rubble, or inferior causeway stones. *Fig. 2* is a section of the plan described under *Fig. 1*, and shows the particular form of the aisler causeway tracks; *a* is a paved drain, *b* one of the sides, made with broken stones, *c c* two of the aisler causeway tracks, and *d* the horse-path between them.

In the year 1825, Mr. Thomas Parkins obtained a patent for an improved mode of paving. The patentee proposed to lay on common roads continuous lines of granite blocks, on which the wheels of carriages are to run; the upper surfaces are to be level with the road, the under surface flat, and the stones are fitted together by “bird’s-mouth joints.” Each stone is thus supported by the stones on each side of it, and prevented from partial depression. Whatever

Fig. 3.



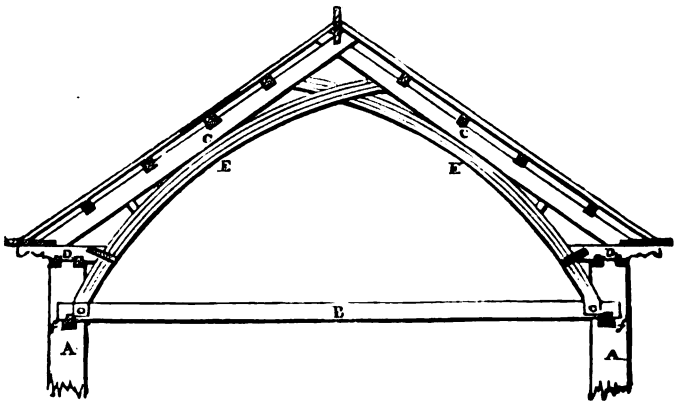
merit may be due to Mr. Parkins for the methods he has suggested, so many and so various are the improvements in pavements since the date of his patent, that it is unnecessary to describe more minutely the several modes by which he proposes to connect the blocks of stone together.

In the same year, a patent was granted to Mr. John Lindsay, of the Island of Herm, near Guernsey, for certain improvements in paving; it is described in Vol. XI. No. 64, of the *London Journal*. *Fig. 3* is a cross section of the street; D D is a properly-prepared foundation; *b* and *c c* are blocks of smooth granite, placed longitudinally, and parallel to each other, for the carriage

wheels; *dd* are also stone blocks, with trenches in their upper surfaces, to serve as drains for surface moisture or rain. The intermediate spaces *eee* are filled up by common paving stones, with their broadest surfaces downwards, the interstices to be filled with granite chips or cement. The central line of granite blocks *b* is to be sufficiently broad to allow two carriages to pass; and the side blocks *c c* are only required to be wide enough for one wheel to run on. Upon the kerbs, carriages with heavy loads will pass with ease, and comparatively little labour to the horses. Mr. Lindsay's plan of preparing the foundation for the reception of the blocks, it is unnecessary to detail; and we believe the method of fastening the blocks by cramps or bars of iron, has been long known, and, in many cases, acted upon. Though we conceive his invention to possess but little novelty, the patentee deserves credit for *attempting* to improve our street pavement; so valuable, as we have before observed, in a smooth and solid roadway, that every suggestion for its attainment is entitled to respect.

Mr. H. T. Cassell of Mill Wall, Poplar, has obtained a patent for a bituminous composition, called by him "lava stone." The patentee describes the merits of the invention to consist in the discovery of a mode of combining certain materials to form a species of stone uniting the advantages of metal with those of stone. The properties of this stone are durability and toughness. It does not absorb water, and is a non-conductor of heat. Each of these properties can, in the process of combination, be increased or diminished, to suit the purposes for which the stone is intended. In paving a street, the following method is pursued:—Instead of disturbing the bottom, it is to be consolidated by picking, raking, and rolling. A coating of bituminous lava is then run over, and the whole rendered impervious to water. This coating is then to be paved over with granite stones of the usual description, and the interstices are to be filled in with hot bituminous lava.

ROOF. The top covering to a house or other building; in which sense it comprises the timber work, slate, tile, lead, with whatever else is necessary to form and complete the whole. Roofs are of various forms. First, the *pointed roof*, in which the ridge, or the angle formed by two rafters at the point at top where they meet, is an acute angle. Secondly, the *square roof*, in which the angle at the ridge, formed as above, is a right angle. Thirdly, the flat roof, or rather



*pediment roof*, which has the angle at the ridge more or less obtuse. There are various other forms, as the *hip-roof*, the *valley-roof*, the *hopper-roof*, the *salt-box roof*, the *round roof*; and when the covering of a building is flat, it is denominated a *platform*, technically, and not a roof. For a full and exact description of every kind of roof, we must refer the reader to Nicholson's *Practical Builder*, contenting ourselves by presenting to him a very elegant and

economical arrangement for a pediment roof, recently designed by A. H. Houldsworth, Esq., for the presentation of a model of which to the Society of Arts, &c., that gentleman was awarded an honorary medal. It is represented in the cut.

The advantages which this method affords, are, the saving of a considerable proportion of the timber usually employed, and the gaining for useful purposes the whole space that is contained within the roof. Mr. Houldsworth constructed a roof of this kind over the dwelling-house of a friend of his, and notwithstanding his walls were only six feet above his upper floor, he has obtained, in consequence, good lofty rooms, whilst the outside of his house appears very low; his barns, hay-lofts, &c., are built upon the same plan. A A represent the walls of the house, and B one of the timbers of the uppermost floor, resting on the sleepers *ff*, which are let into the wall; over two other sleepers, laid in the top of the wall, are fitted two pieces of wood, D D. The principal rafters C C, forming each pair, are then secured at the bottom into the pieces D D, and are fastened to each other at the top by iron pins. Each pair of the principal rafters C C is supported by two arch pieces E E; these pieces are in *their grain*, and are formed on the plan recommended by Mr. Hookey, of the King's Yard, at Woolwich, to whom the country is so much indebted for this mode of converting the timber. They are cut lengthways, by a saw, into three pieces, to within two feet of one end; are then placed in a steam-kiln, and boiled until they will bend freely, when they are fixed to a mould and left to cool; after which a few pins of wood are driven through them, to keep the pieces so cut from again flying open. The arch pieces will get a little out of shape when taken from the mould, but will be easily brought back, and when secured under the principal rafters, will fit the more firmly. The lower ends of these arch pieces are inserted in the beam B of the floor, and therein firmly pinned, while at the top they cross one another, and each butts against its opposite rafter. They are further secured by iron straps to the short pieces D D, on which the principal rafters rest, thus preventing the latter from sinking, and thrusting out the walls, and making the whole a stiff and complete framing, on which the longitudinal rafters and transverse pieces are fastened in the usual manner.

The roofs of barns or other buildings that have only a ground floor, may be constructed in the same way, care being always taken to bring the feet of the arch pieces so far down the wall as to give them a firm bearing.

Mr. Houldsworth, having already constructed several roofs of great widths on the plan described, expresses his entire confidence of being able to apply the same principle to a roof of any given span, for which timber of sufficient length could be procured. This elegant improvement, which does away with all those inconvenient timbers in roofs of the ordinary construction, called king-posts, queen-posts, braces, &c. &c., consequently leaves the whole space (as before observed), which is usually employed to no useful purpose, for the making of good lofty rooms, besides effecting a considerable saving on timber. Numerous examples of the modes of trussing girders for roofs are given under the article BEAM.

**ROPE-MAKING.** The art of forming fibrous, flexible, and tenacious substances into cordage. The principal aim of the ropemaker is to unite the strength of a great number of fibres. This would be done most effectually, were the fibres long enough, by laying them parallel to each other, and fastening the bundle at each end. They must therefore be combined together in such a manner that the strength of any single fibre shall be insufficient to overcome the resistance of the friction occasioned by the entanglement, but rather break: and this effect is found to be produced most easily by twisting them together, so that they shall mutually compress each other. On the other hand, a skein may be twisted so hard, that any attempt at farther twisting will break it; such a skein can have no strength to support a weight, each fibre being already loaded as much as it can bear, and therefore any weight added would break it. Whatever force is actually exerted by a twisted fibre, in order that it may sufficiently compress the rest to hinder them from being drawn out, must be considered as a weight hanging on that fibre, and must be deducted from its absolute strength



of cohesion before the strength of the skein can be estimated. The strength of the skein is evidently the remainder of the absolute strength of the fibres after the force exerted in twisting them has been deducted. Hence arises that fundamental principle in rope-making, namely, that all twisting beyond what is necessary for preventing the fibres from being drawn out without breaking, diminishes the strength of the cordage, and is, therefore, to be avoided. Thus it is necessary to twist the fibres of hemp together, in order to make a strand; but twisting is not all: something must be done to prevent the skein from again untwisting as soon as it is let loose from the hand; some method must be adopted to make the tendency to untwist in one part, act against and counter-balance the like tendency to untwist in another; in the properly accomplishing this, consists one of the principal difficulties of rope-making. The following observations, for distinctness' sake, apply chiefly to the larger cordage, such as forms the standing and running rigging of a ship; but they are easily extended, with proper modifications, to the smaller kinds.

The first part of the rope-making process consists in twisting the hemp; that is, making rope-yarns. These are spun in various ways, according to the nature of the machinery employed, and the cordage to be made. A slip of level ground is enclosed, of about 600 feet long, of a breadth sufficient to contain the number of machines employed, and either covered with a slight roof, or left open at top. A spinning-wheel is set up at the upper end of this walk. The band of this wheel goes over several rollers called whirls, turning on pivots in brass holes. The pivots at one end come through the frame, and terminate in little hooks. The wheel being turned by a winch, gives motion to all these whirls. The spinner has a bundle of dressed hemp round his waist, laid in the same way that women spread the flax on the distaff. He draws out a proper number of fibres, twists them with his fingers, and affixes them to the hook of a whirl. The wheel is now turned, the skein is twisted, becoming what is called a rope-yarn, and the spinner walks backwards down the rope-walk. The spinner supports the yarn in one hand (protected by a wetted piece of coarse cloth or flannel), while with the other he regulates the quantity of fibres drawn from the bundle of hemp by the motion of the twisting yarn. The greatest fault that can be committed, is to allow a small thread to be twisted off from one side of the hemp, and then to cover this with hemp supplied from the other side; for it is evident that the fibres of the central thread make very long spirals, while the skein of the fibres which covers it must be much more oblique. This covering has but little connexion with what is below it, and will easily be detached. But even while it remains, the yarn cannot be strong, for on pulling it, the middle part, which lies the straightest, must bear all the strain. This defect will always happen if the hemp be supplied in a considerable body to a yarn that is then spinning small. Into whatever part of the yarn it is made to enter, it becomes a sort of loosely connected wrapper. A good spinner, therefore, endeavours always to supply the hemp in the form of a thin, flat skein. The degree of twist depends on the rate of the wheel's motion, combined with the retrograde walk of the spinner. We may suppose him arrived at the lower end of the walk, or as far as necessary for the length of the yarn; he calls out and another spinner immediately detaches the yarn from the hook of the whirl, gives it to another, who carries it aside to the reel, and this second spinner attaches his own hemp to the whirl-hook. In the mean time, the first spinner keeps fast hold of the end of his yarn; for the hemp, being dry, is very elastic, and if he were to let it go out of his hand, it would instantly untwist. He waits, therefore, till the reeler begins to turn the reel, and then walks slowly up the walk, keeping the yarn of an equal tightness all the way.

Rope-yarns, for large rigging, are from a quarter of an inch to somewhat more than the third of an inch in circumference; or of such a size, that 160 fathoms of white yarn weigh from  $3\frac{1}{2}$  to 4 pounds. The number of yarns in a strand of cordage varies from sixteen to twenty-five. The yarns are made into cords of any length, by laying them; and that we may have a rope of any degree of strength, many yarns are united into one strand, for the same reason that many fibres are united into one yarn.

The process for laying or closing large cordage, is as follows:—At the upper end of the walk is fixed a tackle-board. This consists of a strong oaken plank, called a breast-board, having several holes in it, fitted with brass or iron plates. Into these are put iron cranks called heavers, which have forelocks and keys, on the ends of their spindles. This breast-board is fixed to the top of strong posts, and well secured by struts or braces. At the lower end of the rope-walk is a similar breast-board fixed to a movable sledge, which may be loaded with weights when necessary. A top, which is a truncated cone, having scores in its sides for the strands, a long staff, and supported on a sledge or carriage, is placed between the strands, and, when necessary, gently forced into the angle formed by their separation. A piece of soft rope, called a strap, is attached to the handle of the top, by the middle, and its two ends are brought back, wrapped several times tight round the rope, and bound down. The yarns are formed into strands, each of which is knotted apart at both ends. The knots at their upper ends are made fast to the hooks of the cranks in the tackle-board; and those at the lower end, to the cranks on the sledge. The sledge itself is kept in its place by a tackle, and a proper weight laid on it till the strands are stretched in their places. The tackle is now cast off, the cranks turned at both ends, and as the strands contract by the operation, the sledge is dragged up the walk. When the strands are sufficiently hardened, they are taken off the cranks, the cranks taken out, and a very strong crank put in the centre hole of the tackle-board. To this all the strands are now attached; the top is placed between the strands, as before described, and the heavers at the tackle-board and sledge continue to turn as before. By the motion of the sledge-crank, the top is forced away from the knot, and the rope begins to close. As this advances, the rope shortens, and the sledge is dragged up the walk. The top moves faster, and at last reaches the upper end of the walk, the rope being now laid.

Such is the general and essential process of rope-making; and in the course of this process, it is in our power to give the rope a solidity and hardness which makes it less penetrable by water. Some of these purposes are inconsistent with others; and the skill of a rope-maker lies in making the best compensation, so that the rope may, on the whole, be the best in point of strength, pliancy, and duration, that the quantity of hemp in it can produce.

The following rule for judging of the weight which a rope will bear, is not far from the truth. Multiply the circumference in inches by itself, and the fifth of the product will express the number of tons which the rope will carry. Thus, if the rope have 6 inches circumference,  $6 \times 6 = 36$ , the fifth of which is  $7\frac{1}{5}$  tons; apply this to the rope of  $3\frac{1}{2}$  inches, on which Sir Charles Knowles made his experiments,  $3\frac{1}{2} \times 3\frac{1}{2} = 10.25$ ; one-fifth of which is 2.05 tons, or 4,592 pounds. It broke with 4,550. This may suffice for a general account of the mechanical part of the manufacture: but we have taken no notice of the operation of tarring, because it would be no easy task to enumerate all the various methods employed in different rope-works. It is evidently proper to tar in the state of twine or yarn, this being the only way in which the hemp can be uniformly penetrated. The yarn is made to wind off one reel, and having passed through a vessel containing hot tar, it is wound upon another reel, and the superfluous tar is taken off, by passing through a hole surrounded with spongy oakum; or it is tarred in skeins or hauls, which are drawn by a capstern, through the tar kettle.

Tarred cordage, when new, is weaker than white, and the difference increases by keeping. The following experiments were made by M. Du Hamel, at Rochefort, in 1743, on cordage of three inches (French) in circumference, made of the best Riga hemp.

*Made August 8, 1741.*

<i>White.</i>	<i>Tarred.</i>
Broke with 4,500 pounds . . . . .	3,400 pounds
,, 4,900 . . . . .	3,300 ,,
,, 4,800 . . . . .	3,250 ,,

*White.**Tarred.**Made April 25, 1743.*

Broke with 4,600 pounds. . . . .	3,500 pounds
,,    5,000 . . . . .	3,400 ,,

*Made September 3, 1746.*

,,    3,800 . . . . .	3,000 ,,
,,    4,000 . . . . .	2,700 ,,
,,    4,200 . . . . .	2,800 ,,

M. Du Hamel says, that it is decided by experience, 1st. That white cordage in continual service is one-third more durable than tarred. 2d. That it retains its force much longer while kept in store. 3d. That it resists the ordinary injuries of the weather one-fourth longer. Why, then, should cordage be tarred? The answer is, That tarring preserves cables and ground tackle, which are greatly exposed to the alternate action of water and air; for white cordage, exposed to be alternately very wet and dry, is found to be weaker than tarred cordage; and that cordage which is superficially tarred is always stronger than what is tarred throughout, and resists better the alternatives of wet and dry.

**RULE.** An instrument with lines, divisions, and numerals marked upon it, of the greatest utility in mensuration. There are, of course, numerous kinds adapted to their peculiar objects. The most extensively useful is unquestionably the carpenter's rule, for taking lineal measurements, which is therefore divided into feet, inches, and various parts, scales of proportion, &c. There are various sliding rules, for performing computations; others furnished with tables adapted to the use of all kinds of trades and manufactures, as well as professional persons. For rules especially designed for drawing parallel lines, see **PARALLEL RULE.**

## S

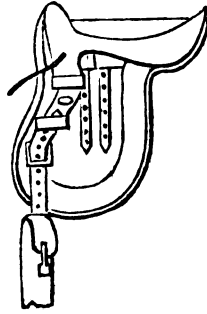
**SACCHAROMETER.** An instrument for ascertaining the strength of worts, in the preparation of malt liquor for beer or distilling spirit; its name, however, simply implies a measurer of saccharine matter or sweetness. See **DISTILLATION.**

**SADDLE.** A seat placed upon a horse's back, for the convenience of the rider. Among the recent patents having this object in view, we shall mention the leading features of two or three of them.

To give increased elasticity to the seats of saddles, Mr. Marsh employs fine wire springs, in lieu of the wool and other materials generally used in stuffing them, which are apt, by the compression of the rider, to become hard. The springs are of the kind used in garters and elastic braces. They are extended in rows from the front to the back of the saddle, upon the ordinary packing, and secured by sewing their ends to a web which is attached to the saddle. When this is done, the usual coating of cloth is put over the wire springs, and fastened down upon the covering of the packing below, by stitching in lines at small distances apart, crosswise of the saddle, by which means the rows of wire will be kept alongside of each other, and preventing from overlapping. The external covering forming the seat being now placed over the springs, and finished in the usual way, an elastic seat is produced, which, it is said, is much superior to any kind of packing before used.

Mr. Henry Calvert, of Lincoln, had a patent in 1830, the object of which was to avoid the inconvenience and danger occasioned by saddles slipping

forward. The annexed cut represents one of Mr. Calvert's, with the exterior cover and flap removed to show the construction. The improvement mainly consists in attaching to the fore part of the saddle-tree an elastic plate of metal extending in a sloping direction towards the front of the saddle; it is confined by two loops, which receive the girth strap; the proper shape of the sweat-flap is also shown. The small buckle which is fixed to the loose end of the girth is drawn up to the small strap after the horse is girthed. The front girth of course is strapped first, and the second not quite so tight. By this arrangement it will be seen that the saddle is kept in its place by the elasticity of the metal plate, and that it cannot move forward upon the horse without the girth being lengthened.



Messrs. Laurence and Rudder had a patent in the succeeding year for "an improvement in saddles and girths by an apparatus fixed to either of them;" the object of which was to give to saddle-girths an elasticity to preserve sufficient tension under the varying dimensions of the animals to which they may be applied. Saddle-girths, for instance, that have been put on immediately after the horse has been fed, must either be made inconveniently tight at first, or else they will become inconveniently loose as the size of the animal diminishes by the digestion of his food. The patentees denominate their girths the *constrictor* girths, and they are made by attaching to the saddle-tree by a pair of hinges a small shallow brass case containing a series of grasshopper springs, and behind the springs is a movable plate, to which the girth-straps are attached in such manner that when the movable plate is pulled down by the girth-straps the springs are collapsed, or brought into a position to exert their elasticity in preserving the tightness of the girth.

**SAFFRON.** The stigmata of the *crocus officinalis*, dried on a kiln, and pressed into cakes. The best saffron has the broadest blades,—this being the mark by which English saffron is distinguished from the foreign; it ought to be of an orange or fiery-red colour, and to yield a dark yellow tincture; it should be chosen fresh, not above a year old, in close cakes, neither dry nor yet very moist, tough and firm in tearing, of the same colour within as without, and of a strong, acrid, diffusive smell. This drug has been reckoned a very elegant and useful aromatic; it imparts the whole of its virtue and colour to rectified spirit, proof spirit, wine, vinegar, and water. A tincture drawn with vinegar loses greatly of its colour in keeping; the watery and vinous tinctures are apt to grow sour, and then lose their colour also; that made in pure spirit keeps in perfection for many years.

**SAGO.** A nutritive substance, brought from the East Indies, of considerable use in diet as a restorative. Sago is procured from a tree called landau, growing in the Moluccas: this tree is a species of the palm, which grows naturally in Japan, and upon rocky, dry mountains in Malabar, and its production is an universal article of food among the inhabitants of Amboyna, Ceram, Celebes, and the surrounding islands east of Celebes, and also in Borneo. The progress of its vegetation, in the early stages, is very slow: at first, it is a mere shrub, thick set with thorns, which make it difficult to come near it; but as soon as its stem is once formed, it rises in a short time to the height of thirty feet, is about six feet in circumference, and imperceptibly loses its thorns. Its ligneous bark is about an inch in thickness, and covers a multitude of long fibres, which, being interwoven one with another, envelope a mass of a gummy kind of meal. As soon as this tree is ripe, a whitish dust, which transpires through the pores of the leaves, and adheres to their extremities, proclaims its maturity. The Malays then cut them down near the root, divide them into several sections, which they split into quarters; they then scoop out the mass of mealy substance, which is enveloped by, and adheres to, the fibres; they dilute it in pure

water, and then pass it through a straining bag of fine cloth, in order to separate it from the fibres. When this paste has lost part of its moisture by evaporation, the Malays throw it into a kind of earthen vessels, of different shapes, when they allow it to dry and harden. This paste is a wholesome, nourishing food, and may be preserved for many years; the Indians eat it diluted with water, and sometimes baked or boiled: a jelly is sometimes made of it, which is white and of a delicious flavour. The finest part of the meal is mixed with water, and the paste is rubbed into little round grains like small shot, and dried. This is the sago of the shops.

**SAL.** The Latin name for salt, commonly adopted in chemical language as in the following examples, which require explanations:—

*Sal-alembroth*, a compound muriate of mercury and ammonia.

*Sal-ammoniac*, muriate of ammonia.

*Sal-ammoniac, secret*, sulphate of ammonia.

*Sal de Duobus*, sulphate of potash.

*Sal-gem*, native muriate of soda.

*Sal-martis*, green sulphate of iron.

*Sal-prunella*, nitrate of potash.]

**SALIFIABLE BASES.** Those metallic, earthy, or alkaline substances, which have the power of neutralizing acidity entirely or in part, and producing salts.

**SALT.** A term commonly used in chemistry to denote a compound in definite proportions, formed by the union of an acid with an alkaline, earthy, or metallic base. We have already given a brief enumeration of some of the most remarkable, under the article **CHEMISTRY**. In consequence, however, of the progressive discoveries which for the last half century have been continually made, and are still making, in chemistry, many deductions, which, at the time they were made, were considered as conclusive facts, have since been either wholly abandoned, or subjected to considerable modifications. A salt has usually been denominated by chemists a *neutral* salt, when the proportions of the constituents are so adjusted, that the resulting substance does not affect the colour of infusion of litmus or red cabbage. When the predominancy of acid is evinced by the reddening of these infusions, the salt is said to be *acidulous*, and the prefix *super*, or *bi*, is used to indicate the excess of acid: thus we call one particular salt *super-tartrate* of potash, and another, *bi-sulphate* of lime, where the acid exists in excess. But when, on the contrary, the acid matter is in too small a quantity to completely neutralize the alkalinity of the base, the salt is said to be with an excess of base, and the prefix *sub* is attached to its name: thus we have the *sub-phosphate* of bismuth, &c.

The commercial name of a salt differs from that by which it is known to chemists: it may therefore be proper to show what kinds of salt are to be understood by the popular names which they bear in the shops.

*Ammoniacal Mixed Salt*, muriate of lime.

*Ammoniacal Secret Salt of Glauber*, sulphate of ammonia.

*Arsenical Neutral Salt of Macquer*, super-arsenate of potash.

*Bitter Cathartic Salt*, sulphate of magnesia.

*Common Table Salt*, muriate of soda.

*Digestive Salt of Sylvius*, or *Diuretic Salt*, acetate of potash.

*Epsom Salt*, sulphate of magnesia.

*Febrifuge Salt of Sylvius*, muriate of potash.

*Fusible Salt*, phosphate of ammonia.

*Fusible Salt of Urine*, triple-phosphate of soda and ammonia.

*Glauber's Salt*, sulphate of soda.

*Marine Salt*, muriate of soda.

*Marine Argillaceous Salt*, muriate of alumina.

*Microcosmic Salt*, triple-phosphate of soda and ammonia.

*Nitrous Ammoniacal Salt*, nitrate of ammonia.

*Salt of Amber*, succinic acid.

*Salt of Benzoin*, benzoic acid.

*Salt of Canal*, sulphate of magnesia.

*Salt of Colcothar*, sulphate of iron.

*Salt of Egra*, sulphate of magnesia.

*Essential Salt of Lemons*, super-oxalate of potash.

*Salt of Saturn*, acetate of lead.

*Salt of Seidlitz*, sulphate of magnesia.

*Salt of Seignette*, triple-tartrate of potash and soda.

*Salt of Soda*, sub-carbonate of soda.

*Salt of Surrel*, super-oxalate of potash.

*Salt of Tartar*, sub-carbonate of potash.

*Salt of Vitriol*, purified sulphate of zinc.

*Salt of Wisdom*, a compound-muriate of mercury and ammonia.

*Perlate Salt*, phosphate of soda.

*Polychrest Salt of Glauber*, sulphate of potash.

*Sedative Salt*, boracic acid.

*Spirit of Salt*, muriatic acid.

*Sulphureous Salt of Stahl*, sulphate of potash.

*Wonderful Salt*, sulphate of soda.

*Wonderful Perlate Salt*, phosphate of soda.

**SALT, Culinary**; is in chemical language the muriate of soda: but according to recent discoveries, a chloride of sodium, being a compound of chlorine, with the metallic base of soda. This salt is obtained by a variety of methods. It is either dug out of the earth in a solid form, and dissolved, purified, and evaporated for use; or sea-water is evaporated, either by natural or artificial means, and salt is obtained from the purified residuum. The most abundant supply of rock-salt in this country is obtained from the mines in Cheshire, where the brine is pumped up from the brine-pits, saturated with rock-salt, and then boiled. One hundred tons of the saturated solution of rock-salt in sea-water will be found to yield about twenty-three tons of salt.

The celebrated mines of Poland, whence the rock-salt has been continually abstracted in immense quantities for a period of upwards of five hundred years, where, at times, they have 20,000 tons ready for sale, is, however, not so productive as those in Cheshire. At Cordova, in Spain, there is a mountain of pure rock-salt, from 400 to 500 feet high, and a league in circuit; the depth below the surface of the ground is unknown. In Louisiana, near the river Missouri, there is said to be a mountain of pure rock-salt of the best quality, which is 80 miles long, 45 miles wide, and of an immense height.

The waters of the ocean every where abound with common salt, though in different proportions: the average has been calculated to be about one-thirtieth of its weight. In the cold climates, the quantity of salt in the sea-water does not appear to be nearly so great as between the tropics. In Russia, and other northern countries, the salt is usually obtained from the sea-water, by freezing the latter; the ice, which is nearly fresh, being then removed, the remaining brine is very strong, and is subsequently evaporated by boiling. In the southern parts of Europe, and other warm countries, the usual mode of obtaining the salt is by spontaneous evaporation. A flat piece of ground near the sea is chosen, and banked round, to prevent its being overflowed at high water. The space within the banks is divided by low walls into several compartments, which successively communicate with each other. At flood tide, the first of these is filled with sea-water; which, by remaining a certain time, deposits its impurities, and loses part of its aqueous fluid. The residue is then suffered to run into the next compartment, and the former is filled again as before. From the second compartment, after a due time, the water is transferred into a third, which is lined with clay, well rammed and levelled. At this period, the evaporation is usually brought to that degree, that a crust of salt is formed on the surface of the water, which the workmen break, and it immediately falls to the bottom. They continue to do this until the quantity is sufficient to be raked out and dried in heaps: this is called *bay-salt*.

In several parts of France, and on the coast of China, the sands of the sea-shore are washed, and the brine thus obtained is subsequently evaporated in boilers. In various places of Germany and France, the salt waters are pumped

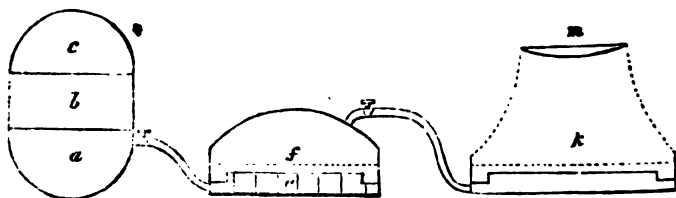
up to the top of very extensive sheds, filled with brushwood, over which it is duly distributed by means of gutters, whence, falling in drops from sprig to sprig, a rapid evaporation takes place over an immense surface; the same water is pumped up many times before it is sufficiently concentrated to be drawn off into boilers, which complete the operation. See an account of several works of this kind in Dr. Ure's Dictionary of Chemistry.

Under the article *EVAPORATION*, we have given several ingenious illustrations of the process of "Salt-making." In this place we shall add a notice of two or three more recent inventions.

Messrs. Jump and Coart's patent method consists in concentrating the salt water, by a simple arrangement, previous to its entering the pans. For this purpose, the reservoir of salt water is elevated above the pans, and the pipe which supplies them with the brine first passes through all the furnaces beneath, which brings the liquid quickly to a boiling temperature, in which state it is discharged, by means of a curved pipe, into the pans above, thereby greatly facilitating and abridging the process of concentration. A stop-cock is placed in the supply-pipe, so that, as often as it is desired to replenish the pan, this cock is opened, and the superincumbent pressure of the water in the reservoir forces out the boiling brine from the pipe into the pan, the pipe receiving, in lieu thereof, the cold liquid from the reservoir.

Mr. Johnson, of Droitwich, according to his patent of 1827, employs steam of different degrees of heat to produce the evaporation in pans closed from the atmosphere, so that the vapour arising from the first pan, where the *fine salt* is produced, is employed in heating the second, where the *broad salt* is formed: and the vapour arising from the latter is employed in like manner, to produce in the third pan British bay-salt.

A sketch of the steam boiler is represented in the annexed drawing, divided into three portions, *a*, *b*, and *c*; and steam is generated in one or more of



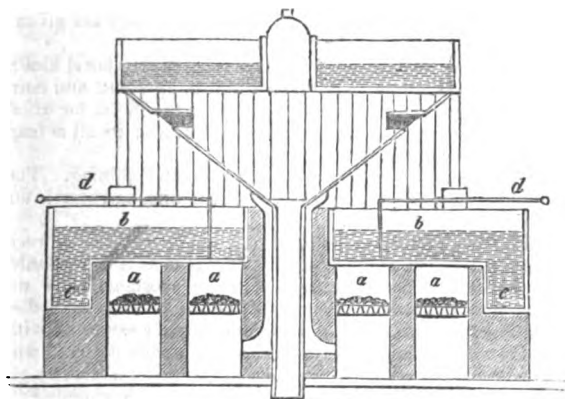
these divisions, according to the supply required. When the steam in *a* is raised to a pressure of twenty-five pounds on the square inch, that in *b* will be twelve, and that in *c* five pounds. When only one of the divisions, *a*, of a steam-boiler about seventeen feet by ten is employed, it will heat pans to the extent of 2,400 square feet up to 164° Fahr. : and when the three divisions, *a*, *b*, and *c*, are used together, an extent of 4,300 square feet will be heated to the same temperature.

The steam is conveyed in a pipe from the boiler to a steam-vessel *e*, under the fine salt-pan *f*. This pan is made steam-tight, and the steam arising therein is conveyed by a pipe to a similar vessel under the broad salt-pan *k*. Over the broad salt-pan *k* is placed the bay salt-pan *m*, and the space between them is enclosed by thin boards, or other light material, to confine the vapour arising from *k*, in order to produce the required heat in the pan *m*. This pan is made lowest in the middle, as represented in the drawing, so that water condensed on its lowest surface may be collected in one place, where it is received and carried off in a spout, to prevent its return into the brine in the lower pan *k*.

The patentee considers it of great importance to keep the bottom of the pans

clear of salt; and for that purpose employs rakes, which are kept constantly in motion by a steam engine. These rakes deposit the salt in receptacles at the sides of the pans. The rods by which the rakes are moved pass through stuffing boxes in the pans, to prevent the escape of steam.

Mr. Furnival, a spirited manufacturer of salt on an extensive scale, has taken out several patents for improvements in the mechanical arrangements of the process. His last patent, which embodies the leading characteristics of his previous plans, may be explained with reference to the annexed diagram, which



represents a vertical section of the apparatus, with two tiers of pans. *a a a a* are four furnaces, the flues from which are extended under a considerable range or surface of the pans, which are of the shape represented at *b c*, the deep part *c* being made to receive the salt thrown over by the ebullition, and also such portion as may be scraped from the surface of *b*, by means of the instruments shown at *d d*. The deep chambers being removed from the direct action of the fire, prevent the salt deposited therein from becoming burned; and these receptacles, being at the sides, the salt is conveniently scooped out. The steam raised from the lower range of pans is then employed to heat an upper range *e e* of less area, supported upon suitable framing, lined interiorly, to confine the steam, with boards. In order that the water resulting from the condensation of the steam against the bottoms of the upper pans, may not fall back into the lower pans, two inclined planes are formed, which receive the condensed water, and conduct it into a pipe, whence it is carried off by a gutter underneath. In these inclined planes suitable apertures are made for the passage of the ascending steam from the lower to the upper boilers.

The patentee also proposes to heat a third set of pans above the second; for this purpose there is a central aperture to conduct the steam to them; this aperture is covered with a cap.

**SAPPHIRE.** A precious stone, of which there are several varieties; next to diamond, it is considered the most valuable of gems. The white and pale blue varieties, by exposure to heat, become snow white, and, when cut, exhibit so high a degree of lustre, that they are used in place of diamond. The most highly prized varieties are the crimson and carmine red; these are the oriental *ruby* of the jeweller; the next is *sapphire*; and last, the yellow, or oriental *topaz*. The *asterias*, or star stone, is a very beautiful variety, of which the colour is generally violet-red, and the form a rhomboid, with truncated apices, which exhibit an opalescent lustre. A sapphire of ten carats' weight is considered to be worth fifty guineas. An *oriental ruby* of thirty carats, without flaws, and of a perfect colour, is considered almost as valuable as a diamond of the same weight.



**SARDONYX.** A precious stone, consisting of a mixture of chalcedony and cornelian, sometimes in strata, but at other times blended together. It is found, first, striped with white and red strata, which may be cut in cameo as well as the onyx. Second; white, with red dentritical figures, much resembling the mocha-stone, excepting that the figures in the latter are of a black colour, instead of a red. There is no real difference, except in the circumstance of hardness, between the onyx, cornelian, chalcedony, sardonyx, and agate, notwithstanding the different names bestowed upon them. This stone was formerly much employed for the sculpture of cameos.

**SARSAPARILLA.** A medicinal root, obtained from Peru: it consists of a great number of long strings, hanging from one head; they are given in decoction, as a diet drink.

**SASSAFRAS.** The wood of an American tree, of the laurel kind, imported in large straight blocks; it is said to be "warm, aperient, and corroborant," and to be often successfully employed in purifying the blood, for which purpose an infusion, in the way of tea, is a very pleasant drink; its oil is fragrant, and possesses most of the virtues of the wood.

**SATIN.** A kind of silken stuff, very smooth and shining. The wool is coarse, and hidden underneath the warp, which is fine, and stands out, and on this depends its gloss and beauty.

**SATURATION.** The act of imbibing till no more can be received. A fluid that holds in solution as much of any substance as it can dissolve, is said to be saturated with it. But saturation with one substance does not deprive the fluid of its power of acting on, and dissolving some other bodies, and in many cases it increases this power. For example, water saturated with common salt will dissolve sugar; and water saturated with carbonic acid will dissolve iron, though without this addition its action on this metal is scarcely perceptible. The word saturation is likewise used in another sense by chemists: the union of two principles produces a body, the properties of which differ from those of its component parts, but resemble those of the predominating principle. When the principles are in such proportion that neither predominates, they are said to be saturated with each other; but, if otherwise, the more predominant principle is said to be sub-saturated, or under-saturated, and the other super-saturated, or over-saturated.

**SAWS, AND SAW-MILLS.** A saw is a cutting instrument, with a serrated edge; a saw-mill, a machine or building, wherein several or many of these instruments are actuated by horse, wind, steam, water, or other power.

It was not until the seventeenth century that saw-mills were introduced into England, attended with the most violent opposition from the sawyers, who apprehended they would be the means of depriving them of their subsistence. Some that were undertaken were abandoned at the outset, and others were destroyed by the populace.

The saw-mills of the present day are of two distinct kinds; the *circular*, those that cut by a continuous rotatory motion, and the *reciprocating*, which operate as the common pit or frame-saw. The *circular saw-mills* are for the most part used for cutting up timber of small dimensions; and the *reciprocating* for large timber, in forming beams, rafters, planks, &c., out of large timber. The most important machinery of the kind was erected by Mr. Brunel, at Portsmouth, to whom the mechanical world is indebted for many important inventions and improvements.

Saws are made of a great variety of forms and sizes, to adapt them to the materials on which they are designed to operate. The most common are those used by carpenters, who require in ordinary no less than ten different saws; namely, a *cross-cut saw*, for dividing a tree or log transversely, by means of two workmen, one on each side, who alternately pull the saw towards them, the teeth being made to cut equally in each direction; a *pit-saw*, for sawing the logs up into planks or scantlings, the operation being performed in a pit by a vertical motion of the saw, and usually by a class of workmen called sawyers; a large *frame-saw*, which is a saw-plate five, six, or seven feet long, stretched in a frame, and used to cut timber longitudinally with greater nicety than the

*pit-saw*; a *ripping-saw*, which is a hand-saw, with a blade twenty-eight or thirty inches long, and having large teeth for ripping, or cutting out stuff coarsely and quickly; a *hand-saw* (peculiarly so denominated), usually provided with a twenty-six inch blade, and angular teeth, five to the inch; a *panel-saw* is the same as the hand-saw, but with finer teeth, (seven or eight to the inch,) for cutting stuff very clean, and for the more delicate or exact species of work. Saws with very fine teeth, and very thin blades, stiffened with stout pieces of iron or brass, riveted to the back edge, are also used, of several kinds, which are distinguished by the several terms, *doetail*, *sash*, *carcase*, and *tenon*, indicative of their uses, and also of their sizes, which vary from six to twenty inches in length; several very narrow saws, indifferently called *lock*, *compass*, *key-hole*, and *turning* saws, for cutting out small pieces, and rounding work: small *frame-saws*, six or eight inches long, are sometimes required by the carpenter for cutting both wood and iron; the teeth of the latter being smaller and more obtuse than the former. There are many saws used by other mechanics, which differ from the carpenter's, the details of which would be uninteresting; we shall therefore proceed to take a brief notice of the process of manufacturing saws, as practised at Sheffield, from whence three-fourths of the inhabitants of the globe are supplied.

The very commonest kind of saws are made of iron plates, hammer-hardened, and planished upon an anvil, to give them some degree of stiffness and elasticity. Such instruments are, of course, spurned by the workmen; nevertheless, as their cost is but trifling, they are purchased in great quantities by those who consider any saw to be better than no saw at all.

The more useful saws which workmen employ are made, nominally, of either *shear* or *cast* steel; but the quality of these materials may differ, as well as the saws made of them, in every possible degree. The common test of a good saw, that of bending it into a bow, and letting it spring again into a straight line, is considered by some persons as a fallacious and unnecessary test, and that it sometimes spoils a saw, possessing in other respects all the properties of a valuable tool. A dispute has been raised on this point, and ably advocated on both sides. For our own parts, we would simply observe, that such process of springing infallibly proves *two* of the essential properties of a good saw, namely, uniformity of thickness in the blade, and perfect elasticity.

Experience has shown that cast steel is the best material for making saws, as well as most other tools, on account of the greater uniformity of its structure, which is not lost by the subsequent operations of rendering it malleable and elastic. To prepare this material, the liquid metal is poured into a cast-iron mould, out of which the casting, when cooled, is taken, in the form of a small slab about  $1\frac{1}{2}$  inch thick. This slab is next laminated between rollers until it is extended to the required dimensions. If intended for the larger kind of saws, as mill or pit-saws, the whole piece may be required, in which case it is clipped by shears to the required shape; but if for smaller articles, it is cut up into suitable pieces; the edges are next perfected by filing, and holding the flat side of the plates against large grindstones, which process prepares them for the cutting of the teeth. This operation is usually performed by a die-cutter in a fly-press, the motion of the saw-plate being duly regulated, so that the teeth shall be uniform; the large teeth being cut one at a time; and the smaller, two, three, or more at a time, according to circumstances. The wire edges left on the teeth of the plates by the cutting-out press, are next removed by filing. The operations of hardening and tempering succeed, which require considerable care and attention on the part of the operator. A variety of fatty compositions have been recommended for this purpose, as possessing peculiar efficacy in hardening, amongst which we may instance that recommended by Mr. Gill, who appears to have had considerable experience in matters of the kind, and to be somewhat acquainted with chemical science; we should, otherwise, have taken an exception to the variety of similar ingredients in his caldron. He desires us to melt together 3lbs. of black rosin and 1lb. of pitch, and to these (when melted) one gallon of neatsfoot oil, 20lbs. of beef suet, rendered, and twenty gallons of olive oil. All these are to be heated together in an iron

vessel until the aqueous vapour is driven off, and the composition will take fire by the application of flame to the surface, which is then to be extinguished by placing on the cover of the vessel. The saw-plates being now heated in a reverberating or other suitable furnace to a cherry red, are precipitated edgewise into the liquid mixture just mentioned, contained in a vessel of a proper figure for that purpose, and when sufficiently cooled therein to be handled, they are taken out and are found to be extremely hard and brittle. The unctuous matter which adheres to the plates being next partially removed, they are taken up successively by a pair of tongs, and passed backwards and forwards over a clear charcoal fire, so as to cause the unctuous matter to inflame, or "blaze off," as it is termed, which reduces the saws to the desired temper; and whilst the saw-plates remain hot, any warping they may have acquired in the process is removed by smart blows from a hammer, over an anvil strewn with sand, to prevent the article from slipping about.

The next operation is planishing by hammers, which renders them more even and equally elastic; and the dexterity and care with which this operation (so difficult and tedious to ordinary smiths) is performed, is a remarkable instance of what human art is capable of by long practice.

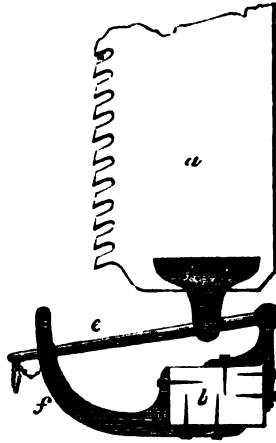
The saws are now ready for the grinder, who applies them to the circular face of a large grindstone, by an interposing board, against which he presses with all his force, so as to grind it as evenly as possible. Standing on tip-toes, he stretches himself over a large grindstone, which is revolving with great rapidity; his hands, arms, breast, and knees, being all brought into operation to produce the effect, while he becomes covered with ochrous sludge, formed by the attrition against the stone; an operation apparently so dangerous and disagreeable, as to give pain to the spectator, and make him wish to see a machine supplying the place of the operator.

The grinding of the saw-plates materially impairs their previous flatness and elasticity; they are, therefore, submitted to a second hammering by the planishers, and are afterwards heated over a coke fire until they attain a faint straw colour, which restores to them their elasticity. The surfaces are next lightly passed over a grindstone, to remove the appearances of the hammer, and next over a fine hard stone, to remove the scratches of the last, and give it the kind of polish required in the market for which the saws are intended. For which purpose the glazing wheel of buff leather and emery, or the "hard head," which is a wheel of hard wood, worked bare, are also used, as occasion may require. To correct any defects that the saws may have acquired during the processes described, they are next "blocked," that is, struck upon a post of hard wood, by means of a small polished hammer, by which the truth of the work is presumed to be perfected.

The saws are next "cleaned off" by women, by means of fine emery rubbed over them lengthways by a piece of cork-wood, which gives them an agreeable, even, white tint, and a very level appearance. They are next handed to the setter, who places each alternate tooth over the edge of a little anvil, in an angular direction, and strikes them so as to bend each uniformly into the required deviation from the plane of the saw; then turning over the saw, the setter strikes, in like manner, the alternate teeth, which he left untouched on the other side; in this manner each successive tooth is placed in opposite directions, at the desired *set*, to allow the blade of the saw to pass through the wood without resistance, while its breadth acts as a guide, and serves to give stability and effect to the operation of sawing. The teeth of the saw are again touched up with a file, to finish their sharpening; for which purpose they are fixed between two plates of lead, contained in the chaps of a vice; after which their handles are fixed by nuts and screws, cleaned off, oiled, and packed in brown paper, for sale.

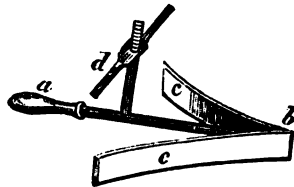
The form or mode of construction of the saws we have described, has been generally found so efficient and useful, as to have needed no material improvements; we shall, therefore, simply notice, in a brief manner, two or three matters of a subordinate character, connected with the subject, which may prove of service to the workman.

A frame-saw, it is well known, can be made thinner than a common pit-saw; and as it works in a smaller kerf, it would effect a considerable saving of timber if it could be employed in lieu of the pit-saw in cutting logs up into thin boards. To effect this object, an ingenious shipwright of Rotherhithe contrived the arrangement represented in the subjoined cut. *a* is the lower end of a frame-saw; *b* a section of the lower bar of the frame; *c* the holdfast; *d d* the two pins; *e* the lever; *f* a double arch, pierced with holes, the lever working between the two parts of the arch; the saw can be held to any degree of tightness by a small peg, fastened by a chain to the end of the lever. To shift this saw, press the lever, take out the peg, lift up the lever, take out the two pins *d d*, and the saw being lifted, and swung back, can be put in the next cut, and again fastened.



In operating with a common frame-saw, it would be necessary, at every successive cut, to shift all the transoms behind the saw to the end of the piece, or it would be necessary to take the saw out of the frame, when a difficulty would arise of fixing it again tightly. Both these objections are obviated by the plan we have described; and by which, long deals, planks, and boards, may be cut with an important saving of material.

An expanding wedge for the use of sawyers, represented in the subjoined sketch, was invented by Mr. T. Griffiths, of the Royal Institution, and was deemed worthy of an honorary medal from the Society of Arts. *a* is the handle or centre-piece, to which is connected two springs *c c*, joined together at *b*; the handle also carries a cross piece *d*. This instrument is intended to save the time and trouble of shifting the common wedges, while sawing up balks of fir into deals. When the saw



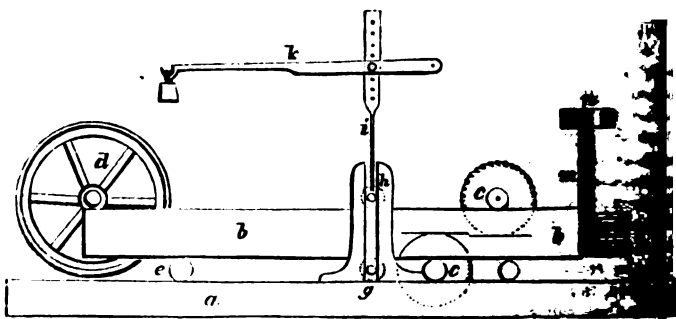
has cut two or three feet, the loose ends of the springs *c c* are to be brought by hand as near to the centre piece *a* as their elasticity will admit; the end *b* is then to be introduced into the cut, and the wedge is to be thrust up to the end of the spring, the cross piece *d* resting on the upper surface of the balk. The elasticity of the springs will then be continually opening the cut as the saw proceeds, to the length of about twelve feet; and the wedge, when at its utmost expansion, will be prevented, by the cross piece, from falling into the pit.

In the ordinary saw-mill, the saws are stretched in a wooden frame, which slides up and down within another frame, in a similar manner to a window sash: the motion is given to it by a crank, attached to a fly-wheel upon the main axis, made to revolve by a water-wheel, or other power, and connected by gear that will give four or five revolutions of the crank to one of the water wheel. The timber is fastened upon a carriage, which is a horizontal frame, sliding or rolling between guides on the floor of the mill, and of such dimensions as to pass between the vertical frame, proceeding by a regulated motion, and constantly presenting the timber to the action of the saws. The saws are so fitted in the frame that they can be removed in a few minutes, and replaced by another set of sharpened saws.

Considerable improvements have been made upon saw-mills by Mr. Brunel, Mr. Maudslay, and many other engineers, who have, of late years, been

engaged in their construction. The introduction of circular saws, which act by a continual rotary motion, formed an important era in sawing machinery, from the great facility, precision, and rapidity of its operation. A saw-mill of this kind has been employed for many years at the manufactory of the ingenious Mr. George Smart, near Westminster Bridge. In this, motion is imparted to a horizontal shaft, on which is a spur-wheel that turns a pinion on another horizontal shaft; on this second shaft, the bearings of the gudgeons of which are supported on the joists of the floor above, is a band-wheel, which communicates motion, by an endless strap, to a pulley fixed on the spindle of the circular saw, and causes the latter to revolve with great rapidity. The ends of the spindle are conically pointed, and the end nearest to the saw turns in a cavity made in the end of a screw, whose nut is fixed, and has a firm bearing in a stout bench; the other end turns in a similar screw, passed through a cross beam, mortised between two vertical beams, extending from the floor to the ceiling; one of the beams can be raised or lowered in its mortises by wedges put both above and below its tenons. In order to adjust the plane of the saw to the plane of the bench, there is a long parallel ruler, which can be set at any distance from the saw, and fixed by means of screws going through circular grooves cut through the bench. In using the machine, the ruler is to be set the proper distance from the saw, according to the piece of wood to be cut; and as the saw turns round, a workman slides the end of a piece of wood to it, keeping its edge against the guide or ruler, that it may cut straight. The operation is, of course, very expeditious and accurate. Lathes are now frequently fitted up with circular saws.

Some improvements in mechanism of the latter kind were patented by Messrs. Sayner and Greenwood, in 1824, which we shall here describe. The first improvement mentioned in the specification relates to the adaptation of two circular saws operating together, instead of one, to cut through a piece of timber. By the usual process, it requires a circular saw of five feet in diameter, to cut through a log of two feet in diameter, in consequence of the obstruction of the axis and supporting shoulders; but by the application of two saws of little more than half the diameter of the single large saw, one above the log and the other under, each making an incision rather more than half way through, the division is effected with a considerable saving of power, and of the cost of saws. The annexed diagram is designed to explain the mechanical



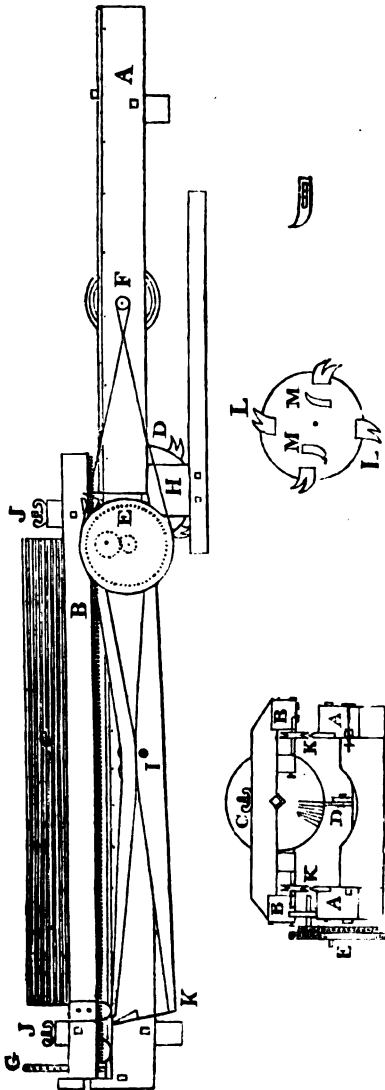
arrangement. *aa* is the bed of the saw-mill; *bb* the log of timber under operation; *cc* the two circular saws, the depths of their respective cuts being expressed by two right lines forming tangents to their peripheries; these saws have pulleys upon their axes, and are driven by endless bands embracing them and the drum-wheel *d*, to which motion is given by a water-wheel, or other adequate mechanical agency. The timber rests and moves upon horizontal

rollers *e e*, and is accurately guided to the saws by vertical rollers, not introduced into the figure, as they are common to other saw-mills. The axes of the saws run in fixed bearings, and the timber is forced against them by the revolution of the propelling roller *g*, put in motion by another band from the drum-wheel *d*, the axis of the roller being confined by an upright frame *g h*; in the upper part of which frame turns the pressing roller *h*, which being connected to the vertical bar *i*, is pressed upon by the weighted lever *k*; the roller *g* therefore gives the motion, and the roller *h* a steady firmness to the advancing position of the log.

If the timber is to be cut into planks, a number of circular saws are placed together on the axes *c c*, with flanges between them of the thickness of the required planks, and then bolted together; by these means the whole log is at one operation formed into boards; and if it be required to cut the logs into scantlings or laths, a series of horizontal saws *l*, placed in like manner upon a vertical axis *m*, and driven by a pulley *n*, cuts the whole at once into those small divisions. This mode of applying the saws to work in a horizontal plane so as to operate simultaneously with those acting in a vertical direction, forms the second improvement claimed under the patent right.

A third improvement claimed, is for uniting the plates of a series of circular saws closely together, so as to make one compact body of saws, without any interstices between them, for the purpose of reducing dye-woods entirely to saw-dust or powder, instead of the usual method of chipping or rasping them for dyeing or other purposes.

A few years ago (about 1824), Mr. Robert Eastman, of Brunswick Maine, U. S., invented some improvements in the construction of circular saws, and in the mode of sawing "lumber" (timber), which obtained extensive adoption in America; and as we think them extremely interesting, and that their adoption in this country would tend to beneficial results, we shall here annex the description, and the intelligent inventor's remarks upon the subject. Instead of a continued series of teeth all round the periphery of the plate, like other circular saws, Mr. Eastman's has only eight, or rather it may be said to have only four cutting instruments, each containing two teeth, which are placed at equal distances on the circumference,



and projecting from it; these instruments are called "section teeth." The saving of labour in consequence of this form of saw is calculated at full three-fourths; and the surface of the timber is much smoother than when cut by the full-teethed saw. On the saw-plate are also fixed instruments called "sappers," which, being placed nearer to the centre, do not enter the wood so deeply as the saw, and are adjusted so as merely to cut off the extraneous sap part, rendering the edges of the planks uniformly straight, and all the cuts of equal dimensions. To understand which, it is, perhaps, necessary here to explain to the reader that the logs are, by this machinery, cut up lengthwise, *not through the log*, but from the circumference, or exterior, to the centre, as the radii of a circle, it having been ascertained that planks, staves of casks, &c., cut out in this manner, possess much more durability, strength, and elasticity, than by the common method. *Fig. 1* represents a side view of the machine, with a log in it ready for working. *Fig. 2* is an end view of the same, exhibiting the log partly cut into sections. *Fig. 3* is the saw, with its section teeth L L L L, and its sappers M M. *Fig. 4* shows the shape of the sapper, with a groove, or slit, to admit of its being set according to the intended width of the plank.

A, *Fig. 1*, is a strong frame of timber, about twenty-four feet long, by five broad, the ends of which are seen at A A, *Fig. 2*. B, *Fig. 1*, is the carriage, about twelve feet long, and four broad, the ends of which are seen at B B, *Fig. 2*; it travels upon iron truck-wheels, grooved on their circumferences, and run upon iron slides, as shown at K K, *Fig. 2*. C, *Figs. 1 and 2*, gives two views of the log under operation.

The log is fixed into the carriage by means of iron centres, upon which it also revolves, after each succeeding cut. At D D, *Figs. 1 and 2*, is seen part of the saw. At E E, *Figs. 1 and 2*, are situated the feed pulley, and shifting gear F, regulating pulleys. G is an index for regulating the dimensions of the cuts. H, revolving levers and pins. I, the pin and fulcrum of the levers. J J, the stirrup screws and pins.

Nearly in the middle of the frame is fixed the *main shaft*, of cast iron, which runs upon friction rollers, supported by stands on the floor. On this shaft is the saw, with its sappers and section-teeth. The motion is given by a band passing round the main pulley, and round a drum that runs under it; which may be driven by horse, steam, or water power. The method by which the saw is fed with the wood to be cut, and the return of the carriage for the succeeding cut, is too similar to our own to need a particular description. Its various arrangements are ingeniously contrived, and it may be justly termed a self-acting machine, for when once set in motion, no other aid than the power which drives it is requisite to its cutting a whole series of boards, of uniform dimensions, all round the log, having their thin-edged sides attached to the centre-piece. These boards being removed, a second series of boards may be cut in like manner to the former, provided the log is big enough.

"This machine," Mr. Eastman says, "furnishes a new method of manufacturing lumber for various useful purposes. Though the circular saw had previously been in operation in this country, and in Europe, for cutting small stuff, it had not, with the knowledge of the writer, been successfully applied to solids of great depth; to effect which, the use of section-teeth are almost indispensable.

"In my first attempts to employ the circular saw, for the purpose of manufacturing clap boards, I used one nearly full of teeth, for cutting five or six in depth, into fine logs. The operation required a degree of power almost impossible to be obtained with the use of a band; the heat caused the plate to expand, and the saw to warp, or, as it is termed, 'get out of true.' To obviate these difficulties, I had recourse to the use of section-teeth, and the improvement completely succeeded. The power required to perform a given quantity of work by the former method, was by this diminished at least three quarters. The work, formerly performed by seventy or eighty teeth, was, by the last method, performed by eight teeth; the saw-dust, which before had been reduced to the fineness of meal, was coarser, but the surface of the lumber much smoother than when cut with the full-teethed saw. The teeth are made in the

form of a hawk's bill, and cut the log up, or from the circumference to the centre. The saw may be carried by an eight-inch band, and when driven a proper speed (which is from ten to twelve hundred times per minute) will cut nine or ten inches in depth into the hardest white oak timber with the greatest ease. The sappers, at the same time, cut off from one to two inches of the sap, and straighten the thick edges of the lumber.

"The facility with which this saw will cut into such hard materials, may be supposed to result from the well-established principle, that where two substances in motion come in contact, their respective action on each other is in direct proportion to their respective velocities; thus, a circular plate of iron put into a quick rotary motion, will, with great ease, penetrate hardened steel, or cut through a file when applied to its circumference; and the same principle is applicable to a saw for cutting wood. The requisite degree of velocity is obtained by the continuous motion of the circular saw, by which also it has greatly the advantage of one that has but a slow motion, on account of dulling; as the teeth are but little affected, and being only eight in number, but a few moments' labour is required to sharpen them. If the velocity of the saw were slackened to a speed of but forty or fifty per minute, it would require at least four such bands to carry it through a log as above described.

One machine will cut from eighteen to twenty hundred of square feet of pine timber per day, and two of them may be driven by a common tub-wheel, seven or eight feet in diameter, having six or seven feet head of water, with a cog-wheel and trundle-head, so highly geared as to give a quick motion to the drums, which should be about four feet in diameter. The machine is so constructed, as to manufacture lumber from four to ten feet in length, and from two to ten inches in width, and of any thickness. It has been introduced into most of the New England states, and has given perfect satisfaction. The superiority of the lumber has, for three years past, been sufficiently proved in this town, (Brunswick Maine,) where there have been annually erected from fifteen to twenty wooden buildings, and for covering the walls of which this kind has been almost universally used. The principal cause of its superiority to mill-sawed lumber, is in the manner in which it is manufactured, viz., in being cut towards the centre of the log, like the radii of a circle; this leaves the lumber feather-edged in the exact shape in which it should be, to set close on a building, and is the only way of the grain in which weather-boards of any kind can be manufactured to withstand the influence of the weather, without shrinking, swelling, or warping off the building. Staves, and heading also, must be rived the same way of the grain, in order to pass inspection. The mill-sawed lumber, which, I believe, is now universally used in the middle and southern states, and in the West Indies, for covering the walls of wooden buildings, is partly cut in a wrong direction of the grain, which is the cause of its cracking and warping off, and of the early decay of the buildings, by the admission of moisture. That such is the operation, may be inferred, by examining a stick of timber, which has been exposed to the weather; the cracks caused by its shrinking all tend towards the heart or centre, which proves that the shrinking is directly the other way of the grain. It follows, that lumber, cut through or across the cracks, would not stand the weather in a sound state, in any degree to be compared with that which is cut in the same direction with them. I have no hesitation in stating that one-half the quantity of lumber manufactured in this way, will cover, and keep tight and sound, the same number of buildings for a hundred years, that is now used and consumed in fifty years. Add to this, the reduction of expense in transportation, and of labour in putting it on, and I think every one must be convinced that the lumber manufactured in this improved way is entitled to the preference.

"In manufacturing staves and heading, a great saving is made in the timber, particularly as to heading, of which at least double the quantity may be obtained by this mode of sawing to what can be procured in the old method of riving it; nor is the straight grained or good rift indispensable for the saw, as it is for the purpose of being rived. The heading, when sawed, is in the form it should be, before it is rounded and dowed together, all the dressing required being



merely to smooth off the outsides with a plane. Timber for staves ought to be straight, in order to truss, but may be manufactured so exact in size, as to require but little labour to fit them for setting up. Both articles are much lighter for transportation, being nearly divested of superfluous timber, and may be cut to any thickness required, for either pipes, hogsheads, or flour barrels."

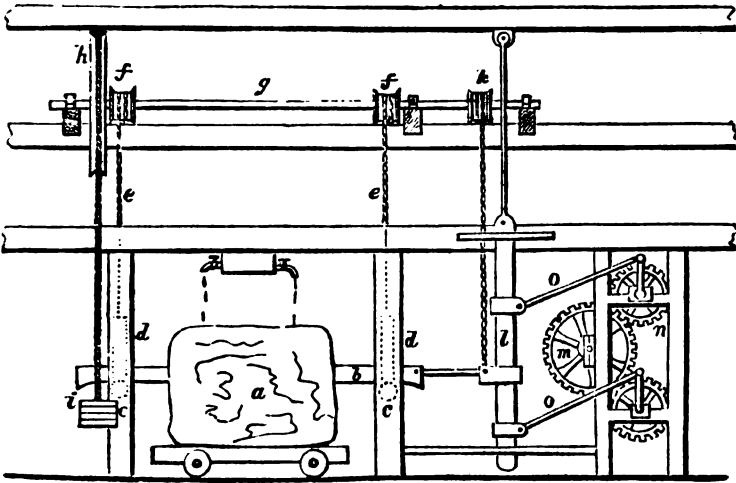
Mr. Alexander Craig, of St. Bernard's, in the county of Mid-Lothian, obtained a patent, in 1831, for "certain improvements in machines or machinery for cutting timber into veneers or other useful forms." In one of these improvements, Mr. Craig employs a circular saw, which he makes to traverse the whole length of the veneer to be cut, while it revolves on its axis in the usual way. It is made to traverse by means of a crank, having a radius equal to half the length of the intended veneer, and a connecting-rod, of length sufficient to prevent too much obliquity of action. A uniform tension is preserved on the band which communicates motion to the saw while it approaches to, and recedes from, the source of motion, by carrying the band round a pulley stationed at a small distance beyond the greatest distance of the saw from its driving drum. Though we have mentioned but one saw, there are a series of them attached to the same frame, and put in motion by the same band, which is pressed down by an adjusting pulley between each pair of saws, that it may turn them with more certainty, by embracing a larger portion of the circumference of the riggers fixed on their axes. The log of wood from which the veneer is to be cut is suspended between centres, similar to those of a turning-lathe, and made to rotate in contact with the saws, so that it may be cut into one continuous spiral veneer. It is evident, that to produce a uniform motion in that part of the log in contact with the saws, is necessary to its perfect action; and this the patentee has effected in a very ingenious manner: he puts into slow motion, by a species of gearing known by the name of the endless screw, a shaft, having on its extremity a metallic cylinder, with a surface roughed in a manner similar to the surface of a rasp; and this cylinder, being pressed against the circumference of the log, will cause it to revolve at the same speed, whatever be its diameter. The specification is concluded by a description of an arrangement by which the saws are made to cut beyond their centres in a stationary log. This is effected by attaching them on axes which do not project beyond the surfaces next the log. To the frame carrying these saws, a descending as well as an alternating motion is given; and the veneer being, by a guide-plate, made to fold back under the saws, it is clear that they will with facility cut to any required depth, without reference to their diameters. See the article **VENEER**.

The sawing of stone, as our readers cannot fail to have noticed, is an extremely slow operation, and no improvement of importance has been effected in the process for many centuries; the ancient mode of causing a plate of iron stretched out in a frame, to reciprocate horizontally by the two hands of the sawyer, seated before it, is still generally practised. In dividing very soft stone, the saw itself acts with efficacy upon the stone, by means of its small rude teeth, or notches, which the sawyer makes in its edge by striking it with a coarse tool: but the chief utility of these notches is to collect and apply the particles of sharp sand that are carried by a small current of water down into the incision, and under the saw. In hard stone, almost the whole effect of cutting is produced by the attrition of the sand, aided by the pressure of the weight of the saw.

In 1825, a patent was taken out by Mr. James Tullock, for "improved machinery for sawing stone," in which, however, the same principle of cutting is still adhered to; but the general arrangements of his stone-sawing-mill are judicious for the application of *power*; we therefore annex a description, with an illustrative cut.

A block of stone is shown at *a*, supposed to be under the operation of a number of saws *b*, fixed parallel to each other in a frame. The ends of this frame are formed on the under side into inclined planes, which run upon two anti-friction rollers at *c c*; so that when motion is given to the saws, each end of the frame will be alternately lifted up, and allow the sand and water (supplied

by a small cistern represented) to descend into the fissure. The anti-friction rollers are attached to two slides, placed in grooves, in the two upright posts *d d*, and are suspended by two chairs *e e*, wound round the barrels *f f*, on the



shaft *g* : this shaft turns in the bearings shown, and carries a third barrel *k* and a large pulley *h* ; to the latter is suspended a weight which partly counterbalances the weight of the saws and frame ; and a chain, passing round the barrel *k*, is attached at the other end to a sliding piece, on a vibrating beam *l*. The gear represented on the right hand of the engraving is for giving motion to the saw-frame. The power of a first mover being applied to the toothed wheel *m*, it actuates the two smaller wheels *n n*, to the shafts of which are fixed cranks, which as they revolve give motion, by means of the connecting-rods *o o*, to the vibrating beam *l*, and the latter gives the alternating motion to the saw-frame *b*. The several pulleys to which the frame is suspended admit of its regular descent, and with a uniform pressure. The weight of the saws should of course always predominate over the counterbalance, that they may act effectively upon the stone.

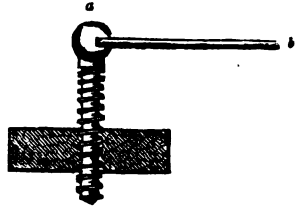
It appears from the specification, that the patentee applies this mechanism in the forming of grooves, mouldings, cornices, pilasters, &c., of marble and other stone, by means of properly-indented instruments, which are to traverse the face of the stone, suspended in a suitable frame. By suspending the saws or tools in the manner described, it is considered that a great advantage is gained, as they may thereby be kept in a perfectly horizontal line, so that the face of the stone may be acted upon uniformly in all its parts, and the hardest parts be reduced equally with the softest.

**SCALE.** A mathematical instrument, consisting of various lines drawn on wood, ivory, brass, &c., and variously divided, according to the purposes it is intended to serve ; whence it acquires various denominations, as the plain scale, diagonal scale, plotting scale, Gunter's scale, &c. Scales of equal parts, marked upon plans, drawings, &c., are explanatory of the real dimensions of the objects delineated, instead of their actual dimensions on the paper.

**SCALES.** A term commonly applied to the ordinary balance or weighing machine, which see. The term scales, however, is often applied to the boards or dishes only, in which the goods and the weights are placed.

**SCALES OF FISH** consist of alternate layers of membrane and phosphate of lime ; they are employed in the arts in the fabrication of artificial pearls. See **PEARLS**.

**SCREW.** The screw is one of the most powerful and useful of the simple machines or mechanic powers. It is a modification of the inclined plane, as will easily appear to any one who reflects a little on its construction. If a triangular piece of paper be rolled round a cylinder, it will form a spiral inclined line round it, which will be not an inapt representation of the nature of the screw. The screw with the projecting thread moves within a concave spiral groove cut in the interior of a hollow cylinder, which is termed the female screw or nut. The screw is generally turned by means of a lever, as represented in the annexed cut at  $a b$ ; and the power obtained by the instrument is calculated by dividing the circumference of the circle described by  $a b$  by the distance between two successive threads of the screw. Thus, if the lever  $a b$  be thirty inches long, and the distance between two threads of the screw be half an inch, the circumference described will be 94 inches;



which, divided by half an inch, gives 118 as the increase of power obtained by this machine. In this case, a man who could exert a force of 100lbs. would be enabled to produce a pressure equal to that of 18,800 lbs. From these remarks it will be seen that there are two ways of increasing the power of this machine; viz. by lengthening the lever  $a b$ , or by diminishing the distance between the threads. The former would be limited by the unwieldiness thereby given to the machine; and the latter, by the circumstance that the threads become weaker in proportion as they are diminished, and hence a slight resistance would tear them from the cylinder. These inconveniences are obviated in a contrivance of Mr. Hunter's, in which the required strength and compactness may be carried to any extent. This contrivance consists in the use of two screws, the threads of which may have any given strength, but which differ slightly in breadth. While the working point is urged forward by that screw whose threads have the greater breadth, it is drawn back by that whose threads have the less; so that, during each revolution of the screw, instead of being advanced through a space equal to the breadth of either of the threads, it moves through a space equal to their difference. The power of such a screw will be equal to that of a single screw, the distance between whose threads is equal to the difference of the distances between the threads just mentioned.

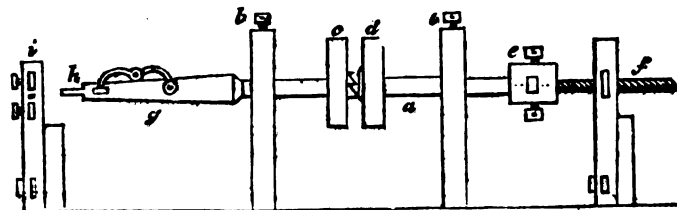
The great power and compactness of the screw, as a mechanical engine, render it highly useful in the formation of presses, in which a great pressure is required. The screw is therefore usually employed in the expression of juices from solid bodies, in coining, and in reducing the bulk of light and soft bodies, so as to render them convenient for exportation. (See PRESS.)

The screw is also used very efficiently in the measurement of very minute motions and spaces. Thus, suppose the screw to have one hundred threads in the length of an inch, each revolution of the screw will advance the point one hundredth of an inch. Now, if the head of the screw be a circle one inch in diameter, the circumference of the head will be somewhat more than three inches; this may be easily divided into a hundred equal parts, each distinctly visible. If a fixed index be used, the hundredth part of the revolution of the screw may be observed, and this will advance the point of the screw one ten-thousandth of an inch. To observe the motion of the point of the screw, a fine wire is attached to it, which is carried across the field of view of a powerful microscope, by which its motion is made distinctly perceptible. Such a screw is called a micrometer screw, and is much used in graduated instruments, for astronomical observations. Hunter's screw may be also conveniently used for the same purpose.

The most common kind of screws are those used by carpenters and other mechanics, for fastening wood, or wood and metal together, and are therefore

usually termed in this country *wood-screws*, though the Scotch name of *screw-nails* is somewhat more appropriate, as distinguishing them from other kinds of screws.

The blanks for wood-screws are forged by the same class of workmen as make nails; they in fact closely resemble the counter-sunk clout nails, with the exception of their ends not being pointed. An improvement upon this method has been adopted by some screw manufacturers, which consists in making the blanks out of round rolled iron, cut into the requisite lengths, and then pinching these pieces, when red hot, between a pair of clams or dies, in the chaps of a vice, and forming the heads by a hammer, or the stamp of a fly-press. To form the threads, files were used in the infancy of screw-making, but this process has been long superseded by the modern practice of cutting and tapping. The forged blanks being well annealed, their small ends are successively placed into a jointed chuck, at the end of a steel mandril, where they are gripped fast and made to revolve, while a file is held against them, to brighten their stems and the countersinks of their heads. The blanks are then released, their heads filed flat, and the nick for the screw-driver made by a circular saw. The blanks are now ready for tapping, by a small apparatus similar to the common lathe, as represented in the following cut. At *a* is a steel cylindrical mandril, about



twelve inches long, revolving in collars in the puppets *b b* by the motion of a strap passing round the pulley *e*; *d* is a loose pulley to carry the strap when taken off *e*. At *e* is an iron box made to open and firmly fix by screws the end of the regulating-screw *f*, of which there are as many provided as there are varieties in the threads of the screws to be cut; they are usually five or six inches long; *g* is the chuck in which the screw is fixed, by means of a kind of hasp or shackle bolt, with its end projecting as seen at *h*; whence it is projected by the revolution of the regulating screw, between a pair of cutters or dies at *i*, of the same degree of fineness as the regulator screw used. The shape of the thread or worm itself depends, however, upon the form of the operating edges of the cutters.

The patent screws manufactured by Mr. Nettlefold, of Holborn, are made with great attention to the perfection of the worms; the upper side, as intended to be represented in the following *Fig. 1*, is very flat, or inclined but very little from a plane, passing through its diameter, which causes a great resistance to its being forcibly pulled out of the wood; and the under side of the worm is considerably inclined, which greatly facilitates its entrance into the wood, rendering it unnecessary, in soft elastic woods, to bore any hole for its reception; the form is best seen in the sectional representation of a portion of the screw in *Fig. 2*, the black space being the screw, and the tinted parts on either side, a portion of the wood; also exhibiting the facility of entrance, and the difficulty of drawing out. The greater part of the common wood screws sold in the shops, are, however, very wretchedly constructed, in this as well as other respects. *Fig. 3* shows a section of their shallow, rough, and imperfect worms, the heads, stems and nicks in which are fit accompaniments to articles so fabricated. The chief defects of common wood screws, besides bad threads, are the having, at the termination of the worm, a projecting burr, which is apt to

tear away the wood before it, and leave little or no solid matter for the screw to hold by; the nicks in the heads being too shallow, or highest in the middle, preventing the screw-driver from taking an efficient hold to turn them in and



Fig. 1.

out. These defects are carefully obviated in Mr. Nettlefold's screws, and they are made with extraordinary truth and beauty, notwithstanding the very low prices at which they are manufactured.

The machinery by which wood screws are made vary considerably in the different manufactories, and numerous patents have been successively taken out for improved processes; in several of which, attempts have been made, with partial success, to fabricate them without the intervention of human hands, farther than furnishing the raw material to the machines. Several persons have succeeded in *casting* screws,—an operation of a very curious, and, apparently, difficult nature. A Staffordshire manufacturer of the name of Manlin, had a patent for an ingenious process of this kind, which is described in the 13th volume of the *Repertory of Arts*.

Immense quantities of screws, of the smaller kind, are made from wire, in the neighbourhood of Birmingham and Wolverhampton. They are chiefly made in the houses or cottages of the workpeople, wherein the children materially assist; the screwing being effected by turning a winch handle fixed to the end of a cylindrical mandril, the other end of which is furnished with a chuck to contain the screw blank, which is thrust forward and turned round between steel dies fixed in a puppet head, the action being regulated by a screw thread on the mandril, taking into a hollow screw fixed in an intermediate puppet head.

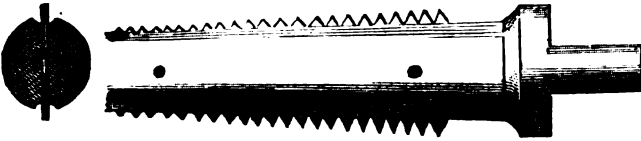
In the 41st volume of the *Transactions of the Society of Arts*, is described a very convenient and simple tap (invented by Mr. Siebe, of the Strand) for cutting hollow screws in wood, by which workmen are enabled with the same tool to form either right or left, single, double, or treble hollow screws of the same diameter. The screws capable of being made by this implement, are, however, far from being mathematically accurate, but will be found to be quite as good as the hollow screws made in the usual way, and adapted to the use of various wooden articles of domestic furniture, and to some common kinds of machinery.

The tap is a thin quadrilateral piece of steel, of the length and breadth of the required screw, having its longitudinal edges cut into saw teeth; the teeth in one row being opposite to the intervals in the other, and therefore representing a section of a screw, the teeth being sections of the threads. A cylinder of hard wood is turned, so as to correspond with the dimensions of the intended screw, and a longitudinal piece being sawn out from the middle, representing a section through the axis, the serrated plate is to be inserted and firmly rivetted in its place. The cylinder terminates in a flat head, for the purpose of receiving a key or lever, which enables the workman to overcome the friction experienced in cutting the screw.

In order to use this tool, a cylindrical hole, equal in diameter to the cylindrical stem, is to be bored in a piece of wood, and the serrated cylinder being

then introduced, giving it a circular or spiral motion, will form a right or left-handed screw, according to the direction in which it is turned; and by entering two or three threads at once with a common V tool, the same tap will give a double or treble-threaded screw.

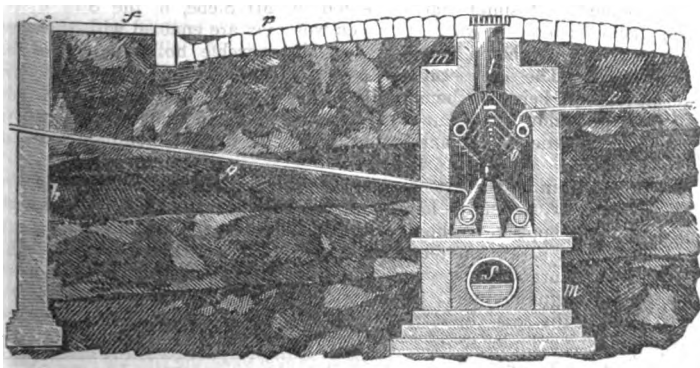
The hard wood being first made into a screw, the blade is rivetted in, and the teeth are made by a file to fit the wooden threads; the blade is then removed, the threads in the wooden cylinder are turned off, leaving it smooth; the blade is then tapered at the point, so that the first teeth are no bigger than the cylinder; it is then rivetted again in its place, and the instrument is complete, as represented in the subjoined *Fig. 1.* *Fig. 2* is an end view of the same, which is exhibited to show that the cylinder is cut away a little where the teeth

*Fig. 2.**Fig. 1.*

are inserted, to make room for the shavings. As the cylinder fits the hole, and the blade is taper, a gradual and steady cut is secured, which may either be to the right or left hand.

Mr. Siebe also proposes steel taps for metal screws to be made in the same manner, by filing away a solid screw of metal, so as to present two cutting edges, similar to those attached to the wooden cylinder.

**SEWER.** A subterranean channel or canal, formed in towns and other places, for draining and purifying them. They are made of such materials and forms as suit the circumstances of the locality, and come too often under the observation of the public to need our explanation. But in connexion with this subject we may mention the scheme of *Subways*, proposed by Mr. John Williams, of Cornhill, for which he took out a patent in 1822, and strove arduously to get adopted in the city of London. The title of the patent explains its object, viz., "a method to prevent the frequent removal of the pavement and carriage paths for laying down and taking up pipes, and for other purposes, in streets, roads, and public highways."



The nature of Mr. Williams's plan will be fully understood on inspection of the annexed drawing, representing a transverse section of the street.

$r r$  represents the paved road-way;  $f$ , the foot-pavement;  $b$ , a section of the front wall of the basement story of a house, with a pipe  $p$  to supply water from one of the mains  $o$ , contained in the sub-way. The opposite side of the diagram is incomplete, having been cut off for want of room; the pipe  $p$  there shown is for the supply of the house on that side, with either gas or water; the upper pipes, which may be supposed to belong to different companies, are suspended to the crown of the arch by iron straps. The lower pipes are supported upon the floor;  $m m$  shows the outline of the masonry;  $s$ , the common sewer, which has, at stated distances, openings into the sub-ways, but secured by air-tight doors, to prevent the escape of effluvia;  $h$ , one of the holes covered with a grating, for the admission of light and the circulation of air. The patentee proposes to build his "sub-ways," (as he terms them) when practicable, over the sewers, with drainage from them into the sewers; the dimensions are about 7 feet high and 4 feet wide, but these may be varied according to circumstances. Openings are to be made on the tops of the sub-ways, or tunnel, at every hundred feet, for the purpose of admitting air and light; and passages are to be made in the sides, to admit inspectors and workmen. Along each side of these tunnels are to be arranged pipes, to supply the inhabitants of the streets under which they are built with water and gas.

Amongst the advantages enumerated by the patentee to be derived from the introduction of sub-ways, may be noticed the facility with which a line of pipes may be deposited along a street, without breaking up the pavement, and the consequent annoyance to the inhabitants, obstruction to the passengers, and detriment to the stability of the roads; the immediate access at all times to inspect the pipes, effect the requisite repairs, or obtain an additional supply of water in cases of fire, and better opportunities of repairing and clearing the common sewer, whether it be situated underneath or alongside of the sub-way.

SHEATHING, in *Naval Architecture*, a sort of covering nailed all over the outside of a ship's bottom, to protect the planks from the ravages of worms. Formerly, this sheathing consisted only of boards tarred and payed over; but now copper is resorted to, not merely as a substitute, but as an additional covering, and it has become almost universal, where the expense can be sustained; it is of especial utility in vessels making long voyages and into warm climates. The rapid corrosion of copper, by the action of sea water, renders the frequent renewal of it a very serious item of expense to the ship-owner. In a patent which Mr. Robert Mushet took out a few years ago, "for certain means or processes for improving the quality of copper and alloyed copper, so as to render it more durable when employed as sheathing to ships bottoms," he states, that, owing to some defect in the manufacture of the copper, the sheathing upon a ship is sometimes worn away by oxidation in a much shorter period than usual. The cause of this Mr. Mushet considers to arise not simply from the impurity of the metal, but from the undue proportion of the alloy with which it may be mixed. He also states, that he has found that the purest copper, exposed to the action of sea-water, is not so tenacious as when alloyed in the manner he proposes in his specification, and on which he founds his patent. He directs, that to 100lbs. of copper is to be added 2 oz. of the regulus of zinc, or 4 oz. of the regulus of antimony, or 8 oz. of the regulus of arsenic, or 2 oz. of grain tin. Instead of these alloys separately, they may be employed in conjunction in the following proportions: viz. to 100lbs. of the copper add half an ounce each of the zinc and tin, 1 oz. of the antimony, and 2 oz. of the arsenic.

Mr. Christopher Pope, of Bristol, took out a patent, in 1824, for the manufacture of metallic sheathing in which copper is altogether discarded. These plates are composed of tin and zinc, or of tin, lead, and zinc. Mr. Pope says, in his specification,—“To unite tin and zinc, I take a certain quantity of zinc, and melt it in an iron pot, and when melted, I add an equal quantity of tin; and having stirred them together in a fluid state, I cast cakes of it in moulds of about 8 inches broad, 10 inches long, and  $\frac{1}{4}$  of an inch thick, which cakes are afterwards hammered or rolled out into sheathing. . . . . To unite tin, lead, and zinc, I melt a certain quantity of lead, and add to it twice the quantity of

tin. This composition I cast into small lumps, and having melted three times as much zinc as I had previously melted of lead, I then add the small lumps of tin and lead, and melt the whole together; which method I find to be the best." This mixture he casts into cakes of the size before mentioned, and then rolls them into sheets; and he particularly enjoins, that no more heat be used than is just sufficient to compound the alloy, as the metal becomes hardened by an excess of heat; and that it is advisable, in rolling out the cakes, to heat them to the temperature of boiling water, by which he says that "they will roll or hammer softer than when cold." This metallic sheathing has, we are informed, been more extensively employed for covering of the tops of houses, than the bottoms of ships.

A few years ago, some very favourable accounts were published of the patent Indian rubber sheathing, consisting of a coarse fabric of fibrous material, saturated with a solution of the elastic resin, together with pitch and tar. The price of the sheathing was ten pence per sheet, of the size of 34 inches by 20. It was found to be a complete protection against the worm, and must, at the least, we think, form an improved substitute for the felt in general use.

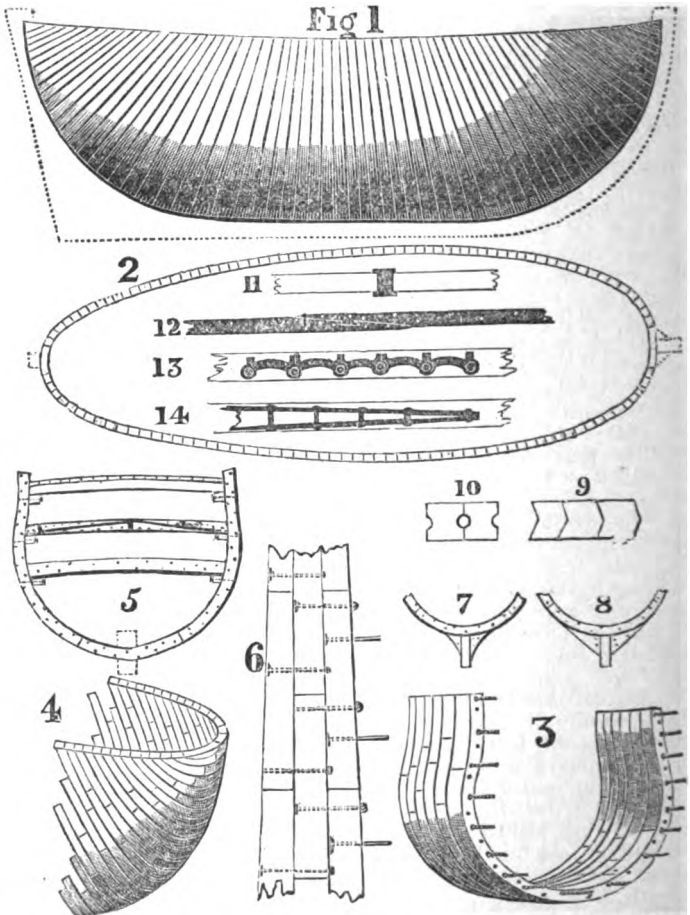
It was for some time supposed that Sir H. Davy had discovered a remedy against the rapid oxidation of the copper. Regarding the action of the sea-water upon copper as of a galvanic nature, that great chemist considered that, by the addition of small pieces of tin and zinc, the copper would be rendered negatively electrical, and oxidation prevented. Ships were sheathed on this principle, and sent to sea; but they proved such bad sailers, from the foulness of their bottoms, that a negative was soon put upon the scheme. It is true that the copper was thus protected by the zinc and tin, but the barnacles (shell-fish) attached themselves so much to the protectors, as to introduce a greater evil than they were calculated to remedy. Sanguine hopes were entertained of the success of this plan, and the disappointment consequent upon failure was, of course, extensively felt. Founded upon the same theory of the galvanic influence, a patent was, a few years ago, obtained by Professor Pattison, for making use of iron plates, protected by zinc, which, it was asserted, entirely prevented the oxidation of the iron: and that a ship sheathed with iron and little bits of zinc had been two years at sea, and returned home with a clean and bright surface. The specification of the patent states that the iron plates may be of the usual dimensions of the copper plates, and for each area of 100 inches in the iron, a plate of zinc of from one eighth to one fourth of an inch thick, equal to five inches in area, is attached to the lower extremity of the sheet, so that in sheathing the vessel from the upper part downwards, each succeeding sheet of iron shall be in contact, by lapping over, with the zinc plate of the sheet immediately above it. Plates of zinc must also be attached to the inside of the sheet of iron, bearing a proportion in area to those on the outside, of 3 to 5. The spikes and bolts by which the sheathing is fastened to the vessel are each to be furnished with a disc, or washer, of zinc, fitting closely to the head; and it is recommended that they be driven well home, to insure perfect contact. The nails employed are to be made concave under the head, and the cavity is to be filled with melted zinc. The proportion of five square inches of zinc to one hundred of the iron, is not insisted on; any greater proportion will be equally effectual, and the zinc may be alloyed with copper, tin, or lead, in the proportion of from 3 to 10 per cent. By this mode of sheathing vessels, it is asserted, in the specification, that the corrosion or oxidation of the metal will be nearly, if not entirely, prevented.

**SHIP.** The general name for any large vessel fitted with one or more masts and sails, for the purpose of navigating on the sea. The name ship is, however, more strictly and properly applied to a vessel with three masts and a bowsprit; each mast consisting at least of two, and most frequently of three component parts; namely, lower-mast, top-mast, and top-gallant-mast, each of them having its corresponding yard carrying a square-sail rigged aloft, the bowsprit also being fixed, and furnished with sprit-sail-yard, jib-boom, &c. The distinguishing features of sea-going vessels of other descriptions are noticed under their respective heads; and as it will not accord with the



prescribed limits of this work to enter at large into the subject of naval architecture, we shall in this place introduce to the attention of the reader some interesting improvements and suggestions, which have recently been made by ingenious and scientific men.

A few years since, Mr. David Redmund, an engineer of the City-road, London, (who was originally a shipwright,) took out a patent for improvements in the mode of constructing the hulls of ships and other vessels, the main objects of which were the obtaining of a more effectual security against shipwreck, and facilitating the general adoption of steam navigation. The



annexed description, together with the observations upon it, we extract from the specification of the ingenious patentee.

"The present mode of framing the hulls of vessels leaves a vacancy between the ribs and frames, which said ribs or frames are not firmly connected together, so as to unite their strength, until the planking is affixed to them; so that, previous to planking, the hull has no strength whatever. Now as this is, I conceive, the foundation of the structure, I respectfully submit that, when in that state ready for planking, the vessel should be, if possible, of

sufficient strength to resist all such shocks or concussions as vessels are liable to meet with; so that when planked, she should acquire the full portion of additional strength which can be imparted to her construction by that process, and that the shocks or concussions to which all vessels are liable, should not be received on, or affect, the tree-nails, or bolts, which secure the planking to the frame of the vessel. Now, as the present vessels, previous to planking are not, by their constructions, capable of supporting themselves, and only acquire strength by their planking being secured to the frame or timbers, by wooden tree-nails or bolts, I presume it is evident that the greatest portion of every violent strain, shock, or concussion that the vessel is subject to, must, in a great measure, be received and sustained, in some direction or other, by the aforesaid wooden tree-nails or bolts, which have first given strength to the fabric by securing the frames and planking together. The ribs or timbers not being united close together, there seems to be nothing to prevent the greatest portion of the shocks being received by the tree-nails or bolts; the repetition of the shocks soon works the tree-nails loose in their holes, and the vessels then become crazy and leaky; which shows clearly how very inadequate they must be for the purpose of sustaining any lengthened continuation of such strains and concussions as all vessels are liable to. In my construction of vessels I have no vacancy between my ribs or timbers; but I begin at the middle of the ship, and bolt each rib or frame firmly to its fellow, inserting the bolts in each that are to receive the next, as shown in *Fig. 3*, which shows six of the first ribs connected together, with the heading joints always crossed, and the bolts standing out to receive the next rib; so I work right and left to the head and stern, as shown in *Fig. 1*, which is a longitudinal section of all the ribs or timbers, showing the bolts let in at the heads to admit of each rib being bolted close to its fellow, each requiring to have holes made in them, to receive the nut of the bolts of the previous one, as is seen in *Fig. 1*. My heading joints are each grooved a little way in, and a tongue or tenon of metal driven in after it is in its place, which will serve as a stop to the caulking, and give steadiness to the ends; and the tongue or tenon should enter about an inch or more into the ribs on each side. It will be requisite to have as large washers or plates under the heads of the bolts, and also under the nuts, as the size of the timbers will admit of, only the edge of the plates should not come within three quarters or half an inch of the face of the timbers; so that, when caulked inside and out, both bolts and plates are secured from air and water. The holes for the bolts should be about one-fourth of the thickness, or a little more, from each edge; so that, if the timber were eight inches, the centre of the hole should be about two inches and a quarter, or two inches and a half from each edge. It may be found proper in some light constructed vessels to have the bolts in the centre of the timbers; in such cases the vessels will be exceedingly strong, but will not be so stiff as the other way. It will be seen by *Fig. 1*, that all my timbers are made smaller at the upper end, and larger at the lower part next the keel; and, as every good practical ship-builder is acquainted with the prevailing methods of striking out the timbers to stand at any angle or inclination, I need only remark, that the angle of inclination at which I have shown the timbers, appears to me to be the best. But if the test of experience should suggest any alteration, it is easily done by making the timbers more or less of the wedge form, as may be found best.

"The section No. 1 also shows the timbers are of various dimensions, as it is not absolutely necessary they should be all of one size, only they should be tapered in proportion, so as to keep the proper angle; but they should be all of the same dimensions the other way, so as to produce an even surface for the planking, as at present; and I should always keep my timbers to their fullest dimensions from outside to inside, as the more I increase the surface of my abutments, the greater the stability of the vessel,—always bearing in mind that I am constructing an arch, to be self-abutted in every direction. I can reduce the thickness of the planking, and increase the thickness of the timbers, and, by so doing, greatly increase the strength of the vessel; and as strength and stability are the principal objects I propose to obtain by my im-

provements, in those parts of the vessel at or near the head or stern, where the ribs form a sharper or more acute angle at the keel, as shown by *Figs. 7* and *8*, I would keep the line of the timbers more to the circle, to admit of the timbers which cross the keel being cut out of trees of moderate dimensions, without the grain running too much across, and to fill out the shape with what is technically termed dead wood or chocks, as shown by *Figs. 7* and *8*, which should be secured to the rib, and bolted to its fellow piece; which, by increasing the surface of the abutments, adds stability to the arch, and proportionate strength to the vessel.

“ If any objection should be made about the quantity of dead wood or chocks accumulating, by adhering strictly to the rule laid down as relative to *Figs. 7* and *8*, I would wish it to be understood, that if the ribs were prepared for those parts as they are at present, only to diminish them from the top to the bottom, as before stated, and bolt them firmly together, and to the keel, as at present, the vessel would be infinitely stronger than by the ordinary mode, but would not, in my opinion, be of equal strength and durability as if executed agreeably to the rule laid down in *Figs. 7* and *8*; as, on my plan, if the whole of the keel, stern-post, and the dead wood, were all carried away, the frame of the vessel would remain firm and secure, and would only have lost the trifling portion of strength she had acquired from her keel and dead wood being affixed to her frame. It may be proper here to remark, that on my improved mode of ship-building, every additional piece of timber affixed to it from the first rib or frame to the last plank, all and every additional piece so affixed brings with it its proportionate addition of strength and stability to the vessel, beyond its own weight. Even what is technically termed dead wood, on my principle, brings its proportionate addition of strength and stability to the vessel, if it is put on, and secured to each rib, and bolted to its fellow as directed.

“ The beams on which the decks lay should be secured to the sides of the vessel in the usual manner; but as room is considered a great object between decks, and the present decks, beams, and planking take up from 10 and 11 to 14, 16, and 18 inches, according to the size of the vessel, and the number of decks, &c., I propose cutting oak scantling to the size or thickness of the decks,—say about 6 or 8 inches square, according to the width of the vessel,—keeping the curve of the deck as much as possible,—say about 7 or 8 inches in the width, of about 28 or 30 feet, and the scantling about 6 or 8 inches, taking about the same quantity of timber as at present used in beams and planking. These I bolt firmly together (see *Fig. 5*.) after the same manner as the ribs of the hulls, with about three-quarter or seven-eight bolts, according to the rate or tonnage of the vessel. The scantling should be all the length across the vessel, and being bolted together as above, would be found of great strength; but to increase the strength as might be required, I would truss two together at about 6 or 8 feet apart, as in middle-deck *Fig. 5*; or a truss, constructed as *Fig. 14*, might be inserted into each scantling; or a rule joint self-abutted chain, as *Fig. 13*, might be let into the edge of the scantling, for the same purpose: and they should continue through the sides of the vessel, having a stout nut-screw and plate, to enable them to secure the sides firmly to the deck,—thus answering a double purpose; and by having fewer or more of them, the decks may be made of any additional strength required, with an even surface underneath, yet will not take up half the space occupied by the present decks. I merely name these methods, if additional strength should be required; but it is my opinion there will be sufficient strength without them. In vessels where expenses or first cost were not an object, the timbers might be prepared with a circular groove in the centre, (see *Fig. 10*.) in which groove a strongly twisted rope of oakum might be put, which, being left rather large, would, when screwed up tight, form a strong and tough tongue or key, and also a stop for the caulking. The decks, if required, could be done in the same way, and they might be caulked on both sides, if requisite, and if any objection should arise about the joints of the decks running across the ship, they might board it the other way with thin boards (as see *Fig. 5*), or the scantlings might run from head to stern, kept to the curve, and bolted together the same as the others; in which case it would

form an arch, the abutments of which were secured, but would not be so strong as the other way. *Fig. 4* shows how the timbers come to a finish at the head and circular stern of the vessel. The keel or stern-post is not shown, as it is only to show how the timbers finish, and also what very short pieces may be occasionally used; as the strength of the arch does not so much depend on the length of the pieces, as on the increased surface and effectual security of the abutments. It will be understood that spaces for port holes in ships of war can be left without materially diminishing the strength of the vessel.

"It is supposed in this description, that the keel is first laid down, as usually done, only its internal edge will be formed to the curve of the under part of the hull, exclusive of the filling out pieces or chocks alluded to in *Figs. 7* and *8*. My improved ship now having her decks in and firmly secured to the beams on which they rest, and also to the sides, head, and stern of the vessel, after the methods before described, I now proceed to caulk all her joints, inside and out, and her decks also; which being done, she then presents the novel sight of a ship of great strength, previous to planking; presenting, in every assailable direction, the strength and resistance of an arch, self-supported and self-abutted in every direction,—no bolt or pin, but those which secure the decks to the frame, being visible throughout her whole frame, to convey to the beholder the slightest idea of the mode by which her abutments are secured; and her frame so firmly united together, her invisible endless chains of bolts being perfectly secured from air and water by the caulking inside and out, the vessel itself being, of course, water-tight every where, and of incredible strength, as the force of every shock is received on and divided amongst her numerous abutments. In this state, previous to planking, let the comparison be drawn between my improved ship, and one of the present day, previous to their being planked—one of great strength, the other of no strength at all—not being capable of supporting itself until planked. I would now remark, that as the process of planking imparts such a great degree of strength to all modern-built vessels, it will, of course, appear to any person, that my vessel must derive a considerable additional increase of strength and stability by that process, as the tree-nails which secure the planks to the frame cannot be disturbed by any shocks or strains the vessel may receive, the force of all outward shocks being received on and divided among her numerous abutments—and of all strains from weight or cargo, on her abutments and bolts, which must be drawn apart before the tree-nails can be affected, which cannot occur if they are in proportion to the tonnage of the vessel. I now plank her; and of course my vessel would admit of a considerable reduction in the thickness of the planks of ships of war, which may be added to the timbers,—how much, I must leave to the discretion of the builders, who will act according to circumstances.

"The planking would be fastened, as usual, with tree-nails, as I know nothing better; and as the force of any shock will not now be felt by them, but received on the abutments, they, of course, will now be fully effective. Each alternate rib should be bolted to the keel, and the keelson bolted through each of the others, and through the keel also. The thickness of the bolts will be regulated by the weight and tonnage of the vessel. A vessel of 500 tons should have the six upper bolts within six or eight feet of the top, in the first sixteen or eighteen central ribs, that is, six on each side of the vessel to each rib; and each bolt should require a force at least equal to 18 or 20 tons to draw it apart. The decks should not have less than three-quarter bolts. The whole of the bolts would be best to have strong-threaded screws, with adequate thick nuts and plates as large as the timber will admit of, and in those of the decks also; should the iron be thought to affect the compass, a great number of these might be copper bolts, of equal or of adequate strength. It must be understood, I merely mention about the number and strength of bolts that should be put in to make a firm and substantial vessel, with timbers the same size as at present, even before it is planked; but it is obvious that ship-builders will exercise their own discretion on that head, more or less, according to circumstances; so that some vessels will be so incredibly strong, that a storm, or being driven on shore, would have no effect on them, being equally secure and safe on land and water;

others would not, perhaps, build them so strong; but it is certain, that with the same quantity of timber, and a sufficiency of bolts, agreeably to the scale aforesaid, vessels may be constructed on this principle, of such strength and stability, that to hear of the wreck of one of them would be quite a novelty. With timber and bolts proportionate, there need be no limits to the dimensions or strength of vessels constructed on this plan,—which is what is most wanting in steam navigation, the desideratum being larger and much stronger vessels.

“It will be seen that very strong vessels may be constructed on my principles, with the timbers running horizontally or longitudinally from head to stern, and connected together as before described. But I have described them vertically, as used at present, which I think to be the best, strongest, and simplest method of carrying my improvements into effect; as it is so trifling a variation from the present mode, being simply improvements on the present methods of arranging and connecting their timbers, which, if strictly adhered to, and generally adopted, will put an effectual stop to the appalling annual loss of lives, treasure, and time, to which we have been so long subjected; substituting safety, certainty, and punctuality, in all the future naval and mercantile affairs of this wonderful and enterprising nation,—thus keeping our own proper position in the new era of enterprise opening to our view, in the general adoption of steam navigation for all naval and commercial purposes.”

The quantity of timber consumed in the construction of a hull of this kind, is much the same as in one of the ordinary kind—the quantity of bolts about double; but as a great quantity of iron and other work is superseded by Mr. Redmund's plan, the total cost would not be more.

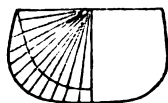
Mr. Annersley's patent plan of building ships and boats is exactly the opposite of Mr. Redmund's, just described; instead of depending upon the rib timbers for the main support of the hull of a vessel, he dispenses with them entirely, and derives the requisite strength from successive courses of planks crossing each other. The following account of the invention, derived from a periodical journal, will be found sufficiently explanatory.

The mode of proceeding is first to form a model of the required dimensions, and regulate the symmetry of the subordinate arrangements accordingly; this done, the model is cut across, by which the form and proportions for the mould are exactly obtained, as shown in the annexed *Fig. 1*. The moulds are

*Fig. 1.*



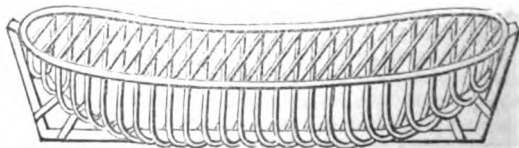
*(Centre Mould.)*



*(Section of Model.)*

then set up on the building blocks, in much the same manner as in other vessels; the moulds are of slender materials, merely strong enough to retain

*Fig. 2.*



*(Perspective View of Moulds set up.)*

together the perfect shape of the intended vessel: they are shown in *Fig. 2*. A longitudinal layer or course of planks is then fastened to the moulds all

round; namely, bottom, sides, and deck; sheets of tarred paper are then laid on, and a second course of planks is put upon the course, athwart, all round the first course, as shown in the subjoined figure, which crosses the grain of the wood, and most essentially contributes to the strength of the fabric; each course of planks is tree-nailed together, and the courses continued in alternate direc-

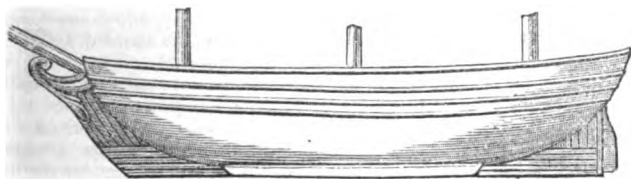
Fig. 3.



(The alternate fore and aft and cross planking.)

tions till a sufficient substance is acquired for the strength of the vessel. The keel, stem, and stern-posts, are put on with the last course, as shown in Fig. 4, and then the whole are tree-nailed through and through, each tree-nail being driven hard in, then split at the end and wedged. The dead wood fore and aft

Fig. 4.

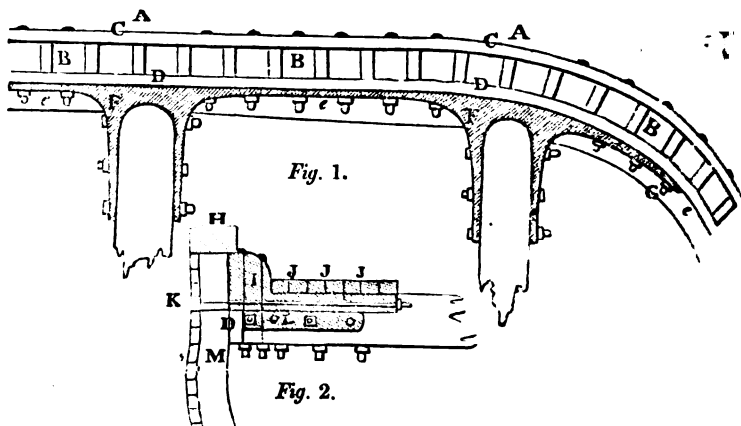


(Profile of the Vessel complete.)

is formed by cross planking, to fill up the space between the body of the vessel and the stern and stern-posts. To save the bottom, strengthen it, and keep the vessel upright when aground, two bilge keels are tree-nailed or bolted through into bilge planks in the inside of the vessel; stanchions, with brackets, are fixed to the sides and deck, and the bulwarks are formed prior to the last course of planking; the last course is then laid to finish the deck: the hatchway and companions are then cut out of the solid deck, and the comyns introduced. This system of building is said to require much less timber, being without knees, beams, and ribs, and is, therefore, more buoyant—causes no loss of time in building, for seasoning the timber—avoids the dry rot, from air and moisture being excluded from the inner courses—the resistance more elastic, and presenting, in every direction, an arch to sustain external shocks; and, it is added, that in case of warfare, the destructive effects arising from splinters will be entirely avoided.

Mr. E. Carey, of Bristol, who has had much experience in ship-building, and has suggested a variety of improvements, recommends the following method of fastening a ship's side, with his newly-invented iron knees, as explained by the subjoined figures. Fig. 1. is a horizontal section of a portion of a ship's side and beams; A A shows the ship's side; B B the timbers; C C the thickness of the outside planking, D D a plank,  $3\frac{1}{2}$  inches thick, which goes all round the ship, inside the timbers, against which the iron knees are fixed, and bolted through the side; e e an horizontal clamp, 10 inches wide and 6 inches thick, F F the iron knees, 4 inches wide and 2 inches thick, which are bolted through

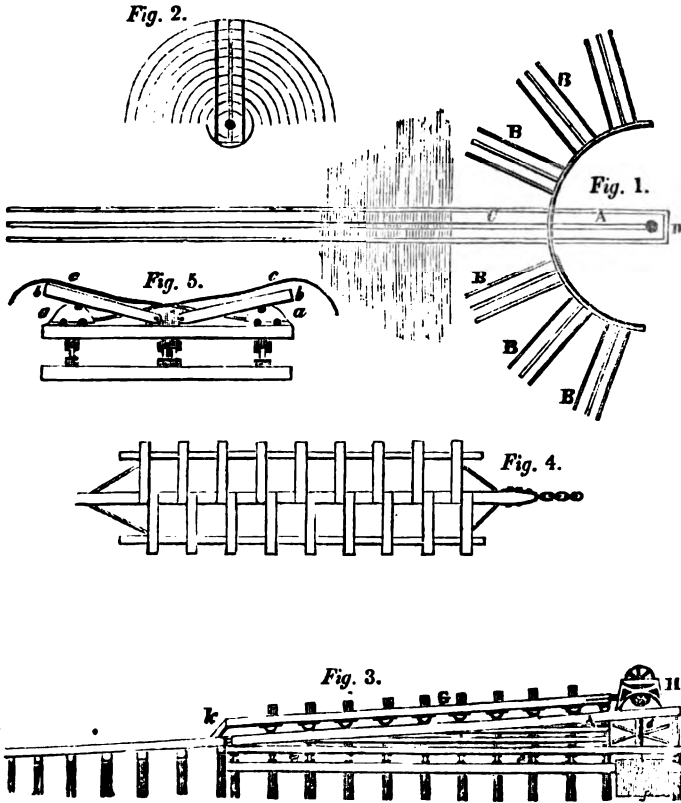
the beams and ship's side, as at G G. *Fig. 2* is a section of the same parts as *Fig. 1*. H is the plank sheer; I the water way; J J the ends of the planks; K a bolt that goes through the ship's side, through the edge of the water way, and six streaks of the deck below the beam, and is clenched on an iron plate



on the inner plank; L the arm of the knee; M the ship's timber and side; D is an edge-view of the inner plank, as shown at D, *Fig. 1*. These iron knees and water ways are let down upon the beam 3 inches, and also six of the deck planks, and bolted through also; under the beam a plank,  $3\frac{1}{2}$  inches thick, is first brought on, inside the ship, against which the ends of the beam are fixed. The horizontal clamp, 10 inches wide and 6 inches thick, is then brought on under the edge of the plank, and bolted through the side. On this clamp the beam is dovetailed in, one inch down, and bolted through the end of the beam. A ship fastened in this way, Mr. Carey says, will render it impossible for the side to move; that no wet can possibly get down, and that the ship will thus be kept perfectly dry and sound.

Under the head Dock have been described the usual mechanical arrangements and process for building and repairing ships. In this place we shall add a very ingenious and improved method of bringing up ships upon the ways for the operations of the ship builder. A Committee of Inventions appointed in the year 1827, by the Franklin Institute of Philadelphia, to whom the subject was referred, drew up the following report thereon, which seems to have been dictated by sound judgment and impartiality. "The Committee of Inventions, to whom have been submitted a model, drawings, and descriptions of the 'Radiating Railways for the repairing of Vessels,' invented by Edward Clark, of New York, civil engineer, report, that they have carefully examined the proposed improvement, and consider the plan as offering great facilities, when it is desirable to have several vessels under repair upon the ways at the same time. Morton's patent slip, which is in use in Scotland, is of sufficient length to contain two or three vessels; but it is evident that whichever was the last hauled up, must be the first launched; and they must, therefore, be frequently repaired in haste, without being allowed that time to dry, which is, in many cases, a point of great importance. To obviate this difficulty is the end proposed in the plan under consideration. It does not appear, from any thing which has been presented to the Committee, that Mr. Clark proposes anything novel in the construction of the lower part of the railway, or of the carriage upon which the vessel is to be drawn up; its distinguishing feature being the means provided for removing vessels out of the direct line of the main railway, and of depositing them upon sub-ways, for the purpose of being repaired. To

accomplish this purpose the upper part of the railway, for a length sufficient to receive a vessel, is detached from the lower part, and is made capable of revolving upon a firm horizontal platform, a perpendicular shaft from which passes through the upper end of the detached part of the railway. This platform is the segment of a circle, but it may, if necessary, present a complete circle. At the periphery of this segment, the fixed part of the railway terminates, and the detached revolving commences; this is supported upon the platform by a sufficient number of strong iron rollers, placed transversely on the lower part of the framework of which it is formed. The upright shaft, around which the



detached railway is capable of revolving, is also the shaft of the windlass, by which the vessels are to be drawn up; this detached way may therefore be considered as a radius to the circle, of which the platform is a segment. When a ship is drawn up and has arrived upon the movable part of the railway, a power may be applied to carry this with its load to the requisite distance round the circular platform, until it arrives at a sub-way, several of which are erected round the platform, forming produced radii to the circle. These are precisely similar to the main railway, with the exception of their not being continued to the water, but only of such a length as to admit of the carriage with its load being lowered, and deposited upon them until the intended repairs are made.



In the drawing which accompanies this report there are represented six sub-ways, and of course upon such a structure seven vessels might be placed at a time. The main expense attending the erection of marine railways, is in constructing that part which is under water, where nearly the whole of the labour must be performed in the diving-bell. In the mode proposed by Mr. Clark, one marine railway would be sufficient in those parts where many vessels may be required to be hauled up; a considerable number of sub-ways, with their appurtenances, might undoubtedly be provided at an expense far below that which would attend the original structure. After maturely considering the subject, the Committee are fully convinced of the practicability of the plan, and also of its economy, in those situations where more than a single railway would be desirable. When once constructed, it possesses the advantage of being capable of extension in the number of its sub-ways, whenever it may be required." Annexed are engravings from the drawings referred to. *Fig. 1* is a bird's eye view of the platform and railways. A, revolving section of the railway, which may at pleasure be made to coincide and connect with the radiating or sub-ways B B B, or with the main railway C, extending into the water. D is the shaft or pivot upon which the section A revolves. *Fig. 2* represents the revolving section, with its centre, as in *Fig. 1*, together with the circular iron railways, upon which the cast-iron rollers are to run. *Fig. 3* is an elevation or side view of the revolving and permanent railways, supporting a ship's carriage; A being the revolving section; B or C, section of the main, or the sub-railway; D shaft for communicating to the windlass the power which is generated at the levers *d*; this shaft is also the pivot around which the section A is made to revolve; *e e e*, &c., are iron rollers connected to and supporting the revolving section in the circular railways; G, ship's carriage resting on the inclined railways; H, windlass or other machinery for elevating vessels; *i*, chain by which the carriage is drawn up; *k*, palls to prevent the carriage from running back; *l*, friction-rollers, lying between the movable and fixed ways. *Fig. 4*, ground view of a ship's carriage. *Fig. 5*, transverse view on a larger scale of a ship's carriage on the railways; *a a* cuneiform blocks, movable on rollers, in appropriate grooves, to prevent lateral motion; *b b*, bilge blocks moving on pivots, and resting on rollers adapted to *a a*; *c c*, ropes by which the cuneiform or wedge blocks are drawn up, and the bilge blocks forced against, and adapted to, the bottoms of vessels.—*Franklin Journal*. For a variety of information of the constituent parts of ships, with their recent ameliorations, see the separate heads, as **MASTS, RUDDERS, CAPSTAN, WINDLASS, BLOCKS, ANCHORS, FIDS, BOATS, &c. &c.**

**SHINGLES**, in *Building*, small boards, nearly resembling, in shape and size, the staves of a common pail, but tapering regularly thinner and thinner from the broad to the narrow end. They were formerly used instead of tiles, for the covering of roofs, and are well adapted to those that are of a high pitch, but not so well for the modern low roofs. The steeples of many of our country churches are covered with shingles. The method of covering a building with shingles is extremely simple; at equal distances from the thip end there are inserted two stout wooden pegs, projecting on the inner side about two inches: by these pegs the shingles hang on pantile laths, nailed horizontally across the rafters, and at such distances, as to allow each row of shingles to lap over the next lower row by about half the length of a shingle. Sometimes, however, the roof is previously covered with boards, on which the shingles are nailed; but this method has the disadvantage of being far too expensive for common practice, especially in a country like ours, where oak is by no means plentiful, and what we have is wanted for purposes of greater national importance.

**SHOT.** A missive weapon discharged by the force of ignited powder from a fire-arm in warfare: of these there are various kinds, as round shot, or bullets, a ball or sphere of iron whose weight is in proportion to the bore of the cannon. Double-headed, or bar-shot, are formed of a bar of iron with a ball at each end, which fits the muzzle of the cannon. The middle is sometimes filled with composition, and the whole covered with linen dipped in brimstone: so that the cannon, in firing, it is said, thus inflames the combustibles or com-

position, which sets fire to the sails of the enemy. One of the heads of this ball has a hole to receive a fusee, which, communicating with the charge of the cannon, sets fire to the bullet.

Chain shot consist of two balls chained together, being principally designed to annoy the enemy by cutting her sails, rigging, &c. Grape shot is a combination of balls strongly corded in canvass upon an iron bottom, so as to form a cylindrical figure, whose diameter is equal to that of a ball which is adapted to the cannon. Case shot, or cannister shot, are composed of a great number of small bullets, put into a cylindrical tin box. They are principally used when very near, to clear the decks of the enemy. Besides these, there are others of a more pernicious kind, such as langrage shot, star shot, fire arrows, &c., employed also when not at a great distance from the enemy.

Cannon shot that are cast in moulds, usually possess, in a greater or less degree, the three following defects:—first, being imperfect in their spherical figures, which is owing to the expansion and alteration of form made in the moulds, from frequently heating them; second, containing air cavities, owing to the air being caught in the moulds when the fluid metal runs in too quickly for it to escape; third, their having usually an indentation where the metal is poured in. To obviate these defects, Mr. Boothby, of Chesterfield Iron Works, manufactures his cannon balls in the following manner, for which he has taken out a patent. A solid ball of hard wood or metal is turned to a true sphere (according to the size or weight of shot required), and then cut in halves. These halves are moulded in sand boxes, in the usual manner of other castings, taking care that the sand be well rammed; then taken out, and the hollow moulds thinly coated with powdered charcoal mixed with water. The boxes containing the moulds are next dried in the stove, preparatory to receiving the fluid metal. The shot thus cast are said to be perfectly sound and spherical, owing to the air escaping through the sand, and the mould being unaltered in its figure by heating.

**SHROUDS.** A range of large ropes, extended from the mast heads to the right and left sides of a ship, to support the masts, and enable them to carry sail. The shrouds, as well as the sails, &c., are denominated from the masts to which they belong; thus there are the main, fore, and mizzen shrouds; the main top-mast, fore top-mast, and mizzen top-mast shrouds; and the main top-gallant, fore top-gallant, and mizzen top-gallant shrouds. See SHIP.

**SHUTTLE.** The instrument employed in weaving, by which the crossing of the threads is mainly effected. See WEAVING.

**SICKLE.** An instrument for cutting down corn. It is simply a curved blade or hook of steel, with the edge, in the interior of the curve, serrated, so as to make a cut like a saw. The subjoined engraving, which represents the native instrument used by the Singalese, shows that the sickles employed by the



semi-barbarous nations of the East differ in no essential respect from those used in this country.

**SIEVE.** An instrument for separating the smaller particles of substances from the grosser; they are made of various forms and sizes, to suit the article to be sifted. In its most usual form it consists of a hoop, from 2 to 6 inches in depth, forming a flat cylinder, and having its bottom constituted of coarse or fine hair, canvass, muslin, lawn, net-work, or wire, stretched tightly over, according to the use intended.

There is a kind of sieve in extensive use amongst druggists, drysalters, and confectioners, termed a drum-sieve, owing to its form, and is used for sifting very fine powders. It consists of three parts or sections; the top and bottom sections of which are covered with parchment or leather, and fit over and under a sieve of the usual form, which is placed between them. Being thus closed in, the operator is not annoyed by the clouds of powder which would otherwise be produced by the agitation, and the material under operation is thus saved from waste.

**SILEX**, silica, silicium, or silicious earth, is one of the most abundant substances in nature, constituting the entire mass of many mountains, and probably of a large portion of the globe itself. It is the chief component of sand, sandstone, flint, granite, quartz, porphyry, rock-crystal, agate, and many precious stones; it is the chief substance of which glass is made; also an ingredient, in a pulverised state, in the manufacture of "stoneware," and it is essential in the preparation of tenacious mortar. Silix, when pure, is a fine powder, hard, insipid, and inodorous; rough to the touch, scratches and wears away glass. It does not form an adhesive mass with water, but falls to the bottom, leaving the water clear: however, if the silix be very minutely powdered, a small portion of it will be dissolved by the water. Silix may be obtained in a pure state by igniting powdered quartz with three parts of pure potash in a silver crucible, and adding to the solution a quantity of acid sufficient to saturate the alkali; then by evaporating to dryness, there will remain a gritty powder, which, when washed with water, will be pure silix.

**SILK**. A very soft, fine, bright thread, the production of different species of caterpillars; but the *bombyx mori*, or silk-worm, is chiefly cultivated for this purpose; it is a native of China, and the culture of silk in ancient times was entirely confined to that country.

The natural history of the silk-worm forms a subject highly interesting and curious; but the extraordinary changes which the animal undergoes, as well as its manner of spinning its ball or cocoon, having probably fallen under the actual observation of most of our readers, we shall pass over this part of our subject, and proceed to the business of winding, throwing, and weaving.

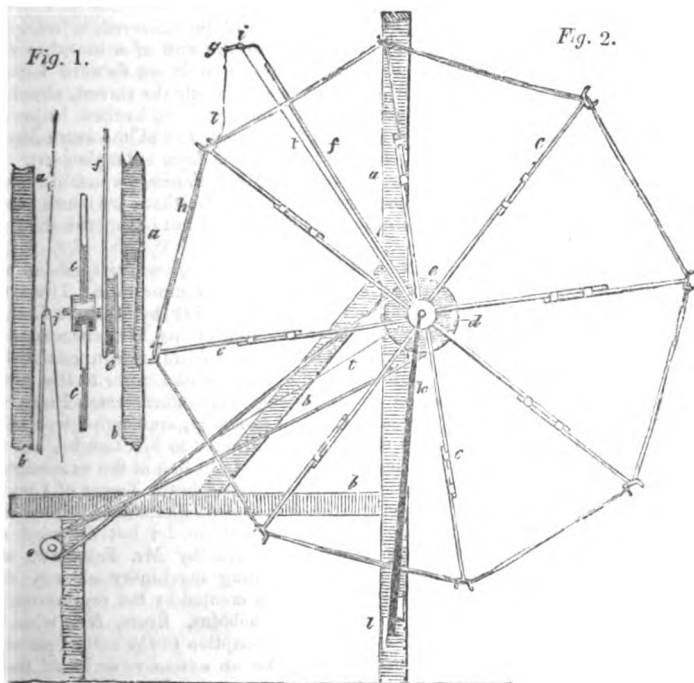
In those countries where silk forms an important article of commerce, the cultivators, or those who rear the insects, do not wind off the silk themselves, but sell them to others, who make the operation of reeling a distinct business. The single filament, or thread of silk, as produced by the worm, is of such extreme tenuity as to be totally unfit for the purposes of the manufacturer. Therefore, in winding it off, several of the cocoons are immersed in warm water, to soften the gum with which the silk is naturally connected; their several ends are then joined and reeled off together; and, by the adhesiveness of the gum, are thus formed into one smooth even thread. When the thread of any cocoon breaks, or comes to an end, its place is supplied by a new one, which is simply laid on the main thread, to which it adheres by its gum; and, owing to its extreme fineness, it does not occasion the least perceptible unevenness in the place where it is united. In this manner of joining the separate filaments, a thread may be made of any length.

The apparatus for reeling consists merely of an open kettle of water, under which is a fire to keep it warm; and the reel is of the common construction. However simple the operation, great care and attention are necessary in reeling, to preserve the thread of an equal thickness, and of a round form, and that the several rounds upon the reel should not get glued together. When the skein is quite dry, it is taken off the reel, and being made up into hanks, it forms the article called, in commerce, raw silk, of which such vast quantities are annually imported into this country from Bengal, China, Italy, and Turkey.

In preparing raw silk for dyeing, the thread is slightly twisted, in order to enable it to bear the action of the hot liquor without the fibres separating or furring up. The silk yarn employed by the weavers for the woof or weft of the stuffs which they fabricate, is composed of two or more threads of the raw silk slightly twisted by the aid of machinery; and the thread employed by the

stocking weaver is of the same kind, but composed of a number of threads corresponding with the strength or quality of the work he is executing.

The first operation it undergoes is winding; that is, drawing it off from the skeins in which it is imported, and winding it upon wooden bobbins, from whence it is taken off for subsequent operations. In the ordinary method of winding off silk, the reel or swift, upon which the skein is placed, is made to revolve by the pulling of the thread, as it is drawn off and wound upon the bobbin. The great delicacy of the filaments of silk often, however, render this operation difficult, owing to the breaking of the threads; in the winding of Turkish silk, in particular, the process is, from the circumstance just mentioned, extremely tedious, as the thread breaks at almost every turn of the reel; this is owing to the great size of the Turkish skeins, which frequently exceed twenty-four feet in circumference; thus requiring a reel of equal dimensions, that has to be turned round by a single thread; and this thread, being of an uneven thickness, frequently gets entangled in the skein, and unavoidably breaks. To obviate so great an inconvenience and detriment to the material (by an infinity of knots in the thread), the attention of Mr. H. R. Fanshaw was directed, and by means the most simple and ingenious he accomplished his object in the most happy and perfect manner; this invention, for which he took out a patent in 1827, we shall here describe.



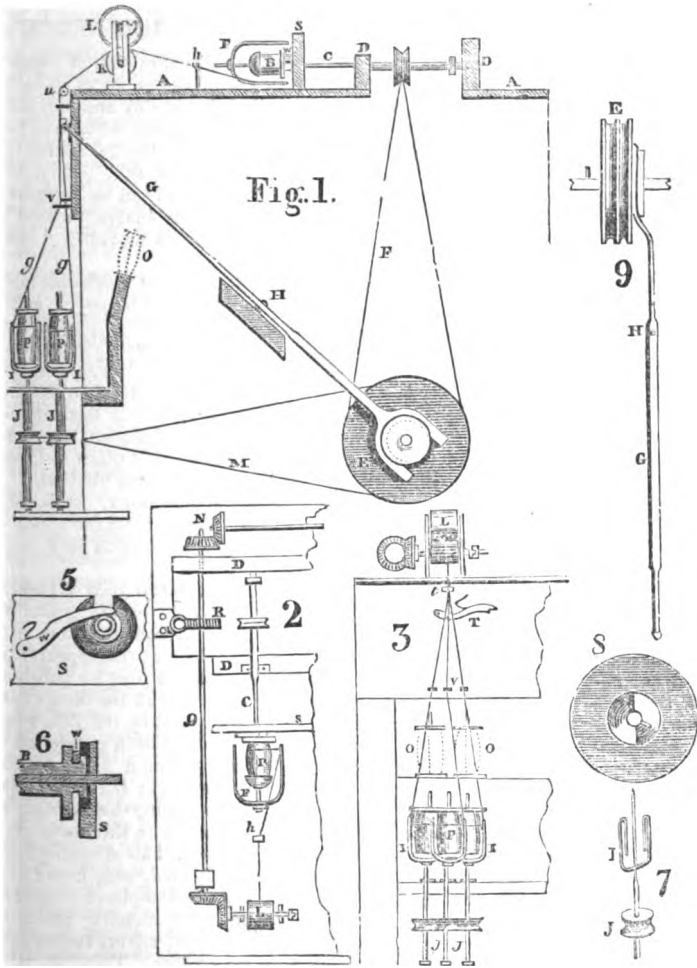
Instead of the reel being turned round by the filament, it remains stationary, but is suspended loosely upon its axis; a light arm or flyer is then made to revolve around the external circumference of the reel, which lifts out the thread from the skein more smoothly and delicately than it could be performed by the finger, conducts it to the centre of motion, and from thence to the bobbin on which it is wound. By this contrivance the thread requires but little more

strength than is sufficient to sustain itself, instead of having to drag round a great machine; and it follows that a much finer thread may be wound off by such apparatus than by those of the common construction. Our limits do not permit us to give all the details of this machinery; we shall therefore confine ourselves chiefly to explaining the principal or most important parts, as represented by the annexed diagram. *Fig. 1* gives a side elevation, and *Fig. 2* a front elevation of a portion of *Fig. 1*; the same letters in each referring to similar parts. *a b* is a frame, containing a swift, &c., of which there may be conceived to be a hundred or more in a row, one behind the other, as viewed in *Fig. 1*, all turned by the same shaft; the diameter of the swift may be considered as eight feet for Turkey silk, but the arms *c c* are made to elongate or shorten by the slides shown in the middle, so that the swift may be expanded or contracted at pleasure to suit the size of the skein; each of these radiating arms is fixed into a central block or nave *d*; through this nave a spindle passes, on which the swift loosely rests, as best seen in *Fig. 2*; *e* is a pulley, which revolves on the same spindle, and receives its motion by an endless band from another pulley at *o*. To the pulley *e* is affixed the revolving arm *f*, which is furnished at its extremity with a bent wire, coiled up into two spiral eyes; through that at *g* the filament of silk *t t* passes as it is lifted by it out of the skein *h*; from *g* it passes through the eye *i*; from hence it is drawn through another eye *i*, to the central eye *k*, (*Fig. 2*), and through the last-mentioned one to a bobbin fixed on the same shaft as the pulley *o*. The situation of the eye *k* opposite the centre of the axis of the swift, it will be observed, is indispensable to the winding off the thread; it is fixed to the end of a movable rod, which has a joint at *l*, that permits it at pleasure to be drawn forward beyond the range of the swift, for the girl in attendance to repair the thread, should it be broken. The latter circumstance, however, rarely occurs, by these improved arrangements, and the trembling motion of the bent wire at the extremity of the revolving flyer greatly assists in relieving the silk from entanglement.

The revolving flyer is the principal feature in Mr. Fanshaw's machine, and is in itself a very beautiful and no less useful invention: there are many subordinate contrivances of great ingenuity, which we have left out of the diagram to prevent confusion.

After silk has been *reeled* and *wound*, the next operations are *spinning* and *throwing*, which may be performed separately, or at the same time. The art of throwing silk was first introduced into this country in 1719, by Mr. John Lombe, who, with considerable ingenuity, and at the risk of his life, succeeded in taking a plan of a throwing machine in Sardinia, and, on his return, established a mill at Derby for conducting that operation, which had, prior to the above date, been kept a profound secret by the foreign manufacturers. From the great expense incurred in establishing the mill at Derby, application was made to Parliament to extend the term of the patent granted to Mr. Lombe, but the Legislature wisely granted him the sum of 14,000*l.*, in lieu of the extension of the patent right, and upon condition that he deposited in the Tower of London a complete working model of the machine, where it now remains. Since that period many improvements have been successively made, but amongst the most complete and efficient are those introduced by Mr. Fanshaw, and patented by him a short time prior to the winding machinery already described. To avoid that confusion which would be created by the representation of the vast multiplication of pulleys, wheels, bobbins, flyers, &c., which a throwing-mill embraces, we shall confine our description to the acting parts of a single operation, leaving the reader to imagine an extensive series of them. The engravings on the following page are explanatory of these improved arrangements. *Fig. 1* is an end view of the throwing machine; *A A* is the top of the frame; *B* the bobbin; *C* the top spindle; *D* the board which supports the spindle; *E* the pulley which gives motion to the set of spindles; *F* is the flyer to the top spindle; *G* the lever, which throws the pulley in and out of gear; *H* the lever pin or centre, on which it works; *I* the flyer of the bottom spindles; *J*; *K* is a fluted roller, which propels the drawing roller *L*, and gives out the thread to be thrown by the spindle *C*. The silk, after being wound on the

bobbin P, is twisted by the revolving spindles J, which are driven by the band M; the threads *g g* pass separately through the eyes *o*, and being united at *t*, go over the glass rod *u*, round the roller L, through the eye *h*, and are then



received upon the bobbin B, the twist being effected by the revolving spindle C, which is driven by the band F. Fig. 2 is a bird's-eye view of the machine; the same letters referring to similar parts; R is a tooth-wheel (not shown in Fig. 1) which drives the shaft Q, and gives motion to the rollers K; and at the other end to the bevel gear N, which is connected by a rod to the motion board that draws the bobbin backward and forward, to spread the thread uniformly over its surface. Fig. 3 is a front view of the machine for making three-thread organzine or sewings, the parts having been already described above, except the bobbins *o o*, which are shown in dotted lines, and are to be used in case tram is required to be made, instead of organzine. T is a catch to retain

the lever *G* (*Fig. 1*) in its place when the bobbins are thrown in or out of gear. *Fig. 5* represents the end of the bobbin *b*, which is kept in its place by the small lever *w*, which lever is fastened on to the motion board *s*. *Fig. 6* is a sectional view of *Fig. 5*. *Fig. 7* is the spindle *J*, as seen in *Figs. 1* and *3*, *I* being a fixed flyer. *Fig. 8* is a view of the opposite side of the pulley *E*, to that shown in *Fig. 1*. *Fig. 9* is an edge view of the pulley *E* and lever *G*, as described in *Fig. 1*.

The advantages of this machine are said to be, 1st, The throwing of organzine by one process, instead of the three separate processes, as at present practised; the spinning by one machine, doubling the threads by another, and throwing by a third. 2dly. In the very great increase of speed which can be obtained. 3dly. In the easy manner in which the machine can be altered to singles, tram, organzine, sewings, or any other description of silk. 4thly. In the saving of labour, from the great quantity of spindles that can be attended to by one hand. 5thly. In the little experience required to enable "a hand" to attend the work, thereby obviating the greatest expense in throwing "mill hands."

**SILVER**, is the whitest of metals, and next to gold the most malleable and ductile. Under the hammer, the continuity of its parts is not destroyed until its leaves are not more than the one hundred and sixty thousandth part of an inch thick; in this state it does not transmit light. Its specific gravity is 10.474. It continues melted at 28° of Wedgewood, but a greater heat is requisite to bring it into fusion. Its tenacity is such, that a wire of one-tenth of an inch in diameter will sustain a weight of 270lbs. without breaking. Silver has neither smell nor taste; these properties, together with its brilliant whiteness, hardness and tenacity, eminently adapt it to the uses of the table; and when to these qualities is added its intrinsic value, its advantages as coin become obvious.

**SILVERING**. The art or act of covering certain substances, as metal, wood, paper, leather, parchment, &c. with silver, so as to give them the appearance of that metal. Silver leaf is laid on much in the same way as gold leaf, for which see **GILDING**.

The method of silvering copper is as follows: take of tartar and common salt, each two drachms, half a drachm of alum, fifteen or twenty grains of silver, precipitated from nitric acid by copper; mix these well together, and with the mixture rub the surface of the copper, and it will have the appearance of silver; after the loose powder is brushed off, the surface may be polished with a piece of leather. Pins are silvered by boiling them with tin-filings and tartar. The buckles, studs, plates, &c. of harness are silvered by the following cheap and easy process: take half an ounce of silver that has been precipitated from aqua-fortis by copper; muriate of ammonia and common salt, of each two ounces, and one drachm of corrosive muriate of mercury; triturate these together, and form them into a paste with water. After boiling the substances to be silvered with tartar and alum, they are to be rubbed with the above preparation, then to be made red hot, and afterwards polished. This silvering may be effected by using the argentine precipitate above mentioned, with borax and mercury, and causing it to adhere by fusion. To silver the dial-plates of clocks, the scales of barometers, thermometers, &c., and all other metallic plates of similar description, rub upon them a mixture of muriate of silver, tartar, and sea-salt, and afterwards wash off the saline matter with water. This silvering is not durable, but it may be improved by heating the article, and repeating the operation once or oftener, if it be thought necessary. The following amalgam is used for silvering the interior surface of hollow glass globes: fuse together two parts by weight of bismuth, one part of lead, and one of pure tin; when this is nearly cold, add four parts of mercury, and fuse the whole over a gentle heat. The glass globe being thoroughly clean, introduce into it a paper funnel, which reaches to the bottom, and pour in the liquid amalgam. At a proper temperature it will adhere to the glass, which, by being turned and shaken, will thus have its interior surface completely covered, and any remainder of the amalgam may be poured out when the operation is completed.

**SIZE**. A kind of weak glue, used in many trades; it is made of the shr eds

and parings of leather, parchment, or vellum, boiled in water, and strained. Common size is made of leather, boiled in water till it becomes of a viscid consistence. If it is wanted in painting for nicer purposes, it should be prepared by taking any quantity of the shreds or cuttings of glovers' leather, and putting to each pound a gallon of water; let these be boiled for six or eight hours, supplying water, so that it may not diminish to less than two quarts; then strain the hot fluid through a flannel, and afterwards evaporate it, till it is of the consistence of a jelly when cold. The size used in burnish gilding, and made of cuttings of parchment, is prepared much after the same manner.

**SLOOP.** A small vessel furnished with one mast, the main sail of which is attached to a gaff above, to the mast on its foremost edge, and to a boom below. It differs from a cutter by having a fixed steering bowsprit, and a jib-stay; the sails are also less in proportion to the size of the vessel.

**SLUICE.** A frame of timber, stone, or other matter, serving to retain and raise the water of a river, &c., and, on occasion, to let it pass. Such is the sluice of a mill, which stops and collects the water of a rivulet, &c., to let it fall, at length, in the greater plenty upon the mill wheel; such also are those used as vents, or drains, to discharge water off land. See **TIDE-MILL**, **WATER-WHEEL**, &c.

**SMACK.** A small vessel, commonly rigged as a sloop or hoy; used chiefly in the coasting and fishing trade.

**SMALT.** A combination of glass with the oxide of cobalt, in the state of a very fine blue powder. See **ZAFFRE** and **COBALT**.

**SMELTING.** The operation of fusing ores, in order to separate the metals from the other minerals by which they may be combined. See **IRON**.

**SMUT**, in *Agriculture*, a disease to which wheat is peculiarly liable, by which it becomes contaminated with a sooty looking powder, which sometimes destroys the whole substance of the grain. Many contrivances called smut-machines, have been at different times invented to cleanse wheat, before grinding, from this serious defect; but they have proved only partially successful in their operation, owing, we conceive, to the process simply consisting of violent agitation, which cannot be effective in removing the hollow damaged grain from the mass, although it may drive off much of the loose or external foulness.

**SNATCH-BLOCK.** A block having an opening in one of its sides, wherein to fix the bight of a rope occasionally. This is by some termed a rouse-about block. See **BLOCKS**.

**SNOW.** The frozen vapours of the atmosphere; its whiteness is owing to the small particles into which it is divided, for ice, when pounded, becomes equally white.

**Snow.** A vessel equipped with two masts, resembling the main and fore-masts of a ship, and a third mast just abaft the main-mast, carrying a small sail similar to a ship's mizzen.

**SNOW-PLOUGH.** A simple machine operating like a plough, but upon a larger scale, for clearing away the snow from roads. It usually consists of boards framed together, forming an angular figure, the point of which enters the snow, which is thrown by the boards to the sides of the road, leaving a furrow similar to those in a ploughed field.

**SNUFF.** A scented powder, the use of which is well known. The stalks of tobacco leaves, ground small, are the basis of all snuffs; and the various kinds derive their names from the whims of the manufacturers, who combine with them those odoriferous substances by which they are distinguished.

**SOAP.** A name given to those bodies which are compounds of the alkalies with fat and the fixed oils. The earths, and the other metallic oxides also, combine with fat and oils, forming neutral compounds. The former have been called earthy, and the latter metallic soaps. The soaps formed by the alkalies have the distinguishing character of being soluble in water and alcohol. The earthy soaps are perfectly insoluble: and since any of the earths have a stronger attraction for oil than the alkalies, the alkaline soaps are always decomposed by the earths. This occasions the curdy appearance when soap is used with water containing any earthy or metallic salt: it is from this quality that waters are said to be hard.



The soaps used in the manufactures and domestic economy, are made with the fixed alkalies, combined with different kinds of fat and oil. These, in the manufacture of soap, are divided into two principal varieties, viz. hard and soft. The alkali employed for hard soap is soda, generally obtained from the different sea vegetables, and called by different names, according to the name of the plant, in different countries. Most of the algæ, but particularly the fucus and *salsola*, afford soda by burning. The vegetables are first dried, and then burnt in pits formed with loose stones. The earthy matter, and the soda, with some neutral salts, fuse into a crude mass, in which state it is sold. This substance is furnished in great abundance from the Highlands of Scotland, under the name of kelp, and from Alicant, in Spain, under the name of barilla. In France it is known by the name of varec; this being the name of the plant from which it is generally produced there. It is commonly, however, in this state that it comes to the soap-maker, varying frequently in its value, and often occasioning much uncertainty in its employment. It should be the first business, therefore, of the manufacturer to assay the substance from which he gets his alkali, even before he purchases it. When the exact value of the alkali is known, it is then to be treated as follows, to prepare it for mixing with the fat. The kelp, or barilla, is first to be pounded, and then mixed with one-fifth its weight of quick lime, in a large vat. These vats are generally three or four in number to each boiler. Besides these vats for the infusion of crude alkali, each of them has a cavity made under it. The bottom of each vat is even with the ground, the under cavity being sunk below, and is intended to receive the liquor which runs from a plug-hole in the upper vat, when the infusion has gone on to a certain extent. One of these vats, with its under reservoir, is sufficient for one boiling, but they are generally all at work, in order to give time for the solution of the alkali from the crude mass. In charging a vat, the barilla, kelp, or potash, and sometimes mixtures of these, are first coarsely powdered and mixed with quicklime, also coarsely powdered; some water is then thrown upon these, to slake the lime. In the side of the vat some straw is first placed about the plug-hole, to prevent bits from passing through. The vat is now charged, and water poured upon the materials till it stands considerably above the solid mass; after standing several hours the plug is withdrawn, to let out the solution into the lower reservoir. The plug is now returned, and fresh water poured upon the materials. Some, or all of the first ley is now removed into one of the other lower reservoirs before the second infusion is drawn off. This is done that the soap-boiler may always have at command two leys of different degrees of strength, as, in the course of every boiling, he finds it necessary to use sometimes the weak, and, at other times, the strong. The number of waters to be added to the materials, depends upon the judgment of the workman, who, by his taste, can tell when the water has dissolved the whole of the alkali. The ley being ready to lade out of the reservoir, which is near to the boiler, the tallow or oil, first weighed, is put in. When it is sufficiently melted, the workman begins by adding the ley and stirring the mixture. The alkali and the oil soon begin to unite, forming a milky fluid. As more ley is added, and the stirring continued, the liquid thickens. This is continued generally for thirty hours, and frequently more, till small portions of the soap, taken out from time to time, assume a proper consistence, which the workman, by constant experience, understands. He now adds a quantity of common salt, which has the effect of separating the watery part from the soap, which contains a portion of neutral salts, that existed in the crude alkali, especially when more than enough has been added. The fire has now to be withdrawn, and the mass left to cool. The watery part will be found at the bottom, and requires to be drawn out by a pump, which is a fixture on the side of the boiler. When this has been removed the fire is re-kindled, and if the mass does not melt freely, a little water is added. As soon as the whole becomes liquid, and is made uniform by agitation with wooden poles, the fire is again withdrawn, and the mass allowed to assume a proper consistence for lading. It is laded into square moulds; these are composed of a number of strata lying one upon another, so that when the soap has become solid, each layer of frame-work can be removed, beginning at the top, and the

soap is cut into cakes with a small piece of brass wire at every interval; these cakes are afterwards cut into square prismatic pieces, in which state they are sold. Yellow hard soap is formed of similar proportions of soda and tallow with the last; but it also contains resin, and sometimes palm oil. In boiling the yellow soap, the resin, oil, and tallow, are put into the boiler first. The ley is prepared in a similar vat, and managed, in other respects, like the white soap.

Soft soap differs in its composition from hard, in containing no alkali, but potash. Soft soap made with colourless fat, such as tallow, is a white unctuous substance, about the consistency of lard. If the fat be coloured, the soap partakes of the same. In France, and other parts of the continent, it is generally coloured, sometimes with metallic oxides. Those made with yellow oil are sometimes coloured with indigo, which gives them a green colour. The oils employed are seldom olive oil, but the cheaper oils, such as rape-oil, the oil of hempseed, linseed, and others. In Holland it was made with whale-oil. This oil was forbidden on some parts of the continent, on account of its disagreeable smell. In this country, however, all the soft soaps are made with whale-oil, which gives a transparent mass of a yellow colour. In commerce, however, we do not find it uniform in its colour; besides the yellow part, it appears interspersed with white spots, giving the whole a strong resemblance to the inside of a dried fig.

**SOAP-STONE.** A species of steatite. It imparts to the touch a peculiar unctuous feeling, like fine white soap. The soap-stone of this country is chiefly obtained from the Lizard, in Cornwall, where it is found in connexion with serpentine, to which it is nearly allied. It is much used in the manufacture of porcelain; also for polishing marble and other stone. It is the basis of various cosmetics, and is combined with carmine to form rouge; it is also found very useful in taking grease spots out of silks, stuffs, &c.

**SODA.** One of the fixed alkalies: it is generally procured from the ashes of marine plants; indeed, its great repository is the ocean, soda being the basis of sea salt. Combined with carbonic acid, soda is found in a mineral state in Egypt, where it abounds under the name of natron; whence it is frequently called mineral alkali.

**SODA-WATER.** See **AERATED WATER.**

**SODIUM.** The metallic basis of soda, according to Sir H. Davy. See **CHEMISTRY.**

**SOLDER.** A metallic cement for joining separate pieces of metal together by fusion. It is a general rule, with respect to solder, that it should fuse at a lower temperature than the metal to be soldered. The solders of the plumber are composed of tin and lead, on account of their ready fusion. (See those metals.) The coppersmith's solder is an alloy of copper and zinc. (See those metals.) In general, the solder is harder or softer, in proportion to the quantity of copper that is in it; the greater the quantity of copper it contains, the harder and more difficult of fusion it becomes. Solders of different degrees of fusibility are often required, particularly in cases where several joinings have to be made near to near other. The least fusible solder is employed in the first place, and the others in succession, according to their order of fusibility, to the subsequent joinings. If this precaution were not adopted, it would often happen that in soldering one joint, the heat communicated to the next thereby would cause it to become unsoldered. Before soldering, the surfaces are rendered bright and clean, by scraping or filing them over; as a thin coat of oxide, or any foreign matter intervening, would prevent the union.

The solders used for brass are usually of two kinds, denominated hard and soft. The hard is composed of brass and zinc, varied in the proportions of from sixteen to two parts of brass to one of zinc. The soft solder is composed of six parts brass, one of zinc, and one of tin. The brass is first melted, then the tin, and lastly the zinc (previously well heated) is added. The mixture is then agitated to divide it into grains as it cools.

**SPECIFIC GRAVITY.** The weight of any body, or substance, compared with the weight of some other body which is assumed to be a standard. The

standard of comparison, by common consent and practice, is rain water, on account of its being less subject to variation, in different circumstances of time and place, than any other body, whether fluid or solid. A cubic foot of rain water weighs 1000 ounces avoirdupois; therefore, assuming this to be the specific gravity of rain-water, and comparing all other bodies with it, the same numbers which express the specific gravities of bodies, denote, at the same time, their weight per cubic foot, in avoirdupois ounces. Hence, by reference to the tables, we are enabled to find the magnitude of any solid which is too irregular to admit of the common rules of mensuration, and also the weight of any body of known magnitude which is too ponderous to be submitted to the operation of the steel-yard or balance.

*Example.*—Required the quantity of material in an irregular shaped block of marble, weighing  $4\frac{1}{2}$  tons.

Reduce the weight to ounces, and divide by the specific gravity of marble.

Hence  $4\frac{1}{2}$  tons  $\times$  16 oz.  $\div$  2.838 = 56.8 cubic feet.

Required the quantity of material in a statue of white Parian marble, weighing 800 pounds.

$800 \times 16 = 12800 \div 2.838 = 4\frac{1}{2}$  cubic feet.

*Again.*—Required the weight of a block of Aberdeen granite, measuring 43 feet in length, 8 feet in breadth and thickness.

$43 \times 8 \times 8 = 2752$ .

Then, as  $1 : : 2752 : : 2.625 : : 7224000 = 201$  tons 11 cwt. 1 qr.

The properties of specific gravity are as follows:—

1. A body immersed in a fluid will sink if its specific gravity be greater than that of the fluid; if it be less, the body will rise to the top, and be only partly immersed; and if the specific gravity of the solid and fluid be equal, it will remain at rest in any part of the fluid in which it may be placed.

2. When a body is heavier than a fluid, it loses as much of its weight, when immersed, as is equal to a quantity of fluid of the same magnitude.

3. If the specific gravity of the fluid be greater than that of the body, then the quantity of fluid displaced by the part immersed is equal to the weight of the whole body. Hence, as the specific gravity of the fluid is to that of the body, so is the whole magnitude of the body to the part immersed.

#### Specific Gravities of Metals.

	Sp. Grav.		Sp. Grav.
Antimony, in a metallic state,		Platina, crude, in grains . . .	15.602
fused . . . . .	6.624	purified . . . . .	19.502
Bismuth, cast . . . . .	9.823	the same hammered . . . . .	20.337
native . . . . .	9.822	,, rolled . . . . .	22.069
Brass, common cast . . . . .	7.824	,, wire-drawn . . . . .	21.042
cast, not hammered . . . . .	8.396	Silver, cast, pure . . . . .	10.474
wire-drawn . . . . .	8.544	,, hammered . . . . .	10.511
Copper, cast . . . . .	8.788	French coin . . . . .	10.049
wire-drawn . . . . .	8.878	shilling (George III.) . . . . .	10.534
Gold, pure, cast . . . . .	19.258	Steel, soft . . . . .	7.833
the same hammered . . . . .	19.362	hardened, but not tem-	
22 carats, fine, standard . . . . .	17.486	pered . . . . .	7.840
Iron, cast . . . . .	7.207	tempered, but not har-	
bars . . . . .	7.788	dened . . . . .	7.816
Lead, cast . . . . .	11.352	tempered and hardened . . . . .	7.818
litharge . . . . .	6.300	Tin, pure Cornish . . . . .	7.291
Mercury, solid, 40° below 0		Malacca, fused . . . . .	7.296
Fahr . . . . .	15.632	Tungsten . . . . .	6.066
at 32° of heat . . . . .	13.619	Uranium . . . . .	6.440
at 60° . . . . .	13.580	Wolfram . . . . .	7.119
at 212° . . . . .	13.375	Zinc, in its usual state . . . . .	6.862
Nickel, cast . . . . .	7.807	pure and compressed . . . . .	7.191

*Specific Gravities of Woods.*

	Sp. Grav.		Sp. Grav.
Alder . . . . .	.800	Lignum-vitæ . . . . .	1.333
Ash . . . . .	.845	Lime-tree . . . . .	.604
Beech . . . . .	.852	Logwood . . . . .	.913
Box, Dutch . . . . .	.912	Mahogany . . . . .	1.063
Campechy . . . . .	.913	Maple . . . . .	.750
Cedar, American . . . . .	.561	Mulberry . . . . .	.897
Indian . . . . .	1.315	Oak, heart of, 60 years old . . . . .	1.170
Palestine . . . . .	.613	Olive-tree . . . . .	.927
Cherry-tree . . . . .	.715	Orange-tree . . . . .	.705
Citron . . . . .	.726	Pear-tree . . . . .	.661
Cork . . . . .	.240	Pomegranate-tree . . . . .	1.354
Cypress . . . . .	.644	Poplar . . . . .	.383
Ebony, Indian . . . . .	1.209	Plum-tree . . . . .	.755
Elder . . . . .	.695	Quince-tree . . . . .	.705
Elm . . . . .	.671	Sassafras . . . . .	.482
Filbert . . . . .	.600	Vine . . . . .	1.327
Fir, yellow . . . . .	.657	Walnut . . . . .	.671
white . . . . .	.569	Willow . . . . .	.585
Hazel . . . . .	.600	Yew, Spanish . . . . .	.807
Juniper . . . . .	.556	Dutch . . . . .	.788
Lemon-tree . . . . .	.703		

*Specific Gravities of Stones, Earths, &c.*

Alabaster, yellow . . . . .	2.699	Granite, Bretagne, yellowish . . . . .	2.619
Ambergris . . . . .	.926	Grindstone . . . . .	2.143
Amianthus, long . . . . .	.909	Gypsum, opaque . . . . .	2.168
short . . . . .	2.313	semi-transparent . . . . .	2.306
Asbestos, ripe . . . . .	2.578	Hone, white, razor . . . . .	2.876
starry . . . . .	3.073	Jet, a bituminous substance . . . . .	1.259
Borax . . . . .	1.714	Lime-stone, green . . . . .	3.182
Brick . . . . .	2.000	white fluor . . . . .	3.156
Chalk, British . . . . .	2.784	compact . . . . .	2.720
Coal, Cannel . . . . .	1.270	Manganese . . . . .	7.000
Newcastle . . . . .	1.270	Marble, Biscayan, black . . . . .	2.695
Staffordshire . . . . .	1.240	Brocatelle . . . . .	2.650
Scotch . . . . .	1.300	Carrara, white . . . . .	2.717
Cutler's stone . . . . .	2.111	Egyptian, green . . . . .	2.668
Emery . . . . .	4.000	Italian, violet . . . . .	2.858
Flint, black . . . . .	2.582	red . . . . .	2.724
white . . . . .	2.594	Porcelain, China . . . . .	2.385
Glass, flint . . . . .	2.933	Porphyry, red . . . . .	2.765
bottle . . . . .	2.732	green . . . . .	2.676
green . . . . .	2.642	Salt . . . . .	2.130
Leith, crystal . . . . .	3.189	Serpentine, opaque, green, . . . . .	
Granite, Aberdeen, blue kind . . . . .	2.625	Italian . . . . .	2.430
Cornish . . . . .	2.662	Slate, common . . . . .	2.672
Egyptian, red . . . . .	2.654	Stalactite, opaque . . . . .	2.478
beautiful red . . . . .	2.761	Stone, Bristol . . . . .	2.510
Girardinor . . . . .	2.716	Portland . . . . .	2.570
violet, of Gyromagny . . . . .	2.685	Pumice . . . . .	.915
Dauphiny, red . . . . .	2.643	Purbeck . . . . .	2.601
" green . . . . .	2.684	rag . . . . .	2.470
" radiated . . . . .	2.668	Sulphur, native . . . . .	2.033
Semur, red . . . . .	2.638	melted . . . . .	1.991
Bretagne, grey . . . . .	2.738	Talc, Muscovy . . . . .	2.792

*Specific Gravities of Liquids.*

	Sp. Grav.		Sp. Grav.
Acetic acid . . . . .	1.007	Oil of linseed . . . . .	.940
Alcohol, commercial . . . . .	.837	olives . . . . .	.915
highly rectified . . . . .	.829	poppies . . . . .	.924
Ammonia, liquid . . . . .	.897	rape-seed . . . . .	.919
muriate of . . . . .	1.453	turpentine, essential . . . . .	.870
Beer, pale . . . . .	1.023	whales . . . . .	.923
brown . . . . .	1.034	Spirits of wine, commercial . . . . .	.837
Benzoic acid . . . . .	1.018	highly rectified . . . . .	.829
Cyder . . . . .	1.018	Sulphuric acid . . . . .	1.811
Ether, acetic . . . . .	.866	highly concentrated . . . . .	2.125
muriatic . . . . .	.730	Turpentine, liquid . . . . .	.991
nitric . . . . .	.909	Vinegar, distilled . . . . .	1.010
sulphuric . . . . .	.739	Water, rain . . . . .	1.000
Fluoric acid . . . . .	1.500	distilled . . . . .	1.000
Formic acid . . . . .	.994	sea . . . . .	1.026
Milk of Cows . . . . .	1.032	Wine, Burgundy . . . . .	.992
Muriatic acid . . . . .	1.194	Bordeaux . . . . .	.994
Nitric acid . . . . .	1.271	Champagne, white . . . . .	.998
highly concentrated . . . . .	1.583	Canary . . . . .	1.033
Oil of almonds, sweet . . . . .	.917	Constance . . . . .	1.082
cloves, essential . . . . .	1.036	Madeira . . . . .	1.038
cinnamon, essential . . . . .	1.044	Malaga . . . . .	1.022
filberts . . . . .	.916	Port . . . . .	.997
hemp-seed . . . . .	.926	Tokay . . . . .	1.054
lavender, essential . . . . .	.894		

*Specific Gravities of Resins, Gums, Animal Substances, &c.*

Aloes, socotrine . . . . .	1.380	Gunpowder, in a loose heap . . . . .	.836
Ambergris . . . . .	.926	shaken . . . . .	.932
Assafoetida . . . . .	1.328	solid . . . . .	1.745
Bark, Peruvian . . . . .	.785	Honey . . . . .	1.450
Butter . . . . .	.942	Indigo . . . . .	.769
Camphor . . . . .	.989	Ivory . . . . .	1.826
Copal, Chinese . . . . .	1.063	Lard . . . . .	.948
Fat, beef . . . . .	.923	Madder-root . . . . .	.765
mutton . . . . .	.924	Mastic . . . . .	1.074
veal . . . . .	.934	Myrrh . . . . .	1.360
hog's . . . . .	.967	Olibanum . . . . .	1.173
Galbanum . . . . .	1.212	Opium . . . . .	1.336
Gamboge . . . . .	1.222	Spermaceti . . . . .	.943
Gum Ammoniac . . . . .	1.207	Sugar, white . . . . .	1.606
Arabic . . . . .	1.452	Tallow . . . . .	.942
Scammony of Aleppo . . . . .	1.235	Wax of bees, white . . . . .	.969
" of Smyrna . . . . .	1.274	yellow . . . . .	.965
tragacanth . . . . .	1.316	Shoemakers' . . . . .	.897

*Gases.*

In the following Table, the specific gravities of the principal gases will be given as they correspond with the specific gravity of atmospheric air, which is supposed to be about 1.000.

Atmospheric, or common air . . . . .	1.000	Carbonic acid . . . . .	1.520
Ammoniacal gas . . . . .	.500	oxide . . . . .	.960
Arsenical hydrogen gas . . . . .	.529	Carburetted hydrogen . . . . .	.491
Azote . . . . .	.969	Chlorine . . . . .	.470

	Sp. Grav.		Sp. Crav.
Chloro-carbonic gas . . . . .	3.389	Oxygen, mean . . . . .	1.044
Chloro-cyanic vapour . . . . .	2.111	Phosphuretted hydrogen . . . . .	.870
Cyrogen . . . . .	1.806	Steam . . . . .	.690
Euchlorine . . . . .	2.409	Sulphuretted hydrogen . . . . .	1.777
Fluoboracic . . . . .	2.371	Sulphurous acid . . . . .	2.193
Fluosilicic acid gas . . . . .	3.574	Vapour of Alcohol . . . . .	2.100
Hydrogen . . . . .	.074	absolute alcohol . . . . .	1.613
Hydriodic acid gas . . . . .	4.443	hydriotic ether . . . . .	5.475
Hydrocyanic vapour . . . . .	.948	iodine . . . . .	8.620
Muriatic acid gas . . . . .	1.278	muriatic ether . . . . .	2.219
Nitrous gas . . . . .	1.094	oil of turpentine . . . . .	5.013
acid gas . . . . .	2.427	sulphuret of carbon . . . . .	2.645
oxide . . . . .	1.614	sulphuric ether . . . . .	2.586

In concluding, it may be necessary to remark, that all bodies expand by heat and contract by cooling; but the contraction and expansion, by the same change of temperature, is very different in different bodies. Water, when heated from 60 to 100 degrees, increases its volume nearly one sixty-seventh of its bulk; mercury, one two-hundred and forty-third part; and many substances much less. It is therefore proper, in ascertaining the specific gravities of bodies, to note particularly the temperature.

**SPECTACLES.** An optical instrument consisting of two lenses set in a light frame, the extremities of which are made elastic, so as to retain, by a slight pressure against the sides of the head, the instrument in its place, which is supported upon the nose of the wearer. The use of spectacles is to counteract some defects in the organs of vision; and as these differ in their nature, the lenses vary in their properties. Those with convex lenses serve to counteract the effects arising from the too great flatness of the eye, by giving the rays of light a degree of convergency sufficient to make them meet exactly at the retina, and are, therefore, generally proper for elderly persons. On the contrary, short-sighted people use concave lenses, to prevent the rays from converging so suddenly,—because the eyes of such persons being too round and protuberant, give too great a convergency to the rays, and cause them to meet before they reach the retina, which defect is remedied by glass of a suitable concavity.

**SPERMACETI.** A substance obtained from the oil found in the head of several species of whale, but chiefly from the *physeter macrocephalus*. Though analogous to fat and wax, it differs from them in several properties. It is of a flaky texture—soft, white, and brilliant; melts at 113°; and by raising the heat may be volatilized with little change, though by repeated distillation it is decomposed. It burns with a clear flame. A property distinguishing it from fat is that of solubility in alcohol and ether, though it is but sparingly soluble in the former. It dissolves more rapidly and abundantly in warm ether, from which it precipitates when cool: oil of turpentine acts upon it in a similar manner. Spermaceti is found in a large triangular trunk, four or five feet deep, and ten or twelve long, filling almost the whole cavity of the head, and seeming to be entirely different from the proper brain of the animal. The oil is separated from it by dripping. In this state it has a yellow, unctuous appearance, and is brought to England in barrels. An ordinary sized whale, it is said, will yield upwards of twelve large barrels of crude spermaceti. The mode of purifying it in the large way is as follows:—the mass is put into hair or woollen bags, and pressed between plates of iron, in a screw-press, until it becomes hard and brittle. It is then broken into pieces, and thrown into boiling water, where it melts; and the impurities which rise to the surface, or sink to the bottom, are skimmed off or separated from it. After being cooled, and separated from the water, it is put into fresh water in a large boiler, and a weak ley of the potash of commerce added to it by degrees. This part of the process is thrice repeated, after which the whole is poured into coolers, when the spermaceti concretes into a white semi-transparent mass, which, on being cut into small pieces, assumes

the flaky appearance which it has in the shops. Some adulterate it with wax; but the deceit is discovered, either by the smell of the wax, or by the dulness of the colour. Some also sell a preparation of oil taken from the tail of the whale, instead of that from the brain; but this kind turns yellow as soon as exposed to the air. Indeed, it is apt, in general, to grow yellowish, and to contract a rancid, fishy smell, if not carefully secured from the air. The more perfectly it has been purified at first, the less susceptible it is of these alterations; and after it has been changed, it may be rendered white and sweet again by steeping it afresh in a ley of alkaline salt and quicklime. It melts in a small degree of heat, and congeals again as it cools.

The great use of spermaceti is for making candles, and it is also employed in medicine. Spermaceti candles are of modern manufacture: they are made smooth, with a fine gloss, free from rings and scars, superior to the finest wax candles in colour and lustre; and, when genuine, leave no spot or stain on the finest silk, cloth, or linen.

**SPHERE.** A solid contained under one uniform round surface, such as would be formed by the revolution of a circle about the diameter thereof.

**SPHEROID.** A solid body approaching the figure of a sphere, though not exactly round, but having one of its diameters longer than the other.

**SPINDLE.** A term synonymous with axis. In machinery where several axes occur, it is usual to denominate the subordinate or smaller axes spindles, as in cotton-spinning, &c.

**SPINET.** A musical instrument of the piano-forte kind. The latter, by its improved tones and construction, has superseded the manufacture, and almost wholly banished the use of the former. See **PIANO-FORTE.**

**SPINNING.** The art of combining animal or vegetable fibres into threads, by twisting them together, as in cotton, silk, wool, flax, hemp, &c. See those articles.

**SPONGE.** A marine production of a remarkably porous and absorbent nature. Its property of readily imbibing almost as great a volume of water as its own bulk, and as readily parting with it by compression, renders it of great utility. The best is of a light colour, free from stones and other impurities, very soft and elastic, and the pores or holes small. It is chiefly obtained from the Mediterranean, about the shores of Turkey and the Archipelago, where it grows upon the rocks at considerable depths under water. To bleach sponge and render it white, it is soaked repeatedly in fresh water, changing the fluid several times a day; and at the end of five or six days it will be ready for bleaching. If the sponge contains pieces of shells, chalk, &c., which cannot be extracted without tearing it, the sponge must be soaked for twenty-four hours in muriatic acid, diluted in twenty times as much water, which will cause an effervescence to take place, and carbonic acid to be liberated, when the shells and chalk will be dissolved. After this the sponge must be carefully washed in fresh water, and then immersed for seven or eight days in a weak solution of sulphuric acid (specific gravity 1.024), occasionally pressing it out dry. After it has again been perfectly washed and cleaned, it may be sprinkled with a little rose-water, to give it a pleasant smell.

**STARCH.** A well-known substance extracted from wheaten flour, by washing it in water. All farinaceous seeds afford this substance in a greater or less degree; but it is most easily obtained from the flour of wheat, by moistening any quantity with a little water, and kneading it with the hand into a tough paste; this being washed with water, by letting fall upon it a very slender stream, the water will be rendered turbid as it runs off, in consequence of the fecula or starch which it extracts from the flour, and which will subside when the water is allowed to stand at rest. The starch so obtained, when dried in the sun, or by a stove, is usually concreted into small masses, which have a fine white colour, scarcely any smell, and very little taste. If kept dry, starch in this state continues a long time uninjured, although exposed to the air. The inferior and refuse wheat is usually employed for manufacturing common starch; but when the finest starch is required, good grain must be used. This, being well cleaned, and sometimes coarsely bruised, is put into wooden vessels

full of water, to ferment: to assist the fermentation, the vessels are exposed to the greatest heat of the sun, and the water is changed twice a day, during eight or twelve days, according to the season. When the grain bursts easily under the finger, and gives out a milky white liquor when squeezed, it is judged to be sufficiently softened and fermented. In this state the grains are taken out of the water by a sieve, and put into a canvass sack, and the husks are separated and rubbed off by beating and rubbing the sack upon a plank: the sack is then put into a tub filled with cold water, and trodden or beaten till the water becomes milky and turbid, from the starch which it takes up from the grain. A scum sometimes swims upon the surface of the water, which must be carefully removed; the water is then run off through a fine sieve into a settling vessel, and fresh water is poured upon the grains, two or three times, till it will not extract any more starch, or become coloured by the grain. The water in the settling vessels, being left at rest, precipitates the starch, which is held suspended; and to get rid of the saccharine matter, which was also dissolved by the water, the vessels are exposed to the sun, which soon produces the acetous fermentation, and takes up such matter as renders the starch more pure and white. When the water becomes completely sour, it is poured gently off from the starch, which is washed several times afterwards with clean water, and at last is placed to drain upon linen cloths, supported by hurdles, and the water drips through, leaving the starch upon the cloths, in which it is pressed and wrung, to extract as much as possible of the water; and the remainder is evaporated by cutting the starch into pieces, which are laid up in airy places, upon a floor of plaster, or of slightly burnt bricks, until it becomes completely dried from all moisture, partly from the access of warm air, and partly by the floor imbibing the moisture. In winter time, the heat of a stove must be employed to effect the drying. Lastly, the pieces of starch are scraped to remove the outside crust, which makes inferior starch, and these pieces are broken into smaller pieces for sale.

**STEAM.** The term generally employed to designate water in its elastic form, at or above the temperature of  $212^{\circ}$ . It is at present applied to many economical purposes, as well as in various manufactures, independent of its important office in the steam-engine. In order to make water boil, the fire must be applied to the bottom or sides of the vessel which contains it: if the heat be applied at the surface of the water, it will waste away without boiling, because the superficial particles, by imbibing the heat necessary to render them elastic, fly off without agitating the rest; but when applied to the lower surface of the water, the bubbles which are formed at the bottom rise, and give off their heat to the incumbent mass, and then disappear by collapsing: the distances which they reach before collapsing increase as the water continues to warm further up the mass, till it breaks out into boiling on the surface. If the handle of a tea-kettle be grasped with the hand, a tremor will be felt for some little time before boiling, arising from the little succussions which are produced by the collapsing of the bubbles of vapour. This is much more violent, and is really a remarkable phenomenon, if we suddenly plunge a lump of red hot iron into a vessel of cold water, when, if the hand be applied to the side of the vessel, a most violent tremor is felt, and sometimes strong thumps; these arise from the collapsing of very large bubbles. The great resemblance of this tremor to the feeling experienced during the shock of an earthquake has led many to suppose that these last are produced in the same way; and the hypothesis is by no means unfeasible.

The following propositions have been generally assumed by certain authorities as correct data:—

1. A cubic inch of water forms a cubic foot of steam, when its elasticity is equal to 30 inches of mercury.

2. One pound of Newcastle coal will convert seven pounds of boiling water into steam.

3. The time required to convert a given quantity of boiling water into steam is six times that required to raise it from the freezing to the boiling point, or from  $32^{\circ}$  to  $212^{\circ}$ , supposing the supply of heat to be uniform.



4. When a quantity of water is exposed to a given temperature, the quantity of steam formed in a given time will be as the surface, all other things being equal. The quantity will also be jointly as the force of vapour answering to each degree of heat, and the surface. The depth of water evaporated in a given time will be as the force of vapour, whatever the surface, if the mass be uniformly of the same temperature. When the force of vapour is 30 inches, and the temperature at  $212^{\circ}$ , this degree being just preserved only, the depth evaporated is 1.3 inch in one hour.

5. When a quantity of water is raised to the boiling point, or  $212^{\circ}$ , it requires as much heat to give it the elastic form as would raise the same water  $900^{\circ}$  higher if its volume were not changed by the heat; that is, if it could be prevented from expanding, its temperature would become  $1112^{\circ}$  with the same quantity of caloric; thus, agreeably to fact 3, the heat required to convert water of  $212^{\circ}$  in to steam is six times that required to raise the temperature from  $32^{\circ}$  to  $212^{\circ}$ . See also STEAM-ENGINE, *power of*.

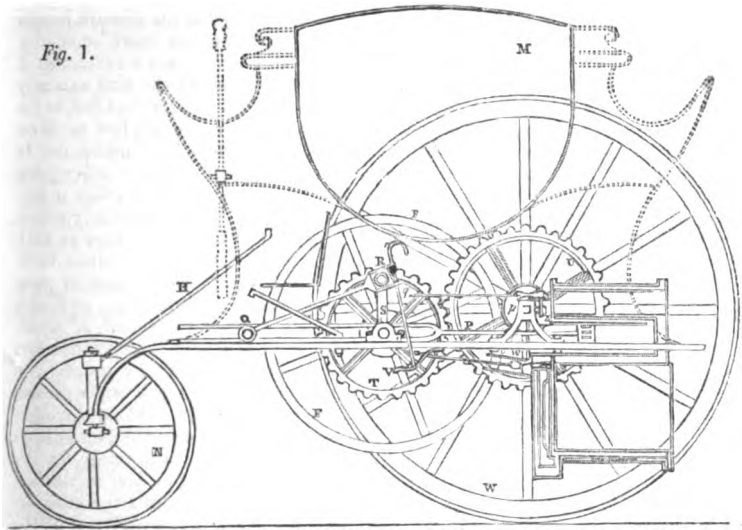
STEAM CARRIAGES.—Under this designation is to be understood all kinds of locomotive vehicles, propelled on the common roads, by other than animal force.

In the case of steam carriages used upon *rail-roads*, the structure of one is so dependent upon the other, that the former may be regarded as the *moving*, and the latter the stationary part, of the same machine. Whether the distinction thus attempted to be drawn is not in some degree applicable to both classes of locomotives, might be disputed; but there are other marked differences between them, which have induced us to treat them separately. The common road locomotives require to *perfect* them a higher degree of mechanical skill than those on the rail; because they have not, like the latter, a level and unyielding surface to roll upon, but one that is full of asperities, and easily penetrable, hence increasing in a great degree the difficulties of construction. The former, likewise, now belong to a history of the past; while the latter form the glories of the present day. We therefore refer the reader to the Article RAILWAY, for all locomotives that are designed for that species of way.

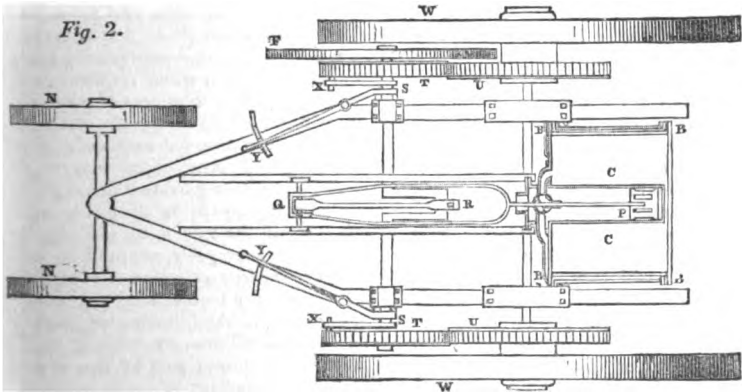
The merit of the first suggestion of steam carriages has been attributed to various individuals; but the probability is, that the idea of applying the steam engine for the purpose of locomotion is coeval almost with its first invention. Thus Savery from having considered its possibility, and Dr. Robison for having suggested it to Watt, have by some been regarded as the inventors. Mr. Watt, however, never built a steam engine; and it is said that he retained up to the period of his death, the most rooted prejudices against the use of *high steam*. Indeed, he says himself, "I soon relinquished the idea of constructing an engine on this principle, from being sensible it would be liable to some of the objections against Savery's engines, viz. the danger of bursting the boiler, and that a great part of the power of the steam would be lost, because no vacuum was formed to assist the descent of the piston." It was, however, the sagacity of two Cornish engineers, Trevithick and Vivian, which enabled them to perceive in the excessive force exerted by high steam, (and which alarmed Watt,) that very power which was indispensable to the propulsion of locomotive carriages; as it dispensed with the use of a condenser, and all its cumbrous appendages.

Previous to the year 1802, animal power was the only one known or in use for the moving of carriages; at that period, the above mentioned engineers obtained a patent for an improved steam engine, which was the first of the high pressure kind, and is thus characterized by the eloquent Mickleham. "It exhibits in construction the most beautiful simplicity of parts, the most sagacious selection of appropriate forms, their most convenient and effective arrangement and connexion; uniting strength with elegance; the necessary solidity with the greatest portability; possessing unlimited power with a wonderful pliancy to accommodate it to a varying resistance: it may indeed be called "THE STEAM ENGINE." The specification of the patent, after describing this engine, proceeds to show its application, "to give motion to wheel carriages of every description," by suitable drawings and explanations. From a copy of

that document we derive the following account of the first steam carriage which was constructed.



TREVITHICK AND VIVIAN'S STEAM CARRIAGE.—PATENT 1802.



*Fig. 1.* is a vertical section, and *Fig. 2.* a plan, showing the principal arrangements of the first steam carriage. "At *B B*, is the case, having therein the boiler, with its fire place and flues. At *P Q*, is the piston rod, forked to admit the end of the crank *R*; the said rod drives a cross piece at *Q* backward and forward between guides; and this cross-piece, by means of the bar *Q R*, gives motion to the crank with its fly *F*, and to two wheels *T* upon the crank axis, which lock into two correspondent wheels *U* upon the naves of the large wheels of the carriage itself. The wheels *T* are fixed upon round sockets, and receive their motion from a striking box or bar *S X*, which acts upon a pin in each wheel; *S Y* are two handles, by means of which either of the striking boxes *S X* can be thrown out of gear, and the correspondent wheel *W* by that means dis-

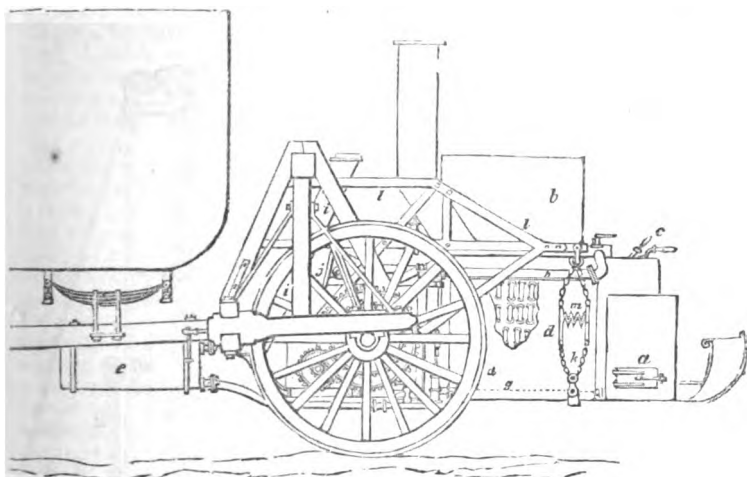
connected with the first mover, for the purpose of turning short, or *admitting a backward motion of that wheel when required*; but either of the wheels *w*, in case of turning, can be allowed considerably to overrun the other without throwing six out of gear, because the pin can go very nearly round in the forward motion before it will meet with any obstruction. The wheels *u* are most commonly fixed upon the naves of the carriage-wheels *w*, by which means a revolution of the axis itself becomes unnecessary, and the outer ends of the said axis may consequently be set to any obliquity, and the other part fixed or bended, as the objects of taste or utility may demand. *The fore-wheels are applied to direct the carriage by means of a lever n*; and there is a check lever which can be applied to the fly, in order to moderate the velocity of progression when going down hill. In the vertical section is shown a springing lever, having a tendency to fly forward. Two levers of this kind are duly and similarly placed near the middle of the carriage, and each of them is alternately thrown back by a short bearing lever upon the crank axis, which sends it home into a catch at the end, and afterwards releases it when the bearing lever comes to press upon *v*, in which case the springing lever flies back. A cross bar, or double handle is fixed upon the upright axis of the cock, from each end of which said cross bar proceeds a rod *p q*, which is attached to a stud *q*, that forms part of the spring lever. This stud has a certain length of play, by means of a long hole or groove in the bar, so that when the springing lever is pressed up, the stud slides in the groove without giving motion to *p*. When the other springing lever is disengaged, it draws the opposite end of the handle, and causes *p* to draw the long hole at *q* up to its bearing against the stud, ready for the letting off of that first-mentioned springing lever. When this last mentioned lever comes to be disengaged, it suddenly draws *p* back, and turns the cock one quarter turn, and performs the like office of placing the horizontal rod of the other extremity of the handle ready for action by its own springing-lever. *These alternations perform the opening and shutting of the cock*, and to one of the springing levers is fixed a small force-pump *w*, which draws hot water from the case by the quick back-stroke, and forces it into the boiler by the stronger and more gradual pressure of a lever on the crank axis. It is also to be noticed that in certain cases we make the external periphery of the wheels *w* uneven, by projecting heads of nails or bolts, or cross grooves, or fittings to railroads, when required; and that in cases of hard pull we cause a lever, bolt, or claw, to project through the rim of one or both of the said wheels, so as to take hold of the ground; but that in general the ordinary structure or figure of the external surface of these wheels will be found to answer the intended purpose. And, moreover, we do observe and declare, that the power of the engine, with regard to its convenient application to the carriage, may be varied, by changing the relative velocity of rotation of the wheels *w* compared with that of the axis *s*, by shifting the gears or toothed wheels for others of different sizes, properly adapted to each other in various ways, which will readily be adopted by any person of competent skill in machinery. The body of the carriage *x* may be made of any convenient size or figure, according to its intended uses. And, lastly, we do occasionally use bellows to excite the fire, and the said bellows are worked by the piston-rod or crank, and may be fixed in any situation or part of the several engines herein described, as may be found most convenient."

A carriage was built soon after the grant according to the construction above given, and exercised before the public for a considerable time in the neighbourhood of the present site of Euston Square, London. Succeeding patentees, it will be observed, have availed themselves of the judicious arrangement of these ingenious projectors.

Such was the indifference of the public to inventions of the kind, that nineteen years elapsed before another steam carriage for the common road was brought out, which was the subject of a patent granted to Mr. Julius Griffith in 1821; and this carriage, we are informed, was chiefly designed by foreigners.

At *a* is the furnace, supplied with fuel from a receptacle *b*. At *c* are two handles, one to open the feeding door, and the other to operate upon a damper. The boiler is at *d* in a double case packed with non-conducting materials. The

boiler consists of tiers of horizontal tubes. Connected by bolts and straps to the frame of the carriage, is a reservoir of water *e*, which is drawn out by a force-pump at *f*, and by the return stroke injected into a pipe *g* at the bottom of the



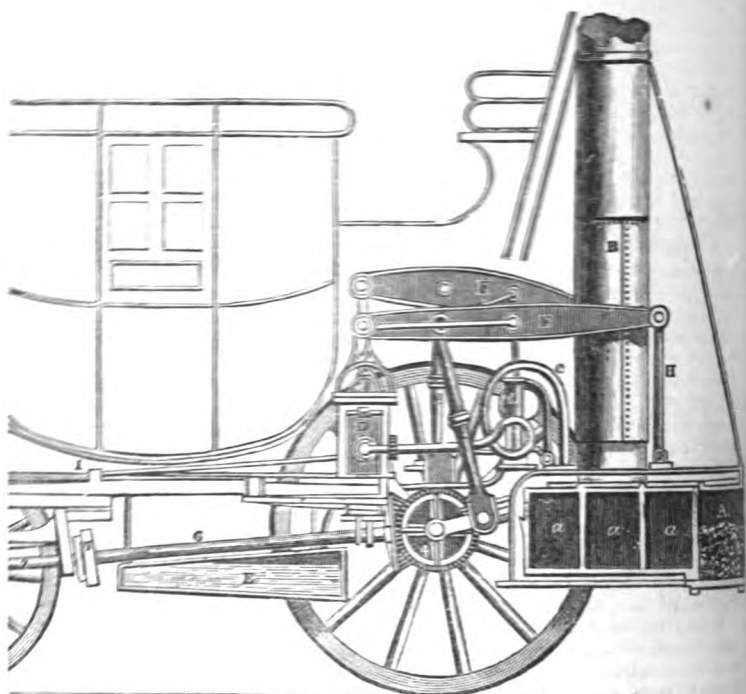
Griffith's Steam Carriage.—Patent 1821.

boiler, whence it is distributed into the lowermost range of tubes, and from these to the next above, the uppermost row being employed as steam reservoirs, and receiving the waste heat as it passes to the chimney, so as to increase the elastic force of the vapour before it proceeds along the steam pipe *h* to the engines, whence, after having given motion to the pistons, it is conducted by a pipe into the condenser *i*, which consists of a number of flattened thin metal tubes, exposed to the cooling influence of the air. The power of the engines is communicated from the piston rods to the running wheels of the carriage through the means of sweep-rods, (one of which is brought into view at *j*), the lower ends of which are provided with driving pinions and detents, which operate upon toothed gear fixed to the hind carriage wheel axle. The object of this mechanism, (which is of foreign invention, and denominated an Artzberger,) is to keep the driving pinions always in gear with the toothed wheels, however the engine and other machinery may vibrate, or the wheels be jolted upon uneven ground. In order that the engines and steam apparatus may not suffer from the concussions of the latter, they are suspended by slings at *k* to a strong iron framing *l*, and to give the suspending chains some degree of elasticity, stout helical springs are introduced between them, as shown at *m*.

The guiding of the carriage is effected by means of levers which turn round the axles of the fore wheels, so as to present the latter in the line of direction required. The axles are supported in a vertical frame, which is made to turn horizontally, by means of a guide wheel, on the top of a spindle, the lower extremity of which carries a pinion that takes into an internal toothed wheel at *p*.

We are not aware that Mr. Griffith's carriage ever made any public demonstrations of its working powers; but Mr. A. Gordon states that the chief difficulty which Mr. Griffith had to contend with, was the liability of having all the water blown out of the tubes, by the pressure of the steam on the lower part; no provision having been made for allowing the water to return, or for maintaining an equilibrium of pressure. Notwithstanding the failure of this attempt,

it was rapidly succeeded by many other projectors in this line. The next in order of date was patented by Messrs. Burstall and Hill in 1824. Annexed is a cut representing an elevation of the machine, the fore part of the carriage being omitted as not being necessary to the explanation, and as effecting a saving of space.



BURSTALL AND HILL'S STEAM CARRIAGE.—PATENT 1824.

"A is the place for fuel, and *a a a* are parts of the flue, as seen in section, the top being formed into a number of shallow receptacles for water in a state of being converted into steam. B is the chimney; at D are two cylinders, one behind the other, which are fitted up with pistons and valves in the usual way, for the alternate action of steam above and below the pistons. The boiler is suspended on springs; and the steam is conveyed from it to the engines, through the helical pipe *c*, which has that form given to it to allow the vibration of the boiler, without injury to the steam joints. E is the cistern containing water for one stage, say 50 to 80 gallons, and made to sustain a pressure of about 60 pounds to the square inch. At *e* are one or more air-pumps, which are worked by the beams F E of the engines, and are used to force air into the water vessel, that its pressure may drive out, by a convenient pipe, the water into the boiler, as it may be required. The two beams are connected at one end with the piston rods, and at the other with the rocking standards H H; *g g* are connecting rods attached to two cranks, giving a continued rotatory motion to the wheels, without the necessity of a fly-wheel. The four coach wheels are attached to the axles nearly as in common coaches, except that there is a ratchet wheel formed upon the back part of the nave, with a box wedged into the axle, containing a spring pall, causing the wheels to be impelled when the axle

revolves, and at the same time allowing the outer wheel, when the carriage describes a curve, to travel faster than the inner one, and still be ready to receive the impulse of the engine as soon as it comes to a straight course.

"The patentees have another method of performing the same operation, with the further advantage of backing the coach when the engines are backed. In this plan, the naves are cast with a recess in the middle, in which is a double bevelled clutch, the inside of the nave being formed to correspond. The clutches are simultaneously acted upon by connecting levers, and springs, and which, according as they are forced to the right or left, will enable the carriage to be moved forward or backward. To the fore nave are fixed two cylindrical metal rings, round which are two friction bands, to be tightened by a lever convenient for the foot of the conductor, and which will readily retard or stop the coach when descending hills. *K* is the seat of the conductor, with the steering wheel *L* in the front, which is fastened on the small upright shaft 1, and turns the two bevel pinions 2, and the shaft 3, with its small pinion 4, which, working into a segmental rack on the fore carriage, places the two axles at any required angle, the centre of motion being the perch-pin *I*."

The patentees built a steam carriage upon the foregoing plan, but with numerous alterations and modifications. Their success in demonstration was but partial. Like other locomotionists who followed them, something was always requiring to be altered, to overcome new difficulties introduced by previous improvements; but they had the good sense to retire from the undertaking without very heavy pecuniary loss, and with undiminished reputation as machinists; the problem not having been solved, *satisfactorily*, by any succeeding inventors.

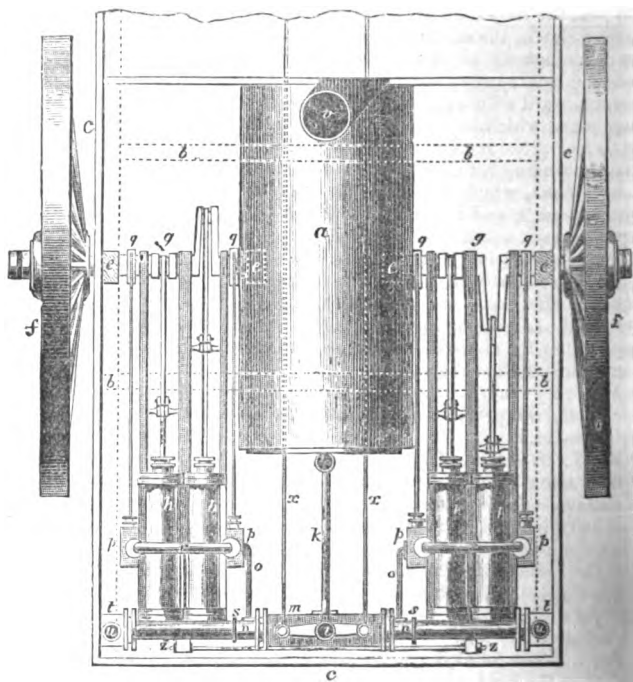
Mr. W. H. James, of Birmingham, gave the subject of steam carriages much studious attention for several years, in the course of which, and through the aid of Sir James C. Anderson, he constructed several in succession. The first of them acted as well, or nearly so, as those which followed.

Mr. James caused the engines and their frame-work to vibrate altogether upon the crank shafts as a centre, and connected these engines to the boiler and exit passages, by means of hollow axles moving in stuffing boxes, which, together with the body of the carriage, were suspended upon springs bolted to the axletrees.

Fig. 1, in the following cut, exhibits a plan of the machinery of a carriage, as applied to the hind wheels. At *a* is the boiler; which consisted of a series of annular tubes of equal capacity and diameter, placed side by side, and bolted together, so as to form by their union a long cylindrical boiler, as shown in the figure. A full description of this generating apparatus having been already given under the article *BOILER*, we shall not here enlarge upon it. The frame *b* has four vertical supports *e e e e* connected to it, and from these beams are extended over the boiler, which is suspended to them; and they also carry by suitable bearings the body of the vehicle, which it is unnecessary to explain.

The axles of the running wheels *f f* are connected in one piece with each of the crank shafts *g g*, by which one wheel is made to revolve independently of the other. Each of these engines has two cylinders *h h*, which operate by their piston rods upon the cranks; to these separate engines steam is applied from the boiler *a a*, by means of the pipe *k*, which enters at the stop-cock *l* into the steam-box *m*; from this box the steam passes into the pipes *n n*, which move steam-tight through stuffing-boxes; from thence the steam proceeds through the pipes *o o o* to the slide boxes *p p p*, the slides being worked by eccentrics *q q q*, on the crank shafts, in the usual manner, and thence to the cylinders. The exhaustion pipes *r r* lead into hollow axles *n n*, in which there are partitions *s s*, to separate the steam from the exit passages, which pass through the said hollow axles to the boxes *t t*, from which there are pipes *u u* leading to the chimney *v*, where it is thrown off to increase the draught, and combustion of the fuel. The rods *x x* are attached to the fore axle of the running wheels, and also to the two handles of the cock *l*, so that the fore axle and the cock move simultaneously, and parallel to each other; *z z* represent part of the frame-work extended, for

tying the engine together by means of a bolt, and so as to allow the body of the carriage to have a slight lateral motion upon its springs, independently of the engines, by means of the hollow axles sliding longitudinally through the stuffing-boxes.



### W. II. JAMES'S STEAM CARRIAGE.—PATENT 1824.

In 1832 Mr. James took out another patent, the chief features in which were a high pressure boiler of a novel description; being formed of a horizontal tier of cast-iron plates ingeniously cast with tubular cavities in the body of the metal, and throughout its area. These cavities hold the water to be vaporized, which is constantly made to flow throughout the tier, by a hydraulic apparatus, which the inventor denominates a "heart-pump." The fire operates upon the entire bottom surface of each water-plate, and the steam is collected in the highest plate, to which, in addition to the usual appendages of a steam carriage, is a steam pipe leading to a trumpet, which is sounded by the motion of a lever operating upon a valve at the induction orifice.

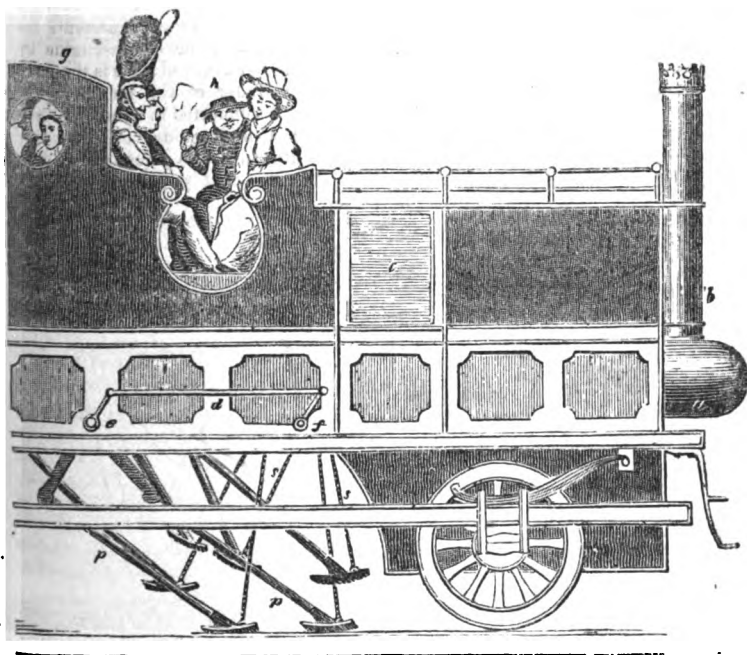
The performances of Messrs. James & Co.'s carriages were not much dissimilar to those of other locomotionists of like extent of experience. The practicability of the scheme in a mechanical point of view, we had many demonstrations of; and on one occasion we were propelled at the rate of fifteen miles an hour for several miles together. But the undertaking was (commercially speaking) unsuccessful, and was therefore discontinued.

In 1824 the late Mr. David Gordon obtained a patent for steam carriages to run on common roads.

Mr. David Gordon's carriage ran upon three wheels; one in front to steer by, and two behind to bear the chief weight. Each of the wheels had a separate

axle, the ends of which had their bearings upon parallel bars, the wheels rolling in a perpendicular position.

In the fore part of the carriage were placed the steam engines, consisting of two brass cylinders, in a horizontal position, but vibrating upon trunnions: the piston rods of these engines gave motion to an eight-throw crank, two in the middle for the cylinders, and three on each side, to which were attached the propellers; by the revolution of the crank, these propellers or legs were successively forced outwards, with the feet of each against the ground in a backward direction, and were immediately afterwards lifted from the ground by the revolution of another crank, parallel to the former, and situated at a proper distance from it on the same frame. To the lower ends of these propelling rods were attached the feet, of the form of segments of circles, and made on their under side like a short and very stiff brush of whale-bone, supported by intermixed iron teeth. These feet pressed against the ground in regular succession, by a kind of rolling, circular motion, without digging it up. The guide had the power of lifting these legs off the ground at pleasure, so that, in going down hill, when the gravity was sufficient for propulsion, nothing but a brake was put into requisition to retard the motion, if necessary. If the carriage was proceeding upon a level, the lifting of the propellers was equivalent to the subtraction of the power, and soon brought it to a stoppage; and in making turns in a road, the guide had only to lift the propellers on one side of the carriage, and allow the others to operate alone, until the curve was traversed.



DAVID GORDON'S STEAM CARRIAGE.—PATENT 1824.

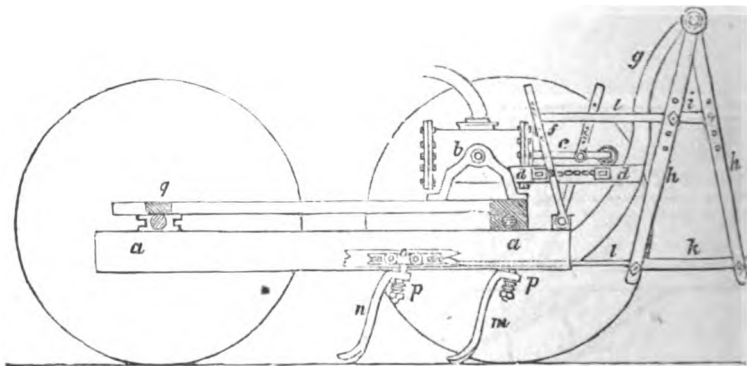
The above engraving represents a side elevation of the machine; the front of the carriage being cut off as useless to our object, and as occupying valuable space. At *a* is the end of the boiler; *b* the flue; *c* an apartment for the



engineer to attend the fire and regulate the machinery, which apartment contains a store of water, coke, &c. ; *d* external connecting rod ( one on each side of the carriage ), by which the driving cranks of the propellers actuate the small lifting cranks within the carriage ; *e* being the axis of the driving cranks, and *f* the axis of the lifting cranks ; *p p* are the propellers ; *ss* straps by which the propellers are lifted from the ground by the alternations of the crank.

It was in the year 1825, that Mr. Goldsworthy Gurney, a medical gentleman of London, commenced his career in locomotion ; and being liberally supported by capitalists, he built a number of steam carriages ; which during several years were occasionally brought out of the factory, and experimented with on the public roads ; but without attaining that degree of success, in an economical point of view, which the public were at first led to believe had been effected. The first attempt made by Mr. Gurney was, properly, that of producing a steam generator of superior efficacy, which our readers will find fully described and illustrated in the **BOILER**. The specification of his patent is thus reported in the London Journal of Arts and Sciences.

“ The mode of propelling carriages on roads and railways, proposed by the patentee, is by the agency of moving legs, or crutches, striking out under the carriage, the lower ends of which legs are intended to bear against the ground as a resistance, and, being forced backwards by the power of machinery, cause the carriage to move forward in the opposite direction. Similar contrivances to this have been repeatedly suggested. The patentee, therefore, is to be considered as merely adopting this plan as one that he considers most convenient ; and claims as his invention *simply the guide rollers* attached to the legs, upon which the carriage moves forward. The annexed figure represents the side of the carriage running upon ordinary wheels, with the steam-engine by which its propelling legs and other mechanism are to be moved ; *a a* is the perch or main beam of the carriage ; *b* the working cylinder of the steam-engine, which in this instance lies nearly horizontal, and is supported in standards upon pivots ; *c* is the piston rod of the engine, with a small guide roller running upon the stationary block *d*. The piston rod is attached by a joint to the vibrating lever *e*, from which lever a chain extends over small pulleys, let into the

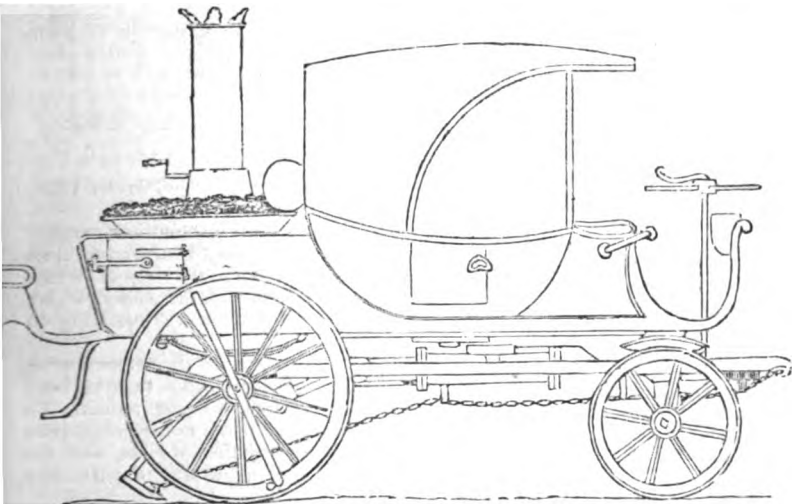


**GOLDSWORTHY GURNEY'S STEAM CARRIAGE.—FIRST PATENT 1825.**

blocks *d*, and its ends are made fast to the other vibrating lever *f* ; consequently, these two levers acquire reciprocating motions from the action of the piston rod. At the extremity of the crane's neck *g*, the two oscillating levers *h h* are suspended, and these being respectively attached by connecting rods *i i* to the levers *e* and *f*, move simultaneously with the last-mentioned levers as the piston of the engine works to and fro. The lower ends of the levers *h h* are attached

by joints to the horizontal rods  $k l$ , and these rods are connected to the sliding blocks which move the legs or crutches  $m n$ . The horizontal rods  $k l$ , and also the blocks which carry the legs, slide along in rebated grooves, formed in the under side of the perch  $a$ , which grooves are represented by dots, and a portion of the side of the perch is removed in the figure, to show one of the blocks  $o$  with its rollers within. The block  $o$  has small vertical wheels, or anti-friction rollers, by which it is enabled to run freely along the rebate or ledge of the groove; it has also small horizontal rollers, to prevent the block from rubbing against the sides of the groove. In the under side of each of the blocks a pin  $p$  is fixed, which is intended to pass through the top of the legs  $m$  or  $n$ , and a small helical spring is placed upon the pin, and secured by a screw nut, for the purpose of keeping up the top of the leg against the under side of the perch, but yet affording it some degree of play. By the action of the steam engine, and the other mechanism connected thereto, the blocks  $o$  are made to slide reciprocally to and fro along the grooves of the perch, in the manner above described; and supposing one of the legs or crutches to be brought into the situation of  $m$ , the foot will take hold of the ground, and remain stationary, while the force of the machinery pressing against it will cause the carriage to slide forward, and the leg  $m$  to assume the situation of  $n$ , while  $n$  will be advanced into the situation of  $m$ ; and *vice versâ*. Thus, by the reciprocating movements of the machinery, the carriage will be progressively impelled forward by the crutches or legs. In order to turn the carriage round corners or angles in the road, the axle of the hinder wheels is made to move round horizontally, upon a central pin, by means of a strap or other contrivance applied at  $g$ . By this strap and a suitable handle or lever, the conductor guides the course of the carriage in a straight or curved direction.

No pretensions are made by Mr. Gurney in his specification of having invented any part of the machinery described therein but the "guide rollers" to the crutches, as the crutches themselves were suggested by previous patentees;



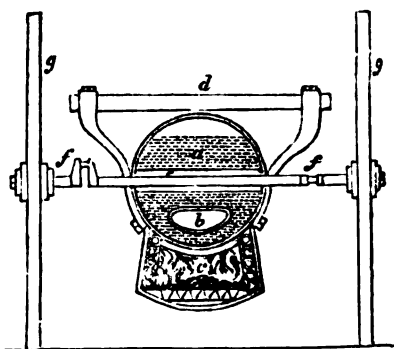
GURNEY.—1831.

and it will be seen that these crutches and rollers were abandoned as useless by Mr. Gurney himself. Were we to describe minutely the numerous contrivances and alterations made by the patentee and his assistant, it would occupy as much space as the whole of this article, and be at the same time a very uninteresting and profitless history of errors and failures, which few men having a knowledge of steam and machinery would have committed.

The preceding carriage represents one of the latest productions of Mr. Gurney, who built three upon the same model for Sir Charles Dance, which ran regularly from Cheltenham to Gloucester during a period of three or four months. These carriages were employed as *drags*, to draw after them the passengers contained in a light carriage of the omnibus kind. Only one of the drags was, we believe, in use at a time, the others being kept in dock to supply a fresh one, whenever repairs became necessary to the one in use.

An arrangement for a locomotive carriage was patented in December, 1826, by Mr. Frederick Andrews, of Stamford Rivers, in Essex; the peculiarities in which consist, first, in employing a single steering wheel in front of the carriage, the axis of which revolves in two lateral bars of a framing that connects it to the axletree of the four wheels, and thereby turns the latter with it. To give effect to this steering wheel, the framing is designed to carry luggage, or other sufficiently heavy articles. Another arrangement of the inventor's consisted in employing a pair of engines working upon pivots or trunnions, so that by their vibrations the piston rods might be directly connected to the throws of the crank, and adapt their inclinations to the varied motion of the latter. The other arrangements will be easiest understood by reference to the annexed cut.

*a* shows a vertical section of a cylindrical boiler; *c* is the furnace, the heated matters from which pass longitudinally under the boiler, and then return to the front through a central flue *b*, before it enters the chimney, not shown. Transversely through the centre of the boiler there is a tubular passage, open at each end, through which the axis of the wheels *g g* passes, sufficient space being made in that tube for the cranked portions *f f* of the axis also to pass through. The piston rods being connected to the throws of the crank, it of course causes them to revolve, and with them the wheels by which the carriage is propelled. The boiler is suspended by stout iron arms to a frame above, which forms a part of the general frame, and is supported upon springs; the furnace *c* is suspended to the boiler by straps, the sides of which are lined by a series of horizontal tubes, in connexion with the boiler, which serve the double purpose of intercepting lateral radiation, and of assisting in the generation of vapour.



ANDREWS'S STEAM CARRIAGE.—PATENT 1826.

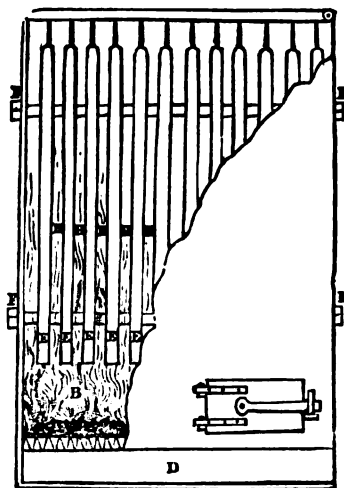
Mr. Neville, of Shad Thames, London, took out a patent for steam locomotion in 1827, the chief object of which appears from the specification to have been to prevent the wheels of a locomotive carriage from slipping round. To effect this he proposed the application of points and plates to the peripheries of the wheels. But as these contrivances were worse than useless, and the arrangements of the steam carriage contained nothing worthy of particular remark, we abstain from all detail.

Amongst the singular propositions for producing a locomotive action, was that invented by Mr. T. S. Holland, for which he took out a patent, in 1827. The invention consists in the application of an arrangement of levers, similar to that commonly known by the name of *laxy-tongs*, for the purpose of propelling carriages. The objects appear to be, to derive from the reciprocating motion of a short lever a considerable degree of speed, and to obtain an abutment, against which the propellers should act horizontally, in the direction of the motion of the carriage, instead of obliquely to that motion, as is the case

when carriages are impelled by levers striking the earth. The drawings attached to the specification seem designed rather to explain the principle than to represent what the patentee would deem an eligible form of its application: and as such an application is not likely to be ever considered eligible, on account of the excessive waste of power from friction, we must content ourselves by referring the reader who may require more information on the subject, to the inrolled document.

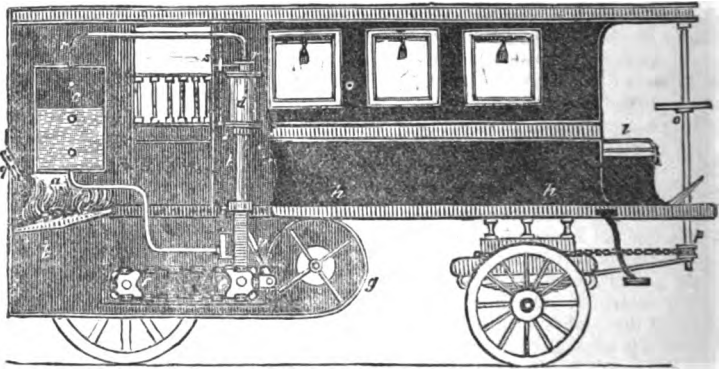
Two days after the before mentioned grant, Dr. Harland, of Scarborough, received the great seal for supposed improvements, which we doubt not proved inefficacious; we shall therefore give but a brief sketch of the nature of them. On a phaeton-like frame at the back of the carriage, are situated the boiler (composed of two double cylinders), the fire-grate, ash-pit, chimney steam chamber, water reservoir, and working cylinder, &c. After the steam has passed through the latter, it is conducted to a series of tubes, underneath, and in front of the carriage, for the purpose of condensation by the cooling influence of the atmosphere. The fruitlessness of such attempts, which has been long before determined (owing to the slow conductivity of the air), together with the defects of construction, renders it needless to enter into details.

Mr. Walter Hancock, in the year 1827, took out a patent for a high pressure boiler, for locomotive purposes. In the annexed engraving is represented an elevation of the first modification of this boiler, with a part of the casing removed to show the interior structure. At B is the fire-place; D the stoke-hole; E E are a series of flat parallel chambers to hold the water, made of the toughest sheet iron, and placed side by side, at a sufficient distance apart for the flames and heated air to pass up between them, as shown at H H. Each of these flat vessels extends across the furnace chamber, so as to fill its whole area in a vertical plane; and they are all connected at the bottom, for keeping the water in each at a uniform level; and at the top of each of the chambers there is a steam-pipe that leads into another larger steam-pipe, common to them all, and by which the engines are supplied. To keep the



individual water chambers E E at uniform distances apart, and confer, at the same time, adequate strength to them, a series of vertical bars or fillets are fixed between each pair. Therefore, instead of the flames ascending between each pair of plates in one unbroken sheet, it is subdivided, and made to pass through a number of rectangular channels, representing in their outline so many square tubes. This combination of water chambers and alternate flues is bound together by a system of very massive bolts externally, proved to be capable of sustaining a vastly greater pressure than the boiler is ever subjected to; and it is unquestionably a great merit in this boiler, that the thinness of metal, and consequent weakness of the individual water chambers, constitutes each, in effect, a safety valve. An increased efficiency was afterwards obtained by "embossing" the plates; by pressing them between dies, so as to cause a series of hemispherical bosses, of nearly the shape and size of watch-glasses, to be projected all over their external surfaces; so that when the chambers are brought together, the tops of these come into contact, and thus a series of spaces are formed between them, through which the heated gases ascend in a devious course, impinging successively upon each boss in their passage.

Mr. Hancock being satisfied that he had obtained in this boiler the requisite means of generating adequate power, turned his attention to the various arrangements of the carriage and propelling machinery. His first carriage was constructed upon three wheels, and the power was applied through the medium of two vibrating engines fixed upon the crank axle of the fore wheel. Finding this mode of applying the power direct to the crank axle practically ineligible, Mr. Hancock next placed the engine quite behind; new difficulties occurred in this arrangement, and a third carriage was built, and called in reference to the infancy of the undertaking, the "Infant."



HANCOCK'S STEAM CARRIAGE "INFANT."—1830.

At *a* is the fire-place, *b* the ash-pit, and *g* a blower. The fire place and ash-pit are made close, that is, admitting only of a current upwards. The fireman, who sits on a small seat behind the boiler, views the state of the fire through eyeholes, and supplies coke through a feeding hopper at *q*. Steam is supplied to the engines *d*, of which there are two, through a pipe *r*, regulated by a valve at *s*. At *t* is the parallel motion, converted into rotary by the connecting rod *c*, actuating a crank *e* in the axis of a pair of chain wheels. There are two other chain wheels on the axis of the running wheels; and two endless chains communicate the force and motion to the latter. The engines are fixed securely upon springs, also the cranks and pumps. Several subordinate contrivances we have not room to describe. This carriage was the first that ran on a common road for hire, which it did for several weeks together, between Stratford and London. Mr. Hancock built several carriages subsequently to the *INFANT*, which were at different periods on the public roads for hire, for months together. But they did not meet with that patronage that was expected.

The next locomotionist who received the great seal, was Mr. Nathan Gough, of Salford, some of whose arrangements possess originality, and are not destitute of merit. The form of the vehicle for the reception of the passengers is similar to that of an ordinary stage coach, having a great boot behind, and another in front, for containing the principal parts of the propelling machinery. Under the back seat of the carriage, extending its entire length, and about a foot more in depth, is an iron case, which encloses four vibrating engines on trunnions, working as many throws of a crank, radiating from their common axis at uniform angles of  $90^\circ$  with respect to each other. This cranked axis is lengthened out beyond the range of the engines about one foot on each side, whereon are placed two pitch chain wheels; around these pass two endless

pitched chains, which also go round two similar chain wheels, fixed to the running wheels of the carriage. The chain wheels are made so as to run loose upon the cranked shaft, and are fixable thereto at pleasure, by means of coupling boxes, placed under the control of the guide or steersman, so that he may slide them into or out of gear according to circumstances, by simple pressure with his feet upon two "foot levers," one for each foot, so that by pressing on the right, the chain wheels are locked to the axis, and, by pressure on the left, the wheels are unlocked by sliding back upon the axis, when they run loose; that is, the rotation of the axis by the force of the engines does not impart motion to it. By another movement the chain wheels are brought into action, with contiguous gear for producing a slow motion, as in ascending a hill; but when the work becomes lighter, the steersman, by his foot, shifts back the chain wheels to the quick motion, or he may entirely disengage the connecting parts, and thereby stop the progress of the carriage.

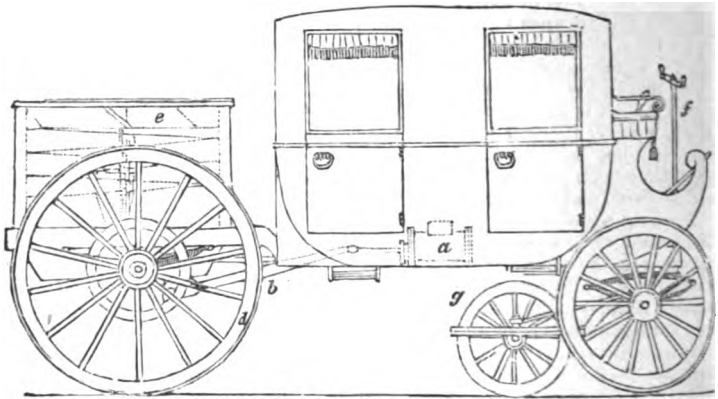
The front wheels of the carriage have separate independent axles, which turn horizontally upon a perpendicular column affixed to the fore framing. To guide the carriage, the steersman sitting in front turns a vertical spindle, the lower extremity of which carries two arms, that, by connecting rods attached to the separate frames of the two fore wheels, places them in the oblique direction required according to the curve of the road. Each of the fore wheels being thus made to turn on its own centre, renders the action of guiding exceedingly easy.

The boiler is situated quite at the back of the carriage, and it is judiciously formed of a large cylinder, with a series of small tubes passing through it for the furnace flues. The lower part of the boiler is divided by perpendicular partitions, to prevent the water from leaving it uncovered during the ascent or descent of hills or inclined planes, or from the effects of other disturbing causes. To regulate the admission of the steam to the cylinders, and its exit therefrom, a species of three-way cock is employed; this is placed under the control of the guide, so that he may diminish or increase the quantity, and by a further turn, should it be desired to stop the carriage suddenly, allow the steam to blow off. The steam from the last-mentioned cock next passes through a "distributing cock," and then enters each cylinder through passages on its trunnions, regulated by a cock fixed on each, which admits the vapour alternately on each side of the pistons, as the cylinders vibrate on their centres. The steam which is forced out of the working cylinders by the back stroke of the pistons, is conducted through a pipe into a chamber, which the patentee calls the heating chest; wherein is also received the steam that blows off from the safety valve. There is a vessel connected with the boiler, containing a float, by means of which the amount of water forced into the boiler is regulated. This pump is worked by a lever, acted upon by a cam, that revolves upon the crank shaft. The water for the supply of the boiler is forced by the pump through a long winding tube in the heating chest, by which the temperature of the fluid becomes considerably heated before it enters the boiler. There is also a float in the boiler connected with the water way of the pump, which, as the water rises in the boiler, closes the supply valve, so that if the pump continues in action, no more water can be injected, but it will be returned through the cold water pipe. There are two water tanks, one on each side of the carriage, next to the hind or propelling wheels, and between these tanks is the coal-hole.

In the year 1830, Messrs. Summers and Ogle obtained a patent for a steam carriage. The principal feature in it was the steam generating apparatus, which is already described in the article **BOILER**. The arrangement for communicating the force of the steam to the carriage wheels, consisted in forming the axis of the latter into a three-throw crank; each throw being equidistant, or at  $120^\circ$  apart from each other, for converting the rectilinear motion into rotary with the greatest uniformity of force; which motion was derived from three cylinders, vibrating on trunnions. Very flattering reports of the operation of this carriage were published, and others of a contrary character, but private interest probably influenced both sides of the question.

In the same year as the last mentioned invention, Messrs. Boase and Rawe

brought out a patent locomotive carriage, the annexed illustration of which will assist in the comprehension of it. The engines were situated in a case underneath the body of the carriage, as shown at *a*, and by the piston rod and



RAWE AND BOASE'S STEAM CARRIAGE.—PATENT 1830.

connecting rod *b*, gave motion to the cranked axles of the running wheels *d* of the carriage. The boiler *e* was bolted to a strong framing, and was contained in a double case, the space between being packed with non-conducting substances. The boiler consisted of 12 tubes of small diameter, each bent into a spiral curve of three convolutions, of the same pitch and height, but of uniformly varying diameters; so that when each successive spiral was placed side by side (the smaller inside the next larger in diameter) they formed by their concentric junction a continuous spiral sheet of tubes; with a steam chamber in the centre. Underneath the whole was the furnace of the entire area of the boiler, that is, about 4 feet 6 inches in diameter.

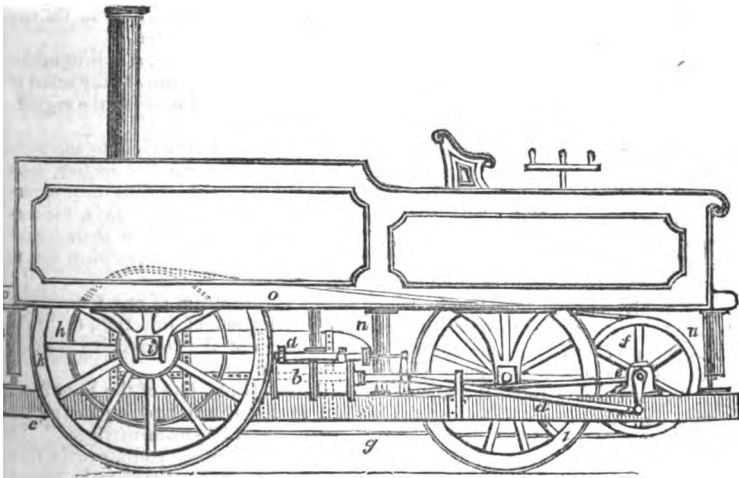
Messrs. W. G. and R. Heaton, of Birmingham, built several steam carriages under a patent-right dated 1830; but their mechanism was too complicated to be understood without the aid of drawings, which our space will not admit: and as the patentees had the remarkable candour to acknowledge publicly the failure of their scheme, a very brief notice is all that we are called upon to give: and for this further reason; because the Messrs. Heaton did not pretend to have invented any of the separate or distinct parts of their machine, but merely the general combination of the entire structure, which is a claim of scarcely any value to the most successful inventor; the identical combination being so easily destroyed. Their boiler was of the tubular kind, with a cylindrical arrangement, like James's; their steering apparatus was also like that of the same person; their engines after some other locomotionist, and so on throughout most of the parts. In the annexed condensed extract from the specification, descriptive of their mode of applying the steam power to the vehicle, they have availed themselves of the plans of the renowned progenitor of steam coaches, Trevithick.

Motion is communicated to the driving wheels by a double set of spur wheel gear, arranged to give different powers or velocities, by having both a large and a small wheel fixed on the driving as well as the driven axis. By shifting the large wheel on the driving axis into gear with the small wheel on the driven axis, speed is obtained; and by shifting their relative position till the small wheel on the driving axis comes into gear with the large wheel on the driven axis, power is obtained at the expense of speed. These two axes are kept at the same distance from each other by means of connecting rods,

notwithstanding the relative position may be changed by the motion of the carriage on rough roads.

Messrs. Napier describe their improvements in steam carriages to consist:—

First, in communicating the power of the engines for propelling the carriage to the wheels, by means of a belt, strap, or band, which works upon two pulleys, the one fixed upon a shaft connected with the engine or engines, the other fixed upon, or connected with, the axle or wheels of the carriage. This will be better understood by reference to the annexed cut. *a* is a horizontal steam boiler, with an hemispherical end; at *b* are the two cylinders of the engines working horizontally, and fastened upon the boilers; *c c* is the framing of engines, which is also fastened to the boilers and engine cylinders; *d* connecting rod of engine; *e* the crank shaft of engines, upon which is fixed the pulley or drum *f*, from which pulley the strap *g* communicates the power of the engine to the pulley or drum *h*, which in the present case is fixed on the middle of the



NAPIER'S STEAM CARRIAGE—PATENT 1831.

wheel axle, *i*; *k k* the hind wheels of carriage; *l* fore wheel of carriage, which turns on a circular plate for the purpose of guiding the carriage on the common roads. The boilers and engines being firmly fastened together, thus form one entire piece, which is suspended by springs *n n n*, from a frame work *o o*, resting upon the wheel axles of the carriage, and having no connexion with the said carriage or frame-work, but by belts, straps, or bands, which are designed to free it from jolts and concussions.

A patent, for a variety of improvements in locomotion, was granted to Mr. W. H. Palmer in 1831; but the specification is so extensive and elaborate, that we can do no more than state his claims to invention, and refer the reader to the Inrolment Offices for the details. These are as follow:—

First, The self-regulating blast apparatus, by which the quantity of fuel to be ignited in a given time is governed, in order to insure the generation of a volume of steam, suited precisely to all the variable speeds and powers of the engine.

Secondly, The steam calorific self-adjusting apparatus, which acts in conjunction with the blast regulator, and is so contrived as to lift the weight from the lever of the safety valve, and permit the steam to escape from the boiler should the aforesaid apparatus fail of instantly checking its evolution.

Thirdly, The self-acting safety apparatus, by which the security of the boiler is insured, should the apparatus for supplying it with water fail in its effect, so



that in the event of the water in the boiler being reduced below a determined level, the process of combustion will be instantly suspended, and the boiler protected from injury.

Fourthly, Making the products of combustion evolved from the furnace escape into the atmosphere below the level of the furnace bars, which will most effectually prevent the admission of atmospheric air into the furnace, excepting that portion which the blast and calorific regulating apparatus permits the blowers to project upon the fuel undergoing combustion.

Fifthly, The pipes leading from the opposite ends of the horizontal part of the boiler are designed to convey the water (which must be distilled) most remote from the direct action of the furnace, to replace that portion which may be carried to the upper part of the boiler by the great volume of steam generated between the two concentric cylinders.

Sixthly, To insure a length of stroke in high pressure engines, and that without increasing the diameter of the piston rods beyond that which is required to withstand the alternate tug and thrust; and without resorting to the very objectionable short stroke and piston rod of so large a diameter.

Seventhly, The slide valves, with their various modifications, requiring neither casings nor stuffing-boxes, the patentee claims as perfectly novel; the action of these being seen, admit of mathematical adjustment, and enables the engineer instantly to reverse or stop the engine at pleasure.

Eighthly, For a modification of the crank and beam intended to supersede the use of a beam of the usual weight and dimensions, parallel motion, cross heads, and costly fittings and bearings connected therewith. This mode of converting the reciprocating into the rotative motion, the patentee says, "accomplishes the grand desideratum of making one cylinder produce a more regular and equalized motion than can be accomplished by two cylinders when used to give motion to locomotive engines or paddle wheels."

Ninthly, The condensation by which highly elastic steam of any temperature may be converted into water, without the application of injection, or by the extension of surface by making the cubic contents of the condensing chamber equal to the number of cubic inches of steam discharged.

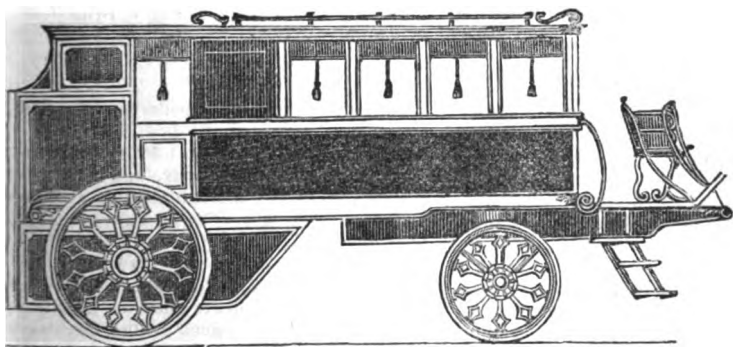
We have now to notice the labours of Mr. Joseph Gibbs, late of the Kent Road, and Mr. Augustus Applegath, of Crayford in Kent, who had a joint patent, dated 29th March, 1833, for "certain improvements in steam-carriages." To give an intelligible description of the many contrivances contained in their elaborate specification, our space is inadequate; we must therefore be content with giving an idea of the nature of the subjects, and refer the inquiring reader to the enrolled parchments.

The first described improvement relates to the general arrangement of a steam-carriage. The boiler is of a novel description, and consists of a series of double cones arranged one over the other, the external angles or spaces between which are receptacles for water, which is circumscribed externally by a cylindrical casing. The fire is in the centre of the series of cones, and operates upon their extensive surfaces; and the flue is so arranged as to repeat the heating operation by a descending current. There is also a curious combination of shafts, wheels, couplers and springs for varying the speed, &c.

The locomotive carriage, contrived by Dr. W. H. Church, being patented in 1832, next comes under our observation. The principal novelties claimed by him, consist; first, in making the frame of the carriage of a combination of wood of small scantling combined with angle iron, to give it the requisite strength. A framework of this kind, well trussed and braced, incloses a space between a hind and fore-body of the carriage, and of the same height as the latter, and is to contain the engines, boiler, &c. The boiler consists of a series of vertical tubes, into each of which is introduced a pipe that passes through, and is secured at the bottom of the boiler tube. The interior pipes constitute the flues, each of which, after passing through the boiler tube, is bent syphon-wise, and passed down till it reaches as low or lower than the bottom of the fire-place, whence it passes off into a general flue in communication with an exhausting apparatus. Some other complications of tubes form a part of the arrangement,

which our limits forbid us to describe. Two fans are employed, one to blow in air, and the other to draw it out; they are worked as usual, by straps from the crank shaft. The wheels of the carriage are constructed with the view of rendering them to a certain degree elastic, in two different ways: first, the felloes are made of several successive layers of broad wooden hoops, and these are covered with a thin iron tire, having lateral straps to bind the hoops together; second, these binding-straps are connected by hinge joints, to a kind of flat steel springs, somewhat curved, which form the spokes of the wheels. These spring spokes are intended to obviate the necessity, in a great measure, of the ordinary springs, and the elasticity of the periphery is designed that the yielding of the circle shall prevent the wheel from turning without propelling! Dr. Church, however, proposes, in addition to spring felloes, spring spokes, and the ordinary springs, to employ air springs, and for that purpose provides two or more cylinders, made fast to the body of the carriage, in a vertical position, closed at top, and furnished with a piston, with packing similar to the cap-leather packing of the hydraulic press: this piston is kept covered with oil, to preserve it in good order, and a piston-rod connects it with the supporting frame of the carriage. Motion is communicated by two oscillating steam cylinders, which are suspended on the ends of the eduction and induction pipes over the crank shaft. The crank shaft and driving-wheel axle are connected together by means of chains passing about pitched pulleys; and there are two pairs of these pulleys, of different sizes with respect to each other, by which the power may be varied, by shifting the motion from one pair to the other, by means of clutch boxes.

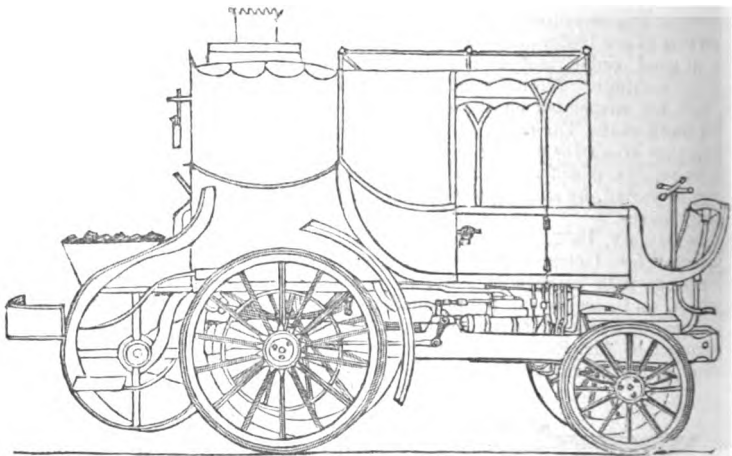
In October, 1832, Mr. Redmund, of the City Road, patented a boiler, especially designed for locomotive uses. It consists of a series of parallel vertical chambers with corrugated sides, for the purpose of extending the heating surface, and accelerating the production of steam in a compact apparatus. The principal difference between it and Mr. Hancock's, is in the circumstance of the corrugation. Mr. Redmund, shortly after the grant of his patent, constructed a steam carriage, which is represented in the subjoined cut. The wheels are



entirely metallic; the spokes are cast hollow or tubular, and of an ornamental design. The arrangement and position of the chief part of the propelling mechanism is the same as Hancock's. The guiding is effected by reins in a similar manner to those of horses, each rein operating separately through the medium of levers in turning the fore wheels of the carriage to the right or left; and to facilitate this motion, each wheel revolves on a distinct axle supported in a frame that turns horizontally upon a pivot, after the manner of Ackerman's patent of 1816.

A tubular boiler for locomotive purposes, was patented jointly by Mr. John Squire and Colonel Maceroni, on the 18th July, 1833. It consists of nine rows

of upright cylindrical tubes, each row containing nine tubes. In the middle of these the fire-place is situated; and to obtain the requisite space for it and the fuel under combustion, a portion of the interior ranges of tubes are proportionably shortened, as well as three of the front tubes, to form a fire-door. All the vertical tubes are connected by means of small horizontal tubes at the top and at the bottom; the upper being a steam communication, and the lower a water communication; but as they are all open to each other, and the application of the heat cannot be precisely uniform in every part, a circulation of the fluid necessarily ensues. The fire-bars are formed of hollow tubes, filled with water, and communicating with the vertical tubes. The steam is conducted from the latter tubes by means of small pipes entering the otherwise close tops of each, into a central recipient, from which the engine is supplied. The engine

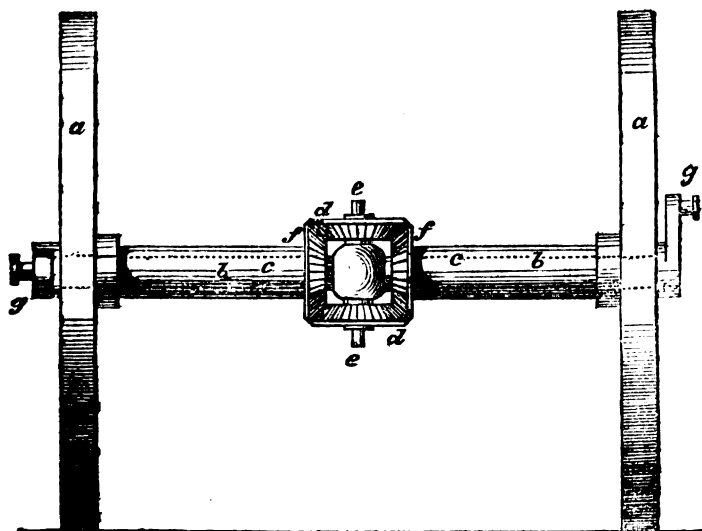


are placed horizontally underneath the carriage body; the boiler is at the back, and a blast is employed to excite the combustion of the fuel, the supply of which is regulated by an engine man, who has a seat at the back for attending to it. The passengers are placed in the open carriage body, and their seats are formed upon the tops of the water tanks. There are two working cylinders  $7\frac{1}{2}$  inches diameter, and  $15\frac{1}{2}$  inches length of stroke. The steam-ways are  $2\frac{1}{2}$  and  $2\frac{3}{4}$  inches diameter.

The last experimentalist in the department of common road locomotion whose labours we shall notice, is Mr. F. Hills, of Deptford. Mr. Hills devoted much time and went to great expense in his endeavours to construct a compact and efficient boiler, and to bring the weight and dimensions of the machinery within moderate and practical limits; and at length so fully mastered the practical difficulties of his task, that a company was formed for building and running carriages constructed according to his plan, and an act of incorporation was applied for; but failing to obtain the clause for limiting the responsibility of the shareholders to the proportion of their shares, and the railway mania beginning to manifest itself at the same time, the company was dissolved, and Mr. Hills retired from the field. In the course of his experiments, Mr. Hills constructed several carriages with which he performed numerous journeys on the public roads; selecting those which, from the peculiar difficulties they presented, were most likely to point out every variety of provision that required to be made, or circumstances to be guarded against. The Windsor, Brighton, Hastings, and similar roads were traversed by him with uniform success; and

amongst other performances, we may state, that the journey to Hastings (64 miles) and back was performed in one day, each journey being accomplished in one half the time occupied by the coaches. One of the improvements comprehended in the last of Mr. Hills' patents, from its originality, extreme ingenuity, and the perfect manner in which it attains the object in view, calls for particular notice. One of the difficulties attending the construction of locomotive carriages, is the connexion of the driving wheels with the machinery, so as to obtain the full adhesion of the wheels, and at the same time to allow facility in turning sharp curves. Mr. James, as we have already noticed in one of his earliest attempts, fixed each of the driving wheels upon a short and separate axle, and applied two steam cylinders (at right angles to each other) to drive each wheel, but this added greatly to the complexity of the apparatus; another inventor employed only three wheels in his carriage, and applied the power to a single wheel, which ran in advance of and between the tracks of the other two. The plan, however, most commonly resorted to, was to fix one wheel to the axle and to connect the other to the axle by a sliding clutch; but as it was impossible for the steersman to lock and unlock the wheels at every sudden turn the carriage might be required to make, and great friction would have been created by the *skidding* of the wheels had both been fixed, the practice was to drive generally with only one wheel fixed, and to lock the other in ascending hills, where the whole amount of adhesion might be required. By Mr. Hills' arrangement, the objections to which all previous plans were liable are completely obviated; the adhesion of both wheels is constantly exerted to propel the carriage, and without the slightest attention on the part of the driver, the power exerted by the engines is exactly proportioned to the space each wheel passes through in describing the sharpest curves.

The engraving represents Mr. Hills' arrangement for connecting the driving wheels with the axle and the engines. *a a* are the driving wheels, which are



fixed upon two tubes or boxes; *b b* through which the axle or driving shaft *e* passes, as shewn by the dotted lines, the tubes being loose upon the shaft; *d d* are two bevelled wheels which turn upon two pins *e e*, fixed upon the centre of the shaft, and which work into two similar wheels *f f*, fixed upon the tubes *b b*,

the four wheels being all geared together; *g g* are the cranks fixed upon the ends of the shaft at right angles to each other, and to which the connecting rods are attached. Upon examining the figure it will be seen, that so long as the wheels continue to run in a straight line, the tubes *b b* do not revolve upon the axle, but turn round with it, and carry round the wheels as if they were fixed to the axle; but upon any deviation from a straight line, the wheels, at the same time that they advance with the axle, revolve more or less (according to the sharpness of the curve) upon the axle in contrary directions, the outer wheel having a forward, and the inner wheel having a backward movement; so that the actual advance of the outer wheel exceeds that of the inner wheel, as much as the length of the outside curve exceeds that of the inside curve, and thus no skidding takes place.

**STEAM ENGINE.**—A machine wrought by the force obtained from the expansion and contraction of the steam of boiling water, and employed as a first moving power to other machines.

Before proceeding to describe the construction and arrangement of the engine, it will be proper to give a brief exposition of the principles upon which the action of it depends.

The mechanical power exerted is the effect of the physical changes produced in water, by great and sudden alterations of its temperature. By an addition of heat, it is changed from a dense incompressible liquid, into an invisible, highly elastic fluid, the bulk of which exceeds, by many hundred times, that of the water of which it is formed. This change of state, however, is not permanent; an abstraction of the heat from the steam reducing it again to water. These changes, either separately or combined, are the cause of motion in every modification of the steam engine.

The effects of heat upon water are of two kinds; it first raises the temperature until it reaches a certain point, when it becomes stationary; and the continued action of heat then converts the water into steam; the temperature of which remains the same as that of the water from which it is formed. But although the *intensity* of the heat of steam, as indicated by the thermometer, is the same as that of the boiling water; the *quantity* of heat in a given weight of steam, exceeds considerably the quantity of heat in the same weight of boiling water. This heat is that which is necessary to maintain the water in the state of vapour; and if any portion of it be withdrawn, a corresponding portion of steam is rendered liquid. From the heat not being apparent by the thermometer, it is termed *latent* heat. The quantity of latent heat combined with steam, is variously given by different authors; the best experiments appear to fix it at about 1000, or about  $5\frac{1}{2}$  times the heat of boiling water; it being found that 1lb of water converted into steam, will raise  $5\frac{1}{2}$ lbs of water from  $32^{\circ}$  to  $212^{\circ}$  Fahr. From various experiments it likewise appears, that the latent heat is nearly the same, whatever be its temperature as indicated by the thermometer.

The temperature at which water boils or is converted into steam depends upon the pressure upon the surface of the water. Exposed simply to the common pressure of the atmosphere, water boils at  $212^{\circ}$  Fahr.; but upon the top of lofty mountains, where the mercury in the barometer indicates a much smaller pressure, the temperature of the boiling point is proportionately lower; and on the other hand, if water be confined in a vessel from which there is no escape for the steam until it attains a certain pressure, the temperature of the boiling point will be proportionately raised.

In like manner the pressure of the steam varies with and is proportional to the temperature at which it is formed. The determination of the elastic force of steam of different degrees of temperature, is of the greatest importance to the practical engineer, and the subject has consequently undergone much investigation. The experiments of Watt, Dalton, Robins, Southern, Ure, Arsberger, and Philip Taylor have all been of great service in determining this question.

The two tables given for greater perspicuity in the next page—the first being the result of a series of experiments made by Dr. Dalton, the second supplied by the Royal Academy of France, in their report upon the comparative degrees of safety between high and low pressure engines—are inserted as being not only

essential:

TABLE

*Of the Expansive Force of Steam when contained in a close Vessel, taken at every 10° of Temperature from 212° Fahrenheit, (the Boiling Point,) up to 320°.*

TEMP. Fahr.	Pressure of Steam, or the Force which it will exert to enter into a vacuous Space.			Pressure of the Steam against the Atmosphere, when the Barometer is at 30 Inches, or the Force it will exert to escape from the closed Vessel into the open Air.		
	Column of Mercury.	Column of Water.	Pressure per Square Inch.	Column of Mercury.	Column of Water.	Pressure per Square Inch.
	<i>Inches.</i>	<i>Ft. In.</i>	<i>Lbs. Oz.</i>	<i>Inches.</i>	<i>Ft. In.</i>	<i>Lbs. Oz.</i>
212	30.	33 11	14 11	The Steam equal to the atmosph.		
220	35.	39 6	17 1	5.	5 7	2 7
230	41.75	47 2	20 7	11.75	13 4	5 13
240	49.67	56 1	24 4	19.67	22 3	9 10
250	58.21	65 9	28 8	28.21	31 11	13 14
260	67.73	76 6	33 2	37.73	42 8	18 8
270	77.85	87 11	38 1	47.85	54 1	23 7
280	88.75	100 3	43 7	58.75	66 5	28 13
290	100.12	113 1	49 0	70.12	79 3	34 6
300	111.81	126 4	54 12	81.81	92 6	40 2
310	123.53	139 6	60 8	93.53	105 8	45 14
320	135.	152 6	66 1	105.	116 5	51 7

Elasticity in Atmosphere.	Height of Mercury in Inches.	Temperature of Fahrenheit.	Pressure per Square Inch, in lbs. Avoirdupois.
1	29.92	212.	14.61
1½	44.88	234.	21.92
2	59.84	251.6	29.23
3	89.76	275.	43.84
4	119.69	293.4	58.46
5	149.61	309.2	73.07
6	179.53	322.7	81.69
7	209.45	334.4	102.30
8	239.37	343.4	116.92

essential to the practical engineer, but of the greatest interest to the scientific engineer. They differ in no very material point from other calculations that have been made, and are quite near enough to be adopted as a standard for guidance in mechanical operations.

The volume of steam into which a given quantity of water expands, depends upon the pressure of the steam. At the temperature of  $212^{\circ}$ , one volume of water furnishes nearly 1,800 volumes of steam, of a pressure equal to that of the atmospheric, or about 15lbs on the square inch. With an increased pressure its bulk is diminished, but in what ratio is not quite settled. From the experiments of Mr. Southern and also those of MM. Clements and Desorme, all conducted with great care, the same law appears to hold good with respect to steam, as with other æriform fluids, that the density is directly as the pressure, or the volume inversely as the pressure. Thus, if at the pressure of the atmosphere or 15lbs per square inch 1 volume of water will furnish 1,800 volumes of steam; at the pressure of 2 atmospheres or 30lbs, it will give 900 volumes; at 4 atmospheres 450 volumes, &c. and this is the theory most generally adopted.

The motion of steam engines is derived from the following causes, namely:—

*First*, From the direct pressure of steam upon the piston. *Second*, From the condensation of steam on one side of a piston, and by the vacuum thus effected, obtaining the pressure of the atmosphere on the other side. *Third*, From the combined action of the pressure of steam on one side of a piston, and of a vacuum on the other side effected by condensation. To these may be added a *fourth*, which, for want of a more appropriate term, has been called the "reaction" of steam. The theory of the action in each case we will now briefly explain.

It has already been observed that water when converted into steam is increased in its bulk about 1800 times, at atmospheric pressure. It follows that a cubic inch of water will furnish a cubic foot of steam. Let us suppose a cylinder whose area is equal to one square foot, to contain a cubic inch of water; on the surface of which rests a steam tight piston, but which is free to move without friction, and that the weight of the piston is counterbalanced by a weight suspended from a line running over a pulley. If heat be now applied to the bottom of the cylinder, and the water be thereby converted into steam, the piston will be raised one foot high in the cylinder. In this case, however, no mechanical power is obtained, as the steam has merely overcome the pressure of the atmosphere. But let us suppose that in addition to the pressure of the atmosphere upon the piston, a load equal to 15lbs upon each square inch of its area, be placed upon it; the pressure of the steam will in this case be doubled, and will consequently raise the piston six inches in the cylinder; and the mechanical effect will be, 144 times 15lbs raised through the space of 6 inches. If the load upon the piston be increased to 30lbs, making with the pressure of the atmosphere 45lbs, the pressure of the steam will be trebled, the piston will be raised 4 inches in the cylinder, and the effect will be  $144 \times 15$  through the space of 4 inches, exceeding the former effect in the ratio of 120 to 90: had the load been increased to 45lbs, exclusive of the atmosphere, the piston would have been raised through 3 inches, and the effects would have been as 135 to 90.

The cause of this increase of mechanical effect, by an increased pressure of steam, is, that in each instance, in addition to the mechanical load to be moved, there is the pressure of the atmosphere to be overcome, which in the first case amounted to one half the whole load, but in the last case to only one fourth of the whole load; the greater the pressure therefore of the steam, the greater the mechanical effect, or rather the smaller the loss of effect. But considerations of safety, and other circumstances, prevent this principle from being carried to a great extent in practice.

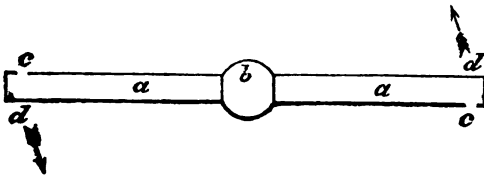
To illustrate the principle upon which the condensation of steam tends to produce a mechanical power; let us suppose that in the before described cylinder, the cubic inch of water has formed a cubic foot of steam, the pressure of which just balances the pressure of the atmosphere upon the piston, which will then be raised one foot high in the cylinder; if by any means the steam be suddenly condensed and reduced to one cubic inch of water, a vacuum will be

formed beneath the piston, and the pressure of the atmosphere upon its surface, being no longer balanced by that of the steam beneath, will carry the piston to the bottom of the cylinder, with a force of 15lbs upon each square inch of its surface, or 2,160lbs in the whole. And if a weight of 2,160lbs be supposed to be attached to the line to which the counterbalance is hung, it will, by the descent of the piston in the cylinder, be raised one foot high; the mechanical effect therefore in this case is 2,160lbs raised 1 foot high. The above may be taken as an illustration of the principle of the atmospheric engine, as it is termed, which is the first form of the steam engine, in which the force of the steam was transmitted through a piston.

As respects the third mentioned cause of motion in steam engines, viz. the force produced by its pressure, combined with that resulting from its condensation;—the pressure of the steam is substituted for the pressure of the atmosphere, to impel the piston into the vacuum formed within the cylinder by the condensation of the steam. In this case the reader must suppose the cylinder before described to be fitted with a steam-tight cover, through a hole in which a rod attached to the piston works steam-tight, and that upon this rod is placed the load to be raised. If a vacuum be formed above the piston, and the cubic inch of water below the piston be converted into steam, the piston will be raised through a space which will be inversely as the amount of the load; thus, if the load be equal to 15lbs upon the square inch, it will be raised 1 foot high; if 30lbs per square inch, it will be raised only 6 inches; and so on, the product of the weight, multiplied by the space through which it is raised, being equal in all cases. Theoretically considered, therefore, the mechanical effect of a given quantity of water, converted into steam, is the same whatever the pressure of the steam may be; and is equal to that produced by the effect of the pressure of the atmosphere against a vacuum. But it is advantageous on many accounts, in practice, both to substitute the pressure of the steam for that of the atmosphere to impel the piston, and also to increase its elastic force beyond that of the atmosphere.

With respect to the fourth cause of motion in engines;—if steam be made to flow from a centre along a hollow arm, and to issue in a jet, near the extremity, in a direction at right angles to such arm, it will impart a rotary motion to the arm in an opposite direction to that of the jet. This motion is attributed by many to the “re-action” of the steam against the atmosphere, which is supposed to form the abutment to the steam. But this explanation is clearly incorrect, since engines constructed upon this principle of action will revolve in a close casing in which a vacuum is maintained.

Another, and, as it appears to us, the true theory, is that it results from a difference of pressure on the opposite side of the arms; which may be illustrated thus. Let *a a* in the diagram be supposed to represent two hollow arms, capable



of motion upon a hollow axis *b*, through which steam is admitted to the arms. If these arms have no outlet, the pressure of the steam will be the same in every part of their surface; and there being no issue of steam, no motion will take place. But if a small aperture be made in each arm at *c c*, the steam will rush out through them, and the pressure upon that side of the arms will be removed; whilst it will continue to be exerted upon the opposite points of the arms at *d d*, and the arms will therefore revolve in the direction of the arrows.

Having now explained the *theory* of the several causes of motion in the steam engine, we shall proceed to show the *practical* application of them, by the



description of a series of different engines, that are actuated by those several causes of motion; in doing which we shall introduce them in the order of their discovery, our space not admitting of a historical detail of the successive steps by which the steam engine became the powerful and elaborate machine which it now exhibits.

The earliest contrivance of which we have any account, for making use of the force of steam, is of unknown date. It is generally called Hero's engine, and though posterity is really not indebted to him for the invention, it is still more beholden to him for the bequest of his description, than if he had been the inventor and omitted to describe it.

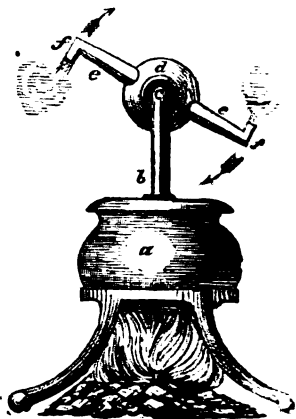
Hero, *the elder*, was the son of a Greek, settled at Alexandria, who flourished about 130 years before the Christian era. In his work entitled *Spiritualia*, he describes, among other ingenious machines, three modes in which steam might be employed as a mechanical power; to raise water by its elasticity, to elevate a weight by its expansive force, and to produce a rotary motion by its reaction on the atmosphere. Although these contrivances only took the shape of philosophic toys, we have in them the undoubted germs of the vast power which its present modification permits. Hero in the introduction to his work professes to have made himself acquainted with the works of his predecessors and contemporaries; and, unwilling that they should perish or be overlooked, described them, that they might be better and more generally understood; so that it is probable the properties of expansion and contraction of steam were known long prior to the time in which he flourished.

The following is a brief description of the machine described by Hero for producing a rotary motion; the leading features of which have been the subject of several patents, taken out by uninformed persons; and there are several machines now in use on the same principle.

Hero's engine consisted of a hollow globe, having tubular arms, extending from it radially in opposite directions; and each of these tubes had a small opening on one of its sides near the extremity. The globe was suspended upon horizontal centres, one of which was hollow, and admitted steam, from a caldron situated beneath, with a fire under, into the hollow globe, which passing through the radiating tubular arms, issued laterally against the atmosphere, and produced a rotary motion, in the same manner as water produces that of Barker's mill.

At *a* is a caldron of water with a fire underneath it. The caldron is closed at the top, except at the pipe *b*, which is bent horizontally at *c*, and forms one of the two centres; the other is not visible, as it is behind *b c*; *d* is the hollow globe, *e e* the hollow arms, bent at *f* into right angles, for the emission of the steam in that direction.

The next proposal for the useful application of steam as a motive power, is to be found in a work by Solomon De Caus, an eminent French mathematician and engineer, published in 1615, entitled, "Les Raisons des Forces mouvantes, avec divers Desseins de Fontaines." The following description will explain the principle of his invention. *a* is a spherical vessel placed over a fire, it is furnished with two pipes *b e*. The pipe *e* is open at the top and reaches down to the bottom of the vessel *a*: the pipe *b* is furnished with a cock *d* and funnel *c*: the vessel being filled with water, and fire applied, steam is speedily generated on the surface of the water, and having no other way to escape, (the cock *d* being shut,) presses on the surface and so forces the water up the tube *e* into the air, causing a jet, which varies in proportion to the elasticity of the steam within. It is upon the strength of the above invention, that De Caus has by



many been regarded as the inventor of the steam engine; and although we cannot quite concur in this opinion, we certainly regard him as entitled to great credit; for although the arrangement was such as could not be beneficially applied in practice, we have here the distinct announcement of one of the principles upon which Savery, nearly a century afterwards, constructed his engine, which is the first effective one on record.

In 1663 the Marquis of Worcester published a small tract entitled, "A Century of the Names and Scantlings of such Inventions as he had tried and perfected." In the 68th article of this Century he gives an inflated, boastful account of his "fire water-work," and in so obscure and contradictory a manner, that every commentator and writer on the steam engine, who has attempted to make out something reasonable from the pretended description, has been compelled to contrive and arrange what probably never entered into the imagination of the Marquis. Nevertheless, by many writers, implicit credit seems to be given to his assertions, and he is regarded as the inventor of the steam engine!

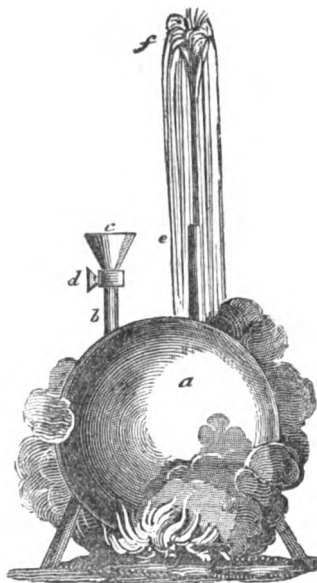
As far as the *principle* of his apparatus can be understood from his account, it appears to be the same as that which had been discovered, and much more clearly described, by De Caus fifty years before.

Although various expositions of the properties of steam, and suggestions for their application to move machinery, continued to be made from time to time by various persons, it is to Thomas Savery that we are indebted for the practical introduction of the steam engine as a moving power.

The following figure and description, nearly in Savery's own words, will illustrate the nature of his engine.

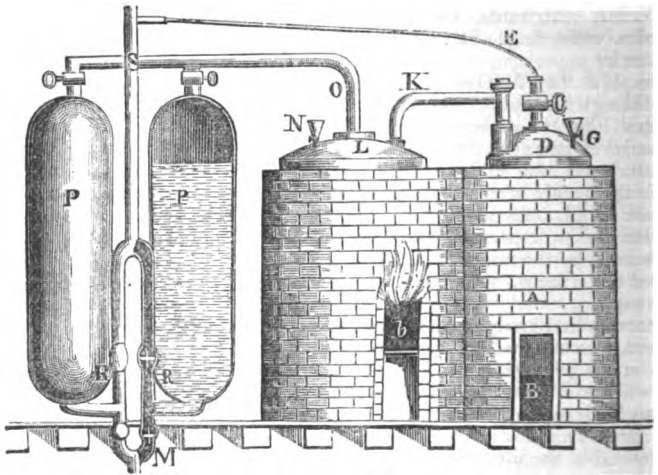
The first thing is, to fix the engine in a good double furnace, so contrived that the flame of your fire may circulate round and encompass your boilers, as you do coppers for brewing. Before you make any fire, unscrew G and N, being the two small *gauge pipes* and cocks belonging to the two boilers; and at the holes fill L, the large boiler, two-thirds full of water, and D, the small boiler, quite full. Then screw on the said pipes again, as fast and as tight as possible. Then light the fire at *b*, and when the water in L boils, open the cock of the first vessel P, (shown in section,) which makes all the steam rising from the water in L pass with irresistible force through O into P, pushing out all the air before it through the clack R; and when all is gone out, the bottom of the vessel P will be very hot; then shut the cock of the pipe of this vessel, and open the cock of the other vessel P, until that vessel has discharged its air through the clack R up the force-pipe S. In the mean time, a stream of cold water [supplied by a pipe connected with the discharging pipe, but not shown in the cut,] has been made to pass over the outside of the vessel P, which, by *condensing the steam within*, a vacuum or emptiness is created; so that the water from the well must and will necessarily rise up through the sucking-pipe, (cut off below M,) lifting up the clack M, and filling the vessel P.

The first vessel P being thus emptied of its air, open the cock again, and the force of steam from the boiler presses upon the surface of the water with an elastic quality like air, still increasing in elasticity or spring, till it counterpoises



DE CAUS'S ENGINE, 1615.

or rather exceeds the weight of water ascending in the pipe S, out of which the contained water will be immediately discharged when once gotten to the top, which takes up some time to recover that power; but having once got it, and being in work, it is easy for one that never saw the engine, after half an hour's experience, to keep a constant stream running out the full bore of the pipe. On



*Savery's Engine, 1699.*

the outside of the vessel you may see how the water goes out, as well as if the vessel were transparent; for as far as the steam continues within the vessel, so far is the vessel dry without, and so very hot as scarcely to endure the least touch of the hand. But as far as the water is, the said vessel will be cold and wet where any water has fallen on it, which cold and moisture vanish as fast as the steam, in its descent, takes place of the water; but if you force all the water out, the steam, or a small part thereof, going through P, will rattle the clack, so as to give sufficient notice to change the cocks, and the steam will then begin to force upon the other vessel, without the least alteration in the stream; only sometimes the stream of water will be somewhat stronger than before, if you change the cocks before any considerable quantity of steam be gone up the clack R: but it is better to let none of the steam go off, for that is losing so much strength, and is easily prevented by altering the cocks some little time before the vessel is emptied.

The wood-cut represents two reservoirs, P P, designed for *alternate* action; the tube E conveys water from the discharging pipe, to replenish the boiler L, when the water in it is almost consumed; and this is done by keeping D supplied with water, and (lighting the fire at B) generating a sufficiency of steam to press the water into L, through the pipe K. This will convey a tolerably correct idea of Savery's engine, and the mode of its operation. He gives no proportions of its parts, nor perhaps had he established any rule of action. He appears to have considered the strength of his machine to be the only limit to be observed; "for," says he, "I will raise you water 500 or 1,000 feet high, could you find us a way to procure strength enough for such an immense weight as a pillar of water of that height. But my engine at 60, 70, or 80 feet, raises a full bore of water with much ease."

Such was the machine which first solved the problem, which had so long occupied the attention of many ingenious and talented men, of employing the power of steam as an auxiliary to, or substitute for, the other sources of mechanical power then known. In simplicity of construction and of action.

and in its perfect freedom from friction, the machine has never perhaps been exceeded, although it was subsequently superseded by Newcomen's engine, when it was required as a machine to raise water from great depths; yet from the fewness of its parts, and from its little liability to derangement, it was occasionally employed, until a very recent period, in cases where great power was not required.

Various contrivances were supplied by different persons, by which it was rendered self-acting. In 1819 Mr. Pontifex of Shoe Lane, London, obtained a Patent for improvements in this description, and erected an engine upon this principle at the City Gas Works, which we shall subsequently notice.

Although Savery's invention proved of considerable utility, yet it possessed certain inherent defects which greatly limited its sphere of action. The principal of these defects were, first, the great strain to which the boilers and steam vessels were subjected; for the force of the steam being exerted directly upon the surface of the water to be raised, the pressure of the steam was required in all cases to exceed that of the ascending column of water. The second, and perhaps even greater, defect was the enormous consumption of fuel occasioned by the steam vessel at each successive discharge, being alternately raised to the temperature of the steam, and cooled down to the temperature of the water.

Scarcely had Savery's engine been brought sufficiently into operation to call attention to the defects we have noticed, when by a different application of one of the principles, a machine of a totally different character was produced by which the first of these defects was completely obliterated. This was the atmospheric engine invented by Thomas Newcomen and John Cawley, the former a blacksmith, and the latter a glazier, in the town of Dartmouth, in Devonshire.

Instead of applying the pressure of the steam directly upon the surface of the water, they employed the steam to produce by its condensation a vacuum beneath a piston, moving in a cylinder and exposed to the atmosphere, and the power thus acquired they applied to work pumps through the intervention of a beam. By this arrangement, the pressure of the steam was not in any case required to exceed that of the atmosphere, as by assigning suitable proportions to the steam cylinder and the pumps, or to the arms of the beam, they could raise the water to any required height.

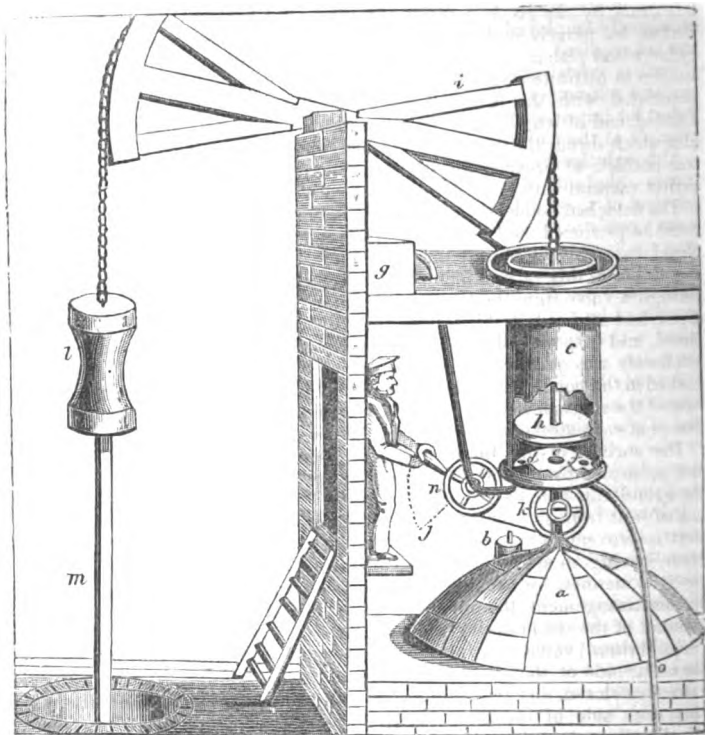
The figure on the following page (from an old engraving), will perhaps assist the reader's comprehension.

*a* represents the boiler; *b* the safety-valve; *c* the cylinder, open at the top, but closed at the bottom, in which there are three holes, *d e f*; *e* the passage for steam from the boiler; *d* admits a jet of cold water from the reservoir *g*, for the condensation of the steam; *f* the exit passage for condensed steam and water; *h* the piston, working air-tight in the cylinder, by packing; *i* the beam or loggerhead, for the purpose of transmitting the motion of the piston to the pumps in the mine.

A sufficient quantity of steam being first formed in the boiler, the attendant pushes the handle or lever which he holds down to *j*, which, by the wheels and band, opens the cock *k*, and allows the steam to enter the cylinder. The steam being only sufficient to equal the pressure of the atmosphere, will not of itself lift the piston and loggerhead; it is therefore necessary that some means should be adopted to aid its ascent. This is done by means of the weight or counterpoise *l*; so that by the force of the steam and gravity of the counterpoise, the piston is elevated to the top of the cylinder, and forces down the pump-rod *m* into the pump below. When this is effected, the attendant returns the handle to its original position (shown in the cut), which prevents the admission of more steam from the boiler, and, at the same time, opens the cock *n*, so as to admit a small quantity of cold water from the reservoir *g* into the cylinder; this, by dispersing itself among the steam, almost instantly condenses it, so that a void is at once obtained; and the pressure of the atmosphere meeting no longer with resistance, presses upon the external surface of the piston, and, by its descent to the bottom of the cylinder, raises the pump bucket in the mine. The handle is again depressed to *j*, which allows fresh steam to enter the cylinder and elevate



the piston as before. To prevent the accumulation of water in the cylinder, the eduction pipe *o* is of such length that the weight of a column of water



*Newcomen's Engine, 1705*

within it exceeds that of a column of the atmosphere; so that it runs off by its own gravity.

From the superiority of the principle of Newcomen's engine over Savery's it soon superseded the latter, and it came gradually into very general use for draining mines, receiving from time to time various important improvements in the mechanical details of the arrangement, from various ingenious persons, particularly the celebrated Smeaton. Our limits will not allow us to notice each of these as they occurred, we shall therefore proceed at once to the inventions of the great Watt, which completely altered the character of the engine, rendering it almost universally applicable, as a prime mover of machinery.

Prior to the introduction of Mr. Watt's improvements, the condensation of the steam in even the most improved arrangement of the atmospheric engine took place in the cylinder in which the steam operated, as it had done in its predecessor Savery's engine. The waste of fuel from this cause we have already pointed out, but in addition to this evil there was also a direct loss of power, owing to the vapour which was given out by the injection water, and which materially affected the vacuum. The attention of Mr. Watt was drawn to the subject about the year 1763. He was at that time a young man recently established in business at Glasgow, as an optician, and holding likewise the

appointment of mathematical instrument maker to the University of Glasgow, and, having to repair a small model of a steam engine belonging to the Institution, upon setting the machine to work after completing the repairs, he was struck by the great quantity of steam consumed by the engine: upon reflection he perceived that this was owing to the heat abstracted from the cylinder and piston at each stroke, during the formation of the vacuum. This led him to institute a series of experiments, in the course of which he became acquainted with the leading facts upon which the theory of latent heat is founded, and at length, after much patient investigation, he hit upon the grand idea which forms the basis of his fame—the separate condenser, whereby he was enabled to produce the desideratum he had been in search of, viz., a perfect vacuum with a hot cylinder.

The detached condenser consisted of a close vessel, in which a jet of water could be produced, and connected with the bottom of the cylinder by a pipe closed by a valve. During the ascent of the piston by the operation of the counterpoise, this valve remained closed, and the steam was admitted to flow through a valve from the boiler to the cylinder below the piston. When the piston had attained its highest point, the communication with the boiler was closed, and that with the condenser opened, and the steam rushing into the condenser was quickly condensed by a jet of cold water, and a vacuum established in the condenser and cylinder, causing the piston to descend by the pressure of the atmosphere. The air and injection water which collected in the condenser at each stroke were removed by an air-pump worked by the engine beam.

The success of this improvement realised his most sanguine expectations, and confirmed his opinion of the importance of maintaining the temperature of the cylinder as high as possible. With the view therefore of preventing the loss of heat from the exposure of the interior of the cylinder to the air, his next improvement was to exclude the air from the cylinder, by an air-tight cover, having an aperture for the passage of the piston rod, which worked in an air-tight manner, by means of a contrivance which he called the "stuffing box." In this arrangement, the upper side of the piston was continually exposed to the pressure of the steam during the working of the engine, and a valve called the "equilibrium" valve, was introduced, by which the steam could be admitted to the under side of the piston. During the ascent of the piston, the eduction valve was closed, and the equilibrium valve was kept open, and the pressure upon each side of the piston being thereby rendered equal, the piston was raised to the top of the cylinder by the action of the counterpoise. The equilibrium valve was then closed, and a vacuum being established within the cylinder by opening the passage to the condenser, the pressure of the steam upon the upper side of the piston carried the latter to the bottom of the cylinder. By this arrangement the engine became, in the strictest sense of the term, a "steam engine," depending in no way upon the pressure of the atmosphere, and constituting in fact, in its leading features, the pumping engine employed to this day in the mining districts.

The last grand improvement was the rendering the engine double acting, by causing the pressure of the steam to operate during the ascent as well as the descent of the piston; and to obtain a rotatory motion from the rectilinear movement of the piston. This may be considered the crowning improvement; from being limited almost exclusively to the purpose of lifting water, the engine became universally applicable as a prime mover, and its utility was increased a hundred-fold.

But it was not merely to the principles upon which the action of the engines depended that Mr. Watt confined his care; every part of the engine occupied his attention, and received improvement at his hands.

To give a detailed account of all these improvements as they rapidly succeeded each other, would far exceed our limits, we therefore refer the reader to the accompanying cut, which represents the engine in its matured state, with almost of the material improvements embodied.

$a$  the cylinder:  $c$  the stuffing-box, through which the piston rod passes. The stuffing-box consists of a short tube, cast upon the cylinder cover with a flanch

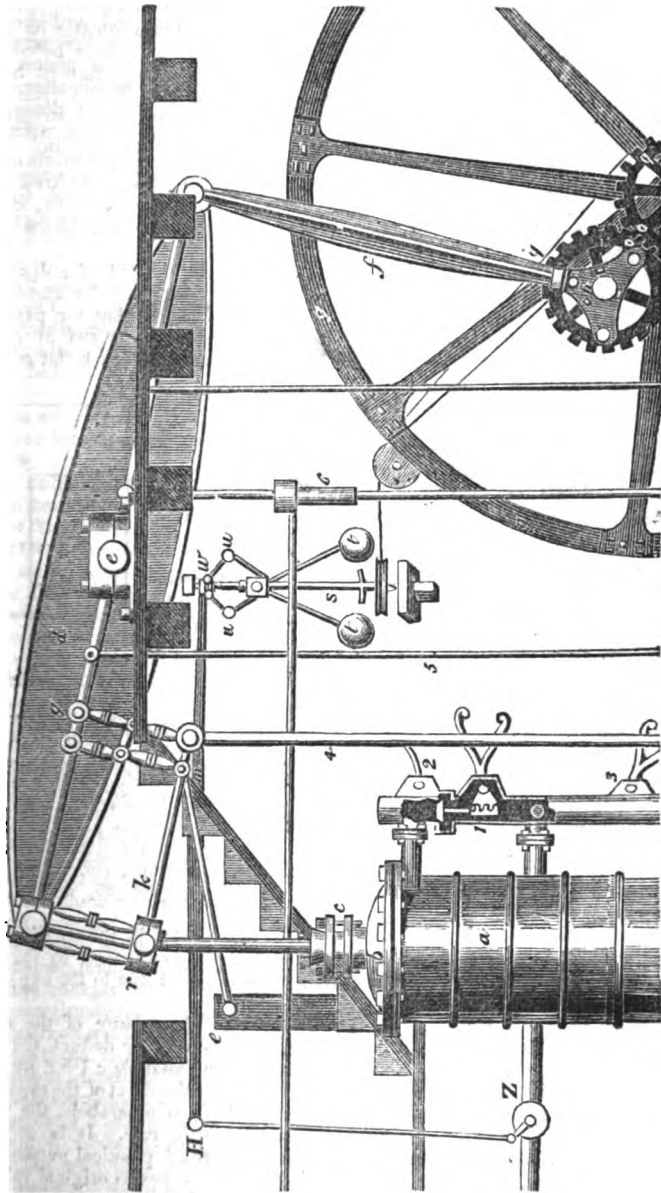
and screw-holes round its upper edge ; the interior is supplied with some soft substance (hemp or cotton) to surround the piston rod ; and upon the cover of the box is formed a ring or gland which fits into the box, and being screwed down upon the stuffing, presses it closely round the piston rod, and thereby prevents the escape of the steam from the cylinder. *d* is the working beam, resting upon its centre *e*, and connected at one end to the piston rod, at the other to the bar *f*. To the cylinder *a* (which, in this modification, has no external jacket) is attached a tube, through which the steam is allowed to pass above and below the piston, through the pipe *Z*, connected with the boiler ; in this tube are placed valves, one above and one below the point of junction with *Z*, which are moved by external levers. Now, supposing the blowing-valve to have been opened, and the vacuum formed in the condenser in the manner before described, the steam rushing through the upper elbow of the tube upon the piston, forces it to descend to the bottom of the cylinder ; by this action the lever *l* is turned downwards, by means of tappets placed on the pump rod *4*, and shuts that valve ; whilst *2*, on a pipe behind that which we see, opens a passage to the condenser. The lever *3* is at the same time opened, admitting steam under the piston, which consequently ascends. *5* is a rod connected with the discharging-pump attached to the condenser ; *6* a small pump, which supplies the boiler with heated water from the condenser.

The vertical descent of the piston rod (through the stuffing box) by its attachments to the beam, is explained in the article **PARALLEL MOTION**, and need not here be repeated.

Mr. Watt had employed the fly-wheel, in order to equalize the motion of the piston in the cylinder (see article **FLY**) ; but as it became an important object to convert the alternate motion into a rotary one, he applied himself to the discovery of a ready means of effecting it. The crank (see article **CRANK**) could have been appropriated to this purpose ; but a patent was at that time in force for the exclusive adaptation of it by another ; and as some dispute had arisen upon the subject, Watt was compelled to resort to some other mode, by which a similar effect might be achieved, without the invasion of another's privilege. This ended in the construction of what is now known by the name of the *Sun-and-Planet* wheels, the action of which is as follows :—the bar *f* (an inflexible rod) is attached at one end to the working beam, and at the other to *k*, a toothed wheel that can revolve upon its axis ; *o* is likewise a toothed wheel fixed to the fly. As the beam rises the planet wheel *k* is drawn up on the circumference of the sun wheel, and turns it round, causing the sun wheel to make two revolutions while the planet wheel travels once over its circumference ; the momentum of the fly being sufficiently powerful to preserve the tendency of the machinery to revolve in the same direction during the change of motion in the piston, and to urge the planet wheel over the inactive points in its circuit, the continued rotary motion becomes at once effected, and with this advantage, that as the fly makes twice the number of revolutions it would make by the common crank, a lighter body of material composing the fly is required. There are, however, several disadvantages attending this mode of converting an alternate into a rotary motion, such as being more complex, expensive, and liable to derangement.

One of the last improvements made by Watt upon his engines was the application of a fine piece of mechanism which had been previously used for other objects—the *governor* or regulator. The invention has been ascribed, but improperly, to Watt ; and although it is said that the notion of applying it to steam engines was first suggested by a Mr. Clarke of Manchester, it does not appear that he ever carried it into practice. The governor *s* is composed of two balls, fixed each to a lever attached to other and shorter levers, *u u*, above the point of junction, the latter being fixed by a moveable joint to a slider, *w*, moving freely on the vertical rod *s*. The horizontal lever *v H* has a fulcrum, and raises or lowers another lever *H Z*, which is attached to a valve inside the steam-pipe at *Z*. On the pulley *z* is a cord *q* proceeding from the fly-wheel ; by this means a rotary motion is given to the vertical rod, and the balls by their centrifugal force (*vide* article) rising outwards, draw downwards the slider ; which movement

raises the opposite end of the horizontal lever H, which acting on the lever connected to it, opens or shuts (as it may be adjusted) the valve Z inside the:



steam pipe, and diminishes or enlarges the area by which the steam flows into the cylinder. The fall of the balls when the motion decreases, reverses all

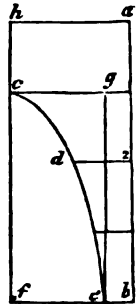




these movements, of course; and by thus enlarging or contracting the steam-way, and admitting more or less steam into the cylinder, the impulse of the piston is rendered much more uniform. The valve in this part of the steam-pipe is now called the *throttle valve*, and the regulating pendulum the *governor*.

An important improvement of Mr. Watt's was carried into practice in 1778. It consists in shutting off the steam from the cylinder, some time before the piston has completed its stroke, so that the remainder may be performed by the expansion of the steam already contained in the cylinder. This serves as a method of regulating the acting force of the engine, because, as the steam can be shut off at any part of the ascending or descending stroke, so much steam may be admitted as barely to carry the piston through its required motion, and by the adjustment of the valve gear, the quantity of steam admitted may at all times be varied in an instant. If this were the only advantage, it is a great one; but it will be seen that a great saving of fuel will likewise be effected by this method.

We shall endeavour to explain this more clearly by the aid of a diagram. The pressure of steam, as ascertained by numerous and carefully conducted experiments, is so nearly in direct proportion to its density, that for practical purposes it may be assumed to be in that ratio; and its density is of course inversely as the space occupied by it. Having premised thus much, let  $a l c h$  represent a cylinder into which the steam flows during the whole period of the stroke; at the end of which, or when the piston arrives at  $l c$ , the steam is discharged from the cylinder; then the effect being as the pressure of the steam multiplied by the space through which it acts, which pressure is in this case the same throughout the stroke, if the line  $a h$  represents the pressure, and  $a l$  the space through which it acts, the area of the rectangle  $a l c h$  will represent the effect.



Now let  $a b f h$  represent another cylinder of the same diameter as the former, but four times as long, and let it be supposed that only the same quantity of steam is admitted as before, the steam being cut off when the piston has reached to the position  $c l$ , which is only  $\frac{1}{4}$  of the stroke in the cylinder  $a b$ ; the piston will in this case continue to descend, but the pressure upon it will gradually decrease; and when the piston has made half its stroke, as the original volume of steam  $a l$  will then be expanded into double its bulk, or occupy the space  $a 2$ ; its density, and consequently its pressure, will only be half as great as at the moment at which it was cut off, or when the piston was in the position  $c l$ ; therefore if the line  $c l$  represent the full pressure of the steam, the line  $d 2$  will represent its pressure at the position 2. At the end of the stroke, or when the piston arrives at  $f b$ , the steam will be expanded into four times its original volume; consequently its pressure will then be only one fourth of its original pressure, and will be represented by the line  $b e$ .

In this case the total effect of the steam will be represented by the area  $h c e b l a$  which exceeds the effect of the steam in the first supposed case, by the area  $c d e b l$ , which therefore represents the increase of power due to the expansive action of the steam.

The curve  $c d e$  represents the ratio in which the pressure of the steam decreases as the piston descends in the cylinder, and if we deduct the area included by the points  $c d e f c$ , from the area of the rectangle  $c l b f$ , we shall obtain the area of the figure  $c e b l$ , which represents the effect of the expansive action. Now, as the curve  $c d e$  differs but little from a parabola, the mean pressure may be readily computed by the following rule. It is only an approximation, but it is sufficiently near the truth for all practical purposes, so long as the steam does not expand to more than four times its original volume, and within those limits gives a result rather below the true one.

**RULE.**—To the pressure of the steam, above the pressure of the atmosphere, add 15 lbs per square inch for the atmospheric pressure, and call the sum the

total pressure of the steam; square the fraction of the stroke during which the steam acts expansively, and deduct  $\frac{1}{10}$  of the product from unity, and the remainder, multiplied by the total pressure, will be the mean pressure, after deducting 15 lbs for the pressure of the atmosphere in the case of non-condensing engines.

Example in a non-condensing engine; suppose the pressure of the steam, at the commencement of the stroke, to be 45lbs per square inch above the atmosphere, and that the steam is cut off at  $\frac{1}{4}$  of the stroke: required, the mean pressure of the steam.

First.	Full pressure . . . . .	45 lbs
	Atmosphere . . . . .	15 ..
		60 lbs
		60 lbs
Then.	Steam cut off at $\frac{1}{4}$ . . . . .	.25 ..
	Expands throughout $\frac{1}{4}$ . . . . .	.75 ..
	Which is to be squared . . . . .	.75 ..
		375
		525
		5625
	Deduct $\frac{1}{10}$ . . . . .	.7
		39375
	From unity . . . . .	1.
		60625
	Multiply by total pressure . . . . .	60 lbs
		3637500
	Deduct for atmospheric pressure . . . . .	15
		3637500
	Mean pressure . . . . .	21.375 lbs

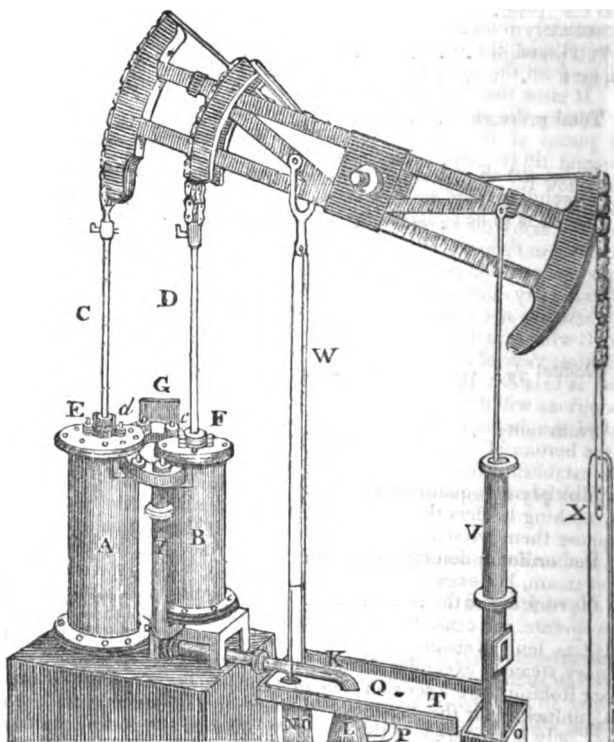
The mechanical effect being as the pressure of the steam, and the space through which such pressure is exerted, the effect of the steam whilst acting at full pressure in the above example, will be as 45lbs through a space 1=45, but the total effect will be as 21.375lbs through a space 4, which is equal to 85.5, or nearly double the former, and shows the great advantage to be derived from using steam expansively. There are, however, in practice certain limitations to the extent to which steam may be allowed to expand, for independently of the inconvenience of the great size of the cylinder when the expansion is carried to an extreme, the pressure of the steam upon the piston should never be less than the resistance from the friction, &c. added to the pressure of the atmosphere in non-condensing engines, or the pressure of the non-condensed steam in condensing engines; but in the preceding example, the pressure at the end of the stroke is merely equal to that of the atmosphere. Mr. Tredgold gives the following rule for ascertaining the point at which the steam should be cut off, so as to produce the greatest effect:—

Divide the amount of the friction, &c. added to the pressure of the atmosphere, in non-condensing engines, or of the non-condensed steam of condensing engines, by the pressure of the steam in the boiler, and the quotient will give the proportion of the stroke at which the steam should be cut off.

Example.—The pressure of steam in the boiler being equal to 120 inches of mercury, the loss from friction, &c. (reckoned as  $\frac{1}{2}$  of the whole) is 48, which added to 30 inches for the pressure of the atmosphere is 78, and this divided

by 120 gives  $\frac{M}{120}$  as the part of the stroke at which the steam should be cut off.

The principle of expansion was subsequently adopted by Hornblower, who in 1781 obtained a patent for an expansion engine, arranged as exhibited in the accompanying cut, of which the following is a description extracted from the *Encyclopædia Britannica*.



Let A and B represent two cylinders, of which A is the largest; a piston moves in each, having their rods C and D moving through collars at E and F. These cylinders may be supplied with steam from the boiler by means of the square pipe G, which has a flange to connect it with the rest of the steam-pipe. This square part is represented as branching off to both cylinders; c and d are two cocks which have handles and tumblers as usual, worked by the plug-beam W. On the fore side of the cylinders is represented another communicating pipe, whose section is also square, or rectangular, having also two cocks, a b. The pipe Y immediately under the cock b establishes a communication between the upper and lower parts of the cylinder B, by opening the cock b. There is a similar pipe on the other side of the cylinder A, immediately under the cock a.

When the cocks c and a are open, and the cocks b and d are shut, the steam from the boiler has free admission into the upper part of the small cylinder B, and the steam from the lower part of B has free admission into the upper part of the great cylinder A; but the upper part of each cylinder has no communication with its lower part. From the bottom of the great cylinder proceeds the eduction pipe K, having a valve at its opening into the cylinder; it then bends

downwards, and is connected with the condenser. Lastly, the pump-rods cause the outer end of the beam to preponderate, so that the quiescent position of the beam is that represented in the figure, the pistons being at the top of the cylinder. Suppose all the cocks open, and steam coming in copiously from the boiler, and no condensation going on in L, the steam must drive out all the air, and at last follow it through the valve Q. Now shut the cocks *b* and *d*, and open the escape-valve of the condenser; the condensation will immediately commence, and draw off the steam from the lower part of the great cylinder. There is now no pressure on the under side of the piston of the great cylinder A, and it immediately descends. The communication Y between the lower part of the cylinder B, and the upper part of the great cylinder A being open, the steam will go from the lower part of B into the space left by the descent of the piston A. It must therefore expand, and its elasticity must diminish, and will no longer balance the pressure of the steam coming from the boiler, and pressing above the piston of B. This piston, therefore, if not withheld by the beam would descend till it came in equilibrio, from having steam of equal density above and below it. But it cannot descend so fast, for the cylinder A is larger than B, and the arch of the beam, at which the great piston is suspended, is no longer than the arm which supports the piston of B; therefore, when the piston of B has descended as far as the beam will permit, the steam between the two pistons occupies a larger space than it did when both pistons were at the top of their cylinders, and its density diminishes as its bulk increases. The steam beneath the small piston is, therefore, not a balance for the steam on the upper side of the same, and the piston B will act to depress the beam with all the difference of these pressures.

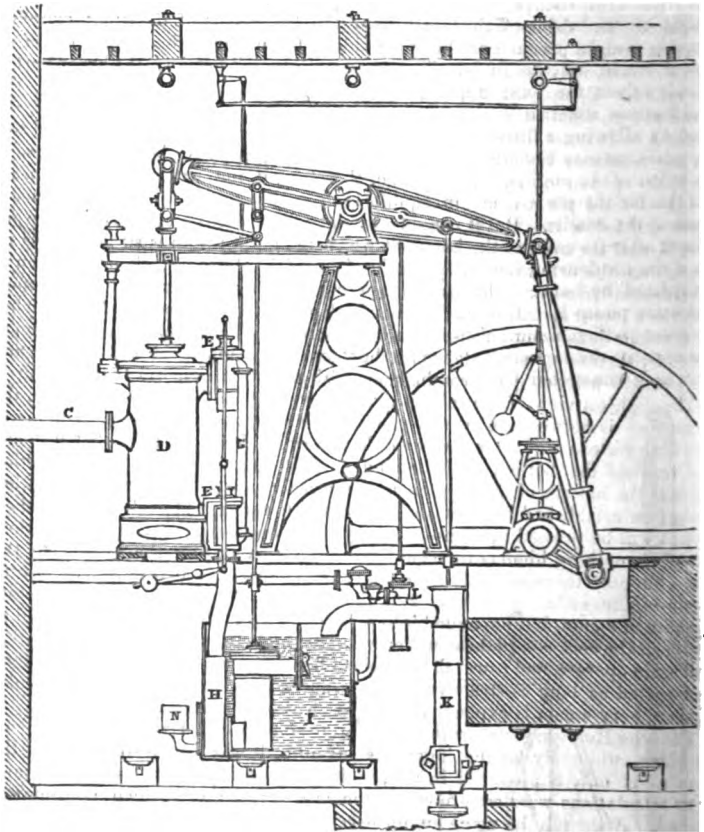
The slightest view of the subject must show, that as the piston descends, the steam that is between them will grow continually rarer and less elastic, and that both pistons will draw the beam downwards. Suppose, now, that each one had reached the bottom of its cylinder: shut the cock *a*, and the eduction valve at the bottom of A, and open the cocks *b* and *d*. The communication being now established between the upper and lower part of each cylinder, their pistons will be pressed equally on the upper and lower surfaces; in this situation, therefore, nothing hinders the counter-weight from raising the pistons to the top. Suppose them arrived at the top: the cylinder B is at this time filled with steam of the ordinary density, and the cylinder A, with an equal absolute quantity of steam, but expanded into a larger space. Shut the cocks *b* and *d*, and open the cock *a*, and the eduction valve at the bottom of A, the condensation will again operate, and cause the pistons to descend; and thus the operation may be repeated as long as steam is supplied; and one measure full of the cylinder B of ordinary steam is expended during each working stroke.

Professor Robison gave a series of elaborate and highly interesting calculations, by which, unluckily for the ingenious inventor, it was demonstrated, that the same effect only is produced in this, as in Mr. Watt's expansion engine; and these calculations were confirmed by the practice of those which Hornblower erected. Although he made an unsuccessful application to Parliament for an extension of the term of his patent, it does not appear that his engine obtained public patronage or approbation.

After the expiration of Watt's patent, the condensing engine, under the hands of different manufacturers, assumed a variety of forms. The accompanying cut represents a portable engine of 12 horse-power, as constructed by Messrs. Rothwell, Hick, & Rothwell, of Bolton.

This engine consists, in the first place, of a large cast-iron plate, firmly bolted to stone or brick-work, on which the whole of the materials are fixed. The beam with all its appendages is by this means supported, without being at all connected with the building, by a double diagonal frame, one half surmounted by an entablature plate, to which the bearers or spring beams are attached, that receive the studs or centres of the radius rod of the parallel motion, the extreme ends of which are supported by a pillar resting on a bracket projecting from the back of the cylinder. The pedestals in which the gudgeon of the beam works, rest on the entablature plate, and are firmly secured by bolts passing through the whole. The side walls on which the foundation plate acts are so

far asunder as to allow a sufficiently wide recess to receive the condensing cistern, with its air-pumps and condenser, hot and cold water pumps, as well as to afford room for getting down to secure the ends of the bolts. The governor is supported by a standard placed directly over the crank shaft, and is turned by a single pair of bevel wheels. The upper part of it is hollow, to receive a small



rod, that is attached by a cross pin to a brass sliding socket, which is connected with the governor arms by two small links, and partakes of the motion communicated to them by the movement of the balls. The small rod has a communication with the throttle-valves, by means of the levers fixed to the ceiling of the engine-house.

The kind of boiler attached to this engine is of the waggon-shaped kind, a full description of which has already been given at page 198 of the first volume of this work.

The steam cylinder and its casing are cast together in one piece; the space betwixt them is constantly filled with steam, which prevents any condensation taking place within the cylinder, and serves also as a conducting-pipe for the steam to the boxes E, containing the sliding valves, (which are generally called D valves, from their resemblance in form to that letter,) through two separate openings for that purpose, in each of which is placed a throttle-valve, and on

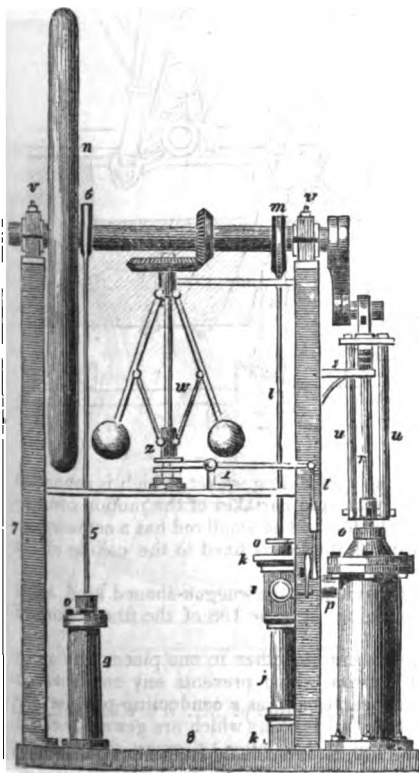
their spindles are levers, communicating by a rod with the governor, for regulating the speed of the engine.

The sliding-valves are packed on their circular sides with a soft substance of hemp or flax, and in consequence of the steam being admitted to the under side of the top valve, and the upper side of the bottom valve, they of course require no more force to move them than what is necessary to overcome the friction of the packing, and the surface over which they slide. The weight of the valves and their rods are accurately counterbalanced by a movable weight or a lever under the cylinder, and are moved by an eccentric circle, on the fly-wheel shaft. By the arrangement of having two throttle valves, the least difference in weight between those parts of the engine that are attached to the opposite ends of the working beam can be regulated, by allowing a little more steam to pass in the same time through either of the valves, as may be found necessary,—thereby equalising, as much as possible, the action of the engine. One pipe, G, only is required in front of the cylinder, and that for the purpose of conducting the steam from the upper side of the piston to the condenser. H, a vessel in which the condensation of the steam is effected after its escape from the cylinder, by admitting a quantity of cold water out of the condensing cistern I, through an injection cock, the opening of which is regulated by hand. The condensing cistern is supplied with water by the cold water pump K. L is the hot water pump, used for raising water to supply the boiler; which water passes through a small valve, and down the same pipe that contains the damper-float. This valve is connected with a lever, having one of its ends connected by a rod passing through a pipe with a stone float, that

rises and falls with the surface of the water in the boiler, and thereby admitting a smaller or larger quantity of water, as may be requisite. This pipe, for the rod to pass through, has several advantages over the method of passing it through a stuffing-box on the boiler top; as, in case the hot water pump by any accident should cease to act, and the water get low in the boiler, the steam would make its escape before any serious injury could happen,—showing instantly that such was the fact, the moment it got below the end of the pipe. The friction between the rod and the water being so trifling, insures an almost uniform regularity of action. N, a small cistern, containing the blow-valve, for the purpose of allowing the air to escape from the cylinder, &c., previous to the engine being set to work.

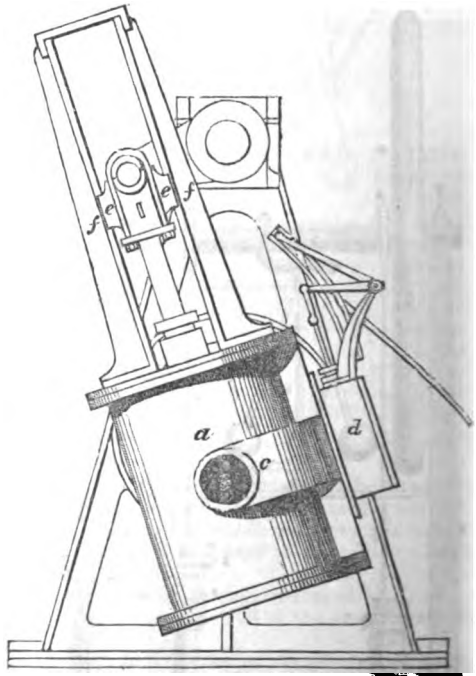
We shall now give an example of a common arrangement of the high pressure engine; in which, as no air pump is required, the beam is dispensed with.

h, the steam-pipe leading from the boiler, in which is the throttle-valve i; j, the



side-pipe, in which work the slide-valves *kk*, moved by the rod *l*, attached to the eccentric *m*, on the shaft of the fly-wheel *n*. *ooo* are brass stuffing-boxes; *p*, the upper steam entrance to the cylinder; *qr*, the piston-rod working through the bridge *s*, and communicating with the crank *t* by the side-rods *u u*,—forming a very simple parallel motion; *v v*, pedestals supporting the main shaft, the revolution of which gives motion to a pair of bevel wheels, and thereby to the governor *w*, the expanding or contracting of the arms of which raises or depresses the collar *x*, and acts on the valve *i* through the medium of the lever 1 and handle 2; 4 is the pump for supplying the boiler through a feed-pipe (not shown) worked by the rod 5, and eccentric 6; 7 7 are the metal cheeks of the frame; 8, the metal foundation plate, under which is a small cistern, (not shown,) containing a day's consumption for the boiler. At the bottom of the side-pipe is an eduction-pipe, (not shown,) from which the steam is discharged into the cistern, to heat the water for supplying the boiler after the steam has performed its office in the cylinder. The periphery of the fly-wheel is round in its transverse section, and of cast iron; the arms or radii are of wrought iron, and are inserted into the former while casting.

The subjoined figure represents an arrangement which is frequently adopted for engines of small power; the cylinder is suspended upon axes or gudgeons, and vibrates to and fro during the revolution of the crank, and hence these engines are commonly called vibrating engines. The gudgeons are hollow, and form the steam and eduction pipes; *a* is the steam cylinder, *b* the hollow gudgeon at which the steam enters, and whence it passes by the channel *c* to the slide case *d*; and a channel similar to *c* connects the eduction passage with the other gudgeon, which opens into the condenser. The gudgeons project beyond the bearings in which they work; and their extremities pass through stuffing-boxes in the steam pipe and condensers; no connecting rod is required, but the piston rod is connected directly with the crank pin, and during the revolution of the crank the cylinder vibrates upon its gudgeons through an arc proportioned to the length of the crank. To the head of the piston rod is fixed a cap *ee*, which works between the guides *ff*, which are bolted to the cylinder cover, and thus take the strain off the piston rod in the oblique positions of the cylinder, and as the cylinder can be nearly counterbalanced on its axes in all positions, the strain upon the piston rod is never considerable.

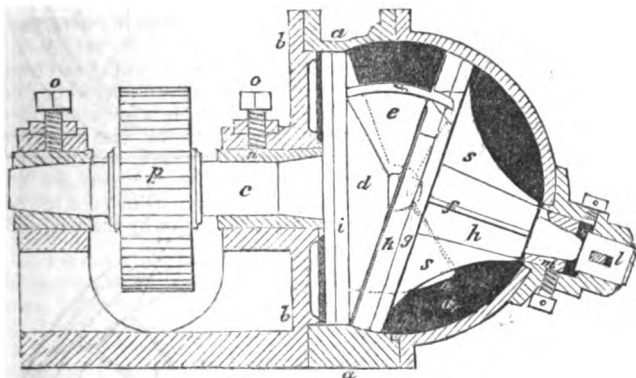


This arrangement is, we believe, the invention of Mr. Witty of Hull, who obtained a patent for it June 5th 1813.

Partly from the erroneous notion that is extensively entertained, that there is a loss of power in the employment of the crank to transmit the power given

out by the piston, and partly from the advantages which would in certain purposes result from a circular motion of the piston upon which the steam impinges. A rotatory engine has long been regarded as a desideratum by numerous theoretical and practical mechanics, and many plans have been devised and some brought into partial operation for that purpose: from amongst these, we select a few of the most remarkable.

*Ericsson's Disc Engine.* The accompanying figure represents a rotatory engine invented by Captain Ericsson, which, although difficult to describe, so as to convey a clear idea of the way in which it operates, is alike remarkable for the fewness of its parts and the simplicity of its actions. It has no valves, the action of the piston upon the driving shaft is at all times direct, and the engine can be started or reversed at any position of the piston. *a a* is a spherical chamber formed



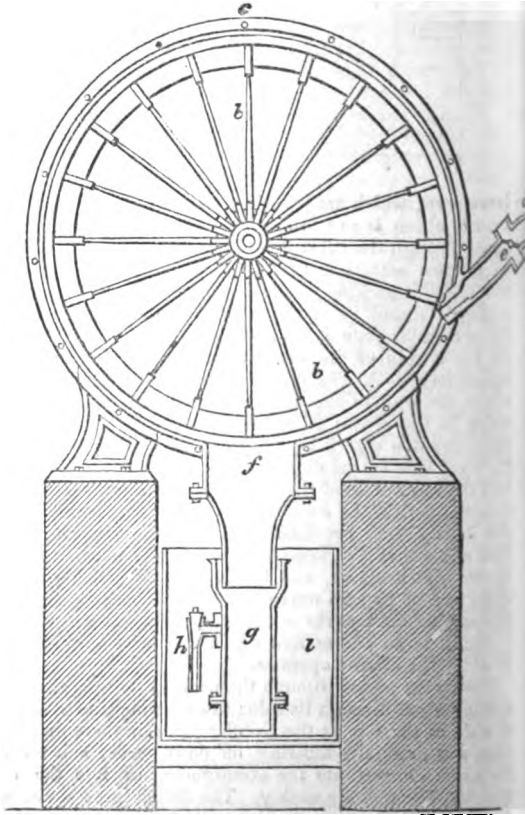
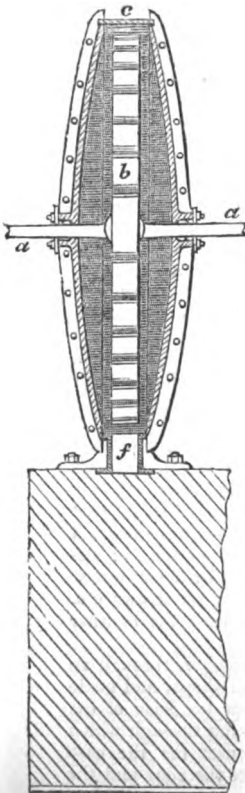
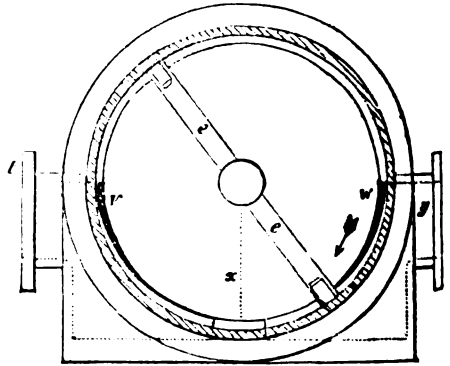
in two parts, which are joined together by flanges, and bolted to an end plate or cover *b*, which is cast in one with the bed plate; *c* is the engine shaft, which passes through the cover *b*, and has an obtuse cone *d* firmly fixed upon its end. *e e* are two sectors or fans, fixed on to the cone on opposite radii, and fitted with metallic packing *f* in their curved side: the cone *d* likewise has metallic packing *i* round its circumference. The sectors *e e* pass through slits *r* in a disc or circular plate *g*, the lower side of which is forced into close contact with the lower side of the cone, by means of a brass bearing *l*, which presses against its axis *h*. The disc is retained securely in its position by a spherical nob on the end of the engine shaft, which works in a corresponding cup or socket in the centre of the disc; and the revolution of the shaft causes the disc to revolve with it by the pressure of the sectors on the sides of the slits, the lower side of the disc remaining throughout the revolution in close contact with the lower side of the cone. The slits in the disc gradually widen upwards to accommodate the continually varying angle which the sectors form with the disc during their revolution together, and to prevent the escape of steam past their edges they are lined with a metallic packing *r*; the disc is strengthened by thin flat arms *s s*, and has a metallic packing *k* round its periphery; the upper end of its axis works in a conical bearing *m*, governed by a set screw. The engine shaft works in conical bearings at *n n* governed by set screws *o o*.

*Fig. 2.* is an end section which will serve to show more clearly the manner in which the engine operates.

The steam passes through the neck *t* into the spherical chamber, through an opening *o* cut through its side: this opening is of a triangular shape, and made as wide at the top as the circular plane is there distant from the base of the cone, and gradually tapering off downwards; *w* is the opening through which the steam escapes into the atmosphere, or into the condenser (as the case may be), through the neck *y*. The dotted line *x* shows where the cone and the circular plane come in contact.



Steam being admitted into the spherical chamber by the neck *l* and opening *v*, and being there prevented from passing the line *x* by the pressure of the disc against the cone at that place, it presses against the upper leaf *e*, which, together with the cone and disc, is thereby carried round in the direction of the arrow. When the leaf has passed the upper part of the opening *w*, the steam that has been acting upon it escapes into the condenser, or into the atmosphere; but at the same time the opposite leaf has passed the top of the steam opening *w*, which is carried round in a similar manner, and thus the motion is continued.



CORDER AND LOCKE'S ROTATORY ENGINE.

If it be requisite that the engine should be capable of working with a reverse motion, this may be effected by reversing the inlet and outlet passages of the steam, by means of a four way cock, or a common slide valve.

*Corder & Locke's Breast-wheel Steam Engine.*—This machine is extremely simple in its construction, having neither piston nor valves, nor, in fact, any rubbing parts save the axle in its stuffing-boxes and bearings. According to the statement of Mr. Josiah Parkes, C. E., who was appointed to examine and report upon the performances of the engine, it is fully equal in effect to cylinder condensing engines consuming the same quantity of fuel. Mr. Parkes further states, that if applied as an auxiliary to a condensing cylinder engine, by causing the eduction steam from the latter to pass through the rotatory engine before it arrives at the condenser, that an additional power equal to one third of the power of the cylinder engine is obtained without any additional cost in fuel, or increase of the air pump or condenser.

This engine consists principally of a wheel, revolving in an air-tight case, in open communication with a condenser, and provided with air pumps, for keeping up an exhaustion within the case.

The wheel is somewhat like an overshot water-wheel, and does not touch any part of the case. It is turned by a jet of steam issuing from the steam-pipe of the boiler, into the exhausted case, through a tube, which is inclined in the direction of a tangent to the circumference of the wheel, so that the steam impinges against the buckets of the wheel and turns it round with great rapidity. The shaft of the wheel passes through stuffing-boxes at the centre of the circular case, and is supported externally by bearings.

The motion for the air-pumps is obtained from a small double-acting steam cylinder, independently of the rotatory engine.

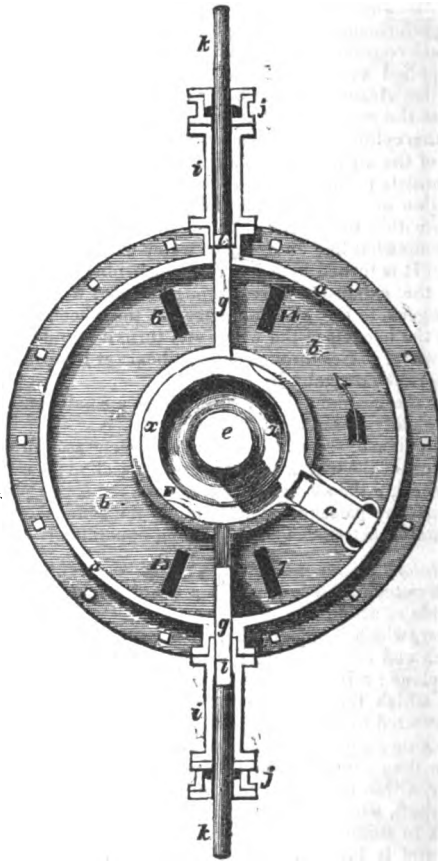
*Fig. 1* is an end view of the wheel, and a transverse section of the case, and *Fig. 2* is a side view of the wheel, with the case in section; *a* is the engine shaft, *b* the revolving wheel, *c* the air-tight steam cases, *d* the steam pipe, *e* the throttle valve, *f* the exhausting passage, opening into *g* the condenser, *h* the injection cock, *i* the cold water cistern. The exhausting apparatus is not shown.

*Galloway's Rotatory Engine.*—The annexed *Fig.* represents a transverse section of the engine, divested of such parts as are not required to explain its construction and mode of action.

*a a* is a cylinder, which is supported upon a frame (not shown in the figure), and closed at each end by a cover *b*, the internal surface of which is faced so as to be a true plane; *x* is a smaller concentric cylinder, into which is keyed the shaft *e*, and which therefore revolves with the shaft; *c* is a rectangular piston firmly connected to the smaller cylinder *x*, and furnished round its sides with metallic packing; *g g* are two sliders moving in steam tight cases *i*, and in rebates formed in the cylinder covers; they form the steam abutments, and are drawn alternately within the slide cases, to allow the piston to pass by means of a cam on the shaft, which operates on cross heads attached to the slide rods, which latter work in stuffing-boxes. After the passages of the piston the upper slider descends, and is brought to rest upon the revolving cylinder *b* by its own weight; the lower is pressed against the cylinder *b*, by a counterpoise: 6, 7, 13, and 14, are the passages by which the steam enters the cylinder, and passes off to the condenser, or the atmosphere, as the case may be. These passages are connected with a steam chest, attached to the frame of the engine, and furnished with a common slide valve, for the purpose of reversing the engine, as will be hereafter explained.

In order to put this engine in motion, we will suppose that the slide in the steam chest is so arranged that the valves 6 and 7 are the induction valves, and 13 and 14 the eduction valves. The piston being in the position shown, the valve 14 is then open to the condenser, and the valve 7 to the boiler, and the steam rushing in between the upper slider, (which then forms the abutment) and the piston, forces round the latter in the direction of the arrow. As soon as the piston has passed the lower slider, the cam on the piston shaft recedes from the cross head of the lower slider, and the slider is gradually forced up by its

counterpoise until it comes in contact with the shaft; the piston will then be at G and both sliders shut, and only the two valves 7 and 14 open. As the piston continues to revolve, the cams gradually open the upper slider and the valve 13, and gradually close the valve 14, so that when the piston reaches the valve 13, the former is completely shut, and the latter completely open, and when the

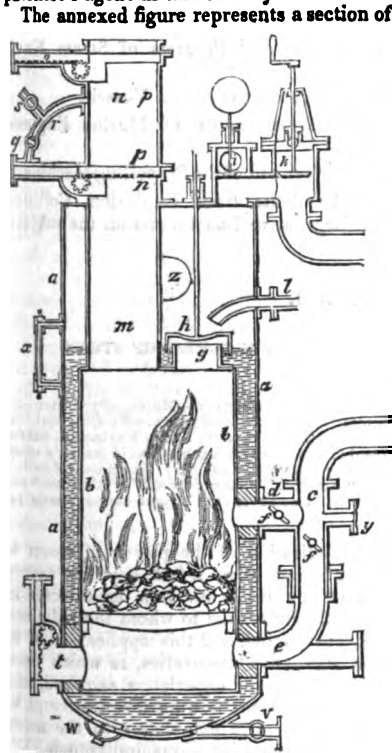


GALLOWAY'S ROTATORY ENGINE.

piston reaches the upper slider, it is completely withdrawn from the cylinder, and thereby allows the piston to pass it. At this point, the steam is entering through 6, and escaping through 13, the lower slider being then the abutment upon which the steam acts. After the piston has passed the upper slider, the cam allows the piston gradually to return to its place in the cylinder, and after the piston has passed the valve 6, that valve begins gradually to open, and the valve 7 to close. Therefore when the piston has reached the pipe, the upper slider is in its seat in the cylinder, the valves 7 and 14 are quite shut, and 6 and 13 quite open: the cam 4 then begins to give motion to the lower slider as before described, and the cam 10 to the valves, so that a constant rotation of the axis is kept up.

To reverse the motion of this engine, the sliding valve in the steam chest is moved in its face, so that the valves 6 and 7 become the eduction valves, and 13 and 14 the induction valves.

*Bennett's Steam and Smoke Engine.*—Oliver Evans, the celebrated American mechanic, projected an engine, which he termed a *volcanic engine*, wherein he proposed to combine the expansive force of the heated gases and other products of combustion with that of steam. Subsequently the idea has been embodied in several patents in this country: we select one of the most recent for illustration. The patent was taken out in the name of Mr. Hawkins, the patentee's agent in this country.



The annexed figure represents a section of the boiler. *a a* is a vertical cylinder constituting the shell of the boiler, *b b* a smaller cylinder placed within the former, and forming the furnace and ash pit: this is entirely surrounded with water. *c* is a tube connected with a blowing machine, and having two branches *d* and *e*, the former of which admits a portion of air above the fuel, and the latter a portion into the ash-pit, below the fire-bars: two throttle valves or dampers *ff* are provided to regulate the draft through each branch. *g* is a short cylindrical neck, through which the smoke and heated air pass into the steam-chamber, where they mix with the steam, and with it pass to the working cylinders. The neck *g* is covered with a valve *h*, opening upwards, the sides of which are turned down, to cause the heated air to pass through the water, and thereby give out a portion of its heat to the water: *i* the safety valve, *k* valve by which the pipe that conveys the steam to the engine can be closed when required, *l* the pipe by which the water is conveyed to the boiler, from the feed pump; the end of this pipe enters the boiler, and delivers the water on to the top

of the valve *h*; this is with a view to prevent the valve getting excessively heated by the action of the fire. *m*, is the chimney, or rather passage by which the fuel is introduced into the furnace; on it is bolted a hopper *n n*, having at its upper end a flat plate or sliding valve *o*, and another valve *p* at its lower end; these valves slide in grooves, and are moved by means of a rack and pinion; they are ground on their seats so as to form an air-tight joint, and during the whole time the engine is in operation, the chimney is kept closed by one or other of these valves. To kindle the fire before starting, the valves *o* and *p* are both opened, and a quantity of lighted fuel put in first through the hopper, and fresh fuel heaped upon it, and when the whole is thoroughly ignited, the valve *p* is closed, and the blowers set in operation. When the engine is set to work, it forces a quantity of air into the furnace both above and below the fuel at each stroke, which having no vent to escape but the valve *h*, accumulates in the furnace until its pressure somewhat exceeds that of the steam upon the valve *h*, when it lifts the valve, and rising up through the water mixes with the steam,

and passes along with it to the engines.  $t$  is a slider, by opening which the ashes from the furnace can be withdrawn; when this is requisite the dampers  $ff$  must be first closed.  $v$  is the blow-off cock by which the water can be discharged from the boiler when required, and  $w$  is a hole covered by a door, for removing any mud, &c. which may have accumulated: at  $x$  is a glass gauge to show the height of the water in the boiler, and at  $y$  is a glass eyepiece, through which the state of the fire can be ascertained, and  $z$  is the man-hole by which admission is obtained into the boiler.

**STEAM NAVIGATION**, the navigating or propelling vessels by steam.—In treating this subject we have, for the sake of perspicuity, and for ease of reference, divided it into the following sections:—

**SECTION I.**—Historical Outline of the Rise and Progress of Steam Navigation.

**SECTION II.**—The construction and arrangement of Steam Vessels.

**SECTION III.**—The construction and arrangement of Marine Engines, Boilers, Condensers, &c.

**SECTION IV.**—The construction and arrangement of the Propelling Machinery.

**SECTION V.**—On the Prevention of Accidents from Explosion, Collision, Fire, Foundering, &c.; with the Legislative Enactments on the subject

## SECTION I.

### HISTORICAL OUTLINE OF THE RISE AND PROGRESS OF STEAM NAVIGATION.

Early writers and projectors; Dr. Allen.—Hulls.—Fitch.—Rumsey.—Miller.—Syrington—his first Boat—his second, the "Charlotte Dundas."—Fulton.—Livingstone.—Fulton's boat, the "Clermont."—First voyage by steam.—Fulton not the inventor of Steam Navigation, but the first who established it.—Ordinary arrangement of Scotch steam boats.—David Napier's steam packet.—The "Enterprise's" voyage by steam to Calcutta.—Auxiliary Steamers.—Melville's auxiliary propellers applied to the "Maria," "Emerald," "Sarah Sands," "Amphion," and "Arrogant" steam frigates. Table of dimensions of some of the largest steam vessels yet constructed.

From the immense importance of the application of the power of steam to the purposes of navigation, the honour of originating it has been as keenly contested as the invention of the steam engine itself, and it is as difficult in the one case, as in the other, to fix upon the individual to whom the palm can be justly awarded. In fact, both the steam engine, and this application of it, must each be considered as the result of successive discoveries, to which even unsuccessful attempts contributed something, by the experience acquired, and various phenomena they brought to light. We shall not, however, attempt to notice every obscure hint and crude suggestion on which claims to the merit of the invention have been advanced in favour of various individuals, but shall briefly advert to some of the leading facts in the rise and progress of this most important invention.

The first clear and distinct announcement of a practical plan for propelling vessels by steam of which we are aware, is contained in a work entitled, "Specimina Ichnographica, or a brief narrative of several new inventions," which was published by a Dr. John Allen in 1730. The first chapter describes various plans for economising fuel, by placing the furnace and fires within the boiler, so that they should be surrounded by water, as in the boilers of steam vessels of the present day. The second chapter contains a plan for moving ships in a calm. The Doctor notices several inventions which had previously been proposed for the purpose, and observes that in them "the motion was communicated by machinery working *without* the ship, something analogous to oars or paddles, or by the revolution of wheels turned by a capstan, placed within the ship;" on the contrary, no part of the Doctor's

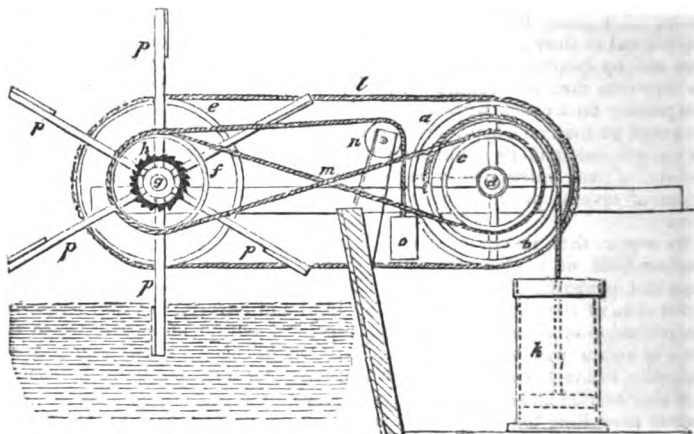
was placed outside of the vessel. His method was to form a tunnel or pipe, open at the stern of the vessel, and, by means of a pump, to force water or air through it into the sea; and by the reaction which this would occasion, the ship would be driven forward; thereby accurately "imitating what the Author of nature has shown us in the manner of swimming of fishes, who proceed in their progressive motion not by any vibration of their fins as oars, but by protrusion of their tails; and water-fowls swim forward by paddling with their feet behind their bodies." The Doctor carried his scheme into practice on a canal, with a boat of considerable dimensions, and worked his pumps by manual labour, but suggested the employment of a steam engine for that purpose, and its application to a vessel of 1500 tons burthen. This project has been subsequently repeatedly proposed, and has even formed the subject of several patents, owing to the ignorance of the parties soliciting them.

We repeat that, in our opinion, this may be regarded as the first distinct announcement of a plan by which vessels would be propelled by steam. Papin had proposed a plan, but it could not be carried into effect in the imperfect state of the engine described by him; and Savery, who also suggested the application of steam to move vessels, pointed out no method in which the power of steam was to be applied. But Dr. Allen's plan only required the application of machines already known and used for other purposes, for it could have been carried into effect by either Savery's or Newcomen's engines. The mode of propelling too is extremely ingenious; and although it may not be so efficient as that at present employed, we think that in the imperfect and rude state of mechanical knowledge at that time, it would have proved in practice as effectual as any which could be suggested. It had this advantage, that it did not require the conversion of a rectilinear motion into a rotatory one; most of the modes of effecting which, then known, were extremely inconvenient. It had also this further advantage, that the machinery was not exposed to the force of the waves or wind, and would not retard the vessel when sails alone were employed.

A few years after the publication of Dr. Allen's pamphlet, Jonathan Hulls devised a different mode for applying the power of a steam engine to navigate a vessel, and obtained a patent for the same in 1737. The letters patent, and a description of his plan, were published in a tract by Hulls, in the same year, under the following title, "A description and draught of a new invented machine for carrying vessels, or ships, out of, or into any harbour, port, or river, against wind or tide, or in a calm." His plan was to impart a rotatory movement to a paddle wheel (placed at the stern of the boat) by means of an atmospheric engine. Mr. Galloway, in his History of the Steam Engine, says that Hulls proposed to obtain a rotatory action of the wheel, from the alternating action of the engine, by means of a crank; but this is a mistake, as will be seen from the annexed sketch of his plan, which, although extremely ingenious, was certainly not so simple as the crank movement. In order to show the parts more clearly, we have drawn those wheels which are placed on the same axis of different sizes, although, in the original, they are all shown of equal size.

$a b c$  are three wheels firmly fixed on an axis  $d$ , and  $e$  and  $f$  are two loose wheels, on another axis  $g$ ; the wheels  $e$  and  $f$  have ratchets  $h$ , so that they move the axis  $g$  only when they move in a forward direction;  $k$  is an atmospheric engine, the piston of which is suspended from the wheel  $b$ ; from the wheel  $a$ , a rope  $l$  proceeds to the wheel  $e$ , and a rope  $m$  proceeds in a reverse direction from the wheel  $c$  round the wheel  $f$ , and another rope attached to the wheel  $f$ , coming over the pulley  $n$ , has a weight  $o$  attached to the end of it; this weight should be a counterpoize to about one half the effective pressure upon the piston of the engine. Upon the axis  $g$  are fixed a number of arms  $p p$ , to the extremities of which are attached paddles or float boards. The descent of the piston carries round the wheels  $a b c$  in a forward direction, and the rope  $l$  drags the wheel  $e$  round in the same direction, and with it (by means of the ratchet) the axis of the paddle wheel. In the mean time the rope  $m$  has

dragged the wheel *f* round in a reverse direction, and has raised the weight *a*. At the termination of the stroke of the piston, the weight *o* descends, and continues the rotation of the paddle wheel, and at the same time, raises the piston



to the top of the cylinder. Thus a continuous rotation of the wheels, with an equable force, is obtained from the rectilinear and intermitting action of the engine.

Both Allen's and Hulla's plans were sufficiently clear and explicit, and had they been judiciously carried into execution, even with the means then at command, must have been attended with a moderate share of success, but neither were acted upon, and for nearly half a century, the subject of steam navigation seems to have remained in abeyance. But during this interval, Watt had introduced his stupendous improvements in the steam engine, by which he not merely augmented its effectiveness, but also, infinitely enlarged the sphere of its applicability, by showing that its utility was not limited to the draining of mines, to which purpose alone it had been hitherto confined, but that it was universally applicable as a prime mover of machinery.

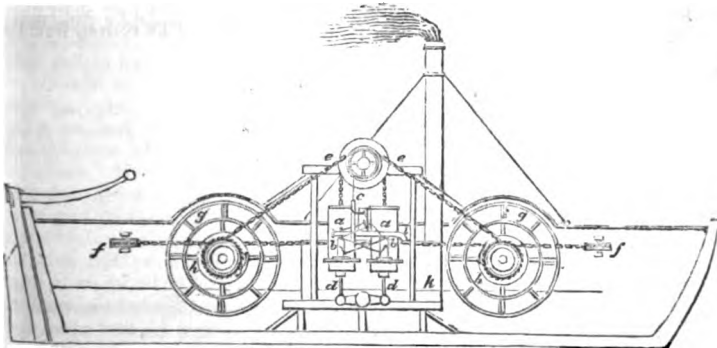
As men became acquainted with the powers of the engine in its improved form, it was gradually called into requisition for various purposes, and attempts to apply it to propel vessels seem to have been instituted at nearly the same period in various countries.

About the year 1783, Mr. John Fitch, an American, appears to have succeeded in moving a boat on the Delaware by paddles worked by a steam-engine; and he subsequently constructed another vessel of larger size; but ultimately the scheme was abandoned.

Contemporaneously with Fitch, a Mr. Rumsey of Virginia appears to have been occupied with the idea of navigating by steam. In 1787 he made some short trips upon the Potomac, in a vessel about fifty feet long, which was propelled by pumps worked by a steam engine—the plan (as we have just seen) originally proposed by Doctor Allen. The experiment being eventually given up, he came to England, where he found parties to advance the funds for another experiment; and although he unfortunately died before the whole of the arrangements were completed, the vessel was got afloat early in the year 1793, and made several trial voyages on the Thames, realising, it is said, a speed of four knots an hour against wind and tide. If this were really the fact, it seems inconceivable that the attempt should have been relinquished (as it unfortunately was), for such a performance could scarcely be deemed a failure at that period, especially if considered as a first attempt.

It has been stated, that the earliest attempts to propel vessels by steam power in this country were made by Mr. Miller, at Dalswinton, in Scotland. But

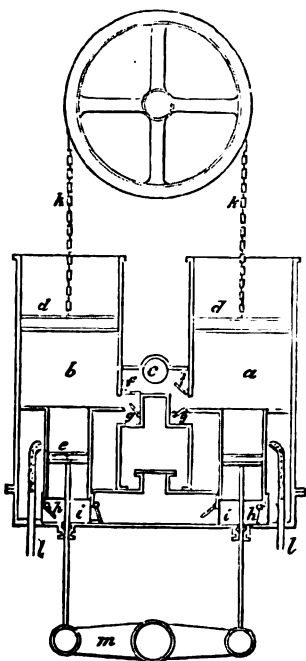
there is some ground for believing that Mr. Miller's agency was rather in the character of a patron, than that of an inventor. It seems that Mr. Miller, in 1787, published a description of a triple boat moved by wheels, with which he had been experimenting, to ascertain the comparative velocity with those moved by ordinary oars; and in this pamphlet he observed that the power of steam might be employed to give them a quicker motion. A similar suggestion has been attributed to Mr. Taylor, who was a tutor in the house at Dalswinton, and for which he has been regarded, by some writers, as the inventor of steam navigation. Under the impression that such was the fact, Lord Brougham advocated the claims of the widow of the late Mr. Taylor, and succeeded in obtaining a small pension for her, in consideration of her husband's public services. A third claimant, however, having a better title to the honour of originating this important invention, appears in the person of Mr. Symington, who was introduced to Mr. Miller in the early part of his experiments on the comparative merits of oars and paddle wheels; and by which of these three gentlemen the idea of applying steam power to move the paddles originated, is quite immaterial. But it is not questioned that Symington actually applied his steam engine to turn Miller's paddle wheels, attached to a twin boat, lying in a lake near Dalswinton-house. Symington had previously obtained a patent for his steam engine, and shown its application in a small model of a steam carriage. The transition of turning the wheels of a boat, instead of those of a carriage, was so easy and obvious, that Symington did it out of hand, and made several trials of it in 1788, which proved so satisfactory, and so delighted Mr. Miller and his numerous visitors, that he immediately determined to commence another boat on a greater scale than the first. The machinery required for this purpose was constructed at the Carron works, under the direction of Symington, and was applied to a double boat sixty feet long, which had been used for Miller's previous experiments. A trial of this vessel was made on the Forth and Clyde canal, in October 1789, and was found so efficacious, that she glided through the water at the rate of nearly six miles per hour. The mechanical arrangement of this vessel was precisely the same as the former, the only alteration being its increased dimensions, affording strong presumptive evidence of practical success, and hence rendering a description of its construction of the deepest interest in a scientific point of view; which we shall now proceed to give, with reference to the annexed sketch, which represents a longitudinal section of the vessel and its machinery.



At *aa* are the cylinders of the engines, which are a modification of the atmospheric engine as patented by Mr. Symington; *bb* are the nozzles; *c* the plug beam for working the valves; *dd* the air pump rods; *ee* connecting chains; *ff* direction pulleys; *gg* the paddle wheels, situated and wrought in a trough, extending from the stem to the stern of the boat, and allowing free ingress and egress to the water; *hh* ratchet wheels, for communicating motion to the paddle wheels. The level of the water is expressed by the horizontal line at *dd*; the boiler is at *k*.



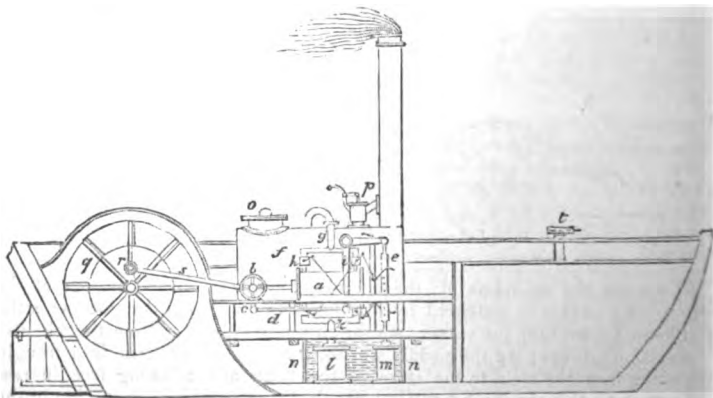




To avoid trenching upon the sweeping claims set up by Mr. Watt in the specifications of his patents, Mr. Symington was compelled to resort to several peculiar contrivances; which we shall proceed to exhibit by the annexed enlarged section of the engine only, taken from Mr. Symington, Junior's, account in the *Mechanic's Magazine*. It had two cylinders open to the atmosphere at the top, and each cylinder had two pistons, the lower ones acting as air pumps: *a* and *b* are the cylinders; *a* being in the act of receiving, and *b* of condensing the steam; *c* the steam pipe; *dd* atmospheric pistons, producing, by their alternate action on the ratchet wheels, a rotatory motion; *ee* are the exhausting pistons; *ff* steam valves; *gg* exhausting valves; *hh* foot valves; *ii* discharge valves; *ll* injecting pipes; *m* the beam.

Notwithstanding the decided success of the experiment, Mr. Miller, most unfortunately, suddenly abandoned the scheme, and Mr. Symington, not having the necessary funds himself, was unable at that time to follow it up. In 1801, however, he commenced a series of experiments on the Forth and Clyde canal, under the auspices of Lord Dundas, of Kerse, with the view of substituting the power of steam for that of horses in towing vessels on canals. These experi-

ments were highly successful, but the proprietors of the canal, apprehending that the undulation created in the water by the paddle wheels would injure the banks, would not adopt the plan, and to crown Mr. Symington's disappointment, the Duke of Bridgewater, who was in treaty with Mr. Symington for the construction of eight tug vessels for the use of his canals, died about the same time, Mr. Symington receiving the news of his death on the same day that the decision of the canal proprietors was notified to him. These accumulated disappointments appear to have been too much for his spirit, and he retired from the pursuit in despair.



The cut above represents a partial section of the *Charlotte Dundas*, one of the vessels constructed by Mr. Symington for Lord Dundas, and which in the

month of March, 1803, towed two laden boats, of 70 tons each, a distance of  $19\frac{1}{2}$  miles along the summit level of the canal, at the rate of  $3\frac{1}{4}$  miles per hour, with a strong breeze right a-head. The vessel was fitted with a cylinder of 22 inches diameter, and 4 feet stroke.

At *a* is the cylinder, placed horizontally; *b* friction rollers supporting the cross head of the piston rod; from the underside of the cross head short arms *c* project, to which are attached side rods *d*, giving motion to the bell crank lever, which works the air pump rod, as also the plug frame *e*, which regulates the valves to the boiler; *g* the steam pipe; *h h* the steam valves; *ii* eduction valves; *k* eduction pipe; *l* the condenser, which, with the air pump *m*, is placed in the cistern *n*; *o* is the man-hole; *p* the safety valve; *q* the paddle wheel, situated in a cavity in the centre of the stern of the vessel, which was open below and behind to the water; *r* the crank; *s* the connecting rod. The boat was steered by two rudders connected by iron rods, and wrought in the fore part of the vessel by the steering wheel, *t*.

About the time that Symington retired heart-broken from the field, a new adventurer appeared upon it, who was destined to achieve for steam navigation a station from which it never after receded, but on the contrary, has progressed rapidly to the present time. This was the celebrated Fulton, who, by his energy and perseverance, finally overcame the difficulties of all kinds which opposed him in the undertaking, and is generally, and in one point of view perhaps not unjustly, considered the inventor of steam navigation.

Fulton, who was born in Pennsylvania, came over in 1786 to England, where he continued to reside many years, during which time he became known to the Duke of Bridgewater, Earl Stanhope, Dr. Cartwright, and other individuals occupied with, or taking an interest in, steam navigation, with some of whom he corresponded upon the subject. In 1796 he proceeded to Paris, where he became acquainted with Mr. Livingstone, then minister from the United States to the French government. Mr. Livingstone had been engaged in some experiments in steam navigation in America, and, impressed with the importance of steam-boats to his native country, he advised Fulton to turn his mind to the subject. It was agreed between them to embark in the enterprise, and immediately to make such experiments as would enable them to determine how far, in spite of former failures, the object was attainable, and to Fulton was left the principal direction of these experiments. In the course of these experiments, which were principally made with small models, he tried many of the modes of propulsion which had been at various times proposed, as pumps, endless chains with floats, &c. He likewise appears to have returned to England for a short time, and to have visited Mr. Symington, whilst the latter was engaged in his experiments on the Forth and Clyde canal; and it is stated that Mr. Symington, to oblige him, got up the steam on board the vessel, (the *Charlotte Dundas*,) and proceeded, with Mr. Fulton on board, about 4 miles and back, and that he furnished, or allowed Mr. Fulton to take, notes and sketches of the boat and apparatus. Mr. Fulton finally decided in favour of paddle wheels, and proceeded to construct an experimental vessel on the Seine. The length of the vessel was 66 feet, and her width 8 feet, and in the autumn of 1803 he made a trial of her, from which he acquired such confidence, that orders were transmitted to Boulton and Watt to prepare a steam engine to be sent to New York, and Fulton returned to England to watch its progress. In 1806 he returned to America to construct the vessel, and in the spring of the year 1807, she was launched; and the engine was fixed in her by Boulton and Watt's men. This vessel, whose renown will outlive that of the *Argo*, was named the *Clermont*; she was 133 feet long, 7 feet deep, 18 feet wide, and 160 tons burthen. The steam cylinder was 2 feet diameter, with a 4 feet stroke; the paddle wheels were 15 feet in diameter, the floats were 4 feet wide, and dipped in the water 2 feet.

Early in the autumn the vessel started on her first trip, which was to Albany, distant about 150 miles; which distance she accomplished in 32 hours. The voyage back was performed in about the same time, and both in going and returning, the wind (a light breeze) being ahead, the whole was performed by the engine.

This triumphant experiment established Fulton's reputation; and soon after, this fine vessel plied between New York and Albany as a passage boat. Her success was such, that a new vessel of larger dimensions, and of greater proportionate power, was commenced during the same year. From that date steam navigation was firmly established in America, and went on extending with astonishing rapidity. Fulton in consequence realized large sums, but his prosperity was not without alloy, and he was doomed to experience the lot of most mechanical inventors, who are too frequently exposed to mortification, as well by the success as by the failure of their schemes. No sooner had he established the practicability of his plans, than attempts were commenced to infringe upon or evade his patent; and he was from that time continually engaged in a series of lawsuits, to protect his hard-earned privileges. In consequence of the expense attending these proceedings, and that of the experiments he was constantly engaged in, although he lived without ostentation or extravagance, his affairs after his death (which happened in February, 1815) were found to be excessively involved; and it is to be feared that his family reaped but little benefit from his meritorious labours, which have been productive of such signal benefit, not only to his own country, but to the world at large.

Although we have said that in one sense Fulton may be considered the *inventor* of steam navigation, we feel that this is not exactly the position which he occupies in relation to this invention, and we use the term for want of one as compendious, and at the same time more accurate. Strictly speaking, Fulton cannot be said to have contributed anything to the invention. As regards the mere idea of moving vessels by steam, Dr. Allen and Hulls had each invented and published practicable plans, by which it might be effected, more than 70 years prior; neither was he the first to attempt to realize those schemes, either here or in his own country; and if it be said that he was the first who attained complete success, we reply that both Symington and Rumsay had fully triumphed over the mechanical difficulties of the task, and the invention was completed before he took it in hand. And yet, notwithstanding that this is (we think) undeniably true, it is in our opinion equally true that to him we owe the gift of steam navigation, with the various blessings which it has bestowed. Although the invention had been completed by others, it might be considered as lost to society, which did not appreciate its value, until Fulton by his untiring energy and perseverance, practically demonstrated its transcendent importance, and forced conviction upon his ignorant and incredulous contemporaries. In corroboration of this view of the subject, we would add, that notwithstanding Symington's successful labours, it was not until nearly ten years after their termination that the first steam boat was established in Great Britain, and then principally in consequence of the notices which from time to time appeared of the progress of steam navigation in America.

On the next page are given engravings of the arrangements of a Scotch steam boat, which is common on the river Clyde. *Fig. 1* represents a longitudinal and vertical section, from stem to stern; and *Fig. 2* a plan of the same, showing the deck removed. Similar letters in each figure refer to corresponding parts. At *a a* are the boilers; *b* the chimney, leading from the flues of both the fires; *c* is the steam pipe, which receives the steam from both the boilers, and conveys it by a cross tube to the two cylinders *d d*, through the valve boxes at *f f*. The air pumps *e e* are worked by the main-beam, and the eccentric, for giving motion to the valves, is shown at *g*. *h h* paddle wheels; *i* one of the paddle boxes in section. At *j* is the fore cabin, *k* the after cabin, *o o* the staircases, *l l l* the framing of timber, which supports a platform or deck, (commonly called the gangway,) which nearly surrounds the hull of the vessel.

No attempts were made, we believe, to perform sea voyages by steam boats, until the year 1818; when they were established by Mr. David Napier. Shortly afterwards, the Irish mails were conveyed between Dublin and Holyhead by regular steam packets.

At length the longest voyages were attempted by steam. In the year 1825, the *Enterprise*, a vessel of 470 tons burthen, and 120 horses power, sailed for

Fig. 1.

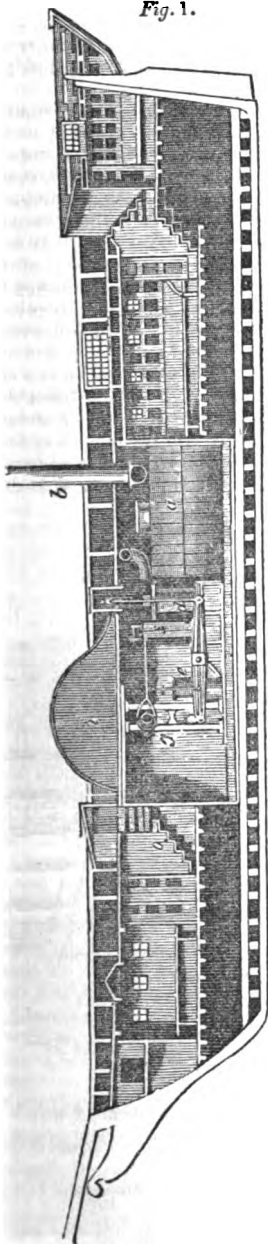
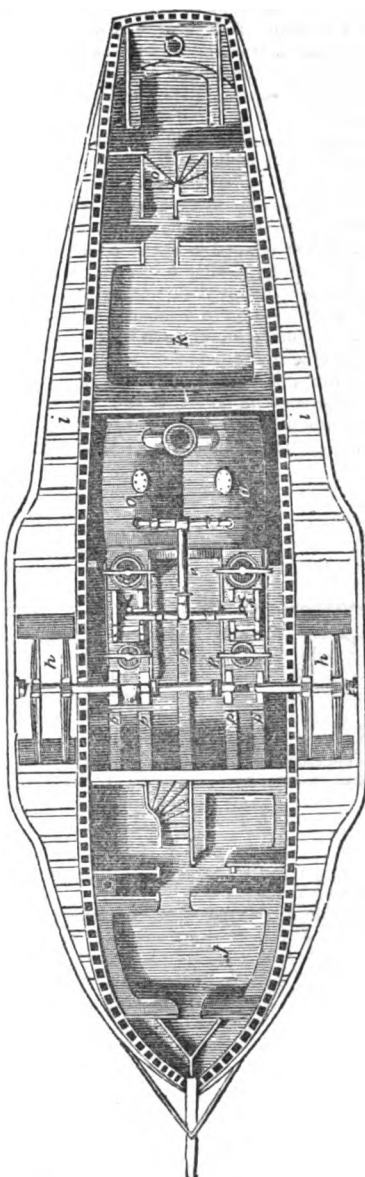
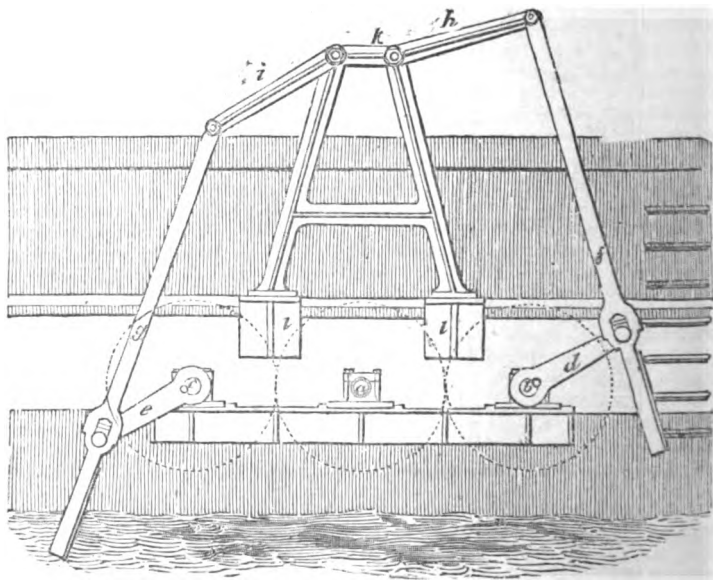


Fig. 2.



India. She left the land on the 16th of August, and reached Calcutta, Dec. 7, 1825; being 113 days from the land to Diamond Harbour. She used both sails and steam. The greatest run by sail in 24 hours was 211 miles; the least 39 miles. The greatest run by steam, assisted by sail, was 225 miles; the least 80 miles. She steamed 64 days, and the rest of the time was under sail. The consumption of coal was 580 chaldrons, or about 9 chaldrons per day. She rendered essential services to our arms during the Burmese war.

A recent application of the power of steam, which is calculated to be of signal benefit to the commercial marine of this country, is the employment of it on a limited scale as an auxiliary to shipping during calms and light airs. One of the first vessels in which steam was so applied was the *Maria*, of 460 tons register, which sailed to Bombay. She was fitted with a propelling apparatus, the invention of Mr. J. Melville, and designed principally for the purpose of propelling sailing vessels in calms, to which purpose, it appears to us to be extremely well adapted. The annexed figure shows an elevation of the apparatus as applied to the *Maria*. *a* is the engine shaft, situated between the two propelling shafts, *b* and *c*. These three shafts are caused to revolve together with equal velocities, by means of three spur wheels, of equal diameter, fixed one upon each shaft within the vessel; and therefore shown by dotted lines. Upon the outer ends of the shafts *b* and *c* are fixed the cranks *d* and *e*, in diametrically opposite directions, so that they remain constantly parallel to each other; but whilst one crank is ascending, the other is descending; *f* and *g* are the propelling levers, or stems, to the lower ends of which the floats *m* and *n* are attached. These levers turn upon the pin of the propelling cranks *d* and *e*, and are guided in their motions by the radius rods *h* and *i*, connected to their



upper ends. The radius rods are connected to a cast iron frame, *k*, which is supported on two brackets, *l*, attached to the side of the vessel. The principal dimensions of the apparatus are as follows:—

	Feet	In.
Diameter of cylinder . . . . .	0	10 $\frac{3}{4}$
Length of stroke . . . . .	2	0
Diameter of the spur wheels at the pitch lines . . . . .	4	10

	Feet	In.
Diameter of the paddle cranks . . . . .	3	0
Breadth of paddles . . . . .	2	0
Depth of ditto . . . . .	2	0

Subsequently to the instance of the *Maria*, numerous vessels have been fitted with auxiliary steam power; and "auxiliary steamers" are now employed on several trading lines. These being built expressly for the purpose, have, in most cases, screw propellers. Amongst the largest of these vessels is the *Antelope*, of 600 tons, and the *Emerald*, of 700 tons, and 50 horse power, trading between London and Belfast; and the *Sarah Sands*, of 1000 tons, trading between Liverpool and Rio Janeiro.

The government likewise appear to appreciate the advantages which may accrue to the navy from the application of steam as an auxiliary. In addition to several guardships at the different ports so equipped, the *Amphion*, 36 gun frigate, of about 1500 tons burthen, has been fitted with a screw propeller, driven by engines of 300 horse power. By means of this steam power, she can, it is stated, command a speed, under ordinary circumstances, of nearly 7 knots per hour under steam alone; and with steam and sail combined, a speed which in all cases shall render her superior to every other mere sailing ship she may meet with. Another "auxiliary" frigate, the *Arrogant*, of 1850 tons and 360 horse power, with a screw propeller, is building.

The following Table contains some of the dimensions of the hull and machinery of some of the largest steam vessels yet built.

DIMENSIONS.	Great Western.	Terrible, Steam Frigate.	British Queen.	President.	Great Britain.	
Extreme length . . . . .	236	—	275	265	322	feet.
Ditto, under Deck . . . . .	212	—	245	238	—	"
Ditto, Keel . . . . .	205	226.2	225	220	289	"
Breadth within the Paddle Boxes	35.4	42.6	40	41	51	"
Ditto, including ditto . . . . .	59.8	—	64	64	—	"
Depth of Hold at Midships . . . . .	23.2	27.4	27.6	23.6	36	"
Tons of Space . . . . .	679½	—	1053	—	1000	tons.
Tonnage of Engine Room . . . . .	641½	—	963	—	—	"
Total Tonnage . . . . .	1321	1850	2016	1840	3443	"
Power of Engines . . . . .	450	—	500	540	—	horses.
Diameter of Cylinders . . . . .	73	—	77½	80	4 of 88	inches.
Length of Stroke . . . . .	7	—	7	7½	6	feet.
Diameter of Paddle Wheels . . . . .	28.9	—	30.6	31	—	"
Total weight of Engines, Boilers and Water . . . . .	480	—	500	500	740	tons.
Total weight of Coals, 20 days' consumption . . . . .	600	—	750	750	1000	"
Total weight of Cargo . . . . .	250	—	750	750	—	"
Draught of water with the above weight of Stores . . . . .	16.8	18.9	16.7	17	16	feet.



## SECTION II.

## THE CONSTRUCTION AND ARRANGEMENT OF STEAM VESSELS.

Differences between Steam and Sailing Vessels.—Form and Proportions.—Resistance.—Beaufy's Experiments.—Rusell's Experiments.—Remarkable deviations from the assumed law of velocity.—"The solitary wave of progression" not dependent upon form or velocity, but upon the depth of the fluid.—Mr. Houston's accidental discovery of a diminution of resistance at certain increased velocities of motion.—Form of vessel of least resistance.—The "Wave"-lines of.—Sir J. Robison's Experiments.—Mr. Oldham's suggestion for improved experimental apparatus.—Tables showing results of experiments.—Proportion of power to tonnage or admeasurement.—Velocity of the great American steam raft.—Approximate Tables of tonnage, power, and consumption of fuel.—Mr. Morgan's assignment of due proportion of power to tonnage.—Dimensions of several Government steam packets.—Specification for constructing a 600 ton steam packet.—Diagrams of.—Separate water-tight iron bulkheads.—Mr. Lang's method of Diagonal Planking.—Iron vessels—advantages of.—Dimensions of the iron steam boat "Alburkah."—Construction and dimensions of the hull and machinery of the great iron steam ship, "Great Britain."—Twin boats.—The great American steam raft.—Snodgrass's twin boats.—Gemmel's twin boats.

In proceeding to describe the form and construction of steam boats, we shall commence by noticing the points in which they most differ from sailing vessels. As the wind is generally more or less oblique to a vessel's course, or directed against the side of the vessel, and as the centre of effort of the sails in a ship is at a considerable height above the longitudinal axis of rotation, the wind acts with considerable leverage upon the sails and masts, to cause the ship to heel, or incline over to one side: to counteract this, and impart sufficient lateral stability, or stiffness, the breadth of sailing vessels requires to bear a greater proportion to the length than is necessary in steam vessels: the whole of the impelling force in the latter being exerted in the line of the vessel's course. Sailing vessels likewise require to be of greater comparative depth than steamers, to prevent their being driven laterally out of their course, (or to leeward, as it is termed,) when the wind is contrary; steamers being capable of proceeding directly head to wind, the point to be chiefly attended to is, that the form of the hull be such as to oppose the least resistance to its direct progress; and as the resistance depends chiefly upon the area of the immersed transverse section, their breadth and depth are generally considerably less than that of sailing vessels of the same tonnage, and the requisite capacity is obtained by a proportionate increase of length; thus, whilst in sailing vessels the breadth is rarely less than one-fourth of the length, in steam vessels it is frequently only one-seventh. Other advantages likewise result from this change in the proportions: steam vessels being employed chiefly as coasters, their light draught of water enables them to enter harbours which would otherwise be inaccessible to them. Their increased length also assists in preserving their parallelism, upon which their velocity greatly depends; and, as they do not pitch so suddenly nor so deeply in heavy seas, they hold their way better, and the hull and machinery are less strained. Their increased length likewise affords greater accommodation for passengers, which is a very great advantage.

*Resistance of Floating Bodies.*—The question as to the best form for vessels, is one which has long excited much attention in this and foreign countries. Many attempts have been made to determine, both by mathematical deduction and by experiments, the amount of the resistance of water to bodies of different forms, and the form of least resistance. But, since the application of steam to the purpose of navigation, the question becomes still more interesting; as, from the great expense of steam compared with wind, as a propelling power

for vessels, and the space occupied by the machinery, which tends greatly to limit the room that can be allotted for fuel, and, consequently, the time which steamers can keep at sea, it becomes of the utmost importance to economise the power, by reducing the resistance as far as possible. The question also admits of nearer approaches to accuracy in the solution in the case of steamers than in that of sailing vessels, as experiments may be conducted so as to assimilate more to practice in the former case, than in the latter. The propulsive action of steam is likewise more direct than that of wind, and its force more constant and easily computed than that of the wind, which is constantly varying, and cannot be accurately estimated.

*Beaufoy's Experiments.*—The most extensive sets of experiments upon the resistance of fluids to floating bodies, are those instituted in Sweden, under the sanction, and at the expense, of the Society of Iron Masters of Stockholm, and the experiments which were commenced in this country by the Society for the Improvement of Naval Architecture, but which were subsequently carried on solely by the late Colonel Beaufoy, who devoted upwards of twelve years to the experiments, and to the calculations founded thereon, and expended several thousands of pounds in the prosecution of his researches. The results of his labours have, since his death, been given to the world by his son, H. Beaufoy, Esq., of Lambeth; who published the experiments in a thick extra quarto volume, and, with a zeal in the cause of science, and a generosity, congenial with his father's, has printed 1,500 copies "*for the honour of gratuitous distribution.*"

This work contains most laborious investigations of the resistance of water to bodies of great diversity of forms, and at greatly varying velocities; unfortunately, however, the conditions exclude circumstances which materially influence the result in all practical cases, and the conclusions, therefore, must be considered rather as abstract truths, than as pointing out the results to be expected in practice, unless modified by allowances for the actual circumstances of each case.

*Mr. Russell's Experiments.*—In order to render the deductions of theory more consonant with the results obtained in practice, J. S. Russell, Esq., of Edinburgh, conducted a series of experiments in the years 1834 and 1835, upon the Forth and Clyde canal, under circumstances more analogous to the cases of actual practice than those of previous experimenters. He has since given an account of these experiments in Vol. XIV. of the Transactions of the Royal Society of Edinburgh, of which we shall avail ourselves for a few extracts. The account is highly interesting, and likely to prove of great practical utility; Mr. Russell having ascertained the existence of certain phenomena not before adverted to, as well as the laws which regulate them; which throw great light on many intricate and perplexing points, and go far to account for the discrepancies which most accounts of extensive series of experiments exhibit.

Mr. Russell observes, that the law which connects the resistance of the fluid with the second power of the velocity, agrees very nearly with the motion of bodies that are wholly immersed, and with the motion of floating bodies that have certain velocities, and are placed in certain circumstances; but it is widely erroneous in its direct application to the motion of floating bodies at higher velocities and under different circumstances. In every large collection of experiments, examples are to be met, where the resistance, instead of following the law of the squares of the velocities directly, has been found to vary, not only with every different power of the velocities, from the first to the fourth power, but also in the inverse ratio of some of these powers. Two very striking illustrations of this are given in the following experiments by Mr. Russell; the one showing an increase of resistance, corresponding with a very high power of the velocity, and the other exhibiting a decrease of resistance, with an increase of velocity greater than the former. They were made October 18, 1834, with a floating body weighing 12,579 lbs. :—



## EXAMPLE I.

	Space described.	Time.	Velocity in feet per Second.	Resistance in lbs.
Experiment 1.	1,000 ft.	117.5	8.51	233
„ 2.	1,000 „	93.5	10.69	425

## EXAMPLE II.

Experiment 3.	2,640 ft.	302.	8.76	261
„ 4.	500 „	35.	14.28	251

In the first two experiments it will be seen that the resistance increases in a greater ratio than the squares of the velocities, by nearly 15 per cent; whilst in the last two, in which the velocity increases from 8.76 to 14.28, the resistance actually becomes less, amounting to scarcely  $\frac{1}{3}$  of what the law of the squares of the velocities would indicate.

The result of Mr. Russell's investigations appears to establish the following conclusions:—

That the resistance does not follow the ratio of the squares of the velocities: except in those cases where the velocity is low, and the depth of the fluid considerable. That the increments are greater than those due to the squares of the velocities, as the velocity approaches a certain quantity, which is determined by the depth of the fluid. That at this point the resistance attains a first maximum; and that here, by certain elements of the form of the body, and of the dimensions of the fluid, they may become infinite. That immediately after this, there occurs a point of minimum, where the resistance becomes much less than that due to the square of the velocity; after which it continues to receive increments of which the ratio is less than that due to the square of the velocity. That according to the law of progression which has been established, the resistance will reach a second point of maximum when a velocity shall be obtained of 29 miles per hour, after which it will be rapidly diminished with every increase of velocity.

These singular deviations of the law of resistance from a uniformly progressive ratio arise principally from two causes, but slightly (if at all) adverted to by former experimenters. The first of these is an *emersion* of the floating body from the fluid, due to the velocity of the motion of the body, and by which the dynamic immersion is rendered less than the statical immersion of the body in the fluid. The second is the generation of waves by the floating body in the direction of its motion, which affect the form and surface of the fluid, the position of the floating body, and of the resistance. The velocity of these waves (which Mr. Russell calls *the wave*, or the *solitary wave of progression*) depends neither upon the form of the floating body, nor the velocity of its motion, but solely upon the depth of the fluid.

The first of these phenomena had been slightly noticed by some previous observers, but the fact was questioned by many writers. Mr. Russell, however, has established the fact experimentally, and has laid down the theory by which it is to be accounted for. To ascertain the fact of emersion, the following experiments were made. A slight skiff was fitted with 12 glass tubes, accurately graduated, which passed through holes in the bottom of the vessel, and were open at both ends, so as to allow the water to rise within the tubes to the level of the water outside the boat. The boat thus fitted was drawn along the canal at different velocities, and the height at which the water stood in the tubes was carefully noted by an observer seated in the boat. The immersion of the boat when at rest being 2.7 inches, the dynamic immersions were as under:—

## MILES PER HOUR.

Velocities.	0	3	4	5.16	6.43	7.25
Dynamic Immersions.	2.7	2.6	2.5	2.2	1.9	1.8

Having thus clearly established the fact by experiment, Mr. Russell gives the following proposition in explanation of it, viz., that the pressure downwards upon a fluid, by a body in motion at a given velocity, is diminished by a quantity equal to the pressure of a column of the fluid, having the height due to the velocity of the motion. The form of the floating body is no element in the formula of emersion, the law being a general one, and having for its foundation this simple principle, that gravity acting on a solid body during a given unit of time is a constant quantity, and that the displacement of the fluid by the weight of the body, being a quantity that increases both with the velocity and with the quantity of that displacement, must ultimately be equal in quantity, as it is opposite in direction, to the pressure of the solid downwards by gravity. When, however, the depth of the fluid is small, the results will be modified by the wave, and other elements of resistance.

With regard to the second and chief cause by which the resistance is influenced—the *wave*—Mr. Russell concludes, from his investigations, that the restoration of the equilibrium amongst the particles of the fluid which has been disturbed by the motion of a floating body, is effected not so much by the generation of currents in the fluid, as has been hitherto generally assumed, as by the generation of waves, which form elevations in front of the moving body. These waves travel to a great distance, with a velocity which is nearly uniform, and which depends solely upon the depth of the fluid; and in channels of rectangular section does not differ sensibly from that which is acquired by a heavy body falling freely by gravity, through a space equal to half the depth of the fluid. In a channel 5.5 feet deep, the velocity of the wave is about 8 miles per hour.

The resistance will chiefly depend upon the relative velocities of the wave and of the vessel; the resistance increases rapidly as the velocity of the vessel approaches that of the wave.

When the vessel moves slower than the wave, the elements of increased resistance are:—

- 1.—Increased immersion of the bow in the anterior wave.
- 2.—Inclination of the longitudinal axis of the floating body, so as to change the form of the displacing body.
- 3.—Increased vertical section opposed to resistance—the sine of the inclination
- 4.—Increased velocity of the lateral current.

The following table shows the rapid increase of resistance in approaching the velocity of the wave. It is extracted from the experiments of 1838.

EXPERIMENT I.

EXPERIMENT II.

Miles per Hour.	Resis. lbs.	Miles per Hour.	Resis. lbs.
5.05	52.25	5.05	95
5.45	78.5	6.19	152
6.49	111.	6.49	312
7.57	255.	6.81	386
7.568	330.	7.	392
Velocity of Wave, 8 Miles.		Velocity of Wave, 8 Miles.	

Let it now be supposed that the vessel had created a wave by its motion, and suppose it possible to lift the vessel entirely out of the water, and place its centre on the top of the wave, the stem being anterior to the wave, and its stern behind it, and suppose the vessel to be of such form as to remain in a state of equilibrium on the surface of the fluid having the form of the wave, and that the velocity of the vessel be such as to keep it in the same relative position to the wave, the following results would be obtained:—

- 1.—The vessel would recover its horizontal position, and would present the minimum transverse section of resistance.

2.—The immersion of the vessel being increased by the height of the crest of the wave around its centre of gravity, the head and stern displacements would be diminished (the total immersion being a constant quantity) by the amount of excess of central displacement.

3.—The velocity of the vessel being now increased beyond that of the wave, the waves of displaced fluid continually falling behind the points where they were raised, would form a series of great central waves, bearing the vessel on their summit.

When the velocity is greater than the wave, it might be expected that the wave would be left behind; but, in this case, it should be observed that a new wave is formed at every instant by the motion of the vessel through the water, whatever be its velocity; for the displaced fluid thrown aside at the bow generates a series of waves, which move with a less velocity than the vessel, and fall back behind the bow.

It is always found that the commotion produced in the fluid at velocities less than the wave is greater than at velocities exceeding that of the wave. The stem of the vessel in the latter case enters water which is perfectly smooth and undisturbed, because no wave has previously passed before the vessel to produce any anterior derangement.

It is to the diminished anterior section of displacement produced by raising a vessel with a sudden impulse to the summit of the progressive wave, that a very great improvement recently introduced into canal transport owes its existence. The isolated fact was discovered accidentally on the Glasgow and Ardrossan canal, which is a canal of small dimensions. A spirited horse, in the boat of Mr. William Houston, took fright, and ran off, dragging the boat with it, and it was then observed, to Mr. Houston's astonishment, that the foaming stern surge, which used to devastate the banks, had ceased; and the vessel was carried on through water comparatively smooth, with a diminished resistance. Mr. Houston, perceiving the mercantile value of this fact, devoted himself to introducing on that canal vessels moving with this high velocity. The result of this improvement has been to bring from the conveyance of passengers at a high velocity a large increase of revenue to the canal proprietors. The passengers and luggage are conveyed in light boats about 60 feet long, and six feet wide, made of thin sheet iron, and drawn by a pair of horses. The boat starts at a slow velocity behind the wave, and at a given signal, it is, by a sudden jerk of the horses, drawn up on the top of a wave, where it moves with diminished resistance, at the rate of 7, 8, or 9 miles per hour.

It appears, from the experiments of 1835, that a vessel has conveyed on a canal given weights with the following forces:—

Moving Force.	Weight Moved.	Velocity.
71.5 lbs.	19.222 lbs.	4 Miles per Hour.
86. „	19.222 „	4.5 „
112. „	19.222 „	5.2 „
246. „	8022 „	11.3 „
264. „	9262 „	13.6 „
331. „	10.262 „	15.1 „

In these experiments the vessel which experienced the least resistance was one designed by Mr. Russell, and to which he gave the name of *The Wave*.

This vessel was of very peculiar form, which suggested itself to Mr. Russell as a form of least resistance, and which even surpassed the expectations he had formed of the facility of her motion. The lines of entrance are parabolic tangent arcs, having a point of contrary flexure between the maximum transverse section and the stem. The run is formed of elliptical arches, and is by no means so fine as runs usually are. Mr. Russell was led to devise this form, from an opinion, confirmed by long observations, that the maximum resistance

to a vessel of ordinary form is experienced in the immediate vicinity of the stem; that the water there is thrown aside with a velocity much greater than is requisite to remove the particles from the space to be passed over by the succeeding points of the bow. This head of water at the bow, instead of being merely thrown aside, is also thrown upwards and forwards, so as very much to increase the resistance beyond what appears necessary for the transit of the vessel. It occurred to him, that a form might, perhaps, be obtained which would not, at any given velocity, raise a head of water above the level, but merely give to the particles displaced the minimum of lateral motion required to permit the transit of the vessel. From his investigations he obtained a curve which appeared to him to be a curve of least resistance, and the vessel named *The Wave* was built conformably thereto; and the truth of his theory, being tested by experiment, was fully confirmed. This vessel, when deeply laden, and moving with a velocity of seventeen miles an hour, causes no spray, foam, surge, nor head-water at the bow, but the water is parted smoothly and evenly asunder, and quietly unites after the passage of the vessel; adhesion, alone, to the vessel drags forward a film of adjacent fluid; all else remains quiet and smooth.

The form of *The Wave* has been followed, as nearly as circumstances would admit, in some steamers recently constructed, and the results have been highly satisfactory.

*Sir J. Robison's Experiments.*—Prior to the experiments of Mr. Russell, J. Robison, Esq., afterwards Sir J. Robison, had instituted a series of experiments on the Forth and Clyde canal, with the view of ascertaining the best form of canal boats. Of these experiments (to which those of Mr. Russell may be considered as a sequel, as they were, we believe, undertaken at the suggestion, and made chiefly at the expense, of Mr. Robison) he has furnished an interesting account, in a communication to the Society of Arts, which appeared in the Transactions of the Society for 1833, from which we make the following extract:—

“Four models were prepared of the following dimensions—

	Ft. In.		Ft.			Ft. In.	
No. 1 was	8	3	Long,	2	Wide, and	1	0
” 2 ”	8	3	”	2	”	1	6
” 3 ”	8	3	”	2	”	1	6
” 4 ”	9	1	each part	1	foot wide	1	0
							”

And the weight of each 187½ lbs.

“No. 1 was quite flat on the floor, rounded at the bilges, and perpendicular in the sides at the midships section, but with a fine entrance and run.

“No. 2 was made in the proportions of an ordinary coasting trader.

“No. 3 in the proportions of a sharp built schooner.

“No. 4 was a twin-boat, similar in its dimensions to No. 1, only that the breadth of each portion was half of the other breadth: the depth was the same.

“The weight of all the models being alike, their displacement of water was equal, although their draft or depth of immersion was necessarily different.

“The usual way of trying the resistance of floating bodies is by drawing them across a dock or basin by a cord, running over delicately hung pulleys, on a high mast, and with certain weights attached; the time is accurately noted which each form requires to move through a certain space, and the comparative resistances are calculated from these elements. This method presents many difficulties and disadvantages. I was enabled, however, by a suggestion from an ingenious friend (Mr. Oldham, of the Bank of Ireland), to adopt a much more summary and satisfactory way of determining the comparative resistance of the different models; and, as it was the comparative resistance alone which required investigation, I had no occasion to go through the more tedious process of trying the resistance only, and of incurring the risk of error

from mistake in reading off the indications of the dynamometer. I prepared, accordingly, a spar, or yoke, sixteen feet eight inches long, which was divided into 100 parts of two inches each: a small eye-bolt was fixed at each extremity, and a shifting hasp was fitted to the middle part. With this yoke all the experiments were made, by the two following processes:—First, a model was attached, by a slender tow-line, to each eye-bolt, and the hasp was fixed exactly in the middle of the yoke, and linked to an outrigger on the steam vessel, which was then set in motion at the required speed. If it was found that one of the models preceded the other in consequence of its offering less resistance, the hasp was shifted along the spar towards the sluggish one, until the resistances were balanced, and the two models ran abreast of one another. The relative lengths of the arms of the yoke then gave an inverse measure of the comparative resistances of the models at that rate of speed; this being noted down, the hasp was brought again to the middle of the yoke, and the model which showed least resistance was, by degrees, loaded with weights, until it again exactly balanced the other, and swam abreast of it; the amount of the added weights being likewise noted, afforded a second measure of the difference of the resistance of the two models.

“ Each of these forms of the experiment was gone through with different pairs of the models, and was frequently repeated through long spaces of the canal, as it was found that various circumstances interfered to render the resistances inconstant, such as approaching nearer to the one or other side of the canal, passing a loaded vessel, or making a turn round a projecting part of the bank. It was first attempted to conduct the experiments by towing the models astern; but it was immediately found that the ripple of the wake of the steamer disturbed the uniformity of the resistance of the models. Various modifications were then tried, with more satisfactory results, and finally the arrangement was made as follows:—A spar like a bowsprit, about twenty feet in length, was run out a little above the level of the water from the bow of the steamer, the hasp of the yoke being attached by a link to the point of the spar, the models were in this way kept ahead of the steamer in smooth water, and were altogether undisturbed by any ripple or wave.”

The accompanying tables contain the results of these trials, from which the important inference may be drawn, that there is no form which will present a minimum resistance in all circumstances; and that the form which is easiest drawn through the canal at a low velocity, does not possess the same advantages at a higher rate of speed.

By looking into the table A, experiment 1st, we see that, although the resistance of No. 1 be to that of No. 2 as 13 to 12 when the velocity is three miles per hour, yet, when the speed is increased to six miles, the advantage which No. 2 had over the flatter vessel entirely disappears.

Again, in Table B, we see that in one experiment No. 2 carries two-ninths more weight than No. 1 with equal resistance when the velocity is three miles per hour; but that, when the rate is raised to six miles, the loads required to be the same in both, in order to equalize the resistance.

It appears, from numerous experiments made at intermediate speeds, that this change in the relative resistance is progressive: there is reason, therefore, to conclude, that if circumstances had admitted of carrying on the experiments at a higher velocity than six miles per hour, the flatter formed vessel would have attained a superiority over the sharper ones. This conclusion is corroborated by the fact that the swiftest going steam vessels which have been built in this country, are those which are nearly quite flat in the floor for a great proportion of their whole length.

The first practical inference which may be drawn from these experiments is, that all vessels which are intended to be tracked, or impelled by machinery through canals, at low velocities, should be built as sharp in their bottoms as circumstances will admit of, although this must necessarily increase their draught of water; the second inference is, that whenever vessels are intended to move in canals with a higher rate of speed than six miles per hour, the general form of the bottom should be quite flat.

TABLE A.  
EXPERIMENTS WITH EQUAL LOADS.  
(*In favour of No. 1.*)

Models tried.	United Weights of Vessel and Load.	Divisions in the Arms of Yoke when at 3 Miles per Hour.	Difference.	Divisions in the Arms of Yoke when at 6 miles per hour.	Difference.
Flat Vessel & Coaster. } No. 1 and 2 ditto ditto ditto	192 lbs. each.	No. 1, 48	4 Divisions = $\frac{1}{4}$	No. 1, 50	None.
	256 "	" 46	" = $\frac{1}{4}$	" 50	None.
	320 "	" 47	" = $\frac{1}{4}$	" 49 $\frac{1}{2}$	1 Division = $\frac{2}{3}$
	392 "	" 45	" = $\frac{1}{4}$	" 49	2 " = $\frac{1}{4}$
Flat Vessel & Schooner. } No. 1 and 3 ditto ditto ditto	192 "	No. 1, 45	" = $\frac{1}{4}$	No. 1, 50	None.
	256 "	" 43	" = $\frac{1}{4}$	" 50	None.
	320 "	" 44	" = $\frac{1}{4}$	Uncertain.	
	392 "	" 45	" = $\frac{1}{4}$	No. 1, 49	2 Divisions = $\frac{1}{4}$
Flat Vessel & Twin ditto. } No. 1 and 4 ditto ditto ditto	256 "	No. 1, 50	None.	Uncertain.	
	320 "	" 53	6 Divisions = $\frac{1}{4}$	ditto	
	392 "	" 52	4 " = $\frac{1}{4}$	ditto	

TABLE B.

*Experiments with equal arms of the Yoke at 3 miles per hour.*

Models Compared.	Depth of Immersion in Inches.	Weight of Vessels with their Loads.	Difference.	
Flat Vessel. No. 1	4.91	256 lbs.	} 32 lbs.	No. 2 carries $\frac{1}{4}$ more than No. 1.
Coaster. No. 2	8.5	288 "		
	No. 1	6.083	} 72 lbs.	No. 2 carries $\frac{2}{3}$ more than No. 1.
	No. 2	10.083		
Flat Vessel. No. 1	4.17	192 "	} 42 lbs.	No. 3 carries $\frac{2}{3}$ more than No. 1.
Schooner. No. 3	8.41	234 "		
	No. 1	5.75	} 42 lbs.	No. 3 carries $\frac{2}{15}$ more than No. 1.
	No. 3	10.25		
Flat Vessel. No. 1	4.17	256 "	} 0	No difference at this rate of speed.
Twin Vessel. No. 4	4.	256 "		

N.B. The depth of immersion entered above is that observed when the vessels were at rest, and which did not appear to alter when in motion.

TABLE C.

*Experiments with equal arms of the Yoke at 6 miles per hour.*

Models Compared.	Depth of Immersion in Inches.	Weight of Vessels with their Loads.	Difference.	
Flat Vessel. No. 1	4 $\frac{2}{15}$	192 lbs.	}	The draught of water noted in the column of immersions was that observed when the models were at rest previous to the commencement of each experiment; the actual immersion during the experiment was considerably less, especially in the flatter vessels; but there were no means of ascertaining it precisely.
Coaster. No. 2	6 $\frac{4}{15}$	192 "		
	No. 1	4 $\frac{11}{15}$	} 256 "	
	No. 2	8 $\frac{1}{15}$		
Flat Vessel. No. 1	4 $\frac{2}{15}$	192 "	}	
Schooner. No. 3	7 $\frac{2}{15}$	192 "		
	No. 1	4 $\frac{11}{15}$	} 256 "	
	No. 3	9 $\frac{2}{15}$		
Flat Vessel. No. 1	5 $\frac{2}{15}$	320 "	}	
Twin Boat. No. 4	5 $\frac{7}{15}$	320 "		

*Proportion of Power to Size of Vessels.*—The proportion which the power of the engines should bear to the size of the vessel depends greatly upon the nature of the service for which the vessels are intended. Post-office packets, and vessels depending chiefly upon passengers, for instance, require and will admit of engines of larger power than vessels employed principally in the transport of goods; in which latter, less space can be afforded for the machinery and fuel, on account of the room required for the cargo. The proportional power must likewise depend partly upon the size of the vessel, for, as the resistance to a vessel's progress depends principally upon the area of the transverse section immersed, which area does not increase in the same proportion as the capacity of the vessel, larger vessels require less power in proportion than smaller ones. For instance, if two vessels be built upon the same model, but one of them of double the tonnage of the other, their proportional linear dimensions will be as 126 to 100, and their sectional areas as 158 to 100; therefore, to obtain the same velocity, the power will only require to be increased in the same ratio as the sectional area, or as 158 to 100; if the power in each vessel were in the direct ratio of the tonnage, or as 200 to 100, the ratio of the power to their sectional areas would be 200 to 158.

Viewed solely as a question of economy without regard to speed, it might at first sight be concluded that vessels must be worked at less cost with engines of small power than with large ones, for the resistance to a vessel's motion through the water increases more rapidly than in the ratio of the velocities. The resistance of a fluid to a body moving therein is generally stated to be as the square of the velocities; a double speed occasioning a fourfold resistance, so that if it required 100 horse power to propel a vessel at the rate of 5 miles an hour, it would require 400 horse power to produce a speed of 10 miles per hour. This ratio, however, applies only to the resistance of the particles of the fluid in a quiescent state, and also assumes that the area of the immersed section is the same at all velocities; but the progress of vessels is influenced by various other causes, besides the inertia of the water, as tides or currents, and the force of the wind and sea; resistance from these causes has little or no relation to the speed of the vessels, and will require a certain amount of power to overcome them, independent of that which is required to overcome the inertia of the water; and the greater the amount of the resistance from the former causes in proportion to that from the latter, the more will the result vary from the theoretical calculation. In some circumstances, therefore, the consumption of fuel may be even less in going a given distance with large engines than with small ones. Let us suppose that a vessel, fitted with engines of 100 horse power, will go 10 miles an hour in still water, and that another vessel with 50 horse power will in the same circumstances go 7 miles per hour; if these vessels have to stem a current of  $4\frac{1}{2}$  miles per hour, the effective speed of the first will be reduced to  $5\frac{1}{2}$  miles per hour, and that of the second to  $2\frac{1}{2}$  miles per hour; the former, therefore, would perform a distance of 100 miles in 18 hours, and the latter in 40 hours; and as the large engine would only consume twice as much fuel per hour as the small one, it would consume in 18 hours only as much fuel as the smaller would in 36 hours, and, consequently, the consumption would be as 36 to 40 in favour of the larger power. But independently of these casual resistances, the resistance from the inertia of the water is found not to increase as rapidly as the square of the velocity; from the circumstance that with a considerable increase of speed, the vessel has a tendency to rise from the water, or diminish her draught, so that the area of the immersed section becomes less, and the head wave also decreases. This circumstance may appear paradoxical, but it seems to be well ascertained by a careful observation of facts, both in this country and in America. The *Great American Steam Raft* is stated frequently to have attained a speed of 20 miles per hour, at which time her draught of water was 7 inches less than when still, and there was no head wave. The same facts have been elicited by numerous experiments in this country with boats upon canals and drawn by horses, and will be found to be noticed in the experiments of Sir J. Robinson and Mr. Russell, of which we have already given extracts.



From the foregoing considerations, which have been confirmed by experience, the proportion of the power to the tonnage in seagoing steamers has been gradually augmented; vessels recently built having generally engines of greater power than old vessels of the same tonnage. Small engines are also frequently removed from vessels, and others of greater power substituted for them, with decided advantage, not only as to speed, but also with respect to the economy of fuel; their consumption per voyage, or for the same distance, being less with the large engines than it had previously been with the smaller ones.

The measured tonnage of a vessel, however, affords rather an uncertain criterion of the comparative amount of power required, as, from the improper mode of estimating the sizes of vessels or measuring them still in practice, a small vessel may be made to measure a great deal, and a large vessel may be made to measure very little. In all steamers, the vessel displaces considerably more than the measured tonnage.

Mr. Morgan, who has had considerable experience in this matter, and who has paid great attention to this subject, in his evidence before the committee on steam communication with India, assumes the displacement of the vessel as a better standard, and for vessels going long sea voyages deems 1 horse power to 4 or 4½ tons displacement a good proportion. He, however, advocates building the vessels of a sharper form than is generally done, so as to make the measurement and displacement nearly accord. We select from this gentleman's evidence the dimensions of some of the government steam packets, which will show the great discrepancy between the measurement and displacement.

*The Flamer.*—156 feet in length; 26 feet 8 inches beam; depth, 15 feet 3 inches; measured tonnage, 496½ tons; nominal power, 120 horses.

	TONS.	
Her hull weighs . . . . .	300	} Tonnage, 590. {
Her engines . . . . .	120	
Provisions, stores, masts, anchors, &c. . . . .	30	
Coals . . . . .	140	

With this displacement, she draws 11 feet 5 inches aft, and 10 feet 10 inches forward, in sea-water, and the area of her midship section, immersed, is about 225 feet.

Her cylinders are 42 inches in diameter, with a 4-foot stroke. Her wheels (Morgan's) are 18 feet in diameter, and 5 feet 6 inches wide.

When the vessel is deep, her wheels revolve . . . . .	} {	from 14 to 20 times per minute in heavy weather, and 25 times in light weather.
When the vessel is light, their speed increases . . . . .		from 18 to 22 revolutions per minute in heavy weather, and from 26 to 26½ revolutions in light weather.

*The Columbia.*—129 feet in length; 24 feet 6 inches beam; and 15 feet in depth; measured tonnage, 360 tons; nominal power, 100 horses.

	TONS.	
Her hull weighs . . . . .	250	} Tons, 494. {
Her engines . . . . .	104	
Provisions, stores, masts, anchors, &c. . . . .	30	
Coals . . . . .	110	

With this displacement, she draws 12 feet 6 inches aft, 11 feet 4 inches forward, in sea-water, and the area of her midship section, immersed, is about 213 feet.

Her cylinders are 39 inches in diameter, with a 3 feet 6 inch stroke. Her wheels are 17 feet in diameter, and 5 feet 2 inches wide.

When the vessel is deep, her wheels revolve . . . . .	} {	from 14 to 20 times per minute in heavy weather, and from 20 to 25 times in light weather.
When the vessel is light, their speed increases . . . . .		from 16 to 22 times per minute in heavy weather, and from 26½ to 28 per minute in light weather.

*The Firefly*.—156 feet in length; 28 feet 2 inches beam; depth, 17 feet; measured tonnage, 560; nominal power, 140 horses.

	TONS.		
Her hull weighs . . . . .	330	}	Tons, 715.
Her engines . . . . .	150		
Provisions, stores, masts, anchors, &c. . . . .	35		
Coals . . . . .	200		

{ With this displacement, she draws 12 feet aft, and 11 feet 4 inches forward, in sea-water, and the area of her midship section, immersed, is about 270 feet.

Her cylinders are 44 inches in diameter, with a 4 feet 6 inch stroke. Her wheels are 18 feet in diameter, and 9 feet 2 inches wide.

When the vessel is deep, her wheels revolve . . . . .	}	from 17 to 19 times per minute in smooth water, and from 6 to 12 per minute in heavy weather.
When the vessel is light, their speed increases . . . . .		from 20 to 21 revolutions per minute in fine weather, and from 8 to 14 in heavy weather.

The displacement certainly offers a better standard than the measured tonnage for estimating the power required in steam vessels; but we think the area of the immersed transverse section is the best basis of calculation; for, upon this the resistance chiefly depends. Thus, a steam-boat which has been lengthened generally sails faster with the same engines than before; because, although her measured tonnage is thereby increased, yet, from drawing less water, the area of the immersed transverse section is diminished.

In the three examples just given, the sectional area is to the horse power as follows:

<i>Flamer</i> . . . . .	1.9	feet area to 1 horse-power.
<i>Columbia</i> . . . . .	2.13	” ” ”
<i>Firefly</i> . . . . .	1.6	” ” ”

A fair proportion seems to be from 1½ foot to 2 feet section per horse-power, according to the nature of the service for which the vessel is intended.

**Construction.**—In regard to the mode of constructing and fastening steamers, much diversity of practice exists; but, generally speaking, strength and durability are not sufficiently studied; and, although improvements are taking place in this respect, much remains to be done. In order to give a general notion of this branch of the subject, we shall insert some extracts from the specification of a steamer of 600 tons burthen, built for the City of Dublin Steam Packet Company. It was furnished by C. W. Williams, Esq., the managing director of the Company; and the improvements recommended are those which, from the long experience of the Company, will admit of no doubt of their efficacy.

Mr. Williams recommends generally—

1. That the hull be divided into at least five separate compartments, by four iron-plate water-tight bulkheads, or partitions, so as to confine the water or fire to the compartments in which either may have originated.
2. The substituting of copper or composition bolts, with nuts and screws, in the fastening of the planking, and other parts, in place of tree-nails, the use of which should be entirely exploded.
3. The addition of hanging iron knees, properly constructed, with stays under the main and middle deck beams, wrought and fitted with care, according to prepared drawings; also, a continuous connexion of iron staple knees, by which the entire series of deck beams are firmly bound together, and to the sides of the vessel.
4. The adoption of an improved garboard strake, cut from a solid baulk, and fitted to the rabbet of the keel. Mr. Lang has lately done much towards introducing this valuable improvement.
5. The attaching the sister kelsons and sleepers, on which the engines and boilers are placed, firmly to the bottom of the vessel, by a proper system of

bolts, passed through the flooring and bottom planking, and by lateral stayings; these sister kelsons passing the entire length of the vessel. This mode of strengthening a steamer is very little in use.

6. The introduction of powerful longitudinal wrought-iron stay-bolts, four at least, and from  $1\frac{1}{2}$  to  $2\frac{1}{2}$  inches diameter, running the entire length of the main-deck, and through all the main-deck beams, properly secured to each with washers and cotters on the fore and after side of each beam; so that each deck-beam be not only thus tied together, but that each shall bear its due proportion of any strain of the vessel endways in a heavy sea. These iron longitudinal bolt-stays have been introduced with great advantage into several steamers, which had previously worked considerably in a sea-way.

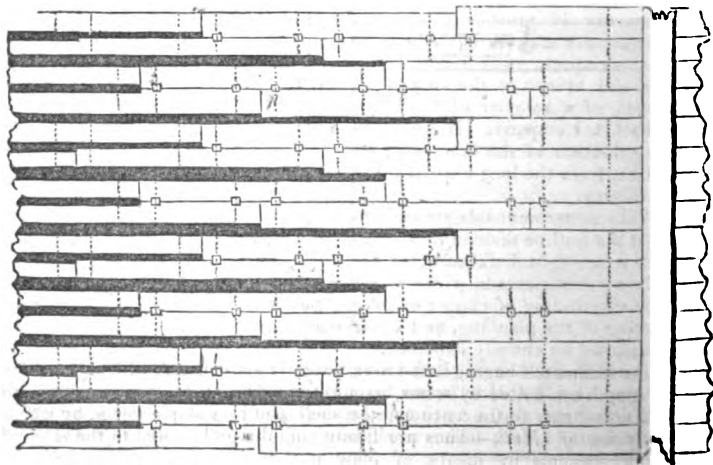
7. The introduction of an inner lining of sheet lead under the lining of sheet iron, and next to the skin of the vessel, to prevent the desiccation and charring of the timber bottom and sides, which the excessive heat and the decomposition of the fine powder of the coal in the neighbourhood of the engines and boilers frequently occasion. This under-sheeting of lead has been found an effectual remedy.

8. The use of iron in the various hatchways, ceilings, and scuttles, instead of timber, which latter weakens the deck of a vessel, whereas the former strengthens it.

9. The introduction of longitudinal cast-iron beams in lieu of wood, the entire length of the boiler hatchways, and to which is attached a wrought-iron deck-plate, the full size of the boiler hatchway. These iron beams secure that vulnerable part of the deck from contraction, sinking, or fire. The wood beams and deck usually adopted over the boilers contract instantly, and thus admit water to the top of the boiler.

10. The preparing the entire timbering, planking, decks, &c. on Kyan's or other anti-dry-rot principle, thus securing the greatest durability to the hull. This steeping process is effected in the builder's yard, and under the especial superintendence of a competent individual on the part of the owners.

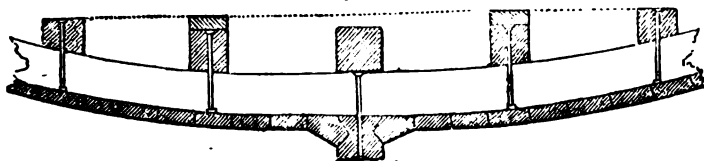
*Fig. 1*



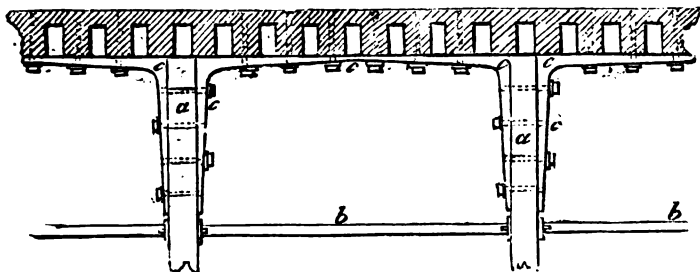
*Fig. 1* exhibits a plan of the solid floor, timber, and futtocks, with cogues and bolts; the black parts denote spaces which are to be filled in solid, and the dotted lines denote the bolts.

*Fig. 2* is a section of the keel and garboard strake with bolts.

Fig. 2.

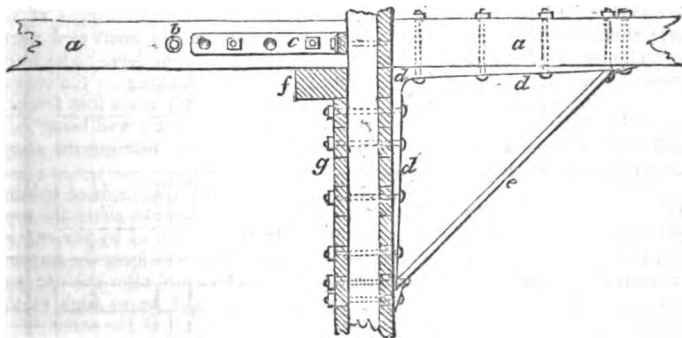


The following engraving is a horizontal section of a portion of the frame at the main deck, with staple knees, and longitudinal iron stay bolts.



*a a* are the deck beams; *b b*, an iron stay bolt,  $2\frac{1}{2}$  inches diameter, running the whole length of the vessel; there are four of these bolts; they pass through every beam, and are raised up on each side of the beam, and the beams being laid close enough to support the decks, carlings are not required; *c c*, the horizontal staple knees, secured to the sides and beams with screw bolts and nuts.

Subjoined is shown a vertical section of the hanging knee and stay, which supports the outer end of the main deck beam.



*a* is the main deck beam; *b*, the longitudinal stay bolt; *c*, the staple knee; *d*, the hanging knee bolted by screw bolts to the side and to the main deck beam; *e*, the diagonal stay to the knee; *f*, the shelf piece; *g*, the inner planking.

*Subdivision of Hull.*—The subdivision of the hull into separate watertight compartments by means of plate iron bulkheads calls for particular notice. The following observations by Mr. Williams will show the importance of this improvement, and an effectual method of carrying it into practice.

“The casualties to which ships (especially steam vessels) are liable arise, for the most part, first from striking against or coming in forcible contact with rocks, or such solid bodies as would injure the frame-work of the vessel; and,

secondly, from accidental collision with other vessels, by which some part of one, or both, becomes so damaged as to admit the water to such an extent as to overcome the power of the crew to pump it out.

"That any expedient shall be discovered which will prevent the irruption of the water to an extent beyond what may be within the power of men and pumps to expel, is hopeless. Even in the event of running on an anchor, or other body, which should break any part of the ship's bottom or side, or of a single plank starting, the extent of the injury would most likely be such as to render it impossible to keep the vessel afloat by human power. It occurred to me, that the only practicable expedient for preventing the sinking or actual submersion of the entire vessel would be by confining the effect of the injury sustained to that portion or section of the vessel in which the injury occurred; and this is the basis of the plan I am now to submit. The plan of dividing the vessel's hull into sections, each of which should be completely water-tight, has, we are told, been practised by the Chinese in their trade barges. This mode of giving security first occurred to me on building the iron steamer *Garryowen* (now plying on the Shannon at Limerick), and the trade barges which the Dublin Company's steamers tow on that river. Where the hull was of iron, as in the *Garryowen*, the introduction of iron plate bulkheads was easy and effective; and, independently of the great strength afforded by this internal and sectional bridging (as it may be called), these sections were as susceptible of being made water-tight as the hull itself.

"Experience has proved that it is impossible to make a timber partition or bulkhead water-tight, or, at least, that it should continue so. The heat of the vessel is sufficient to cause such a shrinking in a partition of timber planking as to render it wholly useless in preventing water from passing. Iron plate partitions, however, possess all the requisites for this effectual division of the vessel into so many water-tight compartments. Their introduction, then, into timber vessels appeared an important desideratum. The only parts where water could find its way from any one section when filled to another section not so filled, would be, not through the iron partitions, but at the sides and bottom of the vessel, where they come in connexion with the frame and planking of the vessel. The preventing the water from passing in this direction is effected by very simple means, viz. by making this part of the vessel solid, that is, without those rooms or spaces which intervene between the frames of the vessel; this solid framing should extend 18 inches before and abaft each partition. The mode of effecting this is familiar to all shipbuilders. The introduction of hair-felt between this solid framing and the planking on the outside and the ceiling on the inside completes the operation; the plate iron forming the partition having proper diagonal stays to give it strength, and being connected at the sides and bottom with angle iron, accurately fitted to the shape of the vessel, particularly in passing over the keelsons."

With regard to the number of these bulkheads, Mr. Williams is of opinion that four bulkheads, dividing the vessel into five compartments, afford the most eligible arrangement. The centre section will then be occupied by the engine, boiler, and coal bunkers. The section next to the centre will form the fore and after holds; or in the case of passenger vessels, the fore and after cabins; and the two remaining sections at the bow and stern need not be so high as the main deck, as the water never could rise within several feet of the same.

To prove the efficiency of these bulkheads, Mr. Williams tested the plan experimentally, under the inspection of the members of the British Association, in a new vessel, the *Royal Adelaide*. The vessel was first bored in the bow section, and the water allowed to flow freely in. When so filled that the water remained at the same height, outside and inside the section, it depressed the vessel at the bow six inches, and raised the stern about two inches. The water was then pumped out, and the adjoining section filled; this depressed the bow 12 inches without perceptibly raising the stern.

*Iron Bulkheads.*—Here, then, we have an effectual remedy against the casualties attending on a vessel coming into collision with another. Unless the

water break into the vessel in all the sections at the same time (which is almost impossible), there can be no danger of submersion. These bulkheads afford, also, a protection against fire. The circumstance of any part of an ordinary vessel taking fire is followed by the rapid spreading of it through all parts of the vessel. An instance of this calamity occurred recently to the steamer, the *Medway*, on the river Thames, where the only resource that remained to the numerous passengers was the confining themselves to that part of the deck most distant from the fire until the vessel was run on shore. These iron bulkheads, being air-tight, effectually prevent the introduction of any draught or current of air, so much to be dreaded. Again, in extinguishing the fire in the section in which it originated, the crew would be enabled to work in comparative security. The fire, being prevented spreading laterally, can only make progress upwards towards the deck, and which will be considerably retarded, if not altogether checked, by the absence of all current of air from either end of the vessel. Indeed, it is questionable whether the mere closing down the hatches over the section would not entirely extinguish it. These bulkheads have been adopted in many vessels belonging to the City of Dublin Company, and other parties have since followed their example, although the plan is far from being so extensively adopted as it deserves to be. With regard to the additional weight and expense, they are trifling in comparison with their importance and the security which they afford. Mr. Williams states that the bulkheads in the *Royal William* and *Athlone* cost £290 each vessel; and the additional timber in the solid framing must be trifling.

*Mr. Lang's System.*—The following plan of building steamers has been introduced with great success by Mr. O. Lang, of H. M. Dockyard, Woolwich.

Upon the keel being laid (say for a vessel of 300 tons),  $1\frac{1}{2}$  inch oak plank is passed diagonally, at an angle of  $45^\circ$ , from one side under the keel up to the plank share on the other side. At the fore and after ends, from the rise of the floor, the planks cannot be passed under, and are rebated into the keel. The first planking is caulked and payed; then a second range of planking,  $1\frac{1}{2}$  inch thick, at an angle of  $45^\circ$ , is laid on the first, with patent felt between, crossing the direction of the angle, and this second planking is again caulked and payed. Then the third row,  $1\frac{1}{2}$  inch thick, is put on longitudinally, with felt between, like the ordinary planking of a vessel, and caulked and payed  $\frac{1}{4}$  inch through; bolts are used, and clenched upon ruffs such as boat-builders use. Bent timbers are then placed inside, at every four feet apart, with small floor timbers for carrying the sleepers. The following vessels, now running upon the Thames, are built upon this plan,—*Ruby*, *Gem*, *Diamond*, *Duchess of Kent*, *Topaz*, *Prince George*, *Fairy*, *Naiad*, *Ariel*, and *Nymph*.

*Iron Vessels.*—Owing to the many advantages attending the construction of vessels made entirely of wrought iron, excepting the decks, a decided preference is now given to them, and they are fast becoming almost universal. Amongst the numerous advantages may be mentioned,—

1. An iron vessel does not weigh half so much as a wooden one of similar dimensions; consequently draws much less water.

2. An iron vessel affords much more room for stowage, owing to the decreased thickness of its sides; those of the latter not exceeding four inches, including the angle iron ribs to which the plates are fastened; while those of a wooden vessel of the same dimensions are not less than twelve inches thick. Thus a wooden vessel, of 24 feet beam outside, would be only 22 feet inside; whilst an iron one would be 23 feet 4 in.; making a difference of 16 inches all round; which difference, in a vessel measuring 150 feet long, 24 feet beam, and 16 feet deep, affords room for the stowage of 80 tons more of cargo than the wooden vessel.

3. Owing to the diminished draught, or the necessity of displacing a less weight of water, an engine of equal power to that on board a wooden one will propel it much faster, or one of less power equally fast. In the latter case, there is effected a proportionate saving of fuel; in the former, a saving of both time and fuel.

4. Iron vessels are much cooler, owing to the metal being a rapid conductor of heat.

5. The air in the holds of iron vessels is much purer, not being contaminated with foul bilge-water, as is the case with wooden ones.

6. They are less liable to leak; and the leak, when made, more easily stopped, the fracture or hole being generally much smaller, and capable, usually, of being beaten back into its former position.

7. Iron vessels do not, like wood, become heavier by saturation.

8. Iron vessels are not subject to be affected by lightning, that fluid being conducted into the water by the metal.

9. Owing to the greater tenacity of the metal, iron vessels may be constructed of greater dimensions than wood.

The first iron steam vessel built for sea was the *Alburkuk*, constructed by Mr. Laird to take part in the expedition to the Niger, conducted by Mr. Laird. Her dimensions were,—length, 70 feet; breadth, 13 feet; depth, 6 feet 6 in. The plates in her bottom were only  $\frac{1}{2}$  inch thick, and those in the sides only an eighth. When launched, she drew but 9 inches of water; with her engine, boiler, and various fittings, about 3 feet 4 inches. Her weight, including the decks, was 15 tons. The engine, of 15 horse power, and boiler, added about 15 tons more.

The foregoing exhibits an example of one of the smallest iron vessels, and the following affords a magnificent specimen of the *largest* iron vessels hitherto constructed.

The *Great Britain*, having a tonnage of 3443, by the old measurement, was built at Bristol by the same Company which brought out the *Great Western*, the largest wooden steam vessel previously produced. The *Great Britain* was chiefly constructed under the direction and management of Mr. Thomas Guppy, with whom was connected Mr. Isambard Brunel, as consulting engineer. The length of the keel of this noble vessel is 289 feet; total length, 322 feet. Her beam or breadth is 51 feet; depth, 32 feet 6 inches. Her draught of water when loaded, 16 feet. Displacement, 2984 tons. The ribs are of angle iron, 6 inches by  $3\frac{1}{2}$ ,  $\frac{1}{2}$  and  $\frac{1}{8}$  thick. Distance of ribs from centre to centre amidships, 14 inches, increasing to 21 inches at the ends.

Ten iron sleepers run from the engine-room, (gradually diminishing in number to the fore end of the ship,) and under the boilers, the platform of which they support. In midships they are 3 feet 3 inches in depth, supported by angle irons in the form of inverted arches, a short distance from each other.

She has five water-tight partitions; stows 1200 tons of coal; has a space for 1000 tons of measurement goods. The engines weigh 340 tons, the boilers 200 tons, and they hold 200 tons of water.

The main shaft is 28 inches in diameter in the centre, and 24 inches in the bearings; in the rough, before it was turned, it weighed 16 tons: it was lightened by a hole of 10 inches diameter, bored throughout. A stream of cold water is caused to flow through this hole and the cranks while the engines are at work.

The screw shaft consists of one long, and two short, or coupling parts. The part next the engine is solid, 28 feet long, by 16 inches in diameter. The hollow intermediate shaft is 65 feet long, and 32 inches in diameter. The screw part is 25 feet 6 inches long, and 16 inches in diameter. The total length of this shaft is 130 feet, and weighs 38 tons. The screw has six arms, 15 feet 6 inches in diameter, and weighs 4 tons.

The main drum is 18 feet diameter, and drives 4 chains, weighing 7 tons. The screw shaft drum is 6 feet diameter, and the weight with the pull when working is equal to 85 tons on the bearings of the main shaft.

The steam cylinders are four in number, 88 inches in diameter, and with a stroke of 6 feet. The condensers are of wrought iron, 12 feet by 8, and 5 feet deep. Under the whole space occupied by the engines up to the top, the angle irons are doubled.

The upper main and saloon decks are of wood, the two cargo decks are of iron. The officers and seamen are all accommodated on two decks under the

forecastle. She has six masts fitted with iron rigging. Five of the masts are hinged for lowering during contrary gales. She is provided with seven life-boats, capable of carrying 400 people. She is built with lapped joints in preference to flush, the former having been proved, to the satisfaction of the Company, to be one-fifth stronger than the latter mode.

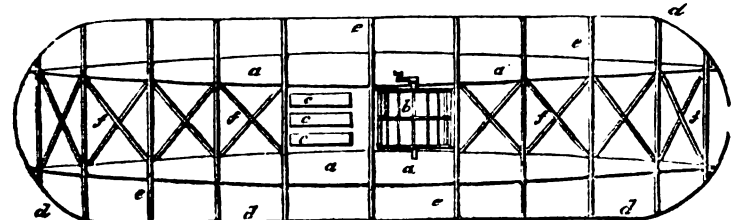
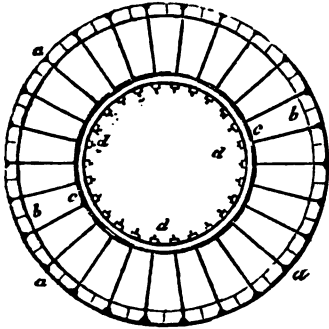
In each of the five compartments, the engine pumps, by means of pipes and cocks, can be applied. The water-tight divisions of each compartment add greatly to the strength of the ship, either as struts or ties.

We shall conclude this section by a notice of what are called **TWIN BOATS**, of which there have been several constructed both in this country and America. These vessels are composed of two floating bodies placed side by side, but some distance asunder, and connected together by a deck extending over both, and the paddle-wheel is ordinarily single, and placed in the middle. The chief object proposed in this construction is to obtain great speed by employing vessels of very great length and comparatively small transverse section, and, therefore, calculated to experience but little resistance from the water, and at the same time to obtain increased lateral stability. The plan, however, has not, upon the whole, been found to succeed: one objection we understand to be, that the water, not being able to escape laterally, accumulates in the space or channel between the vessels, and materially increases the resistance. Twin steam boats were employed for several years on the Tay ferries, but have since been superseded by vessels of the ordinary construction. The largest twin steam vessel ever built was the *Great American Steam Raft*, which was formed of two separate hollow trunks, or spindles, with a deck laid over them. These trunks were 300 feet long, and in the centre, or thickest part, were 8 feet in diameter, tapering in a regular parabolic curve to a point at each end. The paddle-wheel, which was 30 feet in diameter, worked in the space between the trunks. We do not know what was the power of her engines. The marginal

figure is a cross section of one of the trunks. *a a a* are the staves, 26 in number, and  $3\frac{1}{2}$  inches thick, to each of which is attached an iron bolt, *b b*, 26 inches long, passing through the staves, and countersunk on the outside of them. These bolts pass through an iron ring, *c*, on the inside of which they are screwed up by nuts, *d d* so that the staves are brought into very close contact; sufficient room is left in the centre for a man to enter and pass fore and aft, and turn the nuts, if necessary.

The annexed figure shows the plan of the beams connecting these two spindles, or trunks, upon which the decks are built: *a a* the trunks or spindles; *b* the paddle-wheel; *c c c* the boiler; *d d* the beams guard; *e e, f f*, the braces. This vessel

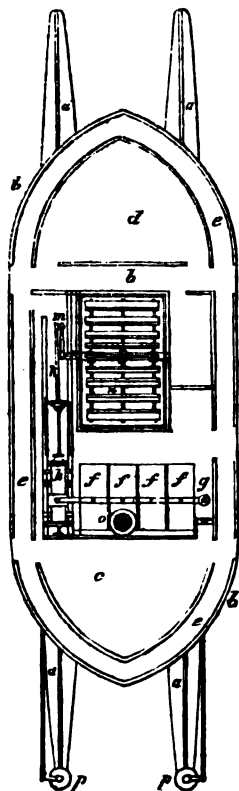
was built at New York; was destined to ply between that city and Troy,



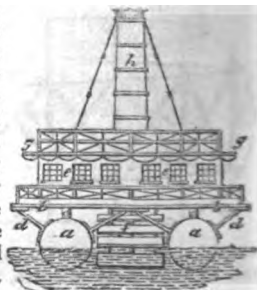
distant about 160 miles up the Hudson. It is said, that on her first trip she ran 21 miles in 61 minutes, and that her average speed was about 20 miles per



hour; the greatest *authenticated* speed *at sea* was, however, only 14 miles per hour. At anchor her draught of water was 24 inches, but when running at her greatest speed it was stated to have decreased to 17 inches. After making a few voyages she was unfortunately lost by running upon a bank off the city of New York, where she speedily went to pieces. In 1837, Mr. Neil Snodgrass, of Glasgow, obtained a patent in this country for an invention similar to that of the *American Steam Raft*, but with improvements in the details. His plan is to form the buoyant vessels, which support the superstructure in which is contained the cabins and machinery, of sheet iron, the form of the buoyant vessel to be cylindrical at the middle portion of the length, and at about one-third of the length from each end to taper off conically. To prevent the loss of buoyancy which might arise from leakage, each of these vessels is divided transversely into separate compartments, of about four feet each in length, made air and water-tight, by forming them at first in separate lengths, and riveting them together on hoops of angle iron. To stiffen the entire vessel, four malleable iron bars are riveted thereto equidistantly and longitudinally their whole length, and along the upper side of each vessel is a beam of wood, which extends the whole length of the lower deck, and to which the whole of the joisting and beams for supporting the decks and machinery are bolted. The paddle-wheel to be placed in the channel between the floating vessels, and at about five feet before the centre of the vessels' length. In order to give a clearer idea of the minor details, we extract the marginal figure from his specification: it is a plan of the vessel on the lower deck:—



At *aa* are the conical vessels; *bb*, the lower decks laid upon transverse joisting; *c* is the chief cabin; *d* the second; *ee* promenade surrounding the cabins; *ff* four cylindrical boilers, which are all connected to one steam pipe, which is provided with a large safety valve at *g*, from whence there is a large tube to convey the waste steam into the water reservoir below. At the lower part of each boiler is a pipe provided with a two-way cock, either to feed or to blow off each boiler; and in the general steam pipe above are four valves, through which the steam passes from short vertical pipes, leading from each boiler; by shutting any one of these valves, and the feedcock beneath, appertaining thereto, such boiler may be detached, if required; *h* is the steam engine, placed horizontally, and connected by the rod, *k*, to the crank, *m*, on the end of the shaft of the paddle-wheel; *n* the funnel; *pp* rudders hung to the stern of each of the floating vessels. On the head of each rudder is fitted a yoke or crosshead, from which a rod or chain proceeds forward along the under side of the lower deck, where it is connected by any suitable means to the pilot's steering wheel, fitted on the upper decks, and in front of the boat. The annexed figure shows an end view of the boat. *aa* the floating cylinders; *bb* the lower deck, supported upon joists, crossing the sleepers, *cc*, and also by the diagonal stays *dd*, proceeding from the cylinders, *aa*; *c*, the cabins; *f* the paddle-wheel; *g* the upper deck, surrounded by a railing; *h* the funnel.

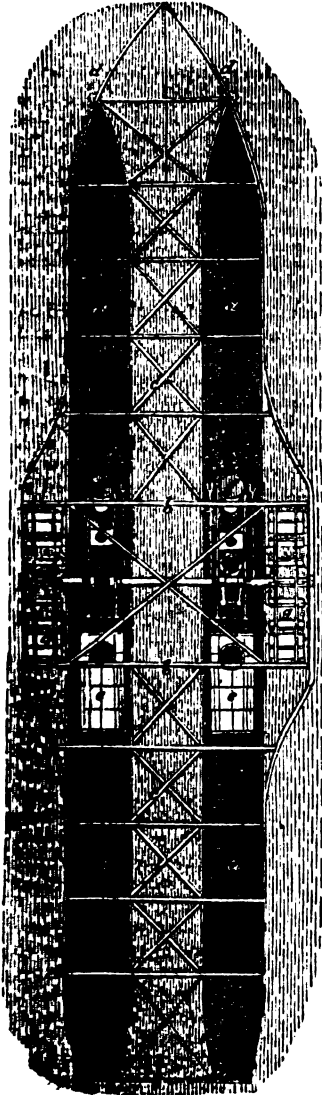


A small vessel on Mr. Snodgrass's plan, nearly resembling that shown in the figure, was constructed at Glasgow. We do not know whether she was finally successful, but we believe the first trials did not altogether realize the expectations which were formed of her performances. This might, in part, arise from the floating cylinder not being of sufficient dimensions to carry the upper works, for with merely the machinery on board, the cylinders were fully one half immersed.

About the same time Mr. Gemmell, of Glasgow, obtained a patent for improvements in steam vessels, part of which refer to the arrangements of the machinery on twin or double boats. Vessels of this description are generally propelled by a single wheel placed between the two boats, but Mr. Gemmell considered, that, owing to the rapidity of the current through this channel when the vessel is in motion, the paddles do not obtain sufficient reaction or resistance from the water to propel the vessel; he therefore proposed to employ two wheels, placing one at the outer side of each boat. The annexed figure is a plan of the boat and machinery:—*aa* are the twin hulls or boats, which are firmly united together by the beams *bb*, and the trusses *cc*. To avoid the liability, to which twin-boats are peculiarly subject, of having other vessels or objects running between the hulls, or of otherwise becoming entangled together, from the bows of the two boats is projected a guard, *dd*, which also serves greatly to strengthen the parts therein included. *ee* are the boilers; *ff* the engines; and *gg* the paddle-wheel.

We are not aware that any vessel has been constructed on Mr. Gemmell's plan, nor can we discover in it anything to recommend it. By placing the wheels on the outside of the vessel instead of the central channel, the extreme breadth of the vessel is augmented by the amount of the breadth of the channel, which, in the case of vessels plying on rivers, is a serious objection; and further, the paddle-wheels are no longer protected from collision with other vessels, but form the same dangerous and unsightly projections as in steamers of the ordinary construction.

It is somewhat singular that the first vessel propelled by steam in this country was a twin-boat, Mr. Miller's experiments being made in vessels of this description, which he had previously constructed without reference to the employment of steam as the propelling power.



## SECTION III.

THE CONSTRUCTION AND ARRANGEMENT OF MARINE ENGINES,  
BOILERS, CONDENSERS, &c.

**Peculiar construction of Marine Steam Engines generally.**—Beam Engine.—Lever Engine.—Napier's Direct Action Engine.—Seaward's Gorgon Engine.—Penn's Direct Action Engine.—Steeple Engine.—Galloway's Inverted Cylinder Engine.—Humphrey's Trunk Engine.—Parkyn's Sliding-cover Engine.—Maudslay's Concentric Cylinder Engine.—Maudslay and Field's Double Cylinder Engine.—Hick's Inverted Double Cylinder Engine.—Maudslay and Field's Direct Action Screw Propeller Engine.—Brunel's Inclined Cylinder Engine.—Penn's Oscillating Engine.—Boric's Rotatory Engine.—Condensation of Steam.—Seaward's Salt-water Gauge.—Maudslay and Field's Pumps.—Brunel's Condenser.—Napier's Condenser in the "Kilmun."—Howard's Condenser.—Dr. Church's Condenser.—S. Hall's Condenser in the "Wilberforce."—S. Hall's Salt-water Still.—Parallel Motion.—Reversing Motion.—Seaward's Slide Valves.—Morgan's Balance Valves.—Piston-slide Valves.—Expansion Valves.—Snodgrass's Expansion Valves.—Bourne's Slide Expansion Valves.—Ordinary Steam-boat Boiler.—Separate Elliptical Boilers.—Boilers of the "Syrius."—"United Kingdom" Boilers.—D. Napier's Tubular Marine Boilers.—Safety Valves.

MARINE engines, in general, differ in their construction from those used on land in several points. As the weight of the machinery of steam-vessels, and the space which it occupies, necessarily excludes a portion of the cargo, it becomes an object of the greatest importance to diminish that weight and space to the utmost degree compatible with the requisite stability and means of working. These essential qualifications should be sought for by the adoption of the most judicious forms for obtaining the greatest strength and solidity with the least quantity of material. Marine engines should also be as simple as possible, consistently with their efficient performance: as they are exposed to severer trials than any other class of engines, they are consequently more liable to derangement; and the delays and expense attending repairs become serious evils, as the profitable employment of the vessel is thereby suspended.

An important consideration is, the position of the centre of gravity, which should be placed as low as possible, in order to obtain the greatest degree of stability for the vessel; as a very slight heel or lateral inclination of the vessel materially increases the load upon the engines, and detracts from the speed.

From these and other considerations, the arrangements and proportions commonly observed in land engines require to be modified for marine purposes. The length of the stroke is much shorter in proportion to the diameter of the cylinder than is usual in land engines; the length of the stroke seldom exceeding the diameter of the cylinder by more than a sixth, and frequently being even less than the diameter. The beam likewise is shorter, being generally rather less than three times the length of the stroke; and instead of having only a single beam, the centre of which is placed considerably higher than the centre of the shaft, there are two beams working outside the side frames, and the centres are placed as low down as the vibration of the beam will admit, the connecting rod working upwards instead of downwards. This arrangement originated in Scotland, and, we believe, with Mr. David Napier, of Glasgow.

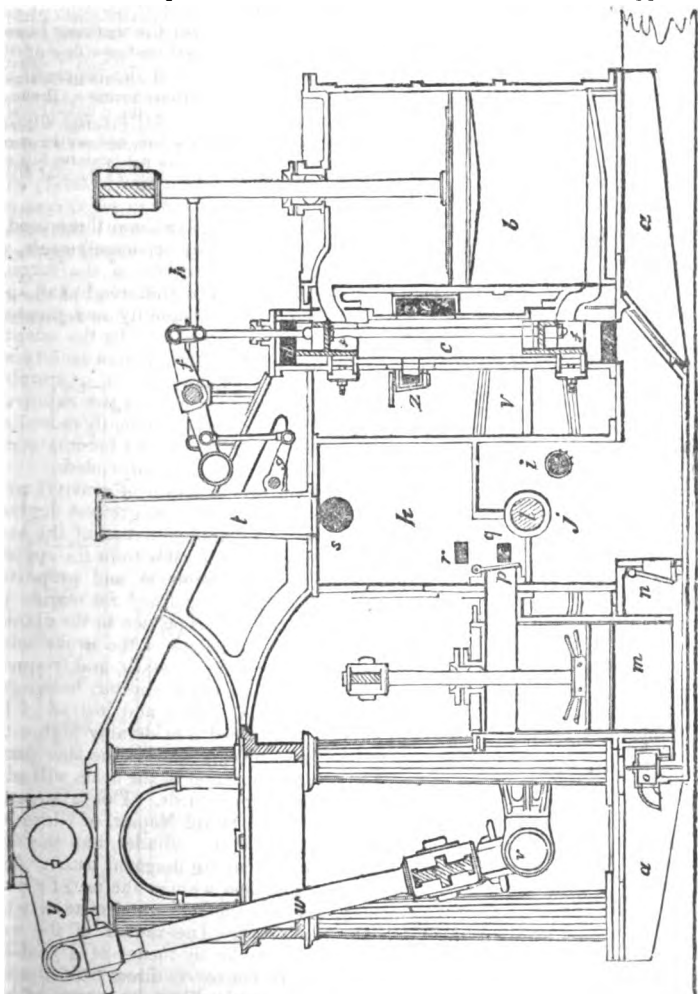
The shaft is considerably higher than the top of the cylinder, and the frame which carries it is braced to the cylinder by a strong diagonal truss. As an unlimited supply of injection-water can be obtained without the use of a pump, the cold-water pump is dispensed with, and also the cold-water cistern, which, in land engines, usually surrounds the condenser. The motion of the vessel precludes the ordinary mode of feeding the boiler by means of a feed-head and a regulating float; the water is therefore conveyed direct from the feed-pump to the boiler, and the supply is regulated by hand, by means of regulating valves or cocks.

Owing to the rapidly corrosive action of sea-water upon iron, whether malleable or cast, it is found necessary to construct all the moving parts of the engine which are exposed to it of copper or gun-metal; the air-pumps are

therefore lined, and the air-pump rods sheathed, with copper or gun-metal, and all the valves and cocks, and the plungers of the feed and bilge pumps, are made of brass or gun-metal.

Marine engines are generally of the class known as Beam Engines, in which the action of the piston is transmitted to the crank by a beam, whose fulcrum is in the centre of its length; we shall therefore commence our description with one of this class.

*Beam Engine.*—The annexed figure represents a longitudinal section. At *a* is the foundation-plate, on which the engines are erected; it is supported

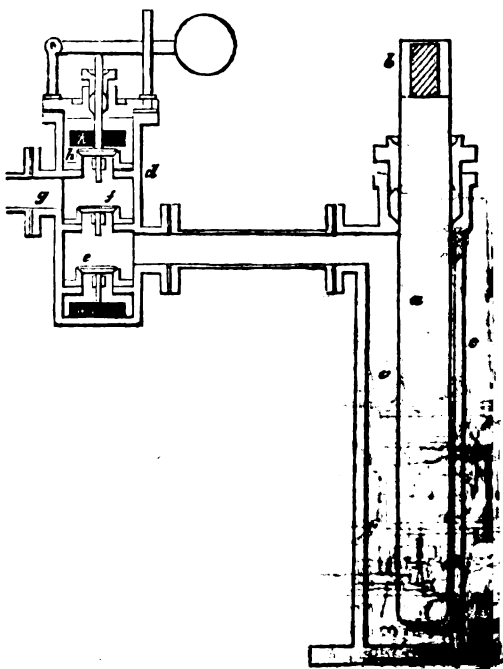


upon two deep sleepers of wood, which cross the floor-timbers of the vessel, to which they are firmly bolted. A portion of the bed-plate is formed into a channel, nearly as deep as the sleepers, part of which channel forms the bottom of the condenser, and another part receives the foot of the air-pump; *b* the cylinder; *c* the slide-case, which is formed of three vertical compartments,

connected at top and bottom by the apertures *d d*; the middle compartment forms the steam-chamber, and the side compartments are the eduction passages; *e* is the steam inlet; *f* the slide-valve, formed of two short alides, connected by a rod, which is found preferable to a single long slide for large engines, as the latter is liable to warp; the slides, which on the back form about one-third of a circle, are pressed up to the seats by screws at the back, acting upon a block of metal, faced with a thick sort of mat, made for the purpose; *f* the valve lever, working upon the shaft of the parallel motion as a fulcrum; the motion of the eccentric is communicated by the intermediate lever *g*; *h* the parallel bar; *j* the condenser, cast in one piece, with *k* the hot-well, and bolted to the foundation-plate; *i* the injection pipe. A tube, or cylindrical passage, is cast in the condenser, through which pass the gudgeons *l* of the working beam; these gudgeons are very securely wedged into bosses, cast on the sides of the condenser, and the brass bearings are fixed in a boss in the centre of the beam; *m* the air-pump; *n* the foot-valve; *o* the blow-through valve, through which the air and water are blown out of the condenser at starting the engine; *p* the delivery valve, through which the water passes into the hot-well; *q* the passage leading to the feed-pump; *r* the connexion with the relief valve; *s* the passage by which the waste water is carried off into the sea; *t* an air-vessel; *v* the beam; *w* the connecting rod; *y* the crank; *z* the blow-through cock, connecting the steam-chamber of the slide-case with the eduction passage; this cock is opened previously to starting the engines, for the purpose of expelling the air from the engines, or, as it is termed, *blowing through*.

The feed-pump and bilge-pump are worked from the cross-head of the air-pump, and could not be shown in the sketch. The annexed figure represents,

on a larger scale, a section of the feed-pump, with its valves. *a* is the plunger, attached to the cross-head *b*, and working through a stuffing-box in the pump-barrel *c*; *d* is the valve-box attached to the side of the hot-well; *e* is the suction-valve, through which the water is drawn from the hot-well into the pump by the rise of the plunger. On the descent of the plunger the water is driven out at the valve *f*, along the feed-pipe *g* to the boiler, unless the regulating valves or cocks on the boiler should be quite closed, when it raises the loaded valve *h*, and returns to the hot-well by the aperture *k*. The load per square inch on the valve *h* must somewhat exceed the pressure per square inch of the steam in the boiler.

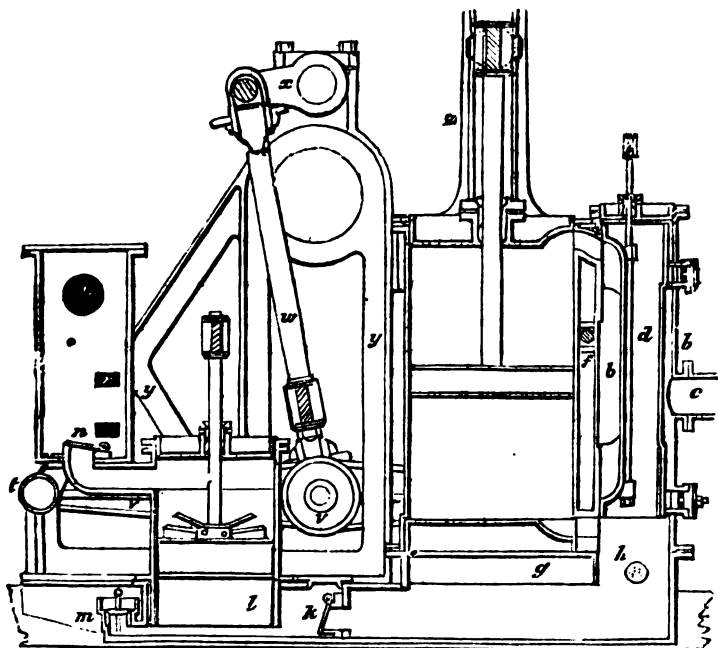


In addition to the bolts, by which the cylinder, condenser, and side-frames are screwed down to the foundation-plate, there are twelve strong bolts, called

holding-down bolts, which are passed from the outside through the foot-timbers, sleepers, foundation-plate, and bosses on the cylinders, condensers and side-frames, and screwed as firmly as possible by strong nuts. These bolts are of copper, or iron tinned, in order to resist the corrosion of the sea-water.

The arrangement of the Beam Engine is, perhaps, that which is best adapted for general use in steam-vessels, as all the parts admit of easy access; the weight of the moving parts on each side of the beam nearly counterbalance each other, and the requisite pumps are easily attached; but their weight and the space they occupy have, in the progress of the improvements which marine engines have undergone, been deemed very serious drawbacks; and, at present, opinion seems to be setting in favour of what are termed "direct-action" engines, most of the leading engineers having adopted each some particular arrangement for dispensing with the side-beams. Several of these deviations from the common form we shall now proceed to describe, commencing with one which may be considered as intermediate between the Beam and the Direct-action Engines; it is commonly termed a "Lever Engine," the action of the piston being transmitted to the crank by a lever, whose fulcrum is at the extremity.

*Lever Engine.*—The accompanying figure represents in section an engine of this class. *a* is the cylinder; *b* the slide-case; *c* the steam-pipe; *d* the slide, of the sort commonly known as the long side, which is hollow, and forms the eduction passage; *f* the way-shaft, by which the valve is worked; *g* is the con-



denser, cast in one with the bed-plate, and forming a pedestal to the cylinder; *A* the injection-pipe; *k* the foot-valve; *l* the air-pump, inserted in a chamber formed in the bed-plate; *m* the blow-through valve; *n* the delivery valve; *o* the hot-well; *p* the waste-water passage. The feed-pumps may be supposed to be arranged as in the engine first described, *q* and *r* being the passages connected with the pump; *s* is the beam gudgeon; *v* the beam; *w* the connecting-

rod;  $x$  the crank;  $y$  the side-frame, firmly secured to the bed-plate, and to strong flanges cast on the cylinder;  $z$  the guides in which the cross-head moves.

This arrangement appears to us to be inferior to the preceding one, and to possess few recommendations. Very little space is gained, or weight saved; and as no longer cylinder can be employed than with a Beam Engine, the crank of course must be shorter. In the Beam Engine, likewise, the parts acting on each half of the beam nearly counterbalance each other; but in the Lever Engine the weight of the steam and air-pump pistons, side-rods, and connecting-rod, acts all on one side of the fulcrum, and therefore requires to be counterbalanced, which is sometimes done by having one of the paddles of the wheel formed of cast iron, of the requisite thickness. Lever Engines are very common in boats on the Humber.

*Napier's Direct-action Engine.*—The annexed figure represents a Direct-action Engine, which in appearance greatly resembles the preceding, the small side-beams being retained; but solely for the purpose of working the pumps. It was applied by Mr. David Napier, of Glasgow, to the "United Kingdom" steam-vessel, at a period when it was considered as of great dimensions.

In the annexed engravings, *Fig. 1* represents an end view of the two engines, and *Fig. 2* a side view of one of them.

The cylinders  $a a$  are of cast iron, and fixed to a framing, which is bolted to the bottom of the boat. The piston-rods  $b b$  are keyed at the upper ends to the cross-heads  $c c$ ; to the exterior ends of which are attached the connecting-rods  $d d$ . The lower ends of these connecting-rods are inserted in the fork ends of the beams  $e e$ , which vibrate upon a shaft  $f$ , the bearings of which rest upon the top of the condenser  $g$ . In the same forks are inserted the ends of other connecting-rods  $h h$ , which are keyed at their upper ends to cross-heads  $i i$ . In the centre of these cross-heads are bosses large enough to receive the rods  $j j$ , which extend to the crank pins of the cranks  $k k$ . These cranks are fixed to the main shaft, which rests upon the bearings  $l l$ , upon the arches  $m$ , which are bolted to the cross-beam, as at  $n$ . The shafts are shown as broken off at the outer ends, but they extend to the outside of the paddle-wheel.

The side beams  $e e$  are not straight, but have two bends, represented by the lighter parts of the shading; the ends near the cylinder being therefore much farther apart than the opposite ends, so that they may take up as little room as possible, by lying close to the respective parts of the machinery. They are also forked at the end nearest the air-pump  $o$ , so as to admit the insertion of the pump-rods  $p$ , which are connected at their upper ends to the cross-head  $q$ , in a bush, in the centre of which is keyed the air-pump rod  $r$ . Connecting-rods  $s$  are attached at  $t$  to the side-beams  $e$ , and at their upper ends to cross-heads, which are connected, as at  $u u$ , (*Fig. 1*), to two rods, which work the plungers of two feed-pumps  $v$ , for supplying the boiler.  $j$  is the apparatus for blowing through, previous to starting the engine. It consists of a cock, which opens or closes a communication between the steam-chest and condensers, by turning the handle. The rod and lever  $x$  are for the purpose of regulating the quantity of injection water which enters into the condenser, by a pipe from the outside of the vessel, and can be increased and lessened in quantity by turning a cock to which the rod  $x$  is attached;  $y$  is the hot-well, into which the condensing water is discharged from the air-pump. The feed-pumps are supplied with water from this hot-well, through the medium of a pipe, the overplus being discharged through the side of the vessel by another pipe which is not seen.

*Seaward's Gorgon Engine.*—The annexed engraving represents an arrangement for a Direct-action Engine, devised by Messrs. Seaward, and commonly known as the "Gorgon Engine," from having been first employed in a government steamer of that name.  $a$  is the steam cylinder, and  $b$  the piston-rod, which is connected to the crank  $c$  by the connecting rod  $d$ . The head of the piston-rod is guided vertically by the parallel motion as follows:— $e$  is a rocking standard, carrying at its upper end the fulcrum upon which the beam  $f$  turns.

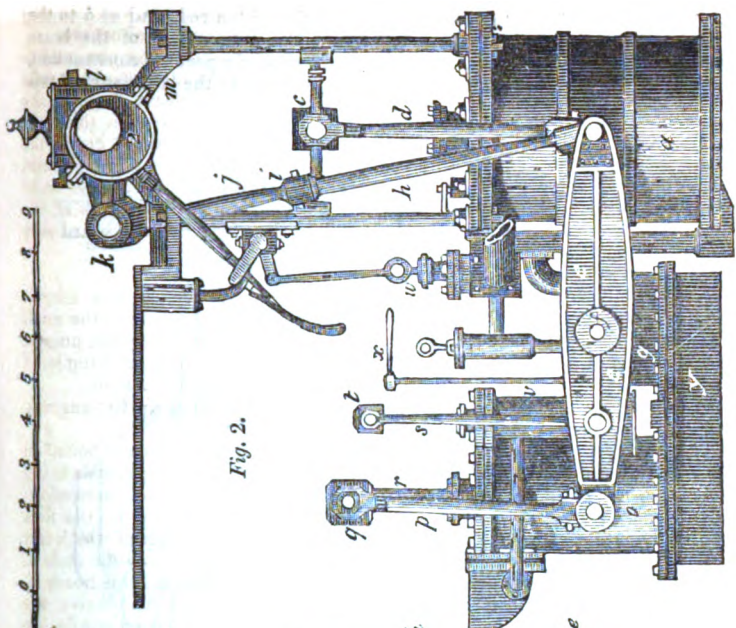


Fig. 2.

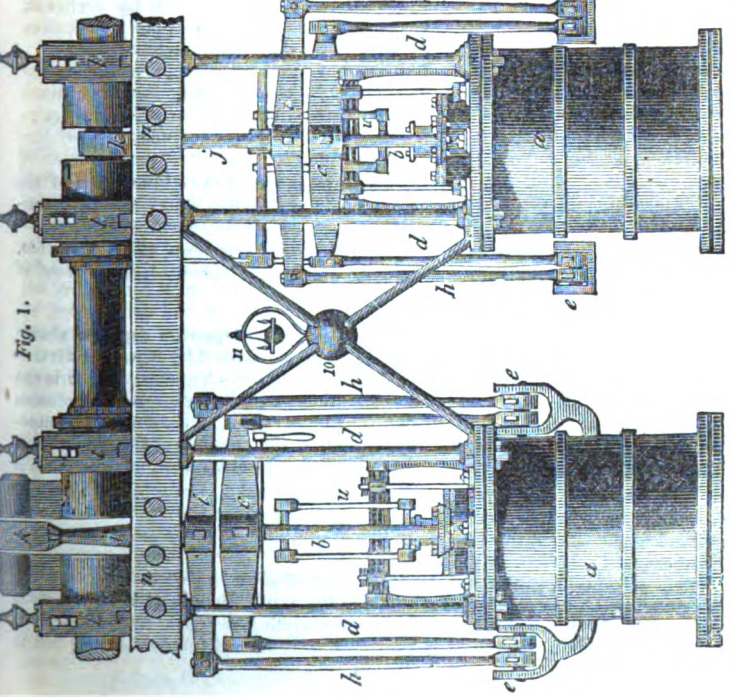
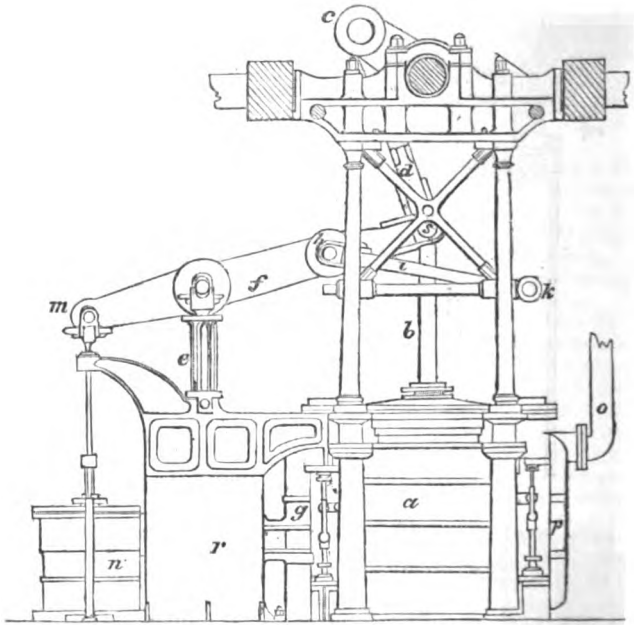


Fig. 1.

NAPIER'S ENGINE.



This beam is jointed at *g* to the cross-head of the piston-rod, and at *h* to the radius bar *i*, which turns upon *k* as a centre. The outer end *m* of the beam serves to work the air-pump *n*. The slide-valves are of a peculiar construction, patented by Mr. Seaward, and which will be described in the latter part of this

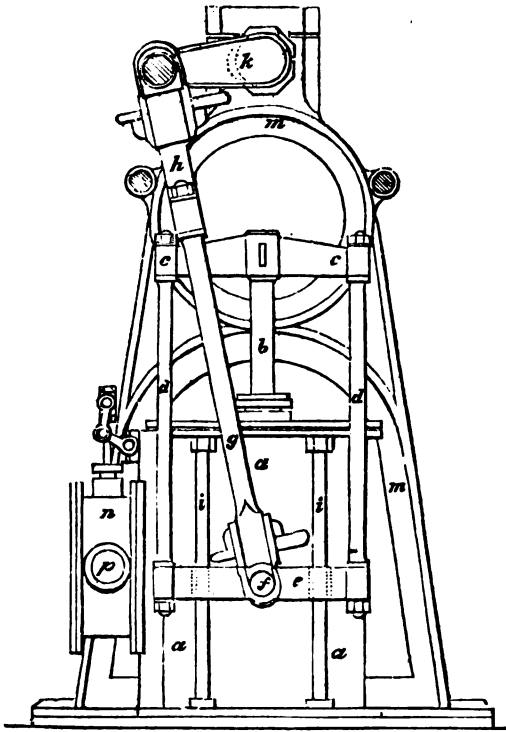


article. *o* is the steam-pipe, by which the steam enters the slide-case *p* of the induction slides; and *q* is the slide-case of the eduction slides, which is connected with the condenser *r*, the upper portion of which forms the hot-well.

Messrs. Seaward have constructed several pairs of engines of this description, of large dimensions, for the government, which may be considered a proof of the efficiency of the plan.

*Penn's Direct-action Engine.*—This arrangement of marine engines, shown in the opposite engraving, originated, we believe, with Mr. Penn, of Greenwich, who has applied it to some steam-boats on the Thames. At *a* is the cylinder; *b* the piston-rod, carrying the cross-head *c c*; this cross-head consists of four arms, branching diagonally from the centre. On each side two side-rods *d d* are suspended from the extremities of the arms *c c* of the cross-head, and are attached at the lower end to a bar *e*. In the centre of this bar is a pin *f*, to which the forked end *g* of the connecting-rod *h* is coupled; *i i* are two guide-rods, upon which the bar *e* slides, the rods passing through brass bushes attached to the side of the bar; *k* is the crank, and *m* the side-frame; *n* the slide-case, and *p* the steam-pipe.

When only one engine is employed, instead of a forked connecting-rod the rods *g* are sometimes connected directly to the crank, the pin of which is equal in length to the distance between the two connecting rods *g*. By this means a longer stroke may be obtained in the same height, and the connecting rod is somewhat lighter.

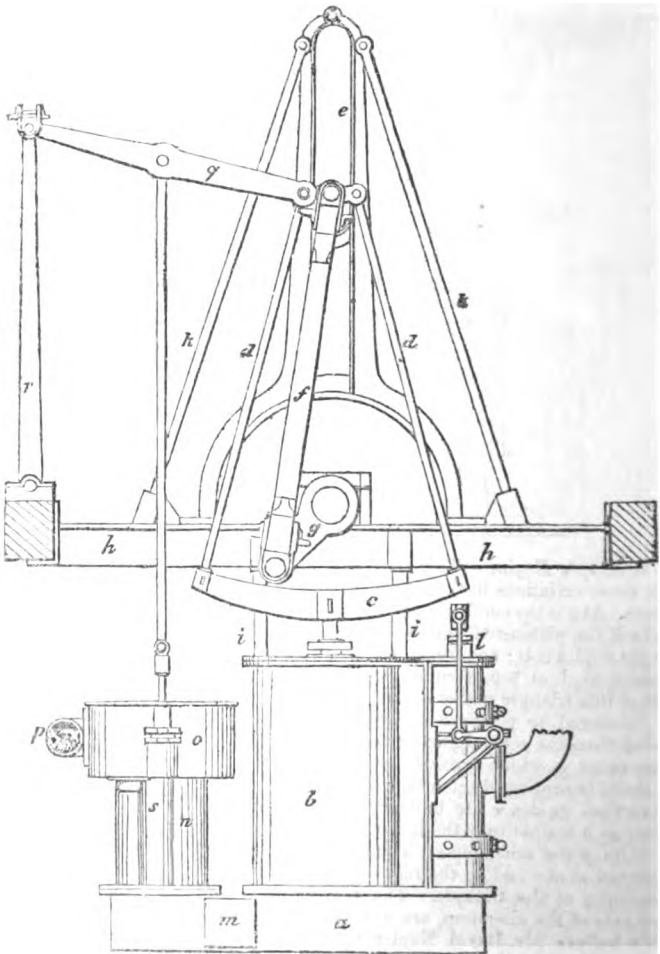


*The Steeple Engine.*—This arrangement is extensively adopted on the Clyde, with some variations in the minor details, according to the views of different makers. At *a* is the condenser, constituting the base of the cylinder *b*. the cross-head *c* of the piston-rod, instead of being parallel to the shaft, as is usual, stands at right angles to it; and from the ends of the cross-head rise two rods *d*, which are connected at top, forming with the cross-head a triangle. Through the apex of this triangle passes a pin, the ends of which work in guides *e*, to cause the piston-rod to preserve a parallel motion. The connecting-rod *f* is suspended from the central part of the pin, and the lower extremity is connected to the crank *g*, which revolves within the triangle. The frame *h*, which carries the shaft, is supported upon four short columns, which rest on the cylinder; and the vertical guides *e* are braced to this frame by the rods *k*; *i* is the slide-valve; *m* a bonnet over the foot-valve: *n* the air-pump; *o* the hot-well on the top of it: *p* the waste pipe. The air-pump is worked by the beam *g*, which is supported at one end by the rocking standard *r*, and at the other is connected to the apex of the triangle. The feed-pump *s*, and the bilge-pump on the other side of the air-pump, are worked from the cross-head of the air-pump.

We believe Mr. David Napier introduced the plan of suspending the connecting rod above the crank in steam vessels, but Trevithick employed a similar arrangement in his steam-carriage in 1802.

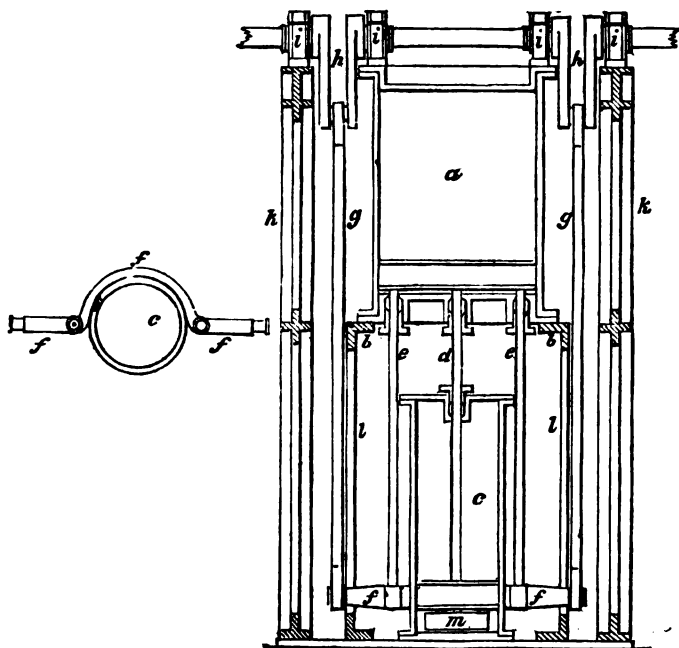
The motion for the air-pump, shown in the sketch, (p.692) is not that which is commonly employed, but is the best which we have noticed. Sometimes the air-pump is worked from one end of the cross-head of the piston-rod, and the bilge-pump and feed-pump from the opposite end; and in some vessels the slide-valve is at the side of the cylinder, and two air-pumps, of small diameter, are worked from the extremities of the cross-head.

This arrangement, like that of the Oscillating Engine, admits of a long stroke, without carrying the shaft very high; and the parts in motion being few, the friction is proportionately small. It has, however, some serious disadvantages; a considerable weight lies at a great height above the centre of gravity; the oblique thrust of the connecting-rod acts with some leverage against the upper framing; and the engine-house requires to be carried above the deck.



*Galloway's Inverted Cylinder Engine.*—The engraving on the opposite page exhibits an arrangement for marine engines for which Mr. Elijah Galloway obtained a patent; and which has, we believe, been adopted in one or two vessels plying on the Humber. At *a* is the cylinder, supported upon the frame or platform *b b*; *c* is the air-pump, placed beneath the cylinder, and concentric with it: the piston-rod *d*, of the air-pump, passes through a stuffing-box, in the cover of the air-pump, and through another stuffing-box in the

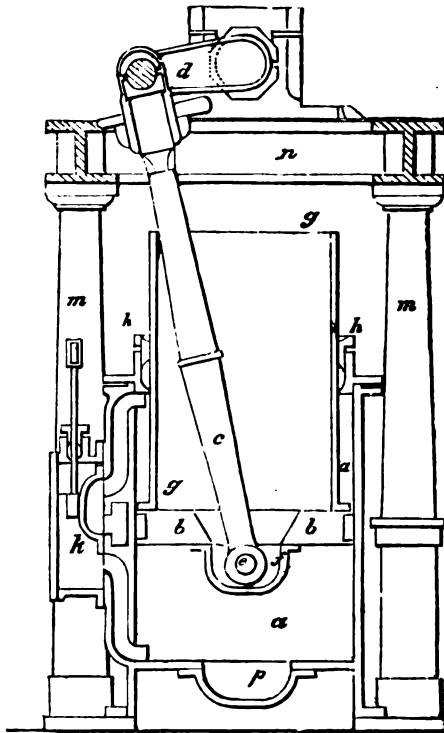
bottom of the cylinder, and is attached to the steam piston. Two piston-rods, *ee*, pass down through stuffing-boxes in the bottom of the cylinder, and are keyed into a cross-head, *f*, which is curved so as to encompass one half of the air-pump, as shown in the plan separately given of it; *gg* are two connecting rods proceeding from the bearings of the arms of the cross-head to the crank



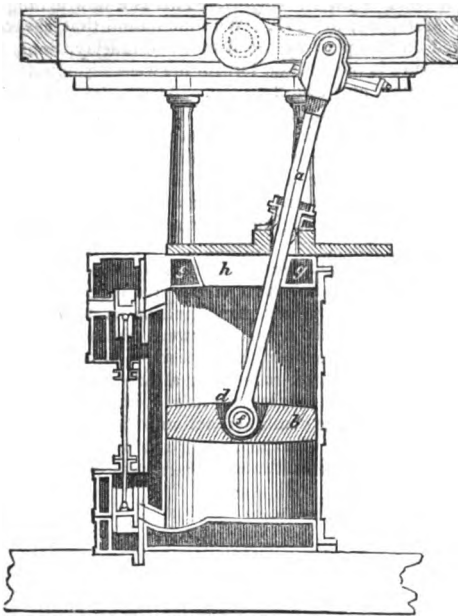
*kk*; *iiii* are the plummer blocks, which carry the paddle shaft; two of these are supported by the cover of the cylinder, and the other two by the side frames *kk*; *m* is the neck in which is placed the foot valve, connecting the pump with the condensers; *ll* are the guides in which the cross-head *f* works.

*Humphery's Trunk Engine.*—Mr. Francis Humphery obtained a patent in 1835 for an arrangement in which not merely the side beams, but likewise the piston-rod was dispensed with: the power of the engine being transmitted direct from the piston to the crank by the connecting rod. To this novel form of engine he gave the distinguishing name of the Trunk Engine: it is remarkable alike for originality, simplicity, and ingenuity. The annexed cut (p. 694) represents a vertical section of the engine. *a* is the cylinder; *b* the piston; *c* the connecting rod, the upper end of which is connected to the crank *d*, and the lower end passes through an aperture in the piston, and carries a pin, *e*, the ends of which work in bearings attached to the under side of the piston; *f* is a bonnet enclosing the bearings and end of the connecting rod. The connecting rod works within a case or trough, *g*, which is bolted at bottom to the top of the piston, and which slides in a stuffing-box, *h*, on the cylinder cover. The sides of the trough are straight, and parallel to each other; and the ends are semicircular; the width is just sufficient to receive the connecting rod without rubbing, and the distance between the semicircular ends is such as to allow the vibration of the connecting rod during the revolution of the crank. *k* is the slide valve, and *m* the columns supporting the entablature *n*, which

carries the plummer blocks, in which the shaft revolves; *p* bonnet, covering the manhole in the cylinder bottom. A pair of engines of this description, 90 horse-power, were constructed by Messrs. J. & E. Hall, for a packet named the *Dartford*.



*Parkyn's Sliding-Cover Engine.*—The adjoining cut is explanatory of a direct-action engine invented by Mr. Parkyn, which resembles the preceding in the circumstance of the piston-rod serving also as the connecting rod, but by a somewhat different disposition. *a* is the rod which serves at once the purpose of the ordinary piston rod and connecting rod, being attached at the lower end to the piston *b*, and at the upper end to the crank pin *c*; *d* is a recess in the piston *b*, for the reception of the lower end of the rod *a*; *e* a cross pin passed through the body of the piston *b*, and the eye-hole *f*, in the lower end of the rod *a*, turning freely upon the pin. The motion of the crank and connecting rod *a* being angular and variable, while the piston *b* moves uniformly in one vertical plane, in order to bring the two motions into harmony with each other, the following arrangement is adopted. In the centre of the cylinder cover *g*, and in a line parallel with the crank, there is an elongated slit, *h*; and immediately over this there is a supplementary steam-tight cover *i*, which moves backwards and forwards at right angles to the main shaft, in conformity with the varying positions of the crank and connecting rod *a*, much in the same way as in a lathe the tool carriage of a slide-rest moves on its bed. The under portion of the stuffing-box has two arms or pins, which turn in suitable bearings in the upper or supplementary cover *i*, whereby the stuffing-box is enabled to adapt itself to the line of the piston and connecting rod throughout the entire revolution of the crank.



PARKYN'S ENGINE.

Fig. 1.

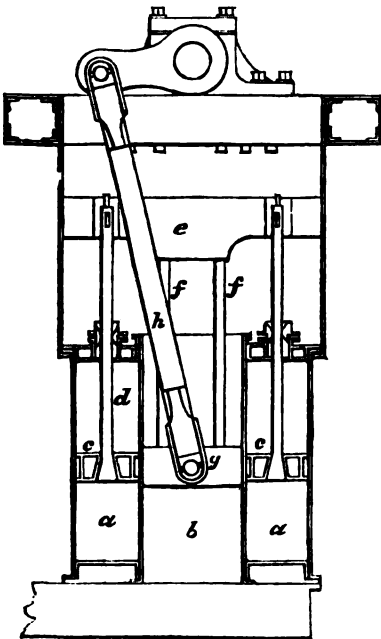
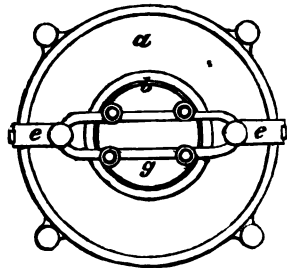


Fig. 2.

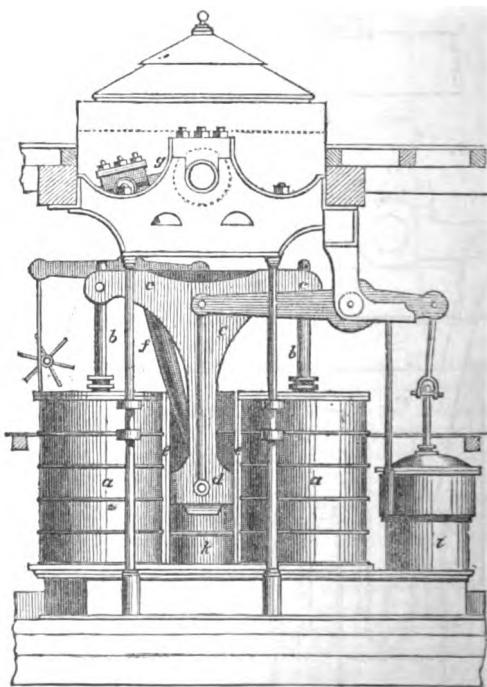


MAUDSLAY'S ANNULAR CYLINDER ENGINE.

*Maudslay's Annular Cylinder Engine.*—This is a new arrangement, patented by Mr. Joseph Maudslay, in 1841. We understand that several engines have been constructed on this plan by the firm of Maudslay, Sons, and Field. Its distinguishing feature is the annular form of the working cylinders. *Fig. 1* (p. 695) is a sectional elevation, and *Fig. 2* a plan. At *a* is the exterior steam cylinder; *b* a smaller cylinder, fixed in the centre of the steam cylinder; *c c* the piston, of an annular form, and working in the space between the two cylinders; *d d* the piston-rods; *e* the cross-head; *f f* rods uniting the cross-head with the guide block *g*, which moves in the cylinder *b*. From a pin in the guide block, the connecting rod *h* is connected with the crank. The air-pump and other parts may be attached to the engine in various convenient ways.

*Maudslay and Field's Double Cylinder Engine.*—The peculiarity of this engine consists in there being two steam cylinders, each of half the area necessary for the intended power, combined so as to form one engine, and placed so far apart, as to leave a space between them for the connecting rod, and the lower end of a T-shaped cross-head, to which the connecting rod is attached, to work in; the piston-rods being attached to the horizontal extremities of the T cross-head, and moving up and down simultaneously with it and with each other, whereby the combined action of both pistons is applied to one crank of the paddle shaft. In the accompanying drawings *Fig. 1* exhibits a longitudinal elevation of one of the engines, consisting of two steam cylinders

*Fig. 1*



worked by one slide valve, as shown at *k* in the plan *Fig. 2*. *Fig. 3* exhibits a transverse section of a portion of the vessel, with one of the engines in elevation. At *a a*, *Fig. 1*, are the two connected working cylinders; *b b* their piston-rods, the upper ends of which rods are affixed by keys to the cross-head

ccc; at the lower end of the cross-head there is a slider *d*, working between ribs *ee*, fixed on the outer surfaces of the cylinders; to this slider *d* one end of a connecting rod *f* is attached, the other end of that rod being attached to the crank *g* of the propelling shaft.

From this arrangement it will be perceived, that by the simultaneous ascent and descent of the two pistons in their working cylinders *aa*, the rods *b b* will

Fig. 2.

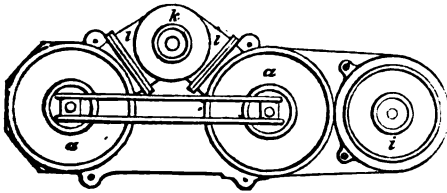
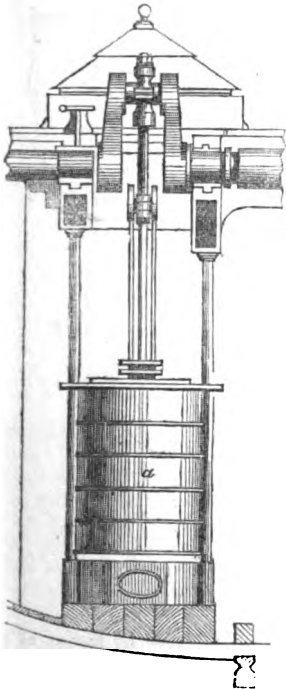


Fig. 3.



cause the cross-head *cc* to move perpendicularly up and down between its guide bars *ee*, and in so doing to raise and depress the slider *d* with the connecting rod *f*, which rod will by that means be made to give a rotatory motion to the crank *g*, and thereby cause the paddle-wheel shaft to

revolve. The air-pump, and the feed and bilge-pumps are worked by the lever *m*, which is connected to the slider *d* by the rods *n*.

The mode of adapting the steam valve to the combined cylinders is shown in *Fig. 2*. The steam is admitted to, and withdrawn from, these cylinders by one slide valve *k* common to both, through a pipe, in the ordinary way; the steam passing through the curved passages or tubes *ll* into both cylinders. There is also a narrow passage of communication always open, by which the steam is allowed to pass from one cylinder to the other, for the purpose of keeping the pressure equal at all times in both cylinders.

The advantages stated to be realized by this arrangement are: 1. Simplification of construction; 2. More direct action on the crank; 3. Saving of space and weight of material; and 4. Obtaining the greatest length of stroke and connecting rod in a given height, without any lateral pressure on the pistons or piston-rods.

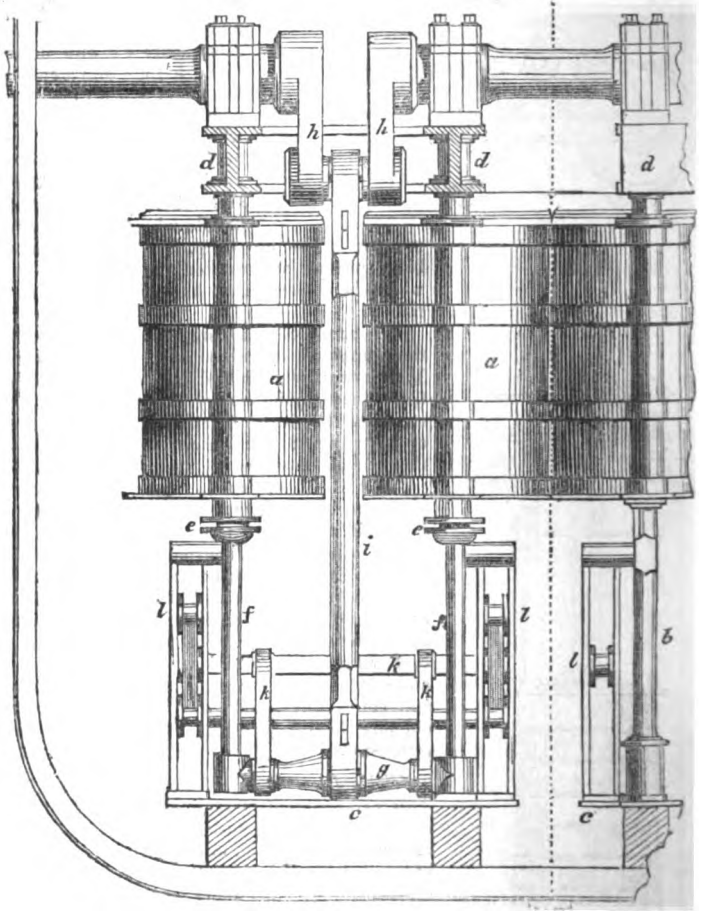
*Hick's Inverted Double-cylinder Engine.*—

This arrangement resembles the preceding one by Messrs. Maudslay and Field in the circumstance of each engine being composed of two cylinders, but in all other respects it is different. The cylinders in this engine are inverted, and the four cylinders composing the pair of engines are ranged in a line across the vessel. The engraving shows a transverse section of a portion of one side of the vessel, with an end view of

the engines. At *aa* are the cylinders, standing upon four strong wrought-iron columns, only one of which is shown, in order to bring the piston-rods into view. The columns rest on, and are secured to, the foundation plate *c*; and passing through suitable bosses on the sides of the cylinders support the entablature plate *d*, and the crank pedestals above. The cylinders are placed at a sufficient height from the bottom of the vessel, to allow the piston-rods to work downwards. The two piston-rods *ff* are connected



together by a cross-head *g*; the stuffing-boxes *ee* are of double form, or in other words they have a space for packing both at top and bottom, being furnished with self-acting oil cups for lubricating the rods. The power is transmitted directly from the main cross-head *g* below to the cranks *h h* above the cylinder, by the connecting rod *i*; the two piston-rods *ff*, and the connecting cross-head

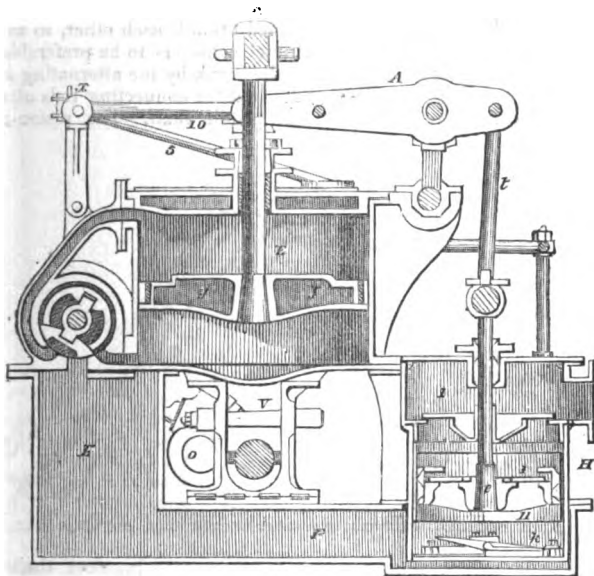


*g*, are further secured and made to work uniformly together by means of a strong vibrating frame *k* of cast iron, forming part of the parallel motion; and which, with the side levers *l*, serves also to work the air-pump as well as the feed, bilge, and brine-pumps. Each cylinder is furnished with a separate slide valve, the two being connected together by a cross-head, worked by one eccentric motion. The object of thus dividing the valve is to shorten the lengths of the steam ports; the valves being brought much closer up to the face of their respective cylinders than would be the case if one only were used for both. The condenser is placed immediately underneath the slide valve case, and the air-pump, foot, and discharge-valves, are similar in construction to those of ordinary engines. The air-pump and condenser are connected together by a

passage underneath the foundation plate. The waste water is discharged from the hot-well by an overflow-pipe through the side of the vessel.

*Maudslay and Field's Direct-action Screw Propeller Engine.*—This engine is chiefly designed for dispensing with the multiplying wheels, or chains and drums, hitherto employed, between the engine crank and the shaft of the screw propeller, in order to produce a suitable speed in the latter.

The annexed figure represents a transverse vertical section of the engines; they are ranged side by side in a line coincident with the line of the propeller shaft, and immediately over the engine shaft, which is concentric with the propeller shaft, and is connected thereto by a coupling, which admits of the shafts being readily disconnected, when the vessel is required to be propelled by the sails alone. In order to obtain the requisite speed, the engines are constructed

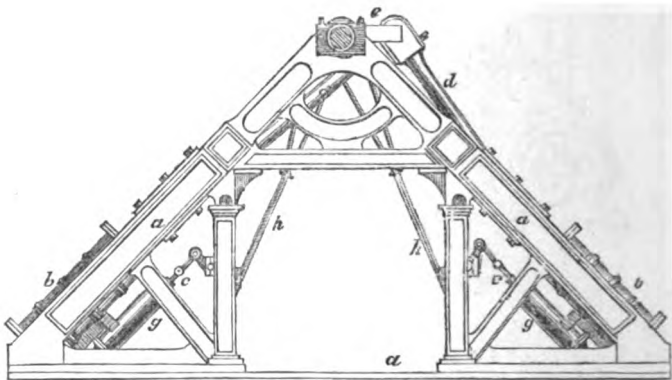


to work with a very short stroke, and a new kind of slide valve is employed, which facilitates the rapid exhaustion of the cylinder. At *aa* is the cylinder, supported on the upper part of the condenser *b*, and on a projecting flange on the air-pump *c*; *d* is the engine shaft; and *e* one of the engine cranks keyed thereon, to which the force of the piston is transmitted from the cross-head *f* of the piston rod, by the connecting rod *g*. The slide valve is composed of a hollow segmental plate *h*, working in a flat prolongation of the condenser *k*; the space above the slide plate being occupied by the steam, and the cavity on the under side of the plate communicating with the condenser by the passage *m*. The valve works on its axis with a vibratory motion, and thus brings each side of the piston into communication alternately with the steam and the condenser.

The foot of the air-pump is inserted in a flat prolongation of the condenser; and the foot valve *n* is situated in the bottom of the pump. The delivery valves *o* and *p* in the bucket and pump cover are composed of annular plates, which rise and fall vertically between guides, and admit of the escape of the air and water, both at the periphery, and at the central aperture of the annular plate. The upper portion *q* of the air-pump forms the hot well, from which the supply for the boilers is drawn by the feed pumps; and the surplus passes off by the waste water-pipe, which is connected to the aperture *r*. The air-pump is worked from the parallel motion in the following manner: *s* is the parallel bar,

which is connected at the end *t* to the cross-head *f*; and at the point *v* to the radius rod *w*, the centre of motion of which is at *x*. The parallel bar is extended beyond its centre of motion to *y*, from which the cross-head of the air-pump is suspended by links, or a connecting rod *z*. The feed and bilge-pumps are connected to the cross-head of the air-pump.

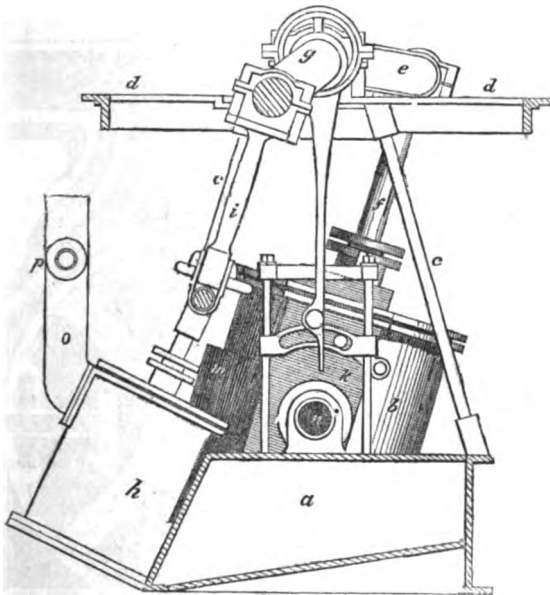
*Brunel's Inclined Cylinder Engine.*—This arrangement was patented by Mr. Marc Brunel in 1822, and he employed an engine on this plan for pumping in the great subterranean work of the Tunnel under the Thames. It has likewise been adapted in several steam boats. The chief improvement consists of an arrangement of the working cylinders, by which the connecting rods of two engines are made to give motion to the same crank. The annexed figure, which represents an elevation of the engine, will afford a correct idea of it. At *aa* is a strong triangular frame of cast-iron: within are fixed the two cylinders *bb*. These cylinders are inclined towards each other, so as to form an angle of  $102^{\circ}$ , which angle Mr. Brunel considers to be preferable to any other for imparting a rotatory motion to the crank by the alternating action of the piston-rods; *cc* are the piston-rods; *dd* the connecting rods attached to the crank *e*, which gives motion to the paddle shaft. The piston-rods are



supported upon rollers, running upon guide plates to preserve their parallel motion during the stroke. The steam is received from the boilers into the small cylinders *g g*, and by the action of the pistons therein is alternately admitted into one end of the working cylinders, and a passage opened for its escape at the other. The action of the piston is regulated by the eccentrics placed on the paddle shaft, as shown in *Fig. 2*. These eccentrics give motion to the rods *h h*, which, by the intermediate levers *i i*, operate upon the pistons in the small cylinder. This arrangement, it will be seen, is better suited to high-pressure engines than to condensing ones, as it affords no convenient mode of working the air-pump. In a French Post-office packet, on the Dover Station, the engines were somewhat similarly arranged; the two engines impelling one crank: but the cylinders were on the oscillating principle.

*Penn's Oscillating Engine.*—But of all the arrangements of direct action engines, that which admits of the greatest length of stroke in the smallest compass, and which, perhaps, is also the simplest, is the Oscillating Engine, invented, as we have already mentioned, by Mr. Witty. The very extensive adoption of this form of engine for steam vessels, is mainly owing to the example of Messrs. Penn and Son, of Greenwich, who for some years past have employed it in preference to all others; and, by their judicious mode of construction, added to the exquisite style of workmanship, have attracted such notice to the arrangement that most of the leading engineers have to some extent adopted it; and it bids fair to supersede most other forms.

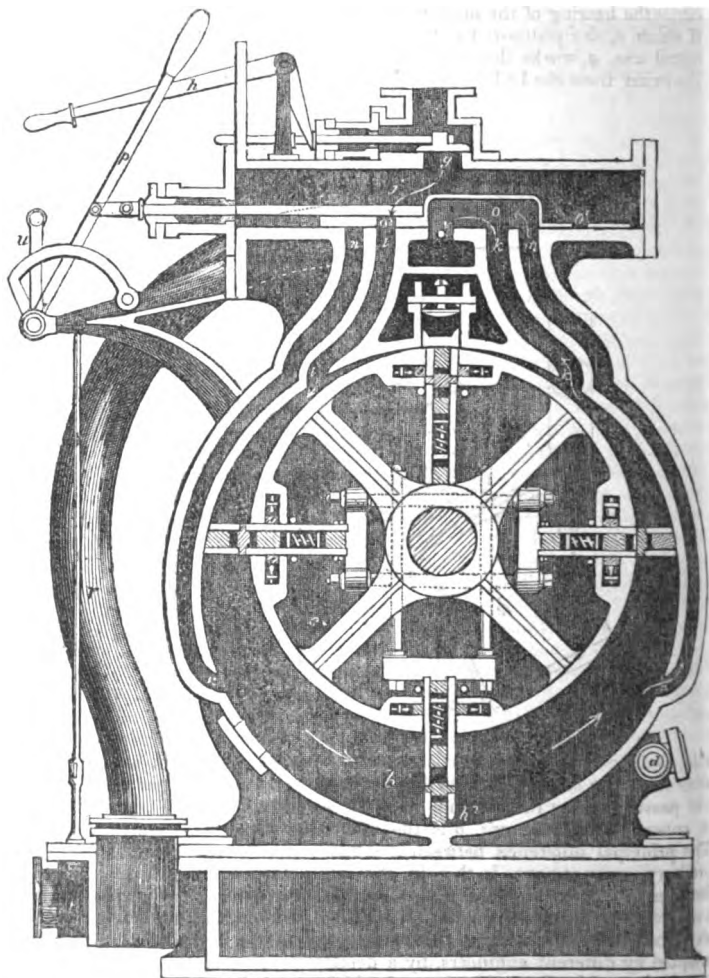
The annexed cut represents an arrangement of this description of engine adopted by Messrs. Penn in a vessel on the Thames, which differs slightly from their ordinary management. The foundation or bed plate of the engine is composed of a strong cast-iron frame, extending across the vessel, and divided into three compartments; the two side ones being occupied by the cylinders, and the central one *a* forming the condenser; *b* is one of the cylinders, which is suspended upon hollow axes or gudgeons, working in bearings attached to the bed-plate; *cc* are wrought-iron pillars, supporting the top frame *d*, that carries the bearing of the main shaft, which is formed into three cranks, to one of which, *e*, the piston-rod *f* of the steam cylinder *b* is connected, whilst the central one, *g*, works the air-pump *h* by the medium of the connecting rod *i*. The steam from the boiler enters by the gudgeon which is nearest the vessel's



side, and arrives at the slide-case *k* by the hollow passage or belt *m*. By the slide valve the steam is admitted to the cylinder, and discharged from the same, and passing off by the midship gudgeon *n*, which forms the eduction passage, it enters the condenser; *o* is the hot well, and *p* the waste water-pipe. The principal difference between the arrangement described and Mr. Penn's ordinary arrangement, is that in the latter the air-pump stands vertically between the two engines, and that the slide valve case is placed at the back of the engine, that is to say, midway between the two gudgeons. We shall conclude our account of the varieties in the form of marine engines adopted by different engineers, by a description of a rotatory engine recently invented by Mr. Peter Borrie, and which, we believe, has been applied to several vessels.

*Borrie's Rotatory Engine.*—The accompanying engraving is a transverse section of this engine through the centre of the cylinder. At *a* is the foundation plate, to which all the parts of the engine are directly or indirectly attached; *b* is an external cylinder fixed to the foundation plate; *c* is a small cylinder, revolving within the external one, on a shaft *d*, whose centre is placed so far above that of the external cylinder, that their circumferences may touch one another

at the upper point  $h^1$ ; and the space between them thus gradually increases from  $h^1$  to the lower point  $h^2$ . The shaft  $d$  passes through steam-tight stuffing-boxes in the cylinder ends, and revolves in bearings in the frames, which are firmly bolted to the foundation plate, and stayed to the cylinder;  $e e$  are two sliding pistons, consisting each of two arms, connected together by four rods passing over the shaft. Their breadth is equal to that of the outer cylinder, and their joint length over their extremities is necessarily somewhat less than

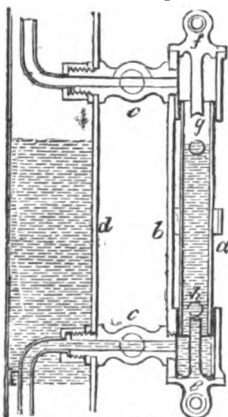


its diameter, owing to the eccentricity of the revolving cylinder. These pistons slide freely at right angles to one another, through passages made in the circumference of the revolving cylinder, their sliding motion being caused by the pressure of one of their extremities on the ascending side of the outer cylinder (whichever side that may be); and the eccentricity of the revolving cylinder, through which they slide. As their length is always slightly varying during the course of a revolution, the difference is made up by metallic packing placed

between the two thicknesses of plates, of which the arms of the pistons are composed. This packing is pressed by springs towards the sides and circumference of the outer cylinder, as will be readily understood by reference to the figure. In the passages in the inner cylinder, through which the piston slides, there are also metallic packings, which are pressed on the flat surfaces of the pistons by springs, and prevent the steam passing to the interior. There are, besides, two steel rollers at the inside of the packings, which are pressed up to the flat sides of the pistons by screws, for the purpose of diminishing the friction of their sliding motion; but these rollers are not necessary, except in large engines. The rim of the inner cylinder is made to project into metallic packing-boxes in the cylinder ends, whereby the steam is entirely prevented from passing into the interior of the inner cylinder. A packing-box is also placed at the point of contact to prevent the steam passing to either side. From what has been stated, it will be perfectly understood, that the steam only acts on the projecting part of the sliding pistons between the inner and outer cylinders. The steam, in coming from the boiler through the steam pipe *f*, has first to pass the slide *g*, which is worked by the handle *h*. After passing that slide, it enters the steam-tight jacket *j*, the bottom of which is the slide face, having the four cylinder ports *k l m* and *n*, and the eduction port *g* on it. A slide *o*, worked by a handle *p*, passes over these ports for the purpose of reversing the motion of the engine; on this slide there are two ports, *o*<sup>1</sup> and *o*<sup>2</sup>. In the position in which the slide is shown in the engraving, the port *o*<sup>2</sup> is open to the steam port *l*, the port *n* is closed, and the two ports *m* and *k* are open to the eduction port *g*; so that when the slide is in this position, the engine will necessarily move in the direction indicated by the arrows. Now, by moving the slide along until the port *o*<sup>1</sup> is above the steam port *h*, then the port *m* will be closed, and *m* and *l* open to the eduction, so that the steam will act at the opposite side of the cylinder, and consequently the motion be reversed. It will here be observed that the lower cylinder ports *m* and *n* are never used for admitting steam, but only for leading off the used steam. The object in placing them so low in the cylinder is to allow the vacuum to act upon the pistons sooner. It must be kept in mind, therefore, that in whatever direction the shaft revolves, the steam is always admitted at one of the upper ports *k* or *l*, and the used steam let off at its opposite lower ports. All the ports where they lead into the cylinder are divided by bridges placed diagonally across them, so that the pistons may pass freely over them. From the relative position of the two cylinders, and the distance between their circumferences gradually increasing from contact at the upper point *h*<sup>1</sup> to the greatest distance at the lower point *h*<sup>2</sup> (which in this case is  $\frac{1}{2}$  of the diameter of the external cylinder, but may be varied according to circumstances), it follows that in whatever direction the engine revolves, the area of that part of the pistons which is acted on by steam and vacuum gradually increases, so that the principle of expansion is carried out to its full extent without the aid of expansion valves and gear. The steam passing through the eduction passage *g* is conducted by the eduction pipe *r* to the condenser *s*; *t* is the injection slide placed at the lower end of the eduction pipe, and conducting the water up the pipe, so as to act fully on the steam in passing downwards; it is worked by a lever and rod, connected to the handle *u*, which is placed in proximity with the other starting handles *h* and *p*. The air-pump is a double-acting one. It has a metallic packed piston, which is worked from the main shaft by a crank and connecting rod; and the piston-rod is kept parallel by two slide guides bolted on the air-pump cover. The pumps are worked from the main shaft by an eccentric, connected by a rod and lever to a rocking shaft *d*, on which are keyed two levers, which are connected by rods to the bilge and feed-pumps. The latter has its valve chest *j* bolted on the hot well.

*Condensation.*—The means adopted for the condensation of the steam is almost universally by the injection of cold water into the condenser, as in land engines. But for the purposes of steam navigation, this method is attended by several serious evils, which we shall briefly notice. In the first place, the water being generally strongly impregnated with earthy or saline matter, and

the steam consisting of pure water only, this extraneous matter continues to accumulate in the boilers, and at length to form incrustations, which if not removed, would eventually fill the boiler. To prevent this occurring, several methods are resorted to (some of which we shall notice), but none are completely successful, and all are attended with some objection. Another evil attendant upon this system of condensation when applied to marine engines, is that, as the supply of water to the boilers cannot be regulated by self-adjusting means, as in land engines, but must depend upon the care of the attendants, the fire-box and flues are liable to be burnt through in the event of the smallest inattention. Great care also is required in regulating the injection flow of water, for the vacuum causes the water to enter the condenser as fast, when the engines are moving slowly, as when going at a great speed; and as it is exceedingly difficult to regulate the injection exactly to the irregularities in the speed of the engine, there is the risk of diminishing the power of the engines by admitting too small a quantity of water, or of choking the condenser and air-pump by an excess, which is frequently the occasion of serious accidents. The plan most commonly resorted to for preventing the deposition of earthy matter in the boiler, is to discharge a portion of the water from time to time (technically called "blowing out"), replacing it with water from the hot-well, with the view to prevent the water becoming saturated. Mr. Seaward has contrived an ingenious and extremely simple plan to guide the men in the performance of this operation. In the glass gauges, attached to the boiler to show the height of the water, are two glass bulbs of different specific gravities: when the water in the boiler approaches within a certain distance of the point of saturation, the heaviest bulb rises to the surface, whereupon the engineer should blow out water from the boiler, replacing it with water from the hot well, until the lightest bulb sinks. This contrivance is doubtless of great

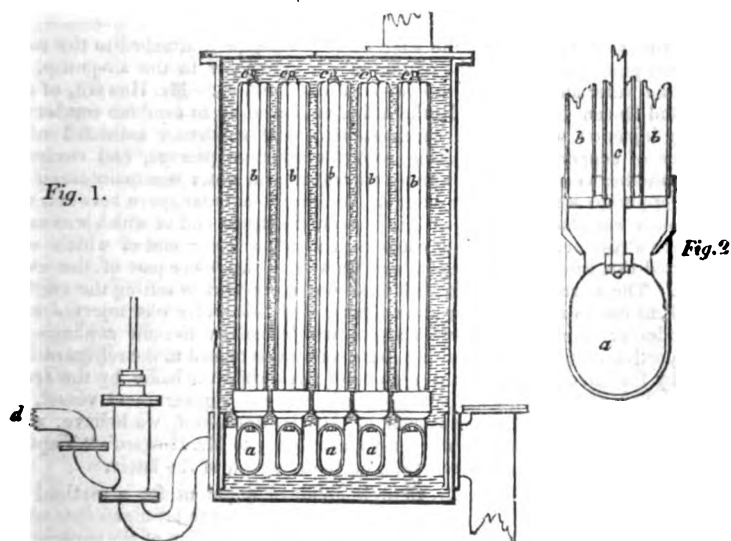


utility, as it enables the engineer to conduct the "blowing out" process with much greater precision than he could otherwise do. Mr. Seaward's apparatus for this purpose is shown in the annexed cut. At *a* is the glass gauge, chiefly inclosed in its metallic case *b*, and connected by the pipes and cocks *c* with the boiler *d*. At *e* and *f* are screwed plugs having vertical stems proceeding from them, which enter the ends of the glass tube; *g* and *h* represent the two glass balls, the lower one of which, being the heaviest, is shown as resting upon the top of the lower stem, while the upper one floats on the liquid. The process is, however, still dependent upon the attention of the engineer, and, therefore, liable to be neglected. To obviate this Messrs. Maudalay and Field, instead of periodically blowing out the water, maintain a constant stream of water through the boilers, by means of a small pump, worked by the engines, and so proportioned as to draw from the lowest part of the boiler, at each stroke, as much salt as is deposited in the boiler by the steam consumed in that stroke. But the operation of blowing off, in whatever way it is effected, is seldom completely effectual. It also causes a great waste of fuel by expelling from the boilers such a large quantity of water at the boiling point.

These and some minor objections to the system of condensing by injection, becoming more sensibly felt as steam navigation advanced, have caused numerous attempts to condense the steam without injection, by bringing it in contact with metallic surfaces, surrounded by cold water; and the system has at length been brought to such perfection, as scarcely to admit of further improvement. Some of the arrangements for this purpose, which have been put in practice, we shall now proceed to notice.

In 1822 Mr. M. I. Brunel obtained a patent for various improvements in marine engines; one of which improvements consisted in a method of condensing

the steam without injection; with the view of keeping the water in the boiler constantly fresh, and thus preventing the corrosion and incrustation which the use of sea water occasions. The condenser consisted of a peculiar combination of pipes as represented by *Fig. 1*, which is a vertical section of the apparatus. *a a a* are a horizontal row of pipes, which the inventor calls "mains;" each of these mains has on the upper side a row of sockets, and from each socket rises a cluster of copper pipes *b b*, of small diameter. These pipes are closed at the upper ends, but open at the lower, which are inserted in holes in a sort of cups, fitted to the sockets on the mains, and secured thereto by a long screw-bolt *c*; which passes down the centre pipe of each cluster, and is screwed into the main, as shown in *Fig. 2*, which is a section of one of the clusters on a larger scale. The mains and small pipes are placed in a cistern, through which

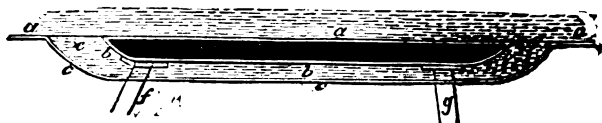


a current of cold water is maintained by a pump or other suitable means. The steam from the engines enters the mains *a* by the pipe *d*, and ascending through the small pipes *b b*, is condensed and restored to the form of water, which falling to the bottom of the mains, is withdrawn by a small force pump *e*, and returned to the boiler. We are not aware that this apparatus has been tried, but we think, that from the want of an air-pump, and from there being no thorough draft through the small pipes, it would be difficult to discharge the air from them; which would, therefore, prevent a good vacuum being obtained, and materially obstruct the condensation of the steam.

Amongst the first to put in practice this system of condensation in steam vessels was Mr. D. Napier, of Glasgow, who made trial of various arrangements of cooling surfaces, and if he did not completely succeed in removing the evils complained of, he at least greatly reduced the amount of them. The arrangement which he adopted in a small iron vessel, called the *Kilmun*, deserves notice from its extreme simplicity. The condensers consisted of a shallow iron casing, on each side of the engine-room, built upon the internal surface of the vessel, which thus constituted the outer side of the condenser. The inner side was covered by an iron casing, which communicated with the water outside by two large apertures in the vessel; one at the fore part of the condenser, and the other at the after part. The space between the condenser and the casing being sufficient to allow a free circulation of the water, the condenser was exposed on each side to a current of



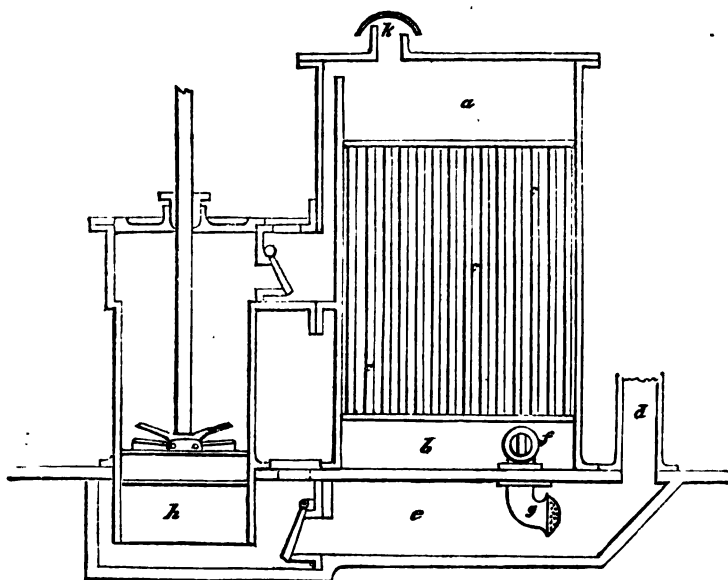
cold water whenever the vessel was in motion. The annexed diagram, representing a horizontal section of the condenser, will more fully explain the construction of this ingenious apparatus. *a a* represents a portion of the side of the vessel, constituting the outer side of the condenser; *b* the inner side; *c* a sheet iron casing, which encloses the condenser on the inner side; *d* the aperture by which the water is admitted between the condenser and casing; *e* the outlet aperture. The dark space represents the interior of the condenser, to which



the steam is conveyed from the slide case by the pipe *f*, attached to the top; and *g* is a pipe leading from the bottom of the condenser to the air-pump, by which the water and uncondensed vapour are withdrawn. Mr. Howard, of the King and Queen Iron-works, Rotherhithe, endeavoured to combine condensation by injection with surface condensation. The condenser consisted of a cylinder of copper, communicating with the eduction passage, and enclosed within another vessel, through which a current of cold water was maintained by means of pumps worked by the engine. Within the annular space between the two vessels was placed a worm of thin copper, the upper end of which was connected to a rose head within the condenser, and the lower end of which was connected to a small force-pump, which drew from the lower part of the condenser. The worm being filled with fresh water previous to setting the engine to work, at each stroke of the engine a portion of this water was injected into the condenser amidst the eduction steam, which thereby became condensed; and a portion of the water resulting therefrom was returned to the refrigerating worm by the force-pump, and the remainder forced into the boiler by the feed-pump. This plan of condensation was tried on board a government vessel, as also in two other vessels constructed by Mr. Howard, and, we believe, with satisfactory results: but as it formed only an accessory to Mr. Howard's "Vapour Engine," which proved a failure, it shared the rejection of the latter.

Some years subsequently, Dr. Church obtained a patent for a method of condensation, which was the same in principle, although the arrangements were somewhat different. The opposite figure represents a section of the apparatus. *a b c* is a vessel called the refrigerator. It is divided into three compartments, placed over the condenser *e*, the upper one *a* being connected with the lower one *b* by a series of pipes of small diameter, which occupy the middle portion or cold water cistern *c*. During the operation of the engine a constant stream of cold water is maintained through this cistern. The chambers *a* and *b* being previously filled with distilled water, upon the admission of the steam from the engines into the condenser *e* by the pipe *d*, the injection-cock *f* is opened, and the injection water is distributed in a shower amidst the steam by the rose *g*, by which the steam is instantly condensed, and the water resulting from the condensation, together with the injection water, is drawn off by the air-pump, and delivered into the compartment *a*, to be cooled down again by descending through the refrigerating pipes *c*. On the top of the chamber *a* is a small open pipe for the escape of any air given out by the water.

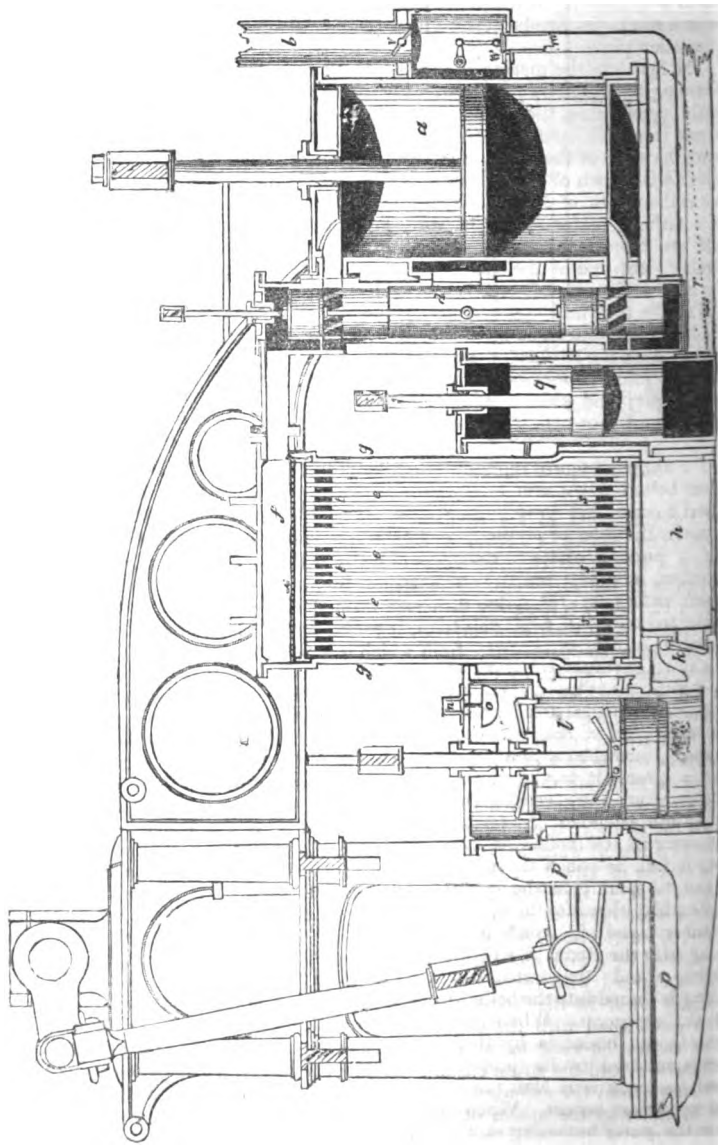
But no person has contributed so much to the introduction of this system of condensation as Mr. S. Hall of Basford, by his various contrivances to meet all the exigencies of the case, by his improvements in the construction of the apparatus, and by his unwearied exertions to demonstrate the superiority of the system, and to procure its general adoption. The following description will serve to give a general idea of his arrangements. The condenser consists of a cast-iron vessel, divided into three compartments by two horizontal plates. Into these plates are secured the ends of a vast number of copper tubes of small diameter, which form a communication between the upper and lower chambers,



or compartments, of the condenser. Through the middle compartment, or cold water cistern, a stream of cold water is maintained by a double-acting pump. The upper chamber communicates with the eduction passage, and the lower with the air-pump. The steam from the eduction pipe entering the upper chamber, is instantly dispersed through the condensing tubes; and by its contact with their cold surfaces, is reduced into water, and falls in a shower to the lower compartment; from which it is drawn, together with the air and uncondensed vapour, by the air-pump. The air-pump delivers the water into a hot well, which is closed at top, so that the upper part constitutes an air vessel, and the elasticity of the compressed air forces the water into the boiler, through a pipe proceeding from the lower part of the hot well to the feed valves or cocks on the face of the boiler. On the top of the hot well is placed a snift valve, to maintain the water in the hot well at a certain height, so as to prevent the air from entering the boiler along with the water. The whole of the steam from the cylinder is condensed, the water returned to the boiler; but there is always a loss of water to a greater or less extent by leakage of the boilers, and the escape of steam at the joints, and at the safety valve; the water in the boilers would, therefore, in time, be reduced below the proper level, unless means were taken to replace the quantity of water so lost. To meet this difficulty, a small vessel, called a "still," is inserted in the top of the boiler, and connected by a pipe and cock with the upper chamber of the condenser. This still is charged with sea water, and when it is perceived that the water has become lower in the boiler, the cock is opened; and a communication being thus established with the condenser, a partial vacuum is formed in the still. This causes the water to boil rapidly at a much lower temperature than it would otherwise; and the steam rushing into the condenser, is condensed along with the steam from the cylinder. The additional water thus obtained is delivered to the boiler by the action of the air-pump.

The annexed engraving represents, with some slight alterations, the arrangement adopted in a pair of engines constructed by Messrs. Hall, of Dartford, for the *Wilberforce* steam packet. We select it as the most perfect which we have seen, and because all the parts are distinctly shown. At *a* is the steam cylinder; *b* the

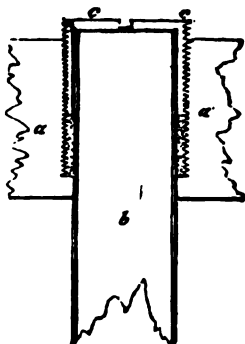
steam pipe; *c* a belt or channel surrounding the cylinder, and conveying the steam to the slide valve chest *d*; *f* is the upper chamber of the condenser; *g* the cold water cistern, in which the condensing tubes *e e* are situated; *h* the lower chamber of the condenser; *k* the foot valve; *l* the air pump; *m* the hot well, cast in one



with the air-pump; *n* the snift valve, attached to the float *o*; *p* the feed pipe, leading to the boiler; *q* is the cold water pump, placed between the slide case and the condenser; *r* the cold water supply pipe; the water is conveyed from the pump to the condenser by a channel cast on the foundation plate of the

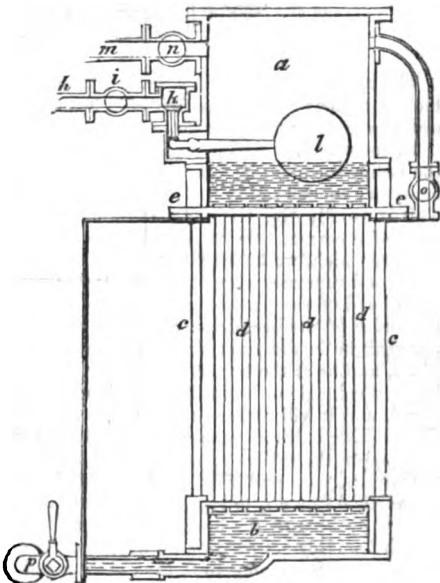
engine and enters the condenser by the apertures *ss*; *tt* are outlet passages by which it is discharged into the sea; *v* is the throttle valve, and *w* the blow-through valve; *x* in the upper chamber of the condenser, is the distributing plate; and *y* the pipe leading to the distilling vessel. The axis of the side levers is not carried through the condenser, as is usual; but each lever plays upon a stout pin, firmly keyed into a massive block, or pedestal, cast on the foundation plate.

The figure in the margin shows the mode of fastening the condensing tubes; *a* is a portion of the upper plate of the condenser, made of brass or cast iron, and having holes formed in it to receive the ends of the tubes, a portion of one of which *b* is shown of the full size. These holes are to the depth of about half an inch, made of a rather greater diameter than the tubes, and are tapped to receive a screwed ring or ferule *c*; the end of the tube being inserted in the hole, a ring of soft tape is slipped over the end of the tube and screwed firmly down into the hole in the plate, so as to press it into close contact with the surface of the tube; by which means a joint is formed perfectly steam and water-tight; and which yet allows for the expansion and contraction of the metal.



The annexed figure represents the distilling apparatus. At *a* is a cast-iron vessel bolted down over an aperture in the top of the boiler, and having a vessel *b* connected to it by rods *c c*. A series of brass or copper tubes *d d* connects the interior of the two vessels. The lower chamber, the tubes *d d*,

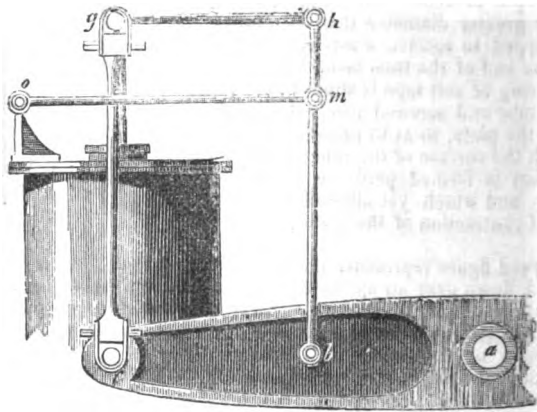
and a portion of the upper chamber, contain sea water, which enters by the pipe *h*, connected with the cold water chamber of the condenser; *k* is a valve governed by a float *l*, by which the water is maintained at the proper level. From the upper part of the vessel *a*, a pipe *m*, furnished with a stop-cock *n*, proceeds to the upper chamber of the condenser. When the attendant perceives the water in the boiler beginning to fall, he opens the cock *n*, and the steam from the water in the still rushes into the upper chamber, and is condensed along with the steam from the engines; and the water resulting is forced into the boilers by the air-pump. When the water in the boiler is by this means restored to its proper level, the cock *n* is shut, and the operation ceases. When, from the water becoming saturated, it is required to "blow out" the still, the cock *n*, and a cock *i*, on the pipe *h*, are shut; and steam is admitted from the boiler into the upper vessel, by opening the cock *o* and the cock *p*, which connects the lower part of the still with a discharge-pipe



passing through the ship's side, and the water and sediment are driven out; after which, by reversing the position of all the cocks, the still is recharged with water from the cold water chamber of the condenser.

Mr. Hall's invention has been extensively adopted by the Admiralty, the East India Company, and various other companies; as well as private individuals. The *Sirius* of 320 horse-power, fitted with Mr. Hall's condenser, was the first steam vessel which crossed the Atlantic from this country.

*Parallel Motion.*—The parallel motion commonly employed in marine engines, working with side beams, is exactly similar in principle to that employed in land engines; but owing to the parts being inverted, it appears different. It is represented in the annexed cut.

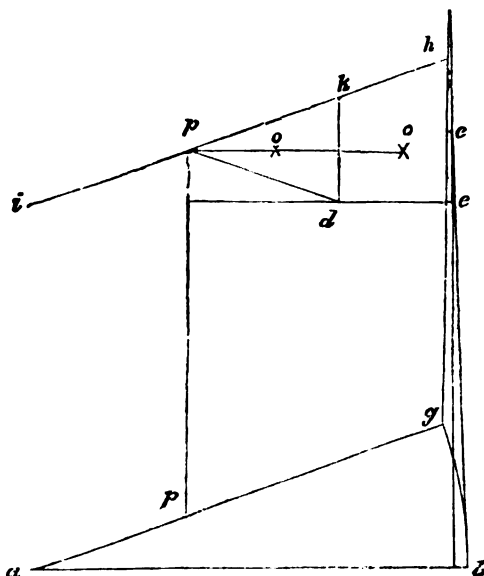


The radius shaft is usually worked by a single link, or side rod, which is attached to that radius bar and side beam which is next the vessel's side, in order to leave more space between the two engines for working the hand gear.

In constructing marine engines, it is occasionally required, that the centre of the radius rod shall be placed in some particular point; and it then becomes necessary to determine the length of the radius bar and of the parallel bar. This is usually ascertained by repeated trials with rods of different lengths, for want of a correct rule for readily determining it: we therefore give the following, which, we believe, has not before been published.

Let  $a b$  represent the beam at its horizontal position,  $c$  the centre of the cross head of the piston-rod, and  $c b$  the side rod by which it is connected to the end  $b$  of the beam  $a b$ ; and let it be required that the centre of the radius bar shall be in the point  $d$ ; then as the parallel bar is always parallel to the beam, and as at the horizontal position of the beam the parallel bar and radius bar will coincide or lie in the same horizontal plane, draw the line  $d e$  parallel to  $a b$ , and it will represent the position of the parallel bar and radius bar at this position of the beam; and  $e$  will be the point at which the parallel bar is attached to the side rod; and  $e d$  will be the difference between the length of the parallel bar, and that of the radius bar. Then through the point  $c$  draw the vertical line  $c f$ , to represent the path of the piston-rod, and draw  $a g$  in the highest position of the beam, making  $a g$  equal to  $a b$ ; then from  $g$  with the length  $b c$  intersect the line  $c f$  in  $f$ , and draw the line  $f g$ , upon which lay off the distance  $b e$  from  $g$  to  $h$ , then draw  $h i$  of an indefinite length and parallel to  $a g$ , and on it lay off  $h k$  equal to  $d e$ , the difference between the length of the radius bar and parallel bar; then, as the remaining portion of the parallel bar will be equal to the radius bar, and the two bars are connected at their extremity; if we draw the line  $k d$ , they will form with it an isosceles triangle,

the apex of which will be at the point of junction of the two bars ; therefore, to find the apex, upon  $k$  and  $d$  as centres, with any distance in the compasses describe arcs cutting in  $o$ , through which points draw  $op$ , cutting  $hi$  in  $p$ ;



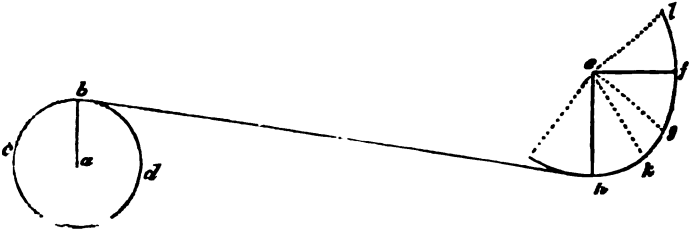
then draw  $dp$  and it will be the length of the radius bar ; and  $hp$  will be the length of the parallel bar. Then upon  $g$  a set off  $gr = hp$  and draw  $pr$ , and it will represent the back link, and  $r$  the point at which it is attached to the beam.

**Reversing Motion.**—In steam vessels it frequently becomes necessary to reverse the engines suddenly, and sometimes to run a considerable distance by the reversed motion. It therefore becomes indispensable that the engine should be so arranged as to be completely self-acting whilst running in either direction.

In the case of engines fitted with valves worked by a plug-rod and tappets, it is only necessary to reverse the position of the valves by hand, and when the crank has returned past the line of centres, the plug-rod will continue to work the valves, as before.

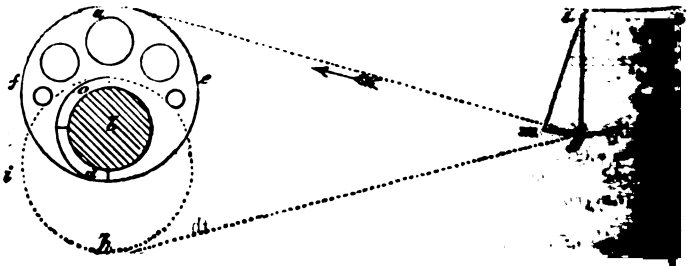
But this plan of working the valves is chiefly confined to pumping engines. In marine engines the valves are almost universally moved by a cam or eccentric, fixed upon the shaft ; whereby the motion is rendered much smoother, and freer from concussion ; but as the motion of the eccentric is reversed with the reverse motion of the shaft, the reversed action of the eccentric would cause the valve to move in the wrong direction unless some provision were made to the contrary, as will be more clearly seen in the following diagram. The eccentric may be considered as a crank whose length is equal to the eccentricity of the eccentric disk ; let  $ab$  represent the position of the eccentric, when the piston is commencing its ascending stroke, at which time we will suppose that the valve lever  $ef$  should be depressed, or move in the direction  $fg$  ; if the eccentric be carried round by the shaft in the direction  $bc$ , the eccentric rod  $bh$ , acting upon the lever  $eh$ , will depress the lever  $ef$

as required. But if the motion of the shaft be reversed, the eccentric, moving in the direction  $b\ a$ , will thrust the lever  $e\ h$  towards  $k$  and raise the lever  $e\ g$  to the position  $f\ l$ . Some arrangement it will therefore be seen is necessary, to cause the eccentric always to move the valves in the same direction, at any



given position of the piston; whether the shaft be revolving forwards or backwards.

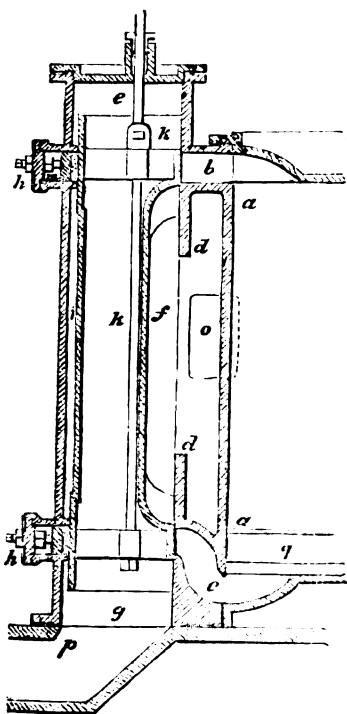
One of the methods employed for effecting this, is to fix two eccentrics upon the shaft, one adapted to the forward and the other to the backward motion of the shaft, each of which can be thrown into gear whilst the other is thrown out by the action of a lever. This method has the advantage of admitting the eccentric to be firmly keyed or staked to the shaft; it is however more expensive, and has the appearance of greater complexity, than the following method: which is therefore more generally practised. The eccentric  $a$  is not keyed to the shaft  $b$ , but is hung loose upon it with liberty of motion. On the side of the eccentric is cast a quadrantal piece  $c$ , and a similar piece  $d$  is fixed on the shaft, forming a species of clutch, the eccentric being carried round by the piece  $d$  pressing on the piece  $c$ . Now supposing the shaft to be revolving in the direction  $a\ e$ , and it be required to reverse the motion; the eccentric rod is thrown out of gear, and the position of the valves reversed by hand; this causes the shaft to revolve in the direction of  $a\ f$ , and the piece  $d$  receding from



the piece  $c$ , the eccentric remains stationary until the shaft has made half a revolution, when the position of the eccentric is directly opposite to what it would have been had it travelled round with the shaft, and it will now be urged round in the direction  $a\ f$  by the piece  $d$  acting upon the other end of the piece  $c$ , and the eccentric rod being thrown into gear, will be pulled in the direction  $g\ a$ . If the motion of the shaft had not been reversed, the eccentric would have been in the position  $b\ h$ , revolving in the direction of the  $h\ e$ , and the eccentric rod  $g\ h$  would be pulled in the direction  $g\ h$ ; the action therefore of the eccentric rod in both cases is to move the valve lever  $g\ l$  in the direction  $g\ m$ , and to depress the valve by the lever  $l\ n$ .

Another plan which is sometimes adopted, is, instead of reversing the position of the eccentric upon the shaft, to fix a double ended lever upon the valve shaft, and to connect the eccentric rod with the upper or lower end of the lever, according to the direction in which the paddle shaft is to revolve.

The "long slide," invented by Mr. Murdoch, of the firm of Boulton and Watt, is generally employed in marine engines. The annexed figure is a



section of one of these slides. At *a a* is a portion of the steam cylinder; *b* the upper steam passage; *c* the lower steam passage; *d* a steam channel, cast upon the cylinder, between the necks *b* and *c*, to which is attached, by a flange, the slide case *efg*, which is divided into three parts by the packing boxes *h h*, the middle part *ff* communicating with the steam channel *d*; and the upper part *e*, and the lower part *g*, communicating with each other by means of the hollow slide *k*: this slide is in its horizontal section of a semi-cylindrical figure; the flat part of the slide, and the face of the steam passage, are planed, and ground upon each other, so as to be steam-tight when in contact; and the slide is pressed against the face of the steam passage by semicircular blocks *m n*, which are faced with a broad soft gasket, and are pressed forward by screws at the back of them; *o* is the opening to which the steam pipe is attached, and *p* a channel, cast in the bed plate, and connecting the lower division *g* of the steam-chest, with the condenser; *q* a portion of the piston. In the sketch the piston is shown at the bottom of the cylinder, as having completed the downward stroke; and both the steam passages are closed by the slide *k*. That part of the cylinder

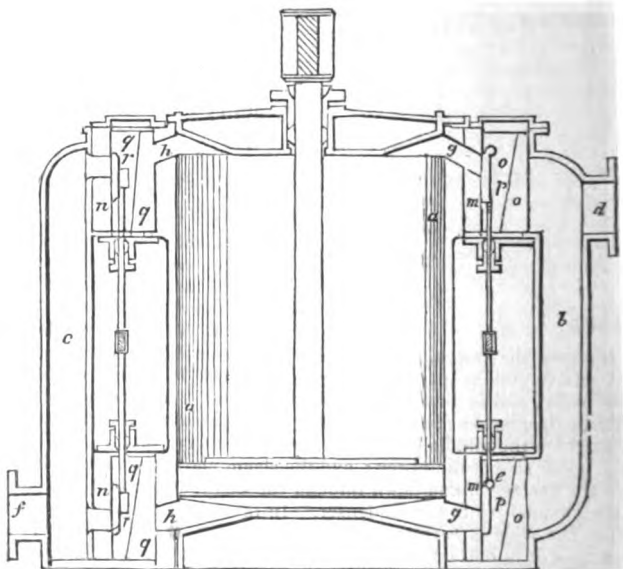
which is above the piston, is filled with the steam which has depressed the piston; and the middle part *ff* of the steam-chest is in free communication with the boiler, and is, therefore, filled with steam. In this state of things, if the slide be depressed a distance equal to the depth of the steam passage *b* or *c*, the steam from the middle part of the steam-chest will rush through the passage *c*, to the under side of the piston; and the steam above the piston will pass out through the passage *b*, and down through the central part of the slide *k*, and along the channel *p* into the condenser. In this species of slide valve it will be seen, that the slide is surrounded by steam, which, therefore, exerts no more pressure upon it in one direction than another; and the only friction is that caused by the packing at the back of the slide. The steam passages also are much shorter than with the D slide, so that there is much less loss of steam than in the latter. The slide is usually either faced with gun-metal, or wholly composed of it; and for engines of large dimensions, instead of one long slide, with a central tube, there are two short slides, which are connected together by stiff rods; and the upper and lower divisions or vacuum spaces of the slide case are connected by side pipes instead of the central tube.

Slide valves, although very generally used in marine engines, are, however, liable to serious objections, from the necessity of using hemp packing at the back of the slide to keep it on the face. This packing requires to be frequently and carefully adjusted; and should it be neglected, or ineffectually performed, there will be a great loss in the active power of the engine. The packed slide is, however, but seldom perfectly steam-tight, because if the packing be screwed down so close as to prevent the escape of steam past it, the friction becomes excessive: it therefore becomes necessary, for the easy



working of the valve, to admit of this escape, and consequent loss of power, rather than contend with the very great friction which results when the valve is packed quite tight. Again, the quantity of hemp for packing, as well as of tallow required to lubricate the same, is very great; and the slides are subject to considerable wear and tear, owing to the force with which they are pressed against the faces.

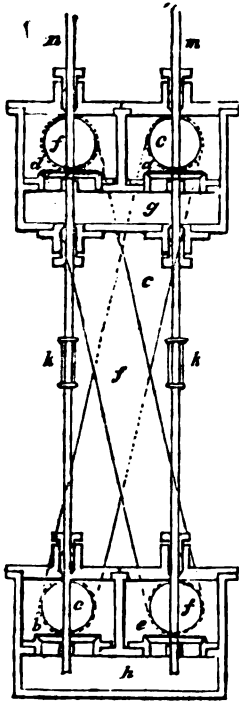
*Seaward's Slide Valves.*—The annexed engraving represents these valves as applied to a marine engine. *aa* is the steam cylinder, and *b* and *c* are two nozzles, either cast upon the cylinder, or firmly bolted to it; *b* is the steam nozzle, connected to the steam pipe by the neck *d*; and *c* is the eduction nozzle, communicating with the condenser by the neck or opening *f*; *gg* are the steam passages into the cylinder, and *hh* the eduction passages. In each nozzle are chambers to receive the cast-iron blocks *mm* and *nn*, which are ground to a perfectly plane surface on the face. The blocks *mm* have apertures, coinciding with the steam passages *gg* in the cylinder, and are firmly keyed against the cylinder by the keys *oo*; *pp* are the steam valves, which are flat plates of cast-iron; they are attached to the valve rods by a hinge joint, the object of which is to allow the valve to swing off the face of the valve seats or blocks *mm*, to allow any water to escape which may find its way into the



cylinder. The rods by which the valves are moved are connected, so as to cause the valves to move together. The blocks *nn* have apertures corresponding to the passages in the eduction nozzle, against which they are firmly keyed by the keys *qq*. The eduction valves *rr* are flat plates of cast-iron, similar to the steam valves: but as they are never required to leave the valve seat, they are fastened to the valve rod without a hinge-joint. Upon examination of the above arrangement, it will be seen that the steam valves are pressed to their seats by the steam in the steam nozzle, and the eduction valves are pressed against their seats by the steam in the cylinder. The lever by which the steam valves are moved is connected by a rod to that which works the eduction valves, so that the one set counterbalances the other.

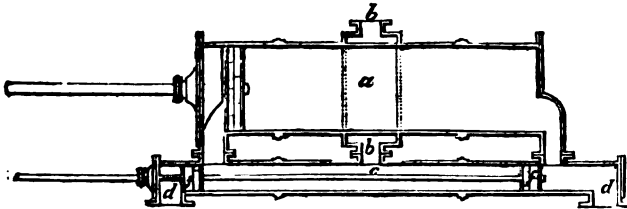
*Morgan's Conical Valves.*—Mr. W. Morgan obtained a patent for an "improved Construction of Conical Valves," which remedies the objection of the

great pressure to which they are subject, when large, in a very simple and ingenious manner. The eduction valves are so placed, that the steam in the cylinder acts upon their under surfaces, whilst the steam from the boiler presses upon the upper surfaces of the steam valves; and the upper steam valve being connected with the lower eduction valve, and the lower steam valve with the upper eduction valve, the pressure upon the under surfaces of the eduction valves nearly neutralizes the pressure upon the upper surface of the steam valves; the pressure being merely equal to the difference between the areas of the two surfaces; so that it requires but little force to move the largest valves.



The annexed sketch will help to convey an idea of these valves. *a* is the upper steam valve; *b* the lower steam valve, and *c* the steam pipe; *d* is the upper eduction valve, and *e* the eduction pipe. The lower compartment *g* of the upper valve box communicates with the upper steam passage of the cylinder; and the lower compartment *h* of the lower valve box communicates with the lower steam passage of the cylinder; the tail or spindle of the steam valve *a* passes through a stuffing box in the lower compartments of the upper valve box, and is connected by a coupling nut *k* with the spindle of the eduction valve *e*. The tail of the eduction valve *d*, in like manner, passes through the stuffing-box in the lower compartment of the upper valve box, and is connected by the coupling nut *l* with the lower steam valve *b*. The lifting rods *m* and *n* pass through stuffing-boxes in the covers of the valve boxes, and are wrought by means of two revolving cams, on a way shaft. By this arrangement the motion of each steam valve and its corresponding eduction valve is rendered simultaneous; and the pressure downwards upon the surface of the steam valves, is nearly counterbalanced by the upward pressure upon the eduction valves: a slight preponderance being given to the former, in order to keep the latter firmly to their seats when closed.

*Piston Slide Valves.*—Instead of the common semi-cylindrical slide valve, cylindrical, or piston slides are sometimes made use of, and possess this advantage over the former, that the packing being metallic, requires no attention, and that the friction is much less. The annexed cut shows a valve of this description. *a* is the cylinder, with *c* the slide case; *d d* eduction passages; *ff* the slide pistons, which are fitted with metallic packings. That portion of each end of the slide



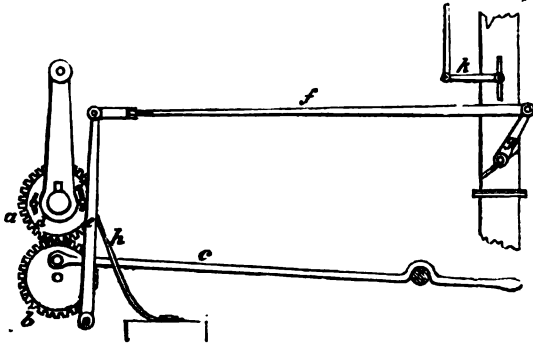
case in which these pistons work, is bored out very truly; and in order to allow the segments of the packings to pass over the passages into the steam cylinder, bridges are cast in the passages, which prevent the segments from flying out of their places.

*Expansion Valves.*—Within these few years the application of the expansive action of steam has been gradually coming into use in marine engines, and with considerable advantage; but many circumstances tend to oppose its general adoption in this class of engines, and to prevent the realization of its advantages to their full extent. Foremost amongst these obstacles is the dread which is generally entertained of the use of high-pressure steam, on account of the supposed greater danger; and so long as the general opinion on this subject remains unchanged, steam-boat proprietors will fear to employ high-pressure steam, however much they may be convinced of its superior mechanical advantage. By cutting off the steam at a quarter of the stroke, the effect is nearly doubled, but to do this requires that the pressure of the steam should be nearly four times greater than for a non-expansive engine. Larger cylinders are likewise requisite, whilst in steam vessels it is an object to reduce the bulk and weight of the machinery as far as possible. The comparatively short length of stroke in marine engines is another obstacle, as scarcely allowing sufficient time for the admission of the steam; nor is the construction of the ordinary slide valve very well adapted to working expansively. In the Cornish engines, which are mostly pumping engines, and single acting, the valves are of the conical kind, and are each moved separately by an exceedingly ingenious apparatus, but which is not at all adapted to the use of steam vessels. In marine engines the kind of valve which is generally employed, is, as already stated, the long slide valve; the slide is moved by an eccentric, with an alternately accelerated and retarded motion, but is never absolutely at rest. Some arrangement therefore is necessary to close the steam passage, and still keep the eduction passage open. The most common plan for effecting this is, to make the blank part of the slide, or that which covers the passages, longer than the passages themselves, and to give the slide a proportionably longer stroke; but the motion of the eccentric shuts off the steam too slowly, and the two passages cannot be opened exactly at the same time, at the reversal of the stroke, so that either the eduction passage is opened too soon, or the steam passage too late. Cams of various shapes have been substituted for the eccentric, with the view of opening and closing the passage more rapidly, and of allowing the slide to be at rest at certain points of the stroke; but they seldom work smoothly, and are generally soon destroyed by the violent concussion they experience in bringing the slide so quickly into motion from a state of rest. Some of these cams have also the defect of not being adapted to the reverse motion of the engines.

Another plan which is sometimes adopted is to construct the slide as for non-expansive engines, and to attach a separate valve between the steam pipe and the slide case. This valve is of a construction to move with little friction, and consequently requires but little force to put it in motion. It is worked by a separate cam on the paddle shaft, which can be so arranged as to close the valve at any part of the stroke, within certain limits. Although rather more complex, this plan is decidedly superior to the others, in the precision of its action, and in the circumstances that the expansion can be varied, or the engine made to work at full pressure at pleasure.

*Snodgrass's Expansion Apparatus.*—The annexed cut represents Mr. Snodgrass's method of working expansively, with the ordinary slide valve. Upon the paddle shaft, and at the back of the crank, is fixed a spur wheel *a*, which gives motion to another wheel *b*, of similar dimensions; and which revolves upon a stout pivot or stud. This latter wheel corresponds to the ordinary eccentric, and has on its face a pin, to which is connected the eccentric rod *c*, which moves the valve shaft. On the face of the wheel *a* are two pins, which carry the antifricition rollers *d d*, that act alternately against the perpendicular lever *e*, to the top of which is jointed a rod *f*, that is connected to the governor valve *g*, placed in the pipe which conveys the steam to the slide case; *h* is a spring acting on the back of the lever, to force the lever forwards as the rollers *d* on the wheel *a* retire; and thus by the alternate action of the spring, and of the rollers *d d*, the governor valve is opened and

closed twice during each revolution of the crank. The rod *f* may be elongated or contracted at pleasure, by turning the nut, attached to the fork which



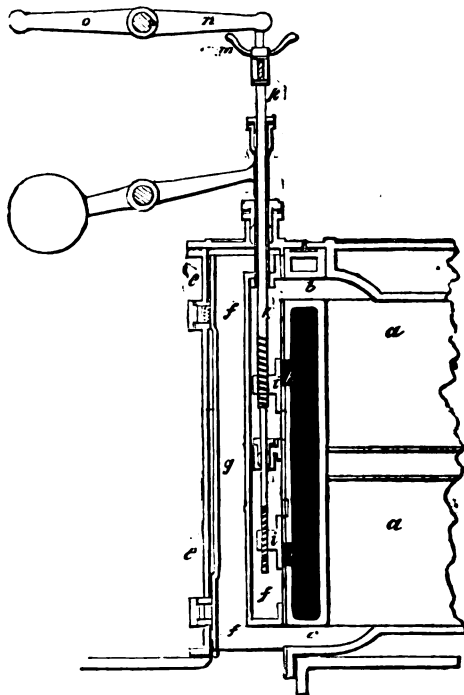
connects it to the lever *e*, and by this means the steam may be cut off at any portion of the stroke, and the remainder of the stroke be performed by its expansion; *k* is a throttle valve to be regulated by hand; it is connected by a rod to a lever under the command of the pilot.

When conical valves are employed in lieu of slide valves, and receive their motion from an eccentric on the paddle shaft, a separate valve, moved by a separate cam, is necessary to work the steam expansively. This additional valve and cam may, however, be dispensed with, if, instead of the rocking shaft, a revolving shaft is substituted, carrying a separate cam for each valve; which can thus be made to open and close at that period of the stroke which is required to produce the best effect. The revolving shaft is put in motion by the paddle shaft, by means of suitable gearing. By this mode of working the valves, the action is rendered as rapid as if raised by tappets, and the concussions of the latter mode are avoided.

*Bourne's Expansion Valves.*—This is an arrangement for cutting off the steam at any portion of the stroke, and for varying the quantity of steam admitted to the cylinder, without stopping the engine; for which in connexion with other improvements, Mr. Bourne of Dublin obtained a patent in 1838.

*a a* represents a section of a portion of the steam cylinder; *b* the upper, and *c* the lower steam passages; *d* the steam jacket or belt, *e e* the slide case connected at bottom with the condenser, and *f* a long D slide, by which the passages *b* and *c* are opened and closed in the usual way. That portion of the slide by which the steam is admitted to the passages, is divided into two parts by a partition *g*, which is faced and ground upon the face of the steam belt. The steam is admitted to the slide from the belt, by the apertures *h h*, to which are admitted the sliding valves *i i*; these valves are moved by a rod *k*, which passes through the rod of the D slide (made hollow for that purpose), and through a stuffing-box in the division *g* of the D slide. Upon this rod are cut two screws, one above and the other below the stuffing-box, which screws work in nuts on the back of the slides *i i*, and being one a right-handed, and the other a left-handed screw, upon turning the rod by means of the handle *m*, fixed on to its upper end, the valves are made to approach or recede from each other, according to the direction in which the rod is turned. The D slide is worked by the eccentric in the usual way, and opens and closes the two passages *b* and *c* at exactly the same time, but the rod *k* by which the slides *i i* are worked is connected to an arm *n* fixed on the shaft of the radius bar *o*, which governs the parallel motion of the engine, so that the D slide and the slides *i i* move independently of each other, and whilst the steam passages into the cylinder (*b* and *c*) remain open throughout the stroke, the steam passages into the slide (*h h*) can be closed at any portion of the stroke which may be decided

on. This is effected as follows: the depth of the apertures  $h h$  is equal the length of the stroke of the arm  $n$ , but the slides  $i i$  are so arranged upon the rod  $k$ , as to contract them in proportion to the degree of expansion at which the steam is to be worked; thus if it be required to cut off the steam at half stroke, allowing it to expand through the remaining half, the slides  $i i$  are so set upon the rod  $k$  that each aperture alternately shall be but half open at the commencement of the stroke, and as the slides begin to close with the commencement of the stroke, the passages,  $h h$ , will be closed when the slides have made half



the stroke, as in the figure, and no more steam will be admitted to the cylinder, and the remainder of the stroke will be performed by the expansion of the steam already admitted. If the steam is to be cut off at  $\frac{1}{4}$  of the stroke, the passages  $h h$  must open only  $\frac{1}{4}$ , and if it is desired to work at full pressure throughout the stroke, the slides must be so arranged that the passages shall be fully open at the commencement of the stroke.

*Boilers.*—It having been found desirable in steam vessels to economize to the utmost the space occupied by the apparatus, a material difference in the construction of the boilers becomes necessary from those used in land-engines, in order to the economical combustion of the fuel; and in consequence of the different arrangements, marine boilers are more complex, heavy, and costly, than land-boilers of similar power. In general, marine boilers are composed of an external shell or casing, with rectangular sides, stayed together by tie-bars; and within the shell are contained the fireplaces or furnaces, and the flues for the passage of the flame and smoke, the flues being deep rectangular channels, which, after making various turnings, unite in one common chimney or funnel; the furnace, ash-pit, and flues, being entirely surrounded by water. In order to maintain a considerable depth of water over the flues and furnaces,

and at the same time afford sufficient space for the accumulation of steam, an elevated compartment, called the "steam-chest," is formed for the purpose upon the top of the boiler, and the bulk of the boiler is occupied with water.

Fig. 1.

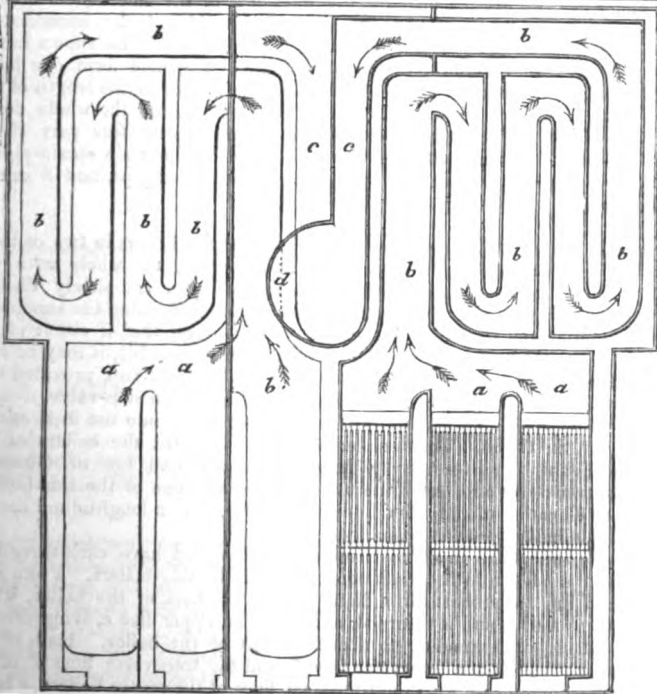
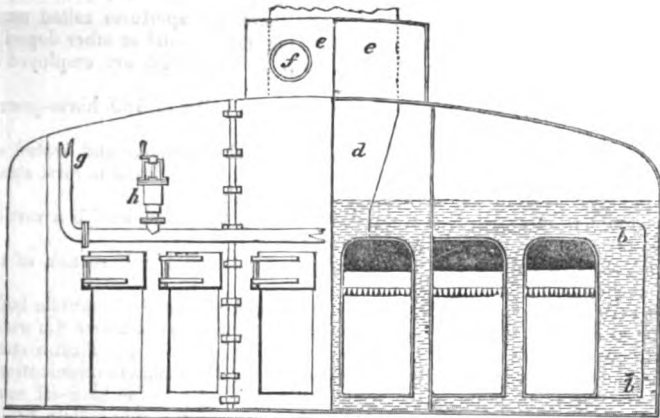


Fig. 2.

In boilers of large power, and especially in sea-going vessels, in order to prevent the water from accumulating on the lee side of the boiler, and leaving

the weathermost flues uncovered by water, the boiler is formed in two or three longitudinal compartments, with a free steam communication between each; or one or two divisions of plate-iron are formed within it, running from front to back, and extending from the bottom upwards, higher than the water line in the boiler. At the bottom of the boiler are pipes, passing through the vessel's sides, and furnished with stop-cocks, or valves, for "blowing off" the water from time to time, as it becomes saturated with salt; and there are apertures called mud-holes, closed by doors, for the purpose of raking out the mud or other deposit.

We proceed to give a few of the forms of boilers which are employed in steam vessels.

The engravings on the opposite page represent a boiler of 180 horse-power, constructed by Messrs. Fawcett of Liverpool.

From the very great extent of flue through which the smoke and heated air has to pass before it reaches the chimney, these boilers are found to raise steam very rapidly, and with a small consumption of fuel.

The one-half of *Fig. 1* is a front elevation, and the other half is a vertical section of the boiler through the fire-places.

*Fig. 2* shows a half plan of the flues, and a horizontal half section of the same above the fire-bars.

The boiler is composed of three separate parts, the sides of the middle boiler serving as a side to each of the side-boilers. At some distance above the water-line, large apertures are cut in the sides of the middle boiler, to form a steam communication between the three compartments, and a water communication is established below by a pipe from each boiler opening into the blow-off main. Each boiler has two fire-places, and the flues *a a* of the side-boilers branch into the flues *b b* of the contiguous fire-place of the middle boiler, immediately at the back of the bridge; and, after taking the circuitous course shown in the plan by the arrows, they unite at the back of the boiler, and form one large flue *c*, from which the chimney *d* rises at about the middle of the length of the boiler. The flues are not divided horizontally, but extend the whole depth from *b* to *b*, as shown in the vertical section. Towards the fore part of the middle boiler is a steam-chest *e*, from which proceeds the main steam-pipe *f*, which conveys the steam to the cylinders. *g* is the feed-pipe, and *h* one of the feed-valves.

*Separate Elliptical Boilers.*—Instead of building the boilers in two or three flat-sided divisions up to the water-line, and covering the whole with one slightly convex roof or top, many manufacturers prefer completely distinct boilers of an elliptical form, connected merely by pipes, forming the steam and water communications. This method has the advantage, that if either of the side-boilers should be by any accident rendered unserviceable, it may be shut off, and thus it would not impair the efficiency of the other two, provided that the steam communications should be each furnished with a stop-valve.

Elliptical boilers, variously arranged, are getting much into use in Scotland, especially on the Clyde. The annexed sketches represent the boilers of the *Sirius* steam-ship, constructed by Messrs. Wingate and Co. of Glasgow. *Fig. 1* is a transverse section of the middle boiler and one of the side-boilers, and a front elevation of the other side-boiler. *Fig. 2* is a longitudinal section of the middle boiler.

The three boilers are all of the same dimensions, and have each three fire-places *a a a*, as shown in the elevation of one of the side-boilers. From each fire-place a flue *b b* proceeds in a direct line to the back of the boiler, where it is curved upwards, and is returned, and forms an upper flue *c*, lying directly over the flue *b*, and extending to about midway of the boiler. Each of the three flues *c* opens into a transverse flue *d*, and the transverse flues *d* of the side-boilers communicate with the transverse flues of the centre boiler. *e* is the chimney, rising from the upper side of the transverse flue of the centre boiler, and passing through *g* the steam-chest of the same boiler; *h* and *k* are the steam-chests of the side boilers, and communicate with the steam-chest of the centre boiler, the former by the pipe *m*, and the latter by the pipe *n*. *A*

the bottom of each boiler is a pipe *o*, furnished with a cock, and branching into the transverse main *p*, by which means the communication between the water spaces of any two of the boilers can be opened or cut off at pleasure; *q* is the steam main proceeding to the engines; *r* the safety-valve, upon the

Fig. 1.

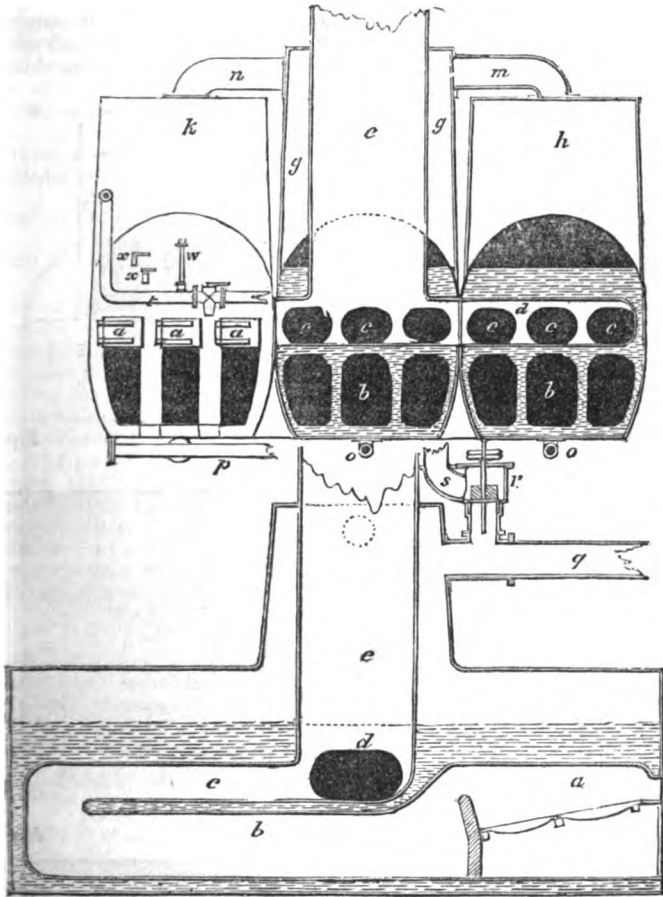


Fig. 2.

spindle of which are placed the weights; *s* the pipe for the escape of the steam which has passed the safety-valve; *t* is the feed-pipe, fitted with stop-cocks; and *w* a glass gauge for showing the height of the water in the boiler; *x* are gauge-cocks for the same purpose.

"United Kingdom" Boilers.—The annexed figures represent the boiler of the United Kingdom steam-packet, the engines of which are of 200 horse-power, and constructed by Mr. D. Napier, of Glasgow.

Fig. 1 is a front elevation; Fig. 2, a lateral elevation; and Fig. 3, a longitudinal section. The boiler, which is of wrought iron, is 25 feet 6 inches in length, 19 feet in breadth, and 8 feet 6 inches in height. There are eight



rectangular tubes *b b* running lengthways of the boiler. The fire is placed in the upper part of each of these, upon the bars *c c* in the section. At the

Fig. 1.

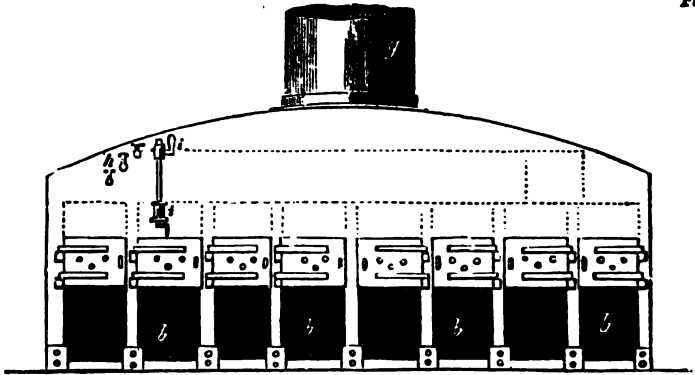


Fig. 2.

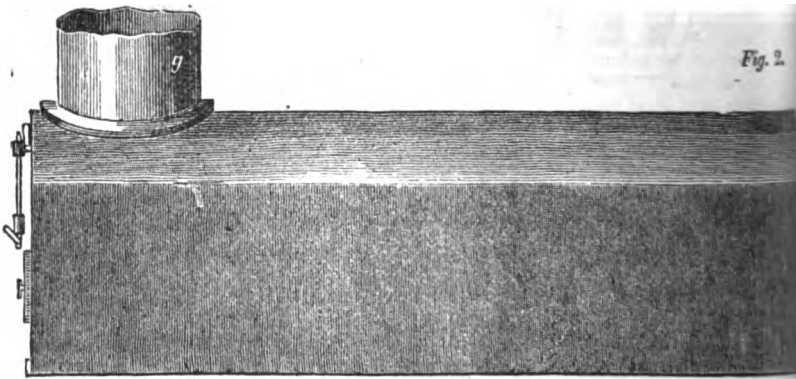
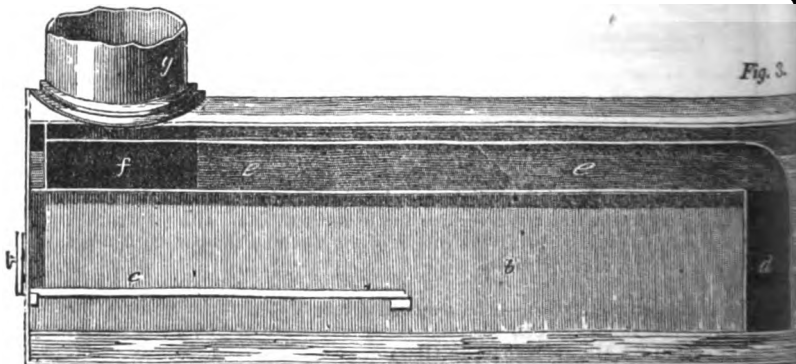


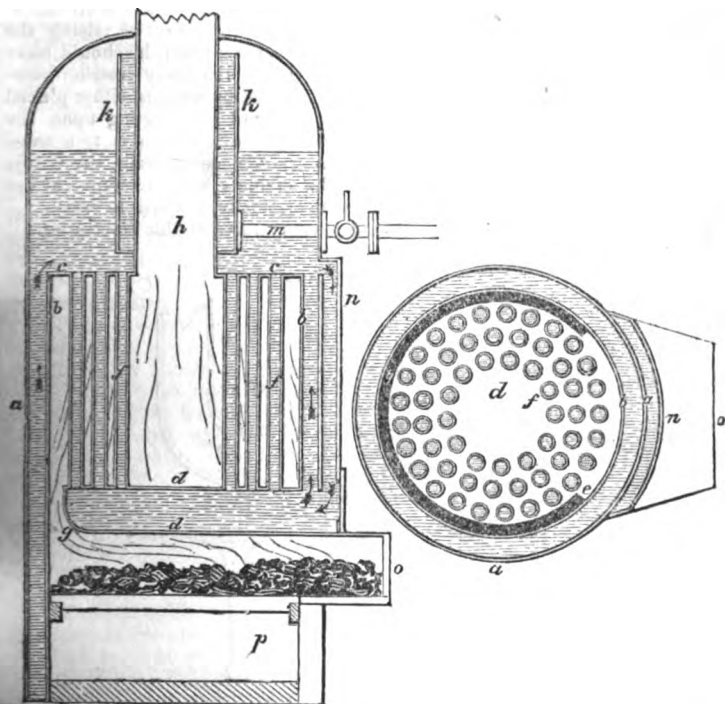
Fig. 3.



farther end of the tubes is a transverse one *d*, extending the whole breadth of the boiler, which communicates with every one of the tubes containing the fire

at each end of *d*. On the top, a return tube *e e* carries off the smoke and fire into another transverse tube *f*, out of the centre of which the chimney *g* rises. The cocks *h h h* are for ascertaining the height of water in the boiler. As an additional precaution, there are two cocks *i i*, which are placed, the one considerably above, and the other as much below, the assumed level of the water; these cocks communicate with a vertical glass tube *j*, of sufficient strength to endure the force of the steam. On the cocks *i i* being opened, water enters into the lower cock, and steam into the upper one; and the pressure being the same in the boiler, the water stands at the same level, and thereby indicates at all times whether it be too high or too low in the boiler.

Recently, steam of high pressure having come somewhat extensively into use, in order to carry out as far as possible the expansive system of action, a corresponding modification in the construction has become necessary, and tubular boilers, variously arranged, have been employed. The annexed figure

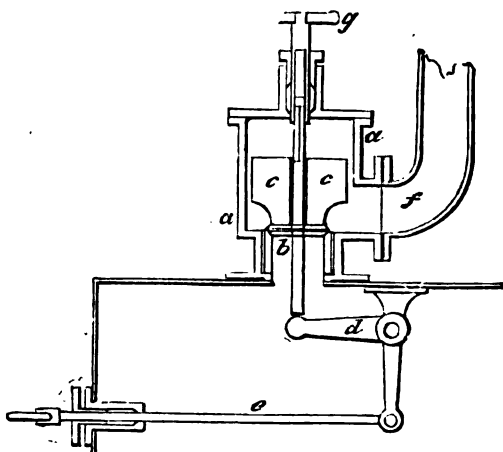


represents an arrangement for which Mr. D. Napier obtained a patent, and which he has introduced into several vessels under his management. The boiler is a cylindrical chamber, with a dome top, constituting the outer shell, or casing of the boiler; and *b b* is a smaller cylinder, with a flat top *c*, placed concentrically within the chamber *a*, and constituting the fire-box. The space included between the two cylinders forms the water-chamber. Within the fire-box, and on a level with the upper part of the fire-door, is a flat tubular vessel *d*, which is connected to the annular part of the water-chamber by a neck *e*, and to the upper part of the chamber by several concentric rows of pipes *ff*. The vessel *d* is somewhat less in diameter than the fire-box, so that there is an annular space *g* between its circumference and that of the fire-box, which forms a flue or passage through which the smoke and heated gases from the furnace pass, and thence traversing the interstices between the pipes *ff*, escape by the chimney *h*, which rises from the roof of the fire-box, and passes

out through the dome of the boiler. In order to protect the chimney as much as possible from the effects of the fire, that portion of it which is within the boiler is surrounded by a water casing *k*, which is open at top. The feed-water for continuing the supply of the boiler enters this casing near the bottom by the feed-pipe *m*, and overflows at the top; and in order to maintain a free circulation, a wide channel *n* is formed on the outside of the casing, which, being farther removed from the fire-box than any portion of the annular chamber, a descending current is maintained therein, whilst an ascending one takes place in the pipes and the annular water-chamber, as is indicated by the arrows. *o* is the fire-door, and *p* the ash-pit.

*Safety Valves.*—Various descriptions of safety valves are in use on board steam vessels, some of which are of a very improper construction, being liable to be impeded in their action by design or by accident. For a safety valve to fulfil the purpose for which it is designed, it should be so arranged that the load upon it cannot from any cause exceed that which the boilers have been calculated to sustain, and whilst the engineer should have the means of raising the valve, so as to ascertain from time to time that it is not set fast, he should have no means of holding it down, or preventing its rising. In many vessels, however, the valves are placed above deck, and are loaded by weights, either placed directly on the spindle, or suspended from a steelyard lever acting upon the spindle; in either case the load may be increased and too often is to a most dangerous extent. In others, a more judicious arrangement prevails, the valves being so situated as to be inaccessible to the engineer, who therefore cannot increase the load beyond that which they were originally intended to carry.

The annexed cut represents a section of a safety valve of this description.



*a* is the valve-box, *b* the valve, upon which is placed a cylindrical weight *c*, which nearly fills the box, there being merely sufficient space round at the circumference to prevent rubbing, and sufficient space between the top of the weight and the cover to allow the valve to rise to the requisite height, and the cover is bolted down to the box. *d* is a bell-crank lever within the boiler, acting upon the lower end of the valve spindle; *e* is a rod connected to the lower arm of the lever, and passing through a stuffing-box in the front of the boiler. Upon pulling out the rod *e*, the valve is raised by the lever, and the steam escapes at the waste pipe *f*, and upon thrusting the rod in, the valve falls by its weight. In order to guide the valve, and at the same time to afford the means of turning it in its seat, the upper end of the spindle, which passes through the weight *c*, is made square, and enters a corresponding cavity in the key *g*, which turns in a stuffing-box in the cover, the cavity being of sufficient depth to allow the valve to rise.

## SECTION IV.

## THE CONSTRUCTION AND ARRANGEMENT OF THE PROPELLING MACHINERY.

Analysis of the various Plans for Propelling.—The ordinary or undershot Water-wheel—defects of.—Galloway's Cycloidal Paddle-wheel.—Gemmell's Paddle-wheels.—Galloway's double oblique Wheels.—Buchanan's Parallel Float-wheels.—Oldham's vibrating Float-wheels.—Morgan's vibrating Float-wheel.—Dawson's radiating feathering Paddles.—Stead's Ditto.—Leeming's eccentric sliding Floats.—Endless chain-propellers.—Spurgin's endless Chain-propeller.—Stevens's crank-action Propellers.—Nairne's collapsing Propellers.—Perkins's oblique sculling Wheel.—Linnaker's Propelling Pumps.—Busk's Hydraulic Propellers.—Ericsson's screw Propeller.—Hunt's propelling and steering Screw.—Canal Navigation.—Seaward's Spike wheel.—Saxton's differential warping Wheels.

In the present section we shall consider the means by which the power of steam is applied to the propelling of vessels. Numerous plans have been brought forward for this purpose, but they are all reducible to a few classes; the difference between those in each class being merely modifications of some particular principle. We shall therefore limit ourselves to a description of one or two examples from each class. In most of the various plans adopted or proposed for propelling vessels by steam, the motion is produced by one or other of the following means.

1. Wheels on the principle of the undershot water wheel, with fixed floats variously arranged.—Illustrated by the examples herein given of *Galloway's* and *Gemmell's* wheels.
2. Wheels with moveable floats turning on horizontal axles or spindles.—Illustrated by the inventions of *Buchanan*, *Oldham*, and *Morgan*.
3. Wheels with moveable floats turning on radiating axles or spindles.—Examples of which are produced in the inventions of *Dawson*, *Oldham*, and *Stead*.
4. Wheels with floats sliding along the arms, towards, and from the centre of the wheel.—Sufficiently illustrated by the invention of *Leeming*.
5. Ranges of paddles attached to endless chains.—Shown in the invention of *Spurgin*.
6. Ranges of paddles attached to cranks.—Illustrated by *Stevens's* invention.
7. Paddles which collapse during the return stroke, so as to offer less resistance at that time, commonly known as the duck's-foot apparatus.—An example of which is given in *Nairne's* invention.
8. Sculling.—Exhibited in *Perkins's* invention.
9. A stream of water expelled from the vessel, either by pumps or by the direct action of the stream, on the principle of Savery's engine.—An example of which is afforded in the invention of *Linnaker*.
10. By the reaction of the water, on the principle of Barker's mill.—Exhibited in the invention of *Busk*.
11. A water screw.—Illustrated by the invention of *Ericsson*.

Besides the above plans, which are applicable to steam navigation in general, others have been proposed for the navigation of canals and shallow rivers, some of which we shall notice.

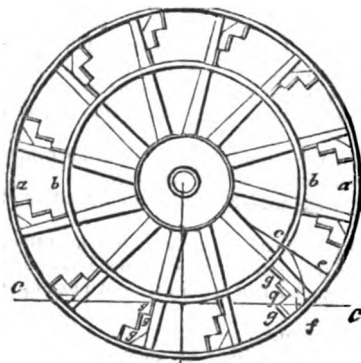
*Undershot Water Wheel*.—Of all the plans of propelling, the undershot water wheel, with radiating floats attached to the arms of the wheel, is that which is most generally employed, on account of its extreme simplicity, its strength of construction and its little liability to derangement. The proportions most generally adopted are to make the diameter of the wheel equal to four times

the length of the stroke, and the depth of each paddle about one-eighth of the diameter. In steamers intended to ply chiefly on rivers, the width of the paddles is commonly about one half the diameter of the whole, but in sea-going steamers the breadth is commonly about one-fifth less.

Although the undershot water wheel is generally deemed superior upon the whole to any other apparatus for propelling steam vessels, it still possesses several defects, the chief of which are the waste of power caused by the oblique action of the floats, and the swell caused by the back water, especially in narrow and crowded rivers, where small boats and deeply laden barges are frequently swamped. The same cause also, more perhaps than any other, has opposed the adoption of steam in canal navigation, as the swell caused by the paddles has been found to destroy the banks rapidly.

These defects of the ordinary wheel, which are universally admitted to a certain extent, although their importance is differently estimated, have been felt from the commencement of steam navigation, and the attention of the mechanical world has been occupied to devise modifications of it, or substitutes for it, which shall be free from them. In fact, it has become a sort of mechanical hobby, and perhaps more patents have been taken out for improvements in propelling, than for any one subject, the steam engine only excepted.

*Galloway's Cycloidal Paddle-Wheel.*—In 1835, Mr. Elijah Galloway obtained a patent for a paddle-wheel, which is free from many of the objections to which other inventions for the same object are liable. It is equally simple as the common wheel (of which it is in fact a modification), and is as little liable to derangement, and from the extensive adoption of it in steam vessels of all descriptions, we may infer that it possesses considerable advantages, having the whole depth of the float of one unbroken area; the floats are in divided portions, whereby the concussion on entering the water, and the amount of the back water, are greatly reduced.



*a a* in the figure, which is a side elevation of the wheel, represents the circle, or course of the outer edges of the floats; and *b b* the circle bounding the inner edges of the floats; *g g g g* are a series of portions of floats, which are set on curved lines, approximating to the cycloidal line *d f* at their outer edges, and are securely affixed to the paddle-wheel by screw-bolts and nuts or other means. Now it will be obvious, if the paddle-wheel be supposed to be revolving in the direction of the arrow, and the vessel going at such speed as that her velocity is equal to that of the inner circle *b b*, then the bars constituting one paddle would enter the water at the point *f* or nearly so, and displace

very little more water than that disturbed by the lowest bar. Thus the waste of power attendant on the common radial float board is obviated, and the concussion produced thereby almost entirely avoided.

*Gemmel's Paddle-Wheels.*—We have already noticed Mr. Gemmel's twin-boat in our second section. In the same patent (1837) he proposed to employ two pair of paddle-wheels of the ordinary construction to steam vessels generally, with a view to enable them to attain a speed adequate to the power of the engine employed, and that even when the breadth of the wheel is necessarily restricted, to enable the vessel to pass through narrow openings, such as the gates of canals, &c. One of his arrangements for these purposes is exhibited in the accompanying figures 1 and 2, the former being a longitudinal section

of the vessel, with a side elevation of the machinery, and the latter a plan of the same.

Fig. 1.

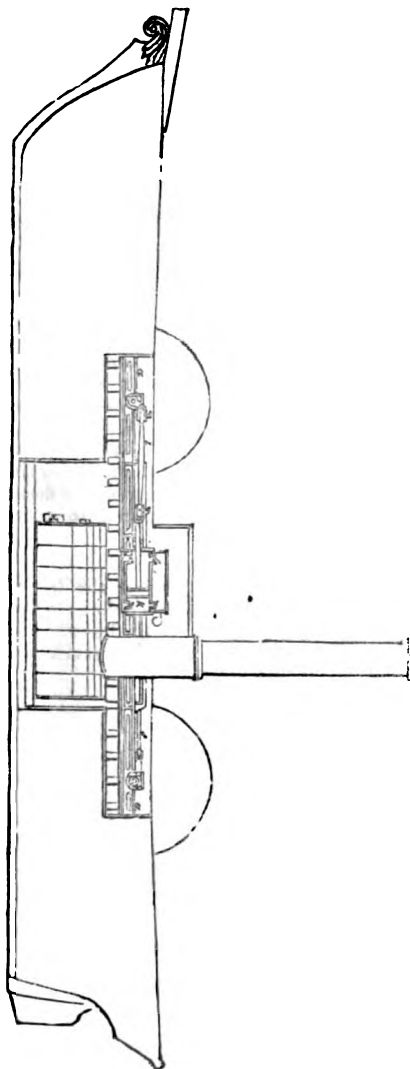
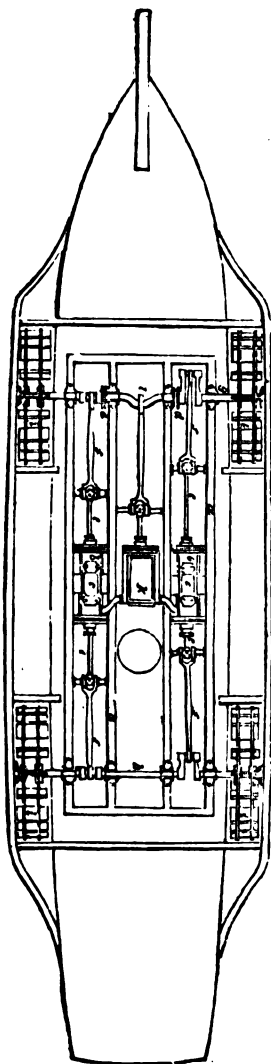


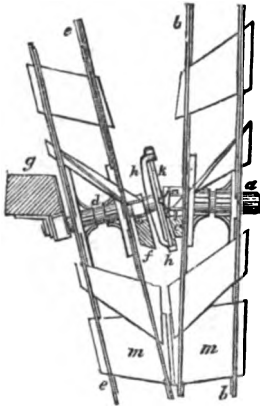
Fig. 2.



In a suitable metallic framing *a a a*, are fixed a pair of marine engines, working horizontally; *b b* are the working cylinders, *c c* the slide-valve cases, *d d* the eccentrics by which the valves are worked; but the rods are omitted to avoid confusion in the engraving; *e e e e* piston-rods, proceeding from each side of the pistons, and working through stuffing-boxes in the two covers of each cylinder. To maintain the parallelism of the piston-rods, their

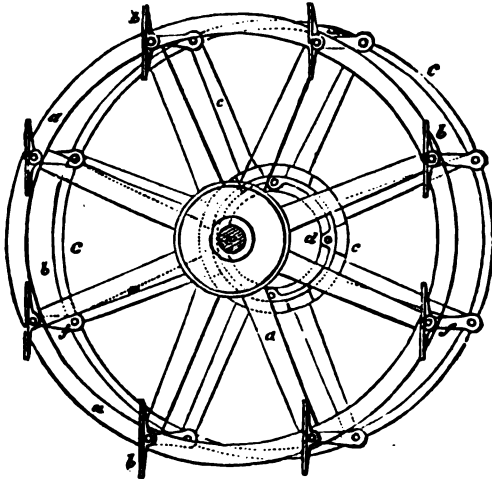
cross head; move in horizontal guides. *ffff* are the connecting rods, proceeding from the cross heads of the piston-rods to the cranks upon the two shafts *g* and *h*, which carry the two pairs of wheels *iii*. The air-pump *k* is placed between the two engines, and is worked by a short crank *l*, formed in the middle of the shaft *g*; *m* is the boiler, and *n* the chimney.

**Galloway's Oblique Double Wheel.**—In this invention two wheels are placed at each side of the vessel, the axes of which wheels do not lie in the same right line, but form an obtuse angle with each other. The axes are connected by a universal joint, so that the wheels revolve together, and the floats being set obliquely to the axes of the wheel, the descending floats in the two wheels approach each other on entering the water, so as to retain it between them, in the action of propelling, whilst the ascending floats as they leave the water gradually separate, so as to avoid lifting the water as they rise out of it.



The accompanying cut gives an end view of the wheels, with the descending or entering floats; *s* is the inner or driving shaft which carries the wheel, *b* the outer end of the shaft, turning in a plummer block on the spring beam *c*, *d* is the outer shaft carrying the wheel *e*, and working in bearings attached to the spring beams *f* and *g*; *h* *h* a cross arm keyed on to the inner end of the outer shaft *d*, and the extremities of which are connected by two drag links *k* *k*, to a similar cross arm on the outer end of the shaft *a*, thus constituting a universal joint, by which the motion of the shaft *d* is effected; *m* *m* are the descending floats, the ascending ones being omitted to avoid confusion.

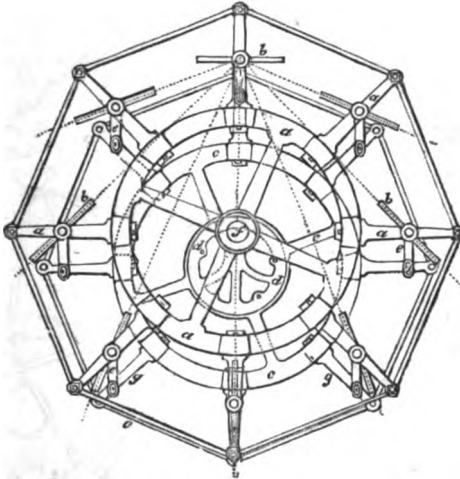
**Buchanan's Parallel Float Wheel.**—With the view to obviate the loss of power which has place in the ordinary wheel, owing to the oblique action of the radiating floats, Mr. Buchanan invented a wheel in which the whole of the paddles constantly preserve a vertical position during the entire revolution. The annexed figure is an elevation of Mr. Buchanan's wheel.



*a* *a* is the paddle-wheel, *b* *b* the floats attached to spindles working in the rims of the wheel; *c* *c* a guide wheel revolving on an eccentric disc or ring *d*,

fastened to the vessel's side; the main shaft *e* passes through the ring or disc: on to each of the spindles of the paddles, is keyed a crank *ff*, the length of which is exactly equal to the distance between the centre of the paddle-wheel and the centre of the guide wheel, and in the guide wheel are a number of pins which work in the other end of the cranks. The diameter of the paddle-wheel from centre to centre of two opposite spindles being exactly equal to the diameter of the guide wheel at the centre of the pins, the guide wheel is drawn round by the cranks with the same velocity as the paddle-wheel, and the cranks retaining their parallelism throughout the revolution of the wheels, the paddles attached to spindles of the cranks of course do the same and are kept constantly vertical.

*Oldham's Vibrating Float-wheel, (1827.)*—This wheel in its general appearance and construction, greatly resembles Buchanan's invention already described, but by an extremely ingenious arrangement, the paddles, instead of being constantly vertical and parallel to each other (as in Buchanan's wheel), are constantly varying the angles which they form with each other, and are in every part of the revolution directed to the highest point of the wheel, or of the circle in which their axes are situated. By this peculiar position of the paddles the wheel is capable of working at any depth of immersion. The annexed figure is a side elevation of Mr. Oldham's wheel.

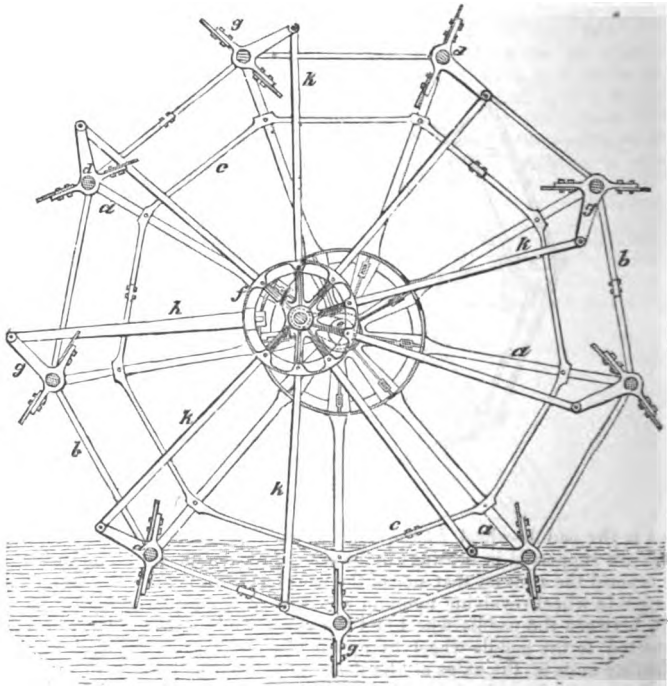


*a a* is the paddle-wheel, *bb* the floats or paddles, fastened to horizontal axles which are supported in bearings in the arms of the paddle-wheel, and which project beyond the arms on that side of the wheel which is nearest the vessel's side; *c c* a guide wheel revolving upon an eccentric disc *d*, placed upon the main shaft, between the paddle-wheel and the vessel's side. The guide wheel *c c* is connected to the paddle-wheel by means of short cranks, *e*, keyed on to the projecting ends of the axles of the floats, and having holes in their other extremity, in which work pins set in the face of the guide wheel. The length of these cranks must be exactly equal to the eccentricity of the disc *d*, and the distance of the pins in the face of the guide wheel, from the centre of the disc, must be equal to the distance of the float axles, and with these proportions the cranks will in all positions of the guide wheel remain parallel to each other. The eccentric disc is attached to a tube or long collar passing through the vessel's side, and the main shaft *f* of the paddle passes through the tube. The collar or tube revolves in bearings fixed upon the vessel's side, and upon the inner end is fixed a wheel working into a wheel, upon an intermediate shaft, which shaft



carries a second wheel, working into a wheel on the main shaft. These four wheels are so proportioned, that two revolutions of the main shaft shall cause the eccentric disc to revolve once upon the main shaft; thus, whilst the guide wheel by its connexion to the paddle-wheel revolves upon the disc, the disc itself is also revolving upon the shaft. All the paddles are fixed upon their spindles at different angles with the connecting cranks, so as to stand in the position shown in the figure; and as the disc during half a revolution of the wheel performs a quarter of a revolution on the shaft, the cranks, which in the figure are all vertical, would in half a revolution of the paddle-wheel stand horizontal, and therefore the whole of the paddles would in that time describe a quarter of a revolution on their axes, and the paddle which stood in a horizontal position at the top of the wheel, would, when at the lowest point of the wheel, stand vertically.

*Morgan's Vibrating Float-wheel.*—This wheel, although commonly known as "Morgan's Wheel," is in reality the invention of Mr. Elijah Galloway, who obtained a patent for the same in 1829. This patent was subsequently purchased by Mr. Morgan, who has since introduced several material improvements upon the original design. The annexed figure represents the wheel in its improved form as constructed by Mr. Morgan.



*a a* are the arms of the outer frame of the wheel, which are braced together by the two polygons *b* and *c*, and are connected to the arms of the inner frame of the wheel by strong transverse horizontal stays *d d*. The paddle shaft does not extend beyond the boss of the inner frame, which is firmly keyed to it; the outer frame revolves upon an arm *e*, passing through its centre, and keyed into a carriage supported by the spring beam. This arm is formed into a crank between the outer and inner frames, and the pin of the crank supports the revolving collar *f*. *g g g* are brackets or stems which turn upon the stays *d d*,

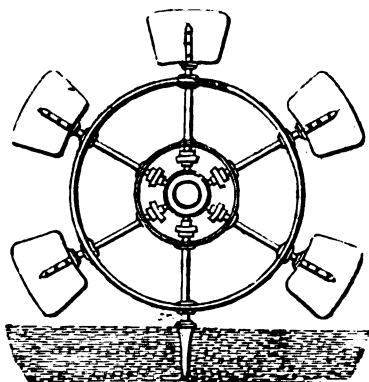
and carry the floats or paddles. One of these stems is connected to a stiff rod or arm *h*, which is keyed into the collar *f*; the other stems are connected to the collar by the radius rods *k k*, which turn upon pins in the collar and in the ends of the stem. The revolution of the wheel causes the collar to revolve by the action of the arm *h*, and the radius rods cause each paddle to assume in succession the positions shown in the figure.

*Dawson's Radiating Feathering Paddle-wheels.*—The distinguishing feature of these wheels is that the floats or paddles revolve or vibrate upon radiating arms or axes, so as to enter and leave the water edgeways, the planes lying parallel to the keel or nearly so, but standing at right angles to it when fully immersed. The following description is abridged from Mr. Dawson's specification, published in the Repository of Arts:—

*Fig. 1* represents a wheel the paddles of which gradually change their position as they enter and quit the water, which change is effected by affixing on the axis of each paddle two wipers *a b* crossing each other at right angles and of the form shown in *Fig. 2*. To the side of the vessel is fixed an immovable plate, on the surface of which are three projecting arcs *c d e*, being portions of circles, as shown in *Fig. 3*.

One of these arcs is immovable, (describing three parts of a circle;) another, *d*, draws in and out on guiding rods by a lever acting through the sides of the vessel, the third arc *e* slides up and down the fixed arc *c*; the use of this sliding arc *e* will be particularly pointed out hereafter. For the purpose of

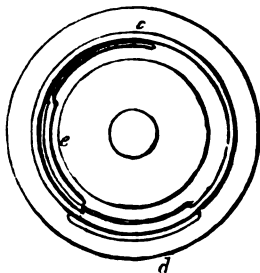
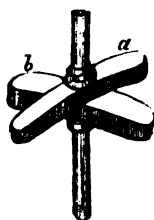
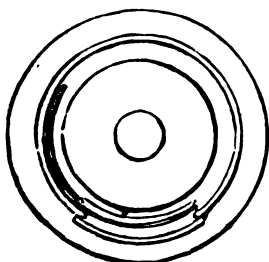
*Fig. 1.*



*Fig. 4.*

*Fig. 2.*

*Fig. 3.*



effecting the change of position of each paddle gradually and without shock, both the fixed and movable arcs terminate at each end in inclined planes. If these are made long and the wipers in proportion, the motion will be very gradually performed. When the wheel is made to revolve, the point of the wiper *a* of the paddle entering the water encounters the commencement of the inclined plane of the movable projecting arc *d*, rolls up it, and the paddle is thereby gradually turned one fourth of a circle on its axis; by which means the position of the paddle is changed from the edge on which it entered the water to full surface, in which position it is retained by the movable arc *d*, and may be made to act for any determinate space, say from *f* to *g*. The other wiper *b* then encounters the inclined plane of the immovable arc *c*, rolls down it, and the paddle is thereby gradually turned another quarter of a circle on its axis, by which means it is turned round to the opposite edge on leaving the

water. In this position it is retained by the fixed projecting arc and again encounters the water.

Supposing it was required, with the view of obtaining a greater action on the wave, that the paddles of a feathering wheel should exceed three or four feet in breadth, say six or eight feet, it is obvious that the friction and difficulty of effecting the change of position in the paddles would be materially increased, and the number of paddles would be limited. Under these circumstances, instead of making a double feathering wheel, that is, of joining two wheels of three feet together to obtain the breadth required, I prefer constructing a feathering wheel with paddles three feet broad, on each side of which I fix shrouding boards *h h*, of twenty inches width, at a certain angle; by this means I avoid all increase of friction, check the lateral escape of the fluid from the paddles, and obtain a commensurate surface for the water to act on. Each paddle *i* and its fixed shrouding boards *h h* enter the water on their edges; as the wheel revolves, the paddle changes its position and presents its full surface, and thereby closes the open space between the boards, after a given time it gradually opens as it rises out of the water, and returns to its first position on the edges. By this arrangement, although the surface of action is increased, the ease of entering and escaping from the water is retained; and, according as the arcs are fixed on one side or the other of the wheel, the water will be thrown off the paddles in or out from the sides of the vessel.

It has been fairly objected to wheels on the above construction, that they are expensive, complicated, and work with much more friction than the wheels commonly employed. To obviate these objections I constructed the wheel shown in *Figs. 6 and 7*. The paddles of this wheel are formed of two boards posited at a certain angle face to face

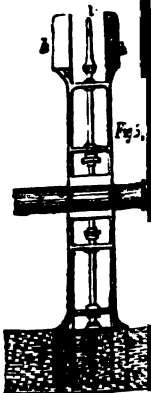
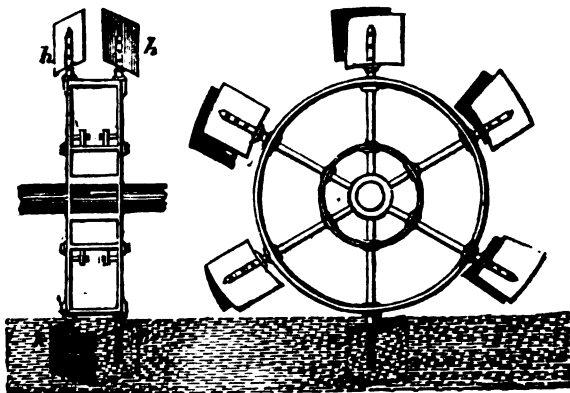


Fig. 6.

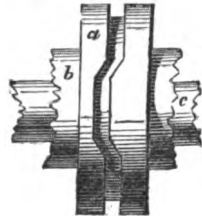
Fig. 7.



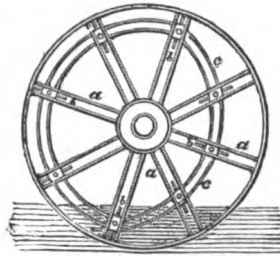
on their respective axes, leaving only a space sufficient for the free escape of the water between; in this position they are retained by stops from opening any farther. When the wheel revolves, the water acting on the broad surface of the paddles causes them to close as they enter the water, and to remain so until they begin to rise out of it, when the weight of the water lodging on the narrow surface only, causes them to open, and in consequence, the water falls through without being lifted.

*Head's Patent Paddle-wheels*, (Dec. 18, 1828.)—The principle of this invention is identical with one of those patented by Dawson in 1814, already

described. Each paddle consists of two leaves, fixed to radiating and revolving spindles, supported at the outer end by a cross bar attached to the opposite arms of the wheel, and at the other end by a similar bar attached to the two bosses. That part of the paddle shaft which lies within the bosses of the wheel is surrounded by a tube or collar, which passes through one of the bosses, and is fastened to one side of the paddle-box, so that it remains stationary whilst the wheel revolves. Upon this collar are fixed two bosses, in the periphery of each of which is cut a groove composed of portions of two parallel circles, connected by two oblique channels as shown in the diagram; in which *a* is the grooved boss fixed upon the collar *b*, and *c* the paddle-shaft revolving within the collar.

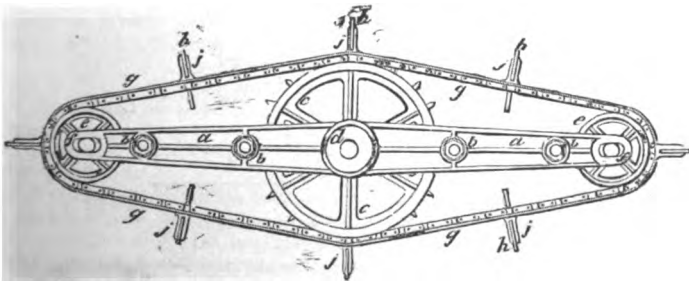


*Leeming's Eccentric Sliding Floats*, (1835).—The object of these improvements is to diminish the resistance of the back-water; with this view the arms *a a* of the wheel (which are fixed radially), have grooves extending the greater portion of their length, and in these grooves the paddle boards *b b* are placed; an eccentric groove *c* is fixed to the side of the vessel, and a corresponding groove is also fixed to the spring beam of the paddle-box, and a pin in each end of the paddles works in these grooves and regulates the distance of the paddle from the centre of the wheel. The eccentric grooves are so placed as to cause the entering paddles to stand at the extremities of the arms, so as to act with full effect; but after passing the perpendicular the paddles are drawn by the action of the eccentric grooves nearer to the centre of the wheel, so as to lift less back-water as they rise out of the water.



*Endless Chain Paddles*.—With the view of obtaining a direct impulse in the line of the vessel's motion, in lieu of the oblique motion imparted by the ordinary paddle-wheel, trials have been made at various times of floats attached to endless chains, passing over two drums placed at the sides of the vessel at a considerable distance asunder.

*Spurgin's Endless Chain to Wheel*.—The accompanying engraving represents an arrangement of a propeller on this principle, for which Dr. Spurgin obtained a patent in 1837. It possesses some advantages over preceding arrangements on the same principle, each paddle of the chain being made to enter and leave the water at the angle required to produce the most effective action. For this

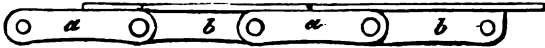


purpose, instead of employing only two pair of riggers to carry the endless chain, three pair are employed, the central pair being either of greater

diameter than the pairs at each end, or having its axis placed lower than the axes of the other two, so as to cause the lower sides of the chain to stand obliquely to the water, instead of parallel thereto, as in all previous propellers of this class; by this obliquity of the chain the paddles standing at right angles thereto are made to enter and leave the water at a corresponding angle.

The figure represents a side elevation of the apparatus. *a a* is a cast iron frame secured to the sides of the vessel by the bolts *b b b b*, *c* is one of a pair of spike wheels fixed on the engine shaft *d*, *e e* riggers or pulleys running upon the pins or studs *f f* at each end of the frame, *g g* an endless flat chain passing round the riggers *e e*, and over and under the spike wheel *c*: in order to keep this chain tightly extended, the studs *f f* move in slots in the frame *a*, and are keyed up by any convenient method, so as to give the requisite tension to the chain; *h h* are the floats which are carried by the iron forks *j j*, which are forged in one with the middle links which support them.

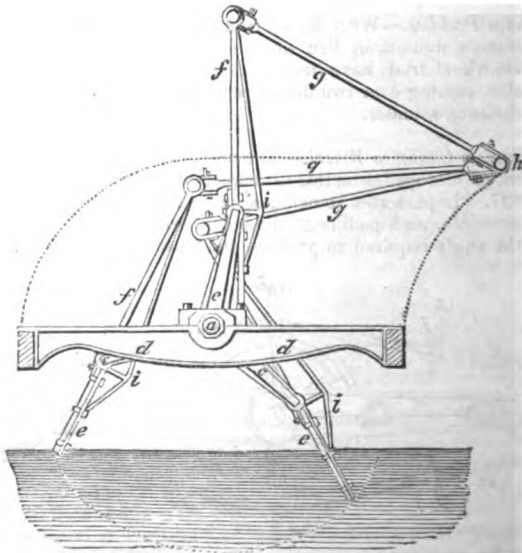
Another improvement specified under the patent consists in the mode of constructing the chain. It is formed of single and double links alternately, the single links having on their backs a flange as broad as the double links, and projecting lengthwise half way over each double link, so that the flanges of the two contiguous single links abut against each other as shown in the figure, which represents a side elevation of a portion of the chain.



*a a* are the double links, *b b* the single links, and *c c* the flanges on the backs of the single links.

*Stevens's Crank Axle Paddles*, (1828).—In this invention three paddles are attached separately to the arms of a three-throwed crank, and by means of radius and guiding rods connected with them, the paddles are each made to describe in the water the segment of an ellipse.

Fig. 1.



At *a*, Fig. 1, is the centre of the axis of a triple crank, the separate arms of which (marked *c c c*,) move between parallel bars on the side frame *d d* of the

paddle-box. At *eee* are the three paddles, connected by the guide rods *fff* to the radius rods *ggg*, the latter working from a fixed beam or centre *h*. At *iii* are "arched spreaders" to keep the paddles firm and steady. *Fig. 2*, which represents a section through the horizontal beams *dd* shown in *Fig. 1*, is added, for the better explanation of the parts than could be done by words. This invention was much admired for its ingenuity when brought out.

*Nairn's Propelling Apparatus*, patented in 1828, is an example of what is termed the "Ducksfoot motion," consisting of two, four, or more levers suspended over the sides of a vessel, descending nearly as low as the vessel's keel. These levers are made to vibrate by the engine, and in order that they may experience but little resistance from the water in their back stroke, they should be of such a shape as to present in their horizontal section a form like the adjoining *Fig. 1*. At each side of the lever, at its lower extremity, is attached a broad plate of iron *a a*, *Fig. 2*, by means of hinge joints, which, upon the lever being moved forward, close and offer no resistance, but when it is moved backward, they open or expand, and thereby propel the vessel forward. They are prevented from opening beyond their proper angle by arcs or chains.

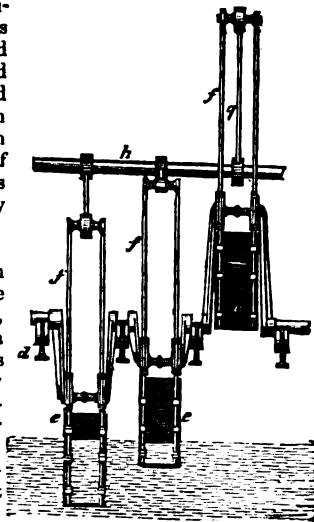


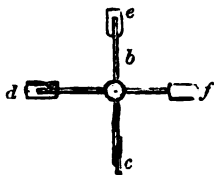
Fig. 1.



Fig. 2.

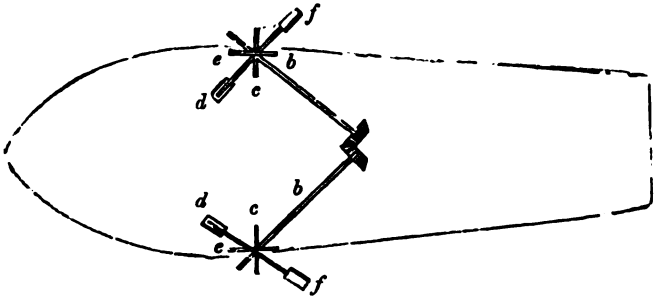
*Perkins's Sculling Paddle-wheels*.—In 1829 Mr. Perkins obtained a patent for the following mode of propelling, which may be considered as an example of sculling motion. Mr. Perkins places each of his paddles on the extremity of a radiating arm, in such a position that its plane if produced towards the centre of motion, would make with the axis of the paddle-wheel an angle of 45°. The axes of the paddle-wheels are not carried across the vessel, in the customary manner, but are carried in a direction sloping towards the stern, and they meet in a point in a straight line from stem to stern along the middle of the vessel, making with it an angle of 45° each, and with each other of 90°. On the extremity of the axis are fixed bevel wheels, which act upon each other, and are both acted upon by an intermediate wheel in connexion with the steam engine or first mover.

By this arrangement, the surface of each paddle, when immersed in the water at its greatest depth, is perpendicular to the side of the vessel, or to the line of motion, as represented at *c*, in the annexed figure in the marginal cut; at their greatest elevation, each paddle is parallel to the line of motion, as at *e*; and when in the horizontal position, whether ascending or descending, the paddles present an angle of about 45°; and, from the angle it deviates but little when in the act of entering or leaving the water, as the patentee proposes to immerse the wheel to about one-fourth of its diameter.



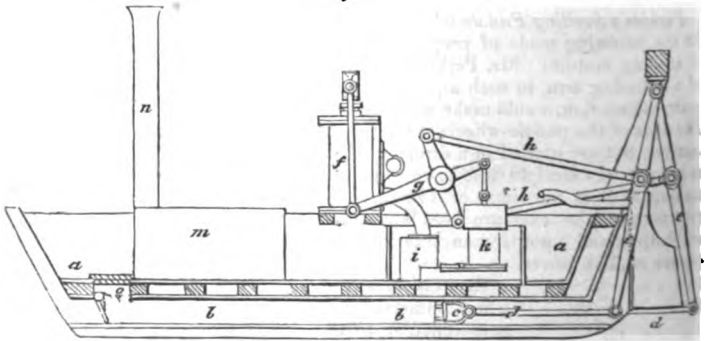
The annexed figure is intended to represent the outline, in plan, of a vessel with these paddles attached. At *a* is the boat, *b b*, the paddle axle, to which a uniform motion is given through the medium of the bevel gear which connects them; *c c* are two of the paddles immersed in the water, and in the act of

propelling; *d d*, *e e*, and *f f*, are those paddles which succeed each other in the revolution. The oblique action of the blades of the paddle, as they perform their revolutions, will be understood by reference to the cut before explained.



*Linnaker's Propelling Pumps*, (1808).—Mr. Linnaker proposed two plans for propelling vessels by means of pumps: in the first the pumps were placed horizontally beneath the vessel's bottom, and in the second, a pump was placed vertically within the vessel, and communicated with two horizontal channels formed below the vessel's bottom. The first plan is shown by *Fig. 1*, which represents a section of the boat, and the propelling machinery. *a a* is the vessel, which is flat bottomed, *b* one of two rectangular trunks which extend one on each side of the keel the whole length of the bottom. In each trough is a rectangular plunger *c*, fitting the trough, and connected by the rods *d d* to the hanging levers *e e*. These levers are worked to and fro by the steam engine *f*,

*Fig. 1.*



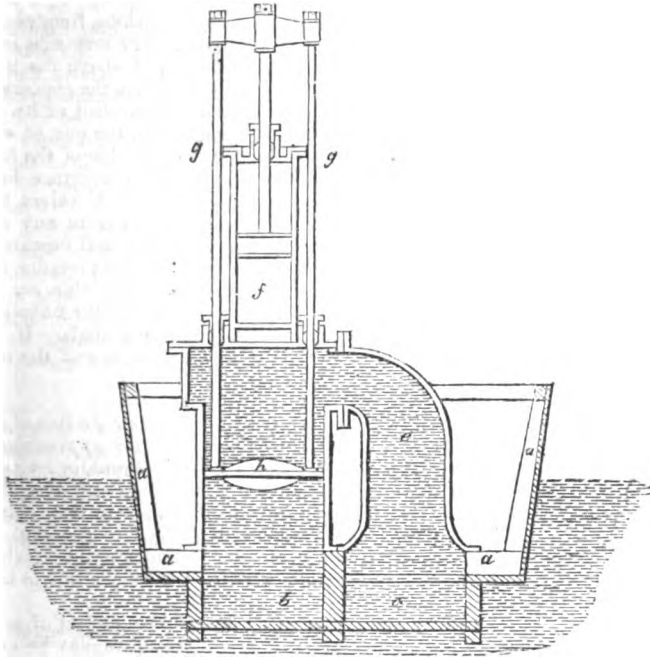
acting upon the bell-crank lever *g*, the cross arms of which are connected to the levers *e e* by the rods *h h*; *i* is the condenser, and *k* the air pump, *m* the boiler, and *n* the funnel; *o* is a hanging valve, in the fore part of the trunk, and opening towards the stern. At each ascending and descending stroke of the engine, one of the plungers is thrust forward and the other backwards, and by the latter motion the water is drawn in at the valve *o*, and expelled at the hinder end of the trough.

Mr. Linnaker's second plan is similar in principle to the preceding, but the general arrangement is better, and more complete. It is shown in *Fig. 2*, which represents a transverse section of the vessel and propelling apparatus.

*a a a a* is the frame of the vessel, which, as in the former instance, is flat

bottomed, *b* and *c* two rectangular troughs formed below the bottom, and extending the whole length of the floor, *d d* is a large vertical pump communicating below directly with the trough *b*, and connected at the upper part with the other trough *c*, by the elbow pipe *e*; upon this pump is fixed a vertical

Fig. 2.



steam engine *f*, and to the cross head of the piston-rod are attached two side rods *g g*, which pass through stuffing-boxes in the cover of the pump, and are attached to the piston *h* of the pump. The troughs are furnished at each end with a double set of hanging valves, so as to admit of reversing the motion of the boat, which is effected by merely turning a lever, which throws one set of the valves out of action, and puts the other set in operation.

The action of this apparatus will be readily seen; at each stroke of the engine the pump draws in water from the bows by the one trough, and expels at the stern water from the other trough, which by the reaction gives motion to the vessel.

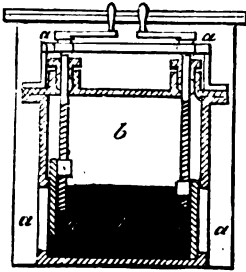
*Busk's Hydraulic Propellers.*—The principle of this plan of propelling vessels has been termed the “reactionary principle;” it is thus explained by the patentee.

It is well known that water contained in a vessel has a tendency to drive out the sides, or burst such vessels by pressure in every direction in proportion to the perpendicular height at which the water stands; and it is also well understood that if an opening be made at any part of the vessel, the pressure on that part will be relieved by the flowing of water therefrom, at the same time the pressure in all other directions remains the same, so long as the head of water is maintained at one water-line; and it will readily be understood, that if the vessel were free to move, and had no opposing force greater than the unbalanced internal pressure on the side of the vessel opposite, the opening would cause the



vessel to move in a direction opposite to the opening, such action resembling in principle the working of the hydraulic machine called Barker's Mill.

The mode in which this principle is to be applied to propel vessels may be thus described :—



*a a* in the figure represents a tank or cistern erected in any convenient part of the vessel, and supplied with water by a steam engine; *b b* is a section endways of a trunk branching from one side of the tank, and projecting over one side of the vessel at any convenient height above the water-line, a similar trunk projecting from the opposite side of the tank. Each trunk is furnished at its outer extremity with two sluice valves, the one of which (*c*) covers an aperture in the fore-side of the trunk, and the other (*d*) covers a similar aperture in the hinder or after side. Now if, both valves being shut, the tank be filled with water to any given

height, the pressure upon the fore-side tending to propel the vessel forward will be as the pressure of the column of water; and supposing the pressure to be one pound per square inch, and that the sluice valves on each side are each twenty-five inches wide, then if the valves are raised one inch, the unbalanced pressure tending to urge the vessel forward will be fifty pounds. If it be desired to give the vessel stern way, the valves *d* must be closed, and the valves *c* opened.

*Screw Propellers.*—The idea of propelling vessels by a screw (in lieu of oars) is of ancient date; it is mentioned in the "*Machines et Inventions approuvées par l'Académie Royale des Sciences depuis 1727 jusqu'à 1731.*" Franklin long afterwards suggested the same thing, but expressing doubts at the same time of any advantages to be obtained by the plan. In this country a patent was obtained in 1794 by a Mr. Lytleton for "An Aquatic propeller," consisting of a screw of one, two, or more threads wrapped round a cylinder, and revolving in a frame placed at the head, stern, or side of a vessel. We believe this to be the first patent for a screw propeller.

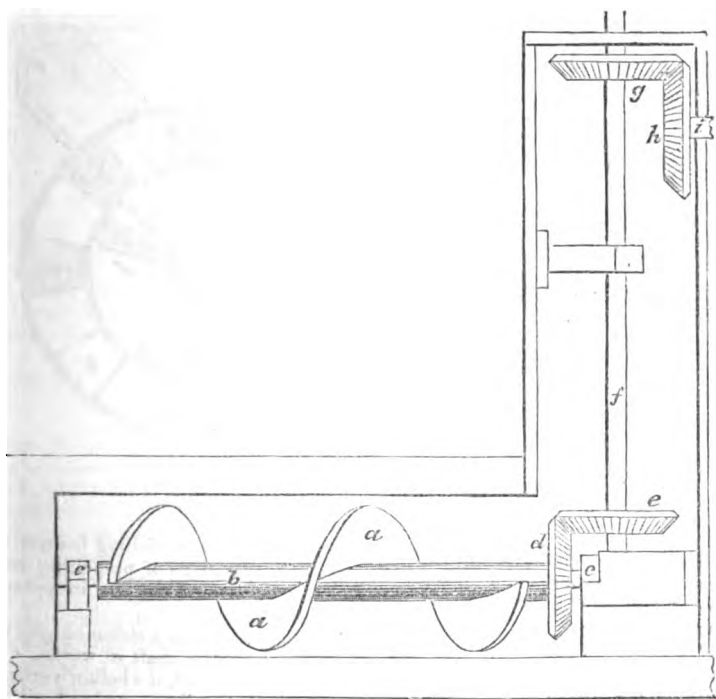
Various modifications of the screw have since formed the subject of several patents, but it is only within a few years that screw propellers may be said to have come into operation.

*Smith's Archimedean Screw Propeller, (1836.)*—The annexed engraving represents partly in section the patented invention of Mr. F. P. Smith, to whose perseverance and energy is mainly owing the establishment of screw propelling.

*a a* is a screw or continuous spiral blade wound round a cylinder *b*, turning in bearings at *c c*; at *d* is a mitred wheel fixed to the shaft, and actuated by the mitred wheel *e* affixed to the vertical shaft *f*, at the upper end of which shaft is another mitre wheel *g*, which is driven by the wheel *h* fixed upon the engine shaft *i*; the screw works within an open space formed in the deadwood of the vessel, and the vertical shaft works in a well which is open both at top and bottom, so that the water rises to the level of the water line of the vessel. The shaft is steadied by one or more bearings *k* according to its length.

Mr. Smith constructed a vessel (which he named the *Archimedes*,) for the purpose of testing the merits of this mode of propelling, and the results were most satisfactory. In July, 1840, the vessel made an experimental voyage round this island, *viâ* Portsmouth, Bristol, Liverpool, Greenock, the Caedonian Canal, Inverness, Leith and Hull, and thence back to London. Up to her arrival at Hull she had steamed 1772 miles in 210 hours, being on an average about 8.2 miles per hour in all weathers and states of the tide. The government subsequently appointed a protracted trial to be made between the *Archimedes* and the *Widgeon*, a government steamer propelled by paddle-wheels, and from the success of the experiment were induced to order the *Rattler* steamer to be constructed with a screw propeller, and in this vessel experiments with

various modifications of screws have been made, which have firmly established the efficiency of the screw as a propeller, and it is now employed in numerous government vessels as well as private steamers.



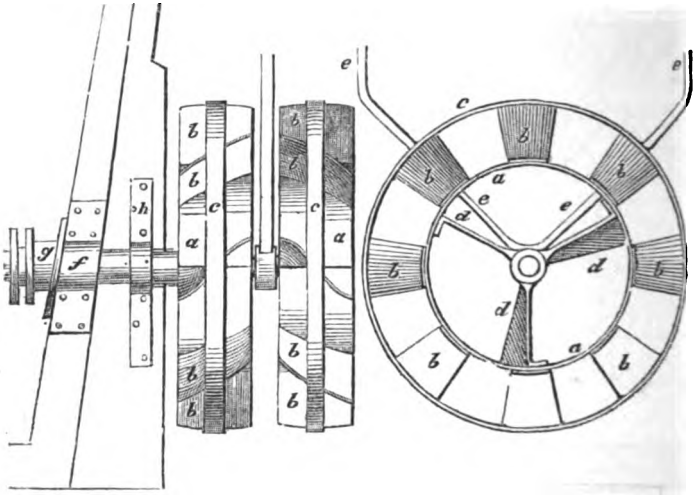
*Ericsson's Screw Propeller.*—In 1836 Captain Ericsson, a Swedish gentleman, well known for his mechanical talent, obtained a patent for an apparatus for propelling steam vessels. The invention consists in a modification of the water screw, or spiral propeller; but applied in a different manner to what has been usually proposed. *Fig. 1* is an end view, and *fig. 2* a side view of the apparatus.

Upon a broad cylindrical hoop *a* of wrought iron are placed light fans or vanes *b*, in an oblique, or rather a spiral direction, as the wheel may in fact be considered as a short portion of a screw of eight threads, the rake of which is about equal to the external circumference; or one turn of the screw would advance it through a space equal to the circumference. These fans are firmly riveted to the hoop *a*, and also to a narrow hoop *c* at their outer edges; and the hoop *c* is connected to its shaft by three broad wrought-iron arms *d*, set at such an angle as to offer the least possible resistance to the passage of the wheel through the water. Two of these wheels are suspended from the stern, by a strong framing *e*; the shaft of the outermost wheel passes through the shaft of the inner wheel (which is made hollow to receive it); and both shafts pass through an iron socket *f*, in the stern post, and through a stuffing box *g*, fixed on the stern post within the vessel, to prevent the entrance of the water. The set of vanes upon the two wheels stand in opposite directions; and the two shafts are connected to the engine in such a manner that the two revolve in contrary directions, and the outer wheel about one sixth faster than the inner one. As the shafts pass through the rudder, the upper and lower portions

are connected by a broad iron stay *h* on each side, of such form as to allow the necessary vibration of the rudder. The wheels are entirely immersed under the water.

Fig. 2.

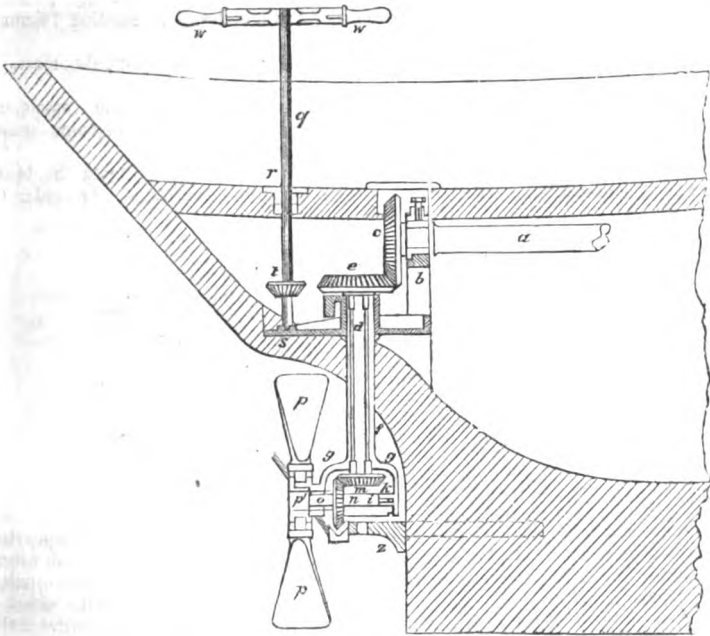
Fig. 1.



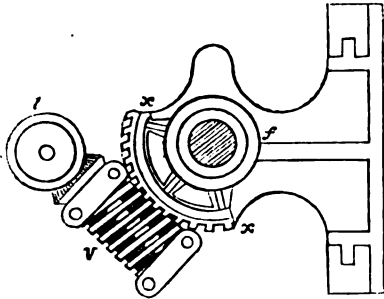
*Hunt's Steering and Propelling Apparatus.*—The distinguishing feature of this apparatus consists in its combining the two operations of propelling and steering in one. The following description we quote from the inventor's specification :—

"*a* is a driving shaft, connected in the usual way with a steam engine or other first mover; *b* an upright bearer on which the shaft *a* works, *c* a bevelled cog-wheel, attached to the end of the driving shaft, *d* a hollow vertical shaft (made hollow for the purpose of receiving occasionally a supply of oil to lubricate its different bearing points) which passes down, right through the stern of the vessel close to the water line, and reaches outside to near the keel, where it rests in a projecting heel-piece, *h*, bolted firmly to the keel or keelson, carrying at top a second cog-wheel *e*, which takes into the first cog-wheel *c*, and at bottom a third cog-wheel *m*, which takes into a fourth *n*, which acts immediately on the propellers hereinafter mentioned; *f* is a case which encloses the vertical shaft *d*, and is connected with it at top and bottom by gun-metal bearings; *g* a trunk (formed by an enlargement at the bottom of the case *f*) which encloses and protects the third and fourth cog-wheels *m* and *n*, and is made of brass or some other metal not readily oxidizable; *i* is a short horizontal shaft on which the fourth cog-wheel *n* is fixed, one end of which shaft rests in the bearing *k*, inside of the trunk *g*, and the other passes through the trunk *g* into a coupling box *o*; *p p* is a nave or boss at the end of the coupling box, into which are fixed, at right angles the one to the other, the four blades or propellers *p*, by which progressive motion is given to the vessel. So much of the apparatus as I have hereinbefore described, is employed solely for propelling purposes, and its mode of operation is as follows:—The driving shaft on being set in motion by the steam engine or other first mover turns the first cog-wheel *c*, which turns the second cog-wheel *e*, which (through the medium of the shaft *d*.) turns the third cog-wheel *m*, which turns the fourth or last cog-wheel *n*, which turns the shaft *i*, which (through the medium of the coupling box *o*, and boss *p p*.) causes the blades or propellers, *p*, to rotate and thereby propel the vessel. The steering part of the

apparatus I shall now proceed to describe. *ww* are the arms of a steering wheel fixed on the top of a vertical shaft *g*, which passes through the vessel's



deck, turning freely on its centre in the bearing *r*, and resting at bottom in a socket *s*. On this shaft a bevelled cog-wheel *t* is fixed, the cogs of which work into a corresponding set of cogs at the end of a horizontal screw shaft *v*, which takes into a quadrant *x*, (separately shown in the adjoining cut, but omitted for sake of clearness in the preceding figure,) which is attached to the top of the case *f*, which encloses the vertical shaft *e*. It follows from the series of combinations last described, that according as the steersman turns the wheel to the one side or the other he must turn to one side or the other the quadrant *x*, which is attached to the top of the case *f*, which governs (through the medium of the shafts *d* and *i*, and the gear work in connexion with them) the position of the propellers, *p p*, and so cause the propellers always to act in a line exactly coincident with that desired to be given to the vessel."



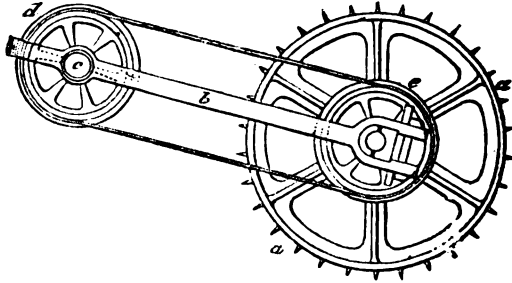
*Canal Navigation.*—The application of steam to the navigation of canals has long been considered a desideratum, and many plans have been brought forward for the purpose, but none have been permanently adopted. Amongst the obstacles to its introduction, is the swell caused by the propelling apparatus, which is so destructive to the banks, that unless it could be obviated, it would go far to counterbalance any advantages which might otherwise attend the use

of steam. Another obstacle is found in the narrowness of the locks, which leave little space for the fixing of the propellers at the side of the vessel. On the other hand, canals admit of the application of modes of propelling, by which a fixed fulcrum can be obtained in lieu of the yielding or receding fulcrum which is afforded by the water.

We shall notice a few of the inventions designed especially for this object.

*Seaward's Spike Wheel.*—Messrs. Seaward's plan for propelling vessels on canals and other shallow waters consists in the employment of a circular thrusting instrument or spike-wheel to act continuously.

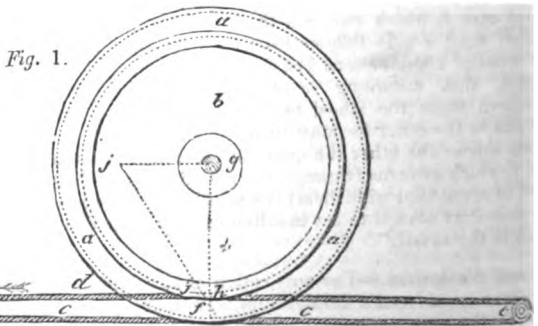
In the annexed cut, *a* is the spike-wheel, working either outside the boat, or in a compartment within the vessel, but open at bottom. In order to



accommodate the wheel to the inequalities of the bed of the canal, it is supported by bearings at the extremity of a swinging frame *b*; the other end of which is hung to a shaft *c*, turned by a steam-engine; on this shaft is fixed a pulley or drum *d*, and a similar pulley or drum *e* is fixed on the axis of the wheel *a*, and an endless belt or chain being passed round the wheel, the revolution of the drum *d* causes the spike-wheel to revolve, and thereby propel the vessel.

*Saxton's mode of Propulsion on Canals* (1833).—This invention is intended for propelling light vessels at a high velocity on canals. It consists in a novel and ingenious application of the converse principle of the arrangement commonly known as the *Chinese* or differential crane, the latter being designed to move a great load through a small space, by a small force moving through a large space; whilst in this invention a small load is moved through a large space, by means of a great force moving through a small space.

In order that the invention may be fully understood, it will be necessary to

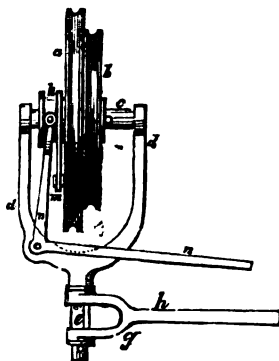


explain clearly the principle of it, before we describe the practical application. It is thus explained in the specification, which is given at length in the *Repository of Arts*.

*Fig. 1* represents a combination of two pulleys, their diameters being as six to seven; *a* being the larger pulley, and *b* the smaller one; *c d* is an endless rope, passing over the sheaves *e e*, which rope it should be observed takes a turn round each of the pulleys *a* and *b*, that is to say, the part *c* taking a turn round the larger pulley *a*, and the part *d* taking a turn round the smaller pulley *b*. If then the rope *d* be caused to move in the direction of the arrow, it will have a tendency to draw the lower part of the pulley *b* in the same direction; while the part *c* of the endless rope will be moving in an opposite direction, and will have a tendency to move the lower part of the pulley *a* in the same direction; consequently, the two pulleys *a b* (they being fixed together) would turn on the mean point *f*, as a fulcrum; *g* is the centre of the two pulleys. Let it then be supposed, that the part *d* of the endless rope be moved from *h* to *i*, it will be evident that the centre *g* of the differential pulleys *a b*, would be moved to the point *j*; and consequently if any object were connected to the centre *g* of these differential pulleys, it would be propelled from *g* to *j* by the endless rope being moved the much smaller distance of *h* to *i*, as is clearly indicated by the dotted lines; and these distances will be as thirteen to one.

We shall now describe the mechanical arrangement of the invention, as applied to propel vessels on canals.

*a* and *b* are two pulleys upon one axis *c*, the points of which turn in holes in the forked frame *d*, the stem of which (*e*,) turns in sockets *g g*, at the outer extremity of the arm *h*. The pulley *a* is fixed to the axis, but the pulley *b* is loose upon the axis; *k* is a sliding clutch upon the axis, carrying an arm *m*, in which is a pin passing through a hole in one of the arms of the pulley *a*; *n* is a bent lever turning upon a pin in the forked frame *d*, and having a forked extremity, which embraces the sliding clutch *k*. When by the motion of the lever the clutch is brought close to the pulley *a*, the pin in the arm *m* passes between the spokes of the pulley *b*; and when it comes in contact with one of them, it carries the pulley round with the pulley *a*, and the machine is then in gear. The opposite motion of the lever withdraws the pin, and the pulleys are free to revolve in opposite directions, and the operation of the machine is suspended.



The apparatus above described is supported over the side of the vessel by a vertical standard, which supports the arm *h* in a horizontal position; and the endless ropes are passed round the pulleys, as described, and through two riggers, placed one at each end of the canal. If power be applied to draw the rope by any method, as for instance, by means of a steam engine applied to turn one of the riggers, the vessel to which the apparatus is attached will be propelled, with a velocity which will be to that of the rope, as it passes over the rigger, in the ratio of the sum of the diameter of the pulleys, to their difference; thus if the diameters be as 8 to 9, the velocity will be as 17 to 1; and if the rigger turn with a speed of 2 miles per hour, the boat will be drawn at the rate of 34 miles per hour.

The rope must be supported upon rollers, placed along the banks of the canal, in order that it may run light; and the object of making the stem of the fork *d* turn in the sockets *g g*, is to allow the pulleys *a* and *b* to stand at an angle, by which the endless rope may be led into the sheaves when the carriage is going in a curved direction.

## SECTION V.

ON THE PREVENTION OF ACCIDENTS FROM EXPLOSION, COLLISION,  
FIRE, FOUNDERING, &c.

Paramount necessity of precautionary regulations.—Government commission for inquiring thereon.—Extracts from Commissioners' Report thereon.—Abstract of Accidents on board almost two Steam-boats.—Regulations adopted by the Dublin Steam Packet Company.—Overhauling and examinations of Vessels and Machinery.—Reports.—Alarming unsafe condition of the Boilers of many Steam vessels.—Primary causes of Accidents.—Explosions.—Fires.—Collisions.—Outline of proposed legislative regulations for the prevention of.—“Rule-of-the-road.”—Signals.—Captain Smith's Paddle-box boats.—Necessity of disengaging apparatus for Paddle wheels.—Murdoch's patent mode of effecting.—Act of Parliament for Regulation of Steam Navigation.

WHEN it is considered that steam-vessels are principally employed in the conveyance of passengers, and that from the extent of their accommodations the number of persons assembled together is usually very great, frequently amounting to some hundreds, the paramount consideration should be to guard against accidents, where the consequences may involve the most appalling sacrifices of human life.

With the rapid extension of steam navigation it was to be expected that accidents would become more frequent; and, in 1831, a committee of the House of Commons was appointed to inquire into the subject, with a view to recommend preventive measures. The committee examined a number of witnesses, and presented two Reports; but these were not followed up by any legislative enactment; although some bye-laws were passed by the Corporation of London for regulating the speed of vessels in that part of the Port of London called the Pool. In the course of the year 1838, however, in consequence of some accidents of a serious nature, especially two explosions which occurred on board of one vessel within a short interval of time, and by which, we believe, in the whole, sixteen persons lost their lives, the attention of the Government was, in a more especial manner, called to the subject. They in consequence appointed Captain Pringle, R.E. and Joseph Parkes, C.E. to undertake an inquiry into the cause of such accidents, and the means of preventing the recurrence of them; in order to lay the ground of some legislative measure for the security of the public.

The chief points to which their attention was directed were—

1st. The number and nature of the accidents which have happened in steam vessels, within the last ten years, as far as can be ascertained.

2d. The practical means for preventing the recurrence of accidents.

In order to obtain this information they were directed to visit the principal ports, to confer with the local authorities there, the owners and officers of steam vessels, and the most eminent constructors of marine engines.

In compliance with these instructions the commissioners drew up a series of queries, which they circulated amongst parties connected with steam navigation; they visited the ports of Liverpool, Glasgow, Greenock, Leith, Newcastle, Shields, Sunderland, and Hull; and personally examined various steam-vessels, some plying, and others undergoing repairs in their machinery and hulls; and received much valuable information from correspondents residing at places which their time did not permit them to visit. The substance of the information thus acquired is embodied in a well-digested report, in which most of the accidents are fairly traced to their true causes, and a number of valuable suggestions are

made for the prevention of their recurrence. From this mass of authentic information and of well-considered opinions we propose to make some extracts in elucidation of the subject of the present section.

From the information obtained the commissioners were enabled to draw up a schedule of the accidents which have happened to life and property on board steam vessels, within the period of the ten years preceding their report. This schedule, however, is to be considered as only an approximation to the real number of accidents, and a few of them occurred anterior to that period, but were mentioned by one or more of their correspondents.

The following is a numerical abstract of the schedule.

ABSTRACT OF NINETY-TWO ACCIDENTS.		
Vessels.		Ascertained Number of Lives lost.
40	Wrecked, foundered, or in imminent peril . . . .	308
23	Explosions of boilers . . . . .	77
17	Fires from various causes . . . . .	2
12	Collisions . . . . .	66
92	Computed number of persons lost on board the Erin, Frolic, and Superb . . . . .	120
	From Watermen's and Coroners' lists, in the Thames, exclusive of the above, during the last three years	40
	From a list obtained in Scotland, exclusive of the above, being accidents in the Clyde, during the last ten years . . . . .	21
		634
<p>The greatest ascertained number of lives lost at any one time, occurred by the wreck of the <i>Rothsay Castle</i>, when . . . . . 119 persons perished.</p> <p>The greatest number, at any one time, from collision . . . . . 62    "</p> <p>The greatest number, at any one time, from explosion . . . . . 24    "</p> <p>The greatest number, at any one time, from fire . . . . . 2       "</p>		

The following information and suggestion were derived from the evidence of Mr. J. C. Shaw, engineer and marine manager to the City of Dublin Steam Packet Company, Liverpool:—

No accidents have ever occurred in any of the Company's vessels from explosion, or rending of boilers. They construct and repair their own boilers, and prefer the cylindrical shape, with the internal flues of similar form. The boilers are all separate, each containing its own water, and the steam-pipes have separate valves to shut off the communication with the other boilers. The advantage of this plan is forcibly evinced in the case of the collision between the *Thames* and the *Shannon*. *The Thames must have gone down had the water in the different boilers not been distinct.*

The engines and boilers of steamers are certainly not overhauled and repaired so frequently as they should be. Experience has shown to the Company the value of a frequent and minute system of overhauling and repairing. The arrival of any one of their vessels is instantly notified at the office, both at Liverpool and Dublin; the foreman of the boiler makers, and the master engineer, immediately go on board, and are required within two hours to make a report in writing of the actual state of the engines, boilers, and all their apparatus, by filling up



printed forms prepared for each. The hull is inspected by a shipwright. Each vessel is placed on the gridiron at least once in every three months, merely to sight her bottom. The head fireman, having extra wages, is fined in the event of his not pointing out even if a rivet-head has sprung, or any other defect in his boiler during his last voyage.

The safety-valves in all their vessels are so arranged that the engineer can raise them to ease his boiler, but cannot load them beyond the assigned pressure: eight pounds per square inch is the highest pressure employed in their new cylindrical boilers. Vacuum valves, glass water-gauges, and a mercurial pressure gauge, fitted to all the boilers. The blowing-off and feed-cocks are of brass. In making new engines, they are also subject to a written detailed specification.

The Company's vessels are all constructed to a specification settled with Messrs. W. & J. Wilson, their builders; they are all much more substantial than the scantling required by Lloyd's Rules; they now build no vessels without iron water-tight bulk-heads. In the event of purchasing hulls built in other ports, they have them all in the graving-dock to be minutely examined, and such additional fastenings are added as are required to bring them up to their standard of strength.

The combustion of the coals has not unfrequently arisen in steamers from carelessness in dropping tow or waste among them, and leaving them there; and also from spontaneous ignition. The Company's boilers do not touch the skin of the vessel by many inches. The skin, or inside planking, is lined with sheet lead throughout the wake, or vicinity of the boilers; and the lead is covered over with thin sheet-iron. The addition of the lead is a most important feature, as it prevents charring. The boilers are all covered with dry hair-felt, and between them and the deck is a wrought-iron ceiling, resting on cast-iron beams. The coals are stowed in the space between the iron ceiling and the deck, with as much safety as in the iron coal-boxes. On the arrival of every vessel, a gang of coal-trimmers enter her and sweep down every atom of coal into the bunkers, for which we pay 5s. each trip, on the production of a certificate from the commander, that the work is done. By taking the duty of those on board, attention is secured to this important work; thus the old and often powdered coal gets burnt up first, and any defect in the ceiling-plates is at the same time discovered and remedied. A great saving of heat results from this complete covering, and the boiler tops are saved from the corrosion which used to take place when wet coals were stored upon them, or from rain or spray affecting them.

Boilers after being in use four years should be surveyed very frequently. After five years running, the boilers, timbers in their wake, deck-beams and ceilings, all require looking to, lest they might be injured; the middle of the vessel, which should be the strongest, becomes the weakest, after so long a period of working, in consequence of the skin being charred from constant heat. No steamer should have a license to ply which was not furnished with at least one valve inaccessible to the engineer or passengers, with a glass water-gauge to each boiler, and a mercurial pressure gauge, and always in order. The machinery should be inspected and certified by a competent, disinterested engineer, unconnected with any marine engine manufactory.

#### COPIES OF ORIGINAL REPORTS.

*City of Dublin Steam Co's. Works, North Wall.*

*Mr. J. C. Shaw.*

*Dublin, 22 Jans. 1859.*

*A Report of the state of the "Royal Adelaide" Boilers, this day, on her arrival from Belfast.*

*And find them in good order.*

*J. Marr.*

*James Powell, Foreman.*

*City of Dublin Steam Cys. Works, North Wall.*

*Mr. J. C. Shaw.*

*Dublin, 22<sup>nd</sup> Jany. 1839.*

*A Report of the state of the "Royal Adelaide" Engines, this day, on her arrival from Belfast.*

*And find them in working condition.*

*J. Marr.*

*A. Clegg, Foreman.*

*City of Dublin Steam Cys. Works, North Wall.*

*Mr. J. C. Shaw.*

*Dublin, 24<sup>th</sup> Jany. 1839.*

*A Report of the state of the "Duke of Cambridge" Engines, this day, on her arrival from London.*

*Two furnaces want repairing, and coal-bunkers will not do, which will take about two days.*

*J. Marr.*

*James Powell, Foreman.*

*City of Dublin Steam Cys. Works, Clarence Dock.*

*Liverpool, 25<sup>th</sup> Jany. 1839.*

*A Report of the state of the "Queen Victoria" Hull, this day, on her arrival from Dublin.*

*In want of a new piece of rubber on the larboard side.*

*To Mr. J. C. Shaw.*

*Jas. M'Arde, Foreman.*

The report states "that boilers are very frequently continued in use till they become dangerously thin; and that they are frequently deficient in safety apparatus is a fact, not only evidenced by the Table of Explosions, and instances given, but attested by a large majority of our correspondents. We were shown several in the yards of engine and boiler-makers, which (to use their own expression) 'might be walked through;' indeed, the hand might be pushed through some boilers which we examined, but recently taken out of steam boats. Mr. Shaw states, 'that the boilers of the *Fingal*, in 1835, were so weak that they had to be shored between the decks and the tops of them, which expanded and contracted like a pair of bellows.' Captain Bain writes that 'he has frequently had occasion, sometimes under very trying circumstances, to stop rents in boilers by temporary expedients; that he has witnessed it in other vessels, and has seen boilers worked till they were as thin as paper.'

"Some boilers, in actual use, are only kept tight by the deposit of mud, concretions of salt and sand, &c. between the flues; these obstructions to the passage of heat are not removed, as the metal of the boilers would give way, and they must then, necessarily, undergo repair, which is delayed till they will no longer hold together, or till ruptures occur, and have produced mischief.

"The explosion of deteriorated boilers is not the greatest danger to be apprehended from steamers so ill provided. Under the head of wrecks and foundering, the calamitous consequences of boilers failing at sea are still more fearfully exemplified.

"Great additional safety is obtained by employing several boilers, distinct from each other, rather than one only, or two boilers connected together; many dangers are avoided by this method. Independently of the obvious security arising from the means thus afforded of *shutting off* a disabled boiler,

and even of repairing it, whilst the motion of the engines is continued by the others, this arrangement possesses many other advantages, and cannot be too strongly recommended for general adoption.

"Several wrecks have been referred to by our correspondents, which might have been averted, had the paddle-wheels been furnished with *disengaging apparatus*, which is effected too slowly and clumsily by removing the float,—an operation also difficult of accomplishment in tempestuous weather."

The primary causes of nearly all the accidents which occur to life and property on board steam-vessels, may be classed as follows:—

#### *Of Wrecks, Foundering, or imminent peril of the same.*

*Causes.*—Defectiveness of hull, boilers and engines, cables and anchors, crankness.

#### *Of Explosions.*

*Causes.*—Ignorance, carelessness, recklessness, and drunkenness of engine-men. Bad construction or insufficiency of safety-valves. Inattention to, or want of, proper apparatus to denote the level of water and pressure of steam in boilers. Malformation of boilers to sustain pressure. Working old boilers too long, and at too great pressure. Bad materials, and bad workmanship of boilers.

#### *Of Fires.*

*Causes.*—Carelessness, and want of cleanliness. Bad construction of coal receptacles. Stowing coals on the boilers, and against the undefended sides of the vessel. Placing boilers too near the decks and sides of the vessel. Defective state of the boilers. Want of fire-extinguishing apparatus.

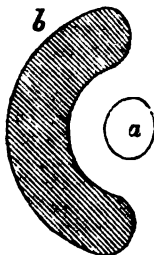
#### *Of Collisions.*

*Causes.*—Want of an universal code of night signals. Want of a defined and compulsory "rule of the road." Racing. Carelessness, or neglect of look-out.

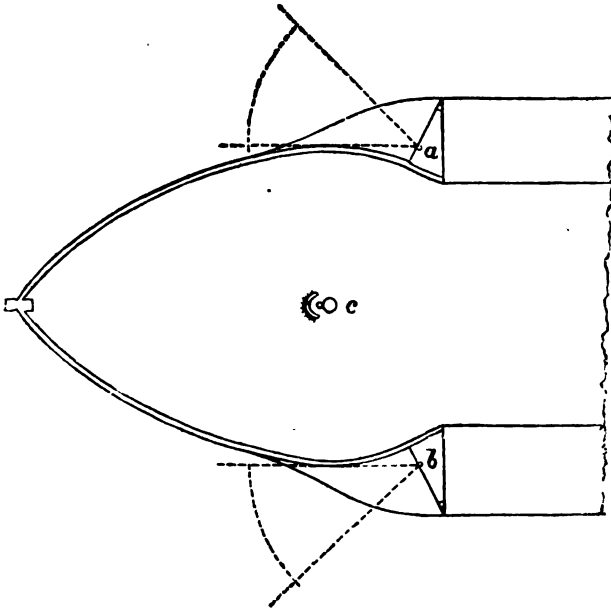
On this head the Commissioners observe:—"Collisions between steam-vessels, and between them and other craft, occur so frequently in crowded waters,—they are often so fatal to life, and so generally attended with litigation and expense in repairing damage, that the want of a law to diminish the evil is the subject of complaint by nearly all our correspondents. Collisions occur both by day and by night, at sea as well as in rivers. They commonly arise from the absence of a universal understanding as to 'the rule of the road' to be observed by vessels in meeting and passing each other, and from the absence of a universal system of *night-lights*, or signals."

Mr. Shaw introduced a system of night-signals in that Company's vessels in 1834, which has since been adopted by her Majesty's packets at Liverpool, and in other steamers. This system consists of one *white* light at the foremost head, one *white* light on the *starboard* paddle-box, and one *red* light on the *larboard* paddle-box. These are all resplendent and powerful lights. The mast-head light is transmitted through a large solid glass lens, so shaped and disposed that the light ceases to be visible abaft the beam. The marginal cut represents a horizontal section of this light; *a* being the light, and *b* the solid lens. The starboard paddle-box light is also transmitted through a solid glass lens; the larboard light through a hollow glass lens, containing a red mineral solution. These are placed in houses attached to the paddle boxes, and the rays are projected at an angle of about 35 degrees with the keel, so as not to dazzle the look-out men on the fore-castle. They are visible at great distances. A diagram of the system is given in the cut on the next page, in which *a* is the starboard light (bright), *b* the larboard light (coloured), and *c* the mast-head light.

To secure the adoption of what may from time to time be proved as the most eligible methods of building and fastening a steam-



vessel, the first essential is, that a *written detailed specification* be prepared as the basis of every contract, in which the dimensions, principle of construction, modes, extent, and size of the several fastenings be stated. The specification



should also be accompanied by working drawings of the mode in which such parts are to be executed as cannot be given by mere description.

*Outline of proposed Legislative Regulations prepared by the Commissioners:—*

1. That a Board be appointed in connexion with, and under the president of the Board of Trade, whose business it shall be to register and classify all vessels navigated by steam, built or building: the register to record detailed specifications of hull and machinery, periodical surveys to be made upon them, and particulars of all disasters and accidents which happen to, or may be occasioned by steam vessels.

That the Board be authorized to appoint local or district surveyors to inspect and report upon the condition of steamers; that, on such report being satisfactory, the Board shall grant licenses to the owners of steam vessels to ply; that, if unsatisfactory, they shall withhold such license, as far as relates to the conveyance of passengers. Penalty for plying without license.

That the Board be empowered to investigate personally, or otherwise, the nature and causes of accidents, to examine witnesses on oath, and call for the production of papers.

That the Board be required to make an annual report to parliament of its proceedings, of the state and progress of the mercantile steam marine, and of the disasters which may have been sustained. That the records be public on the payment of a reasonable fee.

That the Board be empowered to frame and issue general instructions for the guidance of the local or district surveyors; also to publish an abstract of the law and regulations, with authority to require such abstract to be placed in a conspicuous part of the vessel; under penalties on neglect.

2. That the surveyors of hull and machinery be paid for their surveys by the owners of the vessels according to a fixed scale, as is the practice for Lloyd's Register: that they shall forward their reports to the Board, which, in the event of the owner or owners objecting to the repairs required in order to entitle the vessel to a passenger license, shall (if the objection regard the hull) call in one or two of the principal ship-builders of the port or district, unconnected with the work of such repairs, to survey the vessel, in conjunction with the official surveyors, and report especially thereon.

Should the decision of the Board be objected to, on the report of the surveyor (if the objection regard the machinery), it shall call in the aid of one or more engineers to report in conjunction with such official surveyor.

Special surveys to be paid for by the owner, or owners, of the vessel, according to a fixed scale.

The first survey of the hull of a new vessel to be made during its construction, and a specification of it transmitted to the Board, as is now done by the surveyors of Lloyd's to the committee.

A survey of the hull to be made during each of the two first years, and a survey every six months subsequently. All steamers to be docked, benched, or laid on the gridiron (as circumstances permit), and surveyed, after sustaining any injury by taking the ground, or otherwise, under penalty.

The first survey of the boilers, engines, and machinery, to be made whilst they are being fixed in the vessel, and the requisite details of them to be reported to the Board.

Boilers, engines, and machinery, to be surveyed every six months after the first year, and all serious accidents to be reported.

The surveyors to report on the fitness of a vessel, whether as a sea-going or river-steamer.

3. License to express whether it be granted for cargo only, for towing vessels, for the conveyance of passengers, or for these purposes combined; also, whether the vessel be intended to ply as a river or sea-going steamer.

License to ply with passengers to be granted or withheld as aforesaid; a duplicate of which, or certificate to the same effect, signed by the Board, to be exhibited in the cabin, or other conspicuous part of the vessel. All public advertisements of steamers to state whether licensed to carry passengers or not.

An annual charge for each license to be made on all steam-vessels, varying according to a scale of size and capacity; such charge to be in no case less than £1, nor exceeding £5.

4. That the surveyor shall ascertain that the safety-valves be sufficient to pass all the steam which the boilers can generate in their ordinary state of work, at the pressure determined by the weight on the valves; the maximum of which pressure shall be fixed by the maker of the engines or boilers, and the valves be loaded accordingly.

5. That, after an assigned period, no passenger license be granted to any vessel having safety-valves whose spindles, or levers, are exposed on deck, or capable of being loaded externally, unless satisfactorily protected. Penalty on engineers, masters, or others, for loading valves beyond the weight ascertained by the surveyor, and regulated as above.

6. That in all new steamers, and after an assigned period in all steamers now afloat, glass water-gauges, and mercurial pressure gauges, shall be required to be fitted to the boilers, to entitle the vessels to a license to ply with passengers.

No perfect mechanical substitute can be found for *care* in the management of the steam-engine at sea or on land; nor do we think that the use of the fusible discs, enforced by the French laws, would be productive of additional security; nor, indeed, that any complexity of apparatus attached to boilers would contribute to the attainment of that object.

Apparatus, however, for indicating the level of water and pressure of steam in boilers, is essential to their safe and economical management, and is of far greater import to the boilers of marine than of land engines; accidents to the former, or failure in their supply of steam, being attended with peculiar

dangers and disasters at sea, from which land boilers are exempt. Yet it is a fact, accounted for, perhaps, by the circumstance of steam-vessels being owned and managed, generally, by persons unacquainted with the nature of the steam engine, that these simple instruments are much more rarely to be found attached to marine than to land boilers, which latter are usually under the direction of parties of mechanical education or knowledge.

7. That, in the event of the surveyor having information that any boiler be deteriorated in strength, or unsafe at its working pressure, in the interval of his periodical surveys, he shall be empowered by the Board, on his representation, to examine it; and in the event of the boiler proving faulty, the Board shall suspend the passenger license, until satisfied of the safety of such boiler.

8. That no steam vessel be permitted to ply which is not furnished with a binnacle and compass in good order.

9. That, after an assigned period, no sea-going steam vessel, which carries coals on the tops or about the sides of the boilers, shall be entitled to a passenger license; unless the boilers be protected by a shell of metal, or other sufficient security.

10. All river steamers to carry one effective boat, coasting and channel steamers two or three boats, according to their size, and ocean steam-ships four boats, as a minimum.

The surveyors to ascertain that these boats be kept in serviceable condition, and ready for use on emergency.

11. All steamers to be provided with sufficient hoses, to convey water to any part of the vessel, with a serviceable outfit of water-buckets; and a moveable fire-engine to be carried in all coasting, channel, and ocean-going steamers.

The proposed system of registration should include a classification of steamers; and as the character to which each vessel would be entitled in its class would depend on its general state of efficiency, we are disposed to think that many other important requisites for attaining the utmost practicable degree of security, would gradually be adopted by owners without compulsion; such as water-tight bulk-heads in new vessels; powerful extinguishing pumps, worked by the engines; connexion of the condensers with the bilge-water; disengaging apparatus for the paddle-wheels; heavier and more effective ground tackling, &c. The publication of accidents, and of their causes, would also warn steam vessel owners, commanders, and engineers, and instruct them how to guard against disasters.

In framing these recommendations, our object has been to suggest practical means for further securing public safety, without inflicting vexatious rules on steam vessel owners; we believe that their adoption would tend materially to promote, and in no respect to cripple, the progress of navigation by steam. We are confirmed in these views by finding them so much in accordance with the majority of opinions expressed in the appendix: and they correspond with several of the regulations enacted by foreign states. They are, however, much less stringent in their nature than those proposed by many of our correspondents; and we consider them much less onerous, and more suitable to the character of the British steam-marine, than the laws of other countries.

In order to diminish the frequency and danger of collisions, and being convinced of the necessity for establishing a definite "rule of the road," and a uniform system of signals, for the government of steam vessels, we should have introduced into the foregoing outline distinct provisions on the subject, had it not been that a measure of this kind has been advised in the report of the "Commissioners appointed to inquire into the laws and regulations relating to the pilotage of the United Kingdom," (p. 161,) to be incorporated in a new Pilot Act. Referring, however, to the tenor of our instructions as to "the nature of the accidents in steam vessels," and to "the means of preventing them," and on a review of the valuable information supplied to us on this head, we cannot avoid recommending the adoption of a system which has for so many years been found practically efficient—against which no objections have

hitherto been urged—and which has met the concurrence of so numerous a body of steam-navigators. The system we advise is—

1. As to the “rule of the road,” that steam-vessels approaching and passing each other, should *starboard* their helms, with the view of keeping on the starboard side of each other respectively as far as practicable.

2. As to night signals,—the want of an uniform and sufficient system of lights has been so fruitful a source of collision and injury, we recommend a system similar to that now practised by a numerous class of commanders of private steamers (described p. 48), and which has been substantively approved of and adopted by the commanders of her Majesty’s steam-packets at Liverpool: viz., that in all sea-going steam vessels, there be “a *white* light at the foremast head, visible in clear weather from eight to ten miles; a *white* light attached to the fore part of the *starboard* paddle-box, which can be seen six miles in clear weather; and a third light, which is *red*, attached to the fore part of the *larboard* paddle-box, visible about three miles. The three lights can only be seen at one and the same time when right a-head, or nearly so; in any other position, before the beam, two only are visible, and their colours define the position of the vessel.”

3. That the obligation to carry some powerful steam-whistle, bell, or gong, be part of the proposed law as regards steam vessels; also, that their rate through the water be defined, during fog and thick weather, in crowded waters, whether plying by day or night.

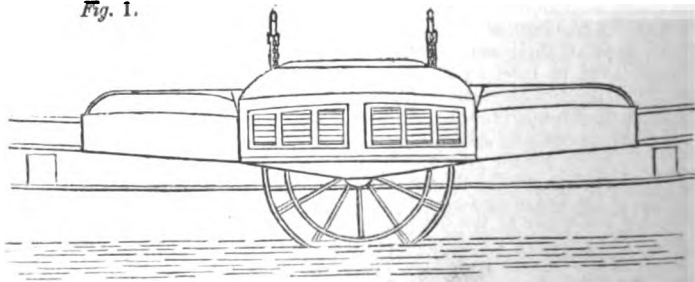
It is also obvious that some regulations are essential to determine the nature and enforce the carrying of lights in river-steamers, sailing-vessels, and vessels at anchor.

Owing to the number of passengers frequently embarked on board of steam-vessels, it becomes difficult to provide the means of safety for all in the event of an accident which may render it necessary to abandon the vessel. A plan has recently been proposed by Captain George Smith, R.N., which goes far to meet this difficulty, and is calculated to be of essential service on such trying occasions. We extract the following account of this invention from Captain Smith’s letter to Messrs. Pringle and Parke.

“It is universally admitted, that steam vessels are very deficient in boats; so much so, that, when a steam vessel is lost, if the lives of the passengers and crew be not sacrificed, it may be considered an especial interposition of Providence.

“This deficiency, and the difficulty in steam vessels of carrying boats on deck, and in getting them in or out, have led me to turn my attention to the subject; the result has been the invention described in the accompanying drawing, which invention my Lords Commissioners of the Admiralty have been pleased to try on board her Majesty’s steam vessel *Carron*, (a vessel of

Fig. 1.



between 200 and 300 tons burden.) The upper section of her paddle-wheel is covered by a life-boat (see Fig. 1.) twenty-five feet long and nine feet beam, having four air-tight cases, which may be removed if required on particular occasions. This life-boat is capable of containing between forty and fifty

persons. When in her place over the paddle-wheel, the midship thwarts are unshipped, which admits of the wheel revolving within about six inches of her keelson.

"The boat lies bottom upwards on two iron davits, having hinges, which enable her to be turned over and lowered down by six men in two or three minutes. A boat of similar capacity could not be got out, if stowed in the usual position

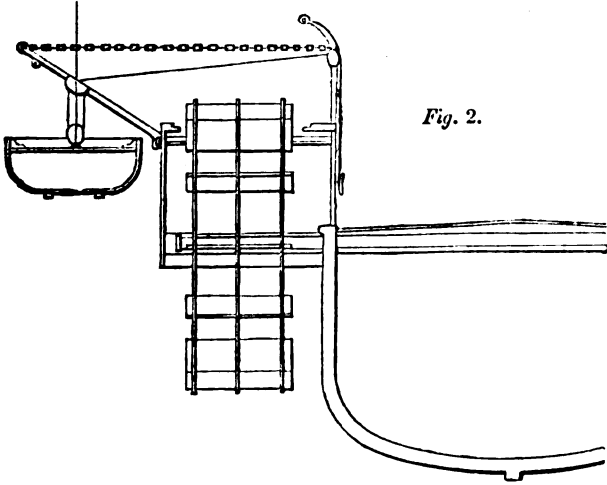


Fig. 2.

on deck, under twenty minutes by the whole crew, and in case of fire, probably not at all."

Fig. 2 is a transverse section of the vessel, showing the boat on one side as turned over, and ready to be lowered down.

"It is proposed, that steam-vessels should have one large boat over each paddle-wheel; in the most powerful vessels they may be thirty feet in length, with above nine feet beam.

"Vessels fitted with boats on this plan present less resistance to the wind and atmosphere in sailing and steaming, and their appearance is considerably improved. The upper float-boards can be got at with ease when requisite, by raising the boat a little on her davits. If thought requisite to add to the number of boats, the cabins before and abaft the paddle-wheels may be roofed in by smaller boats." (As shown in Fig. 1.)

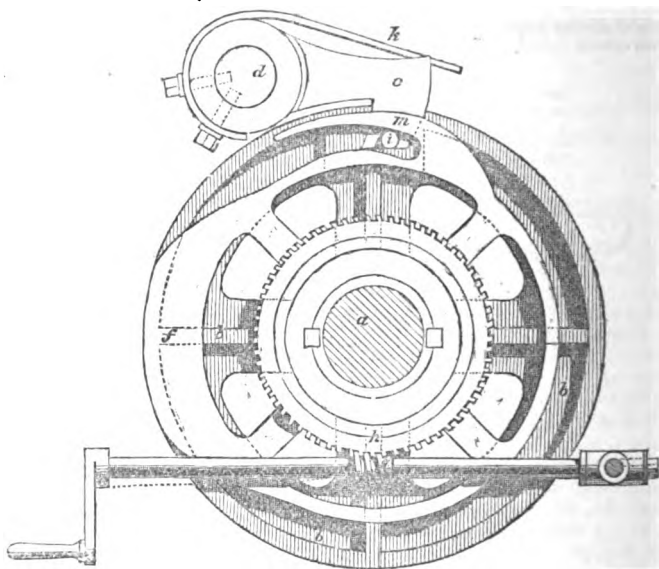
It is, on many accounts, extremely desirable that steamers should be furnished with the means of instantaneously disconnecting the paddle-wheels from the engines, so as to leave each free to revolve independently of the other; and many instances might be cited, wherein vessels have been lost for want of this provision. Thus, in the melancholy case of the *Forfarshire*, the vessel, in a heavy gale of wind, with her engines broken down, was suddenly discovered to be within a short distance of rocks; sail was instantly set, and an attempt was made to wear her, but, owing to the resistance of the paddle-wheels, which were still connected to the engines, she could not be forced through the water in time, but drove on shore, and was totally wrecked, with a loss of nearly fifty lives. Again, the *Don Juan*, in fine weather, struck on a rock, and sprung a serious leak, but which might have been got under by the pumps fitted to the engines, but the inner wheel being fixed on the rock, the engines could not work, and the vessel was lost.

Many plans have recently been brought forward for supplying the desideratum. The following cut represents one, for which Mr. Murdoch obtained a patent in 1839. It will be seen that it admits of great solidity of construction,



can be readily adapted to engines of every form, and that its action is instantaneous.

To the paddle shaft *a* is attached, in lieu of the ordinary crank, a cylindrical drum *b*, having a gap or notch in its circumference into which a pall or drag-



link *c*, suspended from the end of the crank pin *d*, falls, and this forms a connexion between the crank and the drum, so that the paddle shaft *a* and the engine shaft *e* revolve together. When it is required to disconnect them, the cam *f*, which is loose upon the boss of the drum, is turned by means of the worm *g* and worm-wheel *h*, and, pressing against the under side of the stud *i*, which projects from the side of the drag-link, it gradually releases the latter from the notch in the drum, and a portion of the cam being concentric with the drum, and of the same diameter, covers the aperture and prevents the link from falling into it during the revolutions of either shaft. *k* is a spring to counteract the centrifugal force of the link, and cause it to fall into the notch when desired in any position of the drum; and *m* is a horn projecting from the cam, which presses upon the stud *i*, and retains the link firmly in the notch.

Since the foregoing part of this treatise has been in the press, the recommendations contained in the report of the commissioners have been partially adopted; an Act of Parliament having been passed for the regulation of steam-vessels, of which the following are the principal provisions:—

1. All steam-vessels built of iron of 100 tons burthen or upwards, the building of which shall have been commenced after the passing of the Act, are to be divided by transverse water-tight partitions, so that the fore part of the vessel shall be separated from the engine-room by one of such partitions, and so that the after part of such vessel shall be separated from the engine-room by another of such partitions.

2. From and after the first day of January, 1847, no vessel, the tonnage of which shall be 100 tons or upwards, shall proceed to sea, from any port whatsoever, unless it shall be provided with boats, duly supplied with all requisites for their use, and not being fewer in number, nor less in their dimensions, than the number and dimensions set opposite to the limits of dimensions in the following table, provided that the said limit of dimensions be not considered applicable to vessels engaged in the whale fishery:—

TONNAGE OF VESSEL.	Number of boats.	Long boat, launch, or pinnace.		Other boats.					
		length	breadth	length	breadth	length	breadth	length	breadth
		feet.	ft. in.	feet.	ft. in.	feet.	ft. in.	feet.	ft. in.
850 and upwards .....	4	26	8 0	24	7 0	22	6 6	16	5 6
650 to 850.....	4	24	7 0	22	6 6	18	5 6	16	5 6
350 to 650.....	3	20	6 6	18	5 6	...	...	14	5 0
200 to 350 inclusive .....	2	18	6 0	...	...	...	...	14	5 0
100 to 200.....	2	...	...	16	5 6	and a punt or small boat.			

and that no vessel carrying more than ten passengers shall proceed to sea on any voyage, unless, in addition to the boats hereinbefore required, it shall also be provided with a boat fitted up as a life-boat, with all requisites for its use, together with two life buoys.

3. Every steamer the building of which shall be commenced after the passing of the Act, and which shall proceed to sea with a passenger, shall, in addition to the boat specified in the foregoing table, and in lieu of a boat fitted up as a life-boat, be provided either with such boats as are usually called paddle-box boats, or with such other boats as may be directed in lieu thereof by the Commissioners of the Admiralty.

4. That no steam vessel of 100 tons burden or upwards shall proceed to sea unless it shall be provided with a hose, for the purpose of extinguishing fire, capable of being connected with the engines of the vessel.

5. If any such steam vessel as aforesaid proceed to sea without being provided with such hose as aforesaid, or, being an iron steam vessel, without being so divided as aforesaid, or if any steam or other vessel of 100 tons burden or upwards proceed to sea without being so provided with boats as aforesaid, or if any of such boats be lost or rendered useless in the course of the voyage, through the wilful fault or negligence of the owner or master, or if, in case of any of such boats being accidentally lost or injured in the course of the voyage, the master or other person having charge of the vessel wilfully neglect to replace or repair the same on the first convenient opportunity, then and in every case where the owner shall appear to be in fault, he shall forfeit a sum not exceeding 100*l.*, and in every case where the master or other person having charge of the vessel shall appear to be in fault he shall forfeit a sum not exceeding 50*l.*

6. No officer of customs to clear out any such steam vessel as aforesaid for any voyage to parts beyond the seas without being provided with such hose as aforesaid, or, being an iron steam vessel, without being so divided as aforesaid, nor to clear out any steam or other vessel of 100 tons burthen or upwards, for any voyage to parts beyond the seas, unless the same be provided with such boats as hereinbefore are required.

7. Every steam vessel when meeting or passing any other steam vessel shall pass as far as may be safe on the port side of such other vessel, and every steam vessel navigating any river or narrow channel shall keep as far as is practicable to that side of the fairway or midchannel of such river or channel which lies on the starboard side of such vessel, due regard being had to the tide; and the master, or other person having the charge of any such steam vessel, and neglecting to observe the regulations, or either of them, shall for each and every instance of neglect forfeit and pay a sum not exceeding 50*l.*

8. On or before the 30th of April and the 31st day of October in every year, the owners of every steam vessel shall transmit to the Lords of the Committee of Privy Council for Trade the two following declarations in writing, (that is to say)—

*First.* A declaration of the sufficiency and good condition of the hull of such steamer, under the hand of a shipwright-surveyor to be approved by the Lords of the said Committee.

*Second.* A declaration of the sufficiency and good condition of the machinery of such steam vessel, under the hand of an engineer to be approved by the Lords of the said Committee; such declarations bearing date of some day in the said months of April or October respectively.

And the Lords of the said Committee shall register such declarations, and shall transmit to the owners of such steam vessels respectively certificates, under the hand of one of the secretaries or assistant-secretaries of the said Committee, of the registry of such declarations.

9. If any steam vessel proceed to sea with passengers, the owner whereof has not duly transmitted to the Lords of the said Committee such declarations, and received from the Lords of the said Committee such certificates of the registry of such declarations as herein before is mentioned, the owner of such steam vessel shall forfeit a sum not exceeding 100*l.*

10. Whenever any steam vessel shall have sustained or caused any serious accident, occasioning loss of life or property, or received any material damage affecting her seaworthiness, either in her hull or her engine, by grinding or by collision with any other vessel, or by any other means, the master or other person having the charge of such vessel shall, as soon as conveniently may be, transmit through the post office, by letter addressed to the Lords of the Committee of Privy Council for Trade, and signed by such master or other person, a report of such accident or damage, and the probable occasion thereof, stating therein the name of the vessel, the port to which she belongs, and the place where she is, in order that the Lords of the said Committee may, if they think fit, investigate the matter; and should the owner or owners of any steam vessel from her non-appearance or otherwise have reason to apprehend that such steam vessel is wholly lost, he or they shall, as soon as conveniently may be, in like manner send notice thereof to the Lords of the said Committee; and every owner, master, or such other person as aforesaid, who shall neglect to send such notice as hereby is required within a reasonable time after any such accident shall have happened, shall for every such offence forfeit and pay a sum not exceeding 50*l.*

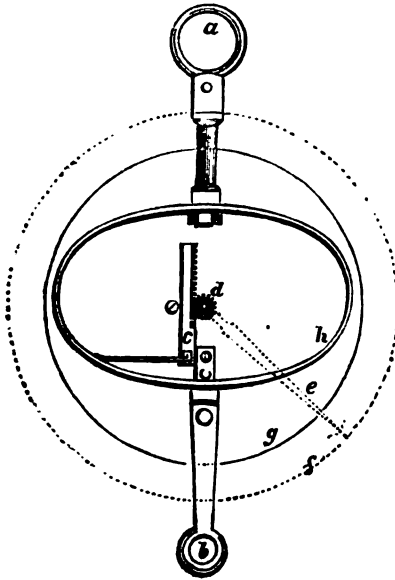
11. Whenever any steam vessel shall have sustained or caused any serious accident occasioning loss of life or property, or received any material damage affecting her seaworthiness either in her hull or her engine, by grounding or by collision with any other vessel, or by any other means, it shall be lawful for the Lords of the said Committee to appoint any proper person or persons as inspector or inspectors to inquire into and report upon such accident; and it shall be lawful for every person so authorized, at all reasonable times, upon producing his authority if required, to go on board and inspect any such steam vessel and the machinery thereof, and every part thereof respectively, not detaining or delaying the vessel from proceeding on her voyage, and to make such inquiries as to the nature, circumstances, and causes of such accident as he or they may think fit.

12. That nothing in this Act shall extend to any of Her Majesty's ships of war, nor to any vessel not being a British registered vessel.

**STEEL.** A peculiar combination of carbon with iron. It is chiefly used for edge tools, and other sharp cutting instruments, where great hardness is required; and from the fine polish of which it is susceptible, its applications to ornamental as well as useful purposes are as obvious as they are well known. See **IRON**.

**STEELYARD.** A machine for ascertaining the weights of bodies, usually denominated the Roman balance. It consists of a lever of unequal arms, suspended horizontally; to the shorter of the two arms is suspended the article to be weighed, and on the longer arm a weight is made to traverse, until the beam rests in a horizontal position; the position of the traversing weight indicating the weight of the article, which is engraved on the beam where the weight stops. See the articles **BALANCE** and **LEVER**. There is, however, another kind of steelyards in extensive use for domestic and other purposes, wherein great nicety in weighing is not appreciated. They are usually called "pocket steelyards," and

are thus constructed:—In the centre of a distended spiral spring of many coils, is a metallic bar, on which are marked the divisions of the scale, according to the amount of force or weight in pounds, requisite to compress the spring to any point represented. To one end of the bar is rivetted a plate, to press upon the spring, which are both in a cylindrical metal case; the other end of the bar passes freely through a hole in the bottom flat end of the case, where it is connected to a hook, on which the article or goods to be weighed are hung; and according to their actual weight the bar, by compressing the spring, is externally protruded, showing by the figure on the scale the weight of substance suspended. A great variety of machines for indicating weight and pressure by the elastic resistance of springs have been invented, and several have been described in the course of this work, (see the articles DYNAMOMETER, CABLE, and others,) and we shall here add one more, which has been brought into very extensive use by the diligence and skill of Mr. Mariott, of London. The machine we allude to is denominated Mariott's Patent Weighing Machine. It is an invention of 150 years standing, and the improvements made by Mr. Mariott relate to some minutiae, which, though of a subordinate, are not of a useless character. The annexed diagram is illustrative of the construction of the internal part. *a* is the ring by which the machine is suspended: to the stem proceeding from the ring the uppermost side of a strong elliptical steel spring is made fast by a nut and screw; at *b* is suspended the scale, or other receptacle to



hold the goods to be weighed; the stem of this is secured to the lowermost side of the spring, and likewise at its upper extremity to a vertical rack *c*, which is drawn downwards as the elasticity of the spring is operated upon by the weight; the descent of the rack turns a small toothed pinion *d*, on the axis of which is fixed a hand *e*, that points out upon the graduated circle *f*, the amount of the force or weight applied. The inner circle *g*, shows the periphery of the circular box, which encloses the parts delineated within it. The periphery of the front plate and the index are shown in dotted lines, as they are not supposed to be seen in this view of the apparatus. This machine is extremely convenient and portable, it requires no weight, may be hung up any where, and is sufficiently accurate for the generality of purposes, where inaccuracies to the extent of a few small fractional parts are of no moment.

**STILL.** The name of the principal vessel in which distillation is conducted. See a great variety of them under the heads ALCOHOL, DISTILLATION, &c.

**STIPPLING.** A mode of engraving on copper by means of dots, as contradistinguished from a course of continued lines. The term is likewise applied to the mode adopted by some artists in drawing, of putting in the tints and shadows of black lead or crayons, by means of the end of a piece of coiled paper, charged with the pigment, with which it is stippled or stamped on to the surface of the paper. Good artists generally despise this process; and we are of opinion that none but good artists should attempt to practise it, on account of its wretched spiritless appearance, if not very ably performed.

**STOCKS.** A frame erected on the shore of a river, or of the sea, and in the large establishments in the inside of docks, for the purpose of building

ships. It generally consists of a number of solid wooden blocks, ranged parallel to each other at convenient distances upon a very firm foundation, and with a gradual declivity towards the water.

**STRAND.** One of the twists or divisions of which a rope is composed; also the name applied to any sea-beach, or shore, that slopes gradually down to the water's edge

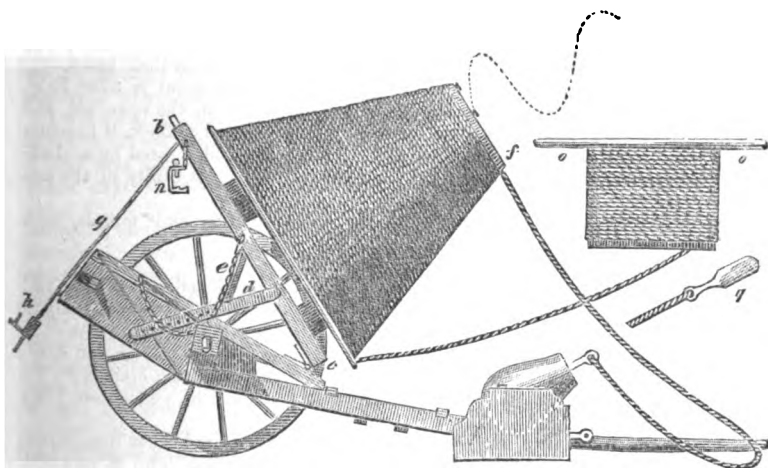
**STRANDED**, in *sea affairs*, a term, which, when applied to a rope, signifies that one, at least, of its strands is broken; but when applied to a ship, or vessel, it means that she has run on a rock or shoal, and been either rendered useless, or entirely dashed to pieces. The considerable loss every year of valuable lives, by shipwreck, on the British shores, had early attracted the notice of the Society of Arts, and premiums were offered for the discovery of effectual means of diminishing the frequency of these distressing calamities. In the year 1791, Mr. J. Bell, serjeant of artillery, proposed the projection of an eight-inch shell, loaded with lead, and having a light rope attached to it. The shell being discharged from a small mortar on the deck of a stranded ship, would perform a range of about 200 yards, carrying the rope with it, and would bury itself in the sand on the shore, so as to form a communication with the land, by means of which boats, or rafts, might be hauled through the surf, and thus greatly facilitate the probability of escape from the wreck. The objections to this plan consisted in the difficulty of prevailing on the owners of merchant ships to incur the expense, and on the masters to have the apparatus in constant readiness for use. Besides which, many cases would no doubt occur, in which, from the pitching of the vessel, and from the sea beating over her, it would be impossible to project the shot in the right direction, or even to discharge the mortar at all.

In 1808, Capt. G. W. Manby, of Yarmouth, effected considerable improvements on the original proposal of Mr. Bell. These consisted in stationing the apparatus on the shore, instead of having it on board the ship, as, indeed, had previously been proposed by Mr. Bell; thus enabling, in the first place, a single apparatus to be used in aid of every vessel that might be driven ashore, on a considerable line of coast. Secondly, enabling the persons intrusted with the apparatus to become familiar with it, and therefore prompt in its application. Thirdly, increasing the probability of success by having the power of placing the mortar in the most favourable position, with regard to the vessel, and of arranging the rope, so as to render it much less liable to entangle, and thereby to break, than if it were thrown from the deck of the stranded vessel. The great personal activity and exertions of Capt. Manby in this very interesting and meritorious undertaking, were liberally seconded by the government; and the result, that on the eastern part of Norfolk alone, where Capt. Manby has been stationed, *no less than 332 persons have been rescued* from 48 stranded vessels between 1808 and 1826. Capt. Manby's original method of coiling or faking the rope on the shore, was an operation that required to be very dexterously performed; was impracticable in some places from the inequalities of the ground; was liable to derangement from the wind; occupied much precious time after the arrival of the apparatus, and scarcely admitted of being performed at night. A great improvement was subsequently made by Capt. Manby, in having the ropes arranged in baskets, which allows of their being now conveyed in a state ready for immediate use, to any place where they may be wanted. Under the management of Capt. Manby, and his immediate assistants, the breaking of a rope, in consequence of its getting foul while running out, is a very rare occurrence. Other persons less accustomed to the business, and, perhaps, less dexterous, have, however, frequently failed; and it seems to be generally allowed by the associations on the coasts of Norfolk and Suffolk, for relief in cases of shipwreck, that some more certain mode of faking or coiling the rope would be an important improvement.

In 1823, Mr. Hase, of Saxethorp, in Norfolk, being employed to cast a brass mortar for one of Capt. Manby's apparatus stationed near Cromer, constructed a skeleton reel, or rather conical spindle, as an improvement on Capt. Manby's baskets. This reel was supported by an axis, which allowed of its being placed

at any required angle; and the rope being wound round it, was expected to be delivered more freely, and with less risk of breaking, than by the usual mode. Experiments made at Cromer confirmed the anticipations of the inventor, and the apparatus has now been in use for three years, and, apparently, has given much satisfaction.

Finally, Mr. Thorold has given to Mr. Hase's reel a stronger and more compact form, has both expedited and facilitated the coiling of the rope evenly upon it, and has placed the mortar and reel upon wheels, so that it may be transported expeditiously to any place where it is wanted. It is obvious, however, that by so doing, the expense of the whole apparatus is greatly increased; that it is now scarcely capable of being conveyed by hand, as Capt. Manby's, and even Mr. Hase's is; and that, therefore, situations may occur, to which it would be difficult, if not impossible, to bring it. The following figure presents a side elevation of the cart (with the near wheel off) and reel, and the mortar elevated



into a position for firing. The axis of the conical reel is fixed in the centre of a strong wooden cross, which is framed and secured by four bolts to the bars *b b*; these are hinged at *c* to the cart; *d* is a bar of iron with holes, serving as an elevator; it is screwed on to the frame *b*, and one of the holes being placed on a pin fixed in the cart's side, retains the reel at the required angle. Two chains *ee* are fixed on at each side of the cart, and to the frame *b b*, which retains it; while the reel is vertical, the elevator *d* catches the pin by its last hole. At *f* there is a movable ring and winch handle (not represented); *g* a guide bar, turning on pivots in the frame *b*, on which is a sliding box *h*, to be used in coiling the rope. Within the winch ring is a hook: a bend of the line being placed on this, the reel is turned once round, and the rope passed through the eye of the guide box *h*, properly constructed, and a pair of nippers (not shown). When the mortar is to be fired, the guide bar *g* is thrown back into the position represented, and the winch. The pressure of the guide bar being thus taken off, the elasticity of the cord causes it to rise a little, and throw off two or three of the upper coils; the next coil is kept in its place by one of the assistants laying his finger on it, and not withdrawing it until the moment of firing. The mortar is to be placed a few yards to leeward of the reel, with the line attached to the shot. A clamp *n* hangs from the frame *b*, by means of which the last coil of the rope is to be bound to the rim of the cone, in order

to secure it for travelling, the remainder of the line being on the frame &c. Another line, on a similar frame, is stowed in the tail of the cart; and in front of the axletree there is a locker for the shot, the peculiar form of which is shown by the separate figure *g*. The time required for winding the line, and firing the shot, is one minute and a half. Numerous certificates on the advantages of Mr. Thorold's apparatus, accompanied that gentleman's communication to the Society of Arts, who voted him the silver Vulcan medal:—a model of which invention is placed in the Society's Repository.

**SUBERIC ACID.** An acid obtained from cork; *suber* being the specific name of the cork-tree.

**SUBLIMATION.** An operation, by which volatile substances are collected and obtained. It is nearly allied to distillation, excepting that in the latter, the fluid parts only of bodies are raised, whereas, in sublimation, the solid and the dry are obtained. Flowers of sulphur are obtained in this way; and the soot in our chimneys is a familiar and perfect illustration of sublimation.

**SUCCINIC ACID.** An acid extracted from amber, by distillation.

**SUCKER.** A name given by plumbers to the bucket, piston, or rising valve of a pump: see **PUMP**.

**SULPHATES.** Definite compounds of sulphuric acid with the salifiable bases.

**SULPHITES.** Definite compounds of sulphurous acid with their bases.

**SULPHUR.** A simple inflammable body. Its fusing point is 220° Fahr. after which it begins to evaporate; at 560°, it takes fire in the open air, and burns with a pale blue flame: kept melted in an open vessel at 300°, it becomes of a red colour, thick, viscid, and plastic, like wax, and is used by seal engravers to take off impressions from their work. Its great utility in the arts is too well known to need specifying.

**SULPHURETS.** Combinations of the alkalic earths, and metals, with sulphur.

**SULPHURIC ACID:** see **ACID, SULPHURIC**.

**SUMACH.** A vegetable substance, extensively employed in tanning and dyeing. It consists of the young shoots of a shrub, that grows naturally in many parts of the Mediterranean; the shoots, after being dried, are reduced to powder in a mill, which adapts it to the immediate use of the tanner and dyer: it abounds in tannin and the gallic acid, strikes a deep and rich black with the salts of iron, and is eminently valuable in the arts alluded to, (which see.) and many others.

**SWIVEL.** A kind of ring or link of a chain, that is enabled to turn round, by jointing it to the next, by means of a pin or axis. The term of swivel is applied to a small cannon, provided with a similar kind of joint; and to very numerous purposes, *swivel-joints* are adapted and modified in a variety of ways too unimportant to describe.

**SWORD.** A long-bladed knife, fashioned in various ways, but all designed for mangling or destroying the human species.

**SYRINGE.** A simple hydraulic machine, employed to draw in and discharge fluids violently. It consists merely of a small tube, in which is fitted a piston or plunger, and having a small hole at the bottom of the tube, through which the liquid enters, when the plunger is drawn back, and charges the barrel. Then, by forcing the plunger forwards, the fluid is expelled with a violence proportioned to the velocity given to the plunger.

## T.

**TABBY.** The name of a rich kind of silk, which has undergone the operation of *tabbying*; which consists in passing between metallic rollers, the surfaces of which are variously engraven, producing thereby the device upon the stuff, by laying down the fibres in one part, and leaving them erect in the other, rendering them conspicuous by the difference of light and shade

**TABLES.** In *mathematics*, they are the results of calculations, systematically arranged, for the convenience of ready application. They also serve the useful purposes of testing the accuracy of a person's own calculations. Numerous tables are given in various parts of this work, attached to the subjects to which they are related.

**TACAMAHAC.** A resin, having the odour of musk, soluble in alcohol.

**TACKLE.** A term sometimes applied to a pair of pulley-blocks and ropes, used for raising or removing weights.

**TACKS.** Small nails. See **NAILS**.

**TAFFETY.** A very rich, glossy, silk stuff, plain, flowered, gold-striped, &c. &c.

**TALC.** A soft unctuous mineral, occurring in beds, in mica-slate, and clay-slate. It is found in several parts of Scotland, but the best comes from the neighbourhood of the Tyrol. It is employed as an ingredient in rouge for the toilette, along with carmine and benzoin. This cosmetic communicates a remarkable degree of softness to the skin, and is not injurious. The flesh polish is given to gypsum figures, by rubbing them with talc.

**TALLOW.** Animal fat melted down and clarified. See **FAT**.

**TAMBOUR.** A species of embroidery, in which threads of gold and silver are, by needles of a peculiar form, worked in leaves and flowers, &c., upon a silk stuff, stretched over a circular frame, called a tambour.

**TANNIN.** A peculiar vegetable principle, so named because it is the effective agent in *tanning*, or the conversion of skin into leather. See **LEATHER**.

**TAPESTRY.** A species of woven hangings of wool and silk, adorned with scenic representations in imitation of painting, and employed formerly for lining the walls of elegant apartments, churches, &c. The French ascribe the invention to the Saracens; and hence the workmen employed in it were called Sarazins. Guicciardini ascribes it to the Dutch. A manufactory was established at Paris, by Henry IV. in 1606 or 1607, which was conducted by Flemish artists. It was brought to England by Wm. Sheldon, in the reign of Henry VIII.; and in 1619 a manufactory was established at Mortlake, in Surrey, by Sir Francis Crane, who received 2000*l.* from King James to encourage the design. The manufactory of the Gobelins in France became the most celebrated for the beauty of the colouring, and the elegance of design; the first-rate painters being employed to furnish subjects.

**TAPIOCA.** A gummy kind of starch, prepared by the Brazilians from the root of the casava plant. A spurious tapioca has been manufactured in this country, from the farina of the potato; the process of preparing the latter consisting simply in exposing the dry farina to the action of a moderate heat in an open pan, and continually stirring it up to prevent carbonization; the water of crystallization of the starch, causing a species of fusion of the starch, which conglomerates into little masses, of a semi-transparent gummy appearance, but with an efflorescent surface, much like the foreign tapioca in appearance; and although it possesses similar properties as an aliment, it does not form so strong, nor so agreeable a "jelly." A patent was recently taken out for the process just described; but unfortunately for the patentee, it was well known, and for nearly half a century before the date of his patent. The advantage of the process is, however, to us more than doubtful, whilst the foreign article can be obtained, subjected to only a moderate import tax.

**TAR.** A thick black unctuous substance, obtained chiefly from old pines and fir trees, by burning them with a close smothering heat. It is prepared in great quantities in Norway, Sweden, Russia, Germany, North America, and in other countries where the pine and fir abound.

The mode practised in the Scandinavian peninsula, is similar to that described by Theophrastus and Dioscorides, as in use in ancient Greece. A conical cavity is made in the earth, with a cast-iron pan at the bottom, to which is connected a pipe to carry off the liquid. Billets of wood are thrown into the cavity, and being then covered with turf, are slowly burnt without flame. The tar which exudes during the combustion, is conducted by the before-mentioned pipe into barrels, which are afterwards bunged up, and are then ready for exportation.



Becher, the celebrated chemist, first proposed to make tar from pit-coal. Manufactures for this purpose have been established many years ago, in several parts of England. In the year 1781, the earl of Dundonald obtained a patent for extracting tar from pit-coal, by a new process of distillation; a kind of tar is also produced from the pit-coal used in the production of gas for illumination. See GAS: also PITCH.

**TARPAULIN.** A piece of strong canvass, or sail-cloth, well saturated with tar, and dried; employed extensively for covering goods in ships, barges, waggons, carts, &c.; also for protecting stacks and ricks of agricultural produce from the effects of the weather, &c.

**TARRAS, or TERRAS.** A volcanic earth used as a cement. It differs but little from puzzolana, but contains more heterogeneous particles, as spar, quartz, shorl, &c. It effervesces with acids, is magnetic, and fusible *per se*. When pulverised, it serves as a cement, like puzzolana. It is obtained from Germany and Sweden.

**TARTAR.** A substance deposited on the sides of wine casks, during the time that the wine is in a state of fermentation. This substance being scraped off, and in its natural and unpurified state, is called by chemists super-tartrate of potash, and popularly, crude tartar. Tartar is distinguished, from its colour, into red and white, according to the colour of the wine from which it originates. All wines do not afford the same proportion of tartar; according to Dr. Newmann, the wines of Hungary yield but little tartar, those of France somewhat more, while the Rhenish wines afford the purest tartar in large quantities. The method adopted at Montpellier, according to Dr. Ure, for purifying this substance from an abundance of extractive principle, is as follows. "The tartar is dissolved in water, and suffered to crystallize by cooling; the crystals are then boiled in another vessel, with the addition of five or six pounds of the white argillaceous earth of Murviel to each quintal of the salt. After this boiling of the earth, a very white salt is obtained by evaporation, which is known by the name of cream of tartar, or the acidulous tartrate of potash," or purified super-tartrate of potash.

*Emetic tartar* is the tartrate of potash, and antimony. *Regenerated tartar*, the acetate of potash. *Salt of tartar*, the subcarbonate of potash. *Soluble tartar*, the neutral tartrate of potash. *Vitriolated tartar*, sulphate of potash.

**TARTARIC ACID.** An acid obtained from the above-mentioned salt tartar by Scheele. In a solution of the super-tartrate in boiling water, he saturated the superfluous acid by the addition of chalk, as long as effervescence ensued; and expelled the acid from the precipitated tartrate of lime, by means of the sulphuric. Or four parts of tartar may be boiled in 20 or 24 parts of water, and one part of sulphuric acid added gradually. By continuing the boiling, the sulphate of potash will fall down. When the liquor is reduced one-half, it is to be filtered; and if any more sulphate be deposited by continuing the boiling, the filtering must be repeated. When no more is thrown down, the liquor is to be evaporated to the consistence of a syrup; and thus crystals of tartaric acid, equal to half the weight of the tartar employed, will be obtained.—*Ure*.

**TARTRATE.** A neutral compound of the tartaric acid, with a base.

**TAWING.** The art of preparing white leather. See LEATHER.

**TEA.** The dried leaves of the tea-plant, which is a native of Japan, China, and Tonquin. The history of commerce does not perhaps present a parallel to the circumstances which have attended the introduction of tea into this country. The leaves were first imported into Europe by the Dutch East India Company, in the early part of the seventeenth century; but it was not until the year 1666 that a small quantity was brought over from Holland; and yet, from a period earlier than the memory of but few of the present generation can reach, tea has been regarded as one of the principal necessaries of life among all classes of the community. To provide a sufficient supply of this aliment, many thousands of tons of the finest mercantile navy in the world are employed in trading with a people by whom all dealings with foreigners are merely tolerated; and from this recently-acquired taste, an immense and easily-collected revenue is obtained by the state.

The tea-plant is an evergreen, somewhat resembling the myrtle in appearance, bears a fragrant yellow flower, and grows to a height varying between three and six feet. It is capable of enduring great variations of climate, being cultivated alike in the neighbourhood of Canton, where the heat is at times almost insupportable to the natives, and around the walls of Pekin, where the winter is, not unfrequently, as severe as in the north of Europe. The best sorts, however, are the production of a more temperate climate; the finest teas are said to be grown in the province of Nanking, occupying nearly the middle station between the two extremes mentioned above; and the greatest portion of what is brought to the Canton market, and sold to the European merchants, is the produce of the hilly, but populous and industrious, province of Fokien, situated on the sea-coast, to the north-east of Canton. It appears to thrive best in valleys, or on the sloping banks of hills, exposed to the southern sun, and especially on the banks of rivers or rivulets.

The tea-plant is propagated from seed, and the holes are drilled in the ground at equal distances, and in regular rows; into each hole the planter throws as many as six, or even a dozen seeds,—not above a fifth part of the seed planted being expected to grow. While coming to maturity, they are carefully watered; and though, when once out of the ground, they would continue to vegetate without further care, the more industrious cultivators annually manure the ground, and clear the crop from weeds.

The leaves of the tea-plant are not fit for gathering until the third year; at which period they are in their prime, and most plentiful. When about seven years old, the shrub has generally grown to about the height of a man, and its leaves become few and coarse; it is then generally cut down to the stem, which, in the succeeding summer, produces an exuberant crop of fresh shoots and leaves; this operation, however, is sometimes deferred till the plant is ten years old.

The process of gathering the tea is one of great nicety and importance. Each leaf is plucked separately from the stalk; the hands of the gatherer are kept carefully clean, and, in collecting some of the fine sorts, he hardly ventures to breathe on the plant. Notwithstanding the tediousness of such an operation, a labourer can frequently collect from four to ten, or even fifteen pounds a day. Three or four of these gatherings take place during the season; viz. towards the end of February, or the beginning of March; in April or May; towards the middle of June; and in August. From the first gathering, which consists of the very young and tender leaves only, the most valuable teas are manufactured; viz. the green tea called gunpowder, and the black tea called Pekoe. The produce of this first gathering is also denominated in China, Imperial tea, probably because, where the shrub is not cultivated with a view to supplying the demands of the Canton market, it is reserved, either in obedience to the law, or on account of its superior flavour, for the consumption of the emperor and his court. From the second and third crops are manufactured the green teas, called in our shops Hyson and Imperial; and the black teas denominated Souchong and Congou. The light and inferior leaves separated from the Hyson by winnowing, form a tea called Hyson-skin, much in demand by the Americans, who are also the largest general purchasers of green teas. On the other hand, some of the choicest and tenderest leaves of the second gathering are frequently mixed with those of the first. From the fourth crop is manufactured the coarsest species of black tea called Bohea; and this crop is mixed with an inferior tea, grown in a district called Woping, near Canton; together with such tea as remained unsold in the market, of the last season.

Owing to the minute division of land in China, there can be few, if any, large tea-growers; the plantations are small, and the business of them carried on by the owner and his own family, who carry the produce of each picking immediately to market, where it is disposed of to a class of persons whose business it is to collect and dry the leaves, ready for the Canton tea-merchants.

The process of drying, which should commence as soon as possible after the leaves have been gathered, differs according to the quality of the tea. Some are only exposed under a shed to the sun's rays, and frequently turned. A

drying-house will contain from five to ten or twenty small furnaces, on the top of each of which is a flat-bottomed and shallow iron pan; there is also a long low table, covered with mats, on which the leaves are spread and rolled, after they have gone through the first stage of the process, which we may call baking. When the pans are heated to the proper temperature, a few pounds of fresh-gathered leaves are placed upon them; the fresh and juicy leaves crack as they touch the pan, and it is the business of the operator to stir and shift them about as rapidly as possible, with his bare hands, until they become too hot to be touched without pain. At this moment, he takes off the leaves with a kind of shovel, like a fan, and pours them on the mats before the rollers, who, taking them up by small quantities at a time, roll them in the palms of their hands, in one direction only; while assistants with fans are employed to fan the leaves, in order that they may be the quicker cooled, and retain their curl the longer. To secure the complete evaporation of all moisture from the leaves, as well as the stability of their curl, the operation of drying and rolling is repeated two or three times, or even oftener, if necessary,—the pans being, on each successive occasion, less and less heated, and the whole process performed with increasing slowness and caution. The leaves are then separated into their several classes, and stored away for domestic use, or for sale. It was, at one time, supposed that the green teas were dried on copper pans, and that they owed their fine green colour to that circumstance, which was also said to render a free use of them noxious to the human frame; but this idea is now held to be without any foundation, the most accurate experiments having failed in detecting the slightest particle of copper in the infusion.

After the tea has been thus gathered by the cultivator, and cured and assorted by those who, for want of a better name, we may call tea-collectors, it is finally sold to the "tea-merchants" of Canton, who complete the manufacture by mixing and garbling the different qualities, in which women and children are chiefly employed; the tea then receives a last drying, is divided according to quality, packed in chests, and made up into parcels of from one hundred to six hundred chests each, which are stamped with the name of the district, grower, and manufacturer, and called from a Chinese word, meaning *seal* or *stamp*, *Chora*.

In perusing the foregoing process of drying the tea, our mechanical readers will probably think with us, that it might be much better (or more uniformly) performed by a machine, heated by steam at a regulated temperature, and that full nine-tenths of the labour would thereby be saved. But as such a proposition to the manufacturers of the "Celestial Empire" would probably be regarded with indignation, and be rewarded, if it were possible, with the bastinado, we shall reserve our suggestions for a fitter object. Those of our readers who may wish for more important information respecting the progress of this important trade, than our limits enable us to give, will find it in M'Culloch's *Dictionary of Commerce*; to which valuable work we are indebted for some of the materials of this article. We have only to observe, that in the century between 1710 and 1810, the teas imported into this country amounted to upwards of 750 millions of pounds, of which more than 630 millions were sold for home consumption; between 1810 and 1828, the total importation exceeded 427 millions of pounds, being on an average, between 23 and 24 millions a year; and in 1831, the quantity imported was 26,043,223 pounds.

**TEAK.** A very valuable timber, which abounds in various parts of the East Indies, and is applied to domestic and nautical purposes. Ships built with teak are far more durable in the Indian seas, than those made of English oak.

**TEAZLE.** A plant, the heads of which are employed in the dressing of woollen cloth, and for which operation no substitute equally effective has hitherto been discovered. The teazle has been considered as affording almost a solitary instance of a natural production being applied to mechanical purposes in the state in which it is produced. It appears, that many attempts have been made to supply a substitute for the teazles, by art, all of which have been abandoned as defective or injurious. The use of the teazle is to draw out the ends of the wool from the manufactured cloth, so as to bring a regular pile or nap upon the surface, free from twistings and knottings, and to comb off the coarse and loose parts

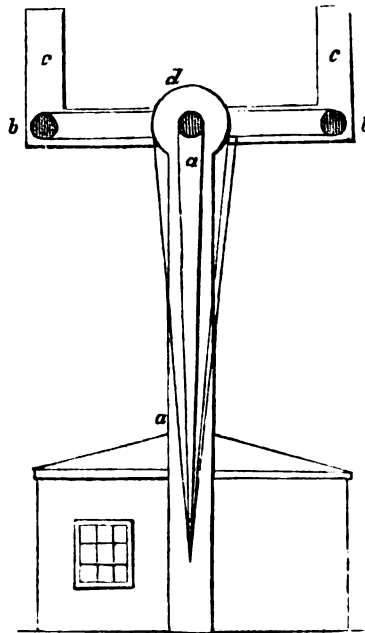
of the wool. The head of the true teazle is composed of incorporated flowers, each separated by a long ridgy chaffy substance, the terminating point of which is furnished with a fine hook. Many of these heads are fixed in a frame; and with these the surface of the cloth is teased or brushed, until all the ends are drawn out, the loose parts combed off, and the cloth yields no impediment to the free passage of the wheel or frame of teazles. Should the hook of the chaff, when in use, become fixed in a knot, or find sufficient resistance, it breaks, without injuring or contending with the cloth; and care is taken, by successive applications, to draw the impediment out; but all mechanical inventions hitherto made use of, offer resistance to the knot; and, instead of yielding and breaking, as the teazle does, resist and tear it out, making a hole, or injuring the surface. The dressing of a piece of cloth consumes from 1500 to 2000 heads, when the work is completely finished: they are used repeatedly in different stages of the process.

**TELEGRAPH.** The name given to a machine, by which intelligence may be transmitted, with extraordinary rapidity, to great distances. There is reason to believe, that the principle of the modern invention of communicating information by means of signals, is of great antiquity. The moderns have, however, the merit of applying the principle, so as to render it a scientific, and almost perfect machine. Polybius described a very complete arrangement of signals by means of torches. The Marquess of Worcester, in his *Century of Inventions*, boasts of being able to do wonders in this way, as he was wont to do in others. Dr. Hook, whose genius as a mechanical inventor was perhaps never surpassed, delivered a "*Discourse to the Royal Society, on the 21st of May, 1684, showing a way how to communicate one's mind at distances*" of 30, 40, 100, and 120 miles, &c. "in as short a time almost as a man can write what he would have sent." In this discourse, which was published in Derham's *Collections of his Experiments and Observations*, the Doctor takes to his aid the then recent invention of the telescope, and explains all the details of the method by which characters exposed at one station, may be rendered plain and distinguishable at the others.

About sixteen years afterwards, Amontons proposed the construction of telegraphs in France; which much resembled Dr. Hook's. The method was as follows:—

Let there be people placed in several stations, at a certain distance from one another, that, by the help of a telescope, a man in one station may see a signal made in the next before him: he must immediately make the same signal, that it may be seen by persons in the station next after him, who are to communicate it to those in the following station, &c. These signals may be as letters of the alphabet, or as a cypher, understood only by the two persons who are in the distant places, and not by those who make the signals. The person in the second station making the signal to the person in the third, the very moment he sees it in the first, the news may be carried to the greatest distance in as little time as is necessary to make the signals in the first station. The distance of the several stations, which must be as few as possible, is measured by the reach of a telescope. Amontons tried this method in a small tract of land, before several persons of the highest rank, at the court of France. It was not, however, till the French revolution, that the telegraph was applied generally to useful purposes. Whether M. Chappe, who is said to have invented the telegraph first used by the French, about the end of 1793, knew any thing of Amontons's invention or not, it is impossible to say; but his telegraph was constructed on principles nearly similar. The manner of using his telegraph was as follows:—At the first station, which was on the roof of the palace of the Louvre, at Paris, M. Chappe, the inventor, received in writing, from the Committee of Public Welfare, the words to be sent to Lisle, near which the French army at that time was. An upright post was erected on the Louvre, at the top of which were two transverse arms, movable in all directions by a single piece of mechanism, and with inconceivable rapidity. He invented a number of positions for these arms, which stood as signs for the letters of the alphabet; and these, for the greater celerity and simplicity, he reduced as much as possible. The grammarian will easily conceive that sixteen signs may amply supply all

the letters of the alphabet, since some letters may be omitted, not only without detriment, but with advantage. These signs, as they were arbitrary, could be changed every week; so that the sign of B, for one day, might be the sign of M, the next; and it was only necessary that the persons at the extremities should know the key. The intermediate operators were only instructed generally in these sixteen signals; which were so distinct, so marked, so different, the one from the other, that they were easily remembered. The construction of the machine was such, that each signal was uniformly given in precisely the same manner at all times; it did not depend on the operator's manual skill; and the position of the arm could never, for any one signal, be a degree higher, or a degree lower,—its movement being regulated mechanically. M. Chappe, having received at the Louvre the sentence to be conveyed, gave a known signal to the second station, which was Mont Martre, to prepare. At each station there was a watch-tower, where telescopes were fixed, and the person on watch gave the signal of preparation which he had received; and this communicated successively through all the line, which brought them all into a state of readiness. The person at Mont Martre then received, letter by letter, the sentence from the Louvre, which he repeated with his own machine; and this was again repeated from the next height, with inconceivable rapidity, to the final station at Lisle. The first description of the telegraph was brought from Paris to Frankfort-on-the-Maine, by a former member of the Parliament of Bourdeaux, who had seen that which was erected on the mountain of Belville. As given by Dr. Hutton, it is as follows:—



*a* is a beam or mast of wood, placed upright on a rising ground, which is about fifteen or sixteen feet high. *b b* is a beam or balance, moving upon the centre *a*. This balance-beam may be placed vertically, or horizontally, or anyhow inclined, by means of strong cords, which are fixed to the wheel *d*, on the edge of which is a double groove, to receive the two cords. This balance is about eleven or twelve feet long, and nine inches broad, having at the ends two pieces of wood *c c*, which likewise turn upon angles, by means of four other cords that pass through the axis of the main balance—otherwise, the

balance would derange the cords; the pieces C are each about three feet long, and may be placed either to the right or left, straight or square, with the balance-beam. By means of these three, the combination of movement is very extensive, remarkably simple, and easy to perform. Below is a small wooden hut, in which a person is employed to observe the movements of the machine. On the eminence nearest to this, another person is to repeat these movements, and a third to write them down. The time taken up for each movement is twenty seconds, of which, the motion alone is four seconds; the other sixteen the machine is stationary. Two working models of this instrument were executed at Frankfort, and sent by Mr. W. Playfair, to the Duke of York; and hence, the plan and alphabet of the machine came to England.

Various experiments were in consequence tried upon telegraphs in this country; and one was soon after set up by government, in a chain of stations from the Admiralty-office to the sea coast.

This telegraph consisted of six octagonal boards, each of which was poised upon a horizontal axis in a frame that surrounded it, in such a manner that each octagonal board might be placed either with its flat side towards the spectator, or edgewise, when the board became invisible owing to the distance. An officer's cabin was placed underneath, provided with a telescope pointed to the next station. By a simple mode of working, these six boards made 36 changes, which are adequate for all occasions. Experience has shown that this plan of telegraph, which was deemed at the time of its introduction to be an improvement upon the design of M. Chappe, previously described, was, in reality, inferior to it in simplicity and clearness; consequently the latter has been since adopted by the British government, under such improved modifications as great practical conversancy in the subject must necessarily produce.

There is probably no subject which has exercised more of the ingenuity of scientific men than that of telegraphic communication; and we are convinced that a description of the various schemes for that object, would alone fill a volume like the present. We shall therefore confine our notice to a very few of them; and, in preference, to such as are upon a totally different principle from each other.

Telegraphic communication, (the ingenious Mr. Vallance observes,) has hitherto been a mean of intercourse that was serviceable only during those portions of the enlightened half of the twenty-four hours, when clear weather admitted of uninterrupted vision for a distance of about ten miles. It has been frequently proposed to remedy this disadvantage, (so far as related to the absence of light, that is,) by nocturnal telegraphs, for the lamps of which, gas seemed so admirably adapted. But as this would do nothing towards lessening the interruption which wet and foggy weather occasion, it has not been thought worth while to incur the expense of it; and as it has also been supposed impossible that these interruptions could be obviated, we have sat down under the impression, that communications, rapid as are those of the telegraph under favourable circumstances, must remain dependent, to a degree that would ever prevent the principle from being rendered available to the purposes of commercial and domestic communication. But this impression is erroneous,—there being a well known principle, by the aid of which information may be communicated equally well during darkness and the most foggy weather, as in daylight and clear weather. The putting of this principle into execution, will of course be incomparably more expensive than laying down a line of telegraphs; but as the revenue it may be made to bring in will, (to use M. Dupin's observation relative to our domestic policy,) render this expenditure but an additional instance of that "economy, well understood, which knows how to make sacrifices bordering almost on prodigality, in order to reap afterwards, with usury, the fruits of its advances," the amount of it in no wise diminishes the attention the principle deserves.

"It has long been known," adds Mr. Vallance, "that an incompressible liquid, confined in a pipe, might be caused to move through the whole length of that pipe, by operating on it at either end, whether the pipe was one mile or one hundred miles long. (It was proved by Bossuet, for a distance of three miles, about half a century ago.) But although this has long been known, and although it offers a mean of symbolic intercourse which would alike be inde-

pendent both of darkness and cloudy days, yet it has been unthought of as a principle of instantaneous transmission." The mode proposed by Mr Vallance, of carrying the principle into practice, may be thus briefly explained.

A pipe of small calibre is to be laid from one to the other of the places, between which, (as hitherto termed,) telegraphic communication is to be effected. This pipe, (effectually secured against leakages,) is to be kept constantly filled with water, by apparatus which both empties it of air and guards against (or rather counteracts) contraction and expansion. Each end of this pipe is connected to apparatus, which will cause any movement of the water inside it, to act on and move a hand. This hand may point out and indicate letters, or numbers, or words, painted on a dial plate; though it will be better to cause it to indicate them when placed in a line. In connexion with telegraphic apparatus, is always understood a vocabulary, connecting the symbols with certain meanings. The principle of this method will admit of either letters, numbers, words, or sentences, being used. Having thus explained the principle of Mr. Vallance's plan, we must refer the reader for the details of it to a pamphlet by the author, published by Wightman, London, 1825, entitled, *Description of a Method of Telegraphic Communication*. A variety of suggestions for the employment of the electric fluid acting upon wires extended from the places in communication, have been made from time to time. In one of these the intelligence is communicated by means of *sound*, produced by the collision of bodies in opposite states of electricity; these bodies consist of a series of small balls, suspended at the extremities of metallic conductors by slender chains, and a series of numbered bells hung within their space of action. The author of this plan, who is an anonymous contributor to a scientific journal, illustrates his proposed scheme by the following example:—

"Let a metallic wire, coated with a non-conducting substance, be extended under ground between any two given places, which, for the sake of experiment, may be two separate apartments in the same house; one of which may be denominated A, and the other B. In the apartment A place an electrical machine, and to the extremity of the wire in B a little ball, suspended by means of a very slender chain, within whose sphere of action there is a common bell. Now, by connecting the wire in A with the conductor of the machine, the electric fluid will pass instantaneously along it, and charge the ball in B, through the medium of its little chain, which flies off immediately to the uninsulated bell, to discharge its surplus of electric matter, and recover its equilibrium. The force by which it is attracted or impelled towards the bell is quite sufficient to produce the sound required; it is an experiment which I have often made, and with invariable success. Let this bell be numbered 1, and have a series of them up to 10, with separate and distinct metallic conductors, it is evident to a demonstration that, by a combination and the successive excitement of these simple numbers, the whole of those at present made use of in our most improved telegraph and signal books, together with their corresponding meanings, may be conveyed from the apartment A to B with the greatest accuracy, and with the speed of thought.

"Thus, by this simple and inexpensive means, (by two electrical machines, and a double series of wires with their appendages,) say between Portsmouth or Plymouth and London, news of the greatest political importance may be conveyed in a few minutes, by a gentleman connected with the apparatus at either of these places; he has only to excite the wires which correspond to each individual number of the telegraph made to him by the common flag signals, which will, in almost the same instant of time, affect their corresponding in London, and give the necessary intelligence in a series of numbers, whose symbols will be found by referring to the signal books now in use.

*Domestic telegraphs* (which are now very common) are designed to prevent the trouble of calling for certain articles in a dwelling-house, and to dispense with one-half of the journeys of the servants in answering bells. They are made in a variety of ways, but usually consist of two circular indexes or dials, equally divided into a given number of parts, and marked on these divisions, with the names of such things or necessaries as are generally wanted in a house, such as dinner, tea, supper, coals, lights, carriage, horse, &c. These indexes exactly

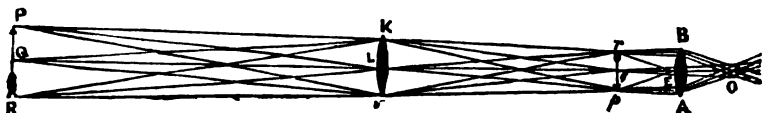
correspond, and are provided with hands, the axes of which pass through pulleys of equal diameter; a wire or chain extends from the pulley of one of them, fixed in the sitting room, to another fixed in the kitchen, or servants' hall. The pulley of the latter contains a spring, and that of the former a ratchet wheel and catch, so that if the hand of the sitting room index be turned, it also turns that of the servants' room an equal portion of a revolution, and thereby points to the same word. The pull is lifted off the ratchet after it is used, by touching a pin, when the spring in the other pulley draws the chain or wire round it, and so returns both the hands to their original place at *o*. The attention of the servant is called by the ringing of a bell.

**TELESCOPE.** An optical instrument, employed for discovering and viewing distant objects; or which magnifies their natural appearance, by representing them under a larger angle than that under which they appear to the naked eye. Telescopes are divided into two general kinds, *refracting* and *reflecting*. A *refracting* telescope consists of different lenses, through which the objects are seen by rays, *refracted* by them to the eye. A *reflecting* telescope, besides lenses, has a metallic speculum within its tube, by which the rays proceeding from an object are *reflected* to the eye.

The principal effect of telescopes depends upon this rule, that objects appear large or small, in proportion to the angle which they subtend to the eye; and the effect is the same, whether the pencils of rays, by which the objects are rendered visible to us, come directly from the objects themselves, or from any point nearer to the eye, where they may have been united, so as to form an image of the object; because they issue again in certain directions from those points, where there is nothing to intercept them, in the same manner as they did from the corresponding points, in the objects themselves. In fact, therefore, all that is effected by a telescope, is, first, to make an image of a distant object, by means of a lens or mirror, and then to give the eye some assistance for viewing that image as near as possible; so that the angle which it shall subtend to the eye, may be very large, compared with the angle which the object itself would subtend in the same situation to the naked eye. This is effected by means of an eye-glass, which so refracts the pencils of rays, that they may afterwards be brought to their several *foci*, by the humours of the eye.

The forms of refracting and reflecting telescopes have been frequently varied, and they are sometimes distinguished by the names of their inventors, as the *Galilean*, and the *Newtonian* telescope; sometimes by the particular use for which they are best adapted, as the "*land telescope*," the "*night telescope*," the "*astronomical telescope*," &c.

The astronomical telescope consists of two convex lenses, A B, K M, each fixed at the extremity of a different tube. One of the tubes is very short, as its use is merely to adjust the focus in proportion to the distance of the object viewed, and it slides within the other. Contrary to the arrangement which takes place in the microscope, the glass which has the longest focus, is presented to the object, and therefore constitutes the object-glass. P R, represents a very distant object, from every point of which rays come, so very little diverging to the object-lens K M of the telescope, as to be nearly parallel: *p r*, is the picture of the object P R, which would be formed upon a screen situated at that place. Beyond that place, the rays of every single radiant point proceed divergently to the eye-glass A B, of greater convexity, and which causes the rays of each pencil



to become parallel, in which direction they enter the eye at *O*. The axes of the two lenses are coincident in the direction *Q L O*; *L q*, is the focal distance of the object-glass, and *E g*, is the focal distance of the eye glass; consequently,

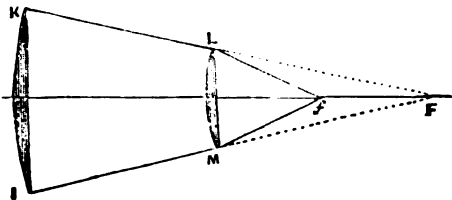


the distance between the two glasses is equal to the sum of their focal distances. An object viewed through this telescope, by an eye situated at O, will appear magnified and distinct, but inverted. The object seen without the telescope, will be, to its appearance, through the telescope, as  $q E$  to  $q L$ ; that is, as the focal distance of the eye-glass, to the focal distance of the object-glass. For the pencils of rays, which, after their crossing at  $r q p$ , proceed divergently, fall upon the lens A B, in the same manner as if a real object were situated at  $r q p$ ; and consequently, after passing through that lens, the rays of each pencil proceed parallel. To the eye at O, the apparent magnitude of the object P R, is measured by the angle B O A, or by its equal  $p E$ ; but, to the naked eye at L, when the glass is removed, the apparent magnitude of the object is measured by the angle P L R, or by its equal  $r L p$ ; therefore, the apparent magnitude to the naked eye, is to the apparent magnitude through the telescope, as the angle  $r L p$ , is to the angle  $p E r$ ; or, as the distance  $q E$ , is to the distance  $q L$ .

If the angles  $r L p$ , and  $p E r$ , were equal to each other, the telescope would not magnify, and they would be equal, if the lenses were of equal focal distance. Hence, as the magnifying power of the telescope is produced by making the focal distance of the eye-glass less than that of the object-glass, it will easily be perceived, that the greater the difference of the focal lengths, the greater will be the magnifying power. It is found, however, that they may be so disproportionate, that the increased magnifying power is overbalanced by the indistinctness which ensues. In order, therefore, to obtain a great magnifying power with the preservation of just proportion, these telescopes have sometimes been made one hundred feet, or upwards, in length; and, as they were mostly used for astronomical purposes, they were frequently used without a tube. The object lens was fixed on the top of a pole, in a frame capable of being moved by a cord or wire, in any required direction, and the eye-glass, fixed in a short tube, was held in the hand, or fitted to another frame, about the height of the observer, so as to be capable of a simultaneous movement. A telescope of this description was called an *aërial* telescope. Its use was evidently very inconvenient; but, such were the great pains taken by philosophers, in exploring the wonders which even the imperfect telescopes, at first constructed, promised to lay open, that with such an instrument, the five satellites of Saturn, and many other remarkable objects, were discovered.

The length of common refracting telescopes must be increased in the proportion of the square of the increase of their magnifying power; so that, in order to magnify twice as much as before, with the same degree of light and distinctness, the telescope must be lengthened four times; and to magnify three times as much, nine times. On this account, their unwieldy length, when great powers are desired, is unavoidable. The breadth of an object-glass adds nothing to the magnifying power; for, whatever the latter may be, the image will be equally formed at the distance of its focal length; but the *brilliance* of the image will be increased by the breadth, as a greater number of rays will then diverge from every point of the image.

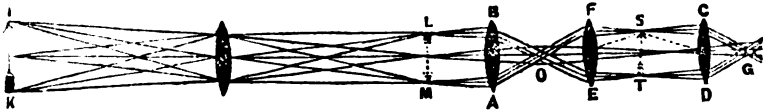
The magnifying power, and the field of view, of this telescope may be increased by using two plano-convex lenses, combined so as to act like one glass;



and such a combination is now generally employed. If two plano-convex lenses be used, the curvature of both conjointly, will be less than the curvature of a

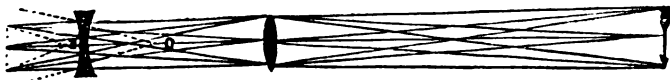
single lens of equal magnifying power; the combination therefore improves the eye-glass of a telescope, because the aberration of the rays passing through it, will be less than through a single lens of the same focus. Suppose  $I K$  to be a plano-convex lens, of which the focus is at  $F$ , so that an object placed at  $F$  would be seen magnified through it. If another lens  $L M$ , be placed between the first lens and its focus, the focus of the rays passing through both will be shortened, and will fall at about the distance  $f$ , so that, when thus combined, they will act like a single lens of much greater curvature. The telescope called a *night-glass*, is simply a common astronomical telescope with tubes, and made of a short length, with a small magnifying power. It generally magnifies from 6 to 10 times. It is used by navigators at night, for the purpose of discovering objects that are not very distinct, such as vessels, coasts, rocks, &c. From the smallness of its magnifying power it admits of large glasses being used, and consequently has a well-enlightened field of view.

The astronomical telescope, by the use of two additional eye-glasses, shows objects in their right position, and become a *terrestrial* or *land* telescope; and is sometimes called a *perspective* glass. This telescope is shown by the following cut. The rays of each pencil coming from the image  $L M$ , of the object



$I K$ , emerge parallel from the lens  $A B$ , and having crossed at its focus  $O$ , they continue in that direction to the lens  $E F$ ; in consequence of which they form an image  $S T$ , at the focus of the second lens; and again diverging, they fall upon the third lens  $C D$ , in the same manner as they did upon the lens  $A B$ ; therefore after their emergence from this last lens, they fall parallel upon the eye at  $G$ . But as the last image  $S T$ , is not inverted as at  $L M$ , but in the same position as the object  $I K$ , the eye sees a true or upright picture, as if the rays had come directly from the object. The last lens, or the one nearest the eye, is now generally made of two plano-convex lenses, instead of a double convex one. By this means, all the best terrestrial telescopes contain four lenses in the tube next the eye.

The telescope of the celebrated Galileo consists of a convex object-glass, and a concave eye-glass, as represented by the following cut. The distance between the two lenses is less than the focal distance of the object-glass; but the concave glass is situated so as to make the rays of each pencil fall parallel upon the eye, as is evident by conceiving the rays to go back again through the eye-glass towards  $O$ :  $E O$  being the focal length of the eye-glass. The field of view of the Galilean telescope does not depend, as in those with convex glasses, upon the size of the eye-glass, but upon the breadth of the pupil of the eye; because the lateral pencils of rays diverge from the axis of the eye-glass at their emergence from it. On this account, the eye should be placed as near to the eye-glass as possible, in order that it may receive the greatest number of



pencils. No nearness of the eye, however, will wholly prevent the field of view from being more confined than with convex eye-glasses of equal curvature; but this disadvantage is counterbalanced by the valuable property of superior distinctness.

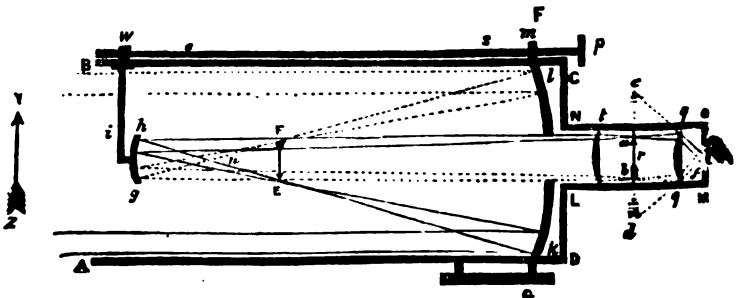
The telescopes which we have hitherto described will only bear a small aper-

ture, without exhibiting circular prismatic rings of colours, which are detrimental to their utility. Two causes contribute to this effect. 1. Spherical surfaces do not refract the rays of light accurately to a point; and 2. The rays of compounded light being differently refrangible, come to their respective focus at different distances from the lens; the more refrangible rays converging sooner, of course, than the less refrangible. If the image of a paper painted entirely red, be cast, by means of a lens, upon a screen, it will be formed at a greater distance than the image of a blue paper cast by the same lens. The image of a white object is composed of an indefinite number of coloured images, the violet being the nearest, and the red the farthest from the lens; and the images of intermediate colours at intermediate distances. The whole image is therefore in some degree confused, though its extremities are most so; and this confusion being increased, not only by the magnifying power of the eye-glass, but also by the dispersive power which it has in common with the object-glass, the necessity for a certain proportion between the powers of the object and the eye-glass becomes indispensable.

The late Mr. John Dolland, by making a compound lens of three different substances, of different refrangible powers, the rays of light which were too much dispersed by one convex lens, were brought nearer to a union with each. The telescopes made with an object-glass of this kind are now commonly used, and are distinguished by the name of *achromatic* telescopes, a term which signifies *colourless*. The object-glasses of Dolland's telescopes are composed of three distinct lenses, two of which are convex, and the other concave. The achromatic effect may be produced by the union of one convex and one concave lens, but not so perfectly as with three lenses.

The impossibility, however, of obtaining perfectly homogeneous glass, and the consequent failure of producing that complete correction of the aberration of the rays of light in the telescopes called achromatic, induced Dr. Blair to try the effects of *fluid* mediums; and his success was such as to induce him to give the term *aplanatic*, or *free from error*, to the object lenses he thus constructed. He made a compound lens, consisting of a plano-convex of crown glass, with its flat side towards the object, and a meniscus of the same material, with its convex side in the same direction, and its flatter concave next the eye; and the interval between the lenses he filled with a solution of antimony in a certain proportion of muriatic acid. The lens thus constructed did not exhibit the slightest vestige of any extraneous colour; but the invention, after a lapse of more than twenty years, has not come into general use, probably from the difficulty of preserving any fluid from growing turbid in the course of time.

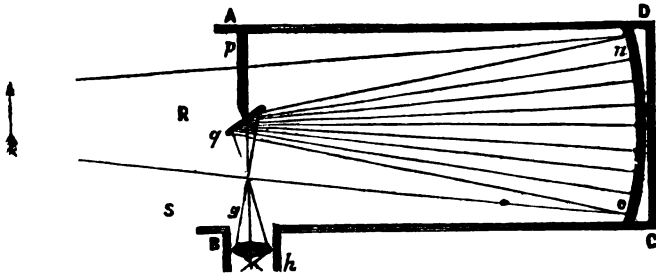
Of reflecting telescopes, the Gregorian is the one most generally used. The construction of this instrument is represented below.



At the bottom of the tube A B C D, is placed the large concave reflector  $KL$  with a circular hole through the middle of it, in the direction of its axis. Within the tube of the telescope, and directly facing the perforation, is placed

the small concave speculum  $gh$ , supported by the arm  $i$ . Two lenses,  $tt$  and  $qq$ , are contained in the eye-tube  $LMNO$ , and the observer applies his eye to a small hole at  $f$ , in order to view the magnified image of the distant object  $YZ$ . The large reflector  $kl$  receives the rays from the distant object, and reflects them to its focus, where they form an inverted image  $E F$ . Diverging from the points of union, the pencils of rays proceed onwards, and cross each other a little before they reach the small mirror  $gh$ : the focus of which is at  $\pi$ , or a little further from the large speculum, than its principal focus. From the small mirror, the rays are reflected somewhat convergently, and in that state are received before they meet a plain convex lens  $tt$ . By the action of this lens, their convergency is increased, and they form a second image,  $a b$ , which is erect like the object. This second image is magnified by the lens  $qq$ , through which the rays of each pencil pass nearly in a parallel direction to the eye. To exclude all extraneous light, the eye is applied to a small hole, and sees the image under the angle  $cf d$ . If the lens  $tt$  were removed, the image would be formed somewhat larger at  $r$ , but the area, or field of view, would be smaller and less pleasant, for which reason it is not usual to omit the second lens. In this, and other reflecting telescopes, containing two curved reflectors, it is necessary to have the power of altering the distance between the two mirrors. This is usually done by a wire,  $es$ , passing along the outside of the tube and with a screw at the end of it, which works in an external projection  $w$ , of the arm  $i$ , within the tube. The other end of the wire passes through a small stud affixed to the tube of the telescope at  $m$ ; and the observer, while looking through the hole at  $f$ , turns the milled head  $p$ , of the wire, which is near him, and thus regulates the distance of the small speculum, as he finds requisite.

A section of the Newtonian Reflecting Telescope is shown below.



A B C D, is the tube, which is open at the end A B, opposite the large speculum  $no$ . The large concave speculum  $no$ , is not perforated as in the Gregorian telescope, but the small speculum  $q$ , is set aslant, so as to direct the rays received from the large speculum, through an aperture  $g$ , at the side of the tube, where they are received and refracted to the eye by a lens or lenses in a tube  $h$ . The speculum  $q$ , is suspended within the tube, by an arm  $p$ , with its centre opposite the centre of the speculum  $no$ ; it is not curved, but plane, and has therefore no other effect than that of changing the direction of the rays. Without the small reflector, the rays from the large speculum would be converged at  $R$ , and the observer might have an eye-glass placed to view the image formed there, with his face towards the speculum  $no$ ; but in this case his head would intercept the greater part of the rays, unless the instrument were very large. The Newtonian telescope, as first described, is very convenient for viewing objects in the zenith; as they may be seen while the observer retains his ordinary position of looking forward horizontally.

The best and most powerful reflecting telescopes, however, which have ever been constructed, are those of Dr. Herschel, who is so well known by his labours, as one of the most eminent astronomers of the present day. The largest reflecting telescope made by Dr Herschel, is forty feet in length, and

the polished surface of the large speculum is four feet in diameter. It has no second reflector; a circumstance that adds much to the brightness of the objects viewed in it. The observer, who looks through an eye-glass, as in other telescopes, has, of course, his back to the object; but it is so contrived that little or no light is intercepted by this means. We may use the foregoing diagram of the Newtonian telescope, on page 773, to illustrate the position of the observer, by this telescope, more particularly. Supposing the speculum  $q$ , and its support to be removed, the rays  $no$ , as before observed, would be converged at  $R$ ; but if the observer were placed there, he would intercept a large portion of the light, even when facing this gigantic telescope. Supposing the upper part  $n$ , of the speculum, to be inclined downwards, that is, to be set at an angle to the axis of the tube, the rays may be directed to  $S$ , or any other point nearer the tube, where the spectator may be placed, and will occasion no sensible dimness of the image thrown by the large mirror. In Dr. Herschel's large telescope, the converging rays reflected by the mirror pass the extremity of the tube, at the distance of four inches from it, and come into the air; by this means the observer scarcely at all interferes with the incident light, as the diameter of the tube exceeds that of the mirror, by about ten inches. The mirror has a magnifying power of six thousand times the diameter of an object.

**TELLURIUM.** A metal discovered by Klaproth in 1798, in an ore of gold from Transylvania. It has a silver-white colour, and possesses much brilliancy. Its texture is laminated like antimony, and has a specific gravity of 6.115. It is very brittle, may be easily reduced to powder, and melts at a temperature a little higher than lead does. If the heat be increased a little above the fusing point, it boils and evaporates, and attaches itself in brilliant drops on the upper part of the retort in which the experiment is made; it is, therefore, next to mercury, and arsenic, the most volatile of the metals. It combines with oxygen only in one proportion, forming therewith a compound possessing acid properties.

**TEMPERATURE.** Implies that degree of sensible heat, which a body possesses when compared with other bodies. To accurately measure and determine such degrees of heat, so as to be readily comprehended, thermometers have been constructed; in which some universally understood degree of heat, as that of boiling water, is made the basis of the calculation for all other temperatures.

**TEMPERING.** The art of altering the existing degree of elasticity in metals. See IRON.

**TENACITY.** A term derived from the Latin, implying the property of holding fast, firmness, &c.; some authors restrict its application to that force by which metals resist their being pulled, or torn asunder; as the action of a weight suspended to the end of a wire; and make a distinction between it, and the term *cohesion*, which of course implies that force by which the parts of bodies cohere. The real distinction, if any, is however so refined, that we may without much impropriety treat them here as the same force.

The tenacity or cohesion of solids is measured by the force required to pull them asunder; and authors on the subject in general agree, that it may be calculated from the transverse strength of the bar or rod, as near, or perhaps nearer to the real cohesion, than can be obtained by pulling the body asunder; but we find that this assertion, however correct it may appear from abstract reasoning, is at variance with the most prominent facts derived from actual experiment, and given by the same authors. By the experiments of Emerson, it is stated that a wire of iron, one-tenth of an inch in diameter, requires a force of 450lbs. to pull it asunder; and according to Rumford, that an inch cylinder or rod of iron, required a pull of 63,320lbs. to break it. Now the area, or transverse section of the inch rod is 785; in other words, it contains 78 wires of one-tenth of an inch in diameter; therefore the aggregate strength of the 78 wires, ought according to the doctrine laid down, to be equal to 63,320lbs.; but  $78 \times 450$ , make only 35,100; and thus it appears that calculation by the transverse strength, taking the wire for our datum, gives us but little more than half the real tenacity of the inch rod; and if we were to take the inch rod for our datum of calculation, we find  $(78 \div 63,320 = 81\frac{1}{2})$ ;

that each wire should sustain a force of 811lbs. Indeed, rather more than this, for we are further told, (and we do not dispute its general accuracy,) that "the cohesive force of metals is much increased by wire-drawing, rolling, and hammering." Such *illustrations* of the correctness of a theory, we have thought it necessary to notice, as it might prove of very serious consequence, were an engineer (for instance) to construct a wire bridge, founded upon calculations of the given transverse strength of a rod of iron. His only security, it appears to us, would be to prove, himself, the actual tenacity of the identical material he employs, and not place much dependence upon the experiments of others; for, however judiciously the latter may have been conducted, or faithfully detailed, there is such a wide difference in the results of experiments made upon the same nominal material, that it is only by a great number of experiments that any useful approximation to the truth can be obtained. Mr. John Rennie, who has most laudably and ably exerted himself in this field of inquiry, found many such discordant results as those we have detected. In a paper furnished to the Royal Society, that engineer states, that it had been deduced from the experiments made by Reynolds, that the power required to crush a cubic quarter of an inch of cast iron was 448,000lbs. avoirdupois, or 200 tons; whereas, by the average of thirteen experiments made by Mr. Rennie, in cubes of the same size, the amount never exceeded 10,392lbs.—not 5 tons!

The desire of obtaining some approximation, which could only be accomplished by repeated trials on the substances themselves, induced Mr. Rennie to undertake the following experiments.

The apparatus used for this purpose was a powerful lever of the second class; it consisted of a flat bar of the best English iron, about ten feet long, one of the extremities being formed into a rule-joint, by which it was attached to a stout and short standard of wrought iron, that was bolted to a massive bed-plate of cast iron; the hole in the centre of the joint, and the pin which formed the fulcrum, were accurately turned, so as to move slowly and freely. The lever was accurately divided on its lower edge, which was made straight in a line with the fulcrum. A point or division was selected, at five inches from the fulcrum, at which place was let in a piece of hardened steel. The lever was balanced by a weight, and in this state it was ready for operation. But, in order to keep it as level as possible, a hole was drilled through a projection on the bed-plate, large enough to admit a stout bolt easily through it, which again was prevented from turning in the hole by means of a tongue fitting into a corresponding groove in the hole, so that, in order to preserve the level, it was only necessary to move the nut, to elevate or depress the bolt, according to the size of the specimen. But as an inequality of pressure would still arise, from the nature of the apparatus, the body to be examined was placed between two pieces of steel, the pressure being communicated through the medium of two pieces of thick leather, above and below the steel pieces, by which means a more equal contact of surfaces was obtained. The scale was hung on a loop of iron, touching the lever in an edge only. At first a rope was used for the balance weight, which indicated a friction of four pounds, but a chain diminished the friction one half. Every movable centre was well oiled.

In Mr. Rennie's experiments on the cohesive strength of cast iron, to resist compression, there were four kinds of iron used; *viz.* 1. Iron taken from the centre of a large block, whose crystals were similar in appearance and magnitude to those evinced in the fracture of what is usually termed gun-metal. 2. Iron taken from a small casting, close-grained, and of a dull grey colour. 3. Iron cast horizontally, in bars of three-eighths of an inch square, eight inches long. 4. Iron cast vertically, same size as last. These castings were reduced equally on every side, to one quarter of an inch square; thus, removing the hard external coat, usually surrounding metal castings. They were all subjected to a gauge; the bars were then presumed to be tolerably uniform. The weights used were of the best kind that could be procured, and, as the experiment advanced, smaller weights were used.

As we have not space for detailing the particulars of each experiment, we here add only the *average* results of them.

The experiments on cast iron, in cubes of one-eighth of an inch,—specific gravity 7.033, gave 1439 lbs. avoirdupois, as the average force required to crush them.

On specimens of the same iron, one-eighth of an inch square, and one-fourth of an inch long, the average force required was 2116 lbs.

On specimens of the same thickness, but varying in length from one-half of an inch to one inch, the average result was 1758 lbs.

On cubes of a quarter of an inch of the same metal, gave 9773 lbs. as the average result.

On one-fourth of an inch cubes, made from horizontal castings of specific gravity, 7.113 gave 10,114 lbs. as the average.

On one-fourth of an inch cubes, vertical castings, specific gravity 7.074, the average was 11,136 lbs.

A prism, having a logarithmic curve for its limits, resembling a column, (it was one-fourth of an inch diameter, by one inch long,) broke with 6954 lbs.

The trials on prisms, of different lengths, one-fourth and one-half horizontal, gave 9414 lbs.

The same, vertical, gave 9982 lbs.

Horizontal castings, varying from three-eighths to six-eighths of an inch  $\times$   $\frac{1}{2}$ , gave an average of 8738 lbs.

Vertical ditto, gave 8536 lbs.

#### *Experiments on different Metals.*

		lbs.
$\frac{1}{2} \times \frac{1}{2}$	cast copper, crumbled with . . . . .	7318
"	fine yellow brass reduced $\frac{1}{10}$ with 3213 $\frac{1}{2}$ lbs. with . . . . .	10304
"	wrought copper . . . . .	6440
"	cast tin . . . . .	966
"	cast lead . . . . .	483

The experiments on the different metals gave no satisfactory results. The difficulty consists in assigning a value to the different degrees of diminution. When compressed beyond a certain thickness, the resistance becomes enormous.

#### *Experiments on the Suspension of Bars.*

The lever was used as in the former case, but the metals were held by nippers. They were made of wrought iron, and their ends adapted to receive the bars, which, by being tapered at both extremities, and increasing in diameter from the actual section, and the jaws of the nippers being confined by a hoop, confined both. The bars, which were six inches long, and one quarter square, were thus fairly and firmly grasped.

	lbs.
$\frac{1}{2}$ inch cast-iron, horizontal . . . . .	1166
$\frac{1}{2}$ ditto ditto, vertical . . . . .	1218
$\frac{3}{4}$ ditto cast-steel, previously tilted . . . . .	8391
$\frac{1}{2}$ ditto blister steel, reduced per hammer . . . . .	8322
$\frac{1}{2}$ ditto shear steel . . ditto . . . . .	7977
$\frac{3}{4}$ ditto Swedish iron . . ditto . . . . .	4504
$\frac{1}{2}$ ditto English iron . . ditto . . . . .	3492
$\frac{3}{4}$ ditto hard gun-metal, mean of two trials . . . . .	2273
$\frac{1}{2}$ ditto wrought copper, reduced per hammer . . . . .	2112
$\frac{1}{2}$ ditto cast copper . . . . .	1192
$\frac{3}{4}$ ditto fine yellow brass . . . . .	1123
$\frac{1}{2}$ ditto cast tin . . . . .	296
$\frac{1}{2}$ ditto cast lead . . . . .	114

#### *Experiments on the Twist of $\frac{1}{2}$ inch Bars.*

To effect the operation of twisting off a bar, another apparatus was prepared. It consisted of a wrought-iron lever, two feet long, having an arched head about

one-sixth of a circle, of four feet diameter, of which the lever represented the radius; the centre, round which it moved, had a square hole made to receive the end of the bar to be twisted. The lever was balanced as before, and a scale hung on the arched head; the other end of the bar being fixed in a square hole in a piece of iron, and that again in a vice. By this apparatus, quarter of an inch bars, from horizontal castings, were twisted with weights in the scale, averaging 9 lbs. 15 oz. The vertical castings took 10 lbs. 10 oz. as an average.

*On different Metals.*

	lbs.	oz.	
Cast steel . . . . .	17	9	in the scale.
Shear steel . . . . .	17	1	
Blister steel . . . . .	16	11	
English iron, wrought . . . . .	10	2	
Swedish iron, wrought . . . . .	9	8	
Hard gun-metal . . . . .	5	0	
Fine yellow brass . . . . .	4	11	
Copper, cast . . . . .	4	5	
Tin . . . . .	1	7	
Lead . . . . .	1	0	

*On Twists of different Lengths.—Horizontal.*

	lbs.	oz.	
$\frac{1}{4}$ by $\frac{1}{4}$ long . . . . .	7	3	weight in scale.
$\frac{1}{4}$ by $\frac{1}{2}$ ditto . . . . .	8	1	
$\frac{1}{4}$ by 1 inch ditto . . . . .	8	8	

*Vertical.*

$\frac{1}{4}$ by $\frac{1}{4}$ ditto . . . . .	10	1
$\frac{1}{4}$ by $\frac{1}{2}$ ditto . . . . .	8	9
$\frac{1}{4}$ by 1 inch ditto . . . . .	8	5

Horizontal twists of quarter of an inch bars, at six inches from the bearing, took an average of 9 lbs. 12 oz. in the scale.

*Twists of  $\frac{1}{4}$  inch square Bars, cast horizontally.*

	qrs.	lbs.	oz.	
$\frac{1}{4}$ close to the bearing . . . . .	3	9	12	end of the bar hard.
$\frac{1}{4}$ ditto . . . . .	2	18	0	middle of the bar.
$\frac{1}{4}$ at 10 inches from bearing, lever in the middle . . . . .	1	24	0	

*On Twists of different Materials.*

These experiments were made close to the bearing, and the weights were accumulated in the scale, until the substances were wrenched asunder.

	lbs.	oz.	
Cast steel . . . . .	19	9	weight in scale.
Shear steel . . . . .	17	1	
Blister steel . . . . .	16	11	
English iron, No. 1. . . . .	10	2	
Swedish iron . . . . .	9	8	
Hard gun-metal . . . . .	5	0	
Fine yellow brass . . . . .	4	11	
Copper . . . . .	4	5	
Tin . . . . .	1	7	
Lead . . . . .	1	0	





*Miscellaneous Experiments on the Crush of 1 cubic inch.*

	lbs. avoird
Elm . . . . .	1284
American pine . . . . .	1606
White deal . . . . .	1928
English oak, mean of two trials . . . . .	3860
Ditto, of five inches long, slipped with . . . . .	2572
Ditto, of four inches long, slipped with . . . . .	5147
A prism of Portland stone, two inches long . . . . .	805
Ditto, statuary marble . . . . .	3216
Craig Leith . . . . .	8688

In the following experiments on stones, the pressure was communicated through a kind of pyramid, the base of which rested on the hide leather, and that on the stone. The lever pressed upon the apex of the pyramid. The cubes were of one and a half inch.

	Spec. grav.	lbs. av.
Chalk . . . . .		1127
Brick, of a pale red colour . . . . .	2.085	1265
Roe-stone, Gloucestershire . . . . .		1449
Red brick, mean of two trials . . . . .	2.168	1817
Yellow-faced baked Hammersmith paviments three times . . . . .		2254
Burnt ditto, mean of two trials . . . . .		3243
Stourbridge, or fire brick . . . . .		3864
Derby grit, a red friable sandstone . . . . .	2.316	7076
Ditto, from another quarry . . . . .	2.428	9776
Killaly white freestone, not stratified . . . . .	2.423	10264
Portland . . . . .	2.428	10284
Craig Leith, white freestone . . . . .	2.452	12346
Yorkshire paving, with the strata . . . . .	2.085	12856
Ditto, against the strata . . . . .	2.507	12856
White statuary marble, not veined . . . . .	2.760	13632
Branley Fall sandstone, near Leeds, with strata . . . . .	2.506	13632
Ditto, against the strata . . . . .	2.506	13632
Cornish granite . . . . .	2.662	14302
Dundee sandstone or breccia, two kinds . . . . .	2.530	14918
A two-inch cube of Portland . . . . .	2.423	14918
Craig Leith, with the strata . . . . .	2.452	15560
Devonshire red marble, variegated . . . . .		16712
Compact limestone . . . . .	2.584	17354
Peterhead granite, hard, close-grained . . . . .		18636
Black compact limestone, Limerick . . . . .	2.598	19924
Purbeck . . . . .	2.599	20610
Black Brabant marble . . . . .	2.697	20742
Very hard freestone . . . . .	2.528	21254
White Italian veined marble . . . . .	2.726	21783
Aberdeen granite, blue kind . . . . .	2.625	24556

N.B.—The specific gravities were taken with a delicate balance, made by Creighton, of Glasgow, all, with the exception of two specimens, which were by accident omitted.

*Remarks.*—In observing the results presented by the preceding table, it will be seen that little dependence can be placed on the specific gravities of stones, so far as regards their cohesive powers, although the increase is certainly in favour of their specific gravities. But there would appear to be some undoubted law in the connexion of bodies, with which the specific gravity has little to do. Thus, statuary marble has a specific gravity above Aberdeen granite, yet a

cohesive power not much above half the latter. Again, hardness is not altogether a characteristic of strength, inasmuch as the limestones, which yield readily to the scratch, have nevertheless a cohesive power approaching to granite itself.

*Experiments made on the transverse strain of Cast Bars, the ends loose.*

	Weight of the bars lbs. oz.	Distance of bearings ft. in.	lbs. av.
Bar of 1 inch square . . . . .	12 6	3 0	897
Ditto of 1 inch ditto . . . . .	9 8	2 8	1086
Half the above bar . . . . .		1 4	2320
Bar of 1 inch square through the dia- gonal . . . . .	2 8	2 8	851
Half the above bar . . . . .		1 4	1587
Bar of 2 inches deep, by $\frac{1}{2}$ inch thick . . . . .	9 5	2 8	2185
Half the above bar . . . . .		1 4	4508
Bars 3 inches deep, by $\frac{1}{2}$ inch thick . . . . .	9 15	2 8	3588
Half the above bar . . . . .		1 4	6854
Bar 4 inches, by $\frac{1}{2}$ inch thick . . . . .	9 7	2 8	3979
Equilateral triangles, with the angles up and down, viz., with the edge or angle up . . . . .	9 11	2 8	1437
With the angle down . . . . .	9 7	2 8	840
Half the first bar . . . . .		1 4	3059
Half the second bar . . . . .		1 4	1656
A feather-edged bar was cast, whose dimensions were 2 inches deep by 2 wide, edge up . . . . .	10 0	2 8	3105

N.B.—All these bars contained the same area, though differently distributed as to their forms.

*Experiments made on the Bar of 4 inches deep by  $\frac{1}{2}$  inch thick, by giving it different forms, the bearings at 2 feet 8 inches, as before.*

	lbs.
Bar formed into a semi-ellipse, weighed 7 lbs . . . . .	4000
Ditto parabolic on its lower edge . . . . .	3860
Ditto of 4 inches deep by $\frac{1}{2}$ inch thick . . . . .	3979

*Experiments on the transverse strain of Bars, one end made fast, the weight being suspended at the other, at 2 feet 8 inches from the bearing.*

	lbs.
An inch-square bar bore . . . . .	280
A bar 2 inches deep by $\frac{1}{2}$ an inch thick . . . . .	539
An inch bar, the ends made fast . . . . .	1173

The paradoxical experiment of Emerson was tried, which states, that by cutting off a portion of an equilateral triangle, (see page 114 of Emerson's Mechanics,) the bar is stronger than before; that is, a part stronger than the whole. The ends were loose at two feet eight inches apart, as before. The edge from which the part was intercepted was lowermost; the weight was applied on the base above; it broke with 1129 pounds, whereas in the other case it bore only 840 pounds.

A wire of one-tenth inch diameter of	Lead breaks with	lbs.	Emerson.
Do. do.	Tin do.	29 $\frac{1}{2}$	"
Do. do.	Copper do.	49 $\frac{1}{2}$	"
Do. do.	Copper do.	299 $\frac{1}{2}$	"
Do. do.	Brass do.	360	"

A wire of one-tenth inch diameter of <i>Silver</i> breaks with	lbs.	370	Emerson.
Do. do. <i>Iron</i> do.	150	"	
Round bar, 1 inch do. ,, do.	63320	Rumford	

The relative cohesive strength of the metals are, according to Sickengen, as follow :—

Gold . . . . .	150,955
Silver . . . . .	190,771
Platina . . . . .	262,361
Copper . . . . .	304,696
Soft Iron . . . . .	362,927
Hard Iron . . . . .	559,880

But their hardness, according to Cavallo, follows this order, viz., Iron, Platinum, Copper, Silver, Gold, Tin, Lead.

Banks observes that iron is about four times as strong as oak, and six times as strong as deal. Wood is from seven to twenty times weaker transversely than longitudinally. It becomes stronger both ways when dry.

**TENON.** The end of a bar of metal or piece of wood reduced in its dimensions, so as to fit a hole in another piece, called a mortise, and thus joining the two together.

**TENSION.** Is the state of a thing stretched; this term is much used by engineers to express the tenacity of metals and other substances, when pulled in the direction of their length; thus a wire of one-tenth of an inch in diameter, is said to be capable of resisting a tension of 450 pounds.

**TENTER, trier, or prover,** a machine or frame, used in the cloth manufactory, to stretch out the pieces of cloth, and make them set even and square. It is usually about 4½ feet high, and for length exceeds that of the longest piece of cloth. It consists of several long square pieces of wood, placed like those which form the barriers of a menage; so, however, as that the lower cross pieces of wood may be raised or lowered, as is found requisite, to be fixed at any height, by means of pins. Along the cross pieces, both the upper and the lower one, are numerous sharp hooked nails, called tenter-hooks, on which the selvages of the cloth are hooked.

**TESSELLATED PAVEMENTS.** Pavements of different coloured stones, tiles, or brick, laid chequer-wise, or like dice (tessellæ.) The term tessellated is, however, extended to all kinds of mosaic patterns or designs.

**TEST.** Any solid or fluid body, which, added to a substance, teaches us to distinguish its chemical nature or composition.

**THEATRE.** An edifice or great room for the public exhibition of scenic representations, the performance of the drama, of concerts, the delivery of scientific lectures and demonstrations, &c. Considering that the description of a theatre for the latter purpose will not be out of place in this work, and be acceptable to our readers, we shall here annex an account of the lecture theatre of the London Mechanics' Institution; which may serve the purpose of a model whereon similar undertakings may be constructed and arranged, making such alterations and modifications as will better adapt them to other circumstances.

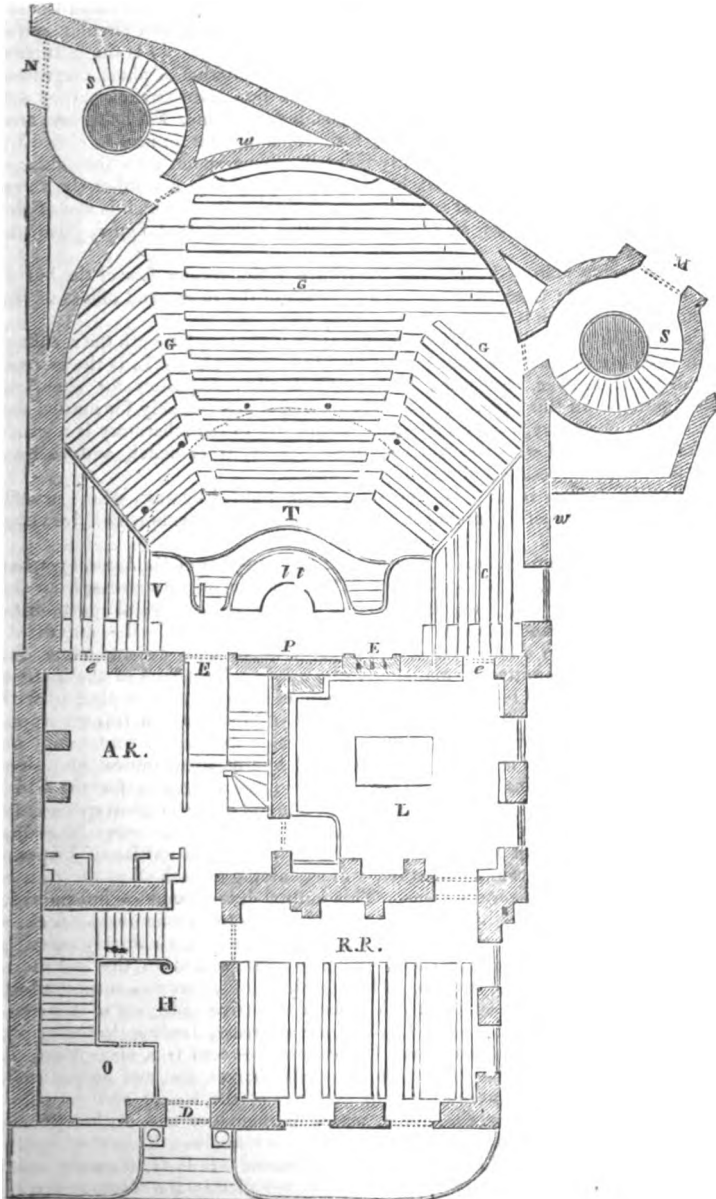
The front of this institution is a large dwelling-house, situated in Southampton Buildings, at the corner of Staple's Inn, in Holborn; the lower rooms of which are employed for the library, reading-rooms, apparatus rooms, laboratory, &c., and the upper as the private apartments of the Secretary. The theatre is an entirely new structure, built at the back of, and in connexion with, the house. The first stone of the theatre was laid on the 2d December, 1824, by Dr. Birkbeck, the munificent patron and enlightened president of the institution, and it was opened for use on the 8th of July, 1825.

The annexed *Fig. 1* exhibits a plan of the ground floor of the whole building, on a scale of 1 inch to 20 feet.

The doors in front of the house in Southampton Row are represented at D. O, office. H, hall and principal staircase. R R, reading-room for the accom-

dition of the members, supplied with all the periodical journals and reviews, and where all the books in the library may be perused. L, the library, containing upwards of 5000 volumes; including almost every work of reputation on

Fig. 1



science and literature, which may either be consulted in the reading-room, or taken home by the members. A R, ante-room to theatre. E, principal entrance from the house into theatre. *s e*, side-entrances into theatre. T, the theatre, bounded by a wall *w w w*, of a horse-shoe form. G G G are the seats appropriated to the members in general. C are those allotted exclusively to members of the committee; and V, those for the accommodation of honorary members, and visitors. N is the entrance into the theatre from Northumberland Court; and M is that leading from Middle Row, Holborn. S S, two circular spiral staircases, which proceed from the basement to the gallery. *l t* is the lecturers' table, behind which, at P, is a large frame for the exhibition of plans, diagrams, charts, drawings, &c.; and when these are made into transparencies, they are illuminated by a series of gas jets arranged behind the frame. F is a furnace, employed in the chemical lectures. This furnace, when not in use, is closed by two folding-doors, which are elegantly painted to correspond with the folding-doors of the entrance E. The six black spots arranged in a semi-circle, show the site of the iron pillars that support the principal gallery, which is also of the horse-shoe form, as shown by the curved dotted line of that figure, (also exhibited in *Fig. 2*.)

The foregoing plan, although only descriptive of the *ground-floor* of the building, will enable us to explain the appropriation of the rooms and offices of the basement underneath it.

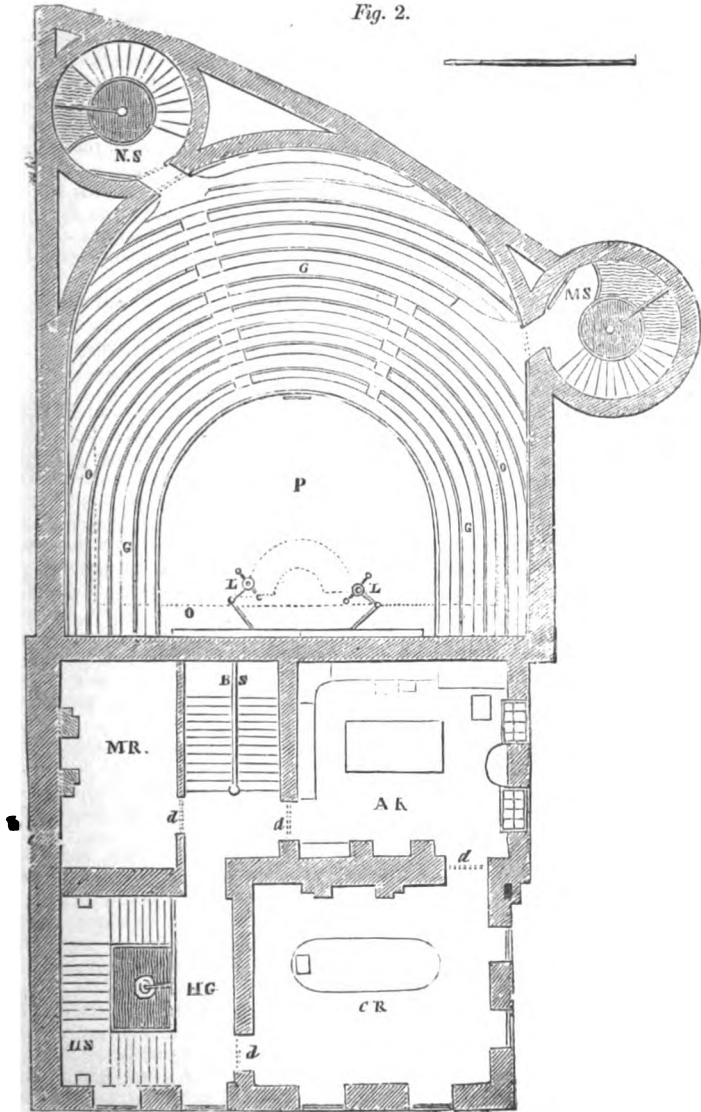
Underneath the hall H, is a kitchen and store-room; underneath the reading-room R R, are the porter's rooms; and underneath the library L, is the laboratory of the same area, containing furnaces, and other requisites for chemical investigations. In this room a class of the members meet weekly for mutual instruction in chemistry, mineralogy, &c. Adjoining to the laboratory is a small workshop, furnished with an excellent turning-lathe, work-bench, and various tools for the construction and repair of apparatus.

Under the theatre is an extensive class-room, lighted by gas, where practical geometry, perspective, architectural, mechanical, and ornamental drawing, are regularly taught.

The annexed figure (2.) exhibits a plan of the *first-floor of the house*, together with a plan of the gallery of the theatre. H S is the ascending staircase from the hall to the first-floor; H G, the gallery leading therefrom to the several apartments, all the doors or entrances to which are marked with *a d*. C R is the committee-room, furnished with a large table, and other requisites, to accommodate the meetings of the committee of managers, who conduct the affairs of the institution. This room is 19 feet by 21 feet, and one of the side-walls is covered with a glass case, furnished with a splendid collection of minerals. A R is the apparatus-room, or museum, furnished with glass cases around it, containing an extensive assortment of mechanical, pneumatical, hydrostatical, optical, and electrical apparatus; besides a great variety of very large diagrams, for the illustration of those subjects; and an assortment of mineral and geological specimens. This room is open for the accommodation of the members every Tuesday evening, from eight till ten o'clock, to afford them opportunities of inspecting the apparatus, conversing together, and explaining to each other the results of their experience and observations. This mutual interchange of information is calculated to be productive of important advantages to the members. A class for mutual instruction in experimental philosophy, also holds a weekly meeting in this room. M R is another room, similarly appropriated to the last mentioned; it contains various models, and large pieces of apparatus, inconvenient for exhibition in the museum, (A R,) and an extensive collection of transparent illustrations of various sciences. B S, the staircase, leading to the upper floors of the house. The room over the committee-room is a class-room, in which writing, drawing, the English and Latin languages, &c., and occasionally stenography, are taught in the different evenings of the week; and the room over the museum is also a class-room, where mathematics and arithmetic are taught. The other rooms in the upper part of the house are the private apartments of the secretary, who resides on the premises. G G G, show the seats in the gallery of the theatre, rising up an inclined plane; the front, or lowest

row, being upon a level with the first-floor of the house, and the highest, or back row, being about 17 feet above the lowest. N S is the top of the circular stone staircase leading from the entrance in Northumberland Court; and M S, that appertaining to the entrance from Middle Row, Holborn. P is the pit, or

Fig. 2.



rather ground-floor, of the theatre, the plan of which is given in Fig. 1. L L are two jointed branches for gas-lights, each containing three burners, which can be moved in various positions, to suit the objects to be illuminated. The

dotted lines *ooo*, show the plan of a lofty rectangular gallery, even with the top of the semi-circular gallery *G*, from which there are two entrances at the extremities, and another in the middle.

**THEODOLITE.** A mathematical instrument used by land-surveyors, for taking angles, distances, altitudes, &c. This instrument is variously made, and provided with subordinate apparatus, according to the price, or the requirements of the purchaser. We shall describe one of the most generally useful. This consists of two concentric horizontal circles, the inner of which has, at the ends of one of its diameters, two perpendicular columns, on which rests the horizontal axis of a small meridian telescope. The vernier of the inner circle is made fast to an arbitrary division line of the outer one, and both circles are moved, together with the telescope, until the object sought for appears in its field. The outer circle is now fixed, and the inner one is turned round, until the telescope strikes the second object, whose angular distance from the first is to be measured. The inner circle is now fastened to the outer, and by means of a micrometer screw, the thread of the telescope is brought exactly upon the object. The arc which the vernier of the inner circle has described on the outer one measures the angle which the two objects make at the common centre of the two circles.

**THEOREM.** A proposition which terminates in theory, and which considers the properties of things already made or done. Or, theorem is a speculative proposition, deduced from several definitions compared together.

**THEORY.** A doctrine which terminates in speculations, without any view to the practice or application of it.

**THERMOMETER.** An instrument for measuring the temperature of bodies; founded upon the principle of augmentation in volume of fluids, in proportion to their absorption of caloric; and as regards aeriform fluids, the principle is probably very correct: but solids, and still more liquids, expand unequally, by equal increments of heat. Thermometers were invented about the beginning of the seventeenth century; but a knowledge of their author is involved in some obscurity. For the first half century, after their introduction, they were made in a very rude and imperfect manner; but they were at length considerably improved by the Florentine academicians, and received subsequent ameliorations from Mr. Boyle, Dr. Halley, and Sir Isaac Newton, as well as from contemporaneous philosophers on the continent. The changes which the instrument underwent in their hands, (described in the *Oxford Encyclopædia*.) we shall not here insert, as all that had at that time been proposed, were liable to many inconveniences, and could not be considered as exact standards for pointing out the various degrees of temperature.

The thermometers which at present are in most general use, are Fahrenheit's, De l'Isle's, Reaumur's, and Celsius's. Fahrenheit's are used in Britain, De l'Isle's in Russia, Reaumur's, and the thermometer centigrade, in France, and Celsius's, the same as the last named, in Sweden. They are all mercurial thermometers.

Fahrenheit's thermometer consists of a slender cylindrical tube, and a small longitudinal bulb. To the side of the tube *a*, is annexed a scale *b*, which Fahrenheit divided into 600 parts, beginning with that of the severe cold which he had observed in Iceland in 1709, or that produced by surrounding the bulb *c* of the thermometer with a mixture of snow or beaten ice, and sal ammoniac, or sea salt. This he apprehended to be the greatest degree of cold; and accordingly he marked it, as the beginning of his scale, with 0; the point at which mercury begins to boil, he conceived to show the greatest degree of heat, and this he made the limit of his scale. The distance between these two points, he divided into 600 equal parts or degrees; and by trials, he found that the mercury stood at thirty-two of these divisions, when water just begins to freeze, or snow or ice just begins to thaw; it was, therefore, called the degree of the freezing point. When the tube was immersed in boiling water, the mercury rose to 212, which, therefore, is the boiling point, and is just 180 degrees above the former, or freezing point. But the present method of marking the scale of these thermometers, which is the sort in most common use,

is first to immerse the bulb of the thermometer in ice or snow just beginning to thaw, and mark the place where the mercury stands, with number 32; then immerse it in boiling water, and again mark the place where the mercury stands in the tube; which mark, with the number 212, exceeding the former by 180, dividing therefore the intermediate space into 180 equal parts, will give the scale of the thermometer, and which may afterwards be continued upwards or downwards at pleasure. Other thermometers of a similar construction have been accommodated to common use, having but a portion of the above scale. They have been made of a small size and portable form, and adapted with appendages to particular purposes; and the tube, with its annexed scale, has often been inclosed in another thicker glass tube, also hermetically sealed, to preserve the thermometer from injury.

In 1733, M. De l'Isle, of Petersburg, constructed a mercurial thermometer, on the principles of Reaumur's spirit thermometer. In his thermometer, the whole bulk of quicksilver, when immersed in boiling water, is conceived to be divided into 100,000 parts; and, from this one fixed point, the various degrees of heat, either above or below it, are marked in these parts on the tube or scale, by the various expansion or contraction of the quicksilver, in all imaginable varieties of heat.

The thermometer at present used in France is called Reaumur's, but it is very different from the one originally invented by Reaumur in 1730, in which spirits of wine was used to indicate the degrees of expansion. The thermometer now in use in France is filled with mercury; and the boiling-water, which is at 80, corresponds with the 212th degree of Fahrenheit. The scale, indeed, commences at the freezing point, as the old one did. The new thermo-

meter ought more properly to be called De Luc's thermometer, for it was first made by De Luc. When De Luc had finished the scale, and completed an account of it, he showed the manuscript to M. De la Condamine. Condamine advised him to change the number 80; remarking, that such was the inattention of physicians, that they would probably confound it with Reaumur's. De Luc's modesty, as well as a predilection for the number 80, founded, as he thought, on philosophical reasons, made him decline following this advice; but he found by experience, that the prediction of Condamine was too well founded. The thermometer of Celsius, which is used in Sweden, has a scale of 100 degrees from the freezing to the boiling-water point.

The *thermometer centigrade*, now used in France, has the scale divided in the same way. Many other thermometers have been used besides these, and consequently observations taken by them; but it is unnecessary to describe any of these more minutely, as they are no longer used. Those who wish to read a more particular account of them may consult Dr. Martine's *Essays*. It must be admitted that disadvantages attend the adoption of the scales of each of the thermometers we have described, but hitherto the sanction of long usage in the countries where they have been introduced, has prevented their being superseded by any other.

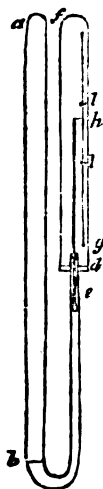
A self-registering thermometer has been invented by Mr. Keith, of Ravelstone, which is considered as most ingenious and simple. *a b*, in the annexed figure, is a thin glass tube, about fourteen inches long, and three-fourths of an inch calibre, close or hermetically sealed at top. To the lower end, which is open, there is joined the crooked glass tube *b e*, seven inches long, and four-tenths of an inch calibre, and open at top. The tube *a b* is filled with the strongest spirit of wine, and the tube *b e* with mercury. This is properly a spirit-of-wine thermometer, and the mercury is used merely to support a piece of ivory, or glass, to which is affixed a wire for raising one index, or depressing another, according as the mercury rises or falls. *E* is a small conical piece of ivory or glass, of such a weight as to float on the surface of the mercury. To the float is joined a wire, called the float-wire, which reaches upwards to *H*,



*Correspondence of the Thermometers of FAHRENHEIT and REAUMUR, and that of CELSIUS, or the Centigrade Thermometer of the modern French Chemists.*

Fahr.	Reaum.	Celsius.	Fahr.	Reaum.	Celsius.	Fahr.	Reaum.	Celsius.	Fahr.	Reaum.	Celsius.	Fahr.	Reaum.	Celsius.
212	80.	100.	161	57.3	71.6	110	34.6	43.3	59	12.	15.	8	10.6	13.3
211	79.5	99.4	160	56.8	71.1	109	34.2	42.7	58	11.5	14.4	7	11.1	13.8
210	79.1	98.8	159	56.4	70.5	108	33.7	42.2	57	11.1	13.8	6	11.5	14.4
209	78.6	98.3	158	56.	70.	107	33.3	41.6	56	10.6	13.3	5	12.	15.
208	78.2	97.7	157	55.5	69.4	106	32.8	41.1	55	10.2	12.7	4	12.4	15.5
207	77.7	97.2	156	55.1	68.8	105	32.4	40.5	54	9.7	12.2	3	12.8	16.1
206	77.3	96.6	155	54.6	68.3	104	32.	40.	53	9.3	11.6	2	13.3	16.6
205	76.8	96.1	154	54.2	67.7	103	31.5	39.4	52	8.8	11.1	1	13.7	17.2
204	76.4	96.5	153	53.7	67.2	102	31.1	38.8	51	8.4	10.5	0	14.2	17.7
203	76.	95.	152	53.3	66.6	101	30.6	38.3	50	8.	10.	1	14.6	18.3
202	75.5	94.4	151	52.8	66.1	100	30.2	37.7	49	7.5	9.4	2	15.1	18.8
201	75.1	93.8	150	52.4	65.5	99	29.7	37.2	48	7.1	8.8	3	15.5	19.4
200	74.6	93.3	149	52.	65.	98	29.3	36.6	47	6.6	8.3	4	16.	20.
199	74.2	92.7	148	51.5	64.4	97	28.8	36.1	46	6.2	7.7	5	16.4	20.5
198	73.7	92.2	147	51.1	63.8	96	28.4	35.5	45	5.7	7.2	6	16.8	21.1
197	73.3	91.6	146	50.6	63.3	95	28.	35.	44	5.3	6.6	7	17.3	21.6
196	72.8	91.1	145	50.2	62.7	94	27.5	34.4	43	4.8	6.1	8	17.7	22.2
195	72.4	90.5	144	49.7	62.2	93	27.1	33.8	42	4.4	5.5	9	18.2	22.7
194	72.	90.	143	49.3	61.6	92	26.6	33.3	41	4.	5.	10	18.6	23.3
193	71.5	89.4	142	48.8	61.1	91	26.2	32.7	40	3.5	4.4	11	19.1	23.8
192	71.1	88.8	141	48.4	60.5	90	25.7	32.2	39	3.1	3.8	12	19.5	24.4
191	70.6	88.3	140	48.	60.	89	25.3	31.6	38	2.6	3.3	13	20.	25.
190	70.2	87.7	139	47.5	59.4	88	24.8	31.1	37	2.2	2.7	14	20.4	25.5
189	69.7	87.2	138	47.1	58.8	87	24.4	30.5	36	1.7	2.2	15	20.8	26.1
188	69.3	86.6	137	46.6	58.3	86	24.	30.	35	1.3	1.6	16	21.3	26.6
187	68.8	86.1	136	46.2	57.7	85	23.5	29.4	34	0.8	1.1	17	21.7	27.2
186	68.4	85.5	135	45.7	57.2	84	23.1	28.8	33	0.4	0.5	18	22.2	27.7
185	68.	85.	134	45.3	56.6	83	22.6	28.3	32	0.	0.	19	22.6	28.3
184	67.5	84.4	133	44.9	56.1	82	22.2	27.7	31	0.4	0.5	20	23.1	28.8
183	67.1	83.8	132	44.4	55.5	81	21.7	27.2	30	0.8	1.1	21	23.5	29.4
182	66.6	83.3	131	44.	55.	80	21.3	26.6	29	1.3	1.6	22	24.	30.
181	66.2	82.7	130	43.5	54.4	79	20.8	26.1	28	1.7	2.2	23	24.4	30.5
180	65.7	82.2	129	43.1	53.8	78	20.4	25.5	27	2.2	2.7	24	24.8	31.1
179	65.3	81.6	128	42.6	53.3	77	20.	25.	26	2.6	3.3	25	25.3	31.6
178	64.8	81.1	127	42.2	52.7	76	19.5	24.4	25	3.1	3.8	26	25.7	32.2
177	64.4	80.5	126	41.7	52.2	75	19.1	23.8	24	3.5	4.4	27	26.2	32.7
176	64.	80.	125	41.3	51.6	74	18.6	23.3	23	4.	5.	28	26.6	33.3
175	63.5	79.4	124	40.8	51.1	73	18.2	22.7	22	4.4	5.5	29	27.1	33.8
174	63.1	78.8	123	40.4	50.5	72	17.7	22.2	21	4.8	6.1	30	27.5	34.4
173	62.6	78.3	122	40.	50.	71	17.3	21.6	20	5.3	6.6	31	28.	35.
172	62.2	77.7	121	39.5	49.4	70	16.8	21.1	19	5.7	7.2	32	28.4	35.5
171	61.7	77.2	120	39.1	48.8	69	16.4	20.5	18	6.2	7.7	33	28.8	36.1
170	61.3	76.6	119	38.6	48.3	68	16.	20.	17	6.6	8.3	34	29.5	36.6
169	60.8	76.1	118	38.2	47.7	67	15.5	19.4	16	7.1	8.8	35	29.7	37.2
168	60.4	75.5	117	37.7	47.2	66	15.1	18.8	15	7.5	9.4	36	30.2	37.7
167	60.	75.	116	37.3	46.6	65	14.6	18.3	14	8.	10.	37	30.6	38.3
166	59.5	74.4	115	36.8	46.1	64	14.2	17.7	13	8.4	10.5	38	31.1	38.8
165	59.1	73.8	114	36.4	45.5	63	13.7	17.2	12	8.8	11.1	39	31.5	39.4
164	58.6	73.3	113	36.	45.	62	13.3	16.6	11	9.3	11.6	40	32.	40.
163	58.2	72.7	112	35.5	44.4	61	12.8	16.1	10	9.7	12.2			
162	57.7	72.2	111	35.1	43.8	60	12.4	15.5	9	10.2	12.7			

where it terminates in a knee bent at right angles. The float-wire, by means of an eye at *h*, moves easily along the small harpsichord wire *g h*. *l l* are two indexes made of thin black oiled silk, which slide upwards or downwards with a force of not more than two grains. The one placed above the knee points out the greatest rise, and the one placed below it points out the greatest fall, of the thermometer. When the instrument is to be prepared for an observation, both indexes are to be brought close to the knee *h*. It is evident, that when the mercury rises, the float and float-wire, which can be moved with the smallest force, will be pushed upwards till the mercury becomes stationary. As the knee of the float-wire moves upwards, it will carry along with it the upper index *l*. When the mercury again subsides, it leaves the index at the highest point at which it was raised, for it will not descend by its own weight: as the mercury falls, the float-wire does the same; it therefore brings along with it the lower index *l*, and continues to depress it till it again becomes stationary, or ascends in the tube; in which case it leaves the lower index behind it, as it had formerly left the upper. The scale to which the indexes point is placed parallel to the slender harpsichord wire. That the scale and indexes may not be injured by the wind and rain, a cylindrical glass cover, close at top, and made so as exactly to fit the part *g f*, is placed over it.



As a knowledge of the correspondence between the thermometers of Fahrenheit, Reaumur, and Celsius, are indispensable to the comprehension of the scientific labours of the French and German philosophers and authors, whether in the original languages, or the English translations, we have inserted a table in which the degree of any given temperature under  $212^{\circ}$  of Fahrenheit is expressed by those of Reaumur and Celsius: we omit De Lisle's, its use being confined to Russia. As, however, higher degrees of temperature may be required than those given in the table, the following rules are given for changing the degrees of any one of the scales into equivalent degrees of another; viz. each degree of Fahrenheit is equal to four-ninths of one of Reaumur; as Reaumur, however, reckons his degrees from the freezing point, and Fahrenheit  $32^{\circ}$  below this point, we must, when the number of Fahrenheit's degrees to be reduced indicate a temperature above the freezing-point, first deduct 32, then multiply the remainder by 4, and divide the product by 9. The quotient is the corresponding number of degrees on Reaumur's scale. If the temperature indicated was less than the freezing point, we must also be careful to take the actual number of degrees, reckoning from the freezing point. Thus 4 degrees above Fahrenheit's zero is 28 below his freezing point; and this is the number to be reduced to Reaumur's scale.

Each degree of Reaumur is equal to  $2\frac{1}{4}$  of one of Fahrenheit. Multiply the given number of degrees of Reaumur by 9, and divide the product by 4. If the degrees of Reaumur were minus, the quotient must be deducted from 32, and the remainder will be the equivalent degrees of Fahrenheit. If the given degrees were not minus, the quotient must be added to 32 degrees, and the sum will be the equivalent sought.

Each degree of Fahrenheit is equal to  $\frac{1}{4}$  of one of the centigrade. Proceed as in the case of Fahrenheit and Reaumur, multiplying, however, by 5, and dividing by 9.

Each degree of Reaumur is equal to  $1\frac{1}{4}$  of the centigrade. Multiply the given number of degrees by 5, divide the product by 4, and the quotient will be the equivalent number of degrees on the centigrade scale.

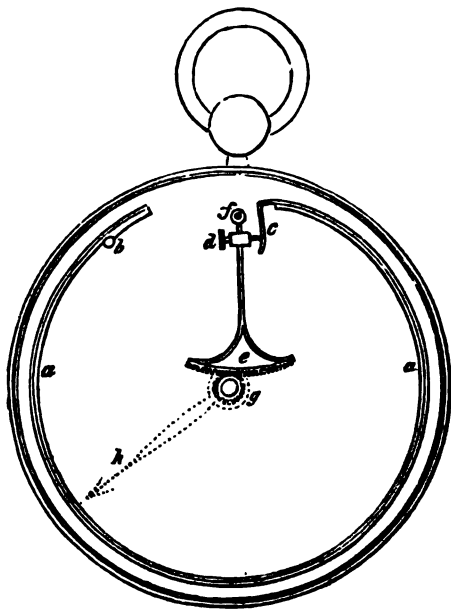
Each degree of the centigrade scale is equal to four-fifths of Reaumur. Multiply the given number of degrees of the centigrade by 4, and divide the product by 5; the quotient will be the equivalent number of degrees on Reaumur's scale.

The different degrees of expansibility of dissimilar metals by the same increase of temperature, is well known, and has been usefully employed to produce compensation in the regulators of time-keepers; and recently a very sensible and convenient thermometer has been made on the same principle.

The one from which we made the diagram on the next page, is contained in a common-sized pocket-watch, and indicates the temperature from 30° below zero to 80° Reaumur, equal to the extent from zero, to 212° on Fahrenheit's scale.

It consists of a slip of steel on a slip of brass attached together, and bent with the brass inwards, into a circular form *a a*, and fixed to the frame of the watch at *b*, immediately behind the dial. One end of this circular piece is bent inwards at *c*, and acts upon a lever, *e f*, of the third order. The lever moves upon a pivot at *f*, is furnished with an adjusting screw *d*, and a toothed segment *e*. The teeth of this segment act upon the teeth of a small pinion *g*, to the projecting pivot of which an index *h* is attached.

The action of this little instrument is obvious; for as the interior portion of the compound circular piece is of brass, which is more expansible than the exterior, which is of steel, an increase of heat will cause the ring to open; but in opening it acts upon the lever, and by that means turns the index, which points out by the graduated circle on the face of the watch the quantity of increase. On the contrary, when a decrease of heat takes place, the ring will have a tendency to close, and the lever being kept up to it by a small spring on the opposite side, acts upon the index, and points the quantity of decrease in the temperature. This thermometer indicates a change of temperature much quicker than the common mercurial thermometer, owing to the metals being better conductors of caloric, than wood or glass, the substances of which they are usually manufactured.



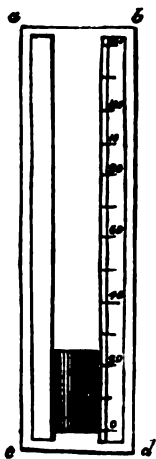
A *Thermometer of Contact* has lately been invented by M. Fourrier. "It is well known," says M. Fourrier, "that on touching different substances maintained at the same temperature, the same calorific impression is not received in consequence of the different conductivity of those bodies. It is even sufficient to cover those bodies with a thin sheet of paper, sensibly to change the effect of the contact. If, then, on a support kept at a constant

temperature, for example, at that of melting ice, thin sheets of different substances are successively applied, the simple contact of the naked hand will suffice to class a great number of them according to their order of conductivity; but this method is by no means accurate, and is liable to other inconveniences. M. Fourier's instrument may be considered as an improved hand, and minutely establishes the facts to which the application of the hand only makes an approximation. It is extremely simple; it consists of a cone of very thin iron, filled with mercury, and terminated at its circular base by a skin of moderate thickness. A thermometer is placed in the mercury; it is this skin which is put on the thin sheet applied to the support. The contact is very intimate, in consequence of its flexibility; and the thermometer indicates the variations of temperature. By this instrument many curious facts have already been ascertained. For instance, it has been shown, that the order in which thin sheets of different substances are placed one upon another, influences the quantity of heat which passes through them under the same external circumstances. Thus, the interposition of a sheet of leather facilitates the transmission of heat from skin to cloth, and it obstructs it from cloth to marble.

The thermometers hitherto described are very limited in their extent; they indeed point out to us the lowest degrees of heat which are commonly observed even in cold climates, but they by no means reach to those degrees of heat which are very familiar to us. The mercurial thermometer extends no farther than to 600 of Fahrenheit's scale, the heat of boiling mercury; but we are sure that the heat of solid bodies, when heated to ignition, or till they emit light, far exceeds the heat of boiling mercury. In order to remedy this defect, Sir Isaac Newton attempted, by an ingenious experiment, to extend the scale to any degree required. His plan, however, was not found convenient for practical purposes. But following the idea suggested by Newton, the late Mr. Wedgwood invented a very simple thermometer, which marks with much precision the different degrees of ignition from a dull red heat visible in the dark, to the heat of an air-furnace.

*a b c d*, in the annexed figure, is a smooth flat plate; on which are fixed two rulers, or flat pieces, a quarter of an inch thick, lying flat upon the plate, with the sides that are towards one another made perfectly true, a little further asunder at one end, than at the other end; thus they include between them a long converging canal, which is divided on one side into a number of small equal parts, and which may be considered as performing the offices both of the tube and scale of the common thermometer. It is obvious, that if a body, so adjusted as to fit exactly at the wider end of this canal, be afterwards diminished in its bulk by fire, as the thermometer pieces are, it will then pass further into the canal, and more and more so according as the diminution is greater; and conversely, that if a body so adjusted as to pass on to the narrow end, be afterwards expanded by fire, as is the case with metals, and applied in that expanded state to the scale, it will not pass so far; and that the divisions on the side will be the measures of the expansions of the one, as of the contractions of the other, reckoning in both cases from that point to which the body was adjusted at first. *i* is the body whose alteration of bulk is thus to be measured. This is to be gently pushed or slid along towards the narrow end till it is stopped by the converging sides of the canal. Mr. Walker, to whom we have already alluded, suggests the idea of a metallic thermometer which shall embrace the medium between the highest point of the mercurial thermometer, which terminates at 600 degrees, and the lowest of Wedgwood's, just described, which commences at 1077 degrees of Fahrenheit.

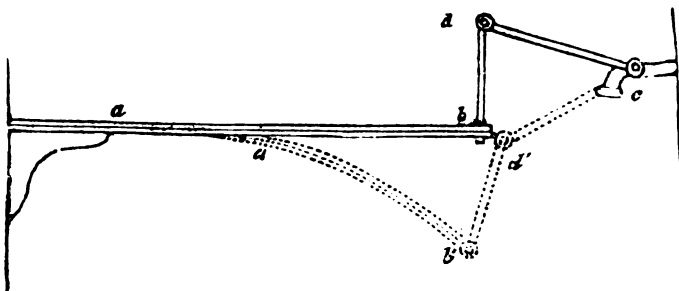
A metallic composition is formed, not liable to alteration in its quality or quantity by repeated exposure to heat, the melting point of which is at a little below 600 degrees of Fahrenheit, and its boiling point at 1200 degrees. A case resembling in form the glass case for the ordinary thermometer, but somewhat



larger, contains the metallic composition, and the scale consists in a slender graduated rod, equal in height at the commencement of the scale; that is, when the metallic composition is just liquid to the top of the tube, the graduated rod terminating at the bottom in a thin, circular, flat plate, which rests or floats as it were upon the liquid metal; and in proportion as the latter expands and rises in the tube by heat, the graduated rod is buoyed up, or raised above the top of the tube, passing through a perforated cover to the maximum, or boiling point. The thermometer case and graduated rod are formed of pipe-makers' clay, previously prepared by having been exposed to a sufficient degree of heat. The scale of this new thermometer is an exact continuation of the scale in the mercurial thermometers; the lower degrees of the former corresponding with, or indicating like, temperatures with the upper degrees of the mercurial thermometer.

"The same principle," says Mr. Walker, "I might observe, admits of being extended, for the purpose of ascertaining the variation in temperature, up to the most intense heat, perhaps, that can be required. It is unnecessary to state here, that the influence of the incumbent atmosphere upon the surface of the liquid metal within the open tube is too inconsiderable, even at the commencement of the scale, to deserve notice, and at a higher temperature diminishes to nothing; especially if the whole of the liquid contained in the thermometer, as ought to be the case in every thermometer, be completely immersed, or subjected to the temperature, the degree of which it is intended to indicate. A method similar to the above, I should think, might be applicable to the purpose of showing, in a ready way, the degree of expansion in metals by heat; but the elongation of a cylinder of any metal, by increase of temperature, is much too small to admit of its being a convenient measure of temperature. I should not despair, however, availing myself of every advantage, viz., increasing the length of a metallic wire, by giving it a spiral form, in order to comprise a considerable length in small compass, with the application of the lever-index, and a good magnifier, upon constructing a thermometer upon this principle, so as to render the scale apparent even to single degrees; using silver for the lower temperatures, and platina for the higher, or employing iron wire, only up to its ultimate point of expansion in a solid state.

**THERMOSTAT.** The name given to an instrument invented and recently patented by Dr. Ure, for regulating temperature in vaporization, distillation, and other processes, in which the agency of heat is required. It is effected by increasing or diminishing the size of the apertures through which the calorific medium is transmitted. The nature of the contrivance, and its mode of action, will be understood by reference to the annexed diagram.



*a b*, represent a compound bar, composed of two flat pieces of metal, possessing different powers of expansibility by the same increase of temperature, such as iron and zinc, firmly rivetted together. Now, suppose the most expansible metal, the zinc, placed on the upper side, the compound bar will bend downwards to the position represented at *a' b'*; and by diminution of the temperature below that at which the metals were rivetted together, a flexure in the con-

rary direction would take place ; and thus a motion is obtained from any change of temperature, which may be made, through the medium of levers, available in checking the cause of change, by altering the size of the opening through which the change was effected. Let  $c$  represent a stop-cock, through which steam, hot water, or other fluid enters, to communicate heat to the vessel containing the thermostat  $a b$ , and let  $c d$  be a lever or handle, by which the cock is turned, joined to the compound bar, by the connecting-rod  $d b$  ; also, let the plug or the cock be so adjusted, that it shall be partially open when the lever is in the position represented by  $c d$  ; and less open when in the position represented by  $c d'$  ; then it is evident, that any increase of temperature, beyond that to which the instrument may have been adjusted, would, by causing the instrument to bend downwards, immediately diminish the passage, and consequently the supply of steam, hot water, or whatever fluid may be used for communicating heat. While, on the contrary, a diminution in the temperature would cause the bar to bend upwards, and thus increase the passage for the admission of a greater quantity of the heating vapour or fluid.

The patentee gives a variety of examples, of the application of his thermostat for regulating the admission of heating fluids, as well as for regulating the ventilation of rooms, public buildings, &c., some of them displaying considerable ingenuity ; but they all depend upon the principle above explained, and therefore we have not deemed it necessary to describe them.

**THIMBLE.** A metallic case, worn by tailors and sempstresses upon the finger, for the purpose of pressing needles through the stuff in sewing. An instrument, answering the same purpose, is worn by sailors and sail-makers in the palms of their hands by straps which fasten it thereto ; they are technically called palms, and are small circular plates of cast iron, indented on the surface. Thimble is the name also given to circular rings of iron, hollow on the outside, for a rope which envelopes it to be securely imbedded therein ; a metallic eye is thus formed, for passing another rope through, or hanging on to it by a hook, a tackle block, &c.

**THRESHING-MACHINE.** An apparatus for separating the grain from the straw. Machines for this purpose were contrived as far back as 1732 ; these were considerably improved by Mr. Andrew Meikle, in 1785, who took a patent for his improvements, which are described in the "Repertory of Arts." Since that time they have undergone various ameliorations ; and the construction of those which are mostly employed at the farm-houses, may be briefly described as consisting of three rotative drums or cylinders ; around the first which comes into operation are a series of arms, or beaters, which are made to revolve, and thereby strike the corn (supplied underneath them by feeding rollers,) with great rapidity. Hence the threshed corn is carried on by the motion of the feed rollers, to two successive straw shakers, which consist (as before mentioned) of a rotative frame, armed with numerous spikes, that lift up and shake the straw, so as to force from amongst it the grain, and allow it to fall through a grated floor, into a large hopper beneath. From this hopper the corn is conducted to another receptacle, and in its passage winnowed by fanners driven with great velocity, that separate the chaff, by blowing it away into another receptacle. Of course the power by which such machines are driven depends upon local circumstances ; but in general a horse-wheel is employed, worked by the united force of three horses ; the horse-wheel is mounted with a large horizontal wheel, which drives a pinion on the main shaft of the threshing-machine ; and the main shaft, by suitable gear, gives motion at the requisite velocities to the parts we have described.

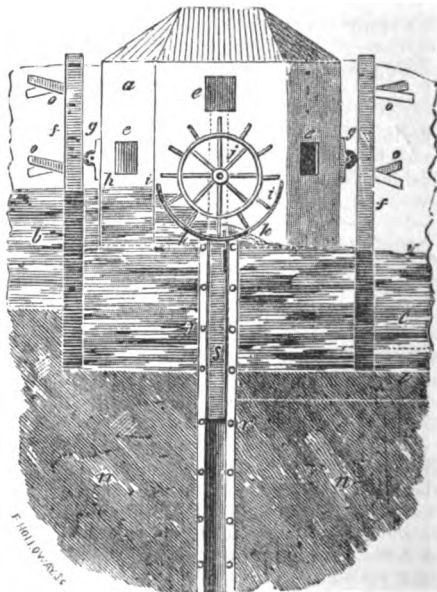
**TIDE.** A regular periodical current of water, setting alternately in a flux and reflux, and generally considered to be produced by the influence of the moon. The sagacious Locke, in describing the theory of the tides, observes, "that motion of the water called the tides, is a rising and falling of the sea ; the cause of this is the attraction of the moon, whereby the part of the water in the great ocean, which is nearest the moon, being most strongly attracted, is raised higher than the rest ; and these two opposite elevations of the surface of the water in the great ocean, following the motion of the moon from east to west, and striking against the large coasts of the continents, from thence rebound back again, and so make floods and ebbs in narrows, seas, and rivers.

**TIDE-MILLS.** Are mills or any kind of machinery moved by the ebbing and flowing of the tide. Mills of this kind are not very common, on account of the great expense of their construction; but in situations where the tide rises to a considerable height, and where the fuel required for a steam-engine is high, and the first cost can be met, tide-mills may be very advantageously constructed.

The origin of tide-mills in this country does not appear to be recorded; but the able Belidor ascribes the invention to a master-carpenter, at Dunkirk, of the name of Perse. Mills to be worked by the rising or falling of the tide, admit of great variety in the essential parts of their construction; but this variety, Dr. Gregory observes, may be reduced to four general heads, according to the manner of action of the water-wheel. 1st, the water-wheel may turn one way when the tide rises, and the contrary when it falls. 2d, the water-wheel may be made to turn always in one direction. 3d, the water-wheel may rise and fall, as the tide ebbs and flows. 4th, the axle of the water-wheel may be so fixed as that it shall neither rise nor fall, though the rotary motion shall be given to the wheel, while at one time it is only partly, at another completely immersed in the fluid.

Some very ingenious suggestions for the construction of a tide-mill appeared some time since in a scientific journal, in which the arrangements differ in some essential respects from those apparently contemplated in Dr. Gregory's classification. We shall insert the description in the author's own words,

*Fig. 1.*



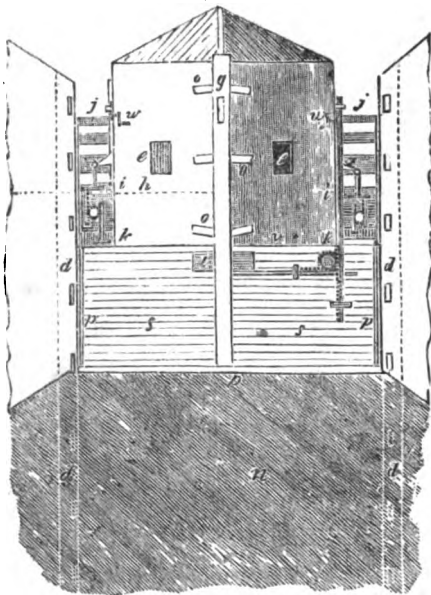
In this plan, "the water is compelled to flow in and out of a basin, in such a manner, that the greatest force shall be obtained from its current, and the annexed diagrams are introduced to illustrate the following explanation."

*Fig. 1* represents a perpendicular projection of the principal parts on a plane, supposed to be drawn longitudinally and vertically through the centre of the work. *h v* show the respective heights of the water, on each side of the flood-gate *s*; the flushes, *i* on *b*'s side, and *k* on *c*'s, are supposed to be open, and

according to the nomination of the parts, the water is flowing from the basin into the sea.

Fig. 2 represents a perpendicular projection of the principal parts on a plane, supposed to be drawn latitudinally and vertically through the centre of the

Fig. 2.



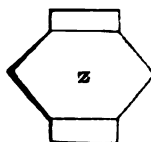
work. *h* shows the level of the water when flowing from the represented side; the position of the flushes under these circumstances are shown, *i* being open, and *k* closed; *v* shows the level; *vice versa*, the position of the flushes in this case are seen, *i* being closed, and *k* open. An objection may arise from the variation of the quantity of water at the spring and neap tides. To counteract this, the flush *l* is introduced into the flood-gate *s*, which may be opened and closed according as there is a redundancy or deficiency of water: this may either be effected by centrifugal balls, or by the attention of the individual who takes care of the works. It should be entirely opened when the mill is not used.

Although this plan is more particularly adapted for harbours and the tideway of rivers, yet there are few parts of the coast on which such a mill might not be constructed. If it be on a sandy beach, a large wooden tunnel should be laid down at the lowest tide level, in order to introduce water upon the flood-gate. The basin had better be constructed of wood, as then the sides of it may be vertical, which is of great advantage, to produce a less variable current; but it may be excavated, and lined with clay, which should be covered over with shingles, in order to prevent the clay from being washed off. If it be on a rocky coast, and as before exposed to a surf, there should be a small tunnel excavated, (as shown by dotted lines at *t*.) The basin in this case is easily formed; I conjecture that an excavation of the capacity of one of our first-rate ships, and about 12 feet deep, would contain water enough to two pair of stones for a grist-mill.

*a* is the floating mill, of which the form of a ground plan is as Fig. 2. It



has angular ends for two reasons; 1st, because the building may be more easily constructed in this manner, to bear the pressure on the sheaves *gg*; and 2dly, in order to give a proper direction to the water. *b* is the excavated basin; *c* the sea or harbour; *s* the soil; *s* the flood-gate attached to the mill, and moving up and down with the tide; *j*, the water-wheel; *i i* flushes for introducing water on the wheel; *k k* ditto, for letting it off; *l* ditto, for regulating the influx of water according to the strength of the tide; *d*, the channel cut in the sides of the wall, and sunk below low-water mark, according to the rise and fall of the tide above, into which are inserted small sheaves working on an iron plate placed on the flood-gate, in order to reduce the friction; *ff* are vertical beams of timber, supported by pieces *o o*, thrown across the passage horizontally and diagonally, with respect to the beam itself, for the purpose of bearing the horizontal pressure of the building on the sheaves *g g*, which pressure takes place on each beam alternately, with the rise and fall of the tide; *e e* are doors, the upper one may receive the corn or materials when the mill is at a proper level, and the lower one discharge the same when in a convenient situation; leather is placed in the joints, in such a manner as to prevent the water from getting through between the slide and flood-gate. There are two water-wheels, in order that the pressure on the grooves *d d* may be less partial.



A tide-mill was erected at East Greenwich, on the right bank of the Thames, under the direction of Mr. John Lloyd, an engineer of Westminster, of which the following will convey an idea: the details are given by Dr. Gregory in his *Mechanics*, vol. ii.

This mill is intended to grind corn, and works eight pair of stones. The side of the mill-house parallel to the course of the river, measures 40 feet within; and as the whole of this may be opened to the river by sluice-gates, which are carried down to the low-water mark in the river, there is a 40 feet water-way to the mill; through the water-way the water presses during the rising tide into a large reservoir, which occupies about four acres of land; and beyond this reservoir is a smaller one, in which water is kept, for the purpose of being let out occasionally at low water to cleanse the whole works from mud and sediment, which would otherwise, in time, clog the machinery.

The water-wheel has its axle in a position parallel to the side of the river, that is, parallel to the sluice-gates which admit water from the river; the length of this wheel is 26 feet, its diameter 11 feet, and its number of float-boards 32. These boards do not each run on in one plane from one end of the wheel to the other, but the whole length of the wheel is divided into four equal portions, and the parts of the float-boards belonging to each of these portions fall gradually one lower than another, each by one-fourth of the distance, from one board to another, measuring on the circumference of the wheel.

This contrivance is intended to equalize the action of water upon the wheel, and prevent its moving by jerks. The wheel, with its incumbent apparatus, weighs about 20 tons, the whole of which is raised by the impulse of the flowing tide, when admitted through the sluice-gates. It is placed in the middle of the water-way, leaving a passage on each side of about six feet, for the water to flow into the reservoir, besides that which, in its motion, turns the wheel round. Soon after the tide has risen to the highest, (which at this mill is often 20 feet above the low water-mark,) the water is permitted to run back again from the reservoir into the river, and by this means it gives a rotary motion to the water-wheel in a contrary direction to that with which it moved when impelled by the rising tide.

**TILES.** Plates of red earthenware, used for the coverings of buildings, also for paving and other purposes. They are made of the better kind of brick-maker's clay, washed free from stones and other foreign matter; then moulded of various forms according to the purposes required, and baked in kilns.

**TILLER.** The bar or lever employed to turn the rudder in floating vessels, for the purpose of steering.

**TILT.** The awning or canopy spread over boats, waggons, and other equipages.

**TILT-HAMMER.** A large heavy hammer, worked by machinery. See **IRON.**

**TIME.** According to Mr. Locke, is "the measure of duration." "We acquire our notions of time," says Dr. Robison, "by our faculty of memory, in observing the succession of events. Time is conceived by us as unbounded, continuous, homogeneous, unchangeable in the order of its parts, and divisible without end. The boundaries between successive portions of time may be called instants, and minute portions of it may be called moments. Time is conceived as a proper quantity, made up of, and measured by, its own parts. In our actual measurements we employ some event, which we imagine always to require an equal time for its accomplishment; and this time is employed as a unit of time or duration, in the same manner as we employ a foot-rule as a unit of extension. As often as this event is accomplished during some observed operation, so often do we imagine that the time of the operation contains this unit. It is thus that we affirm that the time of a heavy body falling 144 feet is thrice as great as the time of falling 16 feet; because a pendulum, 39 $\frac{1}{2}$  inches long, makes three vibrations in the first case, and one in the last." "There is an analogy," says our learned author, "between the affections of space and time, so obvious, that in most languages the same words are used to express the affections of both. Hence it is that time may be represented by lines, and measured by motion; for uniform motion is the simplest succession of events that can be conceived." This further analogy also occurs between time and space, namely, that as in space all things are placed in the order of situation, so in time all events occur in the order of succession. (See *Elements of Mechanical Philosophy*, by John Robison, LL.D., Vol. I.) Like place, time may also be distinguished into absolute and relative. *Absolute time* is time considered in itself, without any relation to bodies or their motions. *Relative, or apparent time*, is the sensible measure of any duration by means of motion. Time is also astronomical, or civil. *Astronomical time* is that of which the computation and measure depend solely on the motion of the heavenly bodies. *Civil time* is astronomical time modified, and accommodated to the purposes of civil life.

**TIME-KEEPER.** An instrument for measuring time. See **HOROLOGY.**

**TIN.** A metal of a white colour, intermediate between silver and lead. It is considerably harder than lead; scarcely at all sonorous; very malleable, being capable of extension, under the hammer, to about a two-thousandth part of an inch in thickness. The ordinary tinfoil is about a one-thousandth part of an inch thick. Tin has a slight unpleasant taste, and emits a peculiar smell when rubbed. Specific gravity, 7.291. It is very flexible, producing a remarkable crackling noise when bended, the loudness of which is a common, though not very accurate test of its purity. Tin melts at 442° Fahr.; when fresh cast, or fresh scraped, it is very brilliant, but it gradually loses its lustre by exposure to the air, and acquires a greyish-white tint, which does not sensibly change. Like lead, when heated nearly to fusion, it is brittle, and may be easily broken up by a hammer, when it exhibits a grained or fibrous texture. It may also be reduced to powder by agitation, at the period of its transition from the solid to the fluid state.

There are several kinds or qualities of tin. The Cornish block tin is usually in blocks of about three cwt. each; which are, however, run into smaller masses, of 30 or 40 lbs. each, for the convenience of trade. The common block tin is contaminated with a minute quantity of other metals, generally copper, to the extent of about a thousandth part. "Refined block-tin" is in blocks of tin melted into long narrow sticks, of a few ounces each. The "grain tin" is the purest of the several English kinds, being obtained from the pure oxide of tin of the steam-works of Cornwall. It is first cast into blocks of about 120 lbs. each, and afterwards melted, so as to separate it into fragments resembling rocks; which is produced by letting the metal fall, when barely fluid, from a great height. The tin imported from the East Indies, particularly Malacca, is esteemed very pure, and considered the best for organ pipes, and some other uses.

The tin ore of Cornwall, obtained from the mines, is stamped to reduce it into fragments, then washed, to separate the earthy matter, and afterwards roasted in a reverberating furnace; which process is repeated until the assay shows it to contain at least half of its weight of metal, when it is sold to the smelters. In this state it is mixed with culm and slaked lime, well moistened, and then smelted in a reverberating furnace, capable of reducing about 7 cwt. at a time. A given weight of tin, produced from Cornish ore, consumes about double its weight of coal in the operations of roasting and smelting. Between three and four thousand tons of tin are produced annually from the mines of Cornwall. Chaptal says, that if tin be kept in fusion in a lined crucible, and the surface be covered with a quantity of charcoal, to prevent its calcination, the metal becomes whiter, more sonorous, and harder, provided the fire be kept up for eight or ten hours.

Mercury dissolves tin with great facility, and in all proportions. To make this combination, heated mercury is poured on melted tin; the consistence of the amalgam differs according to the relative proportions of the two metals.

Nickel, united to tin, forms a white and brilliant mass. Half a part of tin, melted with two parts of cobalt, and the same quantity of muriate of soda, furnished Beaume with an alloy in small close grains of a light violet colour. Equal parts of tin and bismuth form a brittle alloy, of a medium colour between the two metals, and the fracture of which presents cubical facets.

Zinc unites perfectly with tin, and produces a hard metal, of a close-grained fracture; its ductility increases with the proportion of tin.

Antimony and tin form a white and brilliant alloy, which is distinguished from other alloys of tin by its possessing a less specific gravity than either of the two metals by which it is formed.

In combining arsenic with tin, precautions must be taken to prevent the arsenic from escaping by volatilization. Three parts of tin may be put into a retort, with one-eighth part of arsenic in powder; fit on a receiver, and make the retort red hot; very little arsenic rises, and a metallic lump is found at the bottom, containing about one-fifteenth part of arsenic; it crystallizes in large facets, is very brittle, and hard to melt.

If tin be kept in fusion with access of air, its surface is speedily covered with a greyish pellicle, which is renewed as fast as it is removed. If this grey oxide be pulverized and sifted, to separate the uncalcined tin, and calcined again for several hours, under a muffle, it becomes the yellow oxide of tin, called among artificers *putty of tin*, and extensively used in polishing of glass, steel, and other hard bodies.

A white oxide of tin is used in forming the opaque kind of glass called enamel. This composition is made by calcining 100 parts of lead and 30 parts of tin, in a furnace, and then fluxing these oxides with 100 parts of sand, and 20 of potash. This enamel is white, and is coloured with metallic oxides.

All the mineral acids dissolve tin, and it may be precipitated from its solutions by potash; but an excess of potash will re-dissolve the metal. Nitromuriate of gold is a test of tin in solution, with which it forms a fine purple precipitate.

The sulphuric acid dissolves tin, whether concentrated or diluted with water; part of the acid is decomposed, and flies off in the form of sulphurous acid gas. Heat accelerates the effect of the acid. Tin, dissolved in the sulphuric acid, is very caustic.

The solution of tin in the nitric acid is performed with astonishing rapidity, and the metal is precipitated almost instantly in the form of a white oxide. If this acid be loaded with all the tin it is capable of calcining, and the oxide be washed with a considerable quantity of distilled water, a salt may be obtained by evaporation, which detonates alone in a crucible well heated, and burns with a white and thick flame, like that of phosphorus. The nitric acid holds but a very small quantity of tin in solution, and when evaporated for the purpose of obtaining crystals, the dissolved portion quickly precipitates, and the acid remains nearly in a state of purity. Nitric acid, much diluted, holds rather more tin in solution, but lets it fall by standing, or by the application of heat.

The muriatic acid dissolves tin, whether cold or hot, diluted or concentrated. If fuming, and assisted by a gentle heat, the addition of the tin instantly causes it to lose its colour and property of emitting fumes, and a slight effervescence takes place. The acid dissolves more than half its weight of tin; the solution is yellowish, of a fetid smell, and affords no precipitate of oxide, like the sulphuric and nitric acids.

The oxy-muriatic acid dissolves tin very readily, and without effervescence, because the metal quickly absorbs the superabundant oxygen from the acid, and requires no decomposition of the water to effect its oxidation.

Nitro-muriatic acid, made with two parts of nitric acid, and one of muriatic acid, dissolves tin with effervescence. It is the solution of tin in this acid which the dyers employ to heighten the colour of their scarlet dyes. It is prepared by adding small portions at a time, of tin, to the common aquafortis of commerce: when the appearance of oxide is observed at the bottom of the jar, muriate of soda is added, by which its solution is effected. If the colour imparted by this solution is not bright, a little nitrate of potass is added to it.

The acetous, and most other vegetable acids, have some action upon tin, particularly when aided by a gentle heat; but the solutions thus obtained are not used in the arts. Tin decomposes the corrosive muriate of mercury. It is for this purpose amalgamated with a small portion of mercury and this amalgam, being first triturated in a mortar with the corrosive muriate, the mixture is then distilled by a gentle heat. A colourless liquor first passes over, and is followed by a thick white vapour, which issues with a kind of explosion, and covers the internal surface of the receiver with a very thin white crust. The vapour becomes condensed into a transparent liquor, which continually emits a thick, white, and very abundant fume. It was formerly called the *fuming liquor of Libavius*, and is the combination of the muriatic acid and tin.

Tin has a strong affinity for sulphur; the sulphuret of tin may be formed by fusing the two substances together: it is brittle, heavier than tin, and not fusible. It has a blueish colour, a lamellated texture, and is capable of crystallizing.

The white oxide of tin combines with sulphur, and forms a compound called *aurum musivum*, or *mosaic gold*, which is much used for giving to plaster-of-Paris the resemblance of bronze, and improving the appearance of bronze itself. It is also occasionally used to increase the effects of electrical machines. See **AURUM MUSIVUM**.

Tin possesses the property in a remarkable degree of promoting the fusibility of other metals, with which it is mixed. Two parts of lead, and one of tin, which forms the best plumber's solder, melt at a temperature of little more than 300° Fahr.; although the melting point of tin alone is 440°, and that of lead 612°. One part of tin, and two of lead, which forms the inferior plumber's solder, melt at a lower temperature than the first-mentioned proportions, notwithstanding the increased quantity of the less fusible metal. Eight parts of bismuth, (which melts *per se* at 480°,) five of lead, and three of tin, fuse at a heat below that of boiling water. It is this alloy of which tea-spoons are sometimes made, to surprise those who are ignorant of their nature, by their melting in a cup of hot tea.

The uses of tin are so very numerous, and so well known, as not to need detailing. We shall advert to only a few; viz. the fabrication of boilers and kettles for dyers' use; the worms of stills; the drawing of pipes, (erroneously called *pewter*) for gas conduits, for beer, wine, vinegar, and other acetous liquids, which have no action upon pure tin: if the tin were alloyed, it could not be drawn into sound pipes. Tin forms the principal ingredient in pewter of all qualities, and enters largely into the greater part of the white alloys in such extensive use. Immense quantities of tin are used in the fabrication of *tinned* iron plates, improperly called tin-plates. We may also here notice a new and most important application of this pure metal, (under a patent granted to Mr. John Warner, jun. founder, &c., of Cripplegate, London,) which is that of giving a perfect and beautiful coat of tin to lead pipes, which thus possess the valuable qualities of both metals; viz. the cheapness and flexibility of lead, and the purity and indestructibility of tin.

**TINNING.** The art of covering any metal with a thin coating of tin. Copper and iron are the metals most commonly tinned. The use of tinning these metals is to prevent them from being corroded by rust, as tin is not so easily acted upon by the air or water, as iron and copper are. What are commonly called tin-plates, or sheets, so much used for utensils of various kinds, are, in fact, iron plates coated with tin. The principal circumstance in the art of tinning is, to have the surfaces of the metal to be tinned perfectly clean and free from rust, and also that the melted tin may be perfectly metallic, and not covered with any ashes or calx of tin. When iron plates are to be tinned, they are first scoured, and then put into what is called a pickle, which is sulphuric acid diluted with water; this dissolves the rust or oxide that was left after scouring, and renders the surface perfectly clean. They are then again washed and scoured. They are now dipped in a vessel full of melted tin, the surface of which is covered with fat or oil, to defend it from the action of the air. By this means, the iron coming into contact with the melted tin in a perfectly metallic state, it comes out completely coated. When a small quantity of iron only is to be tinned, it is heated, and the tin rubbed on with a piece of cloth, or some tow, having first sprinkled the iron with some powdered resin, the use of which is to reduce the tin that may be oxidated. Any inflammable substance, as oil for instance, will have in some degree the same effect, which is owing to their attraction for oxygen. Sheets of copper may be tinned in the same manner as iron. Copper boilers, saucepans, and other kitchen utensils, are tinned after they are made. They are first scoured, then made hot, and the tin rubbed on as before with resin. Nothing ought to be used for this purpose but pure grain tin; but lead is frequently mixed with the tin, both to adulterate its quality, and make it lie on more easily; but it is a very pernicious practice, and ought to be severely reprobated.

**TITANIUM.** A new metal discovered by the Rev. Mr. Gregor, in the beginning of the present century, in Cornwall. Klaproth subsequently found it in the red-shorl of Hungary, and gave it the name of titanium. Lampadius was the first who completely reduced it, which he effected by charcoal only. The metal was of a dark copper colour, with much brilliancy, brittle, and in small scales considerably elastic. It tarnishes in the air, and is easily oxidised by heat: it then acquires a purple tint. It detonates with nitre, and is infusible. All the mineral acids act upon it with great energy. According to Vanquelin, it is volatilized by intense heat.

**TOBACCO.** The dried leaves of a foreign poisonous plant, most extensively cultivated in many parts of the world, to furnish a species of aliment to the depraved tastes of a large portion of the human race.

Tobacco is a potent narcotic, and also a strong stimulus, and in small doses proves violently emetic and purgative. The oil is remarkable for its extreme malignancy, and when applied to a wound, is said, by Redi, to be as fatal as the poison of a viper. The decoction, smoke, and powder are used in agriculture to destroy insects.

Tobacco being cultivated for the leaves, it is an object to render these as large and also as numerous as possible, and therefore the most fertile soil is preferred. It is very sensible to frost. The plants are raised on beds, early in spring, and when they have acquired four leaves, they are planted in the fields, in well prepared earth, about three feet distant every way. Every morning and evening the plants require to be looked over, in order to destroy a worm which sometimes invades the bud. When four or five inches high, they are moulded up. As soon as they have eight or nine leaves, and are ready to put forth a stalk, the top is nipped off, in order to make the leaves larger and thicker. After this the buds, which sprout from the axils of the leaves, are all plucked; and not a day is suffered to pass without examining the leaves, to destroy a large caterpillar, which is sometimes very destructive to them. When they are fit for cutting, which is known by the brittleness of the leaves, they are cut with a knife, close to the ground; and, after laying some time, are carried to the drying shed, where the plants are hung up by pairs, upon lines, having a space between, that they may not touch one another. In this state they remain to

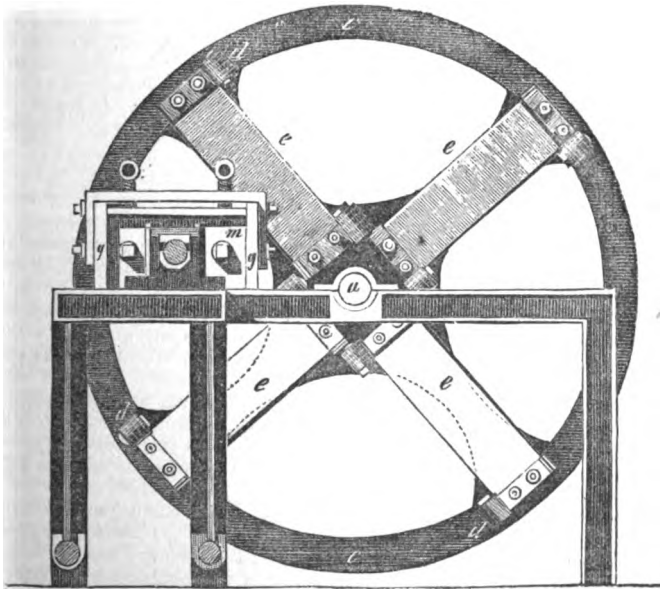
sweat and dry; when perfectly dry, the leaves are stripped from the stalks, and made into small bundles, tied with one of the leaves. These bundles are laid in heaps, and covered with blankets. Care is taken not to overheat them, for which reason the heaps are laid open to the air from time to time, and spread abroad. This operation is repeated till no more heat is perceived in the heaps, and the tobacco is then stowed in casks for exportation.

In the manufacture of tobacco, the leaves are first cleansed of any earth, dirt, or decayed parts; next, they are slightly moistened with salt and water, or water in which salt and other ingredients have been dissolved according to the taste of the fabricator. This liquor is called *tobacco sauce*.

The next operation is to remove the mid-rib of the leaves, which is reserved to be dried and ground for snuff. The leaves are then manufactured into a variety of articles, by rolling, twisting, and cutting; but the chief are the making of segars, and the cutting the leaves by a machine into fine shreds, for smoking with pipes, or chewing. The machine by which the latter operation is conducted is a very effective instrument, a knife being made to alternate vertically between grooves, with very great rapidity, while the tobacco leaves, confined in a channel, are gradually moved forward by a regulated quantity of motion under the operation of the knife, by which the shreds are uniformly cut of any required thickness.

A patent for an improvement in the machines used for this purpose, was taken out by Mr. Samuel Wellman Wright, in 1828. Instead of the alternating action of a single knife, Mr. Wright has introduced a series of knives, placed as radii to a wheel, which, as they revolve, cut the tobacco into shreds; much resembling in its action the chaff-cutting machine in general use, except that the knives in the latter have a curvature given to them, in order that they may

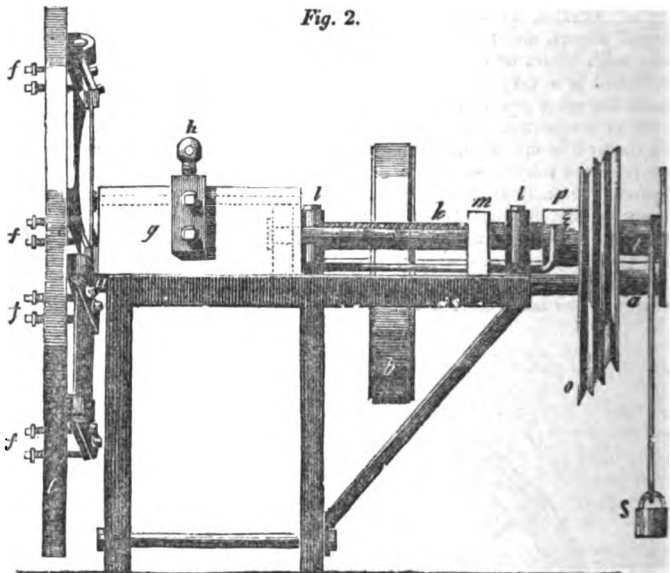
Fig. 1.



cut with a slicing action, and not with a chop, as in the machine we are about to describe, which may, however, be easily altered according to our suggestion.

Fig. 1, (above) and Fig. 2 annexed, represent two elevations or views of the

machine, one being at right angles to the other.  $a$  is the main axis, set in motion by the drum  $b$ ;  $c c$  is a fly-wheel having hinges  $d d$ , to which the cutters  $e e$  are attached by screws, (these are best seen in *Fig. 1*;) other screws  $f f$  are employed to adjust and set the hinges  $d d$ , so that the cutters shall press close to the front of the box  $g$ , in which the tobacco is placed;  $h h$  are two screws for pressing the tobacco down; and  $k$  a screw, by the turning of which it is pushed forward towards the cutters. This screw is supported in plunger blocks  $l l$ , and works in a nut fixed in a massive block  $m$ , from which two strong bars proceed to another block in the box  $g$ , which presses the tobacco forward by the revolution of the screw. On the axis of the screw is a treble pulley, driven by a cat-gut band from another pulley  $o$ , on the axis of  $a$ , which admit



of the velocity of the screw being varied according as the tobacco is required to be cut fine or coarse. The treble pulley is made to carry round a screw by a sliding clutch  $p$  in the axis of the screw, which is kept pressed by a fork lying in grooves in the clutch.

When the box requires a fresh supply of tobacco, the fork is turned back from the clutch, and a weight  $s$ , which has been wound upon the axis of a winch  $t$  descends, and turning the screw in the reverse direction, brings back the block to the other end of the box  $g$ .

**TODDY.** A juice drawn from various kinds of palms, by cutting off such branches as nature intended to bear fruit, and receiving from the wound the sap designed for the nourishment of the future crop. This juice being fermented and distilled with some other ingredients, forms the celebrated spirituous liquor called *arrack* or *rack*.

**TOMBAC.** An alloy of copper, with about one-sixth part of zinc.

**TOPAZ.** A precious stone found in Saxony, Bohemia, Siberia, and Brazil, mixed with other minerals, in granitic rocks. The yellow topaz of Brazil becomes red when exposed to a strong heat in a crucible; that of Saxony becomes white by the same process, showing that the colouring matter of each is not the same.

**TOPOGRAPHY.** A description or draft of some tract of land, as that of a city, town, villa, field, &c. as set out by surveyors.

**TORMENTOR.** An instrument much used in tillage, sometimes for breaking down the stiff clods, and at other times for skimming the surface turf, for the purpose of burning. It resembles a harrow in its general appearance, but runs upon wheels, and each tire is furnished with a hoe or share that enters and cuts up the ground.

**TORPEDO.** A sub-marine apparatus, invented by Robert Fulton for the purpose of destroying ships. It consisted of a vessel or case, charged with combustible matter, which he proposed to transfix by a harpoon to the bottom of a ship, by diving underneath it in his "nautilus," in which he sometimes remained under water for an hour at a time. Buonaparte employed him to apply his "infernal machine" to some British ships in the Channel; but Fulton failed in his attempts to fix his torpedoes; whereupon the impatient consul of the French republic regarded him as a quack, and dismissed him, unjustly observing, "Cet Americain était un charlatan, un escroc qui voulait seulement attraper de l'argent."

**TORTOISESHELL.** The shell of the tortoise, a testaceous animal, used in the fabrication of many articles of ornament and utility. The comb-makers and horn-turners of France, Holland, and Germany, make use of the parings and clippings of horn and tortoiseshell, in the manufacture of snuff-boxes, and a variety of elegant articles and toys. They first soften the material in boiling water, so as to be able to press it into iron moulds, and then, by means of heat, unite them intimately into one mass. Care must be taken that the heat be not so powerful as to scorch the material; and grease must be carefully avoided, as that prevents their union.

**TOURNIQUET.** A surgical instrument employed to stop bleeding.

**TOW.** Coarse undressed hemp, or old rope reduced to the filamentous state.

**TRAGACANTH.** A gum, also called gum adracant, and gum dragon, is the produce of the above, and some other shrubs. The gum is brought to us in long and slender pieces, of a flattened figure more or less; and these not straight, or rarely so, but commonly twisted or contorted various ways, so as to resemble worms. We sometimes meet with it, like the other vegetable exudations, in roundish drops, but these are much more rare. It is moderately heavy, of a firm consistence, and, properly speaking, very tough rather than hard, and is extremely difficult to powder, unless first carefully dried, and the mortar and pestle kept dry. Its natural colour is a pale white, and in the cleanest pieces it is something transparent. It is often, however, met with of a brownish tinge, and of other colours still more opaque. It has no smell, and very little taste, but what it has is disagreeable. Taken into the mouth, it does not grow clammy, and stick to the teeth, as gum arabic does, but melts into a kind of very soft mucilage. It dissolves in water but slowly, and communicates its mucilaginous quality to a great quantity of that fluid. It is by no means soluble in oily or spirituous liquors, nor is it inflammable. It is brought to us from the island of Crete, and from several parts of Asia. It is to be chosen in long twisted pieces of a whitish colour, free from all other colours, which must be rejected.

**TRAMMEL.** An instrument employed by artificers and draftsmen for drawing ellipses. It consists of a cross with two grooves at right angles to each other, and a beam containing two pins that are made to traverse in the grooves by the revolution of the bar; the bar carries a pencil that describes an ellipse.

**TRANSFERRING** of engravings and lithographic drawings from the paper, on to wood, or other material, is thus performed. The print is first placed in a vessel of water, until it is completely saturated, which will be in about five or ten minutes, and then placed between blotting paper to remove the superabundant water from its surface. It is then varnished by a brush, and applied immediately to the wood, which has been previously varnished and allowed to dry. The print, thus applied, may be subjected to the pressure necessary to effect its complete adhesion, by spreading over it a sheet of paper, and rubbing this with the hand. The paper on which the print was made may then be peeled off by rubbing it cautiously with the moistened fingers, and when wholly removed, a coat of varnish must be applied to the print. When coloured prints are to be transferred, an acid solution must be used instead of water, to



destroy the size which exists in the paper. This solution may be composed of two-thirds of vinegar and one-third of water, and is to be applied only to the back of the print. If the article is to be polished, apply several coats of varnish, allowing each to dry before the application of another; and then rub the surface with a piece of woollen cloth and pumice stone reduced to impalpable powder. When the surface becomes smooth, the process may be continued with a fine cloth, and the finest tripoli with olive oil.

**TRANSPARENCIES.** Is a term ordinarily applied to pictures, prepared with semi-transparent or translucent materials, and illuminated at the back, so as to exhibit them at night. The art of preparing them is as follows:—

The paper (or other material) must be fixed in a straining frame, in order to place it between the eye and the light, when required. After tracing the design, the colour must be laid on, in the usual method of stained drawings. When the tints are got in, place the picture against the window on a pane of glass framed for the purpose, and begin to strengthen the shadows with Indian ink, or with colours, according as the effect requires; laying the colours sometimes on both sides of the paper, to give greater force and depth of colour. The last touches for giving final strength to shadows and forms, are to be done with ivory-black or lamp-black prepared with gum-water, as there is no pigment so opaque and capable of giving strength and decision. When the drawing is finished, and every part has got its depth of colour and brilliancy, being perfectly dry, touch very carefully with spirits of turpentine, on both sides, those parts which are to be the brightest, such as the moon and fire; and those parts requiring less brightness, only on one side. Then lay on immediately, with a pencil, a varnish, made by dissolving one ounce of Canada balsam in an equal quantity of spirit of turpentine. Be cautious with the varnish, as it is apt to spread. When the varnish is dry, tinge the flame with red lead and gamboge, slightly touching the smoke next the flame. The moon must not be tinted with colour. Much depends upon the choice of the subject. The great point to be attained is a happy coincidence between the subject and the effect produced. The fine light should not be too near the moon, as its glare would tend to injure her pale silver light; those parts which are not interesting should be kept in an undistinguishable gloom; and where the principal light is, they should be marked with precision. Groups of figures should be well contrasted; those in shadow crossing those that are in light, by which means the opposition of light against shade is effected.

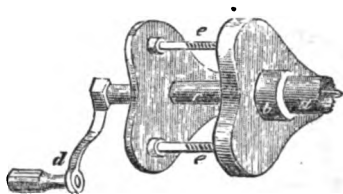
**TREAD-MILL.** Is a mill worked by the weight of persons treading upon the first movement, which is usually a wide cylindrical wheel, having upon its periphery a series of projecting steps or boards, resembling those of a water-wheel. The weight of the individuals continually climbing these steps, causes it to turn round, and put in motion any other machinery, by means of ordinary gear. Tread-mills are now resorted to pretty generally in this country, as a means of prison discipline; and the result has been, that men cannot be found to work this species of machine out of prison, conceiving the employment to be degrading. The Chinese raise water by a similar contrivance for irrigation.

**TREE-NAILS.** Are cylindrical wooden pins or bolts, used to fasten planks to timbers, especially in ship-building.

**TREPANNING.** Is a surgical operation for opening the skull in cases of fracture; a description of which does not form a part of the plan of this work, and we only introduce the subject, in order to describe the instrument by which it is performed, as the principle of its construction may be advantageously applied to other purposes. *a* represents a thin steel tube, the edge of which is serrated into fine sharp teeth, forming thereby an annular saw; it is fixed in a stout brass collar *b*, which is adjusted to the end of the axis *c*, and revolves therewith, when turned by the winch *d*. There are three screw supports, *e e*, to the upper and lower plates, which form the frame, and the distance of the plates from each other is adjustable by the screws *e e*. The end of the axis *c* is formed into a pointed drill, and extends a little beyond it.

The case which contains this instrument is provided with several sized annular saws, drills, and screws. The surgeons in using this instrument, (after removing

a portion of the scalp,) cut out a circular piece of bone, the central pin or drill preventing it from slipping, and the perforation thus made by the drill serves



afterwards for the insertion of a screw, by which the removal of the circular piece of bone is ensured. Access is thus gained under the arch of the skull for removing the splinters or raising the depressed parts, occasioned by the fracture. Circular saws of this description have already been applied for cutting out pillars and concentric cylinders from solid blocks of stone; and our mechanical readers will find out many other valuable uses for the application of a similar instrument.

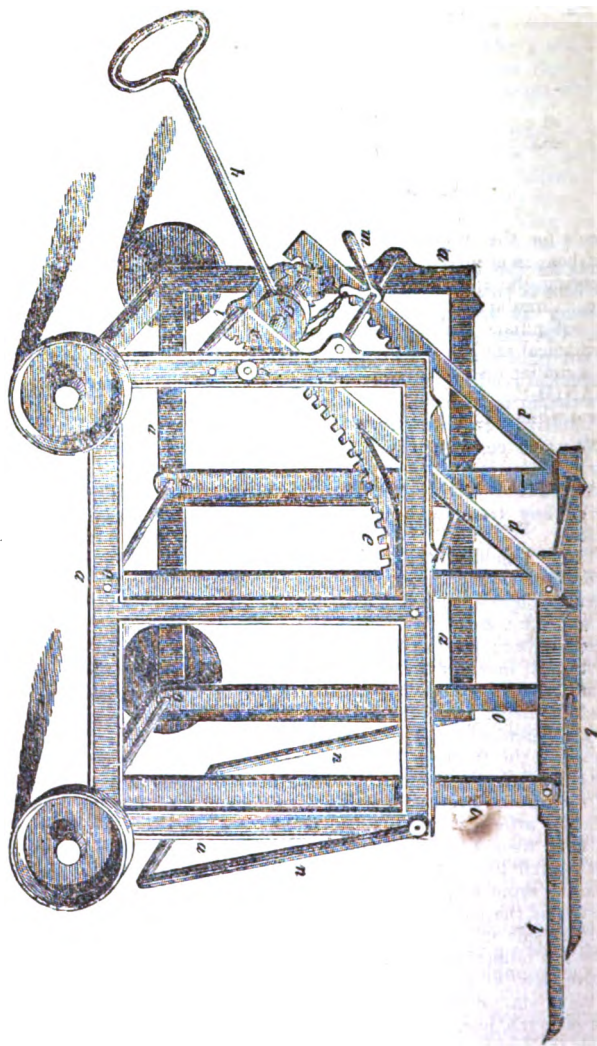
**TRIANGLE.** In geometry, a figure bounded or contained by three lines or sides, and which consequently has three angles, from whence the figure takes its name.

**TRIANGULAR-COMPASSES.** Are compasses with three legs, whereby to take off any triangle at once; much used in the construction of maps, globes, &c.

**TRUCK.** A small wheel carriage to be moved by hand; a species of barrow with two wheels; they are made in a great variety of forms, to adapt them to their peculiar objects, such as the moving of sacks, bags, casks, cases, lead, iron, copper, stone, &c. &c. To describe those simple, well-known machines, would be of little utility; we therefore confine our attention to a very ingeniously contrived truck, invented by Mr. S. W. Wright, and which is employed at the West India Dock Company's warehouses, for moving and stacking the sugar hogsheads in tiers; an operation previously performed by other mechanical means, and technically called "riding the hogsheads."

*a a* shows the frame of the truck, mounted upon four wheels, on which it runs; *b b* is the skid upon which the hogshead is raised into the position represented; *c c d d* are levers supporting the skid, and turning upon fulcrums at *o o*, to which are attached two toothed sectors *e e*, that are acted upon by two pinions fixed near to the ends of the axis *f*: this axis carries a click-box *g*, which is worked by a lever *h* attached to it: *i* is a ratchet-wheel on *f*, *l* a pall, acting on the same to prevent it receding; *m* a bent lever, for lifting by intermediate chains, the palls, and click, which allows the skid to descend to the level of the upper side of the frame *a a*; *n* is a handle for men to draw the truck. There are two ratchet wheels, and two palls, though only one can be seen in the perspective view given.

A crane is employed to lift the hogsheads upon the truck; the latter is then wheeled off to the pile, where the hogshead is raised by alternately raising and depressing the lever *h*, which turning round the axis *f*, causes the pinions fixed upon it to raise the toothed sectors and levers that support the skid; a reaction being prevented by the palls falling into the teeth of the ratchet-wheels as they turn round. We object generally to an intermitting motion, where a continuous one can be applied; and we can see no difficulty in applying it in the present instance by the introduction of winches in the usual way. Notwithstanding the slight imperfections that may at present attach to this machine, it must be pronounced an original and effective contrivance; and so sensible (it was reported) were the directors of the establishment before mentioned of the advantages attending the use of the new truck in their warehouses, as to present the inventor with the sum of a thousand pounds, over and above the amount of their contract for a great many of the machines.



**TRUMPET.** The loudest of all portable wind instruments; of which there are various kinds. In their most simple form, they consist of a metallic tube, with a large bell-shaped aperture at one end for the emission of the sound, and a mouth-piece at the other, adapted for blowing into it by the lips. See the words **EAR-TRUMPET** and **SPEAKING-TRUMPET**.

**TRUNDLE.** A small wheel with staff teeth; also called a lantern or wallower. This term is likewise given to the little carriages more generally called **TRUCKS**, which see.

**TRUNNIONS.** The short arms which project from the opposite sides of a piece of artillery, on which it is supported in its carriage, and becomes the

centre of motion upon altering its inclination. Trunnions are also employed in a similar manner to vibrating steam-engines, and in a great variety of other mechanism.

**TRUSS.** A term applied to many different things. In surgery, it is the bandage worn round the bodies of persons afflicted with hernia, or rupture. In sea affairs, it is a certain combination of pulleys, "to bowse the truss-pendants taught." In agricultural affairs, it is a certain bundle of hay, or straw, &c. The truss of hay weighs 56 lbs., and 36 trusses make a load. In commerce, there are trusses of other articles, in which the quantities vary.

**TUBE.** A hollow cylindrical body, made of metal, wood, or any other substance; the term is synonymous with **PIPE**; which see.

**TUN.** A large cask or barrel, which has probably derived its name from its capability to hold about a ton weight of ordinary liquids; or the measure of weight might be derived from that of capacity. A tun of vegetable oil is 236 gallons; of animal oil, 252 gallons; of wine, 252 gallons.

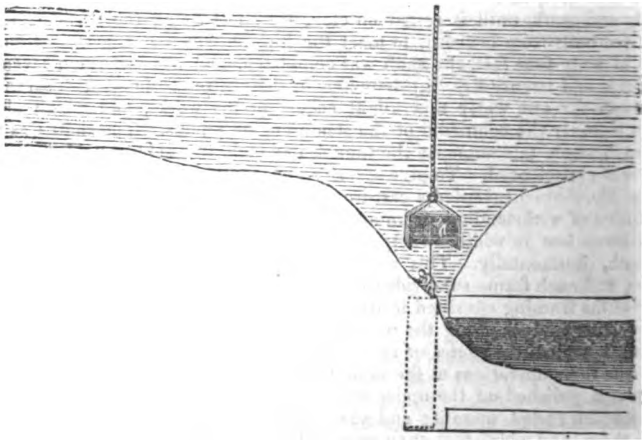
**TUNGSTEN.** A mineral found in Sweden, of an opaque white colour, and great weight; whence its name,—tungsten, or ponderous stone. This ore was analyzed by Schule, who found that it was composed of lime, and a peculiar earthy-like substance, which, from its properties, he called tungstic acid. The basis of the acid was found to contain a metal, which was named tungsten, and was obtained from the acid by charcoal.

**TUNNEL.** An artificial arch or passage under ground. They are employed as the means of conducting canals under elevated ground; for the formation of roads under rivers and canals, and in the construction of sewers and drains, &c., &c. Tunnels are now almost as common as canals and bridges. Amongst the many important works of this kind, may be mentioned, the canal tunnel under Standidge, between Manchester and Huddersfield, which extends under ground upwards of three miles, and is 220 yards below the surface. The railway tunnel under Liverpool. The road tunnel under the Thames, at Rotherhithe, which, although completed only half-way, is an undertaking of great national interest, and will, whenever finished, prove of great public utility. It is thirty-eight feet in width, and in the style of a double arcade, as shown in a sectional representation, which we shall have shortly to introduce. The work was commenced in 1825, by the building on the surface of the ground a circular brick tower, fifty feet in diameter, and three feet thick; this tower was gradually undermined all round, and sunk, until it rested on clay, forty feet below the surface; a wall was then built from beneath, to meet the kirk on which it stood, till from the depth of sixty-four feet, the shaft was completed, and a well formed seventeen feet deep, and twenty-five feet diameter, in the centre of the area, to serve as a receptacle for any water that might collect in the works, and which always brings it under the command of the steam-engine pumps. The shaft was then broken through, to commence the tunnel, in which, it is said, considerable difficulty was experienced. To give security and confidence to the men in excavating, Mr. Brunel invented a cast-iron shield or frame, of great solidity, so as to be capable of withstanding an immense pressure. Its extreme dimensions were thirty-seven feet in width, twenty-one feet six inches in height, and seven feet in depth, horizontally. This shield was divided into twelve perpendicular frames, and each frame subdivided into three stories, called cells or boxes. The utility of the framing consisted in its supporting the superincumbent weight, and in protecting and shielding the workmen employed from accident. One miner worked in each of the stories or cells, consequently, thirty-six men were enabled to pursue their operations at the same time. Each division had a roof of cast-iron plates, polished on the upper surface, so as to slip easily over the stratum of clay which rested upon it; and was supported by two strong cast-iron plates, called shoes, and which rest upon gravel at the base. The motion of each division was thus effected:—Each of the miners in the three cells excavated the ground in front of him, to the depth of nine inches, until the perpendicular height of the soil in front of the division, which was to be advanced, was excavated. He then supported the face of the soil by means of small planks called polings, and shut them with screws to the adjoining divisions, which were at

rest. The next operation consisted in unscrewing and slackening one of the legs, while the other supported the weight of the machine. The slackened leg was then advanced at two separate times to the length of nine inches, and then screwed up tight. When properly secured, the other leg was advanced, together with the shoes, in the same manner; and the division was then moved forward nine inches, by means of two horizontal screws and levers, one at the top and the other at the lower part of the division. One end of these screws was fixed in the frame, and the other abutted on the brickwork. Each of the divisions was moved in a similar manner, until the whole twelve were advanced nine inches, when the bricklayers immediately followed up with the brickwork and cement, building one brick in length in straight joints. This brickwork again formed an abutment for the horizontal screws; thus the work proceeded, alternately moving the machinery forward nine inches, and following it up with a course of brickwork in cement.

Notwithstanding these ingenious contrivances for ensuring the progress of the work (which reflect great credit upon the talents of the engineer), an irruption of water took place on the 18th of May, 1827; and as some account of the circumstances attending it may prove of importance to persons engaged in, or about to undertake, similar works, we shall here give it from the pages of a periodical journal published at the time.

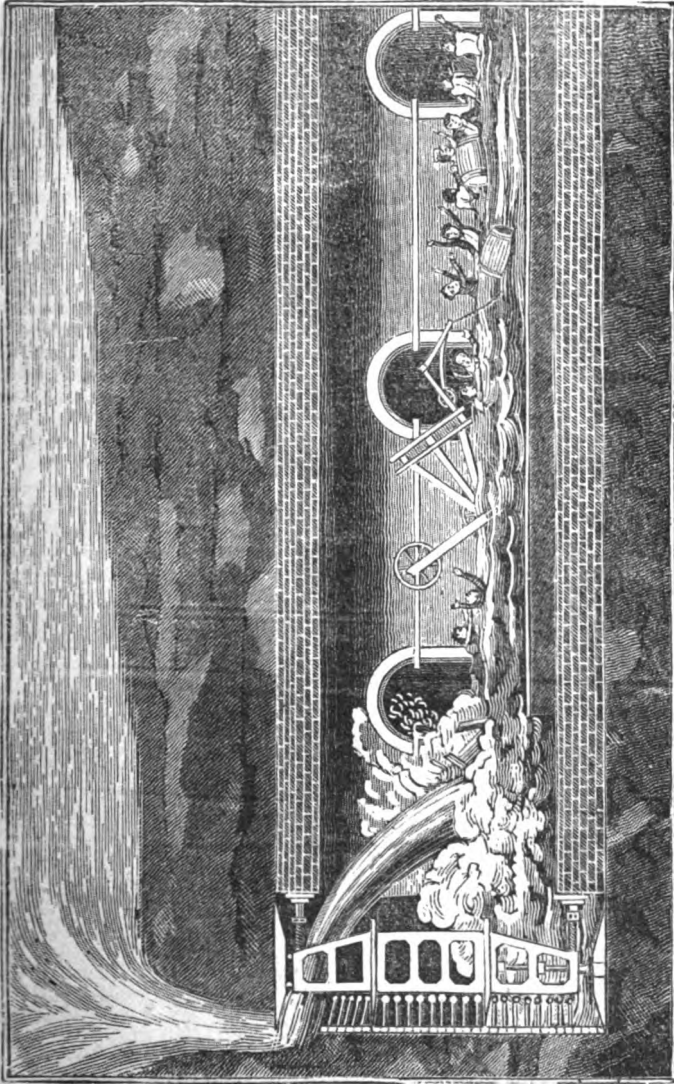
For several weeks previous to the irruption of the water, it was discovered, by the frequent descent of pieces of bone, brickbats, coals, &c., from the bed of the river to the works, that the earth, or rather the mud between the water and the tunnel, was exceedingly loose, and even at times in motion. Although much water had occasionally penetrated the works, the engine was found sufficient to remove it, and the work proceeded with very little interruption, till that time when the irruption of water between the shield and the brickwork was so great, as to oblige the men to make a hasty retreat, which they all did in safety. This irruption, which soon filled the tunnel, was much augmented by the action of the water on the last row of brickwork, before it was completed, and the cement had had time to set. On examining the bed of the river, after the accident, with the diving-bell, a spacious cavity was discovered over the spot, which terminated in a small hole, descending into the tunnel between the shield and the brickwork, as represented in the annexed sectional sketch. This hole, as



well as a second, which subsequently broke out in another part of the cavity, was afterwards filled up with bags of clay, and large quantities of loose clay or gravel, thus making an artificial bed to the river; and this new-made part was protected from the effects of the tide, by a raft thirty-five feet square, skirted with a tar-maulin, covering, in all, about 8,800 square feet. After a while, it

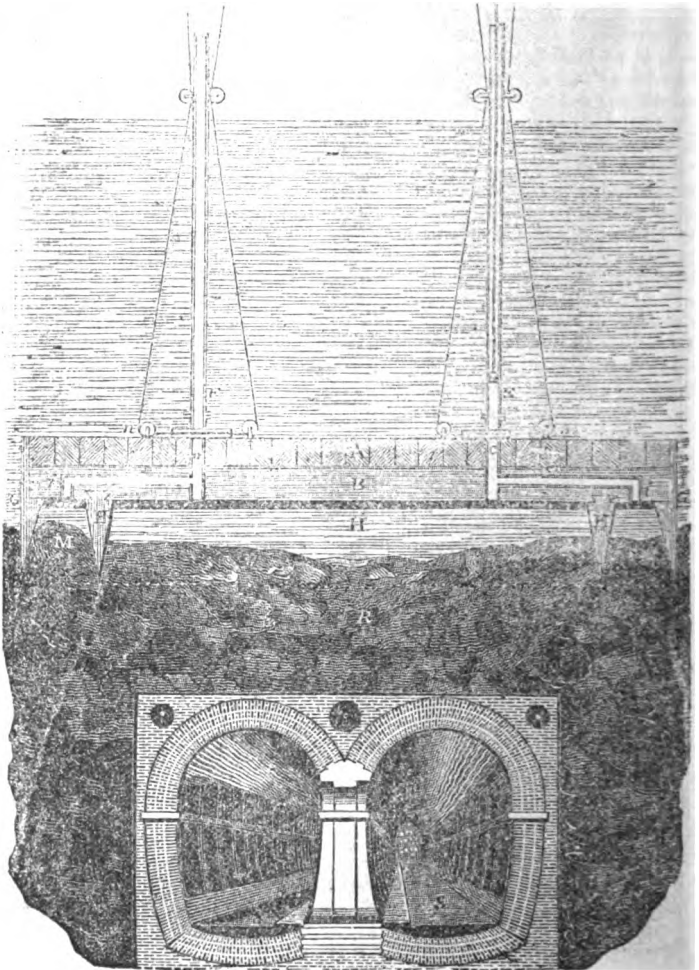
artificial covering having sufficiently settled, the water was drawn off by the engine, and the workings recommenced: after clearing away all obstructions before the shield, that piece of mechanism was found to be quite uninjured.

This magnificent undertaking was, however, doomed to a second misfortune, of a more disastrous character, which took place in January 1828, and was attended



with the lamentable loss of six lives. "The tide had just began to flow," says Mr Brunel, jun., "and finding the ground tolerably quiet, we proceeded by beginning at the top, and had worked about a foot downwards, when, on exposing the next six inches, the ground swelled suddenly, and a large quantity burst through

the opening thus made. This was followed instantly by a large body of water. The rush was so violent as to force the man on the spot where the burst took place, out of the frame or cell, on to the timber stage behind the frames." A general retreat instantly took place; but the agitation of the air, by the rush of water, having extinguished all the lights, confusion ensued; the timber stage was thrown over by the torrent, knocking down under it several men, and the tunnel rapidly filled. Those who could get to the eastern arch effected their escape, while others were carried by the force of the current to the end of the shaft. Of eighteen men, besides Mr. Brunel, jun., who were thus placed at the mercy of the torrent in utter darkness, six were drowned, and the remainder, more or less injured, were taken out of the water for the most part in a state of extreme exhaustion. The foregoing wood cut, which affords a correct representation of the lamentable occurrence, is inserted principally on account of its



embracing an accurate longitudinal section of the tunnel, and of the mechanism of the movable shield on the left hand, through the upper part of which the

water found entrance; the arched passages delineated in the back-ground, represent three of the entrances into the eastern arch, which is a parallel tunnel; these arched passages are continued at uniform distances throughout the whole length of the work. One of the tunnels was intended for the traffic from the north to the south shore of the Thames, and the other for the traffic from the south to the north, to prevent interruptions; a flagged foot-path, as well as a paved carriage road, being made in both the east and west tunnels, as shown in the cross section of the work in the lower part of the preceding cut, which we shall presently explain.

Such was the deep interest taken by ingenious and scientific men for the prosecution of this tunnel, that soon after the *first* irruption, Mr. Brunel received, (according to report,) no less than 260 written plans, which, together with verbal communications, made altogether 400 proposed remedies for the disaster. Amongst these there were some which displayed considerable ingenuity; and the best, according to our information, was the following, which we insert, as the application of the principle of its construction may hereafter prove of eminent utility in tunnelling under a body of water. The inventor was a Mr. Garvey, a modeller, and an active member of the London Mechanics' Institution, and who, we regret to add, fell an early victim to the cholera in 1832. Mr. Garvey's plan, as stated by himself, "consists in placing at the bottom of the river, directly over the part undergoing excavation, a large platform or raft, with ledges proceeding downwards to fix into the soil, to prevent the water from entering the excavation."

The nature and operation of this will be understood by reference to the drawing on page 808, where S S represents a section of the tunnel; K the mud, gravel, &c., constituting the bed of the river; A B, the square platform, about twice the width of the tunnel, consisting of two layers of planks, crossing each other at right angles, and made water and air-tight by a stratum of artificial leather, tarpauling, or other elastic waterproof material, between the layers; G G, and H H, represent sections of the ledges or rims, which may be made of iron, or wood pointed with iron; the platform must be loaded sufficiently to sink in water. F is a pipe for the escape of the air while the platform is descending in the water; and E is a pump to draw off the water from under it, when it reaches the bottom; *vv* are sliding valves, to be opened or shut at pleasure, by the cords passing over the pulleys *mm* and *nn*; the bent pipes *ii* are for the escape of the air or water, from the space between the ledges G and H. When the apparatus is put down to the bottom of the river, the water is to be removed from underneath by the pump E, which will produce a very great hydrostatic and pneumatic pressure on its surface, and cause the points of the ledges, G and H, to penetrate the bed of the river, and the whole to become firmly fixed in its place. The cavity M, which extends of course all round the raft, is made conical, for the purpose of compressing the soil between the rims as they are forced down, and thus preventing the entrance of the water at the edges.

When the apparatus is to be moved forward to a new station, the pump E is to be converted into a condensing air-pump, by changing the valves; and air is to be forced under the raft till it is disengaged from the bottom, *when it can with facility be moved forward in the water, and sunk as before.*

When the bed of the river is very irregular and gravelly, it may be necessary to dredge it, and put down clay in some parts before the platform is brought to its place.

Having described that which is stated to have been the best of the rejected plans, (as acknowledged by Mr. Brunel to the inventor of it, the late Mr. Garvey,) we shall proceed to notice that which was unfortunately adopted in preference. The concavity in the bed of the river, and the hole through which the water rushed into the tunnel on the 18th of May, was first filled with clay, bags of clay and gravel; a large flat wooden raft, (*without ledges,*) was then sunk over the new-made ground, to prevent any sudden displacement of it, and by that means afford a full protection to the workmen, when they might recommence excavating *underneath*. The water, however, found its way under the raft, and the powerful engine and pumps were employed for a considerable



period without lowering the level of it in the tunnel. The works were about half emptied of the water, when the force of the tide raised up one side of the raft, threw off the weights which had kept it down, when it floated up to the surface of the river. The ground in another part contiguous to the former hole now gave way, and the tunnel was again filled with water. Fresh quantities of clay and bags of clay were then employed to fill up the second hole; and the enlarged dimensions of the former, occasioned by a settling or movement of the artificial ground, was also filled up to a level with the natural bed of the river. The clay was covered with a stratum of gravel, and this by a large and very thick tarpauling, which was kept down by cast-iron kintledge; another layer was thrown over the whole, to keep it as closely together as possible. Although this plan has proved an effectual remedy as far as it has been applied, the repetition of such remedies, whenever quicksand may be met with, or irruptions formed in the future progress of the work, must be attended with a wasteful expense: we therefore submit that Mr. Garvey's plan deserves the preference, as it may be shifted from place to place, as the work proceeds.

The lamentable accident which we described was also productive of an excellent plan from an eminent member of the London Mechanics' Institution, which consists in introducing, a few yards behind the workmen, flood-gates, so constructed, that the lower parts of the gates will be first shut by the water issuing in at the place where the work is carried on; and when the waters rise nearly half way up, then to shut the middle parts of the gates; and when it rises near to the top, to shut the top parts of the gates. This arrangement would afford all the workmen time, who could reach so far as the flood-gates, to get safe out, and prevent the tunnel from being filled with water. This plan would not only tend to obviate much of the danger to be apprehended by the workmen, but greatly diminish the enormous expense consequent from such an accident. The small space between the shield and the flood-gates would soon become filled with mud and sand, and the bed of the river might then be soon made good from above, as then there would be no liability of the materials put down for that purpose being loosened, and removed, by the periodical ingress and egress of the water during the rise and fall of the tide. The cut on the next page exhibits a transverse section of the tunnel, with the gates, &c.

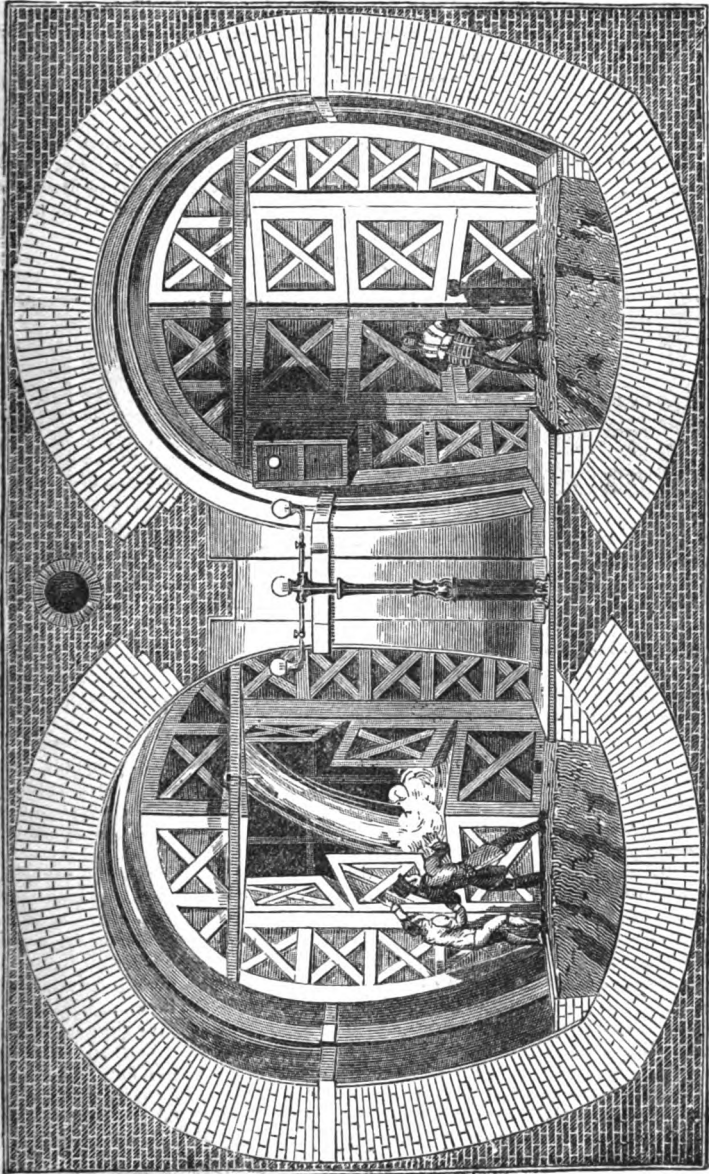
Fig. 1 represents a front view of the gates, with those on the right hand or eastern arch entirely closed, those in the other arch having been kept open for taking through the clay and building materials, as the excavation proceeds. In order to make the plan better understood, the water is represented as coming in, which, having just closed the lower pair of gates, is in the act of shutting the middle pair, while the upper pair is represented as standing open.

The lower pair of gates are beveled off to an acute angle, which terminates at the outside of the upper edge; and to correspond with this, the lower edges of the middle gates are beveled off in a contrary way, to lap over the others, as exhibited in the drawing. From this arrangement, it will be perceived that the middle gates will be partly in the water before it runs over the lower gates; and hence, the second gates will be shut as soon as the water begins to run over the first. The same arrangement is made with respect to the middle and upper gates, except that the upper edges of the latter are beveled to an angle on the inside, to fit a contrary bevel on the top of the gateway. It may be here observed that none of the flood-gates are made to open so far back as to become parallel with the side of the tunnel, consequently they are always in a situation to be acted upon by the water; and, that the whole of the gates, as well as the framework in each arch, meet in the middle of the arch, as flood-gates on canals do, at such an angle as to afford the greatest resistance to the pressure of the fluid. To prevent the outward lateral pressure of the sides of the framing against the brickwork, and the injury it might thereby sustain, the opposite sides of the framing in each arch are connected by tie-beams, similar to those used in roofing.

It will not be necessary to make the whole area of the arch to open, as a comparatively small opening will be sufficient for conducting the operation of

the miners. The opening gates are therefore represented as occupying only a small portion in the middle of the strong framing which fills up the arch.

Fig. 1.

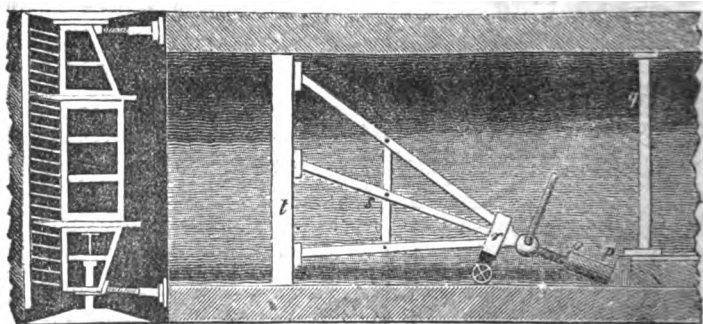


It will of course be of the greatest importance that the threshold, or cells, against which the bottoms of the first gates shut, and for that purpose the portion of the road-way which passes through the gates, is so balanced and supported, that a very small portion of water accumulated under it will disengage its supports, and project part of the road-way or platform outside of the gates. The threshold may be further secured, if necessary, by a covering of canvas, so attached to the gates as to be rolled off by them in the act of shutting.

The joinings between the frame and brick-work, as well as the joinings round the gates, are made air and water-tight, by triangular packings of leather or other soft material, which are drawn into the crevices by a series of screw-bolts through to the outside of the gates, where the workmen can, at their leisure, screw the packing up after all the gates are shut.

The method of moving the gates forward, and of securing them in their places, is shown in *Fig. 2*, where *l* represents a vertical section of a set of flood-gates, supported in its place by three pair of strong beams, represented at *4*, fastened together at *r*; the other ends of these beams are attached to the flood-

*Fig. 2.*



gates, three on each side, at a small distance from the edge. The piece *r* rests upon a friction-roller or small wheel, and against a powerful screw-jack *s*, which is supported by the abutment *p*, fixed into the bottom of the tunnel, and kept in its place by the vertical beam *q*.

When the gates are to be moved forward, the triangular packing round the edges of the frame must be released, and moved back, by unscrewing the bolts, which keep it in its place, and then the gates are forced forward on the smooth supports, on which they rest, by the screw *o*; and when they have been moved to their assigned place, the screw is returned into its box, and the abutments are brought up, and the whole apparatus again properly secured.

The box represented to the left of the eastern arch is sufficiently capacious to hold two or three men; it is provided with two doors, one of which opens into the box, and the other into that part of the tunnel which would be full of water when the flood-gates are all closed. The use of this box is for a man, harnessed in James's diving apparatus, to enter the part filled with water, for the purpose of exploring and examining the works, and bringing out any thing of importance, requiring to be removed from the water. The man, having provided in his diving apparatus a sufficient supply of air for the time he intends to remain in the water, enters the box, and closes the door; he then, by means of a stop-cock, admits the water into the box, when the door between the box and the interior can be easily opened to admit him. In coming out, he has only to re-enter the box, shut the communication between the box and the interior, and then, by a stop-cock, let the water contained in the box issue into the open part of the tunnel.

This may be repeated as often as occasion may require, with very little

escape of water, and with perfect safety to the diver; for the ingress of the water being entirely prevented by the flood-gates, it will be perfectly quiescent within them, and no danger is to be apprehended from a change or derangement of any part of the works taking place during the miner's inspection. The small space between the shield and flood-gates would soon be filled, when all would become stationary; and consequently the principal cause of damage to the works, the rushing of a large quantity of water with great violence, would be removed. If it should be objected, that the time occupied in filling the space between the gates and the shield would be too short to allow the workmen to escape; it may be answered, that very little time would be required for all the workmen to get outside, where they would be perfectly safe, and might leisurely view the progress of the water in filling the space, and closing the gates: besides, an irruption of the water, under such circumstances, would be of so little consequence, that there would be no occasion for detaining the men in attempting to stop the torrent, till their lives are in danger. The water within being perfectly still, the bed of the river might be made good, the water pumped out, and the work might be going on again, in the course of a day or two after an irruption, if checked by such means as are herein described.

At the period we are writing, (February 1833,) the work at the Thames tunnel is at a stand. A brick wall has been completed at the further extremity of the excavation, which is made water-tight, and the interior of the tunnel is as perfect as though no accidents had happened.

**TURF.** A mixture of earth with the roots and leaves of plants, partially decomposed; it is used as fuel in many parts of the country. See PEAT.

**TURMERIC, or INDIAN SAFFRON.** A root brought from the East Indies, and employed in making a yellow dye. The colouring matter it yields is very abundant, and of great brilliancy of tint; but it possesses no durability, nor have any mordants yet been discovered sufficiently powerful to fix it. Common salt and ammonia have been recommended for this purpose; but they are found to deepen the colour, and incline it to brown.

**TURNING.** The art of giving circular and other forms to solid substances, is the fabrication of innumerable articles, by the aid of a machine called a lathe. There is perhaps no contrivance with which human ingenuity has aided the dexterity of the mechanic more entitled to our admiration than the lathe; especially when we take into the account all the improvements it has undergone, from its simplest and most ancient form in the potter's wheel, to that adaptation of varied and complex mechanism, by which not merely circular turning of the most beautiful and accurate description, but exquisite figure-work, and complicated geometrical designs, depending upon the eccentric and cycloidal movements, are daily produced.

The operation of turning differs very essentially from most others, in the circumstance, that the matter operated upon is put in motion by the machine, and is wrought by means of edge tools, presented to it, and held fast; whilst in most others the work is fixed, and the tool put in motion. In ordinary turning, the work is made to revolve on a stationary straight line as an axis, while an edge tool, set steady to the outside of the substance in a circumvolution thereof, cuts off all the parts which lie farthest from the axis, and makes the outside of that substance concentric with the axis. In this case, any section of the work made at right angles to the work will be of a circular figure; but there are methods of turning ellipses and various other curves, distinguished by the name of engine-turning.

Lathes are made in a great variety of forms, and put in motion by different means: they are called *centre lathes* where the work is supported at both ends; *mandrel, spindle, or chuck lathes* when the work is fixed at the projecting extremity of a spindle. From different methods of putting them in motion, they are called *pole-lathes*, and *hand-wheel lathes*, or *foot-lathes*; for great works they are turned by horses, and water-wheels, but more generally by steam-engines. The lathes used by wood-turners are usually made of wood, in a simple form, and are called *bed-lathes*; the same kind will serve for turning iron and brass: but the best work in metal is always done in iron-lathes, which

are usually made with a triangular bar, and are called *bar-lathes*. Small ones, for the use of watch-makers, are denominated *turn-benches*; but there is no essential distinction between these and the centre lathes, except in regard to size, and that they are made in metal instead of wood, and the workmanship being more accurate and better finished.

The centre lathe is now very little used but by country turners, to make articles of household furniture in soft wood, as table-legs, staircase-rails, bed-posts, &c. It consists of the following parts: 1st. The *bed*, which is composed of two beams bolted together at a small distance asunder, and parallel to each other; it is supported horizontally on legs at the ends, and forms the support of the whole; the *groove* is the narrow opening between the two halves or clucks of the bed, to receive the tenons of the *puppets*, which are two short upright posts fastened down upon the bed at any place by means of wedges, driven through mortices in the tenons of the puppets beneath the bed; one of the puppets has a *pike* or pin of iron fixed into it, and the other one has at the same level the *centre-screw*, working through a nut fastened in the puppet; both the screw and the pike have sharp points made of steel, and hardened and tempered that they may not wear away; they must be exactly opposite, and in a line with each other. The piece of wood which is to be turned, suppose, for instance, a pole of wood, is supported by its ends between the points of the pike and the screw, that it may turn round freely, and the screw is screwed up, till it has no shake. The puppets can be placed at any distance asunder, according to the length.

The rest is a rail or bar, extending from one puppet to the other, for the support of the tool; it lays in hooks projecting from the faces of the puppets; the work is put in motion by means of the *treadle*, which is worked by the turner's foot; the string or cat-gut is fastened to the treadle, and passing two or three times round the work, it is fastened to the end of an elastic pole, fixed to the ceiling over the turner's head: now as the turner presses the treadle down by his foot, the string turns the work round, and a sharp chisel or gouge, being held against the wood upon the rest, will cut the wood to a circular form. When he has brought the treadle to the ground, he releases the weight of his foot, and the elasticity of the pole draws up the treadles, turning the work back again; during which retrograde motion he withdraws the chisel from the work, as it would not cut in this direction through it, and might impede the motion of the wood; and the pole is fastened to the ceiling of the room, where the lathe is placed by a pin, upon which it can be turned about as a centre, and it rests upon a horizontal bar fixed at some distance from the centre: it is placed in a position nearly perpendicular to the axis of the work, so that, when it is turned upon its centre pin, the string at the other end may be brought over any part of the length of the work where it will be most convenient for the turner to have the string put round it: in the same manner the end of the treadle is placed, with one end over a centre pin in the floor, that its opposite end may be moved under the work to the proper place for the string. It is held in this position, while moving up and down, by a second treadle, perpendicular to the first, which moves in a loose centre on the floor at one end, and the other is perforated with a number of holes to receive a pin fixed in the first treadle, and thus to confine the treadle to move up and down under any place it is set to: the end of the principal treadle is turned in the lathe, and made like a pulley, to hold the line or string which is wound upon it, and the turner winds the string on or off this end of the treadle, to adjust its length to the diameter of the work round which the string passes; the string is fastened to the end of the spring-pole in a similar manner. The workman stands, or is seated before his lathe, having one of his feet on the treadle, to give the motion; it must be very moderate and equal; he places his tool on the rest, and approaches the head of it gently to the piece, performing his work gradually without leaving any ridges, and when he meets with a knot, he must go on still more gently, otherwise he would be in danger both of splitting his work, and breaking the edge of his tool. For turning light work, a bow, such as is used for shooting arrows, is suspended by its middle over the lathe; the

string is then tied to the middle of the bow-string instead of the pole, and acts in the same manner. The continued rotary motion given by a wheel is so much superior for turning to the reciprocating motion of a treadle and string, that regular turners seldom make use of the latter; yet the simplicity and cheapness of the whole is a great recommendation, especially among country workmen, who are not so careful of their time as in the towns, where competition obliges every one to use the best and quickest means of despatching his work.

The common centre-lathe becomes a powerful machine when worked by means of a large wheel, turned by one or more labourers; the wheel should be heavy, that its momentum may be sufficient to overcome any trifling obstacle in the work, and the frame in which it is mounted must be of sufficient weight to stand steady, and not be liable to move by the exertions of the man turning it. An endless line is used to communicate the motion of the wheel to the work; it passes round a groove in the circumference of the wheel, and, after crossing like a figure of 8, goes round a small pulley fixed upon the work; by this means, when the great wheel is turned, it gives a rapid rotary motion to the matter to be turned, and with a much greater power than can be obtained from the treadle, with the additional advantage of the work turning always the same way round, so that the turner has no need to take his tool off the work; the small pulley is perforated with a square hole, to receive a square made on the end of the work, and the turner has many different pulleys, each with a different sized hole through it, to suit work of different diameters; but there is an inconvenience attending this method, for if the four corners of the square on which the pulley is fitted be not all equally distant from the centre of the work, the pulley will not turn round truly, and the band will be liable to slip round upon it. To obviate this, the pulley in the annexed figure is often



used; it has a square hole through it to receive the work, and is made to fit upon it by means of four screws *a a a a*, passing through a part of the wood by the side of the pulley, and their point pressing into the work; in this manner one or two pulleys can be made to serve work of any dimensions, and can always be set truly upon it; it has, as shown in the edge view, two different sized grooves, in either of which the band may be worked when required.

There is a kind of centre-lathe, which is generally employed by millwrights and iron-founders, in turning heavy metal work, such as the gudgeons of mill-shafts, rollers for sugar or rolling-mills, pump-rods, which are to pass through stuffing-boxes, or, in short, any work which will admit of having both its ends supported on centres; it is in many respects similar to that we have described, but is adapted to give a continued rotary motion to the work; it has legs which support it from the floor, and the bed is formed by two parallel beams or cheeks, bolted to the legs; one of the legs stand up above the bed to support the main, or left-hand centre point, instead of having a puppet on purpose. The centre pin is fastened into it, by a nut and screw behind, and upon this pin two wooden pulleys are fitted side by side, close to each other, so that they appear but one; either of these, at pleasure, is caused to turn round by means of an endless strap, going round a drum, extending over head or under the floor, and which is turned by horses, or a steam-engine; the strap being only the breadth of one of the pulleys, will turn but one of them at a time, but it can easily be shifted from one to the other at pleasure, and then the other will stand still. The front one of these pulleys gives motion to the work.

The back puppet is fixed upon the bed of the lathe, by a tenon projecting downwards, and entering the space between the two chucks of the bed; it is fixed at any place, by means of a screw-bolt, which passes down through the puppet, and goes through a piece of iron, which takes its bearing on the under side of the bed; a nut is fitted in this screw, and thereby the whole puppet can be drawn down upon the cheeks so firmly that it will not move by any strain the work may occasion: the back puppet has a back centre screw, which has a steel point to support the work.

The work is turned about in this lathe by means of an iron pin, projecting some inches from the flat surface of the front pulley, which, as before mentioned, is fitted on the centre point: a piece of iron, called a driver, is screwed upon the work near its left hand end, so as to project perpendicularly from it, and the pin in the pulley intercepts this as it turns, carrying the work round with it.

The other pulley, which is fitted on the centre pin, is only of use when the lathe is wanted to stand still, in the same manner as the live and dead pulleys used in cotton-mills. When the workman wishes to put the lathe in motion, he presses the handle of his tool, or any other smooth piece of wood, against the edge of the endless strap while it is in motion, and pushes it towards the front pulley; in a very short time the strap will get completely on the pulley, and shift itself to a fresh place on the drum corresponding to the pulley; this causes the pulley to turn round, and by the pin pushing round the end of the driver screwed on the work, communicates its motion to the work to be turned. When he wishes the motion to cease, for the purpose of examining his work, he pushes the strap back again on to the other pulley, which has no communication with the work, as it slips freely on the centre pin: the driver is simply an iron ring, having a screw tapped through one end of it, to pinch the work so fast as to prevent its slipping.

The side opposite the screw should be angular, that it may fit any sized work; this driver may be fixed on either end of the work, while the other is turning, but when it is necessary to fix the driver on that part of the work which is finished, the end of the screw is apt to pinch and bruise it; it is therefore proper to use a driver composed of two bars of iron screwed together by two screws, passing through one bar tapped into the other; both bars are somewhat hollowed out in the middle, that they may encompass the work. If this should be found to injure the work, a piece of sheet-lead wrapped round it before the driver is put on, will prevent the possibility of its damaging the work, and if the screws of the driver are drawn very tight, it will carry the work about with sufficient force to bear turning.

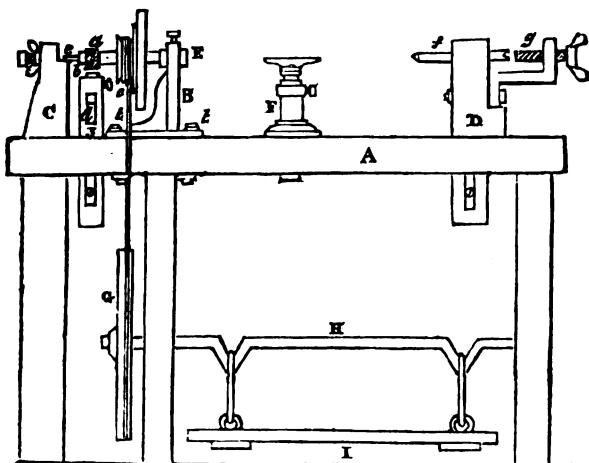
The manner of mounting and giving motion to a piece of work in the centre lathe is thus:—the back puppet is first fastened on the bed of the lathe, at the proper length to receive the work; the workman then places one of its ends against the points of the front centre, with the points as near the centre of the work as he can guess; he then brings the centre of the other end of the work opposite the point of the centre screw, and screws it up so as to hold the work just tight enough to prevent its falling down. In this state by turning it round by one hand, while he holds a piece of chalk against it with the other, he finds whether it is pitched nearly concentric on the points; and if it varies much any points, he turns back the screw and tries again, observing to shift the centre-point nearer towards that side which appears to project farthest in revolving, and therefore gets marked with the chalk. When he has found the true centre, he screws up the point so hard that it may mark the end of the work; then, taking the work out of the lathe, he punches or drills holes in the end, where the screw and centre points have marked, and when the work is returned into the lathe it will run nearly concentric; the driver being screwed fast on either end of the work as is most convenient, the work will be turned round by the pin projecting from the pulley as before described. The turning of heavy iron-work, for which these lathes are used, is performed by various tools chiefly called hooks, but these will be further described.

The centre lathe will perform any kind of work which can be turned upon centres made in the ends of it; but a great portion of the articles formed in the

lathe, must have one of their ends at liberty, to be operated upon while they are turning, as cups, boxes, and all kinds of hollow articles; these are turned in

*The foot lathe, with mandril and collar.*—A lathe of this kind serves equally well for centre work; therefore if the professed turner is without a mandril lathe, one of these constructed in the simplest and most economical manner, and chiefly of wood, that the artificer may be enabled to make it himself, is shown in the annexed figure.

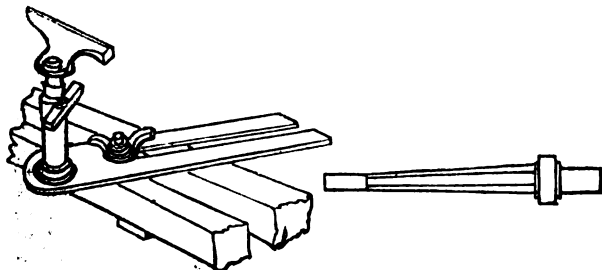
Fig. 1.



It is put in motion by a foot-wheel and treadle, so that the turner has both hands at liberty for directing the tools. A is the bed of the lathe, consisting of two beams or cheeks, fixed parallel to each other, and leaving a small space

Fig. 2.

Fig. 3.



between them, as shown in Fig. 2. The bed is supported by three upright legs, as shown in the figure; one of these projects above the bed a sufficient height to form one of the puppets C, for the support of the extremity of the spindle or mandril e E; the other end is supported in a collar fixed in an iron standard or puppet B, which is screwed down upon the bed, by two bolts marked *l l*. The back puppet D has a tenon which is received through the bed, by which it can



be fastened at any place ; *f* is the back centre pin, fitted through the puppet ; and *g* is a screw situated behind it, to advance and keep it up to his work. The mandril is turned round by a band of cat-gut passing round the pulley *c*, and also round the large foot-wheel *G*, which is made of cast iron, and fixed on the end of the axis *H* ; this is bent as in the figure, to form two cranks, united by two iron links to the treadle *I*, on which the workman presses his foot ; this treadle is affixed by two short boards to an axis on which the treadle *I* moves. The wheel *G* is of considerable weight in the rim, and being wedged fast on the axis, turns round with it ; it is the momentum of this wheel that continues to turn the work while the crank and treadle are rising, and consequently while the workman exerts no power upon them. When the crank has passed the vertical position, and begins to descend, he presses his foot upon the treadle, to give the wheel a sufficient impetus to continue its motion until it arrives at the same position again.

The length of the iron links, which connect the cranks with the treadle *I*, must be such that when the cranks are at the lowest, the board *I* of the treadle, to which the links are hooked, should hang about two or three inches from the floor. The turner gives the wheel a small turn with his hands, till the crank rise to the highest, and pass a little beyond it, then by a quick tread he brings the cranks down again, putting the wheel in motion with a velocity that will carry it several revolutions ; he must observe to begin his next tread just when the cranks pass the highest point, and then it will continue running the same way with a tolerably regular motion, if he is punctual in the time of his treads.

The rest which supports the tool while it is in the act of turning, is made of iron, as shown in *Fig. 2* ; it is supported on the bed of the lathe by its foot, which is divided by a groove in the manner of a fork, to receive a screw bolt, going down through the lathe-bed, and fastening it at any place along it by a thumb-nut ; the groove in the foot is for the purpose of allowing the rest to be moved to and from the centre of the lathe, to adjust it to the diameter of the work which is turning. The height of the rest is of some importance in turning ; and for some work it should be fixed higher than others ; therefore the shank of the cross piece, or *T*, upon which the tool is laid, is received into a socket in the foot of *F*, and can be held at any height by a screw. As the socket is cylindrical, the edge of the rest can be placed inclined to the axis of the work, when turning cones, or other similar work ; though the same purpose may be accomplished by the screw which holds the foot of the rest down to the bed of the lathe, admitting it to stand in an oblique direction.

The mandril or spindle is the most important part of the lathe ; it is made of iron, in the manner shown at *Fig. 3* ; but the two extremities are of steel, which are hardened after being turned and finished ; the small end has a hole made in it to receive the point of a screw, which, as shown at *e*, *Fig. 1*, supports the end of it ; the other end of the mandril is made larger, and has a hole within it cut with a female screw, for the purpose of fixing on the various chucks by which the work is turned ; the outside surface of the end is turned extremely true, and is fitted in a brass collar at the top of the standard *B* ; one of the bolts, marked *t*, which fasten the standard down, goes through a stout iron plate, situated beneath the bed, passing between the two wooden cheeks. In the top of the standard is a square hole, for the reception of two pieces or dies of brass which include the mandril between them ; these are kept in their places by a piece of iron *i*, fastened down by screws *l l* ; and *m* is a screw tapped through this, which presses the two dies together, and thus adjusts them to receive the neck of the mandril without any shake. The screw which supports the other extremity of the mandril fits in two iron or brass nuts, which are let into the back and front of the wooden puppet *C*, and by turning this, the mandril can be adjusted to run very correctly in length ; to prevent the screw from turning back when the lathe is in motion, a nut is placed on the screw outside of the puppet, and after the screw is turned by its head to fit and held up the mandril, the nut is screwed firmly against the nut which is let into the outside of the puppet ; this causes such a pressure upon the threads of the

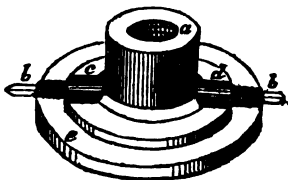
screw, that it is in no danger of turning back, as it would otherwise be liable to do with rough work.

The mandril by this means runs very steady and accurately in its bearings; and it is plain that any piece of work being firmly attached to the end of it, by means of the screw before-mentioned, may be turned by a tool held over the rest, in the same manner as if it was mounted between centres, but with the advantage that it be turned at the end, to make hollow work when required. The foot-wheel causes the mandril to revolve very rapidly, so that it will perform its work very quick, and the workman must acquire a habit of standing steady before his work, that he does not give his whole body a motion when his foot rises and falls with the treadle I.

The tools used in turning are numerous, and for the most very simple; they consist chiefly of chisels and gouges, and hooked tools, with edges differently beveled, so as to adapt them to their peculiar objects; tools with serrated edges for cutting solid and hollow screws; callipers of several kinds, gauges, oil-stone, &c. To describe all these things and their peculiar uses, would occupy too large a space; we therefore proceed to notice some of the more important apparatus and improvements which have been of late years made in lathes, and with which some of our readers are perhaps not yet acquainted.

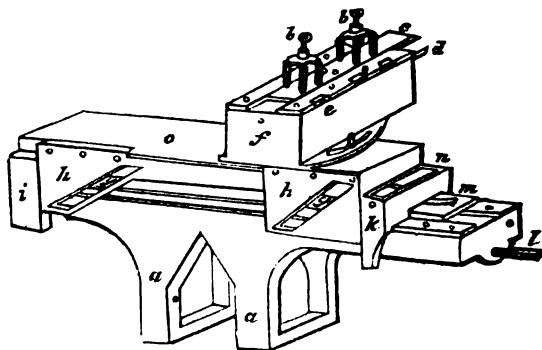
A very elegant and useful lathe, especially for amateur turning, was many years ago made by Mr. Henry Maudslay, of London. The most important feature in this improved turning machine, was the substitution of a triangular or prismatic bar, upon which the rest and centre puppet are constructed so as to slide, instead of aliding between parallel rectangular cheeks, as in the last we described. Since the first introduction of this lathe, (about 30 years since,) the triangular bar has been universally applied in lathes of the best kind. Some of the appendages introduced with Maudslay's lathe are particularly deserving of attention.

The first we shall describe is the universal chuck, of which the subjoined figure will convey an accurate conception. At *a* is a hollow screw, at the bottom of which is another screw, *b b*, which is prevented from moving endwise by a collar in the middle of it. One end of the screw is cut right-handed and the other left-handed; so that by turning it one way, the nuts *c d* will recede from each other, or by turning it the contrary way, they will advance towards each other. These two nuts pass through grooved openings in the plate *e*, and project beyond the same, carrying jaws like those of a vice, by means of which the substance to be turned is held.



Another very important and useful appendage to Mr. Maudslay's lathe, was his slide rest, which instrument is now universally employed in the best kind of lathes, for turning the faces of wheels, hollow work, and numerous other purposes. Since its introduction it has received many valuable modifications. It is represented in the subjoined engraving. At *a a* is a triangular opening to receive the triangular bar before mentioned, which is closed against the lower surface of the bar by means of clamps and screws, not represented. The tool for cutting is fixed in the two holders *b b*, by their screws; these holders are fastened by a sliding plate *c*, which can be moved backward and forward by the screw *d*, causing the tool to advance or recede. When it is necessary, as the turning of the insides of cones, &c., that the tool should not be parallel to the spindle of the lathe, the screw at *e*, and another similar one behind, must be loosed, so as to allow the circular plate under the box *f*, to turn upon its centre. Near the four upper corners of the lower portion of the rest are small projections, two of which *g g* are seen; they have inclined sides, and fit into corresponding angular openings *h h* of the upper part of the instrument, which slides or rises between the piece *i* and the base *k*, in such a way as to prevent any other than a vertical motion. When this slide tool is placed on the bar to be

used, the distance from the centre is adjusted by the screw *l*, which moves the slide *m* in its groove, and all the apparatus upon it; while by the screw *s* the slide may be moved in a direction perpendicular to the bar, and the projections acting in the slits *h h*, the plate *o* will be raised or lowered as required.



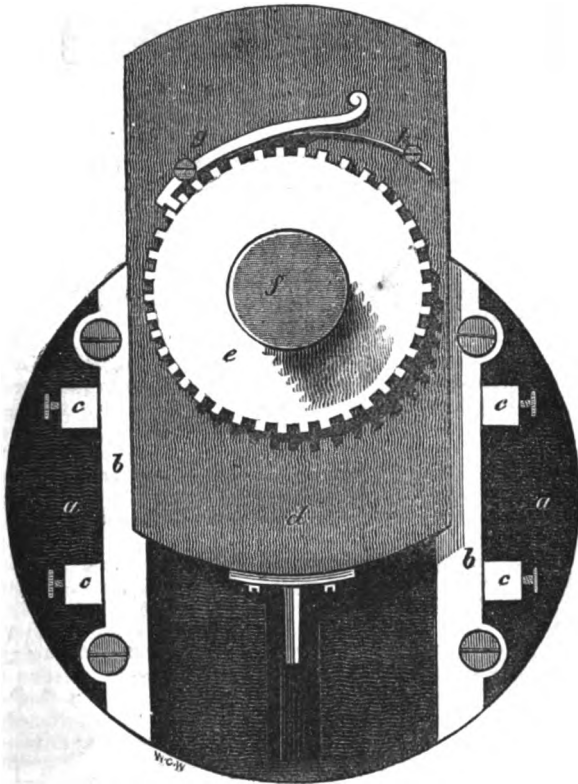
Such lathes as we have already described, are not well adapted to the turning of long rods and cylinders, such as are required in large steam-engines and various massive machinery, on account of the necessity of repeatedly shifting the rest, and the difficulty of keeping the work perfectly uniform in thickness through a considerable length. Engineers therefore facilitate the turning of such surfaces by means of another machine called a slide lathe, by which the work is performed with great ease and exactness. The principle of this invention consists in so constructing and attaching the body or carriage of the tool, that instead of being screwed down to one place during the operation of the tool, and requiring to be advanced at intervals as the work proceeds, it shall slide along the surface of the bench in a direction parallel to a line drawn through the centre of the spindle. At the same time the tool, instead of being merely held upon the rest with the fingers, is firmly fixed in its proper position by screws, so that it can neither be driven off without taking effect, nor yet be drawn by its keenness so as to spoil the work. The whole is managed in such a way that, as the iron to be turned revolves between the centre points, the rest, with its cutter or chisel advances slowly along in a certain direction, so as to produce a perfectly level rod. But besides the exactness attainable by this method, there is likewise the advantage of economy; as one man, who would with hard labour apply the tool to one point at once at a common lathe, may easily attend to, and keep in work, two or three slides.

The degree of velocity with which the surface of an article being turned, ought to pass the edge of the tool so as to be cut by it, differs materially in relation to different metals. Cast-iron, in consequence of its open grain, and containing as it generally does many impurities, is required to revolve very slowly, so as to pass the edge of the cutting tool only at the rate of about 100 feet per minute; wrought iron and steel are usually turned when revolving at a rate of about twice as quick; and brass cuts well when coming in contact with the chisel at the rate of about 300 feet per minute. To produce the requisite velocity according to the material or size of the work, pulleys of different diameters are fastened on the spindle, as already stated; so that the larger the work, the larger the pulley, and *vice versa*.

Mr. Ibbetson, an amateur turner of great celebrity, and the author of a pretty book on eccentric turning, has made many improvements in the mechanism for ornamental turning; his eccentric chuck is exhibited in the annexed figure.

*a a* is a plate of brass of sufficient solidity, on which are fixed two slides of steel *b b*, by means of screws; the holes which admit the screws are made a

little oval to enable the slides to move nearer to, or farther from, each other, if necessary; *c c c c* are four pieces of metal firmly fixed to plate *a*, and having a screw in each, which presses on the slides *b b*; *d* is a plate of metal or brass, sliding between *b b* in a dovetail, and must be made to fit very accurately when

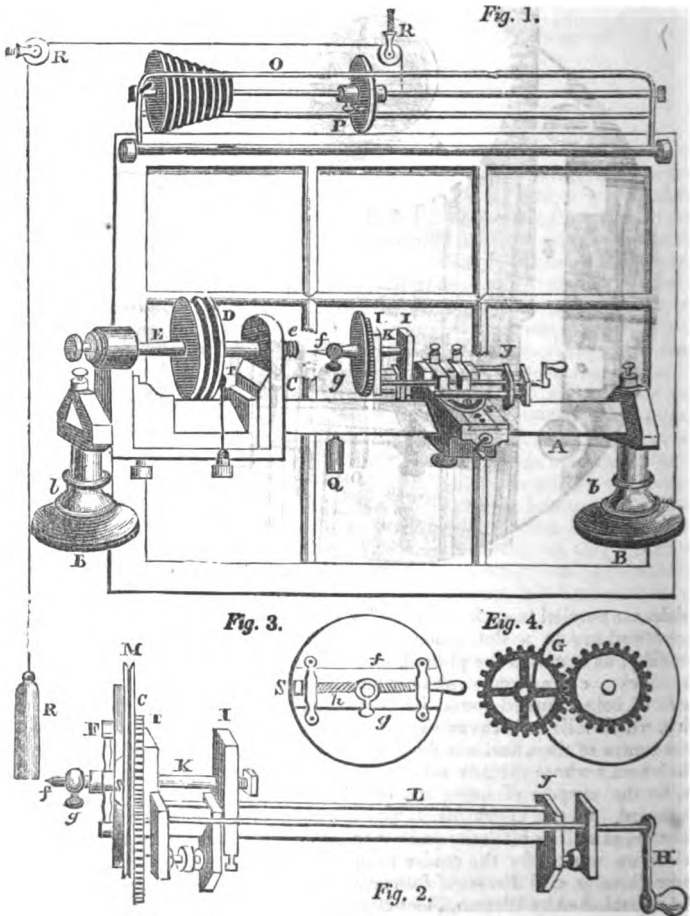


the slides are parallel to each other, and is moved between the slides by means of a screw working in a slot made in the plate *a*, and which regulates the eccentricity, as it moves the plate *d*, either nearer to, or farther from, the centre of the chuck. *e* is a circular plate, whose edge is cut into teeth, and which is capable of being turned round its centre, and is held in any position by the catch *g*, which falls in between the teeth, and is held in its place by a spring *h*. On the centre of the wheel *e* is fixed a screw *f*, (exhibited by the shadow thrown on the wheel,) whose threads correspond with the screw of the mandril on the lathe, for the purpose of fixing any chuck, on which is fastened the substance to be turned. To this chuck Mr. Ibbetson has adapted a slide-rest, of a peculiar description, as well as his lathe and other appendages thereto, for an explanation of which we must refer the reader to his work, entitled *Specimens in Eccentric Circular Turning, with Practical Instructions for producing corresponding Pieces in that Art*, published by Wetton, Fleet-street. This work is illustrated by upwards of sixty copper-plate engravings, and imitations of wood-cuts of a superior description; and it is due to the ingenious author not to omit noticing, that they were all produced in the lathe by himself. In the following page we give a

copy of two of the figures of the simplest combinations of circles, to which, as well as to all others, the author has annexed plain practical instructions, so that the



novice may proceed step by step to produce the same figures by turning the screws of the slide-rest and the eccentric chuck through prescribed spaces; and from these simple figures, by similar successive operations, he may proceed to the most elaborate and beautiful designs.



We shall now add a description of Mr. W. E. Wightman's (of Maldon, in Yorkshire) excellent lathe, as explained by himself in a periodical journal,

feeling assured that it may prove of the most eminent service to mechanics, as the arrangements are extremely simple and easily understood, and the construction such as any tolerable workman can accomplish, and avail himself of the advantages it offers, at a moderate cost.

"*Fig. 1* represents the lathe, with the cutter-frame fixed in the compound sliding rest, ready for use. *A*, the triangular bar on which the machine is mounted. *B B*, two pillars, which support the bar; the parts *b b* fix it to the lathe-frame. *C*, the left-hand head; *D*, the pulley; *E*, the mandril; *e*, the screw on which the chucks are fixed; *F*, the cutter-frame; *f*, the cutter; *G*, two wheels, which give a slow motion to the cutter-frame; *H*, the rod and handle of the slow motion; *I I*, two heads or puppets, in which is fixed the spindle *K*, of the cutter-frame; *L*, a bar of steel, on which the puppets are fixed, and which also fastens the cutter-frame to the compound sliding rest, by passing it through a hole in the tool-frame, as will be seen, on reference to the figure, the part *y* removing for the purpose; *M*, a groove turned on the edge of the cutter-frame, for the string *N* to work on; *O* represents the frame for double stringing the lathe; *P*, a movable pulley, whereby it may [be fixed perpendicularly over the cutter-frame; *Q*, a weight attached to a pulley behind the bar, for keeping the string *N* tight; *R R R*, the pulley's string and weight connected with the frame *O*, for double stringing the lathe; *T*, the index to the division-plate; *S*, one of two screws for changing the rectangular position of the compound sliding-rest to an oblique. *S*, *Figs. 2* and *3*, represents the slide of the cutter-frame; and *h*, *Fig. 3*, the screw, whereby the slide is moved; *g*, the screw for fastening the cutter. *Fig. 2*, is an enlarged view of the cutter-frame, when removed from the rest. *Fig. 3*, represents the face of the cutter-frame. *Fig. 4*, the back of it, with the wheels of the hand-motion. The letters refer to the same parts in all the figures.

"This machinery is intended to supersede the use of the eccentric chuck, by assuming a more natural and easy method of engraving, by the tool or cutter tracing the work, instead of the article doing it, that is to be ornamented. By this improvement, the action of the tool is more distinctly seen, than could be, by the movement of the chuck, especially after a few circles have been cut; for, by their rotation, the eye (particularly of an amateur) is soon fatigued, and yet to these inconveniences a turner must continue to submit, if no better method could be contrived.

"The principal advantages of the present invention, are the following. At a comparatively trifling expense, (to the costly machinery now in use,) a turner may be put in possession of an apparatus, which will answer all the purposes of eccentric and cycloidal turning, and which will, at the same time, form a complete drilling frame. As an apparatus intended to supersede the use of the eccentric chuck, it combines many advantages, amongst which, three may be mentioned that are of importance:—1st, As all patterns are worked by the divisions of the plate on the small wheel of the lathe, a much more extensive variety of circles can be obtained, than could be by the divisions of the eccentric chuck. 2d, By slackening the screws *ss*, in the large slide of the compound sliding-rest, a change may be effected from the rectangular position of the cutter-frame, to an oblique position; and, after the proper angle is obtained, (the screws being tightened,) the segments of circles can be worked round a centre with greater accuracy, than could be by tracing over patterns which I believe is the common method; while the alteration of my machinery, for such purpose, would scarcely occupy a minute of time; an object which is of no small importance for the dispatch of business. 3d, The loss of time in centring the work, occasioned by the necessity of removing it from one chuck to another, to receive the different ornaments, (an evil severely felt by turners,) is obviated by my improvement; as also the great difficulty, so often experienced in getting the face of the work to run true again, after taking it from one chuck to another; from their liability to get out of truth by the wearing of the screws in fixing them to, and removing them from, the spindle of the lathe; in which case every effort at fine-finishing would be inevitably defeated.

"To apply my apparatus for cycloidal turning, the addition of a rod is required to connect the cutter-frame with the universal chuck, after it is screwed on the spindle of the lathe; but which, on account of its connexion, (being a bad draughtsman,) I am unable to send. The following description will, I hope make its construction appear sufficiently intelligible.



"The edge of the plate of the universal chuck, (the machine on which the work to be turned and ornamented is fixed, and which is a common appendage to all lathes,) I have divided into 144 equal parts, which form a wheel: and upon the face of the left-hand head of the lathe is fixed a plate, and a corre-

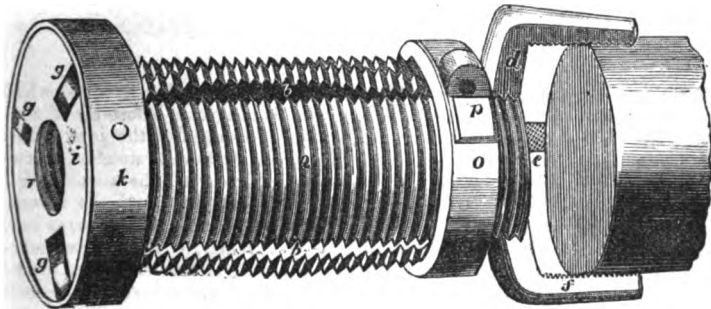
sponding one on the side of the rest, through which the axis of the rod connecting the chuck and cutter-frame revolves. Now if upon the rod is fixed a wheel of twelve teeth, working on the wheel formed by the edge of the universal chuck; and if upon the other end of the rod is fixed a wheel of the same size and number as those which work the cutter-frame, and to work in one of those wheels; then it must be obvious, that, by the chuck revolving once, the wheel of twelve would make twelve revolutions, which number would be given to the cutter-frame, thereby tracing an accurate circle of twelve cycloids. Again, by changing the wheel of twelve to another of proper proportions of 144, a number of cycloids would be described equal to that proportion. Then, by sliding the connecting-rod out of gear, and moving the universal chuck any number of teeth forward or backward, the cycloids would beautifully intersect each other.

"It may, perhaps, be unnecessary to add, that this, and the eccentric apparatus, must be worked by the hand-motion of the cutter-frame." (In the opposite page are given two specimens of wood-blocks, cut by Mr. Wightman in less than four hours.)

"To change it into a drilling frame, all that is required, consists in throwing all the wheels out of gear, and passing a string over the groove in the cutter-frame, to work on a pulley P, which is fixed on the same arbor as the pulley used in double-stringing a lathe. Then pass a string, (which should be kept for the purpose,) over the last-mentioned pulley, and under the large or fly-wheel of the lathe; and after the drill has been fixed in the socket of the cutter-frame, and adjusted to run true, or central, the machine will be ready for work. Now it must be clear that, by working the treadle of the lathe, as in turning, a rotary motion would be given to the cutter-frame; and after the tool has been advanced to the work, then, by moving the large or right angle slide of the rest, a straight line would be drilled, of a length in proportion to the movement of the slide. Then change the division of the plate on the small wheel of the lathe, and if the first line was cut *from* the centre, then cut the next *to* the centre, and so on till the whole is completed, when a beautiful circle of straight lines would be cut from a centre."

A very ingenious expanding chuck was invented by Mr. Lewis Gompertz. *Figs. 1 and 2* represent two perspective views of the chuck; the first, as employed to grasp a piece of wood of large dimensions; *Fig. 2.* is an opposite view

*Fig. 1.*

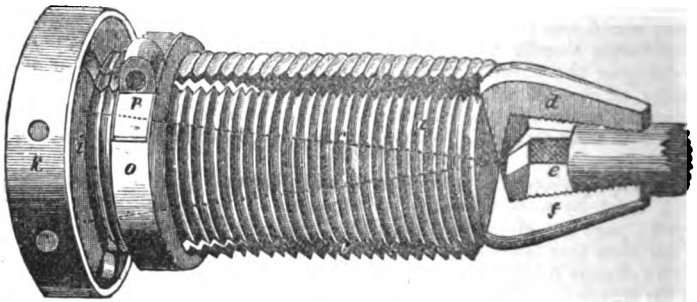


with the jaws collapsed, to bite a smaller object. *Fig. 3* shows one of the claws or jaws separately. The same letters refer to the same parts. The body of the chuck *a*, is cylindrical, and made of hard wood, with a screw-thread cut on its periphery. Three longitudinal rectangular grooves *b b*, (only two of which are seen,) are then made throughout its length, slantingly, as



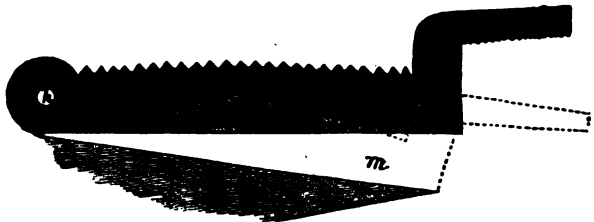
shown by the dotted lines *c c*, *Fig. 2*. The three clamps, *d e f*, one of which is shown entire by *Fig. 2*, are then fixed in these grooves by their jointed ends,

*Fig. 2.*



by means of a pin through their centres *k*, which pass through the solid back of the chuck *i*, and are rivetted to *k*, the metallic hoop of the same. The clamps thus fixed have a range of motion in the grooves, as represented more clearly by *Fig. 2*; the shaded part *l* shows the clamp in the position, when employed, as seen in *Fig. 1*; the same in dotted lines *m*, as when employed in *Fig. 3*;

*Fig. 3.*



and the angular piece *n* represents that portion of a triangular pyramid which is formed in the centre of the cylinder *a*, by the slanting cuts before-mentioned. The clamps *d e f* are made strong, steeled, and hardened at the jaws; their external edges (curved as represented) are filed into grooves or notches, to correspond with the screw-thread on the hard wood cylinder *a*; the metallic ring, or circular nut *o*, which is, of course, cut with a screw to fit both the former, can therefore be wound over any part of the cylinder, and by that means hold down the clamps firmly to the object they grasp. When the ring is situated as in *Fig. 1*, the jaws are open to receive a large piece; and when moved round towards the back, the ring operates to press down the clamps, owing to the curvature of their serrated backs. The projection *p*, on the ring *o*, is for the convenience of applying any thing to it, to move it round forcibly, and a hole is made through it, for the insertion of a wire. The jaws of the clamps should be notched like those of a vice, to obtain a secure hold of the objects placed between them; *r* is the screw, by which the chuck is fixed to the lathe.

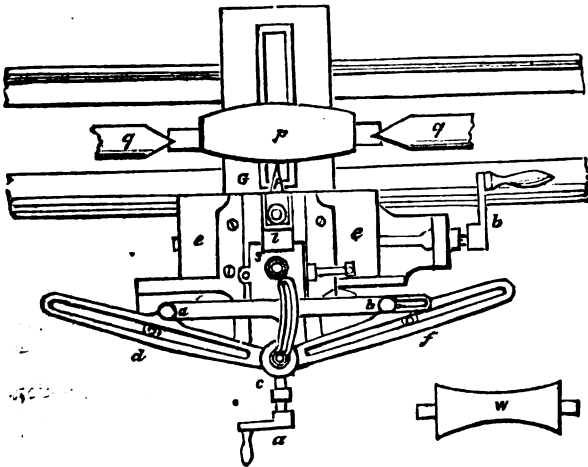
We shall close the present article by the description of a beautiful invention, by Mr. John Anderson, a member of the London Mechanics' Institution, to whom was awarded, in 1830, the annual prize, "for the best machine, or im-

provement of a machine;" and of whom Dr. Birkbeck (in a public address on the distribution of the prizes,) elegantly and justly observed, that he had "elevated himself in society, by becoming its benefactor;" that, "though now a working millwright, Mr. Anderson had evinced a genius that pointed him out for a distinguished engineer—probably a Smeaton or a Watt; neither of whom, at his age, possessed so much knowledge of algebra, or of geometry, and neither of them had *then* given such decided proofs of genius."

After the Doctor had explained the construction and use of the instrument, which was an improved slide-rest for lathes, Mr. Anderson gave a practical illustration of its utility by turning a convex and a concave roller, which were completed with great expedition, and fitted each other with mathematical exactness. In this improved slide-rest the object proposed, was to turn the surfaces of the bodies circular in the longitudinal direction: the curved surface in such direction being either convex or concave to the axis of rotation. And it was more especially intended to apply when the degree of curvature required was very small, or, which is the same thing, when the radius of the required curve was very great, as, by the present mode of turning, the greatest difficulty is found in such cases. The improved rest is also found to be equally applicable to the turning of bodies in the form of lenses, whether convex or concave; and in each of these cases the facility of operation, and accuracy of performance, is equal to that of the common slide-rest in turning straight or flat surfaces.

The principle of the improvement or circle-turning appendage depends upon two geometrical propositions: 1st, that all angles in the same segment of a circle are equal; and 2d, that a straight line of any length, being made to move always parallel to itself with one end touching a circle, the other end will describe a circle equal in every respect to the first.

Now in the improved slide-rest, shown in the annexed figure, the triangle *d c f*



is made to slide against the fixed pins at *d* and *f*; whence the vertex *c* will describe a portion of a circle greater or less in diameter, according as the angle *d c f* is made more or less obtuse; and further, the centre of the circle thus described, will be on the one side or the other of a straight line joining *d j*, according as the vertex *c* of the triangle is on the opposite side.

The sliding triangle *d c f* consists of three pieces; viz. of two sides *d c*, and *c f*, with a slit or opening in each for the pins *d* and *f* to slide in; and they are movable round a centre at *c*, by which means they can be made to

form any angle with each other. The third piece, or base of the triangle, is the connecting-bar  $ab$ , by means of which the two sides are held fast in any required position.

The sliding-plate  $ee$  is similar to that of a common slide-rest, and it is moved backward or forward by a screw and handle  $b$ , in the same manner. Upon this plate, and at right angles to the direction in which it moves, a box  $s$  is made to slide; within this box there is another sliding piece  $l$ , carrying the tool or cutter  $t$ . The interior sliding-piece  $l$  is made to move within the box by means of a screw turned by the handle  $a$ ; and by this means the cutter  $t$  can be made to advance or recede, as in a common slide-rest. The sliding-box  $s$  is connected with, and movable round the centre  $c$ , at the vertex of the sliding triangle; and hence if the box  $s$  move in any direction, the vertex  $c$  of the triangle must move along with it in the same direction.

Now suppose it were required to turn a body of the form  $P$  in the figure. Set the sides  $dc$  and  $cf$  to the proper angle; then screw the three nuts  $acb$  tight, which will retain them in that position. By means of the screw and handle  $a$ , make the sliding piece and cutter  $t$  advance as near the body  $p$  as is necessary to turn it of the required diameter. Then by the screw and handle  $b$  move along the sliding-plate  $ee$ , which plate will carry along with it the sliding piece, carrying the cutter  $t$ , the sliding-box  $s$ , and the sliding triangle  $dcf$ . But it will be readily perceived, that as the triangle  $dcf$  moves along, the vertex  $c$  will describe a portion of a circle; and as the end of the sliding-box  $s$  is connected with the centre  $c$ , the box will move along always parallel to itself, with that end touching the circle described by the vertex of the triangle. But the box  $s$ , and the sliding-piece carrying the cutter, may be considered as forming only one piece, as they always retain the same relative position to each other, except when altered by turning the screw and handle  $a$ . And hence the joint of the cutter  $t$ , and centre  $c$ , may be considered as the two ends of a straight line, which always moves parallel to itself; and as the one end  $c$  always touches the circle described by the vertex of the sliding triangle, the other end will (according to the geometrical proposition,) describe the portion of a circle equal to it in every respect; and will thus, by the revolution of the body  $p$ , turn it of the form required.

The separate *Fig. w*, represents a concave roller, produced by shifting the vertex of the triangle, or centre  $c$ , to the opposite side of the connecting bar  $ab$ .

**TURPENTINE.** A transparent resinous juice, flowing either naturally or artificially, by making incisions from a variety of unctuous trees, as the larch, pine, fir, &c. The essential oil distilled from this resin is called spirit, or oil of turpentine.

**TUTENAG.** A name given in India to the metallic zinc. The Chinese copper is also called by this name, which is alloyed with zinc, and forms a very hard and white metal, but little disposed to tarnish.

**TYMPAN.** The double folding-frame in which the sheet of paper is held to receive the impression in printing.

**TYMPANUM, or TYMPAN.** In Mechanics, a kind of wheel placed round an axis, or cylindrical beam, on the top of which are two levers for turning the axis, and therewith the weight required.

**TYPE.** The metallic letters, and other characters used in printing.

**TYPOGRAPHY.** The art of printing. See **PRINTING**.

## U.

**ULTRAMARINE.** A beautiful permanent blue pigment, until recently obtained from the *lapis-lazuli*, or azure-stone. (See the article **AZURE-STONE**, where that process is described.) A method of forming ultramarine *artificially* has, however, been recently discovered by M. Gmelin. This gentleman was led to consider sulphur as the colouring matter of ultramarine, from an observation

made by M. Tasseart, that he had noticed a substance resembling ultramarine, which was found in a furnace used in the manufacture of soda. The following is the process by which we are told (in the *Annales de Chimie*, xxxvii. p. 109,) ultramarine may be infallibly prepared.

Pulverized quartz is to be fused with four times its weight of carbonate of soda, the mass dissolved in water, and then precipitated by muriatic acid: thus a hydrate of silica will be formed. A hydrate of alumina is now to be prepared, by precipitating alum by ammonia. These two earths are to be carefully washed with boiling water; the proportion of dry earth in each is then to be ascertained, by heating a small quantity and weighing it. The hydrate of silica used by M. Gmelin contained 56 per cent., and the hydrate of alumina 3.24 per cent.

As much hydrate of silica is then to be dissolved in a hot solution of caustic soda as it will take up, and the quantity determined; then such proportion is to be taken as contains 72 parts of an hydrous silica, and a quantity of the hydrate of alumina, equivalent to 70 parts of dry alumina added to it, and the whole evaporated together, being continually stirred until it becomes a damp powder.

This combination of silica, alumina, and soda, is the basis of ultramarine, and is now to be coloured by a sulphuret of sodium in the following manner. A mixture of two parts of sulphur with one part of an hydrous carbonate of soda, is to be put into a Hessian crucible, covered up, and then gradually raised to a red heat, until it is well fused; then the mixture is to be thrown, in very small quantities at a time, into the midst of the fused mass. As soon as the effervescence occasioned by the water in one portion has ceased, another portion is to be added. Having retained the crucible at a moderate heat for an hour, it is to be removed from the fire, and allowed to cool. It now contains ultramarine, mixed with excess of sulphuret: the latter may be separated by water. If sulphur is in excess, a moderate heat will dissipate it. If all the parts are not equally coloured, a selection should be made, and then the substance reduced to a fine powder.

This cheap artificial product is equal in brilliancy, clearness, and durability, to the mineral ultramarine, for which we paid, a few years ago, as much as five guineas an ounce; and it is now so extensively manufactured as to be capable of being substituted for cobalt, from motives of economy.

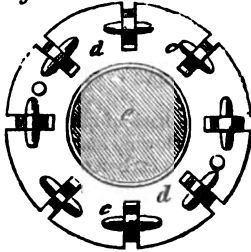
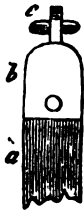
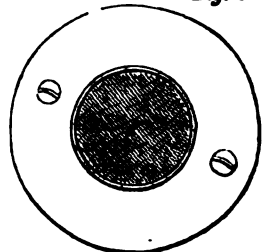
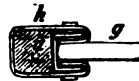
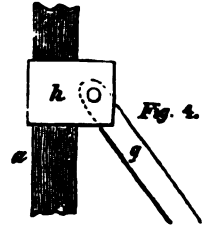
**UMBER.** A brown coloured earth, prepared as a pigment. See **PAINTING.**

**UMBRELLA.** A very light portable canopy, of a circular form, framed of radiating ribs of whalebone, or other suitable material covered with silk or cloth, and supported by a central staff over the heads of persons, to defend them from rain, or the scorching of the sun's rays. These well-known convenient machines have received but little improvement in their construction since their introduction into this country from the East, where they have been in use from time immemorial. British manufacturers have, however, by a series of trifling ameliorations, contrived to reduce the weight of them considerably; to give them more elegance of form, and a more perfect and durable action, considering their slender substance, and the delicate materials of which they are made, than they had previously attained: and all these ameliorations have been effected, together with a reduction of cost equal to fifty per cent.

Our readers will have noticed, that in umbrella frames of the usual construction, the ends of the whalebone are connected to the top of the umbrella by means of a *ring* of wire, and that the ends of the stretchers are in like manner jointed to the sliding-tube, which is evidently a very unmechanical arrangement, however cheap and easy of execution it may be; for the axes upon which these parts turn, instead of being straight lines, are the arcs of a circle, by which the friction is so excessive and unequal, as to insure the speedy destruction of these essential parts, and an early dismemberment of the whole machine. In old frames, it will likewise be noticed that the stretchers are connected to the middle of each whalebone by pins passing through the latter; the holes for these pins of course weaken the whalebones exceedingly, and the subsequent wear of these parts reduces their thickness so much, that they are frequently breaking;

and the repairs required, from one cause or another, are the source of much inconvenience in rainy weather.

To obviate these defects, each whalebone in Mr. Caney's patent umbrellas is connected to the top by separate straight axes, and in such a manner, that they cannot shift themselves out of their places; the stretchers on the sliding-tube are connected in the same way to the sliding-tubes; and the stretchers are jointed to the whalebones without perforating the latter, as will be understood upon reference to the annexed figures: wherein *Fig. 1* shows one of the ends, *a* of the whalebones, *b* the ferrule on it, with a pin *c* passing through its jointed end. *Fig. 2* shows a plan of the brass plate,—*d* being a plate to which the

*Fig. 2.**Fig. 3.**Fig. 1.**Fig. 5.**Fig. 4.*

whalebones are jointed; *e* is the aperture through which the umbrella stick passes; *c c* denote the pins or axes passing through the joints, and lying imbedded in cavities in the plate, wherein they are confined by the screws of the top brass-plate, shown by *Fig. 3*. The stretchers being jointed to the sliding-tube in the same manner as before mentioned, need no illustration. *Fig. 4 a* is one of the eight radiating whalebones; *h* a ferrule made by the doubling of sheet brass around it, to receive the pin or axis of the stretcher *g*, without impairing the whalebone; and the manner of doing this is shown in the transverse section in *Fig 5*, in which the same letters of reference indicate similar parts as are already described.

The construction of Mr. Deacon's patent umbrella is in some respects similar to Mr. Caney's. The ends of the ribs in the former have dovetailed caps, these dovetails entering recesses or notches in a cap, wherein they are confined by a plate, which is screwed down upon the whole. Instead of solid sticks, Mr. Deacon makes them of metal, hollow, and covers them with cloth varnished over, or with a coating of papier mache, impressed with ornamental designs. These coverings to the metal are intended to prevent the unpleasant and destructive effects of oxidation of the metal.

A patent was also recently taken out by Mr. J. G. Hancock, of Birmingham, for making light elastic rods for umbrellas, whips, &c., in the following manner. Willow rods of a suitable length have the pith contained in them bored out, and in its place are put metallic wires or rods. The wooden exteriors are then reduced, by planes or other suitable tools, to the required shape; afterwards, they

are coloured and varnished, to give them the appearance of whalebone. One end of the rods is capped with metal tips, the other end has the wires extending a little beyond the wooden cases, which are flattened and drilled to receive the wires that fasten them to the handles, and forms the joint on which they turn. Numerous other patents have been taken out for improvements in umbrellas, chiefly by the Birmingham manufacturers, for the metallic portion of the apparatus, termed the "furniture," and the extremely low price at which it is manufactured, is a matter of astonishment to those who are unacquainted with the facilities of the workshops.

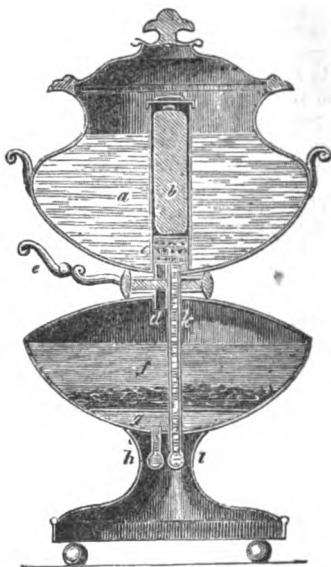
**URANIUM.** A metal discovered by Klaproth in 1789, in the mineral called *pech blende*. In this, it is in the state of sulphuret. But it likewise occurs as an oxide in the green mica, or uranglimmer, and in the uranochre. In obtaining it from *pech blende*, the mineral is reduced to a fine powder, and digested in a nitric acid till every thing soluble is taken up. The solution is then rendered as neutral as possible by evaporation, and a current of sulphuretted hydrogen gas passed through it as long as any precipitate continues to fall. The liquid is filtered and heated, to drive off all traces of sulphuretted hydrogen. It is now precipitated by caustic ammonia; and the precipitate, after being well washed, is digested, while still moist, in a rather strong solution of carbonate of ammonia. A fine lemon-coloured liquid is obtained, which being set aside for a few days, deposits an abundance of fine yellow crystals, in rectangular prisms. These crystals being exposed to a red heat, give out water, carbonate of ammonia, and oxygen gas, and leave a black oxide of uranium, which is easily reduced to the metallic state, by passing a current of hydrogen gas over it, placed in a glass tube, and heated by a spirit-lamp. The metal presents a liver-brown colour, and remains in the state of powder, being incapable, according to some authors, of reduction by any heat that can be applied to it. Dr. Ure, however, informs us that 50 grains, after being ignited, were formed into a ball with wax, and exposed in a well closed charcoal crucible to the most vehement heat of a porcelain furnace, the intensity of which gave 170° on Wedgwood's pyrometer. Thus a metallic button was obtained, weighing 28 grains, of a dark grey colour, hard, firmly cohering, finely grained, of very minute pores, and externally glittering: specific gravity, 8.1. A sulphuret of uranium has been formed, which has a black colour, and, when rubbed, a metallic lustre. Its capacity for forming alloys with other metals remains uninvestigated, in consequence of the scarcity of the metal. The oxides of uranium are used in painting upon porcelain yielding a fine orange colour in the enamelling fire, and a black one in that in which the porcelain itself is baked.

**URN.** A vessel of a vase or pitcher-like form. The vessels employed to keep water boiling at the tea-table, have thus been called tea-urns, notwithstanding every possible deviation has been subsequently made in their figure. The construction of ordinary tea-urns are too well known to our readers to require elucidation, but we shall here present to their notice one that possesses some claims to novelty, which must, however, be regarded rather as an elegant article of luxury, than one of great utility. This is Sharp's patent tea-urn, combined with a tea-pot in one vessel.

The engraving on page 832 represents a vertical section: *a* is the ordinary urn or vessel that holds the water; *b* the red-hot heater in its case; below the bottom of the case, the tube is prolonged so as to form a small chamber underneath, which is perforated at its sides with minute holes, through which the water passes by a tube *d* into the vessel *f*, when the valve (shown in the figure as closed) is opened by turning the lever *e*. The infusion is represented by the unbroken straight lines at *f*, and the tea leaves by dark looking masses, lie upon a grating or perforated bottom, through which passes clear to the lowest chamber *g*, from whence it is drawn off, as wanted, by a tube and cock, seen only in section at *h*. The plain water is drawn from the vessel *a* by means of the long tube *k* (which passes directly through the tea chamber) and a cock at *l*, also viewed only in section. It should now be observed that both the cocks *h* and *l* are inclosed in one tube or case, but they are united externally into

one, but provided with two lever handles, the handle on the left applying to the tea-cock, and that on the right to the water-cock.

It is a common remark, that tea made from the water in an urn is never so good as that supplied directly from a tea-kettle, on account of the difficulty of keeping the water boiling in the urn. To remedy this defect, we



submit to tea-urn makers a different arrangement. Let the vessel be placed above the water vessel, (not in it) and the metallic supports which connect the two vessels would conduct sufficient heat to keep the infusion at a proper temperature. Underneath the water-vessel burn a small spirit-lamp, instead of inserting the red-hot heater, which is a very inconvenient, and by no means an economical mode of heating.

## V.

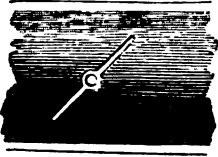
**VACUUM.** A space devoid of all matter. See AIR-PUMP, STEAM-ENGINE, and GAS-ENGINE.

**VALVE.** A cover or stop to an aperture, to control or direct the course of fluids. They are usually contrived so as to be readily opened by a small force acting on one side, and to be perfectly closed by a force when acting on the opposite side; and thus either admit the entrance of a fluid into a tube or vessel, and prevent its return; or else permit the fluid to escape, and prevent its re-entrance.

Valves are members of the utmost importance to steam-engines, pumps, and a variety of pneumatic, hydraulic, and hydrostatic machinery; and they are constructed in a great variety of forms, to adapt them to their several uses. Cocks employed for drawing off liquids are strictly valves; but this class of valves we have described under their usual distinctive name. (See COCKS.) Numerous valves have been described in different parts of this work, under

the above-mentioned subjects, we shall therefore notice in this place several varieties which have not been elsewhere specified.

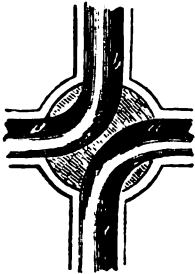
*Throttle-valves* usually consist of a thin disc, or circular plate of metal which entirely crosses the area of the steam-pipe, when closed, being supported by an axis or spindle, which passes diametrically through, or across it, and into the sides of the pipe. This spindle is either operated upon by the governor of the engine, or by hand, setting it open to such an extent as to intercept more or less of the steam in its passage to the engine.



*Field's Regulating Valve*, is a contrivance introduced by Mr. Joshua Field, of the firm of Maudslay and Co.; the object of which is to regulate the supply

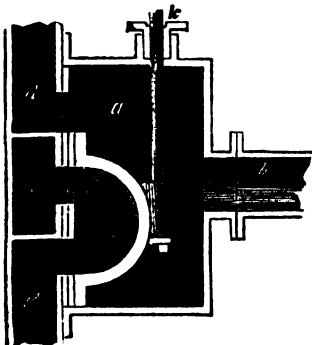
of the steam in a superior manner to the throttle-valve last described. "It consists," says Mr. Tredgold, "of a valve, placed in the situation usually assigned to the throttle-valve, that is, near to the place where the steam is admitted to the cylinder. This valve is to be opened at once, at the commencement of the stroke, so as to afford full passage to the steam, and shut at once, after a certain part of the stroke is made, that the rest of it may be completed by the power of the steam." Thus, by causing the valve to be shut sooner or later during the stroke, the power of the engine may be regulated.

One of the earliest and simplest contrivances for completely reversing the direction or course of steam, water, or other fluids, is the four-way cock. It was adopted by Leupold, upwards of a hundred years ago, and has been subsequently applied in very numerous instances; particularly by Mr. Trevithick, in his locomotive high-pressure engines, and by most of the locomotionists of the present day. The annexed cut exhibits a vertical section



of a four-way cock, considered as applied to a steam-engine: at *a* is represented the communication with the steam-pipe from the boiler; *b*, the passage to the upper side of the piston; *c*, the passage to the lower side of the piston; and *d*, the passage to the condenser. In the position represented, the steam is entering the upper part of the cylinder, and the lower part is open to the condenser; but if the plug, or central movable portion of the cock be moved one quarter of a revolution in either direction, then the steam is opened to the lower part of the cylinder, and the upper part is open to the condenser.

*The D slide-valve* is another invention of great simplicity, and has been much used for opening and changing the communications with the steam cylinder.



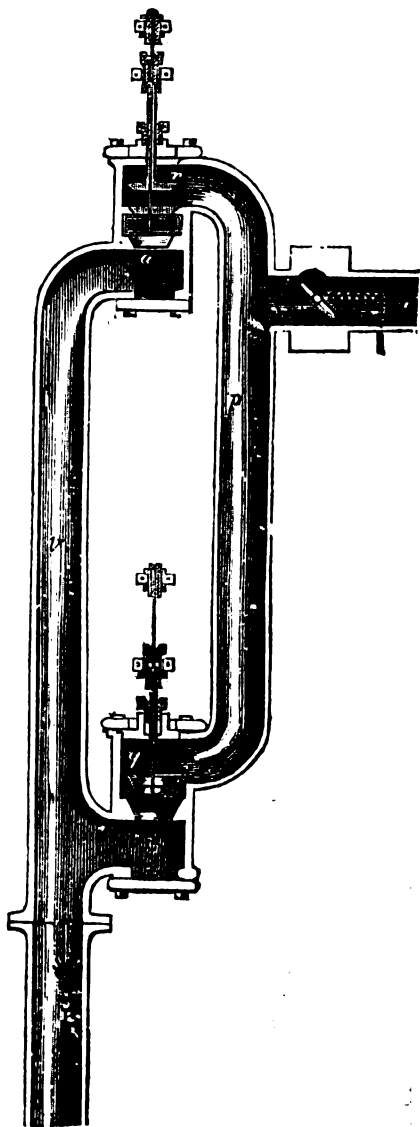
In the annexed vertical section, *a* is the steam-box, into which steam is admitted by the passage *b*. This box is bolted to a pipe, divided into three compartments; viz. *d*, a passage leading to the upper side of the piston; *e*, a similar passage to the under side of the piston; and *f*, a passage to the condenser. The apertures of this passage are faced with brass, and the space between each opening it is essentially necessary should not be less than each opening; *g* is a block of metal with a cross cast into it, equal in length to two of the apertures and the space between them; the block is generally faced with brass, and grooved upon the pipe, so as to slide over it steam-tight; it is moved by a rod, which passes through a stuffing-box *k*. In this position of the slide, the steam would pass through *d* to the top of the piston, whilst the steam beneath the piston would

through a stuffing-box *k*. In this position of the slide, the steam would pass through *d* to the top of the piston, whilst the steam beneath the piston would



pass through *e*, to the eduction-passage *f*. On raising the slide, *d* becomes open to the eduction-passage, and *e* to the steam.

The D slide, and the four-way cock, however, equally possess a great defect, that of wasting the steam that fills the passages of the movable portion of the



valves. Watt, Hornblower, Murdoch, and other steam mechanics, devised modifications of the D and other valves, by which the waste of steam was nearly obviated. The invention of Mr. Murray in 1789, for the same purpose, 1789

very high in our estimation, being attended with less friction than the others ; we accordingly give it insertion in this place.

*o* in the foregoing figure, is the pipe conveying steam from the boiler, and delivering it into the descending pipe *p*, which terminates in the valve *q*, opening to the lower part of the cylinder, by the side opening, marked as a shaded parallelogram, while the valve *r* opens a similar communication with the upper part of the cylinder ; so that, by the successive opening and shutting of *q* and *r*, steam is admitted above and below the piston. *s* is the lower end of the eduction-pipe, joining on to the condenser, and this pipe opens first to the lower part of the cylinder by the valve *t*, and leads also by a perpendicular continuation of the same pipe *v*, to a valve *u*, by which a connexion is formed with the upper part of the cylinder. The two apertures into the cylinder, called nozzles, are therefore common both to the admission of steam and the formation of a vacuum, which is regulated simply by the working of the valves. For as the figure now stands, *r* is the only open valve in the steam-pipe ; consequently steam would enter above the piston to depress it, while a vacuum would exist below it, on account of the valve *t* being open to the condenser. As soon as the piston reaches the bottom of the cylinder, the valves *r* and *t* must be shut, and *u* and *q* opened ; when the steam, being no longer able to get through *r*, would pass down the pipe *p*, and enter the lower part of the cylinder through *q*. Meantime *u* being opened to the condenser by the pipe *v*, would cause the necessary vacuum above the piston to permit its ascent, which being completed, the valves must be again put into the position shown in the figure, to produce its descent, and so on. It will be sufficient to state that those valves are operated upon either by levers, passing in a steam-tight manner through the side pipes, or that sometimes the spindles of the valves are made to act one through the other, in stuffing, as in the present instance, when they are worked by external applications.

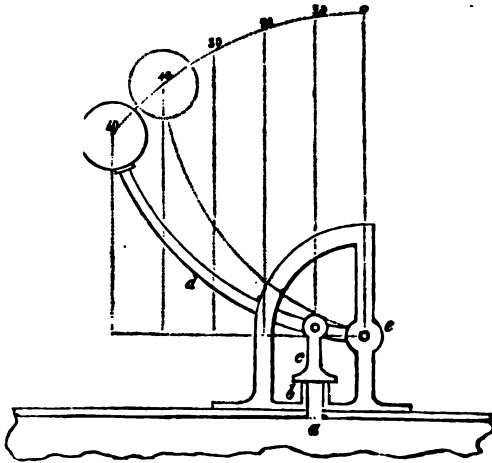
By this most ingenious contrivance no waste of steam arises, excepting in the small aperture between the valves ; and the friction is obviously much less than in either slides, cocks, or perhaps any other kind of valve ; the only resistance to their motion being the pressure upon the upper side by the steam, when in their seats. Their cost, compared to slide-valves, is much greater ; but as they are not liable to material wear, and work with great accuracy, the extra expense does not prevent their very general adoption in large engines.

Having thus briefly noticed a very important class of valves, we proceed to describe another kind, which have even stronger claims upon our attention, as will be immediately acknowledged by naming them,

*Safety-valves* ; these are well-fitted covers or stops to apertures made in the upper part of a boiler, and loaded to such a degree only as the steam will overcome when it exceeds the required pressure. The contrivance, in nearly its usual form, (the steelyard,) was invented by Dr. Papin, in 1684, as an appendage to his apparatus for dissolving bones by steam at high pressure ; but the first application of it to the steam-engine was by Savery. It received some improvement by Beighton in 1718, since whose time the same form continues to be used, as will be recognised in numerous steam apparatuses in various parts of this work. Mr. Tredgold, in his able work on the steam-engine, observes, that it would be a great improvement upon safety-valves, if they could be so constructed as to be relieved of a part of their load, when raised from their seat. With the view of effecting this object in the simplest possible way, we suggested many years ago, (see *Register of Arts, &c. for January, 1829*) the employment of a bent lever, instead of the straight one in common use, the action of which will be understood by reference to the subjoined diagram, wherein is also represented some other modifications of the safety-valve, which it is presumed are worthy the consideration of the practical man.

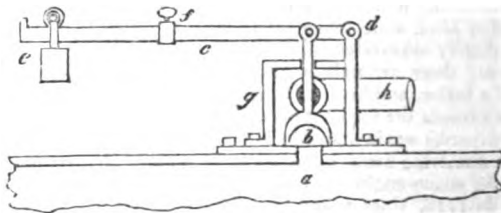
*a* represents an aperture in the upper part of a boiler ; over this aperture is fitted a short tube *b*, turned true at the top with a round edge, so that a steel plate *c*, flat and smooth on its under side, may touch at every part ; this steel plate is suspended by a joint, to a curved lever *d*, whose fulcrum is at *e*, and which is loaded at the other end with a weight of 10 pounds. Now, as the

lever has a power of five, (as shown by the five equal dotted spaces,) the plate *c* is pressed down upon the edge of *b*, with a force of 50 pounds; but when the lever and weight are raised, by the pressure of the steam, into the position shown by the dots, the force acting against the steam is reduced to 40 pounds;



and, in proportion to the force of the rush of the steam, by which the lever would be raised higher and higher, would the resistance be reduced to 30, 20, &c. as marked. This valve might be enclosed as usual, in a box, with a pipe to conduct off the waste steam.

The subjoined diagram is explanatory of another mode of producing a similar result, but by different means; *a* is the aperture in the boiler, on which is fixed



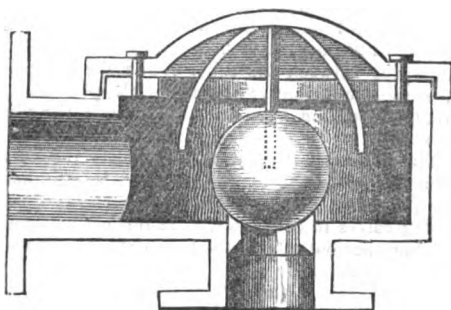
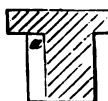
a gun-metal plate or valve seat; *b* is a steel cup-valve, turned rounding at the edges, resting on the seat, and suspended to a straight lever *c*, whose fulcrum is at *d*. At *e*, is the weight suspended to the axle of a little wheel, which is made to traverse freely the upper side of the lever *c*, but whereon its range may be limited by means of a sliding stop *f*, provided with a set screw. *g* is the valve box, and *h* a pipe to carry off the waste steam. It will now be obvious that when the steam lifts the valve, the load on the lever will move towards the fulcrum to any extent desired, and thus the boiler may be relieved in proportion to the exigency of the case. It scarcely need be remarked, that our reason for making the valves with edges pressing upon flat surfaces, was to prevent the possibility of their sticking in their seats; which, with the conical plug-valves, is a common occurrence, and one that has been productive of serious accidents.

The safety-valves employed by Woolf, are calculated to prevent adhesion to

their seats, and are of great simplicity; their form is represented in the margin, *Fig. 1* being a plan, and *Fig. 2* a vertical section. The shape may be considered at first as a solid cylinder with a circular plate at top; three large longitudinal grooves, as shown at *a a a*, reduce the cylinder to the figure represented. The plug thus made, fits easily into the aperture of the boiler, and the steam which fills the grooves, pressing against the under surface of the head, raises the plug and escapes. The plug is loaded either by a weight, suspended to it inside the boiler, by weights laid directly upon the top, or by the agency of a loaded lever.

In a letter to the editor of the *Leeds Mercury*, Mr. Benjamin Hicks, of the steam-engine manufactory at Bolton, in Lancashire, says, "I am induced, in order to prevent the accidents occasioned by the bursting of steam-boilers, which are of such frequent occurrence, and generally so dreadful in their consequences, to send to you the drawing and description of a self-acting safety-valve, of my invention, (or rather application to a new purpose; a similar valve having been used as a clack for a pump, upwards of a hundred years ago.) You will readily perceive, from the several advantages it possesses, that wherever its adoption shall take place, it would scarcely be possible for an accident of this nature to arise.

"The opening in the lower part of the box, which is fixed on the boiler-top, or, if more convenient, on any part of a pipe having a free communication with it, requires to be of such a size, as to allow a free discharge of all the steam the boiler is capable of generating. This opening is covered with a spherical valve,

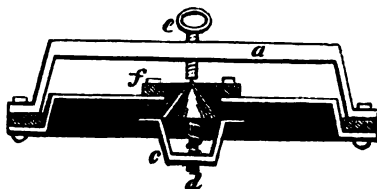
*Fig. 1.**Fig. 2.*

(the outer part of which is brass, filled with lead,) of such a size, and consequently weight, as to press with as many pounds per square inch, as it is intended the strength of the steam, at a *maximum*, in the boiler, should ever be raised to; the obvious effect of which will be (*owing to its being perfectly free from friction*), that, at the very instant the steam arrives at that degree of pressure, the ball will be raised, and a discharge instantly take place. The projections are merely to prevent the ball, at any time from falling off its seat.

"From the nature of its construction, requiring no packing or attention, it can be entirely secured from the interference of careless attendants, and a pipe may be attached to the branch of the box, and continued into the chimney, or any other convenient place of discharge. I should not recommend this valve to be used as a substitute for the ordinary safety-valve, (improperly so called,) but in all cases in addition, and so loaded, as only to be brought into action at a very trifling additional pressure above that, to which the other valve is weighted. This valve would be found of the greatest advantage, in preventing the boiling over of the feed-pipes of boilers, when the rooms over them are used as drying-stoves in print-works, bleach

"I ought to state that I have had this description of valve in use for upwards of four years, with the greatest regularity of action."

Another valve, of a very peculiar description, and especially adapted to afford security against explosion in large boilers, was invented by Mr. Sockl, of Lambeth, who received an honorary reward from the Society of Arts, for the communication of the invention. It is represented in the subjoined cut.



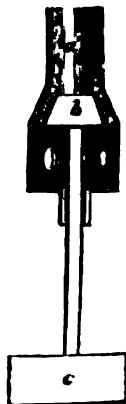
Instead of the lid which covers the main hole, a copper plate or dish is to be substituted, as shown in the darkened part of above figure: this copper dish is surrounded by a ring of the same metal, by which the plate is firmly screwed down upon the rim of the main hole. In the middle of the plate is fixed the valve, of which *f* is the collar, made of iron or brass; *d* the plug, which is ground air-tight into the collar, and is kept in its place by the spiral spring which surrounds its stem, and the stay *c*: over the whole is fixed a cross-piece *a*, which is firmly screwed down upon the ring that secures the dish. In the cross-piece, works the regulating screw *e*, which may be screwed down upon the head of the plug.

The operation of the valve is easy to understand. The copper dish is only about one-fourth the thickness of the other parts of the boiler, and will not therefore afford the same resistance to the steam: when this, therefore, gets beyond the ordinary pressure, it will cause the dish to become somewhat convex, and will thus leave a clear space between the collar *f*, and the conical plug *d*, for the steam to escape; as soon as the power diminishes, the plate will, by its elasticity, return to its former place, and by closing down upon the plug, prevent any further escape of steam.

The object of this valve is not so much to regulate the working pressure of the steam, as to act in aid of the common valve, by affording an additional aperture, in case the steam should acquire a dangerous degree of force. It differs from the plug-valves in common use, in this circumstance, namely, that in the latter, the plug rises out of its socket, in order to allow of a vent for the steam, whereas in Mr. Sockl's, the socket rises away from the plug. The chief advantage resulting from this is, that if any adhesion should have taken place between the plug and the socket, it is more likely to be overcome, on account of the great surface of the socket, with its attached copper plate, which is exposed to the action of the steam.

A substitute for the common ball-cock, used for regulating the height of liquids in reservoirs, has been introduced by Mr. Darnall, of Pentonville, the construction of which is exhibited in the annexed section: *a* is the supply pipe, *b* the valve, (shut,) *c* a float connected to the valve by an upright spindle. As the water is drawn off, the float descends from its seat into the chamber beneath, allowing the water to pour through the apertures shown, into the reservoir; the float, as it rises again with the water in the reservoir, closes the valve, and shuts off the supply of water, when it has attained its proper elevation.

We shall here close the article upon valves, referring the reader to the machinery before mentioned for further elucidations, and likewise to the article WATER-CLOSET, which mainly consists of valves of a very ingenious construction.



**VANADIUM.** A newly discovered metal by M. Sefstrom. It has been briefly described in a letter from M. Berzelius to M. Dulong, from which the following is an extract :—" M. Sefstrom, director of the School of Mines at Fahlun, whilst engaged in examining a variety of iron, remarkable for its extreme softness, observed the presence of a substance, the properties of which differed from all other known bodies, but its quantity was so small as would have rendered it tedious and expensive to collect sufficient for a correct examination of its properties. This iron was from the mine of Taberg, in Smoland; the ore merely contained sources of the substance. Finding that the pig iron contained far more of this principle than the wrought iron, M. Sefstrom thought that the scorix formed during the conversion of the pig iron into wrought metal might be a more abundant source; a conjecture confirmed by experience; so that sufficient having been procured, he went to M. Berzelius to complete its examination."

Vanadium combines with oxygen to form an oxide and an acid. The acid is red, pulverent, fusible, and on solidifying becomes crystalline. It is slightly soluble in water, reddens litmus, and forms yellow neutral salts, and orange bisalts. Its combinations with acids or bases have the singular property of suddenly losing their colour; they resume it only on becoming solid again, and being then re-dissolved, preserve their colour. Hydrogen at a white heat, reduces vanadic acid, leaving a coherent mass, having a feeble metallic lustre, and being a good conductor of electricity, but it is not certain that the reduction is complete. The oxide of vanadium is brown, or nearly black, and dissolves readily in acids. The salts are of a deep brown colour, but by the addition of a little nitric acid, effervesce and become of a fine blue colour. The oxide and acid of this metal together produce other combinations, green, yellow, and red, all soluble in water.

When the oxide of vanadium is produced in the humid way, it is soluble both in water and alkalis. The presence of a salt renders it insoluble, and upon this effect may be founded a process for its preparation. Before the blow-pipe, vanadium colours fluxes of a fine green, in this respect resembling chrome.

**VAPOUR**, from the circumstances of its formation, may be considered to consist of extremely minute vesicles of water or other fluid, inflated with air. See **STEAM**, **ALCOHOL**, &c.

**VAPOUR-BATH.** A closet or room, in which a person exposes his body to the action of vapour introduced by a pipe from a boiler. See **BATH**.

**VARNISH.** A solution of resinous matter, which, laid upon the surface of solid bodies, becomes hard, glossy, impervious to moisture, and gives beauty and durability to them. Under the several heads of **LAC**, **COPAL**, **MASTIC**, **СЛОУТНОУС**, and other resins, we have described the process of preparing varnishes from them; we shall therefore in this place take a general, but concise view of the subject. The solvents are either expressed or essential oils, as also alcohol. For a lac-varnish of the first kind, the common painter's varnish is to be united by gently boiling it with some more mastich or colophony, and then diluted again with a little more oil of turpentine. The latter addition promotes both the glossy appearance and drying of the varnish; of this sort is also amber varnish. To make this varnish, half a pound of amber is kept over a gentle fire in a covered iron pot, in the lid of which there is a small hole, till it is observed to become soft, and to be melted together into one mass. As soon as this is perceived, the vessel is taken from off the fire, and suffered to cool a little; when a pound of good painter's varnish is added to it, and the whole suffered to boil up again over the fire, keeping it continually stirring. After this it is again removed from the fire; and when it is become somewhat cool, a pound of oil of turpentine is to be gradually mixed with it. Should the varnish when it is cool happen to be yet too thick, it may be attenuated with more oil of turpentine. This varnish has always a dark brown colour, because the amber is previously half burned in this operation; but if it be required of a bright colour, amber powder must be dissolved in transparent painter's varnish, in Papin's machine, by a gentle fire.

As an instance of the second sort of lac-varnishes with ethereal oils alone, may be adduced the varnish made with oil of turpentine. For making this, mastich alone is dissolved in oil of turpentine by a very gentle digesting heat, in close glass vessels. This is the varnish used for the modern transparencies employed as window-blinds, fire-screens, and for other purposes. These are commonly prints, coloured on both sides, and afterwards coated with this varnish on those parts that are intended to be transparent. Sometimes fine thin calico, or Irish linen, is used for this purpose; but it requires to be primed with a solution of isinglass before the colour is laid on. Copal may also be dissolved in genuine Chio turpentine, according to Mr. Sheldrake, by adding it in powder to the turpentine previously melted, and stirring till the whole is fused. See COPAL.

A varnish of the consistence of thin turpentine is obtained for aerostatic machines, by the digestion of one part of elastic-gum, or caoutchouc, cut into small pieces, in thirty-two parts of rectified oil of turpentine. Previously to its being used, however, it must be passed through a linen cloth, in order that the undissolved parts may be left behind. See CAOUTCHOUC.

The third sort of lac-varnishes consists in the spirit-varnish. The most solid resins yield the most durable varnishes; but a varnish must never be expected to be harder than the resin naturally is of which it is made. But the most solid resins by themselves produce brittle varnishes; therefore something of a softer substance must always be mixed with them, whereby this brittleness is diminished. For this purpose gum-elemi, turpentine, or balsam of copaiva are employed in proper proportions.

The celebrated "French polish" is effected by a spirit-varnish, treated in a peculiar way. The following mode of preparing and using it may be relied upon as genuine, being extracted from that very accurate French work, the *Dictionnaire Technologique*. The varnish is composed of

Gum Sandarach . . . . .	14 oz. & 2 drachms.
Gum Mastic in drops . . . . .	7 " 1 "
Shell-lac (the yellower the better) . . . . .	14 " 2 "
Alcohol, of 0.8295° spe. gra. . . . .	3 quarts & 1 pint

The resinous gums are to be pounded, and their solution effected by continued agitation, without the aid of heat. When the woods to be varnished are very porous, 7 ounces and 1 drachm of Venice turpentine. In order the better to divide the resins, and to cause them to present a greater surface to the action of the alcohol, they should be mixed with an equal weight of ground glass; the latter preventing the dust of the resin from forming clots, the solution is thus easier made, and in less time. Before applying the varnish, the wood should be made to imbibe a little linseed oil; it must then be rubbed with old flannel, in order to remove the excess of oil; blotting paper may be used for the same purpose, or finely-sifted saw-dust. Afterwards the varnish should be applied, by saturating with it a piece of old soft coarse linen cloth, many times folded into a sort of cushion, and rubbing it softly on the wood, turning the linen from time to time until it appears nearly dry. The linen should be saturated afresh with varnish, and the rubbing be continued in the same manner, until the pores of the wood are completely filled. Care should be taken not to make the linen too wet, nor to rub too hard, especially at the beginning of the operation. When the varnish sticks, or becomes tacky, a very small drop of olive oil is to be applied with the end of a finger, uniformly all over the cushion. The finishing is effected by pouring a little pure alcohol upon a piece of clean linen, which is lightly rubbed over the varnished wood; and as the linen and the varnish dry, the wood is rubbed more briskly, until it takes a beautiful polish like a looking-glass. Two or three coatings of varnish are sufficient for woods not very porous.

A fine colourless varnish may be obtained, by dissolving eight ounces of gum-sandarach and two ounces of Venice turpentine in thirty-two ounces of alcohol by a gentle heat. Five ounces of shell-lac and one of turpentine, dissolved in thirty-two ounces of alcohol by a very gentle heat, give a harder

varnish, but of a reddish cast. To these the solution of copal is undoubtedly preferable in many respects. This is effected by triturating an ounce of powder of gum-copal, which has been well dried by a gentle heat, with a drachm of camphor, and, while these are mixing together, adding by degrees four ounces of the strongest alcohol, without any digestion. Between this and the gold varnish there is only this difference, that some substances that communicate a yellow tinge are to be added to the latter.

Oil-varnishes are commonly mixed immediately with the colours, but lac or lacquer-varnishes are laid on by themselves upon a burnished coloured ground: when they are intended to be laid upon naked wood, a ground should be first given them of strong size, either alone, or with some earthy colour mixed up with it by levigation. The gold lacquer is simply rubbed over brass, tin, or silver, to give them a gold colour. (See LACQUER.) The coloured resins or gums, such as gamboge, dragon's-blood, &c., are used to colour varnishes.

The essential varnishes consist in a solution of resin in oil of turpentine. The varnish being applied, the essential oil flies off, and leaves the resin. This is used only for paintings.

Before a resin is dissolved in a fixed oil, it is necessary to render the oil drying. For this purpose the oil is boiled with metallic oxides, in which operation the mucilage of the oil combines with the metal, while the oil itself unites with the oxygen of the oxide. To accelerate the drying of this varnish, it is necessary to add oil of turpentine. When resins are dissolved in alcohol, the varnish dries very speedily, and is subject to crack; but this fault is corrected by adding a small quantity of turpentine to the mixture, which renders it brighter, and less brittle when dry.

**VELVET.** A rich kind of silk or cotton cloth. See WEAVING.

**VENEERING.** The art of fixing, in a firm and durable manner, very thin leaves of a fine or superior wood, over a coarse or inferior wood; so as to give the latter the appearance of a solid mass of the former. The thin leaves are called veneers, and are cut from the logs by fine saws, now usually worked by machinery. See SAWING-MACHINERY.

Inlaid work is effected by veneers cut into suitable pieces, for the purposes. The thickness of veneers is from a tenth to a twelfth part of an inch. When the dimensions of these have been nicely adjusted to the work in hand, they are glued down; and, that the work may be solid, they are put into a press made for the purpose, or are held down by planks and poles, abutting against the beams of the workshop. When the glue is thoroughly dry, the work is taken from the presses, and finished by smoothing-planes, scrapers, fish-skin, &c., and afterwards polished by shave-grass and brushing, waxing, varnishing, &c., according as it may be required.

**VENTILATION.** The act of renovating the air of chambers, houses, ships, and all kinds of buildings or places. We may exist for several days without food, but we die, if deprived only for a few minutes of air. As air is necessary to life, so is pure air to health. But it appears that this important fact escapes the attention of the greater part of mankind, who are prone to blame the cook or the purveyor for the greater part of their ailments, without reflecting upon the impure air they may have been inspiring at the rate of about two gallons per minute. The oxygen gas, or vital portion of the atmosphere that enters the lungs, is changed at each respiration into carbonic acid gas. This gas, as is well known, is poisonous, if inspired alone, or even if a large proportion of it be mixed with the atmospheric air. But by an admirable provision of the great Author of Nature, this contaminated air is rendered specifically lighter than the pure atmosphere, from the heat it has derived from the lungs, and consequently rises above our heads, during the short pause between our respirations; thus insuring to us always a pure draught of air, unless we prevent it by artificial means.

It is not, however, always owing to a deficiency of oxygen, that the air of rooms or crowded places becomes pernicious to health. A council of health, established by the French government, proved that in an atmosphere which had not lost one-twentieth part of its oxygen, an animal miasmata was diffused in



vapour; that by suspending, in such atmospheres, a glass vessel filled with ice, the vapour diffused in the air becomes condensed on its surface, and the liquid thus obtained by condensation, being collected in another vessel suspended underneath the former, exhales a fetid odour, and speedily undergoes the putrid fermentation, when exposed to a temperature of 79° Fahr.

Certain gaseous and other vapours may be mixed with the air we breathe, without producing any very marked inconvenience; but the effects of a mixture of many other kinds are highly dangerous, and more quick in their action than even those of animal miasmata. A constant renewal of the air is absolutely necessary for its purity; for in all situations, it is suffering either by its vital part being absorbed, or by impure vapours being disengaged and dispersed through it. Ventilation therefore resolves itself into the securing a constant supply of fresh air. Rooms cannot be well ventilated, that have no outlet for the air, and this, from the superior levity of foul air, should be made at the highest point that can be obtained, and so arranged as to diffuse the fresh air that enters over the upper part of the room, and not inconvenience the persons in the room, by descending upon them in a current. There should be a chimney to every room, which on no account should be stopped up with a chimney-board, as is often the case in bed-rooms. We have observed also, in many houses, that the top sashes of windows of the upper rooms are made fast; now if these were made to slide downward, instead of the lower sashes upward, increased salubrity, as well as security, (especially in the case of children,) would be obtained. In whatever way fresh air may be made to enter an apartment, it should be, as far as may be practicable, at the part remotest from the fire-place, in order that it may traverse the whole apartment in its passage to the chimney. The most effective species of ventilation is that in which nature is adopted as the guide. The simple action of the sun, no less than the devastating phenomena of the African tornado, tend to the same result. We have only to change the temperature of the air which surrounds us, and a new portion will rush in from the adjacent and purer parts, to supply its place. From this it is obvious, that a lamp placed in an aperture of the ceiling, in any large and crowded room, will tend to purify the air. This is precisely the case in our large theatres, as that at Covent Garden, where the great glass chandelier, with its numerous gas-burners, gives out a great quantity of heat, immediately under a large funnel, which passes through the roof, into the open air. The rarified air which thus rushes through the funnel, is constantly succeeded by continuous fresh currents, entering at numerous apertures beneath, to restore the equilibrium of pressure.

Notwithstanding this arrangement is calculated to render the atmosphere of crowded places more fit for respiration, it is productive of a painful and serious inconvenience to those persons who may be situated near to the apertures before-mentioned, where the fresh air enters; they are thus exposed, as it were, to the action of a series of blow-pipes, and the consequences are, colds, asthmas, and rheumatisms, in abundance. To avoid drafts, and yet ventilate thoroughly, has hitherto been found of difficult accomplishment. In "A letter to the Earl of Chichester, on the practicability of rendering those properties of air, which relate to caloric, applicable to new and important purposes, (1823)," by Mr. John Vallance, of Brighton; that gentleman has proposed a plan for warming and ventilating the Houses of Parliament, which, in principle, is admirably designed to obviate the difficulties just mentioned; we shall, therefore, give it a place here in the author's own words; although there are some mechanical difficulties to be overcome, before it can be rendered elegant and convenient; the means of effecting which, will, we trust, be ultimately accomplished.

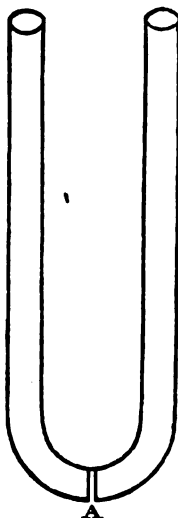
"There are two principles which operate to alter the state of air, in any place where numbers of people convene. One of them affects it physically, and to a change of density, and is the cause of drafts and influxes of cold air; the other affects it chemically, and to a change of quality, as the medium by which the action of the lungs is rendered efficient to the preservation of life, and renders necessary, and indeed indispensable, the drafts and currents of which the first is the cause. The first of these occurs in every place in which air is heated; the other, only in those places in which it undergoes respiration. Now, it is

the first only of these that falls under our consideration, when investigating the principle on which drafts take place; and the course of operation of this principle is thus. If heat be communicated to a particle of air, a change takes place with respect to that particle in the following manner; it becomes expanded and increased in bulk, in some such way as may be conceived, by reference to the juvenile practice of holding a flaccid bladder before the fire, to tighten and fill it up again, prior to using it as a football.

By this expansion it is increased in bulk but not in weight; and in consequence, rises from among the other particles, and ascends towards the ceiling; in the same way that a bladder, filled with air, would rise through, and swim at the top of others filled with water, were they thrown into the sea together; and, as the only circumstance which caused this particle to be where it chanced to be at the time this supposed heating took place, was its gravity; the moment that becomes altered, and it, in consequence, rendered specifically lighter than the surrounding particles, it ascends, and passes through them towards the ceiling. This is the course of operation of the principle; the effect of it is this:—The moment this particle of air has moved away from what heated it, its place is taken by another, which, undergoing the same change, passes off in like manner, having its place taken by a third particle; and this alternation continues all the while heat is communicated, be the communicator what it may, whether the human body, a stove, or any other method of heating.

This is the effect of air's being heated; its physical state is altered, and it becomes specifically lighter than it was before.

The consequence of its becoming lighter, may be conceived thus:—If a glass tube were taken, shaped in this manner, with a notch or crevice cut in it at A, to which notch or crevice a metallic slide were well and tightly fitted, so as to cut occasionally off the communication between the two legs; if into this tube there were (when the slide was pushed in, so as to cut off the communication) poured, in one leg, quicksilver, and in the other water, and then, when both were full, (placing the thumb on the top of the leg that had the water in it, to keep it in,) the slide between the quicksilver and water were pulled out to let them press one against the other, it is very evident that the superior weight of the column of quicksilver would cause it to press the column of water upwards against the thumb, and that, were the thumb removed, the water would be driven up, and some of it forced out of the tube; and also, that the water would continue to rise, till the contents of the two legs counterbalanced each other. Now, this is an illustration of what takes place in any building, whenever the air inside it is hotter than the air without.

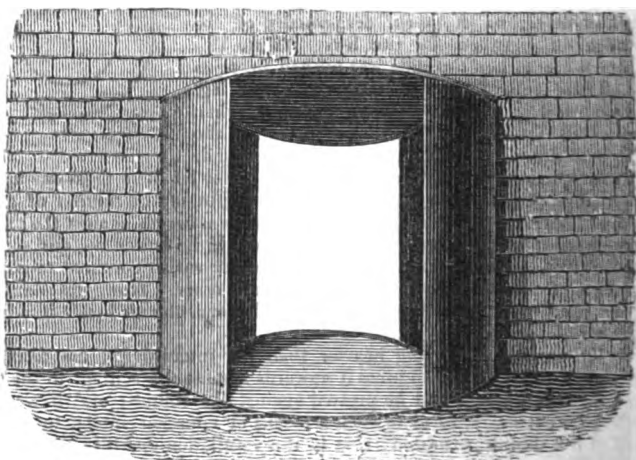


Since, the external air being heavier than the internal air, the former so operates upon the latter, as to press it upwards against the ceiling, in the same manner that the water would be pressed against the thumb; and if a part of the ceiling be cut away, so as to open a means of emission similar to what the removal of the thumb permitted; that is, if a ventilation aperture be opened in the ceiling, the superior weight of the cold external air will cause it to drive the lighter internal air up through that aperture, till the equilibrium becomes restored: and if, owing to the air on the inside being by the respiration, &c., of people convened in the building, kept constantly warmer and lighter than the external air, this equilibrium is prevented, and the difference between the external and interval atmosphere kept permanently up, the consequence then will be, that instead of a single and transitory emission, like that of the water from the tube, there will be a continuous emission of air through the ventilator,

all the while the respirations, &c., of those who are assembled in the building keep up the difference. Now this is what takes place in all public places; and as, owing to the door and windows being, during cold weather, kept shut, the aperture of admission (or channel by which the external air enters the building,) is rendered very much smaller than that of emission; to make up for the difference thus caused between the apertures of admission and emission, the cold external air is obliged to make use of all the cracks and crevices that are about either the doors and windows, or elsewhere around the building, and to introduce itself through them with a velocity so much greater than that at which it passes off by the ventilator, as will make up for the difference between the sizes of the cracks and crevices by which it enters, and that of the ventilation aperture.

This is the reason why drafts are experienced from the crevices of doors and windows: the heated and respired air passes off by the ventilator; to make up for what so passes off, fresh air flows into the bottom of the building, and as, when the weather is cold enough to make us shut the doors and windows, ingress by a duct equal to that of egress is prevented, to make up, by the rate at which it enters, for the difference in the sizes of the apertures of admission and emission. the air that finds its way in through cracks and crevices, enters with so great a velocity as to cause the chilling currents we experience.

Instead of suffering ventilation to take place at the pleasure of the air, I restrict and regulate it thus:—I first have the windows of the place nailed down, to prevent them from being ever opened; I then have the joints and crevices, both of these windows and of the room in general, so filled with putty, or so treated with any kind of lute or luting, that will answer the purpose, as shall prevent their becoming channels through which drafts or currents may find their way either into or out of the place. I then have the door-ways arranged thus:—Removing the present doors, the door-way is made six feet wide, by about the same height, and into it is fitted a cylinder (of wood or metal) closed at both ends, and placed upright on one of them, so as to appear somewhat like a cask



built into the wall. Through the side of this cylinder I have two apertures cut, each about four feet wide, by the height of the cylinder inside its ends; which apertures are opposite, the middle of each being in the line of the centre of the cylinder, so as to leave a way of about four feet wide, right through the middle of it into the place, as shown above, where the cylinder is represented placed in the wall, with the apertures in it. In the centre of the cylinder, there

is now put (perpendicularly) a shaft, of about three inches diameter and of the length of the cylinder; and having it, and the centres of the top and bottom of the cylinder, so prepared and fitted to each other, that the shaft may easily turn round, or revolve; then there are fixed on it, at right angles to each other, eight arms or radii, four at top, and four at bottom; the bottom four being exactly under the upper ones. To these arms there are fixed four sheets, or pieces of iron plate, of such lengths and widths as will just go into, and fill up, (though without touching,) the space left between the shaft and the side of the cylinder; and these things being so done, that the plates or leaves fixed on the arms may turn easily round, inside the cylinder; and the ends and sides of these leaves being so fitted to each other that, when the leaves are turned round, there may not be a space greater than about the sixteenth of an inch left between them, the arrangements for the door-way are complete; and the cylinder through which the place is entered, has within it four leaves or wings, somewhat like the fans of a winnowing-machine, fixed perpendicularly.

Now, the effect of these arrangements is this:—Were a common door to be made use of, whenever it was opened, free ingress or egress would be given to air, and it would pass from, or into the place, as circumstances dictated. But with a door arranged in this way, no air can at any time pass either into, or out of the place, excepting by the narrow space or crevice left between the edges of the leaves and the inside of the cylinder; since, the leaves being all at right angles with each other, and the two apertures in the cylinder being neither of them so wide as to be equal to ninety degrees of a circle of the same diameter as this door-way cylinder, it follows that, turn, or cause the leaves to revolve in what way we may, two of them will always be within the uncut parts of the cylinder, and constantly interposed between the inside of the place and the open air; and in consequence, there never can be any other passage for air into, or out of the place, by this door-way, than by the space or crevice between the edges of the leaves, and the inside of the cylinder.

When the windows and door are thus finished, I proceed as follows with the ventilator:—To the aperture in the ceiling, through which ventilation takes place, there is fixed a pipe of an equal diameter with that aperture; which pipe goes through the roof and then descends, and opens into a reservoir or cistern, situated on the outside of the building. Now, with things thus arranged, and with the cistern so far filled with water that the end of the ventilation-pipe is immersed a few inches in the water, the machinery by which the warm air is injected is set to work, when air, fresh, and of a temperature pleasant to the feelings, is injected into the bottom of the building, at a rate sufficient for the consumption of the people inside. The pipes which convey this air, are so contrived and arranged, as to distribute it over the whole surface of the floor, in a way which renders its introduction imperceptible; and consequently inconvenience from drafts or currents of it is guarded against. As fast as it is distributed over the floor, it gives place to the air that follows it, and rises towards the ventilator. In its ascent it passes the persons of the people in the place; and becoming, from the heat imparted to it by their bodies, and from the deteriorating effects of their respiration, lighter, it rises more rapidly towards the ventilator.

Now, from the arrangements and lutings I have mentioned, the only places where this air can find egress, are through the ventilation-pipe, and by the spaces or crevices between the door-way cylinder, and the leaves that revolve in it; and these spaces or crevices being, when the cylinder and leaves are well finished and fitted to each other, as almost nothing in comparison with the quantity of air injected, it follows that the ventilation-pipe must be the main channel of exit. But before any air can pass through this pipe, it must displace the water inside that end of it which is immersed in the cistern; to displace this, a slight pressure must be thrown upon it; the causing this pressure will somewhat condense the air in the ventilation-pipe; and as this condensation will, owing to that principle of fluids by which action and reaction are communicated, be reverted, or reflected back upon, and caused to take place with respect to all the air in the building, the whole of it will be somewhat condensed, and, in consequence, the building will have in it a quantity of air greater than

it would under common circumstances have, according to the depth to which the end of the ventilation-pipe is immersed in the water. Now, as this compressed state of the air, and the building's thus having within it more than it would under common circumstances contain, is contrary to the natural tendencies of air, its expansive principle will be exerted, and every crack and crevice about the place will become a channel to let air *out* instead of *into* it; and, in consequence, drafts *into* the building effectually prevented, owing to every cranny through which they used to enter, becoming a channel of *egress* instead of *ingress*.

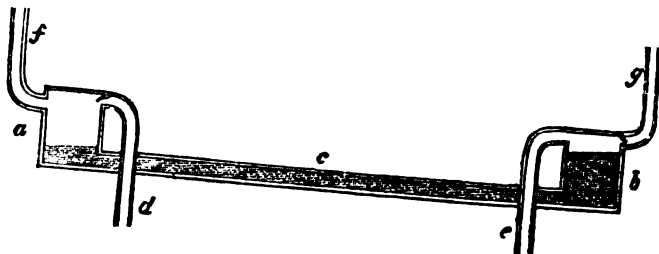
This is the way in which I prevent and do away with "*drafts*;" and when the door and ventilation apparatus (which is, in fact, nothing more than a most sensitive valve, and to which a valve would, under some circumstances, be preferable.) are well arranged, and their effect not counteracted by any of the cracks and crevices which are about rooms being suffered to remain unluted, or otherwise unstopped, the evil it is intended to remedy will be effectually done away with.

There is, to be sure, both singularity, and a degree of inconvenience, in a door-way such as I have described; though, by having the panels of the revolving-leaves of glass, this might be much done away with; and as there is no other equally convenient way of preventing all possibility of annoyance from the door, whenever any one either entered or went out of the place, it might be submitted to, should common doors not be considered sufficient.

With the prevention of inconvenience, and the danger of taking cold *inside* the building, would also be the removal of much of the liability to cold, &c., when leaving the now highly heated atmospheres of public places; as, owing to the temperatures being always uniform, and never above that which was agreeable and salubrious, much of the danger we all experience, and many of the indispositions people of delicate constitutions incur, in consequence of passing from those atmospheres to the open air, would be done away with. And, by varying the depth of the water, in which the ventilation-pipe is immersed, according to the variations of the barometer, constant uniformity, as to the density of the atmosphere inside of the building, might be maintained."

The usual mode of ventilating ships is by a canvass bag, called a wind-sail. This is suspended over the principal aperture in the deck, and having an opening in the direction of the wind, a current is propelled downwards, which tends to purify the air. But ventilation is chiefly required in ships during foul weather, when such a process as that of the wind-sail cannot possibly be employed. Mr. Jacob Perkins has proposed, under these circumstances, the following very simple arrangement.

*a* and *b* represent two casks or tanks half filled with water, placed on the opposite sides of the vessel, with a channel *c*, having an open communication with both; *d* and *e* represent two large hoses or pipes, through which the foul



air from below deck escapes into the tank, where there are valves opening inward; *f* and *g* are two pipes furnished with valves opening outwards, serving to discharge the foul air out of the tanks. Now, when the tank *a* is elevated by the ship's motion, the water will run along the pipe *c* into the depressed tank *b*

the rising of the water in which will open the valve of the pipe *g*, and discharge as much air as the water displaces. At the same time the elevated tank *a* is receiving the foul air from below through the hose *d*, the valve in it having been opened by the pressure acting upon the vacuum formed in *a* by the retiring of the water, the external pressure of the atmosphere having shut the valve in the discharge-pipe *f*: now, when the vessel rocks in the opposite direction, as would be represented by a line from *d* to *g*, the charge of foul air in the tank *a*, is discharged by its filling with water in the manner already shown as respects the tank *b*; and thus the operation is continually performed by the oscillation of the vessel. It will, however, be evident that, if the tanks be fixed at right angles to the keel, the ventilation will only be effected by the *rolling* of the ship: but if the tanks be placed diagonally, then the ventilation will be equally effected by the *pitching* also. A very excellent warming and ventilating stove for buildings, particularly adapted to manufactories, by the same ingenious mechanician, is described under the article AIR: which see.

VERDIGRIS; is a crude acetate of copper, employed in the arts as a pigment; see PAINTING. It is usually obtained by moistening the surfaces of copper plates with vinegar, and exposing them to the action of the atmosphere; a bluish green rust, or fine salt, thereby forms upon the surface, which is verdigris. According to Mr. Phillips, the constituents of English and French verdigris are as follow:—

	French.	English.
Acetic acid . . . . .	29.3	29.62
Peroxide of copper . . . . .	43.5	44.25
Water . . . . .	25.2	25.51
Impurity . . . . .	2.0	0.62
	100.0	100.0

The French verdigris has been usually considered the best, but the English of late years has been so much improved in the manufacture, as to be rendered equal to the foreign in the opinion of many. In a manufactory established at Deptford, about twenty years ago, the process which we saw in operation (and which we believe is continued without any essential variation) was as follows: Thin plates of copper, of which there were an immense number, about a foot square each, were folded up in coarse woollen cloths, saturated with pyroligneous acid, (distilled on the premises;) a dozen or more such plates, with the moist cloths between them, forming one pile, were placed to the number of several thousands upon stout wooden racks, built up in an extensive cellar, through which the air had free access; but the underground situation having the effect of preserving the air in a moist state, which we understood was favourable to the process. The plates, after remaining a few days in this state, were taken down, the cloths unfolded, and the green saline matter upon the surfaces of the plates was scraped off by instruments calculated not to remove any portion of the metal; the plates were afterwards folded anew, in the moistened acid cloths, and the process was thus continually repeated, until the copper plates were by imperceptibly slow degrees worn away. The quality of the verdigris thus produced was in great estimation. The manufacture was conducted under a patent-right, which has now expired.

VERDITER. A blue pigment, obtained by adding chalk or whiting to a solution of copper in aquafortis. It is thus prepared. A quantity of whiting is put into a tub, and upon this the solution of copper is poured. The mixture is stirred every day for some hours together, until the liquor loses its colour. The liquor is then to be poured off, and more solution of copper is to be added; and the process thus continued, until the whiting has acquired the requisite depth of tint; when it may be first dried upon large pieces of chalk, and afterwards in the sun's rays. The inferior verditers are deficient of copper.

VERJUICE. An austere vinegar, made from the expressed juice of wild or crab apples. It is used by the wax-chandlers for purifying their wax. Also in French cookery, to give pungency to ragouts, &c.

**VERMICELLI.** A composition of flour, cheese, yolks of eggs, sugar and saffron, reduced to a smooth paste, and formed into long slender pieces like worms, by being forced through little holes, by means of a piston moving in a cylinder.

**VERMILION.** A beautiful scarlet-red pigment. It is usually obtained from mercury, being the red sulphuret of that metal. It is said, by some authors, that the *Chinese* vermilion is a sulphuret of *arsenic*: others, on the contrary, assert that it is prepared from the cinnabar of the East, which being an ore of mercury, already combined with sulphur, renders it an obvious and an easily conducted process. Large quantities of vermilion are manufactured by the Dutch. Their process consists in grinding together 150 pounds of sulphur, and 1000 of quicksilver, and then heating the *Æthiops* mineral thus produced, in a cast-iron pot, two feet and a half in diameter, and one foot deep. If proper precaution is taken, the *Æthiops* does not take fire, but merely clogs together, and requires to be ground. Thirty or forty pots, capable of holding twenty-four ounces of water each, are then filled in readiness with this *Æthiops*.

The sublimary vessels are earthen bolt heads, coated two-thirds of their height with common fire-lute, and hung in the iron rings, at the top of three pot furnaces, built in a stack under a hood or chimney, so that the fire has free access to the coated part; each sublimer has a flat iron plate, which covers the mouth of it occasionally. The fire being lighted in the evening, the sublimers are heated gradually to redness. A pot of *Æthiops* is then flung into each sublimer; the *Æthiops* instantly takes fire, and the flame rises from four to six feet high; when the flame begins to diminish, the sublimer is covered for some time. By degrees, and in the course of thirty-four hours, the whole of the *Æthiops* is put into the sublimers, being 410 pounds into each. The sublimers being thus discharged, the fire is kept up, so that on taking off the covers every quarter or half-hour, to stir the mass with an iron poker, the flame rises about three or four inches above the mouth of the sublimer. The sublimation usually takes thirty-six hours, and when the sublimers are taken out of the furnace, cooled, and broken, 400 pounds of vermilion are obtained from each.

Kirehoff first showed, that by commingling and triturating mercury, sulphur, and potash together, and applying heat, cinnabar might be obtained; but the process was uncertain, and gave variable quantities of vermilion. The following is a process recommended by M. Bruner:—

Mercury . . . . .	300 parts.
Sulphur . . . . .	114
Caustic potash . . . . .	75
Water . . . . .	400 to 450

The mercury and sulphur are first triturated together, from three hours to a whole day, according to the quantities used. When the mixture is homogeneous, the solution of potash is added, the trituration continued, and the mixture heated in an earthen vessel or porcelain, or, if on a large scale, of iron. At first, the stirring must be constant, afterwards, from time to time. The heat should be sustained 113°; it should never pass 122°. The liquid should not be allowed to diminish by evaporation, but be made up. After some hours, the mixture will acquire a reddish brown colour, and then great care is required: the mixture must not pass 113°. If it becomes glutinous, a little water should be added; the mixture of sulphur and mercury should always be in a pulverest form in the liquid. The colour becomes more and more brilliant, and at times increases with astonishing rapidity: when it has attained its highest intensity, the vessel is to be taken off the fire, but still to be retained warm for several hours. The time necessary for the application of heat, appears to be directed as the quantity operated upon. If the proportion above be in grammes, (about 15½ grains each,) the red colour will appear in about eight hours, and the operation be finished in about twelve hours.

The cinnabar is then to be washed, and the small quantity of metallic mercury that may be present, separated; from 328 to 330 parts of vermilion will

be obtained, of a colour, equalling that of the native cinnabar, and far surpassing that of cinnabar obtained by sublimation. The mercury and the potash should be quite pure.

**VICE.** An instrument consisting chiefly of a pair of stout jaws or chaps, which are brought together by the aid of a screw, to compress, or hold fast any substance placed between them. Vices are of almost indispensable utility to smiths, engineers, and the generality of mechanics, to the peculiar wants of certain classes of whom, they are sometimes variously modified: but the vices in general use, are those termed smiths' vices, and these are of several kinds; namely, the standard vice, the bench vice, and the hand vice. The first-mentioned has a long standard bar reaching to the ground, by which it may be stapled to the side of an upright post; and likewise a pair of flattened horns, by which it may be nailed to the top of the post, or to a work-bench. They are made of various sizes, and weigh from 15 to 150 pounds each, according as they may be required for heavy or light work. The second sort, bench-vices, are of a smaller class; they have no standard bar, and are contrived so as to be clamped firmly to the bench, by means of a screw and wrench, and the horns or claws above. Of this kind, a very superior quality used by watch-makers, clock-makers, and other delicate mechanists, is made by the Lancashire tool-smiths, whose workmanship surpasses all others. The third kind, hand-vices; these, though of various sizes, and modified in a thousand ways, are all so small as to be held in one hand, that the article they gripe may be worked upon by the other; the jaws are drawn together or asunder by a small thumb screw.

**VINEFICATEUR.** An apparatus for collecting the alcoholic vapours that usually escape from fluids during the process of vinous fermentation. It is a conical vessel or cap, covering a hole in the top of the fermenting tun, which is in other respects closed air-tight. The conical vessel is surrounded by a reservoir of cold water, so that the spirituous vapours, rising from the working tun, may be condensed when they enter the cone, and running down its sides, be conducted by a pipe back into the tun. The cap is provided with a tube, to carry off the gaseous portion of the vapour which has not been condensed.

**VINEGAR.** Acetic acid in a dilute state, combined with mucilage, and sometimes accompanied with flavouring ingredients. Though frequently resulting from spontaneous fermentation, this useful acid is usually obtained by the manufacturing processes of brewing and fermentation. There are four principal kinds; namely, wine vinegar, malt vinegar, sugar vinegar, and wood vinegar. The process of preparing the last-mentioned, has been already described under the article **Acid**, in the first volume; our attention is therefore here restricted to the three former.

*Wine Vinegar.* In Paris, the wine destined for making vinegar, is usually mixed in a large tun, with a quantity of wine lees; the whole is then transferred into cloth sacks, placed within a large vat, and the liquid portion of the matter is extruded through the sacks by superincumbent pressure. What passes through is run into large casks, set upright, having a small hole in their tops. In these vessels, it is exposed to the heat of the sun in summer, or to that of a stove in winter. Fermentation takes place in a few days. If the heat should then rise too high, it is lowered by cool air, and the addition of fresh wine. In the skilful regulation of the fermentative temperature, consists the art of making good wine vinegar. In summer, the fermentative process is usually completed in a fortnight; in winter, about double the time is requisite; after which, it is run off into casks, containing some chips of birch-wood, where it is allowed to remain, until it has become clear and bright, which usually takes a fortnight more. The vinegar is then put into close casks, and is ready for the market.

At Orleans, the manufacturers prefer wine of a year old, for making vinegar; but, if the wine has lost its extractive matter, by age or otherwise, it does not so readily undergo acetification, which is, however, brought about by the addition of bunches of grapes, slips of vine, or green woods, abounding with extractive matter. Almost all the vinegar of the north of France being prepared at Orleans, the manufacture of that place has acquired such celebrity, as to render the process employed there worthy of particular attention.



The Orleans casks contain nearly 400 pints of wine. Those which have already been used, are preferred. They are placed in three rows, one above another, and in their tops, have an aperture of two inches diameter, kept always open. The wine for acetification is kept in adjoining casks, containing beech shavings, to which the lees adhere. The wine thus clarified, is drawn off to make vinegar. One hundred pints of good vinegar, boiling hot, are first poured into each cask, and there left for eight days. Ten pints of wine are mixed in, every eight days, until the casks are full. The vinegar is allowed to remain in this state fifteen days, before it is exposed for sale. The used casks, called *mothers*, are never emptied more than half, but are successively filled again, to acetify new portions of wine. In order to judge if the *mother* works, the vinegar-makers plunge a spatula into the liquid; and, according to the quantity of froth which the spatula shows, they add more or less wine. In summer, the atmospheric heat is sufficient. In winter, stoves heated to about 76° Fahr. maintain the requisite temperature in the manufactory.

In some country districts, the people keep, in a place where the temperature is mild and equable, a *vinegar cask*, into which they pour such wine as they wish to acetify; and it is always preserved full, by replacing the vinegar drawn off, by new wine. To establish this household manufacture, it is only necessary to buy at first a small cask of good wine. The following mode of preparing vinegar, which was described by Boerhaave, more than a century ago, is still in practice in various parts of France, and elsewhere:—

“Take two large casks or hogsheds, and in each of these, at the distance of a foot from the bottom, form a false-bottom of wicker-work; set the vessel upright, and on the grate place a moderately close layer of green twigs, or fresh cuttings of the vine. Then fill up the vessel with the foot-stalks of the grapes, commonly called the rape, to the top of the vessels, which must be left quite open. Having thus prepared the two vessels, pour into them the wine to be converted into vinegar, so as to fill one entirely, and the other only half-way up. Leave them thus for twenty-four hours, and then fill up the half-filled vessel with liquor, from that which is quite full, and which will now, in its turn, be left only half full. Twenty-four hours afterwards, repeat the same operation, and thus go on, keeping the vessels alternately full and half full, during twenty-four hours, till the vinegar be made. On the second or third day, there will arise in the half-filled vessel, a fermentative motion, accompanied with sensible heat, which will gradually increase from day to day. On the contrary, the fermenting motion is almost imperceptible in the full vessel; and, as the two vessels are alternately full and half full, the fermentation is, by this means, in some measure, interrupted, and is only renewed every other day in each vessel. When this motion appears to have entirely ceased, even in the half-filled vessel, it is a sign that the fermentation is finished; and therefore, the vinegar is then to be put into casks, close-stopped, and kept in a cool place. A greater or less degree of warmth accelerates, or checks this, as well as the spirituous fermentation. In France, it is usually finished in fifteen days, during the summer; but if the heat of the air be very great, and exceed 25° of Reaumur's thermometer, (88½° Fahr.) the half-filled vessel must be filled up every twelve hours; because, if the fermentation be not so checked in that time, it will become violent, and the liquor will be so heated, that many of the spirituous parts, on which the strength of the vinegar depends, will be dissipated, so that nothing will remain after the fermentation, but a vapid liquor, sour indeed, but effete. The better to prevent the dissipation of the spirituous parts, it is a proper and usual precaution to close the mouth of the half-filled vessel, in which the liquor ferments, with a cover made of oak wood. As to the full vessel, it is always left open, that the air may act freely on the liquor it contains; for it is not liable to the same inconvenience, because it ferments but very slowly.”

In observing the phenomena of this fermentation, M. Fourcroy remarks, (*Elements of Natural History and Chemistry*, London, 1790,) we perceive a great deal of boiling and hissing. The liquor becomes hot and turbid; a great many bubbles and filaments appear to run through it in all directions: there exhales from it a lively acid smell, which is no way dangerous: it absorbs a

great deal of air. By degrees, these phenomena disappear; the heat falls, the emotion ceases, and the liquor becomes clear. It deposits a glareous sediment in reddish flakes, which stick to the sides of the casks. It appears, from a sufficient number of experiments, that the smaller the quantity of the wine, and the more it is exposed to the contact of air, so much the more readily does it pass into the state of vinegar. Care must be taken to draw off the vinegar clear, when it is thus prepared, in order to separate the lye, which, were this precaution neglected, would cause it to pass into the state of putrid fermentation. Vinegar does not, like wine, deposit tartar by rest: that salt was dissolved, and combined with the alcohol and water, during the fermentation. It is even probable, that the presence of the salt has a principal influence in calling forth the properties of vinegar from a latent state.

*Malt Vinegar*, which is chiefly used, and extensively manufactured in this country for foreign as well as home consumption, is made by macerating malt (in some instances mixed with a proportion of unmalted barley,) in hot water. From each boll of the grain is extracted one hundred gallons of wort, and when the temperature is reduced to about 75° of Fahr. four gallons of beer yeast are added to each hundred gallons. The liquor is next racked off into a series of upright vats, arranged in a stove-room, kept heated to a temperature of nearly 90° Fahr. The vats are provided with perforated false bottoms, on which is strewed a quantity of *rape*, the refuse from the makers of British wine, or some low priced raisins. Every twenty-four hours, or oftener, should the liquor grow too warm, the principal portion of the liquor of each alternate vat is pumped out, and discharged into the adjoining one, two vats being usually worked together, in the manner already described, until the active fermentation is completed. After this, the liquor is drawn off clear into large casks or pipes, which are laid on their sides, exposed to the air, the bung-holes being only loosely covered, to exclude accidental impurities.

**VINERY.** A garden erection, usually consisting of a wall 12 or 14 feet high, extending in an easterly and westerly direction, covered with a roof and glass lights, furnished with a stove and flues, and every convenience for the protection and cultivation of vines.

**VIOLIN**, or fiddle; a well-known stringed instrument of brilliant tone, the vibrations in which are produced by means of a bow.

**VIOLONCELLO**, or bass viol; a similar instrument in construction to the violin, but of a larger size, and having a more powerful effect. An improvement in the violoncello was lately made by Mr. S. A. Forster, of Frith Street, Soho, London, for which that gentleman received an honorary medal from the Society of Arts. The tail-piece of a violoncello is a thin board, usually of ebony, fixed at the end of the instrument, opposite to the pegs, and to which the ends of the strings are tied, or otherwise fastened. Mr. Forster's invention consists, first, in making three longitudinal cuts in the tail-piece, dividing it into four bars, united only at the lower end, sufficiently separated at the other to prevent their touching while in a state of vibration; and attaching the strings one to each of the bars. In each bar are three holes, and the string is to be fastened to whichever of them on trial shall be found to give the most perfect tone. Secondly, the material of the tail-piece, instead of being wood, as usual, is of soft hammered brass; this alloy being found to give freer vibrations than copper, and to be preferable to iron or steel, on account of the metallic quantity of tone which attends the use of these substances. By the above arrangement, each string being attached to its own bar, the string and bar form a continuous and distinct line, and therefore the vibrations of the different notes interfere less with each other. When the strings are tied to one common tail-piece, the breaking of one puts all the others out of tune; but in Mr. Forster's invention, as each string has its own bar or tail-piece, the breaking of one affects the others in a very slight degree.

**VITRIOLS.** A class of salts formed by earthy or metallic combinations with the vitriolic or sulphuric acid.

**VOLUTE.** A spiral scroll, used in the Ionic and Composite capitals of columns, whereof it makes the principal characteristic and ornament.

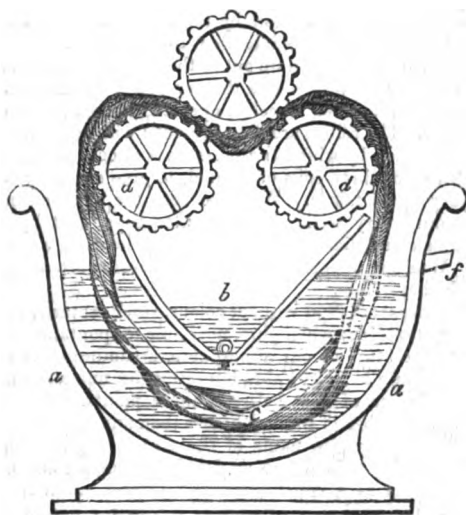
## W.

**WAFERS.** Small discs of dried paste, used for sealing letters. The mode of making them is as follows:—Take fine wheat flour, mix it with white of eggs and isinglass into a very smooth paste, and spread the same over tin plates evenly, and dry them in an oven, placing several of the plates one over the other to communicate a glossy surface to the wafers. When dry, the sheets of paste thus formed are laid up in a pile, about an inch or more in depth, and cut out into circular pieces by a hollow punch, which allows the wafers to pass up its tubular cavity and discharge themselves sideways as the cutting proceeds, which is effected with great rapidity. The variety of colours that are ordinarily communicated to wafers, is given to them in the paste, by the usual pigments in the dry powdered state, or previously dissolved in the water employed. As the ornamental substitute for sealing-wax and wafers taken from gems, seals, or Tassie's copies thereof, which was recently much in fashion, possesses some utility as a very convenient cement, we shall here add the mode of preparing it. A solution of Salisbury glue, in water previously tinged red, purple, yellow, &c., by Brazil-wood, log-wood, turmeric, &c. must be prepared of a proper consistence. The hollows of the gem, &c. must then be moistened with a little weak gum-water, in which any white or coloured opaque powder is mixed; or with the gum-water alone, and the colour in powder sifted over it; all the colour must then be wiped off the plain parts, leaving it only in the hollows. As much of the melted glue must then be poured upon the gem as can lie upon it, and be suffered to dry in a gentle heat; when it will shrink considerably, so as to become not thicker than an ordinary sheet of writing paper; it readily quits the gem, presenting a beautiful cast of it. To use it, the folded note, letter, &c. should be wetted on the part where the glue-wafer is to be applied, and the back of the wafer be placed on the wet part, when it will soon adhere, by its glutinous property, and thus form an elegant closure to the letter. It should be remarked, that this is merely the revival, and application to a different purpose, of a well-known process, formerly much used for taking casts from medals, coins, &c.; viz. by making a solution of isinglass in proof-spirit, straining it clear, and pouring it over the surface of the medal, &c. The isinglass shrinks in drying, and will readily quit the surface of the medal; it may then either remain in its transparent state, or, by breathing upon it, a coat of leaf gold or silver may be applied to it, and thus give it the appearance of metal.

The French isinglass wafers are made in France, in the following manner. The isinglass being dissolved in water to the proper consistence, is poured out upon plates of glass provided with borders, and laid upon a level table; to prevent the glue from sticking to the plates, a little ox-gall, or other fit material should be rubbed over them. Previous to the isinglass becoming quite dry, they are to be cut through along the borders. The leaves are then removed, and cut out with hollow punches, as other wafers are. The various colours are communicated to them by pigments while in the fluid state. They are sometimes flavoured with essential oils and aromatics, as well as fruits, to give them an agreeable taste. For sealing letters, these wafers afford more security than the ordinary paste kind.

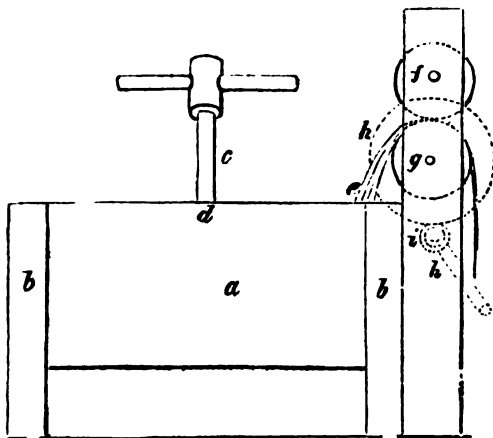
**WASHING-MACHINE,** in the common acceptation of the term, is an apparatus for cleansing linen, cloth, and various fabrics; there is a great diversity of them, but one or two that we shall describe will, in a great measure, afford an idea of the generality. In the annexed figure is given a section of Mr. Flint's Patent Machine for cleansing woollen cloths from dirt, and their excess of colouring matter, after having been dyed. *a a* is the section of a water trough, filled with water up to the pipe *f*, by which it is supplied; *b* is an inner vessel for receiving the dirt and the colouring matter, as it falls from the cloth between the two cylinders *d d*, when pressed by the action of the upper cylinder. These cylinders are made of wood, with reeds or flutes along their peripheries, and revolve upon their axes, in bearings fixed in the sides of the trough, which cannot be shown in this view. The cloth *c* is put over the two lower cylinders (as a round towel) in an endless coil; the

cylinders are put in motion, by gear or by hands from any adequate first mover. By this arrangement the cloth is gently pressed between the flutes or ribs of the revolving cylinders, passing through the soapy water below in easy folds, while



the extraneous colouring matter and dirt falls and is collected in the inner vessel, preserving the water in the outer vessel from a great proportion of the foulness which it would otherwise acquire.

A few years ago, Mr. Bullman, of Leeds, whose patent mangle we have described, took out a patent also for a washing and wringing machine, combined



in one apparatus; the principal arrangements of which will be understood by reference to the above diagram. Mr. Bullman justly states that the ordinary process of wringing is peculiarly destructive of linen apparel, especially such as

are of a delicate texture; and, to obviate this defect, he causes the linen to be passed from the washing machine between rollers which squeeze by simple pressure the water out of them, so as to make them nearly dry.

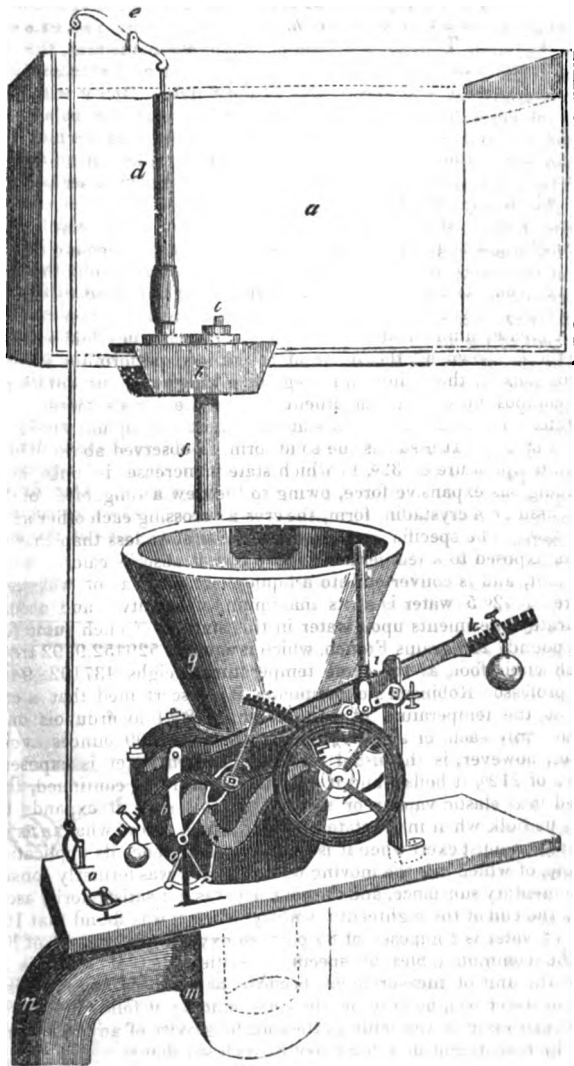
*a* is the vessel holding the clothes and water, standing upon stout legs *b b*: it has a circularly curved bottom, to accommodate the action of an oscillating beating frame which is put in motion by the cross handle *c*, and turns upon a fulcrum at *d*. The lines at *e* are intended to represent some of the clothes, supposed to be washed, being taken up out of the vessel by means of the rollers *f, g*, between which they are compressed as they emerge from the vessel. The axis of the roller *g* carries a toothed wheel *h*, operated upon by a small pinion *i*, by turning the winch *k*. The rollers are duly provided with apparatus to adjust their distance from each other, by which the pressure is of course regulated; and they are covered with two or three coils of flannel, to give elasticity to the pressure, and prevent injury to the fabric. We have seen the machine in action, and it seems to do its duty very well. The patentee says, that by the use of the wringing apparatus alone, linen will last twice as long as when wrung in the usual manner. Washing machines for other processes are described under the subjects to which they relate.

**WATER.** A transparent fluid without colour, smell, or taste, and compressible only in a very slight degree; when pure, not liable to spontaneous change; liquid at the common temperature of our atmosphere, assuming a solid form at 32° Fahr. and a gaseous state at 212° Fahr., but returning unaltered to its liquid state on resuming any degree of heat between these points. Water is capable of dissolving a greater number of natural bodies than any other fluid whatever, and especially those known by the name of the saline; performing the most important functions in the animal and vegetable kingdoms, and entering largely into their compositions as a constituent part; water exists therefore in three different states: in the solid state or state of ice, in the liquid, and in the state of vapour or steam. It assumes the solid form, as observed above, when cooled down to the temperature of 32°, in which state it increases in bulk, and hence exerts a prodigious expansive force, owing to the new arrangement of its particles, which assume a crystalline form, the crystals crossing each other at an angle of 60° or 120°. The specific gravity of ice is therefore less than that of water. When ice is exposed to a temperature above 32°, it absorbs caloric, which then becomes latent, and is converted into a liquid state, or that of water. At the temperature of 42° 5' water is at its maximum of density; and according to some accurate experiments upon water in this state, a French cubic foot of it weighs 70 pounds 223 grains French, which is equal to 529452.9492 troy grains. An English cubic foot, at the same temperature, weighs 437102.4946 grains troy. By professor Robinson's experiments, it is ascertained that a cubic foot of water, at the temperature of 55°, weighs 998.74 avoirdupois ounces, of 437.5 grains troy each, or about 1½ ounce less than 1000 ounces avoirdupois, which latter, however, is the usual estimate. When water is exposed to the temperature of 212°, it boils; and if this temperature be continued, the whole is converted into elastic vapour or steam. In this state it expands to about 1800 times its bulk when in the state of water, which shows what an astonishing expansive force it must exert when it is confined; and hence its application to the steam engine, of which it is the moving power. Water was formerly considered as a simple elementary substance, and the contrary was not satisfactorily ascertained till towards the end of the eighteenth century, when it was found that 100 parts, by weight, of water is composed of 85 parts of oxygen gas, and 15 of hydrogen gas. In the common tables of specific gravities, that of water is assumed as 1.000, or the unit of measurement, because, as has been already observed, a cubic foot of water weighs very nearly 1000 ounces; it follows, therefore, that the number expressed in the table as the specific gravity of any other substance, gives also the real weight of a cubic foot of such substance.

**WATER, boring for.** See BORING THE EARTH.

**WATER-CLOSET.** It was not until that important little contrivance, called the water lute or air-trap was invented, (which we have described under the last-mentioned designation) that private dwellings could be even partially secured

against the annoyance of unpleasant effluvia; but however excellent may be the principle of this invention, by neglect or gross mismanagement, its application was rendered a greater evil than a benefit, until the late ingenious Mr Bramah devised the apparatus, now termed a water-closet. Succeeding ingenious men materially improved it, and have given to it a variety of forms and modifications. Out of the many presented to our notice, we have selected three for description in this place, which appear to us to be deserving of public



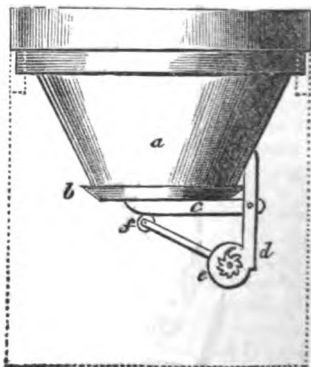
patronage. The first we shall mention is the patent self-acting water-closet, invented by Mr. J. Downes, of High Holborn. It is put into operation by the

removal of the person's weight from the seat, so as to be entirely self-acting, and independent of the usual attention of letting on the water.

*a* in the foregoing engraving represents the water cistern, placed as usual at a sufficient elevation above the closet to give the water an impetus; *b* is the service box, for regulating the supply; water enters it by the valve *e*, and air by the pipe *d*; *e* is a small lever by which a communication between the valve *e* and the machinery is effected, as may be seen by the wires extending from one end of it down the pipe *d*, and from the other to the cranks *o o o*; *f* is the pipe by which the water is supplied to the basin *g*; *i* is a pushing rod attached to the seat, which is hinged at the back to a projection from the axis of a long lever *k*, so that when a person's weight is placed upon the seat, the left hand end of the lever is pushed down till the pendant link at *b* catches the hooked end of a one-armed lever as represented in the figure. Now it will be observed that when the person's weight is removed from the seat, the balance weight *t* will descend and raise the link *b*, and with it the hooked lever which is attached by a looped connecting link, to a toothed sector movable on an axis which is connected to, and turns back the soil pan, when the water is let on by the elevation of the lever. When the upper lever rises to its greatest elevation, the pendant link *b* slips off the hooked end of the lower lever, which then, by a counterpoise attached to the toothed sector, is brought back to its stationary position, at the same time shutting the valve *e*, and returning the soil pan to take in the bottom of the basin. The quantity of water contained in the service box, when its valve is shut, descends into the basin and fills up the soil pan and the lower part of the basin, thus preventing any escape of effluvia from the soil pipes. The use of the fly wheel, which is put in motion by the toothed sector acting on a small pinion fixed on its axis, is to prevent by its inertia the water from being too suddenly shut off when the lower lever is liberated.

This closet, though somewhat complicated in appearance, is really simple in its action, and, as manufactured by the patentee, not very liable to derangement.

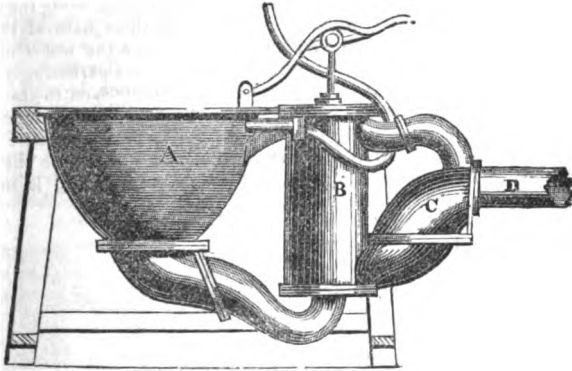
Beacham's patent water-closet, is of the portable kind. It represents, in its external appearance, an ornamental piece of cabinet-work. Our drawing and description has of course only reference to the interior. The construction is seen by the annexed diagram. *a* is the basin, *b* the trap or valve at the bottom, *c* a piece of brass affixed to the bottom of the valve, acting as a lever for opening or shutting the same, its fulcrum being on a fixed axis in two upright brass stems, one of which is shown at *d*. The latter are affixed to the metallic casing which encloses the basin, and thus forms a supporting frame-work for this part of the apparatus. The lower ends of the stem *d* form two circular checks *e*, for enclosing a convoluted spring of a cylindrical form, like the usual door spring; but instead of steel, it is made of tough hammer-hardened brass, which possesses, when coiled up, considerable elasticity, and is not destroyed or injured like steel by rapid corrosion. To the spring is attached a stem, carrying an anti-friction roller, which presses against *c* with the requisite force to keep the valve *b* shut; this force may at any time be regulated in a minute, by means of a screw on the opposite side of the barrel or spring; if turned with a screw-driver in one direction, the force of the spring is increased, and if in the reverse direction, it is relaxed; and it is fixed to the required degree by the pall falling into the teeth of the ratchet-wheel, shown in the centre of *e*. The method of working the valve by the action of this spring, is the essential and valuable part of the invention, and it is that on which the claim of patent-right depends. The little roller, it will be observed,



does not act upon a horizontal plain surface, nor against an inclined plane, but it runs upon the curved or convex surface at the end of the piece *b*; the effect of which is, that when the trap or valve is opened by the weight of the contents of the basin, or by water from the pump, the force of the spring gently relaxes, instead of increasing, permitting it to open wide, and be thoroughly cleaned; and the valve, as it returns, being operated upon by the increasing force of the spring, is thereby shut up very closely. This mode of regulating the pressure is ingenious, and produces that uniformity and certainty of effect so much desired; without which, indeed, a machine of the kind is a nuisance instead of a convenience. The dotted lines show the manner in which the apparatus is dropped into a pail. The double rim of the latter is made to contain a little water, forming a little canal all round, and the projecting rim of the former being immersed in it, an air-tight joint is thus produced, which prevents the escape of effluvia. The pail, &c. is enclosed in mahogany or other cases, wrought so as to represent various articles of the furniture of a room in the usual way.

Another very ingenious contrivance adapted to be used in a house, but especially calculated for ship-board, was invented by Mr. Downton, Blackwall; the soil being forced out of it by means of an air-pump, so that its perfect operation may be ensured in any situation, above as well as below the surface of the water.

A is the basin; B the air-pump, on the raising of the piston of which by means of the lever shown, the soil is drawn into it from A through the bent tube; on depressing the piston in B, the valve at the bottom of it closes, and a valve at C



opens, through which the soil is driven, and along the pipe D to the required distance, the soil being prevented from returning by the closing of the valve at C. In the upper part of the basin there is a small pipe leading into the upper part of the cylinder, where a valve opens inwards; consequently, in depressing the piston, the foul air is drawn from the basin into the cylinder, and on raising the piston, the foul air is forced out of the cylinder by the large bent tube shown, into the discharge-pipe D. To the pump lever the usual cranks are connected for turning on and off the clean water, supplied by the small pipe which is shown bent round the cylinder.

**WATER-COLOURS.** Pigments in which water is employed as the vehicle for painting with, in contradistinction to oil-colours, wherein oil is the vehicle - the colouring matters are the same in both cases. For water-colour painting, the pigments are ground extremely fine, and made up into elegant little cakes, with mucilage or gelatine, and may be had at the principal colour-shops in a state of great purity and beauty. See **PAINTING**.

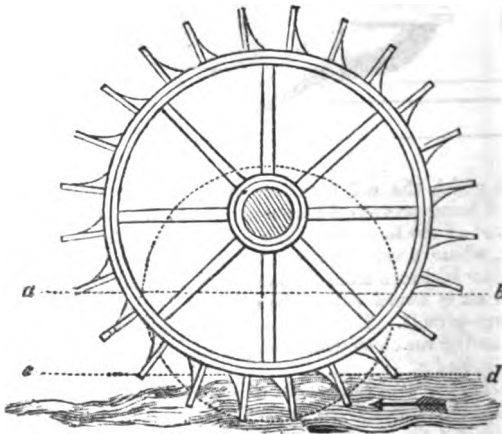
**WATER-MILL,** is a general term applied to all mills moved by the force or weight of water; many of the mills or machinery described in the course of this work would be popularly called by the indefinite term, water-mills. Now, the



modes of communicating the impulse of water to the driving of machinery are various; some of these are described under the head **HYDRAULIC-MACHINES**; and amongst them one of great excellence, denominated the "**Statical Hydraulic Engine**;" and all that we have to add to the subject in this part of the work will properly fall under the designation of **WATER-WHEELS**, given in the sub-joined article: as it is by the application of water-wheels that mills become water-mills.

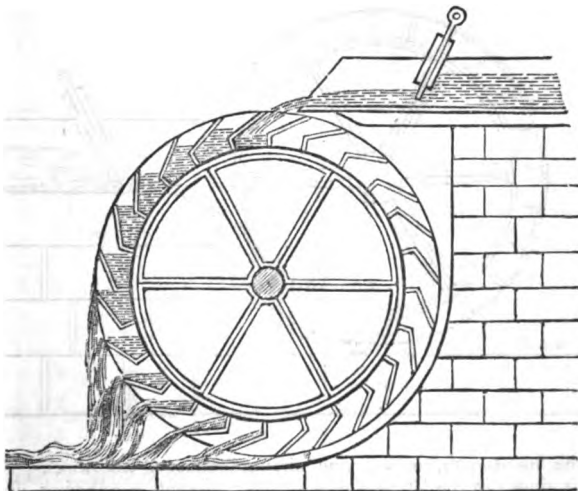
**WATER-WHEEL**, in the common acceptation of the term, is an instrument by which the moving force of water is employed to communicate motion to machinery; there is, however, another class of water-wheels, commonly called paddles, in which the water is employed as a stationary resisting force. The last mentioned class is described under the head of **STEAM-VESSELS**, in which it forms the most conspicuous feature. Under the present section we therefore confine our notice to the first-mentioned class of water-wheels, of which there are three distinct kinds, namely, the *undershot*, the *overshot*, and the *breast-wheel*. (There is usually described in books upon the subject, a fourth kind, called the *horizontal* wheel; but it is so disadvantageous an arrangement, compared to the three first mentioned kinds, that we shall exclude it from our description.

The *undershot water-wheel* is that commonly used in rivers and streams, and is by far the most ancient kind; it requires no other fall or inclination of the stream than may be sufficient to produce a rapid progressive motion on it; and as it acts chiefly by the momentum of the water,—its positive weight being scarcely called into action,—it is only fit to be used where there is a profusion of water always in motion. This wheel has, however, the advantage of being the cheapest of all water-wheels, and is more applicable to rivers in their natural state than any other form. It likewise works equally well whether the water acts upon the one or the other side of its float-boards; which renders it particularly applicable to tide rivers, where the current changes from one direction to the opposite one at ebb and flood. There are, however, some practical disadvantages attending this form of wheel, when made of small diameter, or the increase of water causes a large wheel to be immersed too deeply. In either case the effect is similar. Let us first suppose that the wheel delineated beneath, is immersed



in water up to the dotted line *a b*; the float-board *b* would press downward upon the water, while that at *a*, on the opposite side, would press the water upward; now these two resisting forces combined, together with the unavoidable friction of the machinery, would almost neutralize the whole force that might be derived from the current, if the water line was above the dotted line *c d*. Now in the other case of a wheel of small diameter, such as

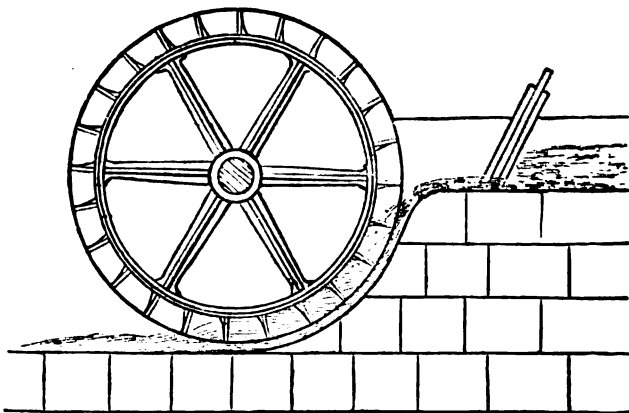
we will suppose the dotted circle to represent, and the floats fixed radially around it, in the same manner and at the same distances apart as in the large wheel, it will be evident that a less number of floats will be submerged or exposed to the action of the current; consequently, they will assume the same unfavourable position as has been described, by the deep immersion of the large wheel; and that, were the small wheel immersed up to the line *ab*, which is even with its axis, it would not move at all, as the force or weight of water on each side would be exactly balanced. Persons but little skilled in the principles of mechanics, have attempted to gain an advantage, by placing the float-boards tangentially to the circle, so that the floats shall *leave* the water edgeways, and not lift it up at all, as in the one we have figured; omitting to notice, or give due weight to the fact, that the floats which are entering the water on the opposite side of such a wheel are, in consequence, posited so as to strike against the water with their broad sides, which thereby counterbalance the advantage gained on the other; and we submit to the consideration of those mechanics who prefer the tangential to the radial position of the floats, that it is less destructive to the wheel and all the mechanism to which it may be connected, to receive two equal concussions of small force on opposite resisting sides of the wheel, than one concussion of double the force upon only one side of the wheel; the direct tendency, it appears to us, is to break the arms of the wheel, close to the axis. Whenever the weight and motion of water can be made use of as well as its momentum, much greater effects can be produced than the last described machine is capable of, and with a much less lavish expenditure of the fluid, for then its utmost powers of action are brought into play at once; and accordingly, those water-wheels that are distinguished by the name of breast-wheels, and overshot wheels, will produce much greater power, with a much less supply of water, than the undershot wheel already described. Both these wheels, however, require a considerable fall in the stream upon which they are placed, and consequently destroy it for the purposes of navigation, unless that ingenious hydraulic contrivance, the CANAL LOCK, be resorted to, by means of which barges or vessels of any magnitude may be transported from one level to another without difficulty, and with very little loss of time. The *over-shot* water-wheel, which of all others



gives the greatest power with the least expense of water, requires a fall in the stream equal to rather more than its own diameter; therefore it is customary to give this description of wheel a greater length in proportion to its height than is

given to any other,—by which an equality of power is obtained. In the construction of the over-shot wheel a hollow cylinder or drum that is impervious to water, is first prepared, and hung upon a proper central axis. A number of narrow troughs or cells, generally formed of thin plates of metal, extending from one end of the drum to the other, are next fixed round the outside of the wheel, so as to give a transverse section through the middle of the wheel the appearance shown in the preceding figure. The water is conducted by a level trough of the same width as the wheel, over its top, and is thence discharged into the buckets or cells placed round the wheel to receive it; from the particular form of these buckets, they retain the water thus thrown into them, until by their motion they descend towards the point when, their mouths being turned downwards, they discharge their contents into the tail-stream, where the water runs to waste. The buckets on the opposite side of the wheel, ascend with their mouths empty, until they arrive under the end of the water-trough, to be refilled, where there is a pen-stock or sluice, for regulating the quantity of water and preventing waste; since, if the water was permitted to flow too rapidly, it would splash out of the buckets instead of filling them, and would run down over the surface of the wheel, without producing its proper effect. To prevent this, the water is seldom permitted to run upon the wheel in a stream of more than from half an inch to an inch in thickness, and when well regulated there is scarcely a drop of water ineffectually used. The overshot wheel acts, therefore, by the gravity or weight of the water contained in the buckets, for nearly one-third of its circumference; and from the experiments of Mr. Smeaton, which were made with great accuracy, it appears that the dimensions, quantity of water, and height of fall being the same, the over-shot wheel will produce double the effect of the under-shot.

The breast-wheel is by far the most common, and may be considered as a mean between the two varieties before mentioned. In this, the water, instead of passing over the top of the wheel, or entirely beneath it, is delivered about half-way up it, or rather below the level of the axis; and the race or brickwork upon which the water descends is built in a circular form, having the same common centre with the wheel itself, so as to make it parallel to the exterior



edges of the float-boards, or extreme circumference of the wheel. This construction is shown in the above figure, which represents a side-view of a wheel, formed with float-boards in the same manner as the undershot wheel; but instead of the water acting upon its lower part, it is introduced upon it midway, by the sluice or pen-stock, which, by rising or falling, permits a greater or less quantity of water to act on the wheel; and as the float-boards are made to

fit as accurately as possible, without contact, into the circular hollow of the brick-work, no water can escape past the wheel, without producing its proportionate effect.

Mr. Smeaton states, that all wheels by which the water is prevented from descending, unless the wheel moves therewith, are to be considered of the nature of over-shot wheels, having power in proportion to the perpendicular height from which the water descends; while all those that receive the impulse or shock of the water, whether in an horizontal, perpendicular, or oblique direction, are to be considered as under-shots. The breast-wheel is nearly allied to the over-shot; for notwithstanding it has only float-boards, instead of buckets, yet as the mill-course is made concentric to the outside of the wheel, and is not only there, but at the two sides, made as close as convenient, so as to prevent the escape of water as effectually as possible, the spaces between one float-board and another, become buckets for the time being, and retain the water, and thus the breast-wheel is not only impelled by the weight of water, but by its impetus or momentum also; for the water is so confined, as to be incapable of splashing or being lost, and consequently, its moving force may be exerted to great advantage. Notwithstanding this apparent superiority, still the breast-wheel is, in effect, vastly inferior to the over-shot wheel, not only on account of the smaller height at which the water is supplied, but from the waste with which it must always be attended, even under circumstances of the most perfect workmanship. When well-constructed, and closely built in, its effect, according to Mr. Smeaton, should be the same as an under-shot wheel, whose head of water is equal to the difference of level between the surface of the stream and the point where it strikes the wheel, added to the effect of an over-shot wheel, whose height is equal to the distance from the striking point, to the tail-water of the mill, or that which runs to waste. This is, however, on the presumption that the wheel receives the impulse of the water at right angles to its radii, and that every thing is constructed to the best advantage. In practice, it is found that the breast-wheel consumes about double the quantity of water that the over-shot wheel requires, to do the same quantity of work, when all things are alike,—that is to say, the diameter and breadth of the wheel, number of float-boards, &c.,—though from theory and calculation, it should rather do more; for Lambert, and others who have written on this subject, attempt to demonstrate, that the power of the over-shot, to that of the breast-wheel, is as thirteen to five; but this is upon a supposition, that no water escapes ineffectually, which is utterly impossible in practice. In order to permit any of the above wheels to work with freedom, and to the greatest advantage, it is absolutely necessary that the tail-water, as it is called, or that which is discharged from the bottom of the wheel, after it has produced its effect, should have an uninterrupted passage to run away; for whenever this is not the case, it accumulates, and forms a resistance to the float-boards,—and consequently, abstracts considerably from the velocity and power of the wheel, sometimes indeed to so great an extent, as to prevent its working altogether. One of the simplest and most effectual means of removing this inconvenience, (says the author of the *Treatise on Hydraulics*, in the "*Library of Useful Knowledge*," for whose observations we are largely indebted in the present article,) is by an expedient, not much known or practised, and which consists of forming two drains or tunnels through the brickwork or masonry, at each side of the water-wheel, whatever may be its construction, so as to permit a portion of the upper water to flow down into the tail or lower stream immediately in front of the wheel. The water thus brought down with great impetuosity, drives the tail-water before it, in such a manner as to form a basin or hollow place, in which the wheel can work free from interruption, even if the natural state of the water were such as might produce a tailing of from twelve to eighteen inches, without this assistance. And since the tailing of mill-streams only occurs in the winter seasons, or at times when there is a profusion of water, so the quantity that is thus thrown away without operating upon the wheel, can be spared without inconvenience. Each of the drains or tunnels is furnished with a sluice-gate or pen-stock at its upper end, by which the quantity and impetus of the water can be regulated at pleasure, or the whole be shut off, whenever water happens to be scarce.

The three varieties of water-wheels already noticed, are the only ones generally admitted into practice, and they do not admit of much improvement, since their principles must always remain the same. The over-shot wheel has, perhaps, been brought nearer to perfection than any of the others, by the contrivance of Peter Nouaille, Esq. who, in a mill that he has near Seven Oaks, in Kent, has caused the water to revert back again from the top of the wheel, instead of passing over it; and in this way a much greater portion of the circumference of the wheel is brought into action than is generally the case. Other improvements or variations in the form and construction of water-wheels, have been contrived by Mr. Besant, Mr. Smart, Mr. Perkins, and others, which will be found described in the *Transactions of the Society for the Encouragement of Arts, Manufactures, and Commerce*; the object of them principally being to obtain as much force as possible from the water, by arranging the forms of the buckets or float-boards, in such manner that they may receive the greatest impulse or retain the greatest quantity of water, which is of great importance, particularly in the construction of under-shot wheels, which act by the impulse of the water alone. The over-shot wheel depends entirely on the weight of the water delivered into its buckets, which ought, therefore, to be as capacious as they can conveniently be made,—not only that they may contain as much water as possible, but allow ample room for the discharge of the air that will be thrown into them with the water, as well as for the delivery of that water, when done with. From the nature of a water-wheel, it will be evident, that if it had no work to perform, or resistance to overcome, it would move with the same velocity as the stream that drives it; while, on the contrary, if it was loaded with a quantity of resistance, equal to the power of the stream, it could not move at all: hence, every degree of resistance between these extremes, will produce its proportionate retardation of the wheel; and from accurate experiments which have been tried, it has been determined, that an under-shot wheel does its maximum quantity of work, when its circumference moves with between one-half and one-third of the velocity of the stream that drives it. The over-shot wheel cannot be so influenced by the velocity of the water, because it requires all its buckets or cells to be filled in succession; and Mr. Smeaton has determined, that the best velocity to effect the above purpose, is three feet in a second. Having, therefore, previously determined the quantity of water which the stream will deliver in a given time, it becomes a matter of easy calculation to determine the length and capacity of the buckets which shall be capable of carrying off the water at that velocity. Thus, for example, if the stream is found to deliver ninety-six gallons per second, and it is determined to make the buckets on the wheel six inches apart from one partition to another, and fifteen inches deep, then six such buckets will be contained in every three feet of the wheel; therefore, ninety-six gallons must be divided by six buckets, which gives sixteen gallons for the contents of each. It will, therefore, only remain to be determined, how long a vessel of six inches wide, and fifteen inches deep, must be, to contain sixteen gallons, and this will, of course, give the necessary width of the wheel, while the number of buckets must depend upon the circumference, which is always limited by the diameter, being the extreme height, (if necessary,) that can be obtained in the fall of water; for the larger the wheel, the greater will be the power derived from it, provided a due velocity can be maintained at the same time; because the power of water on wheels, is as the square root of the height it falls through, it being regulated by the same laws as apply to solid bodies in falling. The power of every wheel, of course, depends upon the quantity of water thrown upon it, and the height from which it has to fall; but as every bucket must be filled, or every float-board struck by the water in succession, so, of course, if the wheel is too large, it will move too slowly for the purpose for which it is intended; and, in this case, the speed must be raised by cog-wheels within the mill, which, on the common principle of mechanics, must dissipate the power intended to be gained by the magnitude of the water-wheel. Hence, great attention should be paid in the construction of mills, to let the size of the water-wheel be well-proportioned, not only to the velocity of the stream, but to the speed of the work it is required to perform; and this may

always be accomplished without waste or difference of power, by using a wider wheel of small diameter, where great speed is necessary, or a narrow wheel of great diameter, when this is not essential. In every case, the full power of a stream should be taken advantage of, in the first erection of a mill, because it is a troublesome and expensive operation to increase the power of a mill, when once built; and power is always valuable.

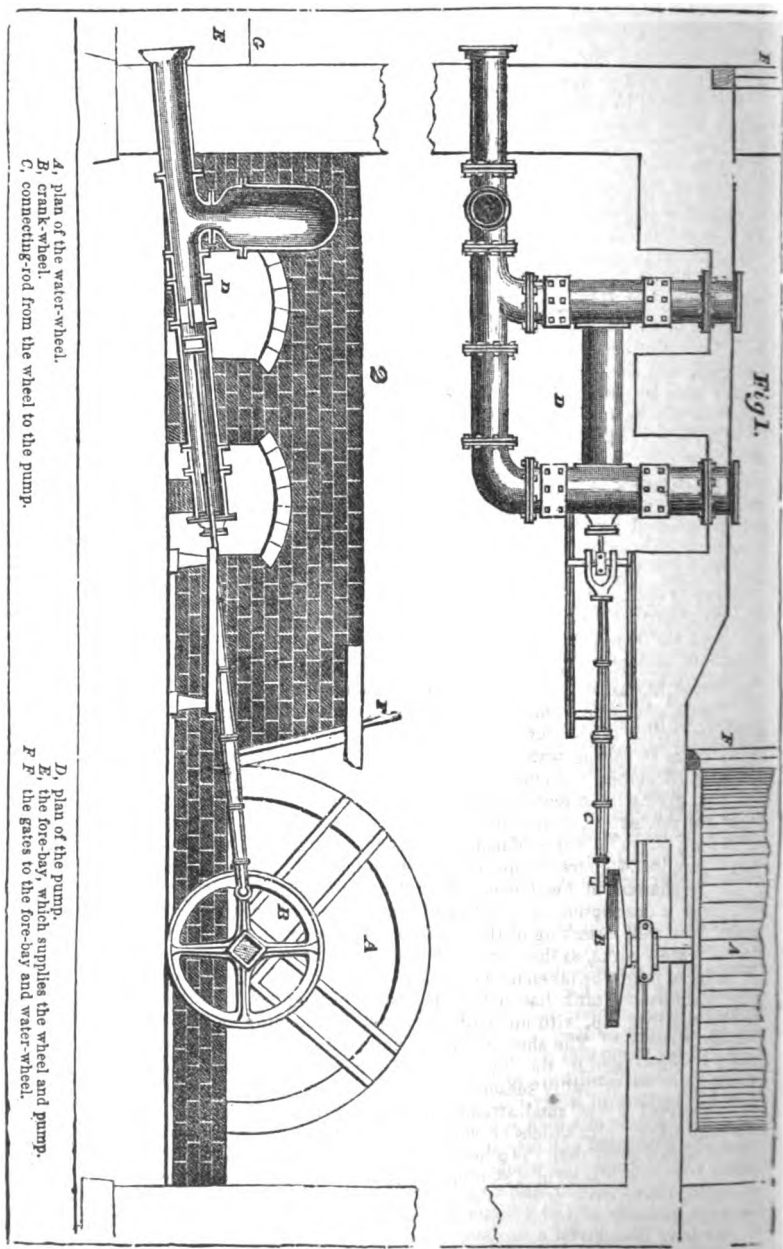
Mr. Banks, in his excellent *Treatise upon Mills*, gives many useful practical rules; from amongst which the following is selected. Being simple, it may prove useful for determining the quantity of water that will flow through a sluice or pen-stock upon a wheel, with sufficient accuracy for most purposes, because the whole motion of a stream must not be taken when it is principally dammed or stopped, and only permitted to flow through a small orifice, to produce mechanical effect.

*Rule.*—Measure the depth from the surface of the water to the centre of the orifice of discharge, in feet, and extract the square root of that depth; multiply it by 5.4, which will give the velocity in feet per second, and this, multiplied by the area of the orifice (also in feet,) will give the number of cubic feet which will flow through in a second. From knowing the quantity of water discharged, and the height of fall, not only the size of the wheel, but its extent of power may be calculated; for, in the undershot wheel, the power is to the effect nearly as 3 to 1; while in the over-shot wheel it is double, or as 3 to 2.

WATER-WORKS, denote all manner of works employed in raising or sustaining water; in which sense water-mills of all kinds, pumps, wheels, hydraulic engines, sluices, aqueducts, &c., described in various parts of the work, may be called water-works. The various water-works in and about London consist of pumps worked by steam-engines. The principal are those of the New River Company, whose works at Clerkenwell and Upper Thames-street, are said to furnish daily to 67,000 houses, 13,000,000 of gallons; the East London water-works, situated at Old Ford, also daily supply to 42,000 houses, 6,000,000 of gallons; the West Middlesex works at Hammersmith, to 15,000 houses, 2,250,000 gallons; the Chelsea works to 12,400 houses, 1,760,000 gallons; The Grand Junction, also at Chelsea, to 7,700 houses, 2,800,000 gallons. From which statement it appears that the portion of the town on the *north* side of the Thames, is supplied daily with about 26,000,000 gallons of water, and that the total number of buildings of all kinds receiving this supply amounts to about 144,000. The water is, from the great demand of certain factories, and various other circumstances, very unequally distributed; but the average consumption for each house is about 180 gallons. Of this water, more than one half of which is derived from the Thames, a large portion is delivered at very considerable elevations above the level of the river, even to the tops of the highest houses in the highest parts of London, by means of force pumps, called the *high service*, for which distinct service fifteen steam-engines are employed, exerting a power of 1105 horses.

On the *south* side of London, there are three water-companies, namely, the Lambeth, the Vauxhall or South London, and the Southwark. The Lambeth water-works are situated upon the banks of the Thames, and the water is forced immediately from the river into the mains, and thence distributed to 16,000 tenants, who consume 1,244,000 gallons daily. The Vauxhall, or South London works, situated in Kennington Lane, have about 10,000 tenants, who daily consume about 1,000,000 gallons. The Southwark works, upon the banks of the river, between Southwark and London bridges, supply about 7,000 tenants with 720,000 gallons of water. Each of these establishments has two engines, the aggregate power of which is about 235 horses. The whole of the water amounts to nearly 3,000,000 gallons, supplied to 33,000 tenants. The total quantity of water required for the whole metropolis, north and south of the Thames, is therefore about 29,000,000, supplied to 177,000 houses or tenants, making an average quantity of 170 gallons to each daily!

We have thus given a summary of a more voluminous statement that has appeared in most of the scientific journals, professedly derived from the printed report of a parliamentary commission, appointed a few years ago to inquire into



*A*, plan of the water-wheel.  
*B*, crank-wheel.  
*C*, connecting-rod from the wheel to the pump.

*D*, plan of the pump.  
*E*, the fore-bay, which supplies the wheel and pump.  
*F*, the gates to the fore-bay and water-wheel.

the subject. But we think that every resident of London, after a moment's consideration of the statement made out by the water companies, of their supply, will deem it to be a most overcharged statement of facts. Our own observation upon a great number of houses, leads us to the conclusion, that instead of 170 gallons to each house *daily*, there is not that quantity delivered *weekly* in a majority of cases, or upon an average of the whole. If the water were turned on *daily* to all the tenants, and the discharge-cocks to all the pipes were prevented from shutting during the period of "laying on," the pipes would be capable of delivering the quantity mentioned. But the facts are, that a great number of the cocks are shut, the cisterns being full; that the majority of them are only open for a few minutes, to receive an addition of a few gallons; and that, so far from being a daily supply to all, the third, fourth, and fifth-rate houses (which constitute the majority,) receive their supplies but *twice a week* at the utmost, and many of them but *once*. The official statements appear to us to be so grossly incorrect that we have not thought it needful to enter into a minute investigation. Nevertheless, we consider the supply generally to be abundant for all the purposes of health and comfort. We have already observed, that pumps are the machines now usually employed in water-works, for raising the water; and these pumps are generally worked either by steam or a fall of water. Having in other parts of this work treated of the constituents of water-works, we shall conclude this article by a brief notice of the water-works lately erected to supply the city of Philadelphia with pure fresh water, and which have been described in the recent scientific journals. "These works," Dr. Jones states, "have been admired by all who have seen them, as monuments both of the taste and skill of the persons concerned in the plan and erection of the buildings, and in the construction and executing of the machinery." The establishment is at Fair-mount, five miles above the city, at the Falls of the Schuylkill. The entire expense, including the purchase of the site, is 426,330 dollars. The water power created is calculated to be equal to raise into the reservoir, by eight wheels and pumps, upwards of ten millions of gallons daily, and it is estimated that 40 gallons upon the wheel will raise one into the reservoir. There are two reservoirs, one having the capacity of three millions of gallons, and the other of four millions. The water is raised 56 feet above the highest ground in the city, and is conveyed and distributed in cast iron pipes of American manufacture. A plan and section of the pumps and water-wheels are given in the foregoing page. The pumps are what are called double forcing-pumps, (see the article PUMPS,) producing an equal effect in raising water, in whichever way the piston moves. The working barrel is 16 inches in diameter in the clear, and the half stroke of the pump is five feet, giving a ten-foot stroke for each revolution of the water-wheel, of which there are thirteen in a minute. The water is forced to a perpendicular height of 96 feet, through mains of nearly 300 feet in length. The quantity raised by one pump, in 24 hours, is upwards of 1½ millions of gallons, ale measure.

Dr. Buchanan, in his *Journey from Madras through the countries of Mysore, &c.* gives a description of the Saymbrumbacum tank near Madras, which appears to us well deserving of the attention of persons interested in the construction of water-works, as there are probably situations in this country where similar advantages might be taken of the natural configuration of the hilly districts. The Saymbrumbacum tank has not been formed by digging, like those in Bengal, but by shutting up, with an artificial bank, an opening between two natural ridges of ground. The sheet is said to be seven or eight miles in length, and three in width, and in the dry season is let out in small streams, as wanted, for irrigation. In the rainy season it receives a supply of water from the river Chirnadî, and from several small streams that are collected by a canal. It is provided, in different places, with sluices or weirs, of stone, which are from 20 to 30 feet wide, and some feet lower than the other parts. On the surface they are strongly fortified by large stones, placed in a sloping direction, so that the water rushes over without undermining the bank, and is conveyed away from the fields by a canal. This is a matter of the utmost importance, as there are instances where, the banks of these large tanks having given way, whole villages have been destroyed



by the torrent. In order, however, that when there is plenty of rain the tank may be completely filled, a row of stone pillars is placed on the top of the sluices (weirs); and on the water rising to a level with their base, a temporary wall is formed of mud, sticks, and straw, placed between the pillars so as to confine the water till it rises as high as the top of the bank. People watch this night and day, in order to break down the temporary bank should any additional rain endanger the whole. The water is let out to supply the fields, by a sluice lined with cut stone or bricks, formed through the bank, on a level with the country. The inner end of this sluice is covered by a flat stone, in which is cut a conical opening, that can be shut or opened by a conical plug or valve, fixed to a bamboo staff, and which is secured in its place by passing through holes made in cross guiding-bars, let into two pillars of stone, which rise above the level of the water in the tank. This tank is said to be sufficient to supply with water the lands of thirty-two villages, for eighteen months, should the rains fail; such a reservoir is therefore of inestimable value.

**WAX.** An oily concrete matter, usually considered to be gathered by bees from plants; though Huber, who was a close observer of nature, and the habits of bees in particular, asserts that wax is an artificial production, made by the bees from the honey they collect; that they cannot procure it, unless they have honey or sugar for the purpose; and that raw sugar affords more than honey. Wax was long considered to be a resin, from some properties which it possesses in common with resins. Macquer found that wax resembles resin only in being an oil, rendered concrete by an acid; but that it differs essentially from these in the kind of the oil, which, in resins, is of the nature of essential oils, while in wax, and other analogous oily concretions, (as butter of cocoa, butter of milk, fat of animals, spermaceti, myrtle wax,) it is of the nature of mild unctuous oils, that are not aromatic, and not volatile, and are obtained from vegetables, by expression. Dr. Ure considers it probable, that the acidifying principle, or oxygen, and not an actual acid, may be the leading cause of the solidity, or low fusibility of wax; but it has been observed, that by digesting the nitric or muriatic acid upon fixed oils, the oils pass into a state resembling wax. The natural colour of wax is yellow, and it is whitened by exposure, in thin laminae, to the air and sun. Alkalies dissolve wax, and render it miscible in water. In China and North America, wax is procured directly from plants, and is then called vegetable-wax. In order to obtain bees' wax in a pure state, what remains of the combs, after separating the honey, is put into a copper, with a quantity of water, which is made to boil over a slow fire, and stirred frequently with a stick. When the wax has been thus thoroughly melted, it is strained through canvas bags, and the residue in the bags is forced out by a press, whilst hot, and received into a vessel of water. When all the wax has been thus cleared of the grosser impurities, it is again melted over water, and the scum which arises in the boiling is carefully skimmed off; after which, it is poured into pans or moulds of the size required, to solidify. Wax keeps better in large cakes than small ones: any sediment that may remain at the bottom of the cakes is scraped off before bleaching.

The ordinary process of bleaching wax, consists in first melting it at a low heat, in a cauldron, from whence it is allowed to run out by a pipe at the bottom, into a capacious vessel filled with cold water, in which is fitted a large wooden cylinder, that is made to turn round continually on its axis, upon which the melted wax falls. The surface of the cylinder being constantly wet, the wax does not adhere to it, but lays solid and flat, acquiring the form of ribbands. The continual rotation of the cylinder carries off these ribbands as fast as they are formed, and distributes them through the tub. The wax is then put upon large frames covered with linen cloth, which are supported about eighteen inches above the ground, in situations exposed to the air, dew, and the sun. The thickness of the several ribbands, thus placed upon the frames, ought not to exceed an inch and a half, and they ought to be removed from time to time, in order that they may all be equally exposed to the action of the air. If the weather be favourable, the colour will be changed in a few days. It is then to be

re-melted, formed into ribbands, and exposed to the air as before. These operations are to be repeated, until the wax is rendered perfectly white; after which it is to be melted into cakes, or formed into candles.

Of late years, the sulphuric acid, and other chemical agents, have been proposed for shortening the process of bleaching wax, but we are inclined to believe that they have not been successfully carried into practice, as the manufacturers, we are informed, adhere to the old process above described. To what extent chlorine has been applied to this purpose, or in what manner, we are not informed; but the process employed by Mr. Davidson, of Glasgow, and recently patented by him, is stated, in the specification, to be as follows:—

“The wax or tallow is heated to about the temperature of boiling water, in an iron vessel lined with lead, when the oxymuriate of lime, (chloride of lime,) or the oxymuriate of magnesia, (chloride of magnesia,) is to be added, either in solution with water, or in the dry state, and then intimately mixed and well stirred up with a wooden spatula. When these materials have acted upon each other a sufficient length of time to discharge the colour from the wax or tallow, the lime or magnesia is to be removed, by adding dilute sulphuric acid, or some other acid possessing a greater affinity for those earths than chlorine. The whole is then to be boiled, until the earth employed is separated.”

For the bleaching of wax, the solution of the chloride is to be in the proportion of from 14 to 28 pounds of the salt, to 112 pounds of water; and an equal quantity by weight, of the solution and of the wax, to be employed in the process. The sulphuric acid should be of the specific gravity 1.8485, and be diluted with from twenty to thirty times its weight of water.

For the bleaching of tallow, a solution of chlorine, of less strength than the above, will suffice, and the sulphuric acid should be more plentifully diluted: but the proportions necessary, will vary both in the wax and the tallow, according to the quantity of colouring matter that may be combined with them. The following formulæ for the composition of the various kinds of sealing-wax, will not be out of place:—

The best hard red wax for sealing letters:—Mix two parts of shell-lac, well powdered, with resin and vermilion, each one part, and melt this combined powder over a very gentle fire: when the ingredients are thoroughly incorporated, work the mass into sticks. Seed-lac may be substituted for shell-lac; and instead of resin, boiled Venice turpentine may be used. Coarse hard red sealing-wax:—Mix two parts of resin, one part of shell-lac, vermilion and red-lead together one part; the latter in the proportion of one of vermilion to two of the red-lead. For a cheaper kind, the vermilion may be omitted, and for very coarse uses, the shell-lac also. Black sealing-wax is made in the same manner as red, with the exception of the colouring; the colouring ingredient for black wax, being the finest ivory black. Hard green sealing wax is the same mixture of resins and gum-resins as before-mentioned; the colouring ingredient is powdered verdigris; for a brighter colour, crystals of verdigris. Blue sealing-wax:—Use smalts, light blue verditer, or a mixture of both. Yellow sealing-wax:—Use massicot; for a fine bright yellow, turbith mineral. Purple sealing-wax:—Use half vermilion, and half smalts, or red and blue in various proportions, according to the tint required.

Particular attention should be paid to the ingredients, while over the fire, that no more heat be given than is just sufficient for them to melt, and be thoroughly incorporated. The wax is formed into sticks, by rolling it on a copper plate or stone, with a rolling-board lined with copper or tin, into rolls of any required size. The polish or gloss is given afterwards, by placing the sticks of wax over a fire in a small stove, which is provided with a suitable apparatus for placing and turning them in that situation, where the heat given to them is just sufficient to melt the surface of the wax, and produce the gloss.

A patent was recently taken out by Mr. Wason, of the Middle Temp.e, for introducing a small wick into the middle of the sticks of wax, for the convenience of sealing letters. These sealing-wax candles we do not, however, perceive in the shops.

WEAVING, is the art of working a web of cloth from silk, cotton, or other

fibrous thread, in a loom, with a shuttle. The principle of the art may be said to consist in crossing two sets of threads at right angles to each other; and it was probably first conducted in an extremely coarse and simple manner, like the interlacing or plating of rushes to form mats. An uninformed savage having effected thus much, would naturally be led to operate upon finer materials, which nature might present to his hands, and he would be able to weave them with the same, or nearly the same facility, as he did the coarse matting; the assistance which he might receive from a fellow-labourer, in perhaps opening the threads of his warp with a piece of stick, or in thrusting the weft through its interstices; would naturally suggest the use of sticks, for opening the alternate threads of the warp, and beating up the weft. For want of assistance, our primeval weaver might fasten the ends of his warp, which we will conceive to have been long stripes of the inner bark, to the stumps or boughs of trees. With his sticks he would then be able to operate with comparative rapidity and excellence; and as it could not fail to escape his notice, nor that of the by-standers, that the alternate threads of the warp, divided into two distinct sets, were alternately raised and depressed by the sticks, and that, sometimes, from accidental circumstances, some of the threads of the warp were raised or depressed by a pull instead of a push; hence we may imagine that some contrivance resembling or performing the same office as the treadles or lams of our present looms, were resorted to; thus we have a complete, though rude machine, excepting the shuttle; the gradual steps to which pretty contrivance must obviously have been made, by the weaver first poking, next sliding, and, finally, as his manual dexterity increased, *throwing* the weft.

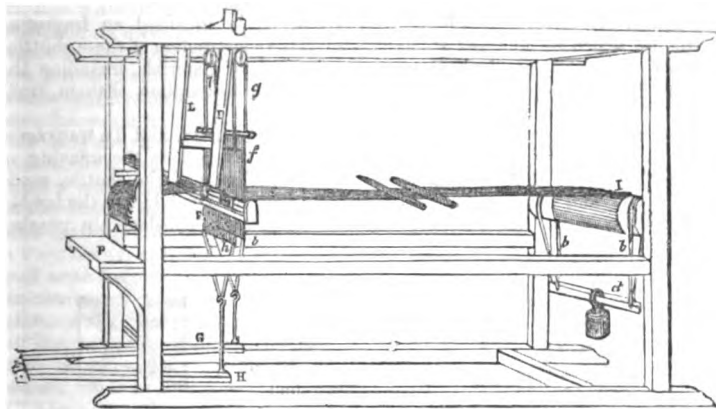
As the early history of weaving is involved in total obscurity, we have thus endeavoured to trace the probable origin and earliest practice of the invention, and at the same time explain the really simple process of which plain weaving consists. In fact, the process is even now conducted in India, and many of the eastern nations, by similar means; the weaver performs his labour in the open air, choosing his station under trees, whose shade may protect him from the scorching rays of the sun. Here extending the threads which compose the warp of his intended cloth lengthwise, between two bamboo rollers, which are fastened to the turf by wooden pins, he digs a hole in the earth large enough to contain his legs when in a sitting posture; then, suspending to the branch of a tree the cords which are intended to cause the reciprocal rising and depressing of the alternate threads of his warp, he fixes underneath, and connected with the cords, two loops, into which, inserting the great toe of either foot, he is ready to commence his operations. The shuttle with which he causes the cross threads or woof to interlace the warp, is in form like the knitting needle, and, being somewhat longer than the breadth of the warp, is made to perform the office of a baton, by striking the threads of the woof close up to each other. With this rude apparatus the patient Indian succeeds in weaving fabrics which, for delicacy of texture, cannot be surpassed, and can hardly be rivalled, by the European weaver, even when his labours are aided by the most elaborate machinery.

The machinery by which the process of weaving is conducted in this country varies but little, whatever may be the material of the fabric; the difference in looms for weaving silk or wool, chiefly consisting in the greater stability and strength of the latter, on account of the greater coarseness and elasticity of fibre and the thickness of the cloth woven.

Of late years there have been numerous and great improvements in weaving machinery, and these have, to a great degree, superseded the mechanism of the last century. Nevertheless, the old-fashioned common loom, for weaving plain silks, being still extensively used, especially in Spitalfields, we shall commence our account of the mechanism employed, by giving a description of it.

A, in the annexed figure, is a roller called the cloth-beam, on which the cloth is wound as it is wove; at one end it has a ratchet wheel, and a click, to prevent its running back; at the same end it has also four holes in it, and is turned by putting a stick in these holes: at the other end of the loom is another roller I, on which the yarn is wound; this has two small cords *b b*

wrapped round it, the ends of which are attached to a bar *d*, which has a weight hung to it; by this means a resistance is caused, which prevents the roller *I* turning by accident. *F f* are called lames; they are each composed of a pair of sticks, between which are fastened a great number of threads; to the bar *e* are fastened two cords *g l*, which pass over pulleys, and are fastened to the bar *h* of the lame *F*; the lower bars of each lame are connected by cords with the treadles *G H*; the workman sits on the seat *P*, and places his feet upon these treadles: as they are connected together by the cords *g l*, when he presses down one, it will raise the other, and the lames with them; a great number of threads, according to the width of the cloth, are wound round the yarn beam *I* and are stretched to the cloth-beam *A*; the middle of the threads

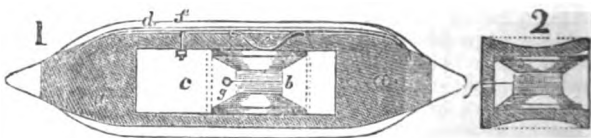


which compose the lames *E F*, have loops called eyes in them, through which the threads between the rollers, which are called the warp, are passed; the first thread of the warp goes through the loops of the lame *E*, the next attached to the lame *F*, and so on alternately; by this means, when the weaver presses down one of the treadles with his foot, and raises the other, one lame draws up every other thread, and the other sinks all the rest, so as to make an opening between the sets of thread. *L L* is a frame moving on a centre at the top of the frame of the loom; *L L* are the two uprights of the frame; *l* is the bar that connects them; *M* is a frame carrying a great number of pieces of split reed, or sometimes fine wire, at equal distances; between these the threads of the warp are passed; the frame being supported by a piece of wood called the shuttle-race, which is fastened into the front of the pieces *L L*; each end of this piece has boards nailed to the sides, so as to form troughs; at a small distance above these are fixed two very smooth wires; their use is to guide the two pieces *p q*, called peckers or drivers; to each of these pieces a string is fastened; and these strings are tied to a piece of wood, which the weaver holds in his hand, and, by snatching the stick to either side, draws the pecker forwards very quick, and gives the shuttle (which is to be laid in the trough before the pecker,) a smart blow, and drives it along across the race *m* into the other trough, where it pushes the pecker along to the end of the wire, ready for the next stroke, which throws it back again, and so on. The ends of the shuttle are pointed with iron; it has a large mortise through the middle of it, in which is placed a quill containing the yarn; also a glass eye, having a hole in it, through which comes the end of the thread; and two small wheels to make it run easily on the race. The operations are as follow:—The workman, sitting upon the seat *P*, holds the stick in his right hand, and takes hold of one of the bars of the frame *L L* with his left; presses his foot on one of the treadles *G H*, which by means of the lames *E F*, as before described, divides

the warp ; he then relieves the treadle he before kept down, and presses down the other ; while he is doing this, he with his left hand draws the frame L L towards him, and then returns it. The use of this is to beat the last thread thrown by the shuttle close up to the one that was thrown before it, by the split reeds. As soon as he has brought the frame L L back to its original position, and again divided the warp by the treadle, he throws the shuttle again ; when he has in this manner finished about twelve or fourteen inches of cloth, he winds it by turning the roller A with the stick, as before described. Some very expert weavers will throw the shuttle, and perform the other operations, at the rate of 120 times per minute.

In shuttles of the common kind, great difficulties have been experienced in causing the thread or yarn to come off the bobbin or shuttle-cap with an uniform tension, without which it is impossible to produce a good and even cloth ; to remedy this defect, Mr. Gosset, of Clerkenwell Green, lately invented an improved shuttle, for which he obtained a patent ; and as the construction of these shuttles renders them equally applicable to weaving all kinds of materials, including the metallic cloth, or wire gauze, we annex the following description of them, from the specification :—

In the annexed figures, 1 represents a longitudinal section, and 2 a transverse section of the improved shuttle ; in this example, adapted to the weaving of metallic fabrics, or other stiff materials, *a* is the body of the shuttle, made of hard wood, and tipped with metal at the extremities, as usual ; *b* is the bobbin or weft roller, made like a pulley, and turning upon a polished pin passing



through its axis, in the morticed cavity *c*, made in the side of the shuttle ; the pin *b* is adapted to be taken out easily, that the bobbin may be removed or changed with facility, as often as may be desired ; *d* is the regulating spring before mentioned, the ends of which are bent round and fixed, by driving them into the wood. To this large spring is fixed a smaller spring *e*, so curved as to bear and press upon the upper surface of the bobbin ; at *f* is an adjusting screw, the head of which is sunk into the upper part of the regulating spring *d*, to prevent its becoming entangled with the threads of the warp ; the point of this screw is inserted, and works in a fixed nut in the inside of the shuttle, so that, when it is turned, the small curved spring is caused to press with more or less force upon the surface of the bobbin, thereby creating a greater or less degree of resistance for regulating the tension at which the yarn shall be drawn off the bobbin, and through the eye *g*, of the shuttle. The upper and lower surfaces of the shuttle are formed concave, (as shown by *Fig. 2.*) in order that the head of the adjusting spring may be sunk within it, so as to prevent their coming in contact with the threads of the warp. The regulating spring is in some cases applied by the patentee within the cavity *c*, when a hole is made in the upper part of the shuttle, for the insertion of a turn-screw, to operate upon the head of the screw *f*, and regulate the tension. By another modification, the patentee forms the shuttle like a box, with the lid sliding in grooves, or hinged on ; in which case the regulating spring is to be fixed on the lid, or one of the sides, so as to give the required pressure to the bobbin. In weaving articles of stiff wire, with this improved shuttle, a casing or tube of some elastic substance is employed to surround the bobbin, shown by dotted lines ; this tube has an opening or slit on one side, for the wire to pass through ; and by closely embracing the bobbin, prevents the coil of wire from unwinding, becoming loose, or entangled, and allows it to be drawn off evenly and regularly, as it may be required. When the wire is very stiff and hard, the patentee recommends the employment of a

pair of small steel rollers, to be fixed near the eye-holes, by which means the wire will run out with considerably less friction.

The annexed form of shuttle is adapted to the weaving of fabrics of silk or any other material. It is hollowed out, as described in the former, for the reception of the bobbins, which are three in number; these bobbins being charged with the thread or yarn, may be worked, one after another, with the same coloured thread, or with thread of different colours successively, for weaving

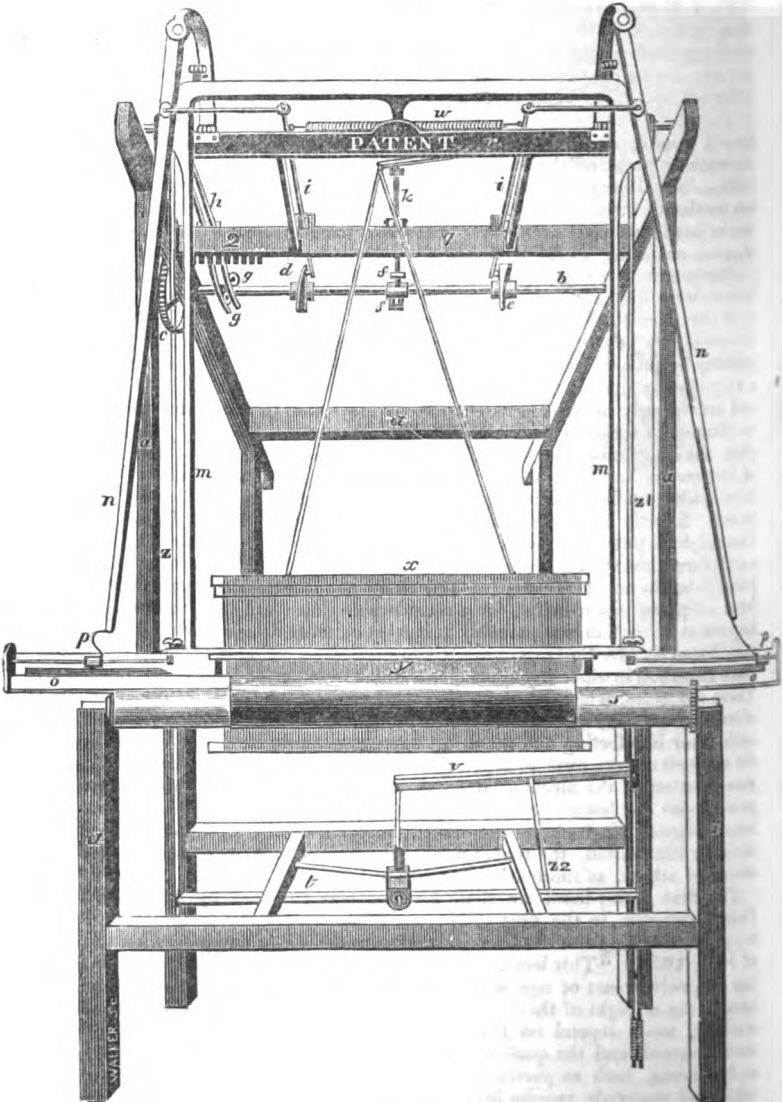


figured goods; and when it is necessary to change the colour, it will only be requisite to break off the end of the weft done with, and draw the end of the other colour through its eye or opening. The springs and screws in this shuttle are similar to those described in the first-mentioned shuttle, and therefore need not be particularized again. Any number of bobbins may be employed in these shuttles, according as the nature of the work may render desirable.

Power-looms, or such as are worked without the intervention of manual labour, were first suggested by Vaucausin, in 1747, but the subject was neglected until the year 1784, when the idea occurred to the Rev. Edmund Cartwright, of *weaving by power*, in consequence, it appears, of the success of Awkright in *spinning by power*. He commenced the construction of a loom, which, although a very clumsy machine, satisfied him of the practical efficiency of the principle; and accordingly he took a patent for his invention, in 1785, and subsequently he obtained a series of fresh patents for successive improvements upon the original plan. At length, in 1790, the first manufactory with power-looms was established at Doncaster, in Yorkshire, which was worked by a steam-engine; and in it were made muslins, calicoes, and other fabrics, equal to those made by hand-looms. Shortly afterwards, a Mr. Grimshaw attempted the introduction of Cartwright's power-looms into Manchester; a large factory was erected, and partly furnished with the machinery, when the whole was burnt to the ground, supposed to be the act of incendiaries. This circumstance deterred other manufacturers from adopting power-looms, for a considerable time; and the prosecution of this important invention was probably in a great measure delayed by the indifference manifested by Mr. Cartwright himself to the matter, owing to his mind having become absorbed in other inventions, from which he expected more gratifying results. These obstacles, which beset the invention of the power-loom at the early stage of its introduction, were by degrees surmounted, and manufacturers vied with each other in effecting and maturing improvements in its details, which became the subjects of very numerous patents. A faithful description of only the meritorious portion of the mechanical combinations and curious movements that the power-loom has been the cause of bringing into operation, would alone fill a large volume. In making a selection, therefore, of one or two of those inventions for illustration, the reader must not consider them as detracting from the merits of others, as there are many of equal intrinsic worth.

The first power-loom we shall describe was patented by Mr. Kendall, of Paternoster-row, in the year 1825: our attention was drawn to the subject of it by the following notice of the invention in the *Times* newspaper, on the 24th of June, 1836. "This loom," the editor observes, "is effectual and simple: a boy of twelve years of age, with a proper fly-wheel, would find no difficulty in turning six or eight of them. The number of looms one weaver is capable of working, must depend on two principal objects. The quality of the goods manufactured, and the quality of the materials made use of, varying from two to five looms, such as persians, sarcenets, levantines, and poor satins, which, with good materials, require little attention. Rich works, with an able weaver, and good materials, will be able to work two looms, with an addition of some light work before mentioned. The work is, of course, better than that performed according to the old plan, by hand,—the machine acting more steadily, and operating with less of stickings." Having called upon the patentee, in conse-

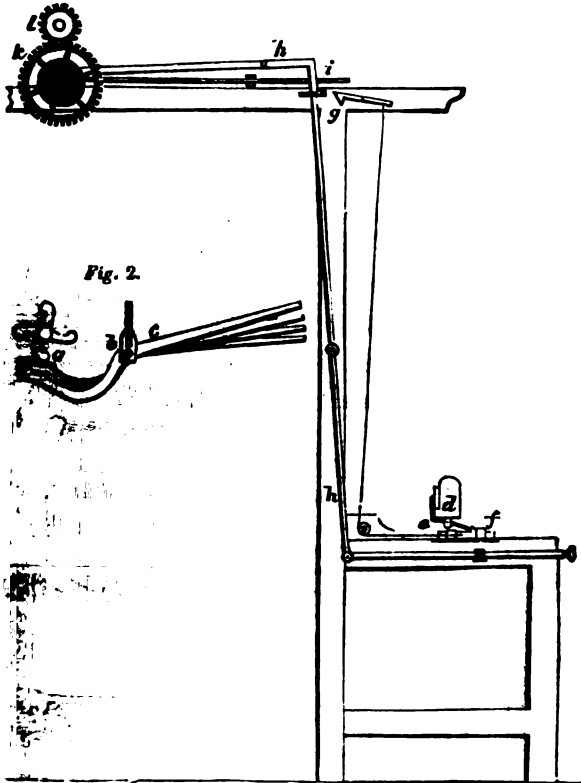
quence of the foregoing remarks, he very politely afforded us demonstrative proofs of the correctness of the foregoing statement, by allowing us to turn a winch, by which two looms were put into operation, and we wove thereby a portion of two very rich figured silks, with so much ease as to require the

F<sup>g</sup>. 1.

application of only one hand. Viewing the loom distinctly from the power applied, it is in all respects of the same construction, and operates exactly the same as the common hand-loom; and every description of fabrics can, in like

manner be woven by it: herein consists one of its chief excellencies; for a weaver, who has never seen a power-loom in his life, may at once proceed, without any instruction, to arrange the several matters preparatory to the act of weaving, in the manner he has been accustomed; and afterwards see all the combined and successive movements in weaving executed with the utmost precision.

*Fig. 1* in the foregoing engraving exhibits a front view of Kendall's power-loom, in which all the principal parts may be seen; *a a a* is the framing, *b* is a revolving shaft or bar, which is put in motion by the action of a pinion, (particularly shown by *Fig. 3*.) taking into the spur-wheel *c*; *d* and *e* are two cams which act upon the levers *i i*, the same being connected to the spiral spring *w*, to give motion to the shuttle. *ff* are two wipers, which operate on the batton lever *k*. *gg* are two other wipers, acting upon the two treadle levers *h*. *ll* are the tumblers, which raise and depress the harness. *mm* are the swords of the battons. *nn* are two vertical rods in connexion with the shuttle. *oo* is the box or shuttle-race. *pp* are the drivers sliding upon horizontal wires, which immediately propel the shuttle. *q* is an iron bar, carrying various levers as above-mentioned. *r* is the front bar, supporting the brackets which carry the vertical rods. *s* is the breast-roll. *t*, the long marches. *v*, the short marches.

*Fig. 3.**Fig. 2.*

*x* is the harness and heddles. *y*, the reed or slay. *z*, the cords connecting the two treadles with the long marches. *z 1*, the cords connecting the long with the short marches; and *z 2*, those which connect the long marches with the

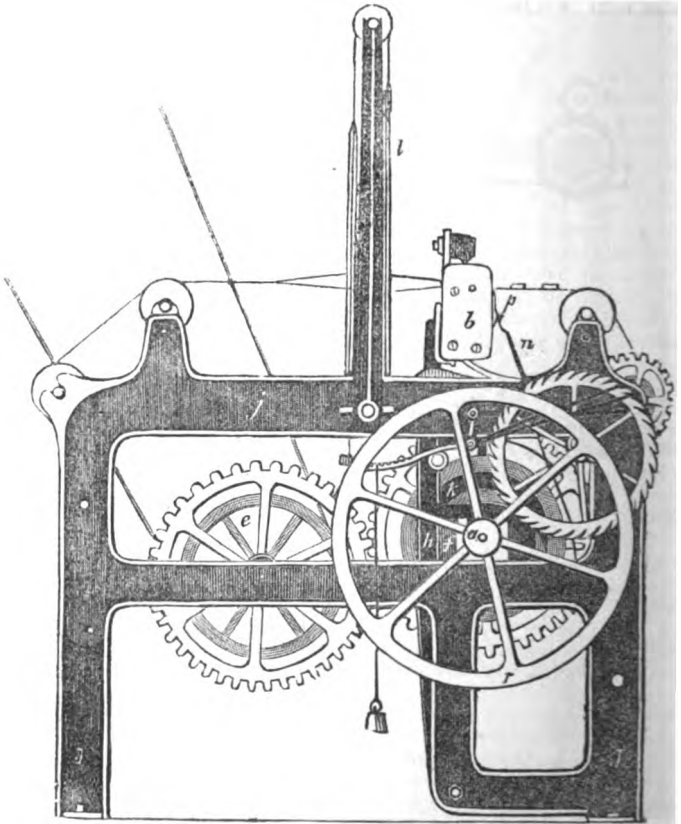


tumblers. The several small spiral springs represented, are for the purpose of giving steadiness, and the necessary tension to the parts, with which they are connected.

*Fig. 2* represents a series of treadles, (which may consist of any number, as required,) with the end view of an additional bar, which it is necessary to introduce, when the weaving is of such a nature as to require the operation of more than two treadles: in *Fig. 1* is shown a series of notches or bearings for these treadles, (marked 2 upon the bar *g*;) this bar in *Fig. 2* is shown equipped with four wipers *a*, which act successively upon the four treadles *c* beneath.

The intention of the diagram *Fig. 3* is to show the method adopted by the patentee, for throwing the revolving shaft in and out of gear, and likewise to exhibit the mode by which the power is applied. *d* is the box of the batton. *e* is a small bent lever, attached to the box. *f* is a sliding-bolt connected to a latch *g*, by a cord. *h h* is a long right-angled lever, furnished at the extremity with an inclined plane, for the purpose of putting the wheel in and out of gear. *i* is the lever connected with the clutch, and is operated upon by the lever *k*.

*Fig. 4.*



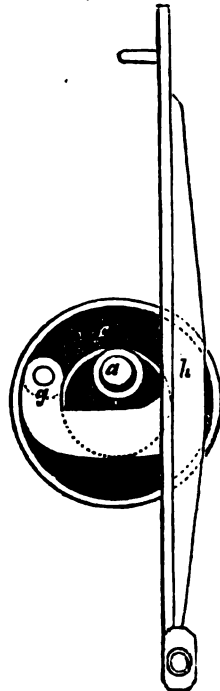
The action of this machine is wholly effected by the revolution of the bar *k*. *Fig. 1*, in the top of the loom, which, as already described, is equipped with four wipers, and two cams or snails. The two central wipers, as they revolve, operate on the lever *k*, and move the batton *m m*, as required; the two

cams  $e$   $d$ , right and left, act alternately on a lever each,  $i$   $i$ ; the reverse ends of these levers are connected to two vertical rods  $n$   $n$ , suspended from a bracket in front of the loom; these levers  $i$   $i$  are likewise connected by a spiral spring  $w$ , that the action of the cams at the necessary periods may cause the springs to become charged, at the time the levers in traversing the cams meet with a sudden declension or fall, when the distended spring suddenly contracts, and drives the shuttle across the work. The other two wipers  $g$   $g$ , act upon two treadles  $h$   $h$ , to make the shed or opening for the passage of the shuttle; one revolution of this bar completes two shoots, causing these cams and wipers to act uniformly with each other, and to perform the whole operation required in simple weaving.

In order to accomplish more complex weaving, when more than two treadles are required, a second bar is introduced, equipped with as many wipers as treadles wanted; the wipers being placed at equal distances on the circumference of the bar. If four are necessary, as the principal bar, in making one revolution, acts upon the treadles twice; therefore, in order to work over the four treadles upon the second bar, the principal bar in this case must make *two* revolutions to *one* revolution of the secondary bar. If five treadles be required, the principal bar must make two and a half revolutions to one of the secondary bar; and so on, to any number of treadles used in "plain complex weaving." The uniform motion of the two bars are regulated by cog-wheels upon their axes, which are adapted according to the nature of the work. If a greater number of treadles be required, than the hand-loom is able to accomplish, with ease, it only requires the aid of the jacquard, mounted upon the loom, to simplify the "complex-figured weaving."

The next power-loom we shall describe, is the invention of M. De Bergue, a French gentleman, who, it appears, came to this country with it, under the impression, that similar inventions had not previously occupied the attention and skill of British mechanists; and there are, undoubtedly, in several of his combinations, a considerable degree of originality and ingenuity of design. This loom we have also had several opportunities of seeing at work, and can confidently state, that it operates in a very efficient manner. The engraving on the preceding page, marked *Fig. 4*, affords a side elevation of the machine, and will be sufficient, with the subjoined and following diagrams, to explain the construction.  $a$  is the shaft of the loom, by the rotation of which all the various motions are either simultaneously or successively produced. The rotation of this shaft is effected either by hand applied to the lay, which constitutes it a *hand-loom*; or by means of a band or strap, from another shaft at  $c$ , passing over drum-wheels or pulley, as shown by that at  $e$ , and the bands proceeding therefrom, which makes it a *power-loom*. The axis of the drum  $e$  carries a spur-wheel, which gears into another on the shaft  $a$ , and its rotation gives motion to two eccentrics  $f$ , fixed at each of the shafts within the frame. This motion is shown in the annexed engraving, *Fig. 5*, where the letter  $a$  also indicates the shaft, and  $f$  the eccentric turned round by it: in the annular path or race  $f$  is a friction-roller  $g$ , attached by a bent arm to a vibrating lever  $h$ , the upper end of which is fixed fast to the lay, and the lower end turns upon a centre or pivot, passing through the side frame of the loom; the eccentric revolution of  $f$  therefore causes the lever  $h$  to vibrate, and with it the lay, in that very steady and uniform manner, so essential to good weaving.

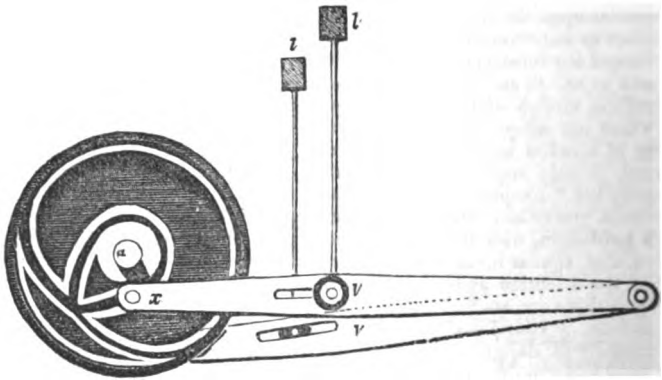
*Fig. 5.*



In the middle of the shaft *a*, is a broad wheel, (not shown,) in the periphery of which are made two deep grooves, so inclined to each other as to cross in the middle, like the letter X: in these grooves a projecting pin from the shuttle-rod works, so that, by the revolution of the wheel, the said pin traverses the X groove from side to side, and the shuttle-rod, turning upon a fulcrum just above it, is thrown from side to side alternately; and the upper end of the said rod being connected by cords to drivers which slide upon a polished wire, fixed in a channel of the lay. The shuttle is impelled backwards and forwards through the warp by means of the treadles, which are worked by a peculiar eccentric movement, as will be explained by reference to the annexed Fig. 6.

At *ll*, the ends of the levers, (seen in section,) are connected to the horizontal levers *v v*, (answering to the treadles of the common loom,) which turn

Fig 6.



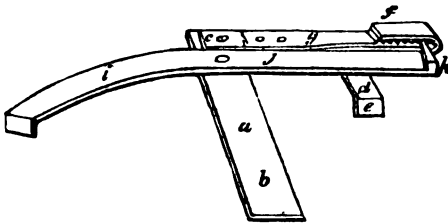
upon a joint at the back of the looms. The other ends of the levers are furnished with steel pins *x*, which work in two eccentrics having the peculiarly shaped grooves delineated in the figure, as the said eccentrics revolve upon their central axis *a*; the revolution of these eccentrics, it will be perceived, causes the steel pins alternately to traverse along the external groove, and then the internal heart-shaped groove, which produces that peculiar vibration in the bars *v v*; and the required reciprocation of the lames *ll*, to open the threads of the warp after each successive shoot. The reed or cane, which is the immediate instrument for beating up the threads of the woof, is situated in the lay or batton. The cloth as it is woven passes over the breast-beam, and winds itself on the roller, which receives its motion by a toothed wheel fixed upon it, and a pinion upon the same axis as the ratchet-wheel.

In a lecture delivered by Dr. Birkbeck, at the London Mechanics' Institution, on the subject of weaving, this loom was publicly worked, when it was found to weave at the rate of a yard and a quarter per hour of gros de Naples.

Some successful attempts have recently been made to produce a figured or rather variegated pattern in silks by plain weaving. It is effected by composing the weft or woof of two different coloured threads twisted together; which may be of silk, of silk and worsted, or of linen, cotton, and silk, variously combined. The more the colours are contrasted, the more brilliant, of course, is the effect. Long specks or spots are produced by twisting the threads very slightly, and short or minute ones by a hard twist. The warp of the fabric, as well as the shoot are composed of a similar or different arrangement of threads, and thus by slight variations, a great diversity of pretty patterns may be obtained.

A patent was taken out in 1833 by Mr. W. Graham of Glasgow, for "a

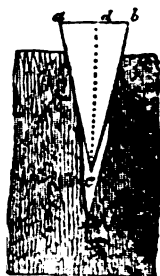
self-acting *temple* to be used in the operation of weaving by power or hand looms," for the purpose of keeping the fabric at the width the reed leaves it. The invention consists in an apparatus affixed near each end of the breast-beam, which, being acted on by the swinging of the lay in beating up the west, are caused to open and shut, and, by means of these apparatuses, the cloth is held to the width at which the reed leaves it after beating up the west.



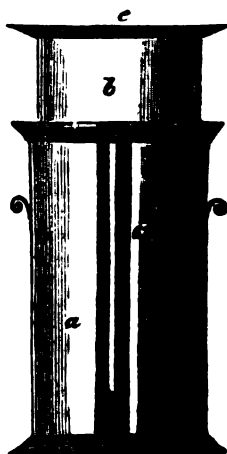
The above is a perspective view of the apparatus. *a*, is a plate which is affixed to the breast-beam of the loom at the slot at *b*, by means of a screw-bolt passing through the breast-beam; and where different widths of fabric are woven in the same loom, the temples must be so constructed as to allow of being brought nearer to, or farther from each other, by means of the slots formed in the plate *a*. On to the plate *a* is fixed, by means of a screw, another plate *c*, having a projection *d*, which is turned down at right angles at *e*, the object of which will be hereafter described. The outer end of the plate *c* is turned over, so as to produce a parallel plate *f*, having a space between them; *g* is a spring affixed to the plate *c*, by rivetting or otherwise, and on the face of this spring is formed teeth or grooves, cut in a line with the direction of the cloth, these teeth or grooves being intended to hold the cloth when the spring is pressing upwards against the plate *f*; *i* is a lever, which has its fulcrum at *j*, on the plate *a*; and at one end of the lever *i* is formed a projecting wedge *k*, which is pressed between the upper plate *f* and the spring *g* every time the lay beats up the west, by the lay coming in contact with the other end *b* of the lever *i*, this and *l*, being turned down, as shown in the drawing, for that purpose. There is to be one of these apparatuses placed near the breast-beam, that is, in such a position that they shall just embrace the outer edges or selvages of the fabric, between the plate *f* and the spring *g*, and they are so placed as to take hold of the fabric as near as possible to the point at which the reed strikes up the west; but the reed is prevented being injured by the bottom of the lay coming in contact with the parts *e*, which stops the lay from approaching too near to the temples at the beating up the west; and at the time the lay has nearly finished its stroke it comes against the part *l* of the lever *i*, which drives the wedges *k* between the plates *f* and the springs *g*, and causes them to separate to permit the fabric being drawn through them; but immediately on the receding of the lay, after having beaten up the west, the springs *g* will press up against the plates *f*, and retain the cloth between them, the wedges *k* being forced out by the pressing up of the springs, and by this means the fabric will be kept to the width at which the reed leaves it.

**WEDGE.** A simple machine, of great utility in cases where an immense pressure and little motion are required. The wedge may be considered a modification of the inclined plane, to which in many cases it is strictly analogous, differing only in the circumstance that the body to be moved is drawn along the surface of the plane; but in the wedge the plane is made to move by percussion beneath the body to be raised, or between the surfaces to be separated. Wedges are frequently employed for splitting masses of timber or stone; ships are raised in docks by wedges driven under their keels. Sometimes they have been employed to restore a declining edifice to the perpendicular position. Ir.

the annexed cut the wedge  $a c b$  is employed in cleaving wood, and its mechanical power is estimated by the proportion of  $a b$  to  $d c$ . This is sometimes differently stated, and it is difficult to state positively what is the exact power obtained by the use of the wedge, as it is generally driven by blows of a mallet or hammer; there can, however, be no doubt that the penetrating power is increased by increasing the length  $d c$ , in proportion to the breadth  $a b$ . The wedge, in part, owes its value to a quality which, in most machines, is a diminution of their effect, *i. e.* the friction that arises between it and the substance it divides. Were it not for the immense friction which obtains in the use of the wedge, it would recede to its original position, between the successive blows, and thus no progress would be made. Instead of this, however, we find the pressure and adhesion of the surfaces prevent the recoil, and thus a succession of slight blows effect a result which previously might have been supposed beyond human power to realize. All cutting and piercing instruments, as knives, chisels, razors, nails, pins, &c., may be considered as wedges. The angle of the wedge, in these cases, is more or less acute, according to the purposes to which it is to be applied. The mechanical power of the wedge is of course increased by diminishing the angle, but as this diminishes the strength of the instrument, there is a practical limit to this increase of power. In tools intended for cutting wood the angle is generally about  $30^\circ$ . For iron it is from  $50^\circ$  to  $60^\circ$ ; and for brass from  $80^\circ$  to  $90^\circ$ . Tools which act by pressure may be made more acute than those which are drawn by percussion, and in general the softer the substance to be divided, and the less the power required to act upon it, the more acute may be the construction of the wedge.



**WEIGHING-MACHINES** have been described by us under the article **BALANCE**, in which article, however, we have omitted a notice of the annexed singular but simple and useful contrivance, the invention of Mr. Hawkins, of Fleet-street. It is called the hydraulic weighing-machine, and is chiefly designed for domestic use.  $a$ , in the annexed figure, denotes a cylindrical vessel made of tin and japanned, and partly filled with water;  $b$  is another cylinder of the same kind, but of less diameter, resting upon, or floating in the water contained in  $a$ ;  $c$  is a graduated scale, with a glass tube running up the middle, fixed to the exterior cylinder; the bottom of this tube opens into the lower part of the cylinder, therefore the water always stands at the same level in both.  $e$  is a dish or scale, for holding the article to be weighed, the pressure on which causes the internal cylinder to sink lower, and raise the water higher between the two vessels, the level of which is indicated by the tube, and the weight at such level exhibited on the scale. There is of course a liability to change, by a portion of the water evaporating: but, by leaving a weight in the scale when not in use, and pouring in of a small quantity of water occasionally to bring it to the level of the mark on the scale, an adjustment is easily made.



**WEIGHT.** The force by which bodies in air press towards the centre of the earth; and the measured quantity of that force, in any body, is the weight of it. The earliest attempt on record to define measure of capacity and weight, by referring them to some natural standard, was made in the 51st year of the reign of Henry III., A.D. 1266; it is as follows:—

“ An English penny, called a sterling, round and without clipping, shall weigh

thirty-two wheat corns in the midst of the ear, and twenty pence to make an ounce, and twelve ounces one pound, and eight pounds do make a gallon of wine; and eight gallons of wine do make a London bushel, which is the eighth part of a quarter." These weights and measures were again precisely specified and confirmed in the reign of Henry VII., in the year 1496. The first statute that directs the use of the *avoirdupois* weight is the twenty-fourth of Henry VIII., wherein it is directed to be used for weighing butchers' meat in the market, though it has been used for weighing all kinds of coarse bulky articles of ordinary consumption. This pound contains 7000 troy grains; while the troy pound contains only 5760 grains. The difference between the troy and avoirdupois weight may be more exactly determined by reference to the annexed tables.

*Troy Weight.*

		Cubic inches of water.
$\frac{1}{1253458}$ of a cubic inch of water	= 1 grain	= .0039610571428
24 grains	= 1 pennyweight	= .0950653714235
20 pennyweights	= 1 ounce	= 1.901307428571
12 ounces	= 1 pound	= 22.815689142857

A cubic inch of distilled water, at the maximum density weighs 253 troy grains.

*Avoirdupois Weight.*

		Cubic inches of water.
27 $\frac{11}{32}$ grains	= 1 dram	= .10831015625
16 drams	= 1 ounce	= 1.7329625
16 ounces	= 1 pound	= 27.7274
28 pounds	= 1 quarter cwt.	= 776.3672
4 quarters	= 1 cwt.	= 3105.4688
20 cwt.	= 1 ton	= 6210.93760
175 troy pounds	= 144 avoirdupois pounds.	
175 troy ounces	= 192 avoirdupois ounces.	

By an act of parliament made in the fifth year of his late majesty George IV., it was enacted that there should be adopted on, and after the 1st of May, 1825, throughout the United Kingdom, a uniformity of weights and measures. The following is, according to Mr. Gutteridge, the rationale of the improvement introduced by this act. "Take a pendulum which vibrates seconds in London, on a level with the sea, in a vacuum; divide all that part thereof which lies between the axis of suspension, and the centre of oscillation, into 391393 equal parts; then will ten thousand of those be an imperial inch, twelve whereof make a foot, and thirty-six a yard. Take a cube of one such inch of distilled water, at 62° of temperature, by Fahrenheit's thermometer; let this be weighed by any weight, and let such weight be divided into 252458 equal parts, then will one thousand of such parts be a troy grain; and 7000 of these grains will be a pound avoirdupois, the operation having been performed in air. Ten pounds, such as those mentioned of distilled water, at 62° of temperature, will be a gallon, which gallon will contain 277 cubic inches, and 274 one thousandth parts of another cubic inch." By the authority aforesaid it is also enacted, "that a cubic inch of distilled water in a vacuum, weighed by brass weights, also in a vacuum, at the temperature of 62° of Fahrenheit's thermometer, shall weigh 252.724 grains;" and, "that the standard measure of capacity, as well for liquids as for dry goods not measured with heaped measure, shall be the gallon containing ten pounds avoirdupois weight, of distilled water weighed in air, at the temperature of 62°, the barometer being thirty inches." This gallon, therefore, containing 277.274 cubic inches, is about one-fifth greater than the old wine gallon, one thirty-second greater than the old dry gallon, and one-sixtieth less than the old beer gallon. Eight such imperial gallons to be a bushel, eight such bushels to be a quarter of

corn or other dry goods; the quart to be one-fourth, and the pint one-eighth of the above gallon, and none of these measures to be heaped up. The said standard bushel, which will therefore contain eighty pounds, avoirdupois, of water, is required to be a cylinder with a plain and even bottom, the extreme diameter of which is nineteen and a half inches. No other bushel than this is to be employed for coals, or other commodities usually sold by heaped measure.

**WELDING.** A term applied to a peculiar process of uniting pieces of iron together by heat and pressure. There are only two metals susceptible of this process, iron and platina. They are brought to a white heat in a furnace, and joined by quick and forcible hammering, by which they unite as one piece, when executed by skilful workmen.

**WELD, or WOALD.** A plant cultivated in many parts of this kingdom, for its yellow colouring matter. Two sorts of weld are distinguished, the bastard or wild, which grows naturally in the fields; and the cultivated, the stalks of which are smaller and not so high. The latter is preferred for dyeing, abounding more in colouring matter. When the plant has arrived at maturity the stalks are pulled, made into bundles and dried, in which state it is used. To give a permanent yellow to wool by weld, mordants become necessary; but when prepared with alum and tartar, it takes a very durable and fine yellow.

**WHALE-FISHERY.** This subject being so intimately connected with our manufactures, we insert the following account of it. In the Greenland fishery by Europeans, every ship is provided with six boats, to each of which belong six men, for rowing the boat, and a harpooner, whose business is to strike the whale with his harpoon. Two of these boats are kept constantly on the watch, at some distance from the ship, fastened to pieces of ice, and are released by others every four hours. As soon as a whale is perceived, both the boats set out in pursuit of it, and if either of them can come up before the whale finally descends,—which is known by his throwing up his tail,—the harpooner discharges his harpoon at him. As soon as the whale is struck, the men set up one of their oars in the middle of the boat, as a signal to those in the ship; upon which all the others set out to the assistance of the first. The whale, finding himself wounded, swims off with prodigious velocity. Sometimes he descends perpendicularly, and sometimes he goes off horizontally, at a small depth below the surface. The rope which is fastened to the harpoon is about 200 fathoms long, and properly coiled up, that it may be freely given out as there is a demand for it. At first, the velocity with which this rope runs over the side of the boat is so great, that it is wetted to prevent its taking fire: but in a short time the strength of the whale begins to fail, and the fishermen, instead of letting out more rope, strive as much as possible to pull back what has been given already, though they always find themselves necessitated to yield at last to the efforts of the animal, to prevent his sinking their boat. If he runs out the 200 fathoms of line contained in one boat, that belonging to another is immediately fastened to the end of the first, and so on; and there have been instances where all the rope belonging to the six boats has been necessary, though half that quantity is seldom required. The whale cannot stay long below water, but again comes up to blow; and, being now much fatigued and wounded, stays longer above water than usual. This gives another boat time to come up with him, and he is again struck with a harpoon. He again descends, but with less force than before; and when he comes up again, is generally incapable of descending, but suffers himself to be wounded and killed with long lances which the men are provided with for that purpose. He is known to be near death when he spouts up the water, deeply tinged with blood. The whale, when dead, is lashed alongside the ship. They then lay it on one side, and put two ropes, one at the head and the other at the place of the tail, which, together with the fins, is struck off, as soon as he is taken, to keep those extremities above water. On the off-side of the whale are two boats, to receive the pieces of fat, utensils, and men, that might otherwise fall into the water on that side. These precautions being taken, three men with irons at their feet, to prevent slipping, get on the whale, and begin to cut out pieces of about three feet thick and eight long, which are hauled up at the capstan or windlass. When the fat is all got off,

they cut off the whalebone of the upper jaw with an axe. Before they cut, they are all lashed to keep them firm ; which also facilitates the cutting, and prevents them from falling into the sea ; when on board, five or six of them are bundled together and properly stowed, and after all is got off, the carcase is turned adrift, and devoured by the white bears, who are very fond of it. In proportion as the large pieces of fat are cut off, the rest of the crew are employed in slicing them smaller, and picking out all the lean. When this is prepared, they stow it in under the deck, where it lies till the fat of all the whales taken during the fishery is on board ; then cutting it still smaller, they put it up in tubs in the hold. At the end of the season they return home, where the fat is boiled and pressed, to give out the oil. (See a press for this purpose, under the Article OIL.)

Among the Kurile islands, which are situated near the southern extremity of the peninsula of Kamtschatka, the whales are most abundant about the beginning of autumn. At that time the inhabitants embark in their canoes, and search for them in places where they generally find them asleep on the surface of the water. When they are so fortunate as to find one in this situation, they approach with the least possible noise, and when they have come within the proper distance, they pierce him with poisoned arrows ; and although these wounds seem extremely slight, they are said in a short time to occasion great pain. The whale thus wounded, moves about furiously, blows with great violence, and soon dies.

When the whale returns to Greenland, the fishermen equip themselves with sharp knives, harpoons, spears, and arrows, with a number of large skins of the sea-dog, inflated. Thus equipped, they launch their canoes. The harpoon which they usually employ is pointed with bone, or a sharp stone ; some, indeed, have harpoons of iron, which they procure from the Danes, by barter for the oil or fat of the whale. The scarcity of iron and wood makes these articles extremely valuable to Greenlanders, and has excited their ingenuity, to avoid the risk of losing them. For this purpose an inflated bladder of dog's skin is attached to the harpoon ; so that, in case it should not reach the whale, when they attempt to strike, it may float on the water and be recovered. They approach them with astonishing boldness, and endeavour to fix, by means of their harpoons, which they throw at his body, some of the skins inflated with air ; for, notwithstanding the enormous bulk of this animal, two or three of these skins, by the resistance which they make to the water, on account of their diminished specific gravity, greatly impede his attempts at plunging into the deep. Having by this means succeeded in arresting his progress, they approach nearer, and with their lances pierce his body, till he becomes languid and at last dies. The fishermen then plunge into the sea with their skin jackets filled with air, and swim to their prize ; and, floating on the surface of the water, they cut off with their knives, from every part of the whale, the fat or blubber, which is thrown into the canoes ; and notwithstanding the rudeness of their instruments, their dexterity is such, that they can extract from the mouth the greatest part of the whalebone.

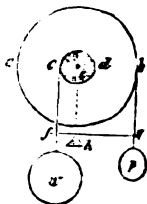
The boldest and most astonishing mode of fishing the whale, is that which is practised by the Indians on the coast of Florida. When the whale appears, they fasten to their bodies two pieces of wood and a mallet ; and these instruments, with their canoe, form the whole of their fishing equipage. When they approach the whale they throw themselves into the water, and, swimming directly towards him, they have the address to get on his neck, taking care to avoid the stroke of his fin or tail. When the whale first spouts, the Indian introduces one of the pieces of wood into the opening of one of the blow-holes, and drives it home with the mallet. The whale thus attacked, instantly plunges, and carries the Indian with him, who keeps fast hold of the animal ; the whale, which has now only one blow-hole, soon returns to the surface of the water to respire ; and if the Indian succeeds in fixing the other piece of wood into the second blow-hole, the whale again descends to the bottom, but a moment after reappears on the surface, where he remains motionless, and immediately expires, by the interruption of the function of respiration.

**WHARF.** A firm landing-place, built beside the water for the convenience of loading or unloading ships, barges, or other vessels ; and therefore usually



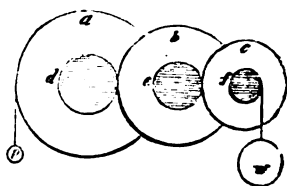
furnished with cranes and various appendages, according to the nature and extent of the business to be performed.

**WHEEL and AXLE.** A modification of the lever, by means of which a weight may be raised to a considerable height. A slight attention to the nature of the lever will show that the extent of its influence in space is very small, depending upon the length of that arm to which the weight is attached; and as this arm becomes shorter in proportion to the increase of power obtained, so the height to which a body may be raised, speedily attains its limit. In the wheel and axle, no limit of this kind exists. Let  $a b$ , in the annexed cut, represent the diameter of the wheel, and  $c d$  that of the axle; then, if a power  $p$  be connected by means of a rope to the wheel, and a weight  $w$  to the axle, these two, when in equilibrium, will be to each other as  $c d$  to  $a b$ . That is, the power is to the weight as the diameter of the axle to the diameter of the wheel; or, since the diameter of a circle is double its radius; as, the radius of the axle to the radius of the wheel. If a line  $f h g$  be drawn, connecting the parallel cords, and a perpendicular  $e h$  be let fall on it, it will be divided in the same ratio as the diameters or radii



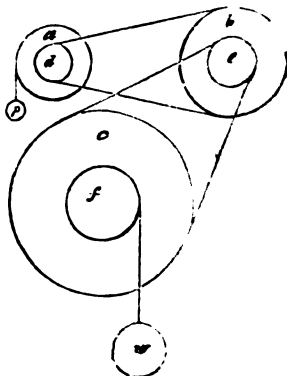
of the wheel and axle; and hence its relation to the lever becomes manifest. It will be immediately seen that the power is to the weight, as  $f h$  to  $h g$ ; that is, as the radius of the axle to the radius of the wheel. The velocity with which the power and weight will move, is, as in the other simple machines, inversely as the power gained. If the diameter of the wheel be 20 inches, and that of the

axle 4 inches, the power obtained will be  $\frac{20}{4} = 5$  times; or a power of one pound will balance a weight of five pounds; but the velocity with which the weight moves, is five times less than that of the power. The windlass by which water is drawn from wells, and the capstan used to raise the anchor on ship-board, are illustrations of the utility of this simple machine; but the most extensive employment of the wheel and axle is in combination, in which, under



the name of wheel and pinion, it enters largely into the construction of the most complicated machinery. In the arrangement of a number of wheels and pinions for the purpose of gaining power, or velocity, each pinion is connected with the following wheel, and the power or weight is attached to the last pinion.

Thus, in the foregoing representation  $a b$  and  $c$  are three wheels;  $d e f$ , three axles or pinions, as it may be; the power  $p$  puts  $a$  into motion, the axle of which turns  $b$ , whose axle again influences  $c$ , on the axle of which the resistance is applied. The proportion between  $p$  and  $w$  in this and similar cases, will be found by multiplying together the diameters of the axles, and the diameters of the wheels. If the diameters of the wheels be 14, 9 and 7, and the axles be 3, 3 and 2, the power obtained will be  $\frac{14 \times 9 \times 7}{3 \times 3 \times 2} = 49$ , and as a consequence,



the velocity of  $p$  must be 49 times greater than that of  $w$ . When wheels and pinions act upon each other as in watches and other machines, a number of teeth are cut in the circumference of each, in nearly the same proportion as the radii of the wheel and pinion. Sometimes, especially in heavy machinery, they are connected by bands, as in the annexed cut; but the calculated power is still the same at whatever angle they may be placed to each other, since the bands always act on that part of the wheel which

is perpendicular to their own direction. In calculating the power of this machine, allowance must be made for the friction on the pivots, the weight and stiffness of the rope, and for the increased magnitude which a large rope gives to the wheel or axle.

**WHEEL.** A circular frame, or solid disc, made of wood or metal, and turning upon an axis. There are a variety of kinds, but we shall in this place direct our attention to carriage wheels, to which the foregoing definition will best apply. The ordinary carriage wheel consists of three principal parts; namely, the nave, hub, or centre; the spokes or radii, which connect the centre to the periphery or ring. The ring is sometimes made of one entire length, bent into the circular form; but by far the most usual plan is to construct the ring of a series of curved pieces, correctly jointed endways, so as to complete the entire circle. After the ring is thus prepared, and every joint corrected and smoothed whilst placed in its true circle, the joints are bored, and an oaken dowel or pin driven into the perforations. The manufacture of the spokes consists in chopping them first to nearly their shape, and then finishing their figure by spoke-shaves; afterwards they are all gauged to an exact length, their shoulders and tenons made, the tenons that are to enter the stock being square, and those for the felloes round; and all the tenons are made a little larger towards their shoulders than at their other ends, in order that they may fit very tightly when driven up into their mortises. The tenons in the nave depend wholly for their firmness there, to accurate workmanship; but the tenons in the felloes go through their thickness, and are then wedged up on the outside. The strength of a wheel depends greatly on the attention paid to the arrangement and framing of the spokes; in common wheels they are framed equally all round the thickest part of the nave, the tenons of the spokes being so beveled as to stand, with reference to the horizontal position of the nave, about three inches out of the perpendicular: this is done to produce what is called the *dishing* of the wheel. But for obtaining increased strength, the spokes of wheels, (as in those of the mail coaches,) are framed so that every other spoke shall stand perpendicular to the nave. Hence the mortises are made in two parallel lines around the nave, the other ends of the spokes entering the felloes in a single line; therefore, viewed edgewise, the position of the spokes represents two sides of an isosceles triangle, of which the axis forms the base line, (an arrangement which the uninformed will clearly understand, upon reference to the perspective figure of Jones's patent suspension wheel, given further on in this article;) this confers great stability to the wheel, at a trifling addition of cost of workmanship.

The blocks which form the naves of wheels are furnished to the wheelwright, of the size required. The wood preferred for this purpose is elm. To produce their round conical form they are turned in a lathe, with neat mouldings upon the surface. The nave is now ready to have its mortises cut; which is a work of considerable art, especially when executed in the rapid and correct manner in which they usually are, by practised workmen. In this work the wheelwright uses a very simple and efficient tool, that is peculiar to his craft; it is called a *bux*, and is employed to cut out the angles of his mortises square and clean; it is a sort of double chisel, or that in which the straight edges of two common chisels are united at right angles; and it cuts out the corners, as may be supposed, very expeditiously, and so exactly that the square tenon of the spoke bites very firmly in every part. The workman fits each spoke successively, and puts a mark upon it. When they are all fitted, he begins to put the whole wheel together, fitting all the spokes to the nave first, and then adding the felloes. In this state the wheel is put to season; that is, exposing it to a current of air for a week or two, or, as in some manufactories, placing it in a kiln for a few hours, heated to about 140° Fahrenheit. When seasoned, the whole of the wheel is examined, to ascertain if all its parts are still adapted to make solid and close joints in every part; and if found so, they are all secured and fixed, by driving up all the spokes firmly into the nave, and then putting on the felloes, and driving them down firmly upon the shoulders of the spokes; and the ends of the tenons, which come through the felloes, are then secured by

wedges driven into their middles. This done, the wheelwright "cleans off;" that is, finishes the wood-work, by his planes, shaves, fish-skin, and glass-paper. The next operation is to put on the iron tire. The tire is made of flat bar iron, and of breadth and thickness proportioned to the wheel. When the tire consists of separate pieces or streaks, the bars are cut to the same length as the felloes, and curved to the radius of the wheel, and have suitable holes punched through them, to receive very stout nails, by which they are secured to the wooden ring of the wheel; and the iron tire is so placed over the felloes, as to meet in the middle of each felloe, and thus secure more effectually the joints of the latter; the tire nails pass quite through the felloes, and are rivetted on the inside of the ring, upon bars or washers, which materially strengthens the fabric. Further to bind and compress the parts of the wheel together, the tire is put and nailed on to the wheel in a red-hot state; which burns and presses down all bumps and inequalities of the surface, and produces great solidity of structure. The best kinds of wheels,—those used for coaches and other light vehicles,—have usually their tires of one single piece or ring ready formed, which is expanded by being made hot in a circular fire, and in this state put upon the wooden periphery of the wheel, when, by its shrinking as it cools, it draws all the parts of the wheel together with irresistible force.

Many years ago a patent was obtained for making the whole wooden periphery of one entire piece, and this process is still extensively practised for the wheels of light carriages. Straight grained ash is selected and boiled or steamed, until it becomes very flexible, when it is bent on a cylinder, and fastened together whilst in its circular form.

Having now described the several parts of an ordinary carriage wheel, excepting the axletree, and box, we refer the reader for information on those points to their initial letter (also to the articles CARRIAGE and RAILWAY,) in this work; and proceed to the description of some modern improvements.

The purposes to which iron, whether cast or malleable, may be usefully applied, are daily becoming more numerous; its great durability, and the facility with which it may now (by the aid of our varied and powerful machinery,) be wrought to any desired form, point it out as peculiarly adapted for the wheels of

Fig. 1.

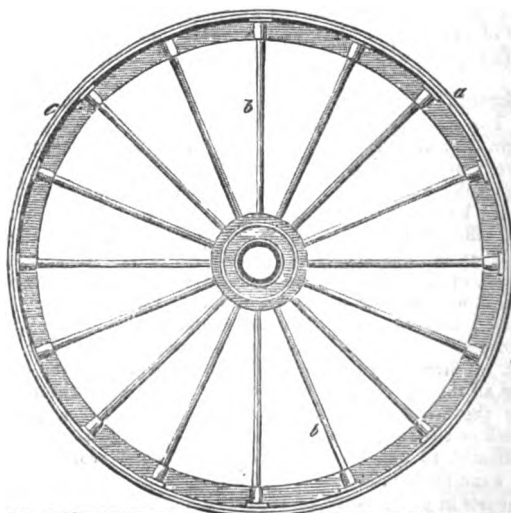
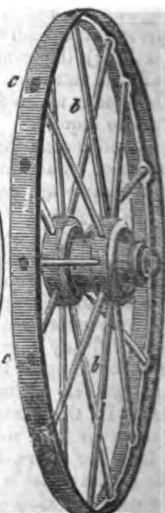
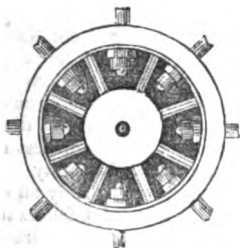
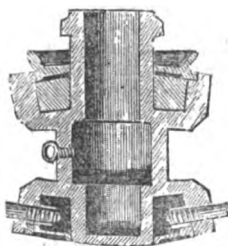


Fig. 2.



carriages. Accordingly, various attempts have been made at different times to construct wheels wholly of this material, but certain difficulties have opposed

their general introduction; and their use may be said to have been confined to rail-roads, until the invention of Mr. Theodore Jones, who took out a patent for an "iron suspension-wheel," about eight years ago, and a large manufactory of them has been established at Vauxhall, from whence are constantly sent out considerable numbers, attached to the carts and waggons of the metropolis, as our London readers will testify, upon recognizing their representation in the above engravings, of which *Fig. 1* is an elevation, and *Fig. 2* a perspective view of a cart or light waggon-wheel, the principle of their construction not differing according to

*Fig. 3.**Fig. 4.*

their application, but only in the proportions of their parts. *Fig. 3* represents a nave, shown on a larger scale, with the front shield or cap removed to show the construction. It contains eight feathers or divisions, dividing it into eight compartments. *Fig. 4* is a section of the nave, with the front and back shields in their places.

At *a* is a strong rim of cast or wrought iron, with a rib on the inside to give additional strength. Sixteen conical holes are made through the rim at equal distances; *b b b* are wrought iron rods, with conical heads *c c c* fitting into the holes of the rim, and have screws cut at their other ends. These rods, through the holes in the rims, and corresponding holes in the nave, where the screwed ends are secured by nuts, are plainly shown in the sections. The shields are then placed over the nave, and by the pressure of their flat surfaces against the sides of the nuts, they are prevented from becoming unscrewed. A hoop or iron tire is fixed on the outer circumference which is to be replaced when it becomes worn by use.

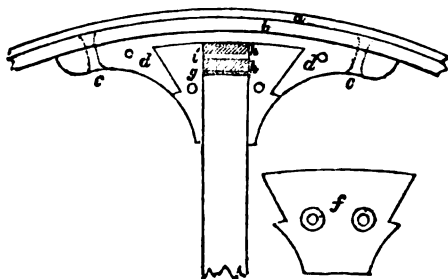
The description we have thus given is derived from the specification of the patentee; but since the enrolment of that document, the experience of the inventor, derived from great practice, has enabled him to introduce many subordinate improvements, amongst which we may mention, the making the rim, with the projecting rib underneath, of one single solid piece of wrought iron, obviating the use of any cast iron, and dispensing entirely with the necessity of any tire ring. This is a very important improvement, as it was discovered that the battering which the tire rings received against the stone pavement, had the effect of expanding them, and consequently of causing them to separate or become loose upon the iron periphery underneath; and when the latter was of cast-iron, fractures were sometimes made by the concussions of the road. Now, as there is only one ring, and that of wrought iron, the expansion that it may undergo by severe battering, has only a tendency to increase the tension of the rods, and the stability of the whole.

It will be observed in the drawings that the wheels are not conical, nor dished as usual, but cylindrical; which, in the opinion generally of those who have been enabled to examine the subject, unprejudiced, causes them to move with less resistance on their peripheries, or *run lighter*, as the phrase is; and they

will, from the same cause, prove less destructive to the road. This latter property may be considered as established, as an act of parliament empower the trustees of the roads to reduce the tolls on the cylindrical wheels, to two thirds of the sum paid for conical wheels of similar width. The reason of these patent wheels being called *suspension* wheels, is that the nave may be considered as constantly suspended by the rods above it to an inflexible arch; instead of, as in the common wooden wheels, resting with its load upon the particular spoke that may happen to be underneath it; and thus it is argued the cohesive strength of the metal is made available, which is undoubtedly the most advantageous mode of employing malleable iron, (it having been proved by repeated experiments, that a rod of wrought iron, an inch in diameter, is capable of sustaining a pull of twenty-seven tons weight;) and the weight of the load upon the axles being thus suspended to the upper side of the wheel, the lower rods have to sustain but a small portion of the pressure, and are not liable to be broken by sudden concussions or jolts. From the superior tenacity of the metal over wood, the mass of material is so considerably reduced, as to render a suspension wheel not heavier than a wooden one, which is applicable to the same kind of carriage or strain; and from the circumstance of this diminution of material they have a more elegant and light appearance, require less draught, whilst they unquestionably possess increased strength and durability.

However excellent may be the workmanship, or however firmly an ordinary wooden wheel may be put together in the first instance, the wooden felloes that form the periphery, being constantly exposed to the effects of wet and dry, are continually expanding and contracting; consequently the joint or connexions between the ends of the spokes and the felloes, and the former, either become loose, or split the felloes; when this takes place, the several parts of the wheel yield by little and little to the strain of the load, or the effects of concussions, and the whole wheel becomes dislocated. As a remedy to this defect, Mr. Wm. Howard, the iron-master of Rotherhithe, has recently proposed some new arrangements of a precisely opposite character to Mr. Jones's; which we proceed to describe.

Mr. Howard's invention has no reference whatever to the nave of the wheel but is confined to an improved mode of combining a wheel at its periphery. He employs, as shown in the subjoined figure, representative of a small portion of a wheel, an iron ring *a*, as the outside tire; inside of this tire he has another ring of iron, *b*, which stands as a substitute for the ordinary felloes; and to this, which we will call for distinction the felloe-ring, he fastens by red-hot rivets *c c*, a "spoke-shoe" *d d*, made of the shape represented, of cast-iron, and containing a central cavity or socket, for the insertion of the end of a spoke *e*; of course there are as many spoke-shoes as spokes, which are arranged equidistantly around the inside of the felloe-ring; when these have been all firmly fixed in



the manner of that shown, and the spokes have been all duly fitted into the nave and driven home, and the outer ends of all the spokes have been accurately gauged, and duly fitted to the sockets of the shoes, they are put or forced into the same sideways, as seen at *e*; this operation is performed in such a manner as to leave a space of about half an inch between the ends of the spokes and the

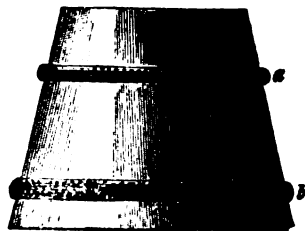
ends of the sockets, for the purpose of wedging them up firmly. This is effected in the following manner:—Against the squared end of each spoke is laid a thin piece of plate-iron *g*, of the same sectional area; then is driven a slightly tapered long oaken wedge *h h*, the foremost end passing through a hole cast in the shoe on the opposite side: and when the cavity is thus closely filled, the projecting pieces are cut off, and a sharp iron wedge *i*, is then driven into the middle of the oaken wedge, so as to render the force of contact as great as possible; a plate of wrought iron, *f*, is then put into the cavity represented over *e h i*, and riveted to the shoe by long red-hot rivets passing through the whole. All the shoes and spokes being thus fitted, the tire ring is put over the whole in a red-hot state, which, shrinking as it cools, draws the whole together in a manner that gives it extraordinary solidity.

It will be observed that the principle of construction of Mr. Howard's wheels is the same as that of the common kind, in which dependence is placed entirely upon the stability of the outer ring for its cohesion; but it is a more finished and masterly production, is constructed of more tenacious materials, and is well calculated to obviate the leading defects before mentioned of the former. The advocates for Mr. Jones's wheel object to Mr. Howard's, on the ground of its not being on the tension principle. On this point we would observe, that the spokes undoubtedly are not, but that it may be fairly contended that the periphery is, as this must be torn asunder by a longitudinal pull, in order to destroy the cohesion of the wheel; and the felloe-ring alone, (which never wears,) is made of adequate strength to bear the whole strain, without any of the additional support it derives from the tire-ring; the utmost confidence may therefore be placed in the great strength and durability of Mr. Howard's wheels, however excellent may be the principle of the former invention.

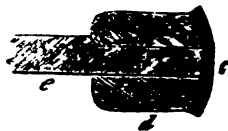
A patent was recently taken out for a very strong metallic wheel, by the Messrs. Forrester, of Liverpool, consisting of a skeleton of malleable iron, imbedded or surrounded with cast iron. Such wheels are, however, necessarily very heavy, and less suited to the common road than to RAILWAYS.—For a description of them, see the latter article.

We shall, however, advert in this place to another patent,—not on account of any novelty it may be found to contain, but for the twofold purpose of elucidating a process that we had imagined was commonly practised by iron-masters and tire-smiths, and of affording us an opportunity of noticing the erroneous principle upon which wheels in general are constructed.

The specification of Mr. John Meaden, of Southampton's patent, (enrolled June 1828,) states his object to be the construction of the tire or hoops of iron, which surround carriage wheels, *concave* on the inner surface, next to the felloes, and *convex* on the external surface; the objects of which are to fix the tire more securely to the wheel, and to reduce the friction produced between the periphery of the wheel and the road. The specification proceeds to describe very minutely the process of making tires,—a process which we doubt not our readers of the before-mentioned callings will recognise as a “modern antique.” A common flat wrought-iron bar, of the proper width and length, is to be passed between a pair of rollers, one of which has a concave groove, and the other a corresponding convex projection, so as to compress and bend the intervening bar into the required form. The bar thus formed is next bent round into a hoop of the required size, with the concave side inwards, and then the ends are welded together. To give the hoop the desired conical figure, or “dishing,” it is placed over a large cast-iron mandril, like that represented in the annexed figure, where it is hammered until it takes the required form. The letters *a* and *b* indicate hoops of different sizes. To fix this hoop to the wheel, it is heated in a furnace of a circular form, so that the fire may act uniformly on every part. In a large wheel, this process of heating the hoop causes it to expand about one inch in circumference, and it is thereby made large enough to slip over the wooden



wheel, previously prepared, of greater dimensions than the interior circle of the iron hoop, in the cold state. Whilst the iron hoop is being heated, the wooden wheel is clamped to a flat circular plate, which is fixed to a central axis, to enable it to revolve; and this axis is fixed upon an horizontal bar, by which the wheel and iron plate to which it is clamped may be turned in either a vertical or horizontal direction. Underneath the circular plate is a semicircular well or cistern, containing cold water, into which the wheel is immersed and turned round as soon as the hoop is put on it. This application of cold to the hot expanded hoop causes it to contract with irresistible force, pressing the spokes into the felloes and nave, and binding all the parts together. The annexed little figure exhibits a section of the *new* patent tire, as applied to the felloe *d*; *e* representing the end of a spoke. A curved tire like the foregoing was made many years prior to Mr. Meaden's patent, but by simpler and cheaper means,—it being rolled directly from the bloom into curved bars; and we think we remember seeing them on the mail coaches more than twenty years ago. The curve on the interior side of the tire is of unquestionable advantage, in causing it to hold more securely on the felloes,—as must be evident from the preceding figure; but the external curvature of the tire is, in our opinion, of very doubtful utility. The rounding of the extreme edges of a flat-bearing wheel may prevent dirt being hitched up and carried round with the wheel; but even that much being removed, reduces to the same extent the resistance of the ground to the wheel sinking into it; and if the whole bearing surface be rounded, it must evidently penetrate deeper into the ground, and in so doing force the materials of the road sideways. Nevertheless, tire of this construction is, we believe, still employed in our mail coaches. But however injurious to the roads may be tire of this kind, the practice of giving a conical form to the rims of carriage wheels is infinitely more destructive. This form has an evident tendency to move in a different direction to the line of draught; and the power which is required to keep it in a straight line is so much power wasted in twisting the materials of the road out of settings, and grinding them to powder.



The cylinder (as Mr. Cumming justly observes) having all its parts of equal diameter, will, in rolling on its rim, have an equal velocity at every part of its circumference, and necessarily advance in a straight line. And as all the parts of the rim have an equal velocity, none can have a tendency to drag forward or impede the progress of the others; they all advance with one consent, without the rubbing of any part on the surface on which they roll. As there is no rubbing there can be no friction, and consequently a cylinder perfectly round, hard, and smooth, forms the least possible resistance, however great its weight or the pressure on its rim. It therefore follows, that all the power that is employed in drawing forward a cylindrical body in a straight line on a compressible substance, is ultimately applied in compressing smooth and levelling the substance on which it rolls. The rolling of a cylindrical body, therefore, can have no tendency to alter the relative situation or parts of materials on which it passes, nor any how to derange them, but by a progressive dead pressure to consolidate, level, and smoothe them. If a cylinder be cut transversely into several lengths, each part will possess all the above properties; and if the rim of a carriage wheel be made exactly of the same shape, it must necessarily have the same tendencies. When wheels with cylindrical rims are connected by an axis, the tendency of each being to advance in a direct line, they proceed in this connected state with the same harmony and unity of consent that exist in the parts of the same cylinder; but, as conical rims have been universally preferred for a series of years, it is natural to suppose that there were obvious reasons for such preference. The cone diminishing gradually from its base to its point, the velocity of every part of its circumference in rolling on an even plane, will be diminished as the diameter; and at the very point where there is no visible diameter, it will have no perceptible motion; but if the cone be made to advance in a straight line, the natural velocity of its several parts will not be as the spaces, therefore a rubbing and friction will take place at its circumference, from the different

velocities of its parts, which must render the draught heavier. In rolling on paved streets nothing can be conceived more calculated for their destruction than the conical rim of a broad wheel. See CARRIAGES, AXLETREE, &c.

For TEETHED WHEELS employed in driving machinery, see that article.

WHERRY. A small, shallow, light boat, made very sharp both at the head and the stern, and adapted for fast rowing and sailing, especially in tide rivers.

WHIRLING-TABLE. An instrument for illustrating the nature of the centripetal and centrifugal forces. The disposition which bodies have to fly off from the axis round which they revolve, may be beautifully exhibited, by employing a small bucket filled with water, and attaching it to the hand by a flexible cord, it may be whirled round without destroying the equilibrium of the fluid, or causing any portion of it to be spilled. Precisely in the same way are the bodies which revolve round the sun, kept from falling into that luminary by the centrifugal force which is generated. Now the whirling-table is employed to exhibit the amount of this force, and, by a combination of weights and pulleys, a variety of bodies are made to revolve with different degrees of speed. The apparatus usually consists of a frame furnished with a large wheel, round which a band passes, and gives motion to two smaller ones. On one of these a rod is attached for balls to slide, and on the other a flat table of mahogany; and these may be put into motion with different degrees of speed. The whole apparatus is exceedingly valuable to the teacher of astronomy.

WHIRLPOOL. An eddy, vortex, or gulf, where the water is continually turning round. Those in rivers are very common, from various accidents, and are usually very trivial, and of little consequence. In the sea they are more rare, but more dangerous. Sibbald has related the effects of a very remarkable marine whirlpool among the Orcades, "which would prove very dangerous to strangers, though it is of no consequence to the people who are used to it. This is not fixed to any particular place, but appears in various parts of the limits of the sea among these islands. Wherever it appears, it is very furious; the boats, &c., would inevitably be drawn in, and be destroyed by it; but the people who navigate them, are prepared for it, and always carry an empty vessel, a log of wood, or large bundle of straw, or some such thing, in the boat with them. As soon as they perceive the whirlpool, they toss this within its vortex, keeping themselves out; this substance, whatever it be, is immediately received into the centre, and carried under water; and, as soon as this is done, the surface of the place, where the whirlpool was, becomes smooth, and they row over it with safety; and in about an hour, they see the vortex begin again in some other place, usually at about a mile distant from the first."

WHIRLWIND. This meteorological phenomenon arises from the convergence of winds from all parts to one point on account of an extraordinary rarefaction of the air at that point. The currents acquire by their conflict at the place of meeting, and the velocity with which the rarefied air rushes upwards, a centrifugal force, which causes them to recede from the axis of rotation. When the centrifugal force thus acquired becomes equal to the pressure of the atmosphere, a space approaching almost to a vacuum surrounds the axis or centre of motion, and as the whirl, by the action of the most prevailing wind, receives a progressive motion, it is obvious that the pressure of the atmosphere will be removed from every object passed over by the base of the vacuum; consequently destruction may be expected to mark its course. Partly by the removal of the atmospheric pressure, and partly by the whirling of the air surrounding the vacuum, loose bodies, a hay-stack, for example, will be raised with irresistible impetuosity, and dissipated at a great height.

WHISKEY. This species of ardent spirit is much used in this country as well as in Ireland. It varies considerably in the mode of preparation as well as in its strength and comparative value. One of the modes of procuring it is stated in Gray's *Operative Chemist* to consist in mixing 3840 gallons of rye or barley ground very fine, and 1280 gallons of coarse ground pale malt, and making it into a mash, with 8500 gallons of water, heated to 170° Fahr. There is then drawn off 1020 gallons of this wort, and a large quantity of yeast is

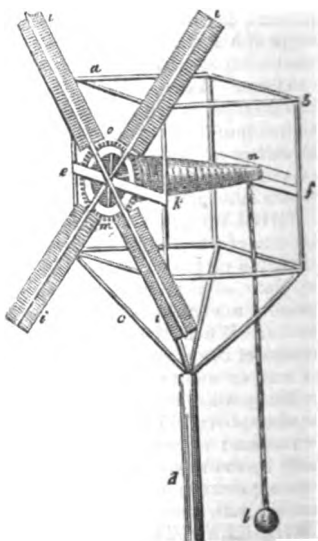


added to it; and when the remaining wort is cooled to 55° Fahr. eighty gallons of malt are mashed with another portion of 1020 gallons of hot water, and this, being drawn off, is mixed with the first wort, and the yeasted wort is also added. This wash should have the specific gravity from 1.084 to 1.110. In the course of ten or twelve days, the specific gravity gradually diminishes till it becomes only 1.002, when the yeast head falls quite flat; the wash has a vinous smell and taste, and is fit for the still. It is calculated that every sixty-four gallons of meal and malt ought to produce eighteen gallons of spirit, so much stronger than proof spirit that ten gallons will make eleven gallons proof.

In general, one-third of the wash is drawn over at the first stilling, and the product is called low wines, the specific gravity being about 0.975. On redistilling the low wines, a milky, fiery tasted spirit comes over at first; when the running turns clear, the spirit that has come over is returned into the still. The distillation being continued, the clean spirit comes over; and when the running gets below a certain specific gravity, the remaining spirit which comes over, until it ceases to be inflammable, is kept apart by the name of faints, and is mixed with the next parcel of low wines that are distilled. The proportion of malt to the raw grain is sometimes diminished much below that stated, even as low as only one-tenth of the raw grain. If the wort is not sufficiently heavy, its specific gravity is brought up, by adding a strong infusion of ground malt, or barley and malt. The fermentation is generally carried on in open pits, and hurried as much as possible; but of late some distillers, considering that the carbonic acid gas carried off much of the spirit, have covered the pits with a flooring, having a trap with a water joint, to prevent the loss of the spirit; this retards the fermentation, but the augmentation of the produce, although slight, is judged fully equivalent to the loss of time.

**WINCH.** The bent, or crank-handle, by which the axes of machines are turned.

**WIND.** Air put in motion by some physical cause, so as to become a current or stream. Winds are denominated according to the points from which they blow; see COMPASS. A variety of machines have been invented at different times for ascertaining the strength or velocity of the wind; the annexed cut represents one which possesses the advantages of simplicity of construction, and of being unerrin in its indications. It is thus formed:—A square open frame of wood or iron, *abc*, is supported by the shaft *d*; two cross pieces are fixed at *e*, *f*, carrying an horizontal axis, which is moved by the action of the wind upon four sails, *iiii*, fixed to one end of the axis, and disposed to be influenced by the wind in the usual manner. Upon this axis is also fixed a conical barrel of wood, on the smaller end of which, *m*, is attached a line with a weight, *l*, appended to it. The wind now acting upon the sails, causes the barrel to revolve, and the line to be wound round its superficies. To prevent any retrograde motion, a ratchet wheel *o*, is fixed to the base or larger end of the cone *m*, having a clicker falling into its notches as it revolves. It is evident that the force of the weight will continually increase as the line advances towards the base of the cone, by the power being applied at a greater distance from the axis or fulcrum; consequently the variable force of the wind may be readily ascertained, by fixing the line at the smallest end, and marking the barrel with spiral lines, as taken up by the coiling of



the rope round its superficies ; placing, also, between the line so drawn, numerical signs to denote the force of the wind ; which might be calculated with tolerable precision, according to the known principles of the lever. The diameter of the base of the cone should be such, in comparison with the smaller end, that the very strongest wind should have scarcely sufficient power to bring it on to the end of it.

The different velocities, forces, and corresponding popular appellations of winds are given in the following table, derived from the experiments of the late celebrated engineer, John Smeaton ; and detailed in the *Philosophical Transactions*

Velocity.		Perp. Force on one square foot in lbs. avoirdupois.	Appellations.
Per hour Miles.	Per Second Feet.		
1	1.47	.005	Scarcely perceptible.
2	2.93	.020	} Perceptible.
3	4.40	.044	
4	5.87	.079	} Gentle breeze.
5	7.33	.123	
10	14.67	.492	} Pleasant brisk gale.
15	22.00	1.107	
20	29.34	1.968	} Very brisk gale.
25	36.67	3.075	
30	44.01	4.429	} High winds.
35	51.34	6.027	
40	58.68	7.873	} Very high winds.
45	66.01	9.963	
50	73.35	12.300	A storm or tempest.
60	88.02	17.715	A great storm.
80	117.36	31.490	A hurricane.
100	146.70	49.200	} A dreadful hurricane that overturns buildings, trees, &c.

To which may be added a still more remarkable instance of the impetuosity of a hurricane, as related by M. Rochou. The velocity of the wind, as observed by him, was no less than 109 miles an hour, or 159.88 feet per second ; and its force against a perpendicular plane of a foot square, was estimated at 58.45 pounds avoirdupois. Of the causes and theory of winds, many very able philosophers have treated largely ; as Des Cartes, Rohault, Bacon, De Luc, Halley, Prevost, Derham, Eles, Muschenbroeck, Dalton, and others. We have

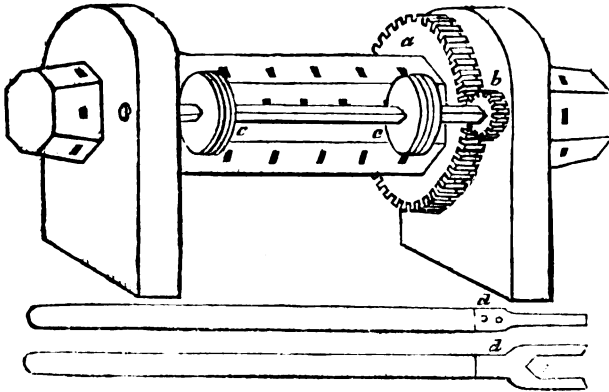
not room to introduce even a short abstract of their several theories, but must refer the curious reader to their writings, and the various parts of the *Philosophical Transactions*.

**WIND-INSTRUMENTS.** An accurate acquaintance with the principles of acoustics is essential to the scientific construction of every species of musical instrument, but especially those which owe their operation to the action of the wind. Wind-instruments generally produce their effects by the vibrations of a column of air confined at one end, and either open or shut at the other. These vibrations are determined mainly by the length of the sounding column; yet inferior and subordinate ones are found to coexist with the fundamental one. The whole column spontaneously divides itself into portions equal to the half, the third, or the fourth of its longitudinal extent. In mixed wind-instruments, the vibrations or alterations of solid bodies are made to cooperate with the vibrations of a given portion of air. Thus, in the trumpet, and in horns of various kinds, the force of inflation, and perhaps the degree of tension of the lips, determines the number of parts into which the tube is divided, and the harmony which is produced. In the serpent the lips cooperate with a tube, of which the effective length may be varied by opening or shutting holes; and the instrument which has been called an organised trumpet, appears to act in a similar manner. The trombone has a tube which slides in and out at pleasure, and changes the actual length of the whole instrument. The hautboy and the clarinet have mouth-pieces of different forms, made of reeds or canes; and the reed-pipes of an organ, of various constructions, are furnished with an elastic plate of metal, which vibrates in unison with the column of air which they contain.

The longitudinal vibrations of a column of air, contained within a tube open at both ends, are powerfully excited, and very loud and clear tones produced by the inflammation of a streamlet of hydrogen gas. This curious experiment was first made in Germany, and it is very easily performed. A phial, being partly filled with dilute sulphuric acid, a few bits of zinc are dropped into the liquid. As the decomposition of the water embodied with the acid now proceeds, the hydrogen gas, thus generated, flows regularly from the aperture. The gas being first ignited, and a glass tube placed over the exit-pipe, the burning speck at its point instantly shoots into an elongated flame, and creates a sharp and distinct musical sound. This effect is not owing to any vibrations of the tube itself; for it is in no way altered by tying a handkerchief tightly about the glass, or even by substituting a cylinder of paper. The tremor excited in the column of air is, therefore, the sole cause of the incessant tone, which only varies by a change in the place of the flame, or a partial obstruction applied at the end of the tube. The exciting force must necessarily act by starts, and not uniformly. The column of air contained within the tube is in reality agitated by a series of incessant strokes, or sudden expansion; and it is probable, that an instrument possessing great power in a small compass, might be thus constructed.

**WINDLASS.** A machine used on board ships, chiefly for raising the anchor. It may be regarded as a modification of the mechanical power termed the wheel and axle, employed to raise buckets from wells, and for infinite variety of other uses. In nautical affairs, it consists of a large cylindrical piece of timber, moving round its axis in a vertical position, and is supported at its two ends by two pieces of wood called knight-heads, which are placed on the opposite sides of the deck, near the foremast: it is turned about by levers called handspikes, which are for this purpose thrust into holes bored through the body of the machine. The lower part of the windlass is usually about a foot above the deck: it is furnished, like the capstan, with strong iron pauls, to prevent it from turning backwards by the pull of the cable and anchor, or from being strained by the violent jerking of the ship in a tempestuous sea. The pauls fall into notches cut in the surface of the windlass, and lined with plates of iron. The windlass is heaved round by the men who work it throwing their weight upon the ends of the handspikes, which, moving through a much greater space than the length

of the cable taken up, constitute, in effect, an increase of power equal to much greater space: and by this simple mechanical arrangement anchors of much greater weight than that of the men employed, are raised direct from the sea. It however requires considerable dexterity to manage the handspike to the most advantage: the sailors who perform it rise simultaneously upon the windlass, insert their levers, throw their weights to the extremities, by a sort of jerk, all at the same instant, and weigh up the anchor six or eight inches at each pull,—the motions of the men being regulated to time by the howling of one of the crew. To save the time employed by the men in working a windlass in raising the handspikes from one slot to another, and also to give additional power to the machine, a patent was recently taken out by Mr. George Straker, a ship-builder, of South Shields,—a perspective sketch of whose windlass is subjoined. The increase of power he obtains by fixing on the barrel of the windlass, at one end,



a spur wheel *a*, which is acted upon by a pinion *b*, whose axis turns in bearings which support the windlass itself. Upon each end of the pinion axis are fixed two circular appendages *c c*, which are formed like two crown ratchet wheels, with only four teeth in each, placed face to face, and with the teeth directly opposite to each other, and only about an inch apart, so as to leave cavities between them of a suitable form to receive handspikes of the shape represented in the above cut,—the upper figure showing the operating end edgewise, and the lower figure the same broadways; wherein is shown a fork *c d* end is of course made of iron, and sufficiently thin to pass up between the projecting teeth of the pieces *c c*, when withdrawn a few inches; and by this means it can be raised with facility; and when it is pushed in, its shoulders *d d* rest on the projecting teeth, which enables the men to turn the pinion, and through that medium the windlass acts with great power. It will be perceived that by this arrangement, instead of having, as usual, to withdraw the handspikes, and insert them in a fresh hole every time they are brought down to the deck, they have only to be withdrawn until their shoulders can pass outside of the projecting teeth, moved past a second pair of teeth, and then returned again, till the shoulders rest firmly upon them. This is evidently a very convenient and excellent method of working a windlass, and might be applied, as stated by the patentee in his specification, to windlasses, without the intervention of the spur-wheel and pinion.

**WINDMILL.** A mill of any kind actuated by the impulse of the wind. They are of two kinds—*vertical* and *horizontal*.

Vertical windmills (to which a decided preference has been hitherto given)

usually consist of a strong shaft or axis inclining a little upwards from the horizon, with four long yards or arms fixed to the highest end, perpendicular to the shaft, and crossing each other at right angles. Into these arms are mortised several small cross bars, and to them are fastened two, three, or four long bars, running in a direction parallel with the length of the arms; so that the bars intersect each other, and form a kind of lattice-work, on which the cloth is spread to receive the action of the wind. These are called the sails, and are in the shape of a trepezium, usually about nine yards long and two wide. The direction of the wind being always very uncertain and variable, it becomes necessary to provide some contrivance for bringing the sails into a proper position for receiving its impression. Two methods have been devised for this purpose, one of which is denominated the post-mill, the other, the smock-mill.

The post-mill is so called from the circumstance of the mill being built round a massive central post, made out of the whole trunk of a stout tree, which is sunk vertically in the ground, and supported in its position by oblique struts or braces, which extend from a platform on the ground to the middle of the post, leaving 10 or 12 feet of the upper part free from the braces. The part thus left free from obstruction is rounded and made to pass through a circular collar, formed in the flooring of the lower chamber, and to enter into a socket fixed into the flooring of the upper chamber, and to one of the strongest cross-beams, which must sustain the whole weight of the mill-house; so that by means of a pivot, or gudgeon, fastened on that part of the post which enters into the socket, the whole machine can turn about horizontally to face the wind. A strong framing, united by joints at the back of the mill-house, descends in a sloping direction to the ground, and is there fastened to short posts, when placed in the position required for the sails to be acted upon by the wind. To this frame a ladder is attached, which leads into or out of the mill-house. To the bottom of this frame a rope is fastened and conducted to tackle in the mill-house, by which the frame can be lifted from the ground, while its position is being changed, in the manner of a capstan post, to suit the wind.

The smock-mill does not depend upon a central post for its main support, but it is generally a strong independent building, the upper portion of which is usually a tower of the form of a truncated cone, constructed, of wood, and mounted upon a vertical wall of masonry, containing two or three floors, where the work of the mill is performed,—the tower above containing a vertical shaft, by which the motion and force is communicated from the sails to the mill-stones. The head or cap in the upper part of the mill is provided with a cap, which is contrived so that it may turn itself about as the wind changes; for this purpose there is a nearly horizontal framed projection at the back part of the head, which carries some small sails acting as a vane, there being, concentric with the axis, a large grooved ring, around which a circular hoop, provided with anti-friction rollers, traverses.

The velocity of motion of the sails or vanes is very considerable. Mr. Ferguson calculated the motion of the tips of the sails, even when operated upon by a very moderate wind, to be thirty miles per hour.

Horizontal windmills, as their name implies, are such as are worked by their sails revolving in a horizontal plane. All disinterested authors who have written on this subject condemn them, as being very inferior in effect to those of the vertical kind. Smeaton considered their effect to be only one-eighth, but Dr. Brewster shows that they have from one-third to one-fourth of the effect of the vertical. It is probable, however, that means may be discovered of improving them considerably.

To ascertain the best form and position of windmill-sails, Mr. Smeaton instituted a series of experiments, of which the results are given in the subjoined table :—

T A B L E,  
*Exhibiting the Results of Nineteen Sets of Experiments on Windmill Sails, of various Structures, Positions, and Extents of Surface.*

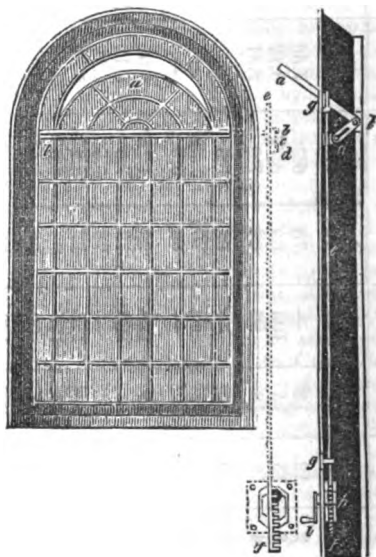
THE DESCRIPTION OF SAILS MADE USE OF.	Number.	Angle at the Extre- mities.	Greatest Angle.	Turns of the Sails unloaded.	Turns of the Sails at the Maxi- mum.	Load at the Maximum.	Greatest Load.	Product.	Extent of Surface.	Ratio of greatest Ve- locity to the Maximum.	Ratio of greatest Load to the Load at a Maximum.	Ratio of Surface to the Product.
		Degrees.	Degrees.			lb.	lb.		Sq. In.			
Plane Sails, at an angle of 55°	1	35	35	66	42	7.56	12.59	318	404	10.7	10:6	10:7.9
Plane Sails, weathered ac- cording to the common practice . . . . .	2	12	12	—	70	6.3	7.56	441	404	—	10:8.3	10:10.1
	3	15	15	105	69	6.72	8.12	464	404	10:6.6	19:8.3	10:10.15
	4	18	18	96	66	7.0	9.81	462	404	10:7	10:7.1	10:10.15
	5	9	26½	—	66	7.0	—	462	404	—	—	10:11.4
Weathered according to M'Laurin's Theory . . . . .	6	12	29½	—	70½	7.35	—	518	404	—	—	10:12.8
	7	15	32½	—	63½	8.3	—	527	404	—	—	10:13.
	8	0	15	120	93	4.75	5.31	442	404	10:7.7	10:8.9	10:11.
Sails weathered in the Dutch manner, tried in various positions . . . . .	9	3	18	120	79	7.0	8.12	553	404	10:6.6	10:8.6	10:13.7
	10	5	20	—	78	7.5	8.12	585	404	—	10:9.2	10:14.5
	11	7½	29½	113	77	8.3	9.81	639	404	—	10:8.5	10:15.8
	12	10	25	108	73	8.69	10.37	634	404	10:6.8	10:8.4	10:15.7
	13	12	27	100	66	8.41	10.94	580	404	10:6.6	10:7.7	10:14.4
Sails weathered in the Dutch manner, but enlarged to- wards the Extremities . . . . .	14	7½	22½	123	75	10.65	12.59	799	505	10:6.1	10:8.5	10:15.8
	15	10	25	117	74	11.08	13.69	820	505	10:6.3	10:8.1	10:16.2
	16	12	27	114	66	12.09	14.23	799	505	10:5.8	10:8.4	10:15.8
	17	15	30	96	63	12.09	14.78	762	505	10:6.6	10:8.2	10:15.1
Eight Sails, being Sectors of Ellipses, in their best positions . . . . .	18	12	22	105	64½	16.42	27.87	1059	854	10:6.1	10:5.9	10:12.4
	19	12	22	99	64½	18.06	—	1165	1146	10:5.9	—	10:10.1

**WINDOW.** An aperture in the wall of a building, for the admission of light and air. Modern windows are almost uniformly furnished with glazed frames, that open and close, besides shutters and blinds, by which the admission of the light and air may be easily regulated at pleasure.—See the Article **GLAZING.** In this place we propose to notice several improvements which have of late years been made in the mechanical construction of windows.

It has frequently been a subject of complaint, that our public edifices are either insufficiently provided with the means of ventilation, or the arrangements for that purpose are very inconvenient. The oldest mode with which we are acquainted is that of casements hung upon hinges, and fastened by a latch. A later and more improved method was to hang the casements so as to swing upon centre pivots; the opening and shutting of these casements by pulleys and lines is always accompanied with noise, and they afford no defence from a shower of rain, nor to the prejudicial effects of the cold air descending on the heads of the persons assembled near to the windows. Another mode, lately introduced, is to cut out of the windows a space to receive the half of a glazed hopper, which is attached to the window, projecting inwards, having a flap on the top, lying horizontally, and opening upwards. These hoppers are extremely

Fig. 1.

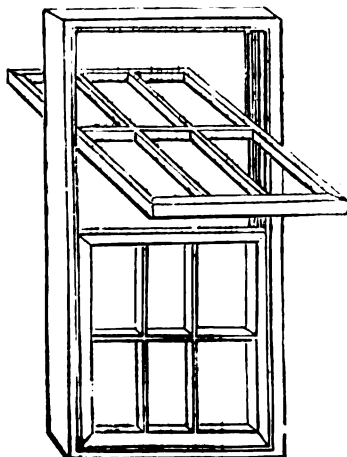
Fig. 2.



unsightly in themselves, but are rendered still more so by the dust which lodges on them; which dust is blown into the building when the flap is opened for the admission of air. To remedy these inconveniences, Messrs. W. and D. Baily some years ago invented the arrangement delineated in the preceding page; by which a ready mode of action on the upper part of the window is obtained by very simple machinery, while the symmetry of the window is preserved. *Fig. 1* gives a front inside view of a window, with the apparatus attached, and *fig. 2* is a side view of the same; *a* shows the flap of the window open; *b b* a bar to which the base of the flap is fixed, and on which it turns; *e* a lever, having one end fastened to the extremity of the bar *b*, and furnished at the other end with an eye, which receives the pin or stud *d*; this stud is fixed on the vertical rod *e*, which terminates below in a rack *f*, and is secured in an

upright position by the loops or guides *g g*. through which it passes; *h* is a lantern pinion of two teeth, which when turned round by means of the winch *i*, takes into the notches of the rack, and consequently draws down the rod *e*, or raises it, according to the direction in which the winch is turned. In the first case, the stud *d* draws the lever down, and consequently *opens* the window; in the latter the stud is raised, and with it the lever, which *shuts* the window. It may be proper to observe, that in case of the upper part of the window being square, and not having any mullions, it will be found necessary (to prevent the entrance of the air at the side of the casement, when it opens) to have a frame with two angular sides attached to the windows, and these sides must have a small return rebate for the casement to fall against when it is fully opened, which will prevent any inconvenience arising from the form of the window.

Servants and others employed in the cleaning and repairing of such windows in general provide so indifferently for their security, while employed on the outside, that numerous accidents have occurred,—some, of the most deplorable nature. The construction of the sash windows that we have now to notice, will not only effectually prevent these accidents, but will remain a permanent convenience to the house in which they may be adopted. In appearance these



sashes resemble those of the common kind, and the upper and lower sash may be moved up and down in a similar manner. The outside of the sash may also be turned into the room, so that it may be easily painted, glazed, or cleaned, by a person standing within the room, without the necessity of removing the slips or beadings; by doing which the glass is frequently broken, and the beads lost, left loose, or dismatched, and a considerable expense incurred. The frame of the window is fitted with grooves, weights, and pulleys, in the usual manner; the fillets on the sash are not made in the same piece with the sash frame, but fastened thereto by pivots, about the middle of the sash; upon these pivots the sash is turned round at pleasure, so as to get at the outside without disturbing the fillets or grooves. When the sash is placed vertically (as the lower one in the figure) a spring catch on each side of it shoots into, and takes hold of the sliding fillets; so that in this case the sash slides up or down in the usual manner, but can be immediately released, and turned inside-out by pushing back the springs, and at the same time pulling the sash inwards. This invention originated with Mr. Marshall, who communicated it to the Society of Arts; but the invention, with some unimportant modifications, was subsequently patented by Mr. Tuely, probably from ignorance of Mr. Marshall's prior claims. We notice this fact, as windows of this kind are sometimes called Marshall's, and at others Tuely's patent revolving windows. On account of the additional expense (from six to twelve shillings) of these windows above the ordinary kind, the builders do not encourage them; but this additional expense is scarcely worthy of notice by a private individual in building, when the important advantages it confers are taken into account.

To keep the sashes of ordinary windows at equal distances from the sides, so that they may not be impeded in drawing up and down, (as is often the case, on account of the sash swinging as it is suspended by the top,) Mr. Woolwich has proposed the simple appendage represented in the annexed cut. *Fig. 1* is a plate of iron two inches long by one inch wide; to the lower part of which is fixed a spring *b*, that carries a roller at its upper end, and at *c c* are two holes



to admit screws to fit it. Its application to a sash is shown at *d d*. The groove may be cut in the side of the sash sufficiently deep for the whole to be buried

Fig. 1.

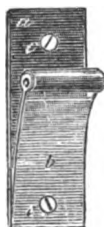
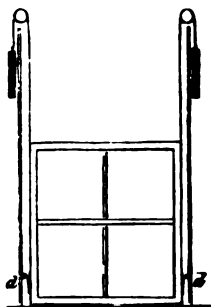


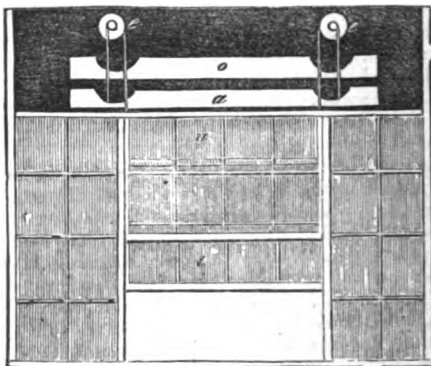
Fig. 2.



when the spring is forced in, as the elasticity of the spring will project the roller sufficiently to steady the sash.

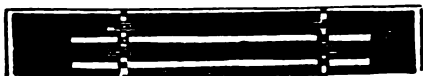
One of the principal objections to sliding sashes in shop windows, is the necessity in most cases of making a broad casing for the balance weights to pass up and down, which excludes the light, and so much space for the exhibition of goods, and is besides unsightly, according to the prevailing taste in these matters. To obviate these objections, sliding sashes have sometimes been made with a long train of pulleys and lines, to carry the weights to a distant situation, where there would be the least incumbrance. Mr. Lockart, of Poland-street, has however ingeniously contrived to place the weights in a horizontal position above the window, which is a very convenient situation, and the means adopted

Fig. 1.



for that purpose are calculated to work well. Fig. 1 in the annexed sketches represents an elevation, and Fig. 2 a plan, the corresponding letters in each

Fig. 2



referring to similar parts. *u* is the upper sash closed; *l* the lower sash partly opened; *a* the weight to the upper window; *o* the weight to the lower window; *e e* are the pulleys on which the lines run. The dark space above the window has been drawn too large in proportion to the other parts, but with the view of showing the arrangement more clearly. When the lower sash *l* is pulled down, the weight *o* is drawn close up under the pulleys, the curved pieces being cut out of the weights for that purpose. When the upper sash *u* is brought down, the weight *a* is drawn up close to the pulleys.

To arrange these several parts to act properly, it will be necessary to observe the depth of the casing above the window, where the weights are to move; if that be (for instance) the fourth part of the range of the sashes in their grooves, then the pulleys on which the lines that suspend the sashes are coiled, must be four times the diameter of their axes, that take up the lines from the weights. As by this arrangement, the weights only move through a fourth part of the space of the sashes in the same time (by the cords passing round pulleys showing these relative proportions,) it follows that the weights must be four times the weight of the sashes to balance them; and to save space, the weights should be of lead. By this arrangement it will be observed that there is only one case for the weights instead of two, and that the situation above the window is more convenient for repair than at the sides. For pastry-cooks, butchers, and market shops generally, this improvement offers great convenience and advantage.

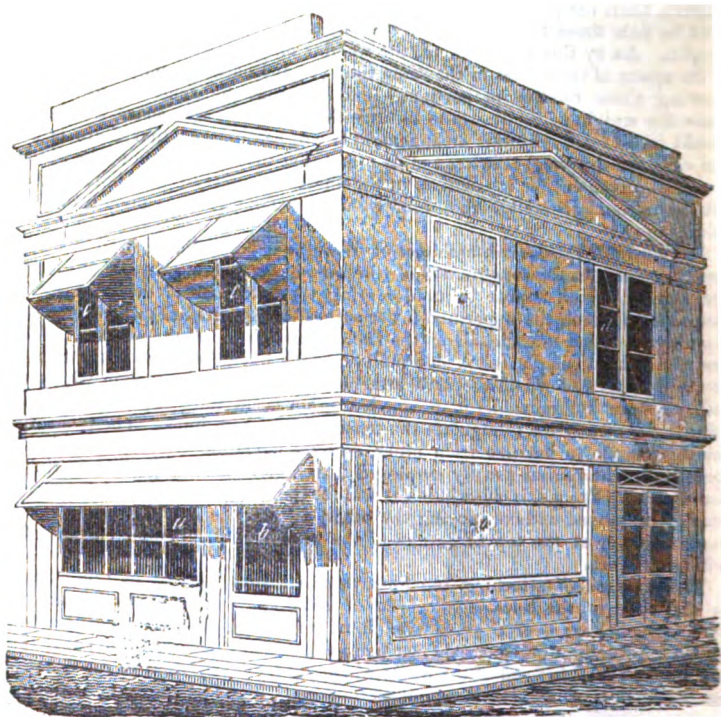
Mr. Thomas Prosser, an architect of Worcester, patented, in 1830, "certain improvements in the construction of window-sashes, and in the mode of hanging the same," which appear to us deserving the attention of the reader. He proposes to attach the upper and lower sashes to the same lines which pass over a pulley attached to each side of the frame near the top of the window. These are of the kind usually called side pulleys, which have their axes at right angles to the surfaces to which they are attached. The small frames in which the pulleys turn are movable, in dovetailed grooves, in the window-frames, and adjustable by a screw to regulate the tension of the sash lines. The two sashes are thus made to balance each other, entirely obviating the necessity for the metallic counterpoises usually employed to facilitate the raising and lowering of the sashes. From this description it will be perceived that one of the sashes cannot be moved without moving the other, so that the opening can never be made entirely at the top or bottom of the window, but an equal portion of it will be at each.

The method of attaching the lines to the sashes consists in tying neatly to the ends of the lines small pieces of metal, with longitudinal rectangular slits, which pass over T studs fixed into the sashes, with their heads across, by which the lines are secured from being accidentally detached when once they are hooked on. Instead of the beads which are generally fixed to the frame on each side of a window-sash, as guides to keep it in its place while stationary, and to preserve their perpendicular position while elevated or depressed, this patentee fixes a single rod into the frame, which fits accurately into a groove in the side of the sash. This constitutes a fitting less pervious to the weather than that usually adopted, at the same time that it affords great facility in cleaning the windows; for, as the guide-rod of the lower sash does not extend more than half-way down, so that the lower sash being elevated to the top of the window, escapes its guide-rod, and may be turned inside-out, and the upper sash being lowered to the bottom may be similarly reversed; so by this means all parts of the window can be brought within reach of a person in the room, for the purpose of cleaning or repairing.

We now proceed to describe a mode of securing house and shop windows from the depredations of robbers, which is applicable also to doors, gates, safes, &c., which was the subject of a patent granted to Messrs. Don and Smith, of Pentonville; and consists in the construction and adaptation of metallic shutters, arranged horizontally, in such manner that when the window or door is closed, each shutter forms a handsome panel; and when opened, they are entirely withdrawn, and deposited behind the entablature, or in the brickwork above or

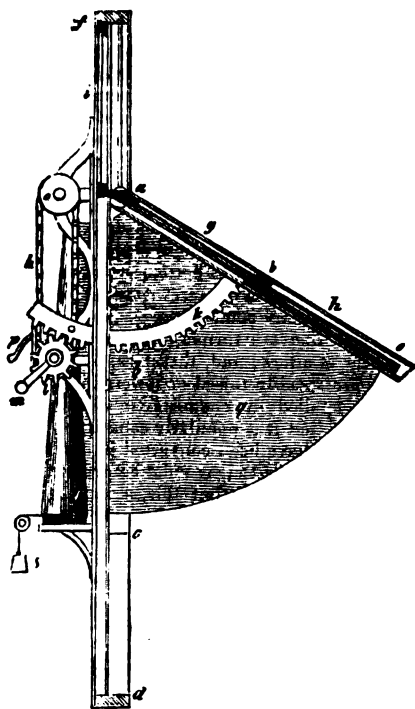
below the window. The patentees likewise claim the public patronage for another property possessed by their metallic shutters,—that of a ready conversion into sun-blinds; but there will doubtless be many exceptions taken to the employment of so quick a conductor of heat, and of so ponderous a material as iron, for such a purpose. But whatever may be the substance used, the obviating of the necessity of sun-blinds as a separate appendage is worthy of consideration.

In the annexed engraving is represented a perspective view of the corner-house of a street, in which the metallic shutters and sun-blinds are exhibited as applied thereto. At *a* is a shop-window, and at *b* a shop-door, over which is



projected two of the metallic shutters as a sun-blind, having also end blinds of silk cloth or other desirable substance, in the form of sectors of circles. In this case the third shutter, which forms the set, is drawn up and deposited behind the entablature. On the first floor above the shop, *c c* exhibits the application of the same thing on a small scale to private windows. At *d* is shown a window unclosed; that is, the shutters are supposed to be withdrawn entirely, and deposited immediately above or below it, as the patentees adapt them to both situations. At *e* is a window entirely closed by the shutters, presenting a barrier against burglars, said to be bullet-proof; and at *o* is shown one of the shop windows, similarly closed. The shutters are made in the following manner. Having determined the number of plates or pannels a shutter is to contain, (usually three or four,) the iron or steel plates are well hammered in the manner of saw plates, so as to condense the metal and flatten the surfaces. The plates are then enclosed in grooves made in a rectangular frame of bar-iron, and strongly rivetted thereto. Thus framed, they are connected together at

pleasure, by the lower horizontal bar of one, and the upper one of the next being cut into acute angles, that hook into one another; and they are thus drawn up or let down in succession, by sliding with their vertical sides in deep grooves cut in bars of wrought iron, which form the styles to the window. The upper portion of these grooved metallic styles is made to separate from the lower, by turning upon a pivot or hinge joint, at the top of the window, by which means the shutters, while contained in the grooves, may be projected out to an angle of about 60 degrees from the perpendicular, and form the sun-blinds. The patentees have designed several movements for raising or lowering the shutters; but we adopt that which is specified under the patent, with reference to the annexed sectional figure. From *a* and *b* to *e* and *d*, is one of



the side styles to the window; from *a* to *f* is a continuation of the style and frame behind the entablature, where all the three shutters *g*, *h* and *i*, are drawn up and deposited, when the shutters are not in use. The groove for the upper shutter *g* does not permit it to descend lower than *b*, nor does the groove for the middle shutter *h* permit that to descend further than *c*, but the groove for the lower shutter *i* is extended from the top *f* to the bottom *d*. The sun-blind is projected only when they are all down, by which means the two upper shutters are unlocked from the lower, and the latter is afterwards drawn up to the top, as shown in the figure. To the movable part of the style is fixed a curved rack *k*, the teeth of which gear into those of a pinion *l*; the axis of this pinion carries a winch *m*, by turning which, the sun-blind is thrown out, or drawn in. To steady the motion of the blind, the movement described is made to communicate with a similar rack and pinion on the opposite side of the window; for this purpose there is placed on the axis of the pinion *l* behind it, a small chain

pulley, round which an endless pitched chain  $n$  passes, and also over a similar pulley  $o$ ; the axis of the last mentioned is a long shaft, extending horizontally across the window (above the glass) to the opposite side, where a corresponding apparatus projects, and supports that side of the sash blind. In order to fix the blind at any required angle that it may be desired to project it, there is on the axis of  $i$ , a ratchet-wheel, with a pall above  $p$ , which falls into the teeth on its periphery, and prevents its return without being lifted up.

The side or end blinds, one of which is represented at  $g$ , are made of cloth, or other flexible substance; one side is attached to the projecting part of the style, and the other, passing through a long and very narrow slit, is attached to a conical roller  $r$ ; when the shutters composing the blind are drawn in, the conical roller is turned by means of a descending weight  $s$ , which then winds upon it, in even layers, the sectorial blind. To the middle of the lower edge, and at the back of the bottom shutter  $i$ , a suitable line or chain is attached. This line is carried up vertically, then passes over a pulley at the top of the frame, and from thence over side pulleys down to a barrel on one side, on which the cord is wound. The lower ledge of the shutter  $i$  has likewise a projecting ledge; on the drawing up of the lower shutter, therefore, by the cord and winch described, the bottom edges of the middle and upper shutters come in contact with, and rest upon the ledge, and are thereby carried up altogether into the casing behind the entablature; to keep the shutters in the situation they are thus put, a pall drops into the teeth of another ratchet-wheel placed on the axis of the winding barrel.

Subsequent improvements have been effected upon the foregoing, which chiefly consist in substituting, for the movement we have described, long revolving screws extending from top to bottom on each side of the window. A simultaneous motion is effected in the screws, by means of a bar extending across the bottom of the window, and connecting, by bevil wheels, both screws with a winch handle by which they are turned. Upon the screws are fitted nuts, to which are attached the shutters; and, therefore, by the operation of turning the handle, the shutters are steadily raised or lowered into or out of their case.

**WINE.** A term applied by chemists to all liquids that have become vinous by fermentation; but it is popularly considered as confined to saccharine vegetable substances that have been converted into a vinous liquid. It seems to be a necessary condition, that sugar must be present in a vegetable, to enable it to ferment and become vinous; but this, according to late discoveries, will not exclude starch, gum, and other similar products, which are capable of being converted into saccharine matter. Lavoisier stated that pure sugar alone would not ferment, but that some extractive matter, or yeast, must be added to enable it to undergo the vinous fermentation; and he considered that the effects of this fermentation consisted in separating the sugar, which is an oxide, into parts; in oxygenating the one, at the expense of the other, to form carbonic acid; in disoxygenating the other in favour of the first, to form a combustible substance termed alcohol; so that, were it possible to combine these two substances, the alcohol and the carbonic acid might reproduce sugar. It is necessary to remark, that the hydrogen and carbonic do not exist in the state of oil in alcohol, being combined with a portion of oxygen, which renders them miscible with water. These three principles, therefore, the oxygen, the hydrogen, and the carbonic, are here in a kind of equilibrium; and, in fact, by causing them to pass through a red-hot tube of glass or porcelain, we may recombine them, two and two together, and the product will be water, hydrogen, carbonic acid, and carbon.

In all wines may be distinguished an acid, alcohol, tartar, an extractive matter, aroma or odour, and a colourless principle,—the whole being diluted or dissolved in a smaller or larger proportion of water. An acid exists in all wines, but all are not acid in the same degree. Of some wines a natural acidity is the principal characteristic; those produced from grapes not perfectly ripe, or that grow in moist climates, are of this kind; whilst such as are the product of the fermentation of grapes that have attained complete maturity and sweetness, contain but a very small quantity of acid. The proportion of acid appears, therefore, to be in the inverse ratio of the saccharine principle, and consequently of the alcohol, which is produced by the decomposition of the sugar. Alcohol forms the true

characteristic of wine. It is the product of the decomposition of sugar; and its quantity is always proportionate to that of the sugar that has been decomposed. Alcohol abounds more in some wines than it does in others; those of hot climates contain a large quantity of it; whilst those of cold climates contain scarcely any. Ripe and sweet grapes produce it in abundance; but the wines made of grapes that are unripe, watery, and sour, yield very little.

The following is Mr. Brande's valuable table of the quantity of alcohol in different kinds of wine and spirituous liquors:—

	Proportion of Alcohol per cent. by measure.
1. Lissa, average of two samples . . . . .	25.41
2. Raisin wine, average of three samples . . . . .	25.12
3. Marsala, average of two samples . . . . .	25.9
4. Madeira, average of four samples . . . . .	22.27
5. Currant wine. . . . .	20.55
6. Sherry, average of four samples . . . . .	19.17
7. Teneriffe . . . . .	19.79
8. Colares . . . . .	19.75
9. Lachryma Christi . . . . .	19.70
10. Constantia, white . . . . .	19.75
11. Ditto . . red . . . . .	18.92
12. Lisbon . . . . .	18.94
13. Malaga, (1666) . . . . .	18.94
14. Bucellas . . . . .	18.49
15. Red Madeira, average of two samples . . . . .	20.35
16. Cape Muschat . . . . .	18.25
17. Cape Madeira, average of three samples . . . . .	20.51
18. Grape wine . . . . .	18.11
19. Calcavella, average of two samples . . . . .	18.65
20. Vidonia . . . . .	19.25
21. Alba Flora . . . . .	17.26
22. Malaga . . . . .	17.26
23. White Hermitage . . . . .	17.43
24. Roussillon, average of two samples . . . . .	18.13
25. Claret, average of four samples . . . . .	15.10
26. Malmsey Madeira . . . . .	16.40
27. Lunel . . . . .	15.52
28. Sheraaz . . . . .	15.52
29. Syracuse . . . . .	15.28
30. Sauterne . . . . .	14.22
31. Burgundy, average of four samples . . . . .	14.57
32. Hock, average of three samples . . . . .	12.08
33. Nice . . . . .	14.63
34. Barsac . . . . .	13.86
35. Tent . . . . .	13.30
36. Champagne, average of four samples . . . . .	12.61
37. Red Hermitage . . . . .	12.32
38. Viu de Grave, average of two samples . . . . .	13.37
39. Frontignac . . . . .	12.79
40. Cote Rotie . . . . .	12.32
41. Gooseberry wine . . . . .	11.84
42. Orange wine, average of six samples, made by a London manufacturer . . . . .	11.26
43. Tokay . . . . .	9.88
44. Elder wine . . . . .	9.87
45. Cider, highest average . . . . .	9.87
Ditto lowest ditto . . . . .	5.21
46. Perry, average of four samples . . . . .	7.26
47. Mead . . . . .	7.32

	Proportion of Alcohol per cent. by measure.
48. Ale, (Burton) . . . . .	8.88
Ditto (Edinburgh) . . . . .	6.20
Ditto (Dorchester) . . . . .	5.56
49. Brown Stout . . . . .	6.80
50. London Porter, average . . . . .	4.20
51. Ditto Small Beer, ditto . . . . .	1.28
52. Brandy . . . . .	53.39
53. Rum . . . . .	53.68
54. Gin . . . . .	51.60
55. Scotch Whiskey . . . . .	54.32
56. Irish ditto . . . . .	53.90

Tartar exists in verjuice, as also in must; it contributes to facilitate the formation of alcohol. When left at rest in casks, it deposits itself upon the sides, forming a crust more or less thick, with crystals of irregular forms. Some time before the vintage, when the casks are to be got ready for receiving the new wine, they are staved, and the tartar detached from them, in order to be employed in the different uses of commerce. This salt has little solubility in cold water, but considerably more in boiling water. It scarcely dissolves at all in the mouth, and it resists the pressure of the teeth. The extractive principle abounds in must, when it appears to be dissolved by the aid of the sugar; but when the saccharine principle is decomposed by means of fermentation, the quantity of extractive matter sensibly diminishes, a part of it deposits itself in a fibrous form, and this deposit, which principally constitutes the lees, is the more considerable in proportion as the fermentation is more gentle, and the alcohol more abundant. This deposit is always mixed with a considerable quantity of tartar. There always exists in wine, a proportion of extractive matter in a state of solution, which may be separated from it by means of evaporation. It abounds more in new wines than in old ones; and the older the wine grows, the more completely is it freed from the extractive principle. All natural wines have an odour more or less agreeable to the smell. Some of them owe their reputation in a great measure to the perfume which they exhale. This is the case with Burgundy. This perfume is lost by too violent a fermentation, and becomes stronger by age. It seldom exists in very spirituous wines, either because it is concealed by the strong smell of the alcohol, or because it has been destroyed or dissipated by the violent fermentation that was requisite to develop the spirit. The colouring principle of wine belongs to the skin of the grape, for when the must is suffered to ferment without it, the wine is white. This colouring principle does not dissolve till the alcohol is developed; it is only then that the wine acquires its colour, which is deeper in proportion to the violence of the fermentation. If we expose bottles filled with wine to the rays of the sun, a few days are sufficient to precipitate the colouring principle in large pellicles; the wine losing neither its perfume nor its strength.

A very great number of vegetable substances may be made to afford wine, as grapes, currants, mulberries, elders, cherries, apples, pulse, beans, peas, turnips, radishes, and even grass itself. Hence, under the class of wines, or vinous liquors, come not only wines, absolutely so called, but also ale, cyder, &c. The term wine is however in a more particular manner appropriated to the liquor drawn from the fruit of the vine. The process of making wine is as follows:—When the grapes are ripe, and the saccharine principle is developed, they are then pressed, and the juice which flows out is received in vessels of a proper capacity, in which the fermentation appears, and proceeds in the following manner. At the end of several days, and frequently after a few hours, and according to the heat of the atmosphere, the nature of the grapes, the quantity of the liquid, and temperature of the place in which the operation is performed, a movement is produced in the liquor, which continually increases; and the volume of the fluid increases; it becomes turbid and oily; carbonic acid is disengaged, which fills all the unoccupied part of the vessel; and the temperature rises to

75° Fahrenheit. The skins, stones, and other grosser matters of the grapes, are buoyed up by the particles of disengaged air that adhere to their surface, are variously agitated, and are raised in form of a scum, or soft and spongy crust, that covers the whole liquor. During the fermentation, this crust is frequently raised, and broken by the air disengaged from the liquor, which forces its way through it; afterwards the crust subsides, and becomes entire as before. These effects continue while the fermentation is brisk, and at last gradually cease: then the crust being no longer supported, falls in pieces to the bottom of the liquor. At this time, if we would have a strong and generous wine, all sensible fermentation must be stopped: this is done by putting the wine into close vessels, and carrying these into a cellar or other cool place. After this first operation, an interval of repose takes place, as is indicated by the cessation of the sensible effects of the spirituous fermentation; and thus enables us to preserve a liquor, no less agreeable in its taste, than useful for its reviving and nutritious qualities when drunk moderately. In this new wine a part of the liquor probably remains, that has not fermented, and which afterwards ferments, but so very slowly, that none of the sensible effects produced in the first fermentation are here perceived. The fermentation, therefore, still continues in the wine, during a longer or shorter time, although in an imperceptible manner; and this is the second period of the spirituous fermentation,—which may be called the imperceptible fermentation. We may easily perceive that the effect of this imperceptible fermentation is the gradual increase of the quantity of alcohol. It has also another effect no less advantageous; namely, the separation of the acid salt called tartar from the wine. This matter is therefore a second sediment that is formed in the wine, and adheres to the sides of the containing vessels. As the taste of tartar is harsh and disagreeable, it is evident that the wine, which, by means of the insensible fermentation, has acquired more alcohol, and has disengaged itself of the greater part of its tartar, ought to be much better and more agreeable; and for this reason chiefly, old wine is universally preferable to new wine. But insensible fermentation can only ripen and meliorate the wine, if the sensible fermentation have regularly proceeded, and been stopped in due time. We know certainly, that if a sufficient time have not been allowed for the first period of the fermentation, the unfermented matter that remains, being in too large a quantity, will then ferment in the bottles or close vessels in which the wine is put, and will occasion effects so much more sensible as the first fermentation shall have been sooner interrupted; hence these wines are always turbid, emit bubbles, and sometimes break the bottles, from the large quantity of air disengaged during the fermentation.

We have an instance of these effects in the wine of Champagne, and in others of the same kind. The sensible fermentation of these wines is interrupted, or rather suppressed, that they may have this sparkling quality. It is well known that these wines make the corks fly out of the bottles; that they sparkle and froth when they are poured into glasses; and lastly, that they have a taste much more lively and piquant than wines that do not sparkle; but this sparkling quality, and all the effects depending on it, are only caused by a considerable quantity of carbonic acid gas, which is disengaged during the confined fermentation that the wine has undergone in close vessels. This air not having an opportunity of escaping, and of being dissipated as fast as it is disengaged, and being interposed betwixt all the parts of the wine, combines in some measure with them, and adheres in the same manner as it does to certain mineral waters, in which it produces nearly the same effects; when this air is entirely disengaged from these wines they no longer sparkle, they lose their piquancy of taste, become mild, and even almost insipid.

Such are the qualities, Dr. Ure observes, that wine acquires in time, when its first fermentation has not continued sufficiently long. These qualities are given purposely to certain kinds of wine, to indulge taste or caprice; but such wines are supposed to be unfit for daily use. Wines for daily use ought to have undergone so completely the sensible fermentation, that the succeeding fermentation shall be insensible, or at least exceedingly little perceived. Wine, in which the first fermentation has been too far advanced, is liable to worse



inconveniences than that in which the first fermentation has been too quickly suppressed ; for every fermentable liquor is, from its nature, in a continual intestine motion, more or less strong according to circumstances, from the first instant of the spirituous fermentation, till it is completely purified ; hence, from the time of the completion of the spirituous fermentation, or even before, the wine begins to undergo the acid, or acetous fermentation. This acid fermentation is very slow and insensible, when the wine is included in very close vessels, and in a cool place ; but it gradually advances, so that in a certain time the wine, instead of being improved, becomes at last sour. This evil cannot be remedied ; because the fermentation may advance, but cannot be reverted.—*Fourcroy, Ure, Brande. Oxford Cyclopaedia.*

**WIRE.** Metallic threads, or fine rods, produced by forcibly drawing the ductile metals through a hole of less area than their previous transverse sections. The sizes of which wire are made are from three-eighths of an inch in diameter to that of the four-thousandth part of an inch. For the purposes of embroidery and similar work, gold and silver are commonly drawn to such fineness as to be flexible, and as conveniently wrought with a needle, as the filaments of silk, flax, &c. with which they are usually mixed. See the articles GOLD and SILVER.

The earliest attempt to draw ductile metal into threads, by forcing them through holes in a steel plate, does not appear to be determined. At first, wire was formed entirely by the hammer ; and this process of art soon became a distinct trade. Beckman observes, "As long as the work was performed by the hammer, the artists at Nuremberg were called *wire-smiths*, but after the invention of *drawing* iron, they were called *wire-drawers*, or *wire-millers*. Both these appellations occur in the history of Augsburg, so early as the year 1351, and in that of Nuremberg, in 1360 ; so that, according to the best information I have been enabled to obtain, I must class the invention of the drawing-iron, or proper wire-drawing, among those of the fourteenth century." About two hundred years, however, elapsed before the art was introduced into this country ; nevertheless, the skill of our native artists soon enabled them to surpass the foreign manufacture, if any reliance can be placed in the statement contained in a proclamation of King Charles I. in 1630, wherein it is set forth, "That iron-wire is a manufacture long practised in the realm, whereby many thousands of our subjects have long been employed ; and that English wire, of the toughest and best Osmond iron, a native commodity of this kingdom, and is much better than what comes from foreign parts, especially for making wool-cards, without which no good cloth can be made."

For the manufacture of wire for piano-fortes and other musical instruments, Berlin has long been celebrated ; and it still deserves a preference for these purposes, in the opinion of many of our artists.

For making iron wire, none but the very best and toughest iron should be used ; that made entirely from charcoal and of the Cumberland ore having the preference. Formerly the bars were reduced to the required sizes for the wire-drawer by tilting it ; but now we understand the manufacturers roll the bars down through small grooved rolls to very small sizes, and thus materially save the labour of drawing. The rolls for this purpose are the same as described in the article IRON (which see,) but are superiorly finished, and fitted up with great accuracy of adjustment, so as to roll very perfect cylinders of wire down to an eighth of an inch in diameter. The rollers are generally from seven to eight inches in diameter, and make upwards of 300 revolutions per minute ; so that the rapidity with which this rolled or "black wire," (as it is sometimes called, to distinguish it from the bright, or drawn-wire,) is made, may be readily conceived. For the rims of pots, kettles, and other kinds of "hollow ware," as made by the tinmen or braziers, wherein the copper or tinned plate is wrapped round the wire, the black wire is equally useful with the bright ; for these purposes, and all others where the wire is hidden, or is to be painted, the rolled black wire is preferred, on account of its greatly inferior cost. Whether wire be drawn by water, steam, or hand-power, the process is nearly the same, and the tools very similar. In order to get the end of the wire through the first reducing hole in the draw-plate, it is sharpened by hammering or filing ; being then inserted through the plate, the latter is laid so as to take its bearing

against two stout pins fixed vertically in a solid, firm, bench, and the end of the wire is gripped by a pair of pincers attached to a chain; the cross lever of these pincers are so formed, that the chain when pulled has a tendency to draw them together, and in proportion to the force applied to them, do they bite or gripe the wire; by means of a powerful lever the wire is now drawn through the hole in the plate, which is well lubricated with grease; and when a sufficient extent has been thus drawn through, the end of the wire is fastened to a cylinder to which the power is applied, and the wire coiled upon it as it comes through the plate. The new wire thus drawn is very stiff and hard, and requires annealing prior to the next drawing process. When annealed it is put into a vessel containing an acid liquor, and then scoured bright before it is passed through a second or smaller hole, in which the operation is repeated as many times as may be found necessary to reduce it to the size required,—annealing, treating with acid, and scouring, at every succeeding operation. It is said, that in order to heat this acid liquor, at an eminent manufactory, some ingots of brass which were at hand were heated red hot and quenched in it. It was afterwards found that the iron wire treated with this acid liquor, was covered with a thin film of copper, (derived from a slight solution of the heated ingot to the acid,) and that the wire was in consequence drawn through the plates with much greater facility than usual, the copper evidently acting as a lubrication to decrease the attrition between the wire and the draw-plate. In consequence of this accidental discovery, the practice has been since continued at the manufactory, of employing a weak solution of copper in the acid liquor used in iron and steel wire-drawing. The slight coat of copper is got rid of in the last annealing process.

To produce a perfect and durable wire-drawing plate, is a work of considerable art; and British skill has in this respect been long surpassed by the French, from whom all our best "draw-plates" are obtained. The process by which our ingenious neighbours attain their superiority, must therefore be of sufficient importance to our countrymen, to entitle it to a place in our work. In vol. xv. of *Les Arts et Métiers* is the following account of the process, by M. Du. Hamel.

"A band of iron is forged, of two inches broad, and one inch thick. This is prepared at the great forge. About a foot in length is cut off, and heated to redness in a fire of charcoal. It is then beaten on one side with a hammer, so as to work all the surface into furrows or grooves, in order that it may retain the substance called the *potin*, which is to be welded upon one side of the iron, to form the hard matter on which the holes are to be pierced. This *potin* is nothing but fragments of old cast-iron pots; but those pots which have been worn out by the continued action of the fire, are not good; the fragments of a new pot, which has not been in the fire, are better.

"The workman breaks these pieces of pots on his anvil, and mixes the pieces with charcoal of white wood. He put this in the forge, and heats it till it is melted into a sort of paste; and to purify it, he repeats the fusion ten or twelve times, and each time he takes it with the tongs to dip it in water." M. Du Hamel says, this is to render the matter more easy to break into pieces.

"By these repeated fusions with charcoal, the cast iron is changed, and its qualities approach those of steel, but far from becoming brittle, it will yield to the blows of the hammer, and to the punch, which is used to enlarge the holes. The bar of iron which is to make the draw-plate, is covered with a layer of pieces of the *potin*, or cast iron thus prepared. It is applied on the side which is furrowed, and should occupy about half an inch in thickness. The whole is then wrapped up in a coarse cloth, which has been dipped in clay and water, mixed up as thick as cream, and is put into the forge. The *potin* is more fusible than the forged iron, so that it will melt. The plate is withdrawn from the fire occasionally, and hammered very gently upon the *potin*, to weld, and in some measure amalgamate it with the iron, which cannot be done at once; but it must be repeatedly heated and worked, until the *potin* fixes to the iron. The workman then throws dry powdered clay upon it, in order, they say, to soften the *potin*.

"The union being complete, the plate is again heated, and forged by two workmen, who draw out the plate of one foot to a length of two feet, and give it the

form it is to have. It is well known, that cast iron cannot be worked at the forge without breaking under the hammer; but in the present instance, it is alloyed with the iron-bar, and is drawn out with it. It has also acquired new properties by the repeated fusions with charcoal.

"The holes are next pierced whilst the plate is hot. This is done with a well-pointed punch of German steel, applied on that side of the plate which is the iron-bar. It requires four heats in the fire to punch the holes, and every turn a finer punch is employed, so as to make a taper hole. The makers of draw-plates do not pierce the holes quite through, but leave it to the wire-drawers to do it themselves when the plate is cold, with sharp punches, and then they open the hole to the size they desire; and although this potin is of a very hard substance, the size of the hole may be reduced by gentle blows with a hard hammer, on the flat surface of the plate round the hole.

"A great many holes are made in the same plate; and it is important that they should diminish in size by very imperceptible gradations; so that the workman can always choose a hole suitable for the wire he is to draw, without being obliged to reduce it too much at once."

The next considerable wire manufactory in France, and probably in the world, is that of the Messrs. Mouchel, situated at L'Aigle, in the department of L'Orne. It furnishes annually in cards, for wool-combing only, 100,000 quintals of iron-wire = 10 millions of pounds! The whole of this is not required for home consumption, but is exported to Spain, Portugal, Italy, and other countries. As the excellence of their products is in a great measure attributable to the perfection of their draw-plates, we shall here add the process of preparing them, as described by the Messrs. Mouchel, which differs from that previously explained.

"Several pieces of iron are disposed in the furnace, in the form of a box without a lid, their weight being according to the use for which they are intended to be made. The workman fills each of these boxes with cast steel, and having covered it over with a luting of clay, it is exposed to a fierce fire until the steel be melted. His art consists in seizing the proper moment to withdraw the plate from the fire; he raises the luting, and blows on it through a tube, in order to drive off all heterogeneous parts, and then amalgamates it with the iron by light blows; after it is cool, he replaces it at the fire, where the fusion again takes place, but to a less degree than before; he afterwards works the steel with light blows of the hammer, to purify and solder it with the iron. This operation is repeated from seven to ten times, according to its quality, which renders it more or less difficult to manage. During this process, a crust forms on the steel, which is detached from it the fifth time of its exposure to the fire, because this crust is composed of an oxidated steel, of an inferior quality. It sometimes happens that two, and even three, of these crusts are formed of about two millimetres, or one-sixteenth of an inch, in thickness, which must also be removed.

"After all these different fusions, the plate is beaten by a hammer wetted with water, and the proper length, breadth, and thickness, are given to it. When thus prepared, the plates are heated again, in order to be pierced with holes by punches of a conical form; the operation is repeated five or six times, and the punches used each time, are progressively smaller. It is of importance that the plate never be heated beyond a cherry-red, because if it receives a higher degree of heat, the steel undergoes an unfavourable change. The plates, when finished, present a very hard material, which nevertheless will yield to the strokes of the punches and hammer, which they require when the holes become too much enlarged by the frequent passing of the wire through them.

"When the plates have been repaired several times, they acquire a degree of hardness which renders it necessary to anneal them, especially when they pass from one size to another; sometimes they do not acquire the proper quality until they have been annealed several times. Notwithstanding all the precautions which are taken in preparing the plates, the steel still varies a little in hardness, and according to this variation they should be employed for drawing either steel or iron-wire; and if the workman who proves them finds that they

are too soft for either the steel or iron, they are put aside, to be used by the brass-wire drawers.

"A plate that is best adapted for drawing of steel wire is often unfit for the iron; for the long pieces of this latter metal will become smaller at the extremity than at the beginning, because the wire, as it is drawn through the plate, is insensibly heated, and the adhering parts are swelled, consequently pressed and reduced in size towards the latter end. The plates that are fit for brass are often too soft for iron, and the effect resulting is the reverse of that produced by a plate that is too hard.

"The smallest plates which Messrs. Mouchel use are at the least two centimetres, or eight-tenths of an inch, in thickness, so that the holes can be made sufficiently deep; for when they are of a less thickness they will seize the wire too suddenly, and injure it.

"This inconvenience is much felt in manufactories where they continue to use the plates for too long a time, as they become exceedingly thin after frequent repairs. One of Messrs. Mouchel's large plates reduces 1,400 kilogrammes (3,080 lbs. avoirdupois) from the largest size of wire to No. 6, which is of the thickness of a knitting-needle; 400 kilogrammes (880 lbs.) of this number are afterwards reduced in one single small plate, to No. 24, which is carding-wire; and to finish them, they are passed through twelve times successively. Wires are frequently drawn so fine as to be wrought along with other threads of silk, wool, or hemp; and thus they become a considerable article in the manufacture."

"Dr. Wollaston, in 1813, communicated to the Royal Society, the result of his experiments in drawing wire. Having required some fine wire for telescopes, and remembering that Muschenbrock mentioned wire 500 feet of which weighed only a single grain, he determined to try the experiment, although no method of making such fine wire had ever yet been published. With this view, he took a rod of silver, drilled a hole through it only one-tenth its diameter, filled this hole with gold, and succeeded in drawing it into wire till it did not exceed the three or four-thousandth part of an inch, and could have thus drawn it to the greatest fineness perceptible by the senses. Drilling the silver he found very troublesome, and determined to try to draw platina wire, as that metal would bear the silver to be cast round it. In this he succeeded with greater ease, drew the platina to any fineness, and plunged the silver in heated nitric acid, which dissolved it, and left the gold or platina wire perfect."

In 1819 a patent was taken out by Mr. Brockedon, for mounting the wire-drawing plates with diamonds, sapphires, rubies, and other hard gems; in these conical holes were to be drilled, with their extremities rounded off, which were afterwards to be polished by the processes known to lapidaries. By these means it was expected the wire might be more equally and cylindrically drawn, owing to the impenetrable hardness of the gems, which would not sensibly wear from the same cause.

As the repeated annealings to which iron wire is subjected, to cause it to yield to the resistance of the draw-plate, would be destructive of the property from which steel derives its utility, steel wire, therefore, during the process of annealing, is surrounded with charcoal-dust from which carbon is reabsorbed in the furnace; thus the metal is rendered very soft and yielding, without losing its steel property.

Among the curious and important "results of machinery" might be mentioned the manufacture and application of steel wire to the making of the hair-springs of watches. "A pound of crude iron costs one half-penny; it is converted into steel; that steel is made into watch-springs; every one of which," it is said, "is sold for half a guinea, and weighs only the tenth of a grain, after deducting for waste, there are in the pound weight about 7,000 grains; it therefore affords steel for 70,000 watch-springs, the value of which, at half a guinea each, is 35,000 guineas!" Now as there are 504 half-pence in a guinea, the pound of crude iron has increased 17,640,000 times in value.

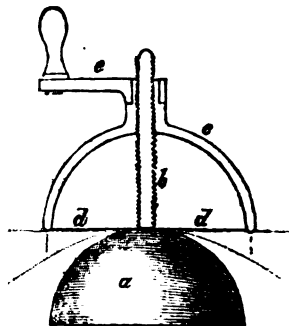
The looms employed for weaving wire-cloth are not essentially different to the looms employed for weaving other filaments, and several patents have been

taken out for modifications of the power-loom, to adapt it to weaving of wire; which are described in the *Repertory and Journal of Patent Inventions*.

The application of wire-gauze to the manufacture of baskets, dish-covers, and a great variety of useful articles, took place about ten years ago, under a patent granted to Mr. Gosset, of the Haymarket, London, who brought the invention from abroad. The annexed cut is explanatory of the process of conversion.

The operation is exceedingly simple, being performed entirely by forcing the wire-gauze between moulds of the required shape, by the power of a screw press, which causes the figure or pattern thus given to it, to be permanently retained after the article has been withdrawn from the mould. We extract the following from the specification before us:—

“It consists of a pattern or block *a*, of metal, wood, or other suitable material, which is formed on the exterior surface to the desired shape and size of the article intended to be produced. The block *a* has a screw *b*, projecting up from the top or crown thereof; *c* represents a pattern or mould made in like manner, of any suitable material; the interior surface of this mould is formed to the desired shape of the article intended to be produced, and has an aperture made in the crown thereof, so as to be capable of passing over the screw *b*, and thus permit the mould *c* to come down over the block *a*, as shown in the figure.



The manner of using the machine is as follows: the metallic wire-gauze or other material, (which is intended to be shaped,) has a hole made through it, and is passed over the screw *b*, so as to rest upon the crown of the block *a*, as seen at *d d*. In this situation, the upper mould *b* is placed upon the said metal or gauze-wire, with the screw passing through its aperture, as aforesaid; and the nut or handle *c* is put on its place, and is turned down upon the screw *b*, by which means it presses down the upper mould *c* upon the metallic wire-gauze, or other material, and thereby forces it into the cavity or space between the block *a* and mould *c*, so as to give it the desired shape of the article required. The apparatus is then inverted, and placed upon a bench, or other convenient support, with the screw *b* projecting downwards; and a ring or hoop of tinued wire, or other suitable material, is inserted within the lower edge of the article, and is soldered, or otherwise securely fixed, to the wire-gauze or other material, of which the article is formed. The nut *e* may then be screwed to the back of the screw *b*, and the mould and block may be separated, so as to take out the article, which will be found to retain the pattern or shape given to it by the said mould or machinery. After this, the portions of the metallic wire-gauze, or other material, which may happen to project beyond the edges of the aforesaid hoop or ring, are to be cut off all round evenly, and a small ornamental band of metal, or other material, may be soldered or otherwise fixed upon the exterior edge of the article, so as partly to conceal the interior hoop or ring, and render the whole neat; and then, to finish and complete it, a small nut or button may be fixed through the aperture in the crown, for the convenience of carrying the articles by. Articles of this description will be found very serviceable for covering up delicate commodities, or articles of food, to preserve them from the effects of flies, and for a great variety of useful purposes.”

The specification then proceeds to describe another slight variation from the above method, for “producing articles of such a description as will not admit of a hole or aperture being made in them.” For this purpose, the actuating screw is made to pass through a fixed nut in an iron frame, the end of the screw entering the flat or lower side of the block, which is forced into the cavity of the mould, with the wire-gauze between them. The patentee concludes by claiming as his invention, “the forming or producing of articles of various shapes,

patterns, and sizes, out of metallic wire-gauze, or other materials, as aforesaid, by the operation of pressing or forcing the said metallic wire-gauze, or other materials, into moulds or shapes of the desired form of the article intended to be produced; the articles so formed or produced from the metallic wire-gauze, or other material, being caused to retain or preserve the shape or pattern which may have been given to them, by means of one or more hoops or rings, which are secured by solder or otherwise to the edges of the said articles, during the time they remain within the mould."

**WOOD.** The ligneous matter forming the substance of trees. It is, in most cases, possessed of colour, taste, and smell, from the presence of extractive matter, mucilage, resin, or essential oil; and it is only when these have been extracted by water and alcohol, that wood can, as a chemical principle, be regarded as pure. In this state, it is insoluble in water: it is equally insoluble in alcohol, and hence it forms the residuum, when any of the solid parts of plants have been acted on by these fluids. From the action of the air, if dry, it does not appear to suffer any change; but, when humid, it is gradually decomposed, and passes through many intermediate states, to that of a black mould, consisting principally of carbon. The oxygen of the atmospheric air is, during this change, absorbed, and carbonic acid formed with a portion of water; and the latter, being derived from the combination of the oxygen, leaves carbon predominant. When the air is entirely excluded, wood decomposes with extreme slowness, even though humid; as, for example, when it is buried in the earth, the alkalies act on wood, and stain it of a dark colour: with the assistance of heat, they soften, and partly dissolve and decompose it. The stronger acids act on it. Sulphuric acid carbonizes it, rendering it speedily black and soft. Nitric acid gives it a yellow tinge, and, when acted on in large quantity, disengages nitrogen gas, and converts it into oxalic acid, with small quantities of malic and acetic acids.

Wood suffers decomposition from heat; a large quantity of an acid liquor distils over, with a portion of empyreumatic oil. Carburetted hydrogen and carbonic acid gases are disengaged, and a portion of ammonia is produced, which is neutralized by the acid. A charcoal remains, which retains the figure and even texture of the wood. The acid procured in this process, was observed to be similar to vinegar, and was afterwards regarded as a peculiar one, and named pyro-ligneous acid; but the researches of Fourcroy and Vauquelin proved that it is only acetic acid, with an impregnation of empyreumatic oil.

When air is admitted, and the heat raised to ignition, wood burns. Its combustion at first, gives much light, from the formation and extrication of carburetted hydrogen: this soon ceases, and the charcoal remains, which burns with its usual red light. The products of the combustion are principally carbonic acid and water. Nitrogen appears to be a constituent principle of wood; ammonia, therefore, is also evolved, and accordingly, an ammoniacal salt is found in the soot of wood.

The colouring of wood is effected by a variety of processes. Stains do not lie, like paints, upon the surface of wood, but sink more or less into its substance. Hence, the material which has been stained, exhibits its natural grain and hardness: and it must be remembered that, if the wood be not white, the colour taken will be a compound of that of the wood and the stain. The dyeing woods employed, are in small chips or raspings.

The woods which have been stained are afterwards rubbed up with rushes, then with a cloth, dipped in a solution of bees' wax in spirits of turpentine; and afterwards rubbed with a woollen cloth alone. When the stain is intended to be very deep, the pieces should be boiled in the staining liquor, and not merely brushed over. To stain wood red, take two ounces of Brazil wood, and two ounces of potash; mix them with a quart of water, and let the composition stand in a warm place for several days, stirring it occasionally. With this liquor, made boiling hot, brush over the wood till the desired depth of colour is obtained: then with another brush, brush over the wood while yet wet, with a solution of alum, in the proportion of two ounces of alum to a quart of water. For a pink or rose red, use double the quantity of potash. For a less bright red, dissolve

an ounce of dragon's blood in a pint of spirits of wine, and brush over the wood with the tincture till the stain appear to be as strong as is desired; but this is, in fact, rather lacquering than staining. For a pink or rose red, add to a gallon of the above infusion of Brazil wood two additional ounces of the pearl-ashes, and use it as was before directed; but it is necessary, in this case, to brush the wood over with the alum-water. By increasing the proportion of pearl-ashes, the red may be rendered yet paler; but it is proper, when more than this quantity is added, to make the alum-water stronger. To stain wood green, dissolve verdigris in vinegar, or crystals of verdigris in water, and brush over the wood with the hot solution. To stain wood blue, dissolve copper in diluted nitric acid, and brush it while hot several times over the wood; then make a solution of pearl-ashes, in the proportion of two ounces to a pint of water, and brush over the stain made with the solution by copper till the colour be perfectly blue. The green stain, made as above with verdigris, may be changed to a blue, by the solution of pearl-ashes. The sulphate of indigo, which may be had, ready prepared, of the dyers, will, when diluted with water, make a blue stain. To stain wood black, brush the wood several times with a hot decoction of logwood, then several times with common ink. To make a very fine black, brush over the wood with a solution of copper in nitric acid as for blue, and afterwards with logwood, till all the greenness of the copper solution is gone. To stain wood purple, take one ounce of logwood and two drachms of Brazil wood; boil them together in a quart of water, over a moderate fire. When one half of the fluid is evaporated, strain the decoction, and brush it several times over the wood. After the wood is dry, brush it over with a solution of a drachm of pearl-ashes in a pint of water.

**WOOL.** The long, soft, curly hair, which covers the skin of sheep, and some other ruminating animals. Wool resembles hair in many respects; besides its fineness, which constitutes an obvious difference, there are other particulars which may serve also to distinguish them from one another. Wool, like the hair of horses, cattle, and most other animals, completes its growth in a year, and then falls off as hair does, and is succeeded by a fresh crop. It differs from hair, however, in the uniformity of its growth, and the regularity of its shedding; the whole crop springs up at once, and the whole falls off at once, if not previously shorn, which leaves the animal covered with a short coat of young wool, which in its turn undergoes similar mutations. Berthelot has shown that the caustic alkaline leys dissolve wool entirely, and that the acids precipitate it from this solution. The facts elicited by chemical research explain all the phenomena, and all the properties which wool presents in the frequent and advantageous uses to which it is applied. While the wool remains in the state in which it is shorn from the sheep's back, it is called a fleece. Each fleece consists of wool of different qualities and degrees of fineness, which the dealers sort and sell in packs at different rates to the wool-comber. The finest wool grows on and about the head of the sheep, and the coarsest about the tail; the longest on the flanks, and the shortest on the head and some parts of the belly. Wool that is shorn when the sheep is living, is called fleece wool, and that which is pulled off the dead animal is called skin-wool. Wool, in the state in which it is taken from the sheep, is always mixed with a great deal of dirt and foulness of different kinds, and in particular is strongly imbued with a natural strong-smelling grease. These impurities are got rid of by washing, fulling, and combing, by which the wool is rendered remarkably white, soft, clean, light, and springy. When boiled in water for several hours, it is not altered in any sensible degree, nor does the water acquire any impregnation.

The wool intended for the manufacture of stuffs is brought into a state adapted for the making of worsted by the wool-comber; who, having cleared it from all impurities, and well washed it with soap and water, he puts one end of a certain quantity on a fixed hook, and the other on a movable hook, which he turns round with a handle, till all the moisture is forced out. It is then thrown lightly into a basket. The wool is next spread out in layers, and a few drops of oil are scattered on each; which are packed in a bin underneath a bench where the comber sits at work. At the back of the bench is another bin, to

contain the *noyles*, as it is called, which is that part of the wool that is left in the wool after the sliver is drawn out. The comb consists of three rows of highly-tempered and polished steel, fixed in a long handle of wood, and set parallel to one another. Each comber has two combs, which he fills with wool and then works them together, till the wool on each is perfectly fine, and fit to draw out in slivers. The best combs of this kind are said to be manufactured at Halifax, in Yorkshire. In using these combs the workman has a pot made of clay, with holes in its side, in which he heats them to a certain temperature before it can be made readily to pass through the wool. Each comb-pot is made to hold eight combs, so that four men usually work in one compartment of the shop, round a single pot. When the wool has been sufficiently worked on the combs, the workman places one comb and then the other on a fixed spike, at a proper height for him to draw it out as he stands. The wool thus drawn out is called a sliver, and is from five to six or seven feet in length. Such is the mode of wool-combing by hand, but several patents have been taken out for performing the same operation by machinery; the first of which was introduced by the ingenious Dr. Cartwright, in 1790, and wool-combing by machinery has now almost wholly superseded the work by hand, owing to the economy of labour and material which it effects.

The manufacture of wool is divided into two distinct classes,—long wool, or worsted-spinning, and short wool, or woollen-yarn-spinning. We have already described, under *COTTON*, the process of spinning that material: it will be readily conceived that the spinning of other fibrous matter does not very essentially differ therefrom, but that it merely requires certain modifications in the apparatus to adapt it to the difference of fibre in the staple commodity. In spinning *worsted* by hand, the portion of wool plucked from the sliver was placed across the fingers of the left hand, and from the thick part of it the fibres were drawn and twisted as the hand was withdrawn from the end of the spindle, to which it had been previously attached. The revolution of the wheel, effected by the right hand, conveyed by a band to the wheel, or pulley on the spindle, produced the requisite to give firmness to the thread; and by a very gentle motion of the same wheel, the thread being brought nearly perpendicular to the spindle, it was wound upon the spindle to form the cop. From this it was transferred to the reel, and became a hank, of a definite length, but varying in weight with the thickness of the thread. In this state it was transferred to the manufacturer, to be converted into shalloons, bombazin, or whatever other fabric *worsted* is applicable to.

"A few years after the introduction of cotton machinery," (says the author of the *Operative Mechanic*), "an obscure individual of the name of Hargraves, previously unknown as a mechanic, who had long been employed by Messrs. W. Birkbeck and Co. of Settle, in Yorkshire, in the management of a branch of the worsted manufactory, attempted to spin long wool by means of rollers. He constructed working models of the necessary preparing machinery, and of a spinning frame, by the assistance of persons accustomed to the construction of cotton machinery; and succeeded so completely, as soon to induce his employers to build a large mill for its application. By degrees his plans became known to the trade, and many large manufactories have subsequently been erected for this purpose. Contrary to the earlier anticipations on this subject, it has been found that mill-spun yarn answers better for the coarse as well as the finer fabrics, than that produced by the hand, which it has entirely superseded."

In spinning *worsted* by machinery, a sliver of wool is laid upon the drawing-frame, from whence it is conducted through several pairs of rollers, of which the operation of the first and last are the essential ones, the intermediate rollers moving with equal velocities, and serving merely to conduct the skin, which is received into a cylindrical can; three such skins being passed through another drawing-frame, and stretched in their progress, become fitted for roving,—the last step in the preparatory process. The spinning, which is the *combing* process, is effected by means of two pair of rollers moving with equal velocities, and intermediate auxiliaries.

In manufacturing short wool into *cloth*, it is first soaked in urine, and



frequently rinsed in clean water, which adapts it to the next operation,—that of carding. The carding engine for fine short wool is constructed with one main cylinder, having in lieu of the top cards used in jenny-spinning, numerous small rollers, lying and rolling upon its upper surface; it is used in place of a breaker engine, and is called a scribbler. The wool is delivered from a main cylinder to a doffer, and, being combed or doffed, is carried to another engine called the *carder*, which perfects the carding, and delivers it off, by means of grooved mahogany rollers, in a row or rowan, as in jenny-spinning. If the wool is of a coarse description, such as is formed into yarn, for the manufacture of coarse cloths, more carding is required.

The *scribble* engine has three distinct parts or cylinders in one frame. The first part consists of the first main cylinder with its top rollers, and is called the *breast*; this delivers the wool to the second main cylinder, which with its top rollers is called the first part; this delivers it up to a small intervening cylinder called the *tween doffer*, which carries it to the third main cylinder, which, with its top rollers, is called the second part; from hence it goes to the last doffer cylinder, from which it is combed by a doffing-plate, and finally carried by hand to a carding engine; by which the wool is formed into separate and smooth rolls of twenty-eight inches long, and half an inch thick, which are immediately taken by boys, and attached to the spindles of the roving or slubbing machine. This machine draws out the wool into large and slightly-twisted threads, and winds it into balls ready for spinning. By the spinning-jenny the threads are twisted, and drawn to a proper degree of size and strength, and are then reeled into skeins and prepared for the loom. The stronger sort intended for the woof is wound on spools, or quills, which are tubes of such a size and shape as to be easily placed in the hollow of a shuttle. That designed for the warp is wound on large wooden bobbins, from which it is by the warping-bar conveniently arranged for the chain or warp of the piece.

A patent was taken out a few years since, by Mr. Hadden, for improvement in preparing wool, and also for roving and spinning it in a heated state. The patentee observes, that various methods may be adopted for supplying heat to wool, during all or either of the three processes of preparing, roving, and spinning. The method which Mr. Hadden has adopted is the introduction of cast-iron heaters into the retaining rollers used for these processes, observing that he always uses three rollers or cylinders together, and by leading the wool over half the circumference of the upper two rollers, charged within with the heaters above mentioned, he thoroughly warms the wool, without retarding the progress of the other processes.

The mode of applying the heaters is by making the retaining cylinders below, and by introducing a cylindrical heater into each retaining cylinder. These heaters are made exactly to fit the interior of the retaining cylinders, the axes of which pass through a channel for that purpose in the middle of the heater. It is to be observed that the heaters may be put within the driving cylinders with equal effect.

The qualities which distinguish woollen cloths from all other manufactures, and renders them particularly suitable for northern climates, are the compactness and density they acquire from the operation of fulling. The cloth is sprinkled over with a liquor prepared from oil of olive soap dissolved in hot water, and then laid in the mill-trough, where it is pounded with heavy wooden hammers. By this process a cloth 40 yards long, and 100 inches wide, is reduced to 30 yards long, and 60 inches wide. During the operation the cloth is taken from the trough, the wrinkles smoothed, and more soap added. The property of becoming thicker by compression is peculiar to woollen cloths. It is said that the fibres of the wool are thickly set with jagged protuberances, which it is supposed catch hold of each other when pressed together, and thus become inextricably united, so that the cloth when cut does not unravel like other cloth. After milling, the cloth is scoured with a preparation of *starch*, earth and bullock's galls, till perfectly free from soap, and then taken to the mill-worker to be dressed. This operation is performed by first drawing straight placing in one direction, by means of wire cards and teazles, all the fibres

wool that can be brought to the surface, and then shearing them as close as may be practicable without laying the threads of the cloth bare. The instruments employed in this process were formerly worked by hand; but this operation is now performed by machinery, in a very superior manner to any manual efforts, and at a much less expense. When this process is completed, the cloth is taken to the rack, where it is strained so as to bring it to an even breadth throughout its length, and it is then sheared again, to render it perfectly level and uniform. All the little bits of straw or lint that may adhere to it are now picked out, and any holes that may be discovered carefully fine-drawn. The cloth is next laid in a press with a sheet of glazed paper between every fold; these are covered by thin boards, and hot iron plates laid thereon, by which a gloss is communicated to the cloth. After the press has been screwed down for a sufficient time, the pressure is removed, and the cloth taken out and packed for sale.—We have thus given an outline of the process of manufacturing of woollen cloth, as it was generally conducted a few years ago; but the rapid progress of mechanical invention during a very brief period, has made so extensive a change in the apparatus and processes, as to preclude the possibility of a detailed description within the prescribed limits of this work; we shall, however, before closing this article, notice two or three recent patents, the leading objects of which are to give to woollen cloths that silky softness and gloss, for which the best finished modern fabrics are so distinguished.

Mr. Fussell's mode of producing the lustre upon cloths, as stated in the specification, is in substance as follows.—After the cloth has undergone the usual dressing in the gig-mill, and hand-brushing, it is to be tightly wound upon a cylindrical roller, the extremities of which are to have deep grooves made round their peripheries, that will permit the list on the edges of the cloth to sink into them, and by these means preserve the cloth in a smooth and level surface. The roller of cloth so prepared is to be set on end for some time, to permit the water to drain off; it is then to be placed in either an open vessel over a steam boiler, and exposed to the action of the steam for three hours, or it may be placed in a close vessel into which the vapour is to be allowed to pass while it is made to revolve. The temperature of the steam proper to be employed depends upon the colour of the cloth, and the degree of lustre required; but in general the heat should be somewhat less than that of boiling water.

Mr. James Dutton's patent method consists in pressing the cloth at the time it is being heated. His press for this purpose has one fixed, broad, and flat surface or table, equal to the whole width of the cloth, and of suitable dimensions in the other direction to receive about a yard of the cloth in length at a time, to receive the pressure; which is effected by a flat metal plate, or platten, of corresponding dimensions, made to rise and fall, and to be operated upon by powerful leverage, or hydrostatic pressure. To render the effect of this process permanent, heat and humidity are employed in conjunction with it. For this purpose a steam or hot-water chamber is formed in the table of the press, and the cloth is brought under the operation in its wet state, the pressure being continued upon each successive portion of cloth, for a certain number of minutes (varying with the "dress" required, and other circumstances).

It is desirable, in the process of roughing or raising the pile upon woollen cloth, that the action of the teazles should be made to deviate from straight lines on the surface of the cloth. The patented improvement of Mr. Oldland, dated July 1830, for this object, consists in a horizontal revolving teasele frame, furnished on its under side with teazles, wire-cards, brushes, or other materials used in dressing or raising the pile of the cloth. The revolving teazles are put in motion by a band fixed to the revolving spindle; and as the cloth is brought under the teazles by conducting rollers of the usual construction, it is pressed up against the teazles by a supporter covered with some elastic material, only on that side of the centre of motion of the revolving teasele which moves from the middle towards the selvage of the cloth, the teasele frame reaching only halfway across it; and one being placed on each side, moving in different directions, the pile will be raised in all cases from the centre towards both selvages of the piece of cloth, though from the nature of the action of this machine it is evident that its operation

on the cloth can in no case be rectilinear, and that by the end motion of the cloth the lines of action will be continually crossing each other at very acute angles. In the same year another patent was taken by Mr. Papps, for the same object, in which the principle and operation are the same, though the details vary a little. A third patent for the same object was granted on the same day as the last mentioned, to Mr. Ferrabee, who raises the pile in a different direction, namely, from the middle sloping to the sides; for this purpose he employs two series of teazles; each series is attached to an endless chain which passes round two cylinders by which it is put in motion. Two of the cylinders which support and give motion to the teazle chains are placed with their axes extending along the middle of the piece of cloth to be operated upon, and the other two cylinders are placed near the selvages of the cloth, with their axes parallel thereto. Each pair of cylinders is made to turn in a direction to raise the pile of the cloth from the middle towards the selvages, at right angles to them when the cloth is at rest; but when an end motion is given to the cloth, which is effected by means of two cylinders placed at right angles to the teazle cylinders, the pile is raised in an angular direction, sloping from the middle towards the selvages. The angle of the work may be varied at pleasure, by varying the relative speeds of the different sets of cylinders.

The processes employed in dyeing woollen cloth differ considerably from those used in silk and cotton. The oil is first removed by the operations of the fulling-mill, where it is beaten with large beetles in troughs of water, mixed with fuller's-earth; and when thoroughly cleansed it is ready for dyeing. The only colours used in dyeing wool *blue*, are woad and indigo, which are both substantive colours, that is, they are permanent without requiring a mordant. Quatremere recommends the following mode of preparing a blue vat:—Into a vat about seven and a half feet deep, and five and a half broad, are thrown two balls of woad, weighing together about 400 lbs., first breaking them; thirty pounds of weld are boiled in a copper for three hours, in a sufficient quantity of water to fill the vat; when this decoction is made, twenty pounds of madder and a basket full of bran are added, and it is boiled half an hour longer. This bath is cooled with twenty buckets of water; and, after it is settled, the weld is taken out, and it is poured into the vat; all the time it is running in, and for a quarter of an hour after, it is to be stirred with a rake. The vat is then covered up very hot, and left to stand six hours, when it is raked again for half an hour, and this operation is repeated every three hours. When blue veins appear on the surface of the vat, eight or nine pounds of quick lime are thrown in. Immediately after the lime, or along with it, the indigo is put into the vat, being first ground fine in a mill, with the least possible quantity of water (it is now usually ground dry.) When it is diluted to a semi-fluid consistence, it is drawn off at the lower part of the mill, and thrown thus into the vat. The quantity of indigo depends upon the shade of colour required. From ten to thirty pounds must therefore be put to the vat now described, according to the occasion.

If, on striking the vat with the rake, a fine blue scum arises, it is fit for use, after being stirred twice with the rake in six hours, to mix the ingredients. Great care should be taken not to expose the vat to the air, except when stirring it. As soon as that operation is over, the vat is covered with a wooden lid, on which are spread thick cloths, to retain the heat as much as possible. Notwithstanding this care, the heat is so much diminished at the end of eight or ten days, that the liquor must be re-heated, by pouring the greater part of it into a copper over a large fire; when it is hot enough, it is returned into the vat, and covered as before.

This vat is liable to two inconveniences: first, it runs sometimes into the putrefactive fermentation, which is known by the fetid odour it exhales, and by the reddish colour it assumes. This accident is remedied by adding more lime. The vat is then raked: after two hours, lime is put in, the raking performed again, and these operations are repeated till the vat is recovered; secondly, if too much lime is added, the necessary fermentation is retarded; this is remedied by putting in more bran or madder, or a basket or two of fresh woad.

When cloth is to be dyed, the vat is raked two hours before the operation ; and to prevent it from coming in contact with the sediment, which would cause inequalities in the colour, a kind of lattice of large cords, called a cross, is introduced ; when unmanufactured wool is to be dyed, a net with small meshes is placed over this. The wool or cloth, being thoroughly wetted with lukewarm water, is pressed out, and dipped into the vat, where it is moved about a longer or shorter time, according as the colour is intended to be more or less deep, taking it out occasionally to expose it to the air, the action of which is necessary to change the green colour, given the stuff by the bath, to a blue. Woollen and cloth dyed in this manner ought to be carefully washed, to carry off the loose colouring matter ; and, when they are of a deep hue, soap should be used, as it will only cleanse and not injure the colour. The more perfectly the wool has been scoured, the better it will receive the dye.

A vat which contains no woad, is called an indigo-vat. For this vat, the indigo is rendered soluble in water by potash instead of lime ; a copper vessel is used, and six pounds of potash, twelve ounces of madder, and six pounds of bran, are boiled with every 120 gallons of water ; six pounds of finely-ground indigo are then added, and, after carefully raking it, the vat is covered, and a slow fire kept round it. Twelve hours afterwards, it is to be raked a second time, and this operation is to be repeated at similar intervals of time, till the dye becomes blue, which will generally happen in forty-eight hours. If the bath be properly managed, it will be of a green colour, covered with coppery scales, and a fine blue scum.

The dye called *Saxon blue* is made with the solution of indigo in sulphuric acid. Take four parts of sulphuric acid, and pour them on one part of indigo, in fine powder ; let the mixture be stirred for some time, and after it has stood twenty-four hours, add one part of dry potash ; let the whole be again well stirred, and after it has stood a day and a night, add gradually more or less water. The cloth to be dyed, must be prepared with tartar and alum, and more or less indigo must be put into the bath, according to the shade required. For deep shades, also, the cloth must be passed several times through the bath ; light shades may be dyed after deep ones, but they will not have the lustre given by a fresh bath.

Reds are a very important class of colours, and are furnished by a great number of substances. They all depend, either for their fixedness or beauty, upon the use of mordants ; the principal of them are kermes, cochineal, archil, madder, carthamus, and Brazil-wood. Pewter boilers, or well-tinned copper, must be used in preparing all red baths.

The shades of red are usually distinguished into three classes ; namely, the madder red, crimson, and scarlet. Madder is employed for coarse goods. It gives out its colour to water ; and the bath prepared with it is not made hotter than what the hand can bear, until the wool has been in it about an hour, when it may be boiled for a few minutes just before the wool is taken out. It may be used in the proportion of one-third or one-fourth of the wool dyed. Cloths are prepared for the madder-bath, by boiling them for two or three hours in a solution of alum and tartar ; after having been taken out of which, they are left to drain for a few days in a cool place before they are dyed. The use of archil gives a fine but transient bloom to the madder dye. Archil and Brazil-wood, from their perishableness, are seldom used to wool, except in this way, as auxiliaries.

When sulphate of copper is employed as the mordant, madder dyes a clear brown, inclining to yellow. Tin brightens its colour, but not materially.

Kermes has not been much used since the art of brightening cochineal with tin was discovered, as it has not so fine a bloom as the latter dye, though it possesses greater durability. Kermes imparts its colour to water ; and the quantity of it used, is, for a full colour, at least three-fourths of the weight of the wool employed. The wool is put in at the first boiling, after having been previously prepared by boiling it for half an hour in water with bran, and afterwards two hours in another bath, with one-tenth of tartar dissolved in sour water, and then leaving it for a few days in a linen bag.

The red colour of the flowers of *carthamus* is extracted by a weak alkaline ley, and precipitated by lemon juice or sulphuric acid, but is chiefly used for silk and cotton. The precipitate is used in dyeing, and is called *safflower* or *bastard saffron*.

A crimson colour, inclining to violet, is the natural colour of cochineal, which yields most of its colouring matter to water, and, by the addition of a little alkali or tartar, the whole of it is extracted. To dye crimson by a single process, a solution of two ounces and a half of alum, and an ounce and a half of tartar, with an ounce of cochineal, is employed for every pound of stuff. A little nitromuriate of tin must be added for a fine crimson. Archil gives to crimsons that fine dark shade which is called bloom, but this soon disappears, by exposure to the air and light. For pale crimsons, the quantity of cochineal is reduced, and madder substituted.

Dr. Bancroft first suggested that scarlet was a compound of crimson and yellow, and he founded upon this idea, a more economical mode of producing it than had previously been used. He gives the following directions for dyeing scarlet:—One hundred pounds of cloth are to be put into a tin vessel, nearly filled with water, with which about eight pounds of the murio-sulphuric solution of tin have been previously mixed. The liquor is made to boil, and the cloth is turned through it by the winch, for a quarter of an hour, in the usual manner. The cloth is then taken out, and four pounds of cochineal, with two pounds and a half of quercitron bark in powder, put into the bath and well mixed. The cloth is then returned into the liquor, which is made to boil, and the operation is continued as usual, till the colour be duly raised, and the dyeing liquor exhausted, which will usually happen in about fifteen or twenty minutes, after which, the cloth may be taken out and rinsed. In this method, the labour and fuel necessary in the common process for the second bath are saved; the operation is finished in much less time; all the tartar will be saved, as well as two-thirds of the expense of the solvent for the tin, and at least one-fourth of the cochineal usually required; the colour, at the same time, will not be in any respect inferior to that produced in the ordinary way, at so much more trouble and expense, and it will even look better by candle-light than others.

By omitting the quercitron-bark, the above process will afford a rose-colour. Scarlet may be changed to crimson by boiling the cloth in a solution of alum; till the shade desired is obtained. Alkalies and earthy salts in general have the same effect as alum.

Yellow is a colour but rarely required in the dyeing of wool, yet, as it frequently forms the base of other colours, it may be proper to notice it. Weld fustic, and quercitron bark, furnish the best yellows: weld is a plant which is both cultivated and grows wild in this country; the stem is slender, and rises to the height of three or four feet; the entire plant is used in dyeing, and is gathered when it is ripe: the shortest and slenderest stems are the most esteemed. Fustic is the wood of a large West Indian tree. Quercitron grows in great abundance in North America, and is there called yellow oak; its bark is the only part used for dyeing.

The colours obtained from weld and quercitron both nearly resemble each other in shade, and also in durability, which is not great; but the bark containing the largest quantity of colouring matter is not only the most convenient to use, but upon the whole the cheapest. Dr. Bancroft has given the best directions for its use. He directs a deep and lively yellow to be thus prepared for wool:—Let the cloth be boiled for an hour or more, with about one-sixth of its weight of alum dissolved in a sufficient quantity of water; then plunge it without rinsing into a bath of warm water, containing in it as much quercitron bark as equals the weight of the alum employed as a mordant. The cloth is to be turned through the boiling liquid until it has acquired the intended colour. Then a quantity of clean powdered chalk, equal to the hundredth part of the weight of the cloth, is to be stirred in, and the operation is completed. The object which the dyer has in view is to give his stuffs a uniform and durable colour, at the same time that he entirely preserves their original texture. He therefore uses colours in solution, in order that their particles may apply them-

selves to the individual fibres of the stuff, according to their affinity for it. When, for example, a quantity of wool, freed from all impurity, is dipped into the solution of any colouring matter, if the fibres of the wool have a stronger attraction for the colouring matter than the water or other menstruum which holds that colour in solution, the colouring matter will leave its solvent, and apply itself to the wool, which will by that means be dyed; its fibres will have become covered with colouring matter; and if their attraction for it be so strong that the action of soap, air, and light, or other ordinary means of exposure, shall have no perceptible effect in decomposing the combination, or in other words, of injuring its tinge, the colour is said to be permanent; so that dyeing is in fact a chemical process, and the application of both animal and vegetable bodies depends on their chemical affinities.

**WRITING.** The art of communicating our ideas to others by means of inscribed signs or characters. Amongst the various arts which have from time to time contributed to the improvement and advancement of society, there is, perhaps, none which, in point of utility and excellence, will at all admit of comparison with the art of writing. Yet because this art may now be acquired by every body, it fails to attract the attention and command the admiration it so well merits. How curious and beautiful soever a new discovery may be, let it once become common, and from that moment it ceases to be noticed; that which is within the grasp of every body is despised. The time was, when a man who could write was highly distinguished amongst his fellows; but the time is approaching, when a man who cannot write will be pointed out as a remarkable character.

In the first ages of the world, while society was in its infancy, mankind had clearly no other method of expressing their ideas in writing, than the simple one of making a figure of the shape of the object. And this method must have been long before their dispersion; for it has been found to exist amongst the most rude, as well as the most polished nations of the globe; situated too at such remote distances from each other as to preclude intercourse with the rest of mankind. This mode of writing seems the most natural, because the representation of sounds, which express the names of things, by certain characters or alphabets now so extensively in use, must necessarily require some previous concert between two parties, the one of whom suggests, and the other agrees, that a particular mark or form on paper, shall be the symbol for a particular sound. But if we suppose a savage separated from his friend, and wishing to communicate with him, without having had this previous consultation, and supposing that he has lent his distant acquaintance some articles of furniture, such as his bow and arrows, or his knife, which he is anxious to have returned, without the knowledge of his messenger, or being dependant upon his memory; it seems highly probable, that his first impulse would be to make a rude sketch of these articles, and transmit them to his friend. Were the latter an acute man, he would probably understand the allusion; and were he not intelligent enough for this purpose, it is clear he would not be sufficiently so to comprehend symbols that denote sounds. So that the simplicity of this mode of writing might suggest the probability of its being first resorted to, without alluding to the hieroglyphics yet remaining on the Egyptian tombs, which, from our want of acquaintance with the manners, customs, and general objects with which the Egyptians were conversant, are very difficult to decipher, if we may judge from the learning displayed in explaining them. In *Freycinet and Arago's Voyage* is given the drawing of a letter, written in this kind of language, from an inhabitant of the Caroline Islands to M. Martinez, which is perfectly intelligible. M. Martinez had commissioned a Tamor of Sathoual to send him some shells, promising in exchange a few pieces of iron. The captain gave him a sheet of paper, on which he sketched with a red pigment, first, in the middle of the top of the page, a small figure of a man with his arms extended horizontally, intended to represent the bearer of compliments; and underneath the man, the branch of a tree, as the type of peace and amity. On the left hand side were represented the forms of nine different shells the Carolinean had to send; and on the right hand side were delineated the objects he desired in exchange; namely, three large fishing-

hooks, four small ones, two axes, and two longer pieces of iron. The barter was accomplished to the satisfaction of both parties. This is, perhaps, as clear an instance as can be found, of the mode in which an unlettered people would endeavour to convey the expression of their wishes to their friends at a distance, and forms a striking contrast to the elegant though complicated process of our own method of writing.

The written language of the Chinese affords many proofs of its having originated in picture writing. This method of writing, of course, required considerable patience and skill to practise, and by common consent the characters or signs were from time to time simplified, so as to be expressed by much fewer lines. In Egypt, where the progress of the arts was greatly encouraged, means were discovered to substitute the original figures by very simple marks, by retaining only the most prominent peculiarities of the objects, and these, from their superior convenience and facility of execution, soon afterwards became universally adopted. Yet it may be readily conceived, that there remained many difficulties to overcome, by the great variety and intricacy of the figures. To simplify, therefore, the method of writing still further, the priests turned many of the outlines into arbitrary marks, which in course of time so deviated from their originals, as to render it almost impossible to trace them to their archetype, but which were nevertheless much less complicated and more expeditious. Thus, after incredible labour, through the lapse of many ages, were produced the three different modes of writing among the Egyptians, designated by the appellation of *hieroglyphic*, *demotic*, and *hieratic*. Into the nature of these our limits do not permit us to enter; but they constitute a subject well worthy of attention.

The next step of improvement was to form a connexion between the object represented, and the *sound* of the word used to express it. Nor was this so difficult as would at first sight be supposed: for when a man represented any image or picture, that of a "door" for instance, he would naturally give to the combination of lines with which that figure was formed, the name of a "door;" and wherever he met with this representation, or even though he should change it for some arbitrary and more simple mark, having the same signification, the same name would still remain attached to it, and by this means the word *door* would for ever afterwards remain associated with a certain outline or figure. The Hebrew alphabet affords a most satisfactory illustration of this. Every letter is, in fact, a word, and expresses some simple object. *Deleth*, for example, their fourth letter, corresponding with our D, signifies a "door;" *Beth*, their second letter, answering to our B, "a house," and in this manner each of the remaining letters of the alphabet have a meaning attached to them. Having attained this state of advancement, the progress of the art was more rapid. Every nation, in its turn, contributed some letters to the common stock; in a happy moment it was discovered, that each monosyllable terminated by a sound which, with very little variation, was repeated in all. Nor was it difficult to ascertain the number of these which were invariably fixed to the four or five inflexions of voice. Thus were vowels added to consonants, and mankind gradually arrived at the greatest of all inventions,—the invention of the alphabet. But who was the man, or what his nation, to whom the honour of this invention is due, is still disputed by the learned, though the majority agree in considering the presumption to be strongest in favour of Thoth, a son of Mizraim, the father of the Egyptians.

This noble invention diminished to a prodigious extent the difficulty of writing, it shortened the labour of memory, and was capable of expressing all subjects, and all ideas. The Phœnicians obtained a knowledge of the system, imparted it to the Greeks, whence it was gradually spread over the continent to our islands, and was at length diffused over the whole world. The first substance used for writing upon is considered to have been dried leaves; but there is much evidence to show, that plates of brass, lead, wood, stone, ivory, and wax, were also used. The ancients generally used tables covered with a coat of wax, on which they wrote with a *style*, a piece of iron pointed at the end, with which they made the letters, and blunt or flat at the other end, which they used for rubbing out what they had written, either when they wished to make any alteration or to use the table for other writings. By a good or bad *style*, therefore, they meant

at first simply to denote the quality of the instrument with which they wrote. The term was afterwards applied metaphorically to the language : in which sense it is now used.

Among the different substances that were employed for writing upon, before the art of making paper from linen-rags was discovered, we find the earliest to have been these tables of wood, made smooth, and covered with wax. But as what was written on wax might easily be defaced, leaves of the *papyrus*, a kind of flag, which grew in great abundance in the marshes of Egypt, were dried, and by a particular process prepared for writing. Sheets were also separated for the same purpose from the stem of the plant. On these, the letters were engraved with an instrument similar to that used for writing on wax. The substance so prepared was called *charta*, from a city of Tyre of that name, near which the plant was also found. The words *folia*, *leaves*, and *charta paper*, thus derived, are well known among ourselves.

As in writing a treatise, a great number of these leaves or sheets was required, they were joined together by making a hole and passing a string through each of them. With the same string passed several times round them, they were confined, to prevent their separating, and being injured or lost when no one was reading them ; whence it is supposed that a roll or bundle of them obtained the name of a volumen, or *volume*. Those who have seen specimens of the Burmese writing on leaves thus collected, may form an accurate notion of an ancient papyrus volume.

Another article used for writing, was the inner bark of certain trees. This was prepared by beating it, and then cementing it together by a solution of gum. As the inner bark of trees is called *liber*, the volumes of books were thence called *libri*, a name they still retain. Vellum, the last substance to be mentioned, is said to owe its origin to the following circumstance. Eumanes, King of Pergamus, being desirous of forming a library that should equal, or exceed in number the far-famed library of Alexandria, Ptolemy, King of Egypt, with a view of frustrating his design, prohibited the exportation of the papyrus. This excited the industry of some artists in the court of Eumanes : they contrived a method of preparing the skins of sheep, and it was called vellum, from vellus, a fleece or skin ; and *parchment*, from Pergamus, the place where the art of preparing it was discovered : or, if not discovered, it was there improved, and first brought into general use.

The Greeks and Romans as well as most of the eastern nations adopted the form of the continuous roll. There were two rollers, one at each end of the roll, round one of which the whole manuscript was folded : the reader unrolled one end, and as he proceeded, he rolled it upon the empty roller until the whole was transferred from one roller to the other. Notwithstanding the great inconvenience which this contrivance inflicts upon readers, especially when they have occasion to refresh their minds by occasional references to passages lying under many coils of the roll, our Court of Chancery retains the "good old practice," for the purpose, it would almost appear, of deterring people from reading the specifications of patents and other public records. Persons who go to read these documents at the *Inrolment Office*, or *The Rolls Chapel Office*, should prepare themselves to have the sleeves and breasts of their coats grouted in by the lime dust by which the rolls of parchment are whitened !

Although much information upon the manners of the Romans has been obtained by the discovery of two Roman cities, which had been hidden by the cinders thrown from Mount Vesuvius, by the eruption about the year A. D. 79 ; but little more is known upon the subject of their books and manner of writing, than was known before the excavations. Rolls of brittle material, about eight inches long and about two inches in thickness, were frequently discovered by the workmen during the operations at Pompeii ; but it was not first known that these were books : upon examination, however, they proved to be papyrus glued together. At one end of most of them was a label, upon which was written the title of the book, and the author's name. Of these rolls, Camillo Paderni carried away three hundred and thirty-seven, which he collected from the rubbish during twelve days which he passed among the ruins of Pompeii.



The papyrus has become so brittle, in consequence of the heat of the ashes, that no one has yet succeeded, to any extent, in unrolling them. Piasa, a monk, discovered a way of unrolling them, by putting thin slices of onion between the folds of the manuscript as he carefully separated them with a knife. This is the best contrivance which has yet been adopted, but it cannot be said to have proved successful. After all the time and money which have been bestowed upon this object, it is to be regretted that few works have been recovered. Some of these rolls are forty feet in length; many of them have been taken to the University of Cambridge, where they have remained many years, without any attempt having been made to unroll them.

The labour bestowed upon ancient manuscript books was immense. As they were intended to answer all the purposes of a modern printed book, their durability was of the greatest importance. The ancient copyists therefore paid great attention to the manufacture of their inks, as well as the parchment; in this art they were so successful, that most of the very ancient manuscripts which are now extant, are as legible, and the ink is as black and bright, as if they had been but just written. It is supposed that the ink owes this beautiful colour to the lamp-black. Some ink was found in a glass bottle at Herculaneum, which was very thick and oily. It was owing, perhaps, to its glutinous nature, that the persons employed to take down the speeches delivered by the orators in the Forum, preferred writing on waxen tablets, which required a very slight touch to mark them. It would have been an operation almost laborious to write with such ink as this found at Herculaneum, and the writer would have proceeded very slowly, and would not have been able to follow the speaker. There is one great objection to this ink; it does not enter sufficiently into the parchment, and is, therefore, easily obliterated. The Romans made ink of various colours; the emperors in the latter times, when wealth and luxury had destroyed the empire, endeavoured to make an appearance of grandeur, by writing with purple ink. Materials more valuable were sometimes used, when the writings were of value; the works of Homer were written in letters of gold, upon a roll 120 feet long, formed of the intestines of serpents. The Hebrews also are remarkable for the beauty of their manuscripts; the letters are as evenly formed as it would be possible to form them in a type; it is almost impossible to believe that they can have been written by a pen. All the eastern nations make their pens of reeds, which were well suited to the broad character of their writing; the reeds are brought from the East to Europe, and are used by the scholars in eastern literature; they are still used by many people in the East at this day. Reeds were used by other nations also. Pens made of them were discovered during the excavations at Pompeii; they are cut like a quill pen, except that the nib is much broader.

The quill pen appears to have been introduced about the year 600; the word *penna*, meaning a quill, is not found, it is said, in any work of an earlier period; previous to that date, the word *calamus* was used, which signifies a reed. Paper was introduced into Europe in the ninth or tenth century. It had previously been manufactured in China from a very remote period. About the year 716 a manufactory of it was established at Mecca, from whence it was brought by the Greeks to Constantinople.

We might have extended this article by some account of modern writing, but our space will not admit of it; and it is scarcely needful, as most of our readers are well informed upon the matter. We shall therefore conclude by a few remarks upon the peculiar direction of the writings of different nations. The Jews write from the right hand to the left; the Chinese from the top to the bottom; most other nations write as we do, from the left to the right.

## X.

**XEBEC.** A three-masted vessel of a peculiar construction; chiefly employed in the Mediterranean. They are built extremely low, with a very convex deck, and carry a great press of sail. As the sea commonly breaks over the deck

they are provided with grated platforms at the sides, for walking upon. We have occasionally seen them in the Thames, employed as merchantmen, but their chief employment is in warfare.

## Y.

**YACHT.** A sailing-vessel, fitted up with great elegance, and replete with conveniences. It is difficult to define any peculiarity belonging to them; as the term yacht is applied to so great a variety of forms; some represent complete three-masted *ships*, but of a diminutive size; while others are mere pleasure *boats*.

**YARD.** An English lineal measure, containing three feet, or thirty-six inches; also 1760 yards make a mile. The square yard contains  $3 \times 3 = 9$  square feet; 4840 square yards are an acre, and 3,097,600 a square mile. The cubic or solid yard contains  $(3 \times 3 \times 3) = 27$  cubic feet. The yard by which cloth is measured, is the lineal yard above-mentioned, but for convenience, divided into four quarters, or sixteen nails. This measure was instituted by Henry I. being the length of his own arm.

**YARD.** A long piece of timber or pole tapered towards each end, and suspended upon the masts of a vessel, to extend the sails to the wind.

**YARN.** Flax, wool, or other fibrous matter, spun into a loose thread; of which cloth or cordage is made. The process in preparing yarn, has been generally treated under the various substances of which it is formed. In this place we shall therefore confine our attention to yarn of a peculiar character, for which a patent was granted in 1832, to Mr. Greaves, of Chorley, in Lancashire. This invention consists in dyeing cotton in the wool, of various colours, and of every gradation of tint, and to mix the same up in various ways, with bleached white cotton, so as, by their union, to produce a self-varied colour of yarn, thread, or stuff, without such fabrics undergoing afterwards, as usual, the process of dyeing.

The patentee states his plan to be, to dye separate portions of cotton-wool of the seven primitive colours; and other portions of cotton-wool of various shades or tints of the foregoing; and with these, together with white cotton, according to the taste of the operator, to prepare yarn. Suppose, for instance, that the manufacturer required a peculiar green, he would take the primitive colours, yellow and blue, and mix them together in such proportions as would produce the exact tint desired, adding yellow to lighten, and blue to deepen the colour; if an orange, yellow and red; if purple, blue and red or pink; and by varying the nature and proportions of the combination of the primitive colours of the cotton-wool, and their several shades, every possible variety of tint, and every gradation of shade, may be obtained with the utmost facility.

When the due proportions of coloured cotton are put together, it is to undergo the same processes as if it were in a white state,—such as roving, spinning, twisting, winding, and doubling, to make it into yarn or thread, in which state it may be either used for sewing, embroidery, &c., or be woven into fabrics, as in other yarns, and will not require any subsequent operation, such as dyeing, beside avoiding the bleaching process, which is always liable to deteriorate the colour as well as the strength of the fabric.

A method of printing yarn was also patented by Mr. Schwabe, of Manchester, in 1831, which is described, with figures, in Hebert's "Journal of Patent Inventions," vol. vi. p. 171, which we have not space to insert.

**YEAST.** The scum thrown up in the fermentation of beer. See BARM, FERMENTATION, BREAD, and BEER.

**YTTRIA.** A peculiar substance discovered in 1794, by Gadolin: whether it be an earth or metal, the learned are not agreed. That great authority, Sir H. Davy, says that it consists of inflammable matter, metallic in nature, combined with oxygen. Its specific gravity is 4.842.

## Z.

**ZAFFRE.** The residuum of cobalt, after the sulphur, arsenic, and other volatile matters of this mineral, have been expelled by calcination. The ores of cobalt are roasted in verberatory furnaces, provided with chambers to receive the arsenic: the product of zaffre is usually about 68 per cent. of that of the ore. The ores that contain much nickel are not fit for the preparation of zaffre, as the oxide of nickel would injure the beauty of the blue colour, or smalts, for the making of which zaffre is manufactured. Inferior kinds of zaffre are made by mixing this oxide, previously stamped and sifted to a fine powder, along with calcined flints or quartz, also ground in various proportions according to the use for which it is intended, moistening the whole with water, and packing it tight in casks, where it hardens to a stone. A very fine zaffre, or China blue, is obtained from the arsenical and grey cobalt ore, found in Cornwall, by boiling the powdered ore in nitric acid, which converts the arsenic into arsenical acid, and unites it with the different metals contained in the ore. The solution being diluted with a large quantity of water, purified pearl-ash water is then added in small portions to the diluted solution; and on the addition of each portion the liquid is well stirred, left to settle, and the clear part poured off. This is repeated until the solution becomes of a rose colour, which shows that it contains only the arseniate of cobalt. The pearl-ash water is then added in larger quantity than is necessary to throw down all it contains, and the solution is boiled for a few minutes. Being then left to settle, the liquid is filtered, the oxide of cobalt left on the filter, washed with boiling water, and dried. This oxide is then melted with feldspar and a little potash, and thus yields a beautiful zaffre for painting porcelain. Another method is to grind the ore, mix it with two or three times its weight of China ware, grossly powdered, and heat it very strongly. The whole is then put into three or four parts of nitric acid, diluted with an equal weight of water. The clear solution is poured off, evaporated gently to a syrupy consistence, diluted afresh with water, left to settle, poured off clear from the arsenic that is separated, and then the pearl-ash water is added by small portions, and the operation finished as in the former process. Zaffre is used for making smalts, and for painting on the best kinds of pottery. The common zaffre is cheap, but the best sells for two guineas the pound in the potteries. Zaffre is likewise used in the manufacture of cobalt.

**ZEALAND (New) FLAX.** The *phormium tenax* of naturalists. Its commercial name has been acquired from the circumstance of the natives of New Zealand employing it in the manufacture of their apparel, cordage, and all those purposes for which hemp and flax are used in other countries. The strength of its fibres, however, greatly exceeds those of the last-mentioned vegetable substances; and indeed, nearly approaches the tenacity of silk. Of this plant there are two sorts,—one becoming a red flower, the other a yellow. The leaves of both are similar to those of the common flax plant, but the flowers are smaller, and the clusters more numerous. The Zealanders obtain the flax from them by very simple and expeditious means. The fibres are beautifully fine, and white, shining like silk; the cordage made from it was found by our navigators to be very much stronger than any thing we could produce with hemp. With the view of introducing the growth of so valuable a plant in this country, Captain Ferneaux brought over some of the seeds, which were sown in Kew Gardens, by order of his late Majesty, but unfortunately failed. Subsequent to this period, the culture has been very successfully pursued by our settlers in New South Wales. We are indebted to Mr. Wm. Salisbury, of Brompton, for the discovery of this identical plant, growing indigenously in the south of Ireland, where it flourishes luxuriously. This discovery will probably prove, ultimately, of the utmost importance to Ireland, where the poor may be profitably employed, both in the culture and subsequent manufacture. Mr. Salisbury observes, that plants of three years old, will, on an average, yield thirty-six leaves, besides a very considerable increase of off-sets; which leaves being cut

down, at the time of clearing the quarters in the autumn, are found to spring up again in the following summer.

Respecting the produce, the same gentleman states, "Six leaves have produced me one ounce of fibres, when scutched perfectly clean and dry; at which, an acre of land planted with this crop, at three feet distance from plant to plant, will yield rather more than sixteen hundred weight per acre, which is a very great produce compared with that of hemp or flax. New Zealand flax may be scutched with little labour or trouble, and may be performed by persons in common. The leaves should be cut when full grown, and macerated for a few days in stagnant water, and then passed under a roller machine properly weighted; by this process the fibres become separated, and if washed in a running stream, will instantly become white. When the fibres are thus scutched clean and dry, any kind of friction will cause them to divide into any degree of fineness in the *harle*, so far even, as to cottonize; whereby it is fitted to all the purposes to which hemp and flax are adapted."

This plant is, at present, under cultivation in several parts of England and Wales. It will grow in either a moist or a dry soil; on a hill, or in a valley, but most luxuriously where there is an abundance of moisture.

New Zealand flax has at length become one of our established manufactures, and is now wrought into various articles of commerce; every improvement, therefore, in its preparation, that will economize the process, and extend its useful applications, is well deserving of record. Accordingly, we subjoin an account of the patent granted to Mr. J. Holt, jun. of Whitby, in Yorkshire, designed with those views.

In the manufacture of tarred cordage, the chief obstacle to the employment of that strong fibrous vegetable material, known by the term of New Zealand flax, (but which also comes from Manilla, and other parts of the East,) has been the apparent impossibility of making the fibres absorb or unite with the preservative fluid. In consequence, the chief use of the New Zealand flax has been confined to the preparation of white cordage. The patentee informs us in his specification, that he has discovered that the ultimate fibres of the flax are combined and enclosed by a coating of adhesive matter, which requires the application of some chemical solvent to set the fibres at liberty, and adapt them to the reception of tar; and the solvent which effects this object completely and economically, he finds to be a weak solution of potash of soda. His process is as follows:—

The flax having been heckled and spun into yarn in the usual manner, is in a suitable state for the chemical procedure; which consists in immersing it in a solution of potash or soda, in the proportion of half an ounce of alkali to a gallon of water, which may be either hot or cold. When the flax has been thus submitted to the action of the alkali for forty-eight hours, it is to be taken out, wrung, and hung up to dry, either in the air or in a stove. When dried, the flax will be found adapted to imbibe the tar as readily, and hold it as firmly, as the hemp in ordinary use; in performing which process, and all that may be subsequent, the rope manufacturer need make no variation from his accustomed proceedings. There is likewise included in Mr. Holt's patent, some improved mechanical apparatus for depriving the New Zealand flax of the bark and skin with which it is found combined in the commercial state. A kind of grating, made either of iron or wood, is provided, consisting of a range of parallel bars, the whole forming a right-angled parallelogram, having its two opposite longest sides inclosed by vertical boards. The bars in their transverse section are tapered, with their narrow ends or sides placed upwards in this frame; but another similar frame of bars, which is made to fit and pass over the former, has its bars with the narrow ends or sides downwards; which arrangement gives the respective frames of bars a tendency to interlock in the same manner as toothed wheels; and, therefore, when the raw flax is spread upon the lower frame of parallel bars, and the upper frame duly loaded, is laid over the flax, and passed backwards and forwards, a powerful and uniform rubbing action is produced upon the flax, which opens the fibres, while it separates the bark and other extraneous matter, which falls through the bar of the lower fixed

frame, and is collected underneath. For the convenience of supplying the flax to the lower frame, the latter is at the middle divided into two portions or flaps, which open like the lids of boxes, but meet together when down with serrated teeth, for the purpose (we suppose) of holding the flax in its place whilst being rubbed.

**ZEINE.** This name has been given to a substance obtained by Mr. Gerham from maize or Indian corn, by infusing it in water, then filtering and treating the undissolved matter with alcohol, and evaporating the solution effected by the latter liquid. He thus obtained a yellow substance having the appearance of wax, and of a soft, tough, elastic nature, and heavier than water; resembling gluten, yet affording no ammonia by decomposition.

**ZERO.** A scientific term applied to the commencement of a scale, and marked with an O. It is the point or beginning from which the scale or distances are graduated. Thus, the zero of Fahrenheit is 32° below the freezing point of water. In the centigrade scale, the zero is made that of freezing water, or 32, of our scale.

**ZIMOME.** The gluten of wheat treated by alcohol is reduced to the third part of its bulk. This diminution is owing, not merely to the loss of gliadine, but likewise to that of water. The residue is zimome, which may be obtained pure by boiling it repeatedly in alcohol, or by digesting it in repeated portions of that liquid cold, till it no longer gives out any gliadine. Zimome is found in several kinds of vegetables. It differs from gluten in its mode of fermentation, and varies in that respect according to the nature of the substances it comes in contact with.—*Ure.*

**ZINC.** A metal of a bluish-white colour; of considerable hardness, and so malleable, when pure, as not to be broken with the hammer, though it cannot be thus much extended. It is, however, easily rolled into sheets, by the flattening-mill; and in this state, it has recently been brought into very extensive use, in the manufacture of pipes, gutters, and a great variety of vessels and utensils. Its specific gravity is 7.0. In a temperature of from 210° to 300°, it possesses so much ductility, that it can be drawn into wire as well as laminated, for which process, a patent was granted to Messrs. Hobson and Sylvester, of Sheffield.

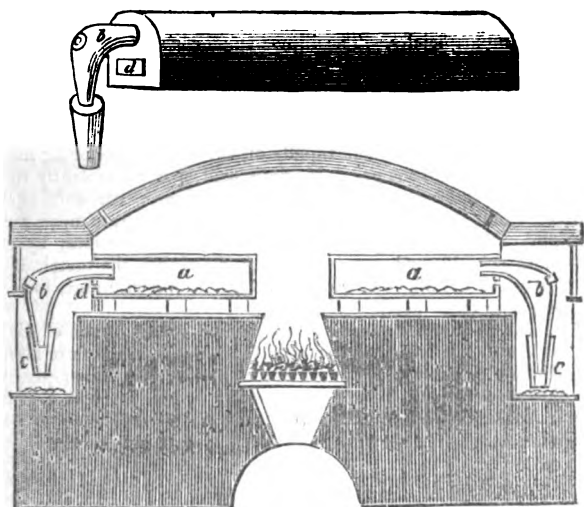
Zinc melts at about 700° Fahr.; by continuing to raise the heat, it soon after becomes red hot, and burns with a dazzling white flame, and oxides with such rapidity, as to fly up in a flocculent form, which is called the flowers of zinc. When these are urged by a strong fire, they are converted into a clear yellow glass.

In the ordinary method of preparing the sulphate of zinc, or spelter, the ore is exposed to the heat of a furnace, in a melting-pot, from the bottom of which a pipe descends into a vessel of water, for the purpose of receiving the metals as they are melted, and for condensing such portion as pass off in the form of vapour. An improvement upon this mode was the subject of a patent, about fifteen years ago; in which it was so arranged, that as the zinc volatilized, the vapour should be received and condensed in a separate vessel, leaving the melted metal, such as lead, and other impurities, in the former. An improvement upon this mode of operating, was lately patented by Messrs. Benecke and Shears; their process consists, first, in a peculiar treatment of the ore, previous to its introduction into the furnace; and secondly, in a peculiar arrangement of the retorts, and other appendages, by which a more convenient mode of charging the retorts is obtained, and a purer metal is the result.

The ores are first to be roasted in the ordinary way, by stratifying them with fuel, and setting fire to the pile. The ore is next spread out in the air, and lixiviated, to separate the sulphate of zinc; it is next to be dried, pulverized, and roasted a second time, until the sulphur is extricated, when it should be powdered again, and mixed with an equal quantity of carbonaceous matters, such as powdered coal, charcoal, cinders, &c.; in this state, it is to be saturated with an alkaline ley, or a solution of common salt; the solutions varying according to the nature of the ore. Calamine, or other oxides of zinc, will require only to be pulverized and calcined.

With the ores prepared as before mentioned, the retorts are to be charged

one of those is shown in perspective at *a* in the annexed figure; they are made of fire-clay, or of such earth as will best stand the heat of the furnace. To the front end of these retorts are two apertures: the upper circular, for the reception of



the neck of an earthen head-piece *b*; the lower, *d*, is square, for clearing out the residuum after working, which is closed during the distillation, by a stopper, and luted. The head-piece has likewise another tube fitted to it, and luted, merely for the purpose of lengthening it sufficiently to allow the vapour to cool as it descends, and to condense upon an iron plate beneath, as shown in the lowest figure in the diagram, which represents a cross or vertical section of a reverberatory furnace, in which a double row of such retorts may be supposed to be arranged, with a long aperture between them, where the fire is situated, which rests upon a grating over an arched passage that communicates with the open air outside the building; this arched passage has a door, by the opening and shutting of which the heat of the furnace is regulated as may be required; and through one of the ends of this long passage an aperture is made for supplying the furnace with fuel. The earthen head-pieces *b*, it will be observed, have an aperture supplied with a stopper; through these openings the ore and carbon, prepared as before mentioned, are introduced in sufficient quantity, by means of a ladle, into the body of the retort, when the apertures are closed and luted. The operation of distillation then commences; the zinc, which rises in vapour, passes into the head-piece *b*, down the pipe *c*, and falls upon the iron plates beneath, in a condensed state.

By the arrangement described, the heads and necks of each retort are placed in a square recess or neck by itself, by walls built out between them, so that each may be perfectly closed in by a door from wall to wall. The doors are made of latticed wire work, for the purpose of holding clay when plastered over them, for the purpose of effectually confining the heat within the furnace; each of these doors has a central eye-hole, provided also with a stopper, for watching the progress of the operation, and for enabling the workmen to determine the degree of heat to be applied, and other circumstances. By another arrangement the before-mentioned patentees propose to erect furnaces with several tiers of cylindrical retorts, placed one above another, with their necks or heads projecting beyond the front wall. The fire-place is covered by a low arch, to prevent the fire acting too violently upon the lowermost vessels; but through the arch apertures are made for the circulation of the heated air among the vessels above.

The carbonate of zinc, which is employed as a white pigment, is manufactured by pouring into a solution of zinc, in sulphuric acid, a solution of carbonate of ammonia, and afterwards washing and drying the precipitate. The next important use of zinc is in the fabrication of those useful and beautiful alloys with copper, called brass, prince's metal, &c. See ALLOY, COPPER, BRASS, &c.

*Blende* is the native sulphuret of zinc: the two substances are, however, difficult to combine artificially. The diluted sulphuric acid dissolves zinc, giving out much heat to the solvent, while hydrogen escapes. An undissolved residue is left, which Proast says, is a mixture of arsenic, lead, and copper. The white vitriol, or white copperas, as it is usually termed, is crystallized rapidly, resembling loaf sugar. Sulphurous acid also dissolves zinc, sulphuretted hydrogen being evolved. Diluted nitric acid rapidly dissolves zinc, producing much heat, with the extrication of nitrous gas. Muriatic acid operates violently upon zinc, disengaging much hydrogen. The phosphoric, fluoric, carbonic, acetic, succinic, benzoic, oxalic, tartaric, citric, and other acids, operate upon zinc, with various energy. The zinc is precipitated from its acid solutions, by means of the alkalis and soluble earths; the former re-dissolving the metal, if they be in excess. Most of the alloys or metallic combinations with zinc, have already been noticed under other heads.

ZIRCONIA. A metallic substance, discovered in the jarzon of Ceylon, by Klaproth, in 1789. It unites with the acids, is insoluble in the pure alkalis, but soluble in alkaline carbonates. It does not melt before the blowpipe, but emits a yellow phosphoric light. Strongly heated for several hours in a crucible, it undergoes a species of fusion; having then some resemblance to porcelain, strikes fire with steel, scratches glass, and has a specific gravity of 4.3.

END OF VOL. II. ENGINEER'S AND MECHANIC'S ENCYCLOPÆDIA.

H 1/2

R. CLAY, PRINTER, BREAD-STREET-HILL.

1  
2  
3  
4  
5  
6  
7  
8  
9  
10  
11  
12  
13  
14  
15  
16  
17  
18  
19  
20  
21  
22  
23  
24  
25  
26  
27  
28  
29  
30  
31  
32  
33  
34  
35  
36  
37  
38  
39  
40  
41  
42  
43  
44  
45  
46  
47  
48  
49  
50  
51  
52  
53  
54  
55  
56  
57  
58  
59  
60  
61  
62  
63  
64  
65  
66  
67  
68  
69  
70  
71  
72  
73  
74  
75  
76  
77  
78  
79  
80  
81  
82  
83  
84  
85  
86  
87  
88  
89  
90  
91  
92  
93  
94  
95  
96  
97  
98  
99  
100









MAY 19 1930



