

LUDLOW

Supersurfacers

INSTRUCTIONS

&

PARTS LIST

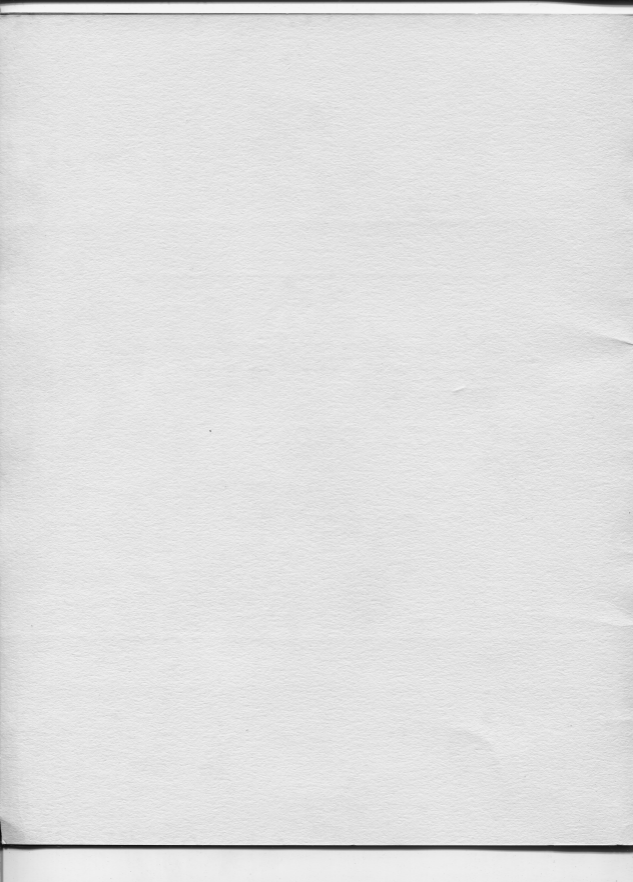

**LUDLOW
SUPERSURFACER
INSTRUCTIONS
&
PARTS LIST**



Branch Offices:

NEW YORK (17) 589 Fifth Avenue

BOSTON (10) 200 Summer Street

ATLANTA (3) 120 Marietta Street

SAN FRANCISCO (2) 760 Market Street

•
Cable Address

LUDTYPE, CHICAGO

Ludlow Typograph Company

2032 Clybourn Avenue, Chicago 14, Illinois

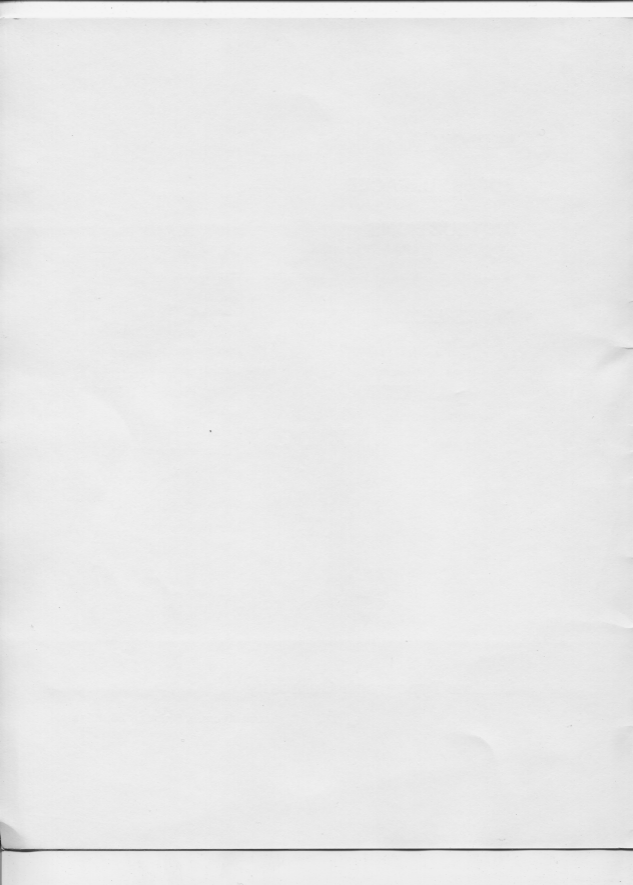

How to Order Parts

1. Look up part wanted on Plates 1 to 6 of the Parts Manual in order to obtain part number. Description of part is given on pages 9 to 14 inclusive.
2. When ordering parts, give part number and name, and serial number of machine.
3. When ordering electrical parts give the voltage, and state whether current is alternating or direct. Also give cycles of alternating current.
4. Please specify whether shipments are to be forwarded by first-class mail, air mail, parcel post, express or freight.

Place your machine Serial Number
here for convenience in ordering parts:

Serial No. _____

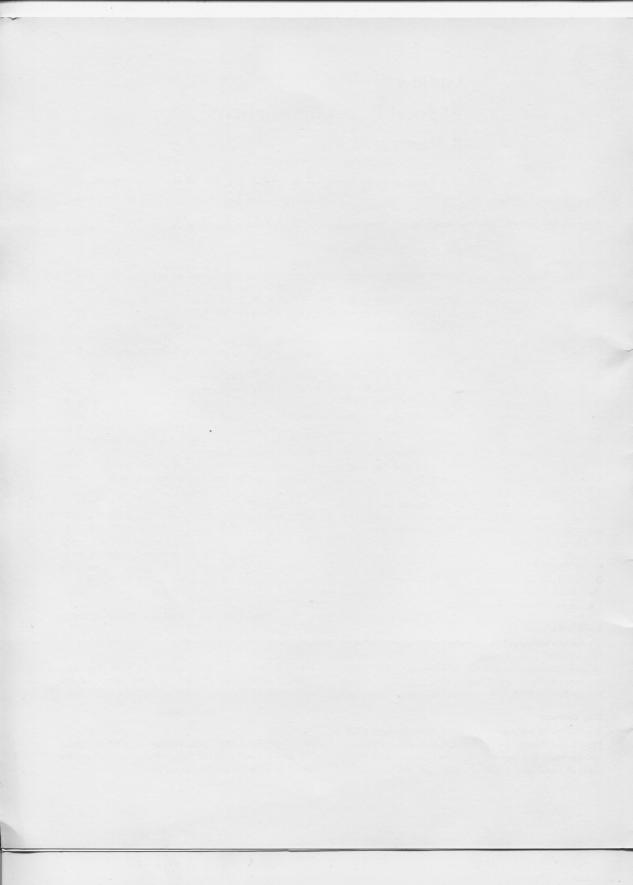

Ludlow

Supersurfacers Instructions & Parts List

The Ludlow Supersurfacers is a single-purpose machine designed to take a very light surface cut from the face of the larger and bolder type slugs of any cross-section up to and including 96-point size and as long as a 42-pica length of measure

Dimensions

The base of the pedestal of the SUPERSURFACER measures 16" x 16". The overall dimensions are 24" x 19". The height of a slug carriage from the floor is 33"; the overall height, including the slug tray rack, is 49". Crated for domestic shipment, the gross weight is 350 lbs. (for export—404 lbs.); the net weight is 225 lbs. The Crate dimensions are 25" x 25" x 49".

Power

The one-quarter horsepower motor is mounted below the table and, through the aid of an endless "V" Belt 6050, Plate 1, drives the cutter spindle at a speed of 4200 rpm.

Cutter

The Cutter is equipped with inserted blades ground on both ends, thereby permitting reversal of the Cutter Assembly, A6151, Plate 4, when one side becomes dull.

Two Cutter Assemblies are supplied with each SUPERSURFACER, one of which is mounted on the machine at time of shipment, and one specially-boxed extra cutter. The special box is to be used when a dull cutter is returned to the Ludlow Company for re-sharpening.

Cutter Adjustment

On the left side of the machine is the Micrometer Assembly, Plate 2, for regulating the depth of the surface cut to a fraction of a thousandth-of-an-inch.

Spindle Bearings

The Spindle 6008-A, Plate 4, revolves on greased-sealed type Bearings 6007A and 6006A, Plate 4, and no further lubrication is necessary. The spindle is also capable of withstanding heavy end and radial loads; is springloaded endwise, Spindle Springs 6199, Plate 4; thus all end play is eliminated.

Slug Carriage

The slug to be surfaced is placed on the Slug Rest, 6115, Plate 1, and clamped on its side. The Slug Rest upon which the slug seats is grooved to serve as a scraper so that the chips of metal adhering to the Slug Rest will be brushed

aside when the slug is moved back and forth prior to clamping the slug in position.

The slug is held in position under spring pressure clamping action by the Clamp Equalizing Bar, 6125, Plate 1,2, the Carriage Clamp, 6119-A, Plate 1,2, on which the slug holder is mounted travels on the rigid Carriage Slide Rods, 6114A, Plate 1,3, and is provided with adjustments for wear by means of Slug Rest Adjusting Screws, 604A.

After the carriage has been moved the entire length of its travel and the return stroke started, it is automatically raised so the cutter will not contact the face of the slug on the return stroke of the carriage. At the end of the return stroke the carriage automatically drops to normal position on the left slide rod way. Carriage Rod Wipers, 6111-B, Plate 1, on the left carriage slide rod travel with the carriage and keep the left carriage slide rod clean, thus insuring perfect contact of the slug carriage with left carriage slide rod.

Slug Face Lubrication

Before the face of the slug contacts the cutter it is automatically lubricated by an oiled Slug Oiler Felt Washer, 6038-A, Plate 4. The oil deposited on the face of the slug prior to surfacing prevents type metal from adhering to the cutting edges of the cutter blades during the surfacing operation, thereby preventing a scored face on the slug.

Chip Pan

The slug shavings drop into a removable Chip Pan, A6062, Plate 3, located below the cutter.

Slug Tray Rack

The SUPERSURFACER is equipped with a Slug Tray Holder, 6056A, Plate 1, for holding either half or full-size slug trays.

Installation

Unpacking

The SUPERSURFACER is thoroughly tested before leaving the factory. Care should be taken that no adjustments are moved when the machine is unpacked.

To unpack:

1. Remove the crating lumber from the base upon which the Surfacer is cleated.
2. Remove the wooden box which contains the oil and special cutter box containing extra cutter—which is strapped to the base of the crate.
3. Remove the Slug Tray Holder, 6056A, Plate 1, which is strapped to the base.
4. Remove the machine from the skid.

Assembling

The SUPERSURFACER is shipped completely assembled with the exception of the Slug Tray Holder, 6056A, Plate 1, which is to be mounted on the top of the Slug Tray Holder Bracket, 6057, Plate 1, with the top Style 45, 5/16-18 x 1/2" long Button Head Socket Cap Screws, 6056 1/2, located in the tapped holes on top of Slug Tray Holder Bracket, 6057, Plate 1.

Locating

It is desirable to leave a space of about 18" at the back of the machine to allow for cleaning and oiling. At least 2 feet should be allowed at both sides of the machine to provide room for adjusting, changing cutters, etc. The operator will require at least a 2 1/2 foot space at the front of the machine.

Electrical Connections

Before making any electrical connections, the name plate specifications on the motor should be carefully checked with the existing current. If the motor is to operate from the lighting circuit the cord and plug may be used for the electrical connection. If the motor is to operate from the power circuit an electrician should make permanent connections. See Plate 5—Electrical equipment.

Check Motor Rotation

After the electrical connections are made the motor rotation should be checked, as it is very important that the rotation of the cutter be counter clockwise when facing the cutter. The cutter must cut downward as the work passes by it. The direction of rotation of the cutter is also indicated by an arrow on the belt guard.

Check Position of Cutter

In packing, shipping and unpacking, the spindle head may become unlocked by movement of Spindle Housing Lock Screw 6011A, Plate 1, and the Micrometer Adjusting Screw Assembly, A6010A, Plate 2, turned. Therefore, before attempting to surface slugs the position of the cutter should be checked (see adjustments on page 7 "Positioning of Cutter").

Operation

Caution

DO NOT SURFACE SLUGS THAT HAVE BEEN BURNISHED. THIS IS OF VITAL IMPORTANCE TO THE

LIFE OF THE CUTTER. A slug burnished with abrasive paper contains partially imbedded particles of emery which will almost instantly destroy the cutting edges of a surfacing machine cutter. A caution plate is affixed to the front of the SUPERSURFACER housing warning the operator of this danger. Also type metal which contains particles of copper or other hard metals will destroy the cutting edges of the cutter.

Slugs to be Surfaced

We do not recommend the surfacing of slugs below 24 point, especially those of light faces.

Method of Operation:

1. Turn on Motor Switch, A129, Plate 1,5.
2. With the Carriage Body, 6118-B, Plates 2-3, in the forward position (nearest the operator), depress the Carriage Clamp Handle, 6123, Plates 1-2, to open the Carriage Clamp, 6119A, Plates 1-2, and place the slug to be surfaced in the Slug Rest 6115, Plates 1-2, against the stop rail at the rear of the clamp jaw. The grooves in the face of the slug rest and the stop rail will clean the bottom and side of the slug when it is placed in the slug holder and rubbed back and forth prior to clamping. Slugs with a smooth and a ribbed side on the body should be placed with the smooth side down so as to have the clamp exert the most holding power.
3. Depress, then release the pressure on the Carriage Clamp Handle, 6123, Plates 1-2.
4. Pressing very lightly in a downward direction against the left Carriage Slide Rod, 6114A, Plates 1-3, push the Carriage Body, A6118B, with slug clamped in position across the cutter to the end of its travel, taking a full two seconds for the carriage to travel from front to the rear of machine.
5. Return Carriage Body, A6118B, to starting position.
6. Depress Carriage Clamp Handle, 6123, Plates 1-2, and remove the slug.

Care

Lubrication

The following parts should be lubricated with the light grade machine oil (Symbol A6159) furnished with the SUPERSURFACER.

1. Motor Bearings—Follow instructions on motor instruction plate.
 2. Carriage Slide Rods, 6114A, Plates 1-3, — daily.
- The Slug Oiler Felt Washer, 6038-A, Plate 4, should be kept lightly oiled by adding oil in the Slug Oiler, 6034, Plate 4, at the top of the roller. Approximately one-half teaspoon of kerosene or very light oil should be added twice a day during normal operation of the SUPERSURFACER.
- The Spindle, 6008A, Plate 4, revolves on grease sealed Bearings, 6006A and 6007A, Plate 4, which do not require further lubrication.

Cleaning

A brush, 6066, Plate 1, is attached to the SUPERSURFACER for removing the chips of metal from the seat of the slug holder. Do not use this brush on the Carriage Slide Rods, 6114-A, Plates 1-3, as the brush should be kept dry.

The Cutters

When not in use, the Cutter Assembly, A6151, Plate 4, should be kept well oiled to prevent rusting.

Particular care must be taken not to damage or move the Cutter Blades, 6152, Plate 4, in the Cutter Assembly. The dislocation of one blade will destroy the quality of finish on the slug face.

Adjustments

The Cutter

As the Cutter Assembly, A6151, can only be sharpened by grinding with a special fixture, do not attempt to sharpen it with an oil stone or an emery wheel. A dull cutter should be returned for resharpener to the Ludlow Company in the special box supplied for that purpose.

To Change the Cutter:

1. Loosen the Micrometer Thimble Socket Lock Screw, 6003, Plate 2, in the Micrometer Thimble Assembly, A6002-B, Plate 2, with the special wrench.
2. Remove the Micrometer Thimble Stop Screw, 1276 $\frac{1}{2}$, Plate 2, from the Micrometer Thimble Assembly, A6002-B, Plate 2.
3. Loosen the Spindle Housing Lock Screw, 6011A, Plate 1, on front of the spindle housing.
4. Loosen the two Spindle Housing Screws, 6075, Plate 1, holding Cutter Guard, 6021, Plate 1, and remove guard in vertical direction.
5. Screw spindle to the left, away from carriage. Remove the Cutter Assembly, A6151, by removing the three, Style 45, $\frac{1}{4}$ "-20 x $\frac{3}{8}$ " long Hexagon Socket Cap Screws, 6154, using special wrench provided for this purpose.
6. See that the cutter seat and the end of the spindle are clean when reversing or changing the cutter. This is of greatest importance as they must be clean and absolutely free from particles of lead, dust or any foreign matter. If they are not, the result will be a cutter which will give the same results as one having high blades forced to perform all the cutting instead of distributing the cutting over all the blades. In other words, the cutter will not run true.
7. Place cutter in position and revolve against spindle end so the grooves in the end of the spindle will help clean the cutter seat.
8. Replace the three Style 45, $\frac{1}{4}$ "-20 x $\frac{3}{8}$ " long Hexagon Socket Cap Screws and alternately tighten a fraction of a turn to insure even seating of the Cutter Assembly, A6151.

9. Replace Cutter Guard, 6021. Whenever the Cutter Assembly, A6151, is changed it is necessary to position the cutter assembly for surfacing the slugs to proper height and then readjust the Micrometer Thimble Assembly, A6002-B, Plate 1, so that the graduation on thimble will correspond to the height of the slug as surfaced.

Positioning of Cutter:

1. (a) Loosen Style 45 Micrometer Thimble Screw, 6003, Plate 2, in Micrometer Thimble Assembly, A6002-B, Plate 1, with special wrench.
(b) Loosen Spindle Housing Lock Screw, 6011A, Plate 1, on front of spindle housing.
(c) Remove projecting Micrometer Thimble Stop Screw, 1276 $\frac{1}{2}$, Plate 2, from Micrometer Thimble Assembly, A6002-B, Plate 2.
2. Move spindle to extreme left by turning Micrometer Handle, 6001, Plate 2, counterclockwise. Remove Chip Pan, A-6062, Plate 1.
3. Place a typeface slug in the holder and move carriage back until the slug is opposite but not touching the cutter.
4. Start motor.
5. Advance cutter assembly toward the slug until the revolving cutter just touches the face of the slug.
6. Lock spindle housing with Spindle Housing Lock Screw, 6011-A, Plate 1. Push the Carriage Body, 6118-B, Plates 2-3, with the slug clamped in place, across the cutter to the end of the travel and return it to starting position. Repeat operation to insure surfacing the entire face of slug.
7. Using a micrometer caliper, measure the slug height at the ends of the slug over the surfaced part of the face, and set the Micrometer Thimble Assembly, A6002-B, Plate 2, on machine to this measurement. Advance the Cutter Assembly, A6151, Plate 4, to trim the desired height (.916", .917"). Replace Micrometer Thimble Stop Screw, 1276 $\frac{1}{2}$, Plate 2, in the Micrometer Thimble Assembly, A6002-B. Set and lock the graduated thimble on the Micrometer Screw, 6010A, Plate 2, to register this measurement.
Readings on the Micrometer Thimble Assembly, A6002-B, Plate 2, must be taken only when the Micrometer Handle, 6001, Plate 2, is turned clockwise to eliminate all end play in the adjusting screw. Adjustment for this end play is explained on page 8.
8. Replace Chip Pan, 6062, Plate 1.
9. Adjust Slug Oiler Assembly as explained on page 8.

Slug Carriage

The carriage ways, 6118-B, Plate 2, pivot on the right-hand guide rod and are slotted. Compensation for wear or looseness is regulated by two, Style 45, $\frac{1}{4}$ "-28 x $1\frac{1}{2}$ " Hexagon Socket Head Cap Screws, 6117-A, Plate 2-3, at these slotted sections. These members of the Carriage 6118B, Plate 2,

should be adjusted so there is no looseness of these bearings on the right-hand carriage Slide Rod, 6114-A, or inaccuracy of type-height will develop. However, the Carriage Body, 6118-B, Plate 2, should operate smoothly and must not travel hesitantly when it moves past the cutter.

Parallel Cuts

The Slug Rest, 6115, Plate 1-2, against which the slug seats determines the parallelism of the surfaced face to the foot of the slug. Measuring the ends of the slug with a micrometer gauge will determine if the surfaced face is parallel to the bottom of the slug. Two Slug Rest Adjusting Screws, 604A, are provided just behind Slug Rest for repositioning if and when required.

Squareness

The squareness of the trimmed surface to the Slug Holder is controlled by the two tapered parallel blocks. Carriage Slide Plate, 6116-B, Plate 2, underneath the Carriage Clamp which slide on the left-hand Carriage Slide Rod, 6114-A. By closing these blocks together the thickness is increased and the carriage seat is raised; by spreading them out the thickness is reduced lowering the carriage seat. This adjustment is made as follows:

1. Remove the right-hand Carriage Slide Rod, 6114-A, which is held in place by two Style 45, $\frac{1}{2}$ "-13 x $2\frac{1}{2}$ " long Socket Head Cap Screws, 6135.
2. Remove entire Carriage Clamp Assembly, Plate 2. Then release the four Carriage Slide Plate Screws, 6133, Plate 2, holding the parallel blocks (Carriage Slide Plate, 6116-B, Plate 2) in position and change their relative positions as indicated by lines on the front of the blocks. Tighten the four Carriage Slide Plate Screws, 6133.
3. Replace Carriage Clamp on Carriage Slide Rod, 6114A and refasten on Slide Rod Blocks, 6124A and 6134A, Plate 1,3.
4. Set a matrix stick full of your largest size typeface with cap H or W characters at both ends and cast several slugs.

Surface entire face of slug. Using a micrometer caliper, measure T-head thickness at four corners as near edges as is possible. Measurements should not differ more than .001". If necessary, repeat steps 1, 2, 3.

Left Slide Rod-Wear Adjustment

The left hand Carriage Slide Rod, 6114-A, Plate 1, is retained by two Style 4, $\frac{1}{4}$ "-20 x $\frac{1}{4}$ " long Round Point Slotted Headless Set Screws, 6178, Plate 1. As this Slide Rod becomes worn, it should be turned to one of the eight locations marked on the Slide Rod Block-Front, 6124-A, Plate 1,3, around the Slide Rod Hole.

When all eight positions have been used, the rod should be turned end for end, and a corresponding number of new wearing surfaces will be available, making a total of sixteen wearing surfaces on this slide rod. This will give many years of service before it needs replacement.

Slug Face Lubricator

The adjustable Slug Oiler Arm, 6027, Plate 4, which supports the revolving Slug Oiler Felt Washer, 6038A, Plate 4, must be adjusted so the felt just touches the face of the slug before it reaches the cutter but must not touch the slug on the return stroke of the Carriage Clamp. The Style 44, $\frac{1}{4}$ "-20 x $\frac{3}{4}$ " long Hexagon Socket Oval Point Set Screw, 659 $\frac{1}{2}$ A, Plate 4 and Style 102, $\frac{1}{4}$ "-20 x $9/64$ " thick Standard Regular Jam Nut 230, Plate 4, provide for this adjustment.

Micrometer Screw

Adjustment to reduce the play in the Micrometer Screw, 6010A, Plate 2, is provided without disassembly in the following manner:

1. Loosen Style 44, $\frac{1}{4}$ "-28 x $\frac{1}{4}$ " long Hollow Hexagon Set Screw, 6003 $\frac{1}{2}$, Plate 2, on Micrometer Spacer, 6009-A, Plate 2, with socket head wrench.
2. Insert wrench in Adjusting Spacer Collar, 6009 $\frac{1}{2}$, Plate 2 and turn in clockwise direction, drawing collar up until micrometer screw is free from lost motion.
3. Tighten socket set screw in Micrometer Spacer, 6009A.

Ludlow Supersurfacers

Parts List

Part Number	Description	Plate Number
13	Style 56, 3/8" Rd. x 1 3/8" Hardened Dowel Pin	
34-C	Ludlow Typograph Co., Ltd., Nameplate	
34 1/2	Edwards Dunlop & Co., Ltd., Nameplate	
37 1/2	Nameplate Screw	2
38 1/2 A	Societe Michel (France) Name Plate	
39 1/2	Seligson & Clare, Ltd., Name Plate	
47 1/2	A. M. Satterthwaite & Co., Ltd., Name Plate	
76	Style 1, 1/4"-20 x 3/4" Long Filister Head Screw	1
95	Style 101, 5/16-18 x 1/4" Long Hexagon Nut	4
108	Motor Switch (Start) Tube	
121 1/2	Motor Switch Cover Screw	5
122 1/2	Motor Switch Cover Screw Retaining Washer	5
123 1/2	Gasket for Unilet	5
A124 1/2	Unilet Cover	5
A129	Motor Switch (Single Phase)	1-5
A129 1/2	Motor Switch (Three Phase)	5
A130 1/2	Motor Switch Cover	5
A130 1/2-1	Motor Switch Cover Plate Sub-Assembly	
S-135	Style 55, #0 x 1" Long Taper Pin	2
148	Style 3, 5/16"-18 x 1 1/4" Long Hexagon Head Cap Screw	
158	Style 202, 1/4" Shakeproof Washer	
168	Style 3, 5/16"-18 x 1/2" Long Hexagon Head Cap Screw	3
171	Style 1, 1/4"-20 x 5/8" Long Filister Head Screw	
M-210	Style 3, 5/16"-18 x 3/4" Long Hexagon Head Cap Screw	
230	Style 102, 1/4"-20 x 9/64" Thick Standard Regular Jam Nut (7/16" across flats)	4
298	Style 56, 5/16" Round x 1 1/8" Long Hardened Dowel Pins	
304-E	Style 7, 8-32 x 1/4" Long Rd. Head Brass Screw	5
305-E	Style 102, 8-32 x 3/32" Thick Brass Nut	5
324-E	1/2" Conduit Lock Nut	
372	Slug Oiler Plunger Spring	
445-A	Bumper Spring	2
451	Style 8, 1/4"-20 x 1/2" Long Flat Head Machine Screw	
452	Style 56, 3/16" Diameter x 9/16" Long Dowel Pin	2
562	Style 102, 5/16"-18 x 11/64" Thick Standard Jam Nut	2-3
584	Style 201, 11/16" O.D. x 21/64" x 1/16" Steel Washer	3
604-A	Slug Rest Adjusting Screw	
659 1/2 A	Style 44, 1/4"-20 x 3/4" Long Hexagon Socket Oval Point Set Screw	4
681 1/2	Style 44, 1/4"-20 x 3/8" Long Hexagon Socket Cap Point Set Screws	
734	Style 7, 1/4"-20 x 1/2" Long Round Head Screws	5
748 1/2 EA	#8 Solistrand Terminal for No. 14 and No. 16 Wire	5
750 1/2 EA	#10 Solistrand Terminal for No. 14 Wire	5
807	Style 1, 3/8"-16 x 1" Long Flat Filister Head Screw	
A840	Style 27, 3/8"-90° Angle Connector for Sealite Conduit	1-5
A842	Style 27, 1/2"-90° Angle Connector for Sealite Conduit	5

When ordering parts, always give serial number of the machine.

Part Number	Description	Plate Number
915	Style 3, 3/8"-16 x 1" Long Hexagon Head Cap Screw	3
977-A	Style 44, 10-32 x 1/4" Long Cone Point Hexagon Socket Set Screw	
1161	Style 7, 10-32 x 3/8" Long Round Head Screws	3
1276 1/2	Micrometer Thimble Stop Screw	2
1354 1/2	Style 4, 6-32 x 1/8" Headless Cup Point Set Screw	4
1379 1/2	Style 2, 10-32 x 1/2" Long Oval Filister Head Machine Screw	
1382	Style 2, 10-32 x 3/8" Long Oval Filister Head Machine Screw	2
1535	Style 201, .260" L.D. x 11/16" O.D. x .048" Thick Stainless Steel Washer	
1670 1/2 A	Style 56, 3/16" Rd. x 1/2" Long Dowel Pin	2
1694 1/2	#10-32 x 3/16" Long Headless Cup Point Set Screw	
1790	Style 44, 1/4"-20 x 1/4" Long Hexagon Socket Cup Point Set Screw	2
6001	Micrometer Handle	2
	Micrometer Handle Pin—use S-135	
A6002B	Micrometer Thimble Assembly (Inch graduations)	2
6002B	Micrometer Thimble (Micrometer Thimble Stop Screw—use 1276 1/2)	2
AC-6002B	Micrometer Thimble Assembly (mm. graduations)	2
6002 1/2	Micrometer Thimble Graduated Plate (Inch graduations)	2
C6002 1/2	Micrometer Thimble Graduated Plate (mm. graduations)	1
6003	Style 45, Micrometer Thimble Screw	2
6003 1/2	Style 44, 1/4"-28 x 1/4" Long Hollow Hexagon Set Screw	2
6004 1/2	Micrometer Spacer Set Screw Shoe	2
6006-A	Small Bearing	4
6007-A	Large Bearing	4
6008-A	Spindle Shaft	4
6009-A	Micrometer Spacer (Micrometer Spacer Taper Pin—use 6307)	2
6009 1/2	Adjusting Spacer Collar	2
A6010A	Micrometer Adjusting Screw Assembly (Micrometer Adjusting Screw Lock Washer—use 158)	1
6010A	Micrometer Screw (Micrometer Screw Adjusting Screw—use 6185)	2
6011A	Spindle Housing Lock Screw	1
6012A	Spindle Housing Lock Screw Handle (Spindle Housing Lock Screw Handle Set Screw—use 1694 1/2)	1
6013	Gib	
6014-B	Spindle Dovetail Plate (Spindle Dovetail Plate Screws—use 807 (Spindle Dovetail Plate Pins—use 298)	
6015-B	Spindle Pulley for 1725 rpm Motor (2 1/4" Dia.) (Spindle Pulley Nut—use 6180 (Spindle Pulley Key—use 6181)	1-4
6016-B	Spindle Housing (Spindle Housing Screw—use 6075)	
A6017	Belt Guard & Plate Assembly	
6017	Belt Guard (Belt Guard Screws—use 67)	1
6018B	Belt Guard Plate (Belt Guard Plate Screws—use 171)	2-3

Part Number	Description	Plate Number
6020-A	Front Cap	3
	Front Cap Screws — use 171	
6021	Cutter Guard	1
6023-B	Spindle Pulley for 1425 r.p.m. Motor (2-5/16" Dia.)	
	Spindle Pulley Nut — use 6180	
	Spindle Pulley Key — use 6181	
6027	Slug Oiler Arm	4
	Slug Oiler Arm Nut — use 95	
6028-A	Slug Oiler Stud	4
6029-A	Slug Oiler Stud Nut	4
	Slug Oiler Stud Nut Screw — use 1354½	
6030	Slug Oiler Plunger	
	Slug Oiler Plunger Spring — use 372	
6031	Slug Oiler Arm Fulcrum	4
	Slug Oiler Arm Fulcrum Adjusting Screw — use 659½A	
	Slug Oiler Arm Fulcrum Adjusting Screw Nut — use 230	
6032	Slug Oiler Stud Fulcrum (Upper)	4
6034	Slug Oiler	4
6035	Slug Oiler Stud Nut Plug	4
6036	Gib Screw	
6038-A	Slug Oiler Felt Washer	4
6039	Slug Oiler Stud Fulcrum (Lower)	4
6041	Oil Cup Wicking	
6049	Style 44, ¼" - 20 x 5/16" Long Hexagon Socket Cup Point Set Screw	
6050	Belt	1
6051	Motor Pulley for 1725 rpm Motor (5¾" Dia.)	1
	Motor Pulley Set Screw—use 681½	
6051½	Motor Pulley for 1725 rpm Motor (Keywayed Shaft)	
	Motor Pulley Set Screw—use 6049	
6052-A	Column	1
6052½A	Motor Bracket	3
	Motor Bracket Screw—use 915	
A6053-A	Portable Cord & Plug Assembled	5
	(For 110-volt Motors only)	
6053½	Motor Shims (used with Form G Motors on oldstyle bases only)	
A6054A	Electric Wiring Assembled	
6054A	Unilet Box	5
	Unilet Box Cover—use A124½	
	Unilet Box Cover Gasket—use 123½	
6056-A	Slug Tray Holder	1
	Slug Tray Holder Screws—use 6056½	
6056½	Style 45, 5/16" - 18 x ½" Long Button Head Socket Cap Screws	
6057	Slug Tray Holder Bracket	1
	Slug Tray Holder Bracket Screws—use M-210	
6058-A	Table	1
	Table Mounting Screws—use 6132-A	
A6062	Chip Pan Assembly	1-3
6062	Chip Pan	
	Chip Pan Handle—use 6063	
6063	Chip Pan Handle	
A6065-A	Separable Plug	
	(For 110V-AC only)	
A6065½	Cord Plug Adaptor	

When ordering parts, always give serial number of the machine.

Part Number	Description	Plate Number
6066	Brush	1
	Brush Ring—use 6073	
6067	Chip Pan Bracket	1-3
	Chip Pan Bracket Screws—use 451	
6068	Brush Chain	1
6070	Motor Pulley—1425 rpm (5-15/16" Diameter) Motor Pulley Set Screw—use 681½	
6070½	Motor Pulley—1425 rpm—5/8" Dia. Keyway Bore	
6071-A	Style 22, Unilet to Switch Conduit	1-5
6072-A	Style 22, Unilet to Motor Conduit	1-5
6073	Brush Ring	1
6075	Spindle Housing Screw	1
6101	Upper Cam Roll	2
6102	Lower Cam Roll	2
6103	Cam Roll Arm	2
6105	Bumper Screw	2
6106	Clamp Equalizing Bar Fulcrum Screw	1-2
6107	Bumper	2
	Bumper Springs—use 445-A	
6109	Lower Cam Roll Stud	2-3
	Lower Cam Roll Stud Nut—use 562	
6110-B	Carriage Rod Wiper Stud	
6111-B	Carriage Rod Wiper	1
6112-A	Upper Cam Roll Stud	2
6113-A	Cam Roll Arm Fulcrum Screw	2
6114-A	Carriage Slide Rod	1-3
6115	Slug Rest	1-2
	Slug Rest Screws—use 1382	
	Slug Rest Stop Pins—use 1670½A	
6116-B	Carriage Slide Plate	2
	Carriage Slide Plate Screws—use 6133	
6117-A	Style 45, ¼"-28 x 1½" Hexagon Socket Head Cap Screws	2-3
A6118-B	Carriage Body Assembled	
	Slug Rest Adjusting Screws—use 604-A	
	Cam Roll Arm Stop Pin—use 452	
6118-B	Carriage Body	2-3
	Slide Rod Wear Adjusting Screws—use 6117-A	
6119-A	Carriage Clamp	1-2
	Carriage Clamp Handle—use 6123	
	Carriage Clamp Handle Set Screw—use 1790	
6119½	Cutter Face Guard	2-3
6120-A	Clamp Fulcrum Rod	
	Clamp Fulcrum Rod Collar—use 6194	
	Clamp Fulcrum Rod Screw—use 6195	
6121	Clamp Fulcrum Rod Set Screw	
6122-A	Clamp Spring	3
	Clamp Spring Screws—use 1161	
6123	Carriage Clamp Handle	1-2
6124-A	Slide Rod Block (Front)	1-3
	Slide Rod Block Screws—use 6135	
	Slide Rod Block Dowel—use 13	
	Slide Rod Block Set Screw—use 6128	
	Slide Rod Block Set Screw—use 6178	
6125	Clamp Equalizing Bar	1-2

Part Number	Description	Plate Number
	Clamp Equalizing Bar Screw—use 6106	
	Clamp Equalizing Bar Screw Check Nut—use 562	
6126	Cam Roll Arm Spring	2
6127	Cam Roll Arm Spring Post	2
6128	Style 4, 1/4"-20 x 3/8" Long Round Point Slotted Headless Set Screw	
6129	Carriage Cam	3
	Carriage Cam Screw—use 1379 1/2	
6132-A	Style 45, 1/2"-13 x 3" Long Socket Head Cap Screw	
	1/2"-13 Hexagon Socket Cap Screw Key—use FG-38	
6133	Carriage Slide Plate Screw	2
6134-A	Slide Rod Block (Rear)	3
	Slide Rod Block Screws—use 6135	
	Slide Rod Block Dowels—use 13	
	Slide Rod Block Set Screws—use 6128	
	Slide Rod Block Set Screws—use 6178	
6135	Style 45, 1/2"-13 x 2 1/2" Long Socket Head Cap Screw	
	1/2"-13 Hexagon Socket Cap Screw Key—use FG-38	
A6151	Cutter Assembly	4
	Cutter Mounting Screws—use 6154	
6151	Cutter Body	
	Cutter Blades—use 6152	
	Cutter Blade Set Screws—use 6153	
6152	Cutter Blades	4
6153	Style 44, 10-32 x 5/16" Long Hexagon Socket Full Dog Point Set Screws	
6154	Style 45, 1/4"-20 x 3/4" Long Hexagon Socket Cap Screws	
6155-A	Lubrication Plate	1
	Lubrication Plate Pins—use 37 1/2	
6156	Name Plate	1
	Name Plate Pins—use 37 1/2	
A6157	Cutter Box Assembled	
	Cutter Mounting Screws—use 76	
6157	Cutter Box	
6157 1/2	Cutter Mounting Plate	
	Cutter Mounting Plate Screw—use 171	
	Cutter Mounting Plate Screw Washer—use 1535	
6158	Caution Name Plate	1
	Caution Name Plate Pins—use 37 1/2	
A6159	Felt Oil (In 6161 can and 6164A Label)	
6159	Felt Oil	
A6160A	Spindle Oil (For Replacement Sales and shipped with Rebuilt Machine Serial No. 706 and under)	
6160A	Oil (For Replacement Sales only, Machine Serial No. 706 and under)	
6161	Oil Can	
6162	Spout for Oil Can	
6163	Brush Chain Clip	
	Brush Chain Clip Screw—use 1161	
6164-A	Label for A6159 (Felt Oil)	
6165-A	Label for A6160-A (Spindle Oil)	
6171	Micrometer Thimble Screw Seat	
6172	Oil Cup	3
	Oil Cup Wicking—use 6041	
A6173-A	110-Volt Cord Grip	3-5
A6174-A	Switch to Motor Wire and Terminals Assembled	5
	Terminals—use 748 1/2 EA	

When ordering parts, always give serial number of the machine.

Part Number	Description	Plate Number
A6175-A	Unilet to Switch Wire and Terminals Assembled	5
	Terminals—use 748 $\frac{1}{2}$ EA	
6176	Motor Pulley—1140 rpm (6 $\frac{1}{8}$ " Dia.) Motor Pulley Set Screw—use 681 $\frac{1}{2}$	
6176 $\frac{1}{2}$	Motor Pulley—1140 rpm— $\frac{5}{8}$ " Dia. Keyway Bored Motor Pulley Set Screw—use 6049	
6177-A	Spindle Pulley—1140 rpm Motor (1-31/32" Dia.) Spindle Pulley Nut—6180 Spindle Pulley Key—use 6181	
6178	Style 4, $\frac{1}{4}$ "-20 x $\frac{1}{4}$ " Long Round Point Slotted Headless Set Screw	1
6180	Style 101, $\frac{1}{2}$ "-24 x $\frac{3}{8}$ " Thick Hexagon Nut	4
6181	Style 14, No. 5 Woodruff Key	4
6185	Style 1, $\frac{1}{4}$ "-28 x $\frac{1}{2}$ " Long Flat Filister Head Screw	
6194	Clamp Fulcrum Rod Collar	2
	Clamp Fulcrum Rod Collar Taper Pin—use 977-A	
6195	5/16"-18 x $\frac{1}{2}$ " Long Special Filister Head Screw	2-3
6197	Spring Retainer	4
6198	Spring Retainer Washer	4
6199	Spindle Springs	4
6307	Style 55, #0 x $\frac{7}{8}$ " Long Taper Pin	2

Ludlow Supersurfacers

Plate 1

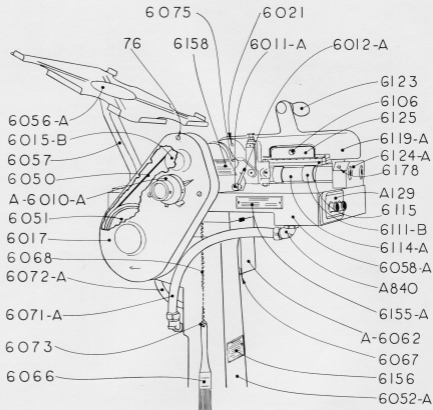

Supersurfacers, Side View

Plate 2

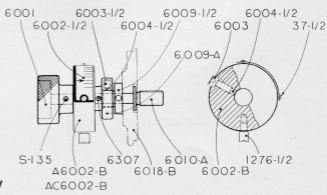
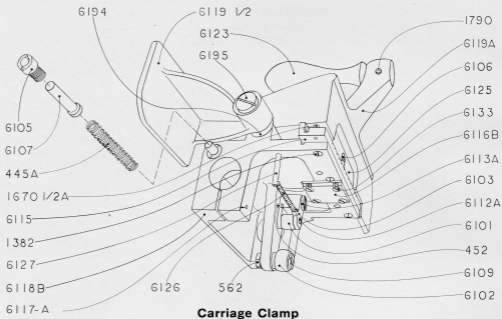
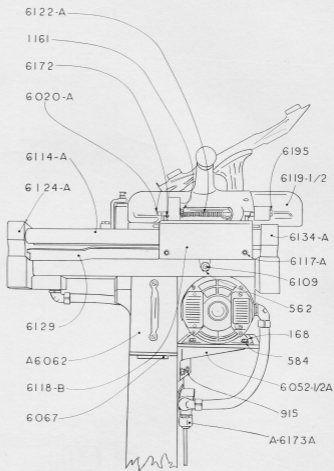

Plate 3



Right Side View

Ludlow Supersurfacers

Plate 4

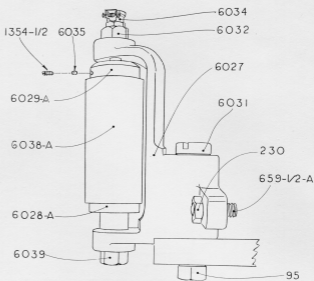

Slug Oiler Assembly

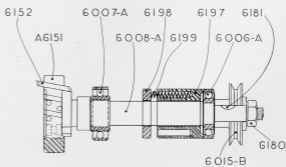

Spindle Assembly

Plate 5

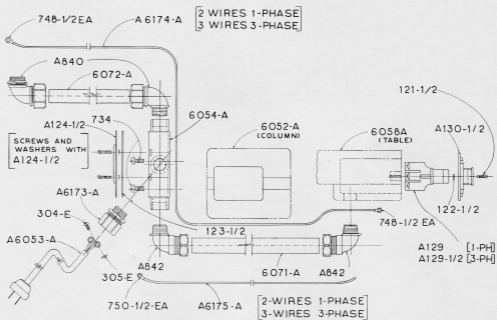

Electrical Equipment

Style Chart



STYLE 1



STYLE 2



STYLE 3



STYLE 4



STYLE 5



STYLE 7



STYLE 8



STYLE 14



STYLE 44



STYLE 45



STYLE 55



STYLE 56



STYLE 57



STYLE 101



STYLE 102



STYLE 201



STYLE 202

