

---

# LUDLOW

Manual of Instructions  
WITH LIST OF PARTS - No. 10

---

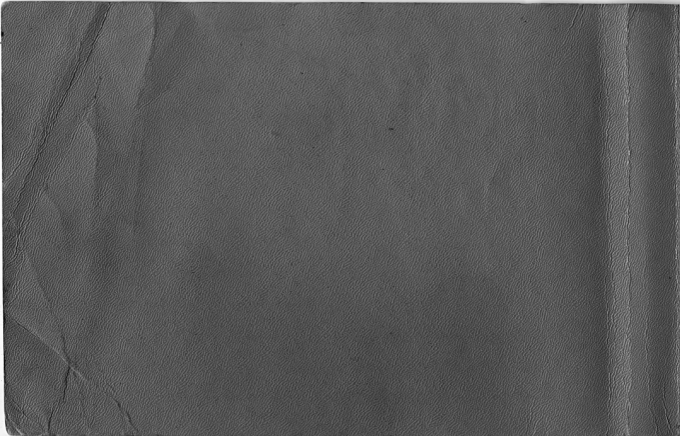

Sept 1958

Plunger spring pressure.  
10 Picas

---

check for mouthpiece slot  
- must center -

---

check height of plunger

---

check front legs of machine  
start with 12 pt. up to  
36 points.



Sept. 1958

# LUDLOW MANUAL OF INSTRUCTIONS

WITH LIST OF PARTS

10th Edition

5976 North Northwest Highway.  
60631

## LUDLOW TYPOGRAPH COMPANY

~~2032 Clybourn Avenue~~, Chicago 14, Illinois

120 Marietta Street	470 Atlantic Avenue	589 Fifth Avenue	5 Third Street
Atlanta 3, Ga.	Boston 10, Mass.	New York 17, N. Y.	San Francisco 3, Cal.

Cable Address: LUDTYPE, CHICAGO

1-312-792-2333

1-800-631-6024

THE HISTORY OF THE  
CITY OF BOSTON

BY SAMUEL JOHNSON  
VOL. I

NEW YORK: PUBLISHED BY  
JOHN WILEY & SONS, 15 N. ASSATEZ ST.  
1893

# How to Order Parts

1. Look up part wanted on Plates 1 to 40 in order to obtain part number.
2. Look up part number in numerical index at back of book. This will refer to page number of parts list containing name of part, and code name if ordered by cable or telegraph.
3. Small parts not illustrated are a part of a larger unit which is illustrated. Look up the larger unit per instructions in 1 and 2 above. The small part will be found listed with the larger unit. For example, Plate 27 shows style numbers of bolts, screws, nuts, dowels and washers. This illustration will assist in identifying these small parts.
4. When ordering parts, give part number and name, and serial number of machine.
5. When ordering electrical parts, give the voltage, and state whether the current is alternating or direct. Also give cycles of alternating current.
6. Please specify whether shipments are to be forwarded by first class mail, air mail, parcel post, air express, express or freight.

Place your machine Serial Number  
here, for convenience in ordering parts:

Serial No. 11703.....

# Table of Contents

## Care and Maintenance

Proper Seating of Ludlow.....	7
Oiling.....	7
Maintenance Schedule.....	8
Cleaning the Plunger and Well.....	8
Care of Mouthpiece.....	9
Metal Level in the Crucible.....	10
Care of the Metal.....	10
Water Cooling System.....	10
Machine Must Be Kept Clean.....	11
Care of Matrices and Spaces.....	11

## Adjustments

Safety Mechanisms.....	12
Safety Key.....	12
Main Slide Height Adjustment.....	13
Stick Locking Mechanism Adjustment.....	13
Stick Stop Adjustment.....	14
Locking Slide Adjustment.....	14
Mouthpiece to Mold Adjustment.....	15
Crucible Adjustment.....	15
Crucible Swivel.....	17
Crucible Compression Adjustment.....	17

Centering Mouthpiece Opening with Mold.....	17
Plunger Height Adjustment.....	17
Plunger Cam Adjustment.....	18
Table Latch Adjustment.....	18
When Machine Stalls in Casting Position.....	19
Ejector Blade.....	20
Delivery Slide.....	20
Metal Mold Wiper.....	21
Water Pump.....	21

## Gas-Heated Crucible

Gas-Heated Crucible.....	22
--------------------------	----

## Electrically-Heated Crucible

Crucible Heater Circuit.....	23
Thermostat Circuit.....	23
Throat and Mouth Heater Circuit.....	24
Motor Circuit.....	24
Fuses.....	24
Machine Must Be Grounded.....	24

## To Locate Electrical Trouble

Test Lamp.....	25
----------------	----



## Table of Contents (Continued)

How to Use the Test Lamp.....	25	Plate 4 — Main Shaft, Cams and Safety Mechanism — Top View with Table Top Removed.....	33
Trouble Indications.....	25	Plate 5 — Table Top Parts.....	34
Control Panel Test.....	26	Plate 6 — Table Top Parts — Cross-sections where small springs are located.....	35
Control Panel Ground Test.....	26	Plate 7 — Locking Down Parts.....	36
Open Circuit Test.....	26	Plate 8 — Mold Cooling System.....	37
Magnetic Switch Operating Test.....	26	Plate 9 — Mold — Double Water-Cooled.....	38
Magnet Coil Test.....	27	Plate 10 — Electric Crucible Cross-section.....	39
Magnetic Switch Breaker Contact Inspection.....	27	Plate 11 — Indicating Thermostat.....	40
Crucible Heater and Circuit.....	27	Plate 12 — Electric Crucible Heating and Control Parts with Wiring Diagram.....	41
Thermostat Circuit Test.....	27	Plate 13 — Electric Crucible Control Panel.....	42
Thermostat Adjustment.....	28	Plate 14 — Rheostat.....	43
Throat Heater Test.....	28	Plate 15 — Crucible Operating Mechanism.....	44
Mouth Heater Test.....	28	Plate 16 — Crucible Swivel and Crucible Adjusting Parts.....	45
Rheostat Test.....	28	Plate 17 — Belt Guard.....	46

### Illustrations

Figure 1 — Test Lamp.....	25	Plate 18 — Gas Crucible.....	47
Plate 1 — Front View of Machine — With Table Top Raised & Delivery Slide Removed.....	30	Plate 19 — Gas Machine and Connections — Rear View.....	48
Plate 2 — Right End View of Machine.....	31	Plate 20 — Main Slide.....	49
Plate 3 — Clutch Mechanism.....	32		

## Table of Contents (Continued)

Plate 21 — Main Slide Parts .....	50
Plate 22 — Ejector and Bottom Trim Slide Parts .....	51
Plate 23 — Delivery Slide—Top View .....	52
Plate 24 — Delivery Slide—Bottom View .....	53
Plate 25 — Mouthpiece Wiper .....	54
Plate 26 — Accessories, Tools and Supplies .....	55
Plate 27 — Style Chart of Screws, Nuts, Pins and Washers .....	56
Plate 28 — Loose Side, 6-LP and Italic Matrix Sticks .....	57
Plate 29 — Loose-Side Two-Slug Matrix Stick .....	58
Plate 30 — Self-Quadding Matrix Sticks .....	59
Plate 31 — Adjustable Offset Matrix Stick .....	60
Plate 32 — Mandate Matrix Stick .....	61
Plate 33 — Self-Centering Matrix Stick .....	62
Plate 34 — Division Quads and Division Quad Clamp .....	63
Plate 35 — Space and Quad Trays and Division Quad Tray .....	64
Plate 36 — Matrix Stick-Board and Stick-Rack .....	65
Plate 37 — Slug Trays .....	66
Plate 38 — Universal Matrix Cabinet .....	67
Plate 39 — Angle Top Matrix Cabinet .....	68
Plate 40 — Automatic Metal Feeders .....	69

## List of Parts

Frame and Table Parts .....	70
Driving Mechanism .....	76
Mold Cooling System Parts .....	81
Crucible Mechanism Parts .....	84
Gas Crucible and Parts .....	91
Electric Crucible and Parts .....	96
Electric Crucible Thermostat and Parts .....	102
Tripping Mechanism .....	103
Locking Mechanism .....	106
Main, Bottom Trim, Ejector & Delivery Slide Parts .....	111
Stick Stop and Safety Mechanism Parts .....	120
Mouthpiece Wiper and Parts .....	123
Galley and Slug Pusher Parts .....	124
Plunger and Well Cleaning Tools and Parts .....	126
Accessories, Tools and Supplies .....	127
Molds—Double Water-Cooled .....	129
Matrix Sticks .....	130
Division Quads, Division Quad Clamps, etc. ....	134
Matrix Cabinets, Space Trays and Parts .....	135

## Numerical Index

Numerical Index .....	138
-----------------------	-----

# Care and Maintenance

It will be apparent to even the most casual observer that the Ludlow Typograph machine is of rigid construction, has relatively few moving parts, and that the few simple adjustments that may be necessary to maintain its satisfactory operation are easily made.

## Proper Seating of Ludlow

In placing the Ludlow in position, see that the legs are even and do not create a twist in the frame. Raise the left leg of the machine  $\frac{1}{8}$ " off the floor by means of a jack or block and wedge placed under the cross member of the leg immediately to the left of the water tank drain cock. Place a piece of paper beneath each foot of the leg. Lower the machine until one of the papers is lightly gripped by one foot. Then place shims of leads or slugs under the opposite foot. Do not force shimming material in place. Then remove the jack or block and wedge.

## Oiling

The Ludlow Typograph machine should be thoroughly oiled twice each week, excepting the motor.

New motors are oiled and inspected at the factory and, for normal service, should not need additional oil during the first year. Add 40 to 70 drops of a good light oil (SAE-20) or medium (SAE-30) mineral lubricating oil at the end of six months use, if used on a double shift, or at the end of one year if used on a single shift, or after 1,000 hours of service. Over-oiling is as undesirable as under-oiling.

There are 14 oilers on the machine, one (15A) being shown on Plate 16; also 10 oil holes, three on the delivery slide, one on the stick stop slide, one on the lock release catch, one on the table catch, and four on the crucible hinges, where oil should be applied. Use a good grade medium machine oil.

The operator should make a practice of oiling the machine systematically, starting from the same place each time. By going through the same routine, only a few minutes will be required to lubricate the machine thoroughly.

The oiler in the rear of the Crucible Cam Lever, 224ED, should be filled each day with Ludlow Lubriclean Fluid, A945A, Plate 26. Use Lubriclean for all moving parts on the crucible which are subjected to

heat, as this is a special preparation which will remain on the heated parts for a longer period of time than will ordinary lubricants.

The Felt Mouthpiece Wiper, 805D, is treated with a special lubricant and should not require any additional oiling.

Ordinary oil is not recommended for the felt wiper, as it will carbonize and fill the mouthpiece air vents and obstruct the opening of the mouthpiece with a deposit which is difficult to remove.

## Maintenance Schedule

*Every day:* Oil Crucible Cam Lever, 224ED.

*Twice a week:* Put oil in 14 oilers and 10 oil holes. Clean plunger and well.

*Once a week:* Clean entire machine.

*Once a month:* Remove mouthpiece and clean mouthpiece and throat.

## Cleaning the Plunger and Well

X Free movement of the plunger in the well is dependent upon the thorough cleaning of these parts at least twice each week or oftener. A Plunger and Well Cleaning Kit, A951, is available for this purpose.

When cleaning the plunger and well, remove crucible cover on electric crucible, and then cover the mouthpiece with the Mouthpiece Opening Shield, A504, Plate

26, to prevent the hot metal from splashing out of the mouthpiece when the plunger or well cleaning tool is being inserted into the well.

To clean the plunger, remove it from the crucible, using the combination Holder for the Plunger and Crucible Well Cleaner, A992A, Plate 26. While the plunger is still hot, wipe off the metal and loose deposits adhering to the outer surface and apply a light application of Lubriclean Fluid, A945A, with the asbestos swab. Allow the fluid to remain on the plunger approximately two to three minutes before brushing off with a wire brush and wiping clean with a cloth. If a hard deposit in the form of a ring is noticed on the upper area of the plunger, it can best be removed with a strip of fine emery cloth.

Immediately after removing the plunger from the crucible for cleaning, place the Crucible Well Cleaner, A992½ A, Plate 26, in the molten metal of the crucible (not in the well), to allow the tool to preheat to the temperature of the type metal, so it will be ready for immediate use when the plunger has been cleaned.

To clean the well, skim dross from surface of metal, assemble the preheated well cleaning tool to the holder, A992A, Plate 26. Drop 8 or 10 drops of Lubriclean Fluid in a pool on top of the metal immediately over the well and insert the cleaning-tool in the well and work it in an oscillating and up-and-down motion.

Wipe  
Brush

The oil on the surface of the metal will transfer to the cleaning tool and keep it lubricated. Remove the cleaning tool frequently to wipe off the dross, continuing this operation until the well is cleaned. If the well has not been cleaned regularly, it may be necessary to apply the fluid to the top of the metal two or three times during the cleaning operation.

Before replacing the plunger in the well, skim the dross and Lubriclean residue from the surface of the type metal. Apply a thin coating of Lubriclean to the plunger, and see that it floats freely in the well before assembling it to the plunger lever.

If well has not been cleaned regularly, it may be necessary to be certain the above cleaning operation is adequate. Dip metal out of the crucible until metal level exposes top of well. Insert plunger and *slowly* push it down as far as it can go and see if it rises by itself. If it does not rise freely, repeat cleaning operation.

Care should be taken not to drop or bump the plunger or the well cleaning tool against a hard object, as this may mar or upset the surface of these parts, with resultant damage to the well.

If the well cleaning tool becomes ineffective, the four segments can be expanded slightly by careful use of a screw driver or like tool to spring the segments farther apart.

Special patented preparations and tallow should be

avoided as a lubricant or cleaner for plunger and well.

Failure to keep the plunger and well clean will invariably result in an unsatisfactory printing face and porous slugs.

## Care of Mouthpiece

The grayish-black deposit which accumulates on the vented surface and in the slot of the mouthpiece can easily be removed when hot by the use of Ludlow Lubriclean Fluid, A945A. The fluid is applied on the vented surface and in the slot of the mouthpiece and allowed to remain for two to three minutes, when the slot may be scraped clean with the Mouthpiece Slot Scraper, A939B, Plate 26, and the surface brushed clean with a wire brush before removing mouthpiece for a thorough cleaning of the throat.

It is advisable to remove the mouthpiece from the crucible at least once a month to clean the lower part of the mouthpiece and to scrape the side walls of the crucible throat. When cleaning the crucible throat, either reduce the metal level 3" by bailing, or tilt the crucible back by lifting the front end sufficiently for the insertion of a 7-pica block between the bottom of the crucible and the machine frame. To prevent molten metal from entering the screw holes, it is best to replace the mouthpiece screws before scraping the throat of the

crucible. With the crucible prepared as above, the Crucible Throat Scraper, A939½B, Plate 26, should be used to scrape the walls of the throat.

After scraping, remove all loose dross from the throat before reassembling the mouthpiece to the crucible. When assembling the mouthpiece to the crucible, the screws should be treated with graphite, to insure their easy removal, but do not pack graphite into the screw holes. After the mouthpiece has been assembled to the crucible, cast several blank slugs to thoroughly clean the throat before casting typeface slugs.

## Metal Level in the Crucible

Always try to keep metal level approximately ¼" below the top at the back of the crucible. If the metal level is permitted to drop below the top of the heating elements, these elements, when heated, will be damaged by their exposure to the air. A low level will also have considerable effect on the solidity of the slug. If the crucible is filled to the brim, the metal will overflow at the mouthpiece and may cause improper lockup between mouthpiece and mold, resulting in a metal splash when casting. The metal level may be more accurately regulated by the use of an automatic metal feeder.

## Care of the Metal

To secure best results, the attention given the metal

used in the Ludlow crucible should be the same as that given to other slug or typecasting machines. Metal which contains improper proportions of lead, tin and antimony, or which is contaminated with copper, zinc, or other foreign substance, will cause considerable trouble. An indication of this trouble will appear in a poor printing face on the slug. In some cases these impurities will form obstructions in the throat and mouthpiece and make it impossible to obtain a satisfactory slug. Any of the leading metal companies will gladly furnish an analysis of the metal from a sample and will advise you of its condition. About a pound of metal will be necessary for proper analysis and this sample may be obtained by casting blank slugs.

It is not intended that any metal other than either standard Ludlow or standard Linotype metal be used in the Ludlow crucible. Standard Ludlow metal contains 6% tin, 11½% antimony, and the balance lead. Standard Linotype metal contains 4% tin, 11½% antimony and the balance lead. Trouble may be expected when the tin drops below 3¾%, or when the antimony drops below 11¼% or goes over 12%.

Type metal should not contain copper or zinc, and only a trace of arsenic.

## Water Cooling System

In some localities the water contains a considerable

amount of lime and other alkalies which will rust and clog the mold and pump, impairing the efficiency of the cooling system. Where this condition is present, always use soft water in the tank. The Soluble Oil, AM254, Plate 26, should be added to the tank of water.

The tank should be kept filled to within one inch of the top. If, through leakage or evaporation, or because the water has become stagnant, it becomes necessary to replace the water in the tank, always add this soluble oil to the water. This oil tends to keep the tank, molds and piping from rusting and serves as a lubricant for the moving parts of the pump.

## Machine Must Be Kept Clean

The greatest cause of trouble results from failure of the operator to keep his machine clean. As with all hot metal machines, satisfactory operation depends upon perfect contact between matrices, mold and mouthpiece. If particles of metal or other foreign material adhere to the mold, the mouthpiece or the matrices, this perfect contact will not be had; or if particles of metal, such as trimmings, etc., become lodged in the cams, trouble will inevitably result.

The foreman in charge of a Ludlow Typograph machine will find that if some one person is made responsible for the maintenance of the machine and is allotted a certain time each day for this work, his effort will be repaid many times by increased production and freedom from repairs and replacements.

The operator should be provided with a stiff bristle brush to remove the particles of metal from the working parts, such as the cams, slides, etc. This should be done frequently. At least once each week the operator should clean the entire machine and remove all accumulations of dust and metal trimmings.

## Care of Matrices and Spaces

Ludlow matrices and spaces should be handled carefully at all times. Rough handling will shorten the life of matrices and spaces and cause the slugs to stick to the matrices in the casting operation, due to burrs on the face side of the matrices. Matrices, spaces and matrix cases should also be cleaned at regular intervals to remove dirt and particles of metal that may damage the sidewalls of the matrices.

# Adjustments

Before the machine leaves the factory, all of its parts have been tested and properly adjusted. However, after the machine has been in use for some time, it may become necessary to readjust some parts. The following instructions should be closely and carefully followed:

## Safety Mechanisms

Before making any adjustments, unlatch and raise the table with the hand lever on the left side of the machine. See that the Safety Finger, 753A, Plate 4, is over the end of the Plunger Cam Lever, A258. When the safety finger is in this position the plunger will not operate should the machine be turned on.

The Locking Slide Safety Pawl Bumper, 540C, Plate 5, is so designed that if the button on the stick or the division quad does not strike the bumper, the stick cannot be locked in place. The operator should see that this bumper does not become clogged with dirt or metal that might interfere with its operation.

The Locking Slide Safety Pawl, 579B, Plate 5, is so arranged that the stick of matrices must be pushed against the stick stop before the stick can be locked in

place to make a cast. This pawl should also be kept clean and free from dirt or metal that might interfere with its operation.

The Safety Operating Lever, 739A, is connected to the locking-down mechanism and operates the Safety Finger, 753A, permitting a cast to be made only when the stick is properly locked in position. This is an important safety feature, and care should be taken to see that these parts and parts connected to them, such as 732A, and parts 737B and 735A, Plate 1, and all of their attendant mechanisms are in perfect operating order. Particular attention should be given to Spring, 755, Plate 1, which is located on the under side of the table top and to Spring, 750½, Plate 4 (inside of tube), attached to the lower part of the mechanism just inside the frame in front of the crucible. These springs keep the safety mechanism in the non-casting position, and the machine should never be allowed to operate without them. Always observe the condition of these springs before making any other adjustments or repairs.

## Safety Key

The Safety Key, 155B, Plate 2, which connects the Driving Clutch Gear, 154A, with the Driving Clutch Shaft, 163B, Plate 2, is of such construction that any obstruction to the free turning of the machine will shear the safety key, thus safeguarding against breaking ex-



pensive parts of the machine. When this key shears off, replace it with a new one and back up the machine in order to locate and correct the cause of the shearing. Quite frequently this shearing will result from insufficient lubrication, dirt or metal trimmings accumulating in the cams, or by trimmings wedging in between the bottom trim knife slide and the main slide casting. It may also be caused by metal splashing out between the mouthpiece and mold, due probably to improper lock-up or by the failure of the mouthpiece wiper to clean off the mouthpiece properly. After the obstruction is located and removed, operate the machine carefully by hand to be sure that the cause of shearing the safety key will not recur.

## Main Slide Height Adjustment

To test the height of the Main Slide, 600, Plate 20, to which the mold is attached, first remove the right Safety Connecting Rod Stud, 746, and disconnect Safety Connecting Rod, 747A, Plate 5, then remove Table Latch Operating Stud, 77, Plate 20, and then raise the main slide to the highest point of its travel, but do not have the mouthpiece in contact with the mold. Place a blank slug block on top of the mold without being locked down, and see that the sides of the blank slug block are two points above the surface of the table top. Any adjustment of this height is made as follows:

Raise the table top, revolve the belt pulley by hand until the main slide has reached the highest point of its travel, but do not have the mouthpiece in contact with the mold. Loosen the Main Slide Adjusting Plate, 612A, Plate 20, located directly under the right hand side of the main slide, by means of Screw, 613A, using Wrench, A623½ furnished with the machine. Using two ⅝" x 4" drill rods for wrenches, loosen the two Check Nuts, 615 and 616½, and turn Adjusting Screw, 614, to either raise or lower the main slide. After the proper adjustment is made, carefully tighten the two check nuts and Adjusting Plate Screw, 613A.

Reassemble parts 77, 746 and 747A.

## Stick Locking Mechanism Adjustment

First, see that Table Latch Adjustment as described on page 18 is correct. Remove the Safety Connecting Rod, 747A, Plate 5. Then operate the machine by hand until the mouthpiece is in casting position under the mold, but is still ¼" away from it. Then take the special Height Gauge, A957, Plate 26, which is furnished with all machines, and lock it in position in the same manner as a stick of matrices or a blank slug block. Do not use a stick of matrices or a blank slug block for this adjustment. The Height Gauge, A957, is

the only correctly-dimensioned tool. Loosen Clamp Screw, 18, which is on the side of the Locking Equalizing Bar Clamp, 588A, Plate 5. Back out Adjusting Screw, 563A, Plate 5, until the rollers are free of the locking equalizing bar. Remove Locking Equalizing Lever Adjusting Screw Cap, 593½, and loosen the Check Nut, 230, on the Locking Equalizing Screw, 593, Plate 5, and back the adjusting screw until the Locking Equalizing Bar, A590B, is free of the height gauge. Then turn this screw, at the same time tapping the top of the equalizing bar with the finger until the equalizing bar makes full contact with the top of the height gauge. Then lock screw in place with Check Nut, 230. Insert a cigarette paper under each Roller, 596, Plate 5, and adjust Screws, 563A, Plate 5, until the paper is barely gripped by the rollers, yet can be pulled out without tearing. Tighten all clamp screws after these adjustments have been made.

## Stick Stop Adjustment

The stick stop should be so adjusted that when a line is cast the head of the slug is exactly even with the shank of the slug on the end farthest from the operator. This adjustment may be made by loosening the small Set Screw, 713A, Plate 6, in the top of the stick stop slide and turning the Adjusting Screw, 714, in or out until

the proper alignment is obtained, after which tighten the set screw. Check this adjustment by casting another line, using the same stick.

## Locking Slide Adjustment

When a stick of matrices is placed in the machine and locked in position, it is pushed against the Locking Guide, M575B, Plate 5, by the Locking Slide Shoe, 567, and the spring tension of the two Locking Slide Shoe Springs, 568, Plate 6. These springs sometimes become weakened after long usage and require replacement. If the head of the slug is not parallel to the shank, it may be that these springs do not have sufficient tension to hold the stick of matrices firmly against the locking guide at the time the cast is made, or that the locking guide itself is out of alignment.

The locking guide is adjustable so that the proper alignment of stick may be maintained at all times. To make this adjustment, the Locking Guide Screws, 576A, Plate 5, should be loosened, which will permit the turning of the Locking Adjusting Screws, 582B and 582½, Plates 5 and 7. Very little movement of these screws will be necessary to obtain the proper adjustment. Tighten the Screws, 576A, while the stick is locked in position.

If the locking guide has been put out of adjustment to the extent that the Locking Slide Safety Pawl

Bumper, 540C, Plate 5, does not operate properly, it will then be necessary to realign the guide from the mold slot. To do this, disconnect the Safety Connecting Rod, 747A, Plate 5. Remove Locking Equalizing Bar, A590B, Plate 5. Loosen the locking guide. Then raise the Main Slide, 600, Plate 20, to the highest point of its travel. Place a blank slug halfway into the mold slot. The distance between the blank slug and the locking guide should be  $5\frac{1}{4}$  picas (.954") when using a 12-point mold, and 6 picas (.996") when using a 6-point mold.

## Mouthpiece to Mold Adjustment

Revolve the belt pulley by hand until the mouthpiece is ready to come into contact with the mold. Slip a piece of paper between the mouthpiece and the mold and operate the machine by hand until the mouthpiece is locked up against the under side of the mold; then back up the machine a little until the paper may be removed. The impression on the paper will show whether the mouthpiece is resting solidly and evenly against the mold.

There are two ways in which the mouthpiece may be out of adjustment with relation to its proper seating against the under side of the mold. First, the crucible

may be tilted sidewise in such a way that the mouthpiece bears against the mold only along one side, and this condition is referred to in this section. Second, the mouthpiece may bear against the mold more on one end than on the other, the correction for which is explained under "Crucible Adjustment."

At the rear of the machine and located directly under the crucible, is the Crucible Swivel Bracket, 234A, Plate 16, fastened to the frame by two Screws, 236. Make sure the mouthpiece is not touching the bottom of the mold, loosen these screws slightly and then loosen the Check Nuts, 59, and turn that one of the two Adjusting Screws, 237, which will tilt the crucible in the desired direction. Very little movement of these screws is necessary—perhaps not over one-eighth turn. Make the test with the paper again to be certain that the adjustment is correct. The paper should show an even impression of both sides of the mouthpiece seat. Then tighten both Screws, 236, and the Check Nuts, 59.

After tightening these screws and nuts, test the lock-up again, as explained under "Stick Locking Mechanism Adjustment."

## Crucible Adjustment

In the upper right hand corner of the illustration on Plate 15 are illustrated two kinds of incorrect seating relations between mouthpiece and mold. Such incorrect

seating between the mouthpiece and the mold may be corrected by either lowering or raising the Crucible Swivel Bracket, 234A, Plate 5, as follows:

Check stick locking mechanism and rear table latch to be sure they are properly adjusted. Make sure the mouthpiece is not touching the bottom of the mold, then loosen both Screws, 236, just enough so that they still bear slightly on Bracket, 234A, and loosen both Check Nuts, 59. Turn both Screws, 237, equally to the left to remedy "A" condition. Turn both Screws, 237, equally to the right to remedy "B" condition. Then tighten both Screws, 236, and Check Nuts, 59. Very little movement of these screws will be necessary to correct the seating relations of these parts. To ascertain just when the mold and mouthpiece are in proper relation, insert a strip of tissue paper between the under side of the mold and the mouthpiece, and move the crucible to the casting position. The mouthpiece should leave an even impression on the paper, indicating that the mouthpiece is pressing against the mold equally on both ends. Check the Compression Bolt, 213B, Plate 15, to see that the Castellated Nut, 214A, is raised  $\frac{1}{32}$ " above its seat when in the casting position, as indicated at "C" on Plate 15.

Cast a few slugs, preferably 12-point, using the blank slug block. If the mouthpiece and mold are properly adjusted, the mouthpiece vent marks will show up

clearly along the bottom of the slug over its entire length, but if the mouthpiece and mold are not in proper relation, the vent marks will not be visible, and the bottom of the slug will be shiny, either wholly or in part. While casting test slugs, the mouthpiece should be wiped off carefully between each cast. If one end of the slug bottom is consistently shiny, it indicates that the corresponding end of the mouthpiece should be raised slightly.

Great care must be taken in making this adjustment, as it will probably never be necessary to move the Adjusting Screws, 237, over one-half turn.

After above adjustment has been taken care of satisfactorily, it is possible for it to shift in use if Adjusting Screws, 237, Plate 15, are not in proper position.

Referring to the illustration on Plate 15, lower right-hand side: See that both Crucible Swivel Bracket Screws, 236, are tight. Loosen Check Nuts, 59, on both Crucible Swivel Bracket Adjusting Screws, 237. Turn Adjusting Screw, 237, on right-hand side, so the *head* of the screw bears against the Crucible Swivel Bracket, 234A, as illustrated, and then tighten the Check Nut, 59. Turn Adjusting Screw, 237, on left-hand side so the *point* of the screw bears against the Crucible Swivel Bracket, 234A, as shown. Then tighten the Check Nut, 59. When this adjustment is performed properly, there will be a slight gap at points D and E.

## Crucible Swivel

The Crucible Swivel Nut, 232, Plate 16, should be just tight enough to resist any tendency of the crucible to rock, yet not so tight that it offers resistance to the turning of the Crucible Swivel, 231B, Plate 16. To adjust this nut, with crucible at rest position, remove the Crucible Swivel Nut Pin, 233, Plate 16, and turn this nut, using a metal rod, to the right to tighten, or to the left to loosen, after which replace Pin 233 in one of the two holes in Swivel, 231B, which is nearest in alignment with hole in Nut, 232.

## Crucible Compression Adjustment

To maintain the proper lock-up between the mouthpiece and the under side of the mold, the following adjustments must be carefully checked:

With the table top raised, operate the machine by hand until the mouthpiece is pressing firmly against the under side of the mold, which is in its highest position. At this point the Castellated Nut, 214A, Plate 15, should be in such position that it is raised  $\frac{1}{32}$ " above its seat, as shown at "C," Plate 15. This insures the proper pressure of the mouthpiece against the under side of the mold. This adjustment may be changed by removing the Cotter Pin, 219, Plate 15, and turning the

Castellated Nut, 214A, up or down until the proper location is reached, after which replace the corner pin.

## Centering Mouthpiece Opening With Mold

With the table top raised, operate the machine by hand until the mouthpiece has swung into position under, and is in compression with the mold. At this point the mouthpiece orifice should be exactly centered in the mold opening, and if not in the center, adjustment may be made as follows:

Swing up the Crucible Adjusting Bolt Guard, A215A, Plate 15, and loosen the two Clamp Screws, 250 $\frac{1}{2}$ , Plate 10, and the two Check Nuts, 230, Plate 10. Then unscrew one Adjusting Screw, 229, and screw in the other adjusting screw to give the desired location. For instance, if it is necessary to move the crucible to the left, unscrew the left-hand screw, screw in the right-hand screw the desired amount, after which tighten the left-hand screw until it bears against the Crucible Cam Lever, 224D, Plate 15. Then tighten the Check Nuts, 230, and the Screws, 250 $\frac{1}{2}$ , and lower the Guard, A215A.

## Plunger Height Adjustment

The plunger should be so adjusted that its bottom

edge is  $\frac{1}{16}$ " above the lower edge of the port in the well, as shown in Plate 15. This adjustment may be checked by removing the Cotter Pin, 68, and Pin, 275. This will permit the plunger to float in the well. A piece of wire  $\frac{1}{16}$ " in diameter should be bent into an "L" shape, so that one end may be inserted through the molten metal into the porthole of the well of the crucible, as shown on Plate 15. After the wire has been inserted through the porthole, the plunger should be pressed down upon the wire. With the plunger in this position, the hole in the Plunger Connecting Lever, 274A, should line up with the hole in the Connecting Rod, 271. If these holes are not in alignment, loosen Check Nut, 59, at the bottom of the Connecting Rod, 271, and turn the connecting rod up or down as required. After adjustment is completed, tighten Check Nut, 59, and replace all parts. Any variation from the correct setting of the plunger will result in hollow slugs, unsatisfactory face, or both.

## Plunger Cam Adjustment

The Plunger Cam, A254A, Plate 15, is made in two sections, one fixed and one movable. The movable section is clamped in place by two Screws, 256A. This cam, acting on the Cam Roll, 289, controls the upward stroke of the plunger after the cast has been made. By loosen-

ing the two Screws, 256A, the movable section of the cam should be so adjusted that the plunger rises just a fraction of a second before the mouthpiece leaves the under side of the mold on its return to normal position.

The standard adjustment of the movable cam is as follows: With the machine at rest position, loosen the two Screws, 256A, Plate 15. Swing the movable cam so there is a gap between the cam and Plunger Cam Shoe, 283. Measuring on outside diameter of the cam, this gap must be  $1\frac{1}{32}$ ", as shown in illustration. Then lock the two Screws, 256A.

## Table Latch Adjustment

The adjustment of the Table Latch, 86B, Plate 1, by means of which the table top is locked to the frame of the machine during the casting operation, should be made when the machine is in its idle position.

The Spring, 755, attached to that part of the table latch which is under the table top, should be removed and the table top should be lowered and locked down with the front Table Catches, A93A and 97, Plate 1. That part of the adjustable lock which projects through the top of the table may then be grasped and moved back and forth. If it moves very freely, the pawl should be raised, after loosening screws, and the notched eccentric bushing moved to the left by turning the knob one

notch at a time until the latch binds slightly when it is moved back and forth. The pawl should then be dropped into position and the screw which holds it in place tightened and the spring underneath the table replaced. If it is not possible to get the proper adjustment through the turning of the eccentric bushing, further adjustment may be made by raising or lowering that part of the Latch, 91B, Plate 1, which is attached to the main frame. To make this adjustment, the check nut should be loosened, which will allow the screw to be turned, thus raising or lowering Latch, 91B. The check nut should then be locked and the final close adjustment made with the eccentric bushing, as stated above.

During the casting part of the cycle, the automatic lock is in operation, locking the table down to the main frame of the machine. This latch is actuated by a Screw Stud, 77, Plate 20, which is fastened to the main slide by a bracket held in place with two screws. When the slide rises, this stud striking the diagonal side of the latch pushes it into position underneath the pin in the Latch, 91B. This stud is purposely made so that it will break in case there is some obstruction to the operation of the latch, protecting the more delicate parts of the locking mechanism. In the event the stud breaks off, the cause should be located and corrected and the stud replaced. Operate machine slowly by hand to see if the latch functions properly before turning on the motor.

## When Machine Stalls in Casting Position

In the event the machine should stall due to a hot metal flash just as the cast is being made, or has just been made, it will be necessary to raise the Table, No. 48, to investigate and correct the trouble, but before attempting to raise the table, *the following procedure is imperative:*

- (1) Throw the motor switch to the "off" position.
- (2) Remove the Safety Connecting Rod Stud, 746, which connects the Safety Connecting Rod, 747A, Plate 5. These parts are located on top of the table.
- (3) Lower Plunger Spring Adjusting Lever, 293A, Plate 2, to its lowest position.
- (4) Measure overall length of Plunger Spring, 263, Plate 2.
- (5) Loosen Check Nut, 59, Plate 2, at lower end of spring, then turn spring until its coils are completely closed. This will take all tension off the spring.
- (6) Remove Plunger Connecting Lever Pin, 275, Plate 10.
- (7) This should permit the plunger cam lever to be depressed enough so that the Safety Finger, 753A, Plate 4, may be positioned over the top of the projecting end of the plunger cam lever. It is most important

that the safety finger be positioned over the cam lever before any attempt is made to raise the table.

(8) Release the Rear Table Latch, 86B, Plate 1, by removing the threaded Table Latch Yoke Pin, 83A, Plate 4. The removal of this threaded pin is accomplished by inserting a long screw driver through the  $\frac{1}{2}$ " hole located on the rear side of the table near the center, and unscrewing the threaded pin, thereby releasing Table Latch, 86B.

(9) Release the front Table Catches, A93A and 97, Plate 1. The table may now be raised for observation of the location of the metal flashings.

(10) Remove all metal flashings from the movable parts as well as the interior of the machine generally.

(11) Add new Safety Key, 155B, Plate 2.

(12) Replace Plunger Connecting Lever Pin, 275, and with the spring adjusting lever in its lowest position, proceed to turn the spring to its original length and lock it in position with Check Nut 59.

(13) Reassemble all parts which have been removed.

(14) Operate the machine manually by pulling the belt at the front of the machine in a downward direction until the cam shaft returns to the neutral or idling position.

## Ejector Blade

If the Ejector Blade, A639A, Plate 22, is removed for

any reason, clean the shoulder upon which it rests very thoroughly before it is replaced, as any dirt or metal on this shoulder will tip the ejector and cause a drag on the ribs of the slug. The top surface of the ejector must be parallel with the mold.

## Delivery Slide

To adjust the Slug Holders, A663H and A664H, Plate 23, remove the slide from the machine by removing the Mouthpiece Wiper Bracket, A806J, which also retains the left side of the slide, and the Slug Carrier Operating Rack, A695A, which retains the right side of the slide. Turn the slide bottom side up, first making sure the Slug Holder Operating Plates, 645A, are not bent, then take two pieces of straight metal, such as 12-point slugs, and hold them firmly against the sides of the delivery slide casting so that they depress the Slug Holder Cams, A646A and A646 $\frac{1}{2}$ A. The slug holders should then be in a vertical position. If they are not in this position, loosen the Set Screws, 573, and turn the Adjusting Screws, 636 $\frac{1}{2}$ , until the proper adjustment is obtained, after which tighten the Set Screws, 573.

Adjust the two Screws, 669, in the Slug Holder Bearing Plate, 671G, so that the distance between slug holders, when closed, is approximately 13 points. Also, the two shoulders on the slug holders, on which the slug



rests, should be of the same height and on the center line of the opening in the delivery slide. Place the slide back in the machine, making sure that the Delivery Slide Pin, 696, fits into the slot in the upper end of Delivery Slide Lever, 651B, Plate 4, after which replace parts A806J and A695A.

## Metal Mold Wiper

After the machine has been in service for some time, the lower edge of the Metal Mold Wiper, 676D, Plate 24, may become rounded off to such an extent that the mold will not be wiped clean. To replace mold wiper, turn it one-quarter turn and remove it from under the head of the stud. Place new wiper under the head of the stud and turn until wiper snaps into place.

To adjust the Mold Wiper Arm, A678½B, operate the machine by hand until the mold has reached the highest point of its travel, at which point it should be possible to raise the mold wiper arm about two points. If this adjustment is not correct, loosen Check Nut, 230, located under mold wiper arm near its fulcrum, after which Adjusting Screw, 701, may be turned until the proper adjustment is obtained. Then tighten nut.

To adjust the mold wiper arm rest, operate the machine by hand until the delivery slide has reached the farthest point of its travel toward the rear of the ma-

chine and has started back to the front of the machine for a distance of 1 or 2 inches.

Loosen Check Nut, 230, Plate 23. Place a short piece of 2-point lead between Adjusting Screw, 696½, and Mold Wiper Arm, A678½B, and adjust the screw so it just bears against the 2-point lead. Then tighten the Check Nut, 230.

To adjust the Mold Wiper Arm Cam, 691½A, proceed as follows:

Operate the machine by hand until the delivery slide has reached the farthest point of its travel toward the rear of the machine, at which point Cam, 691½A, should have just been tripped by contact of the Screw, 980A, against the lug on the Mouthpiece Wiper Bracket, A806J. Any necessary adjustment may be made by loosening Nut, 325, and turning Adjustment Screw, 980, until the proper adjustment is obtained. Operate the machine slowly by hand before applying the power.

## Water Pump

The Water Pump, AM200H-1, Plate 8, is so mounted on the bracket that it can be moved up or down to adjust the tension on the Pump Belt, M223C, Plate 8. This belt and its two pulleys should be kept clean and free from oil, as this will cause the belt to slip.

A Strainer, M246, is placed in the water tank to keep

scale and other foreign material from entering the pump and perhaps cause it to bind. However, if the pump does stick, it can often be freed by turning the pulley back and forth a few times by hand.

Often the cause of the cooling system not functioning

properly is a plugged water line, which can be determined by inspecting the size of the stream of water flowing from the return pipe in the water tank. It is important to check the water flow occasionally, as it affects the solidity of the bottom of the slug.

## Gas-Heated Crucible

To obtain best results with a gas-heated crucible, be sure that the supply line is large enough so there will be no drop in gas pressure if the burners are turned on suddenly to their maximum capacity. Wherever possible, the Ludlow crucible should be connected to a supply line that has a pressure regulator.

There are two burners in the gas crucible: a Mouthpiece Burner (which is located under the throat and mouthpiece) and the Main or Base Burner directly under the crucible. The base burner is connected with the gas governor located at the top of the crucible, but the mouthpiece burner is controlled by the hand-operated valve.

The gas governor on the Ludlow crucible should, when it is properly set, maintain the temperature of the metal in the crucible from 550° to 565° F. If the tem-

perature in the crucible is not maintained between these points, adjustment may be made by turning the knurled screws on top of the governor in a clockwise direction to decrease and in a counter-clockwise direction to increase the temperature.

In some localities, the quality of the gas is such that after burners have been in use for some time they may become clogged. If air pressure is available near the machine, it is a good plan to blow out the burners and mixing valves every few weeks. Bellows may also be used for this purpose.

Do not place the machine in such a position that it will be subjected to severe drafts of air, as this will cause sudden variation of temperature in the crucible, due to the blowing of the flames.

# Electrically-Heated Crucible

The Ludlow Electric Crucible is so constructed and wired that the terminals, switches, fuses, etc., are readily accessible. By consulting the wiring diagrams on Plate 12, and by carefully following these instructions, anyone with a little electrical knowledge and mechanical inclination should be able to locate and correct any electrical trouble.

All terminals and wires are plainly marked and correspond to the markings as shown in the diagram on Plate 12.

The main feed wires enter the bottom of the control panel and are connected to the terminals at the top of the main hand switch, as shown on Plate 12.

From the main hand switch, the wiring is divided into four circuits, as follows: Crucible Heater Circuit, Thermostat Circuit, Throat and Mouth Heater Circuit, and Motor Circuit.

## Crucible Heater Circuit

From the two lower terminals of the main hand switch, the current passes through the crucible heater fuses, the magnetic switch, and then from terminals 3

and 4 to the two crucible heaters. The opening and closing of the magnetic switch is controlled by the action of the thermostat.

## Thermostat Circuit

This circuit is connected to terminals 5 and 6 in the control panel. The thermostat is fastened to the rear of the terminal box. From the thermostat a tube filled with mercury leads into the molten metal. As the temperature of the metal rises, the expansion of the mercury in the tube actuates a contact lever which opens Micro Switch 1425½ EA. This causes the automatic switch in the control panel to open, cutting off the flow of current to the crucible heaters.

As the temperature of the metal in the crucible decreases, the contact lever allows the Micro Switch to close, which closes the automatic switch and again sends current through the crucible heaters.

The thermostat is adjusted to maintain the temperature of the metal in the crucible approximately from 560° to 565° F.

## Throat and Mouth Heater Circuit

This circuit is connected to terminals 1 and 2 in the control panel and consists of a rheostat, a throat heater, and two mouth heaters. The rheostat is mounted on a bracket which is fastened to the rear of the machine. The purpose of the rheostat is to control the amount of current flowing through the throat and mouth heaters. When the indicator is at point "0" on the rheostat, the maximum amount of current is being delivered to the heaters. This gradually diminishes as the indicator is turned toward point "12."

The throat heater is located under the front of the crucible and is held against the throat of the crucible by asbestos padding, which is in turn held in place by a removable cover.

The two mouth heaters, which are of the cartridge type, fit in holes a little below and parallel to the mouth-piece, and are accessible through an opening in front of the crucible. This opening is closed by a removable sheet metal cover.

## Motor Circuit

From the two lower terminals of the main hand

switch, the current passes through the motor fuses, the motor switch, and then to the motor.

## Fuses

For 220 volt circuits the two crucible heater fuses should be of 10 ampere capacity, the throat and mouth heater fuses of 6 ampere capacity, and the motor fuses of 6 ampere capacity.

For 110 volt circuits the two crucible heater fuses should be of 20 ampere capacity, the throat and mouth heater fuses of 10 ampere capacity, and the motor fuses of 10 ampere capacity.

Many operating difficulties may result if larger capacity fuses are used than those specified.

## Machine Must Be Grounded

All of the following tests are based on the supposition that the machine is grounded. In most cases the machine is grounded by the line wire conduit. In case an adequate ground is not so established, it will be necessary to connect a No. 10 wire between the frame of the machine and a water pipe, or some other safe means of transmission to the ground. In order to make the following tests, it is absolutely imperative that the machine be grounded.

# To Locate Electrical Trouble

## Test Lamp

This test equipment consists of a red prod containing a neon glow lamp, and a black prod and attachment plug. When plug is in the receptacle as shown in illustration, it is short-circuited. Plug is taken out of this receptacle and plugged into 110 volt line for some tests, as indicated in following instructions.

The red prod containing the neon glow lamp is the live test point.

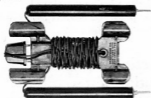

Fig. 1—Test Lamp, A932A

If, when the test lamp is connected to a receptacle, the neon glow lamp does not glow when the prod is grounded, remove the plug from the receptacle, turn over, and plug in again to obtain proper polarity.

## How to Use the Test Lamp

The test lamp may be used to locate a "ground," an "open circuit," a "short circuit," or a "dead" heating element. An explanation of these terms follows:

"Ground": A ground is the bare part of any electrical circuit accidentally touching the crucible or frame of the machine.

"Short Circuit": A short circuit is anything which allows the current to take a shorter path than intended.

"Open Circuit": An open circuit is an interruption in an electrical circuit, due to a break in the conductor, such as a broken wire or a loose connection.

"Dead Heater": A dead heating element is one having a broken or open circuit.

## Trouble Indications

When a fuse in the control panel is inoperative, it indicates one of the following: a ground, short circuit, or a fuse fitting too loosely in the fuse clips.

An open circuit, such as a broken wire, loose connection or burned out fuse, will prevent the heating of one or more of the heating elements.

## Control Panel Test

With test lamp short-circuited as shown in Figure 1, place one test point on terminal L-1 and the other on L-2. If the current reaches these terminals, the lamp will light. If the lamp does not light, test the main cut-out fuses.

Turn off the panel hand switch and remove the fuses. Place the fuse which is to be tested on a piece of dry paper or wood, then connect the test lamp to a lighting circuit and place a test point on each end of the fuse. If the fuse is in good condition, the test lamp will light. After the fuses have been tested, place them back in the panel and see that the clips grip them tightly. If these clips do not grip the fuses tightly, there is a possibility that the fuses will become heated, thereby lowering their capacity and causing them to burn out.

## Control Panel Ground Test

With the panel switch turned off, remove the crucible lead wires from terminals 1, 2, 3, 4, 5, 6, T-1 and T-2, and with the test lamp connected to lighting circuit, touch each of the terminals (1, 2, 3, 4, 5, 6, T-1 and T-2) in the control panel with the live point of the test lamp. If a light shows, it indicates a ground.

## Open Circuit Test

Turn on the panel hand switch and, with test lamp short-circuited as shown in Fig. 1, make the same test on terminals 1 and 2 which feed the throat and mouth heaters. This test should light the lamp.

Test the motor circuit by placing one test point on terminal T-1 and the other on T-2. This test should also light the lamp.

Next, test the terminals 3 and 4, which feed the crucible heaters. When the magnetic switch is closed manually, the lamp should light.

If the above tests fail to light the lamp, the failure may be due to a broken wire, loose connection in the back of the panel, or a defective hand switch. Inspect the hand switch contacts.

## Magnetic Switch Operating Test

Use a short length of insulated wire, the ends of which are bared. Place one end of the wire on terminal 5 and the other end on terminal 6. If the magnetic switch does not close automatically, proceed with the following tests:

## Magnet Coil Test

Connect the test lamp to the lighting circuit, turn off the panel hand switch and place a test point on each of the coil terminals. If coil is in good condition, the test lamp will light. If the magnet coil is found in good condition and following tests are OK, then look for a broken wire or a loose connection at the back of the panel. To remove the panel, remove the three screws which hold the mounting plate in the panel box.

With the panel hand switch turned on, if the switch closes when the test wire is placed on terminals 5 and 6, it should stay closed until the test wire is removed.

## Magnetic Switch Breaker Contact Inspection

If the breaker contacts are not clean, remove them from the armature and rub lightly on a piece of fine sandpaper. (Do not use emery cloth.)

To remove the movable contacts, lift up the Armature Retainer, 354EA, Plate 13, with the fingers until the notches clear the hinge frame, moving the armature retainer forward until it rests on the hinge frame. Lift the movable armature assembly from its seat and hinges. The breaker contacts can then be removed by depressing the spring and turning the contact on its

edge for easy removal. No tools are required to change the movable contacts. The stationary contacts are removed by the Screw, 359E, and sliding the contact to the front or rear.

## Crucible Heater and Circuit

Remove the terminal box cover, connect the test lamp to the lighting circuit and with the live test point of the test lamp touch wires 3 and 4. If a light shows it indicates a ground in the crucible heater or in wire 3 or 4. Place one test point on wire 3 and the other on 4. If the test lamp lights, the crucible heater is in good condition. No light will indicate a broken wire, loose connection or burned out heater. In such cases disconnect the wires so that each heating element may be tested independently for an open circuit.

## Thermostat Circuit Test

With the panel hand switch turned off, and the test lamp connected to the lighting circuit, place one test point on terminal 5 and the other on terminal 6 of the control panel. The test lamp should light, indicating that the Micro Switch 1425½EA in the thermostat A400EA is closed. The Micro Switch may be operated manually by moving the Micro Switch Actuating Arm in the thermostat with the finger, which should cause

the test lamp to go on and off if the switch is in good operating condition.

## Thermostat Adjustment

Insert Hot Metal Thermometer, AFG999A, or AFG999½A, or any other accurate type metal thermometer, near the mercury bulb in the crucible metal and allow sufficient time for the thermometer reading to reach the temperature of the metal. Then loosen Set Screw, 415E, Plate 11, and turn Stem, 414E, with Wrench, 417E (wrench is located on the inner left hand side of the case), until the indicating hand corresponds with the temperature shown by the thermometer, and then tighten the Set Screw, 415E.

## Throat Heater Test

Remove the cover of the terminal box at the back of the crucible, then remove wires B, D and C from bars 1, 2-A and 2-B. Connect the test lamp to the lighting circuit and place one test point on wire B, the other on

wire D. If the test lamp lights, the throat heating element is in good condition. No light indicates an open circuit or burned out heating element. If live test point lights when placed on wires B or D, a ground is indicated.

## Mouth Heater Test

Test the mouth heaters in the same manner as above by placing one test point on wire B and the other on wire C. If live test point lights when placed on wires B or C, a ground is indicated.

## Rheostat Test

Remove the lead wires A and I from the rheostat terminals. Connect the test lamp to the lighting circuit and place a test point on each terminal from which wires have been removed. The light should remain lighted as the knob is turned from point 0 to 12. If the light goes out at any point, it will indicate a burned out resistor or a loose connection.



Notes

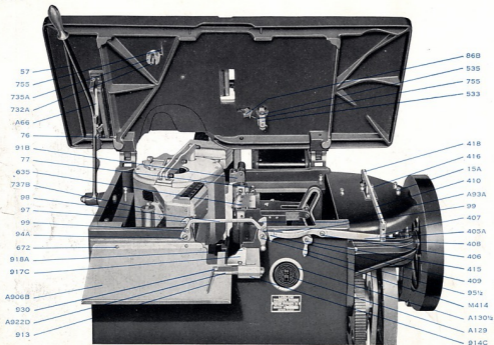

Front View of Machine—With Table Top Raised and Delivery Slide Removed

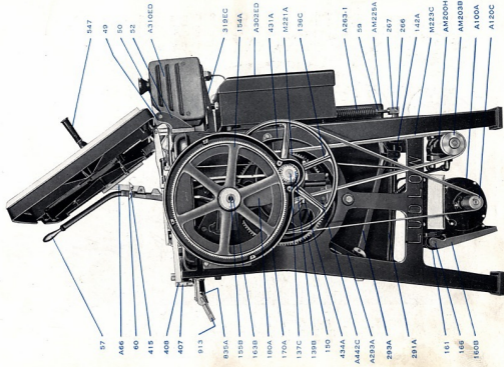

Right End View of Machine

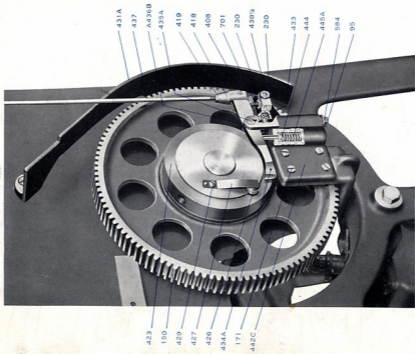

Clutch Mechanism

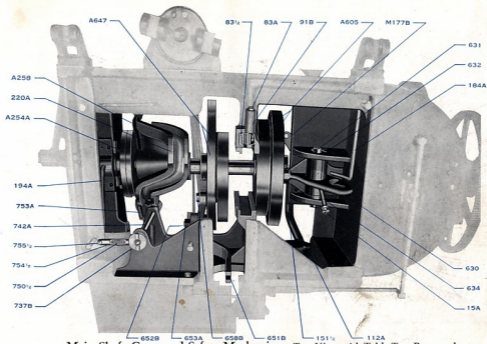

Main Shaft, Cams and Safety Mechanism—Top View with Table Top Removed

PLATE 5

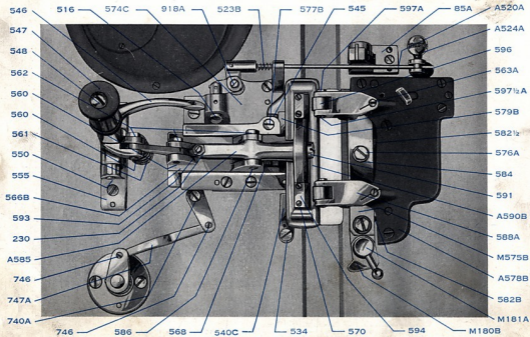

Table Top Parts

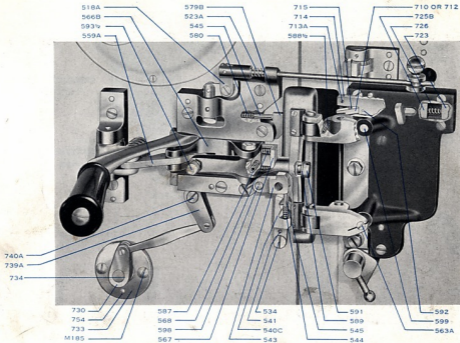

Table Top Parts—Cross-sections where small springs are located

PLATE 7



587



563A



588A



578 1/2



A578B



581



582 1/2



597A



597 1/2 A



596



556



582B



A585



A590B



588 1/2



570



430



589



591



594

Locking Down Parts



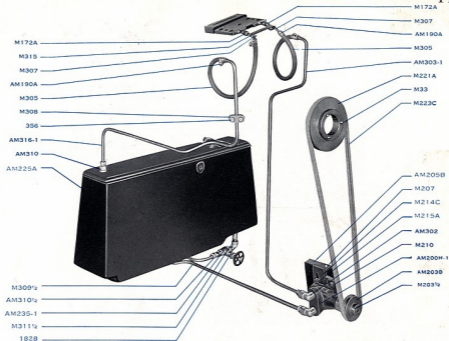

Mold Cooling System

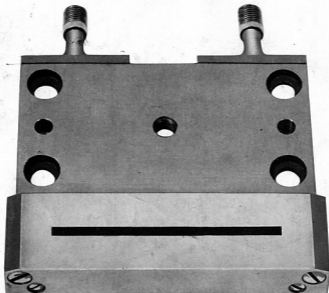

MOLD SCREW  
619

Mold—Double Water-cooled

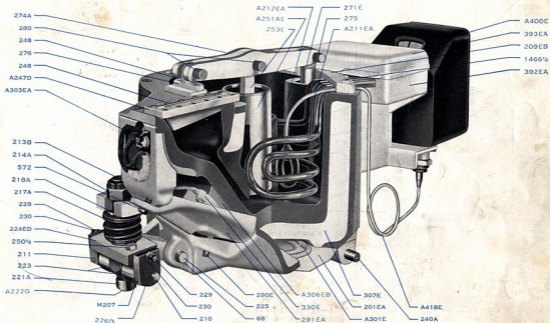

Electric Crucible Cross-Section

PLATE II

402 E  
C-402 E

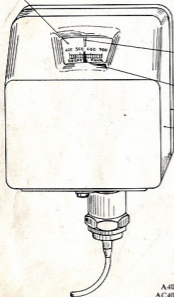

FRONT VIEW

428 E

TEMPERATURE  
INDICATING HAND  
416 E

413 E

WRENCH SYM. \*417 E  
HELD TO SIDE BY CLIP

416 E

427 E

426 E

415 E

MERCURY ELEMENT  
FLANGE - SYM. \* 421 - E

412 E

A400EA - Fahrenheit Scale  
AC400EA - Centigrade and  
Fahrenheit Combination  
Scale

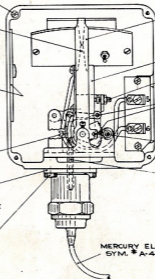

413 E

A1425 1/2 EA

416 1/2 E

414 1/2 E

411 E

414 E

MERCURY ELEMENT  
SYM. \* A-416 - E

REAR VIEW  
WITH COVER REMOVED

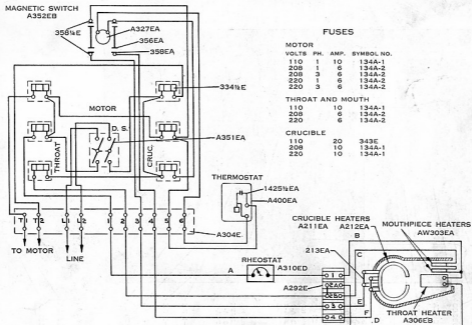

Electric Crucible Heating and Control Parts with Wiring Diagram

When ordering electrical parts always give the voltage and whether current is alternating or direct. For alternating current also give cycles.

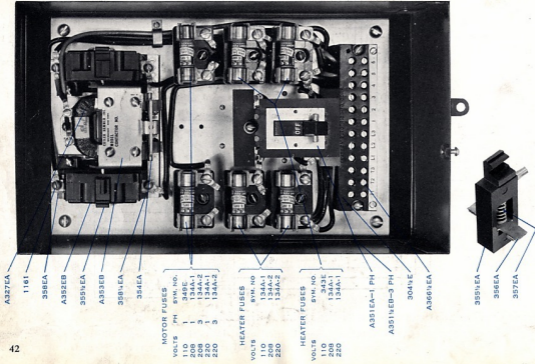

Electric Crucible Control Panel

MOTOR FUSES

VOLTS	PH	SYM. NO.
110	1	349E
208	1	134A-1
208	3	134A-2
220	1	134A-1
220	3	134A-2

HEATER FUSES

VOLTS	SYM. NO.
110	134A-1
208	134A-2
220	134A-2

HEATER FUSES

VOLTS	SYM. NO.
110	343E
208	134A-1
220	134A-1

A351EA-1 PH

A351 1/2 EB-3 PH

304 1/2 E

A366 1/2 EA

355 1/2 EA

356EA

357EA

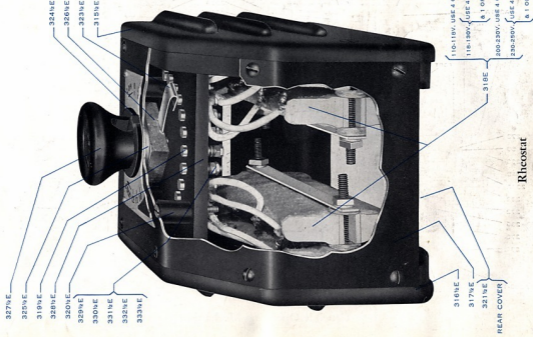

# PLATE 15

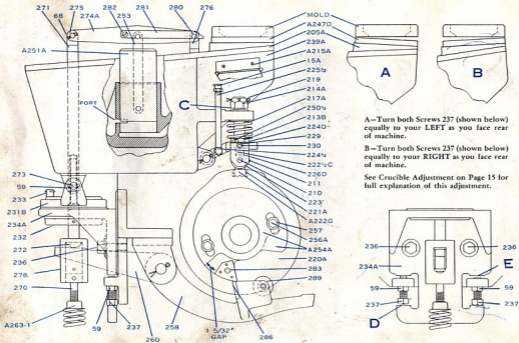

A—Turn both Screws 237 (shown below) equally to your **LEFT** as you face rear of machine.

B—Turn both Screws 237 (shown below) equally to your **RIGHT** as you face rear of machine.

See Crucible Adjustment on Page 15 for full explanation of this adjustment.

Crucible Operating Mechanism



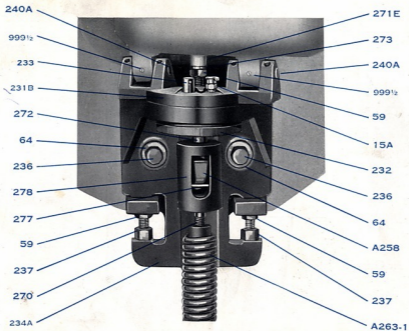

Crucible Swivel and Crucible Adjusting Parts



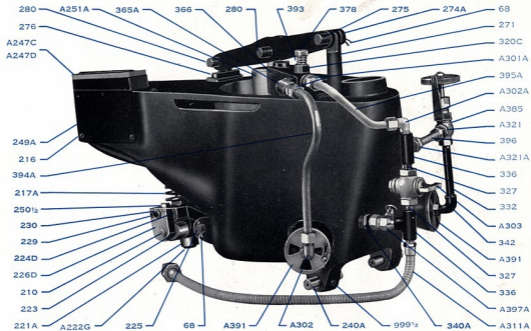

Gas Crucible

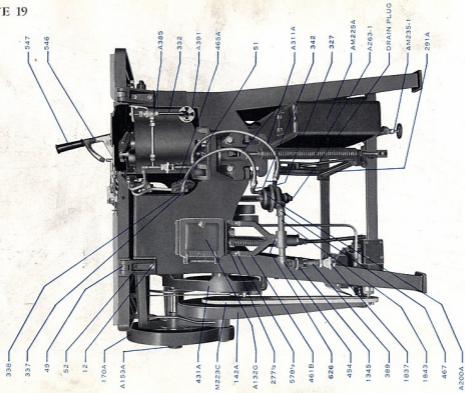

Gas Machine and Connections  
(Rear View)

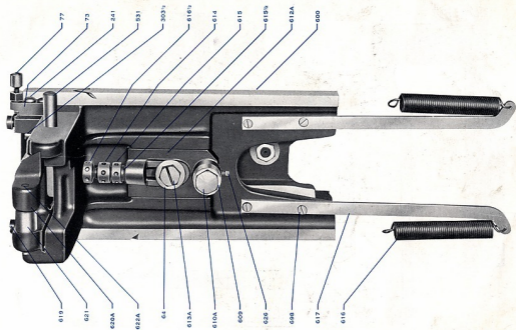

Main Slide

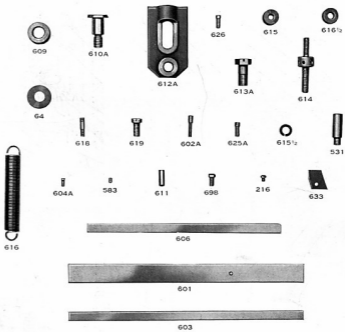
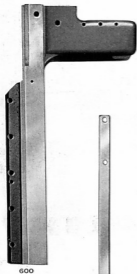

Main Slide Parts

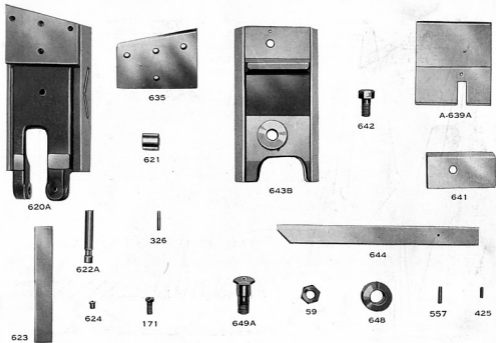

Ejector and Bottom Trim Slide Parts

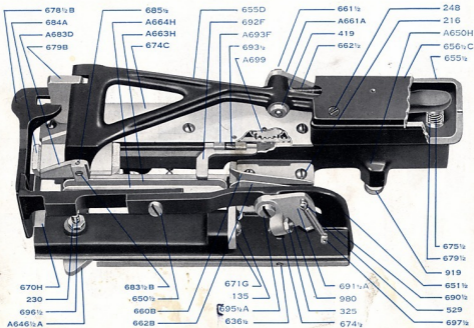

Delivery Slide—Top View



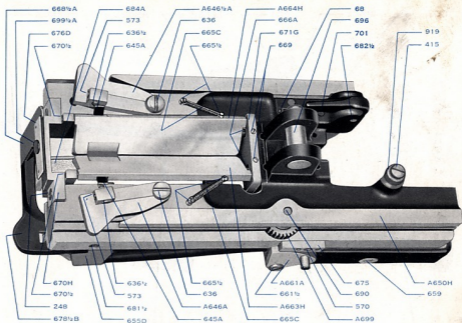

Delivery Slide—Bottom View

PLATE 25

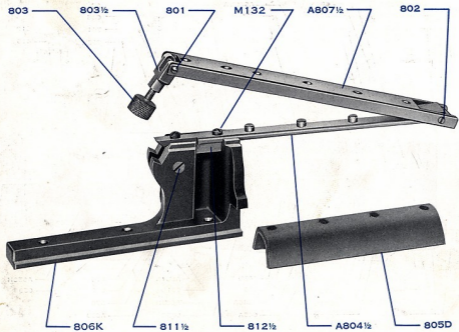

Mouthpiece Wiper



A504



A992 1/4 A



A992A



A957

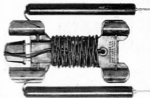

A932A



943



A939 1/2 B



A939B



946A



A965B



A970A



A945A



AFG999A (F°)  
AFG999 1/2 A (C°)



A955



958



964



M179 1/2 B



M180 1/2 A



1255



963



900



AM254

Accessories, Tools and Supplies

PLATE 27



STYLE 3



STYLE 7



STYLE 2



STYLE 8



STYLE 5



STYLE 4



STYLE 101



STYLE 102



STYLE 55



STYLE 56



STYLE 201



STYLE 57



STYLE 202



Style Chart of Screws, Nuts, Pins and Washers

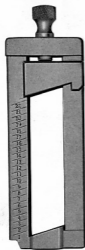

Italic Matrix Stick  
( $\frac{3}{8}$ " Italic Single-Slug)

$1\frac{1}{4}$ " Italic matrix single-slug and  
 $\frac{3}{8}$ " Italic two and three-slug  
sticks are also available.



Loose-Side Matrix Stick  
( $\frac{3}{8}$ " Roman Single-Slug)

$1\frac{1}{4}$ " and  $1\frac{1}{2}$ " Roman matrix  
sizes are also available.



6 LP Loose-Side Matrix Stick  
( $\frac{3}{8}$ " Lining Typeface Single-Slug)

Also available in two-slug length.

Available in mold lengths of 21 and  $22\frac{1}{2}$  em

Screw S-702-A  
 Nut S-703



Loose-Side Matrix Stick  
 ( $\frac{3}{8}$ " Roman Two-Slug)

Solid-Side sticks are available for  $\frac{3}{8}$ " roman matrices in three and five-slug lengths, also for  $1\frac{1}{4}$ " and  $1\frac{1}{2}$ " roman matrices in two, three and five-slug lengths.

The  $\frac{3}{8}$ " and  $1\frac{1}{4}$ " roman five-slug solid-side matrix stick may be provided with angle quads, one division quad clamp and three italic division quads for use with italic matrices.

The  $1\frac{1}{4}$ " roman two or three-slug solid-side matrix stick may be provided with angle quads, and italic division quads for use with italic matrices.

Available in mold lengths of 21 and  $22\frac{1}{2}$  em.

4-11-80

7/8" roman 22 1/2 em  
 Cast # 245.00



Self-Quadding Stick  
 (Roman Single-Slug)

Available for 3/8", 1/4", roman and italic, also Lining Typeface  
 Matrices, in mold lengths of 21 and 22 1/2 em



Self-Quadding Stick  
 (Roman Two-Slug)

Available for 3/8", roman and italic, also Lining Typeface  
 Matrices, in mold lengths of 21 and 22 1/2 em

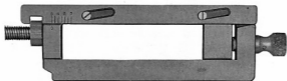

Bottom View



Top View

Adjustable Offset Matrix Stick  
(Single-Slug)

Available for  $\frac{3}{8}$ " Roman matrices, in single and two-slug sticks  
in mold lengths of 21 and 22½ cm



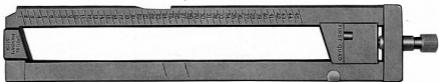

Mandate Matrix Stick  
( $\frac{3}{8}$ " Two-Slug)

Available only in two-slug sticks for  $\frac{3}{8}$ " and  $1\frac{1}{4}$ " matrices  
in mold lengths of 21 and  $22\frac{1}{2}$  cm

*7/8" 22 1/2 em  
cost \$644.50*



**7/8" Self-Centering Stick**  
(also available for Lining Typeface Matrices)

Available in mold lengths of 21 and 22 1/2 cm



SS02A

3/8" 6LP Division Quad  
for Lining Typeface  
Matrix Sticks.



SS00A

3/8" Roman Division Quad for  
Loose-Side, Solid-Side and Self-  
Quadding Sticks. 1 1/4" and the  
1 1/2" sizes are also available.



SS01A

3/8" Italic Division Quad for  
Italic, Mandate and Self-  
Quadding Sticks. 1 1/4" size is  
also available.



SS29A

3/8" Offset Division Quad for  
Adjustable Offset Matrix  
Stick.



3/8" Mandate Stick Quad Block (made of  
brass). 1 1/4" size is also available.



SS03B

3/8" Italic Division Quad Clamp for  
5-slug matrix stick. 1 1/4" size is  
also available.

Division Quads and Division Quad Clamp (Made of hardened stainless steel)

Parts shown above for mold lengths of 21 and 22 1/2 cm

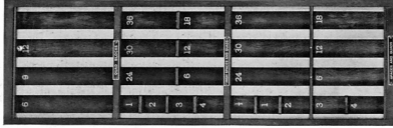

AMC120A



AMC122



AMC121A

### Space and Quad Trays and Division Quad Tray

Available for  $\frac{3}{8}$ " and  $1\frac{1}{4}$ " roman and italic, for  $1\frac{1}{8}$ " roman spaces and quads, and for division quads in all three sizes

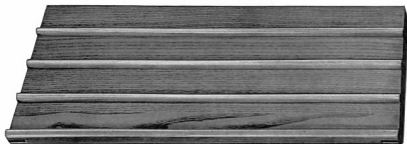

AMC124 $\frac{1}{2}$

Matrix Stick-Board for Angle-Top Cabinet

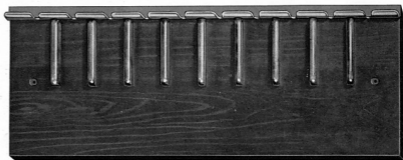

AMC124

Matrix Stick-Rack for Universal Cabinet

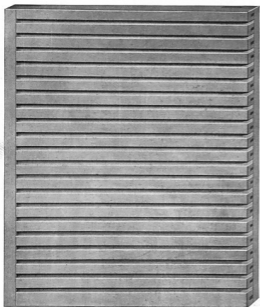

MC137

Slug Trays



B10A

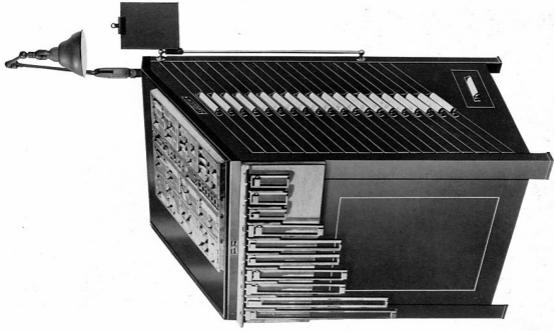

**Universal Matrix Cabinet**

Right-hand pull shown with Space and Quad Trays,  
Stick Rack, Light Fixture and Copy Holder



Angle Top Matrix Cabinet  
Left-hand pull shown with Light Fixture and Copy Holder



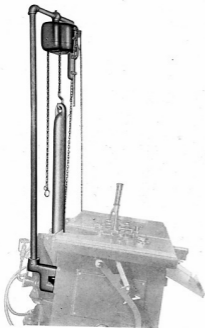

Margach

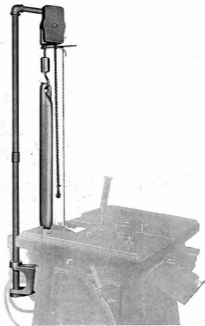

Star

Automatic Metal Feeders—Ludlow Models

1-312-792-2333  
Loblou - Chicago ILL



