

No. 844,561.

PATENTED FEB. 19, 1907.

B. M. DES JARDINS.
TYPE JUSTIFIER.

APPLICATION FILED JULY 5, 1895.

6 SHEETS—SHEET 1.

Fig. 1.

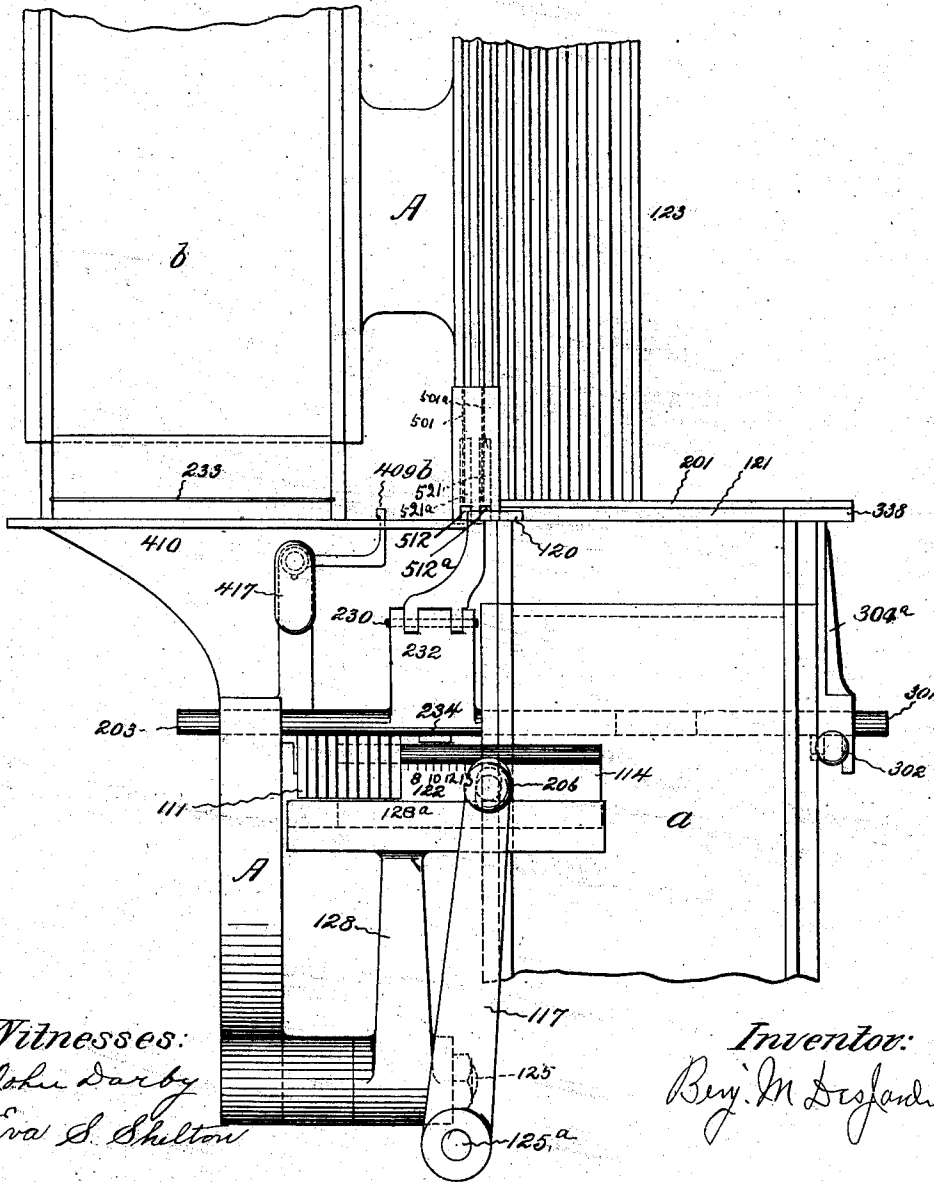

Witnesses:
John Darby
Eva S. Shelton

Inventor:
Bey. M. Desjardins

B. M. DES JARDINS.
TYPE JUSTIFIER.

APPLICATION FILED JULY 5, 1895.

6 SHEETS—SHEET 2.

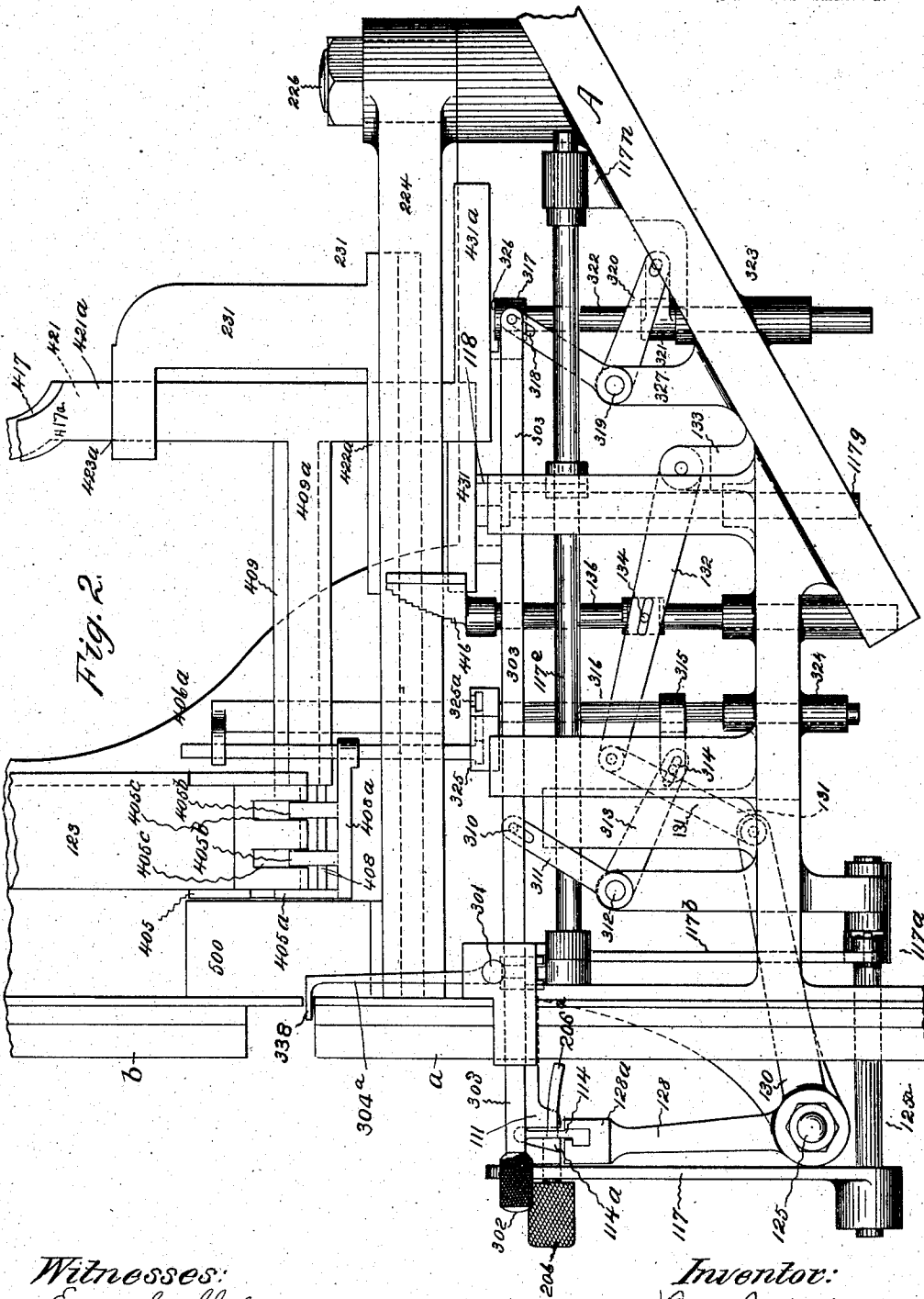

Fig. 2.

Witnesses:
Eva S. Shelton
John Darby

Inventor:
Benj. M. Desjardins

B. M. DES JARDINS.
TYPE JUSTIFIER.

APPLICATION FILED JULY 5, 1895.

6 SHEETS—SHEET 3.

Fig. 3.

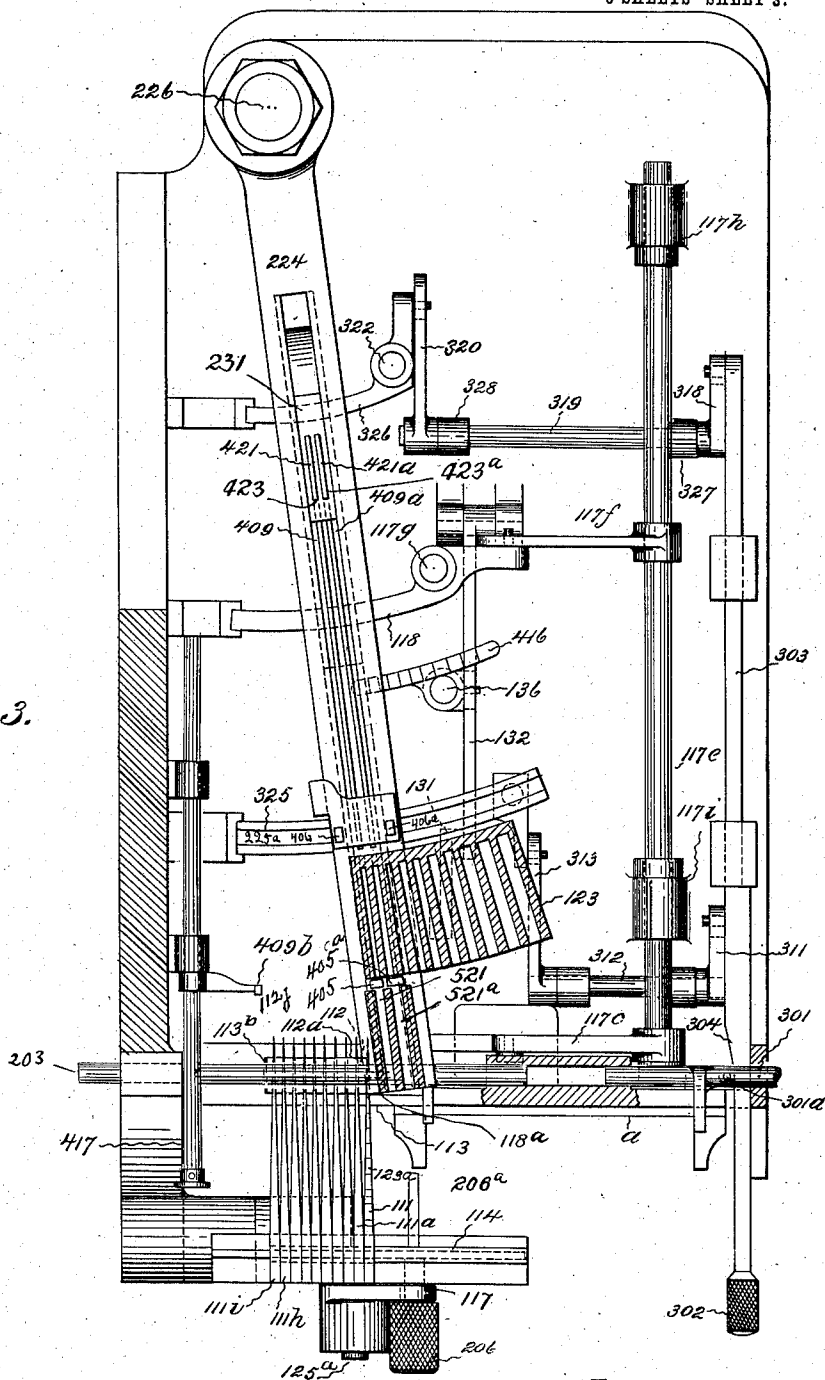

Witnesses:
 Eva S. Shelton.
 John Darby.

Inventor:
 Benj. M. Desjardins

B. M. DES JARDINS.
TYPE JUSTIFIER.
APPLICATION FILED JULY 5, 1895.

Fig. 4.

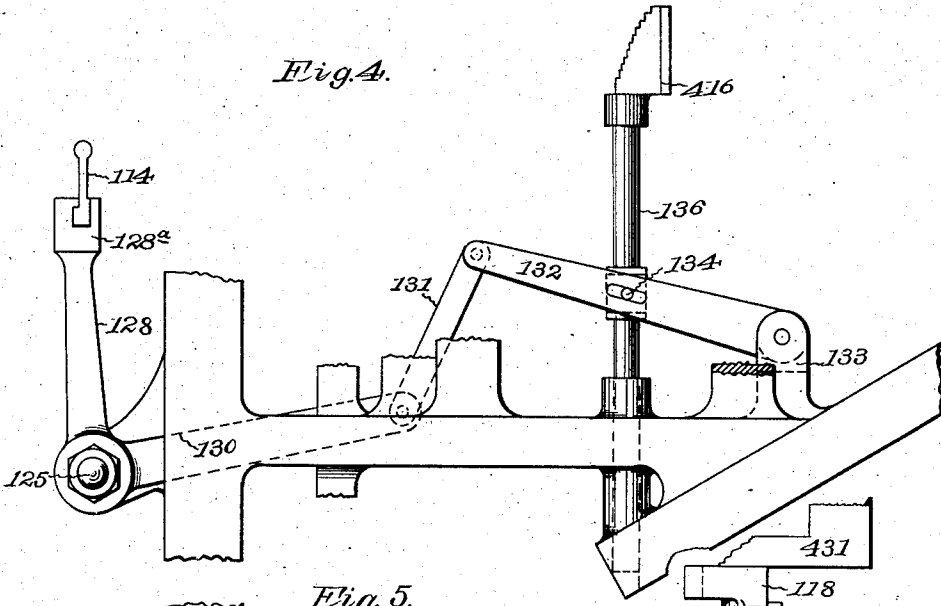

Fig. 5.

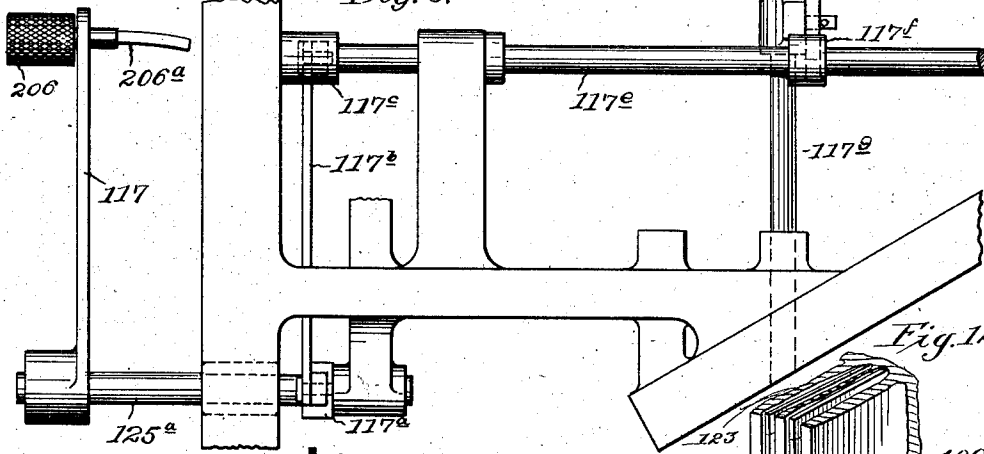

Fig. 6.

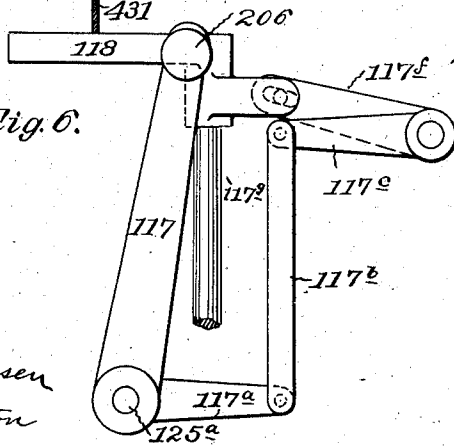
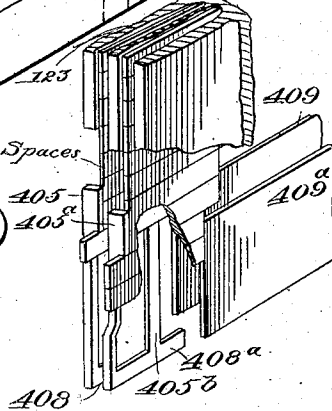

Fig. 12.



Witnesses:
Edward C. Claussen
Eva S. Shelton

Inventor:
Benj. M. Desjardins

B. M. DES JARDINS.
TYPE JUSTIFIER.

APPLICATION FILED JULY 6, 1896.

6 SHEETS—SHEET 5.

Fig. 7.

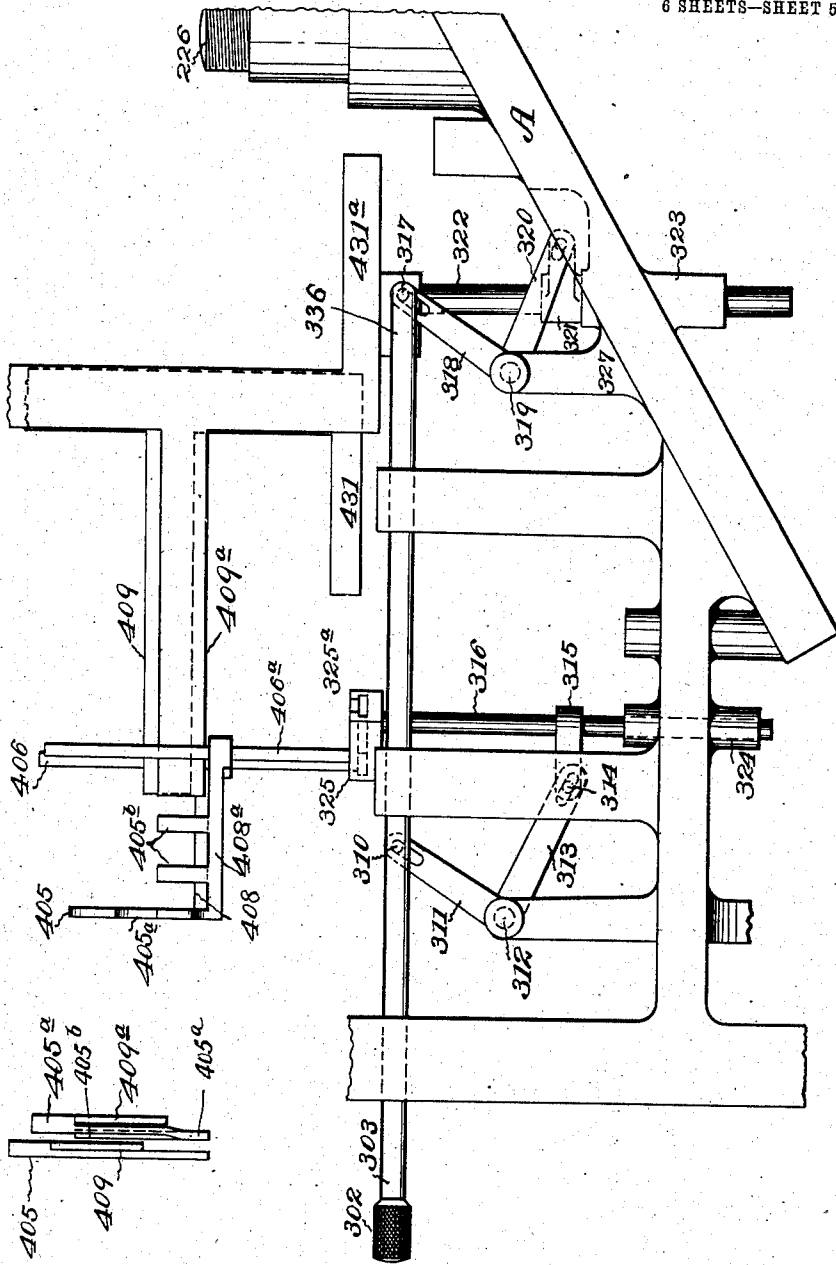
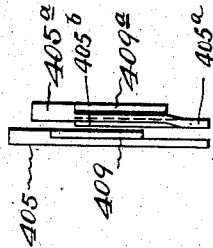

Fig. 8.



Witnesses:
Edward C. Claussen,
Cora S. Shelton.

Inventor:
Benj. M. Desjardins.

B. M. DES JARDINS.
TYPE JUSTIFIER.

APPLICATION FILED JULY 5, 1895.

6 SHEETS—SHEET 6.

Fig. 9

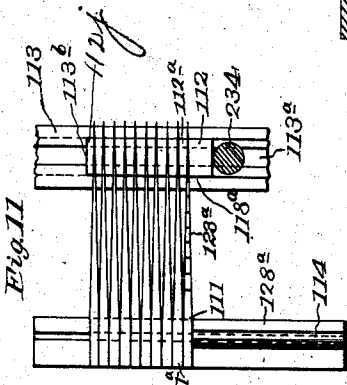
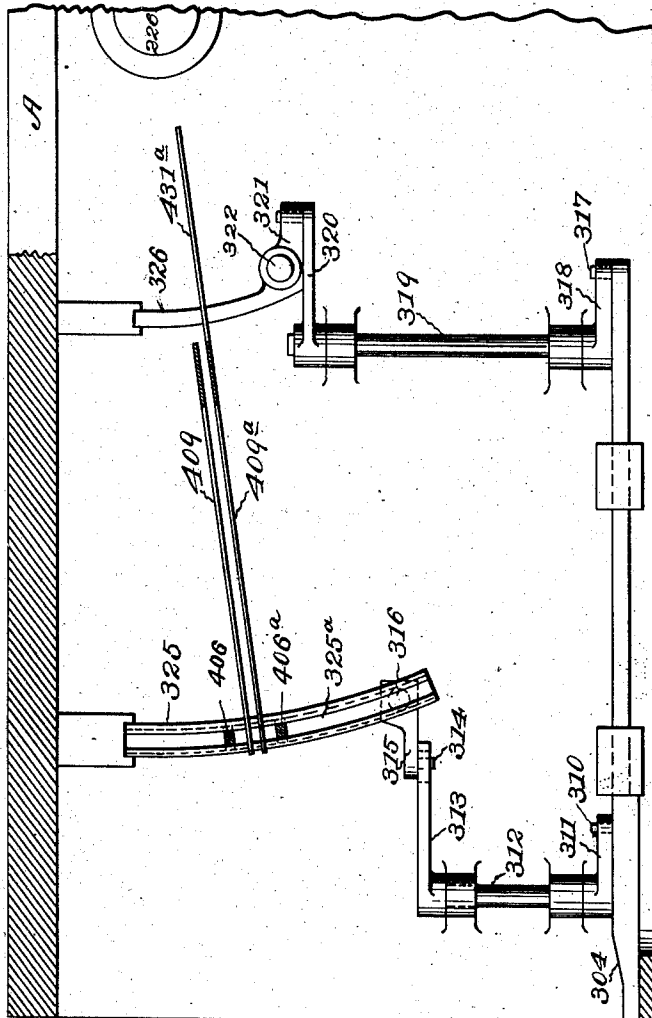

Fig. 11

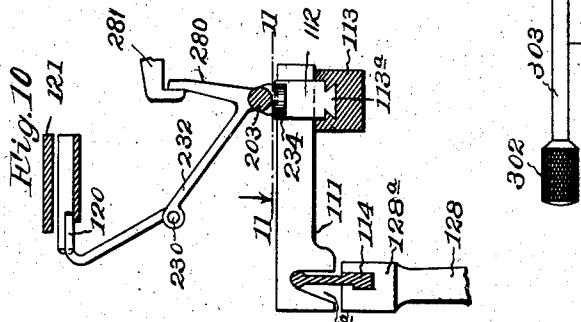

Fig. 10

Witnesses:
Edward C. Claussen,
Eva S. Shelton.

Inventor:
Benj. M. Desjardins

UNITED STATES PATENT OFFICE.

BENJAMIN M. DES JARDINS, OF HARTFORD, CONNECTICUT, ASSIGNOR, BY
MESNE ASSIGNMENTS, TO THE UNITYPE COMPANY, A CORPORATION OF
NEW JERSEY.

TYPE-JUSTIFIER.

No. 844,561.

Specification of Letters Patent.

Patented Feb. 19, 1907.

Application filed July 5, 1895. Serial No. 555,008.

To all whom it may concern:

Be it known that I, BENJAMIN M. DES JARDINS, a citizen of the United States, residing at Hartford, in the county of Hartford and State of Connecticut, have invented a new and useful Type-Justifier, of which the following is a specification.

The present invention consists in novel justifying mechanism the several elements of which are adapted to be used in justifying lines of composition in the various composing-machines, such as linotype and typesetting machines.

The specific embodiment of the invention illustrated and described is adapted to justify lines of ordinary printers' type.

The invention comprises two measuring devices, one of which is adapted to measure the shortage of a line of type and control the selection of the proper size of space or spaces necessary to justify the line. A limited number of sizes of spaces are preferably provided, the successive sizes differing from each other by a uniform amount, termed a "unit," and any line may be justified with sufficient accuracy by inserting spaces of a single size or of two sizes differing by a unit—that is, two consecutive sizes.

The particular measuring device employed to locate or select the spaces in this machine consists of a series of tapering gages, which in the preferred embodiment of the invention are constructed and operated to form wedges. In justifying a line a number of wedges corresponding to the number of "intervals" between words in the line are simultaneously advanced into a space corresponding to the shortage of the line. The number of wedges used is made to control the number of spaces selected, and the distance to which the wedges are advanced controls the size of the spaces selected.

When a limited number of sizes of spaces are used, it usually happens that the shortage of the line is not divisible without a remainder by the size of the largest space which could uniformly be inserted in the line. The shortage may therefore be considered as made up of an integral portion and a remainder. If there be a remainder, it is filled by employing as many spaces of the next larger size as there are units in the remainder. For this purpose the second measuring device mentioned above is used, this consisting of

a remainder device which mechanically measures the remainder for each line and controls the selection of the proper number of spaces of the next larger size to absorb the remainder wholly or within a fraction of a unit.

Another feature of my invention in its most complete form is that it predetermines and selects all the spaces necessary for a line before dislodging any of said spaces from the magazine, and then by a single movement it discharges the entire number of spaces into a receiver, from which they may be transferred to the line at the convenience of the operator.

The invention also consists in numerous improvements in details, all of which will be particularly described in the following specification, reference being had to the accompanying drawings, in which—

Figure 1 is a front elevation of my machine, the lower part of the frame being removed; Fig. 2, a right side elevation of said machine; Fig. 3, a sectional plan view of the same; Fig. 4, a side view of the mechanism which locates the plungers relative to the required sizes of spaces in accordance with the position of the gages; Figs. 5 and 6, respectively, side and front views of the mechanism which designates the required number of spaces and of members which become thereby adjusted to engage said required number; Fig. 7, a side view of the difference device, illustrating how the second measurement controls the required number of larger spaces and subtracts the same number from the smaller ones; Fig. 8, a front view of the column-lifting devices in a position above that shown in Fig. 7; Fig. 9, a plan view and partial section of Fig. 7; Figs. 10 and 11, detailed views of the gages and accompanying mechanism, Fig. 11 being a plan view taken on lines 11 11, Fig. 10, in the direction of the arrow; and Fig. 12 is a detail of the space-ejecting devices.

Similar letters and figures of reference designate like parts in the drawings and specification.

The frame is designated by A, the primary measuring elements or gages by 111 111^a, &c., the remainder-measuring elements by numbers between 300 and 400, the space-transferring mechanism by numbers from the next one hundred figures, and the intermediate space receiving and transferring device by the numbers between 500 and 600. The

type-galleys *a* and *b* are located in a nearly-vertical position, being slightly inclined backward. The galley *a*, which receives the loose unjustified lines of type, is located at
 5 the lower right-hand corner of the machine, and the galley *b* for justified matter, at the upper left-hand corner. In this construction the space-channels 123 are preferably arranged in the arc of a circle and in the path
 10 of the swinging arm 224.

The arm 224 is pivoted to the frame A at 226, and the principal function of said arm is to carry the space-dislodging members from channel to channel, according to the size of
 15 spaces wanted. Hence its front end is free to swing from a position at the left adjoining the right end of the galley *b* to a position at the extreme right of the space-channels 123. The arm 224 is provided with a grooved slideway
 20 extending nearly the entire length of that part of said arm that is back of the channels 123. This slideway passes clear through the arm 224 from top to bottom to receive the reciprocating plunger-carrying mechanism 231.
 25 Said arm extends in front of said channels a sufficient distance to form a support for the intermediate space-receiving device 500. The mechanism 231 has a supporting-base adapted to slide back and forth in said slide-
 30 way in the arm 224 and also an upper projection to support the slide-boxes 423 and 423^a, which receive the upper terminals of the guides 421 and 421^a. Corresponding boxes are cut through said base to receive the lower
 35 terminals of said guides, one of said boxes being indicated at 422^a in Fig. 2. The space plungers or blades 409 and 409^a are respectively provided with the T-guides 421 and 421^a, before mentioned, which slide up and
 40 down in their boxes. The guides 421 and 421^a are respectively provided at the top with the operating-handles 417 and 417^a. The guide 421 has the forward projection 431 at its lower end, and the guide 421^a has the
 45 projection 431^a, similar to said projection 431, except in the direction, which is to the rear. The arm 224 is provided with a suitable slideway, as stated, along which the mechanism 231 is adapted to be moved whatever distance
 50 is necessary to eject the spaces from the channels 123. The projections 431 and 431^a are constructed a little longer than the amount of the required motion of their connections, and consequently always rest upon
 55 their respective narrow arc-supports 118 and 326 at whatever position the sliding mechanism may be. The movement of the arm 224 behind the type-galleys *a* and *b* carries the intermediate space-receiving device 500 back
 60 and forth between the channels 123 and said galley *b*.

The elements that practically determine the size of spaces required consist of the wedges or tapered gages 111 111^a, &c., Figs.
 65 1, 3, 10, and 11. There are as many of these

gages as the largest number of spaces ever required by any one type-line, ten being provided in the machine herein shown and described. Said gages occupy a position between the rod 203 and the bar 113, resting on
 70 their edges, with the thin rear ends extending between the corresponding tapered blocks 112 112^a, &c., Fig. 11. The amount of taper in the gages 111 111^a, &c., is made to correspond with the sizes of spaces with which
 75 the machine is provided. The graduations along the scale 123^a, inscribed on the upper edge of the right-hand gage 111, indicate the various positions at which said gages correspond in size with said spaces. Said graduations register at 118^a on the corner of the right-hand
 80 block 112, and the position of the gages so registered indicates to the eye of the operator what size of spaces is required.

The blocks 112 112^a, &c., are held in place
 85 and guided by means of the V-groove 113^a in the bar 113. The right-hand block 112 is arranged to come into contact with the projection 234 of the members which carry the
 90 gage-block 120. The front end of each gage 111 111^a, &c., is provided underneath with the notch 114^a. The plate 114 is arranged to slide back and forth in its guideway in the cross-piece 128^a of the arm 128 through the
 95 notches 114^a to engage as many of said gages as are necessary to correspond with the number of places for spaces in the line being measured.

As before intimated, the taper in the blocks 112 112^a, &c., is similar to that in the gages
 100 111 111^a, &c., and said blocks are loosely inserted in the groove 113^a. The bar 113 is provided with the shoulder 113^b at the left end of the groove 113^a, said shoulder acting as a stop for the left-hand inactive block 112^b
 105 of the series 112 112^a, &c., which is between the left-hand gage and the shoulder; but said groove is open and clear to the right of said shoulders to permit of the displacement in that direction of said blocks whenever any of
 110 said gages are thrust backward between them. The backward movement of the gages 111, &c., produces a displacement to the right of as many of the blocks 112, &c., as lie on that
 115 side of the actuated gages, causing said blocks to move the sliding guide-rod 203 through the medium of the downwardly-extending projection 234. The rod 203 is adapted to slide longitudinally in its bearings in the
 120 frame A and has the upwardly-extending projection 232, to which is hinged at 230 the supporting portion of the gage-block 120, the latter capable of being turned backward or forward on the hinge 230 for the purpose of
 125 bringing it either into or out of the line-channel 121. The block 120 is adapted to be moved against the end of the type-line in the channel 121 while the latter is being measured and then to be turned forward out of the path of said line during the justification
 130

of the same. To prevent the rod 203 from rocking in its bearings, it is provided with an arm 280, which engages a guide 281, as shown in Fig. 10.

5 The appropriation or engagement of the requisite number of gages 111, &c., is done by means of the longitudinally-movable engaging plate 114. The swinging arm 128 is attached to the frame A by the stud 125, Fig. 10 4, and has the T or cross piece 128^a at the upper end. The cross-piece 128^a has a grooved guideway cut in its upper edge, in which the plate 114 is reciprocated. The plate 114 is provided with the scale 122, hav- 15 ing graduations which register the number of the gages 111, &c., and is adapted to indicate to the eye how many of said gages are engaged by said plate. The arm 117 is rigidly fastened to the rock-shaft 125^a and has 20 the operating-handle 206, provided with the rear projection 206^a, which latter passes through a suitable opening in the plate 114. The projection 206^a extends backward a distance equal to the length of travel of the 25 plate 114, so that the latter is always engaged by the former, regardless of position. The swinging motion of the arm 117 on the shaft 125^a has to do with the counting of the places for spaces between the words in the 30 line. The amount of sweep which the arm 117 makes to the left corresponds with the number of spaces required, and its position is indicated by the graduation on the scale 122 that registers with the edge of the gage 111. 35 In this form of justifier it is necessary to apply to the machine, at certain points adapted to receive it, an equivalent of the full number of spaces which will justify the line in such a manner that the machine shall be influenced 40 thereby and operate to select such number of spaces. This is done as follows: The rock-shaft 125^a, through the medium of the arm 117^a, the connecting-rod 117^b, and the arms 117^c and 117^f on the rock-shaft 117^e, operates the longitudinally-movable post 117^g, 45 which carries the arc-support 118. The arms 117^c and 117^f are rigidly attached to the rock-shaft 117^e, operating in the frame-bearings 117^a and 117ⁱ. The lengths of the arms 50 117^a, 117^c, and 117^f, just described with reference to each other and the lateral movement of the arm 117, are such that the support 118 is raised a distance equal to the space occupied by the same number of 55 spaces that is registered by the movement of the plate 114 to the left against the outer edge of the gage 111. Consequently whatever number of spaces is registered thereby must be engaged from any one of the chan- 60 ne's 123 by the blade 409, said blade being raised to a sufficient height for engaging said same number of spaces. The spaces are placed edgewise in the channe's 123, so that the same number repeated will always con- 65 stitute piles of the same height, regardless of

their thicknesses. It is also necessary for the longitudinal movement of the gages 111 111^a, &c., to bring about such a displacement and arrangement of parts as to intercept and locate the arm 224 opposite the particular channe's 123 that contain the re- 70 quired space sizes. This location must correspond to the positions of the gages 111, &c., as they register between the blocks 112, &c., and wedge the latter to the right until the 75 block 120 is thrust against the type-line. The arm 128 is provided with the bell-crank-arm extension 130, the rear end of which is connected with the lever-arm 132 by means of the bar 131. The arm 132 is pivoted to 80 the projection 133 from the frame A and has an approximately central slot to receive the pin 134. The pin 134 extends from the longitudinally-movable post 136, having its slide-bearing in the frame A. The post 136 85 has the arc-like plate 416, Figs. 3 and 4 fastened to its upper end, and said plate is provided with a series of steps or stops adapted to intercept the arm 224, each of said steps being so constructed and proportioned as to 90 stop said arm with the plunger-blades 409 and 409^a opposite two of the channe's 123, different steps representing different pairs of said channe's. The left-hand channel 123 of the two above alluded to is the one containing 95 the spaces that correspond with the particular graduation of the scale 123^a which alines with the index 118^a—that is, when the tapered gages are pushed backward until they register on the first of said graduations the 100 arm 224 in its movement to the right is intercepted by the first of the steps on the plate 416, leaving the plungers in line with the first and second of the channe's 123. When 105 said gages register on the second of said graduations, said arm is intercepted by the second of said steps, leaving said plungers in line with the second and third of said channe's, and so on. In other words, the amount of 110 dimension in the gages 111, &c., when intercepted between the tapering blocks 112, &c., in line with the corner-index 118^a, determines the distance the post 136 must be raised to intercept the arm 224 at the position 115 required to bring the plunger 409 opposite the channel 123 containing the spaces of a dimension equal to that of the particular part of said gage referred to.

In practice it often happens that when the gages 111, &c., are thrust between the blocks 120 112, &c., none of the graduations of the scale 123^a register with the index 118^a, the last of said graduations to aline with said index having passed beyond, leaving the gage dimensions between said blocks longer than 125 the largest available size of spaces which the line can receive and smaller than the next succeeding larger size. In the event of the failure of the registering elements to aline, as noted above, the operator withdraws the gages 111, 130

&c., until the last graduation on the scale 123^a to pass by the index 118^a alines therewith, and this withdrawal produces a slight looseness in the line-engaging members and in the line itself. The looseness just referred to is taken up and mechanically utilized by the members designated by the numerals between 300 and 400, of which the mechanism termed the "remainder device" is composed. The successive sizes of spaces employed in this justifier differ from each other by the same amount, termed a "unit." After the machine has ascertained the largest size of spaces capable of being introduced into a type-line without making it too long the measuring instrument of the remainder device is employed to ascertain how many units are necessary to accurately lengthen out said line to within one of said units. When the number of said units has been ascertained by means of my improvement, the same number of the next larger size of spaces than that selected are to be employed—that is, instead of adding the remainder in single units I use spaces of the next succeeding size, which are a unit thicker.

The longitudinally-movable rod 303, located at the right of the machine, is reciprocated by means of the knurled handle 302. The rod 303 is provided with the tapered gage 304, and the amount of taper in said gage is equivalent to the full amount of taper in any one of the gages 111 111^a, &c.—that is, the measuring-points of both gages corresponding to the position of the graduations on the scale 123^a are the same, notwithstanding the fact that said points may be closer together in said gage 304 than they are in said gage 111, &c. The increase of said inclines in both cases alluded to in the previous sentence corresponds to the difference existing between the sizes of neighboring spaces, the gages 111, &c., determining the full amount of the shortage in successive dimensions correlative with the sizes of spaces provided by the machine, while the gage 304 gages the remainder shown by the decrease of said gages 111, &c., when returned to the next graduation, registering the result in terms or dimensions representing the difference between said neighboring sizes and designating the number of the next larger size required to satisfy said remainder. The secondary gaging-rod 301 slides right and left in its bearings in the frame A and is provided with the roller 301^a, against which the gage 304 is adapted to wedge when the rod 303 is pulled outward. The rod 301 is also provided with the arm 304^a, at the upper end of which is the gage-block 338, designed to gage the type-line from its right-hand end, thereby traversing the looseness therein referred to above.

The rod 303 is connected by the pin 310 to the slotted arm 311, rigid with the rock-shaft

312, which has its bearings extending upward from the frames A. The vertical post 316 is provided with the tight collar 315, having the pin 314 to engage the slotted arm 313, said arm also being rigid with the rock-shaft 312, and said post is operated by means of this bell-crank-lever mechanism when the rod 303 is actuated. The post 316 slides up and down in a frame-bearing and is provided at its upper end with the arc-guide 325, having the T-groove 325^a to engage the base of the vertically-sliding bar 406^a, the functions of which will be described further on. The rod 303 is also connected by the pin 317 to the slotted arm 318, rigid with the rock-shaft 319, which has its bearings extending upward from the frame A. The vertical post 322 is provided with the tight collar 321, having a pin to engage the slotted arm 320, said arm also being rigid with the rock-shaft 319, and said post is operated by means of this bell-crank mechanism when the rod 303 is actuated in a similar manner to the post 316. The post 322 slides up and down in a frame-bearing and is provided at its upper end with the arc-support 326. As already stated, the function of the remainder device is to determine and mechanically cause the machine to appropriate the required number of larger spaces which are to be added to the smaller ones.

The plunger-blade 409^a is so mounted with reference to the plunger-blade 409 as to always engage the size of spaces next larger than that opposite which the latter is located. As already described, the members which control the blade 409 raise it high enough to engage the whole number of spaces required in the line. Whatever number of larger spaces are necessary to justify said line must be subtracted from the number adjacent to the blade 409, and the blade 409^a, which is located opposite said larger spaces, must also be raised to a height sufficient to engage the subtracted number.

The arc-guide 326, which is adjusted by the difference device, as already pointed out, operates as follows: The bottom under the channel 123, that contains the smaller spaces behind which the plunger 409 is located in the manner already explained, is raised to a level with the top of the plunger 409^a, at one side of the path of said plunger 409. This false or movable bottom consists of the projections 405^b and the horizontal bar 408^a, from which said projections extend upward. The bar 408^a is connected to the vertical bar 406^a. The lower ends of the space-channels 123 are cut away to form the openings 405^c for the reception of the false-bottom projections 405^b. The location of said false bottom relative to the blade 409^a is such that the tops of the projections 405^b are always on a level with the upper edge of said blade. Hence the column of spaces opposite the

blade 409 is elevated by said projections sufficiently to only permit of the engagement by said blade of the spaces which lie in a plane above said blade 409^a. The guard 405^a is
 5 connected to said bar 408^a and has an offset therein to enable its upper projection to extend across the channel 123 that happens to be in front of the plunger 409^a for the purpose of cutting off whatever spaces lie above
 10 the same. It will now be seen that the guard 405^a serves as a stop in front of whichever channel 123 it is located opposite and prevents more than the required number of spaces from being displaced by the plunger
 15 409^a. The bar 406^a and the corresponding bar 406 are mounted and slide up and down in suitable boxes which are rigid with the arm 224, and the base of the latter bar extends into the groove 325^a, where it is engaged
 20 by the guide 325 in a manner similar to the base of the other bar. Mounted to slide vertically on the bar 406 is a horizontal bar 408, which carries a guard 405 to protect the spaces which lie above the plunger
 25 409, and said horizontal bar 408 has a recess to receive said plunger by which it is adjusted vertically. The rearwardly-extending projection 431^a, which is long enough to always rest upon the arc-support 326, provides a bearing for the blade 409^a at whatever
 30 position it may be during the longitudinal movement thereof in the operation of dislodging spaces from any one of the channels 123. These plunger-blades are adjusted so that the plunger 409 engages the space or
 35 spaces back of their left edges as the false-bottom projections 405^b, which are adjusted to one side of said plunger, raise and support said spaces by coming up under the
 40 right edge of the column, lifting and maintaining it above the regular bottom of the channels 123. When there is no remainder, both the plunger 409^a and the projections 405^b lie below the regular bottom of the
 45 channels 123, and said plunger is not then in position to operate upon any of the spaces. In the event of there being no remainder, as signified above, the plunger 409 operates on all of the spaces in the channel 123 opposite
 50 thereto, as only spaces of one size are needed. The plunger-carrying mechanism 231 is adapted to slide forward and back in the arm 224 from a position at the rear of the machine near the pivot 226 forward a sufficient
 55 distance to cause the blades 409 and 409^a to thrust their respective space-piles out of the channels 123 and into the intermediate receiving device 500. In addition to their longitudinal movement the blades 409 and
 60 409^a have the vertical and lateral adjustments previously described. Their up-and-down motion is controlled by the position of the arc-support 326 for the plunger 409^a, and the arc-support 118 for the plunger 409.
 65 The plungers 409 and 409^a are reciprocated

longitudinally by the operator, who grasps the handles 417 and 417^a.

The intermediate receiving device 500 is provided with the channels 521 and 521^a for
 70 simultaneously receiving two piles of spaces. The right-hand pile of spaces is always moved forward in line with the bottom of the corresponding channel 521; but the channel
 75 521^a is liable to receive its spaces at a considerable distance above the bottom and is therefore provided with the friction-spring 501, adapted to press said spaces against the opposite wall and hold them suspended until they are released therefrom and thrust
 80 downward upon the bottom of said channel by the operator. The right intermediate channel 521 is also provided with the spring 501^a, similar to spring 501, to retain the thin spaces in place. When the spaces are ready
 85 to be transferred from the device 500 into the line-channel 121 between the words, the arm 224 is swung until either the channel 521 or 521^a is brought over the space-plunger 409^b. The engaging projection of the plunger 409^b is adapted to pass through a bottom slot in
 90 either of the channels 521 and 521^a and engages the lowest of the spaces which are pressed close to the left channel-wall, thrusting it out through the opening 512 and 512^a onto the receiving-platform 410. The plunger
 95 409^b is mounted on the rod 417, that slides in lugs projecting from the frame A, said rod being suitably keyed in its bearings to prevent the same from turning, and is operated by hand as the spaces are needed. The plat-
 100 form 410, upon which the spaces are deposited by the plunger 409^b, extends in front of the channels 521 and 521^a when operatively situated relative to said plunger and on the same plane at which position said spaces are caught
 105 by the movement of the words to the left in their passage from the upper end of the galley *a* to the lower end of the galley *b*, as more fully described in connection with the complete statement of the operation of the machine.
 110 The operation of my machine is described as follows: A column of loose unjustified type is placed in the galley *a* and held up against gravity by means of a strong spring-
 115 tensioned block. The operator pushes the column upward with his right hand until the top line abuts the wall 201, said line being then fully within the channel 121. First counting the places for spaces between the words, the operator next by means of the
 120 handle 206 pushes the plate 114 to the left until as many of the gages 111, &c., are engaged as there are places for spaces in the line. In order to readily determine what amount of travel is needed for the plate 114,
 125 the operator watches the scale 122, which registers the number of the gages 111, &c. With his left hand he turns the gage-block 120 rearward into and across the line-channel 121 and then with his right hand still on the
 130

handle 206 thrusts the plate 114 backward with his left hand and forces said gages to the rear, causing them to separate and wedge between the blocks 112, &c., while the rearward movement of the plate 114 at the same time gives a rotary motion to the arm 128. The separation of the blocks 112, &c., as the gages 111, &c., are wedged between them causes the horizontal rod 203 to be thrust longitudinally to the right until checked by the contact of the block 120 with the end of the type-line. With his eye on the scale 123^a on the right-hand gage 111 the operator pulls the plate 114 toward him if said scale is intercepted between two of its graduations until the proper graduation is brought into alignment with the index 118^a on the block 112. This return of the gages 111, &c., produces the slight looseness between the block 120 and the type line hereinbefore described. The arm 224 is next swung to the right until its further movement is prevented by engagement with the stepped plate 416. With his hand on the handle 302 the operator then draws the rod 303 toward him until its tapered gage 304 comes in contact with the roller 301^a and the wedging action has thrust the type-line tight against the block 120 through the medium of the gage-block 338, which is against the end of said line opposite said block 120, thereby taking up the looseness between the block 120 and the type-line.

The few simple motions enumerated above by means of their levers and other connections have brought about the following-described adjustments of parts: The movement to the left of the handle 206 as the plate 114 was brought into engagement with the required number of gages 111, &c., rotated the shaft 125^a, which in turn raised the arc-support 118 to fix the height of the plunger 409 at whatever point is necessary to engage the full number of requisite spaces. The thrusting of the measuring-gages to the rear for the purpose of securing the primary measurement of the line operates the stepped plate 416 through the medium of the intervening connections. The swinging of the arm until intercepted by the stepped plate 416 located the plunger 409 in line with the space-channel 123, containing the spaces that correspond with the graduation of the scale 123^a, which aligns with the index 118^a, and the plunger 409^a in line with the adjoining channel containing the next larger size spaces, and the outward pull on the handle 302, to which are connected the members comprising the difference-measuring elements located the height of the arc-guide 325 and of the false-bottom projection 405^b to raise and support the column containing the smaller of the two sizes of spaces. The column of said smaller size has been elevated so that the plunger 409 can engage only the number of spaces which lie between the top of said

plunger and the plane of the top of the plunger 409^a. The displacement of the difference device also fixes the location of the arc-support 326, upon which the plunger 409^a rests at a height equivalent to that of the pile of the larger size of spaces required. The space-dislodging mechanism is now located back of the requisite sizes of spaces, and the operator takes hold of the handles 417 and 417^a and draws the plunger-blades 409 and 409^a forward to expel whatever spaces are in front of said blades from their channels 123 into the intermediate receiving-channels 521 and 521^a. Then after restoring the plunger-locating mechanism to normal position by pressing downward on the handles 417 and 417^a the plungers 409 and 409^a are forced downward until even with the real bottom of the channels 123 to allow the space-columns therein to settle down to their normal positions of rest, and said plungers are moved backward until clear of said channels without disturbing the spaces further. By swinging the arm 224 to the left, the channels 521 and 521^a are brought in line with the plunger 409^b, which ejects the spaces from said channels onto the platform 410 as the operator manipulates said plunger forward and back, holding first one of said channels and then the other in line with the same as said spaces are needed. The spaces are deposited on the platform 410 in the path of the words as they are moved to the left. Said words are separated from the line and moved along the channel 121 to the galley *b* by means of a sharp rule in the hand of the operator. When the line is justified, the rule 233 is withdrawn from the column in the galley *b* and inserted beneath said line, which is then raised with said column into said galley and out of the path of the succeeding line.

While the mechanism shown as embodying the invention is adapted for handling ordinary type and the invention is especially intended for such use, it will be understood that the invention is not limited to machines for justifying such ordinary type, but may be applied also in justifying type, matrices, or the like of any suitable material and that the word "type" is used in this specification and the claims in this broad sense. It will be understood also that the devices for measuring the line shortage and dividing such shortage by the number of intervals in the line to determine the proper width of justifying-spaces are applicable not only in machines for justifying composed lines of type or matrices, but in line-justifying mechanism of other classes, and the term "justifying mechanism" herein is used in this broad sense to include all classes of typographic work in which lines are to be justified for printing or the production of printing-surfaces. These calculating devices in the machine illustrated and described herein are

combined with a space-magazine and devices for supplying and inserting ready-made spaces; but it will be understood that the justifying-spaces, the size of which is determined by these calculating devices, may be provided otherwise than by using ready-made spaces, suitable space forming or supplying and inserting devices being combined with the calculating devices for this purpose.

What I claim as my invention, and desire to secure by Letters Patent, is—

1. In a justifying mechanism, a series of gages, means for selecting certain of said gages equal in number to the intervals in the line under justification, means for advancing said selected gages into a limiting space proportional to the shortage of the line, and means controlled by the movement of the gages for predetermining justifying-spaces for the line prior to the introduction of any of such spaces into the line.

2. In justifying mechanism, a series of gages, means for selecting certain of said gages equal in number to the intervals in the line under justification, means for advancing said selected gages into a limiting space proportional to the shortage of the line, and means controlled by the movement of the gages for predetermining and selecting justifying-spaces for the line prior to the introduction of any of such spaces into the line.

3. In justifying mechanism, a series of justifying-gages, means for selecting a number of said gages equal to the number of intervals in the line under justification, means for advancing said gages into a limiting space proportional to the integral part of the quotient of the shortage of the line divided by the number of intervals, means controlled by said movement of the gages to predetermine and select two sizes of spaces for the justification of the line, a gage for the remainder of the shortage, and means controlled by said gage for selecting the proper proportion of each size of said spaces.

4. In a justifying mechanism, the combination of two parts external to a line of type and adapted to be separated an amount proportionate to the shortage of the line, a series of wedges, means for selecting a group of the wedges equal in number to the intervals in the line, means for advancing said group of wedges between the parts to measure the shortage of the line, and means for utilizing the movement of the wedges to determine justifying-spaces for the line.

5. In a type-justifying machine, the combination with a magazine for justifying-spaces, a plunger for ejecting spaces from the magazine, means for measuring the shortage of an unjustified line comprising a series of wedges, and means for advancing selected wedges into a space external to the line and proportional to the shortage, said space-plunger being automatically located with

reference to the magazine in accordance with the amount of advancement of the wedges.

6. In a type-justifying machine, the combination of a space-magazine adapted to contain a limited number of sizes of spaces, two space-ejecting plungers, and means controlled by the shortage of a line and the number of word-spaces for locating said space-plungers opposite the magazine-channels containing the proper justifying-spaces for the line.

7. In a type-justifying machine, the combination of a space-magazine having channels for a limited number of spaces, two space-ejecting plungers capable of movement laterally and longitudinally of the space-channels, and means governed by the shortage of a line and the number of its intervals for locating said space-plungers in position to eject by a single movement the proper number and sizes of justifying-spaces for the line.

8. The combination with a space-magazine having a plurality of channels, of two space-plungers adapted to eject spaces from adjoining channels of the magazine, means for moving said plungers relatively to the magazine to bring them opposite different channels, and means for imparting an independent movement to the plungers lengthwise of the channels, whereby all of the justifying-spaces for a line may be ejected by a single movement of the plungers.

9. The combination of a magazine having a series of space-channels, an arm movable transversely of said channels and provided with two space-ejecting plungers, means for adjusting said plungers independently lengthwise of the space-channels, and means for driving the plungers simultaneously whereby all of the justifying-spaces for a line may be ejected by a single forward movement of the plungers.

10. In a justifying mechanism, a series of gages, each representing the various sizes of spaces with which the machine is provided, means for selecting a group of gages equal in number to the intervals of a line, means for advancing said gages into a space proportionate to the shortage of a line to ascertain the largest space which will enter uniformly into the intervals of the line, means for measuring the remainder of the shortage which would have to be filled if said maximum spaces were inserted uniformly, said means being adapted for predetermining the justifying-spaces for a line prior to the introduction of any of such spaces into the line.

11. In a mechanism for justifying lines of type with spaces of two consecutive sizes, a space-magazine, a pair of ejecting-plungers arranged to eject spaces simultaneously from two channels of the magazine, a series of wedges, means for selecting and driving a group of said wedges corresponding in number to the intervals of the line to be justified,

- means for locating the space-plungers relatively to the space-channels in accordance with the forward movement of the wedges, a tapered gage arranged to measure the remainder which would exist if a single size of spaces were used in the line, and means connected with said gage for adjusting one of said plungers to select a sufficient number of larger spaces to justify the line.
12. The means for determining the required size of spaces to use in justifying type, consisting of a plurality of tapering gages and blocks, mechanism to limit the lateral movement of the latter in accordance with the shortage of a type-line when said gages are thrust between said blocks, a space-plunger, a stepped plate adapted to intercept the lateral movement of said plunger, and connecting members between said plate and said gages, whereby the adjustments of said plunger are controlled.
13. In a type-justifier, in combination, a series of gages arranged adjacent to each other and external to the line to be justified, means adapted to engage as many of said gages as there are intervals in a line, a space-plunger, and connecting members between the same and said engaging means, whereby a movement is imparted to said plunger in proportion to the number of gages engaged, for the purpose set forth.
14. In a type-justifier, in combination, a series of longitudinally-movable gages, a space-magazine, a space-plunger, a stepped plate adapted to intercept the movement of said plunger relatively to the magazine, and connecting members between said plate and said gages, whereby said movement of the plunger is controlled, for the purpose set forth.
15. In a type-justifier, in combination, a series of tapered gages, a series of oppositely-tapered blocks, means for engaging and advancing a group of gages, a space-plunger, connecting members between the plunger and said engaging means, a stepped plate adapted to intercept the lateral movement of said plunger, and connecting members between said plate and said gages, whereby the adjustments of said plunger are controlled, for the purpose set forth.
16. In a type-justifier, in combination with a magazine, a space-plunger adapted to be adjusted in accordance with the whole number of spaces required, and a secondary space-plunger arranged to engage fewer spaces than said whole number and of a different size from those located by said first-mentioned plunger, for the purpose set forth.
17. In a type-justifier, in combination, a space-plunger, means for adjusting the same in an approximately vertical direction in accordance with the whole number of spaces required, a secondary space-plunger, and means for adjusting the same in an approximately vertical direction to engage less than said whole number of spaces, for the purpose set forth.
18. In a type-justifier, in combination, a space-plunger, means for approximately vertical and horizontal adjustment of the same, in accordance with the whole number of one size of spaces required, a secondary space-plunger dependent upon said first-mentioned plunger for its lateral adjustment, and means for adjusting said secondary plunger in an approximately vertical direction to engage less than the whole number of spaces of a different size from those first indicated, for the purpose set forth.
19. In a type-justifier, in combination, a space-plunger adjustable in accordance with the whole number of spaces required, a remainder measuring device, a secondary space-plunger dependent upon the former plunger for lateral adjustment, and a space-lifting device adjustable with said secondary plunger, in an approximately vertical direction by said remainder device, for the purpose set forth.
20. In a type-justifier, in combination, a space-plunger adjustable in accordance with the whole number of spaces required, a remainder measuring device, a secondary space-plunger dependent upon the former plunger for lateral adjustment, a space-lifting device adjustable with said secondary plunger in an approximately vertical direction by said remainder device, and a gage-block connected with the remainder device and adapted to engage and move a type-line, for the purpose set forth.
21. In a type-justifier, in combination, a plurality of space-channels, two space-plunger blades, and a transversely-movable arm adapted to adjust said blades in operative relation with any two of said channels which are adjacent to each other, for the purpose set forth.
22. In a type-justifier, in combination, a plurality of space-channels, two space-plunger blades, two intermediate space-receiving channels in front of said first-mentioned channels, and a transversely-movable arm adapted to carry said blades and said space-receiving channels into operative relation with any two of said space-channels which are adjacent to each other, for the purpose set forth.
23. In a type-justifier, in combination, a plurality of space-channels, two space-plunger blades, two intermediate space-receiving channels, a transversely-movable arm adapted to carry said blades and said space-receiving channels into operative relation with any two of said space-channels which are adjacent to each other, and an ejector for removing spaces from said intermediate channels, for the purpose set forth.
24. In a type-justifier, in combination, a

plurality of space-channels having their bottoms on a common plane, a space-plunger adjustable in accordance with the whole number of spaces required, a remainder device, and a space-lifting bottom controlled by said device and adapted to raise a pile of spaces in one of said channels adjacent to said plunger, for the purpose set forth.

25. In a type-justifier, in combination, a series of gages, an engaging plate adapted to engage as many of said gages as there are intervals in the type-line, a guide connected by intervening mechanism with said plate, and a space-plunger resting upon said guide, whereby an approximately vertical movement is imparted by said plate to said guide and plunger, commensurate with the number of said intervals, for the purpose set forth.

26. In a type-justifier, in combination, an engaging plate adapted to travel a certain distance for each space required in a type-line, a guide connected by intervening mechanism with said plate, and a space-plunger resting upon said guide, whereby an approximately vertical movement is imparted to said guide and plunger, commensurate with the number of spaces in the line under justification, for the purpose set forth.

27. In a justifying mechanism, the combination of a space-magazine adapted to contain a limited number of sizes of spaces, space-ejecting mechanism, and means controlled by the shortage of a line and the number of word-spaces for locating said space-ejecting mechanism in position to eject the number of spaces of two sizes required to justify the line.

28. In a justifying mechanism, a justifying device representing by its gaging capacity at fixed points along the device the successive sizes of spaces, means for multiplying its gaging capacity by the number of spaces required, means for determining the shortage of an unjustified line by a measurement position along the justifying device, and means for causing the said measurement position to determine the spaces required to justify the line.

29. In a justifying mechanism, a justifying device including a series of gages, each representing by its gaging capacity at fixed points along the gage the successive sizes of spaces, means for selecting certain of said gages equal in number to the intervals in the line under justification, means for determining the shortage of an unjustified line by a

measurement position along the gages, and means for causing the said measurement position to determine the spaces required to justify the line.

30. In a justifying mechanism, a justifying device representing by its gaging capacity at fixed points along the device the successive sizes of spaces, means for multiplying its gaging capacity by the number of spaces required, means for determining the shortage of an unjustified line by a measurement position along the justifying device, means for dividing the distance between the fixed points by the number of spaces, and means for causing the said measurement position and division to determine the number of spaces of two sizes required to justify the line.

31. In a justifying mechanism, a justifying device including a series of gages, each representing by its gaging capacity at fixed points along the gage the successive sizes of spaces, means for selecting certain of said gages equal in number to the intervals in the line under justification, means for determining the shortage of an unjustified line by a measurement position along the gages, means for dividing the distance between the fixed points by the number of spaces, and means for causing the said measurement position and division to determine the number of spaces of two sizes required to justify the line.

32. In a justifying mechanism, in combination, a series of gages arranged adjacent to each other and external to the line to be justified, means adapted to engage as many of said gages as there are intervals in a line, a space-determining member, and connections between the space-determining member and said engaging means, whereby a movement is imparted to said space-determining member in proportion to the number of gages engaged.

33. In a justifying mechanism, in combination, a series of longitudinally-movable gages, a space-determining device, a stepped plate adapted to intercept the movement of said space-determining device, and connections between said plate and said gages for controlling the position of the plate by the gages.

BENJ. M. DES JARDINS.

Witnesses:

ISAAC A. ALLEN, Jr.,
CARL J. DIETRICH.