

F. A. JOHNSON.  
TYPE PACKING MECHANISM.

APPLICATION FILED MAY 6, 1904.

2 SHEETS—SHEET 1.

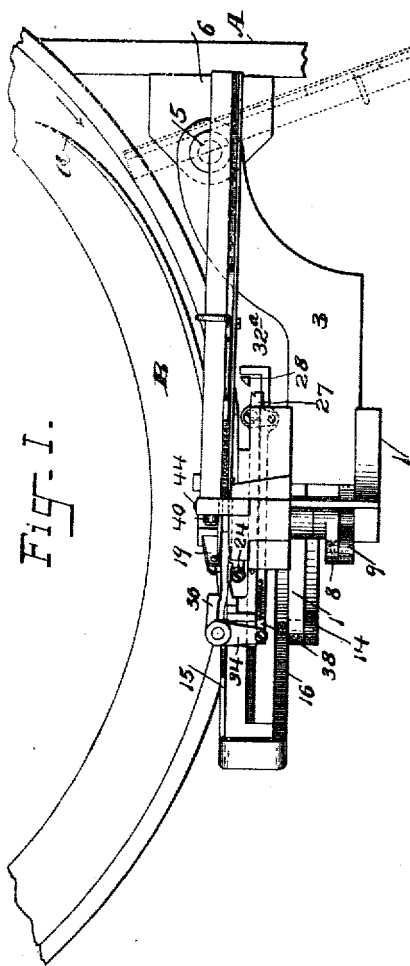

Fig. II.

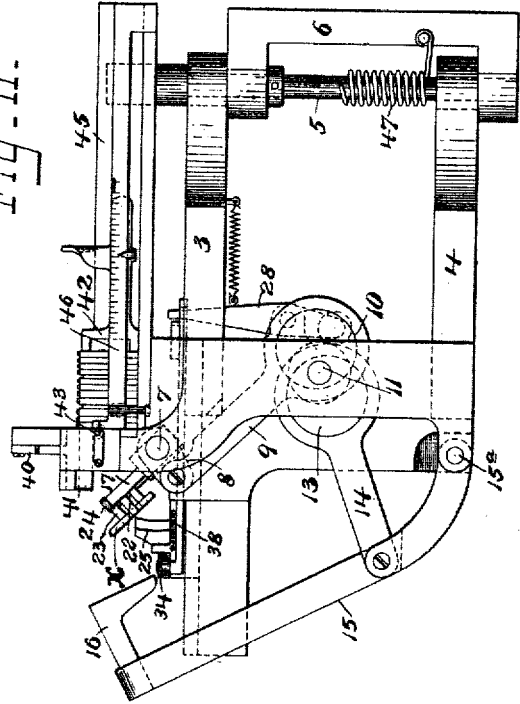
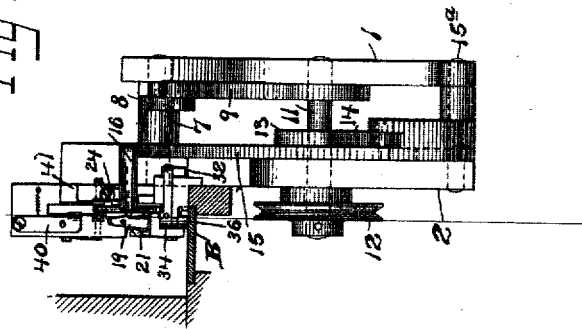

Fig. III.



Witnesses.  
*Chas. H. Botts*  
*U. Galiani*

Inventor.  
*Frank Allen Johnson*  
 By *Phil. H. Turner, Rice & Kennedy*  
 Attorneys

F. A. JOHNSON.  
TYPE PACKING MECHANISM.  
APPLICATION FILED MAY 6, 1904.

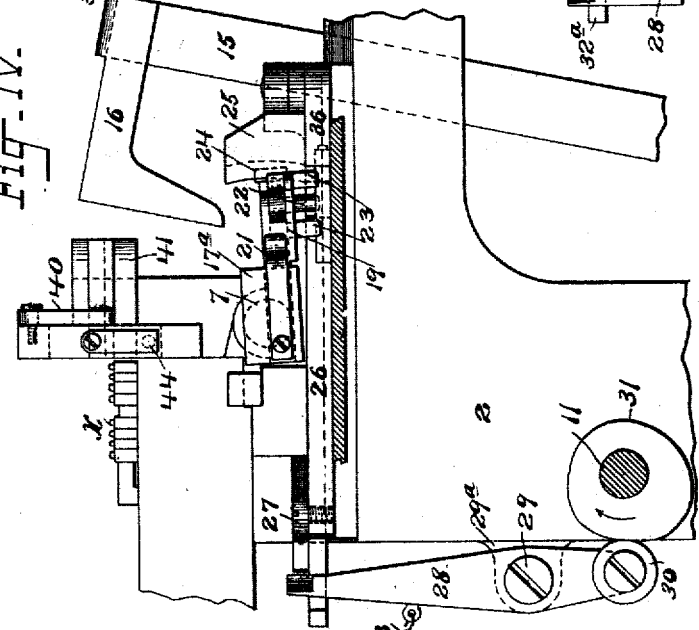
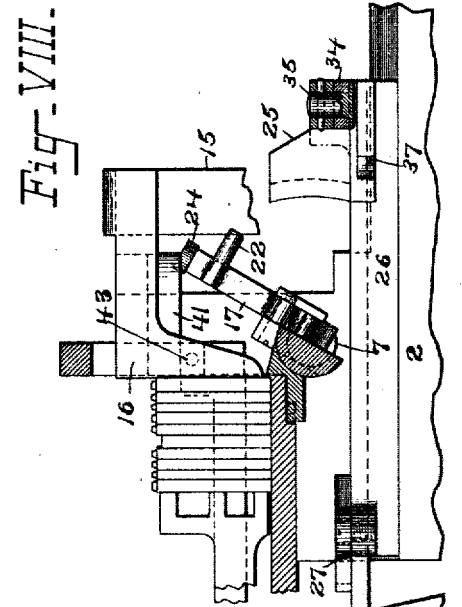
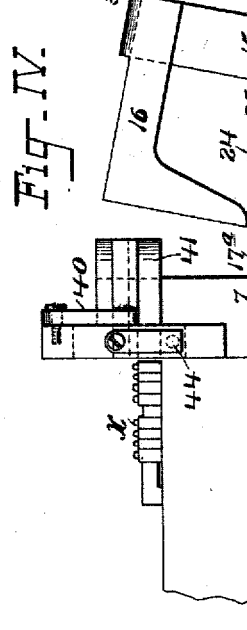
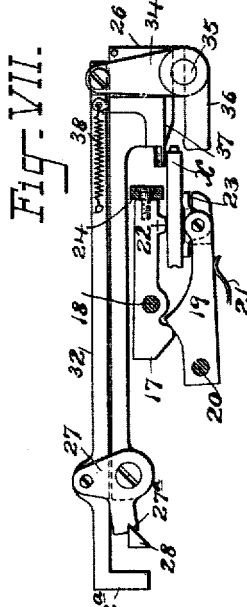
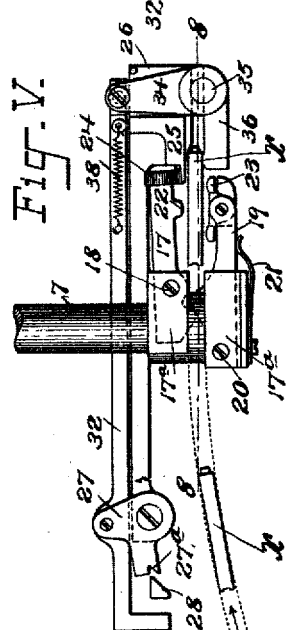
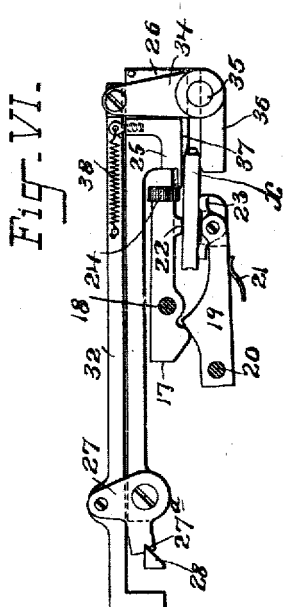

Witnesses.  
*Geo. H. Botto*  
*Algaliani*

Inventor.  
*Frank Lewis Johnson*  
 By *Phil & Lawrence H. Kennedy*  
 Attorneys

# UNITED STATES PATENT OFFICE.

FRANK AMOS JOHNSON, OF NEW YORK, N. Y., ASSIGNOR TO THE UNITYTYPE COMPANY, OF MANCHESTER, CONNECTICUT, A CORPORATION OF NEW JERSEY.

## TYPE-PACKING MECHANISM.

No. 814,048.

Specification of Letters Patent.

Patented March 6, 1906.

Application filed May 6, 1904. Serial No. 208,630.

*To all whom it may concern:*

Be it known that I, FRANK AMOS JOHNSON, a citizen of the United States, residing at New York, county of New York, and State of New York, have invented certain new and useful Improvements in Type-Packing Mechanism, fully described and represented in the following specification and the accompanying drawings, forming a part of the same.

This invention relates to an improved packer for type-setting and similar machines in which type are fed singly, the especial object of the invention being to provide an efficient mechanism for picking up type fed horizontally on their sides and placing them on their feet in a suitable receiving-channel or composing-stick.

The main features of the packer in its preferred form consist of a pair of gripping-fingers normally pressed into gripping position and opened as they are brought into position to seize the type, which fingers are oscillated to pick the type up from the carrier and raise them into a vertical position, a reciprocating striker which forces the type out of the grippers into the receiving-channel or composing-stick, and a feeler or trigger device for rendering the gripping-fingers operative when a type is in position to be picked up.

The invention includes also various other features of construction and combinations of parts, all as fully described hereinafter, and pointed out in the claims.

For a full understanding of the invention a detailed description of mechanism embodying the same in its preferred form will now be given in connection with the accompanying drawings, in which—

Figure 1 is a plan view of the packer as applied to a type-setting machine of a well-known type. Fig. 2 is a front elevation. Fig. 3 is an end elevation looking toward the right in Figs. 1 and 2. Fig. 4 is a rear elevation of a part of the mechanism on a larger scale. Fig. 5 is a plan view of the gripping mechanism shown in Fig. 4. Figs. 6 and 7 are details in plan. Fig. 8 is a sectional elevation on the line 8 of Fig. 5.

Referring to the drawings, A indicates part of the main frame of a type-setting machine to which the packing mechanism and its support is attached, which machine may be the well-known Thorne or Simplex machine.

Any suitable means may be employed for mounting the packing mechanism. Preferably, however, and as shown there are provided front and rear plates 1 and 2, which carry the gripper and operating mechanism and which are supported on the frame and spaced apart in any suitable manner, as by arms 3 and 4, mounted to swing on shaft 5 in a bracket 6 on main frame A, so that the packing mechanism may be swung outward away from the type-setting machine when desired. A portion of the type-carrier or rotating table or belt of the type-setting machine and the relation of the packer thereto are shown in Figs. 1 and 3, the type coming around on the carrier B in the direction of the arrow in Fig. 1 and being directed to the packer by the guide *a*.

The gripper is oscillated from a horizontal to a vertical position by a rock-shaft 7, suitably mounted in the plates 1 and 2 and actuated through an arm 8 and eccentric-rod 9 by an eccentric 10, mounted on shaft 11 and driven by pulley 12. That part of the rock-shaft 7 which projects inside the plate 2 is enlarged and slotted to receive plates 17<sup>a</sup>, in which the gripper-arms are pivoted, the front gripping-arm 17 being pivoted at 18 and the rear arm 19 at 20. A spring 21, secured to the plate 17<sup>a</sup>, to which the arm 19 is pivoted, forces the arm 19 against the short end of the arm 17, thereby causing the outer or free ends of the arm 17 19 to constantly seek engagement. The arms are provided with gripping-fingers, the arm 17 having a rigid finger 22 and the arm 19 having pivoted gripping-fingers 23 on opposite sides of the finger 22.

The gripper-arms 17 and 19 being normally held in gripping contact, means are provided for separating the arms so that the fingers may receive a type and for releasing the arms for gripping the type. For this purpose there is provided a slide 26, which slide carries a tripper 25, which is a block having a wedge-surface adapted to engage a roll 24 at the outer end of the gripper-arm 17, so that the gripper-arms are opened against the action of the spring 21 as they approach a horizontal position. The slide 26 carries an inclined stop-piece 37, which projects into the type-path and stops the type in position to be taken by the gripper. The slide 26 has

at its opposite end a bell-crank or angle lever 27, one arm of which has a notch, as at 27<sup>a</sup>, which is engaged in a certain position by the end of the lever 28, which lever is pivoted at 29 on bracket 29<sup>a</sup> and vibrated continuously by cam 31 on shaft 11, acting on roll 30 on lever 28 and return-spring 33. The outer side of this notch is preferably inclined, as shown, for a purpose hereinafter described.

The other arm of the bell-crank or angle lever 27 is pivoted to a connecting-rod 32, which rod has at one end a hook 32<sup>a</sup>, adapted to be engaged by the end of the lever 28. The other end of the rod 32 is pivoted to an arm 34 on a short vertical shaft 35, carried by the slide 26. This shaft 35 carries at its lower end a feeler-arm 36, which by the action of the spring 38, connecting the rod 32 and slide 26, is forced toward the type-path and stop-piece 37.

In delivering the type from the grippers the grippers are preferably not caused to loosen their grip on the type, but positive means are employed for forcing the type-piece from the grippers, assuring the proper delivery of the type. For this purpose a vibrating striker-arm 15 is employed, pivoted at 15<sup>a</sup> to the frame-plate 2 of the machine, which carries at its outer end the striker 16, the striker-arm being operated by eccentric 13 on shaft 11 through eccentric-rod 14. The striker passes between the gripper-arms in their vertical position and forces the type out of the grippers into a receiving channel or stick between a spring friction-piece 40 and rigid piece 41, which extends up from the frame-plate 2, and the type pass and are held from return by spring-seated plungers 43 44, as usual in such constructions. As shown, the receiving-stick consists of a rigid frame-piece 45 and a spring front piece 46 and is provided with a friction-follower 42 and is pivoted by the shaft 5 and held in receiving position by a spring 47, against the tension of which it can be swung around into the position shown in dotted lines in Fig. 1 to a justifying or other mechanism.

The operation of the packer is as follows: Starting with the grippers in a vertical position, the bowl 30 of lever 28 is then on the low part of cam 31 and the lever is at the end of its movement in one direction—that is, to the right in Figs. 1 and 2 and the left in Figs. 4 to 8. As the cam 31 rotates the lever 28 is first given a portion of its total movement toward the bell-crank lever 27, but stops before it engages the notched end of the lever. The hook 32<sup>a</sup> on the connecting-rod 32 being released by this movement of the lever 28, the connecting-rod 32 is now free to move and the spring 38 draws the connecting-rod into the position shown in Fig 5, thus forcing the feeler 36 toward the path of the type, so as to engage the type  $x$  as the latter is fed against the incline of the stop-piece 37, and the in-

ward movement of the feeler 36 is thus stopped, thus stopping the connecting-rod 32 with the notched arm of the bell-crank 27 in position for the lever 28 on its further movement to engage the notch on its further movement. Meanwhile the gripper-arms have been moved down to a horizontal position and the arm 17 been moved to open the gripper-fingers by the engagement of the roll 24 with the wedge-piece 25, so that the gripper-fingers are in position to seize the type when the roll 24 is released from the wedge-piece. All the parts are now in the position shown in Figs. 4 and 5. Just as the gripper-fingers are approaching their horizontal position, as shown in Fig. 4, the lever 28 receives its further movement to the right in these figures, and thus by engagement with the notched end of bell-crank 27 moves the slide 26 to the right from the position shown in Figs. 4 and 5, carrying the wedge-piece 25 out of contact with the roll 24 and permitting the gripper-fingers to close on the type. This movement is so timed that the wedge-piece is carried out of contact with the roll 24 at the moment when the gripper-fingers reach their horizontal position on opposite sides of the type-path, and the type is thus gripped as soon as the gripper-fingers reach the proper position on opposite sides of the type. The edge of the lever 28 engaging the incline on the outer side of the notch 27<sup>a</sup> rocks the lever 27 slightly, and when the lever 28 reaches the bottom of the notch it insures the feeler 36 being in its outer position, thus relieving all pressure on the type as it is lifted by the grippers. All the parts are now in the position shown in Fig. 6. The lever 28 continuing its forward movement forces the slide 26 still farther to the right from the position shown in Fig. 6 and frees the type end from the feeler 36 and stop-piece 37, as shown in Fig. 7, and the gripper-arms then begin their upward movement, carrying the type with them. The cam 31 now releases the lever 28, which is drawn backward by the spring 33, and the lever engaging the hook 32<sup>a</sup> on rod 32 carries the rod and slide 26 backward to their normal positions, and the wedge-piece 37 is thus brought again into the path of the roll 24, all the parts being thus brought into the position shown in Figs. 1 and 2, which show the gripper in its upward movement carrying the type. When the gripper carrying the type is in its vertical position, the striker-arm 15 moves toward the receiving channel or stick, and the striker 16 forces the type out of the grippers into the receiving-channel, the gripper then returning to the type-path. Fig. 8 shows these parts in the position they occupy after the striker has forced the type from the gripper into the receiving-channel or stick past the spring-plungers 43 44 and the gripper is moving back to the horizontal position to receive the next type. The oper-

ation is as above, assuming that a type has been fed into position between the stop 37 and the feeler 36. If no type is in position to be engaged by the feeler 36 as the latter is moved inward on the release of the hook 32<sup>a</sup> of rod 32, the feeler 36 moves inward sufficiently to draw the connecting-rod 32 into such a position that the notched end of the bell-crank 27 is thrown out of the path of the lever 28, so that the further movement of the lever 28 does not move the slide 26, and the lever 28 simply returns the connecting-rod 32 on its backward movement, this operation being repeated at each movement of the lever 28 unless a type is in position to be engaged by the feeler 36 on its inward movement.

The double finger 23, in connection with the single finger 22, prevents the type swinging in the fingers as they are raised, so that there is no danger of the type swinging in the gripper-fingers on their upward movement. It will be seen also that the two parts of this double finger 23 find their equilibrium on a type, so as to assure a firm hold, while permitting the end of the type to be moved slightly. Without this freedom of movement the mechanism would have to be made with great accuracy to enable the fingers to get a firm hold of the type while its front end is held between the wedge 37 and feeler 36.

It will be understood that the invention is not limited to the specific construction shown, but that many modifications may be made in the form and arrangement of the parts without departing from the invention defined by the claims. It will be understood also that the invention is not limited to mechanism in which type are changed from horizontal to vertical position, but the broader features of the invention may be embodied in type-packing mechanism of other classes.

What I claim is—

1. The combination with type-feeding means, of a gripper having gripping-fingers normally pressed into gripping position, means for separating said fingers and releasing them to receive and seize a type, and a striker for forcing the type from the grippers.

2. The combination with type-feeding means, of a gripper having gripping-fingers normally pressed into gripping position, a feeler engaging a type when in position to be seized, means for separating the fingers, and means controlled by the feeler for releasing the fingers to seize a type.

3. The combination with type-feeding means, of a gripper having gripping-fingers normally pressed into gripping position, a tripper for separating the fingers as the gripper approaches the type-path, and means for withdrawing the tripper to release the grippers when a type is in position to be seized by the fingers, and means for delivering the type from the grippers.

4. The combination with type-feeding

means, of an oscillating gripper having gripping-fingers normally pressed into gripping position, a tripper for separating the fingers as the gripper approaches the type-path, a feeler mounted to move across the type-path, and devices controlled by said feeler to withdraw the tripper and release the fingers when a type is engaged by the feeler.

5. The combination with type-feeding means, of an oscillating gripper having gripping-fingers normally pressed into gripping position, a tripper for separating the fingers as the gripper approaches the type-path, a feeler mounted to move across the type-path, devices controlled by said feeler to withdraw the tripper and release the fingers when a type is engaged by the feeler, and a reciprocating striker for forcing the type from the grippers.

6. The combination with type-feeding means, of an inclined stop-piece for the type, a feeler moving toward and from said stop-piece, a gripper having gripping-fingers normally pressed into gripping position, a tripper for separating the fingers to receive a type when in position between the stop-piece and feeler, and devices controlled by the feeler for withdrawing the tripper to release the fingers for gripping the type.

7. The combination with type-feeding means, of an inclined stop-piece for the type, a feeler moving toward and from said stop-piece, an oscillating gripper having gripping-fingers normally pressed into gripping position, a tripper for separating the fingers to receive a type when in position between the stop-piece and feeler, devices controlled by the feeler for withdrawing the tripper to release the fingers for gripping the type, and a striker for forcing the type from the grippers.

8. The combination with means for feeding type horizontally on their sides, of a gripper for picking up the type, means for oscillating said gripper to bring the type to a substantially vertical position, and means for delivering the type from the grippers.

9. The combination with means for feeding type horizontally on their sides, of a gripper for picking up the type, means for oscillating said gripper to bring the type to a substantially vertical position, and a striker for delivering the type from the gripper.

10. The combination with means for feeding type horizontally on their sides, of a gripper having gripping-fingers normally pressed into gripping position, means for oscillating said gripper from a substantially horizontal to a substantially vertical position, means for separating the fingers and releasing them to pick up the type when the gripper is in a horizontal position, and a reciprocating striker for forcing the type from the gripper when the latter is in a vertical position.

11. The combination with a type-carrier, of a gripper moving toward and from the car-

rier and having gripping-fingers normally held in gripping position, means for holding the fingers out of gripping position during a portion of the gripper movement toward the carrier and releasing the fingers to grip the type, and a striker for forcing the type from the fingers.

12. The combination with a type-carrier, of a gripper moving toward and from the carrier, gripping-fingers normally held in gripping position, a wedge-piece acting on one member of the gripper to hold the fingers out of gripping position during a portion of their movement toward the type-carrier, and means for withdrawing the wedge-piece to release the fingers to grip the type.

13. The combination with a type-carrier, of a gripper moving toward and from the carrier, gripping-fingers normally held in gripping position, a wedge-piece acting on one member of the gripper to hold the fingers out of gripping position during a portion of their movement toward the type-carrier, a feeler engaged by the type when in position for the gripper, and means controlled by the feeler for withdrawing the wedge-piece to release the fingers to grip the type.

14. The combination with oscillating spring-pressed gripper-arms 17, 19, and means for opening and releasing said arms to receive and grip a type, of reciprocating striker 16 for forcing the type out of said gripper, substantially as described.

15. The combination with oscillating spring-pressed gripper-arms 17, 19, and means for opening and releasing said arms to receive and grip a type, of reciprocating striker 16 for forcing the type out of said gripper, a stick into which the type is forced by the striker, and spring-stops for holding the type in the stick, substantially as described.

16. In mechanism for handling type, a type-gripper having the single finger 22 on one side and the pivoted finger 23 having

gripping-surfaces on opposite sides of the finger 22, substantially as described.

17. The combination with type-feeding means, of the inclined stop-piece 37 and feeler 36, spring-pressed gripper-arms 17, 19, gripper-finger 22 on one of said arms and pivoted gripper-finger 23 on the other arm having gripping-surfaces on opposite sides of the finger 22, substantially as described.

18. The combination with the spring-pressed gripper-arms 17, 19, of stop-piece 37, wedge-piece 25 acting on one of said arms during its movement toward the type to open the gripper to receive a type, and means for withdrawing the wedge-piece for releasing the grippers to seize the type.

19. The combination with the spring-pressed gripper-arms 17, 19, of stop-piece 37, wedge-piece 25 acting on one of said arms during its movement toward the type to open the gripper to receive a type, pivoted spring-pressed feeler 36 opposite stop 37, and means controlled by the feeler for withdrawing the wedge-piece when a type is between the stop and feeler, substantially as described.

20. The combination of the oscillating spring-pressed gripper-arms 17, 19, slide 26 carrying wedge-piece 25 for separating the arms, feeler 36 pivoted on the slide, connecting-rod 32 having a spring connection with slide 26, lever 27 connecting-rod 32 and slide 26, and oscillating lever 28 engaging lever 27 to move the slide when a type is in position for the gripper and acting to return the rod and slide to normal position, substantially as described.

In testimony whereof I have hereunto set my hand in the presence of two subscribing witnesses.

FRANK AMOS JOHNSON.

Witnesses:

J. A. GRAVES,  
C. J. SAWYER.