

H. W. Day Sheet 1. & Sheets.

Universal Hand Type Mould.

N^o 5846

Patented Oct. 10. 1848.

Fig: 1.

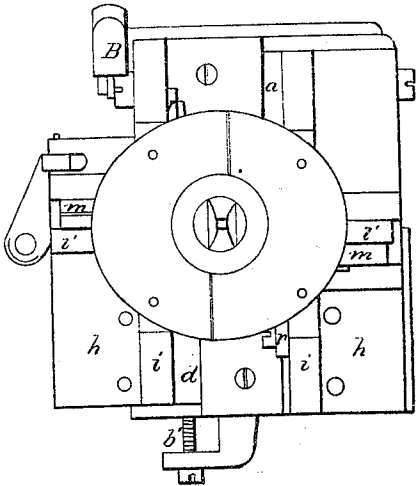

Fig: 2.

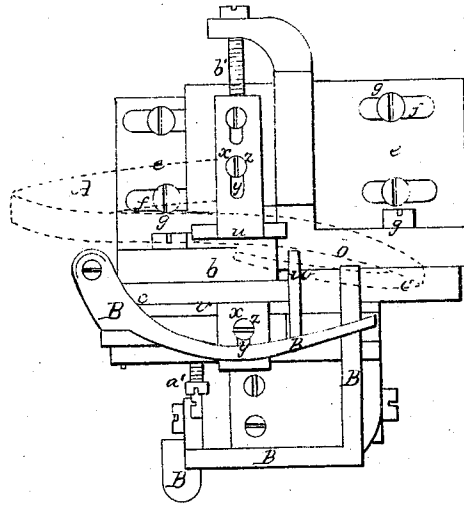

Fig: 3.

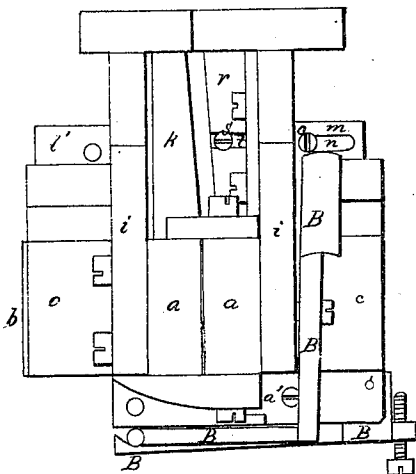
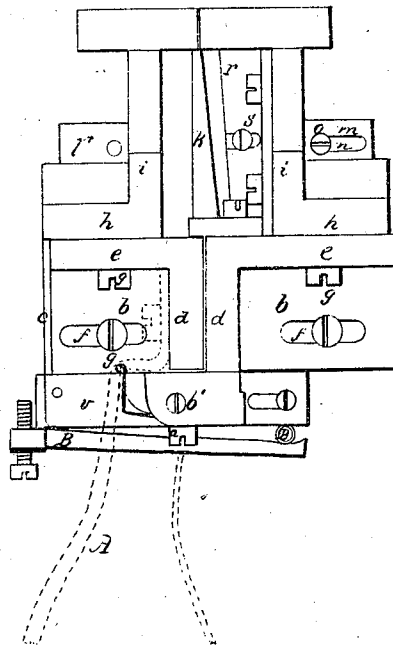

Fig: 4.



H. W. Day. Sheet 2. 2 Sheets.

Universal Hand Type Mould.

N^o 5846

Patented Oct. 10. 1848.

Fig: 5.

Fig: 6.

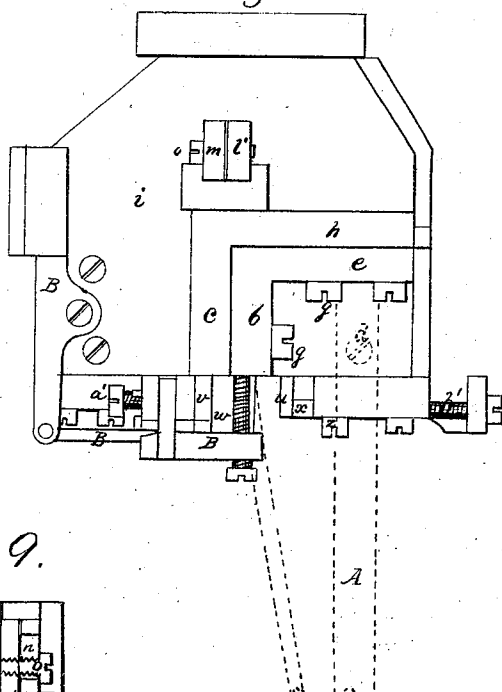
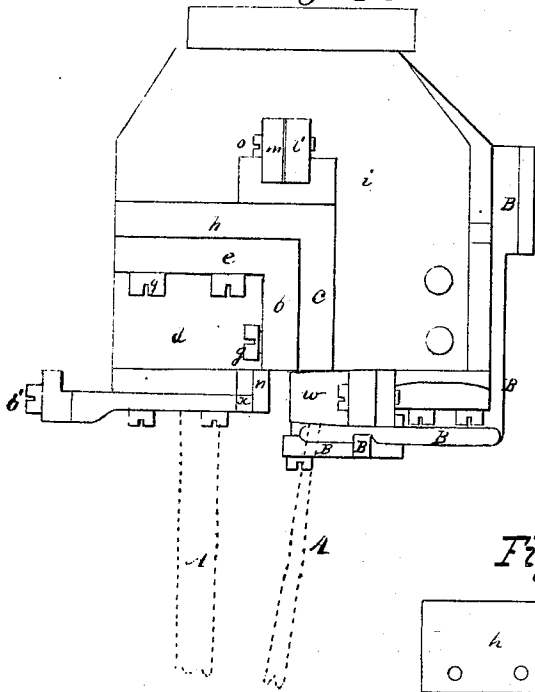

Fig: 9.

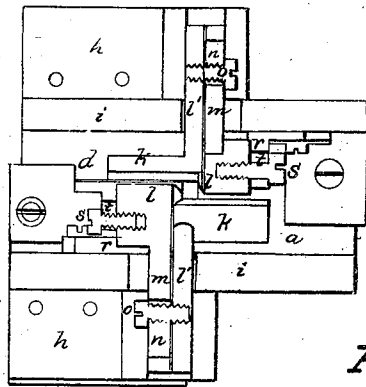

Fig: 7.

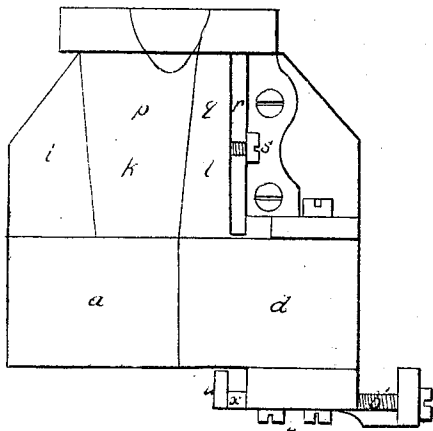
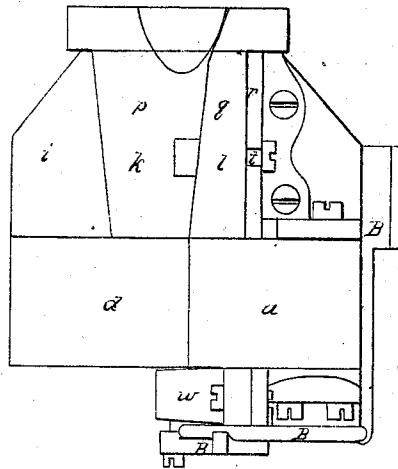

Fig: 8.



UNITED STATES PATENT OFFICE.

H. W. DAY, OF BOSTON, MASSACHUSETTS.

IMPROVEMENT IN TYPE-MOLDS.

Specification forming part of Letters Patent No. 5,846, dated October 10, 1848.

To all whom it may concern:

Be it known that I, HARTLEY W. DAY, of Boston, in the county of Suffolk and State of Massachusetts, have invented a new or Improved Mold for Casting Type, which I denominate the "Universal Hand Type-Mold;" and I do hereby declare that the same is fully described and represented in the following specification and accompanying drawings, letters, figures, and references thereof.

I term the said invention the "Universal Hand Type-Mold" because it is made up of movable and fixed parts, whose positions with respect to each other are capable of being so regulated as to adapt the mold to the casting of type of any desirable size, and with as much facility as by the common molds heretofore in use.

My mold can be readily adjusted with all the necessary accuracy and firmness to matrices originally fitted to any other mold. It has other advantages, both negative and positive, as follows: It does not require more strength to work it than the old mold. A boy with it may do all the casting of a large printing establishment. It is not liable to get out of order. The movable parts are held quite as strong, if not stronger, to the fixed ones than the parts held by screws in the old molds. When the mouth-pieces are fitted and screwed up for any particular size, a little hot metal may be cast in behind the face parts, which on cooling will render it impossible for them to alter their positions a fraction until the screws are started, when the metal will fall out.

It requires no more skill to alter and adjust this mold for various uses than it does to keep in order the old ones. In foundries one man has all the charge of the molds, alters, fixes, delivers, and receives them. A master printer would be perfectly competent to the care of these. It does not require any different practical knowledge to work it when fitted to any desired size, its operation being precisely the same as that of the old molds. Except by examination the same caster would not know that he was using a mold susceptible of endless changes. It is not affected so much by wear as are the old molds. The wear of the old molds on their sliding faces, in consequence of which the size of the type-body ma-

trix is gradually produced smaller and smaller, so that a font of type cast in it at one time will not perfectly justify with one cast in the same mold a year or two later, cannot affect this mold in the least degree. Finally, the cost of manufacturing molds made like this is not much more than that for constructing the old kind; but there are positive advantages of more or less importance, as follows: It will be serviceable to any printer, who, at a small expense besides that of the mold, can cast every variety of quads, high and low, and borders to any extent, enabling him to do with a little ingenuity many jobs which he could not accomplish without it.

One of these molds will do all the work which many old ones can do and much which they cannot do. So great is the accuracy required in type that among twenty old molds, embracing as many different sizes within a quarter of an inch, there might not be one found suited to a desired size. This we are informed by one of our best founders, who says "that although he has a great many molds he often has a job come in which he cannot do, because he has no mold exactly fitted in size." This mold can be adapted to a thousand sizes in a quarter of an inch, or any possible size.

A few—three or four—of these molds can do the work of all molds. They can cast more sizes than any number of the old ones. A small number of changeable ones will be better than an infinite number of unchangeable molds, even for practical use. They will cast as many sizes.

One of these molds may be kept any length of time on the same size—for an hour or for years. A letter-matrix belonging to any other mold can be perfectly fitted to this by the mere turn of a screw. Thus in a few moments hundreds of said matrices belonging to another mold can be adapted so as to cast the type in this mold.

In the establishing or replenishing of type foundries in using these molds the cost will be as nothing or mere nothing to thousands of dollars in the use of the old kind. A respectable foundry requires two hundred molds, which cost not less than five thousand dollars.

Six or ten of the universal hand type-molds, at an expense of from three hundred dollars to

five hundred dollars, would cast more sizes than a thousand old ones. They would be far better for practical use.

A printer sufficiently ingenious to cut a letter on steel could with one of these molds establish a type-foundry far from the regular source of obtaining types.

So great is the expense in establishing a foundry, type-molds being an important part, that in many instances it requires a company of individuals. With these molds a man having a comparatively small capital can establish himself as a type-founder. The invention must then have a tendency to diminish the price of type and multiply the means of knowledge. In this light as affecting the cause of literature and science the universal hand type-mold must be regarded as a very important and useful invention.

For every missionary station of importance this mold would be invaluable.

Of the drawings above mentioned, Figure 1 denotes a top view of my said improved mold, having its wooden sides or casings removed. Fig. 2 is a bottom or under side view of it. Fig. 3 is a rear end elevation of it. Fig. 4 is a front end elevation of it. Fig. 5 is an elevation of one side. Fig. 6 is an elevation of the opposite side. Fig. 7 is an elevation of one half or part, exhibiting its sliding face. Fig. 8 is an elevation of the other half, exhibiting its sliding face. Such other figures as may be necessary to clearly exhibit the various parts of the said mold will be hereinafter referred to and described.

The first part of my invention to be explained is that portion of the mold in which the body of the type is cast is made so as to be readily changed in size in order to adapt it to the casting of a type-body of any desired dimensions. For this purpose I make use in each half of the mold of a fixed or stationary plate, *a*, and a movable or adjustable plate, *b*, the said two plates being arranged at right angles to each other. One of them—viz., the plate *a*—has a plate, *c*, affixed to and extending back from it at right angles. The movable plate *b* is placed with its casting face in apposition with or in contact with the plate *c*, as seen in the drawings. It has a plate, *d*, extending from it at right angles, as seen in the drawings. The plate *d* has a plate, *e*, extended back from its upper edge and at right angles to its face, as seen in the drawings. Each of the plates *b* and *e* has several slots, *f f f*, made through it, through each of which a confining-screw, *g*, is made to pass into the fixed plate *c*, or another fixed plate, *h*, made to extend back from and at right angles to the main back plate, *i*, as seen in the drawings. The plates *a* and *c* are both fastened to the main back plate, *i*.

From the above it will be seen that the planes of the parallel sliding faces of the two plates *a* and *d* of each half part of the mold may be adjusted to any required distance apart,

so that when the sliding faces of the plates *a* and *d* of the one half of the mold are placed in contact with the sliding faces of the plates *a* and *d* of the other half part of the mold the face of the plate *d* of one half part of the mold will be at a distance from the face of the plate *a* of the other half part of the mold, which will correspond to the required or least width of the body of the type. The greatest width of the said body of the type being at right angles to its least width is determined by the distance between the casting-face of the plate *b* of the one half of the mold from the casting-face of the plate *c* of the other half thereof. In this respect my improved mold does not differ from others in use.

The next part of my improvement consists in the manner in which I make that part of the mold which forms the sprue of the type, or that part which is joined to the body in the operation of casting and is afterward broken therefrom.

The said manner of constructing the second part of my invention enables me not only to regulate the width of the sprue-matrix, but to adjust it so that its axis may be in a straight line with the axis of the matrix of the body of the type.

k l in each half of the mold are two dies or plates arranged so as to have their casting planes at right angles to one another, as seen in the drawings. They are disposed directly above the body-plates *a* and *d* and against the back plate, *i*. Fig. 9 exhibits a horizontal section taken through the confining-screws of the said two dies or plates and the back plate, *i*. In said figure it will be perceived that each of said plates has a rectangular shank or tenon, *l* or *m*, extending back from it at right angles and through the back fixed plate, *i*. A slot, *n*, is made through the shank *m*, and a clamping-screw, *o*, is made to pass through said slot and screw into the other tenon or shank. By means of said tenons and clamping contrivances affixed to the plates *k l* of each half of the mold, the two faces *p q* of the plates *k l* of each half part may be adjusted and fixed at their proper distance asunder in order to give any required width transversely to the matrix of the sprue. Now, in order that the plates *k l*, when so adjusted together, may be readily brought into such a position with respect to the plates *a d* as will bring the axis of the sprue-matrix in line with that of the matrix of the body of the type, I affix firmly to each of the back plates, *i i*, and at right angles to it, as seen in the drawings, a plate, *r*, against which the plate *l* is made to move. The said plate *r* has a slot, *t*, made through it, through which a clamping-screw, *s*, is made to pass and screw into the plate *l*. When the plates *l* and *k* are properly adjusted to the plates *a d*, as before described, they may be confined in their proper positions by screwing up the clamp-screw *s*.

The next part of my invention relates particularly to the mode of adapting the mold to

a letter-matrix bar of any ordinary width (made for any other mold) and the proper adjustment of the letter-matrix of said bar to the body-matrix of the mold. For this purpose I make use of two parallel movable gage-plates, *u v*, and a perpendicular movable stop-plate, *w*. Each of the said plates has a sliding shank, *x*, extending back from it at right angles to it, as seen in the drawings, and each shank *x* has one or more slots, *y*, and confining-screws *z*, by which its position may be adjusted and fixed. A forcing-screw, *a'*, is applied to the shank of the plate *v*, and another, *b'*, to the plate *u*, as seen in the drawings, for the purpose of forcing either or both of them transversely when necessary.

A is the spring which presses the letter-matrix bar up to its seat, as in other molds, and represented in dotted lines in Figs. 2, 4, 5, and 6. B B are the compound levers by which the letter-matrix bar is raised or moved off the type immediately after it is founded. They do not differ from those in use in other molds.

The letter-matrix bar is not represented in the drawings, as it is similar to those used in the common hand-molds, and is used in my improved mold in the same manner as in the old molds.

Having thus set forth my invention, what I claim is—

1. The above-described combination of movable and stationary plates constituting the body and sprue matrices as arranged and made to operate, together with adjusting contrivances, substantially in the manner and for the objects as specified.

2. In combination with the matrix of the body of the type, the movable gage-plates *u v* and stop-plate *w*, as arranged and made to operate, substantially as above set forth.

In testimony whereof I have hereto set my signature this 30th day of October, A. D. 1847.

H. W. DAY.

Witnesses:

R. H. EDDY,
JOHN LISCOM.