

# SHOP TALK

VOLUME 6 NO. 1

ATTENTION LINOTYPE MACHINIST

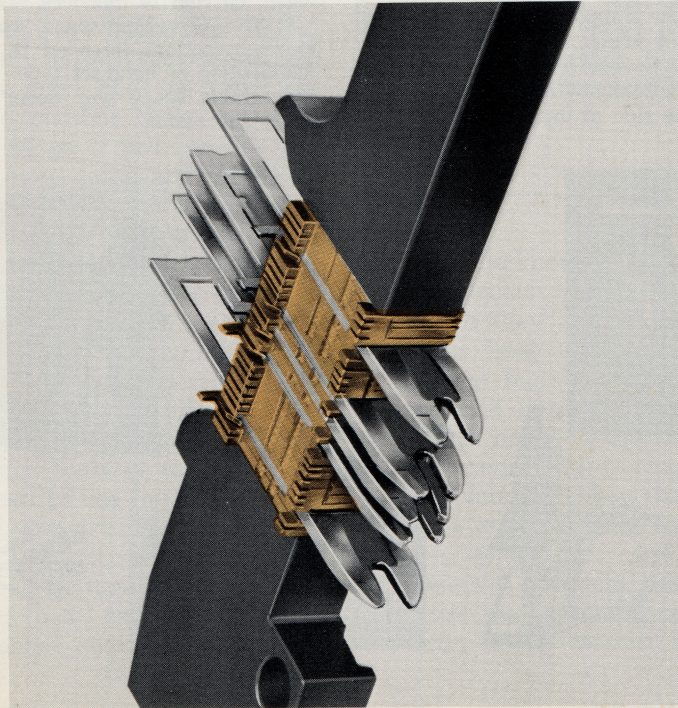

Linecasting  
**STAR ★ PARTS**  
Automation

**STAR PARTS CO.** SOUTH HACKENSACK, NEW JERSEY  
A DIVISION OF **POWERS & EATON Industries, Inc.**

POSTMASTER — FORM 3547 REQUESTED.

# SHOP TALK

Address all Communications to:

Alfred Archer, Editor  
2 South Main Street  
South Hackensack, N. J.

ANY MATERIAL IN THIS PUBLICATION MAY BE REPRINTED, WITH THE PUBLISHERS PERMISSION.

Text of this issue of SHOP TALK set in 9 and 10 point Star News.

## HISTORICAL COMMENTS PART 2

The old-time machines, shown on the back cover of volume 5 no. 2 of Shop Talk, stirred a considerable amount of interest amongst our readers. The prize winner in our identification contest was Vernon Eck, head of the printing department at Dunwoody Institute in Minneapolis, Minn.

The machines illustrated in the previous issue are:

A. The Dougall Linotype was invented and successfully operated in Canada around 1903. This machine had an assembling elevator which pivoted 90 degrees to reach casting position, but in many other aspects resembled the Linotype of that day.

B. This is the Simplex model of the Thorne machine which assembled hand-set type from a keyboard and distributed the type automatically by means of small rollers cut in the side of the type. It was

patented in 1880 and was used commercially for a number of years.

C. This machine was invented by Young and Delcambre in 1840. In a test run this machine set the equivalent of 170 single column lines per hour for more than a week. However, after the type was assembled, two men were required for line justification, making this a three-man operation.

D. This is a Model 16 Linotype, first manufactured in 1916. It was a two magazine mixer and less than 100 of these were manufactured.

E. The Model 15, of which nearly 1000 were produced, was a single, short-magazine machine, each channel of which carried 14 matrices.

F. The Cox Multispace was one of many inventions intended to speed up justification of hand-set type. This kind of variable space was never commercially successful.

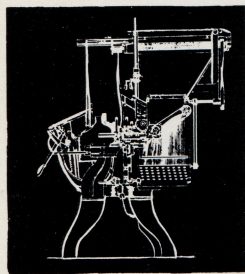

A

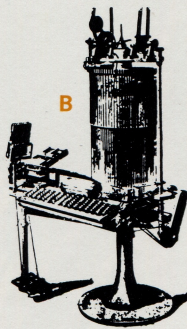

B

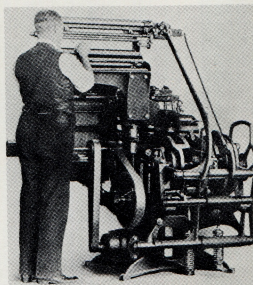

E

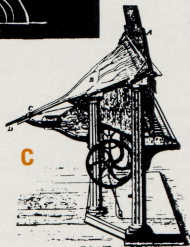

C

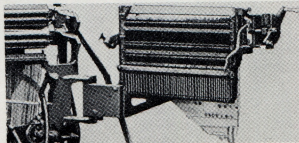

D

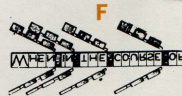

F

# THE HAIRLINE PROBLEM

By Marshall A. Joachim

(formerly Supervisor, Deluxe Check Printers, Inc., Clifton, New Jersey)

(Now retired)



thank him and Deluxe Check Printers, Inc. for their permission to share their knowledge with our readers.

*Hairlines in any composing room are a problem. In Deluxe Check Printers, where a perfect printing surface is mandatory, they can be disastrous. Marshall Joachim originally wrote this article solely for the guidance of Deluxe Check composing rooms across the country. We wish to*

Hairlines or lines appearing between letters of printed matter set on linecasting machines have been the subject of much discussion, many theories, and a great deal of curative effort, but they still continue to be a problem. In DeLuxe we have encountered hairlines, at times in epidemic proportions, and at other times we seem to keep this evil under fair control.

It is only natural for one who has spent a good deal of time and effort to combat these little unwanted wisps of print to ask how far we have come and where we are now in the battle.

Hairlines are nothing new. Since the linecasting machine was invented, they have been a major problem to some and no problem at all to others. I have had people in charge of large batteries of linecasting machines tell me they never had a hairline problem. They have fonts of matrices that have been in use for fifteen years or more and are still going strong setting straight news matter. I have seen newspapers with more hairlines than I care to remember. This disease strikes at some and

spares others. I wonder—can it be that some bring it on themselves and others take wise precautions against it? Is it that in later years some of the devices added to linecasting machines have been the cause of our present difficulties? Or, has the higher daily production from these machines anything to do with intensifying the hairline problem? Is the material from which matrices are made responsible because of variation in quality, structure, or hardness? What part do spacebands play in the problem? Are quadding and centering devices inherently responsible for causing hairlines? Can it be that quadders in improper adjustment are bad and properly set quadders are good? At some time or other, theories have been advanced blaming hairlines on most everything.

## WHAT DO WE KNOW ABOUT THE PROBLEM TODAY?

We do know that whenever hairlines occur the matrices between which they appear have the side walls bent inward so that when molten metal is pumped into the mold, it is possible for the metal to get between the matrices to a sufficient depth to reach the printing plane. We know that when hairlines are occurring on a machine, the spacebands and/or spacing material has metal adhering to the sides that abut the printing character of the matrix. We know we

find metal adhering to the vise jaw edges at the casting point.

### LET'S DELVE A BIT INTO SOME OF THE THINGS WE HAVE BLAMED

**Matrix Material**—The brass from which matrices are made must have certain characteristics in order to take the punching properly. It must be neither too hard nor too soft. I have had all matrix manufacturers tell me that the proper quality of brass was of much more importance to themselves as manufacturers than to the printer. We have found that Rockwell tests gave us a variety of degrees of hardness which may or may not be within the limitations set up by the manufacturers. We do not know what degree of hardness is correct and we do not know how much deviation is permissible. But I have yet to see a matrix that had been compressed, peened or otherwise distorted because it was too soft for the use for which it was designed.

**Higher Daily Production**—Very likely increased output has a good deal to do with the problem. Maintenance should possibly be tied to volume produced, and increased output may require increased maintenance and preventive measures.

**Spacebands**—This is a much kicked around item whenever hairlines are mentioned. We know that when we are having hairlines, we find metal on the sleeve side of the spaceband at the casting point and no metal on the opposite or wedge side. The absence of metal on the wedge side is easily, and I think,

correctly explained by the fact that the wedge is driven upward about  $\frac{3}{4}$ " while it is in tight contact with the matrices, and this wiping effect is an ideal cleaning device. As to the metal on the sleeve side, is it the cause of our trouble or does it result from our trouble?

Are quadders inherently the cause of hairlines? I have a fairly definite "No" to say to this. I have at times blamed the slap of the vise jaws against the sides of matrices. I have been convinced at times that quadders do not hold the line of matrices tightly enough to seal out the cracks. I have been convinced that one make of quadder was superior to another. At present, I am sure the conclusions were improperly arrived at in all cases. As an example, I cannot see how vise jaws can damage matrices by closing on them in anything like a normal manner. The jaw surfaces that close on the matrices are on one plane and the sides of the matrices are also flat planes where they contact the jaws. It is just not possible for the flat planes of the jaws to make an indentation in the middle of the flat plane of the matrix. Type metal or some other matter which might get between the jaw and the matrix could do it, but not the jaw itself.

Are quadders in improper adjustment responsible? A definite "Yes" to this, but only to the extent that such maladjusted quadders are responsible. I do not think this is the major cause, but I am certain that in one case, where a setscrew on a wedge lock came loose, it was the cause of a font of matrices being ruined. In this case, the adjustment was corrected and

a new font of matrices has been running close to four months with no sign of deterioration. Surely the linecasting machine is a wondrous accumulation of parts and it is a marvel that there are not a great deal more stoppages due to mechanical failure.

Does increased output mean we have to expect more hairlines? We have seen cases where three fonts of matrices on one machine were ruined by hairlines in a period of three weeks. We have seen a single font of matrices run four years on tape and the font does not have a single hairline in it today. If matrices had a fixed life, we could expect a deterioration after so many lines. In one case we have at least 3,000,000 lines cast from one font and, at most, an average of 15,000 lines from each of several others.

What part does maintenance play, and does maintenance have to increase with output? Maintenance plays a very important part in the breakdown of matrix side walls and the resultant hairlines. It is also certain that maintenance is required in proportion to the volume of output. What is maintenance? How do we practice preventive maintenance? What do we seek to prevent?

Spacing quads in place of spacebands and the use of quads on the ends of the lines—Using spacing quads instead of spacebands has been tried and, to my knowledge, has never proven to be the answer to the hairline problem. Hairlines occur at least as often, and very likely more often, because of the use of quads instead of spacebands. Quads on the ends of lines, the use

of a left hand quad for the left end, and the right hand quad for the right end of the line has proven to be no answer to the problem.

### LET'S AGAIN STATE WHAT WE KNOW

Whenever hairlines occur, the matrices between which they appear have their side walls bent inward. We know we find deposits or incrustations of metal on the outer side wall of the matrix. We find metal on the sleeve side of the spacebands at the casting point and none on the wedge side of the spacebands. We know we find metal on the vise jaw faces that grip the matrices during the cast.

Beyond a reasonable doubt, the type metal traces we find in the above places has something to do with the problem. How can it get to and adhere on these surfaces at these particularly crucial points? Without a doubt, it gets at these points during the casting of the slug. Let's examine the possibilities.

A line of matrices and spacebands, in casting position, is held rather tightly between the vise jaws and positioned in front of the mold. Molten metal is pumped into the mold from the rear. The line of matrices, being the front mold closure, is responsible for the molding of the slug beyond the mold body. The surface of the type is on one plane (the printing surface) and is, of course, the face of the printing character punched into the matrix. All of the other contours are molded by vise jaws, spacing material, and matrices.

A side view of a centered line of type looks like this:

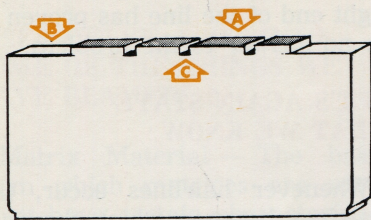

- A. Printing surface plane (punched character in matrix)
- B. Mold height plane (vise jaws)
- C. Mold height plane (spacing material)

It is well to note these planes carefully because it is in the area between the printing surface plane and the mold height plane that hairlines live. It is a fact that all lines cast from individual letter matrices have the basis for a sort of hairline. The fact that they are separate matrices means there must be a contour of the separation molded on the slug even from new matrices. This is below the printing plane.

There is a third plane much closer to the seat of our problem. This is the plane of the side walls of the matrices.

Let's look at the matrix construction.

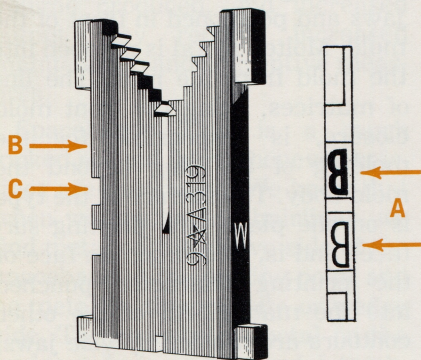

- A. Punched character of matrix (printing plane)
- B. Edge of matrix body (mold height plane)
- C. Side wall of punched character (between printing plane and mold height plane)

Examine a matrix and note how slight the difference is between the side wall and printing plane. The side wall is not always a straight line as in the above figure, but in the case of the letter "O" has a depression in the center. Other characters show the depression in various locations along the side wall area.

Let's now look at the spaceband and quad matrix.

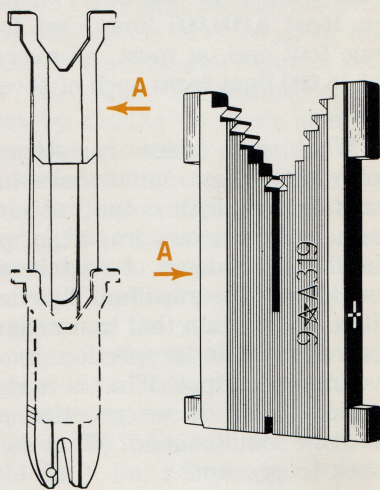

- A. Edge of spaceband and quad matrix (mold height plane)

In the spacebands and quads we have but one plane. But, and a very big but, we find that spacebands and quads appear in the contour of the cast slugs showing more than their edges. The sides of spacebands and quads are also

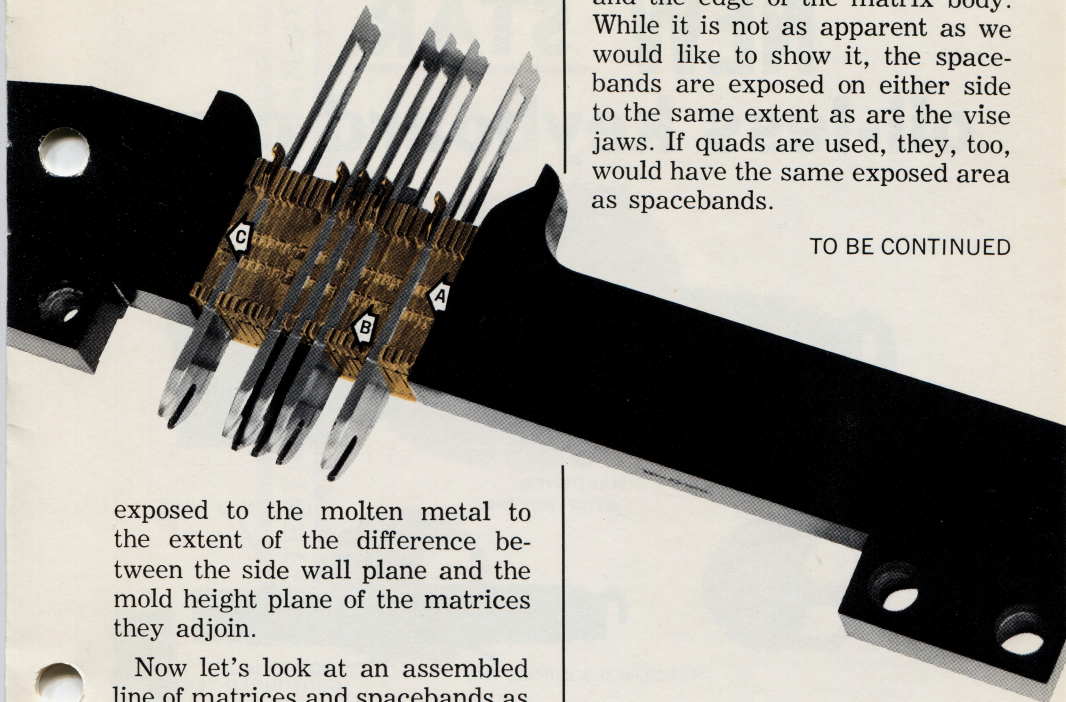

and the edge of the matrix body. While it is not as apparent as we would like to show it, the spacebands are exposed on either side to the same extent as are the vise jaws. If quads are used, they, too, would have the same exposed area as spacebands.

TO BE CONTINUED

exposed to the molten metal to the extent of the difference between the side wall plane and the mold height plane of the matrices they adjoin.

Now let's look at an assembled line of matrices and spacebands as it would be positioned before the mold during the actual casting of a slug.

- A. Punched character of matrix (printing plane)
- B. Edge of matrix body (mold height plane)
- C. Side wall of punched character

Note how the various planes mentioned before appear during the cast.

Note particularly point C. The vise jaws which squeeze the line of matrices and complete the closure of the front of the mold are flush with the mold body B. It will be readily seen that the faces of the vise jaws that contact the matrices are exposed to the molten metal to the extent of the difference between the side wall plane

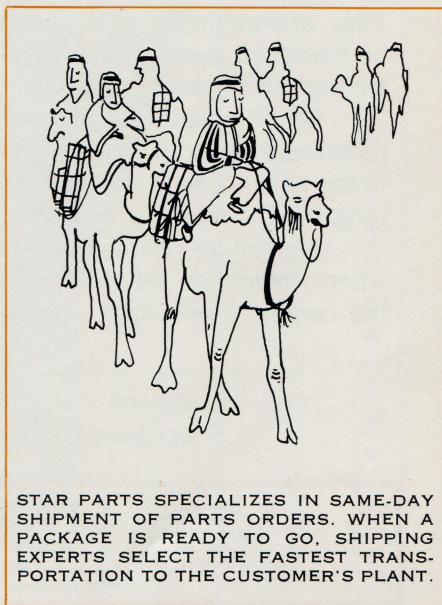

STAR PARTS SPECIALIZES IN SAME-DAY SHIPMENT OF PARTS ORDERS. WHEN A PACKAGE IS READY TO GO, SHIPPING EXPERTS SELECT THE FASTEST TRANSPORTATION TO THE CUSTOMER'S PLANT.

# NEW STAR oil-less keyboard cams

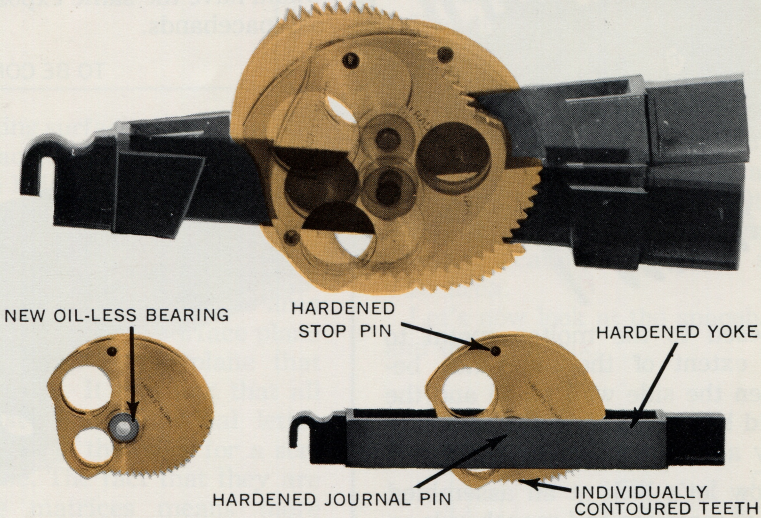

The new Star oil-less keyboard cams never require lubrication. They are equipped with engineered plastic bearings, which revolve on hardened journal pins. These special bushings practically eliminate friction and reduce maintenance to near zero.

Other advantages of the improved Star cam include individually contoured teeth which grip the rubber roll to give fast, positive lift to the key rod. Both the cam stop pin and yoke are hardened, providing long trouble-free life.

Star oil-less cams are reasonably priced and you save about 5% when a complete set of 91 cams is ordered. Part numbers below cover the complete new cam and yoke assembled. Order yours today.

	LINOTYPE	INTERTYPE
Keyboard	H-913-C	T-3755-C
Spaceband	H-1000-C	T-3756-C



**STAR PARTS Co.**  
SOUTH HACKENSACK, NEW JERSEY

A DIVISION OF **POWERS & EATON Industries, Inc.**  
CHICAGO • DENVER • KANSAS CITY, MO. • LOS ANGELES • MINNEAPOLIS • MONTREAL