

VOLUME 1

NUMBER 3

# SHOP TALK

Published bi-monthly by Star Parts, Inc., South Hackensack, N. J. in the interest of those who maintain typesetting machines.

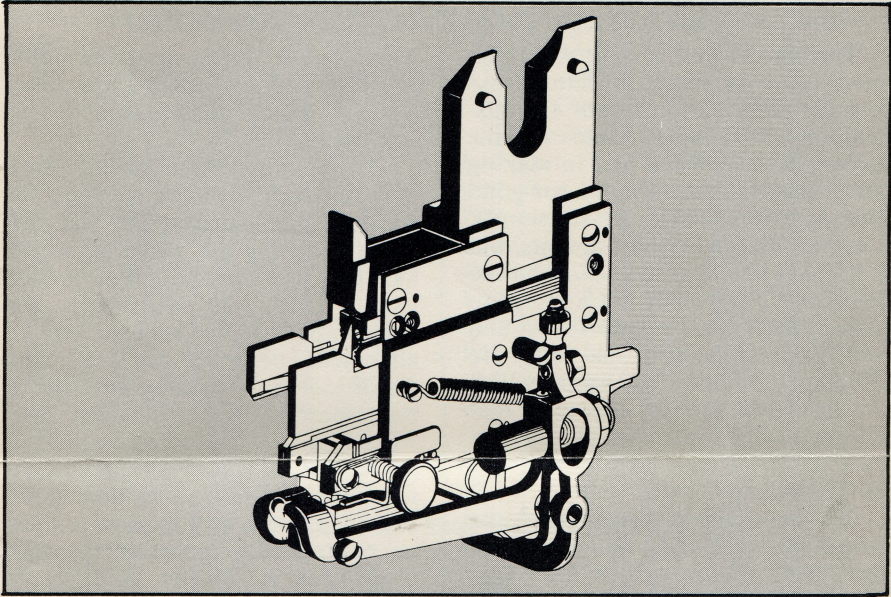

## A WORD FROM YOUR EDITOR

Every Star Parts order form carries a statement which guarantees our products to be free from defects in material and workmanship. We take that guarantee very seriously. When something goes wrong, we see that your complaint is processed within 24 hours, with rare exceptions.

We do our own manufacturing at Star Parts, and if you should send in a complaint on quality, it is discussed personally with the head of the Production Department. He immediately has the part checked and a report is made in a matter of hours to the Sales Department. Sim-

ilarly, other types of complaints are referred to the appropriate department head, within an hour or less of their arrival.

In practically every case, the necessary adjustment, replacement or explanation is on the way to you that same day.

Adjusting complaints immediately is just another part of Star service which helps you to keep your machines in production.

*Guido E. Herman*

GUIDO E. HERMAN

# SHOP TALK

QUIDO E. HERMAN, EDITOR  
Manager West Coast Agency, Star Parts, Inc.  
1620 W. Pico Blvd., Los Angeles 15, Calif.

Address all communications to:  
Mr. Emil Bendow, Star Parts, Inc.  
2 South Main Street, South Hackensack, N. J.

Any material in this publication may be reprinted, with the publisher's permission.

## DISTRIBUTOR BOX PROBLEMS Some points to check

During the past several weeks we have received numerous letters asking for information about the distributor box, and some of the experiences we have had in making these adjustments. One of our good friends wrote "it looks so simple, there are not many adjustments, but I guess I just don't know what to look for." We shall not attempt to cover distributor boxes fully, and will exclude mixers, as they are different and have problems which are peculiar only to the type machines on which they are used. However many of these suggestions can be applied to mixers.

We have found many machines which will not hold the setting of the "bite" of the matrix lift. This is because the distributor shifter enters the box too far and strikes the Font Distinguisher Block (Lino G-3193) or the Distributor Box Block (Int. V-230). These are used as the adjustment for the distance which the matrix lift engages the bottom of the matrix. This condition can usually be traced to a broken, bent or missing screw (G-126 or W-490). This screw is in the casting at the end of the grooves in which the shifter operates, limiting the distance the shifter can enter the distributor box.

The shifter should enter the box to a position where the spring pressure of the Distributor Shifter Slide Buffer is just sufficient to hold a thin matrix firmly against the distributor

box rails. In this position the shifter itself should not contact the block against which the matrix lift is positioned.

If the distributor shifter slide stop screw is bent or missing, the constant drive against the box will cause wear in the distributor box locating pins and the milled groove itself. This wear will cause the distributor box to become out of alignment between the rails and distributor bar, causing damage to both matrices and distributor bar. After checking the screws, loosen the distributor box bolt handle and inspect for any vertical motion of the box. If there is any motion, it must be removed by replacing the pins in the box (G-246 or W-233). In replacing these pins, it is necessary to dress them down so that the distance from the banking point of the distributor box against the beam to the slot in which the pins fit is very exact. The dimension for both Linotype and Intertype boxes is 1.313".

### DISTRIBUTOR BOX

A distributor box is a relatively simple mechanism. However it must be understood and correctly adjusted, or matrix damage will result. Of course the upper rails, front and back, must be of the same angle and dimensions, which can be determined by comparing the rails with those shown on pages 137 and 138 of the Star parts catalog. These are paired as follows: G-85 and G-489;

G-1479 and G-1480; G-2035 and G-2036, and G-3582 and G-3583. Page 138 shows the Intertype V-476 and V-477 as pairs. In checking these parts, compare the distance from the left end of the rail to the point where the angle descends. This is a determining factor and is as important as the other dimensions shown. The lower rails should also be replaced when new top rails are installed.

We can supply a new Distributor Box Rail Aligning Gauge (so new it's not shown in the catalog) which is used to assure even height or squareness of the upper rails, and also indicates if one rail has more wear than the other. Part No. Z-128, and it's not expensive.

#### DISTRIBUTOR BOX BARS

Many years ago Star Parts, Inc. realized the problems you fellows have in selecting the proper distributor Box bar. To take the guesswork out of this, Page 136 in the Star catalog shows nine different bars, all

drawn full size. Simply place your present bar over the drawing that matches your bar . . . you've got the right bar!

And you fellows with Comets. See that Comet bar G-4734-B with the short bar point? Get a pair of rails G-3582-A and G-3583-A and bar G-4734-B, and you'll be set up with the short bar point which is more rigid and will give less trouble. You don't run over 18-pt. on many Comets anyway!

#### LIFTING 2 THIN MATS?

The purpose of the distributor box bar point is to insure that only one mat at a time will be lifted to the box rails. All matrices have a bar point slot slightly under 2 points in thickness, at the bottom of the combination. This measure is the basis for the setting of the distributor box bar point in relation to the distributor box rails. If two mats lift at one time, it is evident this distance is over 2 points, in fact it would be double that amount. If a mat fails to lift at all, it is either because this

#### MAKEUP OF DISTRIBUTOR BOXES ASSEMBLED

| Dist. Box Part No. | Dist. Box Bar No.              | Dist. Box Rail, Front | Dist. Box Rail, Back | For Machine Models  |
|--------------------|--------------------------------|-----------------------|----------------------|---|
| (LINO TYPE)        |                                |                       |                      |   |
| G-3645-1           | G-2415                         | G-489                 | G-85                 | Lino—5—Slow Screws  |
| G-3645-2           | G-2415                         | G-2035                | G-2036               | Standard For Lino—5-8-31 Fast Screws (Mats up to 18 pt.)    |
| G-3645-3           | G-2415                         | G-1479                | G-1480               | Optional—if requested                                       |
| G-3645-4           | G-1434                         | G-2035                | G-2036               | Standard For Lino—8-14 Fast Screws (Large Mats 18 pt. & up) |
| G-3645-5           | G-1434                         | G-3582                | G-3583               | Optional—if requested                                       |
| G-3316             | G-3309                         | G-3582                | G-3583               | Late 8-14-31-32-33-34 with wide spaced Dist. Screws         |
| G-4838-1           | G-4734-B<br>(Short Bar Pt.)    | G-3582-B              | G-3583-B             | Comet (Standard)  |
| G-4838-2           | G-4734<br>(Long Bar Pt.)       | G-3582                | G-3583               | Comet (Optional)  |
| (INTERTYPE)        |                                |                       |                      |   |
| V-480              | V-491                          | V-477                 | V-476                | Standard for A-B-C-C4-D                                     |
| V-1435             | V-491                          | V-1436                | V-1438               | Standard for H—H4   |
| *V-307             | Substitute V-480 Box—See above |                       |                      |   |

\*This box discontinued. V-480 can only be used with the combination of bar and rails listed. Bars with short points cannot be used.

distance is less than 2 points so the mat cannot pass, the bar point is bent, or there is not sufficient bite or lift to the matrix lift itself.

In order to facilitate a more convenient method of replacing distributor box bar points, Star makes all its bars so the point can be replaced with the removal of one screw. There are no pins holding the bar point as on conventional bars. Because Star bars are designed with the machinist in mind, bar points are made slightly oversize in length, to compensate for wear which may be present on the old box rails. While this may, in some instances, require a light touch-up on the part of the machinist doing the installation, it does assure him material with which to work and a resulting good job can be accomplished.

#### THE MATRIX LIFT

Wear is the biggest problem in matrix lifts. Looseness of the pin and the hub, wear in the cam lever and lift lever, looseness in the mat lift cam roll and pin . . . all tend to make accurate adjustments impossible. Star levers are made with bearings which prolong their life, but proper attention and lubrication are vital to a trouble-free distributor box.

Many plants are running with just about any old spring in the matrix lift. (The one that holds the lift against the bottom of the matrix). Every time a mat goes into the box, the distributor screws pull the matrix

over the end of the lift, and if you hear anything but a very slight "click" the matrices are being held too tight by the matrix lift spring. This condition places wear on the lugs of the matrices, as well as the distributor screws. Use the proper springs; G-98 and W-100. The same type of damage can be caused by having the buffer spring too strong. Again, use the proper springs.

The lift should raise a matrix just high enough to clear the rails by  $1/32''$ , and it is well to check a wide mat while it is going through the box, to be sure there is no bind at any time until it is on the combination bar. Some machinists prefer to make the lift adjustment by pushing a matrix all the way through the box until it contacts the rails. Then, holding the matrix down with a screw driver on the lower lug, adjust the lift roller with the lift cam, which should be in its lowest position, so there is  $.010''$  of clearance at this point.

Of course the lift is adjusted so the actual "lifting" is done by the step in the matrix lift. Wear and misadjustment make it possible under some conditions, for the top of the lift to get under a matrix, with the result the lift timing is wrong, the mat is lifted into the distributor screws, and extensive matrix and screw damage will result. The proper setting of the lift adjustment, described in the previous paragraph, will prevent this type of damage.

## Linecasting machine parts...

### HOW THEY ARE MADE (CONCLUSION)

When all the milling operations are completed, most parts have to be finished off for two purposes: appearance and accuracy of dimension. This is the function of the grinder. It is in the grinding de-

partment that the part is given its final dimension down to the tenths of thousands if necessary. The tolerance of dimension is determined by the function of the part on the machine. This is where the part

receives its final straightening. Hundreds of different wheels are used in the process, each grinding wheel having a different grit or shape depending on the job it is assigned to do.

Of course there are other machine tools used in making linecasting machine parts. One of these, the drill press, is familiar to most of our readers, although in its simplest form. In a machine shop of this type, most of the drill presses are of the multiple spindle variety. These permit several holes of different sizes to be drilled into one piece without moving the part from this particular machine. Here too, ingenuity in the design of the tool, in this case called a jig fixture, can save operations. On this same drilling machine holes are tapped as drilled. These spindles are adjustable for speed and depth of thrust. A drill must be run at slow speed if the hole is large, and can be run at higher speeds as the hole becomes smaller. The spindle is set so that the drill when pulled down by the operator, can only go to set limits, in cases where holes do not go all the way through the part.

Screws are made on various sizes of turret lathes. The large bolt, of course, is made on the larger size of turret lathe, and the sizes go down

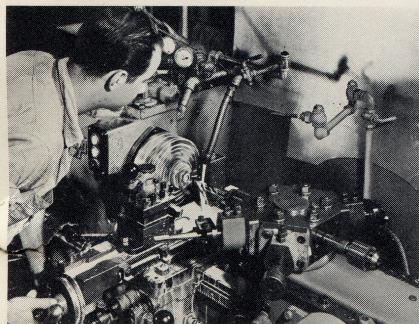

The versatile turret lathe is set up in advance for several consecutive operations.

to the automatic screw machine which is really a very small size turret lathe. There are of course many other machine tools like the circular grinders, used for the round shaped parts. The sanders, and the tumblers are used to remove burrs from some finished parts. Miscellaneous small machines, some specially designed, are used for certain special operations.

Finally, comes the bench work operations. This is where the assembling of parts is done as, for instance, in such cases as a complete delivery slide, or a first elevator jaw complete, etc.

Before the parts end up in the stock room, a very large percentage of them go through an oxidizing bath which gives it the smooth black finish which you see on many of the parts you get from the Star Parts factory. This is not a plating, but is a chemical cooking process, very closely controlled.

This gives you, we hope, a birds-eye view, sketchy as it may be, of the investment and skills involved in the making of parts before they reach your work bench. Perhaps the best way to appreciate the work involved, is to come to the Star Parts plant in person, and this you are cordially invited to do anytime you are in the vicinity.

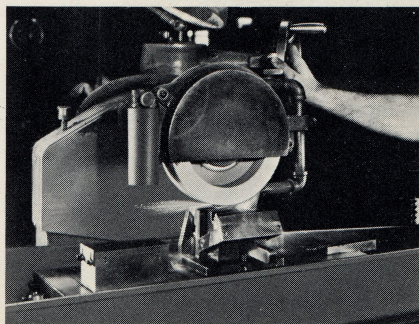

Extreme accuracy and very fine finish are provided by the grinding machine.

# GRANDPA SAYS...



"Ma put me to work the other day, seems she was havin' trouble with the front door stickin' shut," said Grandpa. "Got out my tools and got the door planed down on the bottom, but you can just bet yer boots, son, comes a dry spell like we had two years ago, and a cat will be able to walk under the door without touchin' a whisker."

Thought I'd have a little fun with Grandpa, so asked him why he didn't make the door adjustable, so he could make the door higher or lower to fit the frame.

"You know, I thought of that," snapped Grandpa. "And do you know what made me think of that idea?" "No, I don't" I assured him, waiting for him to come up with some of his usual wit.

"Seems I recall one time workin' on a machine where the long finger was wearin' a groove in the back of the assembling elevator. You know they'll do that if that brass block up there gets worn." "Yes," I said, "but what's that got to do with a door that sticks shut?"

Grandpa knew I was ribbing him by this time and he came right back . . . "Well, I remember we had to get a whole new block that holds the

long finger, because it was worn in the grooves. We ordered one from that Star Parts feller, and was it a dandy! Why they made it in two pieces, like you said, and it could be adjusted if it got worn, so's you could take up the wear. I think the Star people call it a "everlastin'" block or somethin', anyway it was still going strong last time I was over to the shop. Pretty clever riggin' I'd say."

Once Grandpa gets started, he sure gets wound up. "And besides that," he went on. "you don't even have to take the block out of that there slide to take up the wear. Just loosen the 2 screws, and they got a couple of little springs in there that spreads the pieces apart, you

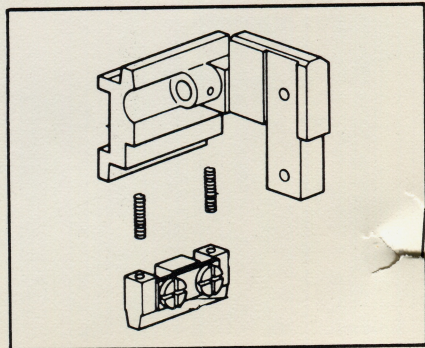

tighten it up and you're back in business. That's another one of them 'Improved' Star parts, ain't it?"

Grandpa sure is right . . . this is just another example of Improved Star parts that are interchangeable without alterations to machines. But

what Grandpa didn't know was that every one of the long finger blocks (and the short finger blocks, too) are checked for interior flaws and porous castings before going into stock. This is just another way Star makes sure of quality.

## THE MASTER MIND



The new machinist on his first job on a daily. He had a new tool box, with a key, new coveralls and of course with this background there was nothing he couldn't fix. His first call was on No. 4, the operator said the hyphens were doubling. SOOooo . . . gets the gas can, squirts the cam, squirts the weight, jiggles the hyphen a few times and says "Try that."



Star Sales Representatives practice "Soft Sell" to win the confidence and friendship of their customers!

Half hour later the light goes on No. 4 again. Hyphens still doubling! Goes thru the same thing again, says, "Try that."

Noon comes around and the operator calls him over. "Look, buddy, this is your first day, I don't want you to think I'm a crab, but really those hyphens are still doubling." Machinist says, "OK, I'll fix it and when you get back you won't have any more trouble."

About quitting time the machinist got brave, came around and said, "How's the hyphens?" Operator said: "You know I haven't had a double all afternoon—in fact now I have to hit it twice to get a hyphen, what's wrong?" The machinist really had him this time! He said "That's easy . . . you only got one hyphen in the magazine."

SEE GRAPHIC ARTS IN ACTION

7th EDUCATIONAL  
**Graphic Arts**  
EXPOSITION

NEW YORK COLISEUM - SEPT. 6-12, 1959

Be sure to visit us at booth No. 342

ATTENTION LINO TYPE MACHINIST

SOUTH HACKENSACK, N. J.  
**STAR PARTS, Inc.**



STAR PARTS, INC.  
Factory & Main Office  
South Hackensack, N. J.  
Tel: DIamond-3-4810

TWIN CITY LINO SERVICE  
2350 Highway 100  
Minneapolis 16, Minn.  
Tel: WEst-9-7807

STAR PARTS, INC.,  
Western Branch  
1327 Broadway  
Kansas City 5, Mo.  
Tel: HArrison-1-5522

HUNT-BROWN CO., INC.  
13 School Street  
South Acton, Mass.  
Tel: COLonial-3-7242

STAR PARTS, INC. AGENCY  
208 No. Wells Street  
Chicago 6, Illinois  
Tel: ANdover-3-3423

A. E. HEINSOHN  
1443 Blake Street  
Denver 2, Colorado  
Tel: TABor-5-8251

QUIDO E. HERMAN  
1620 W. Pico Blvd.  
Los Angeles 15, Calif.  
Tel: DUnkirk-4-2128

STAR PARTS (LINECASTING)  
CANADA LTD.  
322 Youville Square  
Montreal, Quebec  
Tel: DUpont 7-6221

