

## PATENT SPECIFICATION



Application Date: Nov. 11, 1940. No. 16331/40.

543,553

Complete Specification Left: Nov. 11, 1941.

Complete Specification Accepted: March 3, 1942.

## PROVISIONAL SPECIFICATION

## An Improved Punching Tool

We, JUNEERO LIMITED, of Stirling Corner, Boreham Wood, Hertfordshire, a British Company, and WILLIAM JAMES RAND, of the same address, a British Subject, do hereby declare the nature of this invention to be as follows:—

This invention relates to a punching tool which is chiefly intended for punching holes in sheet metal or metal strip employed in manufacture, constructional or repair work, but is also applicable for punching other sheet material, and has for its object to provide a very simple construction of tool comprising a punch proper and a combined holder, guide and apertured anvil or die, in which the punch is mounted.

According to this invention the punch consists of a hardened cylindrical steel rod reduced in diameter at the punching

end and the combined holder guide and anvil or die is formed of a steel bar bent at the middle to a U-shape and bored near the ends with coaxial holes of different diameters which form respectively a guide for the punch and an aperture or die through which the punchings are driven.

Owing to the reduction in diameter of the punch at the punching end a shoulder is formed which constitutes a stop for the punch as will be understood.

The punch is effectually supported and guided in the U-shaped holder by which the punch is held at a safe distance from the hand of the operator while at work.

Dated this 11th day of November, 1940.

WHEATLEY & MACKENZIE,  
Coolcower, Banstead Road,  
Banstead, Surrey,  
Agents.

## COMPLETE SPECIFICATION

## An Improved Punching Tool

We, JUNEERO LIMITED, of Stirling Corner, Boreham Wood, Hertfordshire, a British Company, and WILLIAM JAMES RAND, a British Subject, of Redcot, Park View, Hatch End, Pinner, Middlesex, formerly of Stirling Corner, Boreham Wood, Hertfordshire, do hereby declare the nature of this invention and in what manner the same is to be performed, to be particularly described and ascertained in and by the following statement:—

This invention relates to a punching tool which is chiefly intended for punching holes in sheet metal or metal strip employed in manufacture, constructional or repair work, but is also applicable for punching other sheet material, and has for its object to provide a very simple construction of tool comprising a punch proper and a combined holder, guide and apertured anvil or die, in which the punch is mounted. It is of the type consisting of a U-shaped punch holder and guide, and anvil which has at its open ends co-axial holes of different diameters for the reception of the punch.

According to this invention the punch

[Price 1/6 Price 4s 6d]

consists of a hardened cylindrical steel rod reduced in diameter at the punching end, and the combined holder guide and anvil or die is formed by bending a steel bar at the middle to a U-shape and bored near the ends with coaxial holes of different diameters which form respectively a guide for the punch and an aperture or die through which the punchings are driven.

The punch is effectively supported and guided in the U-shaped holder by which the punch is held at a safe distance from the hand of the operator while at work.

In the accompanying sheet of illustrative drawings:—

Fig. 1 is a perspective view of a punching tool constructed according to this invention and

Fig. 2 is a section taken along the line II—II Fig. 1.

Referring to the drawings the punch proper which consists of a hardened cylindrical steel rod *a* as aforesaid has a portion *b* of reduced diameter at the lower end. A U-shaped holder *c* consisting of a bent steel bar is formed at the end of

one arm with a guide aperture  $d$  for the  
 shank of the punch and at the end of the  
 other arm with a die aperture  $e$  in axial  
 alignment therewith, the two apertured  
 5 ends of the holder  $c$  being suitably  
 hardened.

Owing to the reduction in diameter of  
 the punch at the punching end a shoulder  
 $b^1$  is formed which constitutes a stop for  
 10 the punch as will be understood.

In some cases an elongated bush is fitted  
 in the guide aperture  $d$  for the punch,  
 for accurately guiding the punch and  
 maintaining the necessary rigidity be-  
 15 tween the punch and guide or holder  
 during the punching.

The punch may also be provided with  
 a head or handle for ease of withdrawal.

The portion of the holder between the  
 20 free ends and the bend is of sufficient  
 length to enable it to be easily grasped  
 by the hand of the operator in such  
 manner that there is no danger of hitting  
 the fingers when the punch is struck with  
 25 a hammer.

It will be seen that the work to be  
 punched can be held with the other hand  
 or be placed in position between the punch  
 and die and that the tool and work can  
 30 be manipulated very conveniently.

Having now particularly described and  
 ascertained the nature of our said inven-  
 tion and in what manner the same is to  
 be performed, we declare that what we  
 claim is:—

1. An improved punching tool of the  
 type referred to consisting of a punch  
 proper, and a combined anvil holder and  
 guide for use therewith, in which the  
 punch is supported and guided, wherein  
 the punch consists of a hardened cylin-  
 40 drical steel rod, reduced in diameter at  
 the punching end, and the combined  
 holder or guide and anvil or die consists  
 of a steel bar bent to a U-shape and bored  
 near the ends with coaxial holes of  
 different diameters for the purpose  
 described.

2. An improved punching tool accord-  
 guide bush for accurately guiding the  
 punch in the holder.

ing to claim 1 including an elongated  
 3. The improved punching tool substan-  
 tially as described with reference to the  
 accompanying drawing.

Dated this 11th day of November, 1941.

WHEATLEY & MACKENZIE,  
 "Coolewer", Banstead Road,  
 Banstead, Surrey,  
 Agents.

[This Drawing is a full-size reproduction of the Original.]

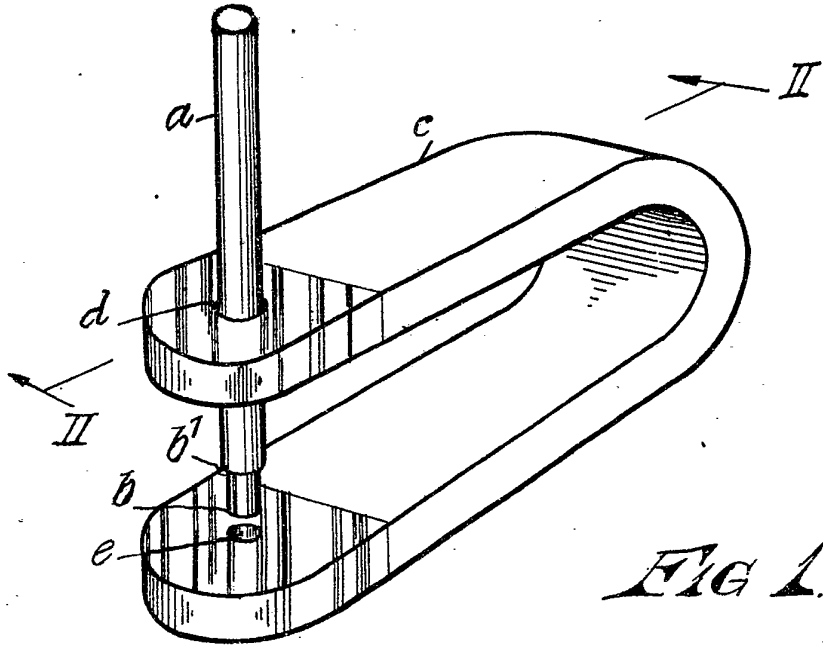

FIG. 1.

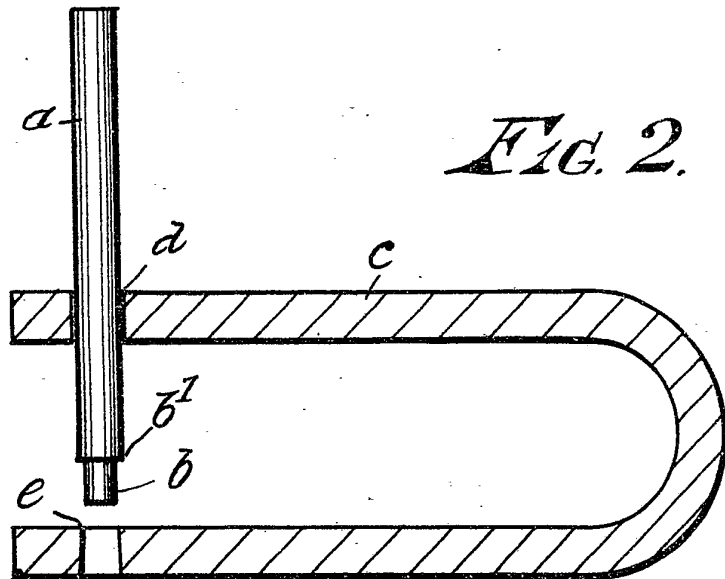

FIG. 2.